

Ultracom

Installation and Servicing

24cx

G.C. No. 47-019-06

30cx

G.C. No. 47-019-07

**High Efficiency
Condensing Combination
Boilers**

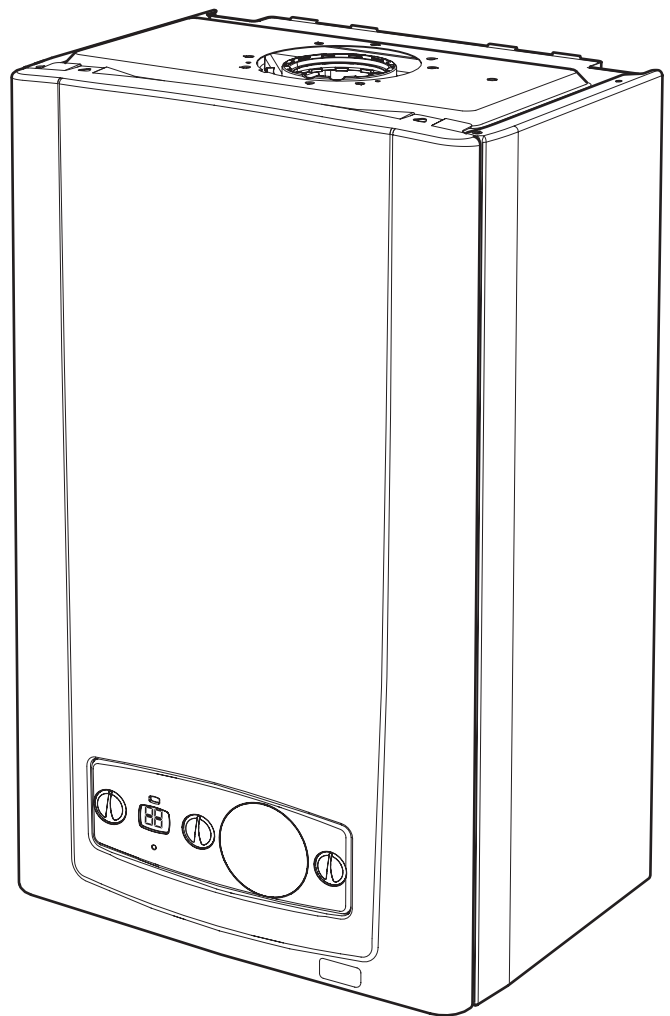

Guarantee Registration

Thank you for installing a new Glow-worm appliance in your home.

Glow-worm appliances are manufactured to the very highest standard so we are pleased to offer our customers a Comprehensive Guarantee.

This product is guaranteed for 24 months from the date of installation or 30 months from the date of manufacture, whichever is the shorter, for parts and labour.

The second year of the parts guarantee, from the beginning of the 13th month onwards after installation or manufacture, is conditional upon the boiler having been serviced by a **competent person** approved at the time by the Health and Safety Executive,

in accordance with the manufacturer's recommendations. We strongly recommend regular servicing of your gas appliance, but where the condition is not met, any chargeable spare parts or components issued within the applicable guarantee period still benefit from a 12 month warranty from the date of issue by the manufacturer.

We recommend you complete and return as soon as possible your guarantee registration card. If your guarantee registration card is missing you can obtain a copy or record your registration by telephoning the Glow-worm Customer Service number 01773 828100.

Customer Service:

01773 828100

Technical Helpline:

01773 828300

General and Sales enquiries:

Tel. 01773 824639

Fax: 01773 820569

To register your Glow-worm appliance call:

0800 0732142

Benchmark places responsibilities on both manufacturers and installers. The purpose is to ensure that customers are provided with the correct equipment for their needs, that it is installed, commissioned and serviced in accordance with the manufacturer's instructions by competent persons and that it meets the requirements of the appropriate Building Regulations. The Benchmark Checklist can be used to demonstrate compliance with Building Regulations and should be provided to the customer for future reference.

Installers are required to carry out installation, commissioning and servicing work in accordance with the Benchmark Code of Practice which is available from the Heating and Hotwater Industry Council who manage and promote the Scheme.

Visit www.centralheating.co.uk for more information.



These instructions consist of, Installation, Servicing, Fault Finding, Replacement of Parts and Spares. The instructions are an integral part of the appliance and must, to comply with the current issue of the Gas Safety (Installation and Use) Regulations, be handed to the user on completion of the installation.

CONTENTS	DESCRIPTION	SECTION	PAGE
INTRODUCTION	Warnings		4
	Important Information		4
	Statutory Requirements		5
	Boiler Design		6
	Safety Devices		6
	Servicing, Maintenance and Spare Parts		6
INSTALLATION	Boiler Specification	1	7
	Boiler Dimensions & Hydraulic Schematic	2	8
	Boiler Location, Clearances and Ventilation	3	9
	Flue Options and Terminal Clearances	4	10
	Water System	5	12
	Installation Preparation	6	14
	Boiler Fixing	7	16
	Gas/Water Connections	8	16
	Safety Discharge Valve and Condensate Connections	9	18
	Flue Length Preparation and Installation	10	20
	Electrical Connection	11	36
	Commissioning	12	38
MAINTENANCE	Servicing	13	42
	Fault Finding	14	46
	Replacement of Parts	15	54
	Spare Parts	16	64
	Manual Handling	17	66
	Declaration of Conformity	-	67

WARNINGS

Gas Leak or Fault

Turn off the gas emergency control valve immediately. Eliminate all sources of ignition, i.e. smoking, blowlamps, hot air guns etc. Do not operate electrical lights or switches either on or off. Open all doors and windows, ventilate the area.

Metal Parts

This boiler contains metal parts (components) and care should be taken when handling and cleaning, with particular regard to edges.

Sealed Components

Under no circumstances must the user interfere with or adjust sealed parts.

Important Information

Gas Category

This boiler is for use only on G20 natural gas, but may be converted for use on G31 gas (Propane L.P.G.).

Gas Safety (Installation and Use) Regulations

In your own interests and that of safety, it is the Law that ALL gas appliances are installed by a **competent person** approved at the time by the Health and Safety Executive.

in accordance with the current issue of these regulations.

Control of Substances Hazardous to Health

Under Section 6 of The Health and Safety at Work Act 1974, we are required to provide information on substances hazardous to health.

The adhesives and sealants used in this appliance are cured and give no known hazard in this state.

Insulation Pads

These can cause irritation to skin, eyes and the respiratory tract.

If you have a history of skin complaint you may be susceptible to irritation. High dust levels are usual only if the material is broken.

Normal handling should not cause discomfort, but follow normal good hygiene and wash your hands before eating, drinking or going to the lavatory.

If you do suffer irritation to the eyes or severe irritation to the skin seek medical attention.

Manual Handling

With regards to the "Manual Handling Operations, 1992 Regulations", the appliance exceeds the recommended weight for a one man lift, refer to section 17 for more information.

Electrical Supply

The boiler MUST be earthed.

All system components shall be of an approved type and all wiring to current I.E.E. wiring regulations.

External wiring must be correctly earthed, polarised and in accordance with the relevant standards.

In GB, this is BS 7671.

In IE, this is the current edition of ETCI rules.

The boiler MUST be connected to a permanent 230V ac,

50Hz supply.

Connection of the whole electrical system of the boiler, including any heating controls, to the electrical supply MUST be through one common isolator and must be fused 3 Amp maximum.

Isolation should be by a double pole switched fused spur box, with a minimum gap of 3mm for both poles. The fused spur box should be readily accessible and preferably adjacent to the appliance. It should be identified as to its use.

Alternatively connection can be made through an unswitched shuttered socket and 3A fused 3-pin plug both to the current issue of BS 1363, provided they are not used in a room containing a bath or shower.

Wiring to the boiler must be PVC 85°C insulated cable, not less than 0.75mm² (24/0.20mm).

Testing and Certification

This boiler is tested and certificated for safety and performance. It is, therefore, important that no alteration is made to the boiler, without permission, in writing, by Glow-worm.

Any alteration not approved by Glow-worm, could invalidate the certification, boiler warranty and may also infringe the current issue of the statutory requirements.

CE Mark

This boiler meets the requirements of Statutory Instrument, No. 3083 The Boiler (Efficiency) Regulations, and therefore is deemed to meet the requirements of Directive 92/42/EEC on the efficiency requirements for new hot water boilers fired with liquid or gaseous fuels.

Type test for purposes of Regulation 5 certified by: Notified body 0087.

Product/production certified by: Notified body 0086.

The CE mark on this appliance shows compliance with:

1. Directive 90/396/EEC on the approximation of the laws of the Member States relating to appliances burning gaseous fuels.
2. Directive 73/23/EEC on the harmonisation of the Laws of the Member States relating to electrical equipment designed for use within certain voltage limits.
3. Directive 89/336/EEC on the approximation of the Laws of the Member States relating to electromagnetic compatibility.

Statutory Requirements

IMPORTANT

Where no British Standards exists, materials and equipment should be fit for their purpose and of suitable quality and workmanship.

The installation of this boiler must be carried out by a **competent person** in accordance the rules in force in the countries of destination.

Manufacturer's instructions must not be taken as overriding statutory requirements.

Statutory Requirements

In GB, the installation of the boiler must comply with the requirements of the current issue of BS6798 and be carried out by a **competent person** approved at the time by the Health and Safety Executive. as described in the following regulations:

The manufacturer's instructions supplied.

The Gas Safety (Installation and Use) Regulations.

The appropriate Buildings Regulations either The Building Regulations, The Building Regulations (Scotland), The Building Regulations (Northern Ireland).

The Water Supply (water fittings) Regulations 1999 and water byelaws 2000, Scotland.

The Health and Safety at Work Act, Control of Substances Hazardous to Health (COSHH).

The Current I.E.E. Wiring Regulations.

Where no specific instructions are given, reference should be made to the relevant British Standard Code of Practice.

In IE, the installation must be carried out by a **competent person** approved at the time by the Health and Safety Executive. and installed in accordance with the current edition of I.S.813 "Domestic Gas Installations", the current Building Regulations and reference should be made to the current ETCI rules for Electrical Installation.

GB: the following Codes of Practice apply:

BS4814, BS6798, BS5440 Part 1 and 2, BS5546 Part 1, BS5449, BS6891, BS6700, BS7074 Part 1 and 2, BS7593, BS7671.

IE: I.S.813, BS5546, BS 5449, BS 7074, BS 7593.

NOTE: For further information, see the current issue of the Building Regulations, approved document L1 (in the UK) and the following current issues of:

1) Central heating system specification (CheSS)

and

2) Controls for domestic central heating system and hot water. BRECSU.

Gas Supply

The gas installation must be in accordance with the relevant standards.

In GB, this is BS6891.

In IE, this is the current edition of I.S.813 "Domestic Gas Installations".

The supply from the governed meter must be of adequate size to provide a steady inlet working pressure of 20mbar (8in wg) at the boiler.

On completion, test the gas installation for tightness using the pressure drop method and suitable leak detection fluid, purge in accordance with the above standard.

Domestic Hot Water

All domestic hot water circuits, connections, fittings must be in accordance with the relevant standards and water supply regulations.

GB: Guidance G17 to G24 and recommendation R17 to R24 of the Water Regulations Guide.

IE: The current edition of I.S.813 "Domestic Gas Installations".

Heating System

In GB, it is necessary to comply with the Water Supply (Water Fittings) Regulations 1999 (for Scotland, the Water Byelaws 2000, Scotland).

To comply with the Water regulations your attention is drawn to: The Water Regulations guide published by the Water Regulations Advisory Service (WRAS) gives full details of the requirements.

In IE, the requirements given in the current edition of I.S.813 "Domestic Gas Installations" and the current Building Regulations must be followed.

Boiler Design

Boiler Design

This boiler is designed for use as part of a sealed water central heating system with fully pumped circulation. The pump, expansion vessel and associated safety devices are all fitted within the boiler. The optional integral programmer is designed for both simple operation and maximum control. Once the controls are set the boiler will operate automatically.

Condensate Drain

A plastic drain pipe must be fitted to allow discharge of condensate to a drain.

Condensate should, if possible, be discharged into the internal household draining system. If this is not practical, discharge can be made externally into the household drainage system or a purpose designed soak away, see section 9 for more details.

Plumbing from flue terminal

Like all condensing boilers this appliance will produce a plume of condensation from the flue terminal in cool weather. This is due to the high efficiency and hence low flue gas temperature of the boiler.

This is normal and not an indication of a fault.

Safety Devices

Electrical Supply Failure

The boiler will not work without an electrical supply.

Normal operation of the boiler should resume when the electrical supply is restored.

Reset any external controls, to resume normal operation of the central heating.

If the boiler does not resume normal operation press the reset button. If the boiler does not resume normal operation after this call your Installation/Service company or Glow-worm service.

Overheating Safety

The boiler software is designed to recognise the potential for an overheat lockout and will shutdown before this happens. To restart the boiler, press the reset button on the controls fascia.

If the boiler fails to resume normal operation and all external controls are calling for heat, then call your Installation/Service company or Glow-worm service.

Safety Discharge Valve

A safety discharge valve and discharge pipe are fitted to the boiler. This valve must not be touched. Should there be any discharge from the pipe, isolate the boiler electrical supply and call your installer or Glow-worm's own service organisation using the telephone number on the inside front cover of this booklet.

Frost protection

The appliance has a built in frost protection device that protects the boiler from freezing. With the gas and electric supplies ON and irrespective of any room thermostat setting, the frost protection device will operate the pump when the temperature of the boiler water falls below 8°C.

A timer is used so that the temperature can be checked periodically. After 10 minutes the pump will be stopped if the temperature is higher than 10°C or has already reached 35°C.

The burner will activate if the boiler temperature does not reach 10°C after 30 minutes or at any time if the temperature drops to 5°C.

The burner will switch off when the temperature reaches 35°C.

Condensate Drain Blockage

As a safety feature the boiler will stop working if the condensate drain becomes blocked. During freezing conditions this may be due to the forming of ice in the condensate drain external to the house. Release an ice blockage by the use of warm cloths on the pipe, the boiler should then restart.

Servicing, Maintenance and Spare Parts

Servicing and Maintenance

To ensure the continued efficient and safe operation of the boiler it is recommended that it is checked and serviced as necessary at regular intervals. The frequency of servicing will depend upon the particular installation conditions and usage. If this appliance is installed in a rented property there is a duty of care imposed on the owner of the property by the current issue of the Gas Safety (Installation and Use) Regulations, Section 35.

Servicing/maintenance should be carried out by a **competent person** approved at the time by the Health and Safety Executive, in accordance with the rules in force in the countries of destination.

To obtain service, please call your installer or Glow-worm's own service organisation using the telephone number on the inside front cover of this literature.

Spare Parts

Remember, when replacing a part on this appliance, use only spare parts that you can be assured conform to the safety and performance specification that we require. Do not use reconditioned or copy parts that have not been clearly authorised by Glow-worm.

If a part is required contact Glow-worm's own service organisation.

Please quote the name of the appliance, this information will be on the name badge on the front of the appliance.

If in doubt seek advice from the local gas company or Glow-worm's own service organisation using the telephone number on the inside front cover of this booklet.

1 Boiler Specification

BOILER SPECIFICATION	24cx	30cx
Lift weight	39kg (86lb)	41kg (91lb)
Total weight (installed)	44kg (97lb)	45kg (99lb)
Gas connection Ø O.D.	15mm. copper	15mm. copper
Heating flow and return connection Ø O.D.	22mm. copper	22mm. copper
Domestic hot water connection Ø O.D.	15mm. copper	15mm. copper
Condensate connection Ø I.D.	21.5mm. plastic	21.5mm. plastic
Safety valve discharge connection Ø O.D.	15mm. copper	15mm. copper
Heating circuit safety valve (preset)	3 bar (43/5lbf/in ²)	3 bar (43/5lbf/in ²)
Heating system minimum pressure	0.7bar (10.1lbf/in ²)	0.7bar (10.1lbf/in ²)
Maximum domestic hot water circuit	10bar (145lbf/in ²)	10bar (145lbf/in ²)
Minimum working pressure to obtain maximum domestic flow	1.0bar (2.9lbf/in ²)	1.0bar (2.9lbf/in ²)
Minimum working pressure to obtain domestic hot water	0.2bar (2.9lbf/in ²)	0.2bar (2.9lbf/in ²)
Specific water rate at 35° rise	9.8L/min.	12.3L/min.
Minimum flow rate around the central heating circuit at 20° rise	776L/hr.	1032L/hr.
Maximum domestic hot water temperature	62°	62°
Expansion vessel capacity	8 litres (1.76 gallons)	8 litres (1.76 gallons)
Expansion vessel charge pressure	0.5bar (7,3lbf/in ²)	0.5bar (7,3lbf/in ²)
Electrical supply	230V~50Hz fused 3A	230V~50Hz fused 3A
Electrical rating	180W fused 3A	180W fused 3A
EN60529 IP classification	IP X4D	IP X4D
Internal fuse rating on main PCB	2A	2A
Gas supply (governed meter only)	G20 - Natural Gas	G20 - Natural Gas
Gas category	II ₂ H3P	II ₂ H3P
Inlet gas working pressure	20mbar	20mbar
Burner % CO ₂ case on	9.3 nominal	9.3 nominal
Burner % CO ₂ case off	9.3 nominal	9.3 nominal
Approximate CH max. gas rate after 10 mins. from cold	1.94 m ³ /h	2.45 m ³ /h
	68.4 ft ³ /h	86.3 ft ³ /h
Approximate CH min. gas rate after 10 mins. from cold	0.53 m ³ /h	0.53 m ³ /h
	18.7 ft ³ /h	18.7 ft ³ /h
Flue type	C ₁₃ , C ₃₃ , C ₄₃ , C ₅₃ ,	C ₁₃ , C ₃₃ , C ₄₃ , C ₅₃ ,
NO _x	Class 5	Class 5
Heat output condensing mode	20.02kW	24.7kW
Heat input Nett Q = kW	DHW max. 24.12 min. 5	DHW max. 30.15 min. 5
	CH max. 18.31 min. 5	CH max. 23.12 min. 5
Heat output P = kW	DHW max. 24.00 min. 4.95	DHW max. 30.00 min. 4.95
	CH max. 18.00 min. 4.95	CH max. 22.94 min. 4.95
SEDBUK rating	Band A 90.3%	Band A 90.3%

13601

2 Boiler Dimensions & Hydraulic Schematic

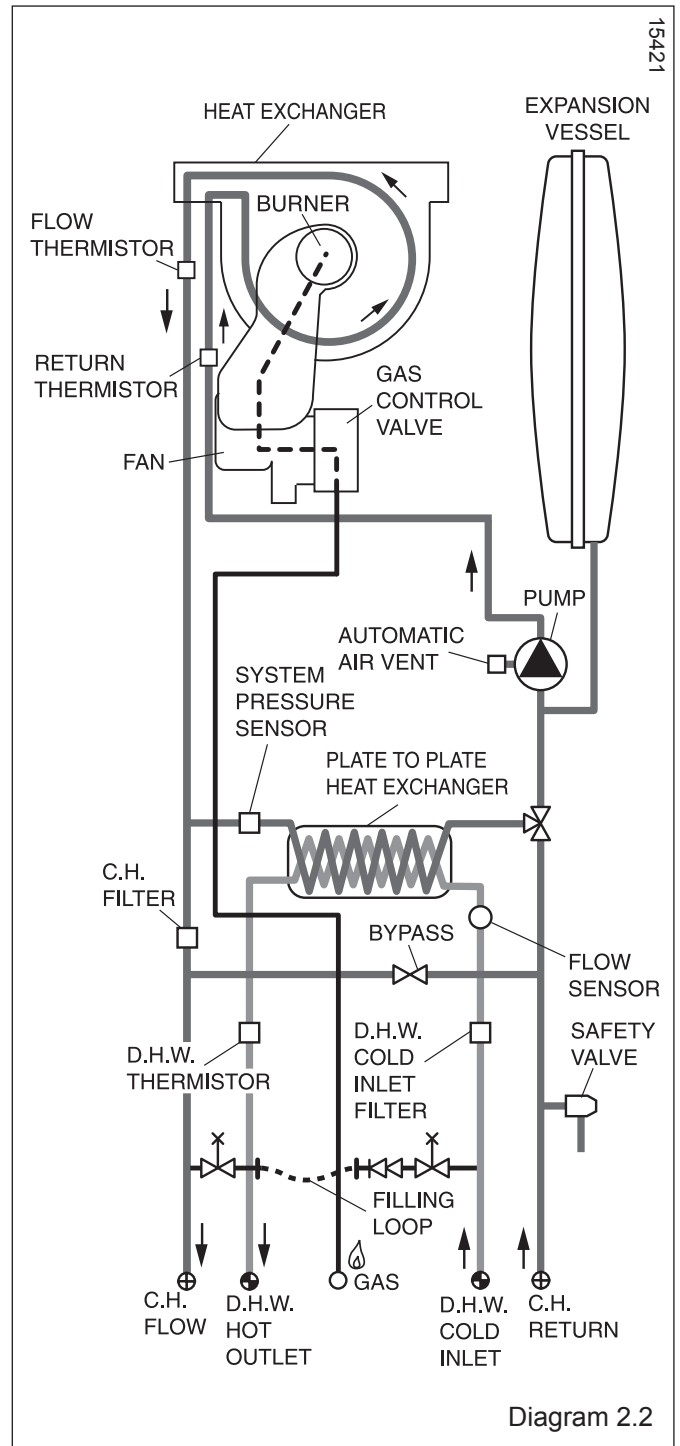
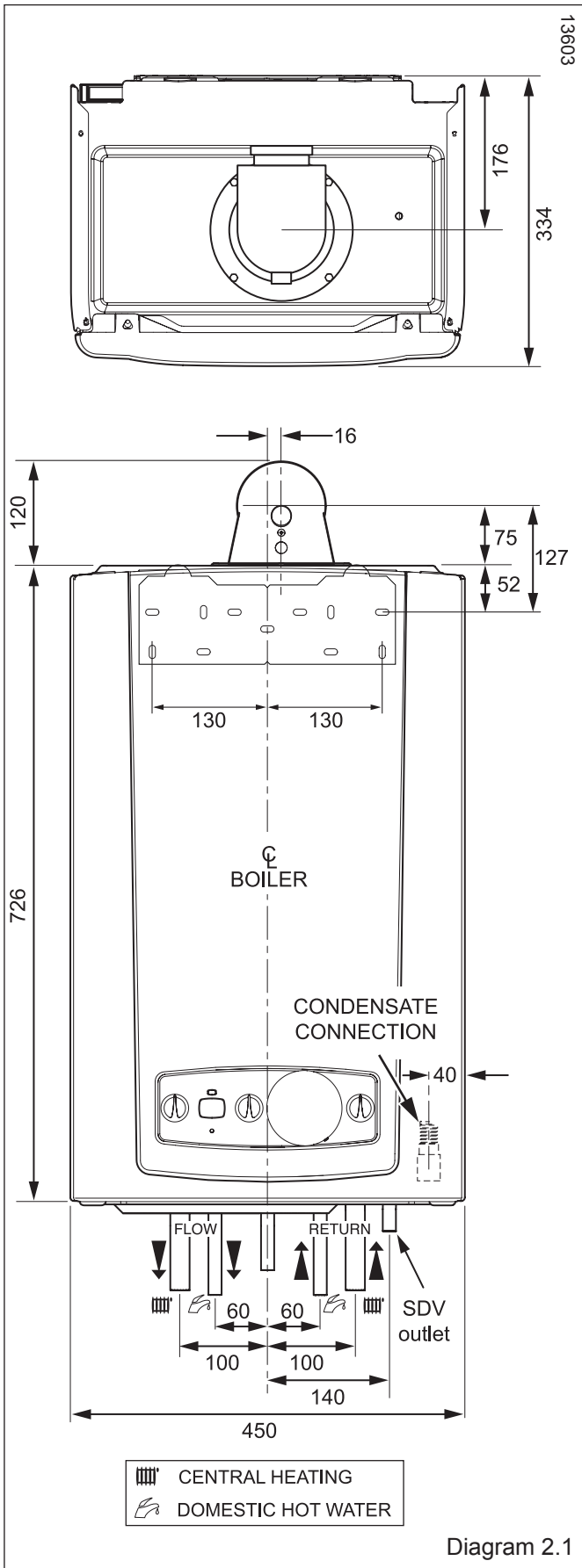

2.1 Boiler Dimensions & Hydraulic Schematic

All dimensions are given in millimetres (except as noted).

The general arrangement of the boiler is shown in diagram 2.1. and the hydraulic and gas schematic, diagram 2.2.

The data label is positioned on the front of the inner casing panel.

3 Boiler Location, Clearances and Ventilation

3.1 Location

This boiler is not suitable for outdoor installation.

This boiler may be installed in any room, although particular attention is drawn to the installation of a boiler in a room containing a bath or shower where reference must be made to the relevant requirements.

This boiler is suitable for installation in bathroom zones 2 and 3.

In GB this is the current I.E.E. WIRING REGULATIONS and BUILDING REGULATIONS.

In IE reference should be made to the current edition of I.S.813 "Domestic Gas Installations" and the current ETCI rules.

3.2 Clearances

The boiler should be positioned so that at least the minimum operational and servicing clearances are provided, see diagram 3.1.

Additional clearances may be beneficial around the boiler for installation and servicing.

For flue installations where external access is not practicable, consideration should be given for the space required to insert the flue internally, which may necessitate clearance larger than those specified in diagram 3.1.

3.3 Timber Frame Buildings

If the boiler is to be installed in a timber frame building it should be fitted in accordance with the Institute of Gas Engineers document IGE/UP/7/1998. If in doubt seek advice from local gas undertaking or Glow-worm.

3.4 Combustible Material

The boiler and flue are suitable for installation onto and through combustible materials provided that:-

- 1) Minimum 5mm clearance is maintained around the circumference of the flue (air intake).
- 2) The combustible surface and fixings are suitable for supporting the load.
- 3) The minimum clearances from the boiler case are maintained.

3.5 Room Ventilation

The boiler is room sealed so a permanent air vent is not required.

3.6 Cupboard or Compartment Ventilation

Due to the high efficiency and hence low casing temperature of this boiler, cupboard or compartment ventilation is not necessary.

Leave existing air vents.

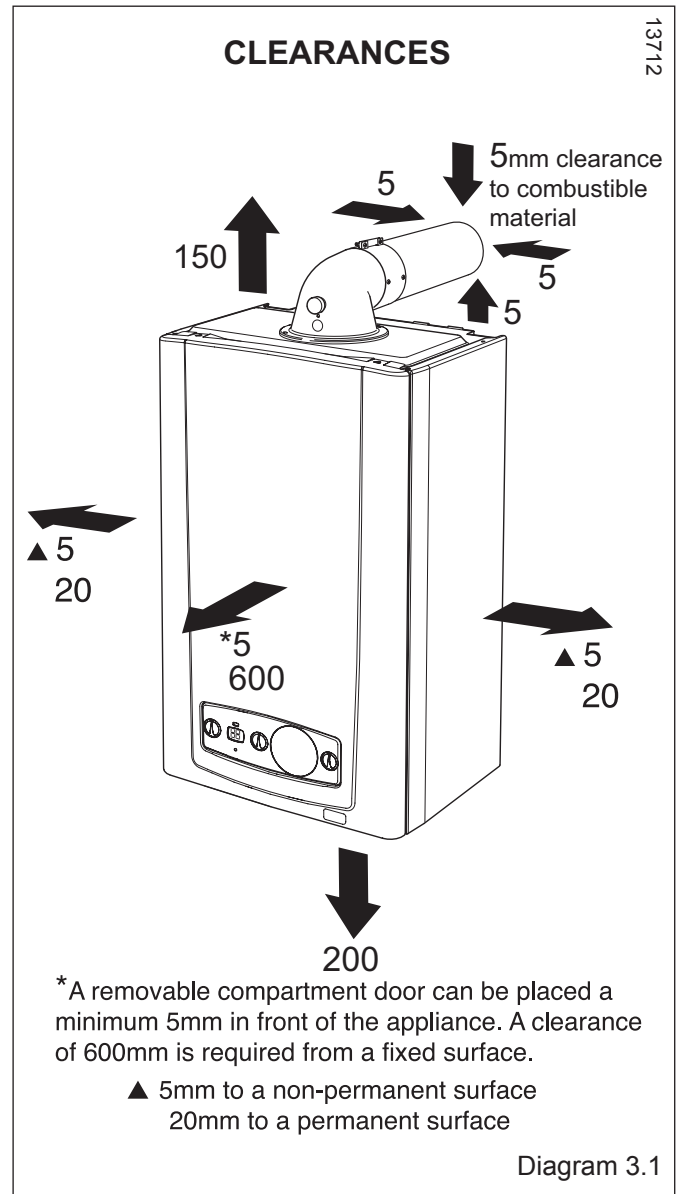

4 Flue Options and Terminal Clearances

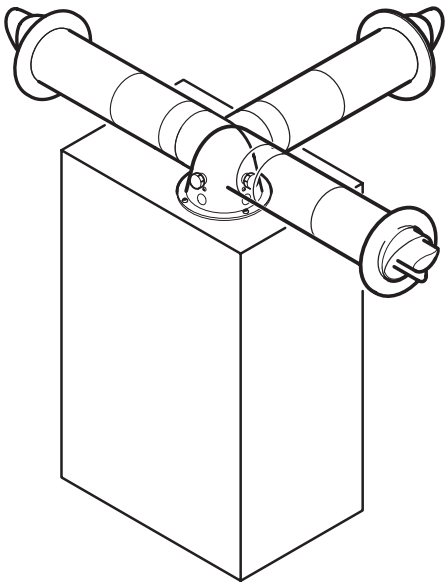

Top horizontal telescopic flue (Ø60/100)
Part No. A2043600 - Section 10, page 20

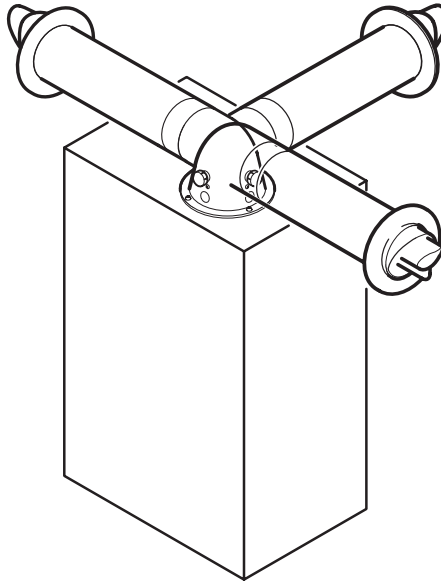

Top horizontal standard flue (Ø60/100)
Part No. A2043400 - Section 10, page 24

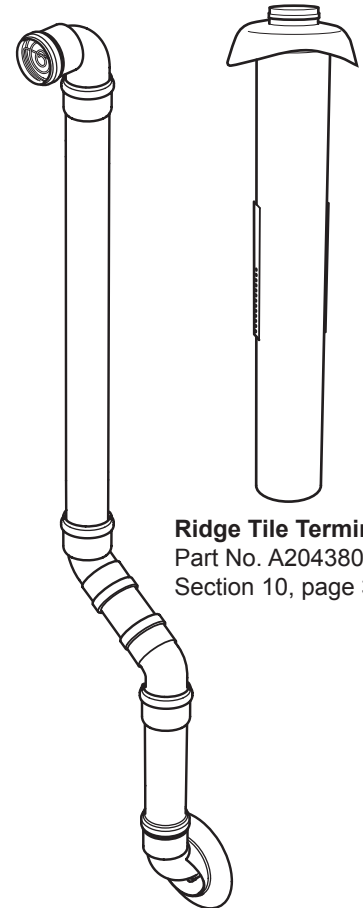

Ridge Tile Terminal
Part No. A2043800 -
Section 10, page 30

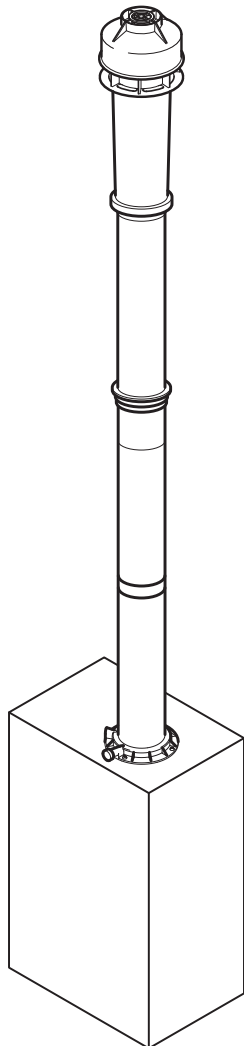

Vertical Flue
Vertical Flue Adapter, concentric flue (Ø60/100)
Part. No. A2024600 - Section 10, page 29
Vertical flue terminal kit, concentric flue (Ø60/100)
Part. No. 2000460480 - Section 10, page 29

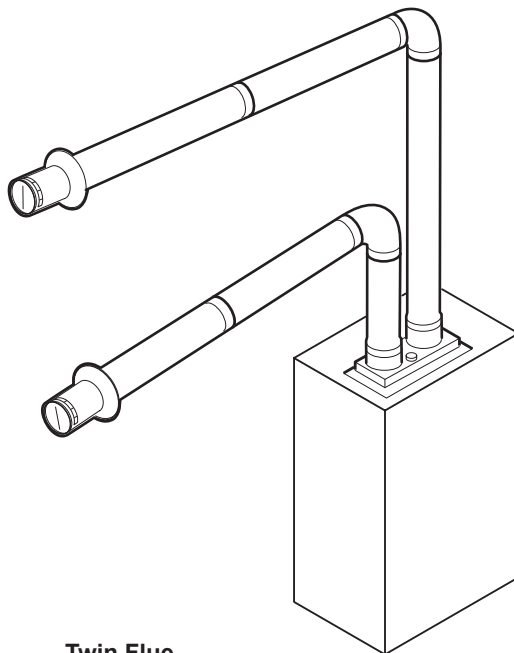

Twin Flue
Twin Flue Adapter, concentric flue (Ø80)
Part No. A2011000 - Section 10, page 33

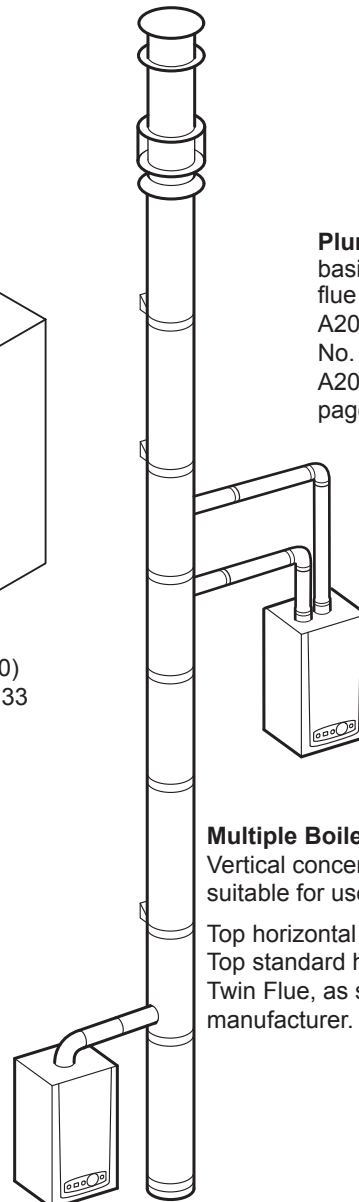

Multiple Boiler Chimney Flue
Vertical concentric stack flue
suitable for use with:-
Top horizontal telescopic flue,
Top standard horizontal flue,
Twin Flue, as specified by the
manufacturer.

Plume Management Kit
basic set, white, concentric
flue (Ø60/100) - Part No.
A2044100 for use with Part
No. A2043400 and Part No.
A2043600 - Section 10,
page 35

Diagram 4.1

4 Flue Options and Terminal Clearances

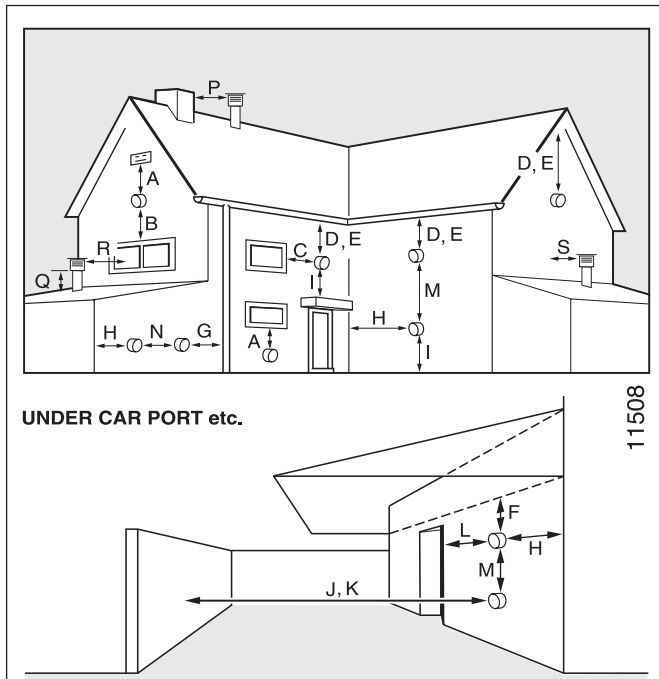

UNDER CAR PORT etc.

11508

HORIZONTAL FLUES

A	DIRECTLY BELOW AN OPENING, AIR BRICK, OPENING WINDOWS	300
B	ABOVE AN OPENING, AIR BRICK, OPENING WINDOWS	300
C	HORIZONTALLY TO AN OPENING, AIR BRICK, OPENING WINDOWS	300
D	BELOW GUTTER, DRAIN/SOIL PIPE	25
E	BELOW EAVES	25
F	BELOW A BALCONY OR CAR PORT	25
G	FROM VERTICAL DRAIN PIPES AND SOIL PIPES	25
H	FROM INTERNAL/EXTERNAL CORNERS	25
H*	TO A BOUNDARY ALONGSIDE THE TERMINAL	300
I	ABOVE ADJACENT GROUND OR BALCONY LEVEL	300
J*	FROM SURFACE OR A BOUNDARY FACING THE TERMINAL	600
K	FACING TERMINALS	1200
L	FROM OPENING (DOOR/WINDOW) IN CAR PORT INTO DWELLING	1200
M	VERTICAL FROM A TERMINAL	1500
N	HORIZONTALLY FROM A TERMINAL	300

VERTICAL FLUES

P	FROM ANOTHER TERMINAL	600
Q	ABOVE ROOF LEVEL	300
R	FROM ADJACENT OPENING WINDOW	1000
S	FROM ADJACENT WALL TO FLUE	300

Diagram 4.2

4.1 Flue Options

There are various flue options to choose from as illustrated in diagram 4.1. The flue lengths and installation are described in section 10.

4.2 Flue Terminal Position

In GB the minimum acceptable siting dimensions for the terminal from obstructions, other terminals and ventilation openings are shown in diagram 4.2.

In IE the minimum distances for flue terminal positioning must be those detailed in I.S.813 "Domestic Gas Installations".

The terminal must be exposed to the external air, allowing free passage of air across it at all times.

Being a condensing boiler some plumbing may occur from the flue outlet. This should be taken into consideration when selecting the position for the terminal.

Carports or similar extensions of a roof only, or a roof and one wall, require special consideration with respect to any openings, doors, vents or windows under the roof. Care is required to protect the roof if made of plastic sheeting. If the carport comprises of a roof and two or more walls, seek advice from the local gas supply company before installing the boiler.

H* and J* See diagram 4.2. These dimensions comply with the building regulations, but they may need to be increased to avoid wall staining and nuisance from plumbing depending on site conditions.

NOTE: If the flue terminal is positioned near a light source insects may enter the flue system. Where safe and practical to do so, advise the homeowner to check the flue outlet and clear visible insects from the terminal end.

4.3 Terminal Guard

A terminal guard is required if persons could come into contact with the terminal or the terminal could be subject to damage.

If a terminal guard is required, it must be positioned to provide minimum of 50mm clearance from any part of the terminal and be central over the terminal.

The guard should be similar to that shown in diagram 4.3.

A suitable guard is manufactured by: -

Tower Flue Components
 Morley Rd.
 Tonbridge
 Kent TN9 1RA.
 Size: 280mm x 165mm. Part No. CGDK3

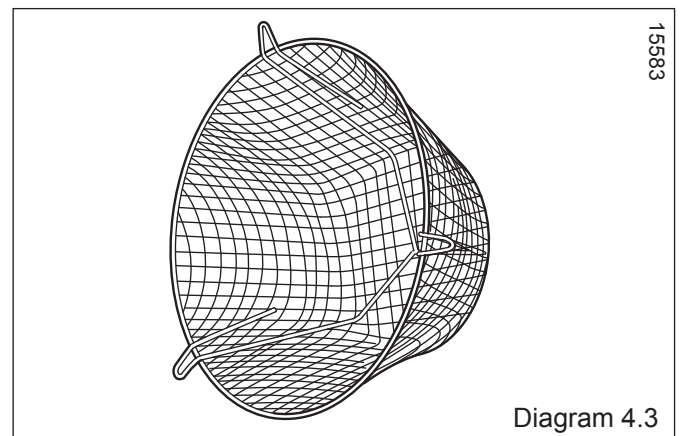

15583

Diagram 4.3

5 Water System

5.1 General

This boiler is designed for use as part of a sealed water central heating system with fully pumped circulation. The pump, expansion vessel and associated safety devices are all fitted within the boiler.

5.2 Safety Valve

The safety valve is an integral part of the boiler and it cannot be adjusted. The pipe from the safety discharge valve must not discharge above an entrance, window or any type of public access area.

5.3 Expansion Vessel

The boiler has an integral expansion vessel with a capacity of 8 litres (1.76 gallons), with a charge pressure of 0.5bar.

NOTE: The expansion vessel volume depends on the total water system volume and the initial system design pressure. In GB, Guidance on vessel sizing is also given in the current issue of BS5449 and BS7074 Part 1.

In IE, current edition of I.S.813 "Domestic Gas Installations".

5.4 Flow Rate

If it is necessary to alter the flow rate, the system can be fitted with a lockable balancing valve in the main flow or return pipes shown as valve "A" in diagram 5.1. The flow rate through the boiler must not be allowed to fall below that given in section 1 - Specification Table.

5.5 Bypass

The boiler is fitted with an automatic bypass which can be adjusted to suit your system requirements.

Ensure that under no circumstances does the flow rate drop below the figure specified, refer to section 1 - Specification Table.

5.6 Filling the Sealed System

The boiler is supplied with a filling device, see diagram 8.1.

This filling device is designed to enable the filling and pressurisation of the system in the event of loss of pressure.

NOTE: The water pressure at the boiler must be at least 1.2bar to enable filling the boiler to a minimum pressure. If not pressurisation must be carried out by an alternative filling loop.

Suitable external filling systems are shown diagrammatically, see diagram 5.2. The system should be pressurized to 1bar, indicated on the digital display with no heating demand.

5.7 Draining Points

Draining taps must be provided at all low points of the system, which will allow the entire system to be drained.

Draining taps shall be to the current issue of BS2879.

Drain points for the appliance are provided at the positions shown in diagram 8.1.

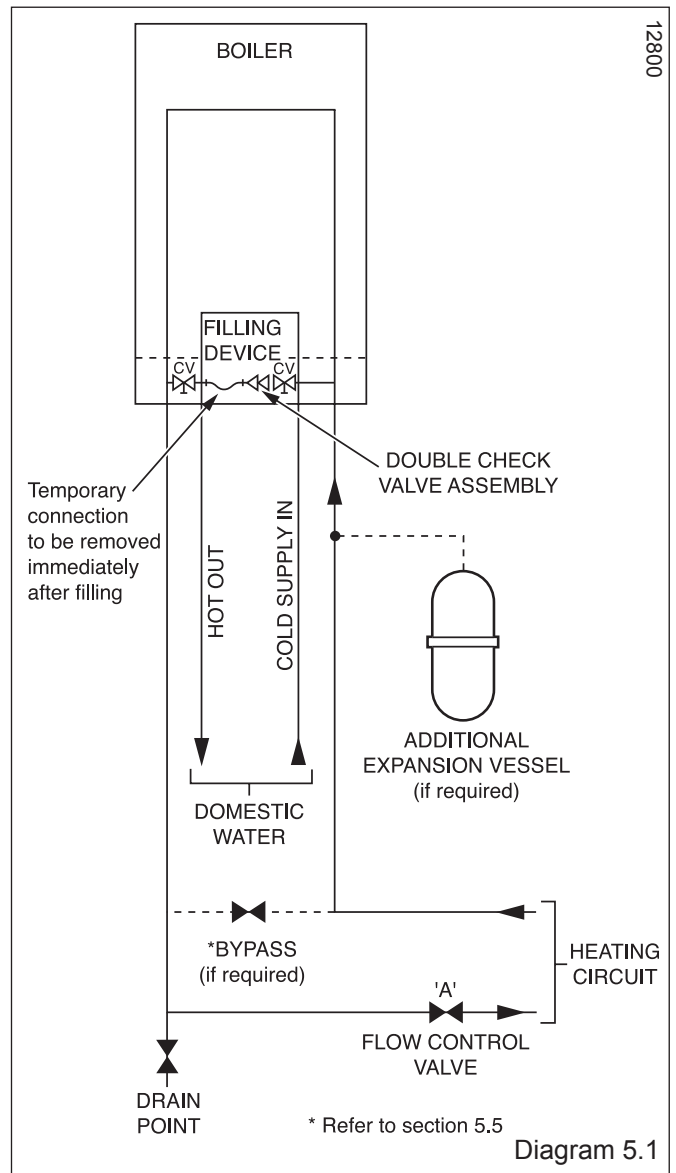

5.8 Water Treatment

Existing system- It is ESSENTIAL that prior to installing the new boiler the system is thoroughly flushed.

New system- For optimum performance after installation, the boiler and its associated central heating system should also be flushed.

Flushing should be carried out in accordance with BS7593: 2006 using a cleanser such as Sentinel X300 or X400, Fernox Restorer or Salamander corrosion guard cleaner.

IMPORTANT: Ensure all cleanser is removed from the whole system before adding an inhibitor.

For long-term corrosion protection, after flushing, an inhibitor suitable for stainless steel exchangers should be used, refer to the current issue of BS 5449 and BS 7593 on the use of inhibitors in central heating systems. Examples are Sentinel X100 Fernox Protector or Salamander corrosion guard inhibitor. Refer to the current issue of BS 5449 and BS 7593 on the use of inhibitors in central heating systems. Examples are Sentinel X100 Fernox Protector or Salamander corrosion guard inhibitor.

Ensure all cleanser is removed from the system.

5 Water System

5.9 Water Pressure

The minimum working pressure to obtain the maximum domestic flow is:-

24cxi 1.0bar

30cxi 1.0bar

The maximum working pressure of the domestic hot water circuit is 10 bar. If the cold water supply pressure exceeds this, then a pressure-reducing valve must be fitted in the supply to the boiler.

5.10 'Hard' Water Areas

The temperatures within the heat exchanger are limited by the boiler control system to minimise scale formation within the hot water pipework. However, in areas where the water is 'hard' (i.e. more than 200mg/litre), it is recommended that the hot water setting is reduced and that a scale reducer is fitted, refer to the manufacturer's instructions or consult the local water company for additional advice.

5.11 Domestic Water Flow Rate

The domestic hot water flow has a restrictor, factory fitted, which reduces the flow to a maximum of, 8.0 l/min for 24cx and 12.0 l/min for 30cx.

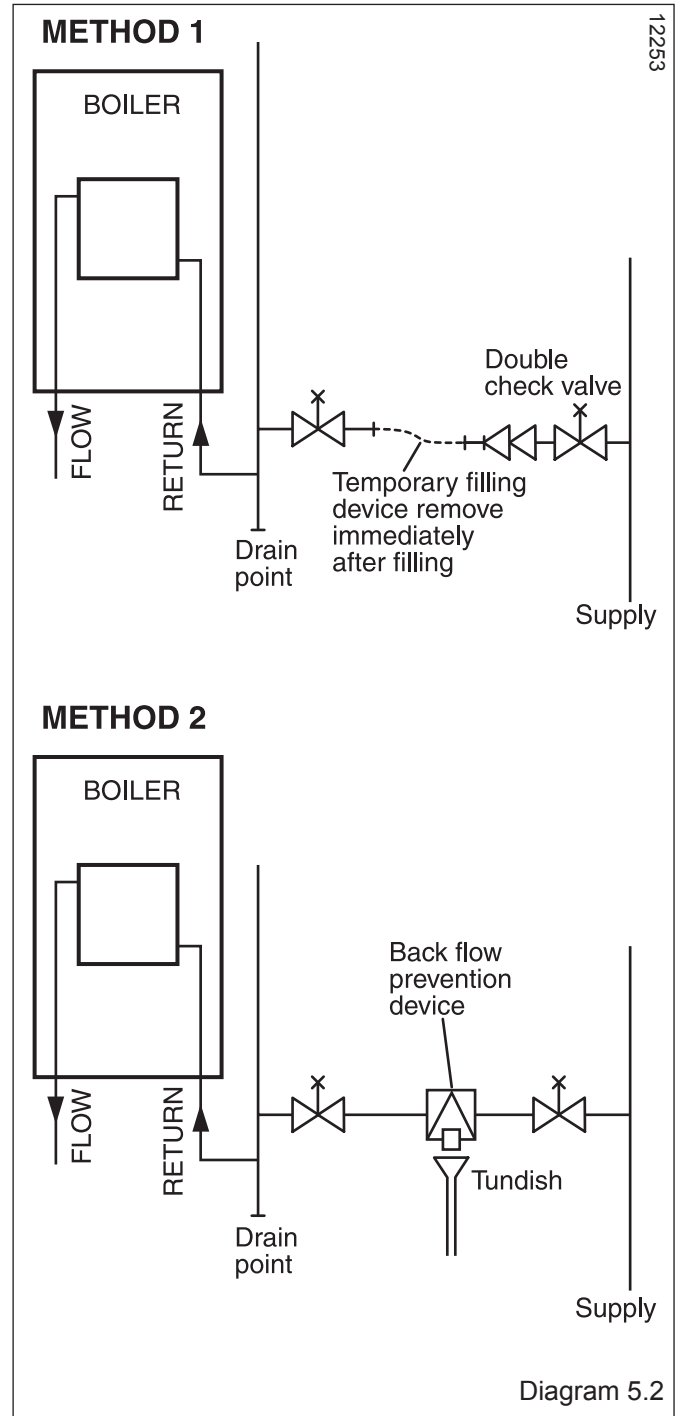

6 Installation Preparation

13646

Base Coverplate

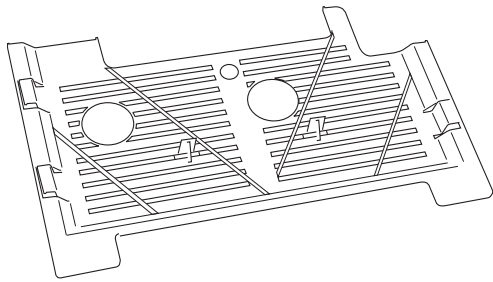

Hanging Bracket

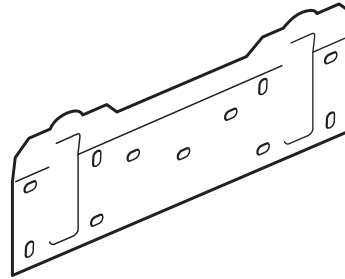

Gas and Water Isolating Valves 0020036801

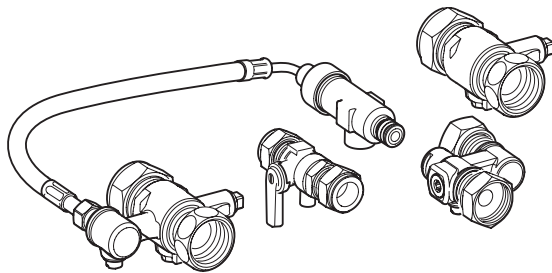

Electrical Cartridge

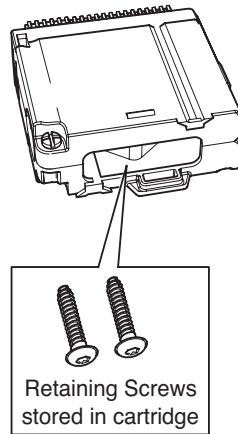

Pipe Pack 0020029671

- A - Central Heating x 2
- B - Domestic Hot Water Outlet
- C - Gas
- D - Domestic Cold Water Inlet
- E - Safety Discharge

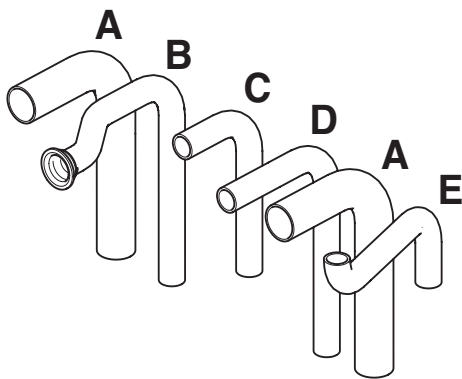

Loose Items Pack

- A - Wire Retaining Clip
- B - Union Nut and Sealing Washer
- C - Tap and Securing Screw
- D - Sealing Washers
- E - Gas Sealing Washer
- F - O Ring
- G - Union Nut

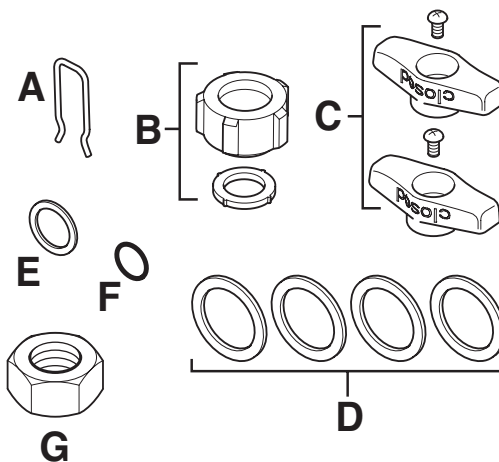

Documentation Pack (not illustrated)

Wall Template, User Instructions, Installation and Servicing Instructions.

Diagram 6.1

6 Installation Preparation

6.1 Appliance Pack

Please check the contents of packs as shown in diagram 6.1.

The packs are located in the top polystyrene packing.

Remove the carton sleeve and top pack then lift the boiler and its polystyrene base support out of the lower pack.

6.2 Site Requirements

The boiler mounting wall should be suitable for the weight of the appliance and be true and flat.

NOTE: Due to the varied site conditions we do not supply fixings and advise that the installer should supply those which are suitable.

6.3 Wall Template

Take the wall template from the document pack located within the top polystyrene packing and place in the desired position on the wall, giving due consideration to the required boiler clearances, see section 3, and the flue you are fitting.

Mark the position of the flue centre, if fitting a side flue, extend the flue centre line into the corner then 158mm along the adjacent wall.

For extended side flues, the flue hole centre should be determined by extending the dashed inclined line on the template to the side wall. This dashed line is drawn at 44mm/metre (2.5°) rise from the boiler. Where this line reaches the side wall, a horizontal line should be marked. The vertical centre line of the flue should then be marked at 176mm from the back wall.

To allow for the flue passing through the wall at this angle a 125mm hole should be drilled irrespective of internal or external installation.

Remove the wall template whilst drilling the flue hole.

6.4 Flue Hole Cutting

External access flue installation can use a 105mm diameter core drill.

Internal access only flue installation will need a 125mm diameter core drill.

NOTE: The flue is designed with an internal fall of 44mm/metre (2.5°), therefore the hole can be drilled horizontally.

If flue extension pipes are to be used then a core drill size of 125mm is required. This will allow the extension pieces to slope at 44mm/metre (2.5°) towards the boiler.

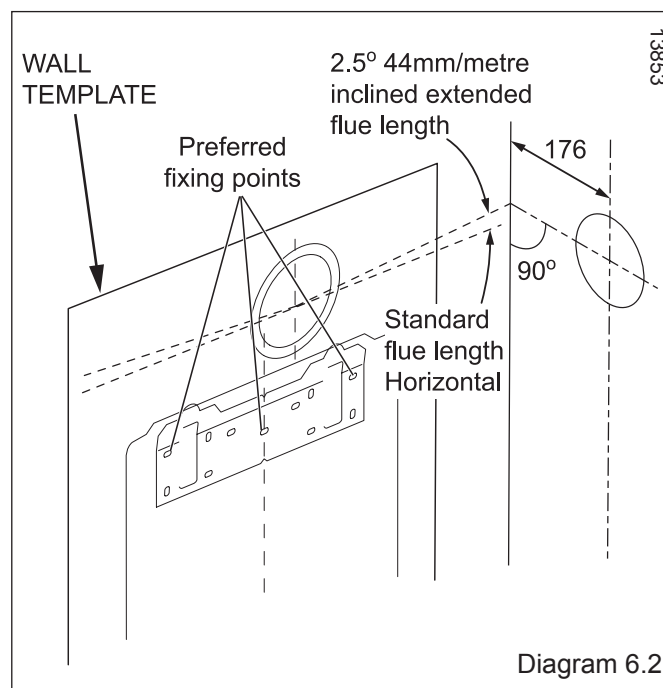

7 Boiler Fixing

7.1 Hanging Bracket Fixing

The Wall Hanging Bracket is supplied in the main boiler packaging at the rear of the boiler.

Reposition the wall template over the flue hole and mark the position of the fixing holes for the hanging bracket, see diagram 7.1.

Drill fixing holes and insert suitable wall plugs.

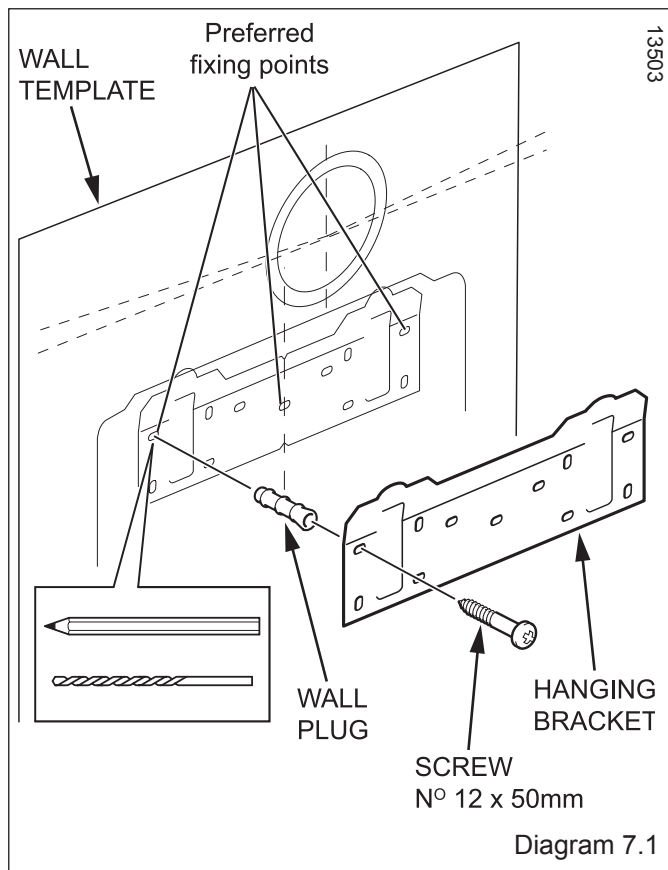

7.2 Boiler Hanging

IMPORTANT: With regards to the Manual Handling Operations, 1992 Regulations, the following lift operation exceeds the recommended weight for a one man lift, refer to section 17 Manual Handling.

Lifting the boiler into position, lean the top of the boiler slightly to the wall and position just above the hanging bracket. Lower the boiler slowly and engage onto the hanging bracket, see diagram 7.2.

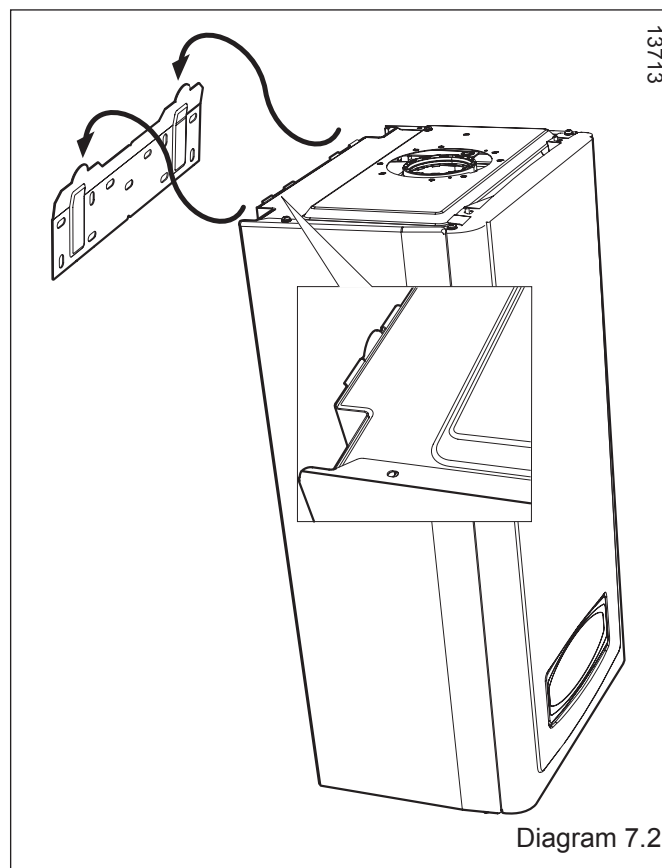

8 Gas / Water Connections

8.1 Systems Connection

Remove the protective caps from the boiler connections.

NOTE: The appliance may contain a small amount of water, place a water container beneath the boiler connections

Assemble and secure the pre formed copper tails to their respective isolation valves making sure of their correct orientation, see diagram 8.1.

Fit the isolation valves/copper tails with seals to the appliance as shown in diagram 8.1

Make sure that all connections are secured in the sequence shown on diagram 8.1.

There are flats on the body of the valves for locating a spanner to aid tightening.

Fit the 'O' ring seal from the loose items pack to the Double Check Inlet Valve assembly then secure into isolation valve with wire retaining clip, see diagram 8.1.

Fit the Central Heating Isolation Valve handles and secure with screws provided.

NOTE: Make sure the test and drain points are accessible, refer diagram 8.1.

Plumb the system pipe work to the copper tails.

NOTE: Do not subject service cocks to heat.

Flush out the domestic hot water and the heating systems, refer to section 5.8.

The whole of the gas installation, including the meter, should be inspected, tested for tightness and purged in accordance with the current issue of BS6891 and in IE the current edition of I.S.813 "Domestic Gas Installations".

8 Gas / Water Connections

13643

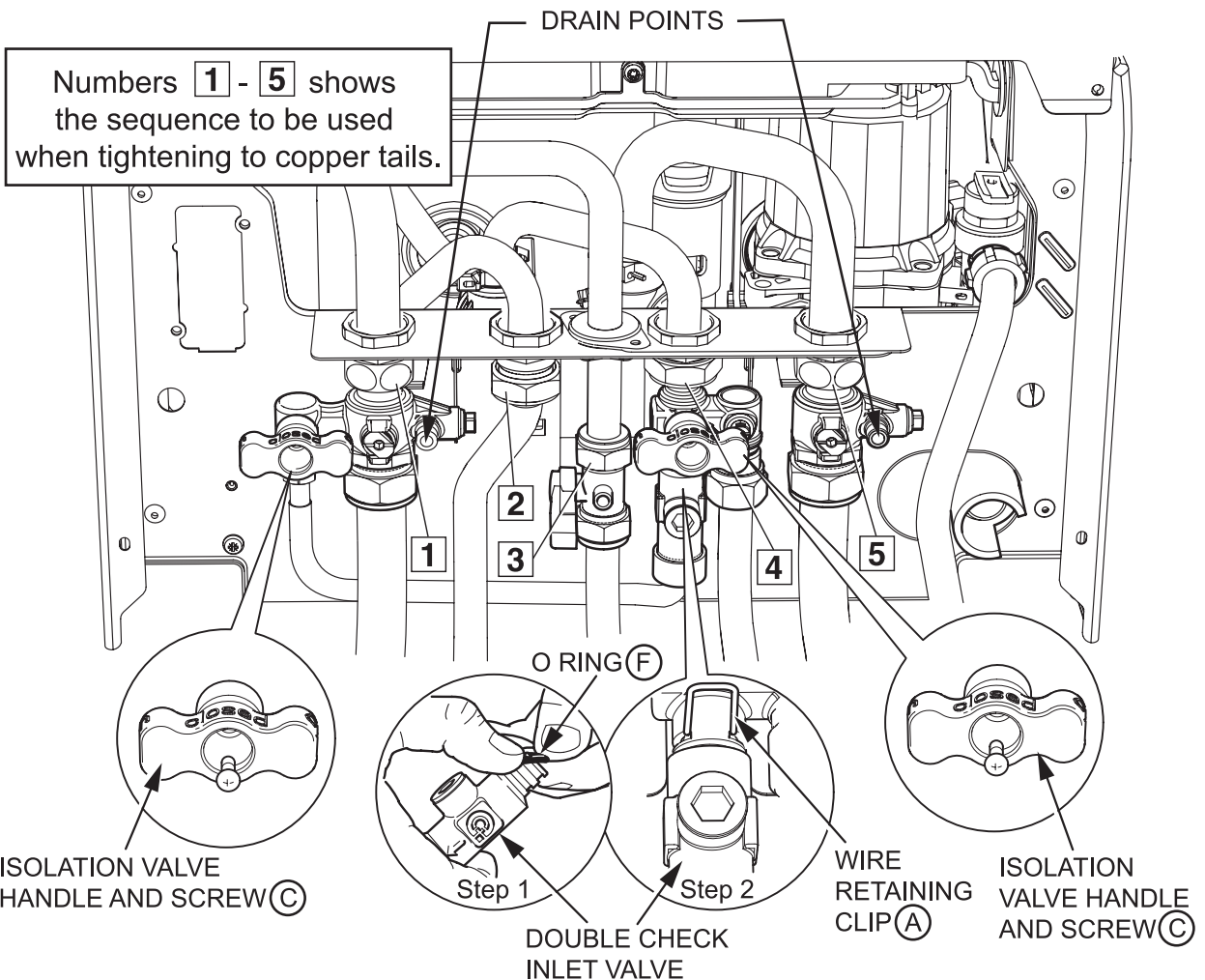
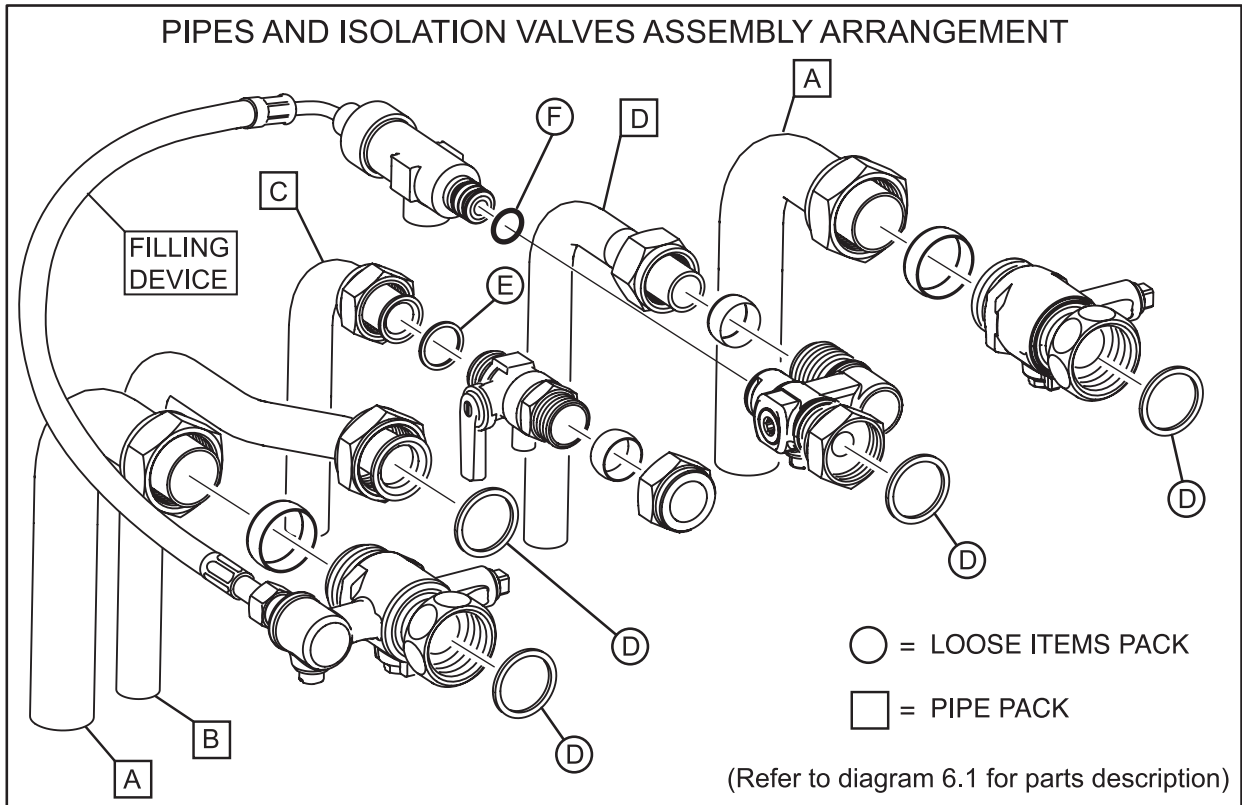

Diagram 8.1

9 Safety Discharge Valve & Condensate Connections

9.1 Safety Discharge Valve

Take the safety discharge pipe, supplied in the pipe pack and the union nut and seal, supplied in the loose items pack and fit as shown in diagram 9.1.

This must be extended, using not less than 15mm o.d. pipe, to discharge, in a visible position, outside the building, facing downwards, preferably over a drain.

To ease future servicing it is advisable to use a compression type fitting to extend the safety discharge valve tube.

The pipe must have a continuous fall and be routed to a position so that any discharge of water, possibly boiling, or steam cannot create any danger to persons, damage to property or external electrical components and wiring.

9.2 Condensate Trap and Siphonic Drain Connection

The condensate drain connection is behind the pump at the rear of the boiler, see diagram 9.2. A flexible condensate outlet pipe is fitted and should be used to couple the condensate trap and siphonic drain to a 22mm to 25mm O.D. non corrosive plastic pipe (overflow pipe).

IMPORTANT: Please remove the bung from the flexible pipe before fitting to a drain outlet pipe.

NOTE: the pipe should have a fall of a least 2.5° 44mm/metre away from the boiler.

Condensate should, if possible be discharged into the household internal drainage system. If this is not practicable, discharge can be allowed into the external household drains or a purpose designed soak away, refer to diagram 9.3.

It is recommended that any external condensate drain pipe is protected and also preferably of 32mm diameter, to prevent freezing in adverse weather conditions.

The condensate is discharged periodically in 'slugs' by siphonic action.

It is not necessary to provide air breaks or extra traps in the discharge pipe as there is already a 75mm high trap inside the boiler. Fitting an extra trap may cause the boiler siphon to work incorrectly.

Refer to BS5546 or BS6798 for advice on disposal of boiler condensate.

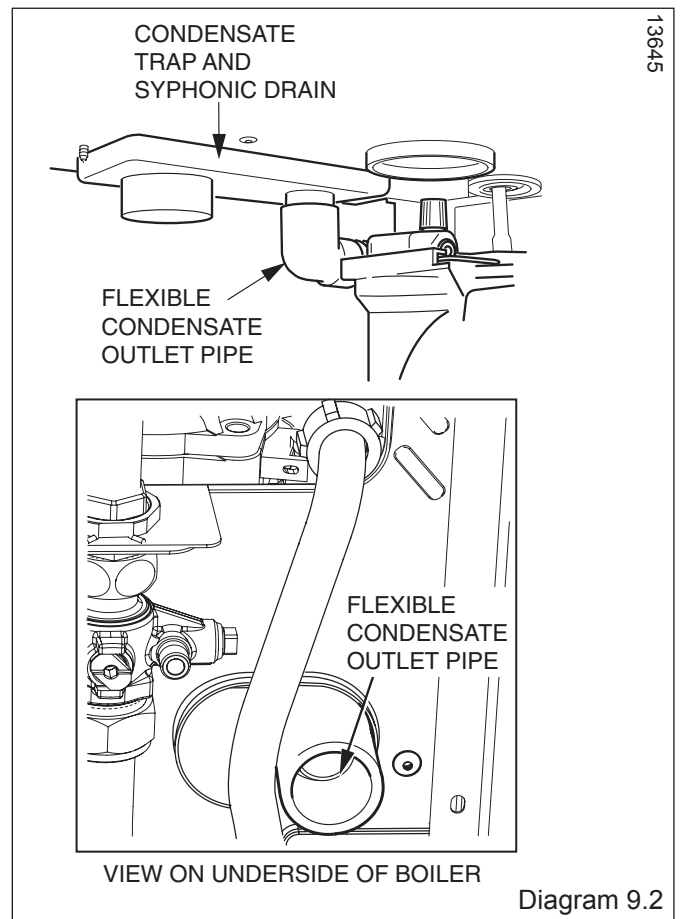
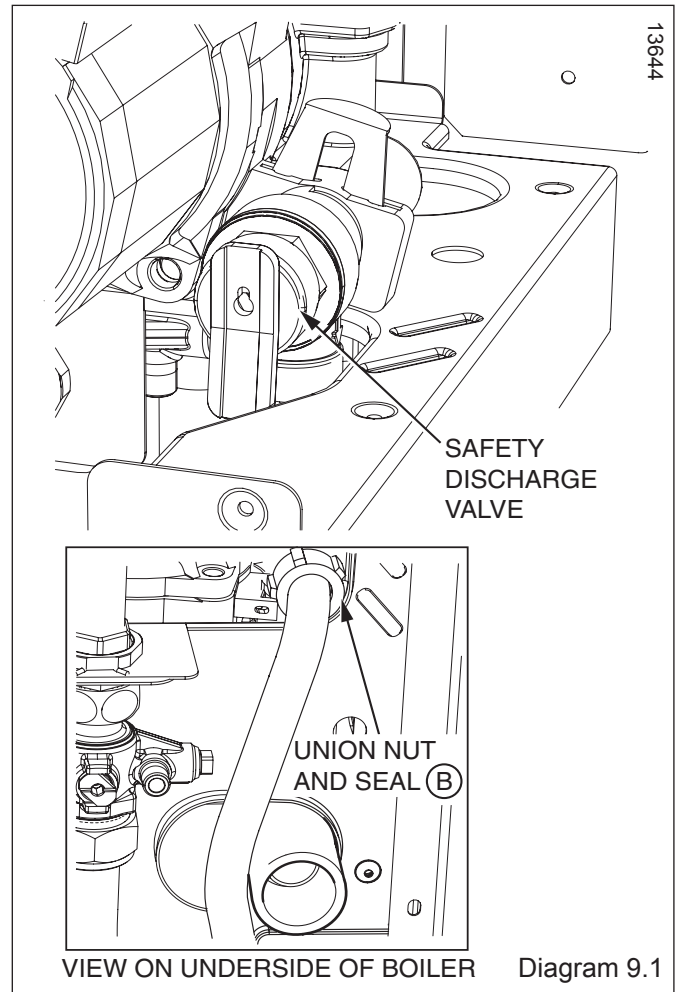

9 Safety Discharge Valve & Condensate Connections

13000

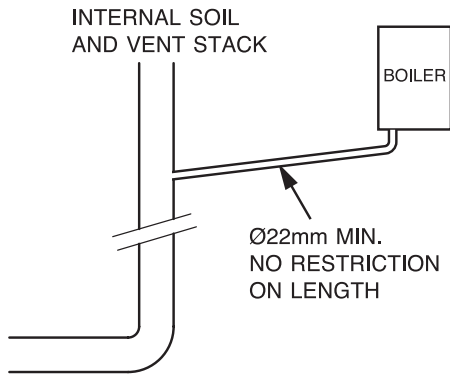

Internal Soil and Vent Pipe

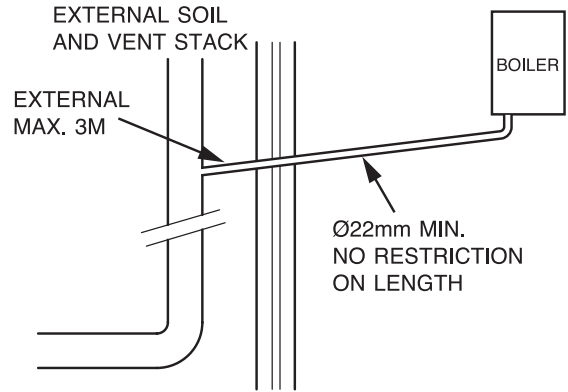

External Soil and Vent Pipe or Rainwater Pipe

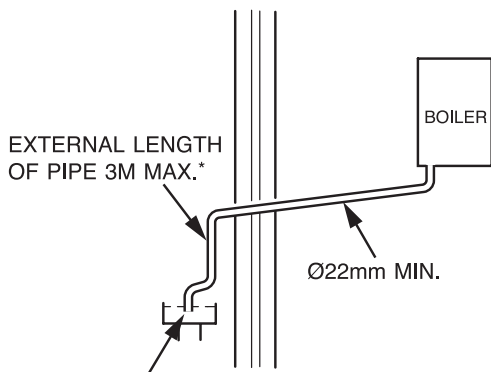

OPEN END OF PIPE DIRECT INTO GULLEY BELOW GROUND BUT ABOVE WATER LEVEL

*NOTE: FOR EXTENDED PIPE RUNS 32mm DIA. PIPE SHOULD BE USED.

External Termination to a Gully or Hopper

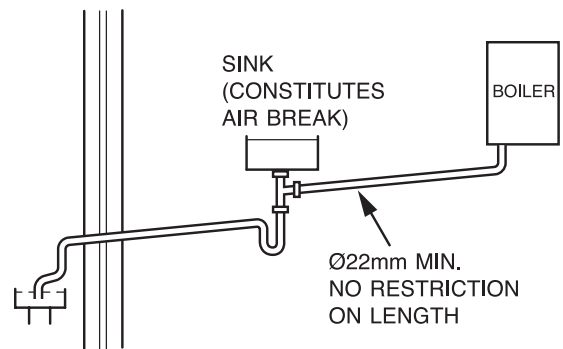

Internal Termination into Combined Sink Waste

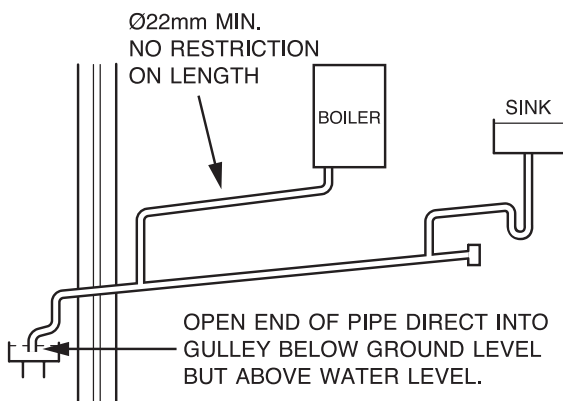

Internal Termination Downstream of Sink Waste

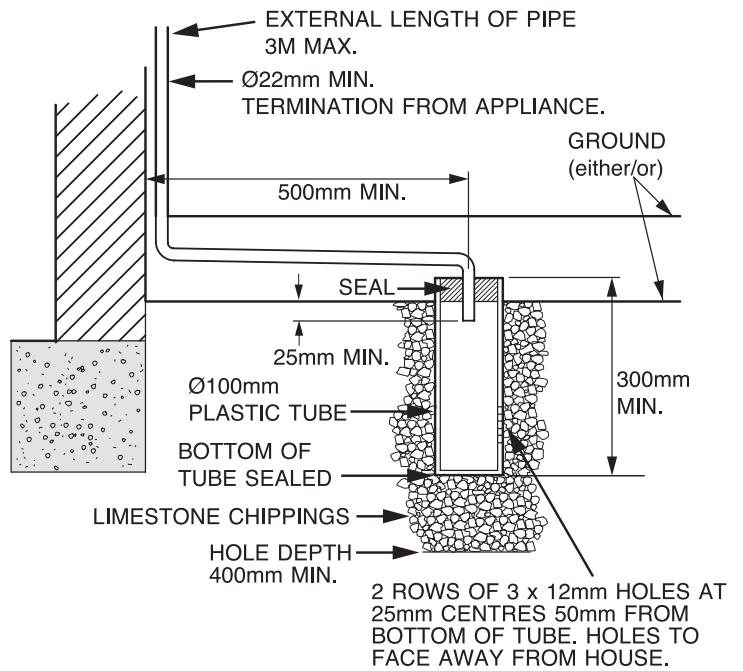

External Termination into Soakaway

NOTE: PIPEWORK SHOULD ALWAYS FALL AWAY FROM BOILER BY AT LEAST 2.5°
44mm FOR EVERY 1M.

Diagram 9.3

10 Telescopic Flue - Length, Preparation and Installation

Horizontal Telescopic Flue

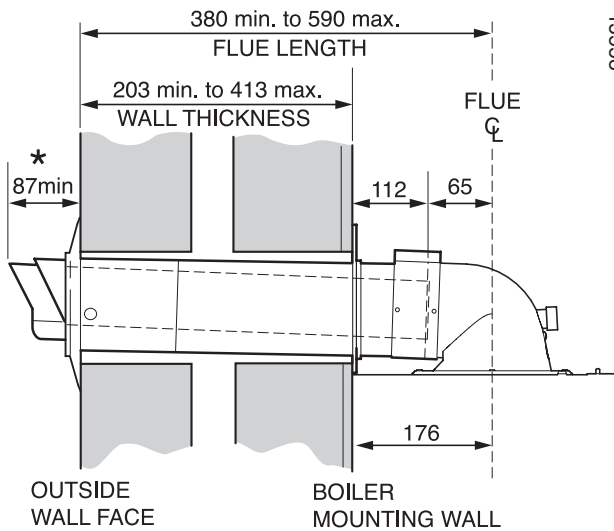

13558

* NOTE. If necessary, it is permitted to increase this dimension to 600mm max.

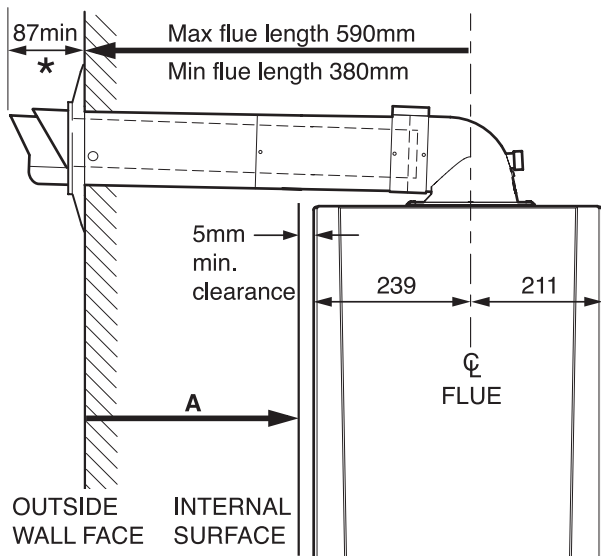

13559

A	
Max. distance from outside wall face to min clearance. LH - 346mm RH - 374mm	Min. distance from outside wall face to min clearance. LH - 136mm RH - 164mm

Diagram 10.1

10.1 Flue Length

The maximum permissible horizontal flue length is 10 metres plus the flue terminal assembly, this can be achieved by use of the accessories, see diagram 10.3.

However should an additional 87.5° or 2 x 45° elbows be used then the length **MUST** be reduced by 1metre.

The diagram 10.1 shows the length achievable by using the kit A2043600.

When extension pipes are used the flue system must be designed to have a continuous fall to the boiler of at least 2.5° 44mm/metre to allow condensate to run back into the boiler and out via the condensate drain.

The flue can be installed from inside the building, when access to the outside wall face is not practicable.

The diagram 10.1 illustrates the lengths achievable without the use of extensions or elbows.

Multiple Boiler Chimney Flue Length

The flue length must be calculated and installed according to the relevant standards EN 13384-1 and 2 (C43 flue systems only) with reference to the table below and the manufacturers instructions supplied.

The appliance maximum flue length must be included when calculating the overall design of the flue system.

NOTE: The horizontal flue terminal must be removed, see diagram 10.2.

MODEL	24cx	30cx
Exhaust mass rate (g/s)		
At Min Thermal Load (40C°/30°C)	2.30	2.36
At Max Thermal Load (80C°/60°C)	11.30	14.20
Exhaust temperature (°C)		
At Min Thermal Load (40C°/30°C)	56.0	63.0
At Max Thermal Load (80C°/60°C)	76.0	75.0

10 Telescopic Flue - Length, Preparation and Installation

12841

Top Outlet Horizontal Concentric Flue Packs:
A2043600 Horizontal telescopic flue pack.

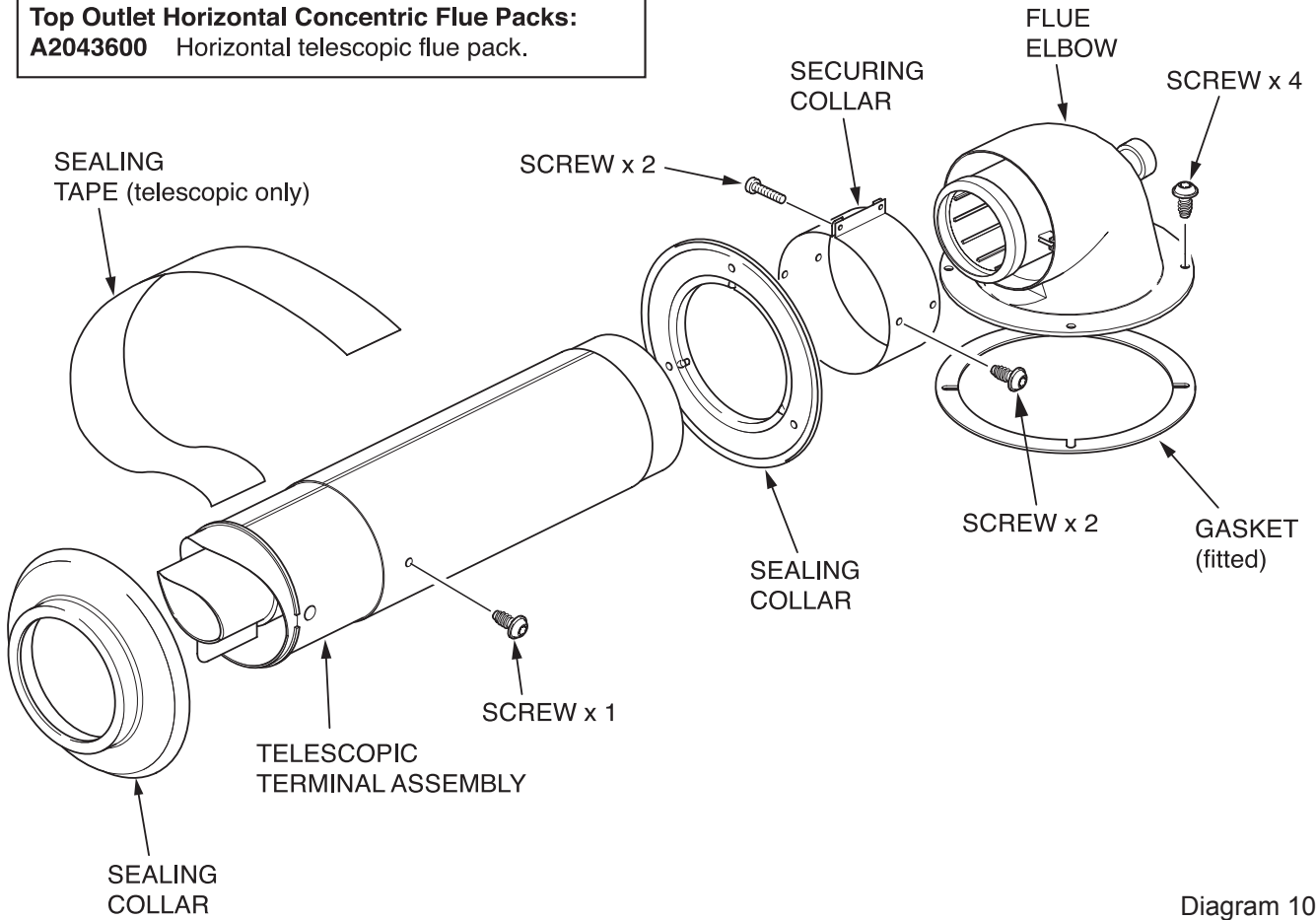

Diagram 10.2

15418

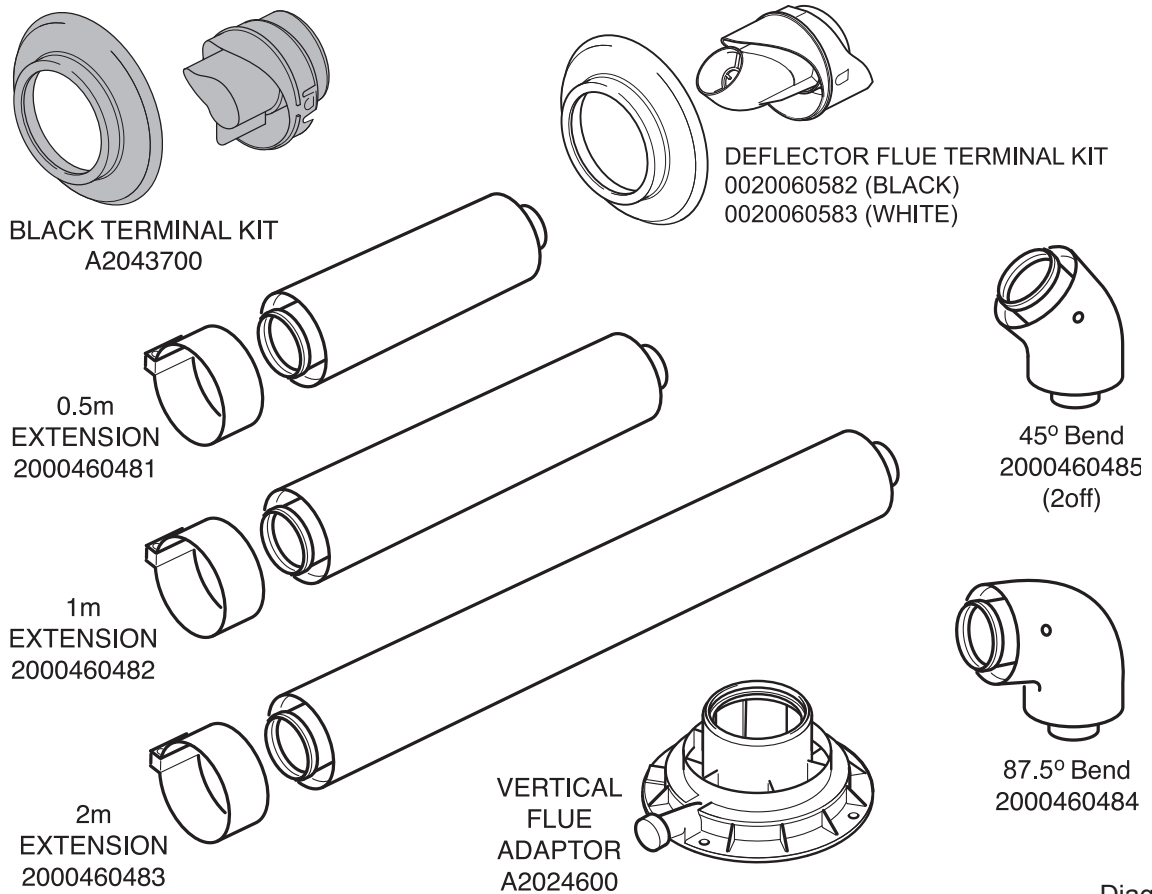

Diagram 10.3

10 Telescopic Flue - Length, Preparation and Installation

10.2 Horizontal Telescopic Flue - A2043600

Refer to diagram 10.2 for kit contents.

10.3 REAR Flue

If a wall thickness is between 203mm min. to 413mm max. then the flue can be used without extensions.

With the flue elbow temporarily fitted, measure the distance from the outside wall to the butt joint, see diagram 10.4. If the measurement 'Y' exceeds 525mm, then the appropriate length of extension pipe is required.

If the dimension is less than 315mm DO NOT cut the flue, it can project to a maximum of 600mm, refer to diagram 10.5. If this is not desirable then a Standard flue MUST be used and cut to length.

10.4 SIDE Flue

With the flue elbow temporarily fitted, measure the distance from the outside wall to the butt joint, see diagram 10.6. If the measurement 'Y' exceeds 525mm, then the appropriate length of extension pipe is required.

If the dimension is less than 315mm DO NOT cut the flue, it can project to a maximum of 600mm, refer to diagram 10.5. If this is not desirable then a Standard flue MUST be used and cut to length.

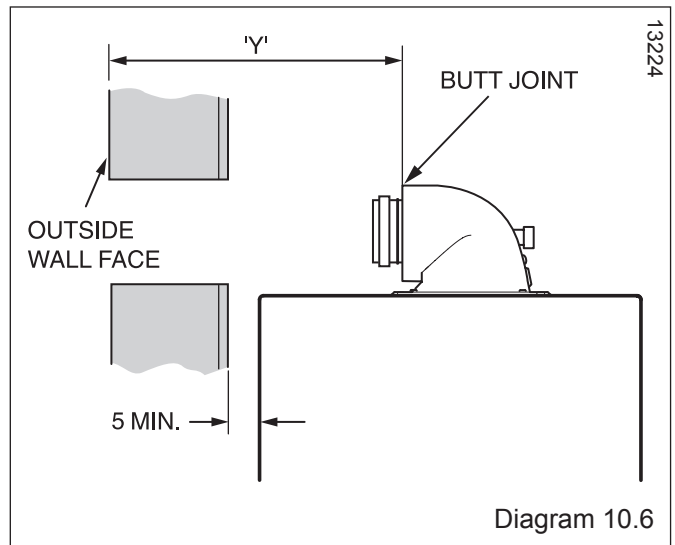
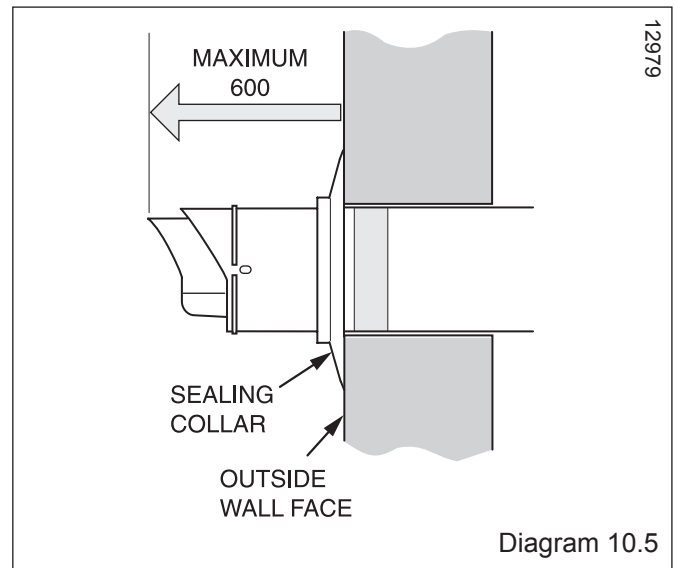
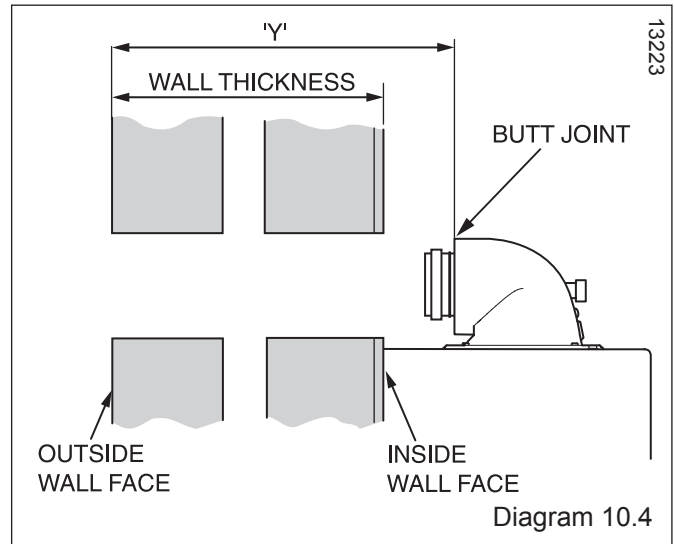

10 Telescopic Flue - Length, Preparation and Installation

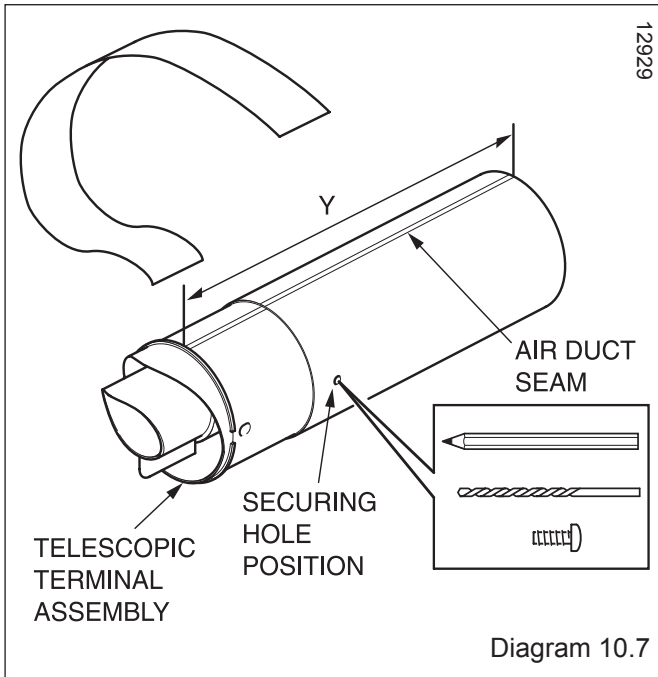

10.5 Flue Fitting

IMPORTANT:

The flue seals are sensitive to mineral oil based lubricants. **Do not grease the seals.** If the seals do need to be lubricated **use only water.**

During the installation of the flue system, ensure that debris such as mortar, filings or swarf are cleared from the flue system before completion.

Inspect the flue pipes before fitting and do not install damaged or dented flue components.

When assembling the flue system, ensure that the inner seals are not damaged, do not install a flue component with a damaged seal.

When fitting flue elbows ensure that they are fitted at the correct angle to avoid strain, this will ensure that the seal fits correctly preventing leakage.

With the air duct seams aligned and the flue set to the required length 'Y', mark the securing hole position in the air duct. Drill a 3mm diameter hole at this position, take care not to pierce the inner flue duct. Secure with screw provided and tape the joint, see diagram 10.7.

Fit the sealing collar onto the locating ring on the flue terminal, see diagram 10.8.

With the flue elbow removed, push the flue assembly into the wall, externally or internally, until the end of the assembly protrudes a short way from the inside face of the wall. This will enable the internal trim ring (if required) to be positioned and allow the flue assembly to be drawn back up to the flue elbow.

Secure the flue elbow in position on top of the boiler with the four screws supplied.

Draw the flue assembly from wall and engage the flue duct into the elbow and butt fit between the air duct and flue elbow. Fit the securing collar into position.

Ensuring correct alignment of the flue, mark through two of the pre drilled holes in the securing collar.

Remove securing collar and drill two 3mm diameter holes one in the elbow and one in the air duct, take care not to pierce the inner flue duct. Fit the securing collar and secure with screws provided, see diagram 10.9.

Slide the internal trim ring back against the wall, securing in place with a small amount of sealant if required.

Insert the flue duct into the air duct terminal assembly, remembering to engage the catch within the terminal. Check that the outer rubber sealing collar makes an effective seal against the wall face.

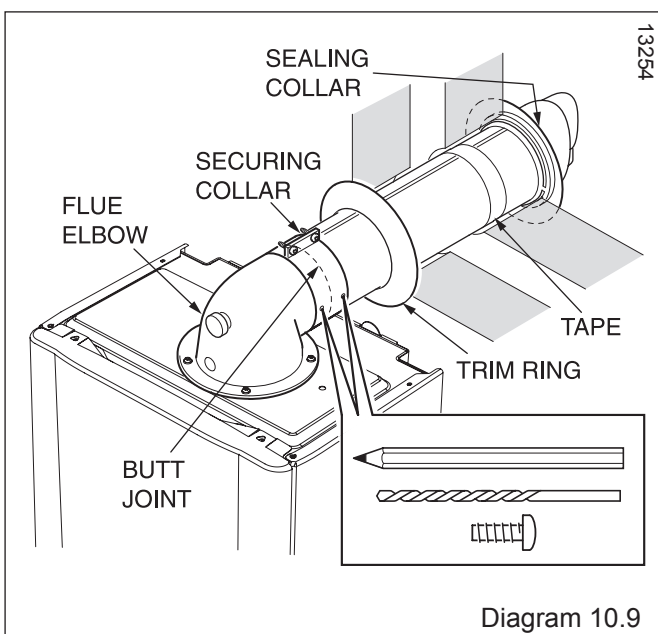
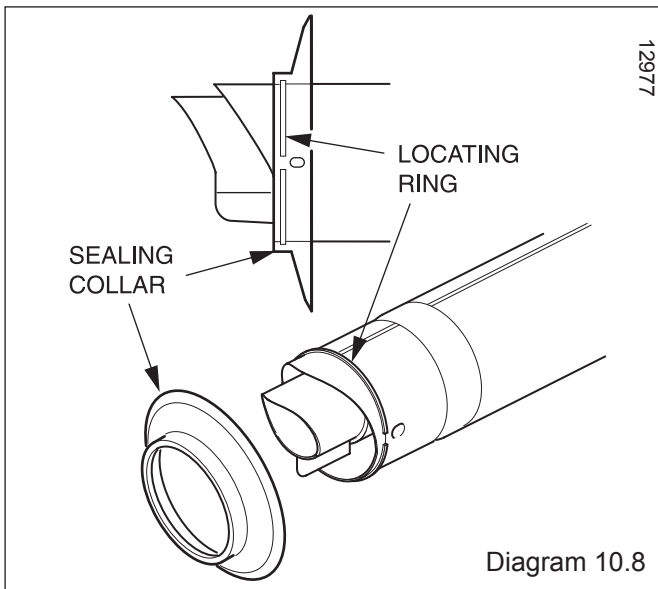

10 Standard Flue - Length, Preparation and Installation

Standard Horizontal Flue

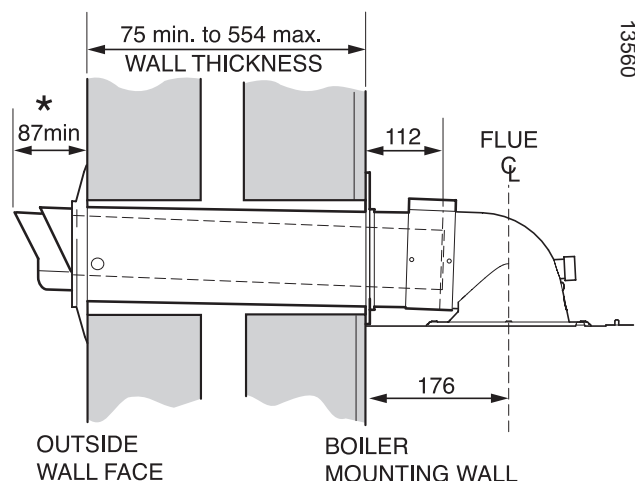

13560

* NOTE. If necessary, it is permitted to increase this dimension to 600mm max.

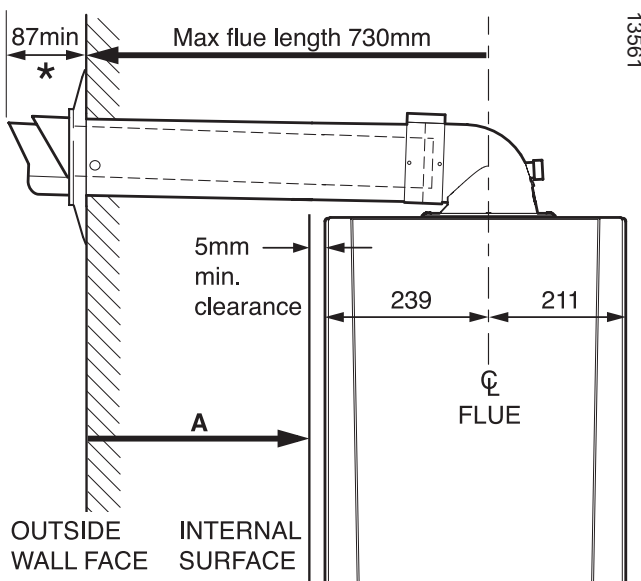

13561

A	
Max. distance from outside wall face to min clearance. LH - 486mm RH - 514mm	Min. distance from outside wall face to min clearance. LH/RH - 75mm

Diagram 10.10

10.6 Flue Length

The maximum permissible horizontal flue length is 10 metres plus the flue terminal assembly, this can be achieved by use of the accessories, see diagram 10.12.

However should additional 87.5° or 2 x 45° elbows be used then the length MUST be reduced by 1metre.

The diagram 10.10 shows the length achievable by using the kit A2043400.

When extension pipes are used the flue system must be designed to have a continuous fall to the boiler of at least 2.5° 44mm/metre to allow condensate to run back into the boiler and out via the condensate drain.

The flue can be installed from inside the building, when access to the outside wall face is not practicable.

Multiple Boiler Chimney Flue Length

The flue length must be calculated and installed according to the relevant standards EN 13384-1 and 2 (C43 flue systems only) with reference to the table below and the manufacturers instructions supplied.

The appliance maximum flue length must be included when calculating the overall design of the flue system.

NOTE: The horizontal flue terminal must be removed, see diagram 10.11.

MODEL	24cx	30cx
Exhaust mass rate (g/s)		
At Min Thermal Load (40C°/30°C)	2.30	2.36
At Max Thermal Load (80C°/60°C)	11.30	14.20
Exhaust temperature (°C)		
At Min Thermal Load (40C°/30°C)	56.0	63.0
At Max Thermal Load (80C°/60°C)	76.0	75.0

10 Standard Flue - Length, Preparation and Installation

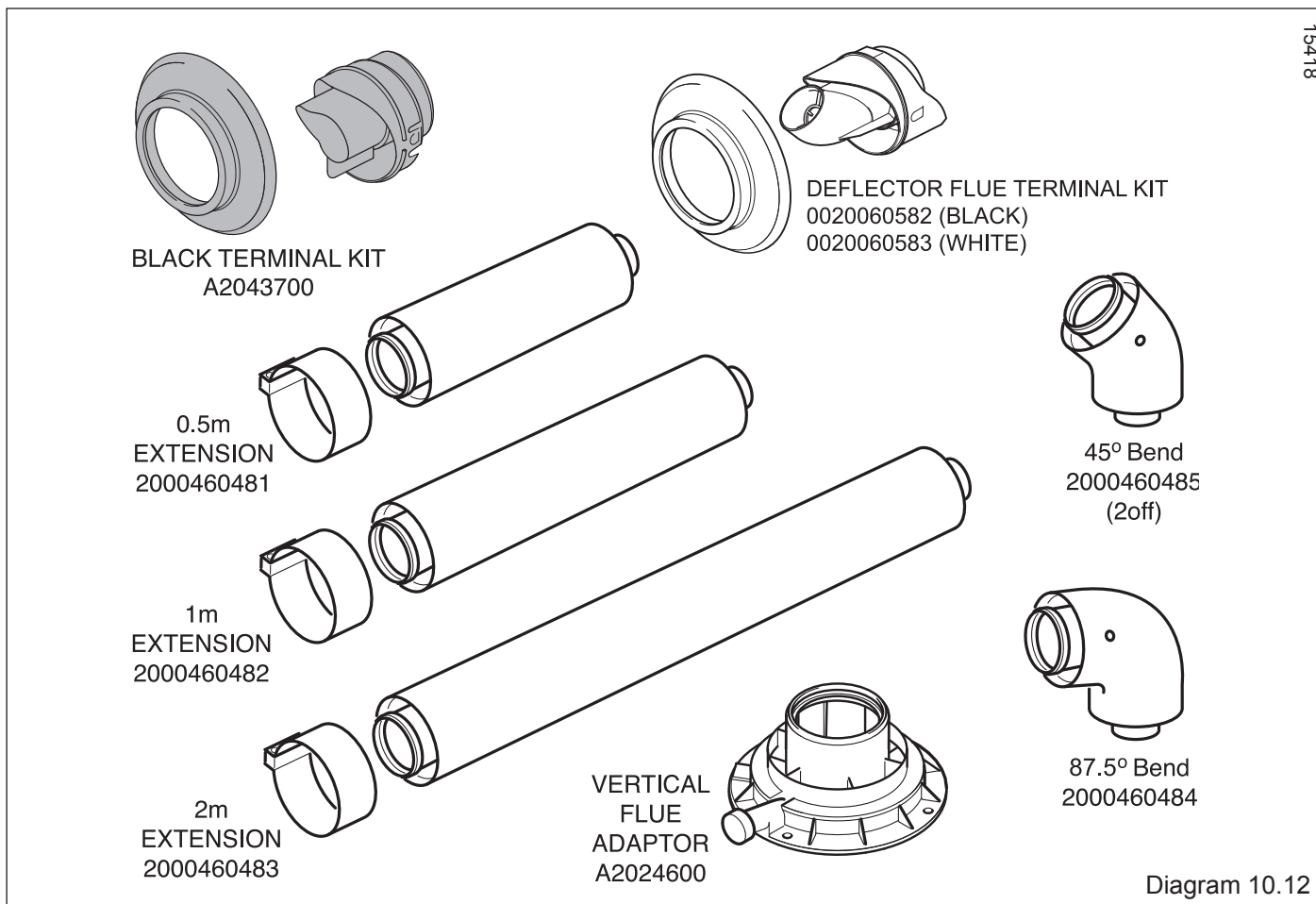
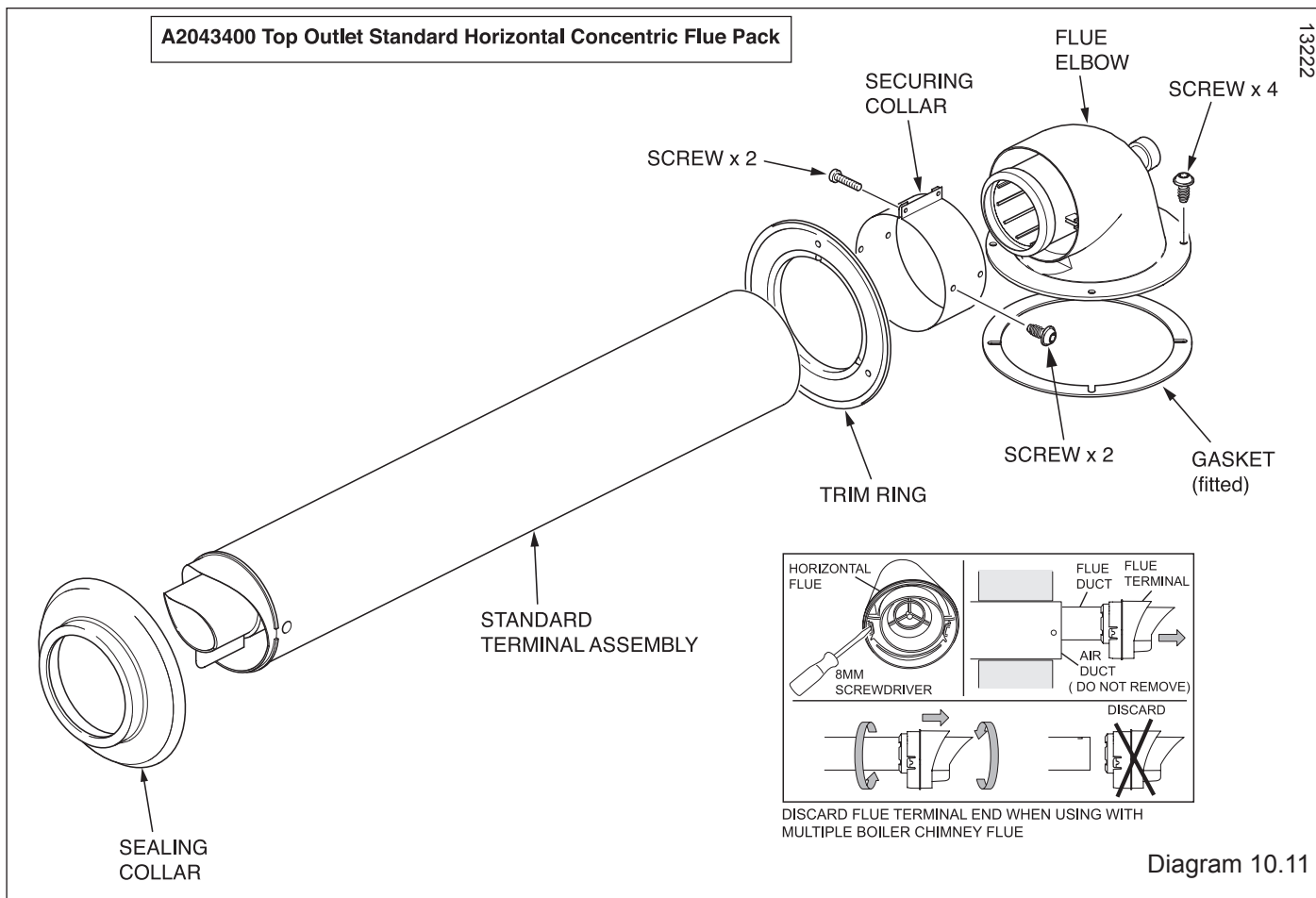

10 Standard Flue - Length, Preparation and Installation

10.7 Standard Horizontal Flue

Refer to diagram 10.11 for kit contents.

10.8 REAR Flue

With the flue elbow temporarily fitted, measure the distance from the outside wall to the butt joint, see diagram 10.13. If the measurement 'Y' exceeds 665mm, then the appropriate length of extension pipe is required. The minimum dimension is 187mm to suit a 75mm min wall thickness. The flue can project to a maximum of 600mm, refer to diagram 10.14.

10.9 SIDE Flue

With the flue elbow temporarily fitted, measure the distance from the outside wall to the butt joint, see diagram 10.15. If the measurement 'Y' exceeds 665mm, then the appropriate length of extension pipe is required. The minimum dimension for Lhd is 254 and Rhd 226 to suit a minimum wall thickness of 75mm. The flue can project to a maximum of 600mm, refer diagram 10.14.

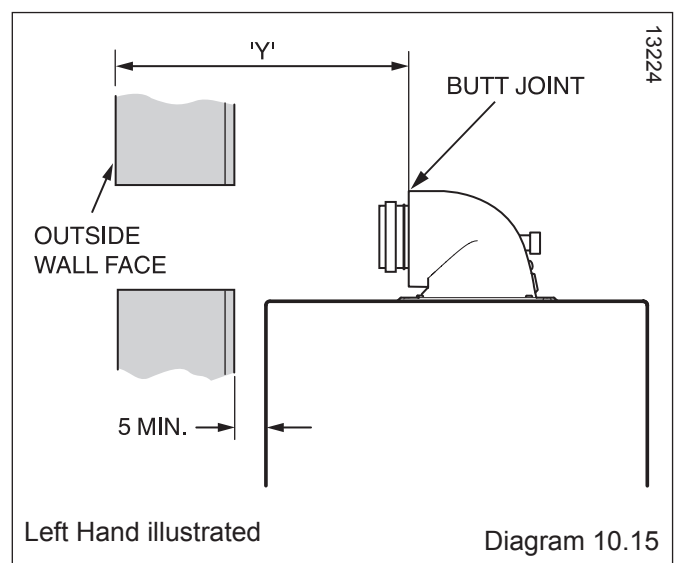
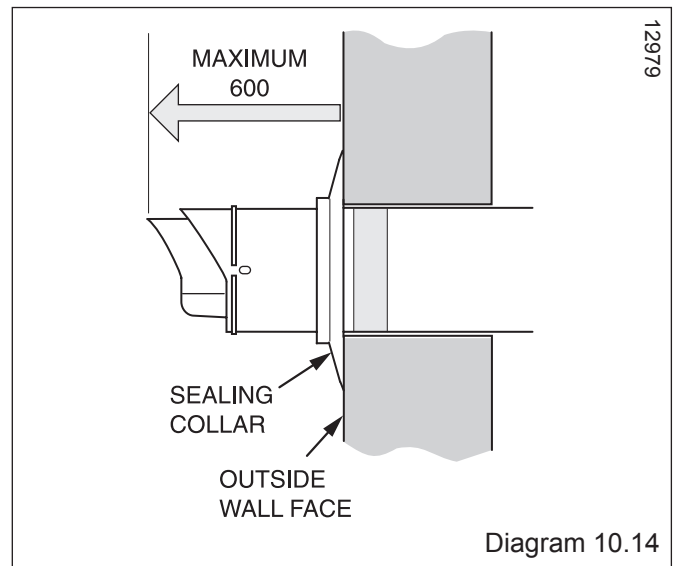
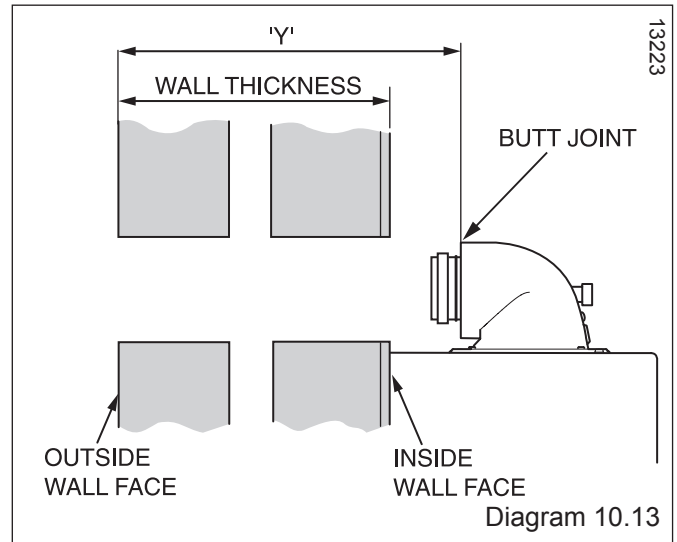

10 Standard Flue - Length, Preparation and Installation

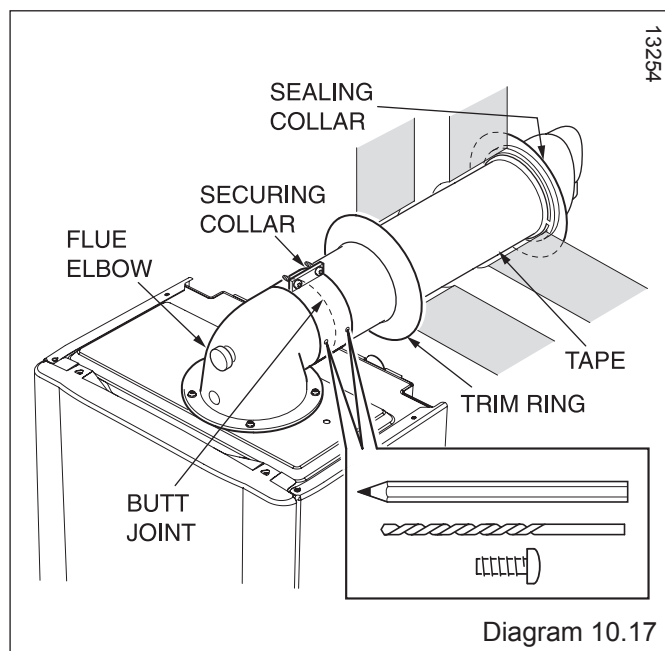
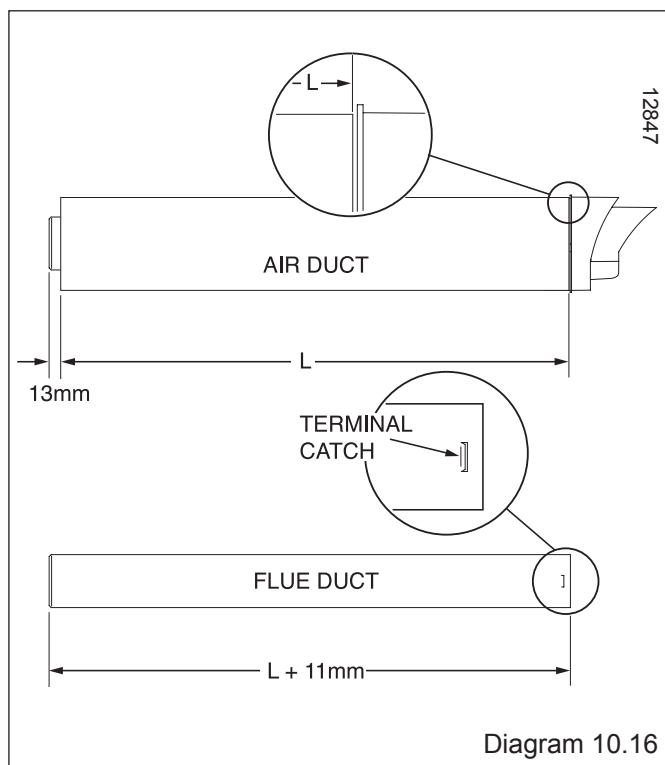

10.10 Flue Fitting

IMPORTANT:

The flue seals are sensitive to mineral oil based lubricants. **Do not grease the seals.** If the seals do need to be lubricated **use only water.**

During the installation of the flue system, ensure that debris such as mortar, filings or swarf are cleared from the flue system before completion.

Long lengths of flues must be secured to the walls or ceilings they run against. Use at least one clip for every flue extension that is used.

After cutting inner flue tubes ensure that you de-burr and chamfer the male tube end to prevent damage.

Inspect the flue pipes before fitting and do not install damaged or dented flue components.

When assembling the flue system, ensure that the inner seals are not damaged, do not install a flue component with a damaged seal.

When fitting flue elbows ensure that they are fitted at the correct angle to avoid strain, this will ensure that the seal fits correctly preventing leakage.

Remove the flue elbow.

Separate the flue duct from the terminal by twisting to release the terminal catch, then pull out of the retaining seal, refer to diagram 10.16.

The flue duct cutting length ($L + 11\text{mm}$.) is shown in diagram 10.16.

The air duct should be cut at the opposite end to the terminal

The plastic flue duct **MUST** be cut at the opposite end to the terminal catch.

The plastic flue duct extensions **MUST** be cut at the opposite end to seal.

Insert the flue duct into the air duct terminal assembly, remembering to engage the catch within the terminal.

Fit the sealing collar behind the locating lugs on the flue terminal, see diagram 10.17.

Push the flue assembly into the wall, externally or internally, initially until the end of the assembly protrudes a short way from the inside face of the wall. This will enable the internal trim ring (if required) to be positioned and allow the flue assembly to be drawn back into the flue elbow.

Secure the flue elbow in position on top of the boiler with four torque headed screws supplied.

Draw the flue assembly from wall and engage the flue duct into the elbow and butt fit between the air duct and flue elbow. Fit the securing collar into position.

Ensuring correct alignment of the flue, mark through two of the pre drilled holes in the securing collar.

Remove securing collar and drill two 3mm diameter holes one in the elbow and one in the air duct, take care not to pierce the inner flue duct. Fit the securing collar and secure with screws provided, see diagram 10.17.

Slide the internal trim ring back against the wall, securing in place with a small amount of sealant if required.

NOTE: If the air and flue ducts have been correctly cut to the instructions the sealing collar should fit flush with the outside wall.

10 Vertical Flue - Length, Preparation and Installation

10.11 Vertical flue

The vertical flue system is available as an option where the boiler position does not permit the use of the top horizontal flue system.

The system is made up from accessories. The accessories include terminal assembly, bends 45° and 87.5°, flue extensions, fixing bracket and appropriate weather collar, see diagram 10.19.

The maximum permitted straight flue length is 10 metres plus the terminal. for each 87.5° or 2x45° bends fitted, the maximum length must be reduced by 1 metre, see diagram 10.18.

NOTE: 2x45° bends can replace 1x87.5° bend if necessary. When using 87.5° bends any horizontal extension pipe should be inclined by a minimum of 44mm/metre (2.5°) towards the boiler to facilitate condensate removal, see (a) in diagram 10.18.

Alternatively use 45° bends to avoid horizontal runs, see (b) in diagram 10.18.

The terminal siting should be as shown in diagram 4.2.

Measure the distance of flue length required for the installation.

The flue must be designed with a continuous fall towards the boiler.

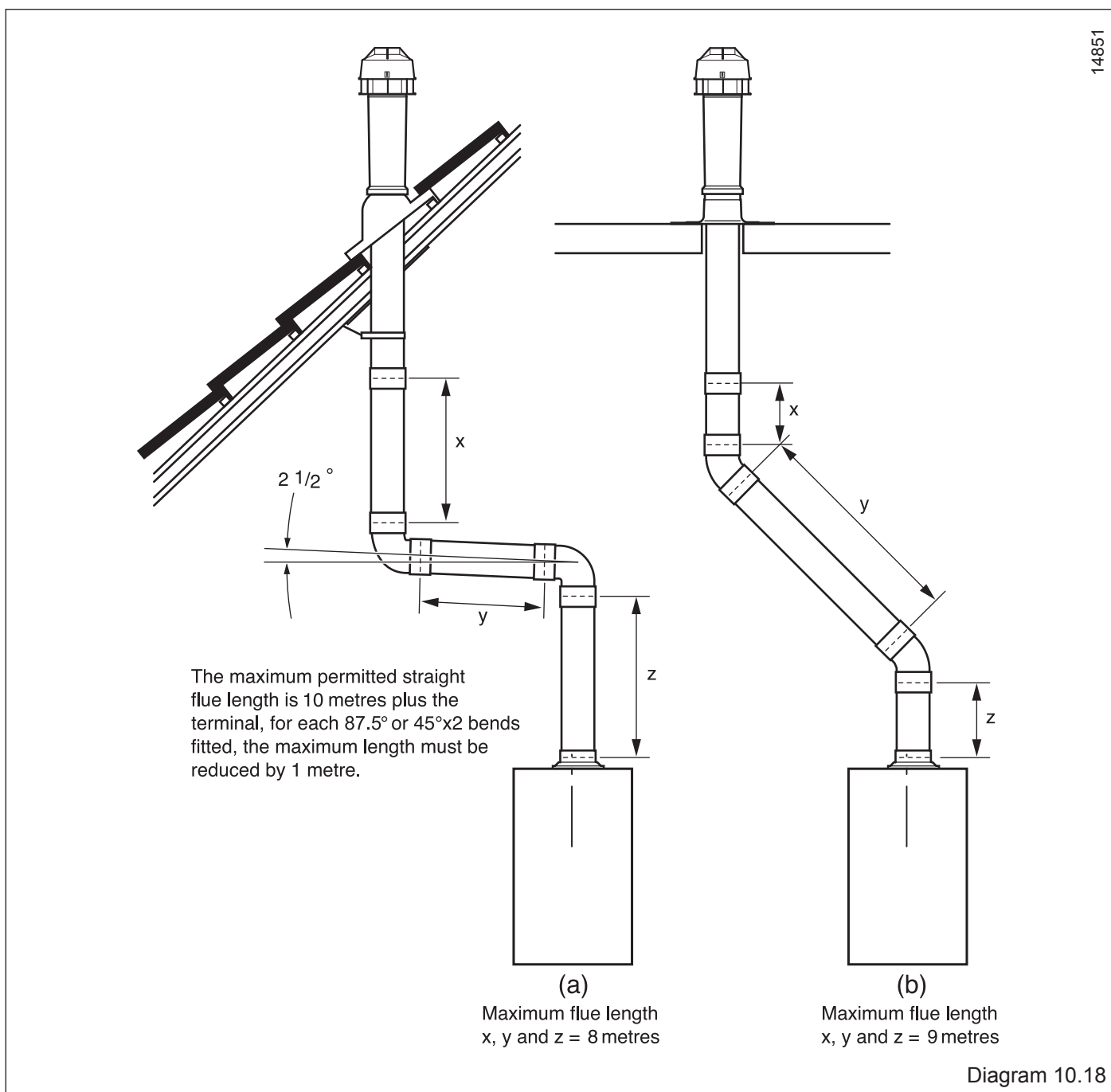

10 Vertical - Flue Length, Preparation and Installation

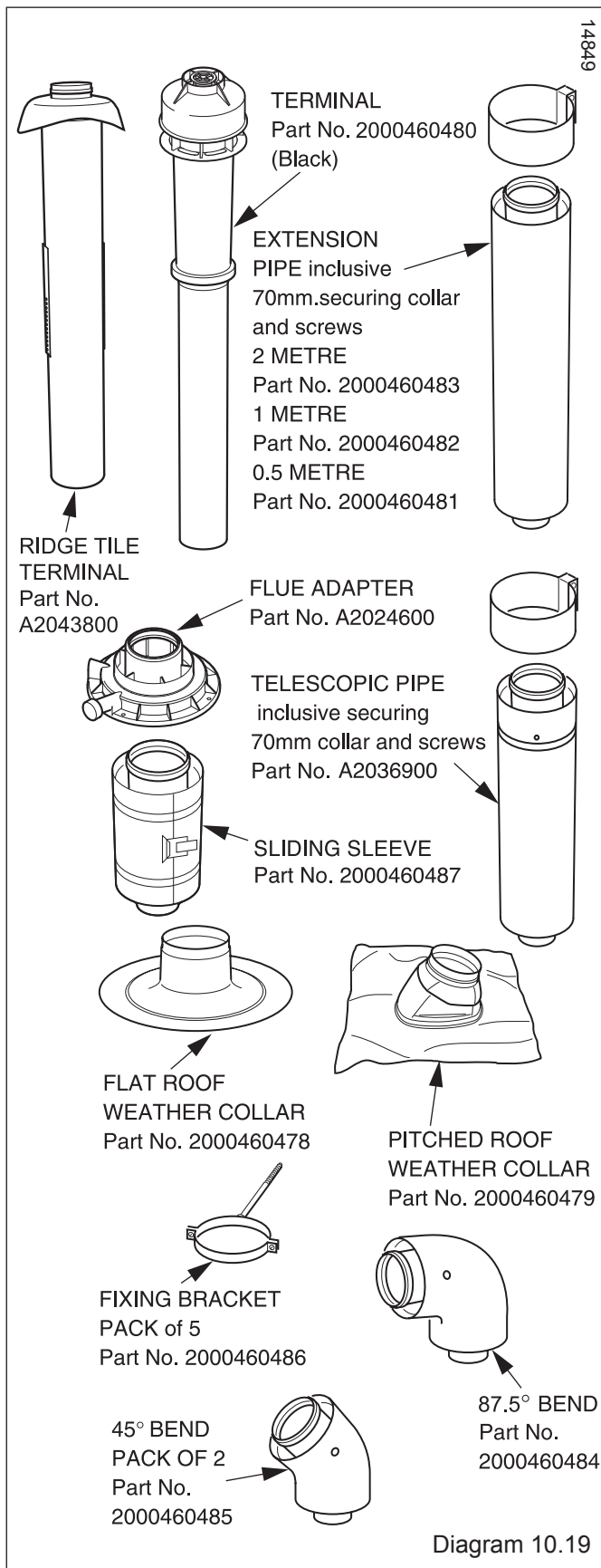

Flue Installation

IMPORTANT:

The flue seals are sensitive to mineral oil based lubricants. **Do not grease the seals.** If the seals do need to be lubricated **use only water.**

During the installation of the flue system, ensure that debris such as mortar, filings or swarf are cleared from the flue system before completion.

Long lengths of flues must be secured to the walls or ceilings they run against. Use at least one clip for every flue extension that is used.

After cutting inner flue tubes ensure that you de-burr and chamfer the male tube end to prevent damage.

Inspect the flue pipes before fitting and do not install damaged or dented flue components.

When assembling the flue system, ensure that the inner seals are not damaged, do not install a flue component with a damaged seal.

When fitting flue elbows ensure that they are fitted at the correct angle to avoid strain, this will ensure that the seal fits correctly preventing leakage.

Refer to diagram 10.21 and secure the flue adapter in position on top of the boiler with the four screws supplied, making sure the nib fits into the locating slot in the boiler casing to ensure correct orientation.

Secure the first extension pipe to the flue adapter with the securing collar supplied by positioning the collar centrally over the joint, then tighten the two screws on the securing collar, see diagram 10.22.

Fit more extension pipes as required using the collar and screws supplied with each extension pipe. To fit position the collar centrally over the joint, tighten the two screws on the securing collar. Using the holes provided in the securing collar drill and insert the two self tapping screws supplied, see diagram 10.23.

The rubber 'O' rings of each section should be lubricated prior to assembly.

Project the rise of the flue pipe to roof level and cut a 150mm hole in the roof.

Flue Terminal Installation

(a) Pitched Roof

Fit the required pitched roof weather collar over the 150mm hole in the roof. Make good the tiling or slating around the collar incorporating the flashing of the weather collar. Position the angle cap over the weather collar in the correct orientation to attain the correct angle for your roof.

(b) Flat Roof

Fit the aluminium weather collar over the 150mm hole in the roof ensuring a weather tight seal.

From above carefully place the flue terminal through the weather collar.

Flue Terminal to Boiler Connection

Should the clearances above the boiler to roof not allow for extensions, it is permitted to cut the flue terminal ensuring the relationship of flue and air duct lengths are retained.

10 Vertical Flue - Length, Preparation and Installation

Ridge Tile Terminal

A ridge tile terminal is available - part no. A2043800, see diagram 10.20.

The installation of a ridge tile will be required.

A suitable ridge tile is manufactured by: -

Aspect East Anglia Limited

The Old Mill

East Harling

NORWICH

NR16 2QW

Website: www.aspectroofing.co.uk

Contact: Chris Haythorpe

General Manager - Tile Division

Tel: 01953 717777 Fax: 01953 717164

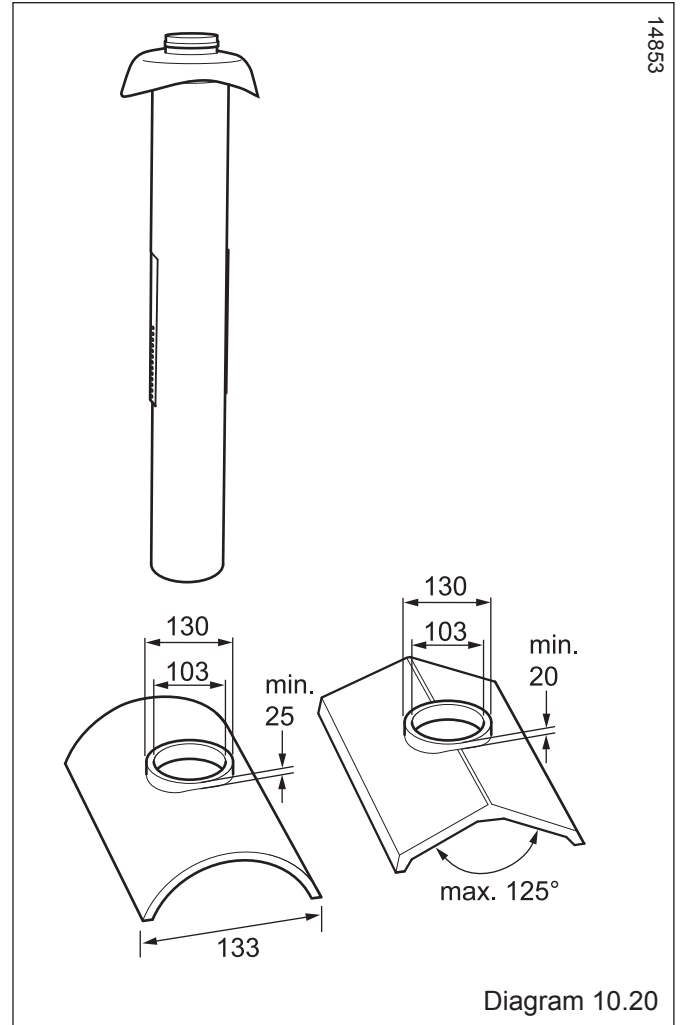

10 Vertical Flue - Length, Preparation and Installation

Completion of Installation

With the flue terminal positioned in the roof the length of the final pipe can be determined. If a telescopic length cannot be used, then a standard flue length can be cut to make the correct length. Cut the flue to the desired length measuring from the 'O' ring end and discard the plain end of the tube. The cuts must be square and made free of burrs to allow correct assembly.

NOTE: The flue pipe is 10mm longer than the air pipe, see diagram 10.24.

Carefully push the terminal assembly upwards to allow room for fitting the final flue piece. Fit a fixing bracket to the terminal assembly. Pull the terminal assembly down and join to the flue system. Ensure that the terminal is making a weather tight seal on the weather collar. Secure the fixing bracket fitted to the terminal to the roofing struts or a purpose made baton.

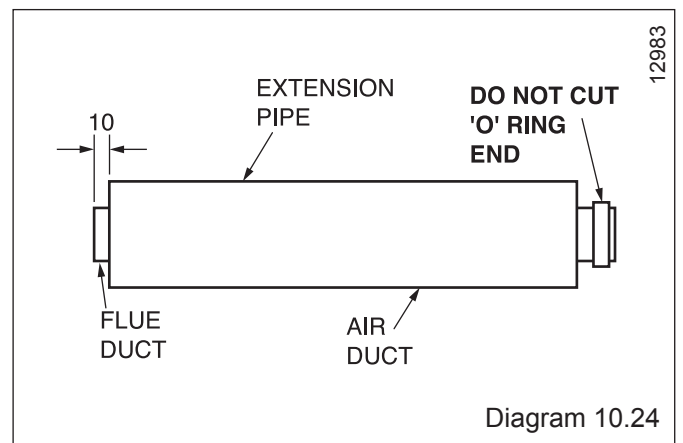
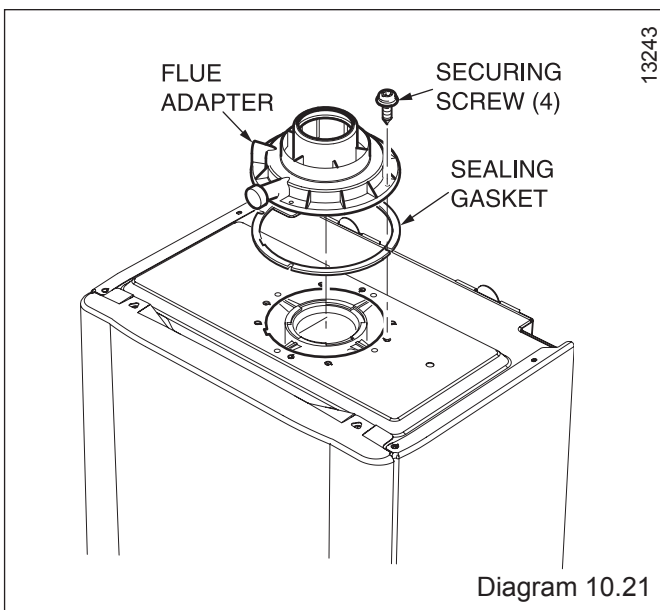
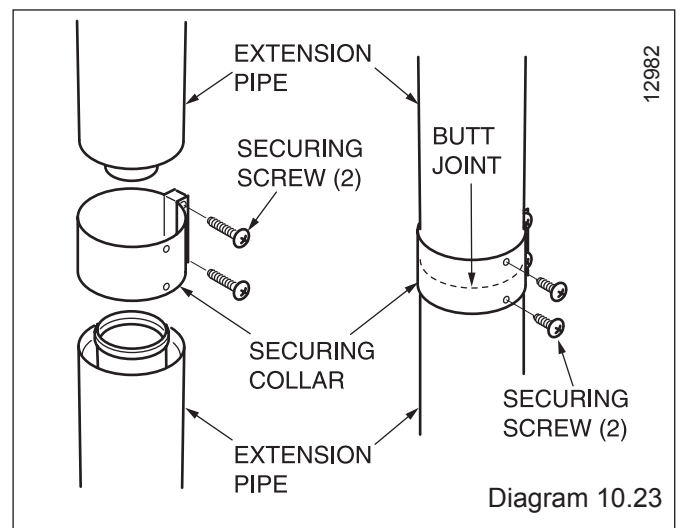
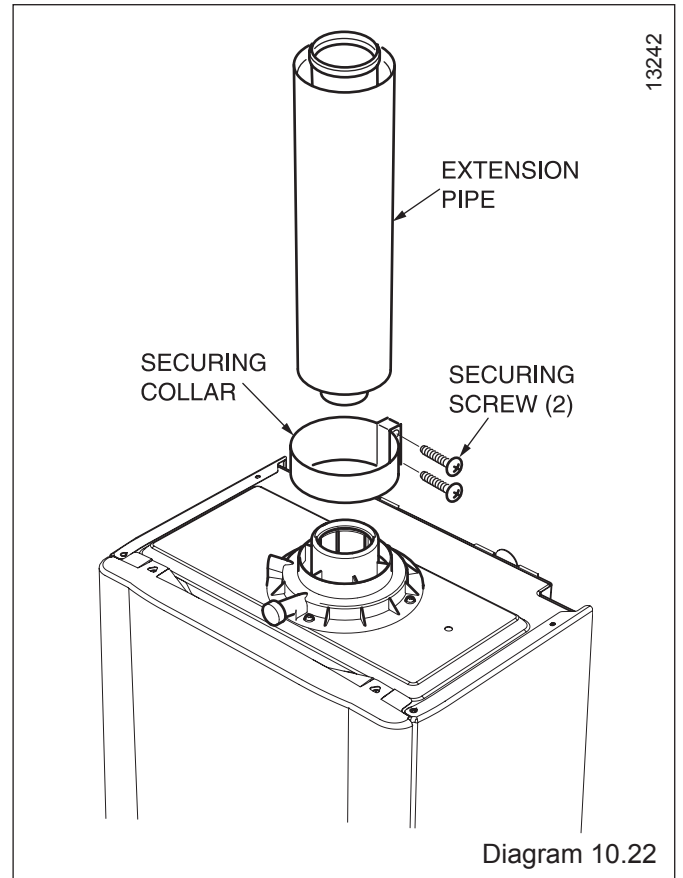

10 Twin Flue - Length, Preparation and Installation

15406

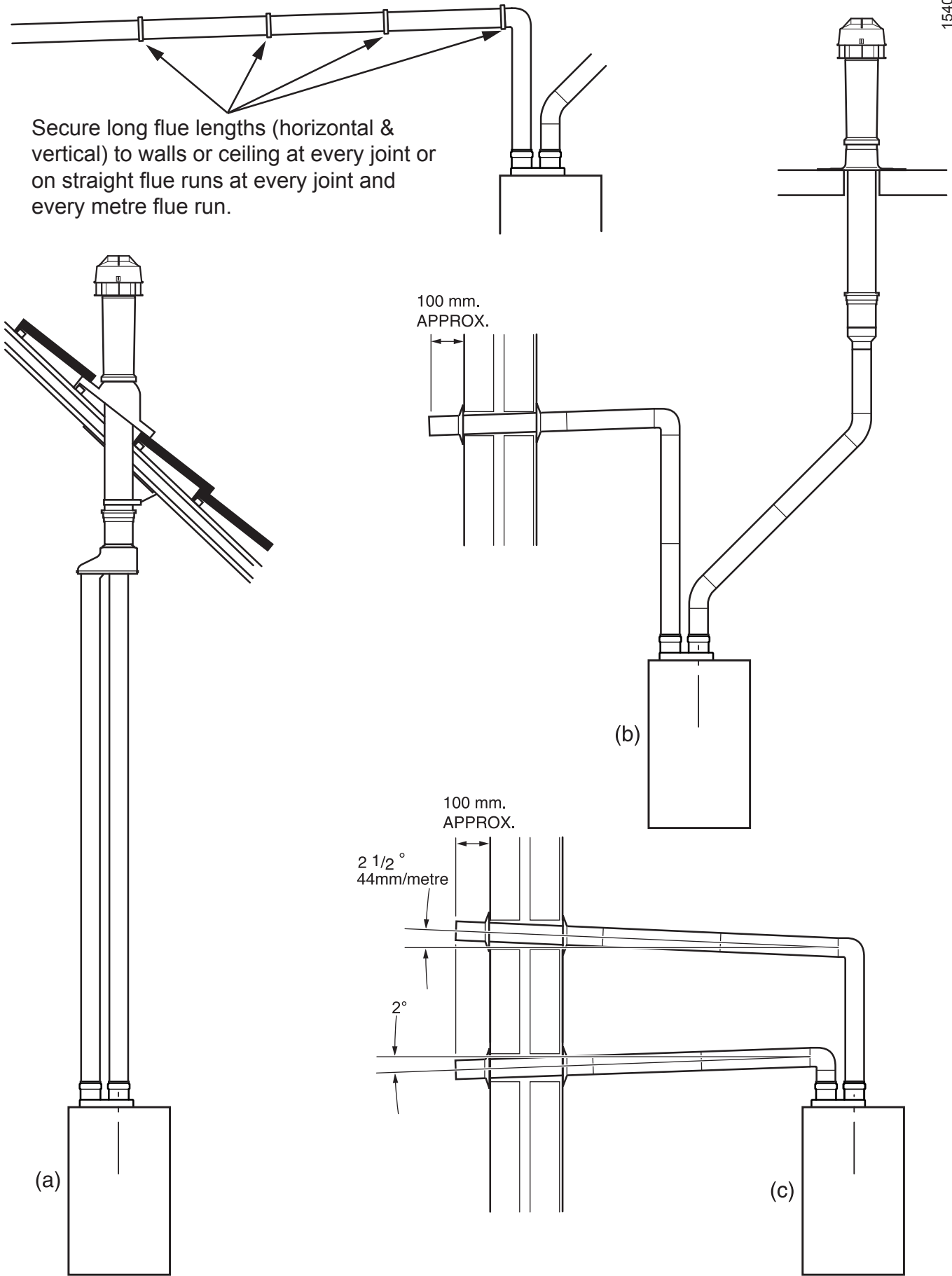

Diagram 10.25

10 Twin Flue - Length, Preparation and Installation

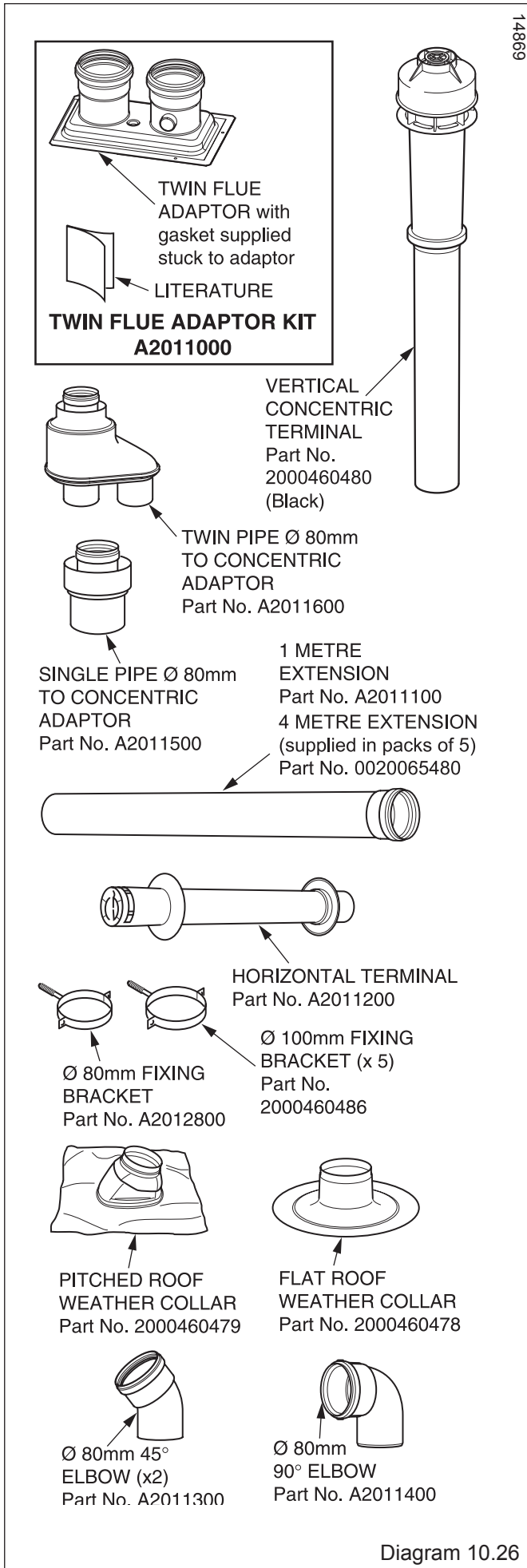

Diagram 10.26

10.12 Twin flue

The twin flue system is available as an option when the top horizontal or vertical flue system is not appropriate.

The system can provide an independent horizontal air inlet and flue outlet, horizontal air inlet and vertical flue outlet or vertical air inlet and flue outlet via a concentric terminal.

The system is made up from accessories, see diagram 10.26.

NOTE: The air and flue outlets do not have to be equal lengths. 2x45° bends can replace 1x90° bend if necessary.

The maximum permitted combined (air inlet + flue outlet) flue length is 40 metres plus terminal assemblies. For each 90° or 45° x 2 bends fitted, the maximum length must be reduced by 1 metre, see diagram 10.25.

NOTE: When using 90° bends any horizontal run should be inclined by a minimum of 44mm/metre (2.5°) towards the boiler to facilitate condense removal.

Alternatively use 45° bends to avoid horizontal runs in the flue pipe.

Multiple Boiler Chimney Flue Length

The flue length must be calculated and installed according to the relevant standards EN 13384-1 and 2 (C43 flue systems only) with reference to the table below and the manufacturers instructions supplied.

The appliance maximum flue length must be included when calculating the overall design of the flue system.

NOTE: The horizontal flue terminal must be removed.

Terminal Position

The clearances for a flue outlet are given in the "Flue Location and Ventilation" section.

In addition the horizontal air inlet must not be closer than 300 mm from a flue outlet on the same wall or 1200mm from an opposing flue outlet.

MODEL	24cx	30cx
Exhaust mass rate (g/s)		
At Min Thermal Load (40C°/30C°)	2.30	2.36
At Max Thermal Load (80C°/60C°)	11.30	14.20
Exhaust temperature (C°)		
At Min Thermal Load (40C°/30C°)	56.0	63.0
At Max Thermal Load (80C°/60C°)	76.0	75.0

10 Twin Flue - Length, Preparation and Installation

Installation Details

The parts available for a twin flue system installation are shown in diagram 10.26.

Boiler Connection

IMPORTANT: The flue seals are sensitive to mineral oil based lubricants. **Do not grease the seals.** If the seals do need to be lubricated **use only water.**

Place the twin flue adaptor onto the outlet of the boiler with the air inlet to the left hand side, see diagram 10.27. Secure the adaptor to the top panel with the screws provided. Care should be taken when inserting the screw through the hole in adaptor top.

To facilitate engagement, it is recommended that the rubber 'O' rings are lubricated with silicone grease or water prior to assembly.

Air and Flue Pipe Installation

The air and flue pipes can now be built up from the boiler.

The flue must be designed with a continuous fall towards the boiler. If using the horizontal flue pipe or 90° bends the pipe must be inclined at 44mm/metre (2.5°) minimum, see diagram 10.25.

Alternatively if space allows, use 45° bends in place of 90° bends.

To avoid rain ingress to the air Inlet terminal, it is good practice to aim the inlet downwards by approx 2° as rain can damage the boiler. The Flue outlet pipe must always run at 44mm/metre (2.5°) back to the boiler.

IMPORTANT:

Long lengths of flues must be secured to the wall or ceiling it runs against. Use at least one fixing bracket on each flue joint used or on straight flue runs every joint and for every metre flue run.

Provision must be made in concealed boxing or ductwork that the flue joints can be inspected during annual servicing.

The flue seals are sensitive to mineral oil based lubricants. **Do not grease the seals.** If the seals do need to be lubricated **use only water.**

Do not use the flue pipe to attach other pipes or equipment. If visible, advise the householder not to hang or clip items to flue pipes.

Do not stress the flue connections during the installation, this can damage the flue seals.

Horizontal Terminal Installation

NOTE: The air inlet terminal and the flue outlet terminals must never be installed on the opposite sides of a property. Termination must only be on the same wall or adjacent walls. When installed close together separated vertically, the air inlet must be fitted below the flue outlet terminal (see diagram 10.25).

The air terminal must not terminate less than 20mm from an adjacent wall or structure and the flue outlet terminal less than 100mm from any adjacent wall or structure.

With due consideration to terminal clearances mentioned in Section 4.2 drill the one or two holes as required with a 90mm core drill.

Push the horizontal terminal through the wall allowing approx. 100mm to protrude outside.

Push a grey rubber wall seal onto either side of the wall ensuring that both wall seals are pushed up to the wall surface, see examples (b) and (c) diagram 10.25.

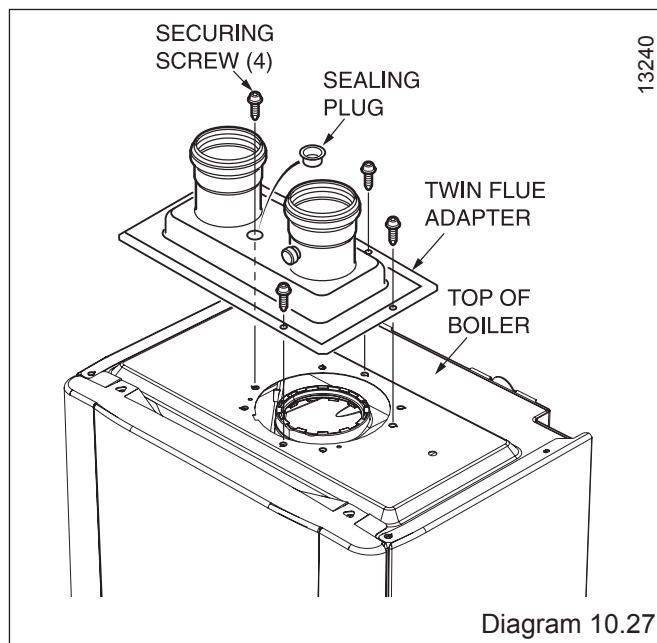

Diagram 10.27

Vertical Terminal Installation

With due consideration to terminal clearances mentioned in Section 4.2, project the rise of the flue pipe to roof level and cut 150mm hole in the roof.

(a) Pitched Roof

Fit the required pitched roof weather collar over the 150mm hole in the roof. Make good the tiling or slating around the collar incorporating the flashing of the weather collar. Position the angle cap over the weather collar in the correct orientation to attain the correct angle for your roof. One way round gives a pitch of 25°-38° and the other gives 37°-50°.

(b) Flat Roof

Fit the aluminium weather collar over the 150mm hole in the roof ensuring a weather tight seal.

Horizontal Pipes-Completion of Installation

Having built the pipe(s) from the boiler to the terminal(s), the length of the final pipe piece can be determined. Cut pipes at the opposite end to the 'O' ring seal making square and free from burrs. Push the horizontal terminal through the wall to engage the final pipe piece and pull back ensuring the grey wall seals are fully pulled up to the outside and inside wall faces.

Vertical Pipes-Completion of Installation

Refer to diagram 10.25.

For installation of (a), attach the twin pipe to concentric flue adaptor, part number A2011600, to the base of vertical terminal assembly. For installation of (b), attach the single pipe to concentric adaptor, part number A2011500, to the base of vertical terminal assembly.

With the vertical terminal assembly positioned in the roof, the length of the final pipe can be determined. Cut the flue to the desired length measuring from the 'O' ring seal end and discard the plain end of the tube. The cut end should be square and free from burrs. Carefully push the terminal assembly upwards to allow room for fitting the final flue piece(s). Fit a 100mm fixing bracket to the terminal assembly Part No2000460486. Pull the terminal assembly down and join to the flue system. Ensure that the terminal is making a weather tight seal on the weather collar. Secure the fixing bracket fitted to the terminal to the roofing struts or a purpose made baton.

10 Plume Management Kit

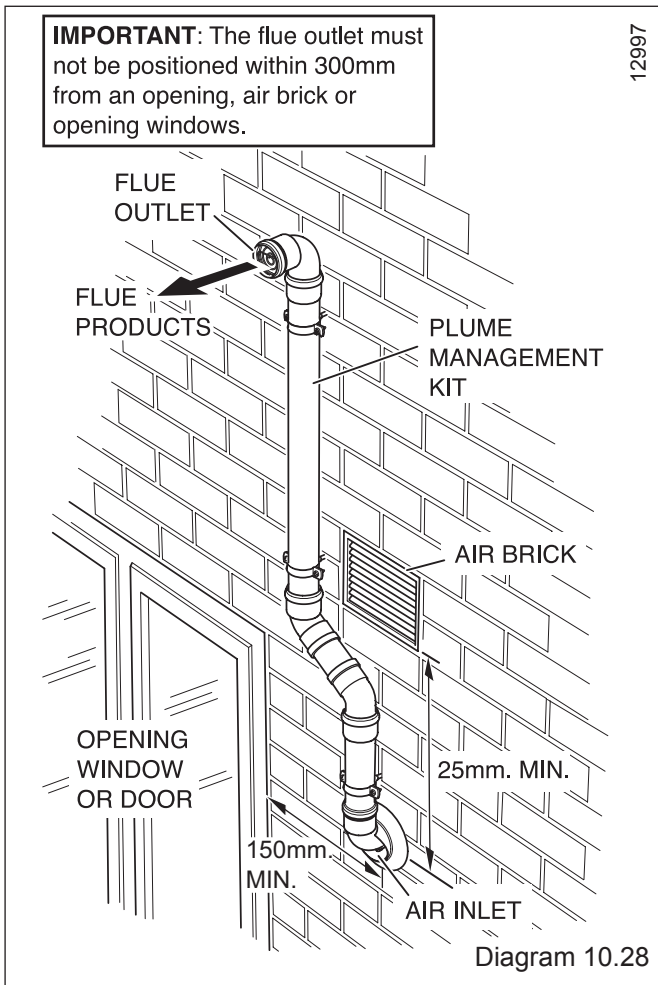

10.13 Plume Management Kit

The Plume Management Kit: Part No. A2044100 (white) or A2044000 (black) can be used to overcome many site issues.

The Plume Management Kit will fit to the Top Horizontal Telescopic, Rear Horizontal Telescopic and Standard Horizontal Flue. This enables the flue products to exhaust further away from the boiler, thereby reducing the impact of pluming.

NOTE: The flue air inlet can be sited closer to doors, opening windows and air bricks, than stated in section 4.2, see diagram 10.28.

The maximum length of the Plume Management Kit must NOT exceed 6m with a horizontal concentric flue length of 2m max.

For each 90° bend or 2 x 45° bends the maximum length of the Plume Management Kit must be reduced by 1m.

For more information contact Glow-worm, refer to page 2.

The Plume Management Kit is supplied with installation instructions.

Refer to BS5546 or BS6798 for advice on disposal of boiler condensate.

10 Deflector Flue Terminal Kit

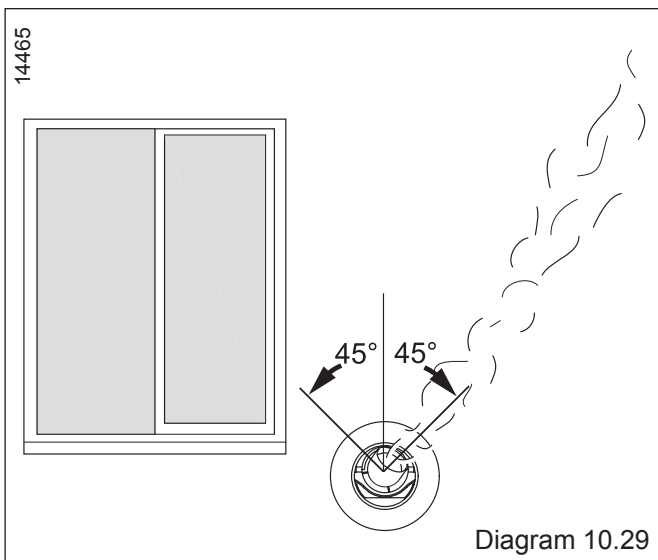

10.14 Deflector Flue Terminal Kit

The terminal kit fits onto the telescopic and standard horizontal flue, see diagram 4.1 for kit contents.

The kit is also supplied with installation instructions.

NOTE: The deflector flue terminal kit can be fitted after the boiler and flue have been installed.

The deflector part of the deflector flue terminal can be rotated 45° to allow pluming away from openings, people, cars, windows etc., see diagram 10.29.

Should the deflector terminal be positioned under a soffit or horizontal surface, it is allowed to project the flue 600mm from the wall, to allow the discharge of flue gases produced into free air.

IMPORTANT: Do not fit the deflector flue terminal with the deflector positioned downwards.

11 Electrical Connection

WARNING: This appliance must be earthed.

- This appliance must be wired in accordance with these instructions. Any fault arising from incorrect wiring cannot be put right under the terms of the Glow-worm guarantee.
- All system components must be of an approved type. Electrical components have been tested to meet the equivalent requirements of the BEAB.
- Do not interrupt the mains supply with a time switch or programmer.
- Connection of the whole electrical system and any heating system controls to the electrical supply must be through a common isolator.
- Isolation should preferably be by a double pole switched fused spur box having a minimum contact separation of 3mm on each pole. The fused spur box should be readily accessible and preferably adjacent to the boiler. It should be identified as to its use.
- A fused three pin plug and shuttered socket outlet may be used instead of a fused spur box provided that it is not used in a room containing a fixed bath or shower.
- The boiler is suitable for installation in bathroom zones 2 and 3

11.1 Electrical Wiring

Remove the electrical cartridge from the fittings pack.

Remove the securing screw to open the cartridge, see diagram 11.1.

NOTE: There are two screws supplied loose in the electrical cartridge, these will be required to secure the cartridge into the electrical interface housing.

Slacken the screws of the cable strain relief in the electrical cartridge, see diagram 11.1.

Route the mains supply and system cables through the strain relief and connect to the relevant plug, refer to the appropriate sections 11.2 or 11.3 .

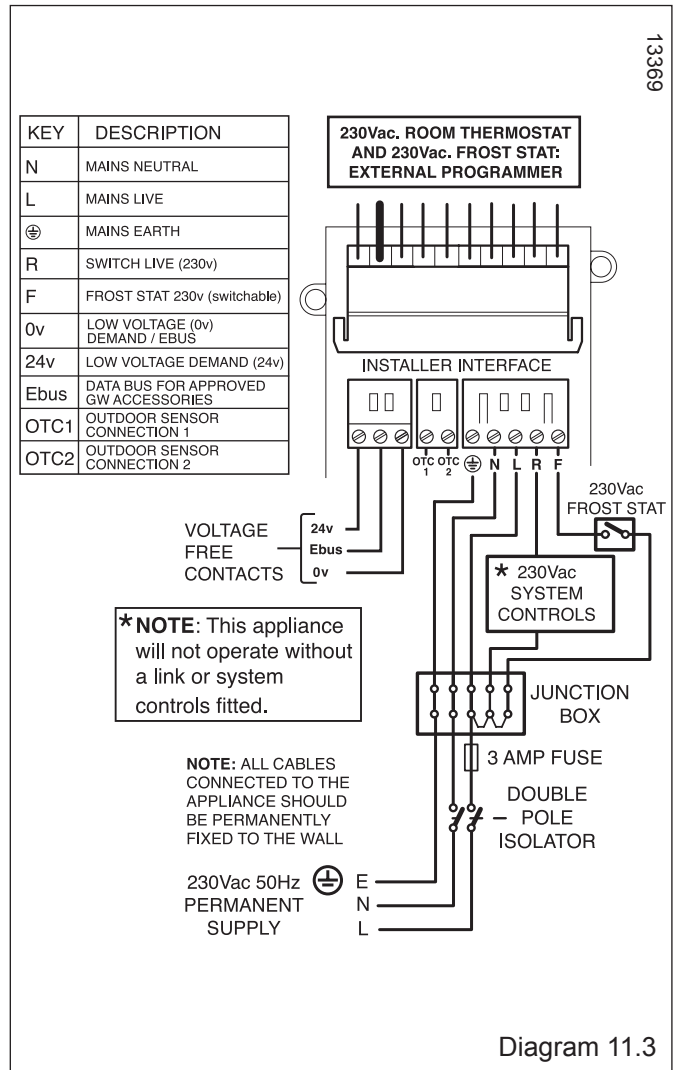
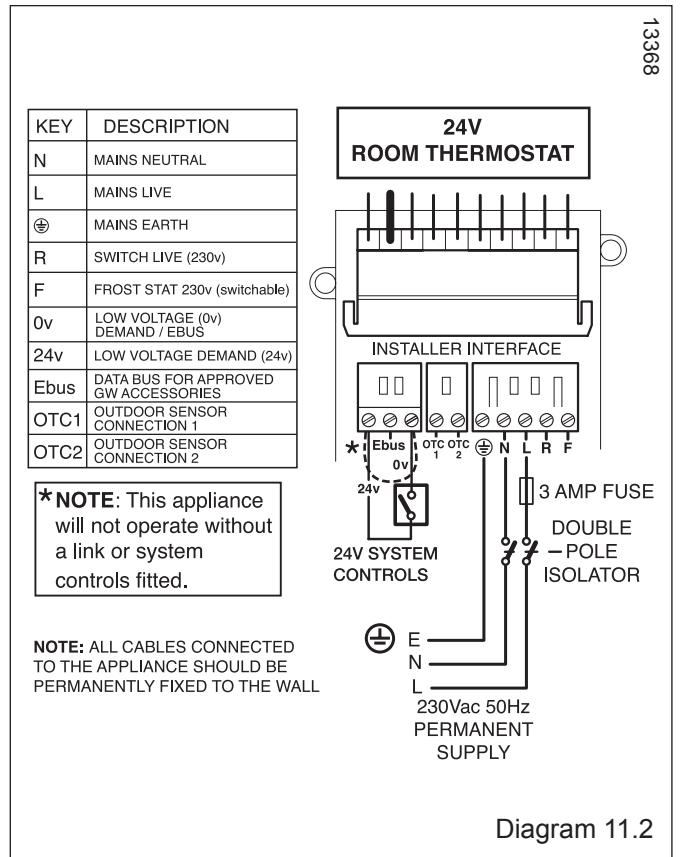
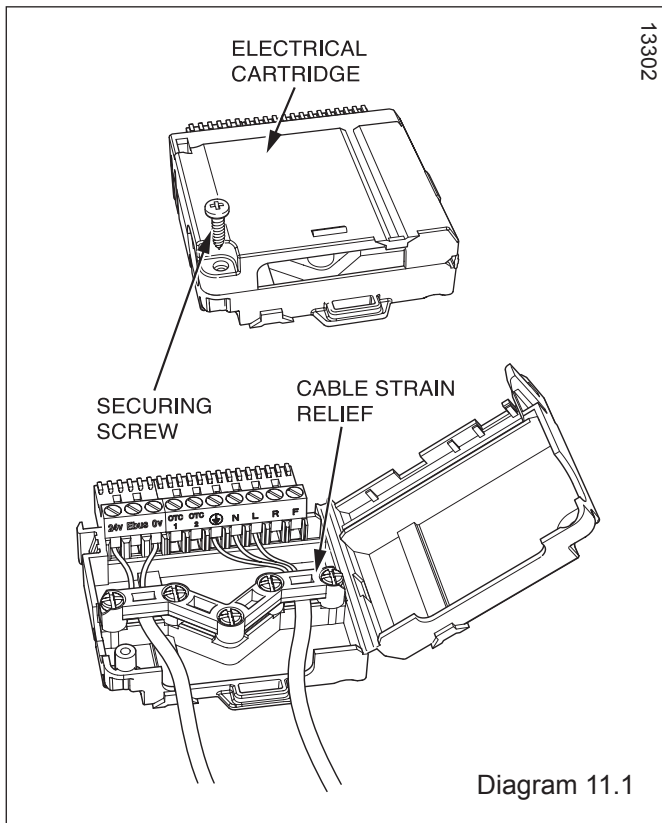

11 Electrical Connection

11.2 System Controls 24V

WARNING: UNDER NO CIRCUMSTANCES MUST ANY MAINS VOLTAGE BE APPLIED TO ANY OF THE TERMINALS ON THE 24V CONNECTION PLUG.

Connect the mains supply and system heating controls e.g. room thermostat as diagram 11.2. External controls should be fitted in accordance with the rules in force.

11.3 Mains Voltage System Controls

WARNING: UNDER NO CIRCUMSTANCES MUST ANY MAINS VOLTAGE BE APPLIED TO ANY OF THE TERMINALS ON THE 24V CONNECTION PLUG.

Connect mains supply and system controls as diagram 11.3. External controls should be fitted in accordance with the rules in force.

11.4 Electrical Cartridge Securing

Fit electrical cartridge into the interface housing on completion of the wiring, see diagram 11.4.

Secure with the two cartridge retaining screws provided in the cartridge body.

11.5 Electrical Connections - Testing

Carry out preliminary electrical system checks as below:

1. Test insulation resistance to earth of mains cables.
2. Test the earth continuity and short circuit of cables.
3. Test the polarity of the mains.

NOTE: If you require to test the appliance refer to section 14.

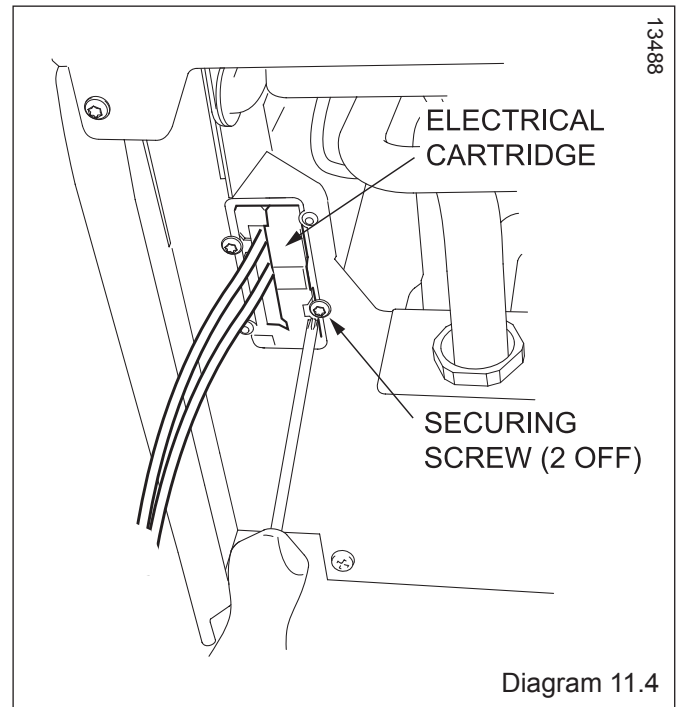

12 Commissioning

IMPORTANT: At the time of commissioning, complete all relevant sections of the Benchmark Checklist located in the centre pages of this document.

12.1 Preliminaries - All Systems

Do Not operate the boiler without water.

The commissioning should be carried out by a **competent person** approved at the time by the Health and Safety Executive and in accordance with the current issue of BS6798.

Make sure that the system has been thoroughly flushed out with cold water and that all cleanser if used has been removed.

With the gas service isolation valve closed, with no demand from any external controls and the power supply to the boiler switched off.

Test for gas soundness and purge air from the gas supply.

12.2 Filling the Heating Circuit

Switch on the power supply to the boiler.

The boiler should be in "OFF" mode, this will be indicated on the user interface display, refer to diagram 12.1. If not, press the "Mode" button repeatedly until the "OFF" symbol is displayed, then continue as follows:

1. Connect the flexible hose to the double check valve and secure by tightening the knurled nut marked 'A', refer diagram 12.2.
2. Open the Central Heating Flow and Return isolation valves marked 'B' using a screwdriver or a 4mm allen key - slot in line with the axis of the isolation valve (shown closed in diagram).
3. Ensure ALL cold water taps are shut off then open the Domestic Cold Water isolation valve marked 'C' using a screwdriver or a 3mm allen key - slot in line with the axis of the isolation valve (shown closed in diagram).
4. Open the tap 'D', then gradually open tap 'E' through 90° to fill the heating system to a pressure of 1.0bar then close the two filling taps.
5. Vent all air from the system - repeat step 4 as necessary until the system is full and all the air has been vented.
6. To comply with the water regulations the flexible hose

must be disconnected from the double check valve close the taps 'E' and 'D' then undo the knurled nut marked 'A' and pull the flexible hose from the double check valve.

12.3 Domestic Water Circuit

Check that water flows from the hot water taps.

Check for water tightness of the complete domestic water system.

The domestic hot water flow has a factory fitted restrictor, which reduces the flow to a maximum of, 8.0 l/min for 24cx, 12.0 l/min for 30cx.

Commissioning should only be carried out by a **competent person** approved at the time by the Health and Safety Executive.

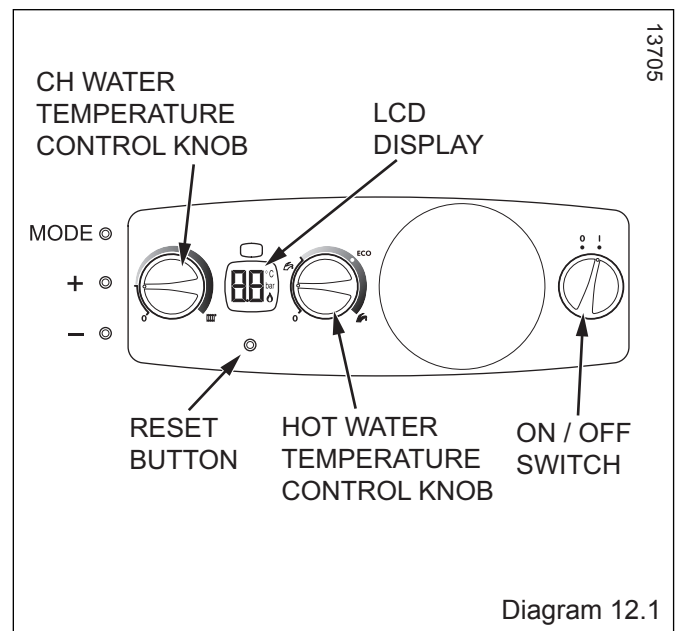

Diagram 12.1

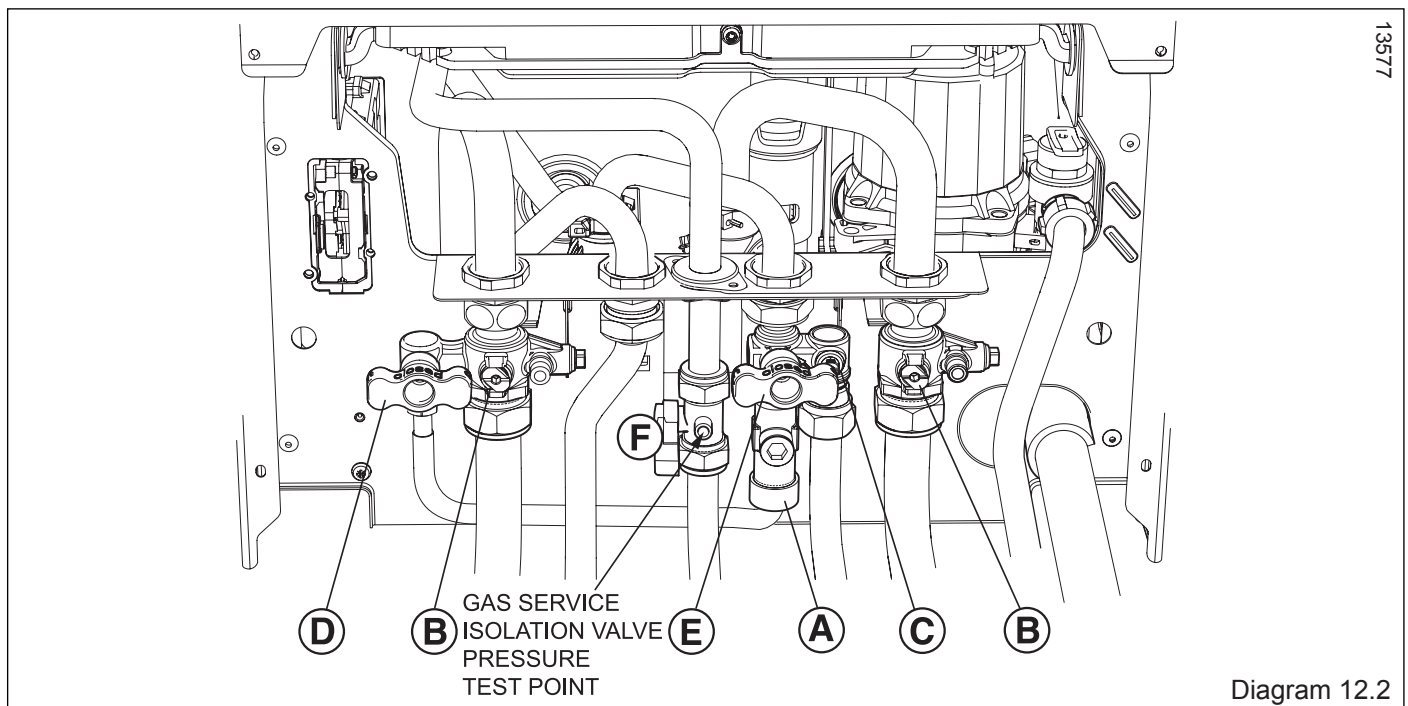

Diagram 12.2

12 Commissioning

Commissioning should only be carried out by a **competent person** approved at the time by the Health and Safety Executive.

12.4 Initial Lighting

NOTE: The combustion for this appliance has been checked, adjusted and preset at the factory for operation on natural gas (G20) as defined on the appliance data label.

No measurement of the combustion is necessary.

Having checked :

- the appliance has been installed in accordance with the instructions.
- the integrity of the flue system and flue seals.
- the integrity of the appliance combustion circuit and relevant seals.
- check that all external controls are calling for heat. If the integral programmer is fitted check that it is correctly programmed and if necessary overridden to provide heat.
- the gas service isolation valve 'F', diagram 12.2, is open.

LPG Conversion: See section 12.9.

The lighting procedure of the boiler is fully automated.

Ensure that both the central heating water temperature and the hot water temperature control knobs are turned OFF (0).

Ensure the mains electrical supply and turn the mains reset knob to (I) on the controls fascia.

Turn the central heating water temperature control knob to **MINIMUM**.

The digital display will show water temperature in central heating demand.

The fan should start and after a few seconds the ignition will commence

If the burner fails to light the fan will stop. Initially this may be due to air in the gas supply line. The boiler will automatically have five attempts at ignition.

If necessary press the reset switch and the boiler will restart.

After the boiler has lit, allow to warm at **MINIMUM** temperature setting to purge any air from the system.

NOTE: If the appliance is operated above **MINIMUM** on initial lighting, there is a possibility that the overheat lockout and "F5" will be displayed on controls fascia, this is due to air not having been completely purged. See diagram 12.1 for reset button.

Once the system has been purged of air turn the Hot water temperature control knob to the desired position and open a hot water tap. The diverter valve motor will move to hot water supply and the display will read system pressure. Check that hot water is available and then close the hot water tap.

Turn the Central heating water temperature control knob to the desired temperature.

The appliance will then continue to fire in central heating until the user controls are satisfied or there is another demand made for hot water.

12.5 Check the Gas Inlet Pressure and Gas Rate

Check the supply pressure at the gas service isolation valve test point, see diagram 12.2.

The nominal supply pressure should be 20mbar (8in wg) when the appliance is operating at the maximum heat input. This can be achieved by turning on several hot water taps.

NOTE: There is a pressure drop over the gas service isolation valve prior to the inlet pressure test point, this is normal and the inlet pressure to the main gas valve can be up to 2mbar less than the supply pressure to the boiler at the maximum heat input. Additionally the safe nominal maximum heat input of the appliance can be achieved at an inlet pressure down to 15mbar.

The gas valve is factory set for natural gas (G20) and should need no adjustment.

Should any doubt exist about the gas rate, check it using the gas meter test dial and stop watch, at least 10 minutes after the burner has lit, see table below, for approximate rates. Make sure that all other gas burning appliances and pilot lights are off.

It should be noted that the appliance will modulate the heat input according to demand. This may affect the gas rates measured if the appliance reaches its operating temperature during the measurement.

Turn taps off and disconnect the pressure gauge.

Operational Gas Inlet Pressure

With ALL other gas appliances operating, check the operational supply pressure at the gas service isolation valve test point, see diagram 12.2.

The nominal supply pressure for Natural Gas (G20) is 20mbar. The nominal supply pressure for LPG (G31) is 37mbar.

Turn the taps and appliances off, then disconnect the pressure gauge.

Additionally the safe nominal maximum heat input of the appliance can be achieved at an inlet pressure down to 15mbar.

NOTE: The **BURNER PRESSURE** cannot be measured and is not used to measure the gas rate.

Gas Rate

Make sure that ALL other gas burning appliances and pilot lights are off.

Check the gas rate using the gas meter test dial and stop watch, at least 10 minutes after the burner has lit, see table below for approximate rates.

GAS RATES (G20) (approx) after 10 mins from cold				
Model	MIN		MAX	
	m ³ /h	ft ³ /h	m ³ /h	ft ³ /h
24cx	0.48	16.8	2.24	79.0
30cx	0.48	16.8	2.80	99.0
GAS RATES (G31) (approx) after 10 mins from cold				
Model	MIN kg/hr		MAX kg/hr	
24cx	0.39		1.88	
30cx	0.39		2.34	

13659

In communal or LPG installations where the gas rate cannot be measured it is acceptable to measure the combustion rate as described in the servicing section. Reset the boiler.

12 Commissioning

12.6 Heating System

Check that all remote controls are calling for heat. The boiler will fire automatically. Fully open all radiator valves, flow control valve 'A', if fitted, see diagram 5.1.

Balance the radiators as required and if fitted adjust valve to give the required system differential. Turn off all radiators that can be shut off by the user and check to see if less than the maximum differential allowed of 20°C can be achieved across flow and return.

NOTE: Should the system require that the appliance has to be adjusted, the front casing will need to be removed as described in the servicing section 13 and the control box lowered into its service position.

The appliance pump has two speeds and can be adjusted depending on the requirements of the system.

The appliance has an inbuilt automatic adjustable bypass valve. The pressure can be adjusted between approx 1.5 and 3.5mH₂O but is factory pre-set to approx 2.5mH₂O. The pressure changes by approx 0.1mH₂O for each full turn of the bypass screw, see diagram 12.3. Turning clockwise increases the pressure and turning anti-clockwise decreases the pressure.

Allow the system to reach maximum temperature then switch off the boiler by isolating from the electrical supply.

Drain the entire system rapidly whilst hot, using the drain taps at all the low points of the system. Fill and vent the system as described previously in section 12.2.

Lock or remove the handle from control valve, if fitted.

Adjust the boiler temperature controls and any system controls to their required settings.

12.7 Completion

Fit the coverplate, see diagram 12.4.

Ensure that the magnetic lighting instruction label is placed on the surface of the boiler casing

GB: It is a requirement that the "Benchmark" Installation, Commissioning and Service Record is completed and left with the user.

IE: it is necessary to complete a "Declaration of Conformity" to indicate compliance to I.S.813. An example of this is given in the current edition of I.S.813.

12.8 Instruct the User

- Demonstrate, then instruct the User about the lighting procedure and heating system controls operation.
 - Advise that to ensure the continued efficient and safe operation of the boiler it is recommended that it is checked and serviced at regular intervals. The frequency of servicing will depend upon the installation conditions and usage, but in general, once a year should be enough.
 - Draw attention, if applicable, to the current issue of the Gas Safety (Installation and Use) Regulations, Section 35, which imposes a duty of care on all persons who let out any property containing a gas appliance in the UK.
 - The user shall not interfere with or adjust sealed components.
 - It is the Law that any servicing is carried out by a **competent person** approved at the time by the Health and Safety Executive.
 - Advise the user that, like all condensing boilers this appliance will produce a plume of condensation from the flue terminal in cool weather. This is due to the high efficiency and hence low flue gas temperature of the boiler.
 - Advise the user of the precautions necessary to prevent damage to the system, boiler and the building, in the event of the heating system being out of use during frost or freezing conditions.
 - Advise the user that the permanent mains electrical supply **SHOULD NOT** be switched off, as the built in frost protection and pump saver program will not operate.
 - Advise the User if the mains electricity and gas are to be turned off for any long periods during severe weather, it is recommended that the whole system, including the boiler, should be drained to avoid the risk of freezing.
- NOTE: Sealed System:** Contact your installation/servicing company as draining, refilling and pressurising **MUST** be carried out by a **competent person** approved at the time by the Health and Safety Executive.
- Leave these instructions and the 'Benchmark' Installation, Commissioning and Service Record with the user.

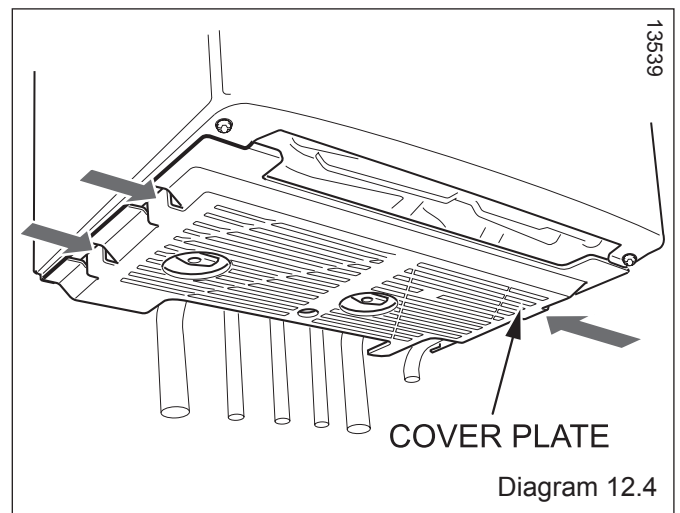
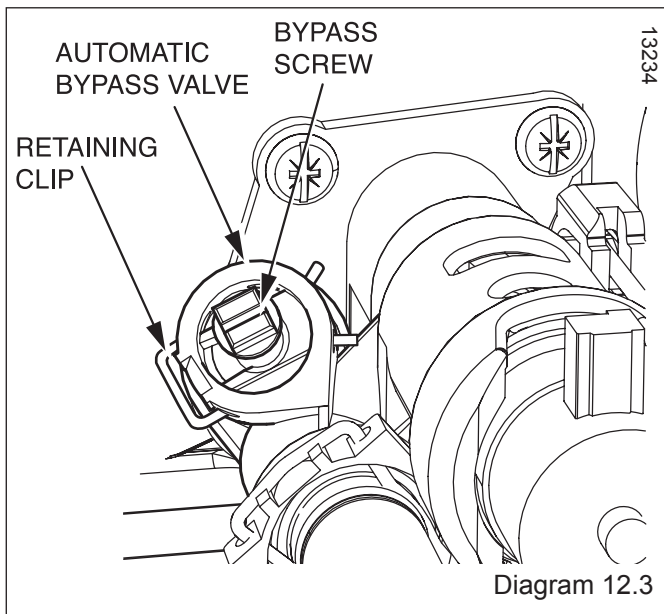

Natural Gas (G20) to LPG (G31) Conversion

12.9 LPG CONVERSION - all models

As an option, a chargeable boiler only commissioning service can be provided by Glow-worm Service by calling telephone No. 01773 828100.

NOTE: Steps 12.1 and 12.3 will need to be completed before the appliance can be converted.

This conversion should only be carried out by a **competent person** approved at the time by the Health and Safety Executive.

During the conversion to Propane use of a suitable flue gas analyser is necessary.

- The person carrying out a combustion measurement should have been assessed as competent in the use of a flue gas analyser and the interpretation of the results.

- The flue gas analyser used should be one meeting the requirements of BS7927 or BS-EN50379-3 and be calibrated in accordance with the analyser manufacturers' requirements.

- Competence can be demonstrated by satisfactory completion of the CPA1 ACS assessment, which covers the use of electronic portable combustion gas analysers in accordance with BS 7967, parts 1 to 4.

Tools required to make the conversion are a 2mm Allen key and an electrician's screwdriver.

Having checked :

- the appliance and system have been installed in accordance with the instructions.
- the integrity of the flue system and flue seals....
- the integrity of the appliance combustion circuit and relevant seals....
- that all internal/external controls are calling for heat.
- the gas service isolation valve 'F', diagram 12.2, is open

- (1) Access the gas valve.
- (2) Refer to diagram 12.5 and turn the gas valve throttle fully clockwise.
- (3) Turn the throttle anti-clockwise by the number of turns shown in the table.
- (4) Ensure that the gas analyser is set to the correct fuel setting - Propane.
- (5) Attach combustion analyser to the combustion test point, refer diagram 13.1.

IMPORTANT: Remember to replace the cap on completion of the test.

- (6) Turn on the mains electrical supply and turn on the gas service isolation valve. Switch the boiler on.
- (7) Generate a hot water demand by fully opening a hot water tap. The boiler should fire automatically.

NOTE: If the appliance does not light and goes to lockout (F1) turn the throttle anti-clockwise a further turn and press the reset button, see diagram 12.1. The appliance will (after a short delay) again attempt to fire. Repeat this procedure (up to a total of 2 extra turns on the throttle screw) until the appliance lights. PLEASE NOTE several ignition attempts may be needed, to purge gas through the appliance, before a successful ignition is achieved.

- (8) Check and adjust the burner %CO₂ at maximum rate.

Refer to diagram 12.1. Press the "reset" button on the controls fascia, release and immediately press and hold in the "+" button. After approximately 5 seconds "Hi" will be displayed. Pressing the mode button when "Hi" is selected will force the boiler to maximum rate, the display will flash between "Hi" and the "default display" this will indicate the boiler has been forced to maximum.

- (9) Adjust, if necessary, the burner % CO₂ to the value shown in the "SETTING" column of the table, with the throttle screw, see diagram 12.5 (rotate anti-clockwise to increase).

G31 BURNER % CO ₂				
MODEL	CHECK (case on)	SETTING (case off)	Throttle TURNS	CO/CO ₂
24cx	9.2 to 10.2	10.0 ^{+0.0} _{-0.9}	5 1/4	0.004
30cx	10.0 to 11.0	10.5 ^{+0.3} _{-0.7}	5 1/2	0.004

13874

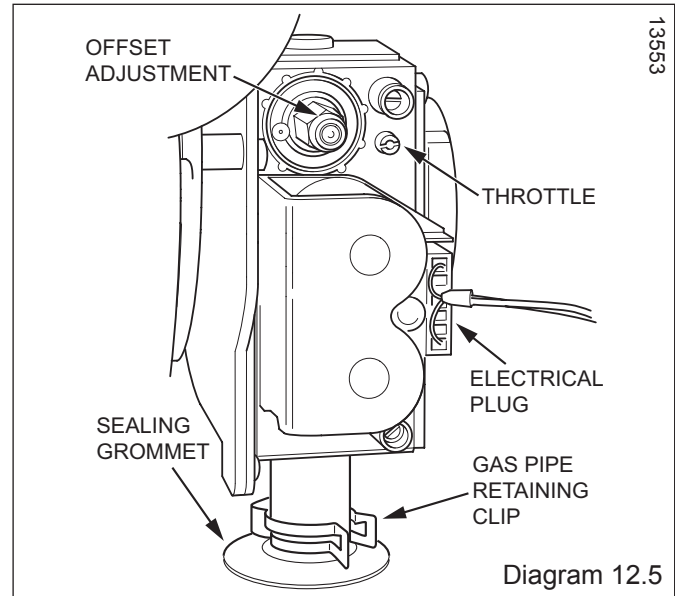

13853

- (10) To exit the check sequences press the "mode" and "+" buttons simultaneously, this will reset the boiler to the default display.
- (11) Check the burner % CO₂ , at minimum rate, to the value shown in the "SETTING" column of the table.
- (12) If adjustment is required, press the "reset" button on the controls fascia, release and immediately press and hold in the "+" button. After approximately 5 seconds "Hi" will be displayed. Pressing the "+" or "-" buttons will cycle between "Hi" and "Lo". Pressing the mode button when "Lo" is selected will force the boiler to minimum rate, the display will flash between "Lo" and the "default display" this will indicate the boiler has been forced to minimum.
- (13) Adjustment of the %CO₂ is very coarse so carefully adjust the %CO₂ to the value shown in the "SETTING" column of the table with the offset adjustment, see diagram 12.5 and %CO₂ Table (Rotate clockwise to increase).
- (14) To exit the function press the "mode" and "+" buttons simultaneously, this will reset the boiler to the default display.
- (15) Repeat (8) and check CO₂ at maximum rate - adjust if necessary. Check that the CO/CO₂ ratio is less than the value in the table above.
Please remember after finishing this procedure to turn off the hot water tap.
- (16) Remove analyser probe from the test point and replace the cap. Refit the control panel.
- (17) **IMPORTANT:** Fit the LPG conversion label supplied in the documentation pack to the inner front panel alongside the data label. Refit the inner door and outer door.
- (18) Continue commissioning from 12.5.

13 Servicing

IMPORTANT NOTES:

1. To ensure the continued efficient and safe operation of the boiler it is recommended that it is checked and serviced at regular intervals. The frequency of servicing will depend upon the particular installation and usage, but in general once a year should be enough.
2. It is the Law that any servicing is carried out by a **competent person** approved at the time by the Health and Safety Executive.
3. Before commencing with a service or replacement of parts the boiler should be isolated from the electrical supply and the gas supply should be turned off at the gas isolation valve.
4. When replacing a part on this appliance, use only spare parts that you can be assured conform to the safety and performance specification that we require. Do not use reconditioned or copy parts that have not been clearly authorised by Glow-worm.
5. If any electrical connections have been disconnected and after their connection, checks to the earth continuity, polarity, short circuit and resistance to earth must be repeated using a suitable multimeter, as described in section 14.
6. After servicing, complete the relevant Service Interval Record section of the Benchmark Checklist located in the centre pages of this document.

General Inspection

Prior to, during servicing and after any maintenance or changed parts, the following must be checked.

- The integrity of the flue system and flue seals.
 - The integrity of the appliance combustion circuit and relevant seals.
 - Electrical, gas and water connections.
 - System pressure.
 - the combustion performance, refer to the following procedure.
 - The operational gas inlet pressure and gas rates, refer to the commissioning section paragraph 12.5.
- Correct any fault before continuing.

COMPETENCY TO CARRY OUT THE CHECK OF COMBUSTION PERFORMANCE

NOTE: BS 6798: 2009 Specification for installation and maintenance of gas-fired boilers of rated input not exceeding 70kW net advises that:

- The person carrying out a combustion measurement must be assessed as competent in the use of a flue gas analyser and the interpretation of the results.
- The flue gas analyser used should be one meeting the requirements of BS7927 or BS-EN50379-3 and be calibrated in accordance with the analyser manufacturers' requirements.
- Competence can be demonstrated by satisfactory completion of the CPA1 ACS assessment, which covers the use of electronic portable combustion gas analysers in accordance with BS 7967, parts 1 to 4.
- Ensure that the gas analyser is set to the correct fuel setting.
- Turn both temperature control knobs on the fascia to maximum.

NOTE: Safe combustion can only be verified by measuring CO/CO₂ ratio. This must not exceed the value shown in the table opposite.

COMBUSTION CHECK AND SETTING THE AIR/GAS RATIO VALVE

- Remove the front casing panel, see diagram 13.2 and hinge down the control box. Taking care not to touch any internal components, proceed as follows:
- Connect the CO₂ combustion analyser to the relevant test point, see diagram 13.1.

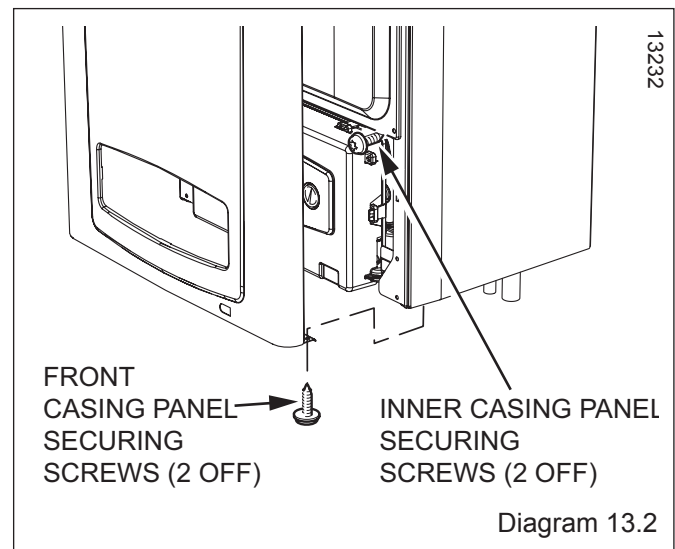
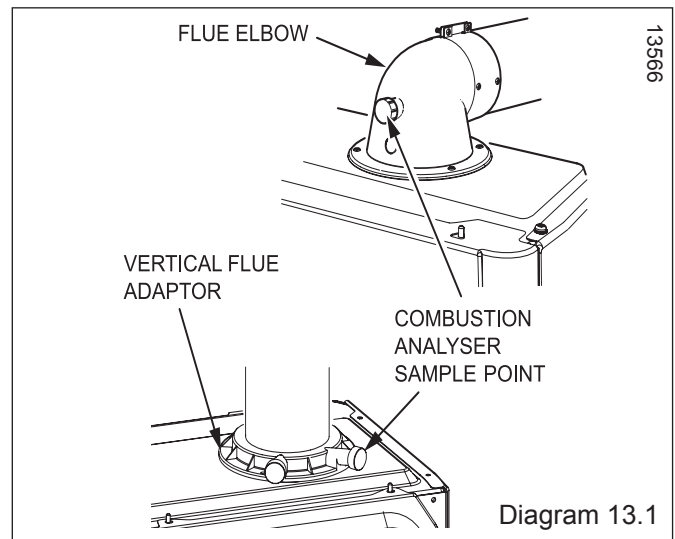

13 Servicing

1. Maximum Rate Check and Adjustment

NOTE: To verify the maximum gas rate CO₂ setting the appliance must be checked at the maximum rate first, refer to diagram 12.1. Press the “reset” button on the controls fascia, release and immediately press and hold in the “+” button. After approximately 5 seconds “Hi” will be displayed. Pressing the mode button when “Hi” is selected will force the boiler to maximum rate, the display will flash between “Hi” and the “default display” this will indicate the boiler has been forced to maximum. Wait until the CO₂ value is stable and check that the value is within the range specified in table in the “check” column.

If the combustion reading is not within the acceptable values AND the integrity of the complete flue system and combustion circuit seals have been verified and the inlet gas pressure (and gas rate) have been verified, then, it will necessary to adjust the combustion rate of the appliance.

NOTE: Adjustment is made by turning the gas valve throttle an 1/8 of a turn, waiting 1 minute to allow the appliance to stabilise before checking or making further adjustments.

- Rotate the “throttle”(anti-clockwise to increase), to the required CO₂, refer to diagram 12.5 and the “SETTING” column in the table.
- Exit the forced rate function, press the “mode” and “+” buttons simultaneously, this will reset the boiler to the default display. Now proceed to check the minimum rate adjustment.

2. Minimum Rate Check and Adjustment

• Now check the minimum gas rate CO₂ setting: Press and release the “reset” button on the controls fascia, then immediately press and hold in either of the “+” buttons. After approximately 5 seconds “Hi” will be displayed. Pressing the “+” or “-” buttons will toggle between “Hi” and “Lo”. Press the mode button when “Lo” is selected, this will force the boiler to minimum rate and the display will flash “Lo”, indicating the boiler is operating at minimum.

• Wait until the CO₂ value is stable and check that the value is within the range specified in table in the “check” column. If adjustment is necessary, proceed as follows:

NOTE: Adjustment of the CO₂ at minimum rate is very coarse and should not be adjusted more than an 1/8 of a turn at a time. Wait 1 minute to allow the appliance to stabilise before checking or making further adjustments.

- Gradually rotate the “offset adjustment” (anti-clockwise to decrease) to the required CO₂, refer to diagram 12.5 and the “SETTING” column in the table.
- Exit the minimum rate function, press the “mode” and “+” buttons simultaneously, this will reset the boiler to the default display.

3. Re-Check CO₂ and check the CO/CO₂ combustion ratio.

• Re-check the maximum and minimum CO₂ values to ensure that they are within the “setting” limits in the table then check the CO/CO₂ combustion ratio does not exceed the value in the CO/CO₂ column of the table. If the CO/CO₂ setting exceeds the value in the table, a complete servicing of the appliance will be necessary, refer to section 13.1. If the CO₂ and the CO/CO₂ ratio falls within the tolerances quoted, exit the function press the “mode” and “+” buttons simultaneously, this will reset the boiler to the default display. Remove the analyser probe and replace the cap on the sampling point, replace the controls fascia, inner and front casing panels.

IMPORTANT: Remember to replace the sample point cap on completion of the test.

GAS RATE CHECK

Check the gas rates as described in the commissioning section.

COMPLETION

If it is not possible to achieve the required results for either the combustion or gas rates, it will be necessary to complete a full service of the appliance and then repeat the combustion check procedure. If after servicing and adjustment of the appliance the combustion values are still unacceptable and after further remedial work has been carried out, the appliance must be disconnected until the CO/CO₂ ratio is acceptable. Advice can be sought from the Glow-worm Technical Helpline.

13.1 Servicing

NOTE: If the Combustion CO₂, CO/CO₂ ratio & Gas rate checks did not require adjustment then it will not be necessary to complete a full service.

All routine servicing requirements can be achieved by the removal of the front panel, see diagram 13.2. Position the control box into the service position, see diagram 13.3. Before commencing with a service or replacement of parts. The boiler should be isolated from the electrical and gas supplies.

G31 BURNER % CO ₂			
MODEL	CHECK (case on)	SETTING (case off)	CO/CO ₂ ratio
24cx	9.2 to 10.2	10.0 ^{+ 0.0} - 0.9	0.004
30cx	10.0 to 11.0	10.5 ^{+ 0.3} - 0.7	0.004
G20 BURNER % CO ₂			
MODEL	CHECK (case on)	SETTING (case off)	CO/CO ₂ ratio
24cx	8.5 to 9.6	9.1 ^{+ 0.2} - 0.5	0.004
30cx	8.5 to 9.6	9.1 ^{+ 0.2} - 0.5	0.004

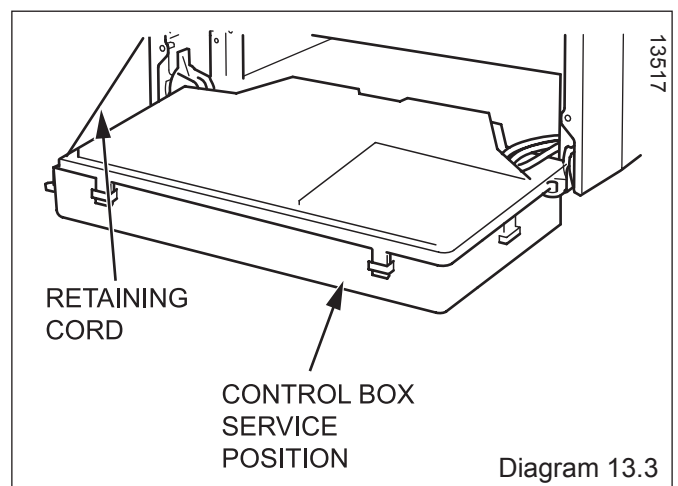

Diagram 13.3

13 Servicing

13.2 Spark Electrode

Disconnect the spark electrode plug and earth lead. Remove the two securing screws and withdraw the spark electrode carefully from the combustion chamber, see diagram 13.4. Inspect the tips for damage.

Clean away any debris and check the spark gap is 3.5 to 4.5 mm.

Check the electrode gasket for signs of damage and replace if necessary.

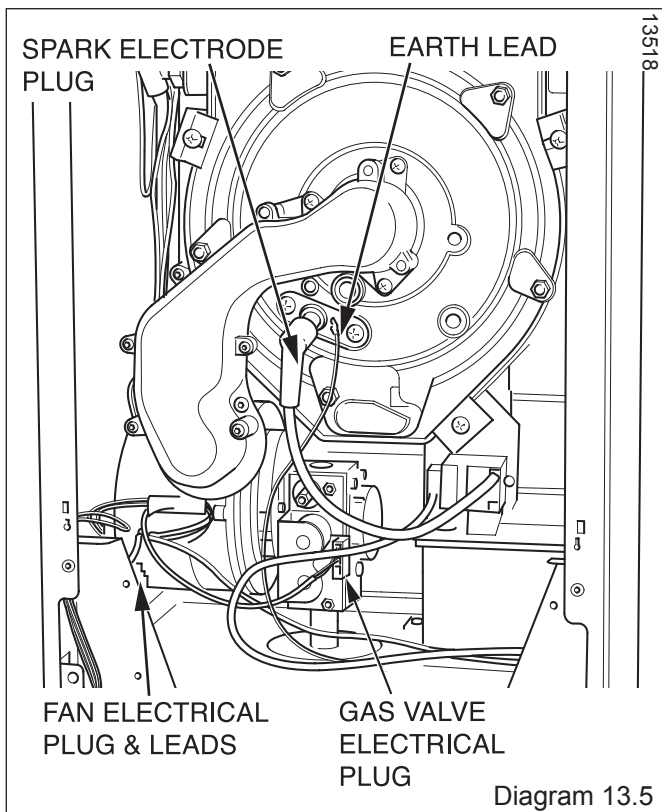
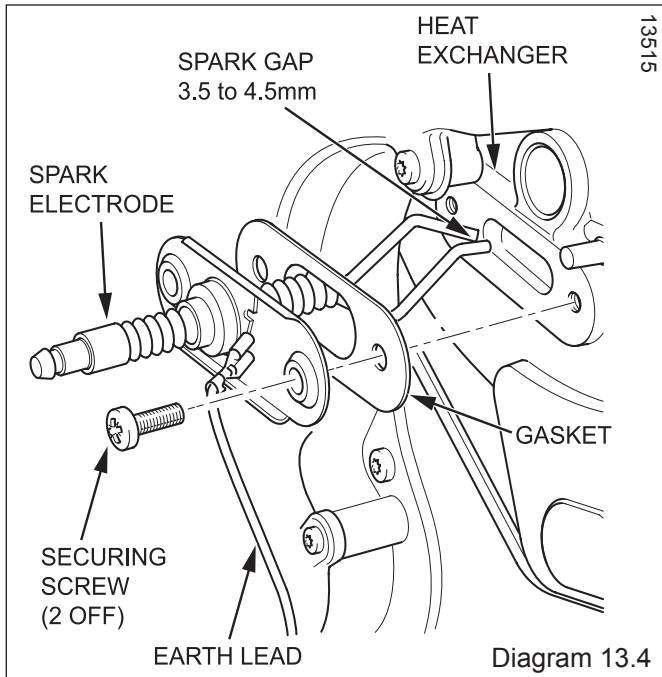

13.3 Burner

NOTE:

- The following procedure will require that you replace the burner door seal and nyloc nuts.
- Removal of the burner is not necessary during a normal service, but if it is removed it will require a new gasket, see diagram 13.6.
- When replacing ensure that the sealing grommet, situated below the gas valve is correctly re-seated.

Disconnect the gas valve electrical plug at the gas valve, see diagram 13.5.

Disconnect the electrical plug from the fan.

Disconnect the spark electrode plug and earth lead, refer to diagram 13.6.

Remove the gas pipe retaining clip.

Remove the five combustion chamber/burner door securing nuts, see diagram 13.7, these should be discarded and replaced with the new nylocs nuts supplied in the burner door seal kit.

Gently remove the fan, gas valve and burner assembly from the combustion chamber.

Clean the burner with a soft brush taking great care not to damage the front insulation. DO NOT use wire or sharp instruments to clean the holes of the burner.

Inspect the burner for any signs of damage.

Remove and discard the burner door seal and replace with new, see diagram 13.7.

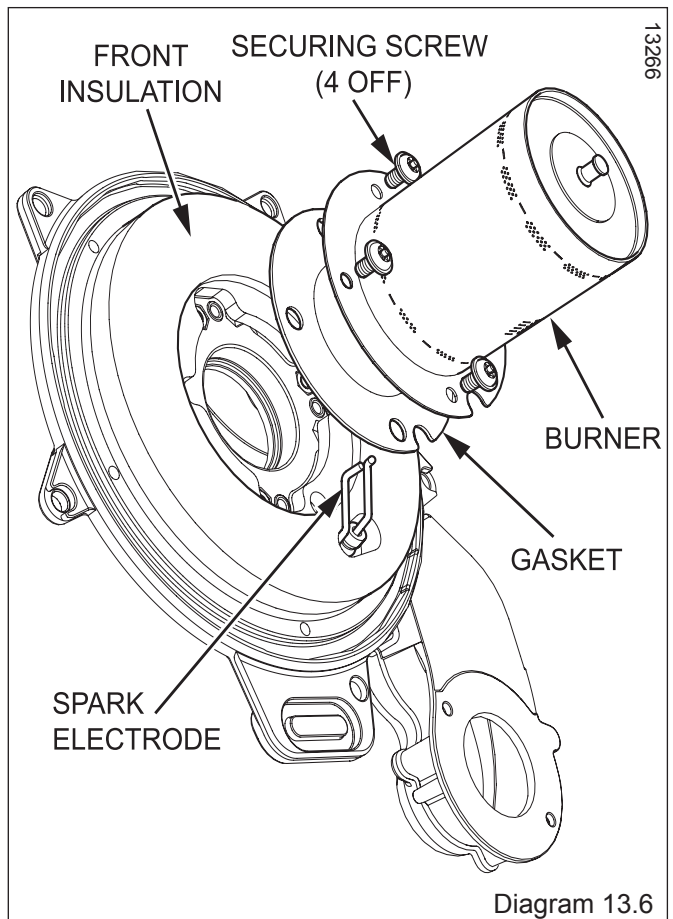

13 Servicing

13555

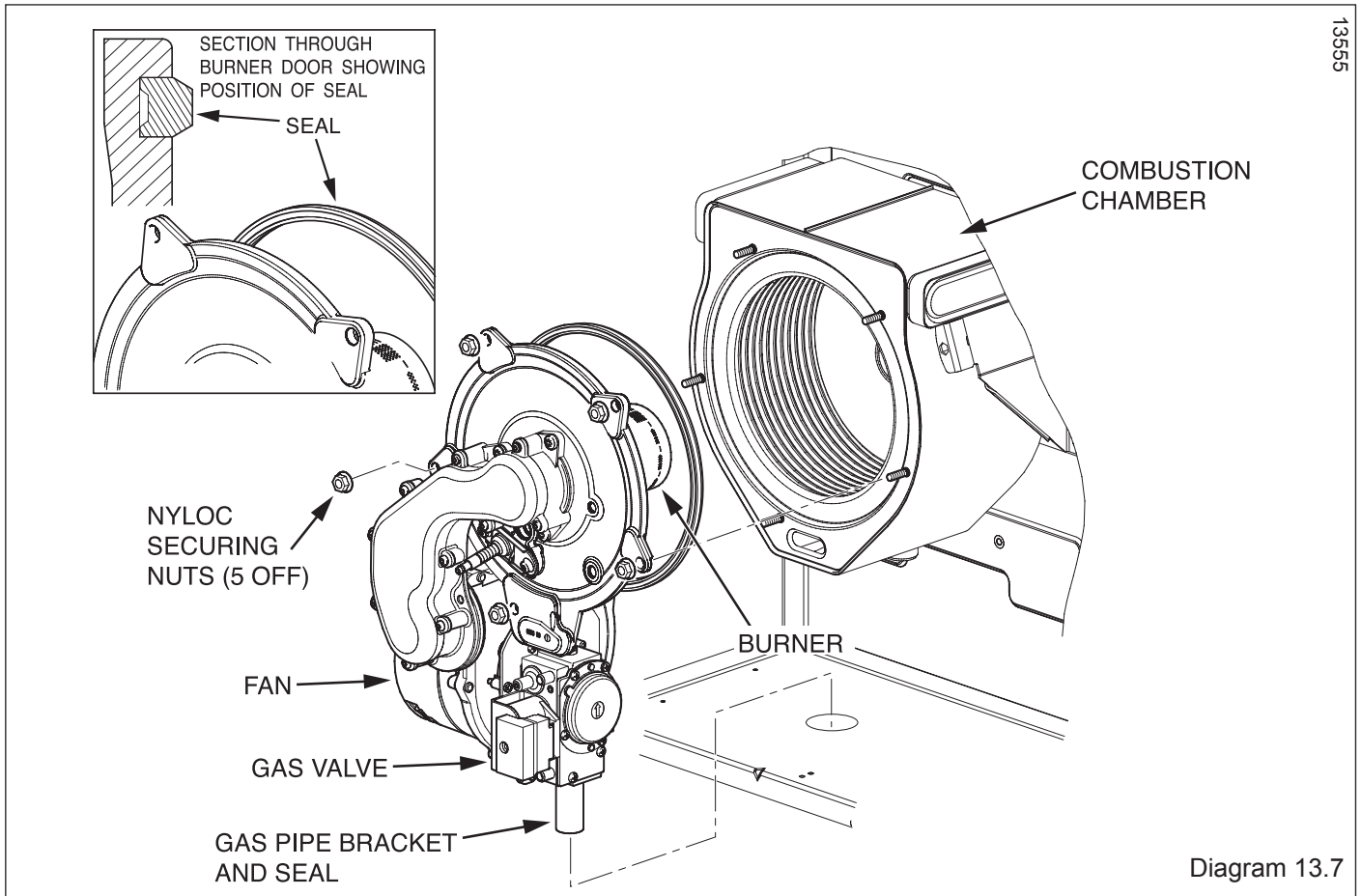

13.4. Combustion Chamber and Heat Exchanger

Remove loose debris from inside the combustion chamber using a soft brush and vacuum cleaner.
Carefully flush by spraying water into the heat exchanger, any remaining debris should pass through the condensate trap (Ensure the water is kept away from electrical components).

13.5 Inner Casing Panel Seal check

Check the condition of the seal, if worn or damaged remove the seal and thoroughly clean the casing surface before fitting the new seal, see diagram 13.8.
Refit the inner casing panel.

NOTE: Ensure the seal is fitted correctly giving an airtight joint.

13.6 Service Completion

Re-check the combustion as described at the beginning of this section.
On completion of the service the "Benchmark" Service Record should be completed.

NOTE: If the burner is not to be serviced, do not perform the following instructions 13.5, 13.6, 13.7 and 13.8 but continue to section 13.9 to complete the servicing.

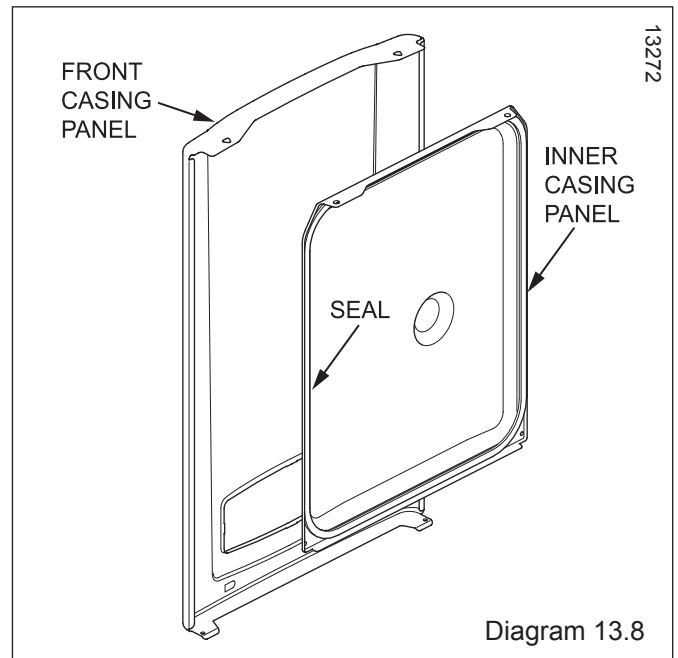

13272

14 Fault Finding

14.1 Preliminary fault finding

The following checks should be performed before proceeding onto specific diagnostics:

- Check the external electrical supply to the boiler is on and a supply of 230V is present at the 'L' and 'N' terminals on the installer interface, refer to section 11.5 for access and diagram 14.4.
- Check the electrical installation and appliance, carry out tests for earth continuity, polarity, short circuit and resistance to earth, using a suitable multimeter.

An aid to test

Remove the front casing panel, see diagram 13.2 and the control panel securing screw, see diagram 14.1 then lower into service the position.

Remove the rear panel by prising the retaining clips, see diagram 14.1.

Carry out the tests at connector plug X17, see diagram 14.2. Check chassis earth at a bare metal point on the boiler.

- Check that there is a gas supply to the boiler and the gas service isolation valve is turned on, see diagram 12.2.
- Check pressure at the gas service isolation valve, refer to section 12.5.
- Check that the heating system pressure indicates at least 1mb, if not, fill and vent the system as described in section 12.2.
- Check that all external controls are on.
- Check the functional flow diagram, 14.5.

14.2 Fault Codes

Fault codes take priority over all other display functions in the event of a fault occurring, refer to diagram 14.6.

If multiple faults occur the codes will be displayed for approx. 2 seconds, alternatively.

14.3 Fault Memory

On the left hand side of the ebox there are three buttons, see diagram 12.1, for use only by the installer, these can only be accessed when the case is removed.

The Fault memory stores details of the ten most recent faults. Refer to diagram 12.1.

To access this menu:

- Press and hold 'MODE' and '-' for 5 seconds.
- Press '+' button to scroll back through the fault memory (Position 1 is most recent), see fault memory display.

To exit this menu, press the 'MODE' button.

14.4 Diagnostic Menu

The Diagnostic Menu provides the ability to view and change certain parameters. See diagram 14.8 for available parameters.

14.5 Status Codes

The status codes provide information about the current operating condition of the boiler and can be accessed through the diagnostic display, refer to diagram 14.9.

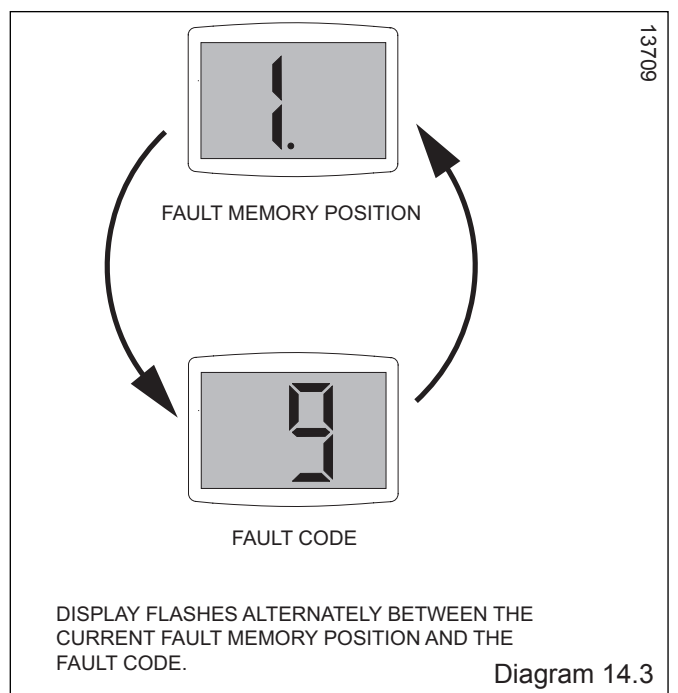
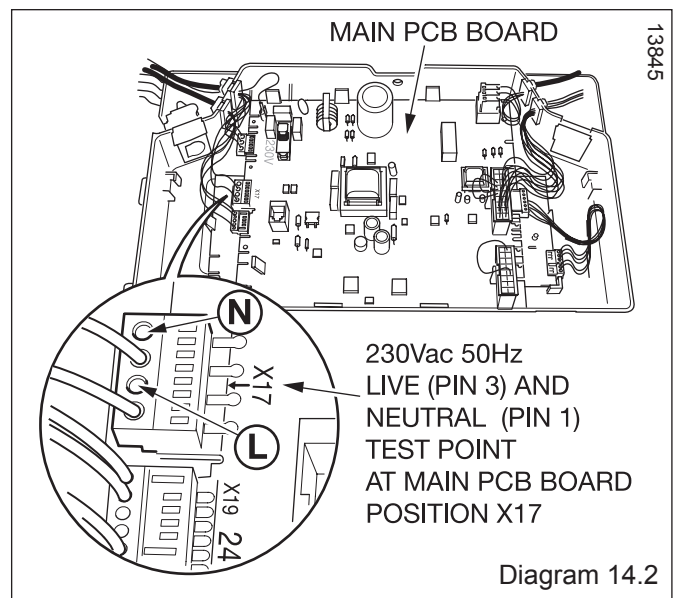
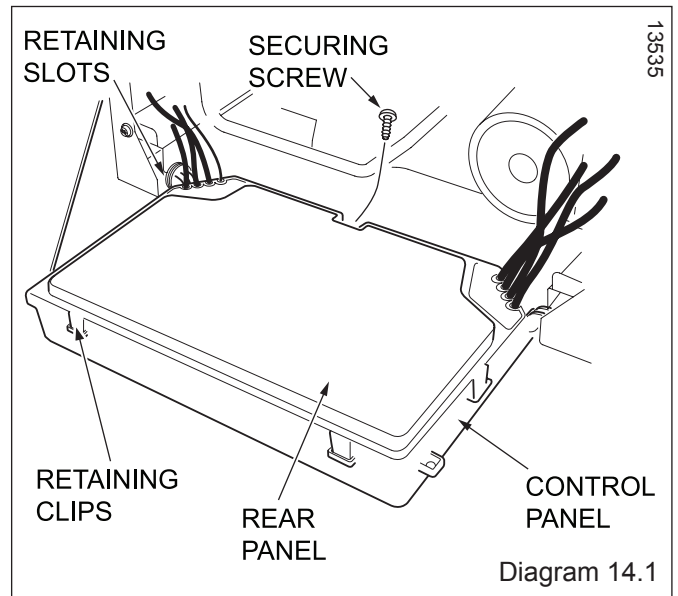

14 Fault Finding

13706

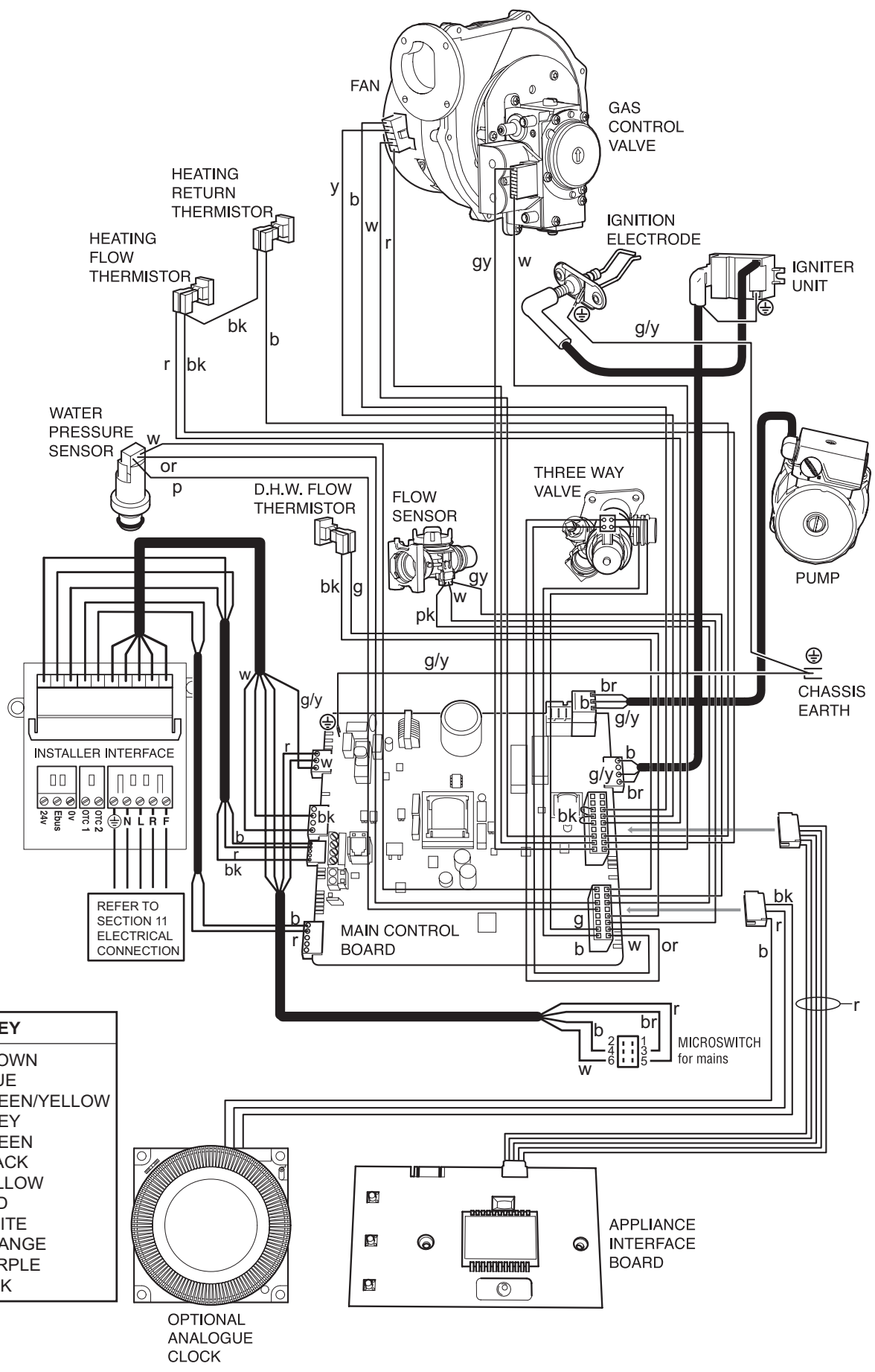

KEY	
br	BROWN
b	BLUE
g/y	GREEN/YELLOW
gy	GREY
g	GREEN
bk	BLACK
y	YELLOW
r	RED
w	WHITE
or	ORANGE
p	PURPLE
pk	PINK

Diagram 14.4

14 Fault Finding

13012

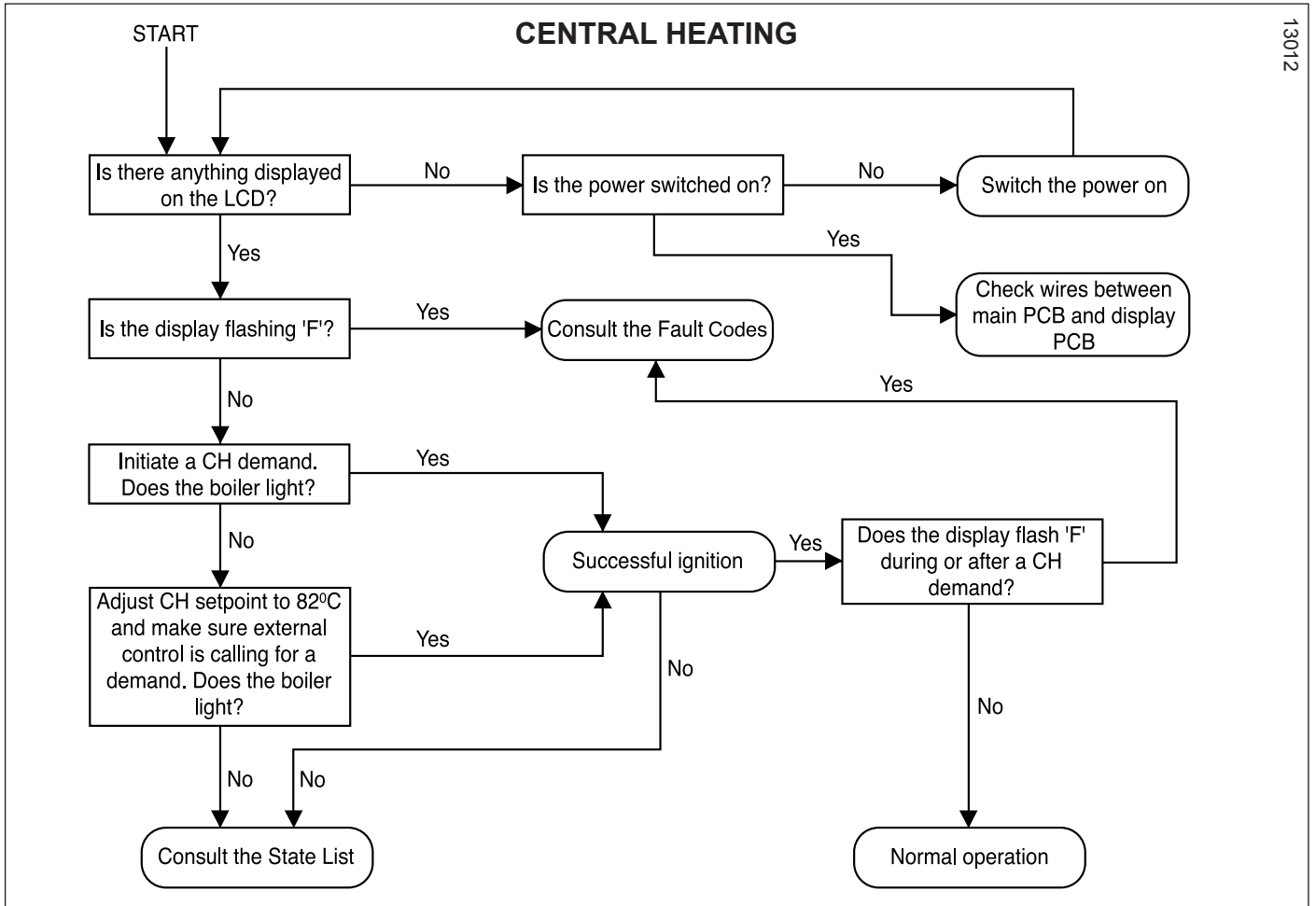

13015

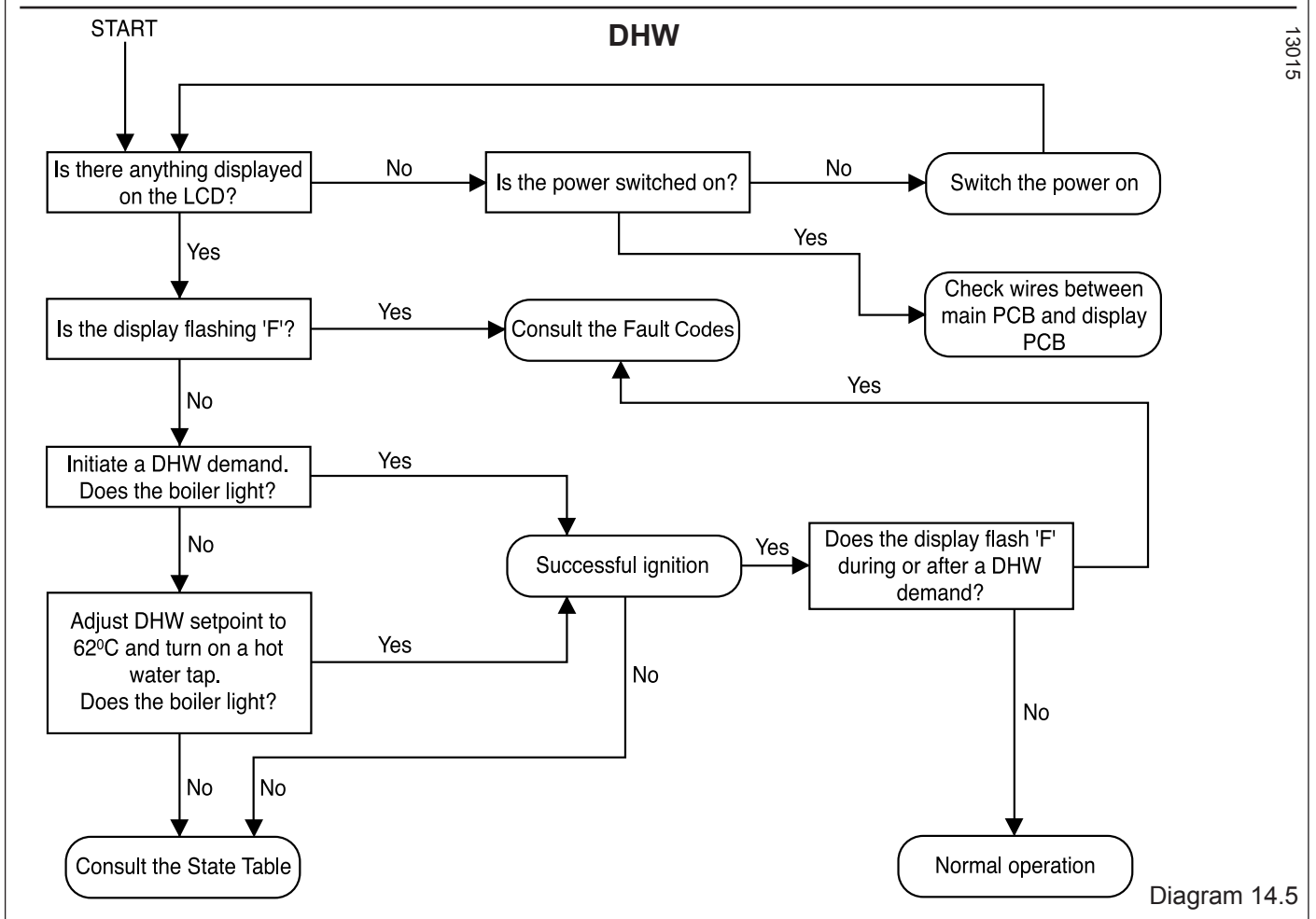

Diagram 14.5

14 Fault Finding

13860

Fault Codes

CODE	DESCRIPTION	POSSIBLE CAUSE
F1	Boiler has attempted to light 5 times and failed on all occasions	Gas tap is closed. Gas valve connector is loose, unconnected, faulty, or wires are trapped. Ignitor connectors are loose, unconnected, faulty, trapped. Faulty Ignitor. Low gas inlet pressure. Incorrect gas valve adjustment. Electrode Ignition leads loose, unconnected, faulty, trapped. Electrode broken, defective, or position incorrect. Air inlet blocked, flue inlet blocked, flue duct leaking. Earthing connection loose, disconnected. Condensate blocked.
F3	Fan fault	Fan speed incorrect. Fan connector loose, unconnected, faulty or wires trapped. Faulty fan.
F4	Flame goes out whilst lit during a demand	Gas tap is closed. Gas valve connector is loose, unconnected, faulty, or wires are trapped. Ignitor connectors are loose, unconnected, faulty, trapped. Faulty Ignitor. Low gas inlet pressure. Incorrect gas valve adjustment. Electrode Ignition leads loose, unconnected, faulty, trapped. Electrode broken, defective, or position incorrect. Air inlet blocked, flue inlet blocked, flue duct leaking. Earthing connection loose, disconnected. Condensate blocked.
F5	Overheat	Boiler has overheated – allow to cool then press reset button
F6	Central Heating Flow Thermistor connection fault	Thermistor wires unconnected, faulty, trapped.
F9	Pressure	Water pressure connector loose, unconnected, faulty or wires trapped. Water Pressure Sensor faulty Pump ceased, faulty.
F10	Central Heating Return Thermistor connection fault	Thermistor wires unconnected, faulty, trapped.
F11	Flow and/or return NTC faulty	Thermistor wires unconnected, faulty, trapped.
F13	PCB Memory or sensing fault	Loose connections on Main PCB or display PCB. Central Heating Flow or Return Thermistor wires unconnected, faulty, trapped. Electrode Ignition leads loose, unconnected, faulty, trapped. Earthing connection loose, disconnected.
F14	Gas Valve control defective	Gas valve connector loose, wires unconnected, faulty or trapped. Faulty main board. Faulty gas valve.
F15	eBus Voltage failure	Short circuit on eBus, overload on eBus.

If -9°C is displayed, check that the DHW thermistor wires are unconnected and are not faulty or trapped.

Diagram 14.6

14 Fault Finding

Fault Codes (continued)

13508

F22	Low Water pressure or Ignition temperature rise too slow	Not enough water in the system. Central Heating Flow or Return Thermistor wires loose, faulty, trapped. Central Heating Flow or Return Thermistor not connected to pipe correctly Air in the system. Faulty pump or pump speed too fast.
F25	Central Heating Flow temperature rise too high during operation. Central Heating Return temperature rise or temperature difference too high during operation. Central Heating Temperature difference (between Flow and Return) too high during operation.	Check thermistors are connected to pipes correctly. Air in the system. System is too restrictive.
F43	Generic error	Check all electrical connections - internal & external
F70	Software incompatible	Telephone Group Service
F77	Condensate pump error (Option)	Trapped, faulty wiring, blockage in condensate pump.
NO DISPLAY or 'Er' displayed - Check connection from display PCB to main PCB connector X51		

Diagram 14.6 continued.

14 Fault Finding

Diagnostic Menu

The Diagnostic Menu provides the ability to view and change certain parameters.

See Diagram 14.8 for available parameters.

To enter the diagnostic menu:

- a) Press and hold the 'MODE' and '+' button for 5 seconds. The display will change to '0'.
- b) Use the '+' or '-' buttons to scroll to 95 (This is the installer level access password).
- c) Press and hold 'MODE' for 5 seconds to confirm, see diagram 14.6.

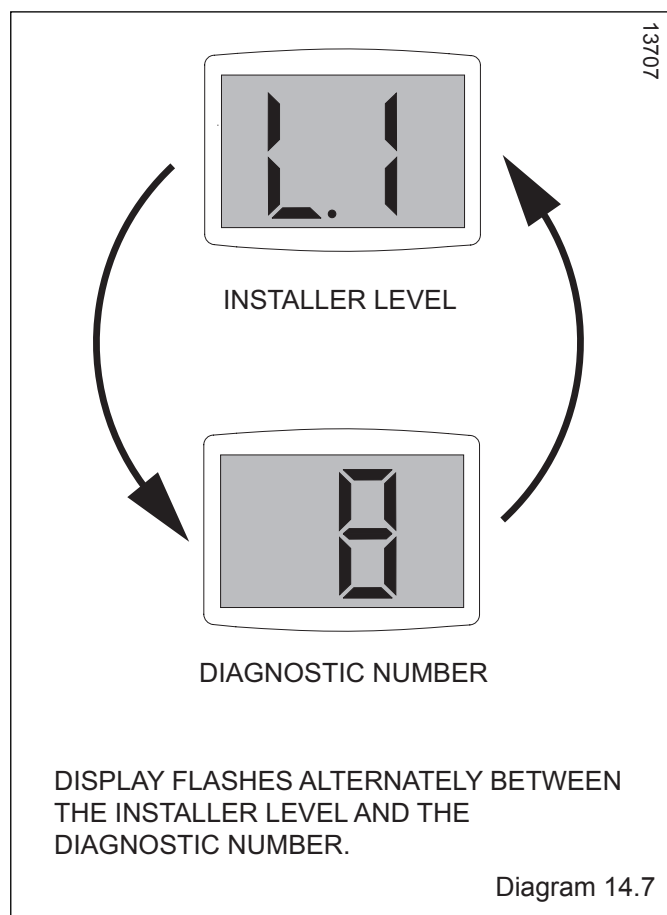

Use the '+' or '-' buttons to view the appropriate diagnostic number, see diagram 14.7.

- a) Press 'MODE' to see appropriate value.
- b) Press 'MODE' again to return to main diagnostic menu.
- c) The values can be changed by pressing '+' or '-' when the value is displayed.
- d) Press and hold 'MODE' 5 seconds to confirm.

(NOTE: Only certain parameters can be adjusted)

To exit the diagnostic menu press the 'MODE' and '+' buttons.

14 Fault Finding

Diagnostic Menu - Level 1 Installer Access

13454

Display	Description	Range
■ d.0	Heating part load	Adjustable heating part load in kW (factory setting: max. output)
■ d.1	Water pump over run time for heating mode	2 - 60 min (factory setting: 5 min)
■ d.2	Max. burner anti cycling period at 20°C Flow temperature	3 - 60 min (factory setting: 20 min)
d.4	Tank temperature	in °C -99 will be displayed. Reserved for future use.
d.5	Flow temperature setpoint	In °C, min. 38 and max. 82
d.8	External controls heat demand	0= no heat request (open) 1 = heat request (closed)
d.9	Flow target temperature from external intelligent control	In °C, minimum from ext. eBUS target value and target value terminal 7
d.10	Status central heating pump	1,2 = on, 0 = off
d.11	Status additional heating pump	1 to 100 = on, 0 = off
d.13	Hot water circulation pump (via accessory module)	1 to 100 = on, 0 = off
d.23	Summer/Winter function	1 = Winter, 0 = Summer
d.25	Hot water activation via eBUS Control	1 = yes, 0 = no
■ d.27	Option Relay 1	Reserved for future use
■ d.28	Option Relay 2	Reserved for future use
d.33	Fan speed target value	in rpm/10
d.34	Fan speed actual value	in rpm/10
d.35	Position of diverter valve	0 = Heating; 100 = Hot water; 40 = Centre position
d.40	Flow temperature	Actual value in °C
d.41	Return temperature	Actual value in °C
d.44	Ionisation current	Actual value in(10nA) > 80 no flame < 40 good flame
d.47	Outside temperature	in °C
d.60	Number of safety temperature limiter cut offs	Quantity
d.61	Number of lock outs	Number of unsuccessful ignitions in the last attempt
d.64	Average ignition time	In seconds
d.65	Maximum ignition time	In seconds
d.67	Remaining burner anti cycling time (block time)	Minutes
d.68	Unsuccessful ignitions in the first attempt	Quantity
d.69	Unsuccessful ignitions in the second attempt	Quantity
d.76	Appliance variant (device specific number)	00 to 99
d.80	Heating operating hours	in h
d.81	DHW operating hours	in h
d.82	Cycles in heating mode	Quantity
d.90	External intelligent control connect	1 = identified, 0 = unidentified (eBUS Address <= 1 0)
d.91	Internal Programmer type	0:24 hour (default) 1:7 day
■ d.92	Enable/Disable Internal Programmer	0: CH Off, DHW Off 1: CH Off, DHW On 2: CH On, DHW Off (Default) 3: CH On, DHW On
■ d.97	Activation of the second diagnostic level	Password needed
d.99	State List	(see State Lists table)

■ Indicates read and write function - all other diagnostics are read only

Diagram 14.8

14 Fault Finding

State list - Accessed through Diagnostic Codes - Level 1, Installer Access d.99

13011

STATE LISTS

	Central heating mode	Description
S.00	no heating required	} NORMAL OPERATING STATE FOR CH MODE
S.01	fan pre-run	
S.02	pump pre-run	
S.03	ignition	
S.04	burner on	
S.05	pump / fan overrun	
S.06	fan overrun	
S.07	pump overrun	
S.08	Anti cycling period	
	Domestic hot water mode	
S.10	domestic hot water demand	} NORMAL OPERATING STATE FOR DHW MODE
S.11	fan pre-run	
S.13	ignition	
S.14	burner on	
S.15	pump / fan overrun	
S.16	fan overrun	
S.17	pump overrun	
	Preheat mode	
S.20	domestic hot water cycling mode active	} NORMAL OPERATING STATE FOR PRE-HEAT MODE
S.21	fan pre-run	
S.22	Pump pre run	
S.23	ignition	
S.24	burner on	
S.25	pump / fan overrun	
S.26	fan overrun	
S.27	pump overrun	
S.28	Anticycling period	
	Special cases of status messages	
S.30	No Heating demand from external controls 230V	Check wiring in external controller. Check wiring at Installer Interface.
S.31	summer mode	Check CH setpoint / Check external controls
S.32	Antifreeze active – fan speed variation too high – waiting during blocking function	Check fan connection.
S.34	frost protection active (Priority 4)	Temperature below 8°C - check thermistor connection if this is not true.
S.36	No Heating demand from external controls 24V	Check wiring in external controller. Check wiring at Installer Interface.
S.42	Accessory Module is blocking burner operation	Check accessory module.
S.53	waiting time: temperature difference flow - return sensor too high (Check thermistor fit)	Check flow & return thermistor connections to pipes. Check harness connection to thermistor. Check harness wires are not trapped between any internal components.
S.54	waiting time: no water in system, temperature (gradient error) rise flow / return sensor too high	Check flow & return thermistor connections to pipes. Check harness connection to thermistor. Check harness wires are not trapped between any internal components.
S.76	Waiting period – pressure sensor	Check system pressure - default display.
S.96	Return-Sensor check is running, demand (DHW or heating) is blocked	Check return thermistor connection to pipe. Check harness connection to thermistor.
S.97	Water pressure sensor check is running, demand (DHW or heating) is blocked	Check connection to pressure sensor. Check pump has not seized.
S.98	Flow / Return - sensor check is running, demand (DHW or heating) is blocked	Check flow & return thermistor connections to pipes. Check harness connection to thermistor. Check harness wires are not trapped between any internal components.

Diagram 14.9

15 Replacement of Parts

15.1 General

IMPORTANT: The replacement of parts described in sections 15.5 to 15.9 and section 15.12 will require the removal of the burner module assembly and the replacement of the burner door seal and self locking nuts.

Replacement parts that have associated components that need replacing on removal, i.e. 'O' ring, seals, gasket, etc., will be supplied and should be fitted.

Replacement of parts must be carried out by a **competent person** approved at the time by the Health and Safety Executive.

Before replacing any parts the boiler should be isolated from the mains electric supply and the gas should be turned off at the gas service isolation valve on the boiler, see diagram 12.2.

Unless stated otherwise parts are replaced in the reverse order to removal.

After replacing any parts always test for gas soundness and if necessary carry out functional test of the controls.

For replacement of parts the front casing and the inner casing panel of the boiler will need to be removed. To remove undo the two screws on the underside of the front casing and lift off. Undo the two screws on the front of the inner front panel and lift off.

If the appliance site situation has sufficient side clearances the side panels can be hinged sideways and removed to aid replacement of parts.

To remove a side panel undo the three screws securing each side panel to the boiler, two at the front and one at the top.

Draining of Boiler Heating Circuit

Drain down the Heating Circuit of the boiler only, by closing the heating flow and return isolating valves, see diagram 8.1.

Attach a length of hose to the drain point and open the drain valve, see diagram 8.1.

After replacing part, close the drain valve and remove the hose. Open the heating flow and return isolating valves and refill, vent and pressurise the heating circuit, see section 12.6.

Check for leaks.

Draining of Boiler Hot Water Circuit

Drain the Domestic Hot Water circuit by closing the cold-water isolation valve on the wall mounting jig.

Open one or more hot water taps to drain the hot water circuit.

After replacing part open the cold-water isolation valve and slowly open a hot water tap to remove air. Close the hot water tap and check for any leaks.

15.2 Spark Electrode

For access, refer to section 15.1.

Refer to section 13.2 for removal.

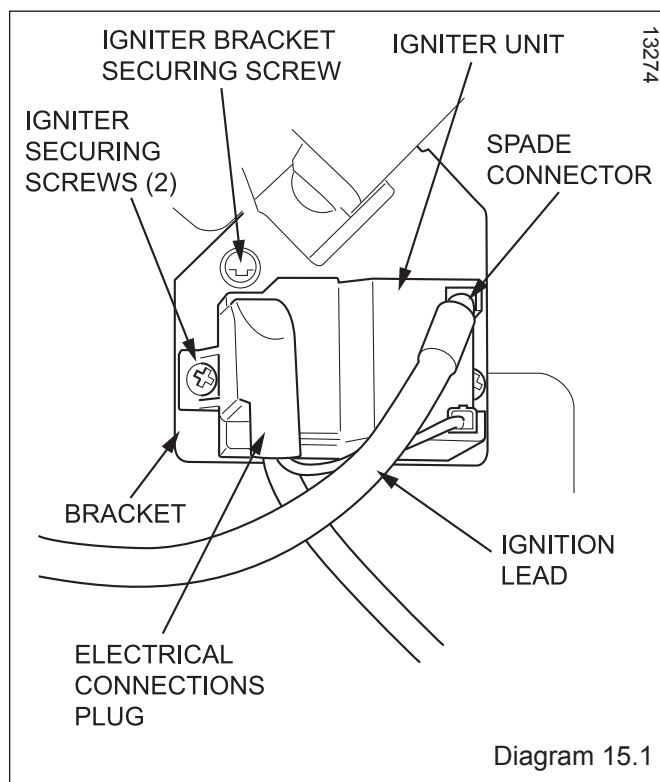

15.3 Igniter Unit

For access, refer to section 15.1.

Remove ignition lead and electrical connections then remove igniter unit by removing two securing screws, see diagram 15.1.

15.4 Ignition Lead

For access, refer to section 15.1.

Pull the spark plug style connector off the spark electrode, refer to diagram 13.6. and the spade connector connected to the igniter unit, see diagram 15.1.

15 Replacement of Parts

15.5 Gas Valve

For access, refer to section 15.1.

Refer to section 13.3 for removal of the fan, gas valve and burner assembly.

Before removing the gas valve note its orientation in relationship to the fan.

Remove the three securing screws, which also secures the plastic swirl plate to the venturi on the fan, see diagram 15.2.

Withdraw the gas valve.

After assembly test for gas tightness and purge in accordance with the current issue of BS6891 or in IE, the current edition of I.S.813 "Domestic Gas Installations".

Check the combustion CO₂ and adjust if necessary, see section 13.

15.6 Fan

For access, refer to section 15.1.

Refer to section 12.3 for removal of the fan, gas valve and burner assembly.

Remove the gas valve as described in section 15.5.

Remove the two securing screws, nuts and washers to separate the fan from the gas manifold extension tube and gas manifold, see diagram 15.3.

After assembly test for gas soundness and purge in accordance with the current issue of BS6891 or in IE, the current edition of I.S.813 "Domestic Gas Installations".

15.7 Burner

For access, refer to section 15.1.

Refer to section 13.3 for removal of the fan, gas valve and burner assembly.

Remove the four screws that secure the burner, see diagram 13.7.

NOTE: The burner will require a new gasket.

15.8 Front Insulation

For access, refer to section 15.1.

Refer to section 13.3 for removal of the burner module.

Remove burner as described in section 15.7.

Remove spark electrode, see section 15.2.

NOTE: The burner will require a new gasket when refitted.

15.9 Rear Insulation

For access, refer to section 15.1.

Refer to section 13.3 for removal of the burner module.

Remove securing screw and washer in the centre of the insulation and withdraw insulation, see diagram 15.4.

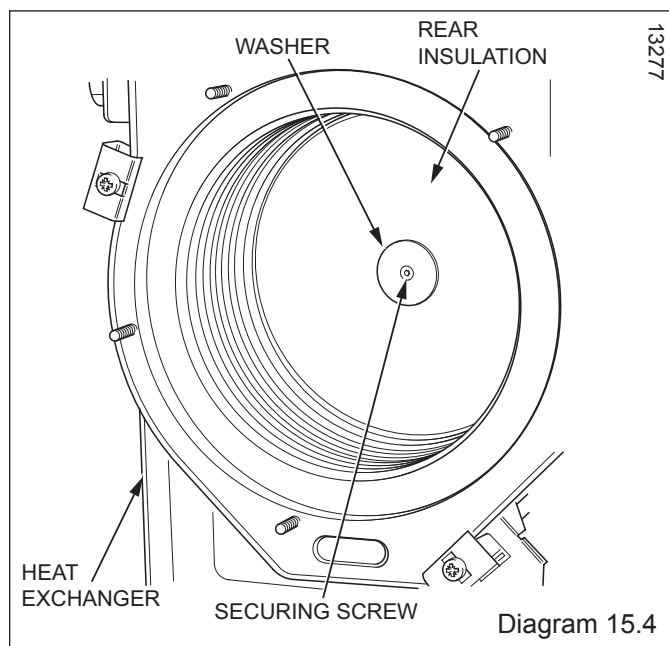
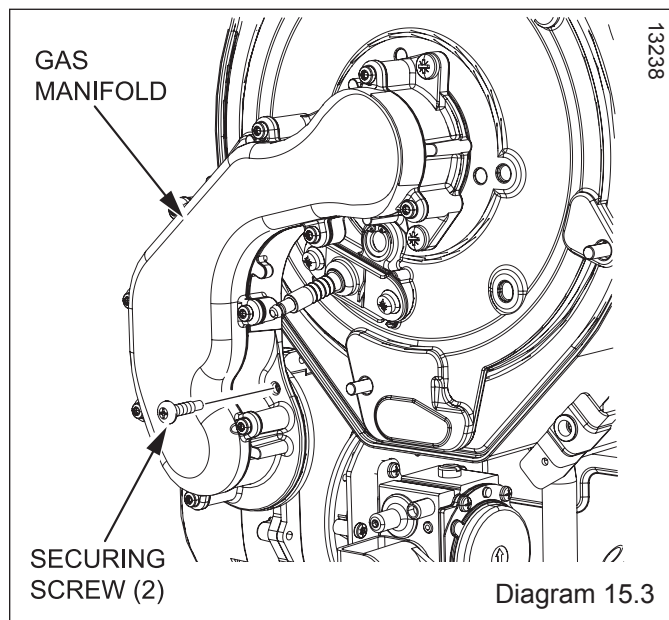
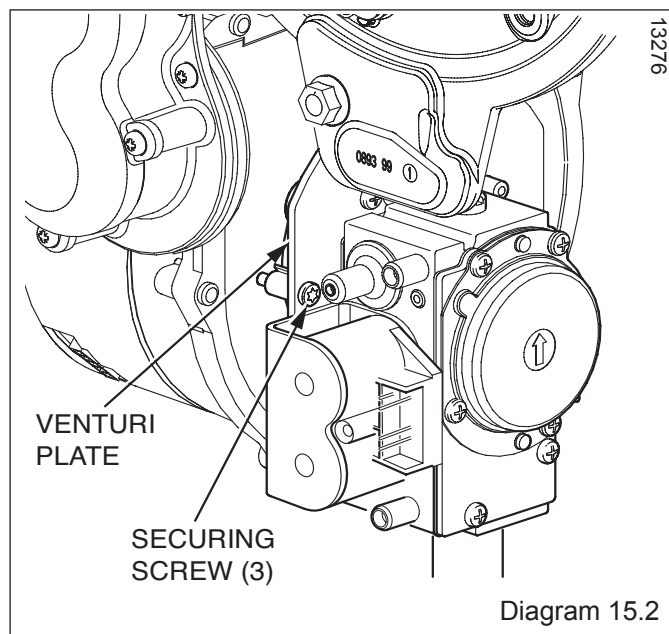

15 Replacement of Parts

15.10 Viewing Window

For access, refer to section 15.1.

Refer to diagram 15.5.

Remove circlip.

Remove steel washer.

Remove glass.

Remove fibre washer.

15.11 Expansion Vessel

For access, refer to section 15.1.

Drain the boiler heating circuit as described in the appropriate section of 15.1.

Undo the coupling at the base of the vessel, see diagram 15.6.

While holding the vessel remove the securing bolt on the top panel of the boiler. Remove upper support bracket.

Fit a new gasket between the expansion vessel and coupling.

Refill, vent and pressurise the boiler.

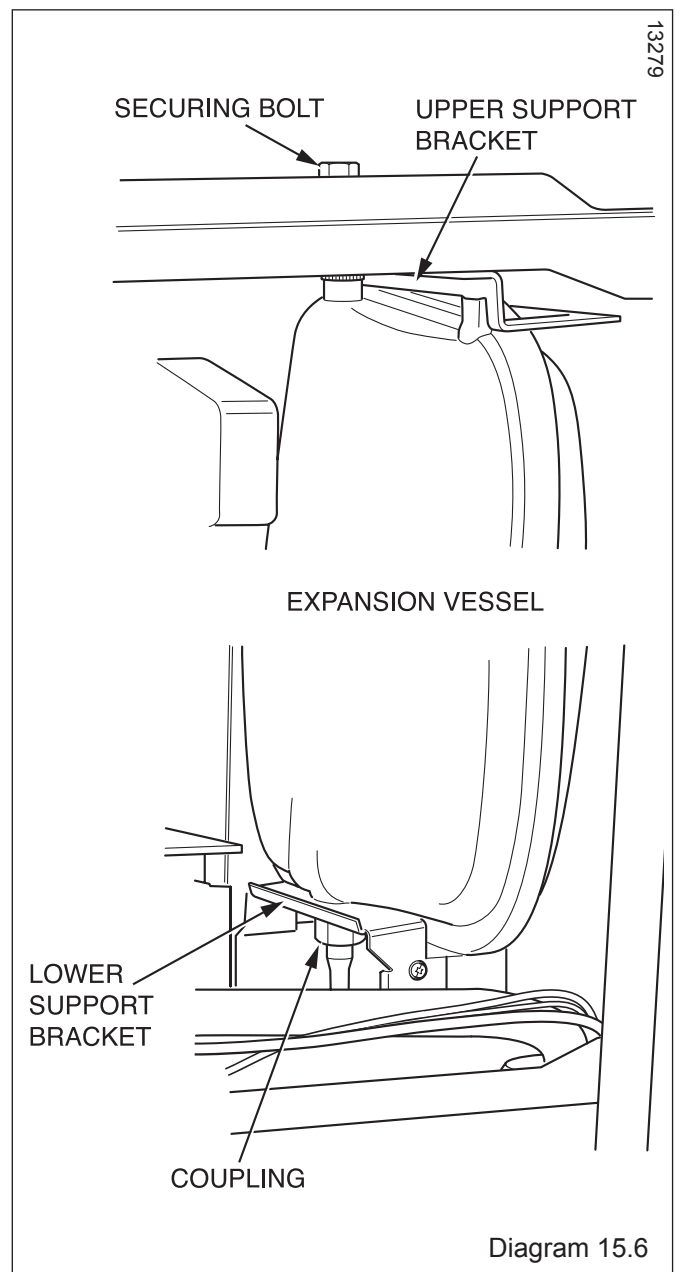
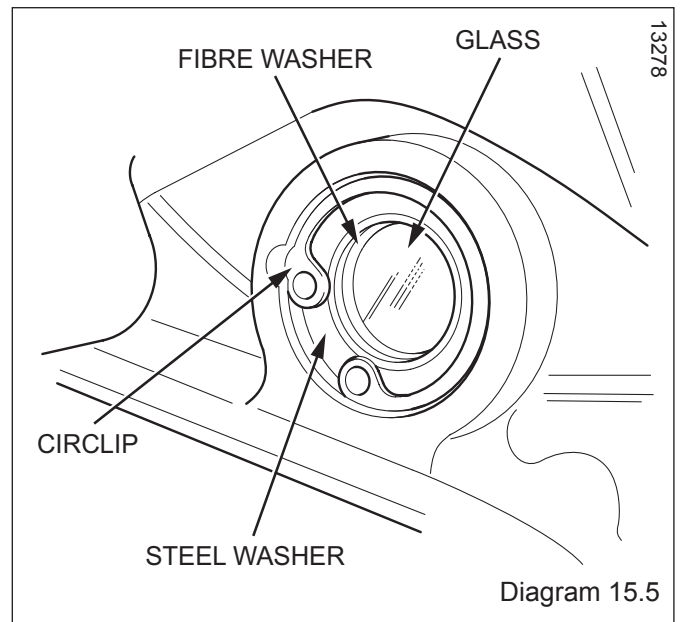

15 Replacement of Parts

15.12 Heat Exchanger

Refer to Manual Handling section on page 65.

For access, refer to section 15.1.

Refer to section 13.3 for removal of the fan, gas valve and burner assembly.

Drain the boiler heating circuit as described in the appropriate section of 15.1.

Drain the boiler hot water circuit as described in the appropriate section of 15.1.

Remove the clip securing the condense hose adapter to heat exchanger, refer to diagram 15.7.

Pull the condense pipe adapter off the heat exchanger connection.

Disconnect the central heating flow and return pipes from the heat exchanger.

Move the pipes away from the heat exchanger.

Slacken the three heat exchanger securing screws and clamps (two at the top and one at the bottom) to remove the heat exchanger, see diagram 15.8.

CAUTION: There will be water in the heat exchanger.

Carefully ease heat exchanger out.

15.13 Flue Hood

For access, refer to section 15.1.

Remove heat exchanger as described in section 15.12.

Remove the two securing screws and pull the flue hood down and away from the flue hood bracket and flue elbow, see diagram 15.9.

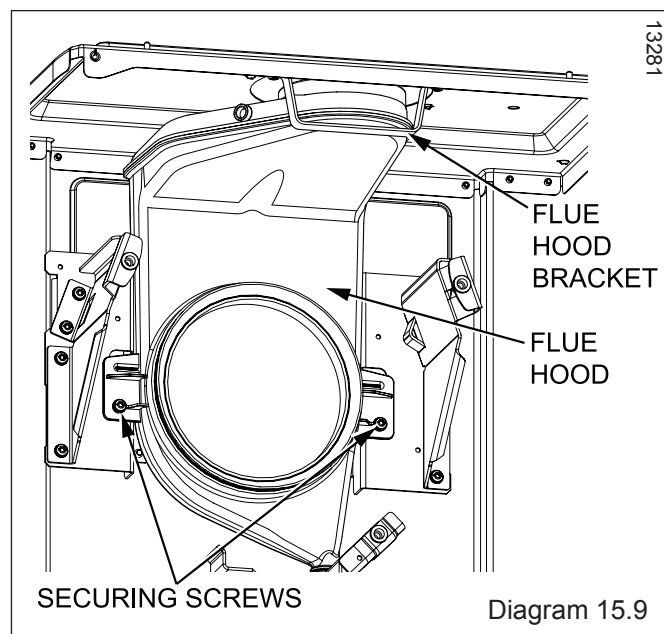
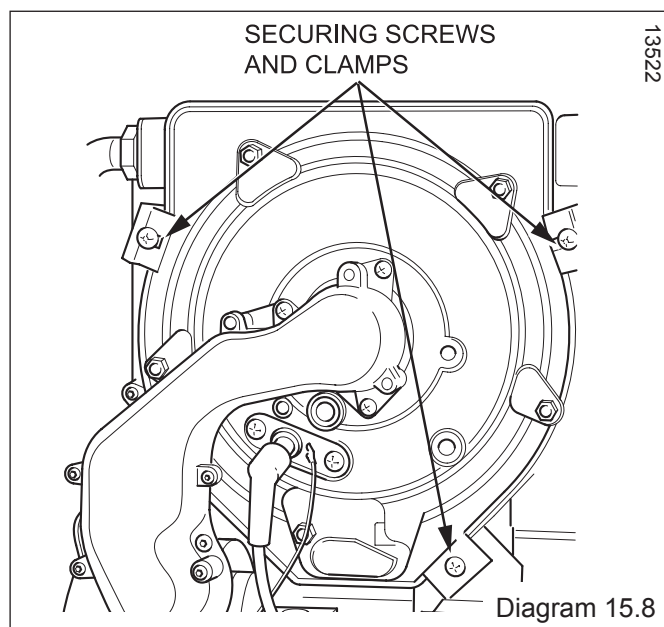
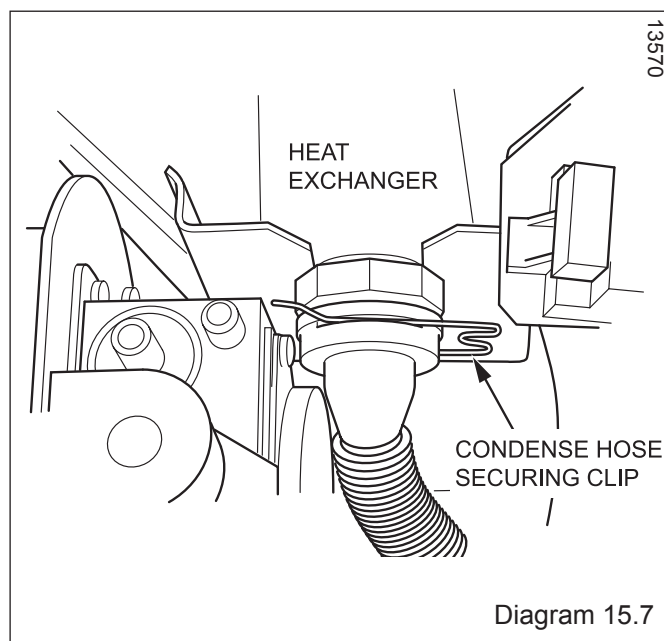

15 Replacement of Parts

15.14 Heating Flow Thermistor

For access, refer to section 15.1.

Refer to diagram 15.10.

Remove the electrical connections from the thermistor.

Remove the retaining clip from the flow pipe.

NOTE: When reconnecting, the polarity of the wiring to thermistors is not important.

15.15 Heating Return Thermistor

For access, refer to section 15.1.

Refer to diagram 15.10.

Remove the electrical connections from the thermistor.

Remove the retaining clip from the return pipe.

NOTE: When reconnecting, the polarity of the wiring to thermistors is not important.

15.16 Condense Drain

For access, refer to section 15.1.

Refer to diagram 15.11.

Remove the igniter unit as described in section 15.3 to improve accessibility.

Remove the securing clip from the heat exchanger adapter, then disconnect the adapter and flexible hose.

Lift the siphon adapter and hose out of the condensate trap and siphonic drain, do not disconnect the hose.

Disconnect the drain connection.

Slacken to disengage but do not remove the two securing screws.

The condensate trap will contain water, lift taking care not to spill the water.

After replacement and before fitting the adapter fill the trap with water.

Cleaning

Remove the condensate trap as previously described.

Remove the float to clean it.

Remove any solids found.

Flush water through the trap to remove any remaining solids.

Check for any debris in the outlet hose of the condensate drain and clean as necessary.

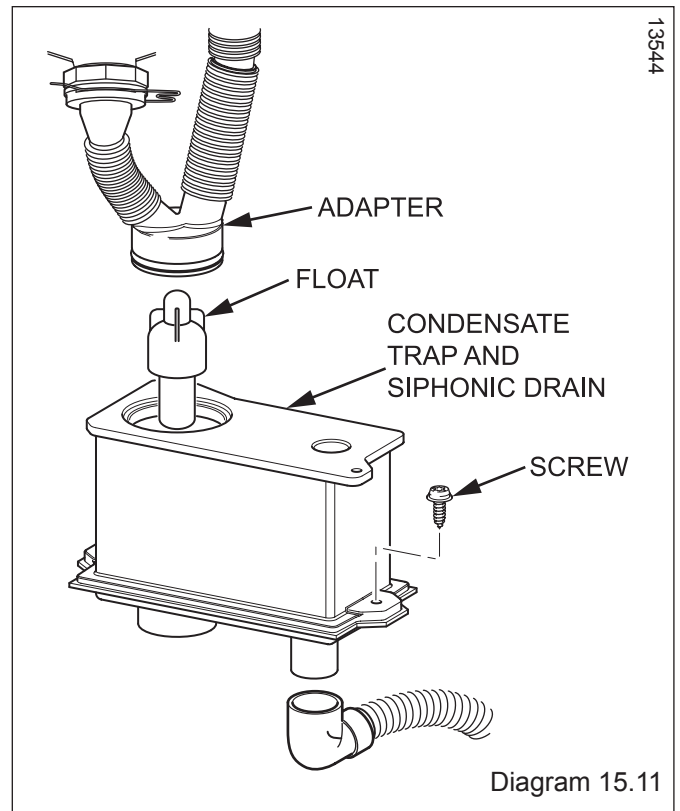
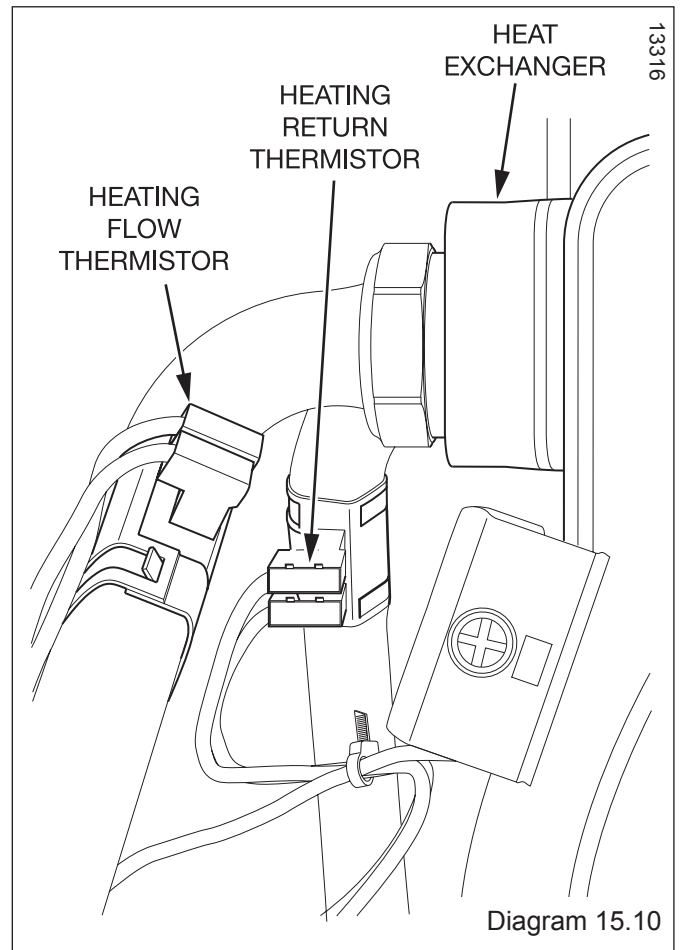

15 Replacement of Parts

15.17 Pump (head only)

For access, refer to section 15.1.

Drain the boiler heating circuit as described in the appropriate section of 15.1.

Refer to diagram 15.12.

Remove the four cap head screws.

Carefully remove the pump head together with cable. Do not strain cable.

Support the pump head, unscrew cable cover at the side of pump head and take off.

Disconnect wiring from pump head.

Reconnect wiring to new pump head and fit cover.

Fit the new pump head with 'O' ring.

Complete pump replacement

For access, refer to section 15.1.

Drain the boiler heating circuit as described in the appropriate section of 15.1.

Refer to diagram 15.12, 15.13.

Remove the pump head as described in section 15.17.

Remove the safety discharge valve as described in section 15.18.

Disconnect the expansion vessel pipe at the coupling, see diagram 15.6 and at the pump housing by removing the securing clip, see diagram 15.12.

Disconnect the central heating flow pipe union connection and withdraw the pump securing clip.

Spring back the rear location bracket to release the pump housing and gently rotate backwards and forwards whilst easing the pump to the right to disengage from the 3 way valve.

15.18 Safety Discharge Valve

For access, refer to section 15.1.

Drain the boiler heating circuit as described in the appropriate section of 15.1.

Refer to diagram 15.13.

Undo the safety discharge valve union and remove from the pipework.

Remove the securing clip and withdraw the safety discharge valve.

Fit new 'O' ring.

Refill, vent and pressurise the boiler.

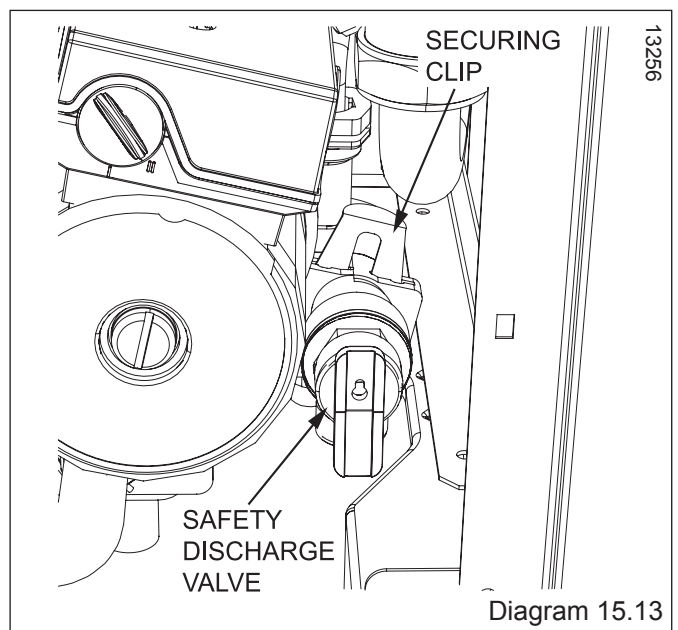
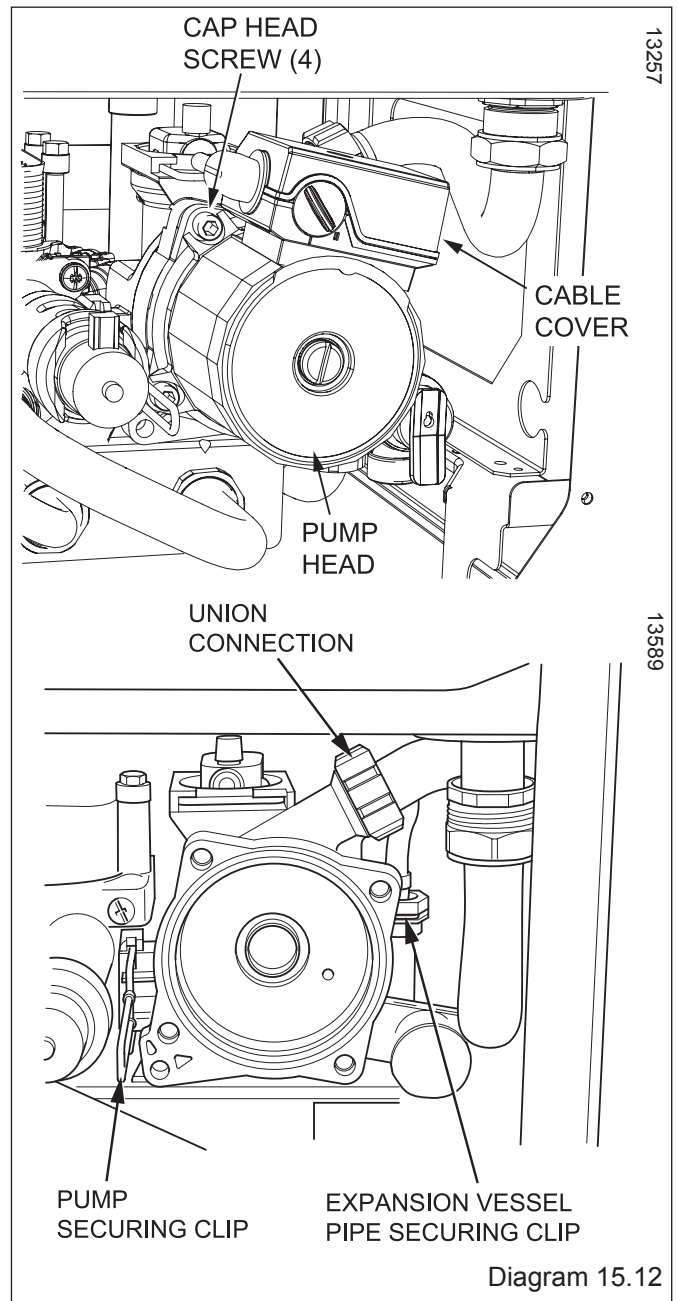

15 Replacement of Parts

15.19 Domestic Hot Water Thermistor

For access, refer to section 15.1.

Refer to diagram 15.14.

Disconnect the domestic hot water thermistor electrical connections

Remove hot water thermistor and retaining clip.

Remove domestic hot water thermistor from clip.

NOTE: When reconnecting electrical connections, polarity is not important.

Carry out a functional test of the controls.

15.20 Automatic Air Vent

For access, refer to section 15.1.

Drain the boiler heating circuit as described in the appropriate section of 15.1.

Refer to diagram 15.15 and gain access through the plastic maintenance cover.

Unscrew the automatic air vent.

Fit the new automatic air vent and 'O' ring ensuring the vent cap is left loose.

Refill, vent and pressurise the boiler.

15.21 Low Water Pressure Sensor

For access, refer to section 15.1.

Drain the boiler heating circuit as described in the appropriate section of 15.1.

Refer to diagram 15.16.

Disconnect the electrical lead.

Remove the retaining clip, remove the low water pressure sensor.

Fit new 'O' ring.

Fit the new low water pressure sensor.

Refill vent and pressurise the boiler.

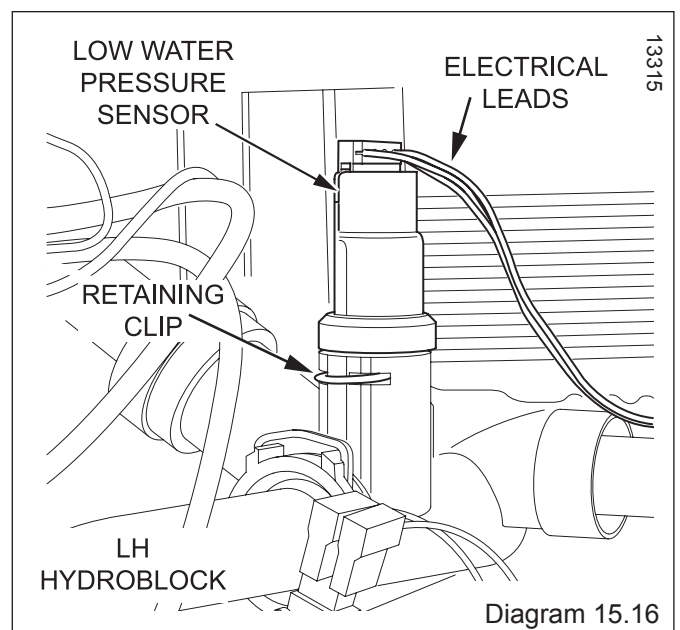
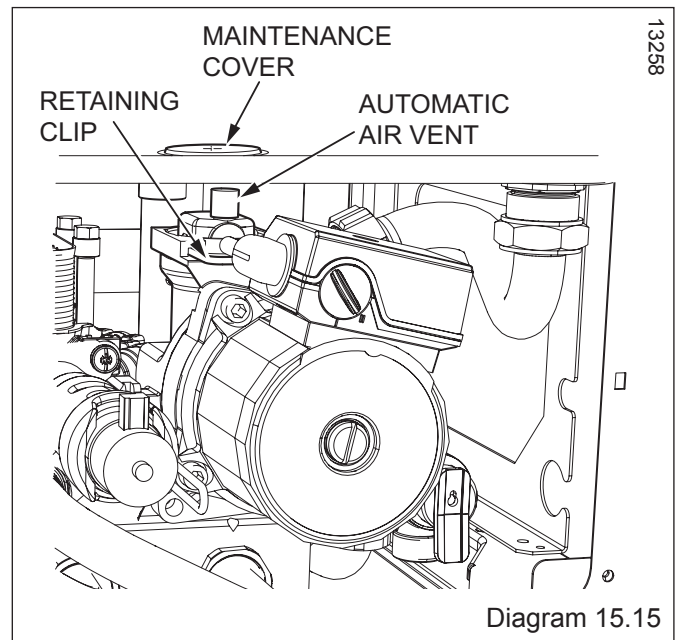
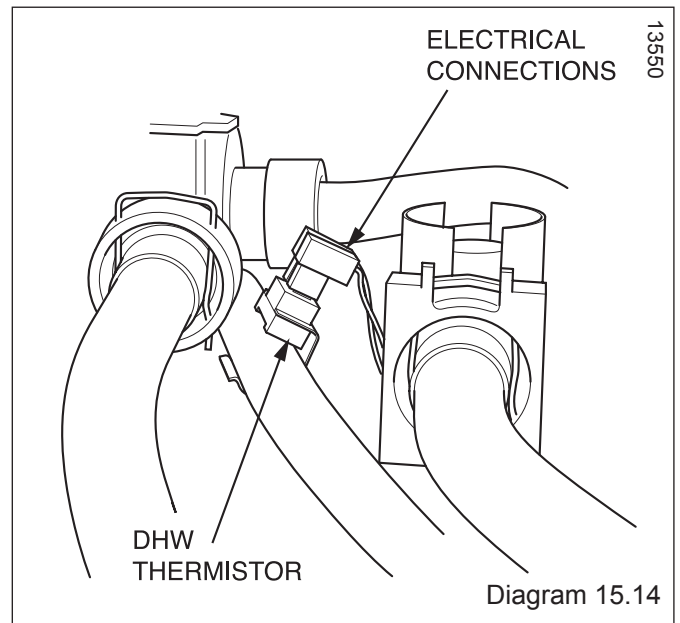

15 Replacement of Parts

15.22 Flow Sensor

For access, refer to section 15.1.

Drain the boiler hot water circuit as described in the appropriate section of 15.1.

Refer to diagram 15.17.

Remove the front securing clip.

Disconnect the domestic cold water pipe at the bulkhead connection and remove the pipe.

Remove the rear securing clip.

Disengage the flow sensor housing.

Remove the electrical connection.

Fit new 'O' rings.

After replacing the flow sensor, open the cold-water isolation valve and slowly open a hot water tap to remove air.

15.23 Bypass

For access, refer to section 15.1.

Drain the boiler heating circuit as described in the appropriate section of 15.1.

Refer to diagram 15.18.

Remove the retaining clip to remove the bypass screw.

Fit new 'O' rings.

After replacing the bypass, refill, vent and pressurise the boiler.

15.24 Three Way Valve

For access, refer to section 15.1.

Drain the boiler heating circuit as described in the appropriate section of 15.1.

Refer to diagram 15.18.

Remove the retaining clips and three securing screws to remove the three way valve.

Undo the securing nut to check the solenoid actuator, spindle and shaft.

Fit new 'O' rings before replacing the three way valve assembly.

Refill, vent and pressurise the boiler.

15.25 Plate-to-Plate Heat Exchanger

For access, refer to section 15.1.

Drain the boiler heating and domestic hot water circuits as described in the appropriate sections of 15.1.

Refer to diagram 15.19.

Remove the 4 securing screws.

Remove the plate-to-plate heat exchanger by lifting it up and over the top of the left hand hydroblock.

When replacing the plate-to-plate heat exchanger ensure that the four rubber sealing washers are fitted into the hydroblock.

NOTE: The plate-to-plate heat exchanger only fits one way.

Refill, vent and pressurise the boiler.

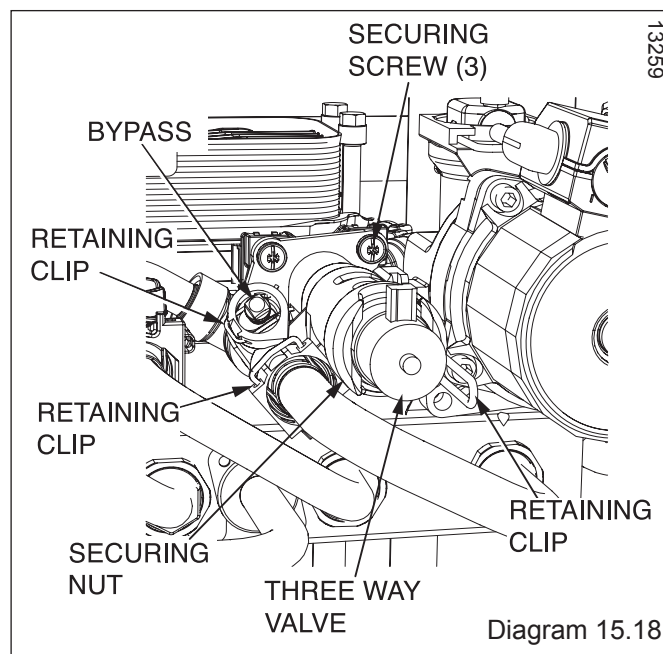
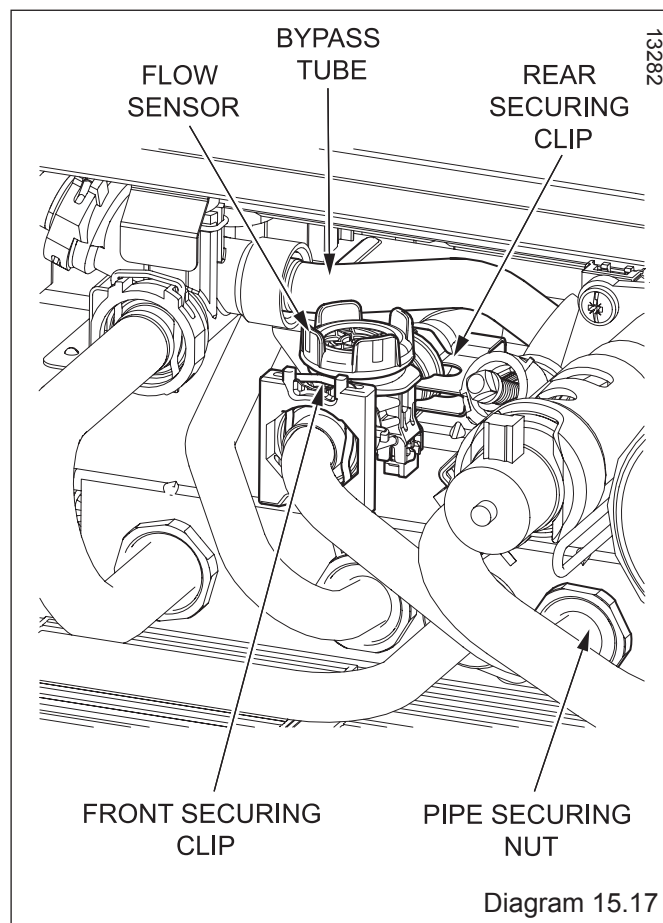

15 Replacement of Parts

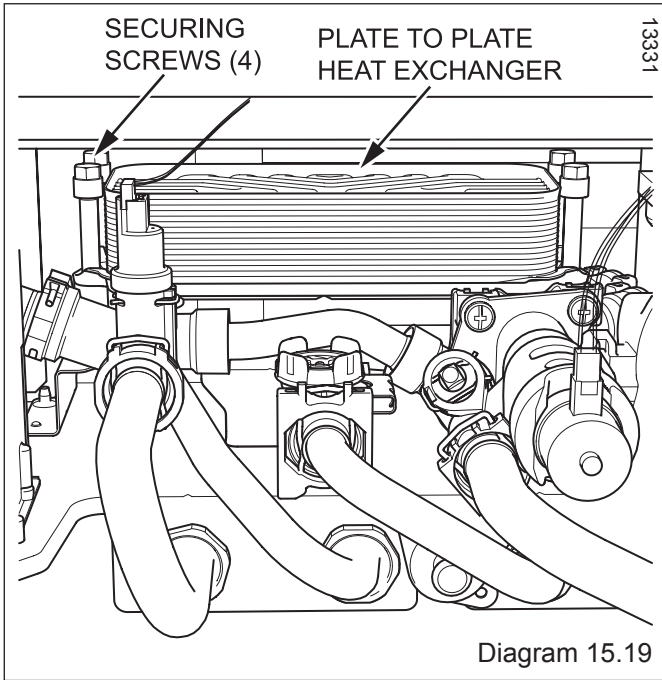

Diagram 15.19

15.26 Hydroblock and Bypass Tube

For access, refer to section 15.1.

IMPORTANT: To replace the bypass tube and seals the LH and RH hydroblocks will need to be removed. The following procedure must also be used for the replacement of either the LH or RH hydroblock.

Refer to section 15.1 and drain the boiler heating circuit and the boiler domestic water circuit.

Disconnect the CH flow, return and DHW inlet pipes at the bulkhead connectors, then the retaining clips, remove the pipes and "o" ring seals.

Remove the low water pressure sensor as described in section 15.21.

Remove the flow sensor as described in section 15.22.

Remove the 3 way valve as described in section 15.24.

Remove the pump as described in section 15.17.

Remove the plate to plate heat exchanger, refer to section 15.25.

Disconnect the central heating flow at the heat exchanger connector then remove the retaining clip at the hydroblock.

Disconnect the pipe and "O" ring.

Remove clips from the plastic LH and RH hydroblocks retaining the DHW, DCW and heating flow pipes, see diagram 15.20.

Remove the CH filter from the heating flow pipe port in the LH hydroblock. The filter is a push-fit in the hydroblock port.

Grip the LH and RH hydroblocks simultaneously and lift clear of the spigots on the mounting bracket.

NOTE: Before removing the bypass tube from the hydroblocks, take note of the tube position and orientation.

Fit the new bypass tube with new 'O' ring seals and re-assemble to hydroblocks.

Before refitting the plate to plate heat exchanger ensure that the four rubber seals are in place, two in the LH and two in the RH hydroblock.

Fit new 'O' rings to pipes.

Refill system, vent and pressurise the boiler.

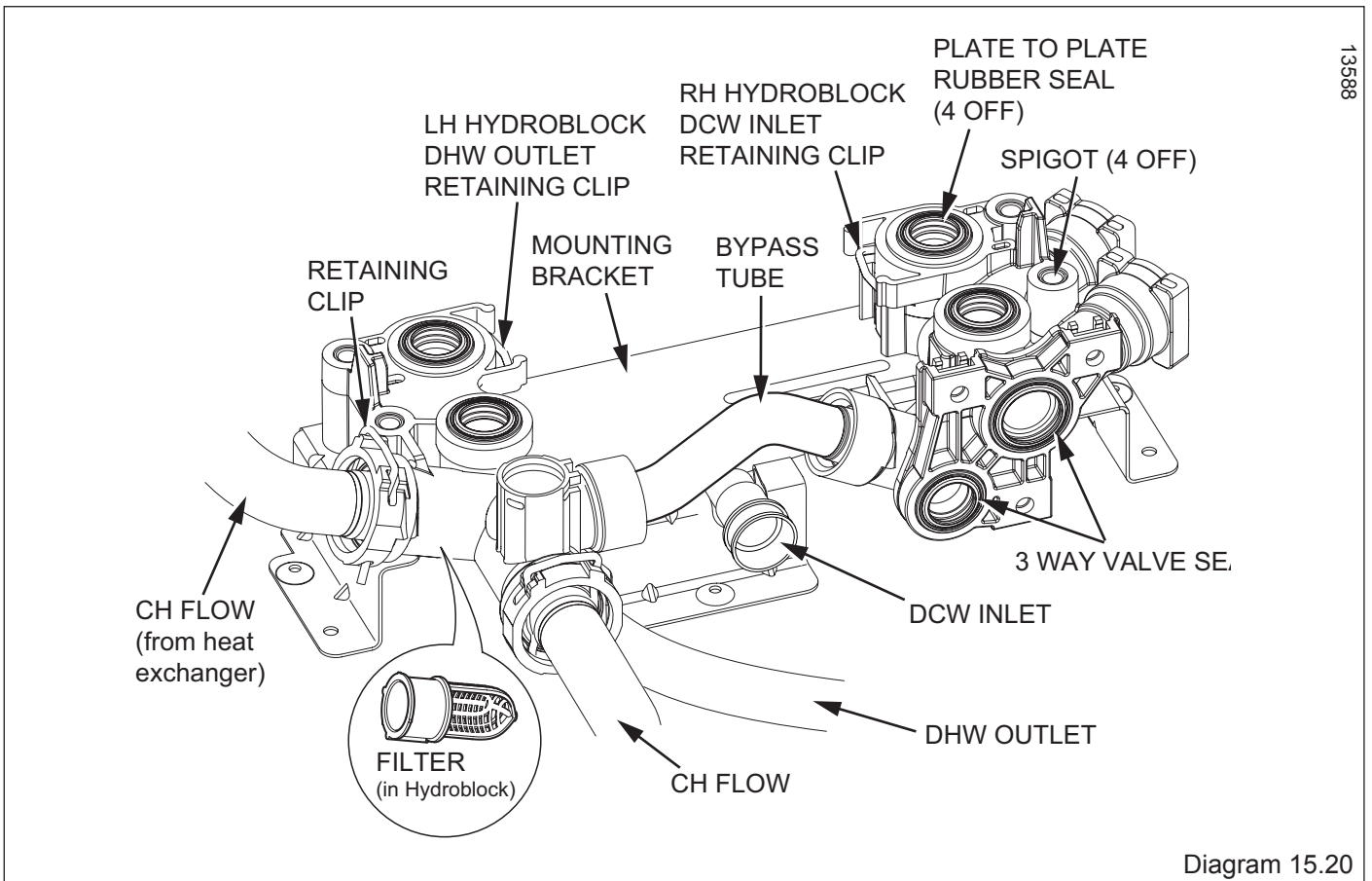

Diagram 15.20

15 Replacement of Parts

15.27 Appliance Interface and Main PCB

For access, refer to section 15.1.

Remove control box retaining screw, see diagram 15.21.

Hinge down the control box.

Release the control box cover by carefully pressing the four retaining latches, see diagram 15.21.

15.28 Main PCB

IMPORTANT: When replacing the board refer to instructions supplied with the replacement.

For access, refer to section 15.27.

Remove the electrical connections to the PCB.

Ease back the four PCB retaining clips and withdraw the PCB from the retaining lugs, see diagram 15.22.

When refitting the rear panel ensure the leads are not trapped.

When replacing the board refer to instructions supplied with the replacement.

15.29 Appliance Interface

IMPORTANT: When replacing the board refer to instructions supplied with the replacement.

Refer to section 15.27 for access.

Remove main PCB, refer to section 15.28.

Remove electrical connection.

Gently ease back the retaining clips, see diagram 15.23.

Withdraw the board.

15.30 Fuse, Main PCB - Control Box

For access, refer to section 15.27.

The fuse is located at top left hand side of the PCB, see diagram 15.22.

15.31 Control Box

For access, refer to section 15.27.

Remove relevant plugs and connectors, refer to wiring diagram 14.4.

Withdraw grommets and leads so they are hanging loose.

Unthread the retaining cord and remove the control box by drawing it outwards away from its retaining slots, see diagram 15.21.

15.32 Inner Casing Panel Seal

For access, refer to section 15.1.

Refer to diagram 13.8.

Remove the inner casing panel.

To replace remove the old seal, thoroughly clean the casing surfaces. Fit the new seal, it is supplied to the correct length.

Refit the inner casing panel.

NOTE: Ensure the seal is fitted correctly giving an airtight joint.

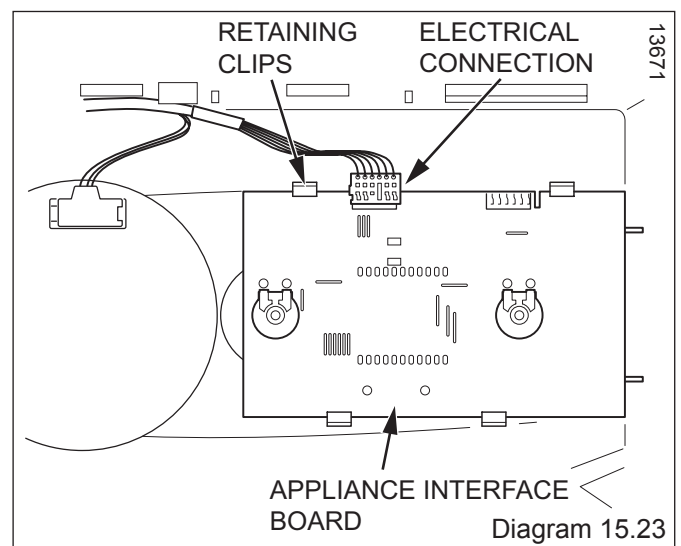
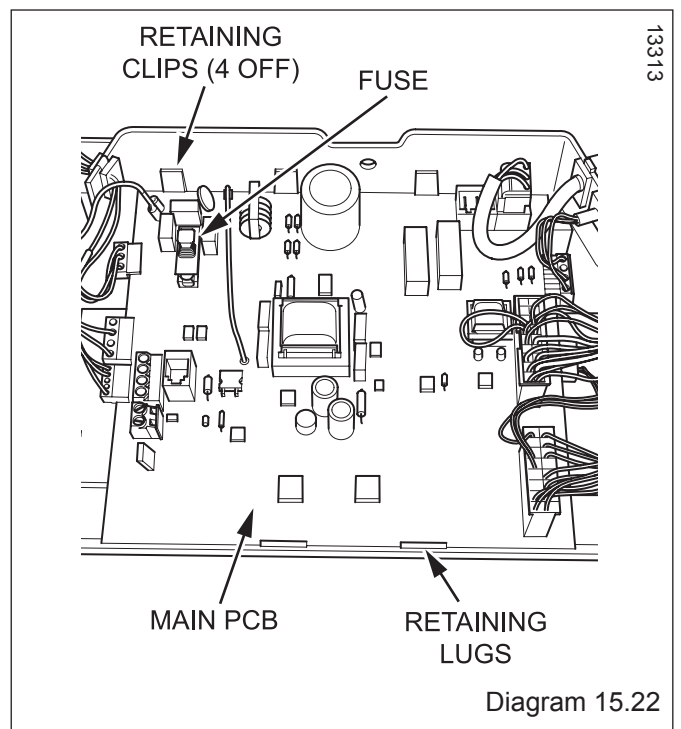
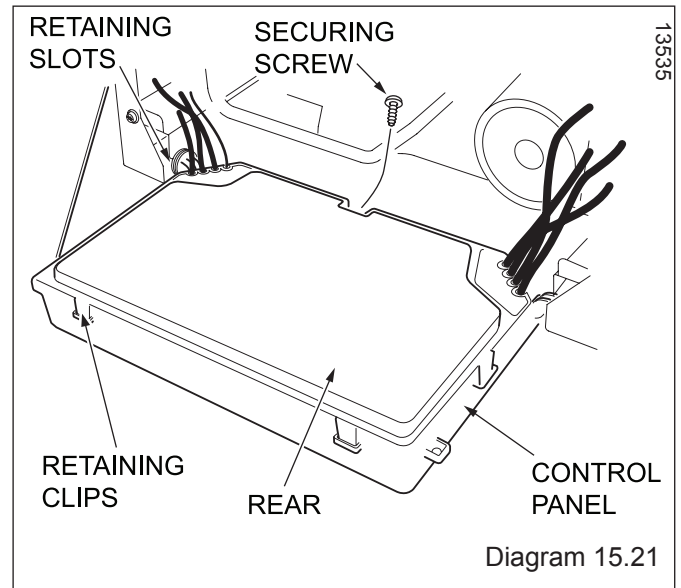

16 Spare Parts

16.1 Spare Parts

When ordering spare parts, contact Glow-worm's own service organisation using the telephone number on the inside front cover of this booklet. Please quote the name of the appliance and serial number, to be found on the data label. If ordering from British Gas also quote the G.C. number of the part.

Key No.	Part No.	Description	GC Part No.
1	2000802463	Burner - 24cx	E84021
1	2000801840	Burner - 30cx	E88867
2	0020014173	Pressure Relief Valve	H42758
3	0020014161	Automatic Air Vent	H42754
4	0020014171	Pump	H42760
5	801655	Igniter	E84015
6	0020038061	Appliance Interface	H52596
7	0020023825	Main PCB	H42783
8	0020037309	Fan	H53083
9	2000802664	Gas Valve	E84004
10	0020014174	Flow Sensor	H43155
11	0020014169	Bypass	H42768
12	0020014168	3 Way Valve	H42766
13	0020014160	Domestic Hot Water Thermistor	H36325
14	0020020781	NTC	720340
15	0020014402	Plate to Plate Heat Exchanger	H43160
16	2000802462	Electrode	H53089
17	801635	Burner Door Seal Kit	E85008

16 Spare Parts

13734

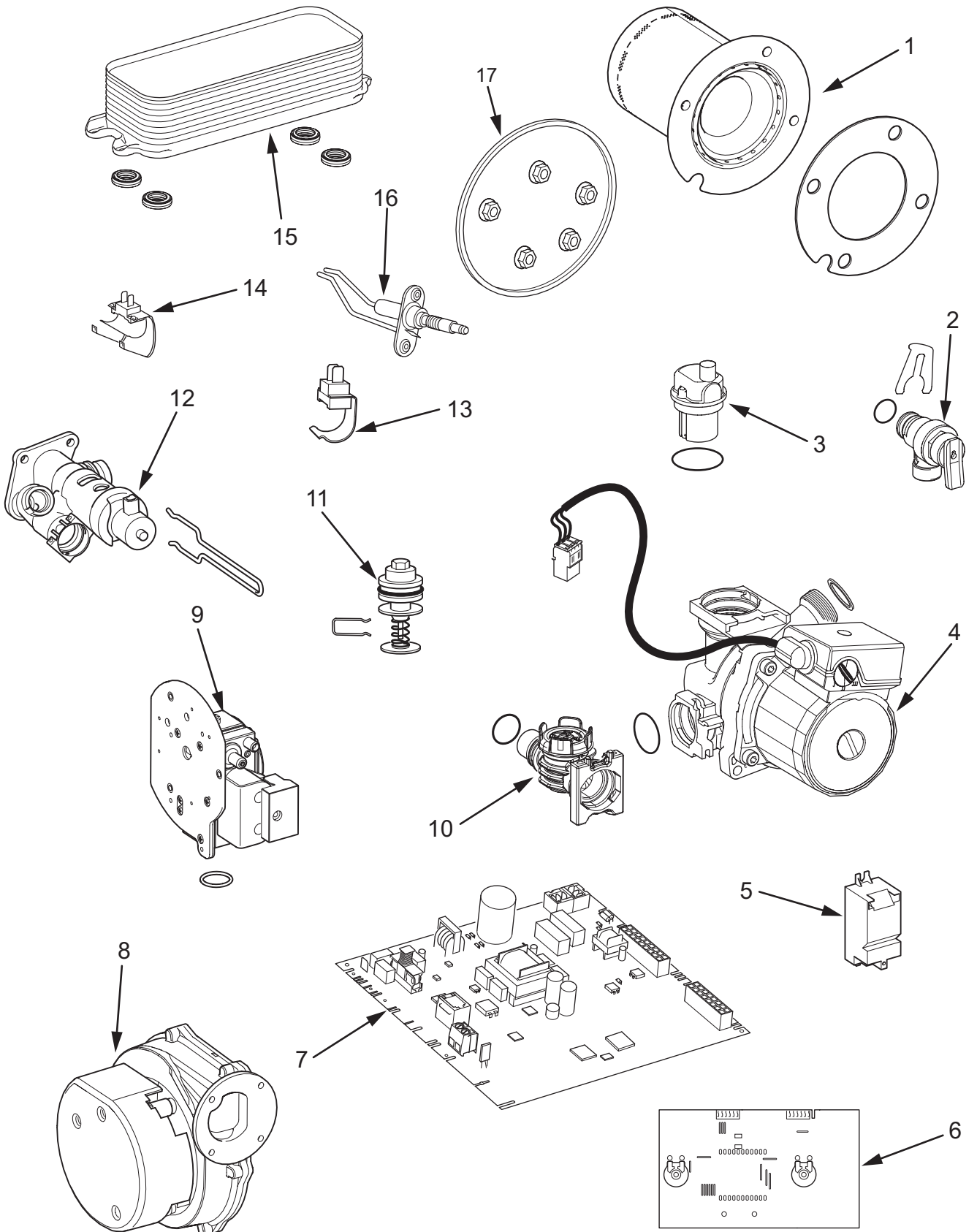

Diagram 16.1

17 Manual Handling

IMPORTANT. With regards to the Manual Handling Operations, 1992 Regulations, the following lift operation exceeds the recommended weight for a one man lift.

General recommendations when handling

Clear the route before attempting the lift.

Ensure safe lifting techniques are used – keep back straight – bend using legs. Keep load as close to body as possible. Do not twist – reposition feet instead. If 2 persons performing lift, ensure co-ordinated movements during lift. Avoid upper body/top heavy bending - do not lean forward/sideways. Recommend wear suitable cut resistant gloves with good grip to protect against sharp edges and ensure good grip.

Always use assistance if required.

Removal of carton from delivery van

Recommend 2 person lift or 1 person with use of sack truck. If 1 person is performing lift, straddle the load, tilt and place carton into position on truck. Recommend secure appliance onto truck with suitable straps. Ensure safe lifting techniques are used – keep back straight – bend using legs. Keep load as close to body as possible. If 2 persons performing lift, ensure co-ordinated movements during lift. Always use assistance if required.

Carriage of carton from point of delivery to point of installation – ground floor.

Recommend 2 person lift or 1 person with use of sack truck. If 1 person is performing lift, straddle the load, tilt and place carton into position on truck. Recommend secure appliance onto truck with suitable straps. Ensure safe lifting techniques are used – keep back straight – bend using legs. Keep load as close to body as possible. If 2 persons performing lift, ensure co-ordinated movements during lift. Clear the route before attempting the lift. If removing boiler from truck straddle the load and tilt forwards to facilitate secure grip. Ensure safe lifting techniques are used – keep back straight – bend using legs. Do not twist – reposition feet instead. Take care to avoid trip hazards, slippery or wet surfaces and when climbing steps and stairs. Always use assistance if required.

Carriage of carton from point of delivery to point of installation – first or higher floor, cellar.

Recommend 2-person lift or 1 person with use of sack truck. If 1 person is performing lift, straddle the load, tilt and place carton into position on truck. Recommend secure appliance onto truck with suitable straps. Ensure safe lifting techniques are used – keep back straight – bend using legs. Keep load as close to body as possible. If 2 persons performing lift, ensure co-ordinated movements during lift. Avoid upper body/top heavy bending - do not lean forward/sideways. Clear the route before attempting the lift. If removing boiler from truck straddle the load and tilt forwards to facilitate secure grip. Ensure safe lifting techniques are used – keep back straight – bend using legs. Do not twist – reposition feet instead. Take care to avoid trip hazards, slippery or wet surfaces and when climbing steps and stairs. Always use assistance if required.

Carriage of carton from point of delivery to point of installation – roofspace.

Recommend 2-person lift. Ensure co-ordinated movements during lift. Avoid upper body/top heavy bending - do not lean forward/sideways. Clear the route before attempting the lift. Take care to avoid trip hazards, slippery or wet surfaces and when climbing steps and stairs. When transferring appliance into roofspace, recommend 1 person to be in roofspace to receive the appliance and other person to be below to pass up and support appliance. Ensure safe lifting techniques are used – keep back straight – bend using legs. Keep load as close to body as possible. Always use assistance if required. It is assumed safe access, flooring and adequate lighting are provided in the roof space. It is recommended a risk assessment of the roof space area be carried out before moving the appliance into the area to take into account access, stability of flooring, lighting and other factors, and appropriate measures taken.

Unpacking of appliance from carton.

Recommend 2 persons unpack appliance from carton. Always keep working area clear. Cut the carton straps, lift carton up and slide over polystyrene end packs. Remove top polystyrene pack with fittings.

Positioning of Appliance for Final Installation – no obstructions.

Recommend 2 persons lift appliance to position into place. Fit bracket securely onto wall before lifting appliance into position. Obtain firm grip on front and sides of appliance, lift upwards, ensure stable balance achieved and lift upwards to position in place on bracket. Ensure safe lifting techniques are used – keep back straight – bend using legs - when lifting load from floor level. Do not twist – reposition feet instead. Keep boiler as close as possible to body throughout lift to minimise strain on back. Ensure co-ordinated movements to ensure equal spread of weight of load. Always use assistance if required. Recommend wear suitable cut resistant gloves with good grip to protect against sharp edges and ensure good grip when handling appliance.

Positioning of Appliance for Final Installation – above worktop, foreseeable obstructions etc.

Recommend 2 persons lift appliance to position into place. Fit bracket securely onto wall before lifting appliance into position. Obtain firm grip on front and sides of appliance, lift upwards, onto worktop if practicable. Ensure stable balance achieved and lift upwards to position in place on bracket. If 2 persons positioning onto bracket obtain firm grip at front and sides/base of boiler. Ensure co-ordinated movements during 2 person lifts to ensure equal spread of weight of load. Ensure safe lifting techniques are used – keep back straight – bend using legs - when lifting load from floor level. Do not twist – reposition feet instead. Keep boiler as close as possible to body throughout lift to minimise strain on back. Avoid upper body/top heavy bending - do not lean forward/sideways. Always use assistance if required. Recommend wear suitable cut resistant gloves with good grip to protect against sharp edges and ensure good grip when handling appliance.

Positioning of Appliance for Final Installation – within compartment etc. restricting installation.

Recommend 2 persons lift appliance to position into place, space permitting. Fit bracket securely onto wall before lifting appliance into position. Obtain firm grip on front and sides of appliance, lift upwards, onto worktop if practicable. Ensure stable balance achieved and lift upwards to drop into place onto bracket. If 2 persons positioning onto bracket obtain firm grip at front and sides/base of boiler. Ensure co-ordinated movements during 2 person lifts to ensure equal spread of weight of load. If 1 person positioning onto bracket recommend obtain firm grip supporting base of boiler. Ensure safe lifting techniques are used – keep back straight – bend using legs - when lifting load from floor level. Do not twist – reposition feet instead. Keep boiler as close as possible to body throughout lift to minimise strain on back. Always use assistance if required. Recommend wear suitable cut resistant gloves with good grip to protect against sharp edges and ensure good grip when handling appliance.

Positioning of Appliance for Final Installation – in roof space restricting installation.

Recommend 2 persons lift appliance to position into place, space permitting. Fit bracket securely onto wall before lifting appliance into position. Obtain firm grip on front and sides of appliance, lift upwards, ensure stable balance achieved and lift upwards to drop into place onto bracket. If 2 persons positioning onto bracket obtain firm grip at front and sides/base of boiler. Ensure co-ordinated movements during 2 person lifts to ensure equal spread of weight of load. If 1 person positioning onto bracket recommend obtain firm grip supporting base of boiler. Ensure safe lifting techniques are used - keep back straight – bend using legs - when lifting load from floor level. Do not twist – reposition feet instead. Keep boiler as close as possible to body throughout lift to minimise strain on back. Always use assistance if required. Recommend wear suitable cut resistant gloves with good grip to protect against sharp edges and ensure good grip when handling appliance. It is recommended a risk assessment of the roof space area be carried out before moving the appliance into the area to take into account access, stability of flooring, lighting and other factors, and appropriate measures taken.

EC declaration of conformity

Name and Address of the manufacturer: Glow-worm
Nottingham Road
Belper
Derbyshire DE56 1JT

Identification of product: Glow worm :- Ultracom Series Condensing Wall Hung Combination Boilers

Appliance type: Ultracom 24cx & 30cx

The appliance types satisfy the essential requirements of the relevant directives and Standards:

90/396/EEC including amendments "Directive on the approximation of the law of the member states relating to appliances burning gaseous fuels"	Designed and built to CE-type examination certificate: PIN no: 87BO41
92/42/EEC including amendments "Directive of efficiency relating to boiler burning gaseous fuels"	Designed and built according to European Standards:
73/23/EEC including amendments "Directive on the harmonization of the laws of Member States relating to electrical equipment designed for use within certain voltage limits"	EN 483 EN 677 EN 625 EN 60335-1 EN 60529
89/336/EEC including amendments "Directive on the approximation of the law of the member states relating to electromagnetic compatibility"	EN 50165 EN 55014 EN 61000-3-2 EN 61000-3-3

Any change to the appliance and/or any use not according to the instructions will lead to the invalidation of this Declaration of Conformity

Belper, January 2007

(place, date)



Program Manager
S. Keeton



Certification Manager
A. Beardsley

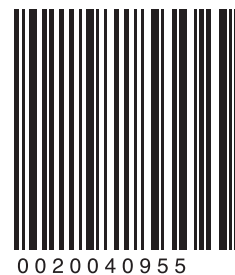

0020040955-04 09.09

Because of our constant endeavour for improvement, details may vary slightly from those shown in these instructions.

Glow-worm, Nottingham Road, Belper, Derbyshire. DE56 1JT