

Glow worm

Instructions for Use Installation and Servicing

To be left with the user

Ultimate

50BF

G.C. No. 41 319 53

Balanced Flue Boiler



BS 6332
BS 5258

This is a Cat I_{2H} Appliance

Reference in these instructions to British Standards and Statutory Regulations/Requirements apply only to the United Kingdom.

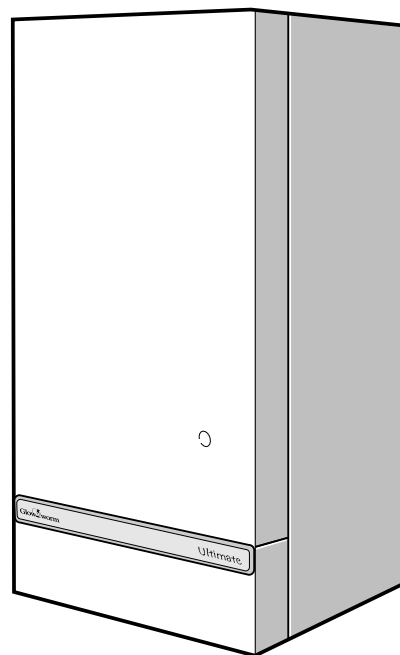

3790

The instructions consist of three parts, User, Installation and Servicing Instructions, which includes the Guarantee Registration Card. The instructions are an integral part of the appliance and must, to comply with the current issue of the Gas Safety (Installation and Use) Regulations, be handed to the user on completion of the installation.

Guarantee Registration

Thank you for installing a new Glow-worm appliance in your home.

Glow-worm appliances' are manufactured to the very highest standard so we are pleased to offer our customers' a Comprehensive First Year Guarantee.

Attached to the centre of these instructions is your Guarantee Registration Card, which we recommend you complete and return as soon as possible.

If this card is missing you can obtain a copy or record your registration by telephoning the Heatcall Customer Service number 01773 828100.

Our Guarantee gives you peace of mind plus valuable protection against breakdown by covering the cost of:

- All replacement parts**
- All labour charges**
- All call-out charges**

REGISTER YOUR GLOW-WORM APPLIANCE
FOR 1ST YEAR GUARANTEE PROTECTION

CALL 0208 247 9857

HEATCALL

Customer Services:

Tel: (01773) 828100

One Contact Local Service Fax: (01773) 828070

Hepworth Heating Ltd.,

Nottingham Road, Belper, Derbyshire. DE56 1JT

General/Sales enquiries:

Tel: (01773) 824141 Fax: (01773) 820569

Important Information

Testing and Certification

This boiler is tested and certificated for safety and performance. It is therefore important that no alteration is made to the boiler, without permission, in writing, from Hepworth Heating Ltd.

Any alteration not approved by Hepworth Heating Ltd., could invalidate the certification, boiler warranty and may also infringe the current issue of the Statutory Requirements, see Section 1.4.

CE Mark

This boiler meets the requirements of Statutory Instrument No. 3083 The boiler (Efficiency) Regulations, and therefore is deemed to meet the requirements of Directive 92/42/EEC on the efficiency requirements for new hot water boilers fired with liquid or gaseous fuels.

Type test for purposes of Regulation 5 certified by: Notified body 0086.

Product/productioncertifiedby: Notified body 0086.

The CE mark on this appliance shows compliance with:

1. Directive 90/396/EEC on the approximation of the laws of the Member States relating to appliances burning gaseous fuels.
2. Directive 73/23/EEC on the harmonization of the Laws of the Member States relating to the electrical equipment designed for use within certain voltage limits.
3. Directive 89/336/EEC on the approximation of the Laws of the Member States relating to electromagnetic compatibility.

INFORMATION FOR THE INSTALLER AND SERVICE ENGINEER.

Under Section 6 of The Health and Safety at Work Act 1974, we are required to provide information on substances hazardous to health.

CERAMIC FIBRE/INSULATION PADS, GLASSYARN.

These can cause irritation to skin, eyes and the respiratory tract. If you have a history of skin complaint you may be susceptible to irritation. High dust levels are usual only if the material is broken. Normal handling should not cause discomfort, but follow normal good hygiene and wash your hands before eating, drinking or going to the lavatory. If you do suffer irritation of the eyes or severe irritation to the skin seek medical attention.

CONTROL THERMOSTATS

These contain very small amounts of dichlorotrifluoroethane in the sealed phial and capillary. If broken, under normal circumstances the fluid does not cause a problem, but in case of skin contact, wash with cold water. If swallowed drink plenty of water and seek medical attention.

CONTENTS	DESCRIPTION	SECTION	PAGE No.
INSTRUCTIONS FOR USE	Introduction		3
	Lighting the Boiler		4
INSTALLATION INSTRUCTIONS	General Data	1	5
	Flue & Ventilation	2	7
	Water Systems	3	9
	Flue and Appliance Preparation	4	11
	Boiler Installation	5	13
	Commissioning	6	17
	Instructions to User	7	18
SERVICING INSTRUCTIONS	Servicing	8	19
	Fault Finding	9	21
	Replacement Parts	10	24
	Spare Parts	11	27

Instructions for Use

Introduction

Please read these instructions and follow them carefully for the safe and economical use of your boiler.

The Ultimate BF series are central heating boilers designed to provide heating and indirect domestic hot water.

Important Notice

This boiler is for use only on G20 gas.

The Gas Safety (Installation and Use) Regulations

In your interest and that of gas safety it is the Law that ALL gas appliances are installed by a competent person in accordance with the current issue of these amended regulations.

Gas Leak or Fault

If a gas leak or fault exists or is suspected, the BOILER MUST BE TURNED OFF, including the electrical supply and MUST NOT BE USED UNTIL THE FAULT HAS BEEN PUT RIGHT. Advice/help should be obtained from your installation/servicing company or the local gas undertaking.

Maintenance

To ensure the continued efficient and safe operation of the boiler it is recommended that it is checked and serviced as necessary at regular intervals. The frequency of servicing will depend upon the particular installation conditions and usage, but in general once a year should be enough.

If this appliance is installed in a rented property there is a duty of care imposed on the owner of the property by the current issue of the Gas Safety (Installation and Use) Regulations, Section 35.

It is the Law that any servicing be carried out by a competent person.

To obtain service, please call your installer or Heatcall (Glow-worm's own service organisation) using the telephone number given on the controls tray.

Please be advised that the 'Benchmark' logbook should be completed by the installation engineer on completion of commissioning and servicing.

All CORGI Registered Installers carry a CORGI ID card, and have a registration number. Both should be recorded in your boiler Logbook. You can check your installer is CORGI registered by calling CORGI direct on :- 01256 372300.

Cleaning

WARNING. This boiler contains metal parts (components) and care should be taken when handling and cleaning, with particular regard to edges.

Clean the casing occasionally by wiping it over with a damp soapy cloth or dry polishing duster.

Do not use an abrasive cleaner.

Protection Against Freezing

If the boiler is to be out of use for any long period of time during severe weather conditions we recommend that the whole of the system, including the boiler, be drained off to avoid the risk of freezing up. Make sure that, if fitted, the immersion heater in the indirect cylinder is switched off.

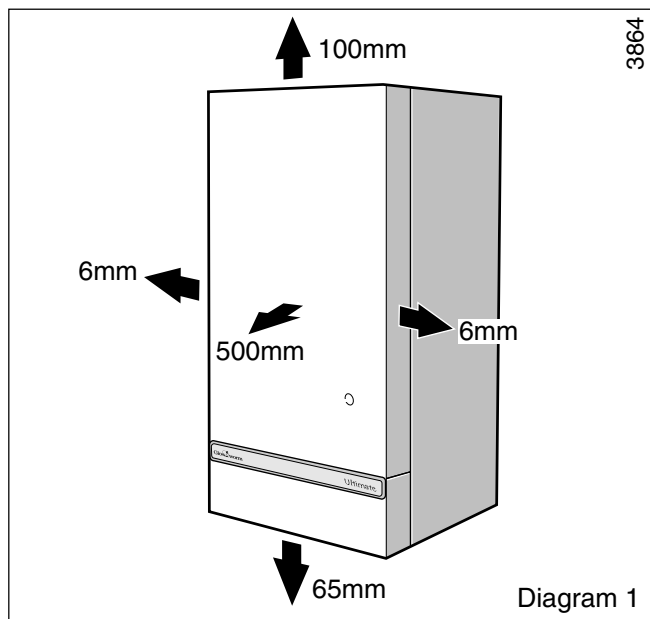

Data Label

The serial number and GC number of the boiler can be found on the Data Label, see diagram 2.

Boiler Clearances

If fixtures are positioned close to the boiler space must be left as shown in diagram 1. Enough space must also be left in front of the boiler to allow for servicing.

Boilers Installed in a Compartment or Cupboard

If the boiler is installed in a compartment or cupboard do not obstruct any ventilation openings.

Do not use the compartment or cupboard for storage.

Boiler Electrical Supply

WARNING. This boiler must be earthed.

The boiler must only be connected to a 230V~50Hz supply protected by a 3A fuse.

All wiring must be in accordance with the current issue of BS7671.

Wiring to the boiler must be PVC insulated type to the current issue of BS6500 Table 16, not less than 0.75mm² (24/0.20mm).

The colours of 3 core flexible cable are:-

Brown - live, Blue - neutral, Green and yellow - earth.

As the markings on your plug may not correspond with these colours, continue as follows:-

The wire coloured blue must be connected to the terminal marked "N" or "Black".

The wire coloured brown must be connected to the terminal marked "L" or "Red".

The wire coloured green and yellow must be connected to the terminal marked "E", "Earth", "Green" or the earth symbol \perp .

Instructions for Use

To Light The Boiler

WARNING. If the pilot flame goes out, either intentionally or by accident, no attempt should be made to relight it for at least three minutes.

Identify the controls by reference to the diagram 2.

Switch off the electrical supply to the boiler.

Turn the control thermostat knob "B" fully anti-clockwise to the "O", Off position.

Push in control button "D", keep pressed in and at the same time operate the piezo button "A" until the pilot lights, look through viewing window "E". After the pilot lights keep the control button "D" pushed in for 20 seconds. If the pilot fails to stay alight a safety device prevents immediate relighting.

Do not attempt to relight until the safety device has reset, that is, for at least three minutes.

Switch on the electrical supply and check that all external controls are calling for heat.

Turn the control thermostat knob "B" clockwise to any position between "MIN" and "MAX" and the burner will light.

The maximum setting is about 82°C (180°F).

The above sequence must be repeated every time that the burner has to be relit.

To Turn the Boiler Off

For short periods, turn the control thermostat knob "B" fully anti-clockwise to "O" Off. To relight, turn control thermostat knob clockwise to any position between "MIN" and "MAX".

For longer periods, turn the control thermostat knob "B" fully anti-clockwise to "O" Off and slide multi-functional control button "D" to the left, it will automatically reset. Switch off the electrical supply to the boiler.

To relight, follow the full lighting sequence given above.

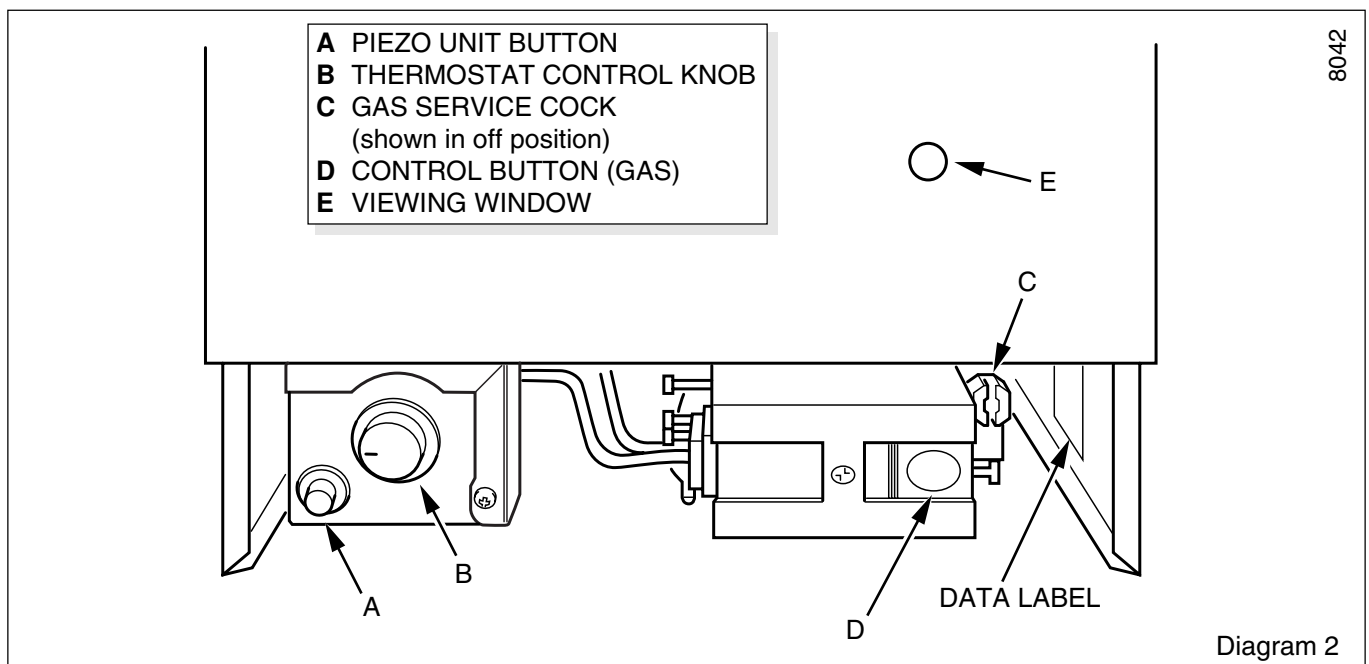

1 General Data

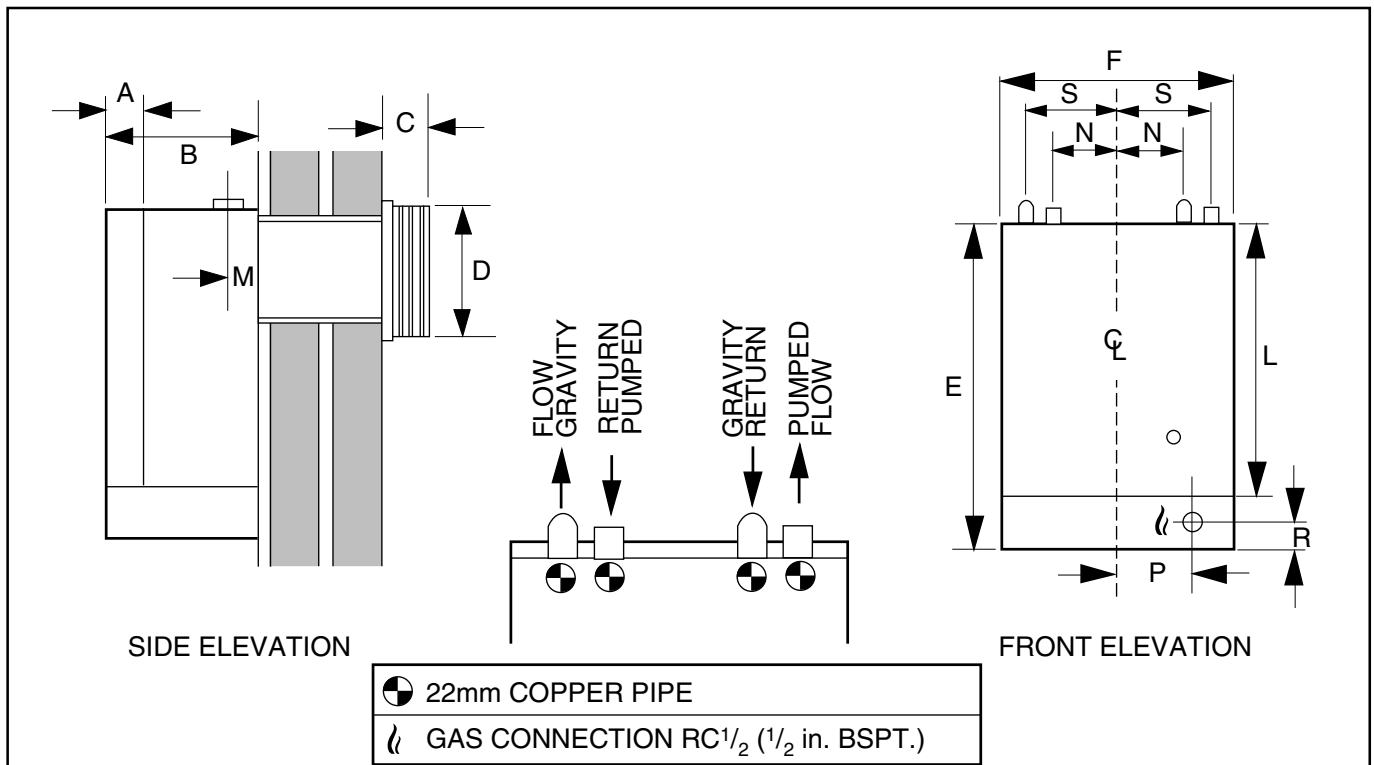

OVERALL DIMENSIONS (given in millimetres)

Diagram 1.1

MODELS	A	B	C	D	E	F	L	M	N	P	R	S
50BF	75	297	132	398	700	360	574	35	87	131	60	146

Important Notice

This boiler is for use only on G20 gas.

All dimensions are given in millimetres (except as noted).

This boiler can be used only on an open vented system, with either gravity or pumped domestic hot water connections to the indirect cylinder.

Wherever possible, all materials, appliances and components used shall comply with the requirements of applicable British Standards.

Where no British Standard exists, materials and equipment should be fit for their purpose and of suitable quality and workmanship.

Sheet Metal Parts

WARNING. When installing or servicing this boiler care should be taken when handling sheet metal parts, to avoid any possibility of personal injury.

1.1 Statutory Requirements

The installation of the boiler must be carried out by a competent person in accordance with the relevant requirements of the current issue of:-

Manufacturer's instructions, supplied.

The Gas Safety (Installation and Use) Regulations, The Building Regulations, The Building Standards (Scotland) Regulations (applicable in Scotland), Local Water Company Bye-laws, The Health and Safety at Work Act, Control of Substances Hazardous to Health, The Electricity at Work Regulations and any local regulations which may apply.

Detailed recommendations are contained in the current issue of the following British Standards and Codes of Practice:-

BS6798, BS5440 Part 1 and 2, BS5546 Part 1, BS5449, BS6891, BS6700, BS7593, BS7478, BS7671.

Manufacturer's instructions must not be taken as overriding statutory requirements.

1.2 Data

See Table 1

1.3 Range Rating

This boiler is range rated and may be adjusted to suit individual system requirements.

Table 2 gives the ratings and settings.

The Seasonal Efficiency Domestic Boilers UK (SEDBUK) is 73%.

The value is used in the UK Government's Standard Assessment Procedure (SAP) for energy rating of dwellings. The test data from which it has been calculated have been certified by B.S.I.

1.4 B.S.I. Certification

This boiler is certificated to the current issue of British Standard 6332 Part 1, invoking the current issue of BS5258 Part 1 for performance and safety. It is, therefore, important that no alteration is made to this boiler without permission, in writing, from Hepworth Heating Ltd.

Any alteration that is not approved by Hepworth Heating Ltd., could invalidate the B.S.I. Certification of the boiler, warranty and could also infringe the current issue of the Statutory Requirements.

1 General Data

1.5 Gas Supply

The gas installation shall be in accordance with the current issue of BS6891.

The supply from the governed meter must be of adequate size to provide a steady inlet working pressure of 20mbar (8in wg) at the boiler.

On completion test the gas installation for soundness using the pressure drop method and suitable leak detection fluid, purge in accordance with the above standard.

1.6 Electrical Supply

WARNING. This boiler must be earthed.

All system components shall be of an approved type and shall comply with and be connected in accordance with the current issue of BS7671 and any applicable local regulations.

Connection of the boiler and system controls to the mains supply must be through a common isolator and must be fused 3A, maximum. This method of connection must be by a fused double pole isolating switch, with a minimum contact separation of 3mm on both poles. The switch should be readily accessible and preferably adjacent to the appliance. It should supply the appliance only and be easily identifiable as so doing.

Alternatively, an unswitched shuttered socket outlet and 3A fused 3 pin plug both to the current issue of BS1363 may be used, provided that they are not used in a room containing a bath or shower.

Wiring to the boiler must be PVC insulated type to the current issue of BS6500 Table 16, not less than 0.75mm² (24/0.20mm).

1.7 Contents of Packaging

There are two packs, one contains the boiler, refer to Section 4.1 for contents.

The other pack contains the balanced flue terminal assembly, wall duct and flue hood assembly.

Refer to Section 2.3 to check that the flue terminal assembly supplied is suitable.

1.8 Water System

This boiler shall only be used on an unrestricted open vented system with the water supply taken from a feed and expansion cistern having a head of 27m (90ft) maximum.

This boiler must not be connected to a sealed water system.

1.9 Drain

System

A draining tap must be provided at the lowest points of the system which will allow the entire system, boiler and hot water cylinder to be drained.

Draining taps should be to the current issue of BS2879.

Boiler

A draining point is fitted at the bottom right hand side of the heat exchanger. Cover controls to avoid water damage. If required remove the combustion chamber front cover to improve access.

DATA TABLE 1.

TOTAL DRY WEIGHT (Including Terminal)	47.5kg (105lb)
LIFT WEIGHT	37kg (82lb)
WATER CONTENT	2.95Litre (0.65gal)
GAS CONNECTION	Rc 1/2 in.
WATER CONNECTION	4 x 22mm copper pipes from top of case
ELECTRICITY SUPPLY	230V~50Hz, fused 3A.
DATA LABEL	Bottom right hand side of case

TABLE 2.

RANGE RATING	min	medium	max
NOMINAL HEAT INPUT (GROSS) <i>kW</i>	14.84	16.58	18.32
<i>Btu/h</i>	50,630	56,565	62,500
NOMINAL HEAT OUTPUT <i>kW</i>	11.72	13.19	14.65
<i>Btu/h</i>	40,000	45,000	50,000
BURNER SETTING PRESSURE <i>m bar</i>	7.5	9.8	12.3
<i>in.w.g</i>	3.0	3.9	4.9
APPROX GAS RATE <i>m³/h</i>	1.44	1.61	1.77
<i>ft³/h</i>	51	57	62.5
BURNER INJECTOR MARKING: 203096			
PILOT INJECTOR MARKING: 7215			

1.10 Safety Valve

A safety valve need not be fitted to an open vented system.

1.11 Location

This boiler is not suitable for outdoor installation.

This boiler may be installed in any room, although particular attention is drawn to the requirements of the current issue of BS7671 with respect to the installation of a boiler in a room containing a bath or shower. Any electrical switch or boiler control utilising mains electricity should be placed so that it cannot be touched by a person using the bath or shower. The electrical provisions of the Building Standards (Scotland) Regulations apply to such installations in Scotland.

The boiler must be mounted on a flat wall which is sufficiently robust to take its total weight.

1 General Data

1.12 Boiler Clearances

Refer to diagram 1.2.

This boiler must be positioned so that at least the minimum operational and servicing clearances are provided.

Additional clearances may be required for installation.

If fixtures are positioned next to the boiler they should be made removable for access to pipework.

Sufficient clearance must be left in front of the boiler for servicing.

1.13 Heating System Controls

The heating system should have installed: a programmer and room thermostat controlling the boiler.

Thermostatic radiator valves may be installed in addition to the room thermostat.

Note: For further information, see The Building Regulations 1991 - Conservation of fuel and power, 1995 edition - Appendix G, table 4b.

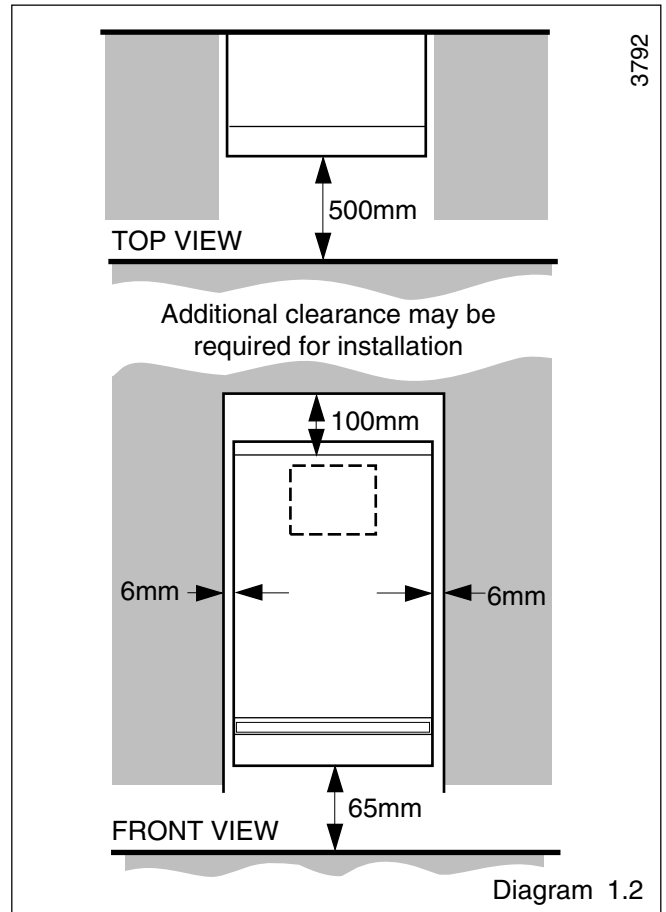

2 Flue and Ventilation

Note: Detailed recommendations for flues are given in the current issue of BS5440 Part 1.

2.1 Terminal Position

The minimum acceptable siting dimensions for the terminal from obstructions, other terminals and ventilation openings are shown in diagram 2.1.

The terminal must be exposed to the external air, the position allowing free passage of air across it at all times.

Car ports or similar extensions of a roof only, or a roof and one wall, require special consideration with respect to any openings, doors, vents or windows under the roof. Care is required to protect the roof if it is made of plastic sheeting. If the car port consists of a roof and two or more walls, seek advice from the local gas company before installing the boiler.

If the terminal is fitted within 600mm below plastic guttering or painted soffit an aluminium shield 1500mm long should be fitted immediately beneath the guttering or eaves. If the terminal is fitted within 450mm below painted eaves or a painted gutter, an aluminium shield 750mm long should be fitted immediately beneath the guttering or eaves.

2.2 Terminal Guard

A terminal guard is required if persons could come into contact with the terminal or the terminal could be subject to damage.

If a terminal guard is required, it must be positioned to provide a minimum of 50mm clearance from any part of the terminal and be central over the terminal.

A suitable guard, reference Type "F", can be bought from:-

Tower Flue Components Ltd
Morley Road
Tonbridge
Kent. TN9 1RA

2.3 Wall Thickness

Check the thickness of the wall.

Flues available are:-

Standard Pack:- 50BF Part No.446102

Extension Pack:- Part No.424680 plus

Standard Pack as above for 410 to 625mm (16 to 25in)

Note: If the wall thickness is less than 280mm the wall duct and flue ducts can be cut down, to a minimum length of 100mm.

2.4 Room Ventilation

The boiler is room sealed and does not require the room or space containing it to have permanent air vents.

2 Flue and Ventilation

2.5 Boilers in a Compartment

Where the installation of the boiler will be in an unusual position, special requirements are needed, the current issue of BS6798 gives detailed guidance on these requirements.

A compartment used to enclose the boiler must be designed and constructed specifically for this purpose. An existing cupboard or compartment modified for the purpose may be used. Details of essential requirements for cupboard or compartment design are given in the current issue of BS6798.

The doorway opening should be of sufficient size to allow for easy removal of the boiler.

Where the boiler is fitted in a cupboard or compartment, permanent high and low level ventilation must be provided. The minimum ventilation areas required are given in Table 3.

2.6 Timber Frame Building

If the boiler is to be installed in a timber frame building it should be fitted in accordance with the Institute of Gas Engineers document IGE/UP/7/1998. If in doubt seek advice from the local gas undertaking or Hepworth Heating Ltd.

COMPARTMENT AIR VENT TABLE				
COMPARTMENT VENTILATION REQUIREMENTS	HIGH LEVEL VENT AREA		LOW LEVEL VENT AREA	
	VENTILATION FROM ROOM OR SPACE	165cm ²	25in ²	165cm ²
FROM OUTSIDE	83cm ²	12.5in ²	83cm ²	12.5in ²

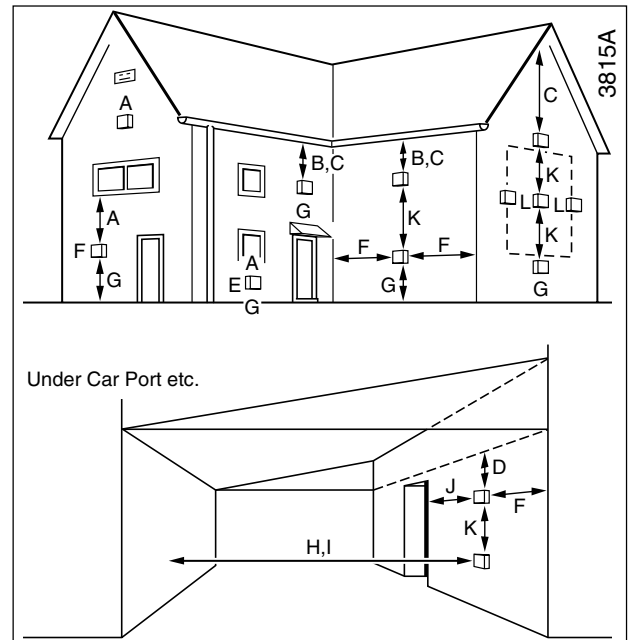

MINIMUM SITING DIMENSIONS FOR BALANCED FLUE TERMINALS

A	POSITION	MINIMUM SPACING (mm)
A	DIRECTLY BELOW AN OPENABLE WINDOW, AIR VENT, OR ANY OTHER VENTILATION OPENING	300
B	BELOW GUTTER, DRAIN/SOIL PIPE	300
C	BELOW EAVES	300
D	BELOW A BALCONY OR CAR PORT	600
E	FROM VERTICAL DRAIN PIPES AND SOIL PIPES	75
F	FROM INTERNAL OR EXTERNAL CORNERS	250
G	ABOVE ADJACENT GROUND OR BALCONY LEVEL	300
H	FROM A SURFACE FACING THE TERMINAL	600
I	FACING TERMINALS	600
J	FROM OPENING (DOOR/WINDOW) IN CAR PORT INTO DWELLING	1200
K	VERTICAL FROM A TERMINAL	1500
L	HORIZONTALLY FROM A TERMINAL	300

Diagram 2.1

3 Water Systems

The installation of the boiler must comply with the requirements of the current issue of BS6798.

3.1 Frost Protection

If the position of the boiler is such that it may be vulnerable to freezing it should be protected as specified in the current issue of BS5422. It is recommended that a frost protection thermostat be fitted.

3.2 Pump

The pump, with integral valves, should be fitted in the heating flow pipework from the boiler, it should be set to produce a temperature difference of 11°C (20°F), between the flow and return, with the control thermostat set at "MAX", which is about 82°C (180°F).

The resistance through the boiler can be found from diagram 3.1. High resistance microbore systems may require a higher duty pump.

3.3 Bypass - Fully Pumped Water System

A bypass is usually unnecessary on systems using a 3 port diverter valve since one port will remain in the open position at all times. This allows satisfactory operation of the pump overrun.

However if thermostatic radiator valves are fitted to all radiators or two port valves are used a bypass is required.

The bypass connection must be at least 2 metres away from the boiler.

The flow through the boiler must not be allowed to fall such that there is a temperature difference greater than 20°C between the flow and return.

3.4 Water System

The cold feed must be 15mm minimum size.

It is important that the relative positions of the pump, cold feed and open vent are as shown in diagram 3.2.

The unrestricted open vent from the boiler must rise continuously to discharge over the feed and expansion cistern.

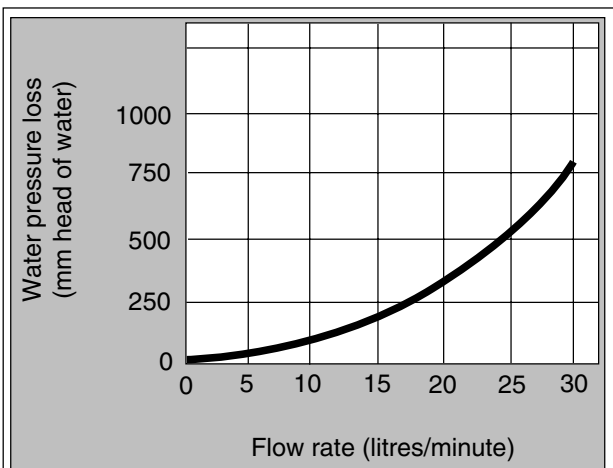
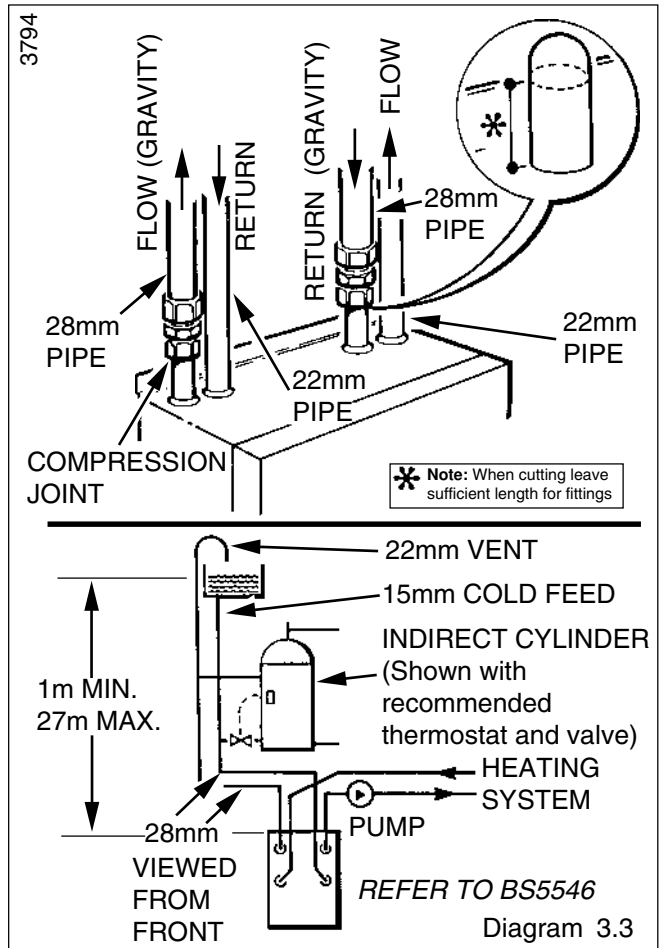
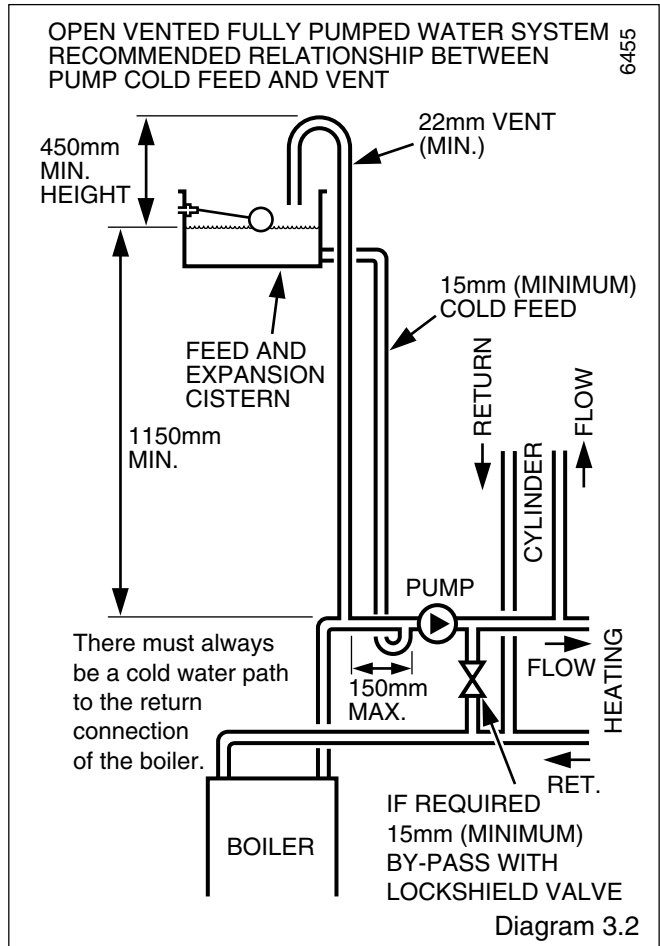

PRESSURE LOSS OF BOILER Diagram 3.1

3 Water Systems

3.5 Domestic Hot Water System

General. The domestic hot water service must be in accordance with the current issue of BS5546, refer also to the current issue of BS6700.

3.6 Indirect Cylinder

For all systems supplying domestic hot water the cylinder must be indirect. It is recommended that the indirect cylinder be fitted with some form of temperature control.

3.7 Gravity Domestic Hot Water with Pumped Heating

Important: If domestic hot water is to be provided by a gravity circulation to the indirect cylinder the blanked off connections must be opened and used, using 22x28mm connections, see diagram 3.3.

3.8 Fully Pumped Heating and Domestic Hot Water

The connections for this type of system MUST be as shown in diagram 3.2 and 3.4.

3.9 Inhibitor

Attention is drawn to the current issue of BS5449 and BS7593 on the use of inhibitors in central heating systems.

If an inhibitor is to be used, contact a manufacturer or Hepworth Heating Ltd., for their recommendations as to the best product to use.

When installing in an existing system take special care to drain the entire system, including radiators, then thoroughly cleaning out before installing the boiler whether or not adding an inhibitor.

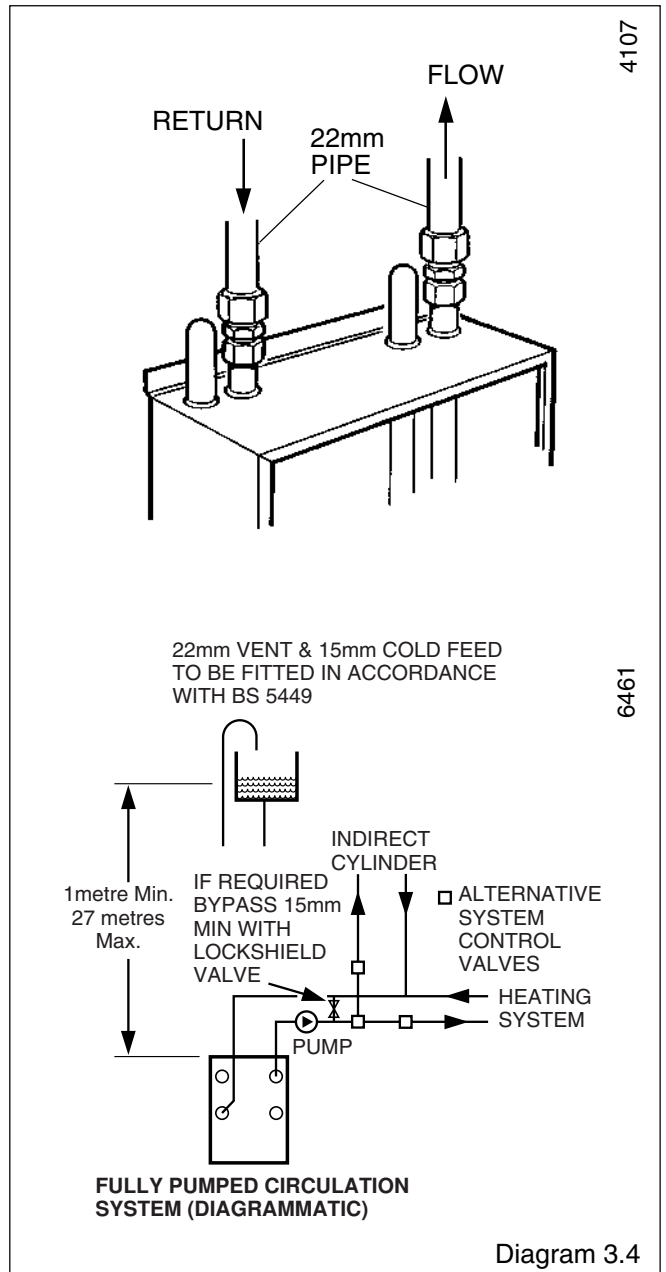

4 Flue and Appliance Preparation

4.1 Unpacking

Open the carton containing the boiler, remove the end fitting which contains, wall mounting bracket, heat exchanger baffles and loose items pack. Check the items supplied against the contents list on the flap and diagram 4.1.

With the boiler still in the bottom tray, slide the controls cover upward and remove it as shown in diagram 4.2. Remove the case by undoing the wing nuts and lifting the case off, see diagram 4.2.

Remove the packing piece from inside the case.

Place on one side until required.

Place the boiler on one side until required.

4.2 Positioning

Select the boiler position. Take due account of the position of the flue terminal, see diagram 2.1.

Use the template, making sure it is square and mark out the position of the flue opening, see diagram 4.3.

Cut a hole through the wall as neatly as possible.

Note. If the hole is oversize or of an irregular shape it must be faced off to the hole dimensions shown.

Use template, again, making sure that it is positioned both square and central to the flue hole, marking the fixing points at the top, bottom and clearance holes for wall duct.

Remove the wall template after marking, then check marked positions against diagram 4.3.

Drill holes to accept the plugs and screws supplied in the loose items pack.

Secure the bottom bracket to the wall, using the plugs and screws.

Make sure the bracket is level.

Drill a 7mm clearance hole to a depth of 10mm.

Fit plugs into top fixing holes and fit screws, leaving about 5mm proud.

Take the balanced flue assembly and wall duct from its carton, place the balanced flue assembly on one side until it is required.

Note. If fitting a short flue it will be necessary to cut wall duct, see Table 4.

Position the wall duct, see diagram 4.4.

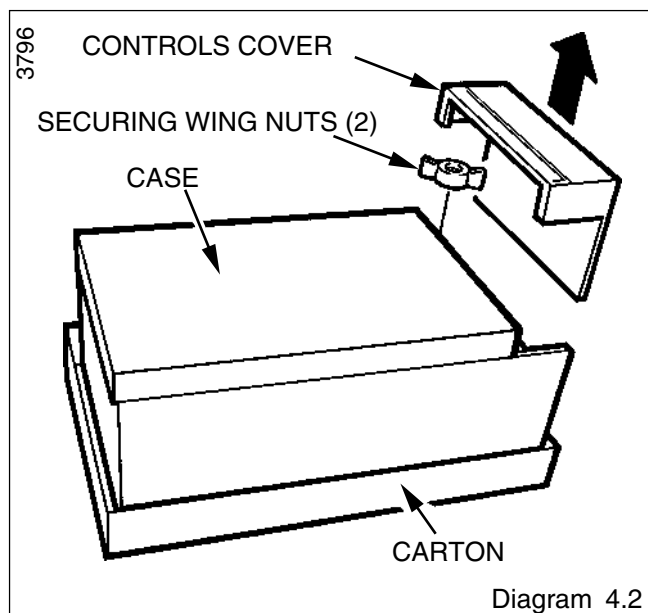
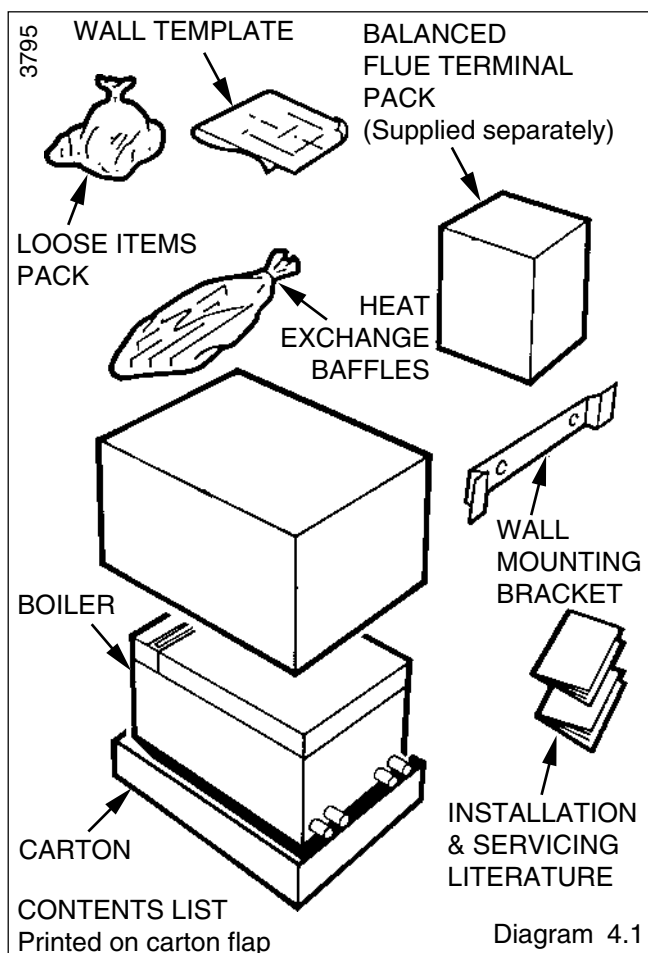

4 Flue and Appliance Preparation

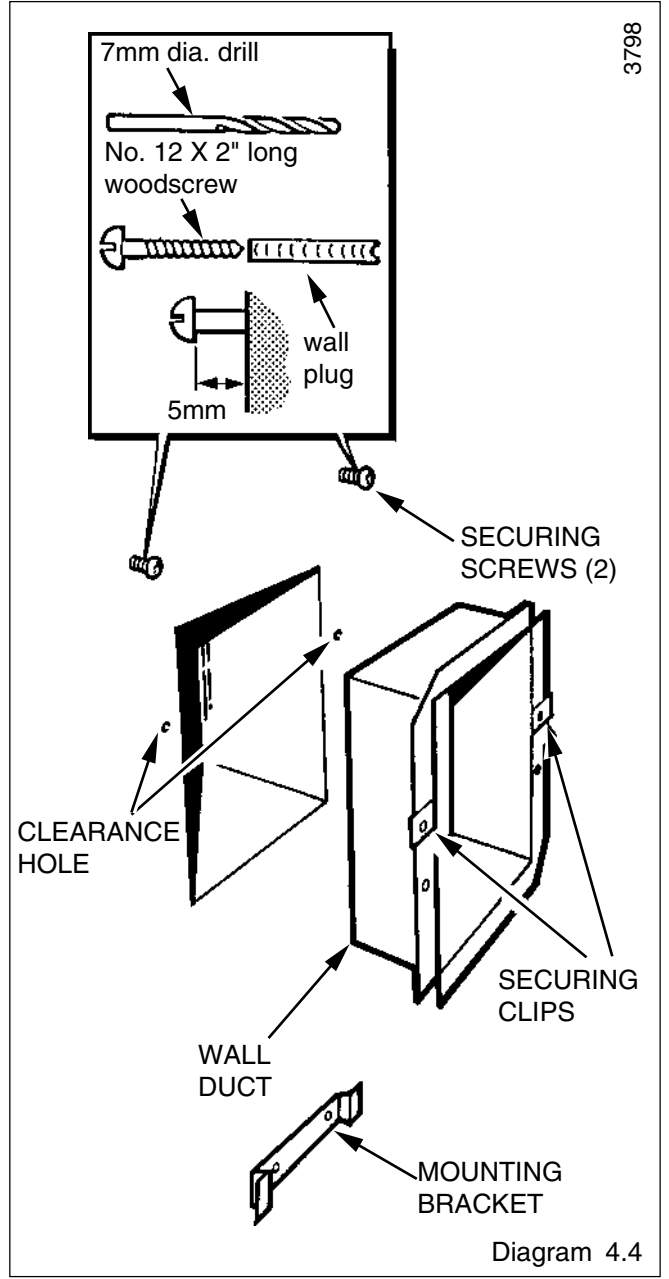
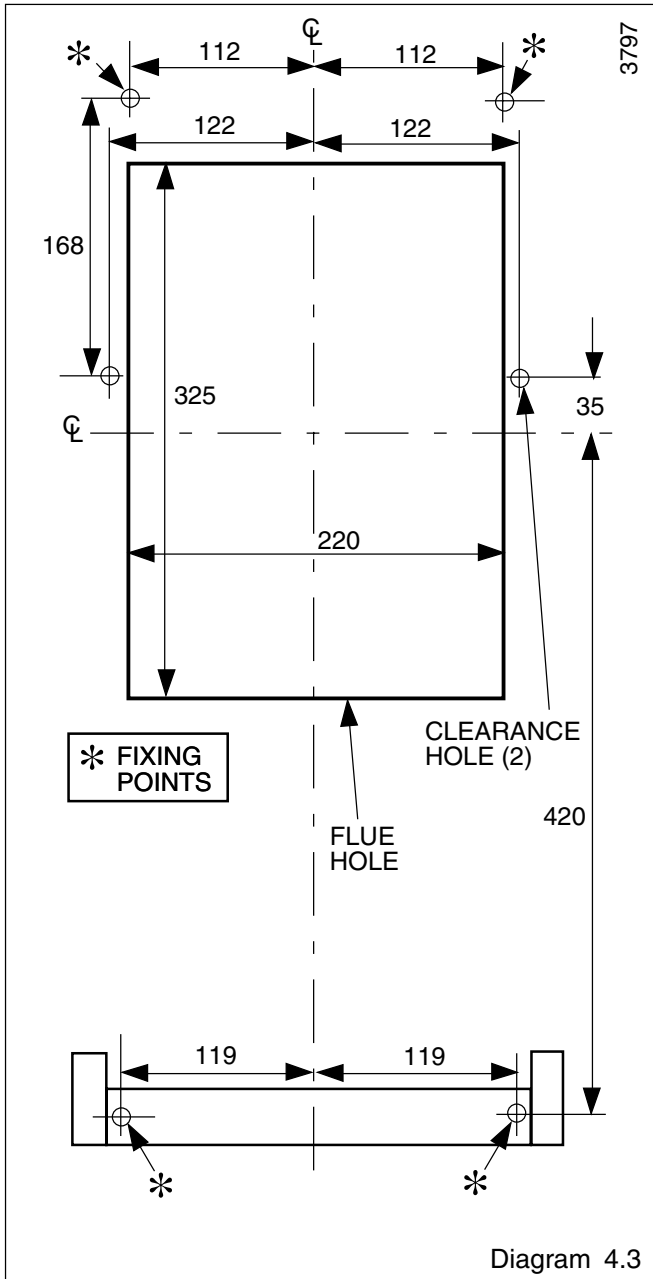

5 Boiler Installation

5.1 Mounting the Boiler

Remove the boiler from the carton tray.

If necessary, for a gravity domestic hot water system cut the pipes as shown in diagram 3.3.

Stand boiler upright on the packaging, to protect the paintwork.

Stick the foam seal around the boiler flange, at the back, making sure it is a tight fit, around the corners, see diagram 5.1.

Fit suitable fittings to the pipework.

Now make sure that the top, swing brackets are UPRIGHT, see diagram 5.2.

Lift the boiler into position, hooking over the bottom wall bracket.

Swing the brackets over the two screws at the top and secure, see diagram 5.2.

Secure the boiler to the flange on the wall duct, see diagram 5.3.

Note. For a short flue it will be necessary to cut the balanced flue assembly, see Table 4.

Take the balanced flue assembly from its carton and remove the four screws to release the outer baffle, wire guards and inner baffle flue duct assembly, from the air duct assembly, see diagram 5.4.

From the outside place the air duct assembly into the hole in the wall, fit it around the wall duct, slide in until the wall plate touches the wall surface. Make sure the air duct wire guards are in position.

Seal the joint in the air ducts with the yellow tape provided. Tape four pieces into the four inside corners, followed by four along the joints overlapping the corner pieces, to make a good seal, see diagram 5.4A. Allow a minimum of 20mm ($\frac{3}{4}$ in) overlap of the ductings.

Take the flue hood assembly, remove the access door, secure the assembly to the boiler, with the screws provided in the loose items pack, see diagram 5.5.

Place the inner baffle and flue duct assembly into the hole in the wall outside, fit it around the flue duct on the boiler and slide it in until it touches the air duct assembly wire guards.

Seal the flue duct joint on the inside with the heat resistant semi-transparent tape provided, see diagram 5.4A.

Cement around the wall plate.

To complete the flue terminal assembly, refit wire guards, outer baffle and secure with screws.

Fit the boiler flue baffles, see diagram 5.6.

Refit the flue access door.

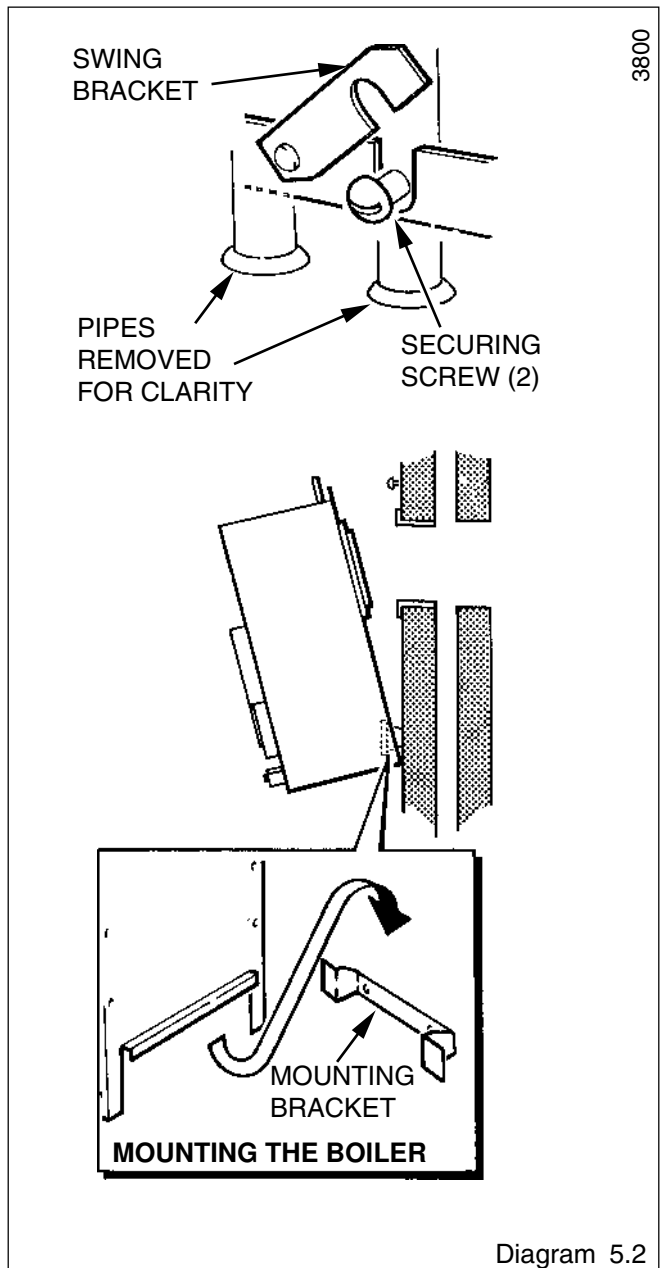
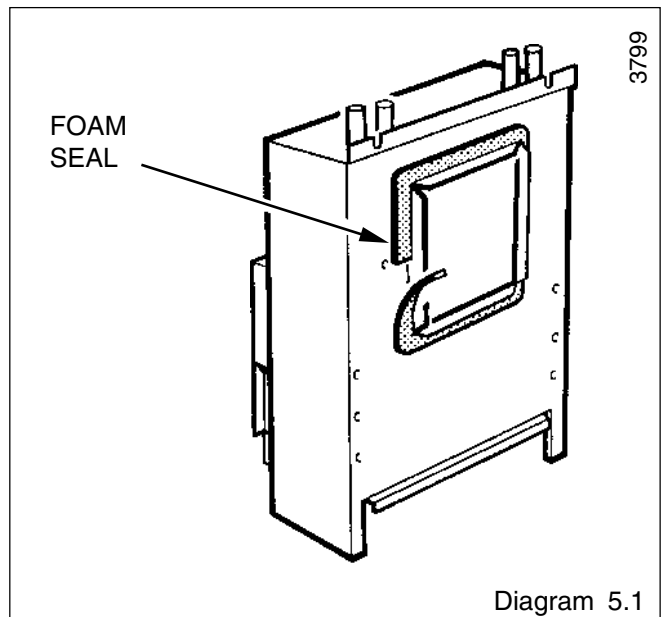

5 Boiler Installation

5.2 Water Circulation System

Complete the water connections to the boiler.

Fill, vent and cold flush the system as recommended in the current issue of BS6798.

Check for any water leaks and put right.

5.3 Gas Connection

Make the gas connection to the Rc $\frac{1}{2}$ in gas service cock.

Check for leaks using a suitable leak detection fluid.

TABLE 4. SHORT FLUE 100-280 CUTTING LENGTHS				
WALL THICKNESS	AIR DUCT		FLUE DUCT	
	Wall Duct	Air Duct	Flue Duct	Inner Baffle Flue Duct
100-150	70	190	190	70
150-200	20	190	190	20
200-280	0	130	130	0

5.4 Control Box

Remove the electrical control box securing screw, see diagram 5.7. Pull the control box down at the front and support on the hook at the rear of the control box cover, see diagram 5.8.

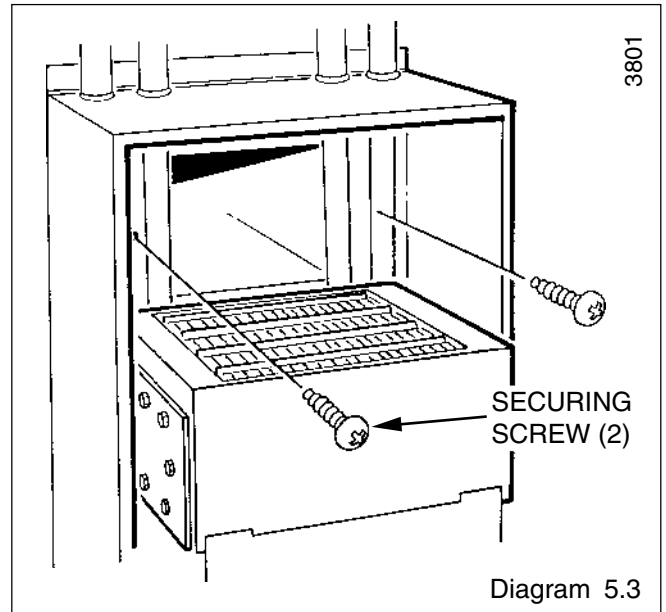

Diagram 5.3

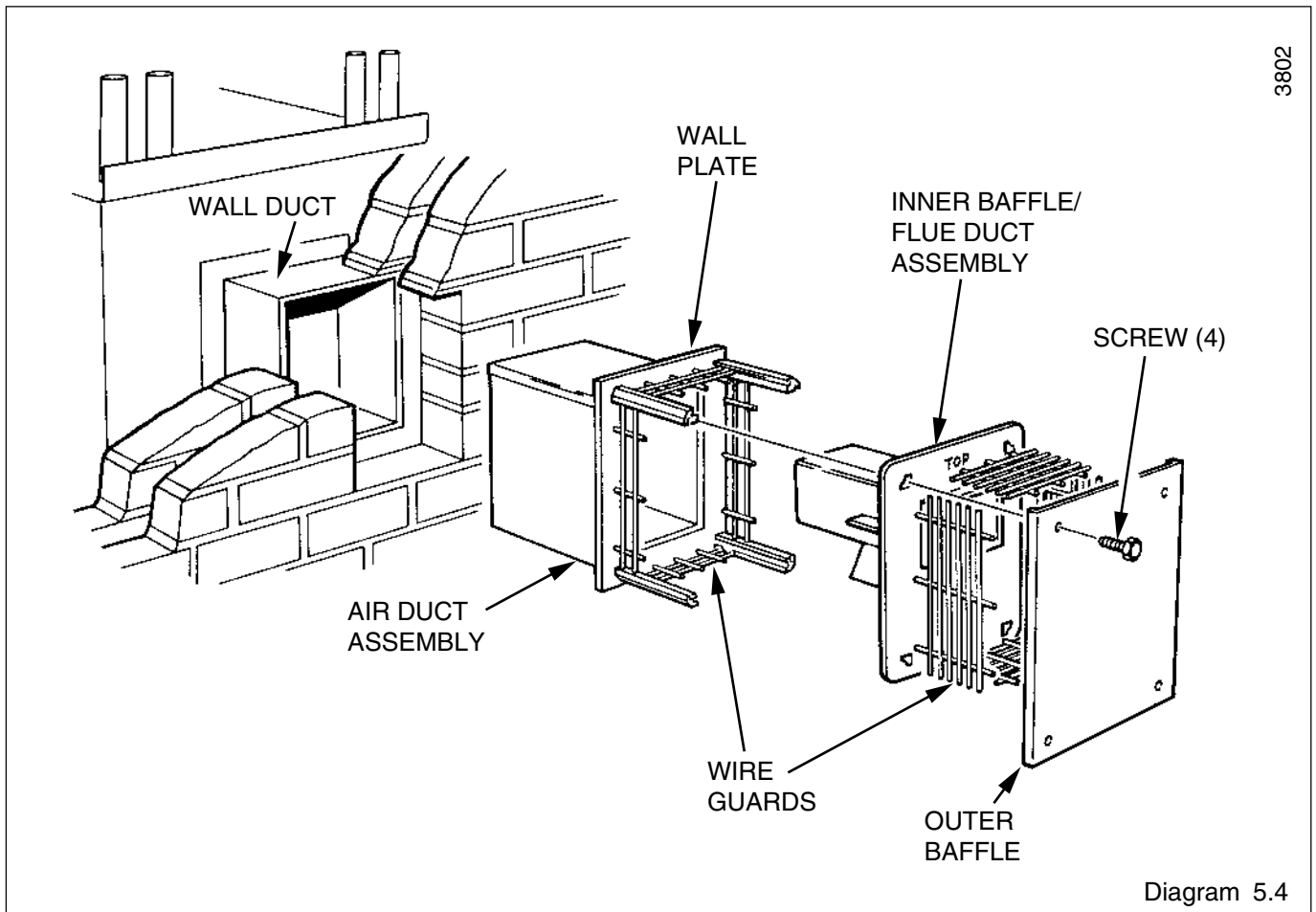

Diagram 5.4

5 Boiler Installation

5.5 Electrical Connection

Thread the mains cable through the cable clamp in the rear of the box and connect to the terminal strip, see diagram 5.8 and 5.9.

Standard colours are, brown - live (L), blue - neutral (N) and green and yellow - earth (E).

The mains cable outer insulation must not be cut back external to the cable clamp.

Make sure the cable is suitably secured.

When making connections, make sure that the earth conductor is made of a greater length than the current carrying conductors, so that if the cable is strained the earth conductor would be the last to become disconnected.

5.6 Testing

Checks to ensure electrical safety must be carried out by a competent person.

After installation of the system, preliminary electrical system checks as below should be carried out:

1. Test insulation resistance to earth.
2. Test earth continuity and short circuit of all cables.
3. Test the polarity of the mains.

Refit the control box.

The installer is requested to advise and give guidance to the user of the controls scheme used with the boiler.

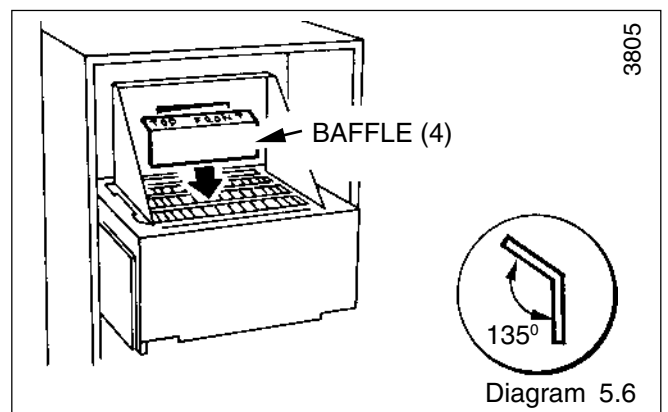
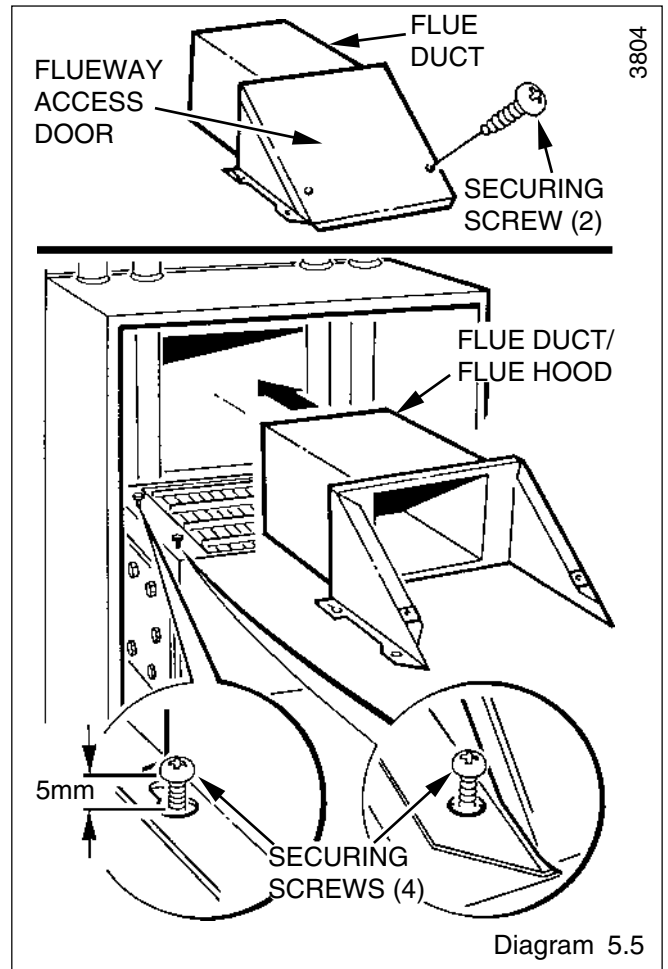
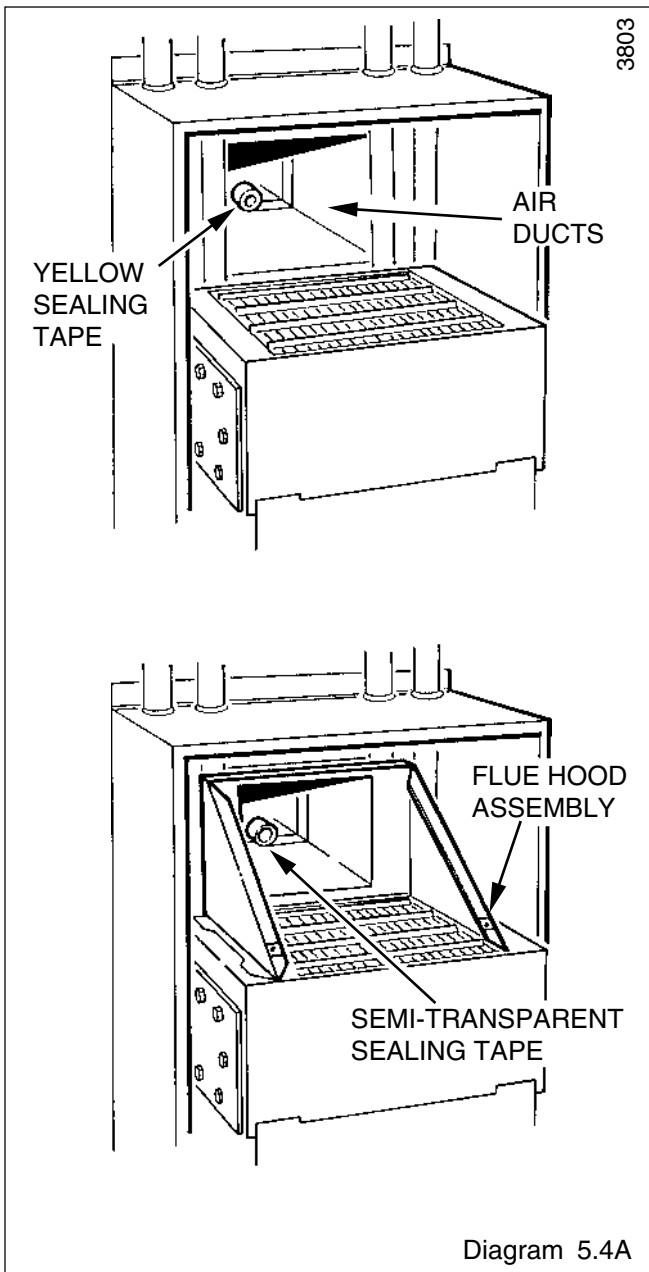

5 Boiler Installation

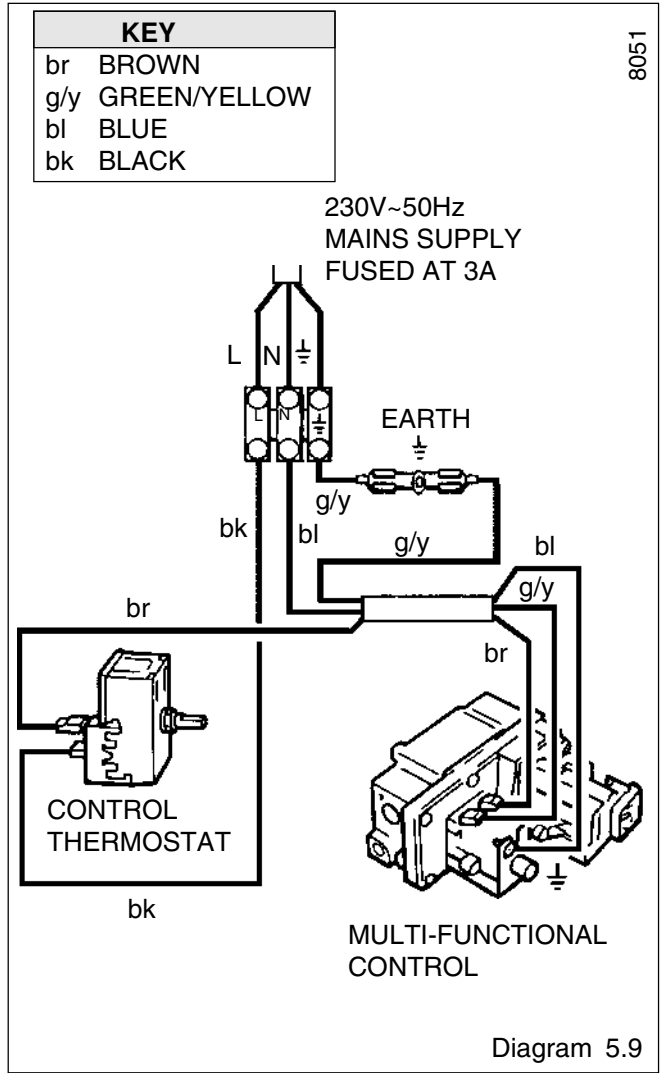
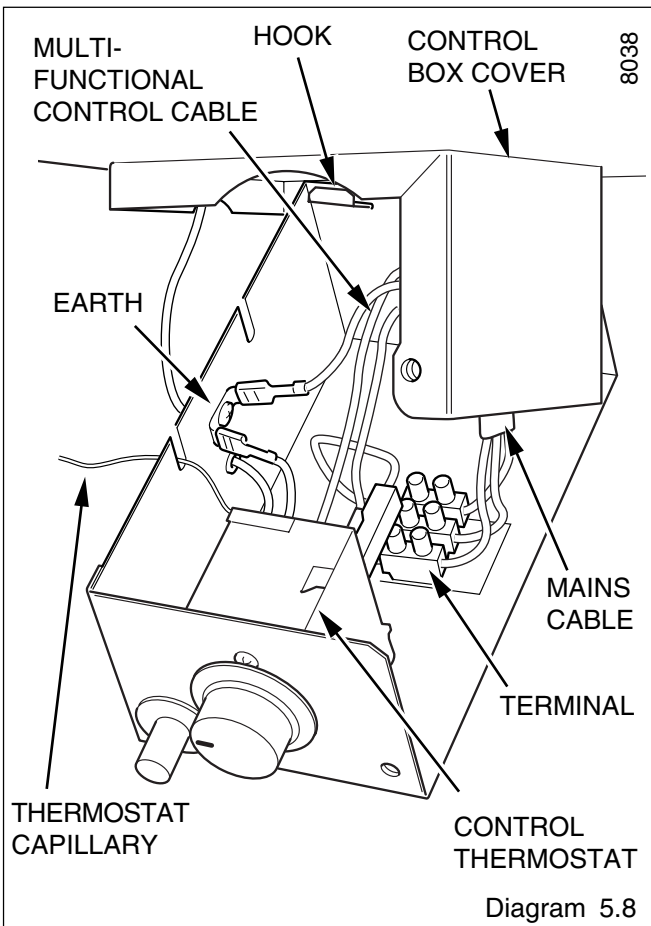
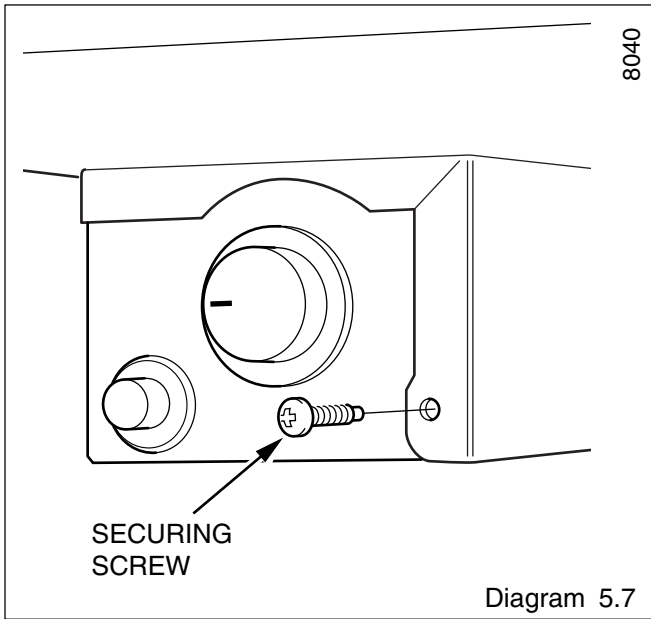

6 Commissioning

Please ensure the "Benchmark" logbook is completed and left with the user.

6.1

Make sure that the system has been thoroughly flushed out with cold water without the pump in place.

Refit the pump, fill the system with water, making sure that all the air is properly vented from the system and pump.

Before operating the boiler check that all external controls are calling for heat.

6.2 Initial Lighting and Testing

CAUTION. This work must be carried out by a competent person, in accordance with the current issue of BS6798.

Make sure that all naked lights and cigarettes are out.

Identify the controls by reference to diagram 6.1.

Turn the control thermostat knob "B" to "O" the Off position.

Remove gas pressure test point screw "E" and fit a suitable pressure gauge.

Turn the electrical supply on and check that all remote controls are calling for heat. Check that the pump is circulating water through the system.

Turn on the main gas supply and purge in accordance with the current issue of BS6891.

Turn boiler gas service cock "C" "On".

Push in control button "K", keep pressed in and at the same time operate the piezo unit button "G" until the pilot burner lights. After the pilot burner lights keep the button "K" pushed in for 20 seconds. If the pilot fails to stay alight a safety device in the multi-functional control prevents immediate relighting.

Do not attempt to relight until the safety device has reset, that is, after a minimum of three minutes.

Make sure that the pilot is alight and stable, view through window "H".

Check the length of the pilot flame, it should envelop the thermocouple tip as shown in diagram 6.2. The pilot rate can be adjusted, if necessary, by turning the pilot burner adjustment screw "N", having first removed the multi-functional control cover by releasing the screw, see diagram 6.1. Check the pilot supply connection for gas soundness, using a suitable leak detection fluid.

Fit the case by hooking it under at the top and securing with the wing nuts previously removed, see diagram 6.3.

Set the control thermostat knob "B" between "MIN" and "MAX" - "MAX" is about 82°C (180°F) and check that the burner lights smoothly. Check all the gas connections for soundness with a suitable leak detection fluid.

To set the burner pressure, operate the boiler for ten minutes, adjust the gas rate screw "F", see diagram 6.1 until the required pressure is obtained, see relevant Table 2 for setting pressures.

Should any doubt exist about the gas rate, check it using the gas meter test dial and a stop watch, at least ten minutes after the burner has lit, make sure that all other gas burning appliances and pilot lights are off.

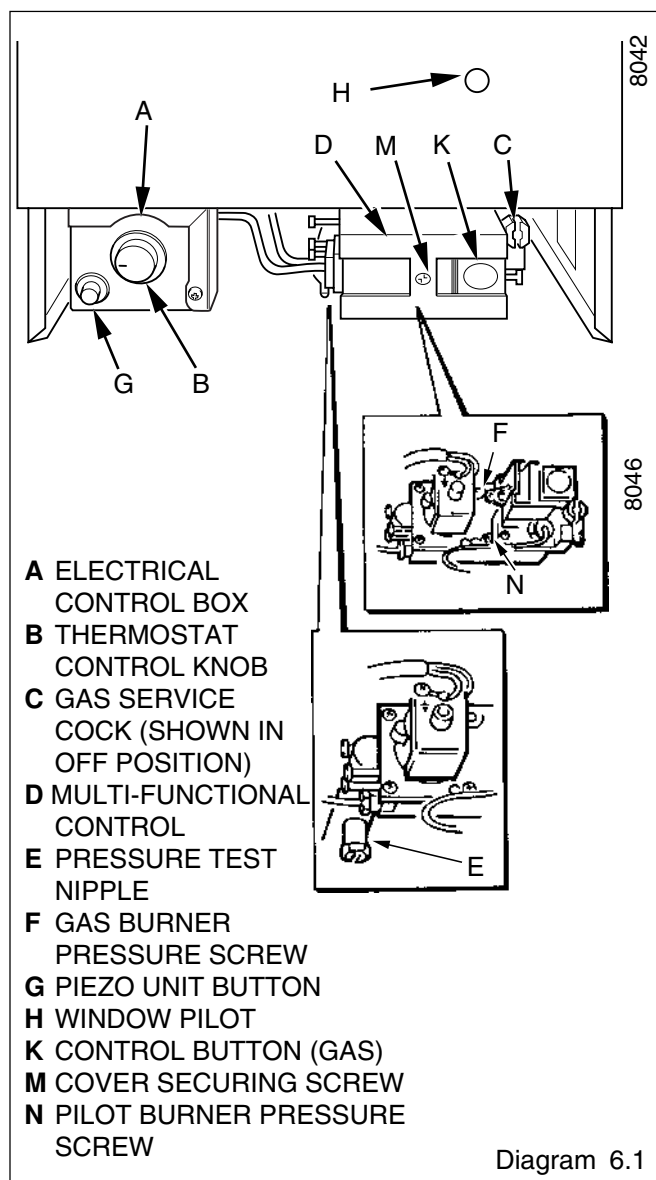

Gas Rates After 10 Minutes	
m ³ /h	1.70
ft ³ /h	60.0

These figures are offered as a guide only.

Stick the self adhesive arrow, from the loose items pack, in the appropriate place of the "MIN" "MED" and "MAX" column of the Data Label.

Remove the pressure gauge and refit the test point screw, making sure a gas tight seal is made.

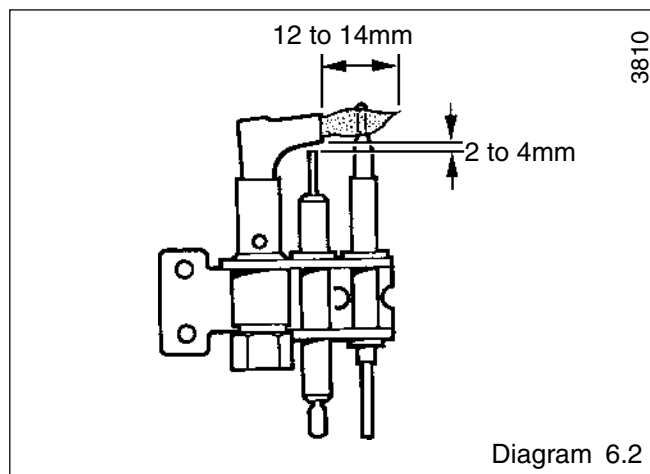

6 Commissioning

6.3 Testing

To check the operation of the flame failure device, turn the gas cock "Off".

The multi-functional control should shut down within 60 seconds, indicated by a "click" from the multi-functional control.

Turn gas cock "On" and relight the burner.

Allow the system to reach maximum working temperature and examine for water leaks.

There should be no undue noise in the system and no pumping over of water or entry of air at the open vent above the feed and expansion cistern.

The boiler should then be turned off and the system drained off as rapidly as possible, whilst still hot.

6.4 Adjustment - Fully Pumped Water System

When commissioning the system the boiler should first be fired with the bypass fully closed on full service, that is, central heating and domestic hot water. The system should then be balanced, adjusting the pump and lockshield valve as necessary. Having achieved a satisfactory condition operate the boiler with the bypass fully closed on minimum load, normally this will be central heating only with one radiator in the main living area operating. The bypass valve should be gradually opened to achieve the design temperature difference between the flow and return.

UNDER NO CIRCUMSTANCES SHOULD THIS VALVE BE LEFT IN THE FULLY CLOSED POSITION.

Note. Operate the boiler on full service and check the balancing, making further adjustments as necessary.

Do not attempt to adjust the control thermostat calibration.

6.5 Thermostatic Radiator Valves

If thermostatic radiator valves are fitted care must be taken to make sure that an adequate flow rate through the boiler when they close, refer to the current issue of BS7478 for guidance.

6.6 Completion

Fit the controls cover by hooking into the sliders and pushing it back as far as it will go, see diagram 6.3.

6.7 Protection Against Freezing

If the boiler is to be out of use for a period of time during severe weather conditions we recommend that the whole of the system including the boiler, be drained off to avoid the risk of freezing up.

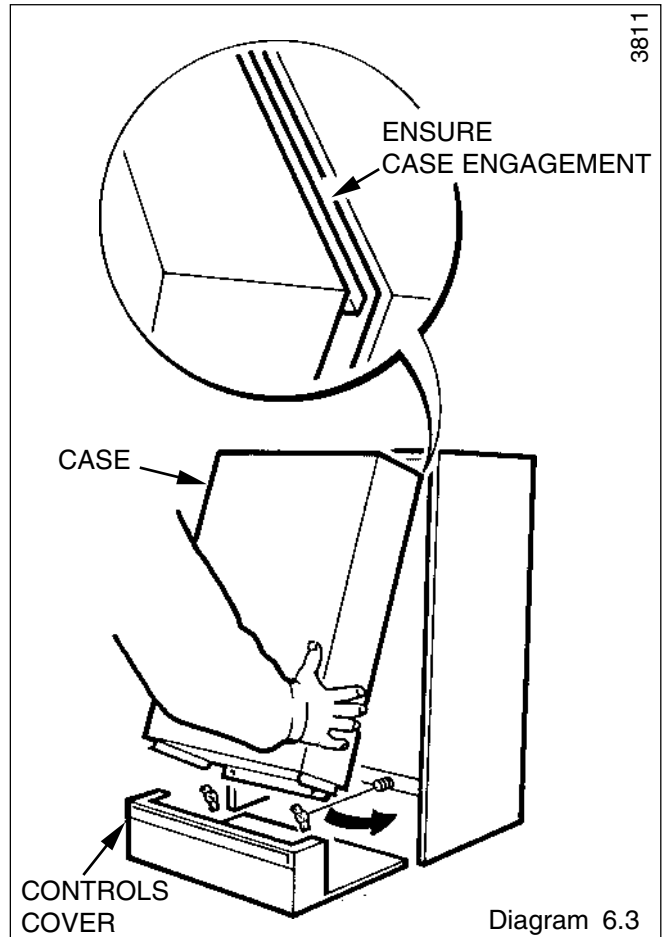

Instructions to the User

7 Instructions to the User

Instruct and demonstrate the safe and efficient operation of the boiler, heating system and domestic hot water system.

Advise the user, that to ensure the continued efficient and safe operation of the boiler it is recommended that it is checked and serviced at regular intervals. The frequency of servicing will depend upon the particular installation and usage, but in general once a year, preferably at the end of the heating season should be enough.

Draw attention, if applicable, to the current issue of the Gas Safety (Installation and Use) Regulations, Section 35, which imposes a duty of care on all persons who let out any property containing a gas appliance.

It is the Law that servicing is carried out by a competent person.

Advise the user of the precautions necessary to prevent damage to the system and building in the event of the heating system being out of use during frost and freezing conditions.

Reminder, leave these instructions and the 'Benchmark' logbook with the user.

8 Servicing

Notes: To ensure the continued efficient and safe operation of the boiler it is recommended that it is checked and serviced as necessary at regular intervals. The frequency of servicing will depend upon the particular installation conditions and usage, but in general once a year, preferably at the end of the heating season should be enough.

It is the Law that any servicing is carried out by a competent person.

Before servicing turn off the gas and isolate the electrical supply to the boiler.

After completing a service always test for gas soundness and carry out functional check on controls.

Unless stated otherwise all parts are replaced in the reverse order to removal.

8.1 Access

Refer to diagram 6.3 and slide the controls cover forwards and off.

Undo the wing nuts and remove the case.

When refitting the case check the condition of the case seal, if it needs replacing refer to Section 10.12.

8.2 Main Burner

Remove the flueway access door by removing the screws, see diagram 8.1.

Remove the combustion chamber front, see diagram 8.1.

Disconnect the pilot pipe union connector and ignition lead, see diagram 8.2.

Separate the pilot assembly from the main burner, by removing the pilot shield securing nut, shakeproof washer and move to the right. Remove the burner securing nut and wing nut from the burner support bracket, see diagram 8.3.

To remove the main burner from the main injector at the rear, raise the burner up and forwards, easing the pilot pipe to the side, to clear, take care not to damage the combustion chamber insulation or the pilot burner assembly.

Use a vacuum cleaner or suitable stiff brush to clean the burner thoroughly, making sure that all the burner ports are clear and unobstructed.

Do not use a brush with metallic bristles.

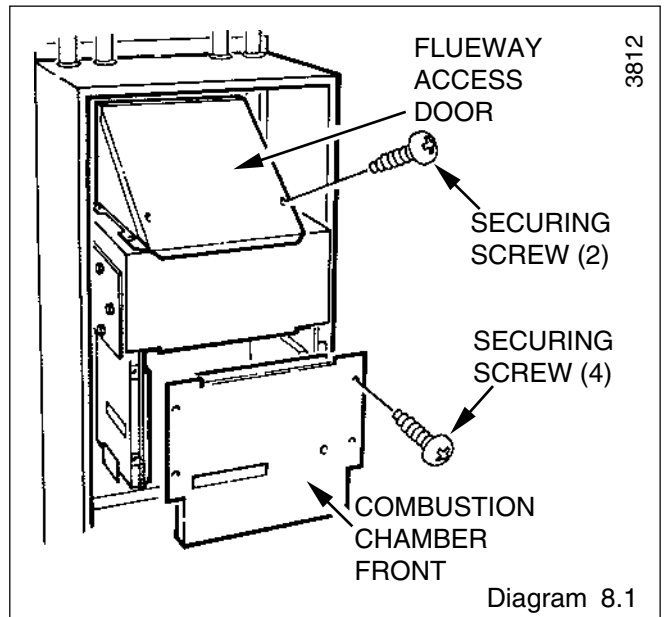

Diagram 8.1

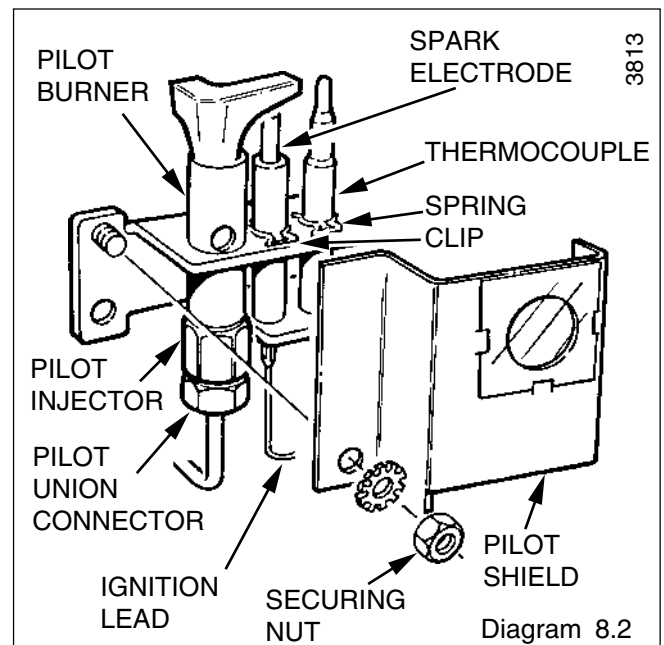

Diagram 8.2

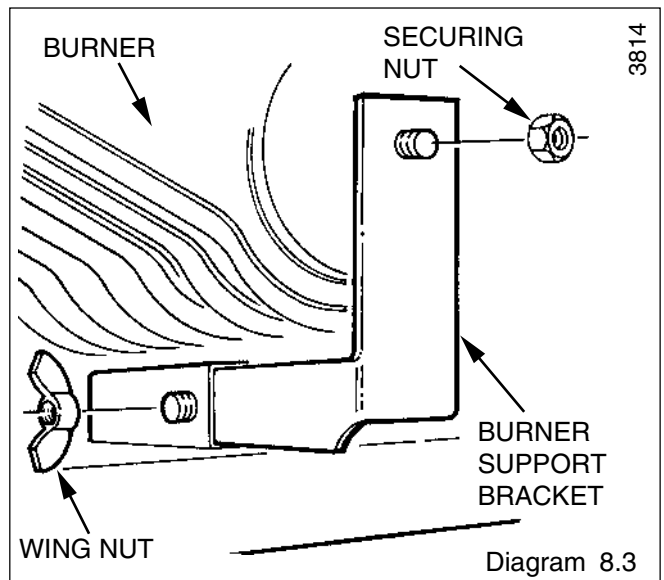

Diagram 8.3

8 Servicing

8.3 Cleaning Heat Exchanger

Place a sheet of paper in the base of the combustion chamber.

Remove the baffles from the heat exchanger, note, when replacing, the 50BF is marked "TOP FRONT", see diagram 5.6.

Clean the heat exchanger, paying particular regard to the gaps between the fins, with a suitable stiff brush.

Do not use a brush with metallic bristles.

Remove the paper together with any debris.

8.4 Main Injector

The main injector can be inspected and cleaned as necessary.

If removing for cleaning do not use a wire or sharp instrument on the hole.

Use a little suitable sealant on the external thread when refitting to make sure a gas tight seal is made.

8.5 Electrode, Pilot Burner and Pilot Injector

Release the thermocouple by removing the spring clip, pull the thermocouple down from the pilot assembly, see diagram 8.2.

Inspect and clean pilot burner assembly.

Remove the pilot injector by unscrewing from the pilot burner assembly, clean by blowing through it.

Note. On refitting and after cleaning the heat exchanger and main burner make sure the main burner is fitted correctly, that is, located on the main injector and horizontal, see diagram 8.4.

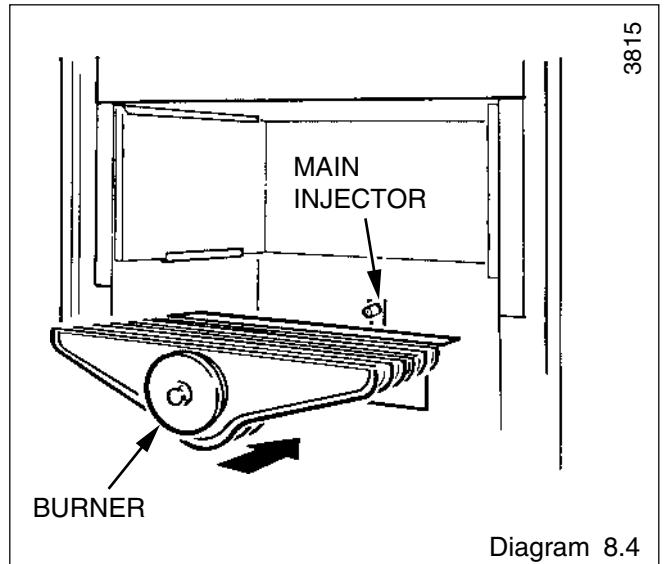

9 Fault Finding

0032M

**PILOT WILL NOT LIGHT
START HERE**

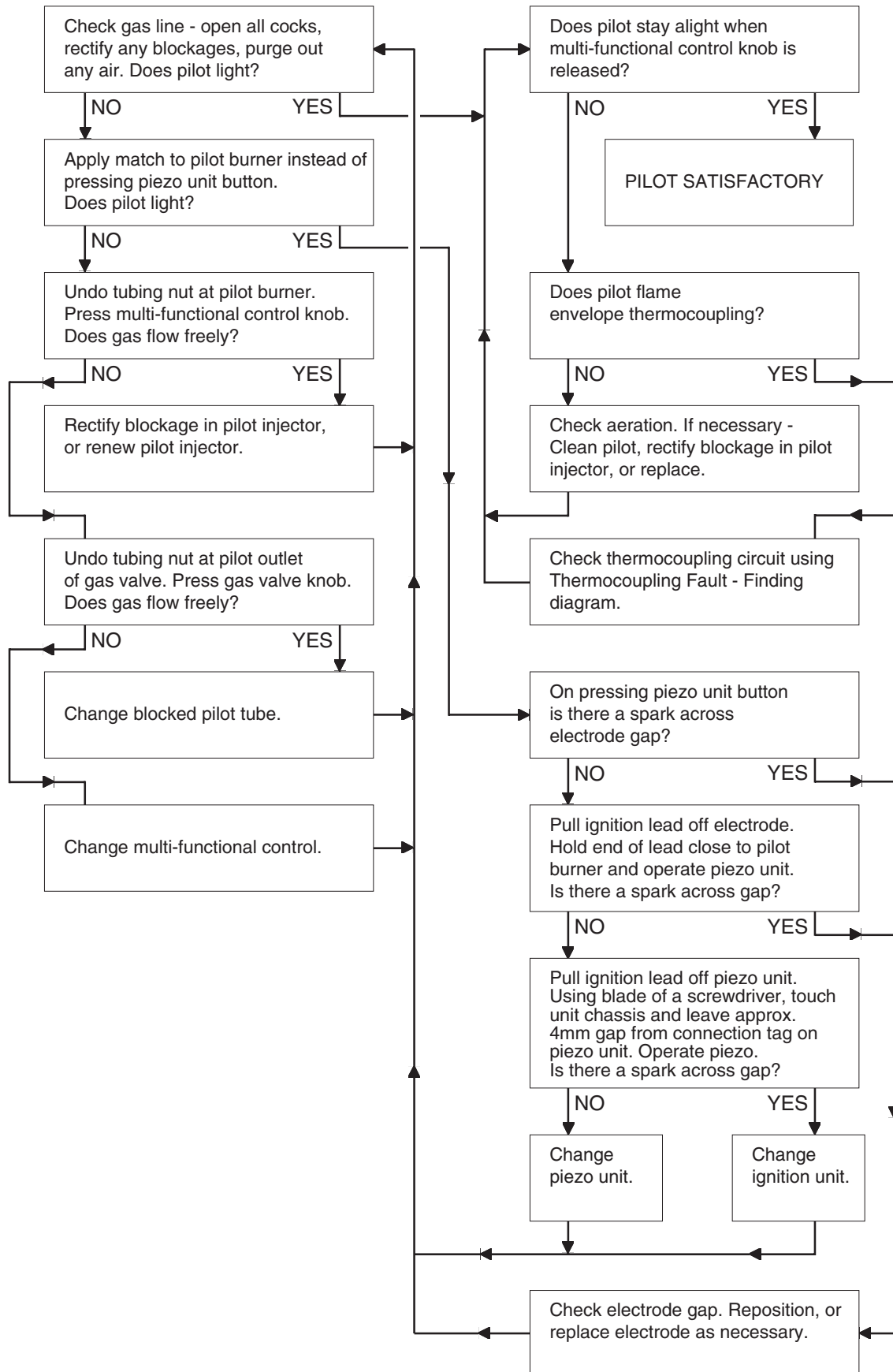

Diagram 9.1

9 Fault Finding

THERMOCOUPLE FAULT FINDING

4634

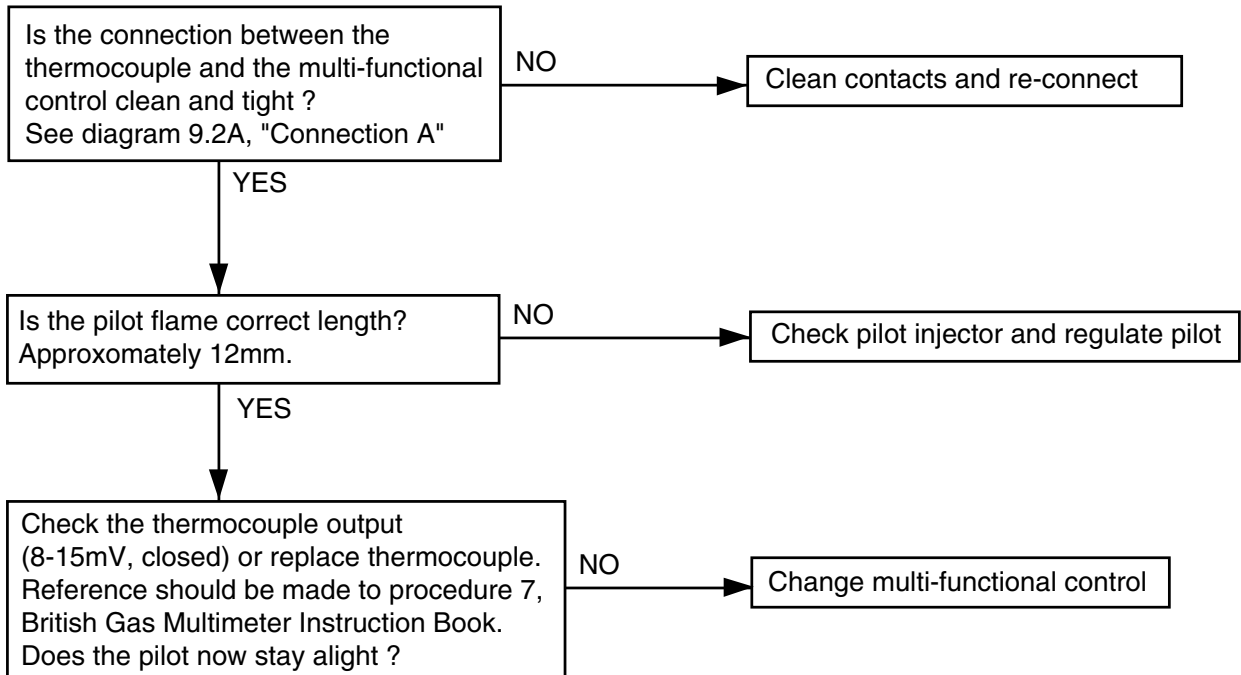

Diagram 9.2

9.1 Pilot

Refer to Chart 9.1.

9.2 Thermocouple

To test the thermocouple a meter with a range of 6 to 30mV is required together with a thermocouple interrupter test unit.

Refer to thermocouple fault finding chart, diagram 9.2 and diagram 9.2A.

9.3 Electrical

Important. On completion of the service/fault finding task which has required the breaking and remaking of the electrical connections the earth continuity, polarity, short circuit and resistance to earth checks must be repeated, using a suitable multimeter.

Refer to Fault Finding, Wiring and Functional Flow diagram 9.3 and 9.4.

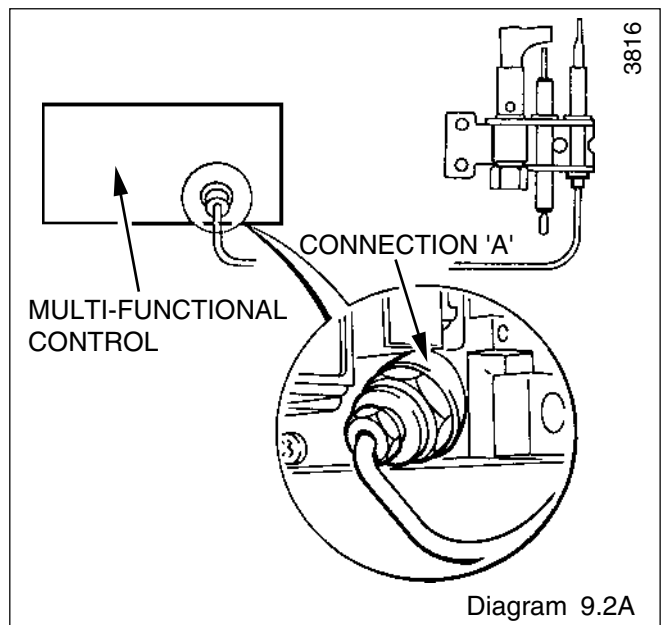

Diagram 9.2A

9 Fault Finding

ELECTRICAL FAULT FINDING

9007

Ensure that all services are available at the appliance. ie. Gas, Electricity, Water.
Also turn control thermostat fully on and check to see if pilot is lit.

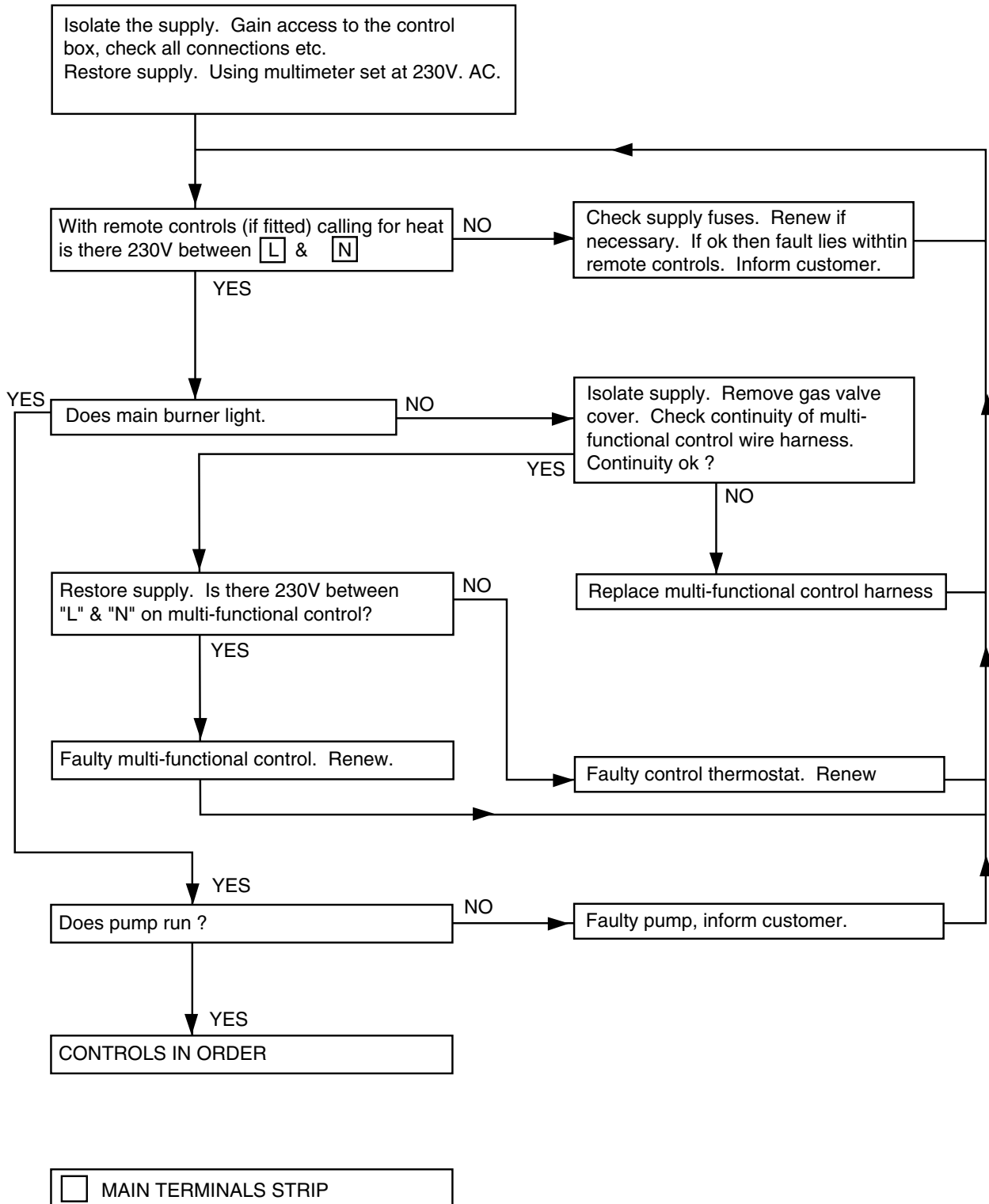

Diagram 9.3

9 Fault Finding

FUNCTIONAL FLOW

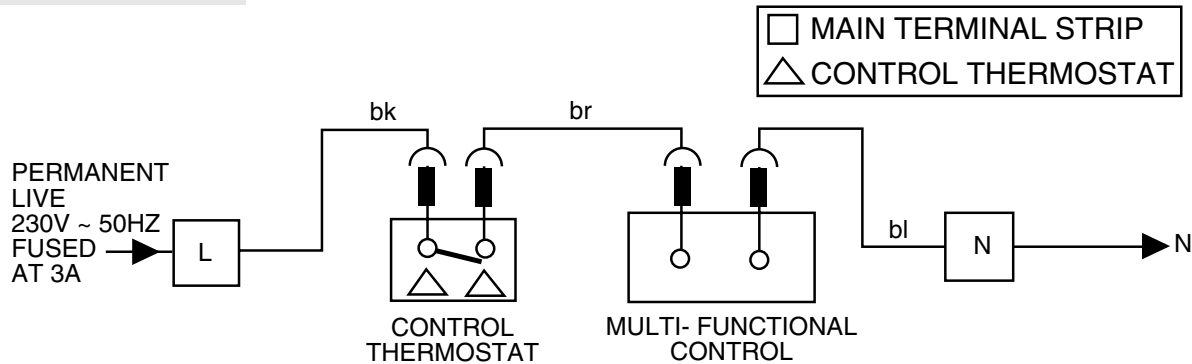

Diagram 9.4

8050

10 Replacement of Parts

Replacement of parts must only be carried out by a competent person.

Gain access as Section 8.1

Before replacing any parts isolate the boiler from the electrical supply and turn the gas supply off at the gas service cock, indicator slot to be vertical.

Unless stated otherwise, all parts are replaced in the reverse order to removal.

After replacing any parts always test for gas soundness and if necessary carryout functional check of controls.

10.1 Control Thermostat - diagram 10.1

Open and support the electrical control box, refer to Section 5.4.

Remove the control knob. Remove the electrical connections from the control thermostat body.

Release the control thermostat body by unscrewing the two screws and shakeproof washers in the front of the control box.

Remove the split pin and withdraw the control thermostat phial from its pocket. Remove the control thermostat complete from the boiler.

Re-assembly note. When fitting the control thermostat, make sure that the control thermostat phial is covered with heat sink compound and then fully inserted into the phial pocket and that the capillary is within the gland seal. Remake the electrical connections. There must be no kinks or sharp bends in the capillary.

Make sure that the capillary is positioned so that it passes through the cut out in the control box.

10.2 Pilot Burner and Pilot Injector

Proceed as relevant parts of Section 8.2 and 8.5.

10.3 Electrode - diagram 8.2

Proceed as relevant parts of Section 8.2, release the electrode by removing the spring clip.

10.4 Piezo Unit - diagram 10.2

Open and support the electrical control box, refer to Section 5.4.

Disconnect the ignition lead at the piezo unit.

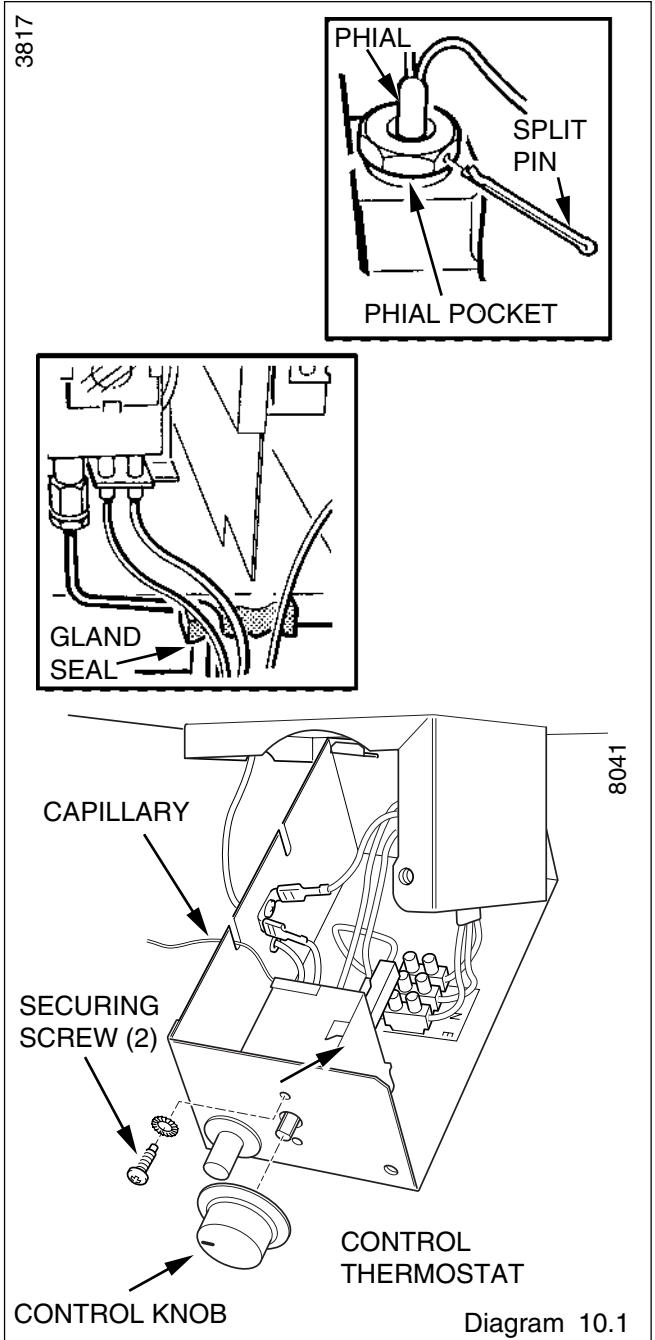

Diagram 10.1

10 Replacement of Parts

Note: To ease the removal of the piezo unit it is advisable to temporarily remove the boiler thermostat from the control box, refer to Section 10.1.

Depress the retaining tabs and remove the Piezo unit.

10.5 Thermocouple - diagram 10.3

Proceed as relevant parts of Sections 8.2 and 8.5.

Unscrew thermocouple nut.

When refitting do not tighten the thermocouple nut more than a quarter turn beyond finger tight.

10.6 Multi-functional Control - diagram 10.3

Remove the screw to release the multi-functional control cover.

Disconnect the electrical leads, thermocouple and pilot supply pipe at the valve.

Undo the four screws each side of the multi-functional control to release the gas service cock and the burner supply pipe, take care not to damage the "O" ring seals.

Remake the connections.

Do not tighten the thermocouple nut more than a quarter turn beyond finger tight.

It will be necessary to purge the pipework and the multi-functional control before relighting, refer to "Commissioning".

Refit multi-functional control cover.

10.7 Solenoid - diagram 10.4

With the multi-functional control cover removed disconnect the electrical leads, remove the retaining clip and solenoid.

10.8 Main Burner

Remove the main burner as Section 8.2.

10.9 Main Injector

Remove the main injector as Section 8.4.

10.10 Insulation - diagram 10.5

Combustion Chamber Front

Remove the combustion chamber front as Section 8.2. Remove the retaining screw and slide the insulation out. .

Sides

Slide the insulation pads out.

Rear

With the side pads removed the rear pad can now be removed.

10.11 Viewing Window - diagram 10.6

Remove the old adhesive aluminium foil gasket and the old mica window. Replace with a new mica window. Peel off the backing paper and secure with new self adhesive aluminium foil gasket, see diagram 10.6. Ensure no air bubbles are trapped underneath the foil.

Important

Make sure that the mica window fully covers the opening and that the hole in the aluminium foil gasket is centred over opening.

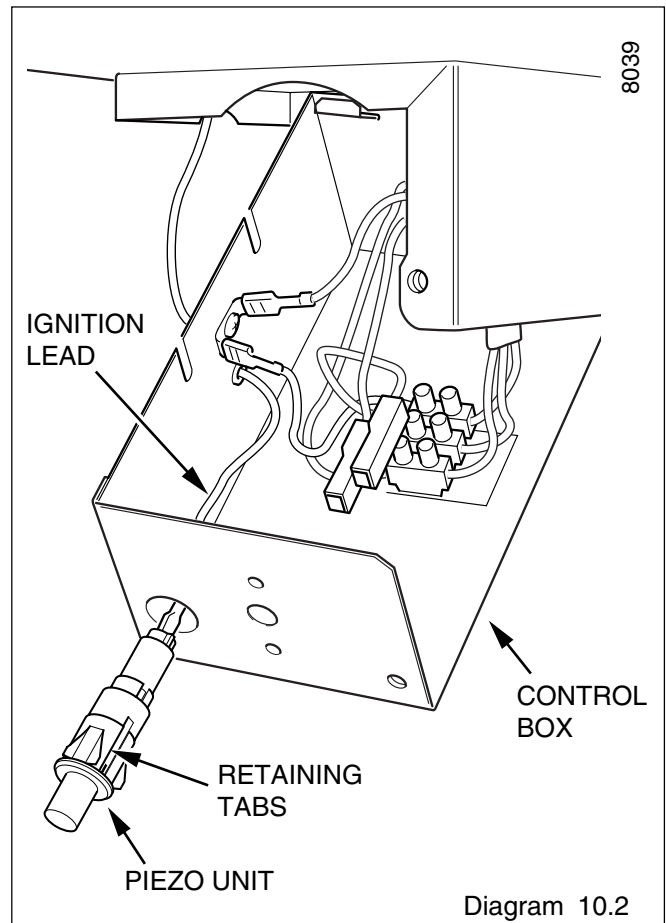

Diagram 10.2

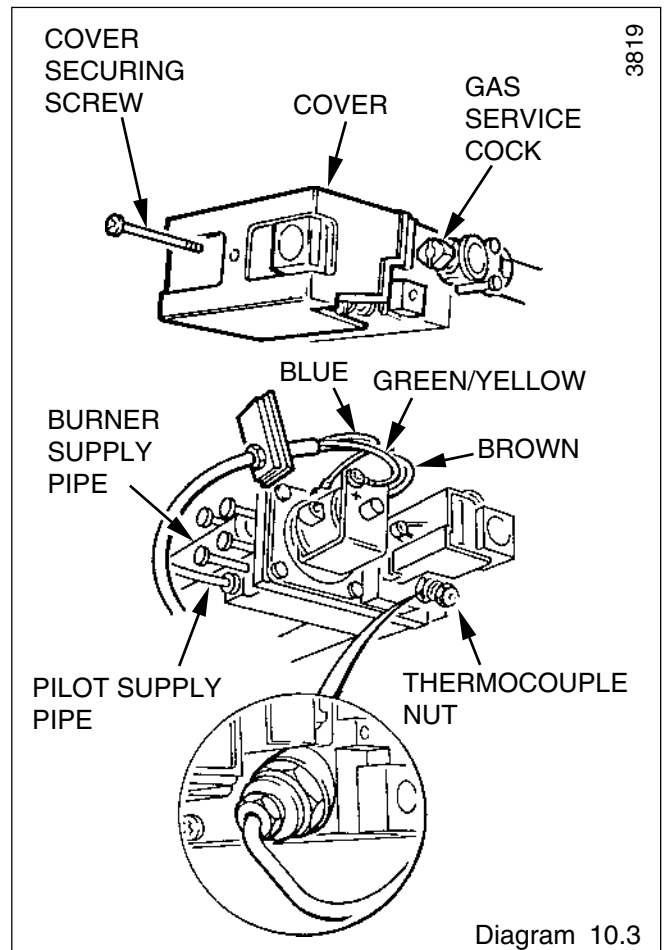
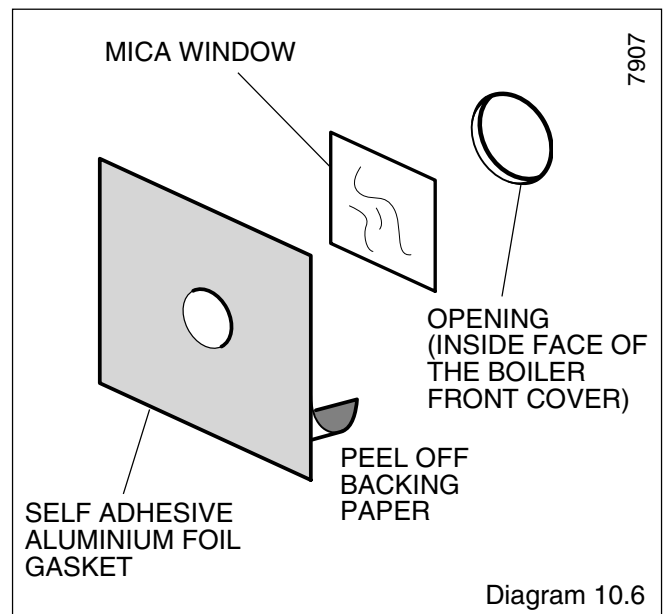
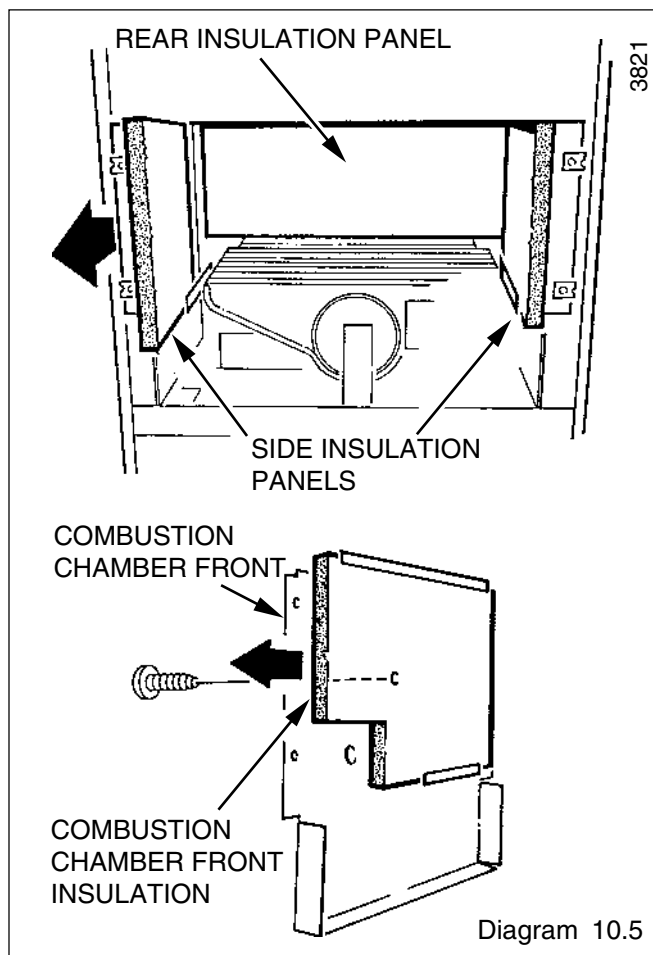
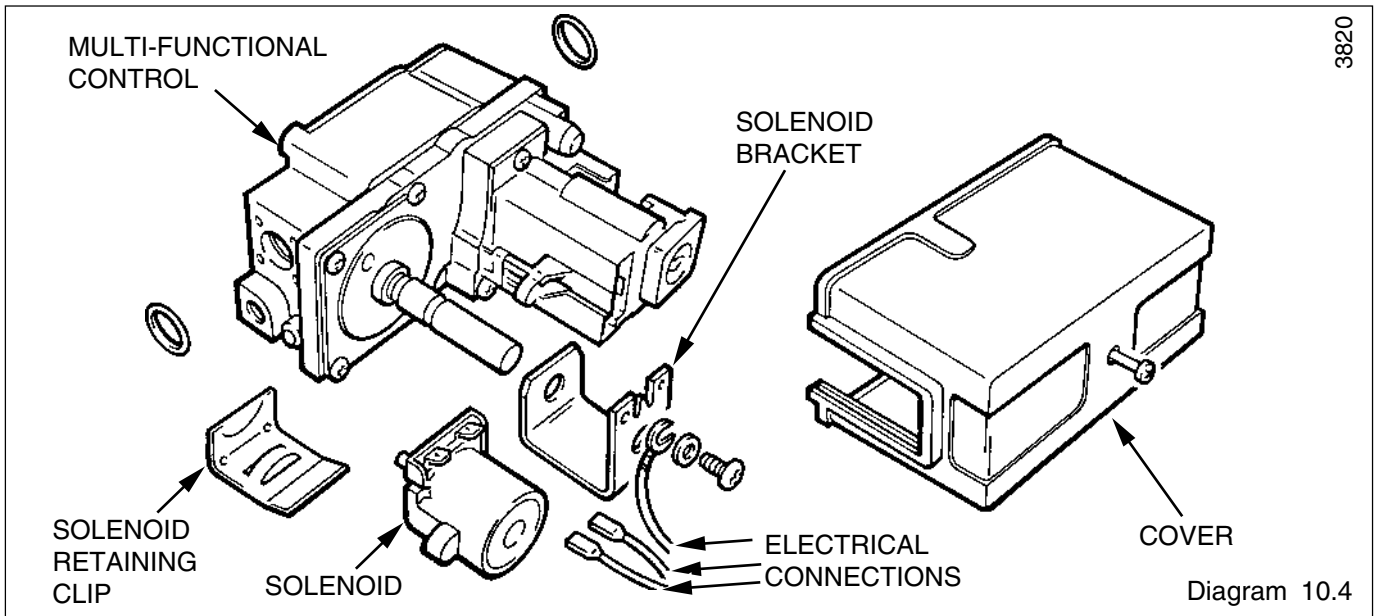

Diagram 10.3

10 Replacement of Parts



10.12 Case Seal

To remove the seal, carefully bend up the tabs.

Remove the seal, making sure that all the old adhesive is removed.

When fitting the new seal, make sure that it fits into the corners and has not buckled.

Carefully bend the tabs down.

11 Spare Parts

11.1 Part Identification

The key number on the diagram and the list will help to identify the part.

11.2 Ordering

When ordering any spare parts please quote the number and description from the list together with the model name and serial number.

If ordering from British Gas also quote the GC number of the appliance and part.

8048

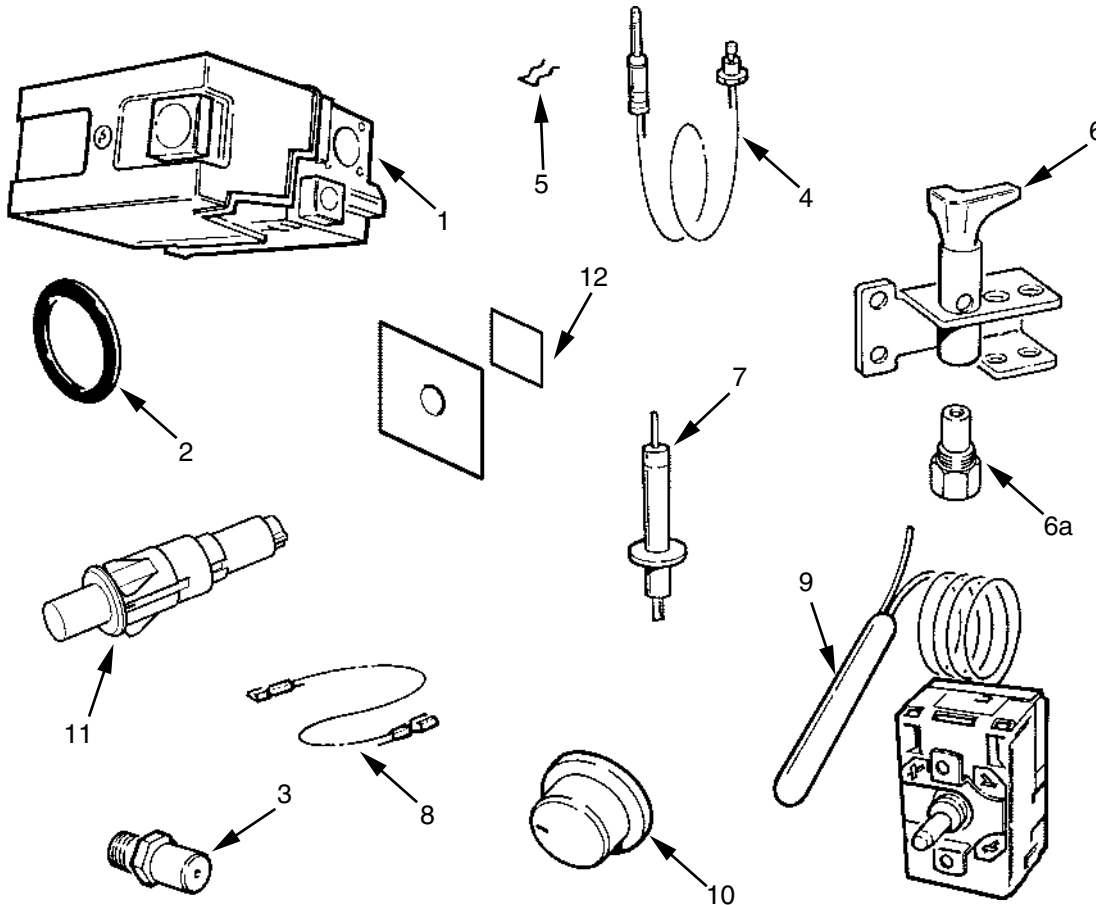

Diagram 11.1

Key No	Part No	Description	GC Part No
1	429549	Multi-functional control	312 926
2	208040	Joint ring	334 592
3	203096	Injector - 50BF	313 305
4	202432	Thermocouple	E00 999
5	K3580	Clip - thermocouple	390 983
6	203429	Pilot burner	379 021
7	202621	Spark electrode	379 020
8	WW4609	Ignition lead	136 464
9	800399	Thermostat - control	313 915
10	204687	Control knob	*****
11	202713	Piezo igniter	*****
12	801236	Mica window and gasket	

Because of our constant endeavour for improvement, details may vary slightly from those shown in these instructions.