Wall hung, fan flue, room sealed, high efficiency gas boiler

Service manual

RIVA COMPACT HE

Models:	G.C. Appl. No.
M96.24SM/C2	47-583-05
M96.28SM/C2	47-583-06
M96.32SM/C2	47-583-07
M96.24SR/C2	
M96.28SR/C2	41-583-02

Leave this manual adjacent to the gas meter

Table of contents

1	Overall information	1	11	Modulating gas valve	25
1.1	Overall View	1	11.1	Function	25
1.2	Hydraulic diagram	1	11.2	Nomenclature of the parts	25
2	General access and emptying hydraulic circuits	2	11.3	Adjustment	25
2.1	Nomenclature	2	11.4	Checks	26
2.2	Body panels	2	11.5	Removal of the gas valve	26
2.3	Control panel	2	12	Primary circuit flow switch	27
2.4	Access to the sealed chamber	3	12.1	Function	27
2.5	Emptying the primary circuit	3	12.2	Checks	27
2.6	Emptying the d.h.w. circuit	3	12.3	Removal	27
3	Diagrams	4	13	Expansion vessel and temperature–pressure gauge	28
3.1	Wiring diagram M96.24SM/... M96.28SM/... M96.32SM/...	4	13.1	Function	28
3.2	Wiring diagram M96.24SR/...M96.28SR/...	5	13.2	Checks	28
3.3	Functional flow diagrams	6	13.3	Removal of the expansion vessel	28
3.4	Circuit voltages	7	13.4	Removal of the temperature–pressure gauge	28
4	Fault finding	8	14	D.h.w. flow switch, filter	29
5	Primary heat exchanger	10	14.1	Function	29
5.1	Function	10	14.2	Description and location of parts	29
5.2	Removal	10	14.3	Checks	29
5.3	Cleaning	10	14.4	Removal of the sensor	29
6	Condensing heat exchanger	11	14.5	Removal of the flow switch group and d.h.w. circuit filter	29
6.1	Function	11	14.6	Flow limiter	29
6.2	Removal	11	15	Temperature probe	31
7	D.h.w. heat exchanger	12	15.1	Function	31
7.1	Function	12	15.2	Checks	31
7.2	Removal	12	15.3	Removal	31
8	Pump	13	16	By–pass valve	32
8.1	Function	13	16.1	Function	32
8.2	Checks	13	16.2	Removal	32
8.3	Removal	13	17	Fan, venturi device and Air pressure switch	33
9	Three way diverter valve	14	17.1	Function	33
9.1	Function	14	17.2	Checks	33
9.2	Checks	14	17.3	Removal of the Fan	34
9.3	Removal of the electric actuator	14	17.4	Inspection and removal of the venturi device	34
9.4	Removal of the diverter group and its internal parts	15	17.5	Removal of the Air pressure switch	35
10	Electronic control/ignition p.c.b.	16	18	Ignition and detection electrodes	36
10.1	Function	16	18.1	Function	36
10.2	Selection and adjustment devices	16	18.2	Checks	36
10.3	Checking the temperature	17	18.3	Removal	36
10.4	Operation lights	18	19	Safety thermostat	37
10.5	Setting the boiler control function modes	18	19.1	Function	37
10.6	Reignition frequency setting	19	19.2	Checks	37
10.7	Combi / C.H. only mode setting	19	19.3	Removal	37
10.8	Ignition gas pressure adjustment	20	20	Flue temperature probe NTC	38
10.9	Checks	21	20.1	Function	38
10.10	Removal of the electronic control p.c.b.	21	20.2	Checks	38
10.11	Thermal control in the "❄️" mode	23	20.3	Removal	38
10.12	Thermal control in the "☀️" mode	23	21	Condensate trap	39
10.13	Ignition and control sequence	24	21.1	Function	39
			21.2	Removal	39
			22	Short spare parts list	40

1 Overall information

1.1 Overall View

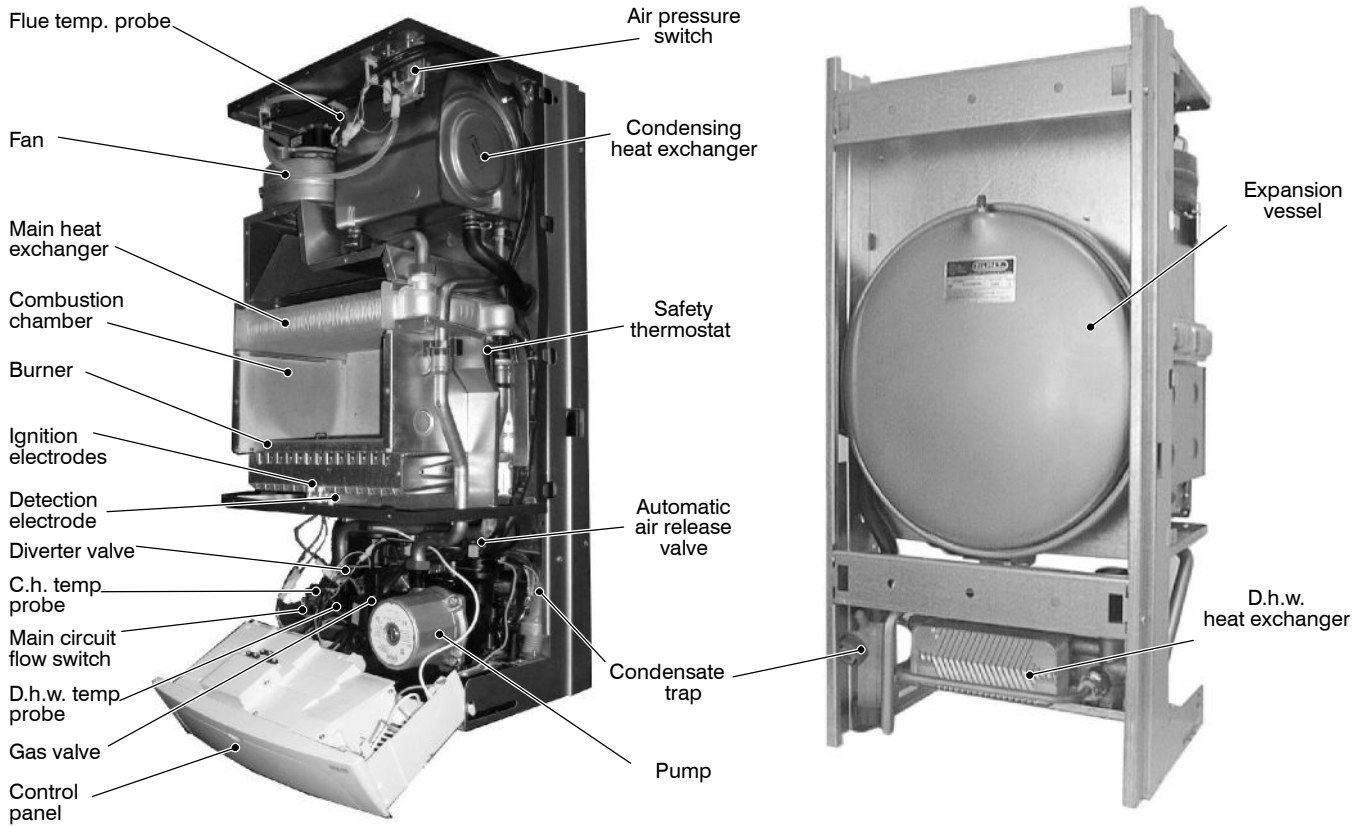

1.2 Hydraulic diagram

Central heating (c.h.) operation

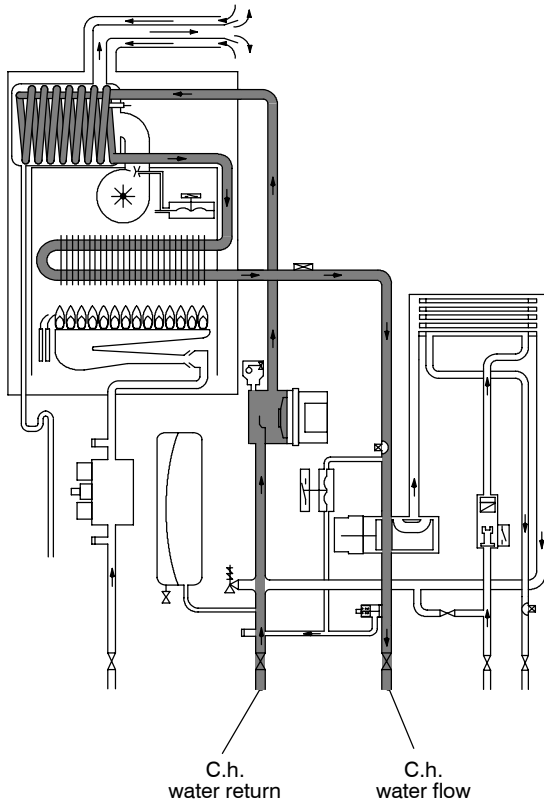

Domestic hot water (d.h.w.) operation

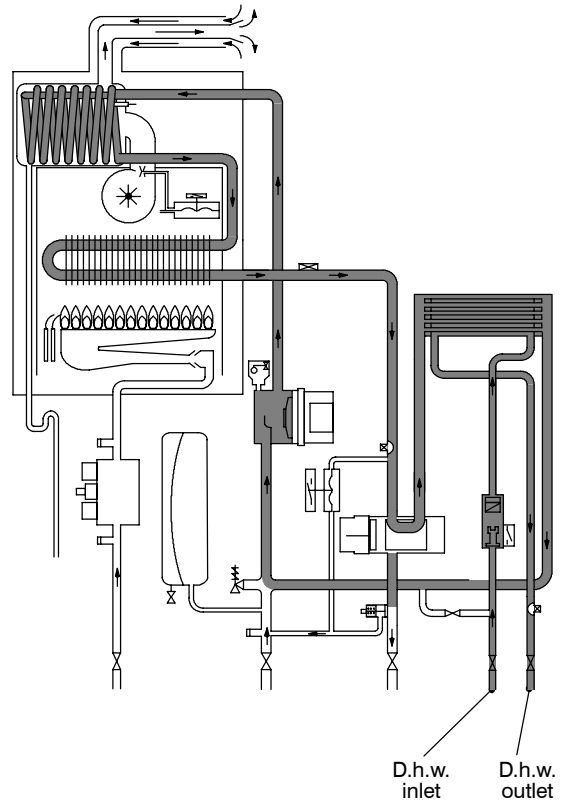

2 General access and emptying hydraulic circuits

2.1 Nomenclature

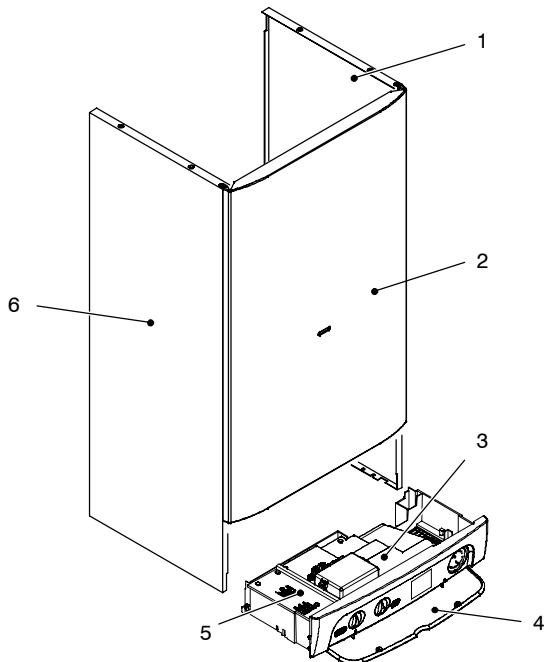

Fig. 1

- 1 Right side panel
- 2 Front panel
- 3 Control panel lid
- 4 Control panel cover
- 5 Service panel
- 6 Left side panel

2.2 Body panels

Warning: isolate the boiler from the mains electricity supply before removing any covering or component.

For the most part of the check and maintenance operations it is necessary to remove one or more panels of the case.

The side panels can be removed only after the removal of the front panel.

To remove the front panel remove screws A (Fig. 2), lift the panel and remove it.

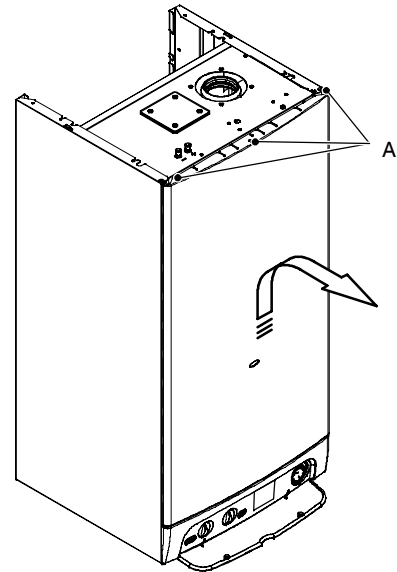

Fig. 2

To remove the side panels loosen the screws B and C (Fig. 3), bring the base of the panels away from the boiler and lift them, freeing them from the top hooks.

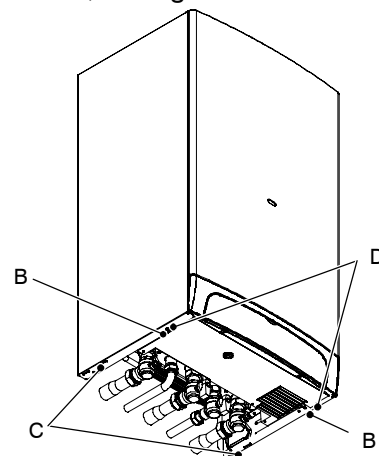

Fig. 3 – bottom view of the boiler

2.3 Control panel

Warning: isolate the boiler from the mains electricity supply before removing any covering or component.

To gain access to the parts located inside the control panel proceed as follows:

- 1 Remove the front panel of the case
- 2 Loosen the screws B and C (Fig. 3).
- 3 Remove the screws D
- 4 Move the lower part of the side panels as indicated in Fig. 4 and pull the control panel. When completely pulled out, the panel can rotate 45° downwards to facilitate the service operations on the internal parts.

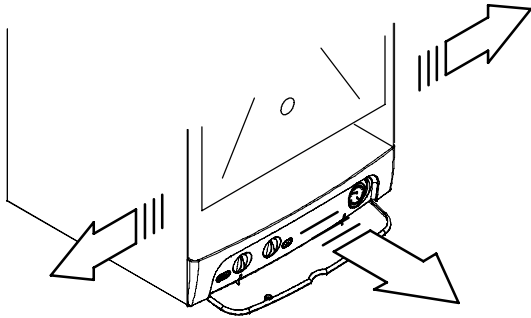

Fig. 4

- 5 Remove the screws *E* and remove the service panel (Fig. 5);
- 6 To gain access to the electronic regulation PCB remove the screws *F* and remove the control panel lid (Fig. 5);

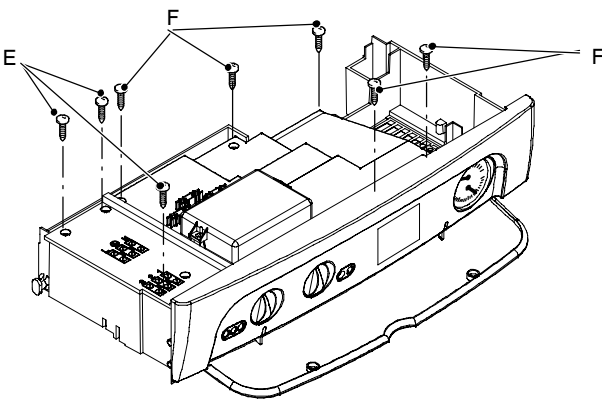

Fig. 5

2.4 Access to the sealed chamber

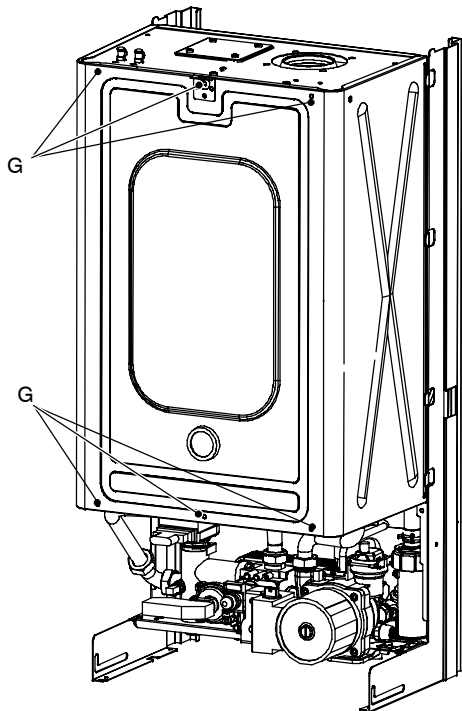

Fig. 6

To gain access to the parts contained in the sealed chamber it is necessary to remove the lid of the sealed chamber.

For this purpose, remove the front and side panels of the case, remove the screws *G* as indicated in Fig. 6 and remove the lid.

2.5 Emptying the primary circuit

- 1 Close the c.h. circuit flow and return cocks *H*. (Fig. 7).

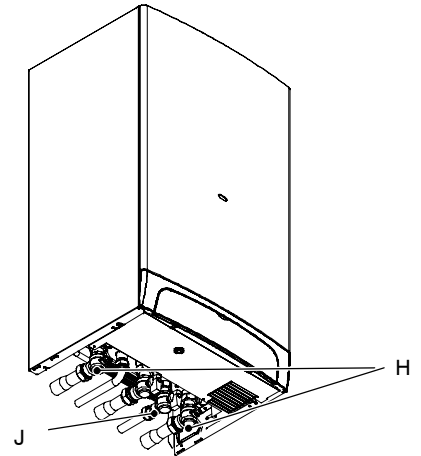

Fig. 7 – bottom view of the boiler

- 2 Remove the front and right panels of the boiler.
- 3 Open the drain tap *I* (Fig. 8) until the boiler is completely emptied.
- 4 Close drain tap again once the emptying has been completed.

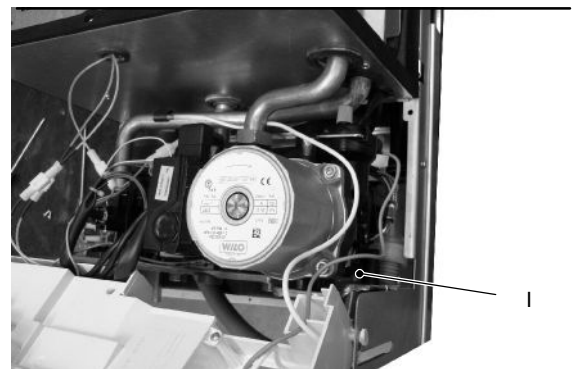

Fig. 8

2.6 Emptying the d.h.w. circuit

- 5 Close the d.c.w. inlet cock *J* (Fig. 7);
- 6 Open one or more hot water taps until the boiler has been completely emptied.

3 Diagrams

3.1 Wiring diagram M96.24SM/... M96.28SM/... M96.32SM/...

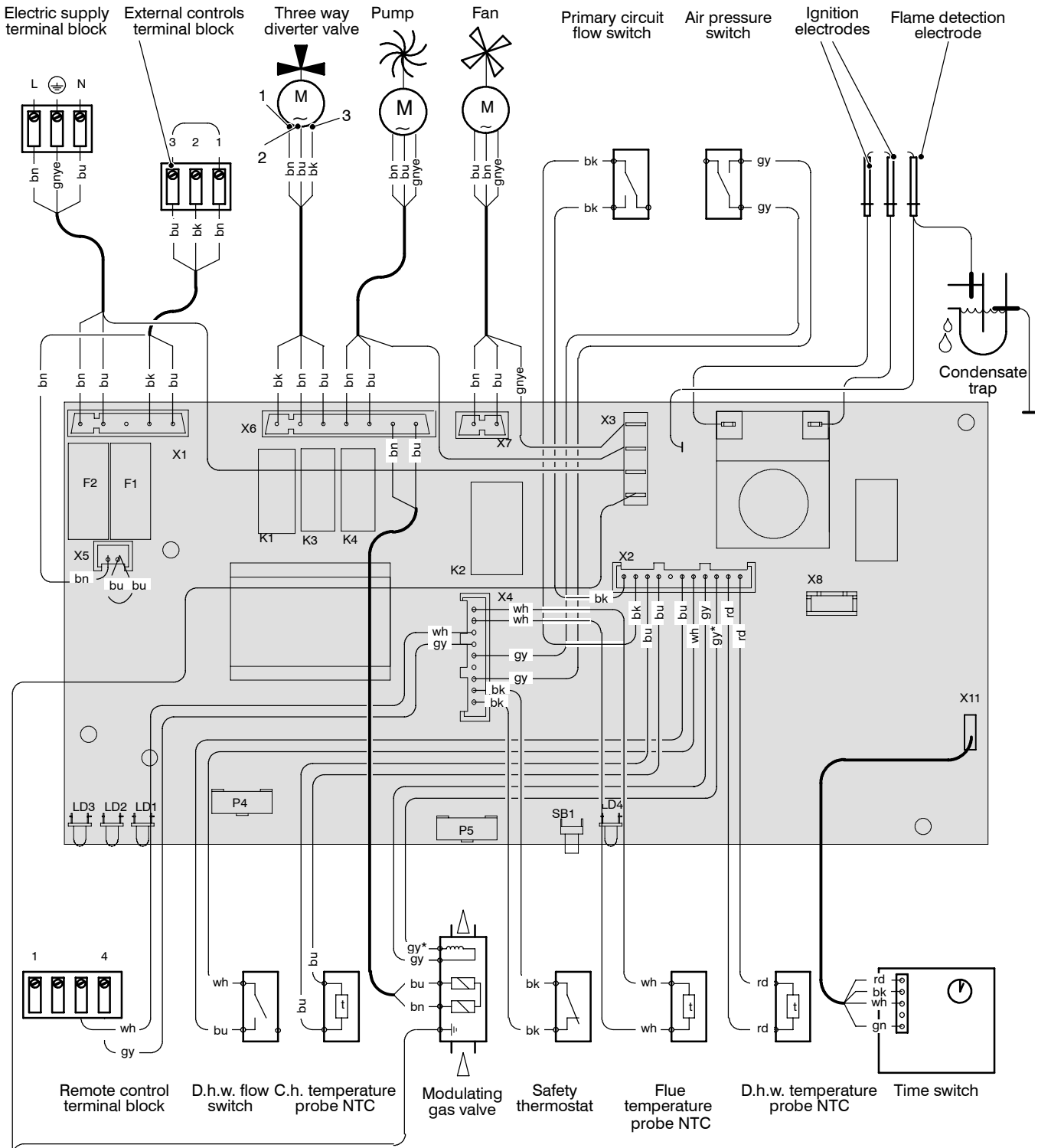

- bn = brown
- bu = blue
- bk = black
- wh = white
- rd = red
- gy = grey
- gn = green
- ye = yellow
- vt = violet
- og = orange
- gnye = green/yellow

* alternative, yellow

3.2 Wiring diagram
M96.24SR/...M96.28SR/...

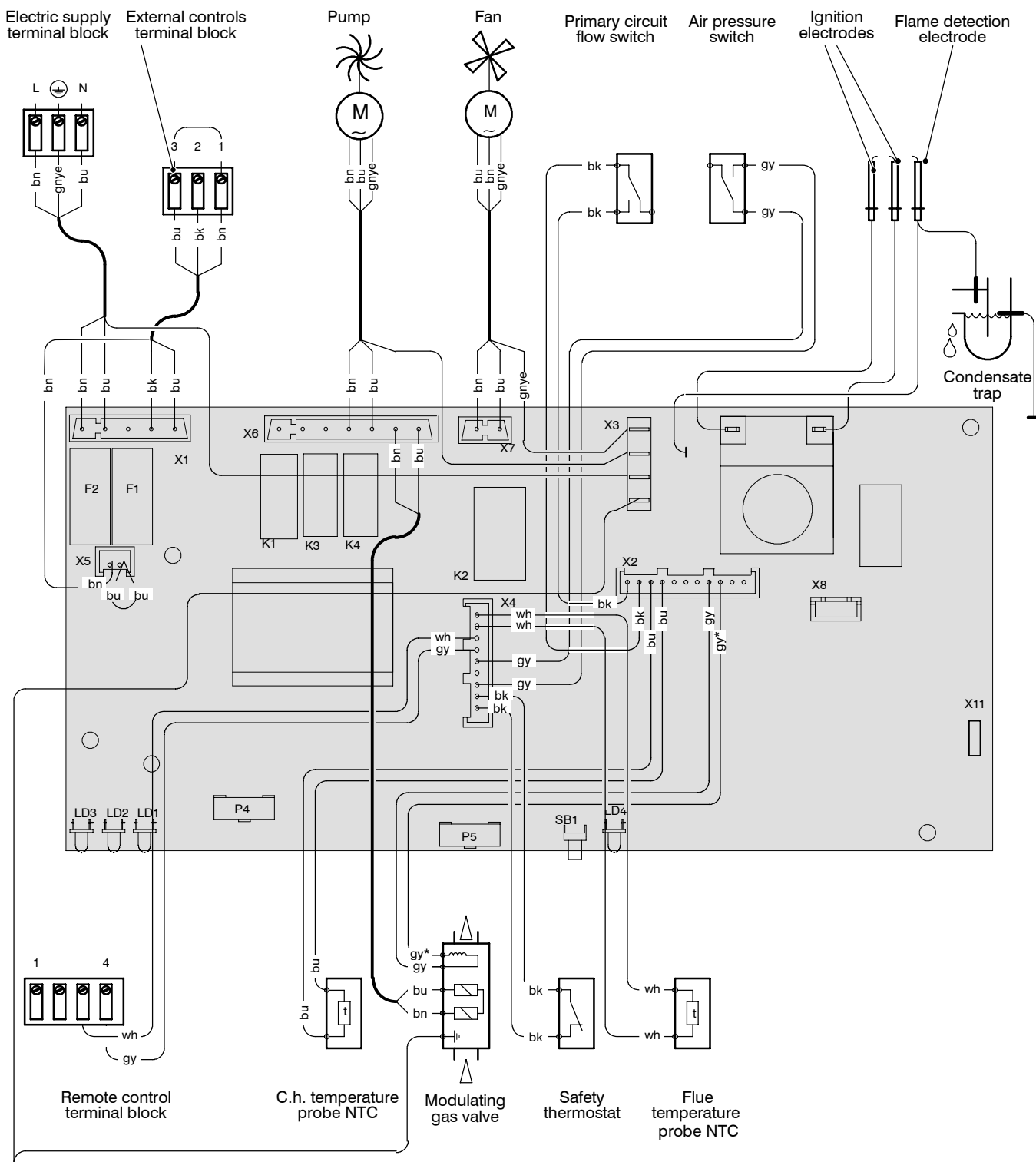

- bn = brown
- bu = blue
- bk = black
- wh = white
- rd = red
- gy = grey
- gn = green
- ye = yellow
- vt = violet
- og = orange
- gnye = green/yellow

* alternative, yellow

3.3 Functional flow diagrams

General layout

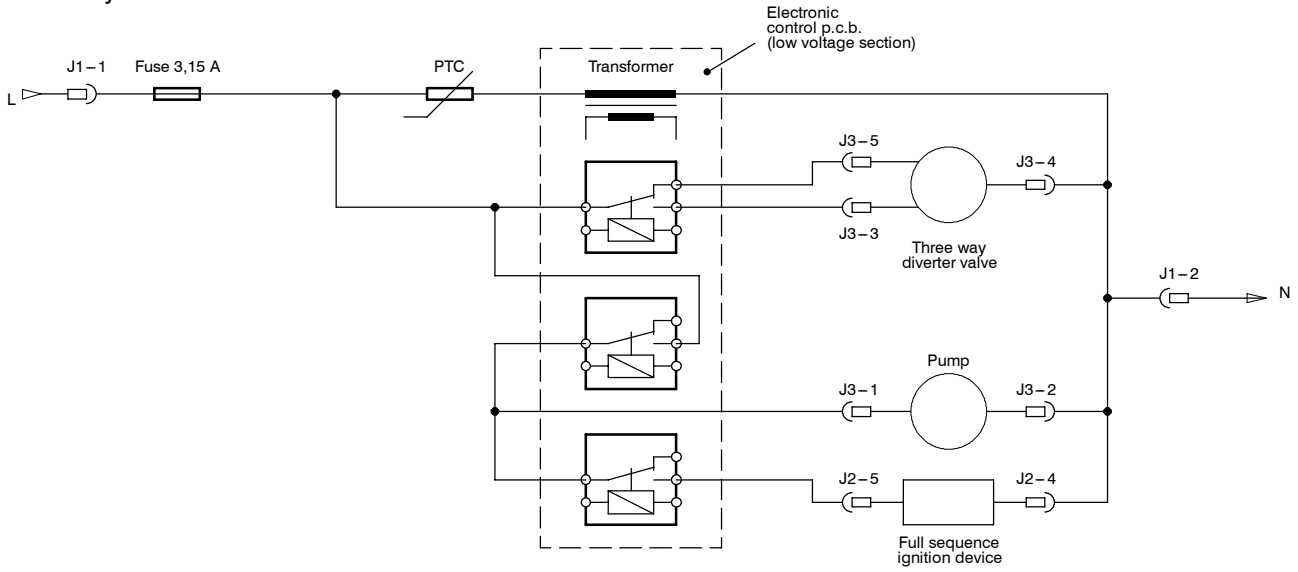

Heat request on d.h.w.

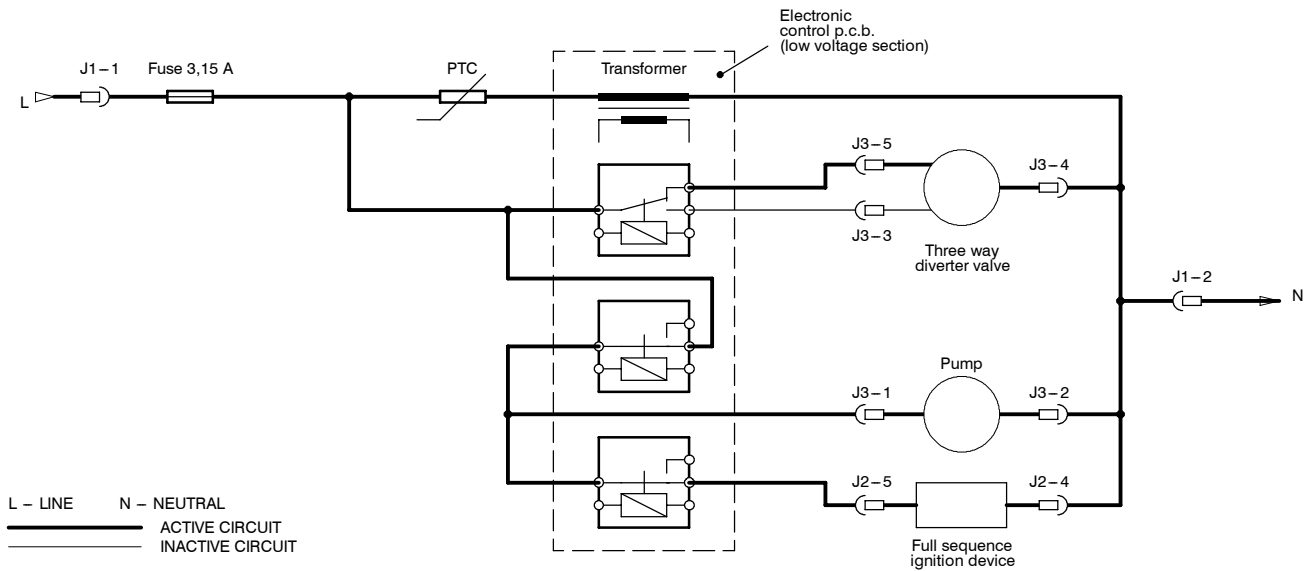

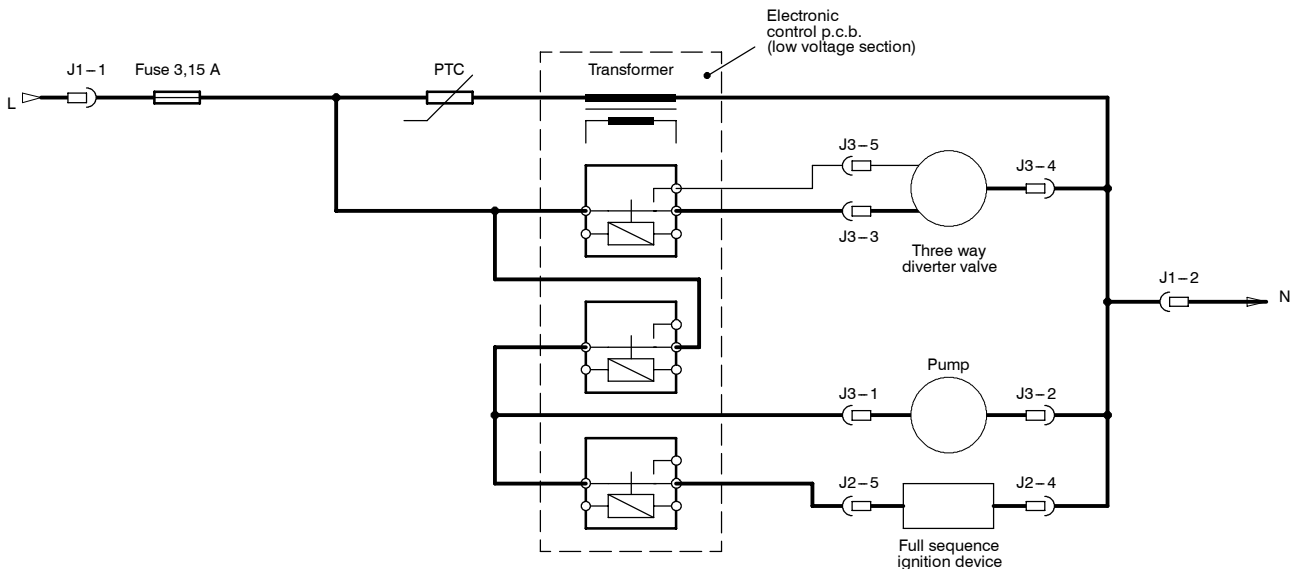

Heat request on c.h.



3.4 Circuit voltages

Electrical voltages with burner on

-  during c.h. or d.h.w. operation
-  only during **c.h.** operation
-  only during **d.h.w.** operation

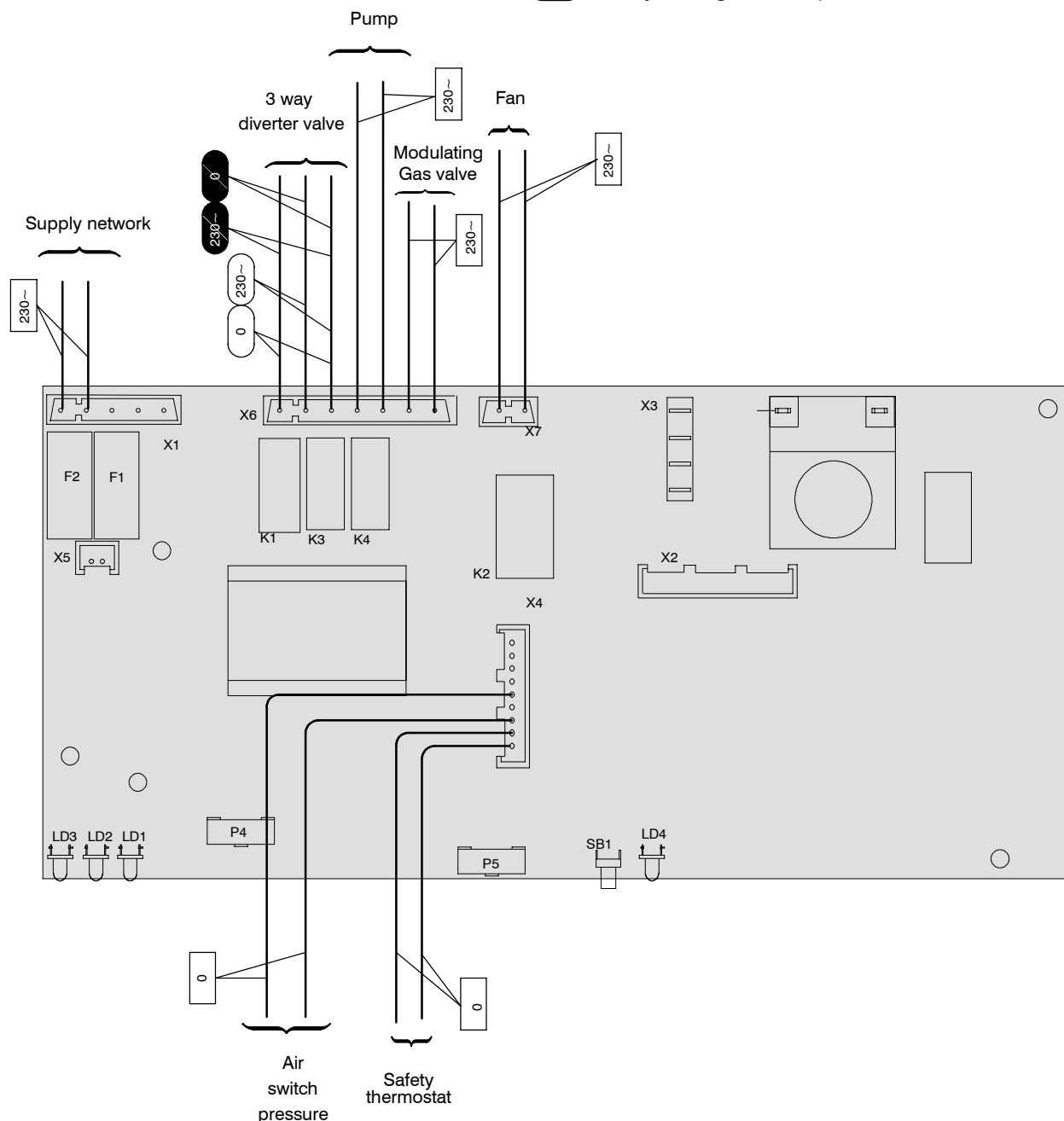

5 Primary heat exchanger

5.1 Function

The primary heat exchanger *A* in Fig. 9 has the function of transferring heat produced from combustion of the gas to the water circulating in it.

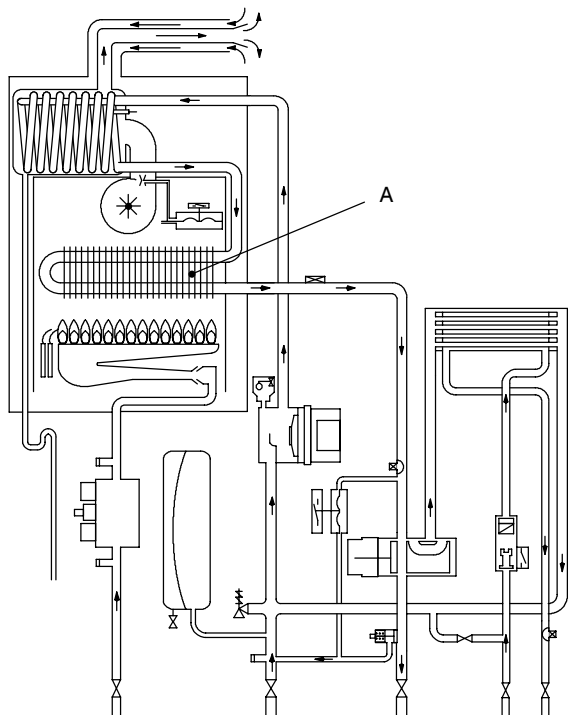

Fig. 9

The hydraulic circuit is composed of 8 elliptical pipes connected in parallel (Fig. 10).

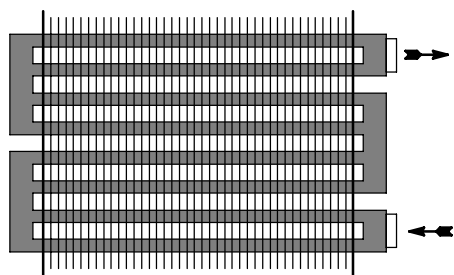

Fig. 10

5.2 Removal

Warning: isolate the boiler from the mains electricity supply before removing any covering or component.

- 1 Remove the case panels and the sealed chamber lid (see section 2).
- 2 Empty the primary circuit of the boiler.
- 3 Remove the combustion chamber lid *B* by unscrewing the screws *C* and removing the clamp *D* (Fig. 11).
- 4 Remove the screws *E* and the plate *F*.
- 5 Loosen the connection *G* and slightly move the pipe *H* upwards.
- 6 Remove the clip *I* and the safety thermostat *J*. It is not necessary to disconnect it from the wiring.

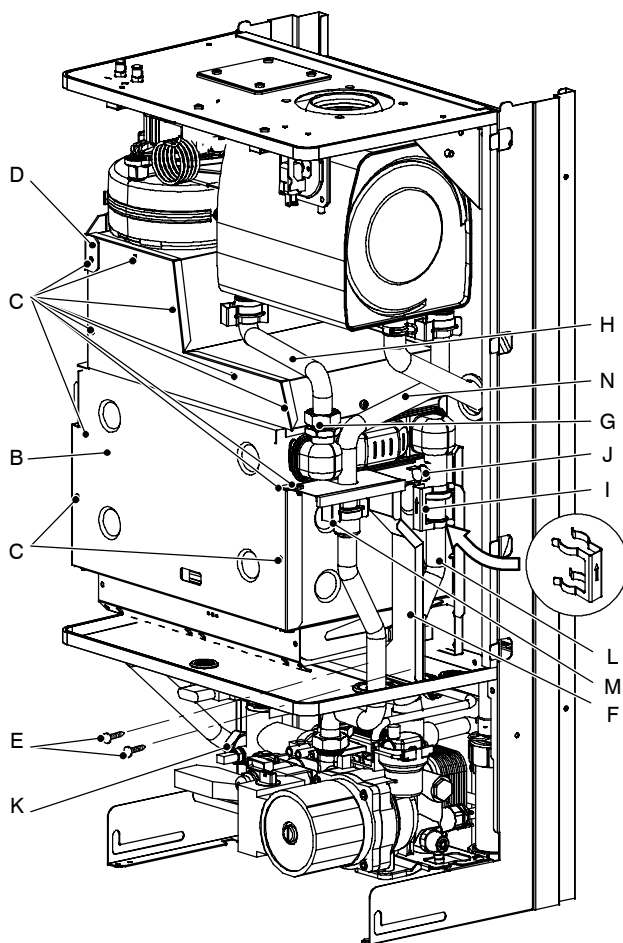

Fig. 11

- 7 Loosen the connection *K* and move the pipe *L* downwards freeing it from the connection of the primary heat exchanger.
- 8 Remove the clip *M*
- 9 Move the pipe *N* upwards freeing it from the connection and rotate towards right.
- 10 Remove the heat exchanger by sliding it forwards.
- 11 Reassemble the boiler carrying out the removal operations in reverse order. **Fit the clip *I* with the arrow pointing upwards as illustrated in Fig. 11.**

IMPORTANT – do not force the connection *G* when tightening it.

5.3 Cleaning

If there are deposits of soot or dirt between the blades of the heat exchanger, clean with a brush or non-metallic bristle brush.

In any case, avoid any actions that can damage the protective varnish with which the exchanger has been covered.



Warning: After cleaning or replacement as detailed above, if it deemed necessary to undertake a combustion analysis, refer to the appropriate chapter *Maintenance* of the installation instructions manual.

6 Condensing heat exchanger

6.1 Function

The return water flows through the condensing heat exchanger *A* in Fig. 12 and Fig. 13.

By reducing the combustion products temperature, the latent heat of the vapour is transferred to the water circuit, allowing an extra gain of useful heat.

The condensed vapour is then drained through the condensate trap *B* and the draining pipe *C*.

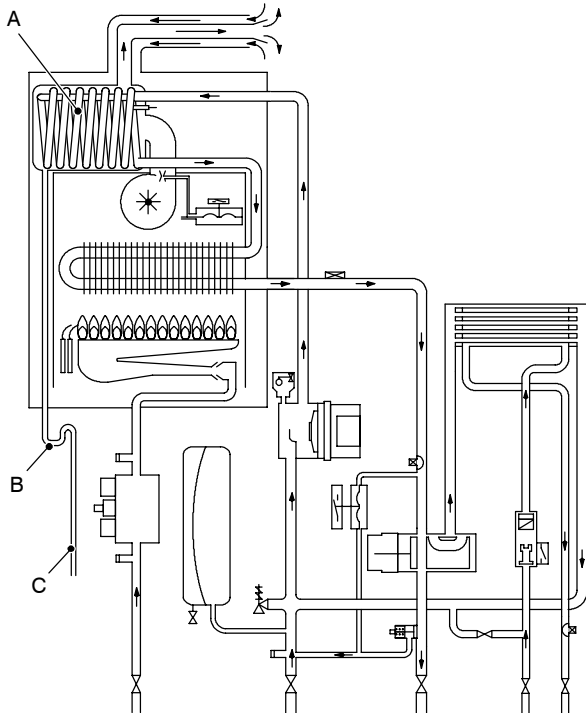

Fig. 12

6.2 Removal

Warning: isolate the boiler from the mains electricity supply before removing any covering or component.

- 1 Remove the case panels and the sealed chamber lid (see section 2).
- 2 Empty the primary circuit of the boiler.
- 3 Remove the fan *D* in Fig. 13 (see section 17.3) and the air pressure switch *E* (see section 17.5).
- 4 Remove the flue temperature probe NTC *F* (see section 20.3)
- 5 Completely loosen the connection *G* and slightly move the pipe *H* upwards.

- 6 Remove the clip *I* and move the pipe *J* downwards freeing it from the connection, then turn it towards right.
- 7 Using pliers, remove the spring *K* moving it downwards and disconnect the rubber pipe *L*.
- 8 Remove the bracket *M* by unscrewing the screws that hold it on the frame.
- 9 Rotate the exchanger as indicated by the arrow and remove it towards the front of the boiler.
- 10 Remove the clip *N* and the pipe *H*.

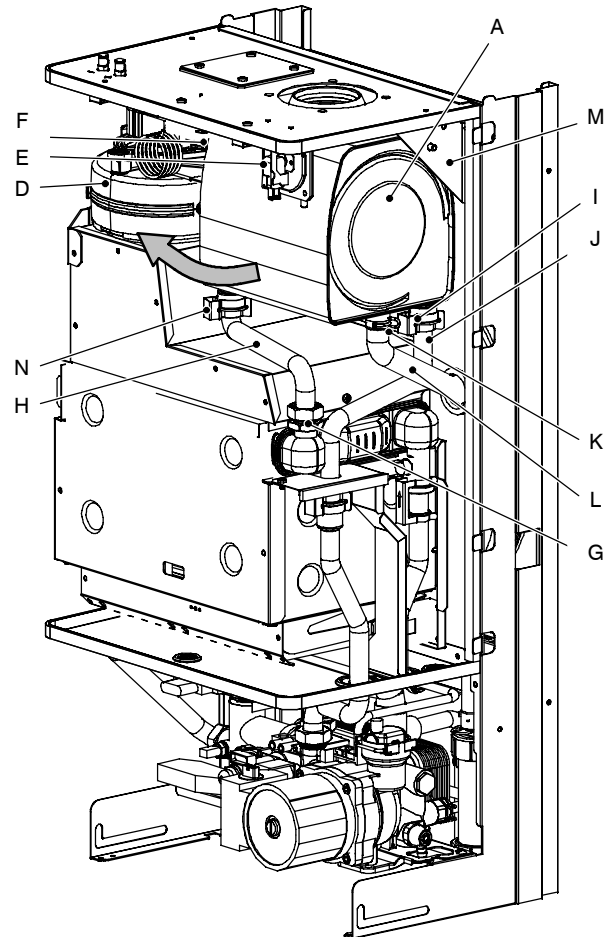

Fig. 13

- 11 Reassemble the exchanger carrying out the removal operations in reverse order.

After reassembling ensure that the fan-exchanger and exchanger-elbow gaskets are correctly mounted and ensure a good sealing.

Warning: After cleaning or replacement as detailed above, if it deemed necessary to undertake a combustion analysis, refer to the appropriate chapter *Maintenance* of the installation instructions manual.

7 D.h.w. heat exchanger

7.1 Function

The d.h.w. heat exchanger *A* in Fig. 14 and Fig. 16 allows the instantaneous transfer of heat from the primary hydraulic circuit to the water destined for d.h.w. use.

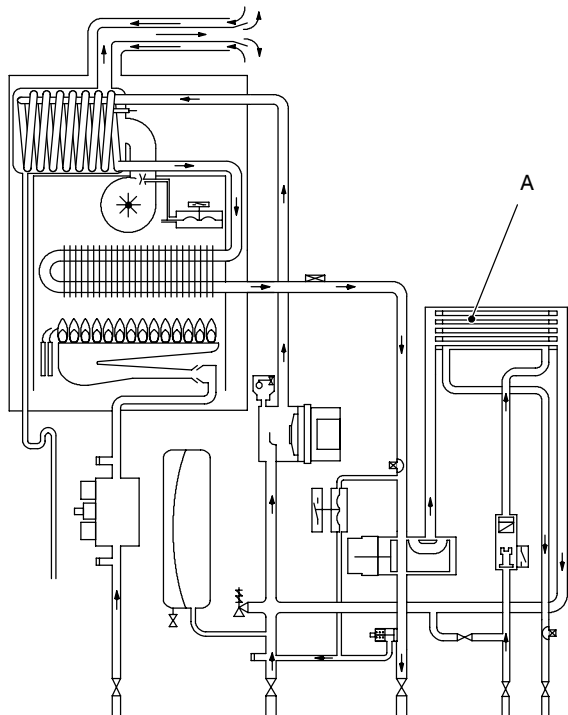
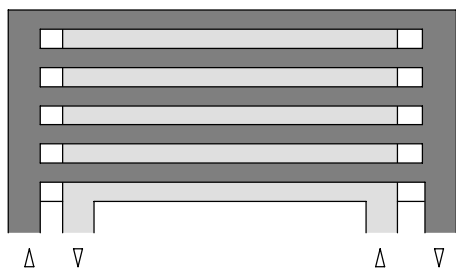

Fig. 14

The schematic structure is shown in Fig. 15.



- Primary hydraulic circuit
- Domestic hot water circuit

Fig. 15

7.2 Removal

Warning: isolate the boiler from the mains electricity supply before removing any covering or component.

- 1 Remove the front and right hand side panels of the case.
- 2 Empty the primary circuit and the d.h.w. circuit of the boiler.
- 3 Completely unscrew the two Allen key screws *B* (Fig. 16) which hold the exchanger to the brass groups.

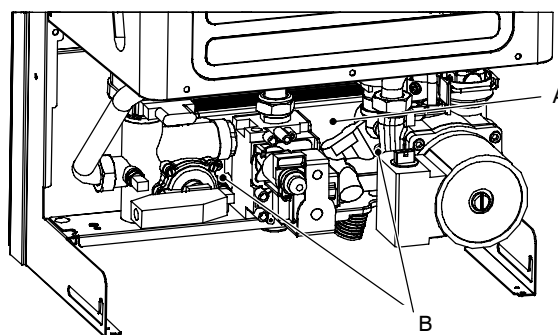

Fig. 16

- 4 Move the exchanger towards the rear of the boiler and extract it.

Reassemble the d.h.w. heat exchanger carrying out the removal operations in the reverse order.

Attention. When reassembling the exchanger be sure to put the off center location/securing pin indicated in Fig. 17 towards the left side of the boiler.

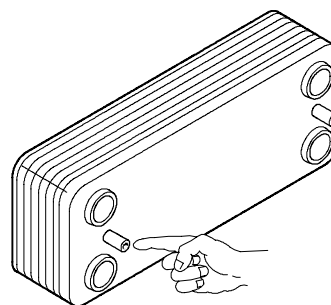

Fig. 17

8 Pump

8.1 Function

The pump *A* in Fig. 18 and Fig. 19 has the function of making the water in the main circuit circulate through the main heat exchanger, the condensing heat exchanger and therefore through the c.h. system (during the c.h. function) or through the secondary heat exchanger (during the d.h.w. function).

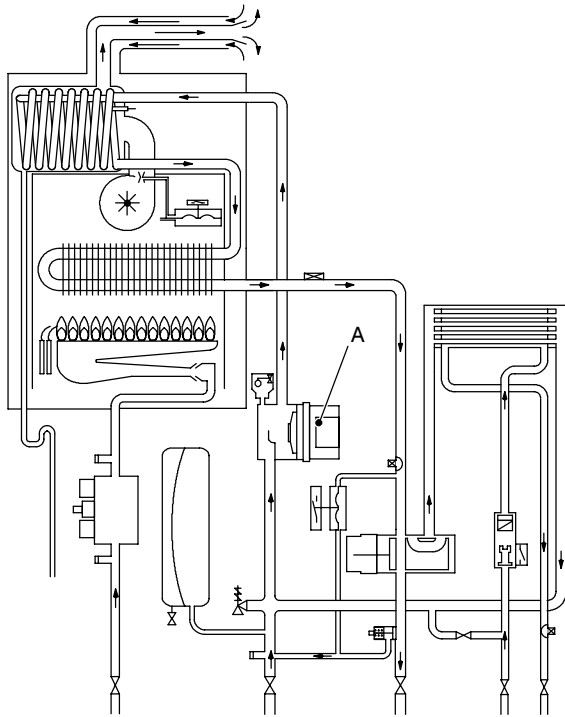

Fig. 18

8.2 Checks

Warning: isolate the boiler from the mains electricity supply before removing any covering or component.

Check that the pump is not seized and that the movement of the rotor is not subject to mechanical impediments.

With the boiler off, remove the front panel. Remove the air release plug of the pump and turn the rotor with a screwdriver.

Check the electrical continuity.

With the boiler off, remove the front panel and disconnect the connector *B* (Fig. 20).

Measure the electrical resistance between the pump supply connections.

Electrical resistance of the windings (at ambient temperature) must be about 230 Ω

Check the absence of starting defects.

With the boiler off remove the front case panel.

Remove the air release plug from the pump. Start the boiler and with a screwdriver, turn the rotor in the direction of the arrow. If there is a defect in starting, the rotor will begin to turn normally only starting it manually.

Check that the impeller is integral with the rotor. With the boiler off remove the front and right hand side case panels, lower the control panel and empty the primary circuit.

Remove the pump head by undoing the screws which hold it to the pump body and check that the impeller is firmly joined to the rotor.

8.3 Removal

Warning: isolate the boiler from the mains electricity supply before removing any covering or component.

- 1 Remove the front and right hand side case panels
- 2 Empty the primary circuit of the boiler.
- 3 Extract and lower the control panel.
- 4 Disconnect the connector *B* (Fig. 19).
- 5 Loosen the connection *C*, and pull up and turn to the left the pipe *D*.

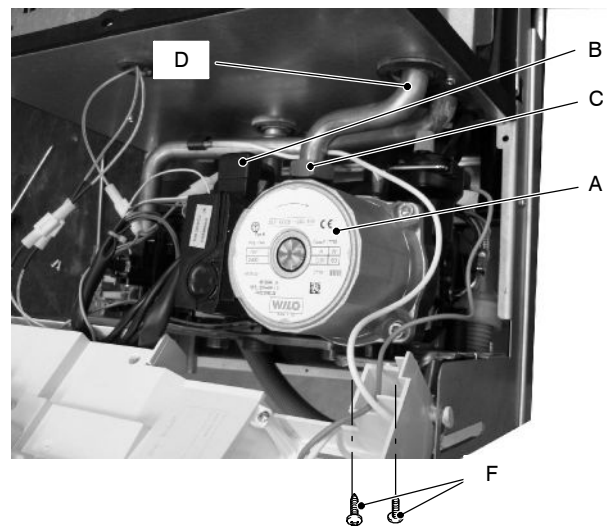

Fig. 19

- 6 Remove the locking plate *E* (Fig. 20).
- 7 Unscrew the two screws *F* that hold the pump on the frame and remove the pump.

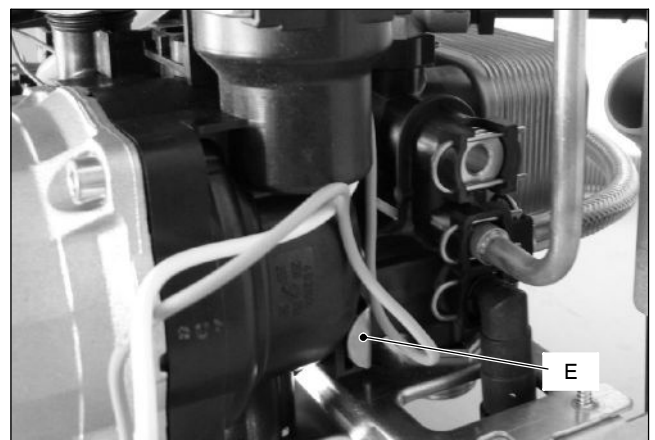

Fig. 20

Reassemble the pump carrying out the removal operations in the reverse order. When reassembling the pump, check the correct location of the O-ring gasket in the inlet port of the pump that seals the connection between the pump and the brass group.

9 Three way diverter valve

9.1 Function

The diverter valve A (Fig. 21) has the function of modifying the hydraulic circuit of the boiler by means of an electric command given by the electronic control p.c.b. in order to send the water that exits the primary heat exchanger towards the c.h. system or towards the d.h.w. heat exchanger.

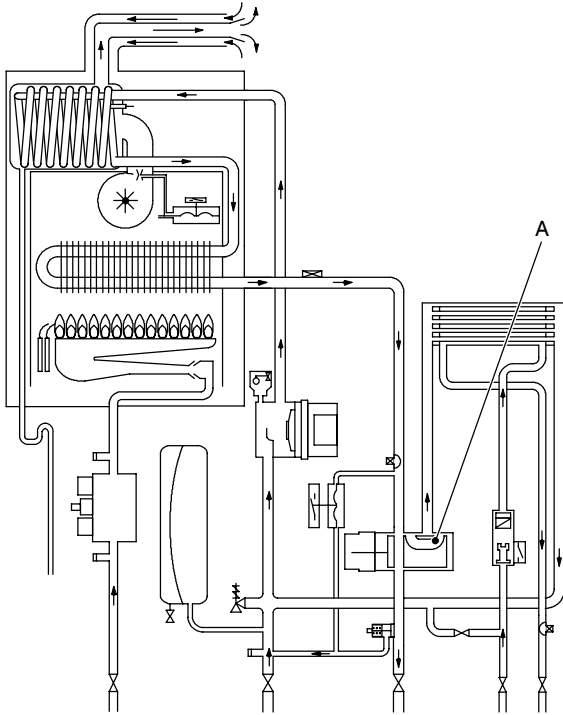

Fig. 21

9.2 Checks

✓ Check the electrical continuity

Fig. 22 indicates the relationship between the electric command coming from the electronic control p.c.b. and the position of the actuator B (brass spindle) when the boiler operates in **d.h.w. mode**.

Fig. 23 indicates the relationship between the electric command coming from the electronic control p.c.b. and the position of the actuator B (brass spindle) when the boiler operates in **c.h. mode**.

In both figures the relationship between the position of the actuator and the resistance of the motor windings (the motor must be disconnected from the wiring) is also given.

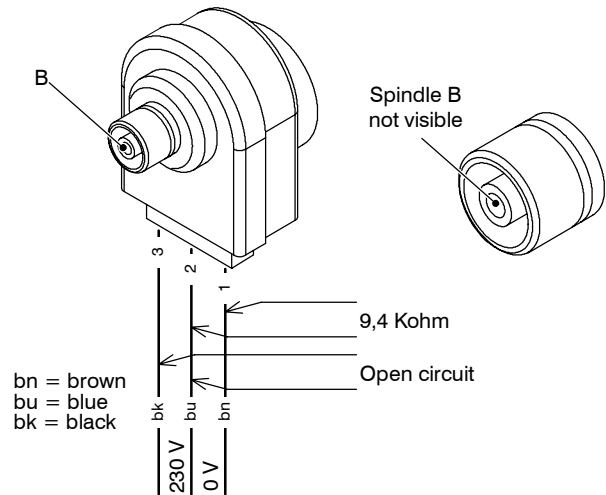

Fig. 22 – D.h.w. mode

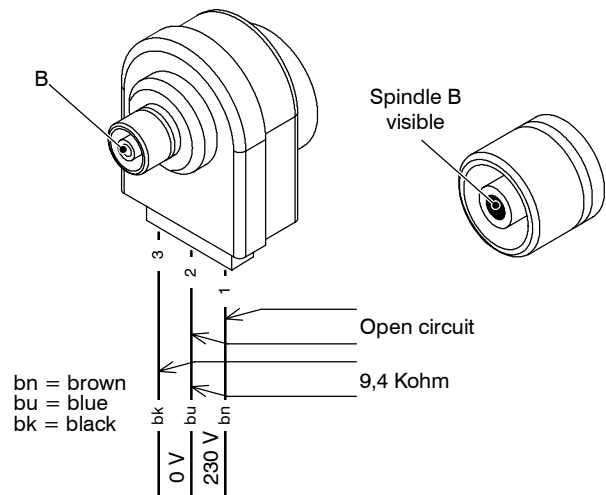

Fig. 23 – C.h. mode

9.3 Removal of the electric actuator

⚡ **Warning: isolate the boiler from the mains electricity supply before removing any covering or component.**

- 1 Remove the front case panel.
- 2 Disconnect the connectors C (Fig. 24).
- 3 Remove the fixing spring D and remove the actuator E.
Reassemble the actuator carrying out the removal operations in the reverse order.
When reassembling the actuator, refer to Fig. 22 or to the wiring diagram in section 9.2 for the correct wiring connection.

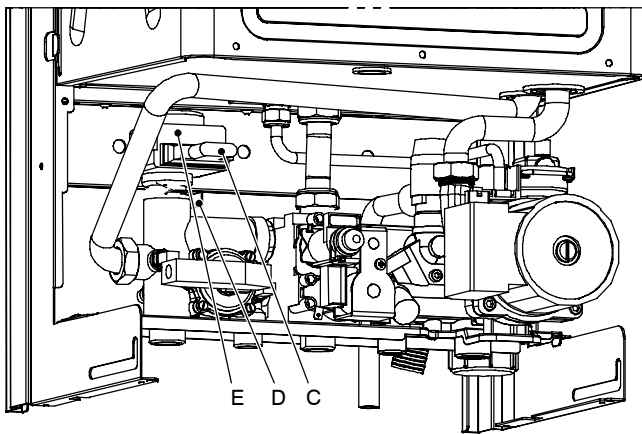

Fig. 24

9.4 Removal of the diverter group and its internal parts

- 1 Remove the front and both side case panels.
- 2 Empty the primary circuit and the d.h.w circuit of the boiler.
- 3 Remove the electric actuator (see section 9.3).
- 4 Remove the fixing spring *F* (Fig. 25) and remove the primary circuit flow switch *G*.
- 5 Disconnect both c.h. and d.h.w. temperature probe, respectively *H* and *I*.
- 6 Unscrew the connector *J*, the c.h. flow connector and the d.h.w. outlet connector.

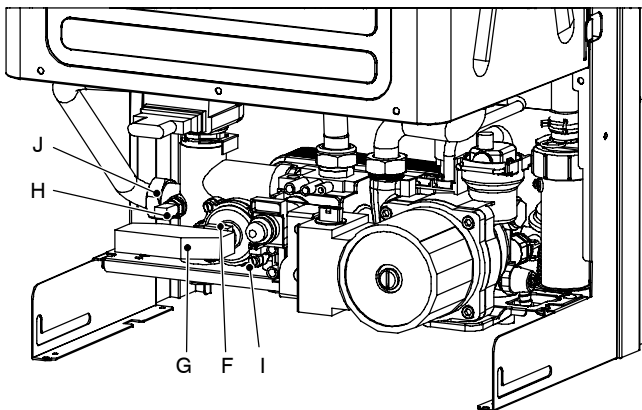

Fig. 25

- 7 Remove the d.h.w. heat exchanger (see section 7.2).
- 8 Remove the fork *K* and move away the pipe *L* (Fig. 26).

- 9 Unscrew the screw *M* and remove the diverter group.

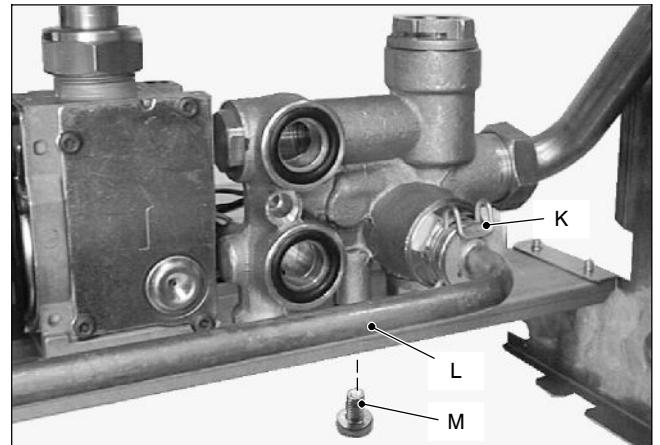

Fig. 26 Rear view of the boiler

- 10 Refer to the exploded view in Fig. 27 to remove the internal parts of the three way diverter valve.

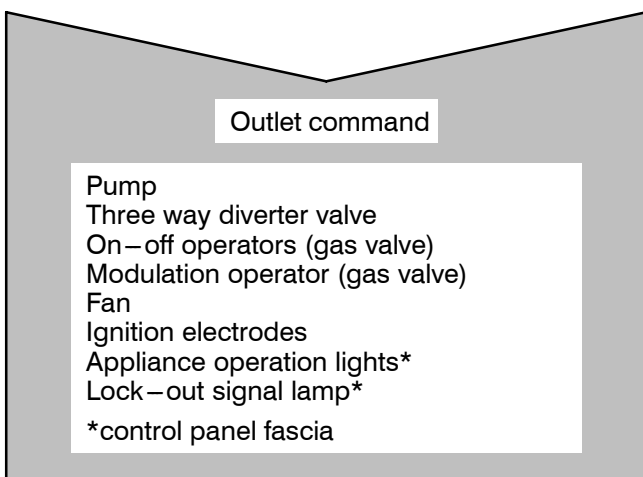
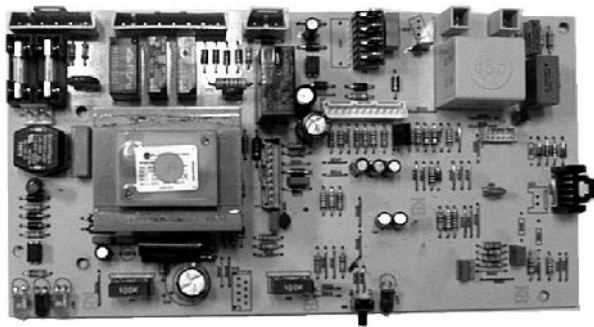
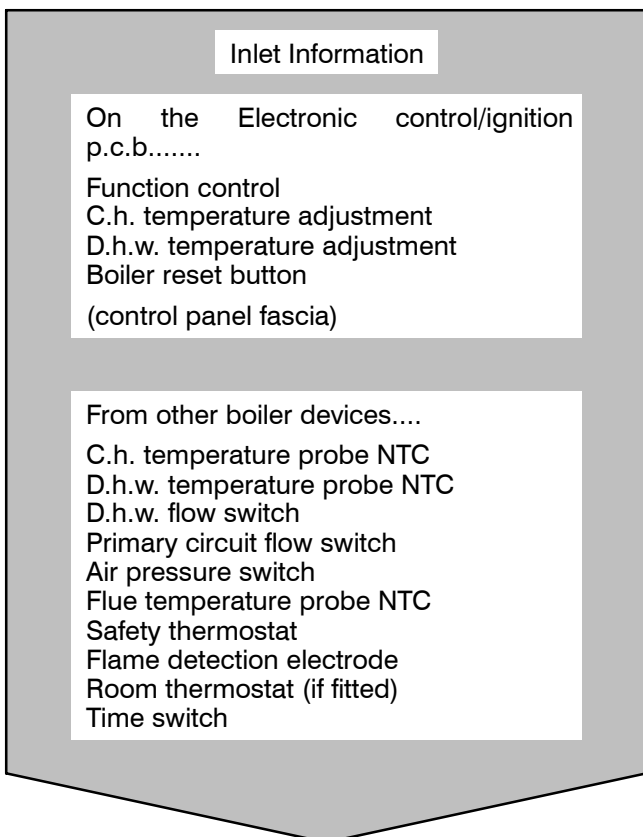

Fig. 27

- 11 Reassemble the diverter group carrying out the removal operations in the reverse order.

10 Electronic control/ignition p.c.b.

10.1 Function



The fundamental function of the Electronic control/ignition p.c.b. is that of controlling the boiler in relation to the external needs (i.e. heating the dwelling or heating the water for d.h.w. use) and operating in order to keep the temperature of the hydraulic circuits constant.

This is obviously possible within the useful power and maximum working temperature limits foreseen.

Generally, the Electronic control/ignition p.c.b. receives inlet information coming from the boiler (the sensors) or from the outside (knobs, room thermostat, etc.), processes it and consequently acts with outlet commands on other components of the boiler (Fig. 28).

The Electronic control/ignition p.c.b. is also a full sequence ignition device and does a sequence of operations (ignition cycle) which lead to the ignition of the gas at the burner

It checks the presence of the flame during the entire period in which it is activated, supplies the fan and checks its functioning by means of the signal coming from the air pressure switch.

The Electronic control/ignition p.c.b. has a **safety function** and any incorrect interventions or tampering can result in conditions of dangerous functioning of the boiler.

The Electronic control/ignition p.c.b. can lock the functioning of the boiler (lock state) and stop its functioning up to the resetting intervention. The lock is signalled by the lighting of the lock-out signal lamp and the device can be reset only by using the boiler reset button placed on the control panel fascia.

Some components which are connected to the device can activate the lock state. The causes of a lock state could be:

- The intervention of the safety thermostat (overheat of the primary circuit).
- The intervention of the flue temperature probe (overheat of the combustion products).
- A fault on gas supply.
- Faulty ignition (faulty ignition electrodes, their wiring or connection).
- Faulty flame detection (faulty detection electrode, its wiring or connection).
- Faulty condensate drainage.
- Gas injectors blocked.
- Faulty modulation gas valve (faulty on-off operators or not electrically supplied).
- Faulty Electronic control/ignition p.c.b..

Other components like the air pressure switch can temporarily stop the ignition of the burner but allow its ignition when the cause of the intervention has stopped.

Fig. 52 shows the sequence of the operations that are carried out at the start of every ignition cycle and during normal functioning.

10.2 Selection and adjustment devices

On the Electronic control/ignition p.c.b. several selection, adjustment and protection devices are located. (Fig. 29).

Fig. 28

Some of these devices are directly accessible by the user (function control, temperature adjustment potentiometers etc.) others are accessible by removing the service panel or the control panel lid.

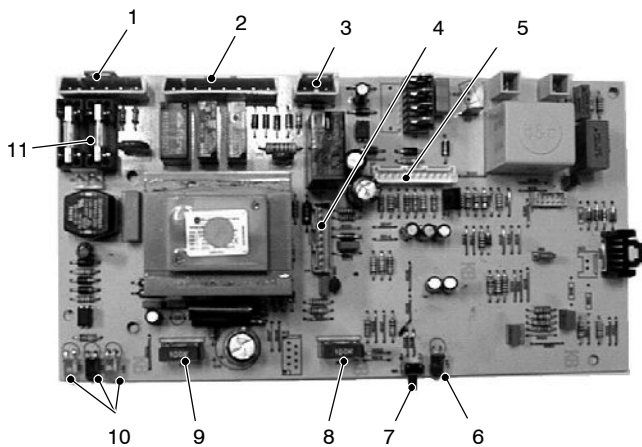

Fig. 29

- 1 x1 connector
- 2 x6 connector
- 3 x7 connector
- 4 x4 connector
- 5 x2 connector
- 6 Lock-out signal lamp
- 7 Boiler reset button
- 8 Function control / C.h. temperature adjustment
- 9 D.h.w. temperature adjustment
- 10 Appliance operation lights
- 11 Fuse 3,15 A F

10.3 Checking the temperature

The Electronic control/ignition p.c.b. makes it possible to separately adjust the c.h. water flow temperature and d.h.w. outlet temperature.

The temperature of the water is converted into an electric signal by means of temperature probes.

The user, setting the desired temperature with the control panel knobs operates the variable elements (8 and 9 in Fig. 29) of the electronic control p.c.b.

If the power requested is lower than 40% of the maximum power output then control is achieved by switching ON the burner at minimum power, then switching OFF (ON/OFF function). If the power requested is higher, then the burner is switched ON at maximum power and will control by modulating to 40% of the maximum power output.

During the c.h. operation (Fig. 30), the signal coming from the c.h. temperature probe is compared to the signal given by the control panel through the adjustment made by the user (knob ). The result of such a comparison operates the modulation of the gas valve, consequently changing the useful output of the boiler.

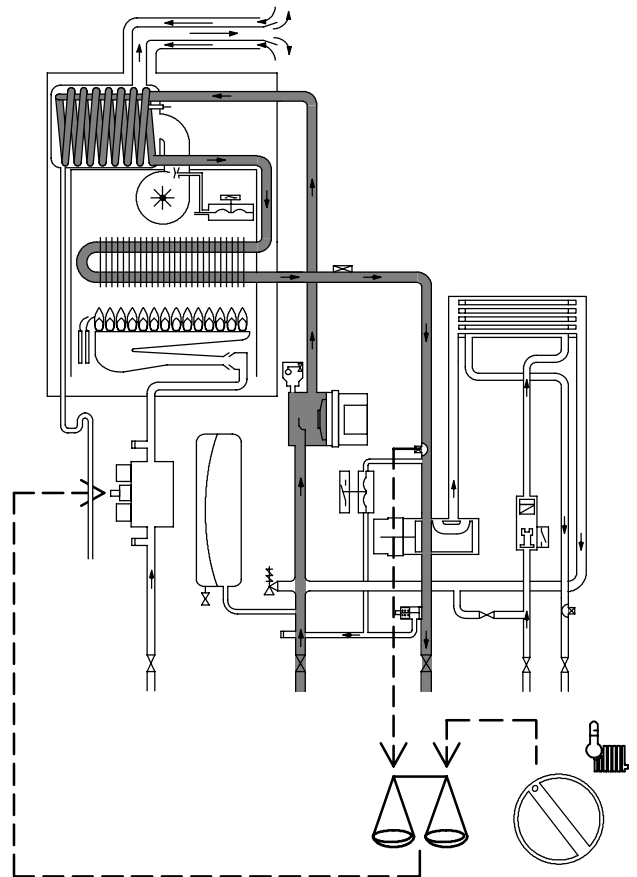



Fig. 30

When the boiler functions in d.h.w. (Fig. 31), the signal coming from the d.h.w. temperature probe is compared with the signal given by the control panel through the adjustment made by the user (knob ).

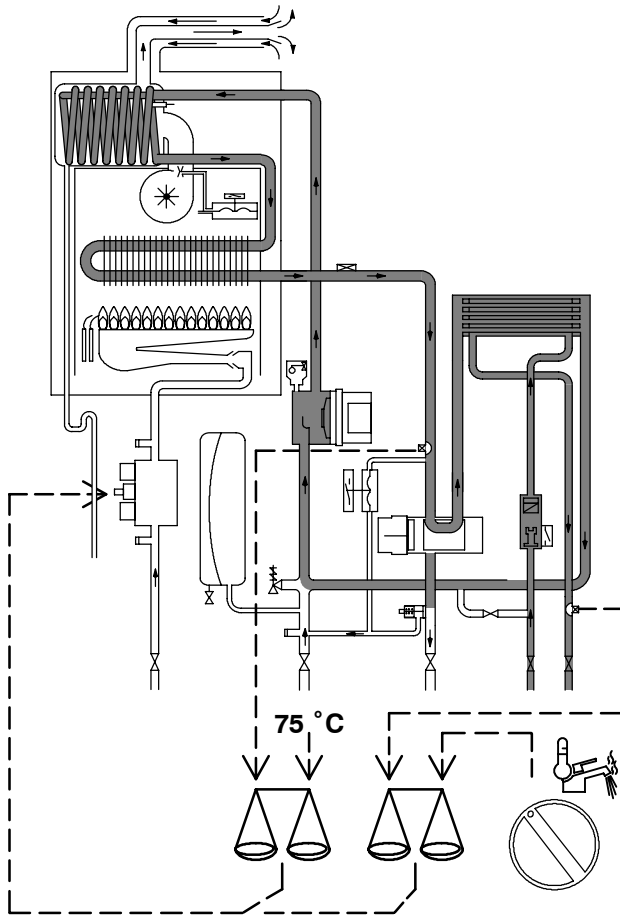

Fig. 31

Normally, the result of the comparison between these two signals directly operates the adjustment elements of the gas valve modulation device, adjusting the useful output generated in order to stabilize the temperature of the exiting water.

If during the d.h.w. mode operation, the temperature of the primary circuit goes over 75°C, the useful output is automatically reduced so that the primary circuit cannot reach excessive temperatures.

The control sequences in ❄️ function and in ☀️ function are illustrated in detail in sections 10.11 and 10.12.

10.4 Operation lights

The Electronic control/ignition p.c.b. is provided with three lamps (L.E.D. indicators) 10 in Fig. 29 that give optical information during the operation of the boiler.

The green lamp on the left gives information whether the boiler is in stand-by mode or during the normal operation of the boiler.

The following table gives the relationship between the lamp indication and its meaning.

<p>A short pulse every 4 seconds</p>	<p>Boiler in stand-by condition. (function control in ⏻ position). Anti-freeze system active.</p>
<p>1 second ON 1 second OFF</p>	<p>Boiler ON condition (function control in ❄️ or ☀️ position)</p>

With the boiler switched ON (☀️ or ❄️) all the lamps (10 in Fig. 29) are activated.

The following table gives the relationship between each of the possible lamp combinations and their meaning.

			Normally operating boiler (see the previous table for details)
			C.h. operation
			D.h.w. operation
			Frost protect operation
			D.h.w. operation Excessive temperature on primary circuit
			Faulty c.h. temperature probe NTC
			Faulty d.h.w temperature probe NTC
			Faulty flue temperature probe NTC
			Faulty primary circuit (no water or absence of flow)
			Faulty air pressure switch
			Lack of burner ignition (no ignition signal from the full sequence ignition device)
			Safety thermostat lock out
			Flue temperature probe NTC lock out
			Lack of power supply or faulty electronic control p.c.b. *
			Faulty Electronic control/ignition p.c.b.. *
			Lamp OFF
			Lamp ON
			Flashing lamp, alone or simultaneously with an other lamp.
			Flashing lamp, alternate with another lamp.

* These conditions are normal only for a short time when the power supply is applied to the boiler. If permanent they indicate a faulty p.c.b.

10.5 Setting the boiler control function modes

It is possible to select the various boiler control function modes by using the function selector knob A and the D.h.w. temperature control knob B (Fig. 32).

On model M96.28SR/... or M96.24SR/... the knob B is used just for boiler setting and doesn't affect the boiler functions during the normal operation.

During the function modes setting, the boiler does not operate.

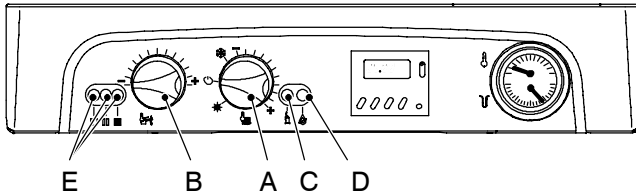

Fig. 32

10.6 Reignition frequency setting

It is possible to select the minimum time that must pass between two ignitions of the burner in c.h. function mode.

- 1 Turn the boiler ON positioning the function selector knob A as indicated in Fig. 33.

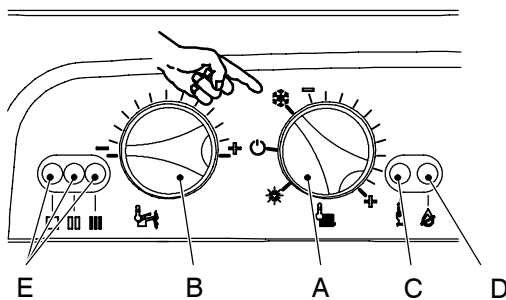

Fig. 33

- 2 Keep pressed the reset button C for about 10 seconds until the lock-out signal lamp D blinks.
- 3 The lamps E should give the indication as in Fig. 34 (reignition frequency). If not, press the reset button repeatedly to obtain it.

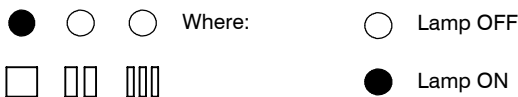

Fig. 34

At this step it is possible to visualize the current setting by keeping the reset button C pressed for more than 5 seconds. The lamps E will flash a number of times corresponding to the setting (Fig. 35).

- 4 To change the setting turn the knob B on a position corresponding to the desired delay. By turning the knob B, the lock-out signal lamp D blinks quickly (2 per seconds) indicating that the setting has changed and must be memorised.

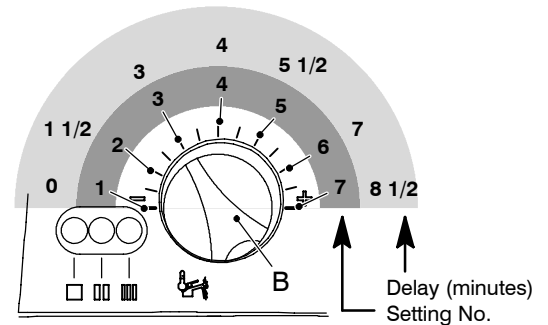

Fig. 35

- 5 To memorize the setting keep pressed the reset button C for about 5 seconds until the lights E briefly blinks simultaneously.
- 6 To reset the boiler to the normal operation turn it OFF and ON by the function selector knob A. In any case, the boiler automatically resets to its normal operation after 10 minutes.

Factory setting = 3minutes

10.7 Combi / C.H. only mode setting

Two different options are available on the Electronic control/ignition p.c.b. and proper setting must be done after a replacement of the p.c.b.

- 1 Remove the front panel of the case.
- 2 Turn ON the power supply. Lamps E give the indication as in Fig. 36.

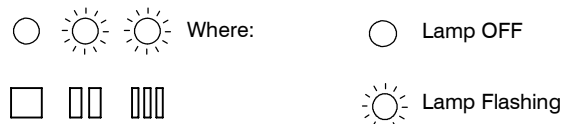

Fig. 36

- 3 Position the function selector A as in Fig. 37 and disconnect the C.h. temperature probe.
- 4 Keep pressed the reset button C for about 10 seconds (Fig. 37) until the lock-out signal lamp D blinks.
- 5 Connect the c.h. temperature probe.

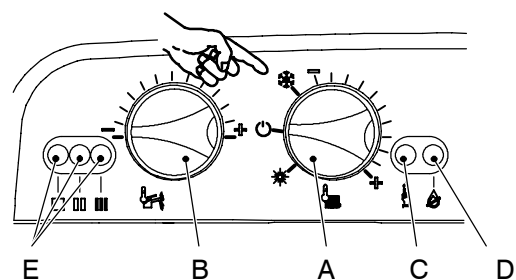

Fig. 37

- 6 Press the reset button C repeatedly (2 times) until the lamps E give the indication as in Fig. 38 (boiler mode).

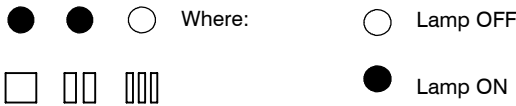

Fig. 38

At this step it is possible to visualize the current setting by keeping the reset button C pressed for more than 5 seconds. The lamps E will flash a number of times corresponding to the setting (Fig. 39).

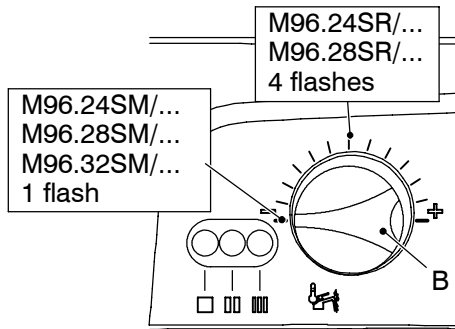

Fig. 39

- 7 To change the setting turn the knob B on a position corresponding to the boiler models (Fig. 39). By turning the knob B, the lock-out signal lamp D blinks quickly (2 per seconds) indicating that the setting has changed and must be memorised.
- 8 To memorize the setting keep pressed the reset button C for about 5 seconds until the lights E briefly blinks simultaneously.
- 9 Press the reset button C once until the lamps E give the indication as in Fig. 40 (boiler mode).

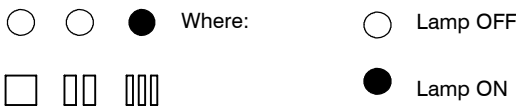

Fig. 40

It's now possible to check the current setting by pressing reset button C for more than 5 seconds. The three lamps E will flash a number of times corresponding to the setting as in Fig. 41 (once for the combination and four times for system boilers). At this point only the right green light flashes.

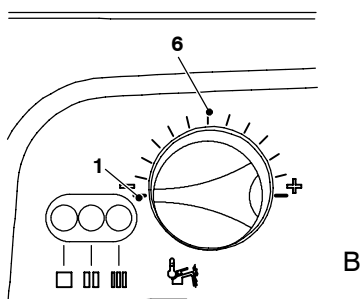

Fig. 41

- 10 Turn the water control to minimum. Lock-out lamp blinks (2 per second) indicating the setting has changed

- 11 To change the setting turn the knob B on a position corresponding to the boiler model (Fig. 41).
- 12 To memorize the setting keep pressed the reset button C for about 5 seconds until the lights E briefly blinks simultaneously. At this point only the right green light flashes.
- 13 To reset the boiler to the normal operation turn it OFF and ON by the function selector knob A.

10.8 Ignition gas pressure adjustment

- 1 Turn the boiler OFF.
- 2 Remove the front panel of the case.
- 3 Open the gas valve outlet pressure test point (7, see section 11.2) and connect the gauge.
- 4 Turn the boiler ON positioning the function selector knob A as indicated in Fig. 42 (M96.24SM/..., M96.28SM/..., M96.32SM/...) or Fig. 43 (M96.28SR/...,). and ensure that the timer selector switch and room thermostat, if fitted, are set to "heat demand".
Run the boiler in c.h. mode (do not open any d.h.w. tap).

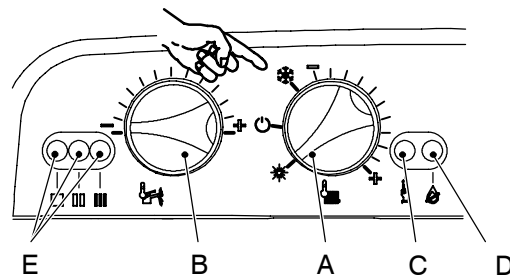

Fig. 42

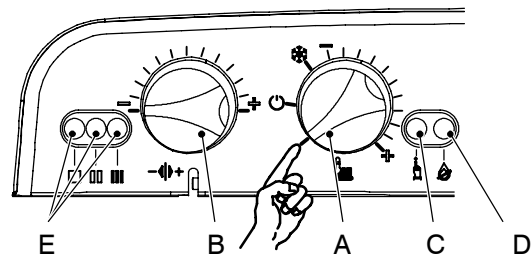

Fig. 43

- 5 Keep pressed the reset button C for about 10 seconds until the lock-out signal lamp D blinks.
- 6 The lamps E should give the indication as in Fig. 44. If not, press the reset button repeatedly to obtain it.

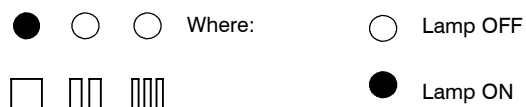

Fig. 44

- 7 Keep pressed the reset button C for about 5 seconds until the lock-out signal lamp D is switched OFF.
The boiler runs in c.h. mode and the lamps E give the indication as in Fig. 45.

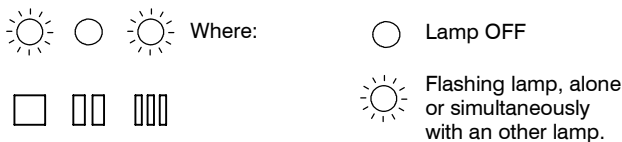

Fig. 45

- 8 Rotate the knob B on a position corresponding to an adequate ignition pressure. Refer to the value indicated in the tables of the User/Installation manual (*Technical information* section, *Gas pressures at the burner* table). By rotating clockwise the pressure increases.
- 9 Make a note of the position of the knob B.
- 10 Turn the boiler OFF and ON positioning the function selector knob A as indicated in Fig. 46

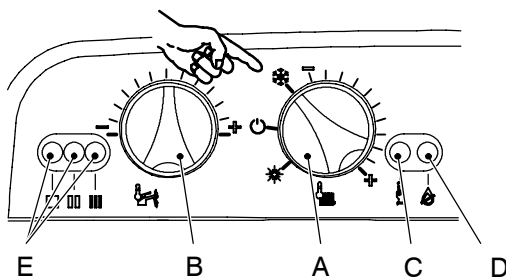

Fig. 46

- 11 Keep pressed the reset button C for about 10 seconds until the lock-out signal lamp D blinks.
- 12 Press the reset button C repeatedly (4 times) until the lamps E give the indication as in Fig. 47 (ignition pressure adjustment mode).

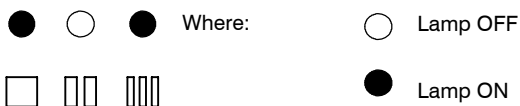

Fig. 47

- 13 Turn the knob B to the minimum (fully counter-clockwise) and then on the position corresponding to the position obtained on step 8. By turning the knob B, the lock-out signal lamp D blinks quickly (2 per second) indicating that the setting has changed and must be memorised.
- 14 To memorize the setting keep pressed the reset button C for about 5 seconds until the lights E briefly blinks simultaneously.
- 15 To reset the boiler to the normal operation turn it OFF and ON by the function selector knob A checking the ignition pressure and that the burner lights up uniformly. In any case, the boiler automatically resets to its normal operation after 10 minutes.

10.9 Checks

- ✓ Check that the fuses are complete

If the Electronic control/ignition p.c.b. does not supply any device (pump, fan, etc.) check that the fuses 11 (Fig. 29) are complete.

If a fuse has blown replace it with one that has the same characteristics after having identified the reason for failure.

- ✓ Lock sequence

Start the boiler until the burner is ignited.

With the burner firing, interrupt the gas supply. The Electronic control/ignition p.c.b. must carry out three complete ignition cycles and then, after about 3 minutes, goes to lock-out state.

By turning the boiler on and off by means of the function switch the device must not unlock and the burner must not turn on.

- ✓ Fan functioning device

With the boiler operating and the burner on, open the negative pressure test point of the Venturi device. At the moment of opening the burner must turn off.

10.10 Removal of the electronic control p.c.b

Warning: isolate the boiler from the mains electricity supply before removing any covering or component.

When replacing the Electronic control/ignition p.c.b. it is advisable to go through the setting modes of the boiler

- 1 Gain access to the parts located inside the control panel as explained in the section 2.3 of this manual.
- 2 Remove all the wiring connected to the Electronic control/ignition p.c.b.. To disconnect the connectors x1, x6 and x7 (1, 2 and 3 in Fig. 29) delicately flex the hook present on one side of each socket. To disconnect the connectors x4 and x2 (4 and 5 in Fig. 29) press delicately the hook present on one side of each connector.
- 3 Remove the spindles of the c.h. and d.h.w. temperature adjustment knobs by delicately pulling them with pliers in the direction shown by the arrows in Fig. 48.

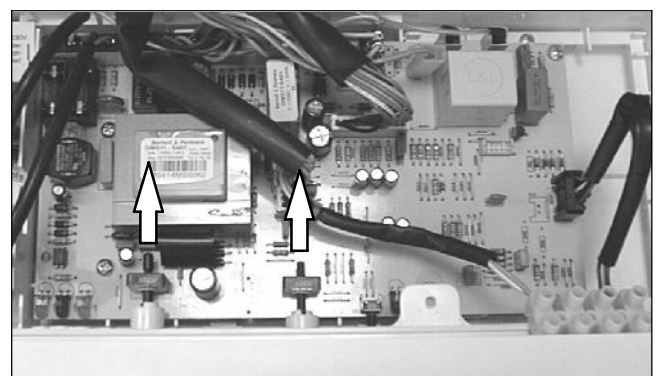

Fig. 48

- 4 Unscrew the four screws that hold the Electronic control/ignition p.c.b. on to the control panel.
- 5 Remove it by lifting its rear edge and freeing it from any of the wiring.
- 6 Re-assemble the Electronic control/ignition p.c.b. following the removal procedures in the reverse order.

Important

When re-assembling the Electronic control/ignition p.c.b.:

- 7 Fit the p.c.b. into the control panel by first inserting the front lower edge under the control knob shafts. Lower the rear edge and ensure that no wiring is trapped beneath.
- 8 Insert the spindles in the control panel knobs until the notch *A* (Fig. 49) reaches the potentiometer edge. It is not necessary to force them in the knob.
- 9 While tightening the screws that fix the Electronic control/ignition p.c.b. on the control panel, keep the p.c.b. towards the control panel fascia making sure of the contact between the boiler reset button *B* and the tab *C* (Fig. 49).

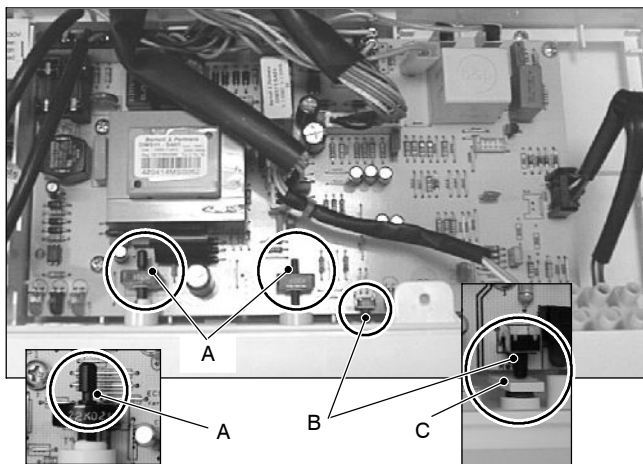

Fig. 49

Attention

After installing the Electronic control/ignition p.c.b. :

- 10 Make sure the c.h. (🔌) and d.h.w. (🔌) temperature adjustment knobs can move freely for the complete range.
If not, remove the spindle again as described at step 3, turn the knob half a turn and re-insert the spindle.
- 11 Make sure that the settings comply with the indications given in section 10.7.
- 12 Operate the boiler and close the gas inlet cock so that the boiler goes into the safety lock-out state. Verify the correct operation of the boiler reset button by pressing and releasing it.



Warning: After cleaning or replacement as detailed above, if it deemed necessary to undertake a combustion analysis, refer to the appropriate chapter *Maintenance* of the installation instructions manual.

10.11 Thermal control in the "❄️" mode

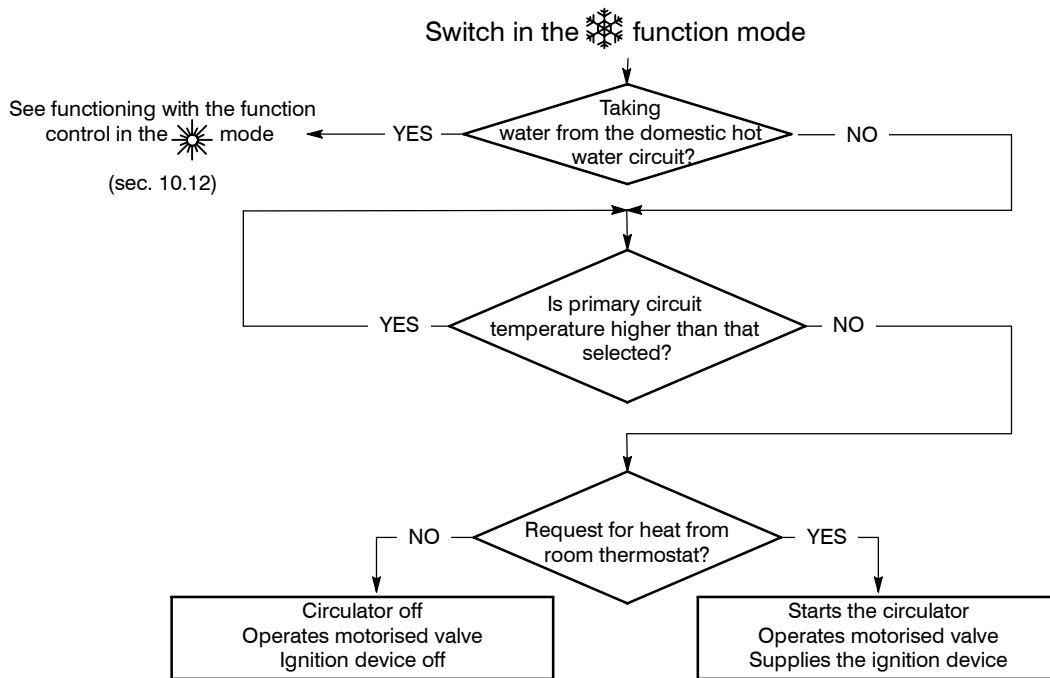

Fig. 50

10.12 Thermal control in the "☀️" mode

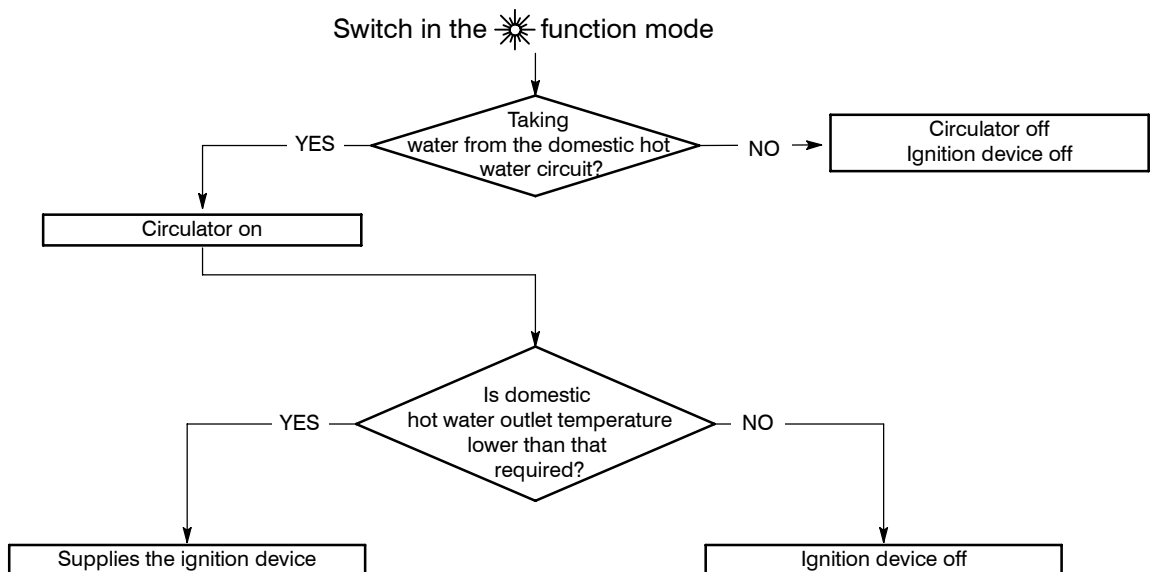

Fig. 51

10.13 Ignition and control sequence

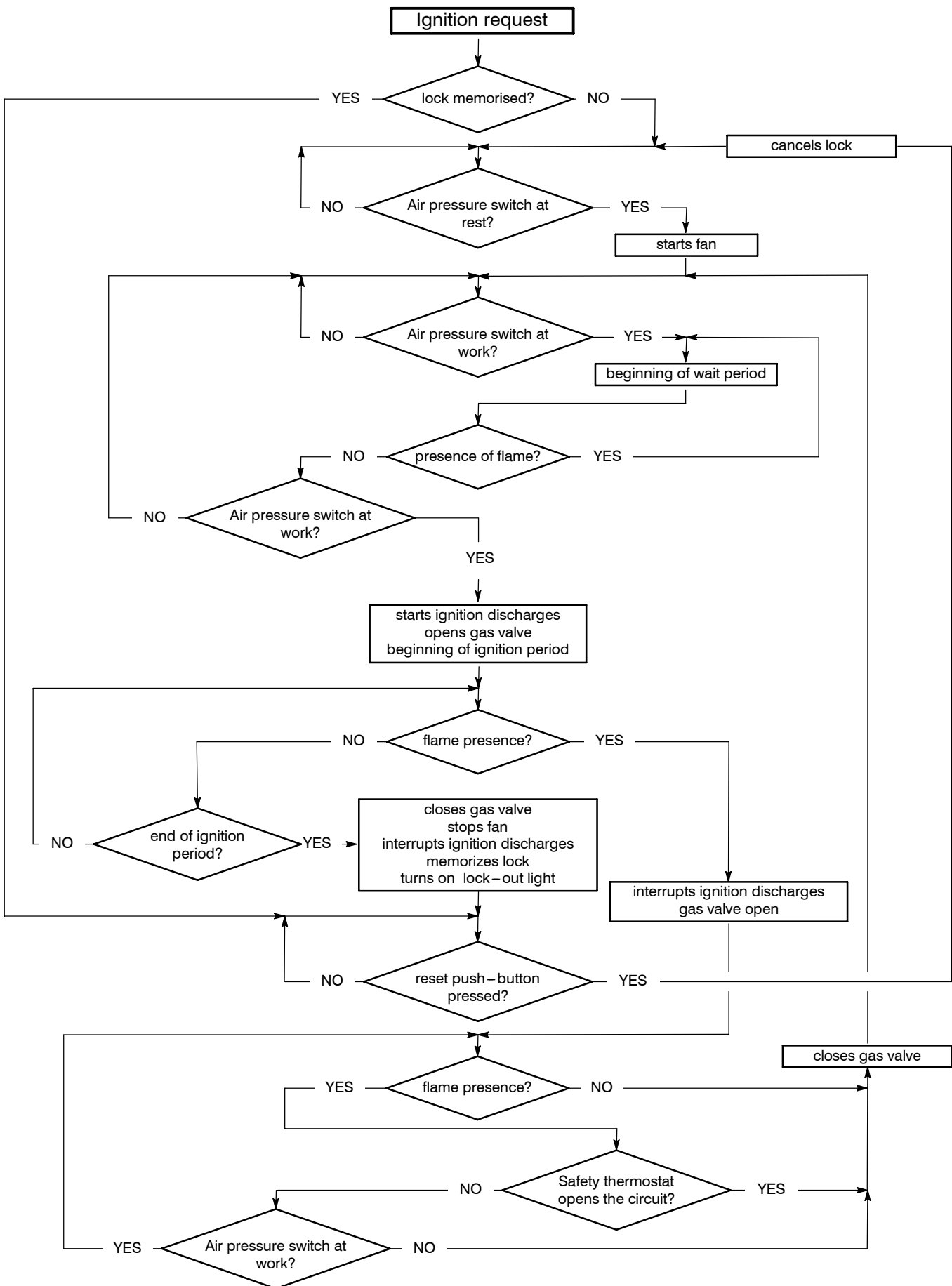

Fig. 52

11 Modulating gas valve

11.1 Function

The Modulating gas valve A in Fig. 53 controls the gas inflow to the boiler burner.

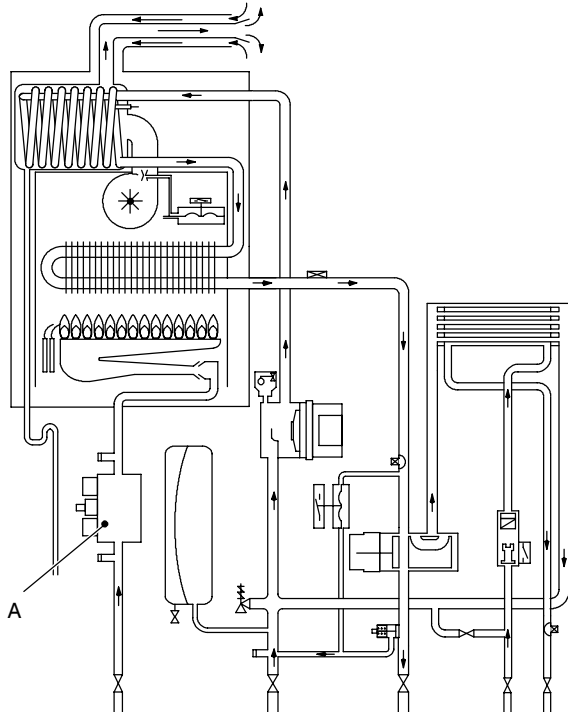

Fig. 53

By means of an electric command given to the on–off operators the passage of the gas through the Modulating gas valve can be opened or closed.

By means of an electric command given to the modulation operator the pressure can be varied and therefore the gas flow rate to the burner (modulation). The modulation operator has mechanical components which allow the adjustment of the minimum and maximum pressure exiting the valve.

11.2 Nomenclature of the parts (Fig. 54)

- 1 Minimum gas pressure adjustment
- 2 Maximum gas pressure adjustment
- 3 Modulation operator's electric connectors
- 4 On–off operators electric connector
- 5 On–off operators
- 6 Gas valve inlet pressure test point
- 7 Gas valve outlet pressure test point
- 8 Modulation operator

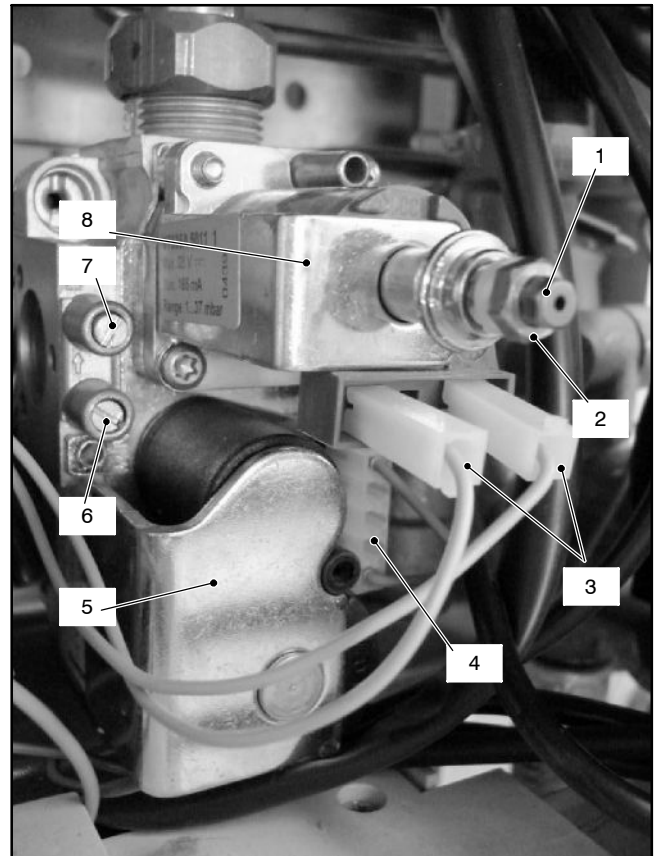

Fig. 54

11.3 Adjustment

Warning: isolate the boiler from the mains electricity supply before removing any covering or component.

- 1 Remove the front panel of the case.
- 2 Open the gas valve inlet pressure test point (6 in Fig. 54) at the valve input, connect a suitable pressure gauge and check the gas pressure of the supply network.
- 3 Remove the gauge and close the pressure test point 6.
- 4 Open the gas valve outlet pressure test point (7 in Fig. 54) and connect the gauge;
- 5 Remove the protection cap B (Fig. 55) from the mechanical pressure adjustment components levering with a flat screwdriver in the slots C.

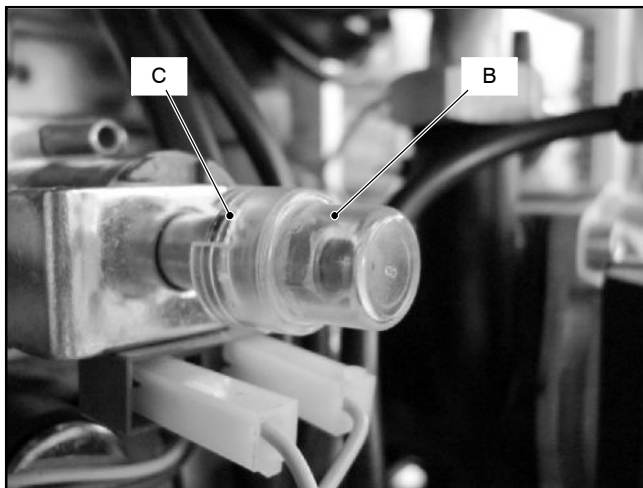

Fig. 55

- 6 Start the boiler at its maximum power. Operate the boiler in d.h.w. mode or ensure that the boiler is not range rated if the test is carried out in c.h. mode.
- 7 Rotate the maximum gas pressure adjustment (2 in Fig. 54) until you obtain the required pressure (by rotating clockwise the pressure increases).
- 8 Turn the boiler off and disconnect one of the two connectors (3 in Fig. 54).
- 9 Start the boiler and rotate the minimum gas pressure adjustment (1 in Fig. 54) until you obtain the required pressure (by rotating clockwise the pressure increases).
- 10 Turn the boiler off and re-connect the wire to the modulating operator.
- 11 Start the boiler and check again the maximum gas pressure setting.
- 12 Turn the boiler off and disconnect the gauge.

Important: after the gas pressure checks and any adjustment operations, all of the test points must be sealed and replace the adjustment protection cap.

11.4 Checks

Warning: isolate the boiler from the mains electricity supply before removing any covering or component.

- ✓ Check the modulation operator coil
 - 1 Remove the front panel of the case.
 - 2 Disconnect the connectors *D* (Fig. 57) from the modulating operator and measure the electrical resistance of the coil. Its electrical resistance value must be approx. $114 \Omega^*$.
- ✓ Check the on-off operators coils
 - 1 Remove the front panel of the case.
 - 2 Disconnect the electrical connector *E* (Fig. 57).

- 3 Measure the electrical resistance between the connector pins of the on-off operators as illustrated in Fig. 56.

On-off operator
approx. $4\ 180 \Omega^*$

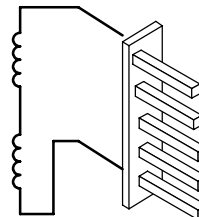

* at ambient temperature.

Fig. 56

11.5 Removal of the gas valve

Warning: isolate the boiler from the mains electricity supply before removing any covering or component.

- 1 Remove the front panel of the case as explained in the section 2.3 of this manual.
- 2 Disconnect the connectors *D* and *E* (Fig. 57).
- 3 Turn off the gas supply and disconnect the gas isolation cock connector from the inlet port of the gas valve.
- 4 Unscrew the connectors *F* and remove the pipe *G*.
- 5 Unscrew the screws *H* and remove the valve.
- 6 Reassemble the valve carrying out the removal operations in reverse order.

After any service operation on the components of the gas circuit check all the connections for gas leaks.

Warning: After cleaning or replacement as detailed above, if it deemed necessary to undertake a combustion analysis, refer to the appropriate chapter *Maintenance* of the installation instructions manual.

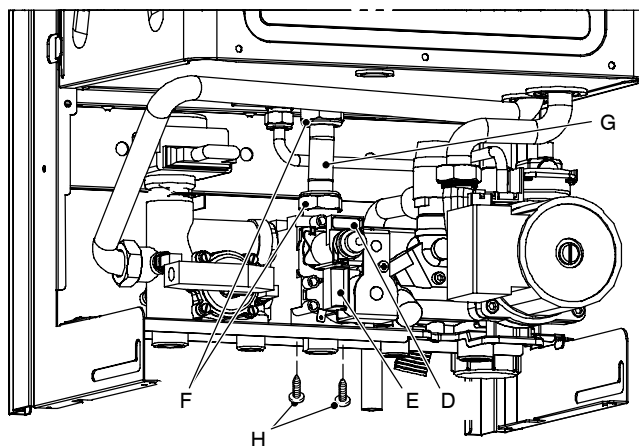

Fig. 57

12 Primary circuit flow switch

12.1 Function

The Primary circuit flow switch (A in Fig. 58) function is to detect water flowrate through the primary hydraulic circuit of the boiler.

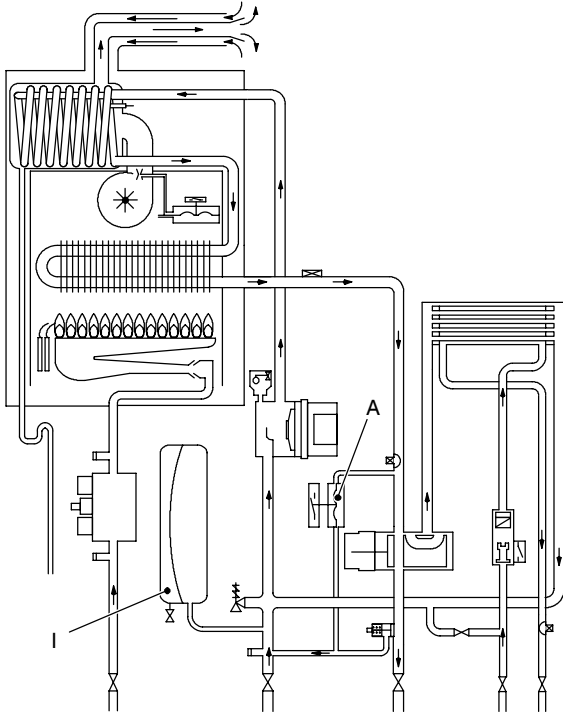

Fig. 58

This hydraulic/membrane operated electrical micro-switch device will control the functioning of the ignition control circuit, providing there is an adequate quantity and flow of water in the primary circuit. Any failure of the pump or obstructions in the primary circuit, whilst in either c.h. or d.h.w. modes, will not allow the device to operate.

This device is connected to the electronic control p.c.b. and if, after the pump operates, it does not activate within 20 seconds the control board will indicate that a fault condition (see section 10.4 of this manual) has occurred.

12.2 Checks

Warning: isolate the boiler from the mains electricity supply before removing any covering or component.

✓ Mechanical function

- 1 Remove the front panel of the case.
- 2 Start and stop the boiler either in d.h.w. or c.h. mode.
- 3 Looking through the switch box verify the position of the shaft B referring to Fig. 59.

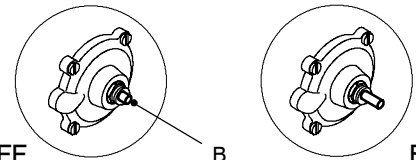

Fig. 59

✓ Electrical check

It is possible to verify the general operation of the switch by measuring the electric resistance between the contacts C. and N.O. of the switch.

- 1 Remove the switch as explained in section 12.3.
- 2 Measure the electrical resistance between the tabs marked C. and N.O. (Fig. 60). The contact must be normally open.
- 3 Operate the switch by hand and verify that the contact is now closed.

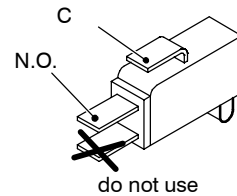

Fig. 60

12.3 Removal

Warning: isolate the boiler from the mains electricity supply before removing any covering or component.

✓ Removal of the switch

- 1 Remove the front panel of the case.
- 2 Remove the fork C (Fig. 61).
- 3 Open the box and disconnect the switch.
- 4 Re-assemble the parts in reverse order of removal. Refer to Fig. 60 for the correct wiring connectors on the switch

✓ Removal of the membrane

- 1 Remove the front and right hand side panels of the case, turn off the flow and return isolation valves and empty the primary circuit.
- 2 Remove the fork C that holds the micro-switch housing D (Fig. 61).

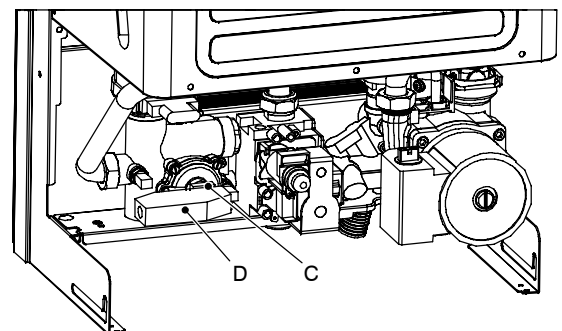

Fig. 61

- 3 Unscrew the four screws E (see Fig. 62) open the hydraulic operator and remove the membrane F.

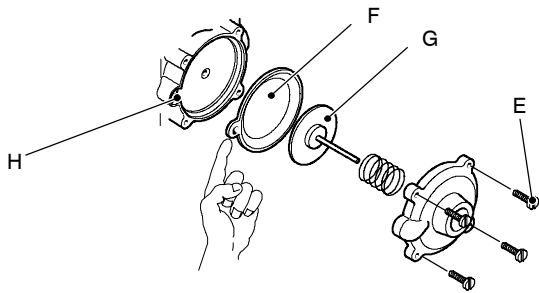

Fig. 62

4 Reassemble the parts in reverse order of removal.

When assembling the membrane, ensure that its concave side faces towards the actuator plate G and the reference indicated aligns with the seat H (see Fig. 62).

13 Expansion vessel and temperature–pressure gauge

13.1 Function

The Expansion vessel (I in Fig. 58) function is to allow for the volume expansion of the c.h. circuit water due to the temperature rise.

13.2 Checks

- 1 Turn off the flow and return isolation valves and empty the primary circuit of the boiler.
- 2 Remove the protective cap J (Fig. 63) from the valve on the top of the expansion vessel and connect a suitable air pressure gauge.

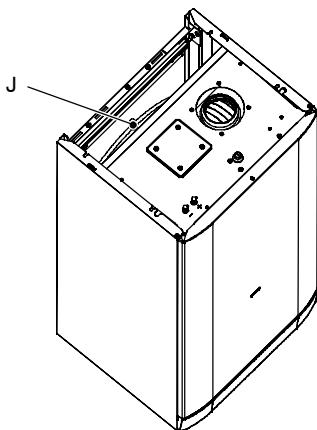

Fig. 63

3 Check the pre-load pressure and refer to the section *Expansion vessel* in the *User manual and installation instructions* for the correct value.

13.3 Removal of the expansion vessel

If there is at least 400 mm clearance above the boiler and the rear exit flue can be easily removed, the expansion vessel can be changed without removing the boiler.

Warning: isolate the boiler from the mains electricity supply before removing any covering or component.

- 1 Remove the front and left hand side panels of the case, turn off the flow and return isolation valves and empty the primary circuit.
- 2 Completely unscrew the connection K, the lock-nut L (Fig. 64) and remove the expansion vessel from the top of the boiler.

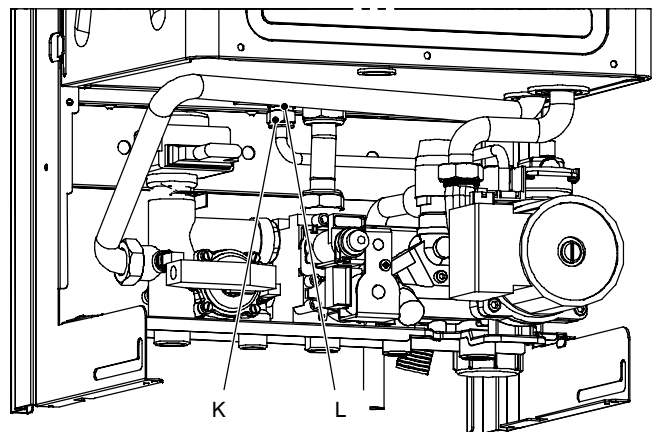

Fig. 64

3 Re-assemble the parts in reverse order of removal.

13.4 Removal of the temperature–pressure gauge

- 1 Remove the front and right hand side panels of the case, turn off the flow and return isolation valves and empty the primary circuit.
- 2 Remove the fork M and the probe holder spring N (Fig. 65).
- 3 Squeeze the tabs O to release the temperature–pressure gauge P and remove it.
- 4 Re-assemble the parts in reverse order of removal.

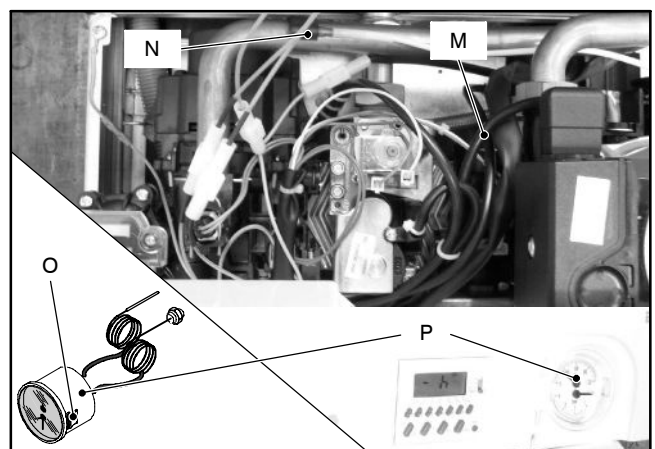

Fig. 65

14 D.h.w. flow switch, filter

14.1 Function

The d.h.w. flow switch *A* in Fig. 66 is a device that generates an electrical signal when hot water is drawn.

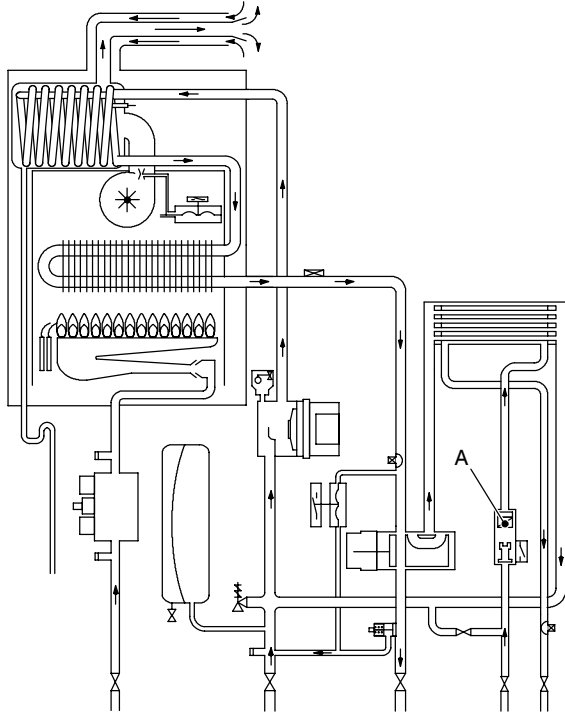

Fig. 66

When the flow rate through the d.h.w. circuit reaches about 2,5 litres/min', the float 5 (Fig. 66) is dragged upwards and the magnet in it, getting closer to the sensor 8, closes the electric contact.

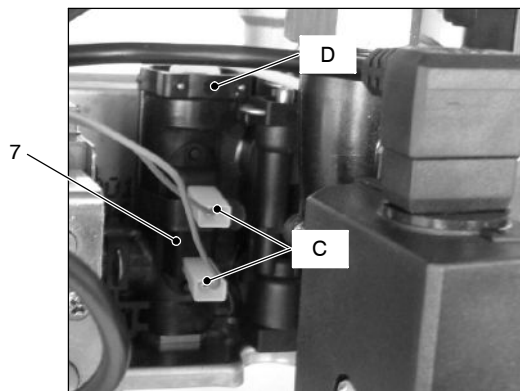

Fig. 67

14.2 Description and location of parts (Fig. 68)

- 1 Flow switch plug
- 2 O-ring
- 3 Flow limiter (optional for M96.28SM/..., M96.32SM/...)
- 4 Body
- 5 Float
- 6 Filter
- 7 Sensor holder spring

8 Sensor

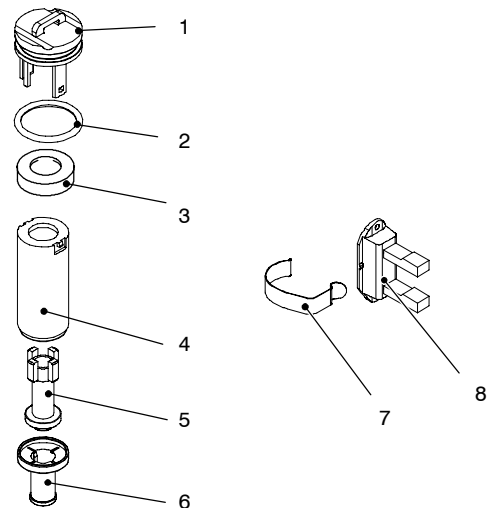

Fig. 68

14.3 Checks

Warning: isolate the boiler from the mains electricity supply before removing any covering or component.

✓ Sensor operation

- 1 Remove the front panel of the case.
- 2 Disconnect the connectors *B* and measure the electrical resistance between the leads of the sensor. Without water being drawn, the contact must be open. By opening a hot water tap the contact must be close (electrical resistance zero Ω).

14.4 Removal of the sensor

Warning: isolate the boiler from the mains electricity supply before removing any covering or component.

- 1 Remove the front panel of the case.
- 2 Disconnect the connectors *C* and remove the sensor holder spring 7 (Fig. 67).
- 3 Remove the sensor.

14.5 Removal of the flow switch group and d.h.w. circuit filter

Warning: isolate the boiler from the mains electricity supply before removing any covering or component.

- 1 Remove the front panel of the case and empty the d.h.w. circuit.
- 2 Remove the fork *D* and pull up the flow switch plug 1 with the help of a screwdriver.
- 3 To remove the filter from the flow switch group separate the filter 6 from the body 4 (Fig. 68) by levering it.
- 4 Reassemble the parts following the removing sequence in reverse order.

14.6 Flow limiter

The M96.24SM/... model is factory fitted with a 10 litre/min. flow limiter.

If on the M96.28SM/... and M96.32SM/... model the flow rate of the d.h.w. circuit is too high, it is possible to limit it by installing a flow limiter. The following sizes are available:

Nominal flow rate (litres/min)	Colour
10	Black
12	Grey
14	Green

To install the flow limiter:

- 1 Remove the flow switch group as explained in the section 14.5.
- 2 Remove the flow switch plung 1 from the body 4 by gently levering the hooks.
- 3 Insert the flow limiter 3 as shown in Fig. 68
- 4 Reassemble the group following the above sequence in reverse order.

15 Temperature probe

15.1 Function

The Temperature probe has the function of converting the temperature of the water in the hydraulic circuit where it is installed into an electrical signal (resistance). The relation between temperature and electrical resistance is stated in Fig. 69.

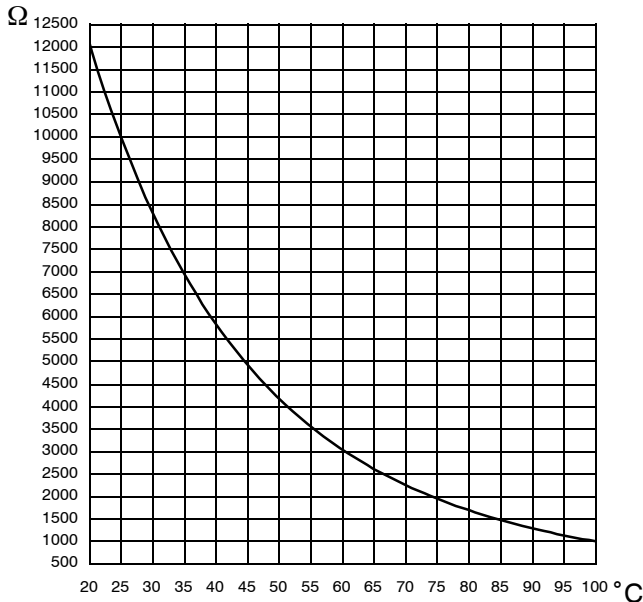

Fig. 69

On the boiler there are two Temperature probes. One on the output of the primary heat exchanger (c.h. Temperature probe) A in Fig. 70 and Fig. 71; one on the output of the d.h.w. heat exchanger (d.h.w. Temperature probe) B in Fig. 70 and Fig. 71.

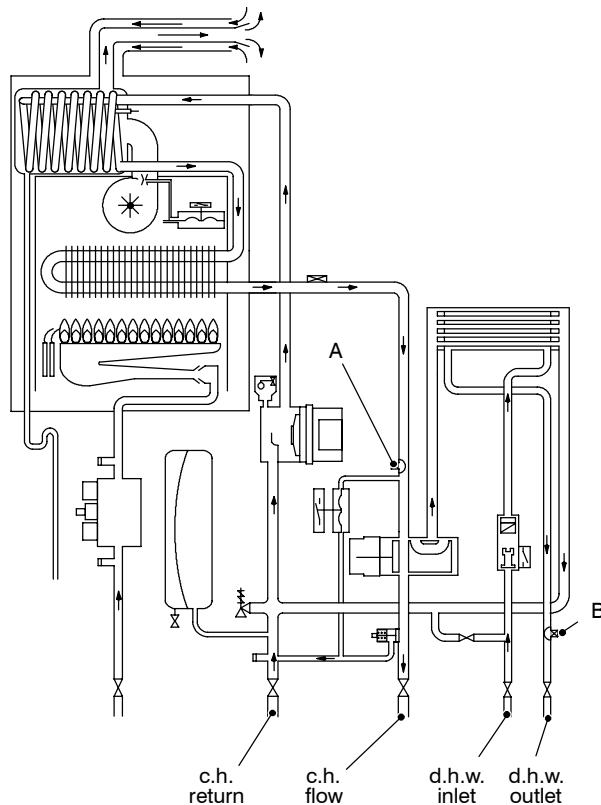

Fig. 70

15.2 Checks

✓ Temperature–resistance relationship

⚡ **Warning: isolate the boiler from the mains electricity supply before removing any covering or component.**

Disconnect the cable from the Temperature probe.

Measure the temperature of the brass group where the Temperature probe is located and check the electrical resistance according to the graph in Fig. 69.

15.3 Removal

⚡ **Warning: isolate the boiler from the mains electricity supply before removing any covering or component.**

- 1 To remove the Temperature probes remove the front panel of the case.
- 2 To remove the c.h. Temperature probe empty the primary circuit of the boiler. To remove the d.h.w. Temperature probe empty the d.h.w. circuit of the boiler.
- 3 Remove the electric connector of the Temperature probe and unscrew it.
- 4 Reassemble the Temperature probe carrying out the removal operations in reverse order.

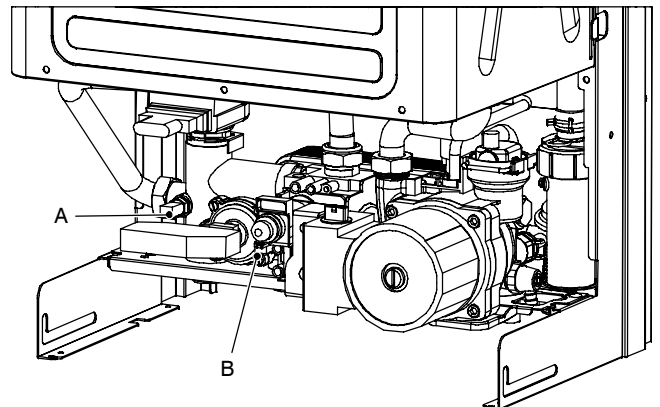

Fig. 71

16 By-pass valve

16.1 Function

The By-pass valve A in Fig. 72 is located between the c.h. water flow and return and its function is that of guaranteeing a minimum flow across the primary heat exchanger if the circulation across the c.h. system is completely closed.

The By-pass valve is fitted on the rear side of the diverter group.

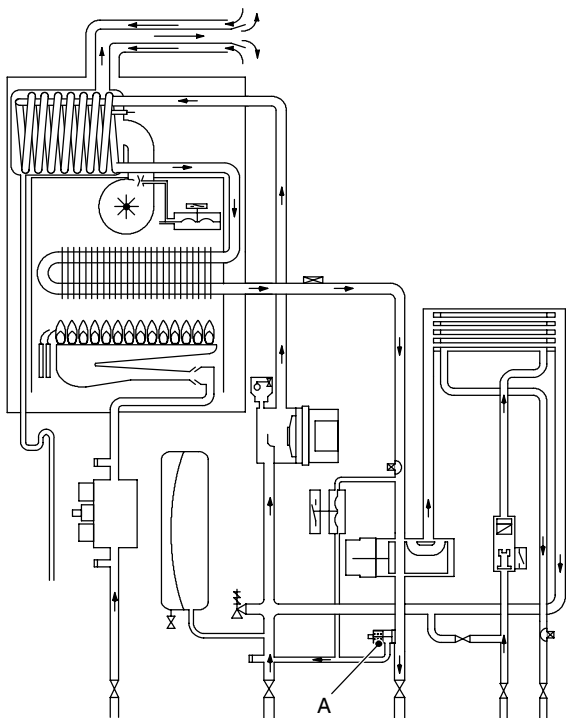

Fig. 72

16.2 Removal

Warning: isolate the boiler from the mains electricity supply before removing any covering or component.

- 1 Remove all the case panels.
- 2 Empty the primary circuit of the boiler.
- 3 Remove the diverter group as described in the section 9.4 of this manual.
- 4 Unscrew the connector B and remove the by-pass valve C (Fig. 73).

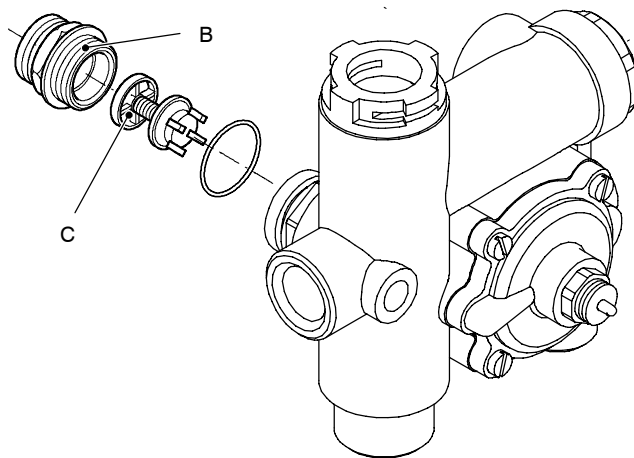

Fig. 73

- 5 Reassemble the by-pass valve as illustrated in Fig. 73 reversing the order of removal.

17 Fan, venturi device and Air pressure switch

17.1 Function

The function of the Fan A (Fig. 74 and Fig. 75) is to force the products of combustion through the condensing heat exchanger to the outside air via the flue system.

The Fan is supplied by the full sequence ignition device at the beginning of the ignition cycle.

Its correct functioning is controlled by means of a system incorporating a built in venturi device (B in Fig. 80) and an Air pressure switch C (Fig. 74 and Fig. 75) .

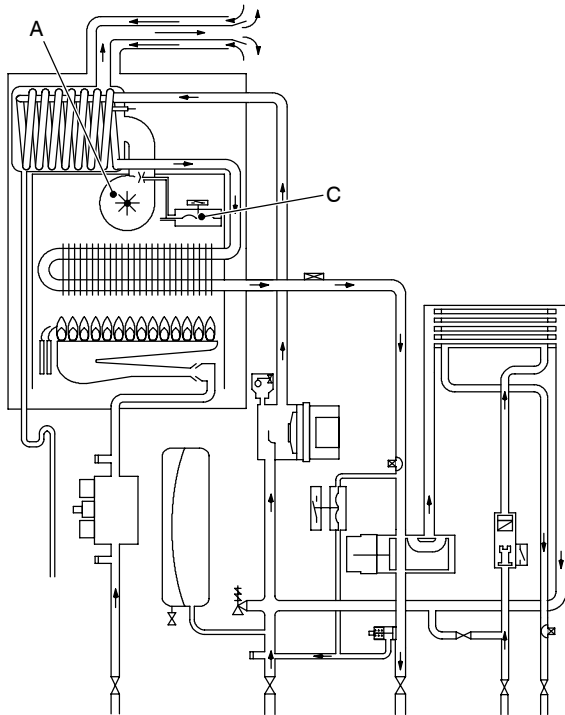

Fig. 74

17.2 Checks

✓ Check of the fan

⚡ **Warning: isolate the boiler from the mains electricity supply before removing any covering or component.**

- 1 Remove all the case panels and the sealed chamber lid.
- 2 Disconnect the connectors D (Fig. 75) and measure the electrical resistance of the motor that has to be about:
 43Ω – M96.24SM/...
 25Ω – M96.28SM/... M96.28SR/... M96.32SM/...
 (at ambient temperature).

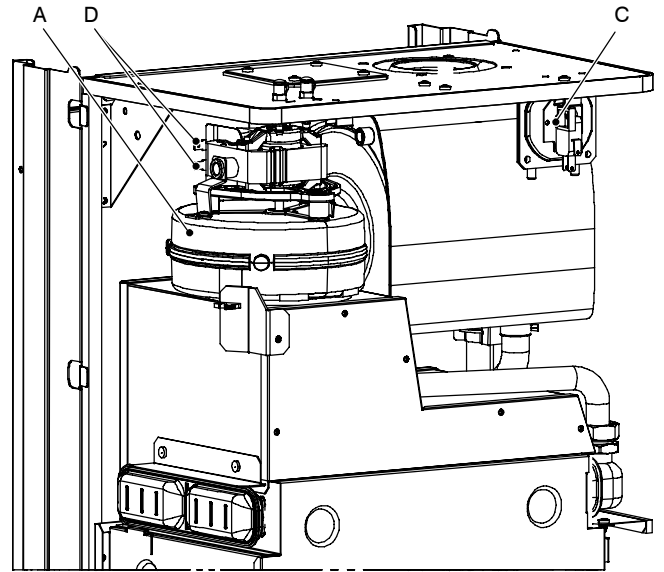

Fig. 75

✓ Check of the Air pressure switch operation

⚡ **Warning: isolate the boiler from the mains electricity supply before removing any covering or component.**

- 1 Remove all the case panels and the sealed chamber lid.
- 2 Disconnect the wires and check the electrical resistance between the connections of the Air pressure switch.
 Refer to the Fig. 76 in accordance with the type of air pressure switch used.

Between COM or 3 and N.O. or 2 the contact must be open.

Between COM or 3 and N.C. or 1 the contact must be closed (electrical resistance zero).

- 3 Connect the grey wire (COM or 3)
- 4 Run the boiler (the Fan must run) and check the the electric resistance between COM or 3 and N.O. or 2. Between COM or 3 and N.O. or "2 the contact must be closed (electrical resistance zero).

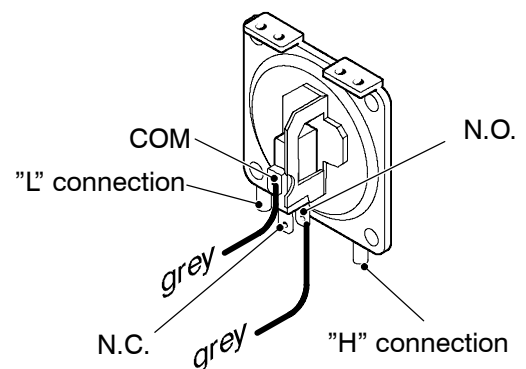

Fig. 76

✓ Check of the venturi device

This test must be carried out with the sealed chamber closed

- 1 Remove the caps of the pressure test points located on the top of the boiler and connect a differential pressure gauge (Fig. 77).
- 2 Switch on the boiler.

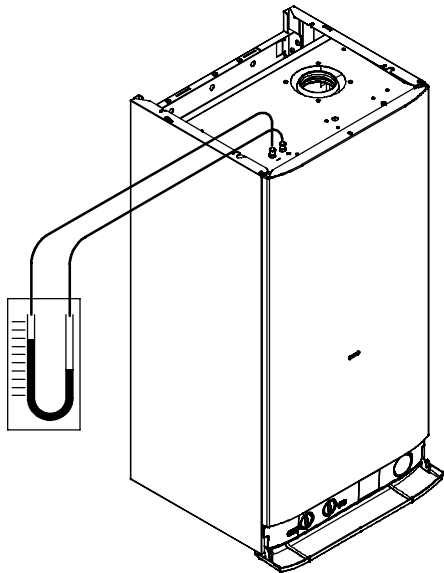

Fig. 77

- 3 Compare the value on the gauge with the following minimum values:
 80 Pa (0,8 mbar) – M96.24SM/...
 110 Pa (1,1 mbar) – M96.28SM/..., M96.28SR/...
 and M96.32SM/...

17.3 Removal of the Fan

Warning: isolate the boiler from the mains electricity supply before removing any covering or component.

- 1 Remove all the case panels, the sealed chamber lid and the combustion chamber lid.
- 2 Disconnect the connectors *D* and the earth connection *E* (Fig. 75).
- 3 Disconnect the pipe which connect the venturi device to the Air pressure switch.
- 4 Unscrew the screw *F* and remove the bracket *G* (Fig. 78).

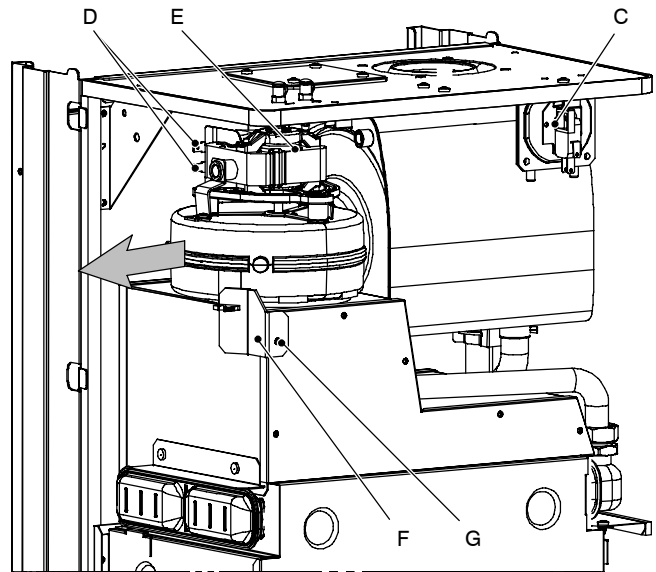

Fig. 78

- 5 Remove the Fan by sliding it towards left (see the arrow in Fig. 78).
- 6 Assemble the fan carrying out the removal operations in reverse sequence.

Warning: Re-assembling the fan ensure that the hooks around the inlet port of the fan hung correctly on the flue hood.

Warning: to correctly connect the venturi device to the Air pressure switch, refer to Fig. 79.

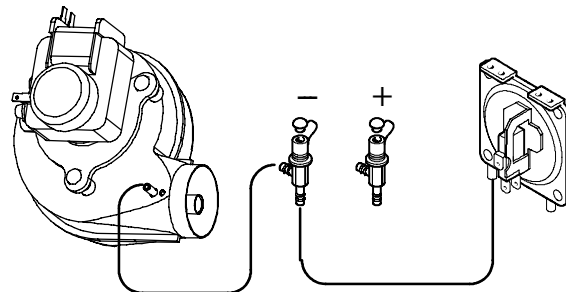

Fig. 79

Warning: After cleaning or replacement as detailed above, if it deemed necessary to undertake a combustion analysis, refer to the appropriate chapter *Maintenance* of the installation instructions manual.

17.4 Inspection and removal of the venturi device

Warning: isolate the boiler from the mains electricity supply before removing any covering or component.

- 1 Remove the fan (section 17.3).
- 2 Remove the venturi device by unscrewing the screw *H*.

- 3 Inspect the venturi device *B* and the connection pipe *I*. Ensure they are clean.
- 4 Re-assemble the parts in reverse order of removal.



Warning: After cleaning or replacement as detailed above, if it deemed necessary to undertake a combustion analysis, refer to the appropriate chapter *Maintenance* of the installation instructions manual.

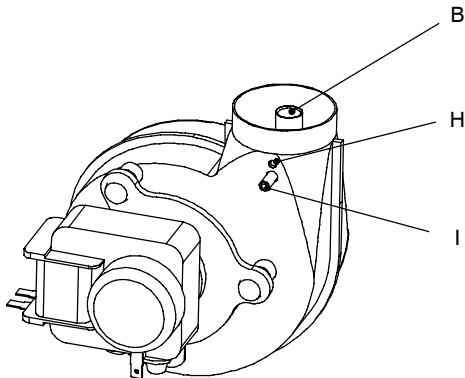

Fig. 80

17.5 Removal of the Air pressure switch



Warning: isolate the boiler from the mains electricity supply before removing any covering or component.

- 1 Remove all the case panels and the sealed chamber lid.
- 2 Disconnect the wires from the Air pressure switch.
- 3 Remove the pipe from the Air pressure switch.
- 4 Unscrew the screws which hold the Air pressure switch to the frame.
- 5 Assemble the Air pressure switch carrying out the removal operations in reverse sequence.

Warning: to correctly connect the Air pressure switch, refer to Fig. 79 and Fig. 76a or Fig. 76b for the correct wiring.



Warning: After cleaning or replacement as detailed above, if it deemed necessary to undertake a combustion analysis, refer to the appropriate chapter *Maintenance* of the installation instructions manual.

18 Ignition and detection electrodes

18.1 Function

Three electrodes are fitted on the burner. Two of them are the ignition electrodes and are fitted near the front part of the burner. The ignition sparks take place between their metallic edges over the central ramp of the burner during the ignition sequence.

The third electrode is the detection electrode and it detects the presence of the flame.

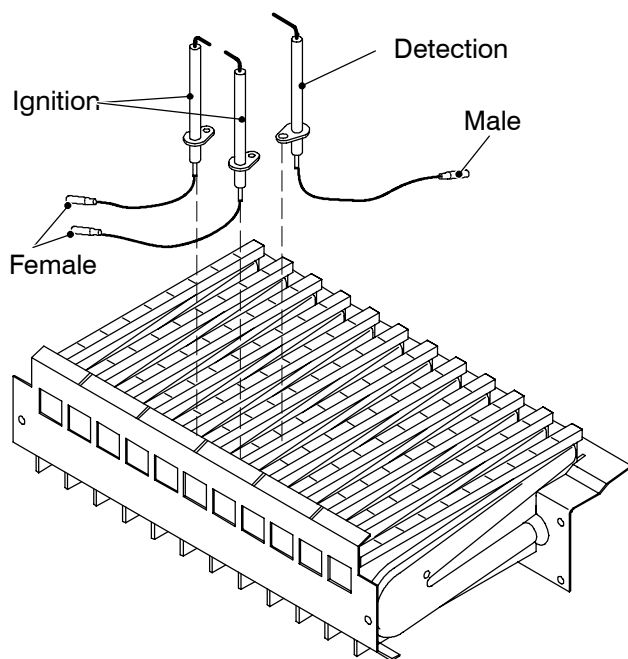

Fig. 81

18.2 Checks

✓ Check the position of the electrode edges

⚡ **Warning: isolate the boiler from the mains electricity supply before removing any covering or component.**

- 1 Remove all the case panels, the sealed chamber lid and the combustion chamber lid.
- 2 Check for the correct distance between the metallic edges of the ignition electrodes (see Fig. 82).

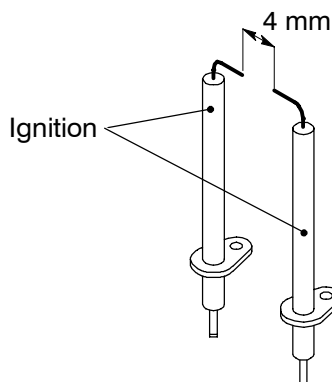

Fig. 82

- 3 Check the integrity of the detection electrode and ensure that its metallic edge is correctly placed over the ramp of the burner.

✓ Check the connection wires.

⚡ **Warning: isolate the boiler from the mains electricity supply before removing any covering or component.**

- 1 Remove all the case panels, the sealed chamber lid and the combustion chamber lid.
- 2 Check for the integrity of the insulation of wires which connect the electrodes to the ignition device.

18.3 Removal

⚡ **Warning: isolate the boiler from the mains electricity supply before removing any covering or component.**

- 1 Remove all the case panels, the sealed chamber lid and the combustion chamber lid.
- 2 Disconnect the electrode wires from the full sequence ignition device.
- 3 Remove the plate C (see Fig. 85 on page 37).
- 4 Remove the burner by unscrewing the four screws placed at the right and left sides of the burner.
- 5 Unscrew the screws A (Fig. 83) which hold the electrodes to the burner.

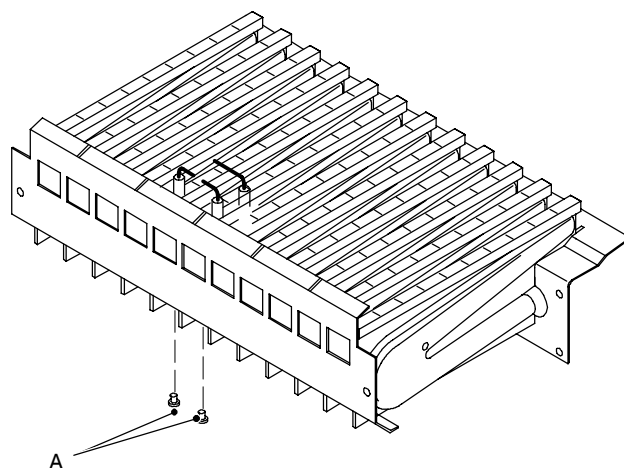

Fig. 83

- 6 Extract the electrodes from the burner.
- 7 Assemble the electrodes carrying out the removal operation in reverse order. Refer to Fig. 81 in order to recognise the electrodes and to correctly connect the wiring.

Note: the metallic edge of the detection electrode is longer than the one of the ignition electrodes.

⚠ **Warning: After cleaning or replacement as detailed above, if it deemed necessary to undertake a combustion analysis, refer to the appropriate chapter *Maintenance* of the installation instructions manual.**

19 Safety thermostat

19.1 Function

The safety thermostat *A* in Fig. 84 and Fig. 85 is a device that senses the temperature of the primary circuit water which flows in the outlet pipe of the primary heat exchanger.

If the temperature control system of the boiler fails and the temperature of the primary circuit reaches a dangerous temperature, the safety thermostat opens the electric circuit that supplies the on-off operators of the gas valve.

Consequently, the full sequence ignition device attempts to light the burner and, at the end, locks the boiler and lights the lock-out signal lamp.

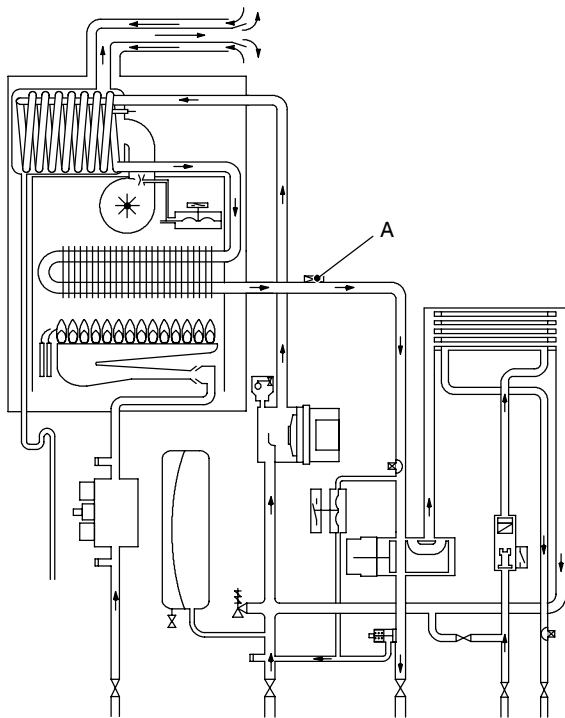

Fig. 84

19.2 Checks

✓ Overheat temperature value

- 1 Set the temperature control knobs to their max. position and run the boiler in d.h.w. and c.h.
- 2 Allow the boiler to reach its maximum operating temperature (monitor the temperature gauge on the instrument panel). The boiler should maintain a temperature below that of the safety thermostat and no overheat intervention should occur.

⚡ **Warning: isolate the boiler from the mains electricity supply before removing any covering or component.**

✓ Electrical function

- 1 Remove all the case panels and the lid of the sealed chamber.

- 2 Remove the screws *B* and the plate *C* (Fig. 85).
- 3 Disconnect the safety thermostat and check its electrical function. Normally (no intervention) the contact must be closed (electrical resistance zero Ω).

19.3 Removal

⚡ **Warning: isolate the boiler from the mains electricity supply before removing any covering or component.**

- 1 Remove all the case panels and the lid of the sealed chamber.
- 2 Remove the screw *B* and the plate *C* (Fig. 85).

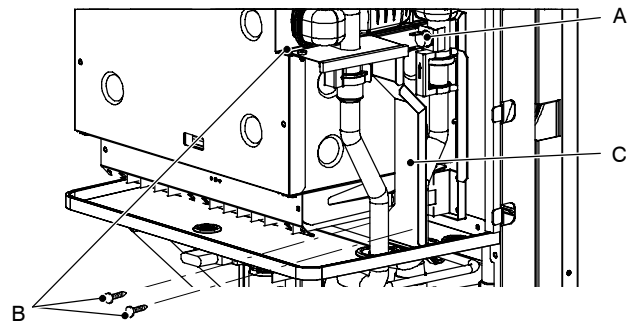

Fig. 85

- 3 Disconnect the wiring *D* (detail in Fig. 86).
- 4 Remove the spring *E* which holds the overheat thermostat on the pipe of the primary heat exchanger and remove it.

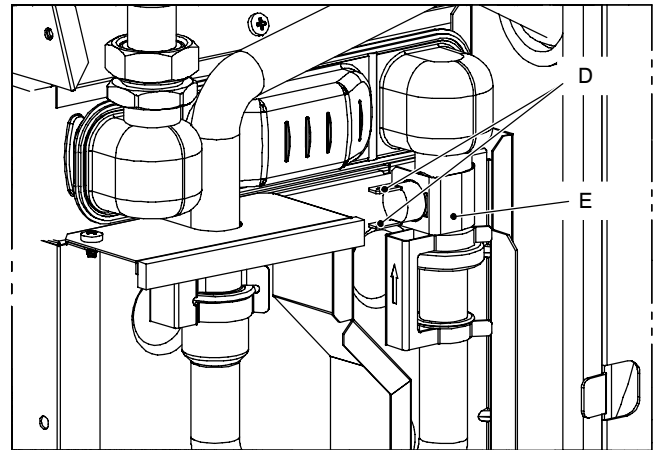

Fig. 86

- 5 Reassemble the overheat thermostat carrying out the operations in reverse order.
- 6 Apply an adequate quantity of heat conducting compound between the pipe and the thermostat.

⚠ **Warning: After cleaning or replacement as detailed above, if it deemed necessary to undertake a combustion analysis, refer to the appropriate chapter *Maintenance of the installation instructions manual.***

20 Flue temperature probe NTC

20.1 Function

The Flue temperature probe NTC A in Fig. 87 and Fig. 88 senses the temperature of the combustion products that flow through the condensing heat exchanger.

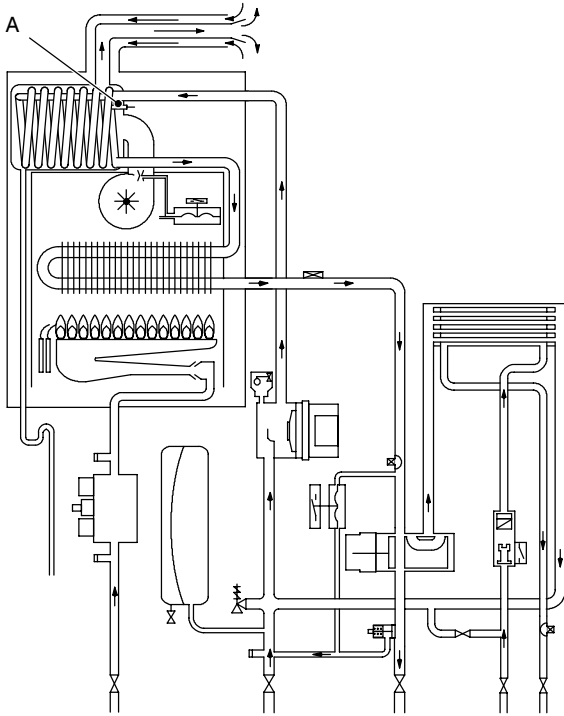

Fig. 87

If the temperature of the combustion products circuit reaches the limit temperature, the Flue temperature probe NTC reduces the gas flow rate to the burner. The temperature of the combustion products should decrease to a safe value temperature.

In the case that the temperature of the combustion products reaches a potentially dangerous value, it stops the boiler operation. It is therefore allowed the use of plastic materials for the flue outlet pipes and bends.

The use of kits different from the original isn't however allowed, since the flue pipes are integral parts of the boiler.

If not, the electronic control p.c.b. attempts to light the burner and, at the end, locks the boiler and lights the lock-out signal lamp.

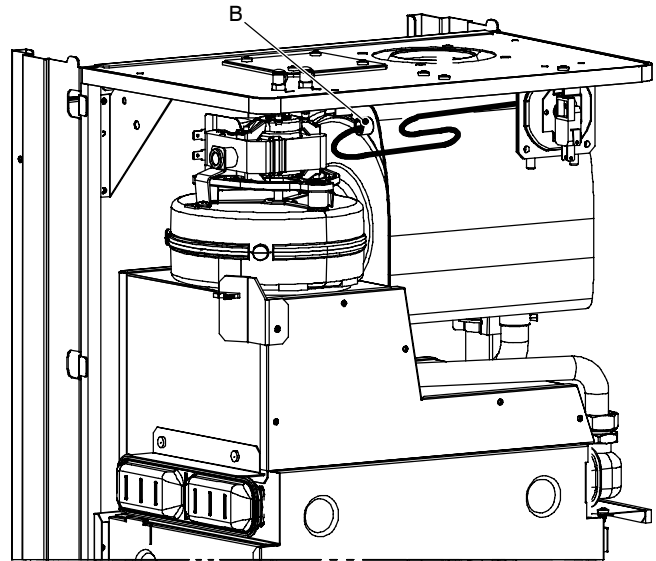

Fig. 88

20.2 Checks

- ✓ Overheat temperature value
- 1 Set the temperature control knobs to their max. position and run the boiler in d.h.w. and c.h.
- 2 Allow the boiler to reach its maximum operating temperature (monitor the temperature gauge on the instrument panel). The boiler should maintain a temperature below that of the Flue temperature probe NTC and no overheat intervention should occur.

20.3 Removal

- ⚡ **Warning: isolate the boiler from the mains electricity supply before removing any covering or component.**
- 1 Remove all the case panels and the sealed chamber lid.
- 2 Disconnect the wires from the Flue temperature probe NTC.
- 3 Unscrew and remove the thermostat probe B (Fig. 88) from the condensing heat exchanger.
- 4 Assemble the Flue temperature probe NTC carrying out the removal operations in reverse sequence.

21 Condensate trap

21.1 Function

The condensate trap *A* in Fig. 89 and Fig. 91 allows the discharge of the condensate via the condensate drain pipe avoiding in the mean time the escape of combustion products.

A plastic ball closes the trap outlet in case that the trap is empty.

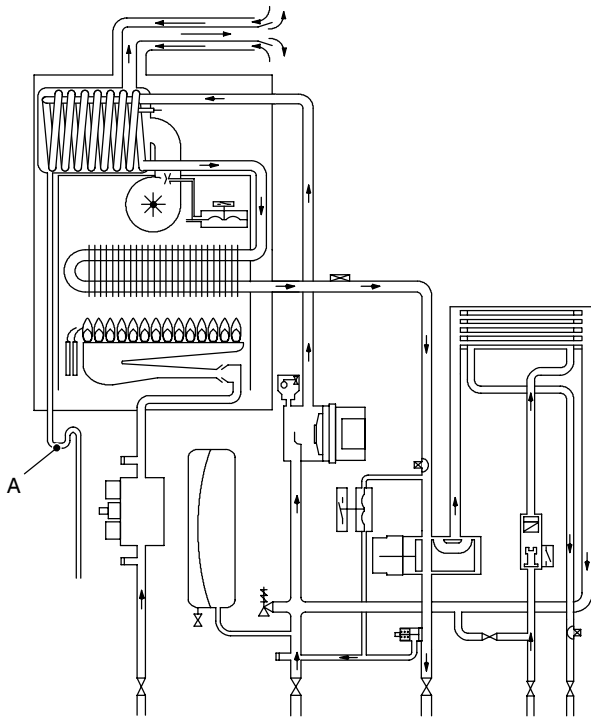

Fig. 89

The condensate trap is provided with two electrodes. The electrode *B* is connected to the ground circuit; the electrode *C* is connected to the flame detecting electrode (Fig. 90).

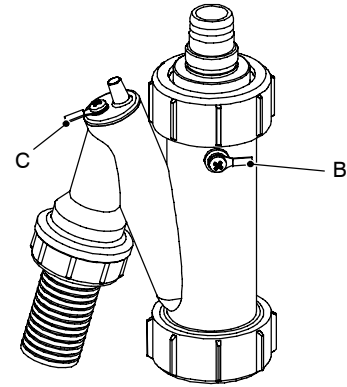

Fig. 90

If the drain pipe is plugged or in any case in which the condensate isn't correctly evacuated, the condensate level in the trap rises putting in contact the electrodes thus causing the boiler lock-out.

21.2 Removal

Warning: isolate the boiler from the mains electricity supply before removing any covering or component.

- 5 Remove the front and right case panels.
- 6 Disconnect the trap from the draining pipe.
- 7 Using pliers, remove the spring *D* moving it upwards.
- 8 Remove the spring *E* and lower the trap.
- 9 Disconnect the wirings from the trap.
- 10 Reassemble carrying out the removal operations in reverse order.

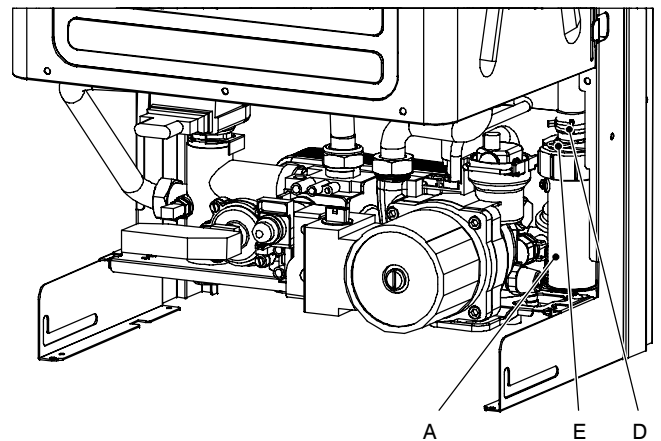
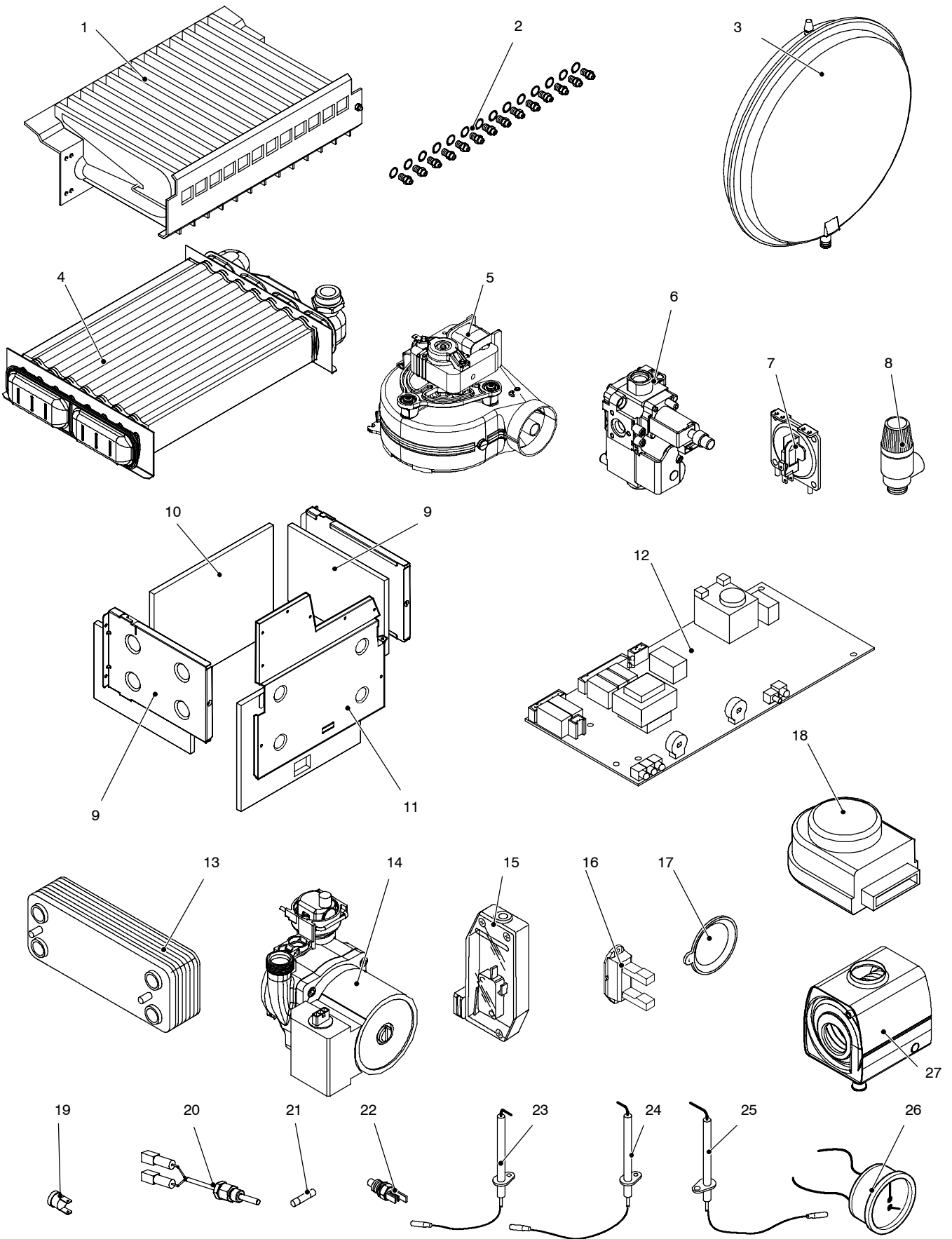

Fig. 91

22 Short spare parts list

Key	G.C. part no.	Description	Q.ty	Manufacturer part no.	Manufacturer's reference
1	173–148	Burner (mod. M96.24SM/...)	1	KI1004 102	Polidoro
	173–149	Burner (mod. M96.28SM/... M96.28SR/... M96.32SM/...)	1	KI1004 147	
2	169–069	Injectors for natural gas (mod. M96.24SM/... ,)	12	KI1064 505	Polidoro
		Injectors for natural gas (mod. M96.28SM/... M96.28SR/... M96.32SM/...)	14		
	E01–156	Injectors for LPG (mod. M96.24SM/... , M96.24SR/...)	12	BI1003 509	
		Injectors for LPG (mod. M96.28SM/... M96.28SR/...)	14		
		Injectors for LPG (mod. M96.32SM/...)	14	BI1243 500	
3	E83–121	Expansion vessel	1	BI1172 103	CIMM 6 litres
4	H20–984	Main heat exchanger (mod. M96.24SM/..., M96.24SR/...)	1	BI1262 101	
	H20–985	Main heat exchanger (mod. M96.28SM/... M96.28SR/...)	1	BI1262 102	
		Main heat exchanger (mod. M96.32SM/...)	1	BI1262 130	
5	H21–048	Fan (mod. M96.24SM/..., M96.24SR/...)	1	BI1406 100	
	H21–049	Fan (mod. M96.28SM/..., M96.28SR/..., M96.32SM/...)	1	BI1406 101	
6		Gas valve	1	BI1243 100	Honeywell
7	169 127	Air pressure switch 0,88–0,74 mbar (mod. M96.24SM/... M96.32SM/... , M96.24SR/...)	1	KI1267 103	Yamatake–Honeywell C6065 SIT 380 (alternative)
	H08–605	Air pressure switch 1,38–1,25 mbar (mod. M96.28SM/..., M96.28SR/...)	1	BI1376 104	Yamatake–Honeywell C6065 SIT 380 (alternative)
8		Safety valve	1	BI1181 100	Watts Orkly (alternative)
9	E83–178	Combustion chamber side panels	2	BI1326 100	
10	E83–180	Combustion chamber rear panel (mod. M96.24SM/..., M96.24SR/...)	1	BI1326 107	
	E83–181	Combustion chamber rear panel (mod. M96.28SM/... M96.28SR/..., M96.32SM/...)	1	BI1326 108	
11		Combustion chamber front panel (mod. M96.24SM/..., M96.24SR/...)	1	BI1406 118	
		Combustion chamber front panel (mod. M96.28SM/... M96.28SR/..., M96.32SM/...)	1	BI1406 119	
12		Electronic regulation p.c.b.	1	BI1715 105	Bertelli & Partners
13	E01–204	D.h.w. heat exchanger (M96.24SM/..., M96.24SR/...)	1	BI1001 101	
	E01–205	D.h.w. heat exchanger (M96.28SM/..., M96.32SM/...)	1	BI1001 102	
14		Pump	1	BI1911 103	
15	E00–684	Primary circuit flow switch	1	BI1011 505	
16		D.h.w. flow switch	1	KI1042 107	
17	E00–688	Main. flow switch membrane	1	BI1011 103	
18	E83–086	Three way diverter valve (electric actuator)	1	BI1101 102	Elbi
19	E83–101	Overheat thermostat	1	BI1172 105	ELTH – type 261
20		Flue temperature probe NTC	1	BI1342 100	
21		Fuse 3,15 AF	2	BI1295 108	
22	164–026	Temperature probe (main or d.h.w. circuit)	1	BI1001 117	
23	E83–127	Ignition electrode (left)	1	BI1123 101	
24	E83–126	Ignition electrode (right)	1	BI1123 103	
25	E83–122	Detection electrode	1	BI1123 102	

26	E83-145	Temperature – pressure gauge	1	BI1475 108	IMIT
27	H07-112	Recuperator	1	BI1262 122	





17962.1165.3 2807 44A4 UK

Biasi UK Ltd
Newman Park, Western Way
Wednesbury, WS10 7BJ
Sales Tel No: 0121 506 1340
Sales Fax No: 0121 506 1360
Service Tel No: 0121 506 1350
Service Fax No: 0121 506 1370
www.biasi.co.uk