

# Instructions for Use Installation and Servicing

To be left with the user

## Micron

### 100FF 120FF

G.C. No. 41-047-52

G.C. No. 41-047-23

### Fanned Flue Boiler



BS 6332  
BS 5258

This is a Cat I<sub>2H</sub> Appliance

Reference in these instructions to British Standards and Statutory Regulations/Requirements apply only to the United Kingdom.

For Ireland the current edition of I.S.813 "Domestic Gas Installations" must be used.

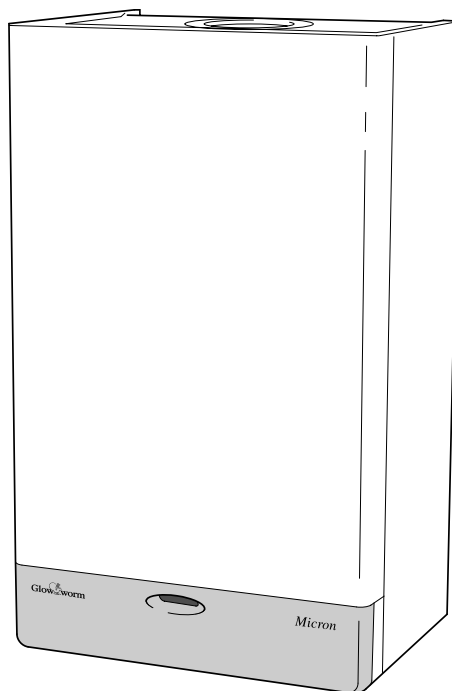

4272

*The instructions consist of three parts, User, Installation and Servicing Instructions.*

*The instructions are an integral part of the appliance and must, to comply with the current issue of the Gas Safety (Installation and Use) Regulations, be handed to the user on completion of the installation.*

## Guarantee Registration

Thank you for installing a new Glow-worm appliance in your home.

Glow-worm appliances' are manufactured to the very highest standard so we are pleased to offer our customers' a Comprehensive First Year Guarantee.

We recommend you complete and return your Guarantee Registration Card as soon as possible.

If this card is missing you can obtain a copy or record your registration by telephoning Glow-worm's own service organisation on 01773 828100.

Our Guarantee gives you peace of mind plus valuable protection against breakdown by covering the cost of:

- All replacement parts**
- All labour charges**
- All call-out charges**

REGISTER YOUR GLOW-WORM APPLIANCE  
FOR 1ST YEAR GUARANTEE PROTECTION

## CALL 0800 073 2142

## Important Information

### Testing and Certification

This boiler is tested and certificated for safety and performance. It is therefore important that no alteration is made to the boiler, without permission, in writing, from Glow-worm.

Any alteration not approved by Glow-worm, could invalidate the certification, boiler warranty and may also infringe the current issue of the Statutory Requirements, see Section 1.4.

### CE Mark

This boiler meets the requirements of Statutory Instrument No. 3083 The boiler (Efficiency) Regulations, and therefore is deemed to meet the requirements of Directive 92/42/EEC on the efficiency requirements for new hot water boilers fired with liquid or gaseous fuels.

Type test for purposes of Regulation 5 certified by: Notified body 0086.

Product/production certified by: Notified body 0086.

The CE mark on this appliance shows compliance with:

1. Directive 90/396/EEC on the approximation of the laws of the Member States relating to appliances burning gaseous fuels.
2. Directive 73/23/EEC on the harmonization of the Laws of the Member States relating to the electrical equipment designed for use within certain voltage limits.
3. Directive 89/336/EEC on the approximation of the Laws of the Member States relating to electromagnetic compatibility.

### INFORMATION FOR THE INSTALLER AND SERVICE ENGINEER.

Under Section 6 of The Health and Safety at Work Act 1974, we are required to provide information on substances hazardous to health.

#### Insulation Pads, Glass yarn.

These can cause irritation to skin, eyes and the respiratory tract. If you have a history of skin complaint you may be susceptible to irritation. High dust levels are usual only if the material is broken. Normal handling should not cause discomfort, but follow normal good hygiene and wash your hands before eating, drinking or going to the lavatory. If you do suffer irritation of the eyes or severe irritation to the skin seek medical attention.

### SPARE PARTS

**REMEMBER:** When replacing a part on this appliance, use only spare parts that you can be assured conform to the safety and performance specification that we require. Do not use reconditioned or copy parts that have not been clearly authorised by Glow-worm.

CONTENTS	DESCRIPTION	SECTION	PAGE No.
<b>INSTRUCTIONS FOR USE</b>	Introduction		3
	Lighting the Boiler		4
<b>INSTALLATION INSTRUCTIONS</b>	General Data	1	5
	Flue Terminal	2	9
	Water Systems	3	10
	Flue and Appliance Preparation	4	12
	Boiler Installation	5	14
	Flue Fixing	6	16
	Electrical Connectors	7	17
	Commissioning	8	18
	Instructions to the User	9	22
<b>SERVICING INSTRUCTIONS</b>	Servicing	10	22
	Fault Finding	11	24
	Replacement of Parts	12	28
	Spare Parts	13	32

# Instructions for Use

## Introduction

**WARNING:** It is important that the case (not the controls tray) is not disturbed or removed other than for servicing by a **competent person**.

Please read these instructions and follow them carefully for the safe and economical use of your boiler.

The Micron FF series are fanned flue boilers designed to provide central heating and indirect domestic hot water.

The boiler is fully automatic in operation having only one user control, the control thermostat.

## Gas Leak or Fault

Turn off the gas emergency control valve immediately. Eliminate all sources of ignition, i.e. smoking, blowlamps, hot air guns etc. Do not operate electrical lights or switches either on or off. Open all doors and windows, ventilate the area.

## Electrical Supply Failure

Failure of the electrical supply will cause the burner to go out. Should this occur, operation of the appliance will normally resume after the electrical supply is restored.

If the boiler does not relight after an electrical supply failure the overheat safety cutoff device may need resetting, remove the controls cover and press the reset button, refer to diagram 8.1.

## Overheat Safety Cutoff

If the overheat safety cutoff device operates on any other occasion than an electrical supply failure, press the reset button as in "Electrical Supply Failure". If the overheat operates again, turn the appliance off and contact your installation/servicing company.

## Maintenance

To ensure the continued efficient and safe operation of the boiler it is recommended that it is checked and serviced as necessary at regular intervals. The frequency of servicing will depend upon the particular installation conditions and usage, but in general once a year should be enough.

If this appliance is installed in a rented property in the UK there is a duty or care imposed on the owner of the property by the current issue of The Gas Safety (Installation and Use) Regulations, Section 35.

It is the law that any servicing is carried out by a **competent person**.

To obtain service, please call your installer or Glow-worm's own Service Organisation using the telephone number given on the controls tray.

Please be advised that the 'Benchmark' logbook should be completed by the installation engineer on completion of commissioning and servicing.

All CORGI Registered Installers carry a CORGI ID card, and have a registration number. Both should be recorded in your boiler Logbook. You can check your installer is CORGI registered by calling CORGI direct on :- 01256 372300.

## Boiler Clearances

If fixtures are positioned close to the boiler space must be left as shown in diagram 1.2. At least a minimum clearance of 500mm must be left in front of the boiler to allow for servicing.

## Boilers Installed in a Compartment or Cupboard

If the boiler is installed in a compartment or cupboard do not obstruct any ventilation openings.

Do not use the compartment or cupboard for storage.

## Cleaning

**WARNING:** This appliance contains metal parts (components) and care should be taken when handling and cleaning, with particular regard to edges.

Clean the casing occasionally by wiping it over with a damp cloth or dry polishing duster.

Do not use an abrasive cleaner.

## Boiler Electrical Supply

**WARNING:** This boiler must be earthed.

The boiler must only be connected to a 230V~50Hz supply protected by a 3A fuse.

All wiring must be in accordance with the current issue of BS7671.

Wiring to the boiler must be PVC insulated type to the current issue of BS6500 Table 16, not less than 0.75mm<sup>2</sup> (24/0.20mm).

The colours of three core flexible cable are:

Brown - live, Blue - neutral,

Green/yellow - earth.

As the markings on your plug may not correspond with these colours continue as follows:

The cable coloured blue must be connected to the terminal marked "N" or black.

The cable coloured brown must be connected to the terminal marked "L" or red.

The cable coloured green/yellow must be connected to the terminal marked "E", or green or the earth symbol  $\perp$ .

### To Light the Boiler

#### **WARNING:** Sealed Systems

A sealed water system must be filled and pressurised by a **competent person**.

Only light the boiler when you are sure that the system has been filled and pressurised.

The pressure gauge should show at least 0.7bar, anything less than this figure could indicate a leak and you **MUST** contact your installation/servicing company.

If there is any doubt about the boiler being full of water consult your installation/servicing company.

#### **ALL SYSTEMS.**

#### **Do not operate the boiler without water.**

Turn the electrical supply on to the boiler and check that all remote controls are calling for heat.

### To Turn the Boiler On

Remove the controls cover, by withdrawing it forward and off, see diagram 8.6.

Turn the control thermostat knob clockwise to any position between MIN and MAX. The maximum temperature setting is about 82°C (180°F), see diagram 8.1.

The boiler lighting operation is now automatic as follows.

The fan operates, followed by an ignition spark until the pilot is lit. When the pilot is alight the ignition system switches off and the main burner lights. The flames can be seen through the viewing window, see diagram 8.2.

The main burner will remain alight until switched off by the control thermostat or any remote control.

If the boiler is switched OFF, by hand, wait at least 30 seconds before switching on again.

When the boiler switches off, both the pilot and main burner go out.

The automatic lighting sequence will operate again when heat is required.

Refit the controls cover.

It should be noted that this is a fan flue appliance and fan operation may be heard.

### To Turn the Boiler Off

For short periods, turn the control thermostat knob anti-clockwise to "O" Off. To relight, turn the control thermostat knob to any position between "MIN" and "MAX".

For longer periods, turn the control thermostat knob fully anti-clockwise to "O" Off and switch off the electrical supply to the boiler.

To relight follow the lighting sequence given above.

### Protection Against Freezing.

If the boiler is to be out of use for any long period of time during severe weather conditions we recommend that the whole of the system, including the boiler, be drained off to avoid the risk of freezing up. Make sure that, if fitted, the immersion heater in the cylinder is switched off.

For the position of the serial number, see diagram 1.2.

# 1 General

## IMPORTANT NOTICE

This boiler is for use on **Natural Gas (G20)** as distributed in the United Kingdom and Ireland and cannot be used on any other gas. This boiler must be installed by a **competent person ONLY**.

This boiler can be used on an open vented or sealed water system.

When used on an open vented system domestic hot water can only be provided by pumped circulation to the indirect cylinder.

Wherever possible, all materials, appliances and components used shall comply with the requirements of applicable British Standards.

Where no British Standard exists, materials and equipment should be fit for their purpose and of suitable quality and workmanship.

## Sealed Components

Under no circumstances must the User interfere with or adjust sealed parts.

## Sheet Metal Parts

**WARNING:** When installing or servicing this boiler care should be taken when handling sheet metal parts, to avoid any possibility of personal injury.

## 1.1 Statutory Requirements

In GB the installation of the boiler must be carried out by a **competent person** as described in the following regulations:

The manufacturer's instructions supplied.

The Gas Safety (Installation and Use) Regulations.

The appropriate Buildings Regulations either The Building Regulations, The Building Regulations (Scotland), The Building Regulations (Northern Ireland).

The Water Fittings Regulations or Water byelaws in Scotland.

The Health and Safety at Work Act, Control of Substances Hazardous to Health (COSHH).

The Current I.E.E. Wiring Regulations.

Where no specific instructions are given, reference should be made to the relevant British Standard Code of Practice.

In IE, the installation must be carried out by a **competent person** and installed in accordance with the current edition of I.S.813 "Domestic Gas Installations", the current Building Regulations and reference should be made to the current ETCI rules for Electrical Installation.

In GB the following Codes of Practice apply:

BS4814, BS6798, BS5440 Part 1 and 2, BS5546 Part 1, BS5449, BS6891, BS6700, BS7074 Part 1 and 2, BS7593, BS7671.

In IE: I.S.813, BS5546, BS 5449, BS 7074, BS 7593.

Manufacturer's instructions must not be taken as overriding statutory requirements.

**NOTE:** For further information, see the current issue of the Building Regulations, approved document L1 (in the UK) and the references:

- 1) GIL 59, 2000: Central heating system specification (CheSS) and
- 2) GPG 302, 2001: Controls for domestic central heating system and hot water. BRECSU.

## 1.2 Data

See Table 1

All dimensions are given in millimetres (except as noted).

The Seasonal Efficiency Domestic Boilers UK (SEDBUK) is (100) 79, (120) 78.1.

The value is used in the UK Government's Standard Assessment Procedure (SAP) for energy rating of dwellings. The test data from which it has been calculated have been certified by B.S.I.

## 1.3 Range Rating

This boiler is range rated and may be adjusted to suit individual system requirements.

Diagram 1.2 gives the ratings and settings.

## 1.4 Testing and Certification

This boiler is tested and certificated for safety and performance. It is, therefore, important that no alteration is made to the boiler unless approved, in writing, by Glow-worm.

Any alteration not approved by Glow-worm, could invalidate the certification, boiler warranty and could also infringe the statutory requirements.

## 1.5 Gas Supply

The gas installation shall be in accordance with the relevant standards.

In GB this is BS6891.

In IE this is the current edition of I.S.813 "Domestic Gas Installations".

The supply from the governed meter must be of adequate size to provide a steady inlet working pressure of 20mbar (8in wg) at the boiler.

On completion test the gas installation for soundness using the pressure drop method and suitable leak detection fluid, purge in accordance with the above standard.

## 1.6 Electrical Supply

**WARNING:** This boiler must be earthed.

All system components shall be of an approved type and shall comply with and be connected in accordance with the current issue of BS7671 and any applicable local regulations.

External wiring must be correctly earthed, polarised and in accordance with the relevant standards.

In GB this is BS 6891.

In IE this is the current edition of I.S.813 "Domestic Gas Installations".

Connection of the boiler and system controls to the mains supply must be through a common isolator and must be fused 3A, maximum. This method of connection must be by a fused double pole isolating switch with a minimum contact separation of 3mm on both poles. The switch should be readily accessible and preferably adjacent to the appliance. It should supply the appliance only and be easily identifiable as so doing.

Alternatively, an unswitched shuttered socket outlet and 3A fused 3 pin plug both to the current issue of BS1363 may be used, provided that they are not used in a room containing a bath or shower.

Wiring to the boiler must be PVC insulated type to the current issue of BS6500 Table 16.

# 1 General

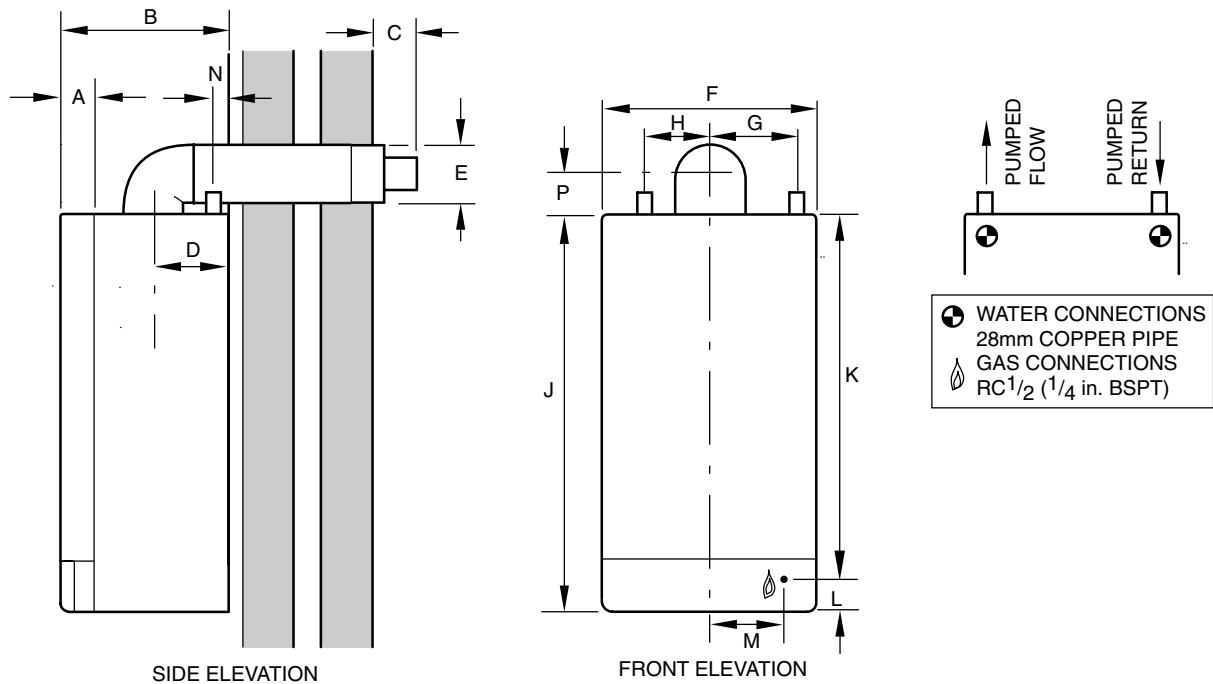

MODEL	A	B	C	D	E	F	G	H	J	K	L	M	N	P
100FF, 120FF	67	300	63	127	114	450	168	132.5	835	772	63	132	43	78.5

All dimensions are given in millimetres

Diagram 1.1

## 1.7 Contents of Packaging

The boiler is delivered in one pack.

Refer to Section 4.2 to check that the flue terminal assembly supplied is suitable.

## 1.8 Water System

This boiler may be fitted to an open vented or sealed water system.

It is recommended that plastic pipes for primary pipework should not be used for this boiler.

## 1.9 Drain

System

A draining tap must be provided at the lowest points of the system which will allow the entire system, boiler and hot water cylinder to be drained.

Draining taps should be to the current issue of BS2879.

Boiler

A draining point is fitted at the bottom right hand side of the heat exchanger.

Cover controls to avoid water damage.

If required remove the combustion chamber front cover to improve access.

## 1.10 Safety Valve

A safety valve need not be fitted to an open vented system.

## 1.11 Location

This boiler is not suitable for outdoor installation.

The boiler may be installed in any room, although particular attention is drawn to the requirements of BS7671 with respect to the installation of a boiler in a room containing a bath or shower. Any electrical switch should be so positioned that it cannot be touched by a person using the bath or shower. The electrical provisions of the Building Standards (Scotland) Regulations apply to such installations in Scotland.

This boiler is suitable for installation in bathroom zones 2 and 3.

In GB this is the current I.E.E. WIRING REGULATIONS and BUILDING REGULATIONS.

In IE reference should be made to the current edition of I.S.813 "Domestic Gas Installations" and the current ETCI rules.

The boiler must be mounted on a flat wall which is sufficiently robust to take its total weight.

The boiler may be fitted to a wall made of combustible material.

## 1.12 Boiler Clearances

Refer to diagram 1.3.

The boiler must be positioned so that at least the minimum operational and servicing clearances are provided.

Additional clearances may be required for installation.

If fixtures are positioned next to the boiler they should be made removable for access to pipework.

Sufficient clearance must be left in front of the boiler for servicing.

# 1 General

## 1.13 Room Ventilation

The boiler is room sealed and does not require the room or space containing it to have permanent airvents.

## 1.14 Boilers in a Compartment

Where the installation of the boiler will be in an unusual position, special requirements are needed, the current issue of BS6798 gives detailed guidance on these requirements.

A compartment used to enclose the boiler must be designed and constructed specifically for this purpose. An existing cupboard or compartment modified for the purpose may be used. Details of essential requirements for cupboard or compartment design are given in the current issue of BS6798.

The doorway opening should be of sufficient size to allow for easy removal of the boiler.

Where the boiler is fitted in a cupboard or compartment, permanent high and low level ventilation must be provided. The minimum ventilation areas are given in Table 2.

## 1.15 Timber Frame Building

If the boiler is to be installed in a timber frame building it should be fitted in accordance with the Institute of Gas Engineers document IGE/UP/7/1998. If in doubt seek advice from the local gas undertaking or Glow-worm.

## 1.16 Heating System Controls

The heating system should have installed: a programmer and room thermostat controlling the boiler.

Thermostatic radiator valves may be installed, however they must not be fitted in a room where the room thermostat is located.

**NOTE:** For further information, see The Building Regulations 1991 - Conservation of fuel and power, 1995 edition - Appendix G, table 4b.

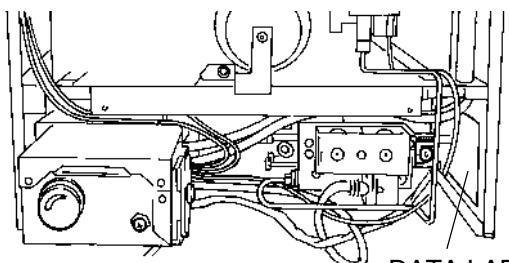

**DATA LABEL**

<b>Glow-worm</b>		HEPWORTH HEATING LTD., BELPER, DERBYS. DE56 1JT		458691
<b>MICRON 100FF</b>				
230V~ 50Hz 71W Fused at 3A For use on G20 gas only Supply pressure 20 mbar This boiler is intended exclusively to be installed on a gas supply with a governed meter.		GC No. 41-047-52		
CE 0086 GBIE		86/AO/035		
		INJECTOR: 4.7mm 205727		
<b>RANGE RATING</b>		MIN	MID	MAX
HEAT INPUT NETT Q =	kW Btu/h	26.44 90210	29.24 99760	32.38 110485
HEAT OUTPUT P =	kW Btu/h	23.45 80000	26.38 90000	29.31 100000
HOT BURNER PRESSURE	mbar in wg	9.2 3.7	11.6 4.7	14.4 5.8
Position ↑ against setting				
SERIAL No.				
<b>Glow-worm</b>		HEPWORTH HEATING LTD., BELPER, DERBYS. DE56 1JT		458721
<b>MICRON 120FF</b>				
Electrical Supply: 230V~ 50Hz Fused at 3A Electrical Power Rating 97W For use on Nat. gas (G20) only Supply pressure 20 mbar		GC No. 41-047-23		
CE 0086 GBIE		86/AP/035		
		INJECTOR: 5.2mm 205726		
<b>RANGE RATING</b>		MIN	MID	MAX
HEAT INPUT NETT Q =	kW Btu/h	33.43 114070	36.52 124610	39.61 135150
HEAT OUTPUT P =	kW Btu/h	29.31 100000	32.24 110000	35.17 120000
HOT BURNER PRESSURE	mbar in wg	9.9 4.0	12.0 4.8	14.2 5.7
Position ↑ against setting				
SERIAL No.				

Diagram 1.2

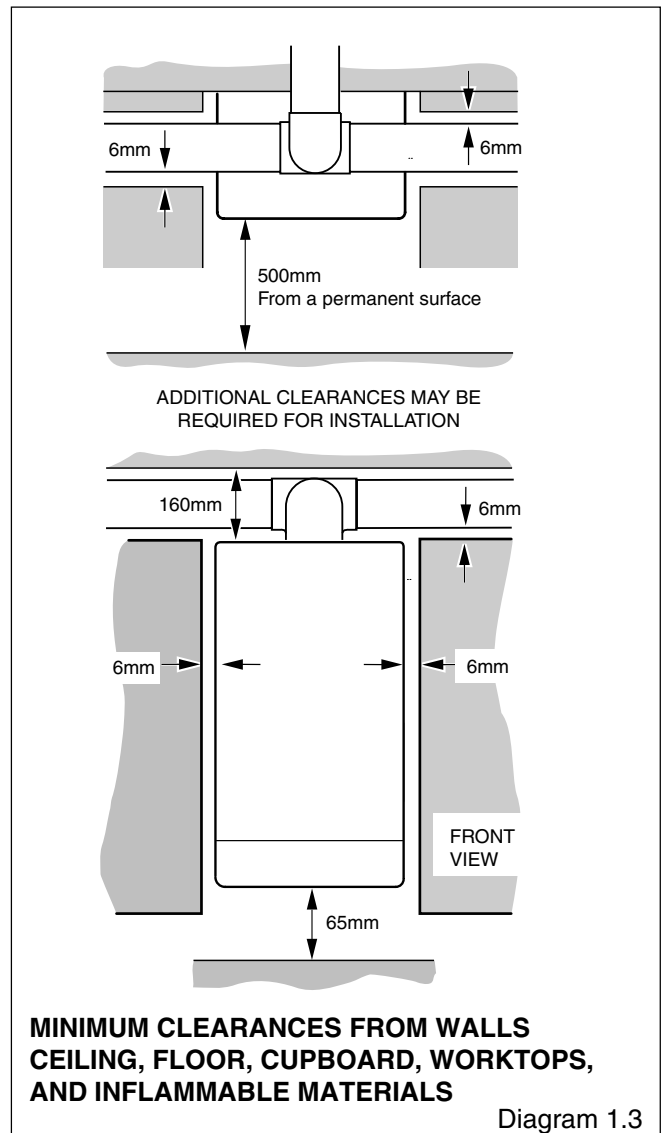

# 1 General

**\*NOTE:** Lift weight is with Flue Elbow, Controls Cover and Front Cover removed.

DATA TABLE 1.		
MODEL	100FF	120FF
TOTAL DRY WEIGHT (Including Terminal)	71.0 kg (157 lb)	71.0 kg (157 lb)
* LIFT WEIGHT	63.3 kg (140 lb)	63.3 kg (140 lb)
WATER CONTENT	3.8 litres (0.84 gal)	3.8 litres (0.84 gal)
GAS CONNECTION	Rc 1/2 in.	
ELECTRICITY RATING	71W	97W
	Internal fuse F1 & F2 (F1A)	
WATER CONNECTION	2x28mm copper pipes from top of case	
ELECTRICITY SUPPLY	230V~50Hz, fused 3A	
DATA LABEL	Bottom right hand side of case	

21907

TABLE 2. COMPARTMENT AIR VENTS					
VENTILATION REQUIREMENTS		HIGH LEVEL VENT AREA		LOW LEVEL VENT AREA	
	MODEL	cm <sup>2</sup>	in <sup>2</sup>	cm <sup>2</sup>	in <sup>2</sup>
VENTILATION FROM ROOM OR SPACE	100FF	330	51	330	51
	120FF	396	61.5	396	61.5
VENTILATION FROM OUTSIDE	100FF	165	25.5	165	25.5
	120FF	198	30.5	198	30.5

0209M

## 2 Flue Terminal

**NOTE:** Detailed recommendations for flues are given in the current issue of BS5440 Part 1.

### 2.1 Terminal Position

The minimum acceptable siting dimensions for the terminal from obstructions, other terminals and ventilation openings are shown in diagram 2.1. For Ireland the minimum distances for flue terminal positioning must be those detailed in I.S.813 "Domestic Gas Installations".

The terminal must be exposed to the external air, the position allowing free passage of air across it at all times.

Car ports or similar extensions of a roof only, or a roof and one wall, require special consideration with respect to any openings, doors, vents or windows under the roof. Care is required to protect the roof if it is made of plastic sheeting.

If the car port consists of a roof and two or more walls, seek advice from the local gas company before installing the boiler.

If the terminal is fitted within 600mm below plastic guttering or painted soffit an aluminium shield 1500mm long should be fitted immediately beneath the guttering or eaves. If the terminal is fitted within 450mm below painted eaves or a painted gutter, an aluminium shield 750mm long should be fitted immediately beneath the guttering or eaves.

### 2.2 Terminal Guard

A terminal guard is required if persons could come into contact with the terminal or the terminal could be subject to damage.

If a terminal guard is required, it must be positioned to provide a minimum of 50mm clearance from any part of the terminal and be central over the terminal, see diagram 2.2.

A suitable guard, reference Type K3, can be obtained from:

Tower Flue Components Ltd  
Morley Road  
Tonbridge  
Kent  
TN9 1RA

The installation of the boiler must comply with the requirements of the current issue of BS6798, in Ireland, refer also to the current edition of I.S.813 "Domestic Gas Installations".

In GB it is necessary to comply with the Water Supply (Water Fittings) Regulations 1999 (for Scotland, the Water Byelaws 2000, Scotland).

To comply with the Water regulations your attention is drawn to: The Water Regulations guide published by the Water Regulations Advisory Service (WRAS) gives full details of the requirements.

In IE the requirements given in the current edition of I.S.813 "Domestic Gas Installations" and the current Building Regulations must be followed.

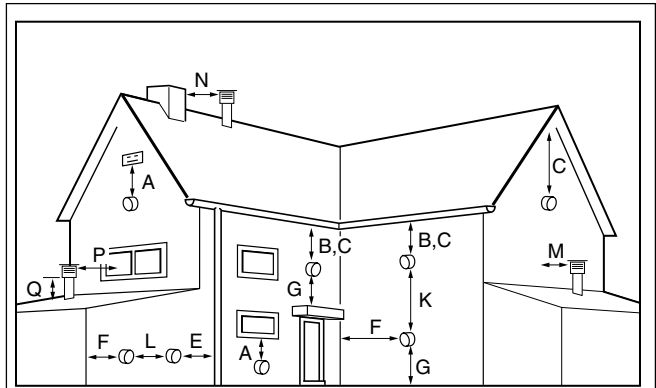
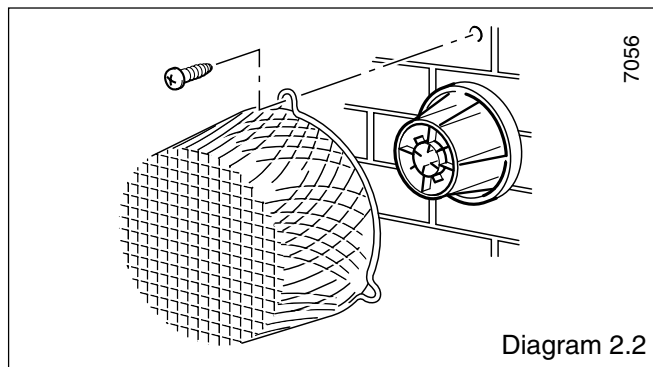

UNDER CAR PORT etc.

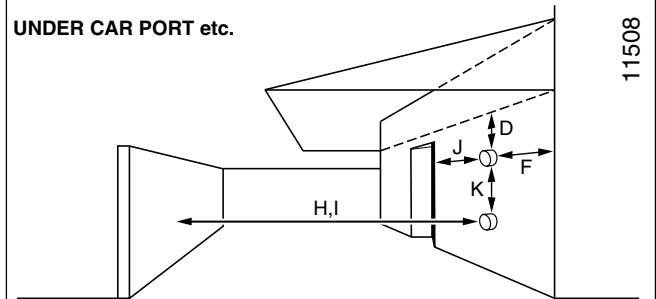

### MINIMUM SITING DIMENSIONS FOR FANNED FLUE TERMINALS POSITION MM

#### HORIZONTAL FLUES

A	DIRECTLY BELOW, ABOVE OR HORIZONTALLY TO AN OPENING, AIR BRICK, OPENING WINDOW, AIR VENT, OR ANY OTHER VENTILATION OPENING	300
B	BELOW GUTTER, DRAIN/SOIL PIPE	25
C	BELOW EAVES	25
D	BELOW A BALCONY OR CAR PORT	25
E	FROM VERTICAL DRAIN PIPES AND SOIL PIPES	25
F	FROM INTERNAL/EXTERNAL CORNERS OR TO A BOUNDARY ALONGSIDE THE TERMINAL	25
G	ABOVE ADJACENT GROUND OR BALCONY LEVEL	300
H	FROM SURFACE OR A BOUNDARY FACING THE TERMINAL	600
I	FACING TERMINALS	1200
J	FROM OPENING (DOOR/WINDOW) IN CAR PORT INTO DWELLING	1200
K	VERTICAL FROM A TERMINAL	1500
L	HORIZONTALLY FROM A TERMINAL	300

#### VERTICAL FLUES

M	FROM ADJACENT WALL TO FLUE	300
N	FROM ANOTHER TERMINAL	600
P	FROM ADJACENT OPENING WINDOW	1000
Q	ABOVE ROOF LEVEL	300

Diagram 2.1

## 3 Water Systems

### 3.1 Frost Protection

If the position of the boiler is such that it may be vulnerable to freezing it should be protected as specified in the current issue of BS5422. It is recommended that a frost protection thermostat be fitted.

### 3.2 Pump

The pump, with integral valves, should be fitted in the heating flow pipework from the boiler, it should be set to produce a temperature difference of 11°C (20°), between the flow and return, with the control thermostat set at "MAX", which is about 82°C (180°F).

The pressure loss of the boiler is 37.5 litre/min for the 100FF and 45litre/min for the 120FF to give 11°C temperature difference.

High resistance microbore systems may require a higher duty pump.

### 3.3 Bypass - Fully Pumped and Sealed Water System

A bypass MUST be fitted to a fully pumped and sealed water system.

Where the water system allows the boiler and pump to operate on bypass only, the bypass connection must be at least 2.5metres away from the boiler.

The flow through the boiler must not be allowed to fall such that there is a temperature difference greater than 20°C between the flow and return.

### 3.4 Water System

For an open vented system the boiler must be supplied from an unrestricted water supply taken from a feed and expansion cistern fitted at a maximum height of 27metres above the boiler.

The cold feed must be 15mm minimum size.

It is important that the relative positions of the pump, cold feed and open vent are as shown in diagram 3.1.

The unrestricted open vent from the boiler must rise continuously to over the feed and expansion cistern.

### 3.5 Domestic Hot Water System

**General** - All domestic hot water circuits, connections, fittings must be in accordance with the relevant standards and water supply regulations.

For GB: Guidance G17 to G24 and recommendation R17 to R24 of the Water Regulations Guide.

For IE: The current edition of I.S.813 "Domestic Gas Installations".

### 3.6 Indirect Cylinder

For all systems supplying domestic hot water the cylinder must be indirect. It is recommended that the indirect cylinder be fitted with some form of temperature control.

### 3.7 Fully Pumped Heating and Domestic Hot Water

The connections for this type of system MUST be as shown in diagram 3.1 and 3.2.

It is recommended that plastic pipes for primary pipework should not be used for this boiler.

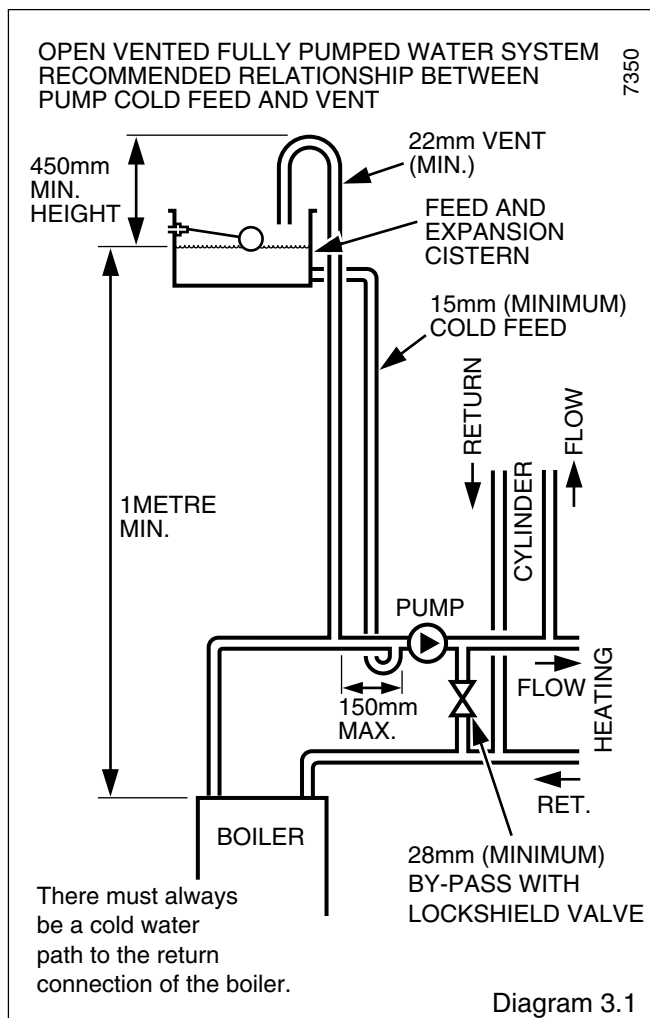

## 3 Water Systems

### 3.8 Inhibitor

Attention is drawn to the current issue of BS5449 and BS7593 on the use of inhibitors in central heating systems.

If an inhibitor is to be used, contact a manufacturer or Glow-worm, for their recommendations as to the best product to use.

When installing in an existing system take special care to drain the entire system, including the radiators, then thoroughly cleaning out before installing the boiler whether or not adding an inhibitor.

### 3.9 Sealed Water Systems

The installation should comply with the appropriate requirements of the current issue of BS4814, BS5449, BS6759, BS6798 and BS7074 Part 1 and 2.

### 3.10 Safety Valve

A safety valve must be fitted to a sealed water system.

It shall be preset, nonadjustable with a lift pressure of 3bar, incorporating seating of resilient material, a test device and a connection for drain.

The drain from the safety valve must be routed clear of any electrical fittings and positioned so that any discharge can be seen.

### 3.11 Expansion Vessel

A diaphragm type expansion vessel, conforming to the current issue of BS4814 (see also BS7074 Part 1 and 2) must be connected at a point close to the inlet side of the circulating pump, unless laid down differently by the manufacturer.

The expansion vessel volume depends upon the total water system volume and the initial system design pressure. For any system an accurate calculation of the vessel size is given in the current issue of BS7074 Part 1.

Example. For an initial system design pressure of 0.7bar the minimum total vessel volume required is  $0.063 \times \text{Total System Volume}$ .

**NOTE:** A higher initial design pressure requires a larger volume expansion vessel.

Guidance on vessel sizing is also given in the current issue of BS5449 and BS7074 Part 1, for IE refer to the current edition of I.S.813 "Domestic Gas Installations".

The charge pressure must not be less than the static head of the system, that is, the height of the highest point of the system above the expansion vessel.

The water content of the boiler is given in Data Table 1.

### 3.12 Pressure Gauge

A pressure gauge with a set pointer and covering at least the range of 0 to 4bar (0 to 60lb/in<sup>2</sup>) shall be permanently fitted to the system in a position where it can be seen when filling the system.

### 3.13 Domestic Hot Water Cylinder

**SINGLE FEED INDIRECT CYLINDERS ARE NOT SUITABLE.**

The domestic hot water cylinder must be if the indirect coil type. It must be suitable for working at a gauge pressure of 0.35bar above the safety valve setting.

### 3.14 Domestic Hot Water System - Unvented

Where a storage system will not have a vent to atmosphere the installation must comply with Building Regulations and the Local Water Company Byelaws, see also the current issue of BS6700.

If fitting into an existing system, the local authority must also be advised.

### 3.15 Filling a Sealed Water System

Provision for filling the system at low level must be made.

The installation should comply with the appropriate requirements of the current issue of BS 5449.

### 3.16 Water Make-up

Provision must be made for replacing water lost from the system. A make up vessel mounted above the highest point of the system and connected through a non-return valve to the system on the return side of either the hot water cylinder or heating system.

Alternatively provision for make up can be made by a filling loop.

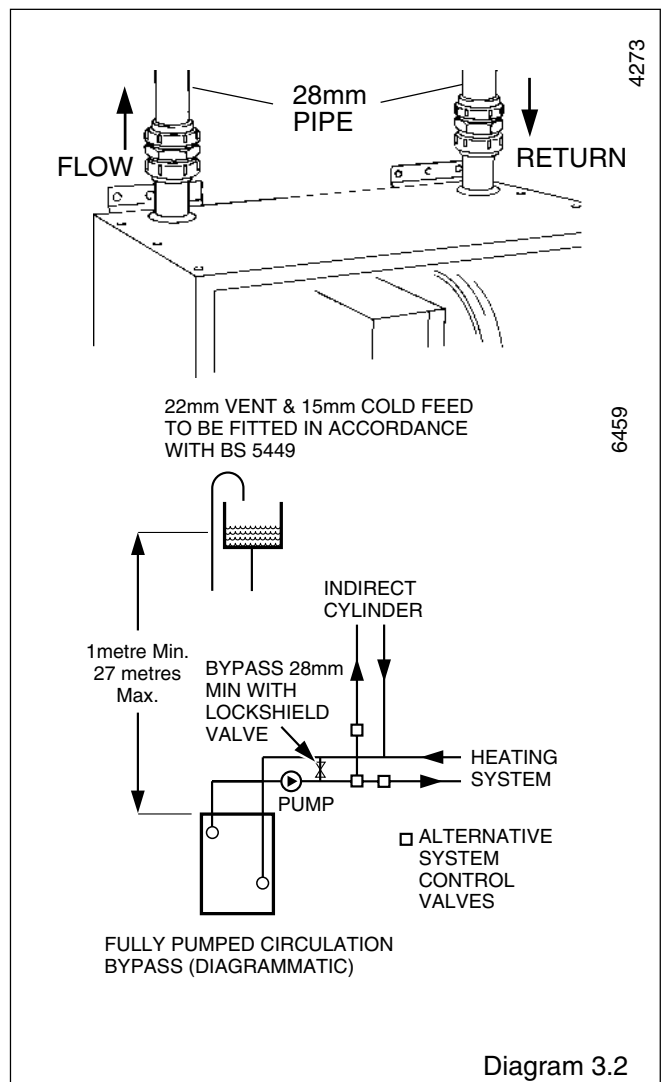

## 4 Flue and Appliance Preparation

### 4.1 Unpacking

Open the carton, check the items supplied against the boiler pack contents list on the flap.

### 4.2 Flue Position and Length

There are various flue systems to choose from, as follows:

Standard Flue Pack - Pt.No. 230515

A Flue Bend Kit up to 2 metres and a Vertical Flue Kit up to 2 metres plus vertical terminal can be supplied, see Glow-worm "Flue Options Guide" for configurations available.

45° Flue Bend Pack - Pt.No. 448696

90° Flue Bend Pack - Pt.No. 448695

Vertical Flue Kit No. - 2000448455

Determine flue applications, length and terminal position before starting.

Refer to diagram 4.1 or 4.2.

**NOTE:** If a longer flue duct is required DO NOT extend the telescopic flue beyond its maximum length.

A 1, 2 or 3 metre flue system and terminal MUST be used, for the 100FF and 1 or 2 metre only for the 120FF.

**NOTE:** If required, an optional Wall Liner Kit, part No.452481, is available, complete with fixing instructions.

### 4.3 Flue Preparation

All flue assemblies are designed for internal installation (optional wall liner is required), given that there is sufficient clearances opposite to the flue for the installation of the flue.

If there is insufficient clearance the flue can be installed from outside.

For a wall thickness up to 300mm, provided that there is sufficient space and the optional wall liner kit is used the flue can be fully installed from the inside.

For a wall thickness of over 300mm the external flue hole will need to be made good from the outside. This applies also if you use the flue kit without the optional kit, irrespective of wall thickness.

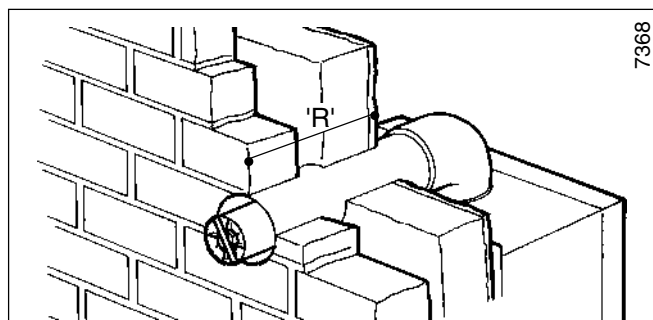

Standard Flue terminal illustrated.

#### REAR FLUE LENGTHS

Distance R = Wall thickness

STD.	75mm to 519mm
1M	75mm to 928mm
2M	75mm to 1928mm
*3M	75mm to 2928mm      *100FF ONLY

Diagram 4.1

### 4.4 Rear and Side Flue Application

Take the template from the boiler pack and position it on the wall, making sure that the minimum clearances are maintained, see diagram 1.3.

For a rear flue mark the position of the flue as diagram 4.3.

For a side flue, extend the centre line horizontally left or right to the corner of the adjacent surface where the flue is required to exit. Mark the position of the centre of the flue and boiler, then remove template as diagram 4.3.

### 4.5 Flue Hole Cutting

Having marked out the flue centre cut a hole for the flue using, preferably, with a core drill.

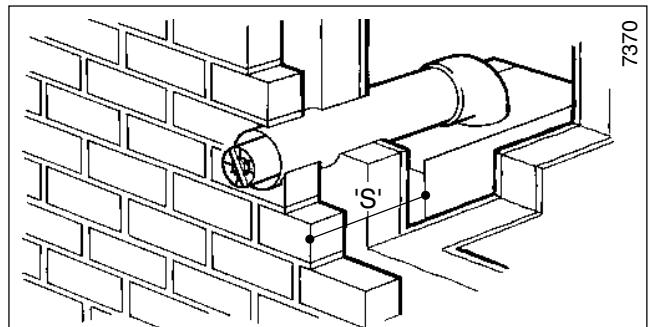

Standard Flue terminal illustrated.

#### SIDE FLUE LENGTHS

Distance S = External wall face to boiler case

STD.	81mm to 439mm
1M	81mm to 830mm
2M	81mm to 1830mm
*3M	81mm to 2830mm      *100FF ONLY

Diagram 4.2

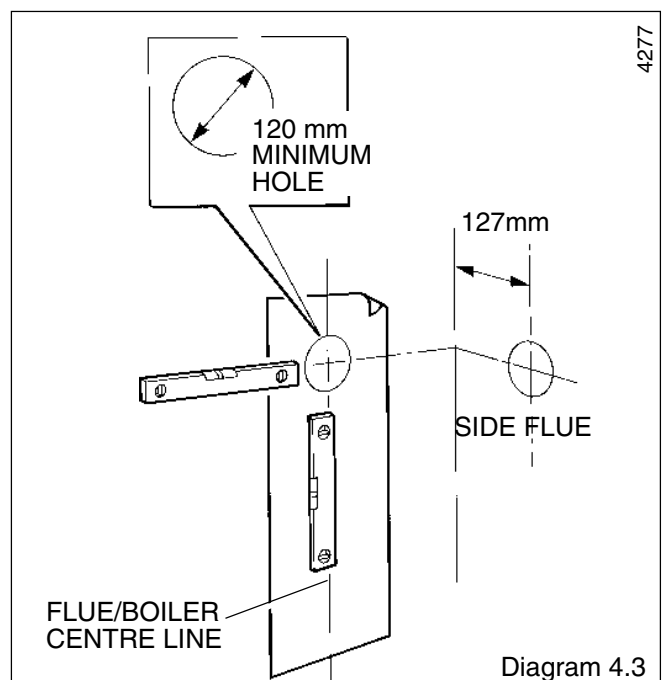
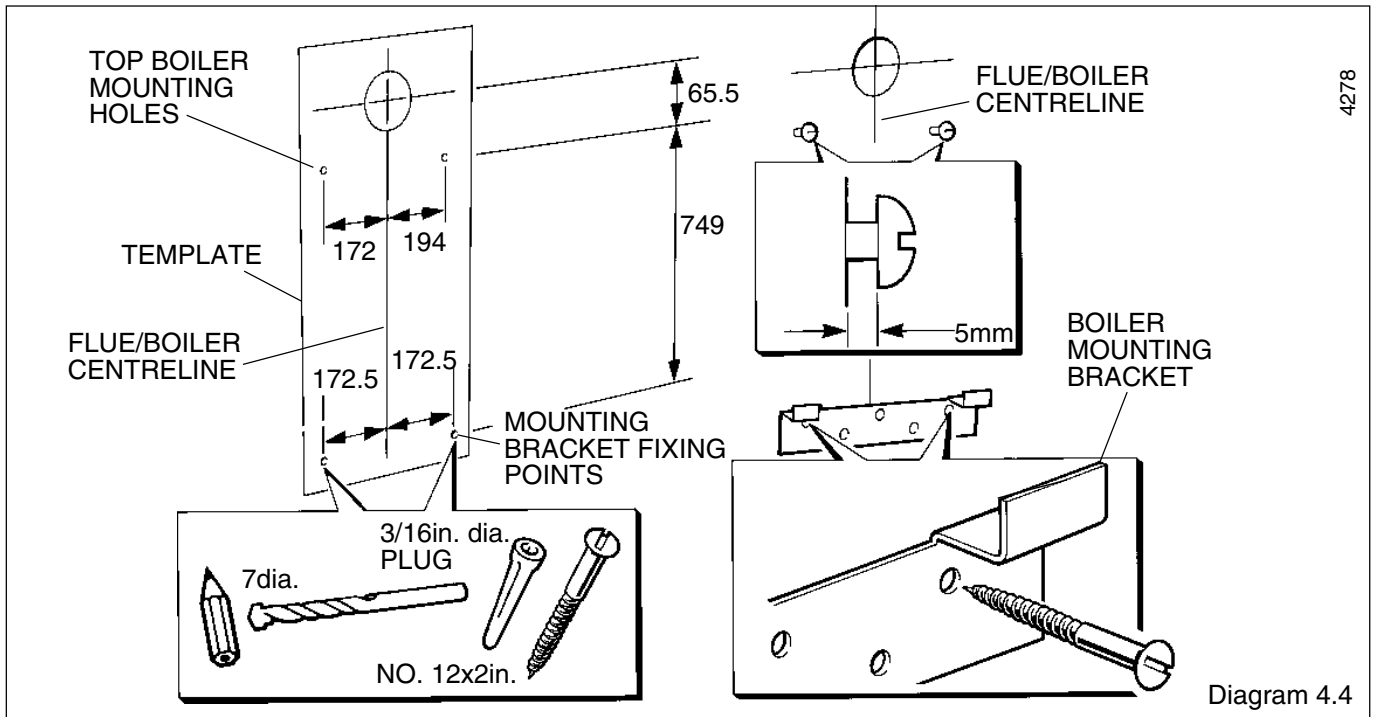

Diagram 4.3

## 4 Flue and Appliance Preparation



### 4.6 Wall Mounting Bracket

Reposition the template, making sure of dimensional alignment with the flue hole.

Mark the boiler fixing points and mounting bracket position, see diagram 4.4.

**NOTE:** the mounting bracket has additional holes to allow for further fixings should site conditions require it.

Drill holes and plug, to suit No.12x2in woodscrews, fit the screws allowing sufficient clearance, about 5mm, to accept the swing brackets, see diagram 4.4.

Secure the mounting bracket to the wall with No.12x2in woodscrews and plugs, see diagram 4.4.

If the boiler is not to be fitted for some time, cover the hole in the wall.

### 4.7 Flue Length

For a rear flue, measure the distance from the outside wall face to the boiler mounting wall. Check that the flue length will be suitable, see diagram 4.2.

For a side flue, measure the distance from the outside wall face to the boiler centre line. Check that the flue length will be suitable, see diagram 4.3.

Extend the standard telescopic flue to the required length, making sure that the minimum overlap is no less than 25mm, and that the flue terminal projects 15mm minimum beyond wall face, see diagram 4.5.

Carefully drill through the hole at the side of the flue, secure with self tapping screw, see diagram 4.6.

Seal the joint with the provided tape.

All 1, 2 and 3 metre flue systems are installed in a similar manner to the standard telescopic flue.

**NOTE:** Should any one of the 1, 2, or 3 metre flue systems require cutting to obtain desired flue system length, do not cut at the pre-drilled end. The standard telescopic flue is not pre-drilled.

Make sure to cut square and remove any burrs.

If the boiler is not to be fitted for some time cover the hole in the wall.

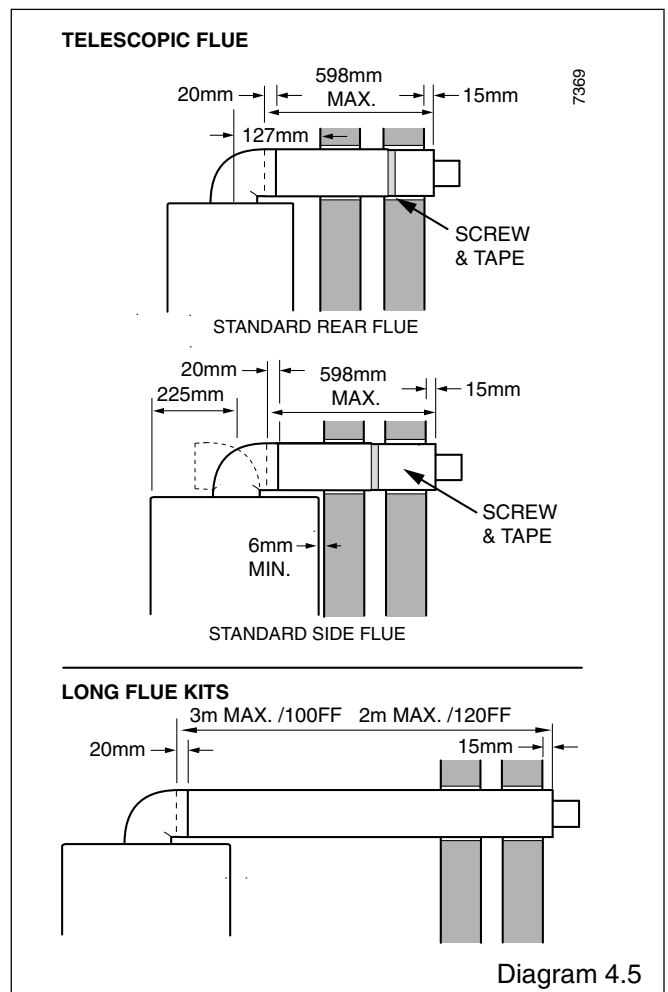

### 4.8 Rear Flue

Mark the air duct/terminal assembly and the flue duct at the length shown in diagram 4.5 then cut to length.

**NOTE:** Owing to its variable length the standard telescopic flue may not need cutting.

## 4 Flue and Appliance Preparation

### 4.9 Side Flue

Mark the air duct/terminal assembly and the flue duct at the lengths shown in diagram 4.5 then cut to length, cutting square and removing any burrs.

**NOTE:** Owing to its variable length the standard telescopic flue may not need cutting.

### 4.10 Flue Assembly

Locate the flue duct (drilled end) onto the flue elbow and secure with the screws supplied in the loose items pack, see diagram 4.6.

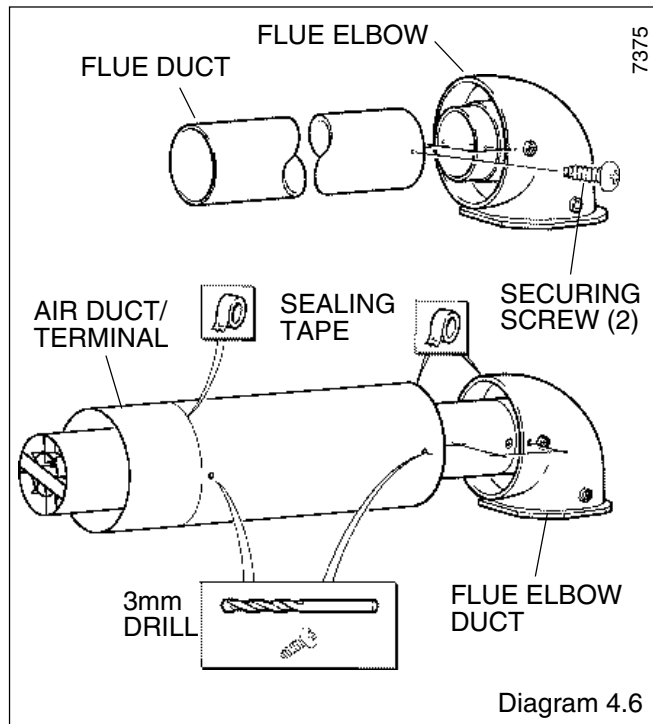

**NOTE:** The telescopic flue assembly will require drilling.

Locate the flue duct/elbow into the air duct/terminal spigot and the air duct/terminal into the flue elbow making sure the correct alignment of top. Drill the air duct and secure/seal (external fixing, do not seal) as shown in diagram 4.6.

### 4.11 Wall Liner

If a wall liner is used, fit foam seal as diagram 4.7.

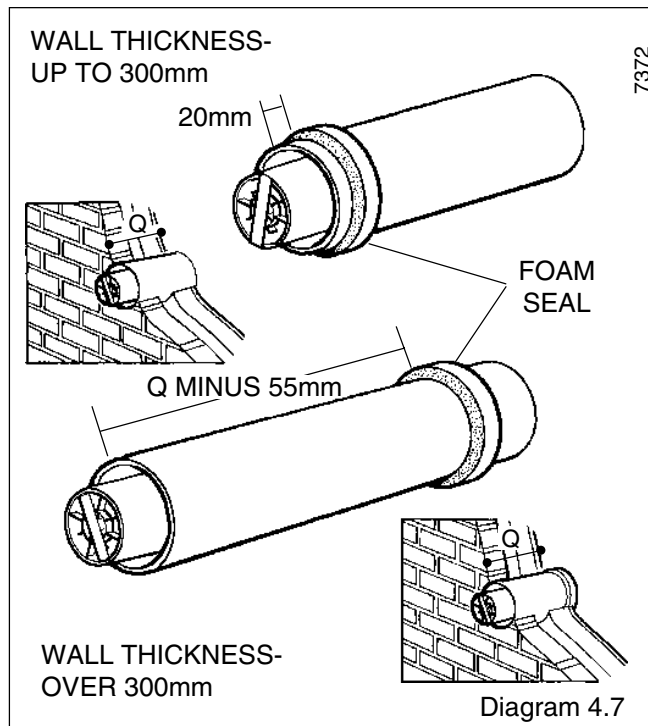

## 5 Boiler Installation

### 5.1 Boiler Preparation

With the boiler still in the bottom tray, slide the controls cover upwards and remove it as shown in diagram 5.1.

Remove the front cover by undoing (and keeping) the wing nut, nut and shakeproof washer, then lift the front cover off, see diagram 5.1.

Place the front cover on one side until required, having removed the polystyrene packing piece.

Fit suitable compression fittings to the boiler connections.

### 5.2 Mounting the Boiler

Make sure that the top, swing brackets are UPRIGHT.

Lift the boiler into position, hooking over the mounting bracket.

Swing the brackets over the two screws at the top. Hold the swing bracket(s) in place whilst tightening the screw(s) on to it, see diagram 5.2.

Remove the blue and red electrical connections from the fan, see diagram 5.3.

Break the air pressure switch tube connections from the fan, see diagram 5.3.

Remove the fan assembly by removing the screws and sliding out, see diagram 5.3. Take care not to damage the gasket.

Slacken, but do not remove, the flue hood securing screws, see diagram 5.4.

### 5.3 Water Circulation System

Complete the water connections to the boiler.

Fill, vent and flush system.

Check for any leaks and put right.

### 5.4 Safety Valve Discharge

Fit a suitable discharge pipe to the safety valve and route it outside the building so that any discharge can be seen but will not cause injury to person, damage to property or any electrical installation.

### 5.5 Gas Connection

Make the gas connection to the Rc 1/2 in gas service cock, see diagram 5.5.

The whole of the gas installation, including the meter, should be inspected, tested for soundness and purged in accordance with the current issue of BS6891 and in IE the current edition of I.S.813 "Domestic Gas Installations".

# 5 Boiler Installation

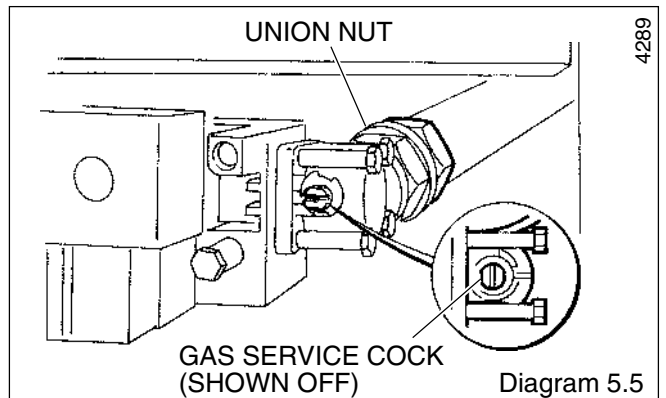
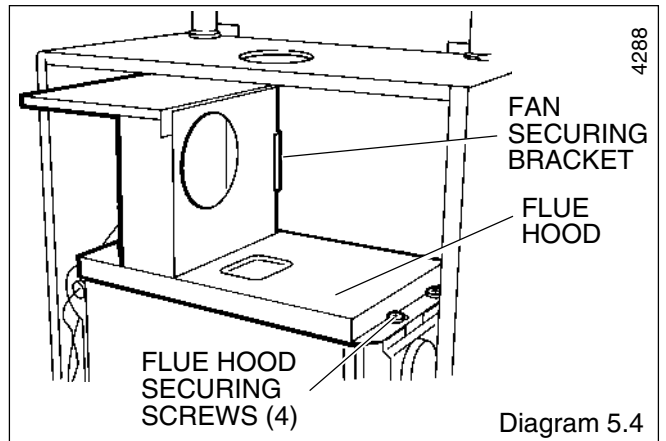
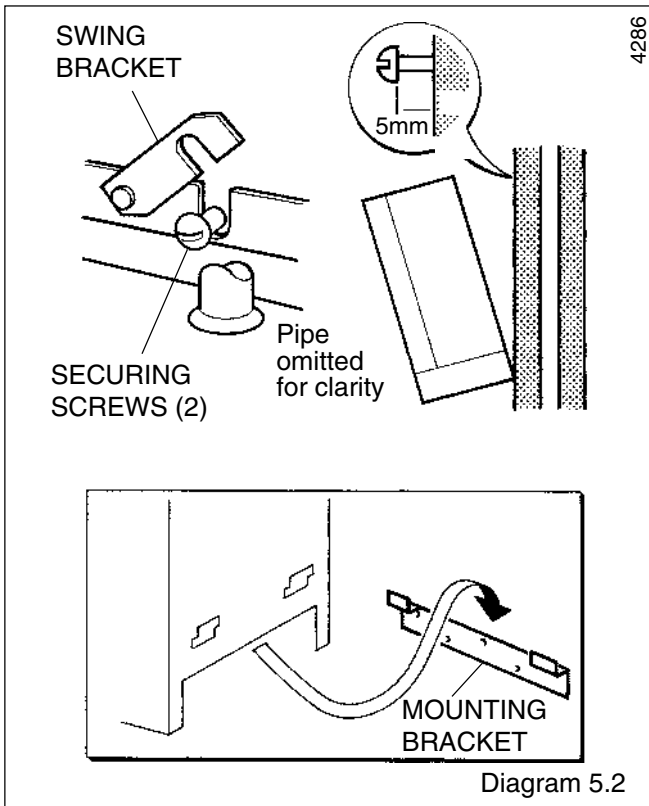
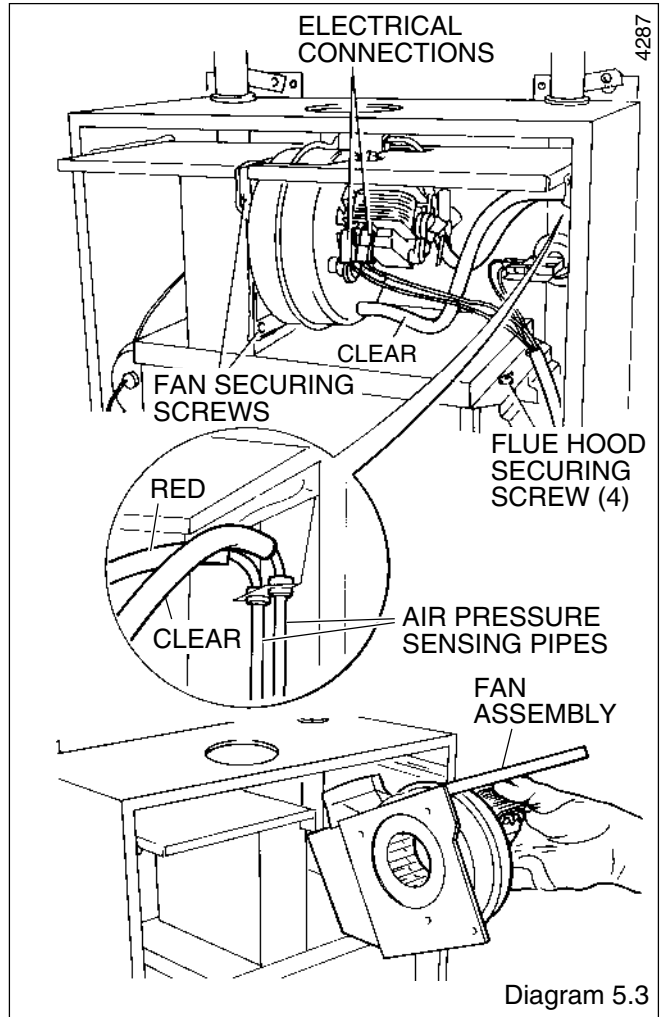
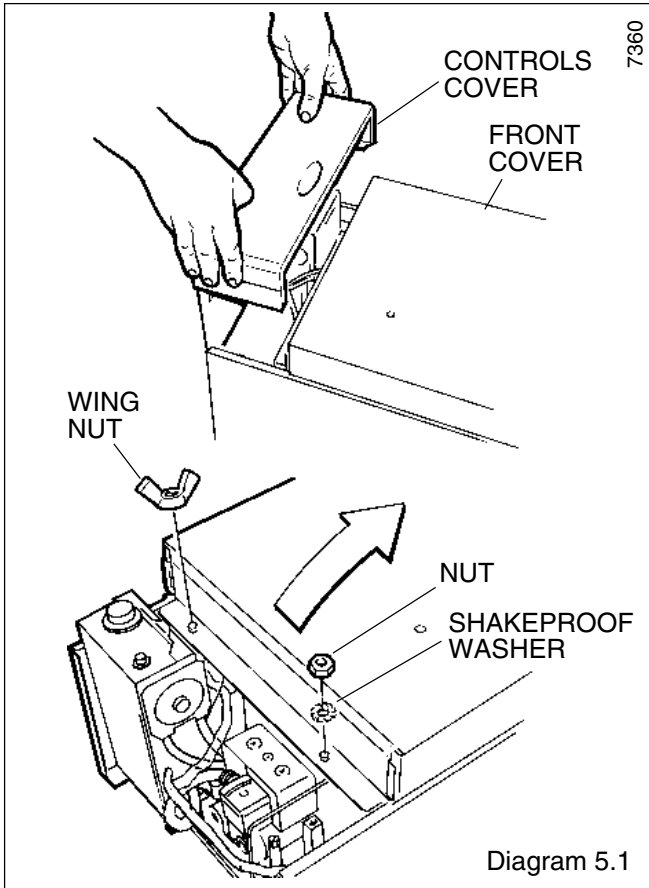

## 6 Flue Fixing

**NOTE:** If external flue fixing is required start at 6.2.

### 6.1 Flue Fixing - Internal

**NOTE:** Use of the optional wall liner kit is required.

Place the flue assembly into the hole. Check that the flue terminal is correctly positioned and is the distance required from the outside wall face, see diagram 6.1.

Position flue elbow gasket and secure the flue assembly to the boiler using the dogpoint screws, see diagram 6.2.

Make sure of the correct fitting of the flue to the boiler.

Now continue at Section 6.3.

### 6.2 Flue Fixing - External

Remove the flue elbow from the air duct/terminal and flue duct, by removing and keeping, the securing screw(s).

From outside place the air duct/terminal and flue duct assembly into the hole and make sure that the flue terminal is correctly positioned and is the distance required from outside wall face, see diagram 6.1.

Position flue elbow gasket and secure the flue elbow to the boiler using the dogpoint screws, see diagram 6.2.

Make sure of the correct fitting of the flue to the boiler.

Pull the flue duct forwards and engage onto the flue elbow.

Push the air duct back into the wall to the dimension shown in diagram 6.3.

Important, the flue duct will become disengaged should the dimension be any greater than shown.

Hold the flue duct onto the flue elbow, then, secure the flue duct to the flue elbow, see diagram 6.3.

Pull the air duct back to engage with the flue elbow and secure/seal.

### 6.3 All Flue Installations

Fit the fan to the flue elbow spigot and secure with the screws previously removed.

Reconnect the blue and red electrical connections to the fan, the polarity of the connections is not important.

Reconnect the air pressure switch tubes as shown in diagram 5.3.

Secure the flue hood, see diagram 5.4.

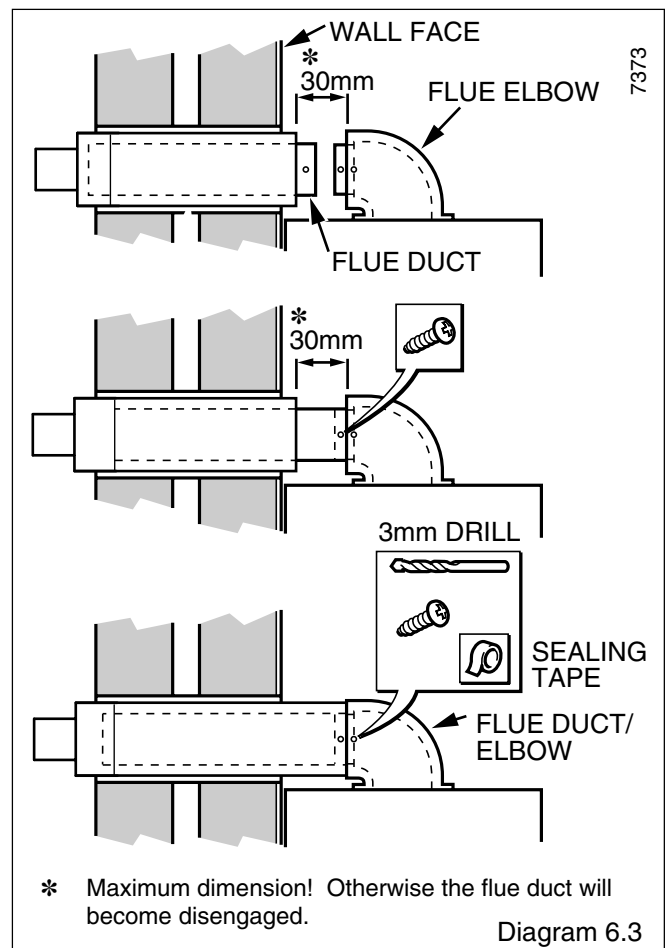
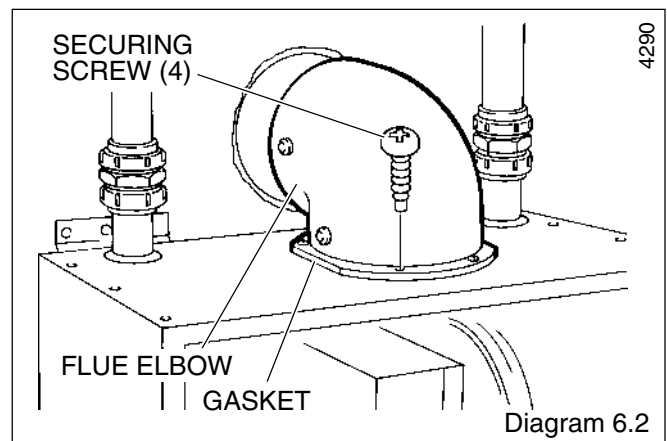
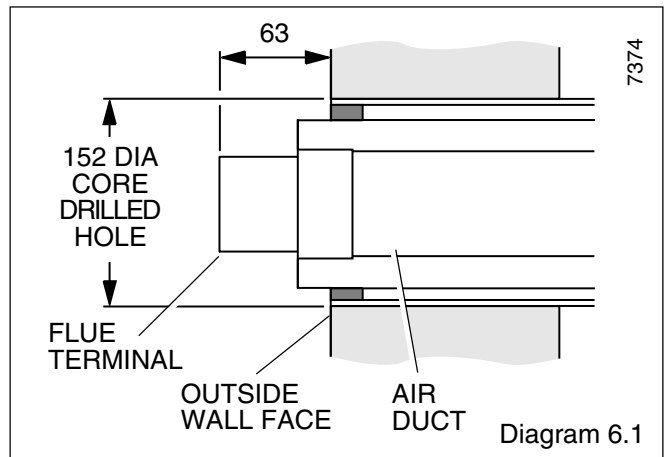

## 7 Electrical Connectors

### 7.1 Control Box Removal

Remove the electrical control box securing screws, see diagram 7.1. Slide the box forwards and release, hook it onto the lip bracket at the front, see diagram 7.1.

### 7.2 Electrical Connection

**WARNING:** This boiler must be earthed.

Take care not to damage any internal wiring and capillaries.

Take the plastic cable retaining clip, from the loose items pack, peel off the backing paper and position it in a suitable place to secure the incoming cable.

Using heat resistant (to 85°C) cable of at least 0.75mm<sup>2</sup> (24/0.2mm) to the current issue of BS6500 Table 16 and of suitable length, thread through the cable clamps, secure into the plastic clips and connect to appropriate terminals, see diagram 7.2 and 11.5.

Standard colours are, brown - live (L), blue - neutral (N) and green and yellow - earth (E).

Make sure the cable is suitably secured.

When making connections, make sure that the earth conductor is made of a greater length than the current carrying conductors, so that if the cable is strained the earth conductor would be the last to become disconnected.

**NOTE:** Open Vented Water Systems ONLY.

Bridge terminals K1 and K2.

### 7.3 Pump Connection

The pump must be connected directly to the control box, as shown in diagram 7.2, threading the cable through the cable clamp in the side of the control box.

### 7.4 External Controls

Any external controls must only be wired to interrupt the red link between terminals SL and 9.

Make sure that the supply cable and all external cables are secured and away from hot surfaces.

### 7.5 Testing

Checks to ensure electrical safety must be carried out by a **competent person**.

After installation of the system, preliminary electrical system checks as below should be carried out:

1. Test insulation resistance to earth.
2. Test earth continuity and short circuit of all cables.
3. Test the polarity of the mains.

The installer is requested to advise and give guidance to the user of the controls scheme used with the boiler.

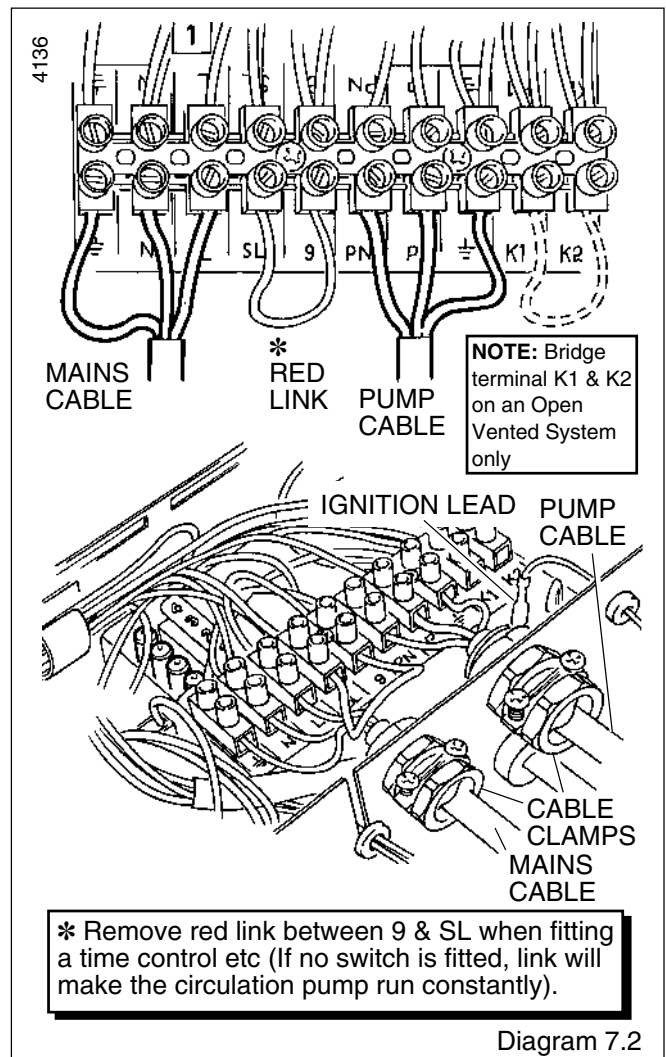
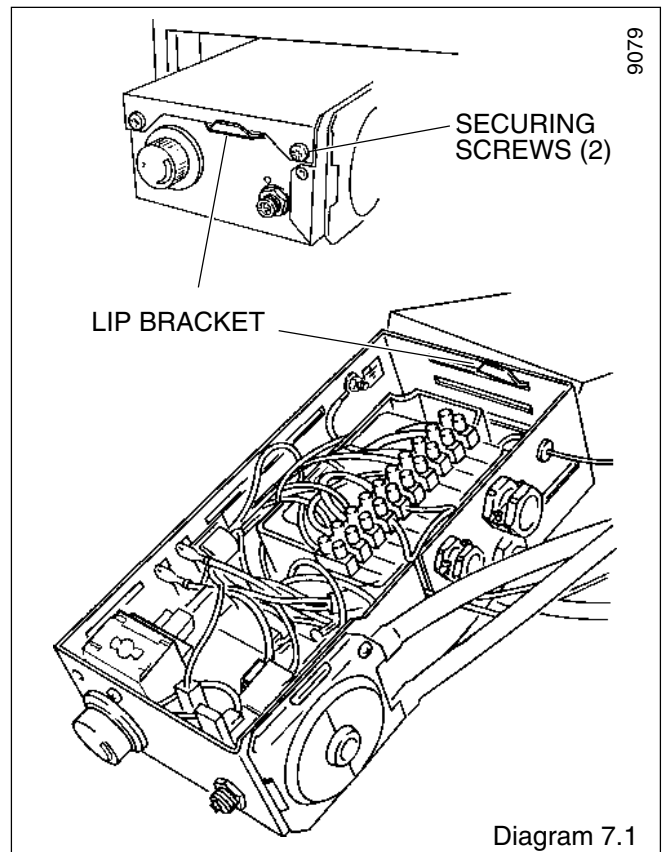

## 8 Commissioning

**IMPORTANT NOTE:** The warning notice attached to the front of the boiler casing must only be removed by the user.

Please ensure the "Benchmark" logbook is completed and left with the user.

### 8.1 All Systems

Commissioning should be carried out by a **competent person** in accordance with the current issue of BS6798.

**WARNING:** Do not operate the boiler without water.

Make sure that the system has been thoroughly flushed out with cold water without the pump in place.

Refit the pump, fill the system with water, making sure that all the air is properly vented from the system and pump.

Before operating the boiler check that all external controls are calling for heat.

### 8.2 Sealed Water Systems Only

Flush the whole system with cold water without the pump in place. Refit the pump and fill until the pressure gauge registers 2.7bar (40lbf/in<sup>2</sup>). Clear any air locks and check for water soundness.

Check the operation of the safety valve, by allowing the water pressure to rise until the valve opens. The valve should open within  $\pm 0.3\text{bar}$  ( $\pm 4.3\text{lbf/in}^2$ ) of the preset pressure. Where this is not possible conduct a manual check and test.

Release cold water to initial system design pressure.

The set pointer on the pressure gauge should be set to coincide with the indicating pointer.

### 8.3 Initial Lighting and Testing

**CAUTION:** This work must be carried out by a **competent person**, in accordance with the current issue of BS6798.

Make sure that all naked lights and cigarettes are out.

Identify the controls by reference to diagram 8.1.

Check that the boiler is isolated from the electrical supply.

Make sure that the control thermostat is turned to "O" the "Off" position.

Turn boiler gas service cock "On".

Test the pilot supply tube and its connection for gas soundness as follows:

Disconnect the ignition lead from the PCB, see diagram 7.2.

Remove the combustion chamber front, see diagram 8.2.

**WARNING:** The fan operates on mains voltage, terminals will become live.

Turn the electrical supply on and check that all remote controls are calling for heat.

Check that the pump is circulating water through the system.

To complete the test it is necessary to operate the boiler without its case, but **UNDER ALL OTHER CIRCUMSTANCES** the case must be correctly fitted and sealed.

Turn the control thermostat knob fully clockwise and the fan will work.

**NOTE:** There will be no sparks at the pilot. Take care and light the pilot with a match.

Test the pilot supply and connections for gas soundness, using a suitable leak detection fluid.

Very cold weather may delay the operating sequence.

The pilot rate is preset and must not be adjusted.

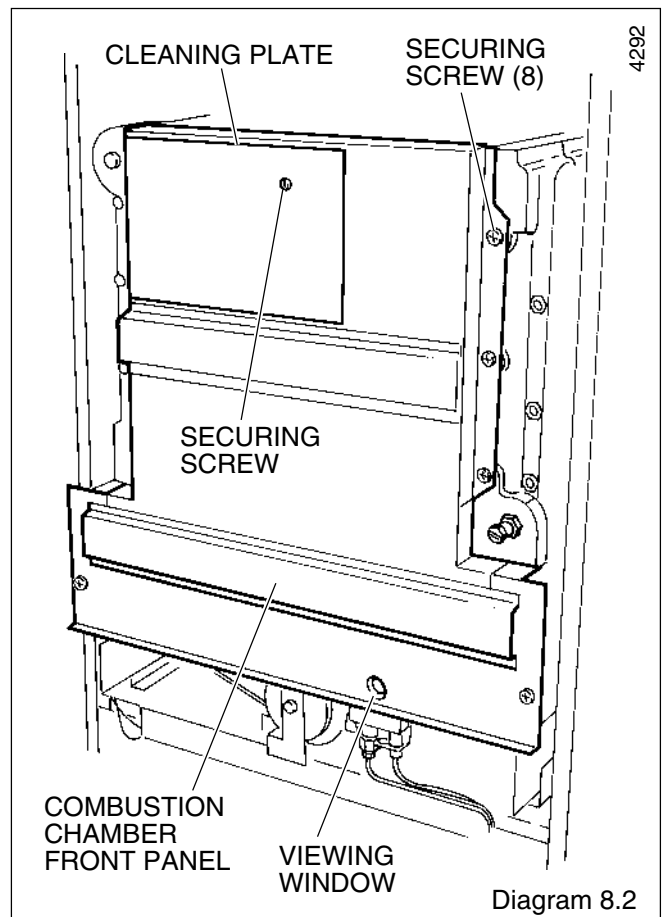
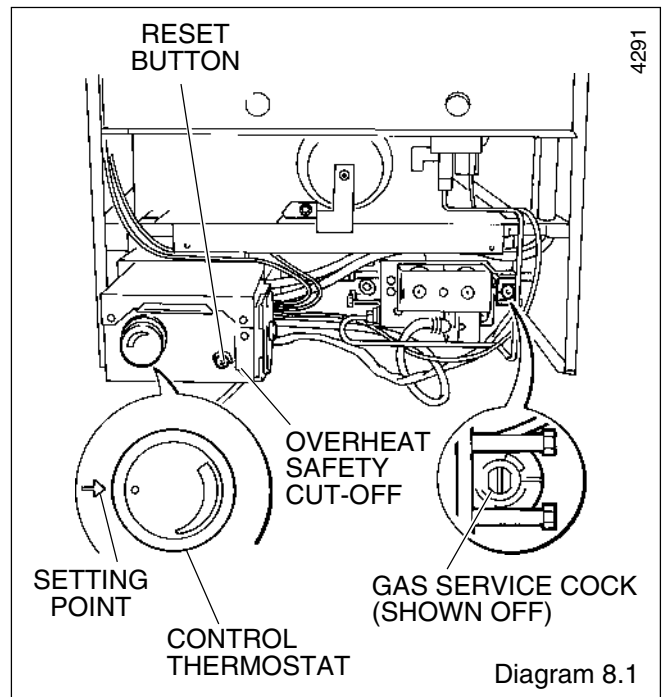

## 8 Commissioning

The step adjustment screw must not be touched.

The pilot flame length should be as shown in diagram 8.3.

Turn the control thermostat knob to "O" and isolate the boiler from the electrical supply.

Fit the combustion chamber front.

Reconnect the ignition lead to the PCB.

For future reference, stick the self adhesive arrow indicator to the data label, against the rating that the boiler is going to be set to. The arrow is in the loose items pack.

Loosen the main burner pressure test point screw and connect a suitable pressure gauge, see diagram 8.4.

Make sure that any remote controls are calling for heat.

Switch on/connect the electrical supply to the boiler and heating system, neon 1 will light.

### 8.4 Testing - Electrical

Turn the control thermostat knob fully clockwise to the maximum setting, which is about 82°C (180°F), neon 2 will light.

The lighting sequence is automatic as follows:

The fan operates	}	Neon 3 will light
The Spark ignition operates		
The pilot solenoid opens		
The pilot burner lights		
The ignition spark stops	}	Neon 4 will light
The main solenoid opens		

and after a short period of time the main burner will light, look through viewing window, see diagram 8.2.

The main burner will stay alight until switched off, either by the control thermostat or a remote system control.

To make sure that the flame supervision device is working correctly the following should be done:

1. With the main burner alight, turn the gas service cock "Off", see diagram 8.1.

After a short period the main burner and pilot will go out.

2. The correct working of the flame supervision device is shown by neon 4 going out within 10 seconds and the ignition starting up.

Neons 1, 2, and 3 should stay alight.

3. If the above does not happen, refer to fault finding Section 11.1.

4. To carry on turn the gas service cock "On", see diagram 8.1.

When the boiler switches "Off", both the pilot and the main burner go out. The automatic lighting sequence will work again when heat is required.

### 8.5 Testing - Gas

With the boiler on proceed as follows:

Test for gas soundness around the boiler gas components using a suitable leak detection fluid, in accordance with the current issue of BS6891.

Check the main burner gas pressure at least 10 minutes after the boiler has lit, refer to Data Label.

If necessary adjust the gas pressure to obtain the required setting turning the screw clockwise, to decrease pressure, see diagram 8.4.

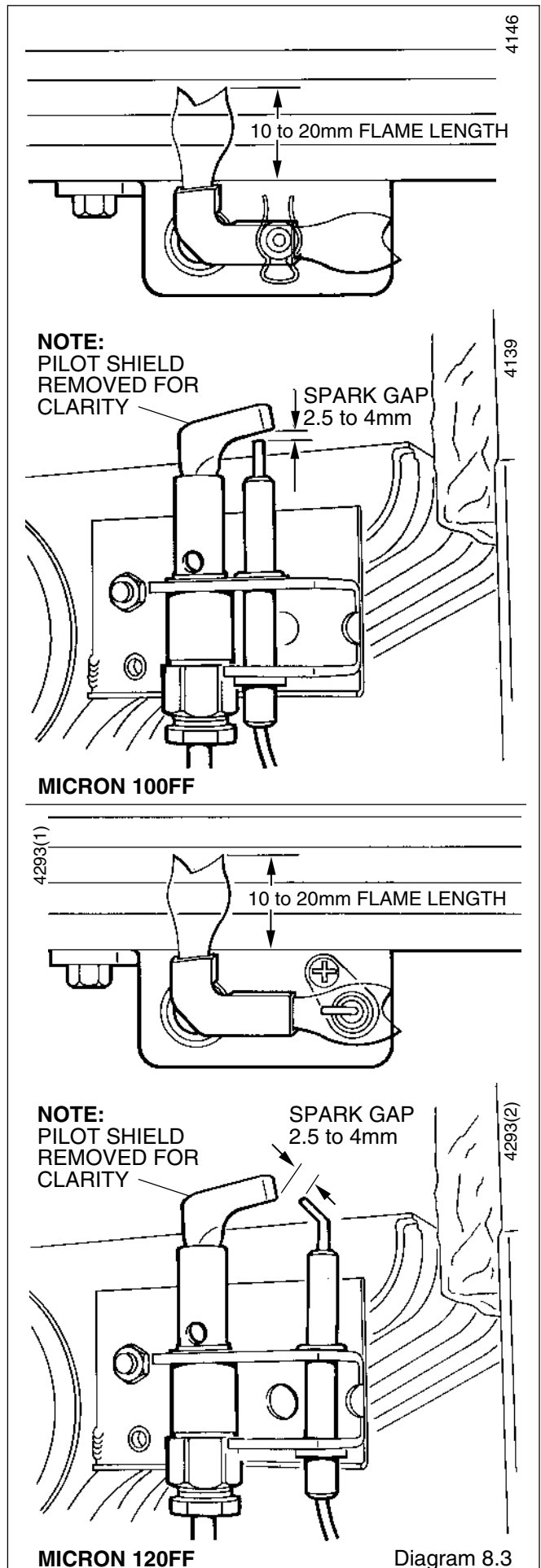

## 8 Commissioning

Should any doubt exist about the gas rate, check it using the gas meter test dial and stop watch, at least 10 minutes after the burner has lit, making sure that all other gas burning appliances and pilot lights are off.

The gas rates shown in Table 3 are for guidance only, dependent on the heat setting.

Turn the control thermostat knob fully anticlockwise to "O". Remove the pressure gauge from the test point and refit screw, making sure a gas tight seal is made.

When the control thermostat is turned to "Off" position, by hand, wait at least 30 seconds before turning "On" again.

There may be an initial smell given off from the boiler, this is quite normal and will disappear after a short period of time.

Refit the electrical controls box, see diagram 7.1.

**NOTE:** The neon indicators on the printed circuit board are an aid to fault finding, for details refer to Section 11.

### 8.6 Testing - Open Vented

Allow the system to reach maximum working temperature and examine for water leaks.

There should be no undue noise in the system and no pumping over of water or entry of air at the open vent above the feed and expansion cistern.

All systems. The boiler should be turned off and the system drained off as rapidly as possible, whilst still hot.

### 8.7 Adjustment - Fully Pumped Open Vented and Sealed Water Systems

When commissioning the system the boiler should first be fired with the bypass fully closed on full service, that is, central heating and domestic hot water. Adjust the pump to the system design setting then balance the system. Having achieved a satisfactory condition operate the boiler with the bypass fully closed on minimum load, normally this will be central heating only with one radiator in the main living area operating. The bypass valve should be gradually opened to achieve a temperature difference no greater than 20°C between the flow and return.

**UNDER NO CIRCUMSTANCES SHOULD THIS VALVE BE LEFT IN THE FULLY CLOSED POSITION.**

### 8.8 Sealed Water System ONLY

Adjust system to initial design pressure. The set pointer on the pressure gauge should be set to coincide with the indicating pointer.

Table 3				
100FF		MIN.	MED.	MAX.
APPROX.	m <sup>3</sup> /h	2.8	3.1	3.5
GAS RATE	ft <sup>3</sup> /h	100	111	123
120FF		MIN.	MED.	MAX.
APPROX.	m <sup>3</sup> /h	3.5	3.9	4.2
GAS RATE	ft <sup>3</sup> /h	125	137	148

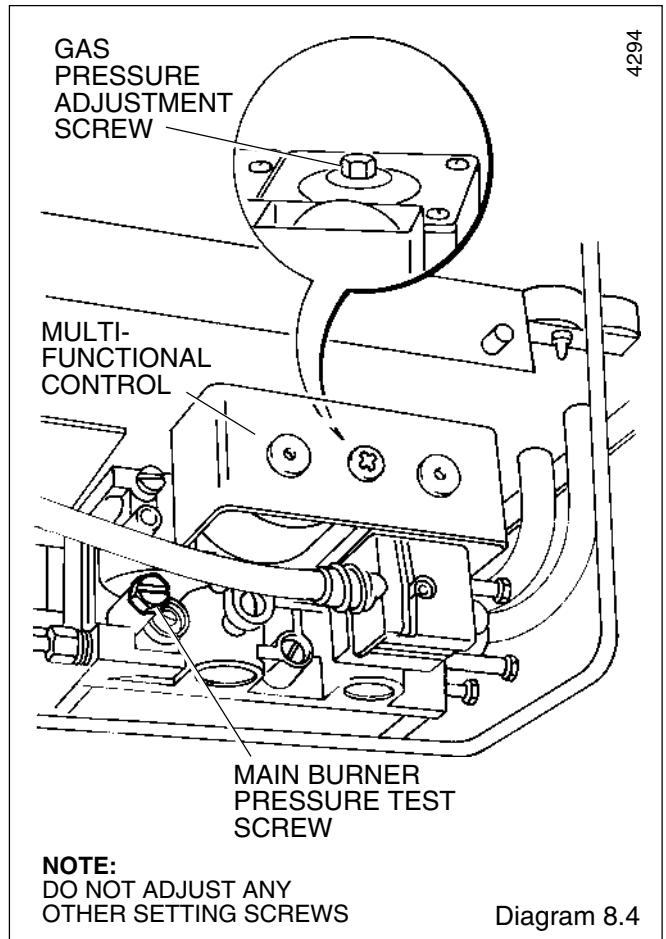

Diagram 8.4

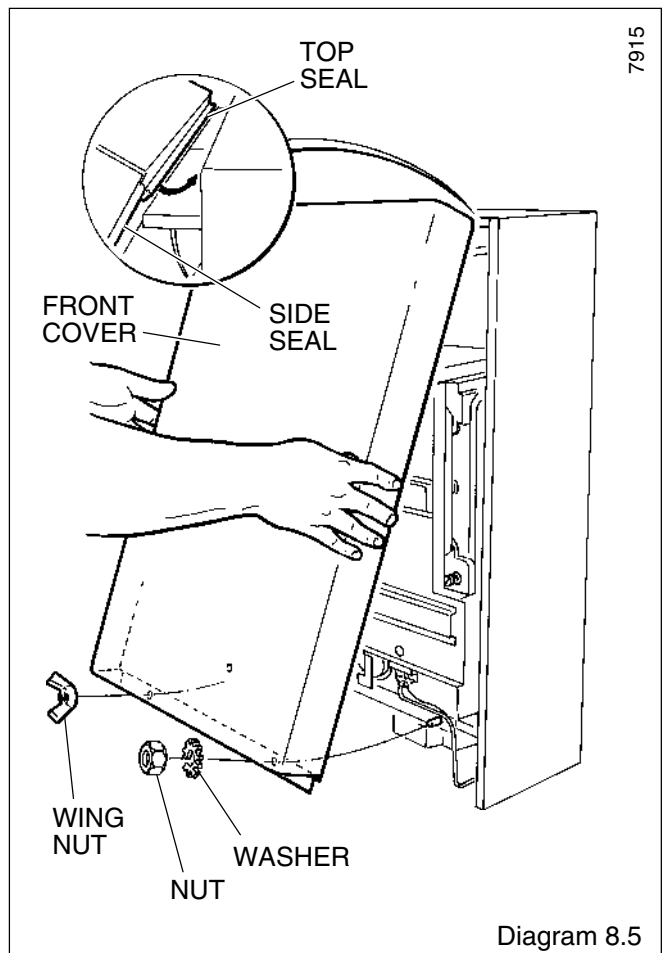

Diagram 8.5

## 8 Commissioning

### 8.9 Thermostatic Radiator Valves

If thermostatic radiator valves are fitted care must be taken to ensure that an adequate flow rate through the boiler when they close, refer to the current issue of BS7478 for guidance.

### 8.10 Operational Checks and Completion

Adjust the boiler temperature control and any system controls to their required settings. In addition it is necessary to complete the "Benchmark" logbook.

For IE, it is necessary to complete a "Declaration of Conformity" to indicate compliance to I.S.813. An example of this is given in the current edition of I.S.813.

Do not attempt to adjust the thermostat calibration screw.

Operate the boiler again on full service and check that the balancing is satisfactory, making adjustments as necessary.

Fit the front cover by hooking it under at the top and securing with the screws previously removed, see diagram 8.5.

Fit the controls cover by hooking into the sliders and pushing it back as far as it will go, see diagram 8.6.

**Testing Flue Gases:** If any doubt exists that the flue products are not exhausting correctly, investigate by use of a gas analyser (FGA).

### 8.11 Protection against Freezing

If the boiler is to be out of use for a period of time during severe weather conditions we recommended that the whole of the system, including the boiler, be drained off to avoid the risk of freezing up.

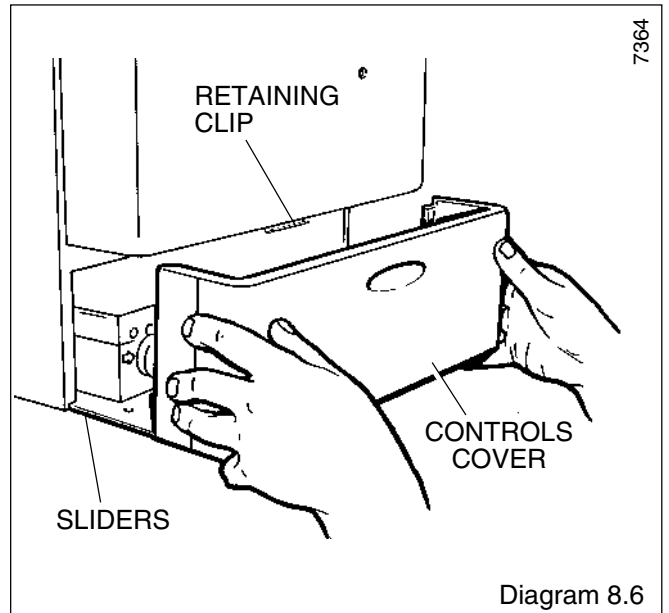

## 9 Instructions to the User

Instruct and demonstrate the safe and efficient operation of the boiler, heating system and domestic hot water system.

Advise the user, that to ensure the continued efficient and safe operation of the boiler it is recommended that it is checked and serviced at regular intervals. The frequency of servicing will depend upon the particular installation and usage, but in general once a year should be enough.

Draw attention, if applicable, to the current issue of the Gas Safety (Installation and Use) Regulations, Section 35, which imposes a duty of care on all persons who let out any property containing a gas appliance in the UK.

It is the Law that servicing is carried out by a **competent person**.

Advise the user of the precautions necessary to prevent damage to the system and the building in the event of the heating system being out of use during frost and freezing conditions.

Reminder - Leave these instructions and the "Benchmark" logbook with the user.

## 10 Servicing

**REMEMBER:** When replacing a part on this appliance, use only spare parts that you can be assured conform to the safety and performance specification that we require. Do not use reconditioned or copy parts that have not been clearly authorised by Glow-worm.

**NOTES:** To ensure the continued efficient and safe operation of the boiler it is recommended that it is checked and serviced as necessary at regular intervals. The frequency of servicing will depend upon the particular installation conditions and usage, but in general once a year should be enough.

It is the Law that any servicing is carried out by a **competent person**.

Before servicing turn off the gas and isolate the electrical supply to the boiler.

After completing a service always test for gas soundness and carry out functional check on controls.

Unless stated otherwise all parts are replaced in the reverse order to removal.

### 10.1 Access

Refer to diagram 8.6 and slide controls cover forward and off.

Remove the outer case, see diagram 8.5.

**NOTE:** As an aid to servicing the air pressure switch tube connections can be used to obtain a products of combustion reading.

Remove the RED tube from the connection on the air pressure switch and insert the analyser probe into the tube.

Switch on the electrical supply to operate the fan and turn on the gas supply.

On completion of the test switch off the electrical supply and the gas supply and reconnect the red tube to the air pressure switch.

### 10.2 Cleaning Heat Exchanger and Burner

Disconnect the air pressure tubes, see diagram 5.3.

Remove the blue and red electrical connections from the fan, see diagram 5.3.

Remove the fan taking care not to damage the gasket, see diagram 5.3.

Remove the flue hood, see diagram 5.4.

Remove the combustion chamber cover, see diagram 8.2.

Remove the cleaning plate from the combustion chamber cover, see diagram 8.2.

Disconnect the pilot pipe union connector and pilot burner, securing nut and shakeproof washer together with the pilot shield. Remove the pilot burner assembly taking care not to damage the electrode and lead assembly, see diagram 10.1.

Remove the securing screw from the burner support bracket, see diagram 10.2.

Remove the main burner from the main injector at the rear. Raise the burner up and forward, easing the pilot pipe down, to clear, take care not to damage the combustion chamber insulation or the pilot pipe.

Use a vacuum cleaner or suitable stiff brush to clean the burner thoroughly, making sure that all the burner ports are clear and unobstructed.

Place a sheet of paper in the base of the combustion chamber.

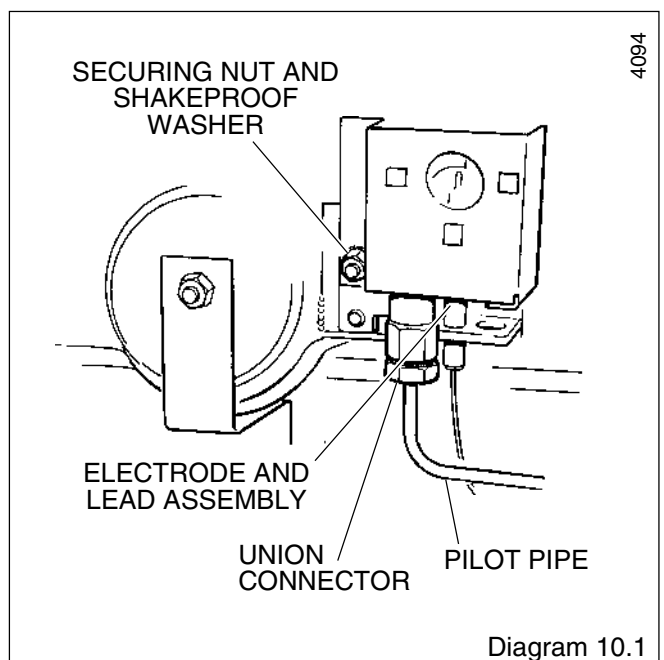

## 10 Servicing

### 100 FF ONLY

Remove the baffles, see diagram 10.3.

If a vertical or flue bend systems, using corrugated bends, see Flue Kit Installations, has been fitted then the TOP FLUE BAFFLES will have been REMOVED.

**NOTE:** When replacing the bottom three baffles, the two half and one whole baffle, make sure that they are positioned with the mark "100" to front of appliance as shown in diagram 10.3.

### 120 FF ONLY

Remove the baffles, see diagram 10.4.

**NOTE:** When replacing the bottom baffle, make sure that it is positioned with the word "Bottom" to front of appliance as shown in diagram 10.4.

### Continued-

The heat exchanger can now be cleaned, paying particular attention to the gap between the fins, with a suitably sized semi-stiff brush, using the cleaning plate, as shown in diagram 10.5, to protect the rear insulation panel.

Remove the paper together with any debris.

### 10.3 Main Injector

With the main burner removed the main injector can be inspected and cleaned as necessary, see diagram 10.6.

If removing for cleaning do not use a wire or sharp instrument on the hole.

Use a little suitable sealant on the external thread when refitting to make sure a gas tight seal is made.

**NOTE:** On refitting and after cleaning the heat exchanger make sure the burner is fitted correctly, that is, located on the main injector and horizontal.

### 10.4 Electrode, Pilot Burner and Pilot Injector

Clean the pilot burner and electrode.

100FF Model Only. To remove the electrode release the spring clip, see diagram 10.7.

120FF Model Only. To remove the electrode remove the securing screw, see diagram 10.7.

When removing and replacing the pilot injector from the pilot burner take care not to damage the electrode, see diagram 8.6, clean the injector by blowing through it.

Check that the spark gap is as shown in diagram 8.3.

### 10.5 Operational Checks

After completing a service and before fitting the case, check condition of the case seal and renew if necessary.

Examine the flue hood and terminal to make sure they are clean and clear of obstructions.

Light the boiler and carry out the functional checks as described in Section 8.

**Testing Flue Gases:** If any doubt exists that the flue products are not exhausting correctly, investigate by use of a gas analyser (FGA).

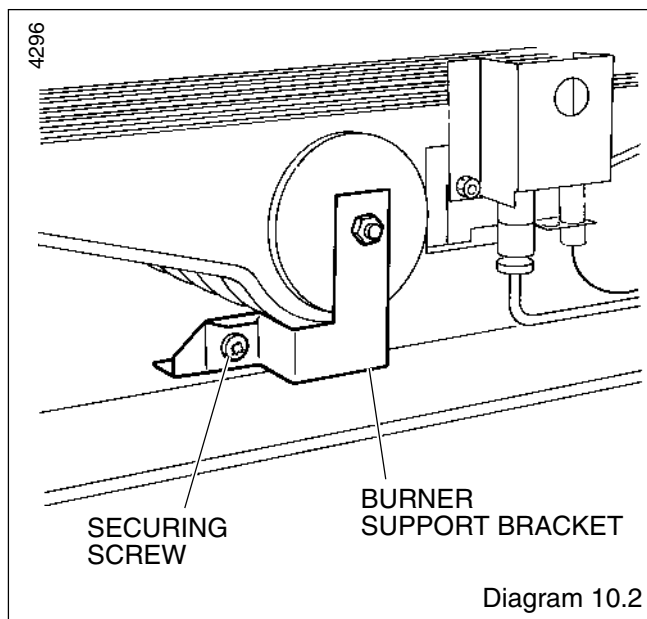
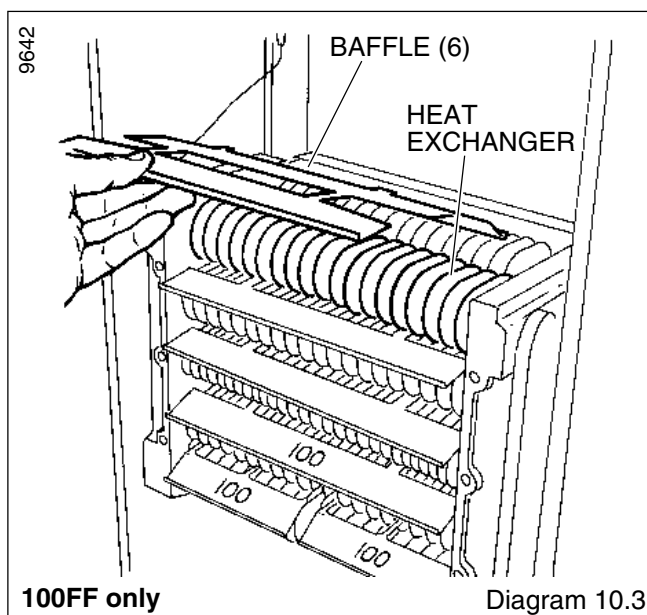
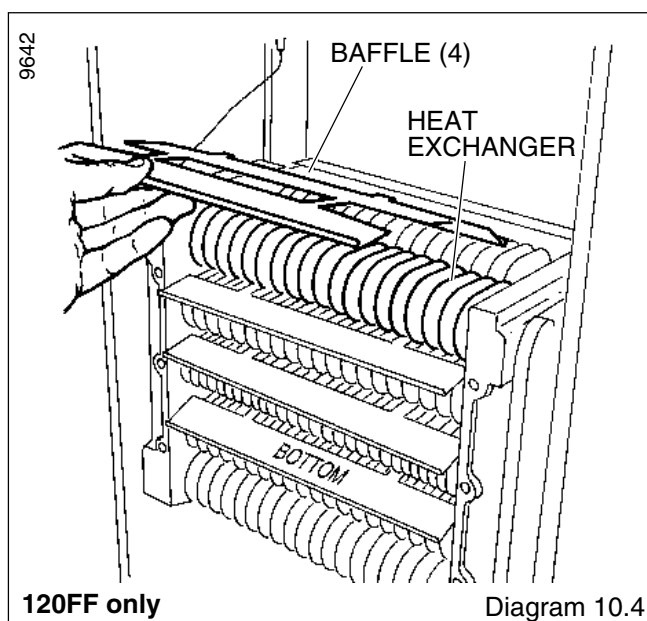

Diagram 10.2



100FF only

Diagram 10.3



120FF only

Diagram 10.4

## 10 Servicing

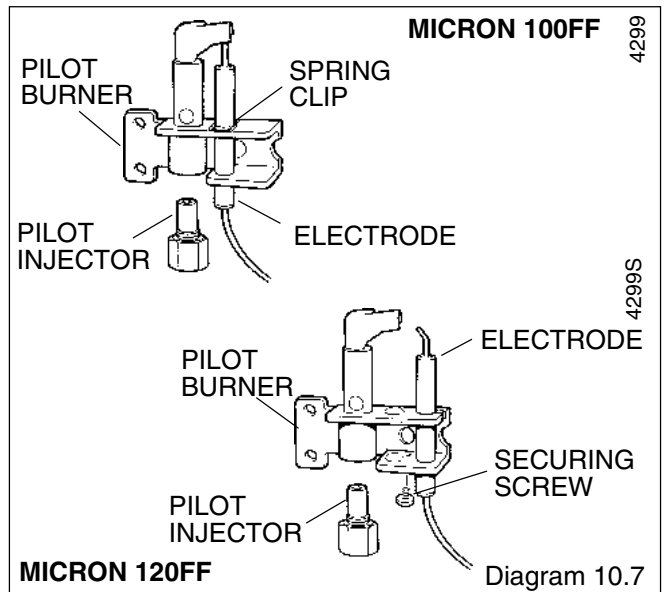
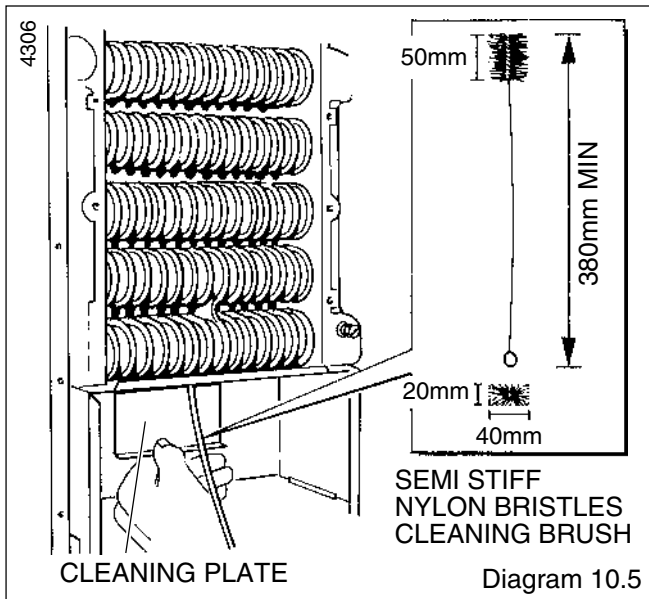
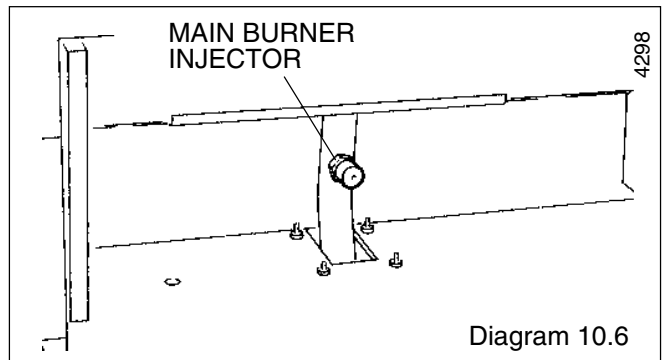

## 11 Fault Finding

### Neon Indicators - An Aid to Fault Finding

THE NEON INDICATORS ARE AN AID TO FAULT FINDING ONLY. FAILURE OF ANY OF THE NEON INDICATORS DOES NOT WARRANT THE REPLACEMENT OF AN OTHERWISE SATISFACTORY PRINTED CIRCUIT BOARD (PCB).

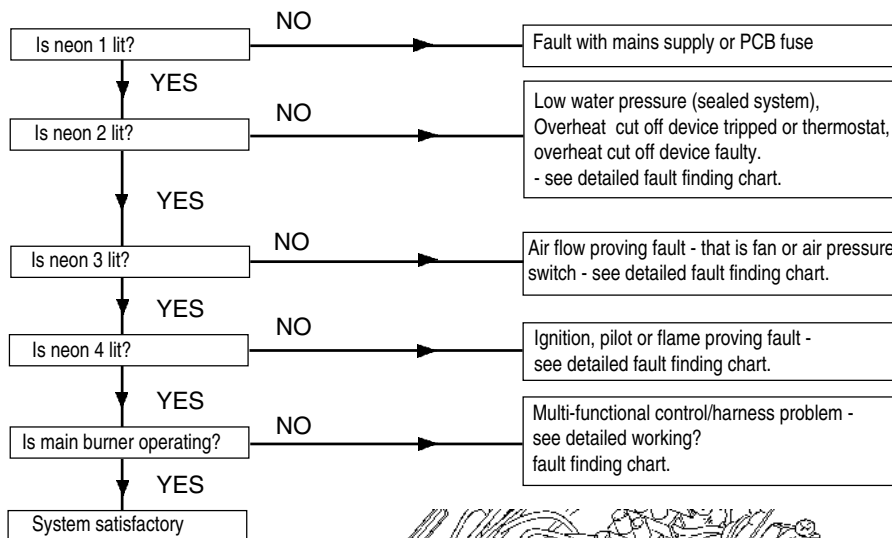

NEON INDICATORS

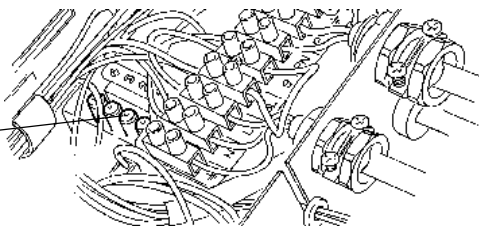

4120

Diagram 11.1

# 11 Fault Finding

## 11.1 Electrical

**IMPORTANT:** On completion of the Service/Fault Finding task which has required the breaking and remaking of the electrical connections, the earth continuity, polarity and short circuit and resistance to earth checks must be repeated using a suitable multimeter.

Refer to diagrams 11.1 to 11.5 for the relevant fault finding and wiring information.

Before detailed checking of electrical components ensure that remote controls are calling for heat. Check the gas supply is free of obstructions and purged of air. Check the overheat cutoff has not operated. For fully pumped systems only. Isolate the electrical supply and physically check ALL cables, connections and the printed circuit board fuse. Check the air tubes to the air pressure switch. Switch on the electrical supply and check for correct polarity. Turn the control thermostat to its maximum setting. Also check fuses.

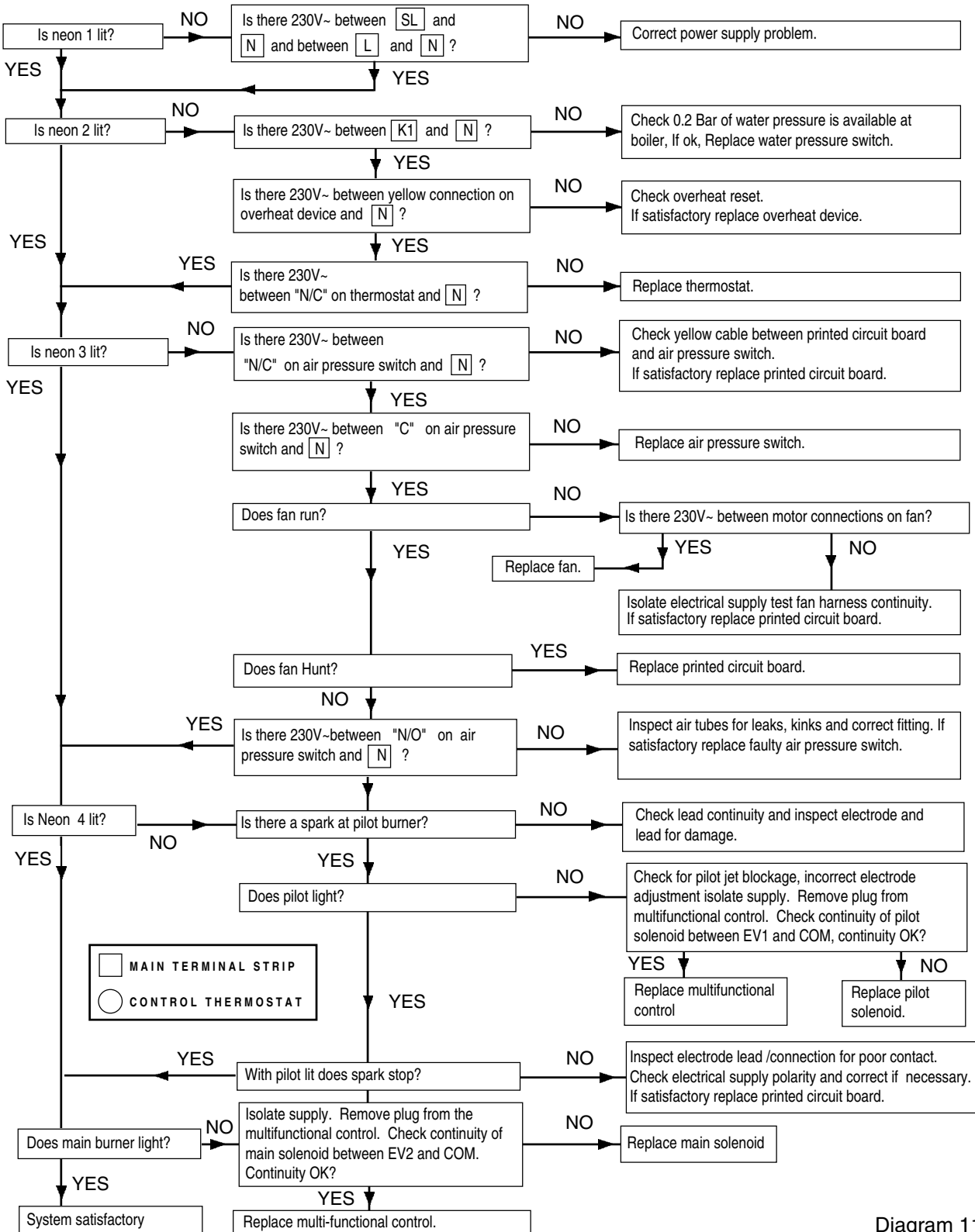

Diagram 11.2

# 11 Fault Finding

## 11.2 Electrical Supply Failure

Failure of the electrical supply will cause the burner to go out. Operation will normally resume on the restoration of the electrical supply. If the burner does not relight after an electrical failure the overheat device may need resetting.

Remove the control cover, see diagram 8.6 and push the reset button on the front of the control box, see diagram 8.1.

If the cutoff operates at any other time press the reset button and the burner should relight. If the fault persists refer to the fault finding chart.

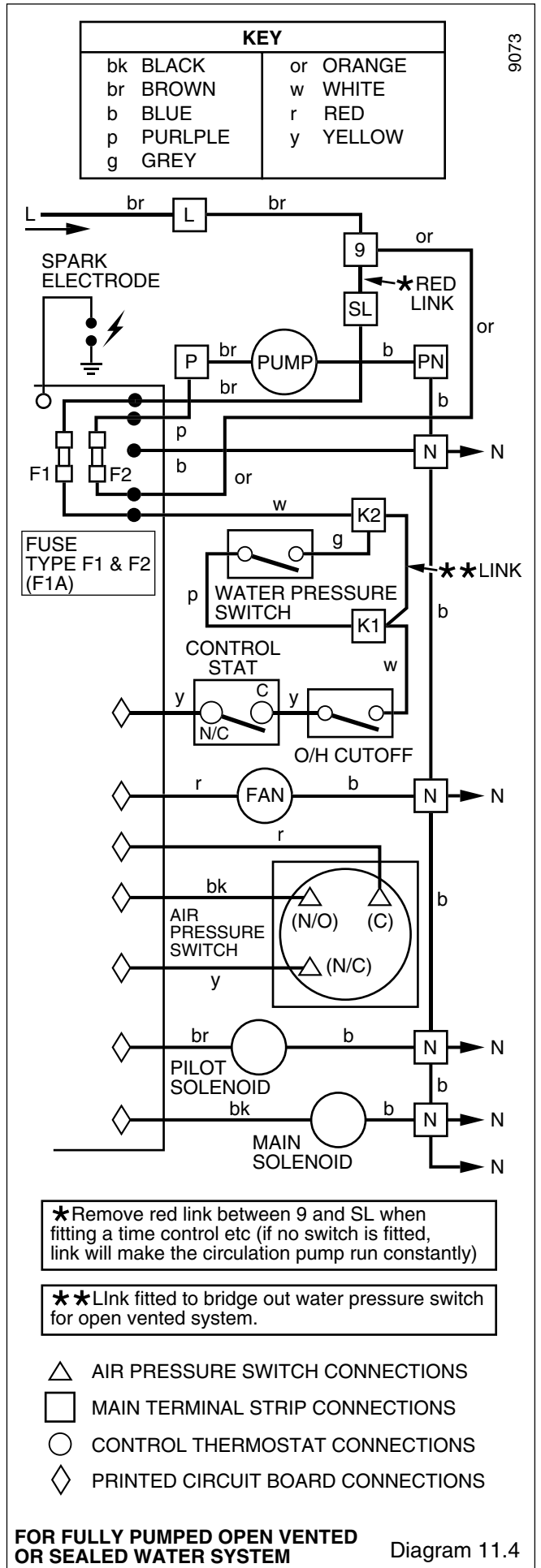
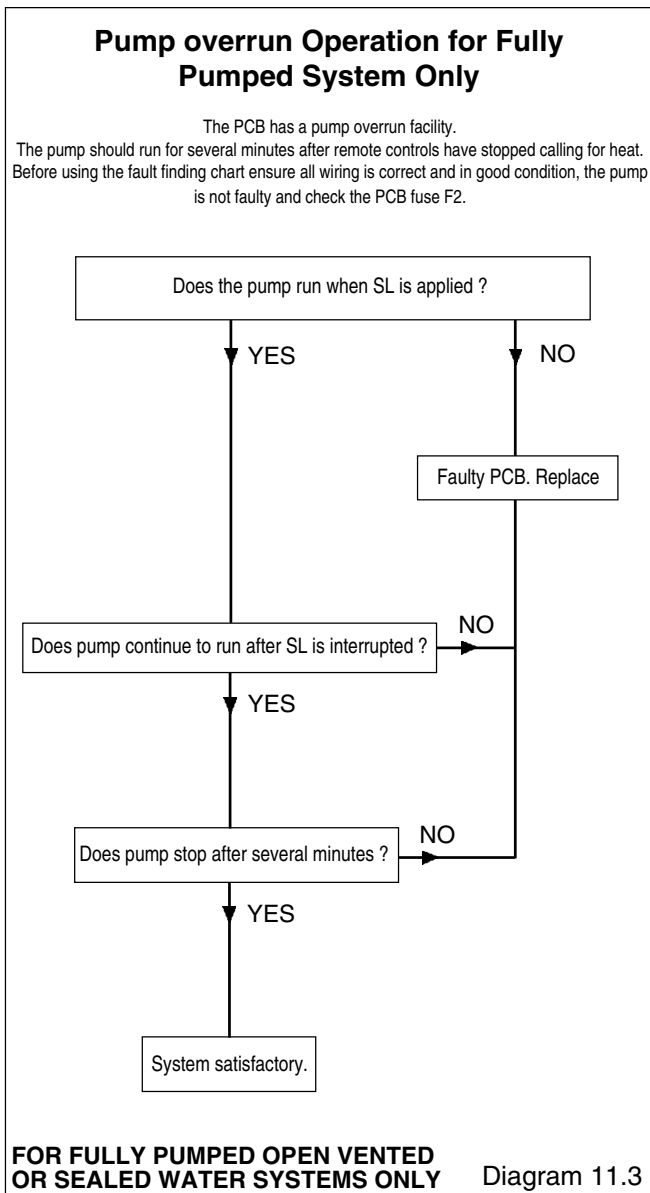

# 11 Fault Finding

9075

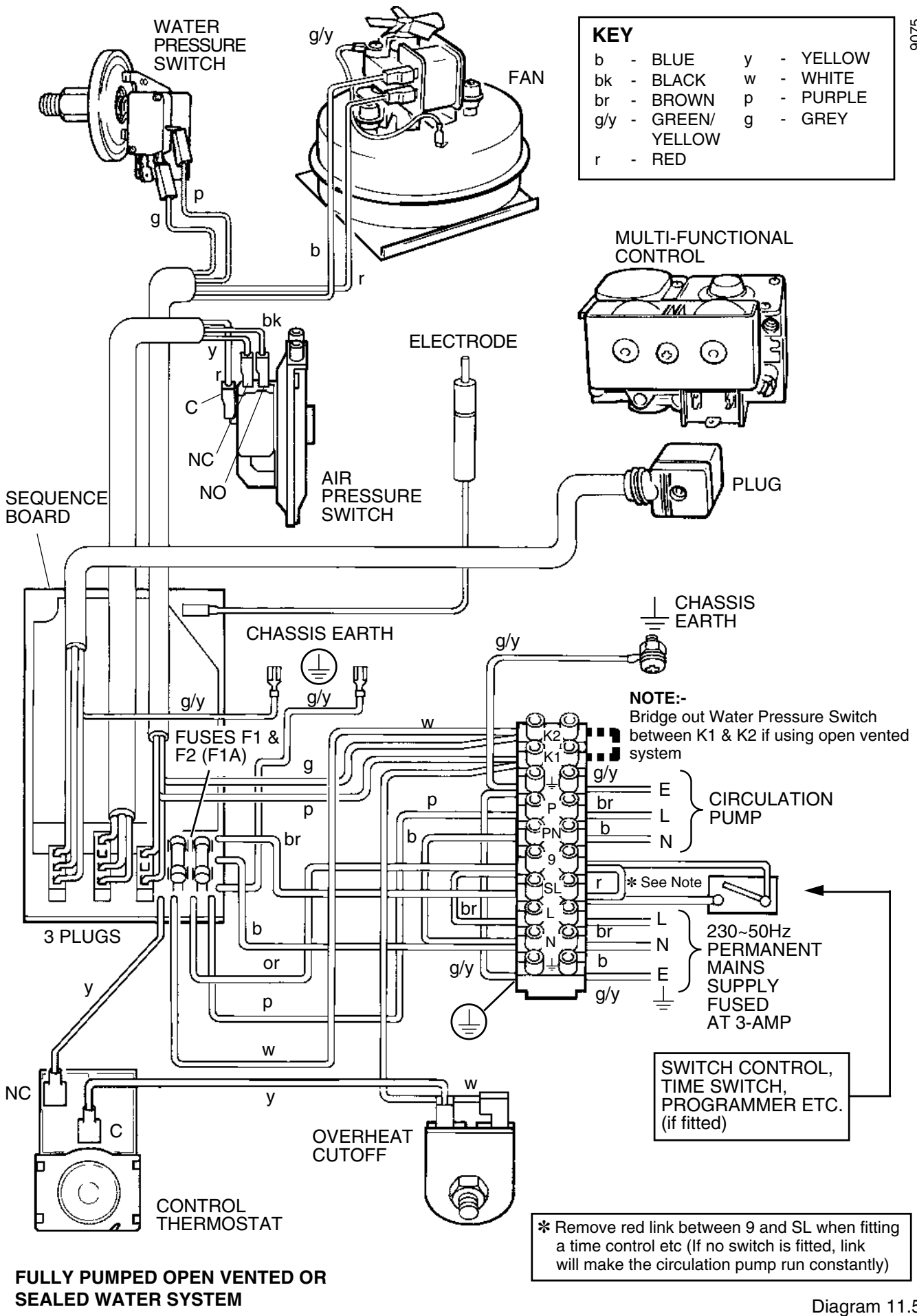

Diagram 11.5

## 12 Replacement of Parts

**NOTE:** Replacement of parts must only be carried out by a **competent person**.

Before replacing any parts isolate the boiler from the electrical supply and turn the gas supply off at the gas service cock, indicator slot to be vertical.

Unless stated otherwise, all parts are replaced in the reverse order to removal.

After assembly test for gas soundness and purge in accordance with the current issue of BS6891 or in IE, the current edition of I.S.813 "Domestic Gas Installations".

### 12.1 Access

Gain access as Section 10.1.

### 12.2 Control Thermostat - diagram 12.1 and 12.2

Remove and support the electrical control box, refer to Section 7.1.

Remove the control knob. Remove the electrical connections from the control thermostat body.

Release the control thermostat body by unscrewing the two screws and shakeproof washers in the front of the control box.

Remove the split pin and withdraw the thermostat phial from its pocket. Release the capillary from the base and the plastic retaining clip then remove it from the split grommet. Release the capillary from its clips. Remove the thermostat complete from the boiler.

Reassembly **NOTE:** When refitting the thermostat make sure that the thermostat phial is covered with heat sink compound then fully inserted into the phial pocket and that the capillary is within the gland seal, see diagram 12.2. Remake the electrical connections. There must be no kinks or sharp bends in the capillary.

### 12.3 Overheat Cutoff Device - diagram 12.1, 12.2 and 12.2A

Remove and support the electrical control box, refer to Section 7.1.

Remove the overheat cutoff electrical connections.

Disconnect the air pressure switch plug from the PCB.

Remove the locking nut from the overheat cutoff.

Release the capillary from the retaining clips then remove it from the split grommet.

Remove the split pin and then the phial.

When refitting use the heat sink compound supplied.

### 12.4 Control Board (PCB) - diagram 12.2A

Release the control box, refer to Section 7.1.

Disconnect the three electrical plugs and ignition lead.

Release the cables from the plastic retaining clip, then disconnect the cables from the PCB to the main terminal strip, control thermostat and earth connection.

Release the main terminal strip and plastic label.

Carefully pull the board away from its supports.

When refitting refer to wiring diagram 11.5.

### 12.5 Pilot Burner and Pilot Injector

Proceed as Section 10.2 and 10.4.

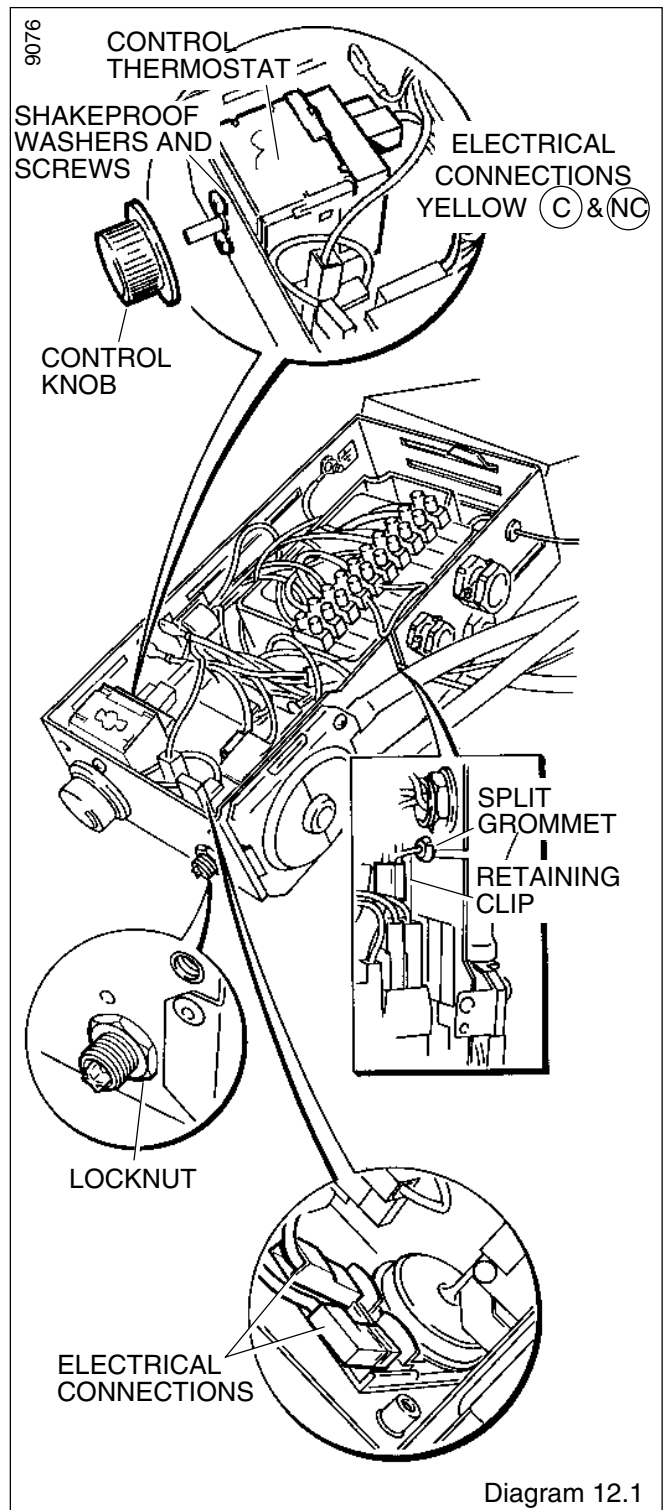

### 12.6 Electrode

Proceed as Section 8.3 and 8.5.

Gain access as Section 7 to remove lead from control box.

### 12.7 Multifunctional Control - diagram 10.3

Disconnect the pilot supply by unscrewing the tubing nut at the multifunctional control.

120FF ONLY. Take care as there is a restrictor in the pilot pipe.

Disconnect the electrical plug.

Support the multifunctional control, remove the four extended screws from the flanged connections at the left and right hand side.

## 12 Replacement of Parts

Remove and discard the original "O" rings from the flanged connection and fit the new "O" rings supplied, into recess, before fitting the replacement multifunctional control.

After assembly test for gas soundness and purge in accordance with the current issue of BS6891.

### 12.8 Solenoid - diagram 12.3

Remove the electrical plugs from the multifunctional control. Remove the securing screw and then the solenoid assembly.

### 12.9 Main Burner

Remove the main burner as Section 10.2.

### 12.10 Main Injector

Remove the main burner as Section 10.2.

Remove the main injector as Section 10.3.

### 12.11 Insulation - diagram 12.4

#### Combustion Chamber Front

Remove the retaining screw then the insulation.

#### Sides

Slide the insulation out.

### 12.12 Viewing Window - diagram 12.5

Remove the old self adhesive aluminium foil gasket and the old mica window. Replace with a new mica window. Peel off the backing paper and secure with new self adhesive aluminium foil gasket, see diagram 12.5. Ensure no air bubbles are trapped underneath the foil.

#### Important

Make sure that the mica window fully covers the opening and that the hole in the aluminium foil gasket is centred over opening.

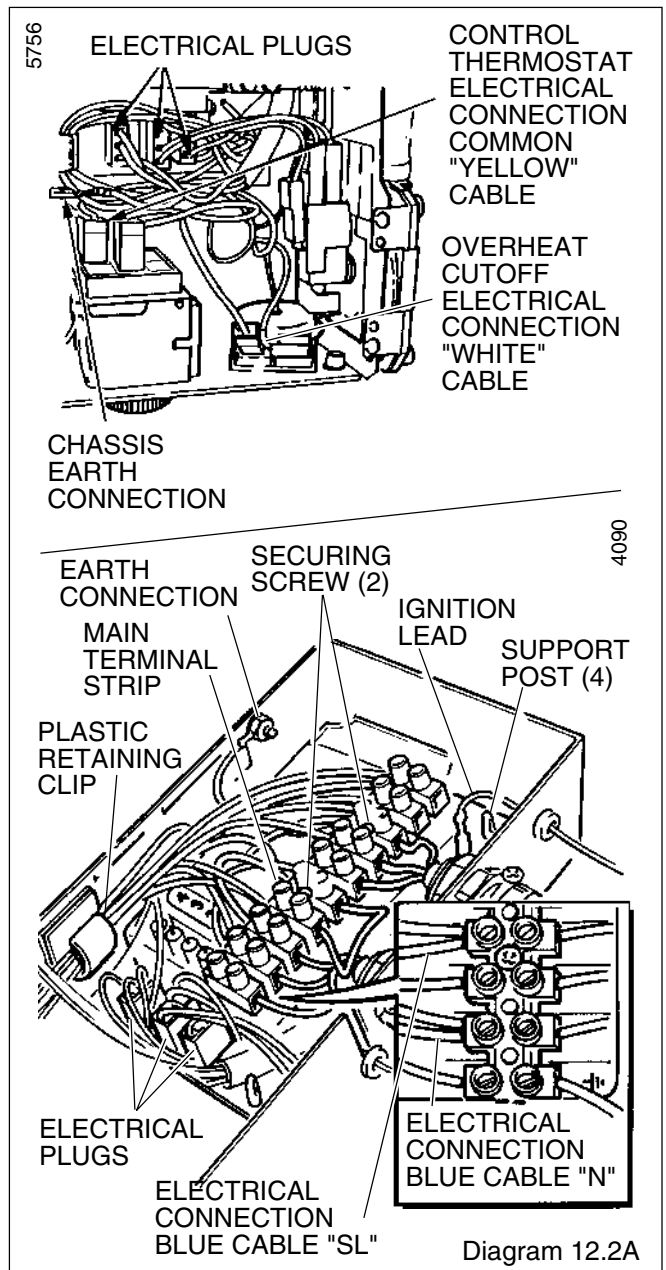
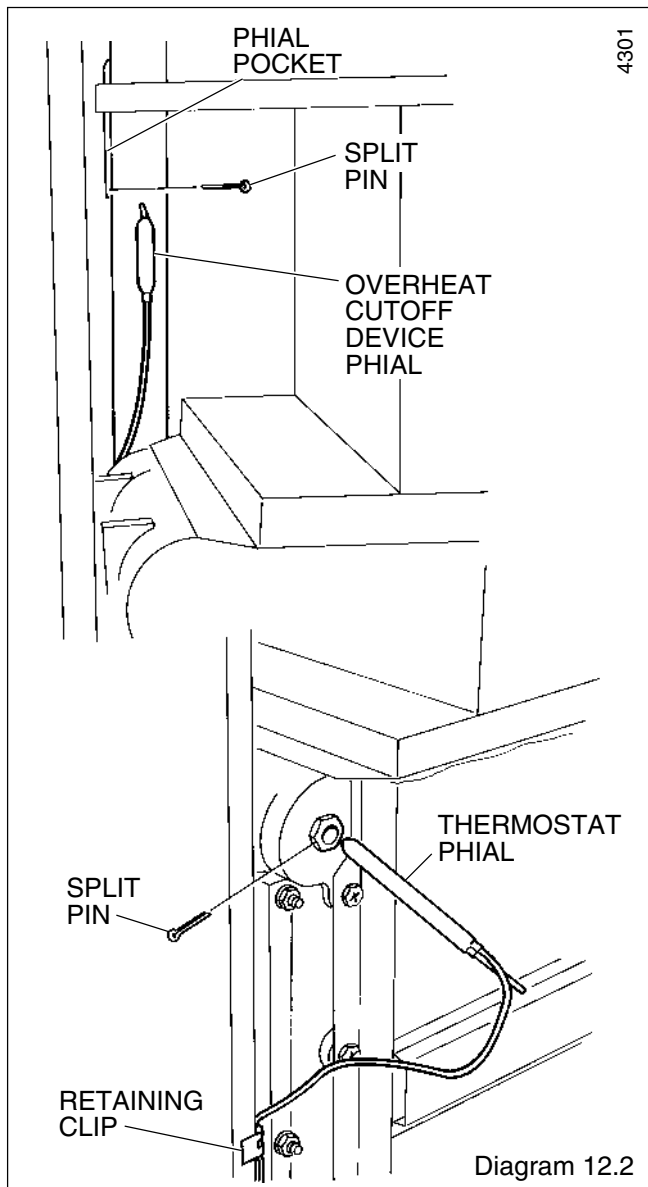

## 12 Replacement of Parts

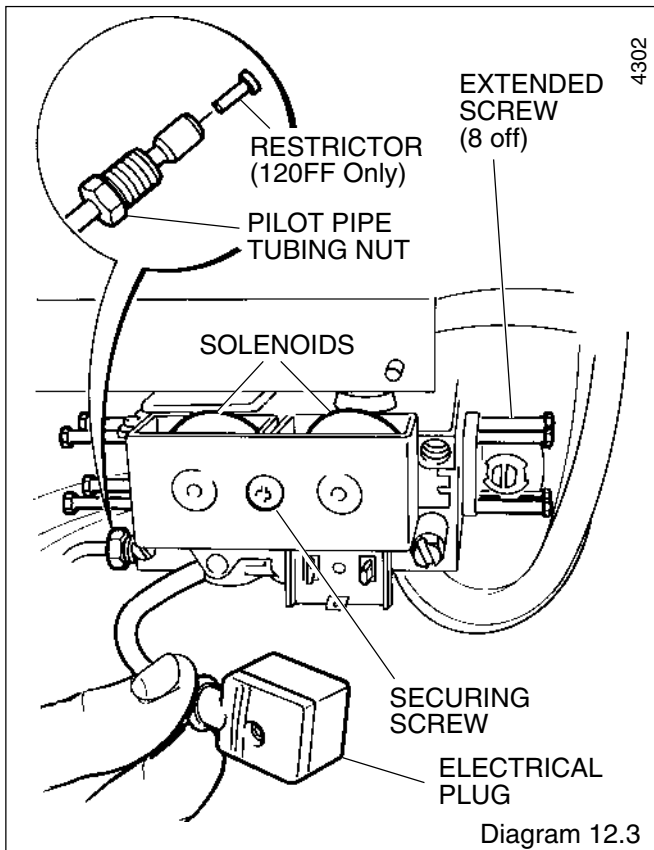

### 12.13 Air Pressure Switch - diagram 12.6

Release the control box as Section 7.1

Remove the pressure tubes and the electrical connections from the PCB, release the screws and remove the switch.

When fitting the replacement make sure that the plastic tubes and electrical connections are made as shown in diagram 11.5 and 12.6.

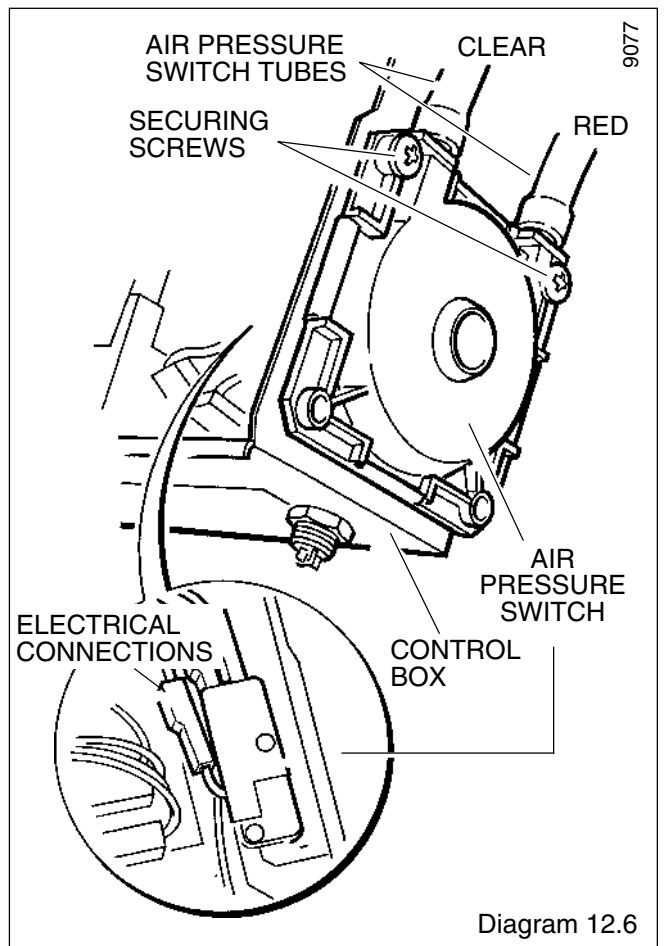
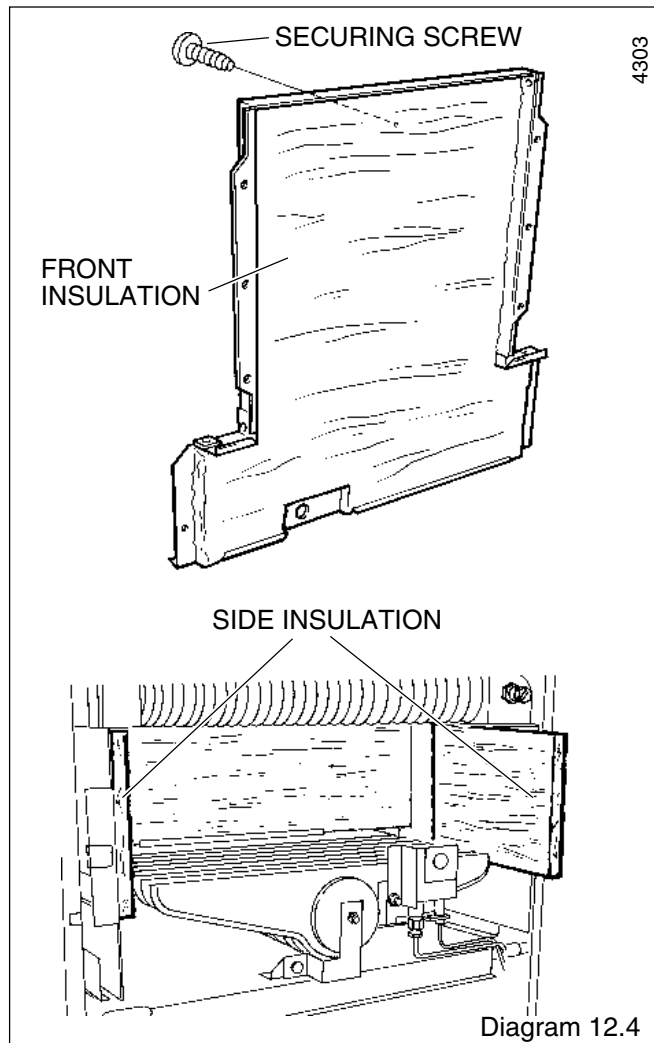
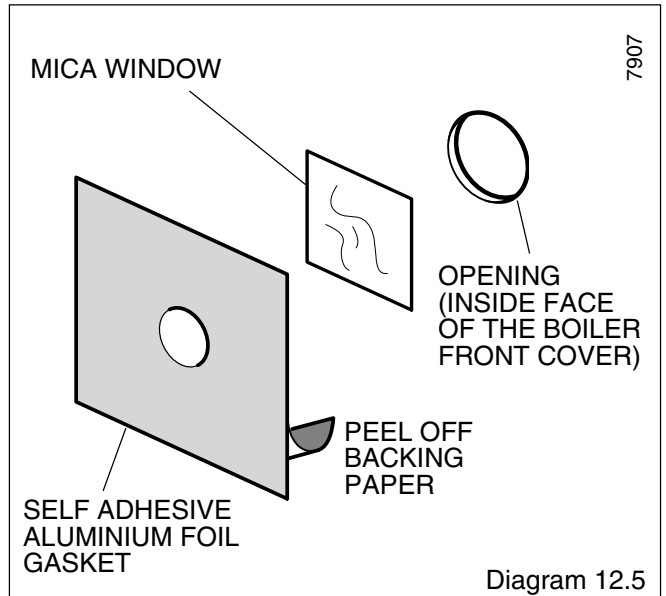

## 12 Replacement of Parts

### 12.14 Fan - diagram 5.3

Remove the electrical connections and disconnect the air pressure tubes.

Remove the fan assembly securing screws.

Make sure that the earth connection is remade onto the new fan assembly.

The polarity of the other connections is not important.

### 12.15 Water Pressure Switch - Sealed Water System Only

Release the water pressure and drain, refer to Section 3.

Disconnect the electrical connections at the microswitch, see diagram 12.7.

Remove pressure switch.

On assembly, use new "O" ring, secure the water pressure switch with locknut in the orientation shown as diagram 12.7.

Make up water loss and pressurise system, refer to "Commissioning".

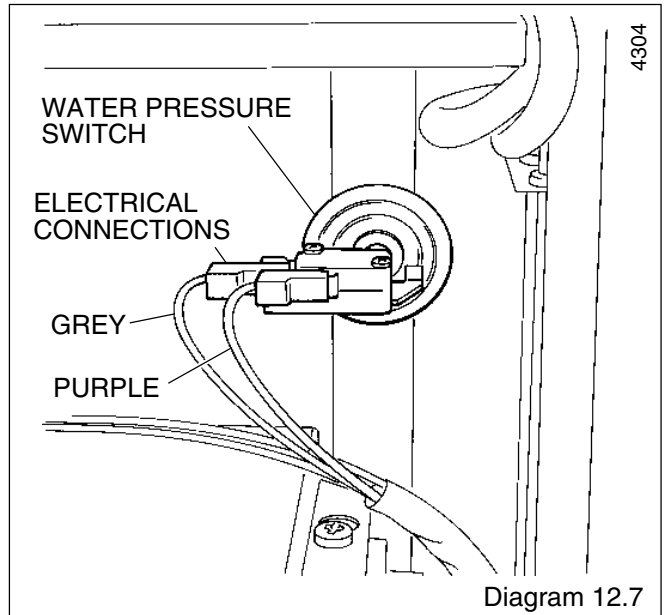

## 13 Spare Parts

### 13.1 Part Identification

The key number in the diagram and the first column of the list will help to identify the spare part.

### 13.2 Ordering

When ordering any spare part, please quote the part number and the description from the list together with the model name and serial number information from the data label. The data label is positioned at the bottom right hand side of case.

If ordering from British Gas also quote the GC number of the appliance from the data label and the GC number of the spare part, from the list.

Ref	Part No	Description	Location	GC Part No
1	800442	Multifunctional control	Diagram 12.3	278 021
2	08040	"O" ring	Diagram 12.3	334 592
3	205727	Injector - 100FF	Diagram 10.6	278 197
3a	205726	Injector - 120FF	Diagram 10.6	278 196
4	203432	Pilot burner - 100FF	Diagram 10.7	278 023
4a	203434	Pilot burner - 120FF	Diagram 10.7	E00 998
5	2000801236	Mica Window and Gasket	Diagram 12.5	
6	2000800529	Fan assembly - 100FF	Diagram 5.3	278 194
6a	2000800532	Fan assembly - 120FF	Diagram 5.3	278 185
7	202626	Spark electrode and lead - 100FF	Diagram 10.7	313 998
7a	202629	Spark electrode and lead - 120FF	Diagram 10.7	278 238
8	K3580	Clip - electrode	Diagram 10.7	390 983
9	800850	Thermostat - control	Diagram 12.1	*** **
10	202232	Air pressure switch - 100FF	Diagram 12.6	278 239
10a	202201	Air pressure switch - 120FF	Diagram 12.6	313 992
11	800275	Control knob	Diagram 12.1	313 609
12	2000800656	Water pressure switch	Diagram 12.7	*** **
13	204212	"O" ring	Diagram 12.7	281 343
14	202015	Fuse	Diagram 11.5	334 750
15	900847	Control board PCB (not illustrated)	Diagram 12.2A	*** **
16	800272	Overheat safety cutoff	Diagram 12.2A	313 606

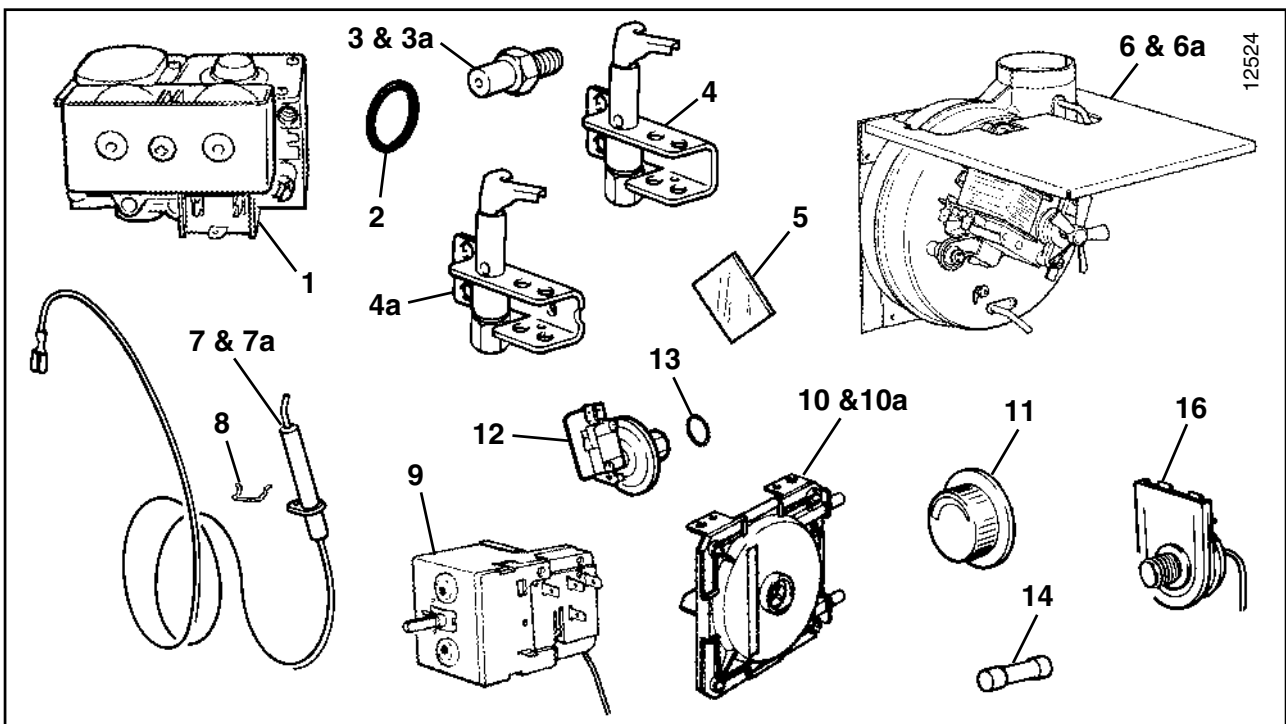

*Because of our constant endeavour for improvement, details may vary slightly from those shown in these instructions.*