



Glow-worm

Installation and main- tenance instructions

MicraCom

24c-AS/1

28c-AS/1



GB, IE

Contents

1	Safety	3	9.7	Checking the heating mode	30
1.1	Intended use	3	9.8	Checking the domestic hot water generation	30
1.2	Qualification	3	9.9	Checking leak-tightness	30
1.3	General safety information	3	9.10	Thoroughly flushing the heating installation ("hot")	30
1.4	Regulations (directives, laws, standards)	5	10	Adapting the unit to the installation	30
1.5	List of relevant standards for Great Britain and Ireland	5	10.1	Adapting the heating settings	30
2	Guarantee and Customer Service	6	11	Handing over to the end user	32
3	Technical data	7	12	Inspection and maintenance	33
4	Notes on the documentation	9	12.1	Complete Service Interval Record section	33
5	Product description	9	12.2	Checking and setting the CO ₂ content	33
5.1	CE marking	9	12.3	Moving the expansion vessel to the maintenance position on the combustion block	34
5.2	Serial number	9	12.4	Moving the expansion vessel to the maintenance position on the hydraulic block	34
5.3	Data plate	9	12.5	Cleaning/checking the components	34
5.4	Product design	10	12.6	Draining the product	39
5.5	Safety Devices	10	12.7	Completing inspection and maintenance work	39
6	Set-up	11	13	Troubleshooting	39
6.1	Checking the scope of delivery	11	13.1	Querying the fault memory	39
6.2	Product dimensions	11	13.2	Eliminating faults	39
6.3	Installation site	11	13.3	Resetting parameters to factory settings	39
6.4	Minimum clearances	11	13.4	Replacing defective components	39
6.5	Air/flue pipe	12	14	Decommissioning	41
6.6	Using the mounting template	16	14.1	Temporary decommissioning	41
6.7	Wall-mounting the product	17	14.2	Permanently decommissioning	41
6.8	Removing/installing the front casing	17	15	Recycling and disposal	41
7	Installation	18	Appendix	42	
7.1	Requirements	18	A	Inspection and maintenance work	42
7.2	Flushing the heating installation for the first time ("cold")	19	B	Diagnostics codes	42
7.3	Connecting gas and water	19	C	Status codes	45
7.4	Connecting the condensate discharge hose	19	D	Fault codes	46
7.5	Condensate discharge systems	19	E	Check programmes	50
7.6	Connecting the drain pipework for the expansion relief valve	21	F	Wiring diagram	51
7.7	Filling the condensate siphon	21	G	Commissioning Checklist	52
7.8	Air/flue system	21	H	Commissioning Flow Chart	56
7.9	Electrical installation	22	Index	57	
8	Operation	25			
8.1	Calling up the installer level	25			
8.2	Using diagnostics codes	25			
8.3	Running check programmes	25			
8.4	Calling up status codes	25			
8.5	Exiting the installer level	25			
9	Start-up	26			
9.1	Carrying out the initial start-up	26			
9.2	Checking and treating the heating water/filling and supplementary water	26			
9.3	Filling the heating installation	27			
9.4	Purging the heating installation	27			
9.5	Filling and purging the domestic hot water system	27			
9.6	Check and gas setting	27			

1 Safety

1.1 Intended use

The product is intended as a heat generator for open heating installations and for domestic hot water generation.

Improper use of any kind is prohibited.

Intended use also includes the following:

- use of the product only in mobile homes that are made, transported once and permanently situated in Great Britain and Ireland. After the transportation of the mobile home to its destination the complete product must be checked for leak-tightness again
- validity of the product only for Great Britain and Ireland and for the gas types in Great Britain and Ireland as listed on the data plate
- Installing and operating the product only in conjunction with accessories for the air/flue pipe which are listed in the other applicable documents and comply with the type of unit
- Using the product while observing the accompanying operating, installation and maintenance instructions for the product along with all other components of the installation
- Installing and setting up the product while observing the product and system approval
- Observing all inspection and maintenance conditions listed in the instructions
- Installing while observing the IP code

The following is classed as improper use:

- Using the product in vehicles, such as mobile homes or caravans. Units that are not classed as vehicles are those that are installed in a fixed and permanent location (known as "fixed installation").
- Any direct use in industrial or commercial processes
- Any use other than those described in these instructions and any use that goes beyond what is described here

1.2 Qualification

The person carrying out the work described here must have completed professional training. The competent person must demonstrably have all of the knowledge, skills and capabilities that are required in order to carry out the work mentioned below.

The following work must only be carried out by competent persons who are sufficiently qualified to do so:

- Set-up
- Dismantling
- Installation
- Start-up
- Inspection and maintenance
- Repair
- Decommissioning
- ▶ Proceed in accordance with current technology.
- ▶ Use the correct tool.

The above-mentioned work must always only be carried out by persons with sufficient qualifications.

This product can be used by children over eight years old and also by persons with limited physical, sensory or mental capabilities or insufficient experience and/or knowledge if they are supervised or have been provided with instructions on how to safely use the product, and they understand the risks resulting from using the product. Children must not play with the product. Cleaning and user maintenance work must not be carried out by children unless they are supervised.

1.3 General safety information

The following sections convey important safety information. It is essential to read and observe this information in order to prevent risk of death, risk of injury, material damage or environmental damage.

1.3.1 Risk of death from escaping gas

What to do if you smell gas in the building:

- ▶ Avoid rooms that smell of gas.
- ▶ If possible, open doors and windows fully and ensure adequate ventilation.

1 Safety

- ▶ Do not use naked flames (e.g. lighters, matches).
- ▶ Do not smoke.
- ▶ Do not use any electrical switches, mains plugs, doorbells, telephones or other communication systems in the building.
- ▶ If it is safe to do so, close the emergency control valve or the main isolator.
- ▶ If possible, close the gas stopcock on the product.
- ▶ Warn other occupants in the building by yelling or banging on doors or walls.
- ▶ Leave the building immediately and ensure that others do not enter the building.
- ▶ Notify the gas supply company or the Emergency Service Provider +44 (0) 800 111999 by telephone once you are outside of the building.

1.3.2 Flue gas

Flue gases may cause poisoning, while hot flue gases may also cause burns. Flue gases must therefore never be allowed to escape uncontrollably.

What to do if you smell flue gas in the property:

- ▶ Open all accessible doors and windows fully to provide ventilation.
- ▶ Decommission the product.
- ▶ Check the flue gas routes in the product and the flue gas diversions.

To prevent flue gas exit:

- ▶ Only operate the product if the air/flue pipe has been completely installed.
- ▶ With the exception of short periods for testing purposes, only operate the product when the front casing is installed and closed.
- ▶ In order to operate the product, ensure that the condensate siphon is always full.
 - Water seal level for B23 or B23P unit types with condensate siphon (third-party accessory): ≥ 200 mm

To ensure that the seals are not damaged:

- ▶ Instead of grease, use only water or commercially available soft soap to aid installation.

1.3.3 Air supply

Unsuitable or insufficient combustion and room air may lead to material damage, but also to life-threatening situations.

To ensure that the combustion air supply is sufficient during open-flued operation:

- ▶ Ensure that the air supply to the product's installation room is permanently unobstructed and sufficient in accordance with the relevant ventilation requirements. This also applies, in particular, for cupboard installations.

To prevent corrosion on the product and in the flue system:

- ▶ Ensure that the combustion air supply is free from sprays, solvents, chlorinated cleaning agents, paint, adhesives, ammonia compounds, dust or similar substances.
- ▶ Ensure that no chemical substances are stored at the installation site.
- ▶ If you are installing the product in hairdressing salons, painter's or joiner's workshops, cleaning businesses or similar locations, choose a separate installation room in which the room air is technically free of chemical substances.

1.3.4 Electricity

The power supply terminals L and N remain live.

To prevent electric shocks, proceed as follows before working on the product:

- ▶ Disconnect the product from the power supply by switching off all power supplies at all poles (electrical partition with a contact gap of at least 3 mm, e.g. fuse or circuit breaker) or remove the mains plug (if present).
- ▶ Secure against being switched back on again.
- ▶ Wait at least three minutes until the condensers have discharged.
- ▶ Check that there is no voltage.

1.3.5 Weight

To prevent injuries when transporting the product:

- ▶ Make sure that the product is transported by at least two people.

1.3.6 Explosive and flammable substances

To prevent explosions and fire:

- ▶ Do not use the product in storage rooms that contain explosive or flammable substances (such as petrol, paper or paint).

1.3.7 High temperatures

To prevent burns:

- ▶ Only carry out work on components once they have cooled down.

To prevent material damage that is caused by heat transfer:

- ▶ Only solder connectors if the connectors are not yet screwed to the service valves.

1.3.8 Heating water

Both unsuitable heating water and air in the heating water may cause material damage to the product and in the heat generator circuit.

- ▶ Check the quality of the heating water. (→ Page 26)
- ▶ If you use non-diffusion-tight plastic pipes in the heating installation, ensure that no air gets into the heat generator circuit.

1.3.9 Neutralisation device

To prevent contamination of the waste water:

- ▶ Check whether a neutralising unit must be installed in accordance with national regulations.
- ▶ Observe local regulations on neutralising condensate.

1.3.10 Frost

To prevent material damage:

- ▶ Do not install the product in rooms prone to frost.

1.3.11 Safety devices

- ▶ Install the necessary safety devices in the installation.

1.4 Regulations (directives, laws, standards)

- ▶ Observe the national regulations, standards, directives, ordinances and laws.

1.5 List of relevant standards for Great Britain and Ireland

- ▶ Observe the national regulations, standards, directives, ordinances and laws.



You can find a list of relevant standards at:
<https://www.glow-worm.co.uk/standards>

Guarantee Registration

Thank you for installing a new Glow-worm appliance in your home.

Glow-worm appliances are manufactured to the very highest standard so we are pleased to offer our customers a comprehensive guarantee.

To maintain your guarantee, the boiler must be serviced annually by a competent person who holds the required qualifications in accordance with the rules in force of the country where the product is installed and in accordance with the manufactures recommendations.

We recommend you complete your guarantee registration as soon as possible.

Sales Support:

Telephone: 0345 602 0262

Technical Enquiries:

Telephone: 01773 828300

Email: technical@glow-worm.co.uk

General Enquiries:

Telephone: 01773 828100

Training Enquiries:

Telephone: 0345 601 8885

Email: training.enquiries@vaillant-group.com

Spares Enquiries:

Telephone: 01773 881383

To register your Glow-worm appliance visit:

<https://self-service.glow-worm.co.uk/warranty-registration>



Glow-worm is a licensed member of the Benchmark Scheme. Benchmark places responsibilities on both manufacturers and installers. The purpose is to ensure that customers are provided with the correct equipment for their needs, that it is installed, commissioned and serviced in accordance with the manufacturer's instructions by a competent person approved at the time by the Health and Safety Executive and that it meets the requirements of the appropriate Building Regulations.

The Benchmark Checklist can be used to demonstrate compliance with Building Regulations and should be provided to the customer for future reference.

Installers are required to carry out installation, commissioning and servicing work in accordance with the Benchmark Code of Practice which is available from the Heating and Hotwater Industry Council who manage and promote the Scheme.

Benchmark is managed and promoted by the Heating and Hotwater Industry Council.



3 Technical data

Technical data – General

	24c-AS/1	28c-AS/1
Designated country (designation in accordance with ISO 3166)	GB, IE	GB, IE
Permissible gas categories	I12H3P	I12H3P
CE number	0063CU3005	0063CU3005
ErP	92 %	93 %
Product-side gas connection	1/2"	1/2"
Product-side flow/return heating connections	3/4"	3/4"
Expansion relief valve connection pipe (min.)	15 mm	15 mm
Condensate discharge hose (min.)	14.2 mm	14.2 mm
Gas connection pressure, G20 natural gas	2.0 kPa (20.0 mbar)	2.0 kPa (20.0 mbar)
Gas connection pressure, liquefied petroleum gas G31	3.7 kPa (37.0 mbar)	3.7 kPa (37.0 mbar)
Maximum flue gas temperature	89 °C	89 °C
Min. gas volume flow at 15 °C and 1013 mbar, G20	0.66 m³/h	0.76 m³/h
Min. gas volume flow at 15 °C and 1013 mbar, G31	0.65 kg/h	0.56 kg/h
Max. gas volume flow at 15 °C and 1013 mbar (based on heating mode), G20	1.99 m³/h	2.59 m³/h
Max. gas volume flow at 15 °C and 1013 mbar (based on heating mode), G31	1.47 kg/h	1.91 kg/h
Max. gas volume flow at 15 °C and 1013 mbar (based on domestic hot water generation), G20	2.54 m³/h	2.96 m³/h
Max. gas volume flow at 15 °C and 1013 mbar (based on domestic hot water generation), G31	1.86 kg/h	2.18 kg/h
Permissible installation types	C13, C33, C43, C53	C13, C33, C43, C53
Nominal efficiency in partial load mode (30%)	107.8 %	108.2 %
NOx class	6	6
Nitrogen oxide emissions, NOx weighted (Hs) (G20)	27.11 mg/kW-h	32.40 mg/kW-h
CO emissions	137.2 ppm	121.7 ppm
Net weight	25.6 kg	26.5 kg

Technical data – Power/load (G20)

	24c-AS/1	28c-AS/1
Nominal heat output range P at 50/30 °C	6.6 to 20.0 kW	7.7 to 25.9 kW
Nominal heat output range P at 60/40 °C	6.4 to 19.3 kW	7.5 to 25.1 kW
Nominal heat output range P at 75/55 °C	6.0 to 18.3 kW	6.9 to 23.9 kW
Max. heat input for domestic hot water (Qmax) (Hi)	24.0 kW	28.0 kW
Flue gas mass flow rate in heating mode at P min.	3.2 g/s	3.7 g/s
Flue gas mass flow rate in heating mode at P max.	8.9 g/s	11.6 g/s
Nominal heat input range for heating	6.2 to 18.8 kW	7.2 to 24.5 kW

Technical data – Power/load (G31)

	24c-AS/1	28c-AS/1
Nominal heat output range P at 50/30 °C	9.0 to 20.0 kW	7.7 to 25.9 kW
Nominal heat output range P at 75/55 °C	8.1 to 18.3 kW	6.9 to 23.9 kW
Max. heat input for domestic hot water (Qmax)	24.0 kW	28.0 kW
Flue gas mass flow rate in heating mode at P min.	4.0 g/s	3.4 g/s
Flue gas mass flow rate in heating mode at P max.	9.1 g/s	11.8 g/s
Nominal heat input range for heating	8.4 to 18.8 kW	7.2 to 24.5 kW

3 Technical data

Technical data – Heating

	24c-AS/1	28c-AS/1
Maximum heating flow temperature (factory setting – D.71)	75 °C	75 °C
Maximum flow temperature adjustment range	30 to 75 °C	30 to 75 °C
Maximum operating pressure (MWP)	0.3 MPa (3.0 bar)	0.3 MPa (3.0 bar)
Nominal water flow ($\Delta T = 20$ K)	788 l/h	1,029 l/h
Approximate value for the condensate volume during nominal load operation (pH value between 3.5 and 4.0) at 50/30 °C	1.89 l/h	2.46 l/h
Remaining pump head (at nominal circulation water volume)	0.027 MPa (0.270 bar)	0.017 MPa (0.170 bar)
Contents of the heating expansion vessel	8 l	8 l

Technical data – Domestic hot water

	24c-AS/1	28c-AS/1
Minimum water flow	1.7 l/min	1.7 l/min
Specific flow rate D ($\Delta T = 30$ K)	11.5 l/min	13.4 l/min
Specific flow rate D ($\Delta T = 35$ K)	9.9 l/min	11.5 l/min
Permissible operating pressure	0.03 to 1 MPa (0.30 to 10 bar)	0.03 to 1 MPa (0.30 to 10 bar)
Recommended supply pressure	0.3 MPa (3.0 bar)	0.3 MPa (3.0 bar)
Hot water comfort in accordance with the standard EN 13203	**	**
Flow rate limiter for cold water	8.0 l/min	10.0 l/min
Domestic hot water output temperature range	35 to 55 °C	35 to 55 °C

Technical data – Electrics

	24c-AS/1	28c-AS/1
Electrical connection	230 V/50 Hz	230 V/50 Hz
Permissible connected voltage	195 to 253 V	195 to 253 V
Built-in fuse (slow-blow)	T2/2 A, 250 V	T2/2 A, 250 V
Maximum electrical power consumption	90 W	90 W
Standby electrical power consumption	1.7 W	1.7 W
IP rating	IPX5	IPX5

4 Notes on the documentation

- ▶ Always observe all the operating and installation instructions included with the system components.
- ▶ Pass these instructions and all other applicable documents on to the end user.

These instructions apply only to:

Product article number

	Article number	Gas Council Number
MicraCom 24c-AS/1 (H-GB)	0010026136	47-019-58
MicraCom 28c-AS/1 (H-GB)	0010026137	47-019-59

5 Product description

This product is a gas-fired wall-hung condensing boiler.

5.1 CE marking



The CE marking shows that the products comply with the basic requirements of the applicable directives as stated on the declaration of conformity.

The declaration of conformity can be viewed at the manufacturer's site.

5.2 Serial number

You can find the serial number on the data plate and on the sticker on the upper side of the product.

The serial number and the product designation can also be found on a sticker under the product's front casing.

5.3 Data plate

The data plate is mounted on the rear of the electronics box and on the upper side of the product at the factory. Any information that is not listed here can be found in separate sections.

Information	Meaning
	Read the instructions.
... 24c-AS/1, 28c-AS/1 ...	Marketing name
ES, IT, etc.	Target market
Cat.	Approved gas category
Type	Products of the category
2H, 2HS, 2ELw... - G20, G31... - XX mbar (X.X kPa)	Gas group and gas connection pressure as set at the factory
T _{max}	Maximum flow temperature
PMS	Permissible operating pressure, heating mode
NOx class	NOx class (nitrogen oxide emissions)
D	Specific flow rate
V	Mains voltage

Information	Meaning
Hz	Mains frequency
W	Maximum electrical power consumption
IP	IP rating
Code (DSN)	Product code
PMW	Permissible operating pressure for domestic hot water mode
	Heating mode
Q _n	Heat input range
P _n	Nominal heat output range (75/55 °C)
P _{nc}	Condensing nominal heat output range (50/30 °C)
	DHW mode
P _{nw}	Maximum heat output in domestic hot water generation mode
Q _{nw}	Maximum heat input in domestic hot water generation mode
Hi	Lower gross calorific value
	Barcode with serial number 3rd to 6th digits = production date (year/week) 7th to 16th digit = product article number
GC no.	Gas council number



Note

Make absolutely sure that the product is compatible with the gas group at the installation site.

5 Product description

5.4 Product design

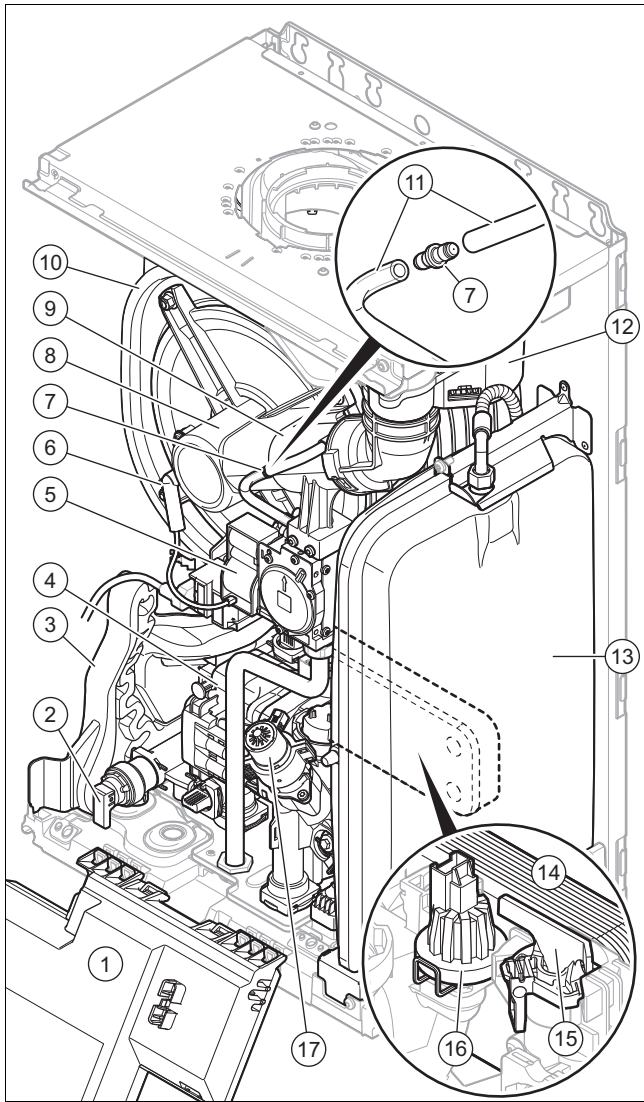

1	Electronics box	10	Heat exchanger
2	Expansion relief valve for heating	11	Reference pressure pipe for the gas valve assembly
3	Condensate siphon	12	Fan
4	Pump	13	Expansion vessel
5	Gas valve assembly	14	Domestic hot water plate heat exchanger
6	Ignition and flame control electrode	15	Domestic hot water volume flow sensor
7	Restrictor for the reference pressure pipe	16	Pressure sensor
8	Burner	17	Prioritising diverter valve
9	Venturi		

5.5 Safety Devices

5.5.1 Electrical Supply Failure

The boiler will not work without an electrical supply. Normal operation of the boiler should resume when the electrical supply is restored.

Reset any external controls, to resume normal operation of the central heating.

If the boiler does not resume normal operation reset the boiler. If the boiler does not resume normal operation after this call your Installation/ Servicing company or **Glow worm** service.

5.5.2 Overheating Safety

The boiler software is designed to recognise the potential for an overheat lockout and will shutdown before this happens.

To restart the boiler, press the button  more than 3s.

If the boiler fails to resume normal operation and all external controls are calling for heat, then call your Installation/ Servicing company or **Glow worm** service.

5.5.3 Frost protection

The appliance has a built in frost protection device that protects the boiler from freezing. With the gas and electric supplies ON and irrespective of any room thermostat setting, the frost protection device will operate the pump when the temperature of the boiler water falls below 8°C.

A timer is used so that the temperature can be checked periodically. After 10 minutes the pump will be stopped if the temperature is higher than 10°C or has already reached 35°C. The burner will activate if the boiler temperature does not reach 10°C after 30 minutes or at any time if the temperature drops to 5°C.

The burner will switch off when the temperature reaches 35°C.

5.5.4 Condensate Drain Blockage

During freezing conditions the condensate drain can become blocked, this may be due to the forming of ice in the condensate drain external to the house. Release an ice blockage by the use of warm cloths on the pipe.

6 Set-up

6.1 Checking the scope of delivery

Quantity	Designation
1	Gas-fired wall-hung boiler
1	Bag containing valves for gas, heating and domestic hot water
1	Drain spigot of the expansion relief valve
2	Bag with small parts
1	Condensate discharge hose
1	Enclosed documentation

6.2 Product dimensions

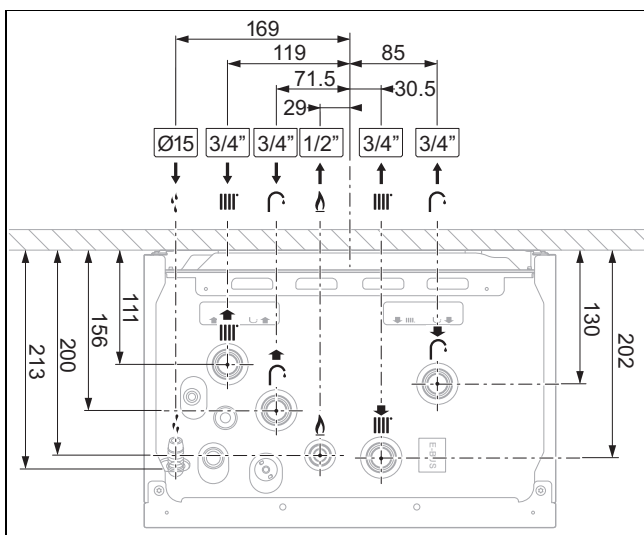
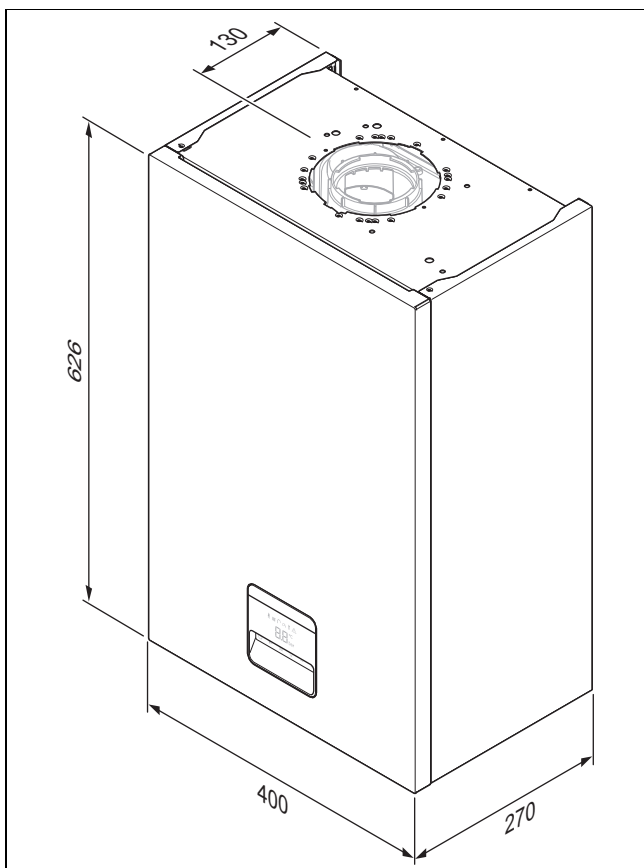

6.3 Installation site

If the boiler is to be installed in a timber frame building it should be fitted in accordance with the current version of the Institute of Gas Engineers document IGE/UP/7. If in doubt seek advice from local gas undertaking or the manufacturer.

6.4 Minimum clearances

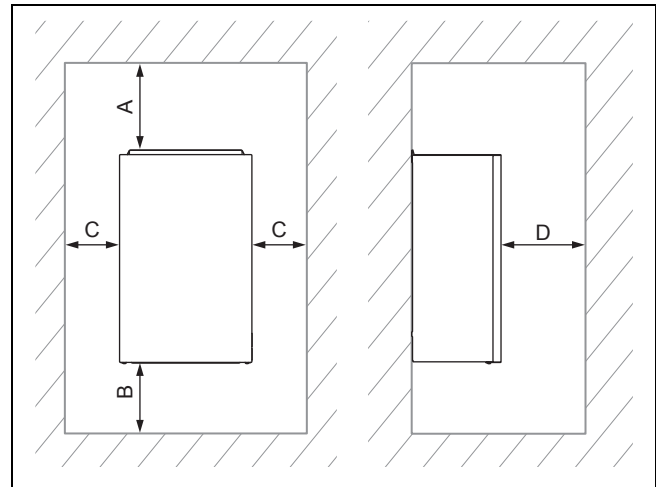

Minimum clearance	
A	60/100 mm diameter air/flue pipe: 150 mm 80/125 mm diameter air/flue pipe: 276 mm
B	180 mm
C	5 mm
D	500 mm (This clearance can be reduced to 5 mm if the product is installed behind a removable plate or a door)

The boiler and flue are suitable for installation onto and through combustible materials provided that:

1. Minimum 5 mm clearance is maintained around the circumference of the flue (air intake).
2. The combustible surface and fixings are suitable for supporting the load.
3. The minimum clearances from the boiler case are maintained.

6.4.1 Compartment Ventilation

The boilers are very high efficiency appliances.

As a consequence the heat loss from the appliance casing during operation is very low.

Compartment ventilation is not required as the products are only certified, and can only be fitted with a concentric flue system.

6 Set-up

6.5 Air/flue pipe

6.5.1 Regulation

Different flue outlet configurations can be carried out.

- Consult the installation manual for air/flue gas systems for more information about the other possibilities and associated accessories.

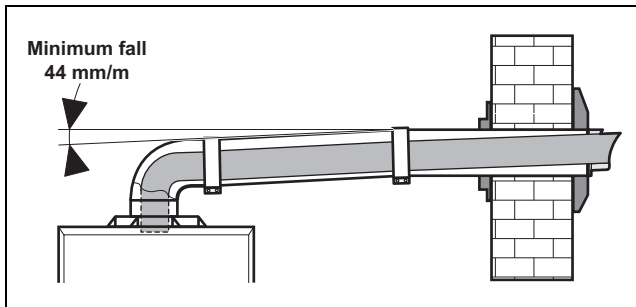

- Standard flue terminal kits have an in-built fall back to the boiler to drain the condensate. These can be fitted level between the appliance and the termination position. All other extended flues must have a fall of at least 44 mm/m.

The maximum length of the flue outlet is defined according to its type (for example C13).

- Whatever the kind of flue system chosen, observe the minimum distances to position the flue terminals.
- To install the flue, refer to the separate flue instruction supplied with your appliance.
- Explain these requirements to the user of the appliance.

In GB the minimum acceptable siting dimensions for the terminal from obstructions, other terminals and ventilation openings are shown in diagram overleaf.

In IE the minimum distances for flue terminal positioning must be those detailed in I.S. 813 "Domestic Gas Installations".

The terminal must be exposed to the external air, allowing free passage of air across it at all times.

Being a condensing boiler some plumbing may occur from the flue outlet. This should be taken into consideration when selecting the position for the terminal.

6.5.2 Position of the air/flue terminal

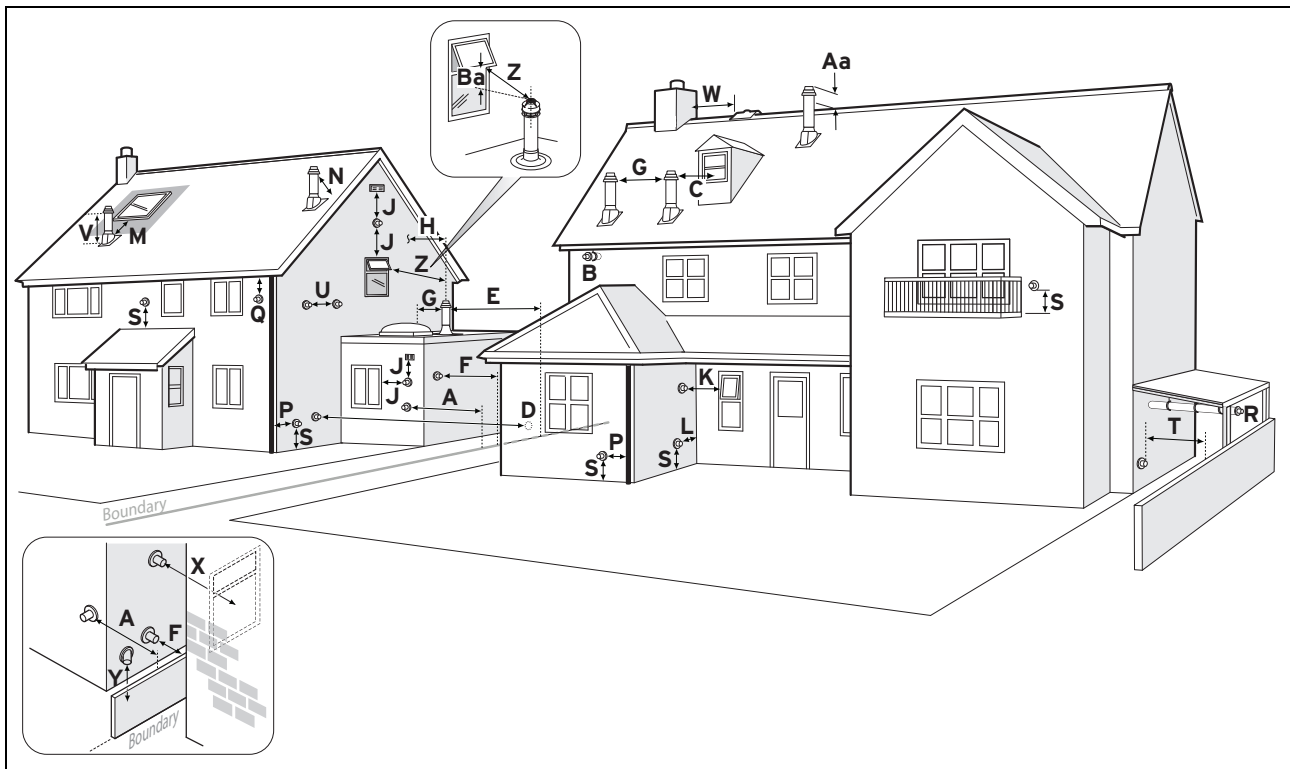

6.5.2.1 Positioning the terminal of a fan-supported flue system

	Installation site	Dimensions
A	Adjacent to a boundary.	300 mm
B ¹⁾	The dimension below eaves, balconies and car ports can be reduced to this value, as long as the flue terminal is extended to clear any overhang. External flue joints must be sealed with a suitable silicon sealant.	25 mm
C	Between a vertical flue terminal and a window or dormer window on a roof.	1,500 mm
D	Between terminals facing each other.	1,200 mm
E	Vertical flue clearance, adjacent to a boundary line.	300 mm
F ²⁾	Distance to a boundary line, unless it will cause a nuisance. BS 5440:Part 1 recommends that care is taken when siting terminal in relation to boundary lines.	600 mm
G	Minimum clearance from a skylight to a vertical flue or to another vertical flue.	Min. 300 mm
H	Vertical flue clearance, to noncombustible building material. Vertical flue clearance to combustible building material.	500 mm 1,500 mm
J	Above, below and either side of an opening door, air vent or opening window.	300 mm
K	Diagonally to an opening door, air vent or opening window.	600 mm
L ²⁾	To an internal or external corner.	200 mm
M	Below a Velux window. Above or to either side of the Velux window.	2,000 mm 600 mm
N	From a pitched roof. In regions with heavy snowfall.	400 mm 500 mm
P	From vertical drain pipes and soil pipes.	25 mm
	<p>1) There should be no ventilation/opening in the eaves within 300 mm distance of the terminal.</p> <p>2) These dimensions comply with the building regulations, but they may need to be increased to avoid wall staining and nuisance from plumbing depending on site conditions.</p> <ul style="list-style-type: none"> – Terminals must be positioned so to avoid combustion products entering the building. – Support the flue at approximately one metre intervals and at a change of direction, use suitable brackets and fixings. – Installations in car ports are not recommended. – The flue cannot be lower than 1 metre from the top of a lightwell due to the build up of combustion products. – Dimensions from a flue terminal to a fanned air inlet to be determined by the ventilation equipment. 	

6 Set-up

	Installation site	Dimensions
Q	Below eaves. Below gutters, pipe and drains.	200 mm 75 mm
R	The dimension below eaves, balconies and car ports can be reduced to this value, as long as the flue terminal is extended to clear any overhang. External flue joints must be sealed with suitable silicon sealant.	25 mm
S	Above adjacent ground or balcony.	300 mm
T ²⁾	Distance to a surface facing a terminal, unless it will cause a nuisance. BS 5440: Part 1 recommends that care is taken when siting terminals in relation to surfaces facing a terminal.	600 mm
U	Clearance alongside another terminal.	300 mm
V	Above roof level.	300 mm
W	Minimum to vertical structure on roof, roof vent.	Min. 300 mm
X	Minimum to opening in adjacent building.	Min. 2000 mm
Y	Minimum at an angle to a boundary which is not less than 300 mm to the terminal	Min. 600 mm
Z	Minimum measured to the nearest corner of the OPEN window	Min. 600 mm
Aa	No more than this value above ridge.	Max. 300 mm
Ba	Not less than this value below the opening window	Min. 300 mm
	1) There should be no ventilation/opening in the eaves within 300 mm distance of the terminal. 2) These dimensions comply with the building regulations, but they may need to be increased to avoid wall staining and nuisance from plumbing depending on site conditions. <ul style="list-style-type: none"> - Terminals must be positioned so to avoid combustion products entering the building. - Support the flue at approximately one metre intervals and at a change of direction, use suitable brackets and fixings. - Installations in car ports are not recommended. - The flue cannot be lower than 1 metre from the top of a lightwell due to the build up of combustion products. - Dimensions from a flue terminal to a fanned air inlet to be determined by the ventilation equipment. 	

6.5.2.2 Horizontal terminal positioning

BS 5440-1 recommends that fanned flue chimney terminals should be positioned as follows:

- a) at least 2 m from an opening in the building directly opposite, and
- b) so that the products of combustion are not directed to discharge directly across a boundary if the products are likely to cause a nuisance to a neighbour or discharge over a walkway or patio.

For IE see current issue of IS 813.

For boilers covered within this manual.

Dimensions B and R:

These clearances may be reduced to 25 mm without affecting the performance of the boiler. In order to ensure that the condensate plume does not affect adjacent surfaces the terminal should be extended as shown below.

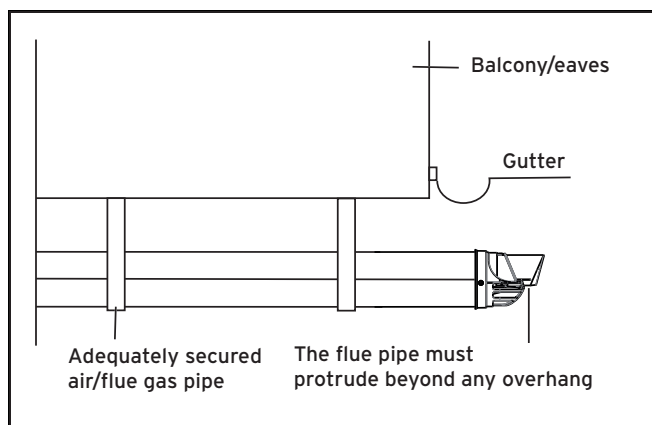

You can use a plume management kit to enable the termination point to be positioned and directed away from the building fabric.

6.5.3 Flue Configuration Description

6.5.3.1 Horizontal Concentric Flue \varnothing 60/100 mm or \varnothing 80/125 mm (C13 type installation)

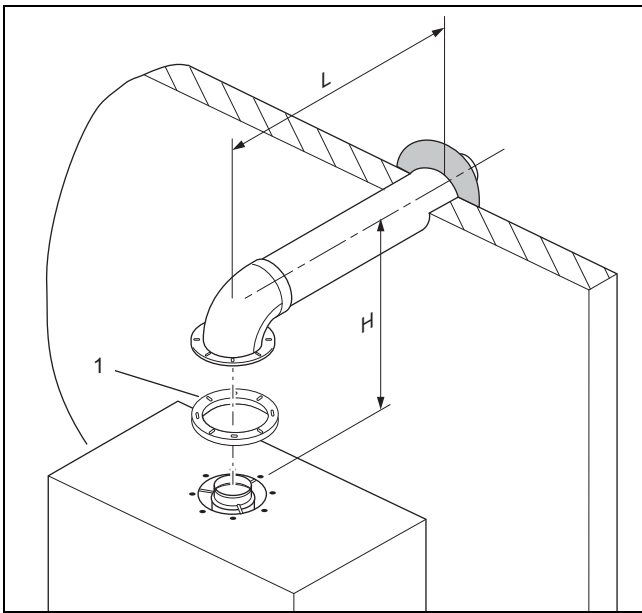

1 Gasket (fitted)



Note

If the terminal is at less than 1.80 m from the ground, you must install a terminal protection kit.

Each time an additional 90° bend is necessary (or 2 at 45°), the length (L) must be reduced (see table below).

\varnothing 60/100	24c-AS/1	28c-AS/1
Min. length (L)	0.3 m including 1 elbow	0.3 m including 1 elbow
Max. length (L)	9 m including 1 elbow	9 m including 1 elbow
Max. height (H)	0.63 m	0.63 m
Equivalence to 1 elbow 90°	1 m	1 m
Equivalence to 1 elbow 45°	0.5 m	0.5 m

\varnothing 80/125	24c-AS/1	28c-AS/1
Min. length (L)	0.3 m including 1 elbow	0.3 m including 1 elbow
Max. length (L)	16 m including 1 elbow	20 m including 1 elbow
Max. height (H)	2.10 m	2.10 m
Equivalence to 1 elbow 90°	2.5 m	2.5 m
Equivalence to 1 elbow 45°	1 m	1 m

6.5.3.2 Terminal protection

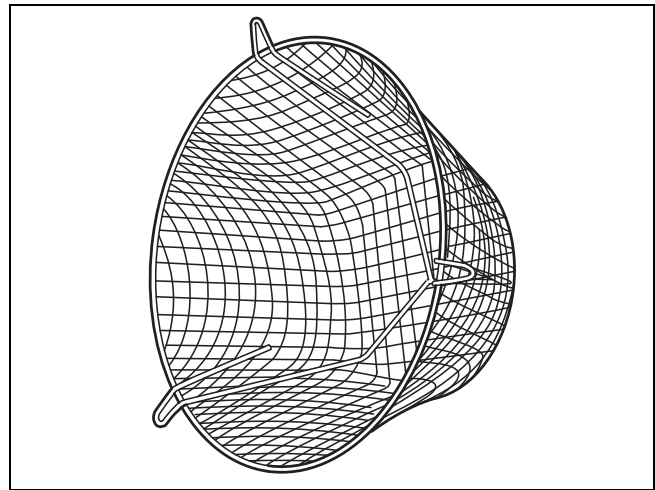

A terminal guard is required if persons could come into contact with the terminal or the terminal could be subject to damage.

If a terminal guard is required, it must be positioned to provide minimum of 50 mm clearance from any part of the terminal and be central over the terminal.

The guard should be similar to that shown in the figure.

6.5.3.3 Vertical Concentric Flue \varnothing 60/100 mm or \varnothing 80/125 mm (C33 type installation)

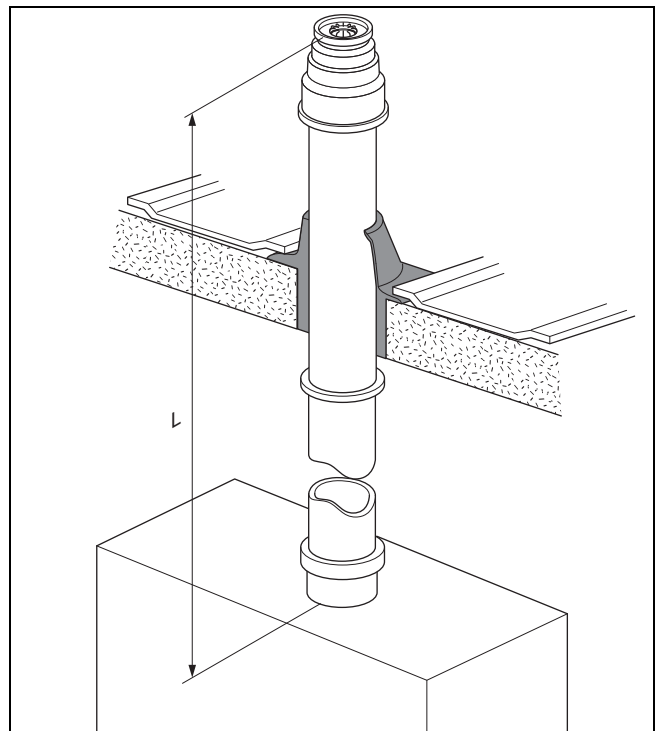

Note

If the terminal is at less than 1.80 m from the ground, you must install a terminal protection kit.

Each time an additional 90° bend is necessary (or 2 at 45°), the length (L) must be reduced (see table below).

6 Set-up

ø 60/100	24c-AS/1	28c-AS/1
Min. length (L)	0.3 m including 1 elbow	0.3 m including 1 elbow
Max. length (L)	10 m including 1 elbow	10 m including 1 elbow
Equivalence to 1 elbow 90°	1 m	1 m
Equivalence to 1 elbow 45°	0.5 m	0.5 m

ø 80/125	24c-AS/1	28c-AS/1
Min. length (L)	0.3 m including 1 elbow	0.3 m including 1 elbow
Max. length (L)	16 m including 1 elbow	20 m including 1 elbow
Equivalence to 1 elbow 90°	2.5 m	2.5 m
Equivalence to 1 elbow 45°	1 m	1 m

6.5.3.4 Multiple boiler chimney Flue ø 60/100 mm or ø 80/125 mm (C43 type installation)

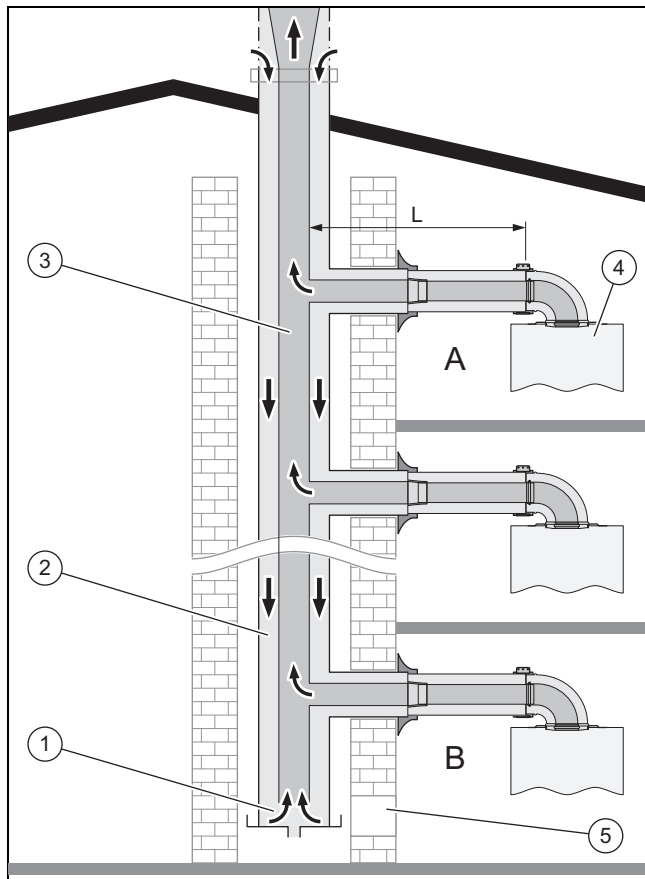

- | | | | |
|---|---------------------------|---|---------------------------|
| 1 | Pressure balancing system | 4 | Pressure balancing system |
| 2 | Air-inlet pipe | 5 | Inspection hatch |
| 3 | Collector pipe | A | Final storey |
| | | B | Ground floor |



Note

The flue connecting from the appliance to the flue system must be supplied from the manufacturer of the boiler.

C43 flue systems must not be a 'pressurised system' but act under natural draught principles.

C43 type flue systems must have their own condensate drain fitted and not allow condensate to mix into other appliances.

The flue length must be calculated and installed according to the relevant standards EN 13384-1 and 2 (C43 flue systems only) with reference to the table below and the manufacturer's instructions supplied. The appliance maximum flue length must be included when calculating the overall design of the flue system.

Each time an additional 90° bend is necessary (or 2 at 45°), the length (L) must be reduced (see table below).

ø 60/100	24c-AS/1	28c-AS/1
Min. length (L)	0.3 m	0.3 m
Max. length (L)	3 m + 3 elbow	3 m + 3 elbow
Equivalence to 1 elbow 90°	1 m	1 m
Equivalence to 1 elbow 45°	0.5 m	0.5 m

ø 80/125	24c-AS/1	28c-AS/1
Min. length (L)	0.3 m	0.3 m
Max. length (L)	3 m + 3 elbow	3 m + 3 elbow
Equivalence to 1 elbow 90°	3 m	2.5 m
Equivalence to 1 elbow 45°	1 m	1 m

6.6 Using the mounting template

- ▶ Use the mounting template to ascertain the locations at which you need to drill holes and make breakthroughs.

6.7 Wall-mounting the product

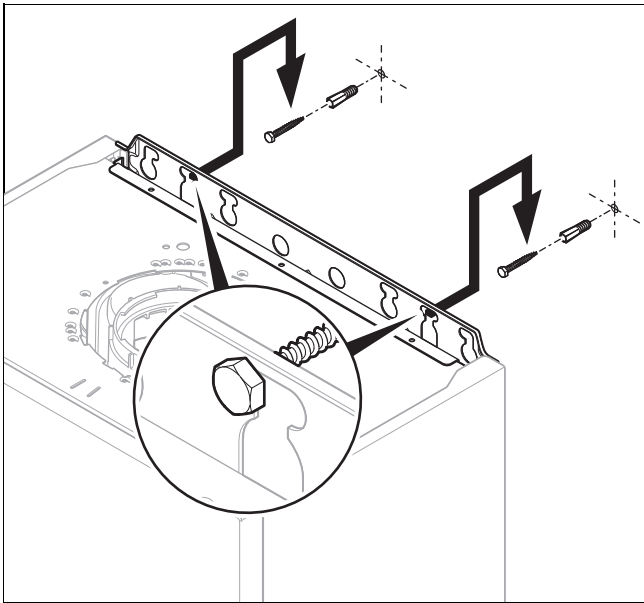

1. Check the load-bearing capacity of the wall.
2. Note the total weight of the product. (→ Page 7)
3. Only use fixing material that is permitted for the wall.
 - Screws with a minimum diameter of 6 mm
4. If required, ensure that mounting apparatus on-site has sufficient load-bearing capacity.
5. Wall-mount the product as described.

6.8 Removing/installing the front casing

6.8.1 Removing the front casing

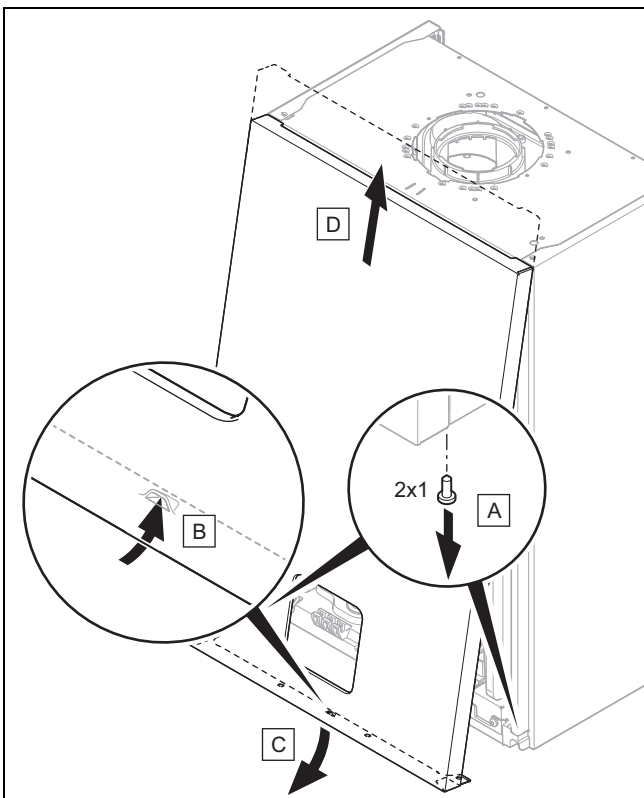

6.8.2 Installing the front casing

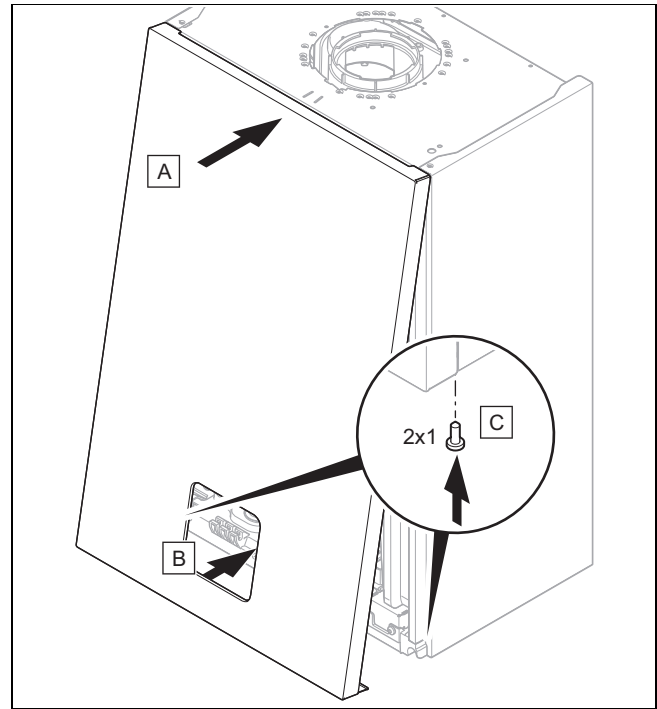

7 Installation

7 Installation



Danger!

Risk of scalding and/or risk of material damage due to incorrect installation leading to escaping water.

Mechanical stresses in connection cables can cause leaks.

- ▶ Install the connection cables voltage-free.



Caution.

Risk of material damage due to the gas leak-tightness test.

At a test pressure of >11 kPa (110 mbar), gas leak-tightness tests may cause damage to the gas valve.

- ▶ If, during gas leak-tightness tests, you also place the gas lines and the gas valve in the product under pressure, use a max. test pressure of 11 kPa (110 mbar).
- ▶ If you cannot limit the test pressure to 11 kPa (110 mbar), close any gas isolator cocks that are installed upstream from the product before you carry out the gas leak-tightness test.
- ▶ If, during gas leak-tightness tests, you have closed the gas isolator cock that is installed upstream of the product, relieve the gas line pressure before you open this gas isolator cock.



Caution.

Risk of material damage due to heat transfer during soldering.

The product's base plate is not available as a spare part. If the base plate is damaged due to excessive temperatures, the product must be viewed as a total economic write-off.

- ▶ You can solder the connectors if they have not been secured to the service valves. Once they have been secured, this is no longer possible.



Caution.

Risk of material damage caused by residues in the pipelines.

Welding remnants, sealing residues, dirt or other residues in the pipelines may damage the product.

- ▶ Flush the heating installation thoroughly before installing the product.



Warning.

Risk of adverse health effects caused by impurities in the potable water.

Sealing residues, dirt or other residues in the pipelines may adversely affect the quality of the potable water.

- ▶ Flush all of the hot and cold water pipes thoroughly before you install the product.



Caution.

Risk of material damage caused by changes to the pipes that have already been connected.

- ▶ Only bend connection pipes if they have not yet been connected to the product.

7.1 Requirements

7.1.1 Carrying out basic preparation for the installation

1. Make sure that the existing gas meter is capable of passing the rate of gas supply required.
2. Consider the maximum heat output given in DHW mode.
3. Install the connection pipes such that they are free from mechanical stress.
4. Ensure that the volumetric capacity of the integrated expansion vessel is sufficient for the system volume.
 - If the volumetric capacity of the expansion vessel is insufficient, install an additional expansion vessel as close to the product as possible
5. Insulate bare pipes exposed to environmental influences to protect them from frost using suitable insulation material.
6. Flush out the supply pipes thoroughly prior to installation.
7. Install a filling device between the cold water pipe and the heating flow.
8. Securely connect the product to the water mains. Do not use a connection hose set for this.

7.1.2 Using the correct gas type

Using the incorrect gas type may cause fault shutdowns in the product. Ignition and combustion noise may occur in the product.

- ▶ Only use the gas type listed on the data plate.

7.1.3 Information on the gas group

In the as-supplied condition, the product is preset for operation with the gas group indicated on the data plate.

7.2 Flushing the heating installation for the first time ("cold")



Note

The complete heating system must be flushed at least twice: Once with cold water and once with hot water in accordance with the following instructions.

1. Check whether all thermostatic radiator valves and both service valves on the product are open.
2. Connect a hose to the drain valve that is located at the lowest position in the heating system.
3. Open the radiator valves and the drain valves so that the water can drain quickly. Start at the next point in the installation and open the purging valves on the radiators so that the contaminated water can completely drain.
4. Close the draining cocks.
5. Refill the heating system with water.
6. Check that the expansion relief valve of the heating system is functioning correctly by turning the handle on the valve.
7. Check the pressure in the heating system and top up with water if necessary.
8. Close the filling valve and the cold water tap.

7.3 Connecting gas and water



Danger!

Risk of burns and/or risk of material damage due to incorrect installation leading to escaping gas.

Using oakum, Teflon or any other products of this sort for the gas connection thread can cause leaks.

- ▶ Only use the seal plates that are supplied with the product or those supplied by the manufacturer.

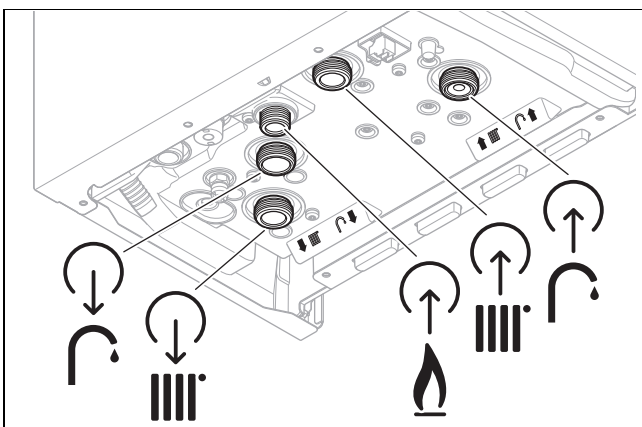

1. Install the gas pipe on the gas connection such that it is free from mechanical stress.
2. Purge the gas pipe before start-up.
3. Check the entire gas pipe properly for leak-tightness.
4. Install the water flows and returns in accordance with the relevant standards.

7.4 Connecting the condensate discharge hose



Danger!

Risk of death from escaping flue gases!

The siphon's condensate discharge hose must not be tightly connected to waste-water pipework because, otherwise, the internal condensate siphon may be drained fully and flue gas may escape.

- ▶ Have the condensate discharge hose end outside of the waste-water pipework.

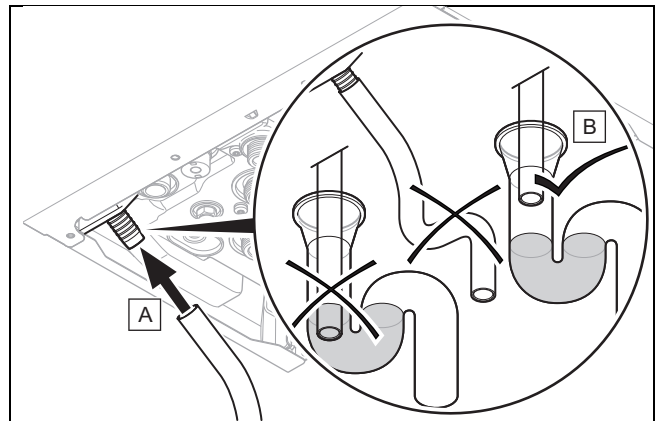

1. Follow the instructions listed here and observe the legal and local regulations on condensate discharge.
2. Use only pipes made of acid-resistant material (e.g. plastic) for the condensate discharge pipe (e.g. plastic).
3. If you cannot guarantee that the materials from which the condensate discharge pipe is made are suitable, install a system to neutralise the condensate.

7.5 Condensate discharge systems

The condensate is discharged periodically in 'slugs' by siphonic action. It is not necessary to provide extra traps in the discharge pipe as there is already a 75 mm high trap inside the boiler. Fitting an extra trap may cause the boiler siphon to work incorrectly. Refer to BS5546 or BS6798 for further advice on disposal of boiler condensate.

7.5.1 Direct Connection to internal soil and vent stack

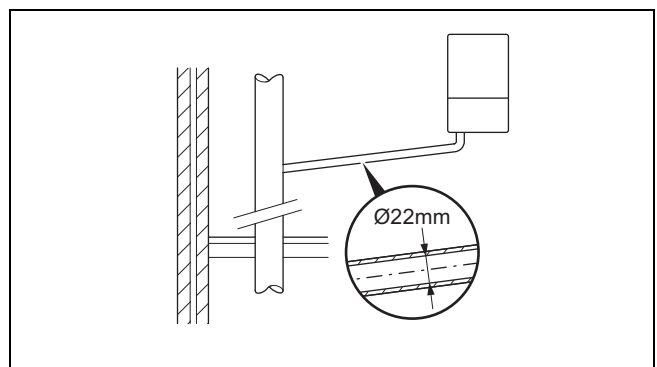

Preferred option

7 Installation

7.5.2 Direct connection to external soil and vent stack

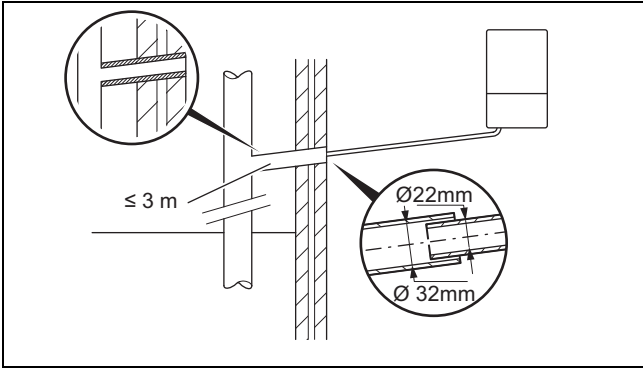

7.5.3 External termination to gully or hopper

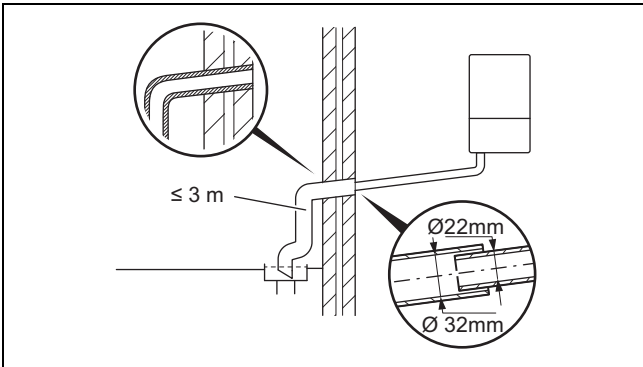

Best practice

7.5.4 Internal termination into combined sink waste

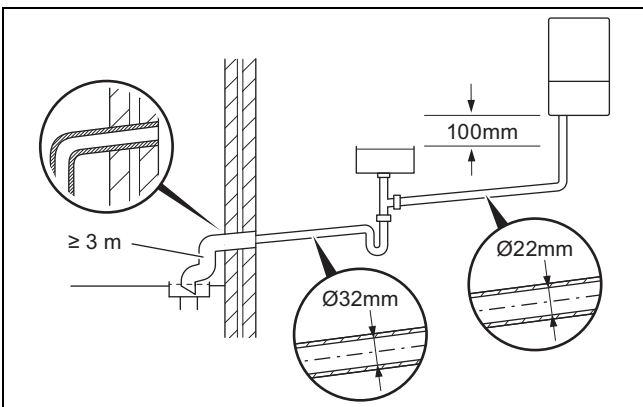

Preferred option for external termination

7.5.5 External termination into soakaway

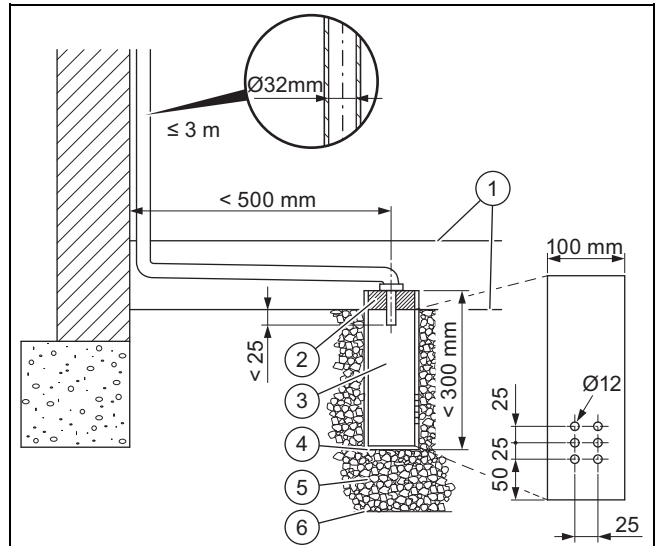

- | | | | |
|---|----------------------------------|---|------------------------------|
| 1 | Ground (either/or) | 4 | Bottom of sealed tube |
| 2 | Seal | 5 | Limestone chippings |
| 3 | Plastic tube,
100 mm diameter | 6 | Hole depth 400 mm
minimum |

Least preferred option, must not terminate in rain water drain

7.5.6 Internal termination downstream of sink waste

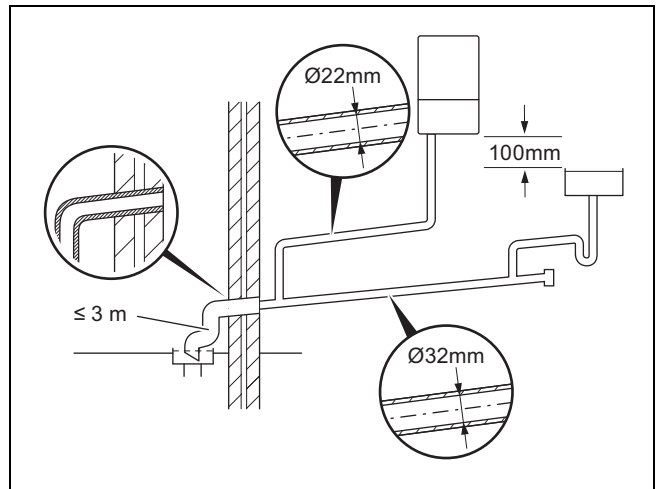

Open end of pipe direct into gully below ground level but above water level

Susceptible to siphonage, must terminate in a gully

7.5.7 External termination into rain water down pipe

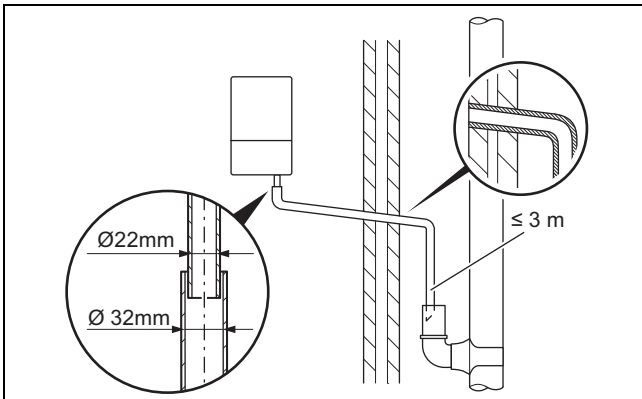

NB only combined foul/rainwater drain

7.5.8 Additional methods of introducing air breaks

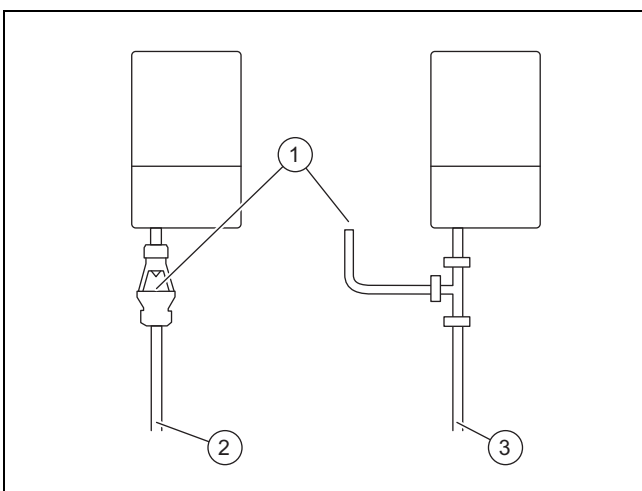

- 1 Air break
- 2 Using a tundish
- 3 Using a pipe

7.5.9 Connection of condensate pump

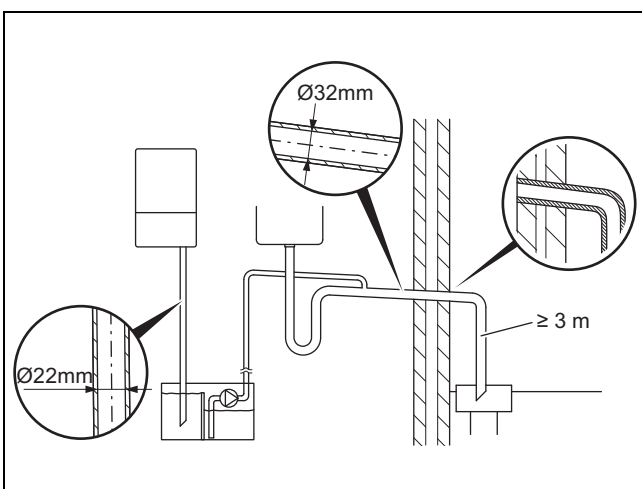

Preferred option for external connection

7.6 Connecting the drain pipework for the expansion relief valve

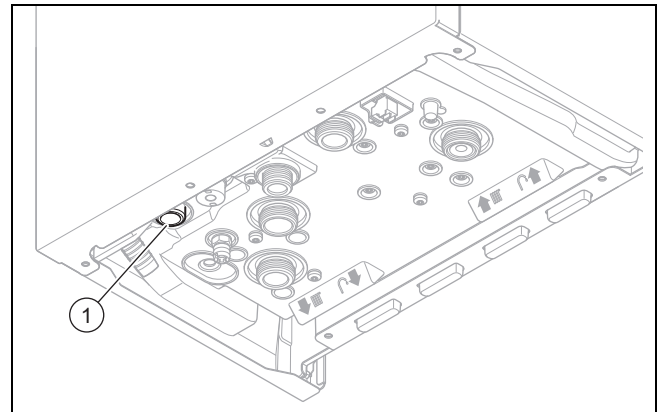

1. Ensure that the pipeline is visible.
2. Connect the expansion relief valve (1) to a suitable discharge siphon.
 - The components must be set up in such a way that you can see the water flowing out.
3. Ensure that you can view the end of the pipe and that discharged water or steam cannot cause injury to persons or damage to electronic components.

7.7 Filling the condensate siphon

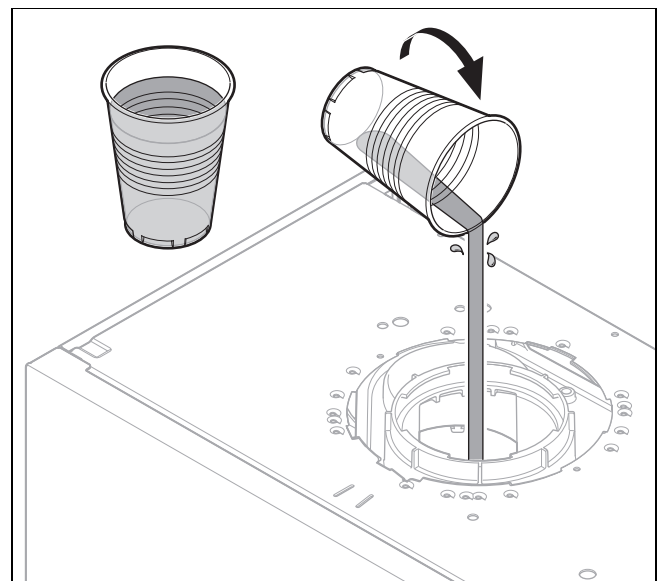

- ▶ Fill the condensate siphon with water.
 - ≈ 250 ml

7.8 Air/flue system

7.8.1 Installing and connecting the air/flue pipe

1. You can find out which air/flue pipes may be used by consulting the enclosed set-up instructions for the air/flue system.

Condition: Installation in damp rooms

- ▶ Connect the product to a room-sealed air/flue system.

7 Installation

- The combustion air must not be taken from the installation site.
- ▶ Install the air/flue pipe using the set-up instructions.

7.9 Electrical installation

Only qualified electricians may carry out the electrical installation.

The product must be earthed.



Danger!

Risk of death from electric shock!

Power supply terminals L and N remain live even if the on/off button is switched off.

- ▶ Disconnect the product from the power supply by switching off all power supplies at all poles (electrical partition with a contact gap of at least 3 mm, e.g. fuse or circuit breaker).
- ▶ Secure against being switched back on again.
- ▶ Wait for at least 3 minutes until the capacitors have discharged.
- ▶ Check that there is no voltage.

7.9.1 Opening the electronics box

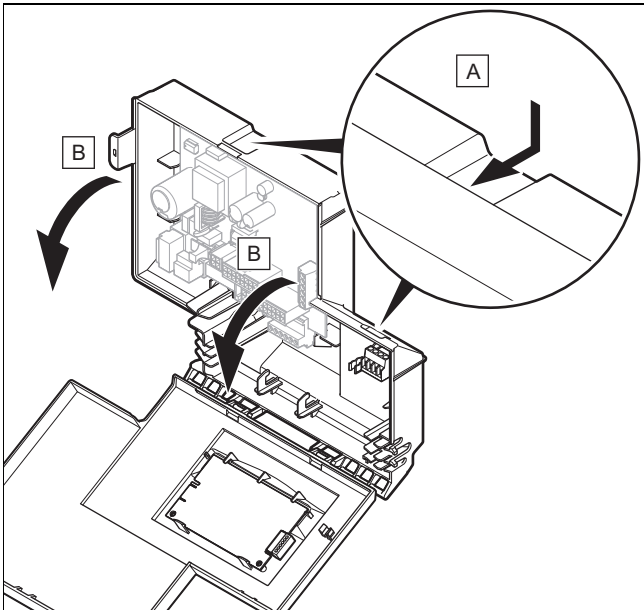

7.9.2 Cable route

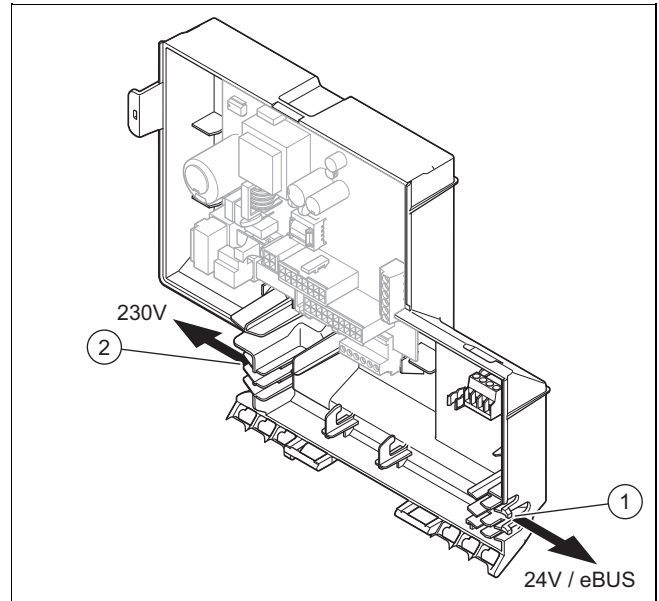

1 24-V eBUS cable route 2 230 V cable route

7.9.3 General information about connecting cables



Caution.

Risk of material damage caused by incorrect installation.

Mains voltage at incorrect terminals and plug terminals may destroy the electronics.

- ▶ Do not connect any mains voltage to the eBUS (+/-) and RT 24 V terminals.
- ▶ Only connect the connection cable to the terminals marked for the purpose.

1. Route the connection cable in the cable trunking on the underside of the product.
2. Ensure that the grommet is plugged in correctly and that the cables have been routed correctly.
3. Ensure that the grommets envelop the connection cables tightly and with no visible gaps.
4. Use the strain reliefs.
5. If required, shorten the connection cables.

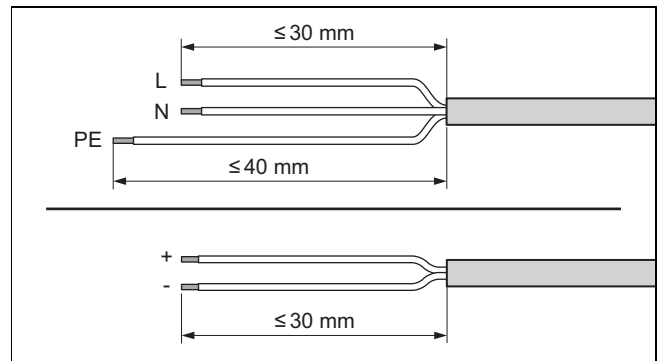

6. Strip the flexible ducts as shown in the figure. In doing so, ensure that the insulation on the individual conductors is not damaged.

7. Only strip inner conductors just enough to establish stable connections.
8. To avoid short circuits resulting from loose individual wires, fit conductor end sleeves on the stripped ends of the conductors.
9. Screw the respective plug to the connection cable.
10. Check whether all conductors are inserted mechanically securely in the plug terminals. Remedy this if necessary.
11. Plug the plug into the associated PCB slot.
Wiring diagram (→ Page 51)

7.9.4 Establishing the power supply

1. Provide one common power supply for the boiler and for the corresponding control:
 - Power supply: single-phase, 230 V, 50 Hz
 - Fuse: ≤ 3 A
2. Ensure that the mains voltage is 230 V.
3. Connect the product using a fixed connection and an electrical partition with a contact gap of at least 3 mm (e.g. fuses or power switches).
4. Make sure that access to the power supply is always available and is not covered or blocked.

7.9.5 Connecting the control



Note

When connecting to an *eBUS* room thermostat after starting up, establish the connection in order to set the heating flow and domestic hot water temperature on the product to the relevant maximum value.

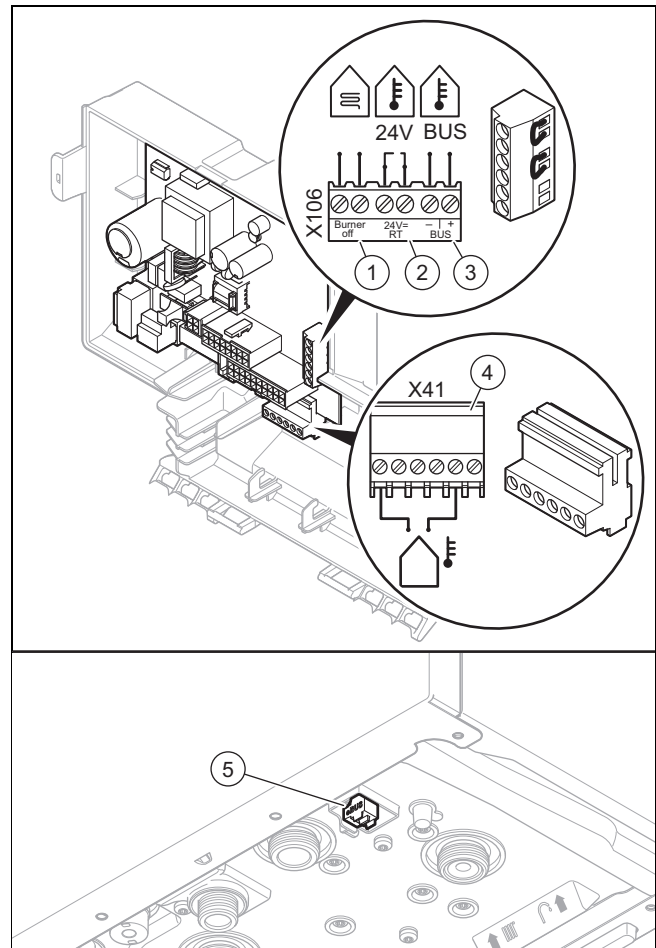

- | | | | |
|---|--|---|--|
| 1 | Limit thermostat for underfloor heating | 4 | Outdoor temperature sensor, wired |
| 2 | Control 24 V (ON/OFF) | 5 | <i>eBUS</i> control or radio receiver unit |
| 3 | <i>eBUS</i> control or radio receiver unit | | |

1. Ensure that the product is voltage-free.
2. Carry out the wiring. (→ Page 22)
3. **Alternatives 1 – Connecting the weather-compensated control or room thermostat via *eBUS*:**
 - ▶ Connect the control to the *BUS* connection (3) or (5).
 - ▶ Bridge the 24 VRT connection, if no bridge is present.
3. **Alternatives 2 – Connecting the low-voltage control (24 V):**
 - ▶ Remove the bridge and connect the control to the 24 V = RT (2) connection.
3. **Alternatives 3 – Connecting a limit thermostat for underfloor heating:**
 - ▶ Remove the bridge and connect the limit thermostat to the *Burner off* (1) connection.

7 Installation

3. Alternatives 4 – Connecting the 230 V low voltage room temperature control:

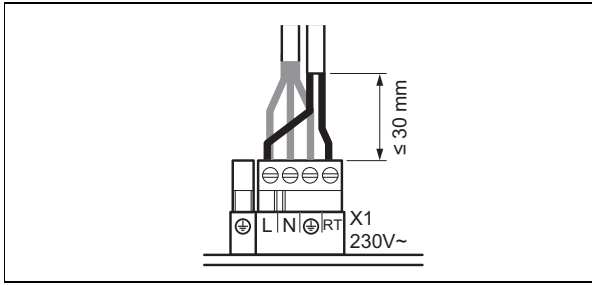

- ▶ Connect the control to the *L* main plug and to the *RT* plug.

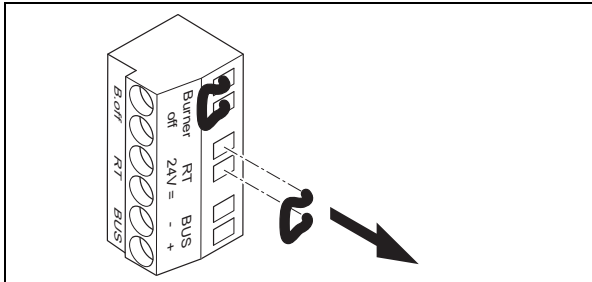





- ▶ Remove the bridge from the 24V=*RT* plug.











4. Close the electronics box.

8 Operation









8.1 Calling up the installer level

1. Press  repeatedly until the  symbol flashes.
2. Use  or  to set the competent person access code and confirm by pressing .
 - Competent person access code: 35
 - ◁ The **d.** diagnostics codes menu is displayed.





8.2 Using diagnostics codes

1. Call up the installer level. (→ Page 25)
2. Use  or  to select the diagnostics codes **d.** menu.
3. Confirm by pressing .
 - ◁ **00** is displayed.
4. Use  or  to select the diagnostics code whose value you want to change.
Diagnostics codes (→ Page 42)
5. Confirm by pressing .
6. Use  or  to select the required value for the diagnostics code.
7. Press  to confirm this setting.
8. Press  to exit the diagnostics codes.

8.3 Running check programmes

1. Call up the installer level. (→ Page 25)
2. Use  or  to select the check programmes **P.** menu.
3. Confirm by pressing .
4. Use  or  to select the required check programme.
Check programmes (→ Page 50)
5. Press  to confirm.
 - ◁ The check programme starts, is executed and stops after the intended time has elapsed.
 - ◁ The **P.** check programmes menu is shown.
6. If you want to cancel the check programme before the intended time has elapsed, press .
 - ◁ **oF** is displayed for 10 seconds.
 - ◁ The **P.** check programmes menu is shown.
7. Press  to exit the check programmes.

8.4 Calling up status codes

1. Call up the installer level. (→ Page 25)
2. Use  or  to select the status codes **S.** menu.
3. Confirm by pressing .
 - ◁ The display alternates between the current status code, the current heating flow temperature and the current water pressure.
 - **S.** → **XX** → **XX °C** → **X,X bar**
4. Press  to exit the status codes.

8.5 Exiting the installer level

- ▶ Press the  button as often as necessary in order to return to the basic display.
 - ◁ The basic display is shown.

9 Start-up

9 Start-up

During initial start-up, the operating data may initially deviate from the specified nominal data.

9.1 Carrying out the initial start-up

Initial start-up must be carried out by a customer service technician or an authorised competent person using the Benchmark Checklist. The Benchmark Checklist in the appendix (→ Page 52) of the installation instructions must be filled in and stored carefully along with the unit's documentation.

- ▶ Carry out the start-up procedure using the Benchmark Checklist in the appendix.
- ▶ Fill out and sign the Benchmark Checklist.

9.2 Checking and treating the heating water/filling and supplementary water



Caution.

Risk of material damage due to poor-quality heating water

- ▶ Ensure that the heating water is of sufficient quality.

- ▶ Before filling or topping up the installation, check the quality of the heating water.

Checking the quality of the heating water

- ▶ Remove a little water from the heating circuit.
- ▶ Check the appearance of the heating water.
- ▶ If you ascertain that it contains sedimentary materials, you must desludge the installation.
- ▶ Use a magnetic rod to check whether it contains magnetite (iron oxide).
- ▶ If you ascertain that it contains magnetite, clean the installation and apply suitable corrosion-inhibition measures, or fit a magnetic filter.
- ▶ Check the pH value of the removed water at 25 °C.
- ▶ If the value is below 8.2 or above 10.0, clean the installation and treat the heating water.
- ▶ Ensure that oxygen cannot get into the heating water.

Checking the filling and supplementary water

- ▶ Before filling the installation, measure the hardness of the filling and supplementary water.

Treating the filling and supplementary water

- ▶ Observe all applicable national regulations and technical rules when treating the filling and supplementary water.

Provided the national regulations and technical rules do not stipulate more stringent requirements, the following applies:

You must treat the heating water in the following cases

- If the entire filling and supplementary water quantity during the operating life of the system exceeds three times the nominal volume of the heating installation, or
- If the guideline values listed in the following table are not met, or
- If the pH value of the heating water is less than 8.2 or more than 10.0.

Total heating output	Water hardness at specific system volume ¹⁾					
	≤ 20 l/kW		> 20 l/kW ≤ 50 l/kW		> 50 l/kW	
kW	ppm CaCO ₃	mol/m ³	ppm CaCO ₃	mol/m ³	ppm CaCO ₃	mol/m ³
< 50	< 300	< 3	200	2	2	0.02
> 50 to ≤ 200	200	2	150	1.5	2	0.02
> 200 to ≤ 600	150	1.5	2	0.02	2	0.02
> 600	2	0.02	2	0.02	2	0.02

1) Nominal capacity in litres/heating output; in the case of multi-boiler systems, the smallest single heating output is to be used.



Caution.

Risk of material damage if the heating water is treated with unsuitable additives.

Unsuitable additives may cause changes in the components, noises in heating mode and possibly subsequent damage.

- ▶ Do not use any unsuitable antifreeze and corrosion inhibitors, biocides or sealants.

No incompatibility with our products has been detected to date with proper use of the following additives.

- ▶ When using additives, follow the manufacturer's instructions without exception.

We accept no liability for the compatibility of any additive or its effectiveness in the rest of the heating system.

Additives for cleaning measures (subsequent flushing required)

- Adey MC3+
- Adey MC5
- Fernox F3
- Sentinel X 300
- Sentinel X 400

Additives intended to remain permanently in the installation

- Adey MC1+
- Fernox F1
- Fernox F2
- Sentinel X 100
- Sentinel X 200

Additives for frost protection intended to remain permanently in the installation

- Adey MC ZERO
- Fernox Antifreeze Alpha 11
- Sentinel X 500

- ▶ If you have used the above-mentioned additives, inform the end user about the measures that are required.
- ▶ Inform the end user about the measures required for frost protection.

9.3 Filling the heating installation



Note

After each start-up, the product works at reduced output when starting in order to facilitate the heat transfer effect. This does not apply for check programmes and does not result in any loss of comfort for the end user. Status code **S.58** corresponds to this phase. The display shows a temperature of approx. 50 °C in this phase.

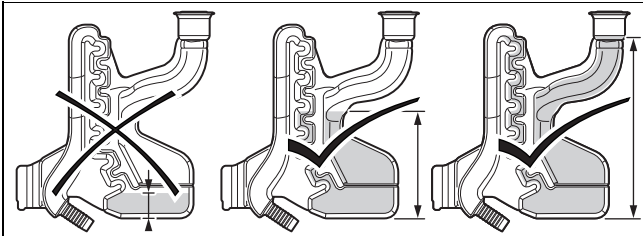

1. Ensure that the condensate siphon has been filled correctly.
2. Before filling the heating installation, ensure that it has been flushed out sufficiently.
3. Connect the filling/draining cock in the heating installation to a heating water supply in accordance with the relevant standards.
4. Open all of the thermostatic radiator valves and, if required, the service valves.
5. Open the heating water supply and the filling tap so that the heating water flows into the heating installation.
 - ◁ The heating circuit is automatically purged via the hose that is connected to the pump.

Starting up the product

6. Press the on/off button .
 - ◁ The display shows the basic display.
7. Start check programme **P.08**. (→ Page 25)
Check programmes (→ Page 50)
 - ◁ The product's heating circuit is automatically purged via the hose that is connected to the pump.
8. Purge the highest radiator until water flows out of the purging valve without bubbles.
9. Purge all other radiators until the entire heating installation has been completely filled with heating water.
10. Close all purging valves.
11. Fill with heating water until the required filling pressure is reached.
 - 0.10 to 0.14 MPa (1.00 to 1.40 bar)
 - ▽ If the heating installation extends over several storeys, higher filling pressures may be required to avoid air entering the heating installation.
12. Close the filling tap and the heating water supply.
13. Check all of the connections and the entire circuit for leaks.

9.4 Purging the heating installation

1. Start the check programme **P.00**. (→ Page 25)
Check programmes (→ Page 50)
 - ◁ **on** is shown in the display.
2. Make sure that the filling pressure of the heating installation does not fall below the minimum filling pressure.
 - ≥ 0.05 MPa (≥ 0.50 bar)
3. Check whether the filling pressure of the heating installation is at least 0.02 MPa (0.2 bar) above the diaphragm expansion vessel's counter-pressure ($P_{\text{system}} \geq P_{\text{diaphragm expansion vessel}} + 0.02$ MPa (0.2 bar)).

Result:
Filling pressure of the heating installation is too low

 - ▶ Refill the heating installation.
4. If there is still too much air in the heating installation at the end of the check programme **P.00**, restart the check programme.

9.5 Filling and purging the domestic hot water system

1. Open the cold-water isolation valve on the product.
2. To fill the domestic hot water circuit, open all of the domestic hot water tap fittings until water escapes.

9.6 Check and gas setting

9.6.1 Checking the factory-set gas setting

- ▶ Check the information about the gas type indicated on the data plate and compare this with the gas type available at the installation site.

Result 1:

The product design is not compatible with the local gas group.

- ▶ Do not start up the product.
- ▶ Contact customer service.

Result 2:

The product design is compatible with the local gas group.

- ▶ Check the gas connection pressure/gas flow pressure. (→ Page 28)
- ▶ Check the CO₂ content. (→ Page 29)

9.6.2 Checking the air/flue pipe/flue gas recirculation

1. Check the flue gas installation is intact in accordance with the latest gas safe technical bulletin and information supplied in the installation instructions.
2. For extended flue gas installations check for flue gas recirculation using the air analysis point.
3. Use a flue gas analyser.
4. If you discover unusual levels of CO or CO₂ in the supply air, search for the leak in the flue system or for signs of flue gas recirculation.
5. Eliminate the damage properly.
6. Check again whether the supply air contains any unusual levels of CO or CO₂.
7. If you cannot eliminate the damage, do not start up the product.

9 Start-up

9.6.3 Checking the gas flow rate

The boiler is fitted with a multifunctional automatic gas valve which ensures that the precise air/gas ratio is provided under all operating conditions. The gas flow rate has been set during production and does not require adjustment. With the front casing fitted check the gas flow rate of the boiler as follows:

- ▶ Start up the product with the check programme **P.01**.
- ▶ In addition, ensure that maximum heat can be dissipated into the heating system by turning up the room thermostat.
- ▶ Wait at least 5 minutes until the boiler has reached its operating temperature.
- ▶ Ensure that all other gas appliances in the property are turned off.
- ▶ Measure the gas flow rate at the gas meter.
- ▶ Compare the measured values with the corresponding values in the table.

Validity: MicraCom 24c-AS/1 (H-GB)

Qnw from the data plate	H gas in m ³ /h			P gas in m ³ /h		
	Nom.	+5%	-10%	Nom.	+5%	-10%
6.2	0.65	0.68	0.59	–	–	–
8.4	–	–	–	0.34	0.36	0.31
18.8	1.98	2.08	1.78	0.77	0.81	0.69
24	2.53	2.66	2.28	0.98	1.03	0.88

Validity: MicraCom 28c-AS/1 (H-GB)

Qnw from the data plate	H gas in m ³ /h			P gas in m ³ /h		
	Nom.	+5%	-10%	Nom.	+5%	-10%
7.2	0.76	0.80	0.68	0.29	0.30	0.26
24.5	2.58	2.71	2.32	1.00	1.05	0.90
28	2.95	3.10	2.66	1.15	1.21	1.04

Condition: Gas flow rate not in the permissible range

- ▶ Check all of the piping and ensure that the gas flow rates are correct.
- ▶ Only put the product into operation once the gas flow rates have been corrected.

Condition: Gas flow rate in the permissible range

- ▶ End check programme **P.01**.
- ▶ Allow the boiler to cool down by allowing pump overrun to operate for a minimum of two minutes.
- ▶ Record the boiler maximum gas flow rate onto the Benchmark gas boiler commissioning checklist.

9.6.4 Checking the gas connection pressure/gas flow pressure

1. Temporarily decommission the product. (→ Page 41)
2. Hinge the electronics box downwards.

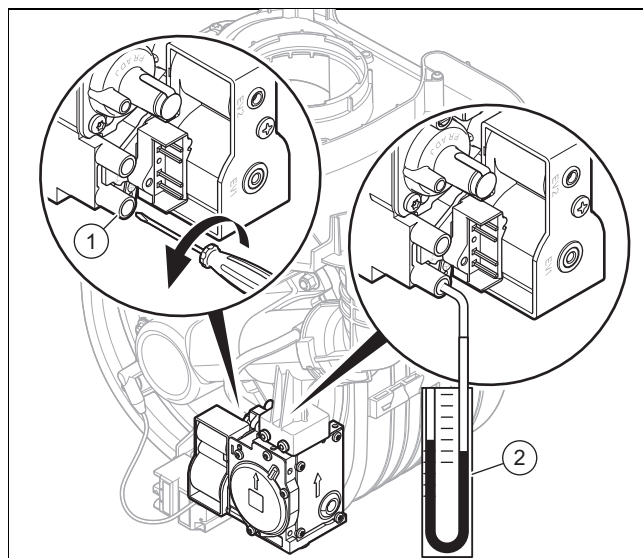

3. Turn the screw on the gas pressure measuring point (1) anti-clockwise.
 - Anti-clockwise (⊖): Two rotations
4. Connect a manometer (2) to the test nipple (1).
 - Working materials: U tube manometer
 - Working materials: Digital pressure gauge
5. Hinge the electronics box upwards.
6. Open the gas stopcock.
7. Start up the product with check programme **P.01** (in doing so, set the output to the maximum). (→ Page 25)
8. Measure the gas connection pressure/gas flow pressure against the atmospheric pressure.

Permissible connection pressure

Natural gas	H	1.7 to 2.5 kPa (17.0 to 25.0 mbar)
Liquefied petroleum gas	P	2.5 to 4.5 kPa (25.0 to 45.0 mbar)



Note

The connection pressure is measured at the gas valve assembly, meaning that the permissible minimum value may be 0.1 kPa (1 mbar) lower than the minimum value specified in the table.

Result 1:

Gas connection pressure/gas flow pressure in the permissible range

- ▶ Temporarily decommission the product. (→ Page 41)
- ▶ Hinge the electronics box downwards.
- ▶ Remove the manometer.
- ▶ Tighten the screw on the test nipple.
- ▶ Open the gas stopcock.
- ▶ Check the test nipple for gas tightness.
- ▶ Hinge the electronics box upwards.
- ▶ Install the front casing. (→ Page 17)
- ▶ Start up the product.

Result 2:

Gas connection pressure/gas flow pressure not in the permissible range



Caution.
Risk of material damage and operating faults caused by incorrect gas connection pressure/gas flow pressure.

If the gas connection pressure/gas flow pressure lies outside the permissible range, this can cause operating faults in and damage to the product.

- ▶ Do not make any adjustments to the product.
- ▶ Do not start up the product.

- ▶ If you are unable to eliminate the fault, contact the gas supply company.
- ▶ Close the gas stopcock.

9.6.5 Checking the CO₂ content

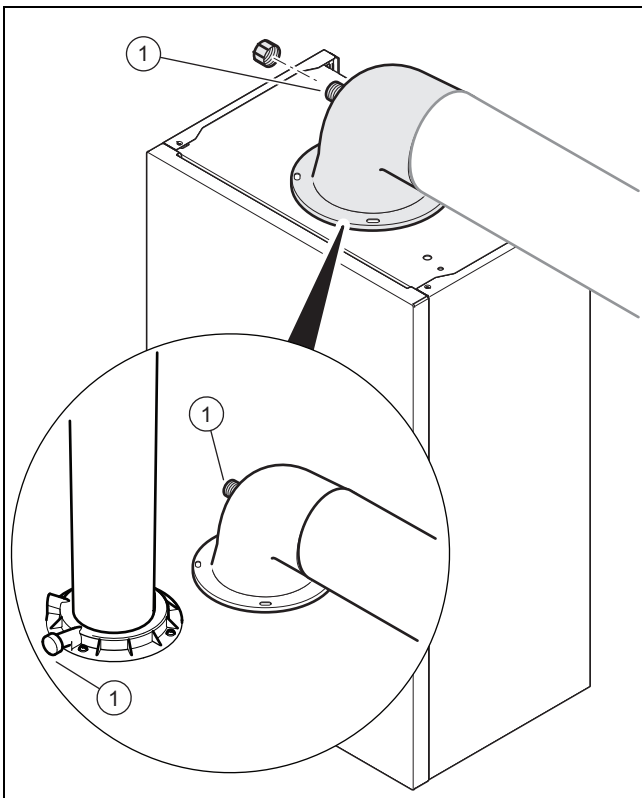

1. Open the test opening at the flue gas analysis point (1).
2. Position the sensor for the CO₂ analyser in the centre of the flue pipe.
3. Start up the product with check programme **P.01**. (→ Page 25)
4. Wait at least five minutes until the product reaches its operating temperature.
5. Measure the CO₂ content at the flue gas analysis point and log the measured value.

Checking the CO₂ content

Fitted front casing	Natural gas	H	9.2 ±1 %
	Liquefied petroleum gas	P	10.6 ±0.5 %

Result 1:

If the value is outside of the permitted range:

- ▶ Measure the CO₂ content at the flue gas analysis point again and log the measured value.
- ▶ If the value is still outside of the permissible range, do not start up the product and, instead, report this to customer service.

Result 2:

If the value is inside the permitted range:

- ▶ Continue with the process of starting up the product.
6. Remove the sensor for the CO₂ analyser and close the test opening at the flue gas analysis point.

9.6.6 Performing a gas conversion

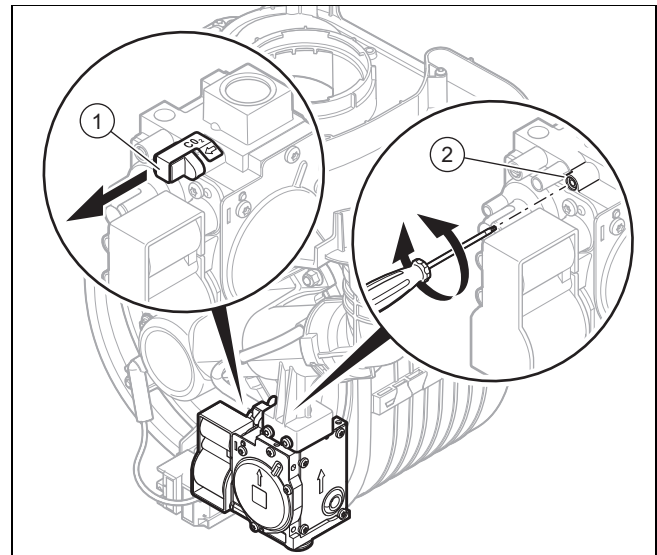

1. Press the on/off button (⏻) in order to switch off the product.
 ◀ The display shows **oF** and then goes out.
2. Disconnect the product from the power grid.
3. Remove the plug (1).
4. To convert the gas type, turn the screw (2) by the specified number of rotations clockwise (↻) or anti-clockwise (↺).

Setting the gas valve assembly

H → P	Clockwise rotation	Three revolutions
P → H	Anti-clockwise rotation	Three revolutions

5. Check the CO₂ content and adjust this. (→ Page 33)
6. Set diagnostics code **d.85** in order to adjust the product's minimum output. (→ Page 25)

Setting diagnostics code D.85

	H → P	P → H
24c-AS/1	9 kW	6 kW
28c-AS/1	8 kW	7 kW

10 Adapting the unit to the installation

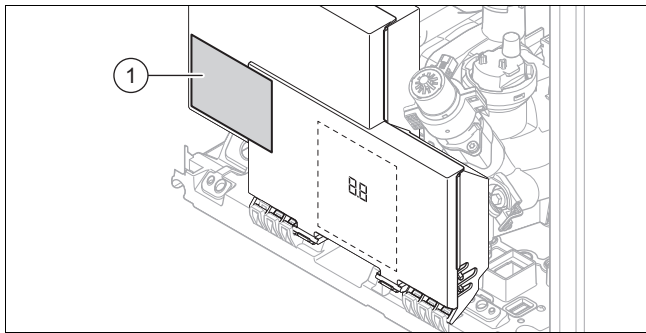

7. Mark the gas type that is used on the gas conversion sticker.
8. Stick the gas conversion sticker (1) to the electronics box.

9.7 Checking the heating mode

1. Make sure that there is a heat requirement.
2. Activate the display of the status codes. (→ Page 25)
 - ◁ If the product is working correctly, the display shows **S.04**.
 - ▽ If the filling function for the condensate siphon has been activated, **S.58** is displayed as a priority.

9.8 Checking the domestic hot water generation

1. Open a hot water tap completely.
2. Activate the display of the status codes. (→ Page 25)
 - ◁ If the product is working correctly, the display shows **S.14**.

9.9 Checking leak-tightness

- ▶ Check the gas pipe, the heating circuit and the hot water circuit for leak-tightness.
- ▶ Check that the air/flue pipe has been installed correctly.

Condition: Room-sealed operation

- ▶ Check whether the vacuum chamber has been closed tightly.

9.10 Thoroughly flushing the heating installation ("hot")

1. Operate the appliance until the boiler and the heating system are up to temperature.
2. Check the heating system for leaks.
3. Connect a hose to the drain valve located at the lowest position of the heating system.
4. Shut off the boiler, open the drain valve and all purge valves on the radiators and allow the water to flow out of the heating system and the boiler quickly and fully.
5. Close the drain valve.
6. Fill the heating system again with water as described in "Filling and purging the heating installation" (→ Page 27).
7. Re-fill the system until the system design pressure of 0,1 MPa (1,0 bar) is attained.



Note

The actual reading on the digital pressure gauge should ideally be 0,05 MPa (0,5 bar) plus an additional pressure corresponding to the highest point of the system above the base of the boiler – 10 m head equals an additional 1 bar reading on the pressure gauge. The minimum pressure should not be less than 0,1 MPa (1 bar) in any installation. If the system is to be treated with an inhibitor it should be applied at this stage in accordance with the manufacturer's instructions.

See the section on checking and preparing the heating water. (→ Page 26)

8. Install the front casing. (→ Page 17)

10 Adapting the unit to the installation

10.1 Adapting the heating settings

10.1.1 Burner anti-cycling time

To prevent frequent switching on and off of the burner and thus prevent energy losses, an electronic restart lockout is activated for a specific period each time the burner is switched off. The burner anti-cycling time is only active for the heating mode. Switching on domestic hot water mode during the burner anti-cycling time has no effect.

You can use diagnostics code **d.02** to set the maximum burner anti-cycling time (factory setting: 20 min.).

T _{Flow} (target) °C	Set maximum burner anti-cycling time min						
	1	5	10	15	20	25	30
30	2.0	4.0	8.5	12.5	16.5	20.5	25.0
35	2.0	4.0	7.5	11.0	15.0	18.5	22.0
40	2.0	3.5	6.5	10.0	13.0	16.5	19.5
45	2.0	3.0	6.0	8.5	11.5	14.0	17.0
50	2.0	3.0	5.0	7.5	9.5	12.0	14.0
55	2.0	2.5	4.5	6.0	8.0	10.0	11.5
60	2.0	2.0	3.5	5.0	6.0	7.5	9.0
65	2.0	1.5	2.5	3.5	4.5	5.5	6.5
70	2.0	1.5	2.0	2.5	2.5	3.0	3.5
75	2.0	1.0	1.0	1.0	1.0	1.0	1.0

T _{Flow} (target) °C	Set maximum burner anti-cycling time min					
	35	40	45	50	55	60
30	29.0	33.0	37.0	41.0	45.0	49.5
35	25.5	29.5	33.0	36.5	40.5	44.0
40	22.5	26.0	29.0	32.0	35.5	38.5
45	19.5	22.5	25.0	27.5	30.5	33.0
50	16.5	18.5	21.0	23.5	25.5	28.0
55	13.5	15.0	17.0	19.0	20.5	22.5
60	10.5	11.5	13.0	14.5	15.5	17.0
65	7.0	8.0	9.0	10.0	11.0	11.5
70	4.0	4.5	5.0	5.5	6.0	6.5

T _{Flow} (target) °C	Set maximum burner anti-cycling time min					
	35	40	45	50	55	60
75	1.0	1.0	1.0	1.0	1.0	1.0

10.1.2 Setting the pump output

10.1.2.1 Pump mode setting

The product is equipped with a stage-controlled high-efficiency pump. In the automatic operating mode (d.14 = 0), the pump stage is regulated in such a way that a constantly available pressure is guaranteed.

If required, you can manually set the pump mode to five fixed, selectable stages based on the maximum possible output. This switches the speed regulation off.

- To convert the pump output, change d.14 to the desired value.
Diagnostics codes (→ Page 42)

10.1.2.2 Pump diagram - pressure loss graph

Validity: MicraCom 24c-AS/1 (H-GB)

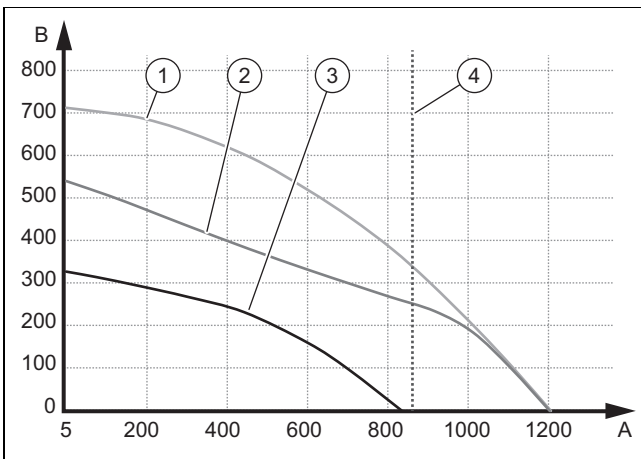

- | | | | |
|---|---|---|--|
| 1 | Max. pump speed, bypass valve closed | 3 | Min. pump speed, bypass valve opened by 3/4 rotation |
| 2 | Max. pump speed, bypass valve opened by 3/4 rotation (factory setting for the bypass valve) | 4 | Q _{max} (ΔT = 20 °C) |
| | | A | Installation volume flow in l/h |
| | | B | Remaining pump head in hPa (mbar) |

Validity: MicraCom 28c-AS/1 (H-GB)

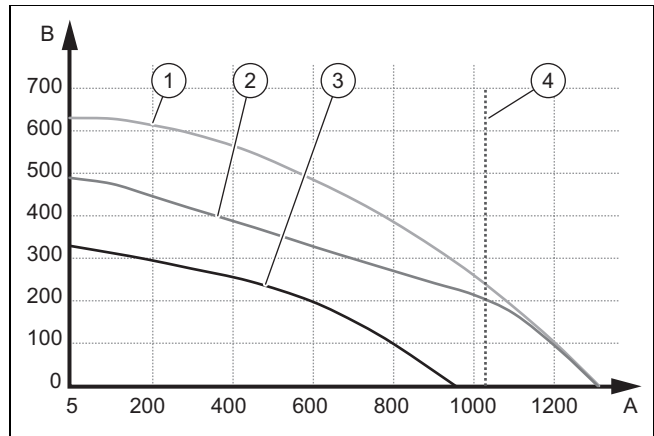

- | | | | |
|---|---|---|--|
| 1 | Max. pump speed, bypass valve closed | 3 | Min. pump speed, bypass valve opened by 3/4 rotation |
| 2 | Max. pump speed, bypass valve opened by 3/4 rotation (factory setting for the bypass valve) | 4 | Q _{max} (ΔT = 20 °C) |
| | | A | Installation volume flow in l/h |
| | | B | Remaining pump head in hPa (mbar) |

10.1.3 Setting the bypass valve

1. Remove the front casing. (→ Page 17)
2. Hinge the electronics box downwards.

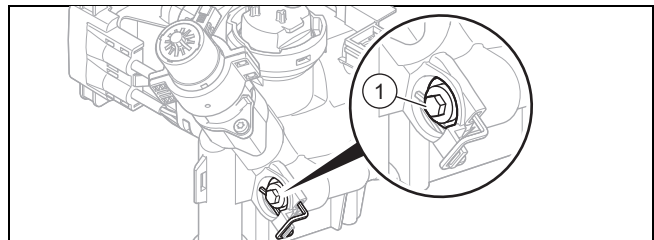

3. Regulate the pressure using the adjusting screw (1).

Position of the adjusting screw	Pressure	Notes/application
Right-hand stop (turned all the way down)	0.035 MPa (0.350 bar)	If the radiators do not heat up sufficiently at the factory setting. In this case, you must set the pump to the maximum speed.
3/4 revolution anti-clockwise	0.025 MPa (0.250 bar)	Factory setting
Three further anti-clockwise rotations starting from the mid-position	0.017 MPa (0.170 bar)	If noises occur at radiators or radiator valves.

4. Hinge the electronics box upwards.
5. Install the front casing. (→ Page 17)

11 Handing over to the end user

10.1.4 Setting the heating and domestic hot water temperature

Condition: If installing a control is not intended

- ▶ Set the desired heating flow and domestic hot water temperature on the product (→ Operating instructions for the product).

Condition: If installing a control is intended

- ▶ Set the heating flow and domestic hot water temperature on the product to the relevant maximum value (→ Operating instructions for the product).
- ▶ Connect the control to the product. (→ Page 23)
- ▶ Set the desired heating flow and domestic hot water temperature on the control (→ Operating instructions for the control).

10.1.5 Domestic hot water

10.1.5.1 Descaling the water

Scale deposition increases as the water temperature increases.

- ▶ Descale the water as required.

11 Handing over to the end user

- ▶ At the time of commissioning complete all relevant sections of the Benchmark commissioning checklist, located at the rear of this document.
- ▶ For IE: Complete a “Declaration of Conformity” to indicate compliance to I.S. 813. An example of this is given in the current edition of I.S. 813.
- ▶ When you have finished the installation, affix the enclosed sticker (which requests that the user reads the instructions) to the front of the product in the end user's language.
- ▶ Draw attention, to the current issue of the Gas Safety (Installation and Use) Regulations, Section 35, which imposes a duty of care on all persons who let out any property containing a gas appliance in the UK.
- ▶ Explain to the end user how the safety devices work and where they are located.
- ▶ Inform the end user how to handle the product.
- ▶ In particular, draw attention to the safety warnings that the end user must follow.
- ▶ Inform the end user that they must have the product maintained in accordance with the specified intervals.
- ▶ Pass all of the instructions and documentation for the product to the end user for safe-keeping.
- ▶ Inform the end user about measures taken to ensure the supply of combustion air and flue gas guiding, and instruct the operator that he must not make any changes.
- ▶ Inform the end user that they must not store or use explosive or highly flammable substances (such as petrol, paper or paint) in the installation room of the product.
- ▶ Complete and sign off the Benchmark commissioning checklist.
- ▶ Complete and sign off the guarantee documentation.

12 Inspection and maintenance

- ▶ Adhere to the minimum inspection and maintenance intervals.
- ▶ Carry out maintenance work on the product at an earlier point if the results of the inspection that was carried out during previous maintenance make this necessary.

12.1 Complete Service Interval Record section

- ▶ After servicing, complete the relevant Service Interval Record section of the Benchmark Checklist located on the inside back pages of this document.

12.2 Checking and setting the CO₂ content



Note

Only a qualified competent person is authorised to implement the CO₂ setting on the gas valve assembly.

Each destroyed tamper-proof seal must be replaced with a new tamper-proof seal. The CO₂ adjusting screw must be sealed.

Never modify the factory setting of the gas pressure regulator of the gas valve assembly.

1. Check the CO₂ content. (→ Page 29)
 - ▽ If the value is not correct, set the CO₂ content.

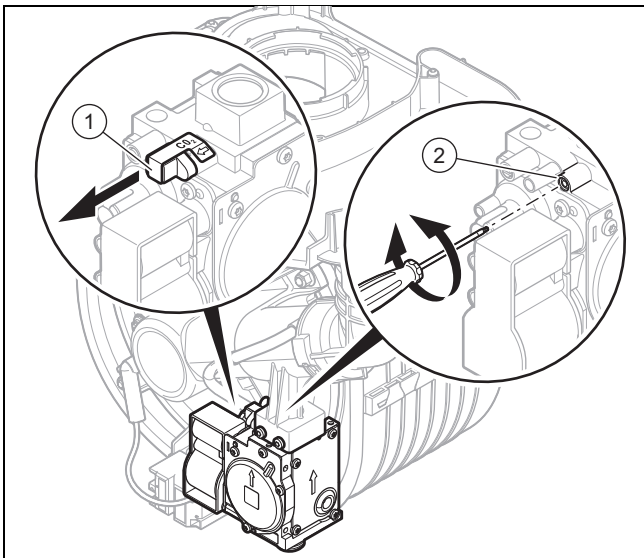

2. Remove the sticker.
3. Remove the covering cap (1).
4. Turn the screw (2) to set the CO₂ content (value with front casing removed).
 - ◁ To increase the CO₂ content: Turn anti-clockwise
 - ◁ To decrease the CO₂ content: Turn clockwise



Note

For natural gas only: Only perform the adjustment in small increments of a 1/8 turn and wait approx. one minute after each adjustment until the value stabilises.

For liquefied petroleum gas only: Only perform the adjustment in extremely small increments (approx. 1/16 turn), and wait approx. one minute after each adjustment until the value stabilises.

5. Compare the measured value with the corresponding value in the table.

Setting the CO ₂ content	Removed front casing	Fitted front casing
	Natural gas H	Natural gas H
CO ₂ at full load	9.0 ±0.3 vol. %	9.2 ±0.3 vol. %
Set for Wobbe index W ₀	14.09 kW·h/m ³	14.09 kW·h/m ³
O ₂ at full load	4.9 ±0.5 vol. %	4.5 ±0.5 vol. %
CO at full load	≤ 250 ppm	≤ 250 ppm
CO/CO ₂	≤ 0.0027	≤ 0.0027

Setting the CO ₂ content	Removed front casing	Fitted front casing
	Liquefied petroleum gas P	Liquefied petroleum gas P
CO ₂ at full load	10.4 ±0.3 vol. %	10.6 ±0.3 vol. %
Set for Wobbe index W ₀	21.34 kW·h/m ³	21.34 kW·h/m ³
O ₂ at full load	5.4 ±0.4 vol. %	5.1 ±0.4 vol. %
CO at full load	≤ 250 ppm	≤ 250 ppm
CO/CO ₂	≤ 0.0024	≤ 0.0024

- ▽ If the setting is not in the specified adjustment range, do not start up the product.

- ▶ Contact customer service.
6. Check whether the air-quality requirements with regard to carbon monoxide are fulfilled.
 7. Refit the covering cap (1).
 8. Install the front casing.

12 Inspection and maintenance

12.3 Moving the expansion vessel to the maintenance position on the combustion block

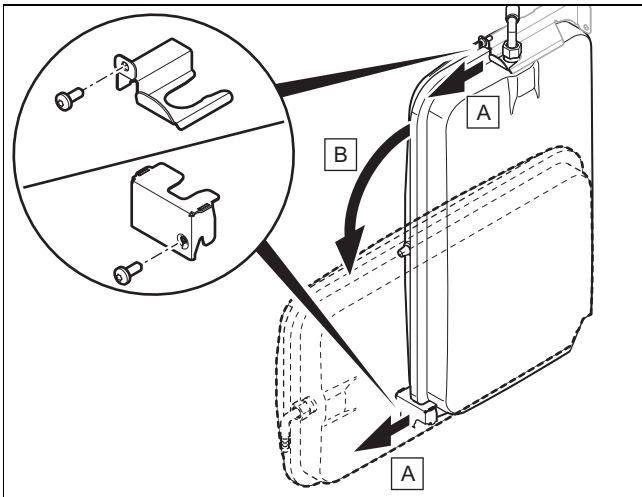

- ▶ Depending on the components on which you want to work, move the expansion vessel to the maintenance position.

12.4 Moving the expansion vessel to the maintenance position on the hydraulic block

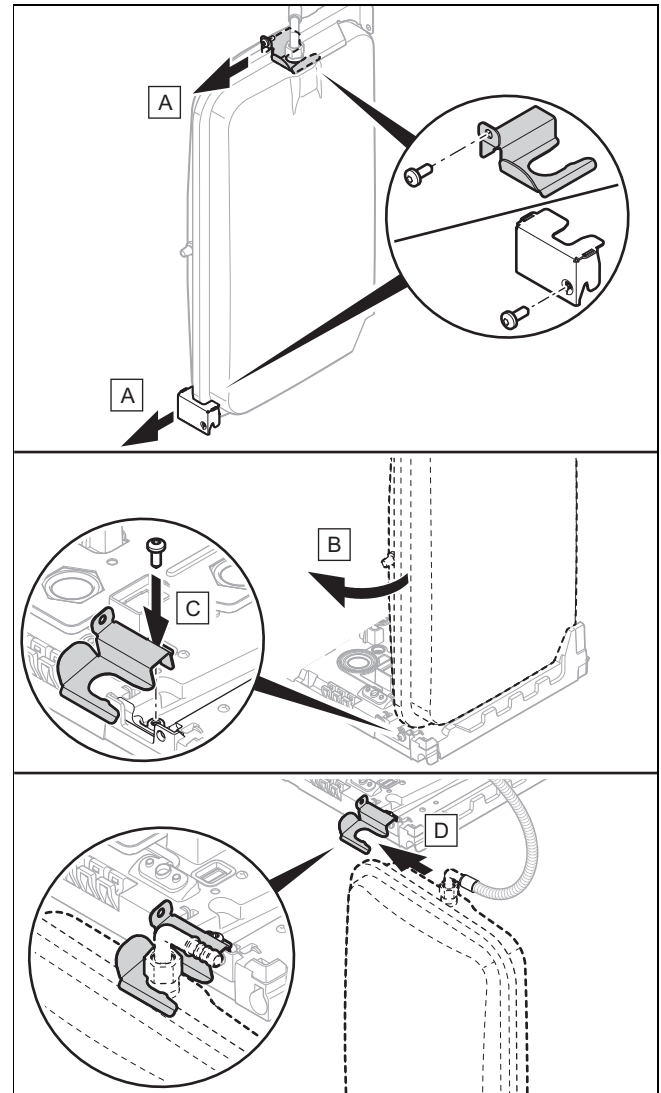

- ▶ Depending on the components on which you want to work, move the expansion vessel to the maintenance position.

12.5 Cleaning/checking the components

Carry out the preparatory work before cleaning/checking any of the components.

- ▶ Prepare the cleaning and inspection work. (→ Page 34)

Carry out the work required to finish the task after cleaning/checking any of the components.

- ▶ Complete the cleaning and inspection work. (→ Page 38)

12.5.1 Preparing the cleaning and inspection work

1. Drain the product when you are carrying out work on hydraulic components. (→ Page 39)
2. Temporarily decommission the product. (→ Page 41)
 - Take all necessary precautions to ensure that it cannot be switched back on again.
3. Disconnect the product from the mains power.
4. Close the service valves of the product.
5. Remove the front casing. (→ Page 17)
6. Hinge the electronics box downwards.

7. Protect the electrical components (e.g. the electronics box) from spraying water.
8. Use only new seals.

12.5.2 Removing the compact thermal module



Danger!

Risk of death and risk of material damage caused by hot flue gas.

The seal, insulating mat and self-locking nuts on the burner flange must not be damaged. Otherwise, hot flue gases may escape and cause personal injury and material damage.

- ▶ Replace the seal each time you open the burner flange.
- ▶ Replace the self-locking nuts on the burner flange each time you open the burner flange.
- ▶ If the insulating mat on the burner flange or on the back panel of the heat exchanger shows signs of damage, replace the insulating mat.



Note

The compact thermal module consists of four main components:

- Gas valve assembly,
- Venturi and restrictor for the reference pressure pipe,
- Burner flange,
- Premix burner.

1. Never remove the venturi from the burner flange.

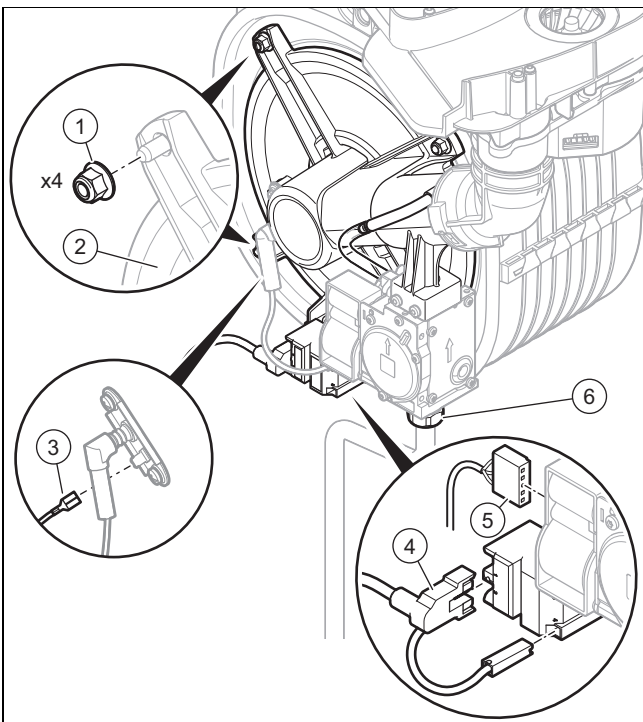

2. Remove the plug (5) from the gas valve assembly.

3. Remove the plug (4) from the ignition device.
4. Remove the earth cable (3) from the ignition electrode.
5. Unscrew the union nut (6) from the gas valve assembly.
6. Undo the four nuts (1) on the burner flange (2).

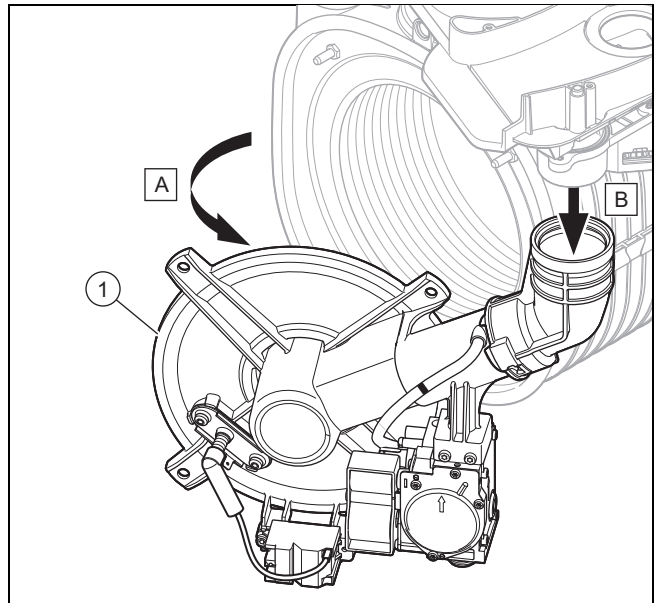

7. Remove the entire compact thermal module (1) from the heat exchanger.
8. Check the burner and burner insulating mat for damage. (→ Page 36)
9. Check the heat exchanger for damage.

Result:

Heat exchanger damaged

- ▶ Replace the heat exchanger (→ "Heat exchanger" spare parts instructions).

10. Check the heat exchanger for dirt.

Result:

Heat exchanger dirty

- ▶ Clean the heat exchanger. (→ Page 36)

11. Check the insulating mat on the heat exchanger for damage.

Result:

Insulating mat damaged

- ▶ Replace the insulating mat (→ Spare parts instructions for the heat exchanger insulating mat).

12 Inspection and maintenance

12.5.3 Cleaning the heat exchanger

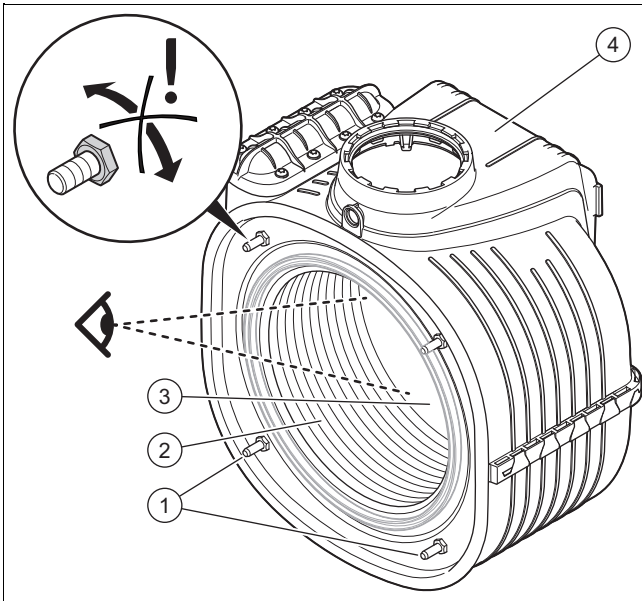

1. Clean the heating coil (2) on the heat exchanger (4) using water or, if required, vinegar (to a maximum of 5% acid).
 - Cleaning agent reaction time: 20 min
2. Use a plastic brush or sufficiently strong jet of water to remove the loosened dirt (for example, by using a spray bottle with ascending pipe). In doing so, ensure that no spraying water reaches the other components. Do not point the jet of water directly at the insulating mat (3) on the rear of the heat exchanger.
 - ◁ The water flows out of the heat exchanger through the condensate siphon.
3. Check the insulating mat (3) on the burner flange for damage.

Result:

Insulating mat damaged

- Replace the insulating mat (→ Spare parts instructions for the heat exchanger insulating mat).

12.5.4 Checking the burner and burner insulating mat for damage

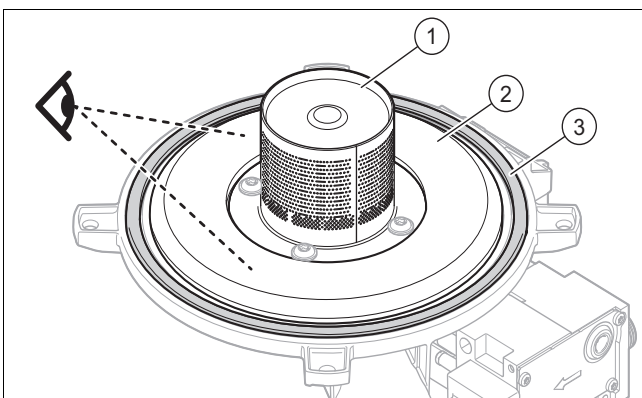

1. Check the surface of the burner (1) for damage.

Result:
Burner damaged

 - Replace the burner.
2. Fit a new burner flange seal (3).

3. Check the insulating mat (2) on the burner flange for damage.

Result:

Insulating mat damaged

- Replace the insulating mat (→ Spare parts instructions for the burner flange insulating mat).

12.5.5 Installing the compact thermal module

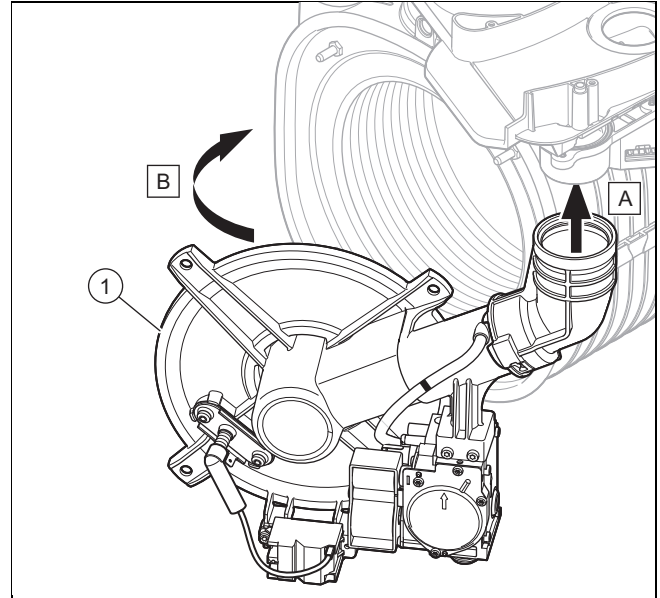

1. Connect the air intake pipe to the intake stub.
2. Connect the compact thermal module (1) to the heat exchanger.

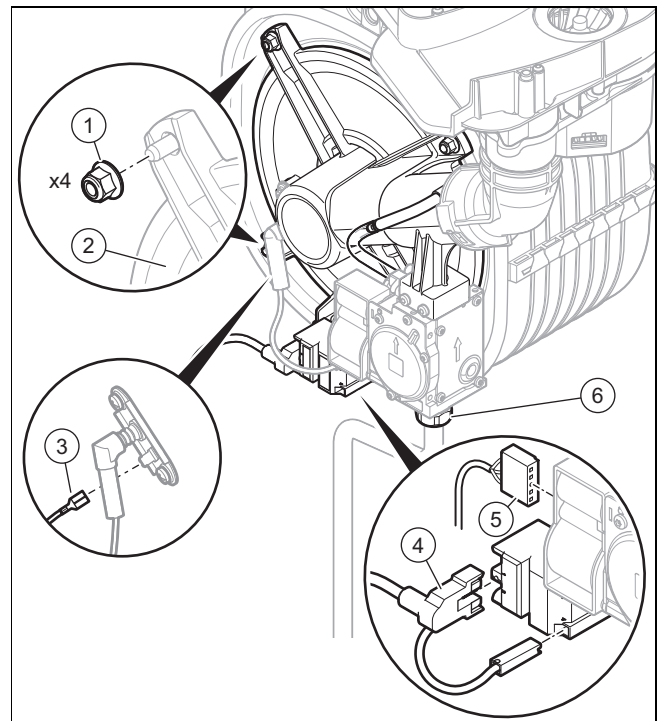

3. Tighten the four nuts (1) in a cross-wise pattern until the burner flange fits closely and uniformly onto the mating surfaces.

- Tightening torque: 6 Nm, if a torque spanner is available

4. Reconnect the earth cable (3) to the ignition electrode.
5. Reconnect the plug (5) to the gas valve assembly.
6. Reconnect the plug (4) to the ignition device.
7. Screw the union nut (6) back onto the gas valve assembly with a new seal.
8. Connect the gas pipe using a new seal.
9. Open the gas stopcock.
10. Check the product for tightness. (→ Page 30)
11. Check the gas connection pressure/gas flow pressure. (→ Page 28)

12.5.6 Checking the ignition electrode

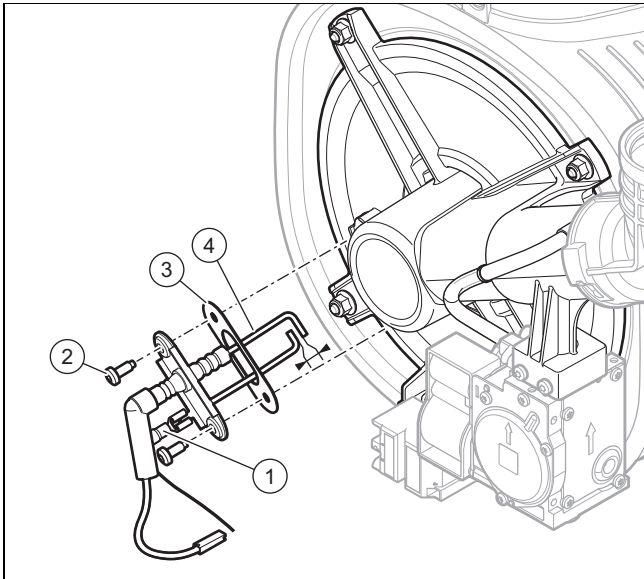

1. Remove the earth cable (1).
2. Remove the fixing screws (2).
3. Carefully remove the electrode (4) from the combustion chamber.
4. Ensure that the electrode ends are undamaged.
5. Clean and check the gap between the electrodes.
 - Clearance for the ignition electrodes: 4.5 ± 0.5 mm
6. Replace the seal (3).
7. Install the electrode. To do this, proceed in reverse order.

12.5.7 Checking and cleaning the restrictor for the reference pressure pipe

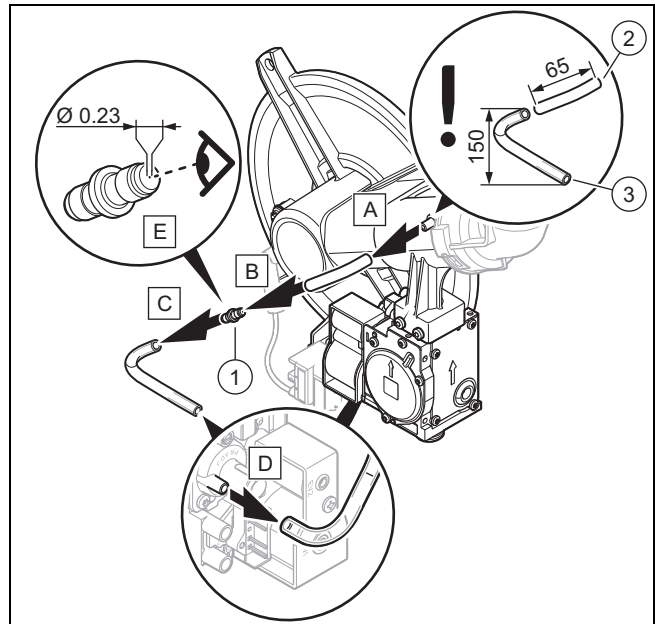

1. Remove the restrictor for the reference pressure pipe (1), as shown in the figure → (A) to (D).
2. Ensure that the hole for the restrictor for the reference pressure pipe (1) is not blocked (E).

Result:

Hole for the restrictor for the reference pressure pipe is blocked

- Clean the hole by blowing it out using compressed air.

3. Ensure that the reference pressure pipes (2) and (3) are not blocked.

Result:

Reference pressure pipes blocked

- Clean the reference pressure pipes by blowing them out using compressed air.

4. Install the unit in reverse order and, in doing so, ensure that you do not mix up the reference pressure pipes.
 - Observe the illustrated instructions.

12.5.8 Checking the pre-charge pressure of the expansion vessel

1. Drain the product. (→ Page 39)

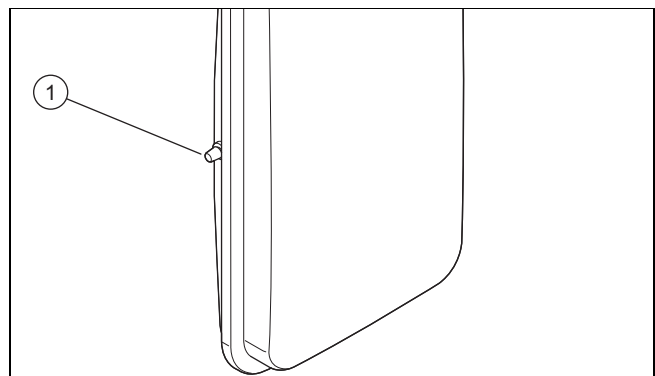

2. Check the pre-charge pressure of the expansion vessel at the expansion vessel valve (1).
 - Working materials: U tube manometer

12 Inspection and maintenance

- Working materials: Digital pressure gauge

Result 1:

≥ 0.075 MPa (≥ 0.750 bar)

The pre-charge pressure is in the permissible range.

Result 2:

< 0.075 MPa (< 0.750 bar)

- ▶ Fill the expansion vessel in accordance with the static height of the heating installation; ideally with nitrogen, otherwise with air. Ensure that the drain valve is open when topping up.

3. If water escapes from the valve of the expansion vessel, replace the expansion vessel.
4. Fill the heating installation. (→ Page 27)
5. Purge the heating installation. (→ Page 27)

12.5.9 Cleaning the heating filter

1. Drain the product on the heating side.
2. Hinge the electronics box forwards.

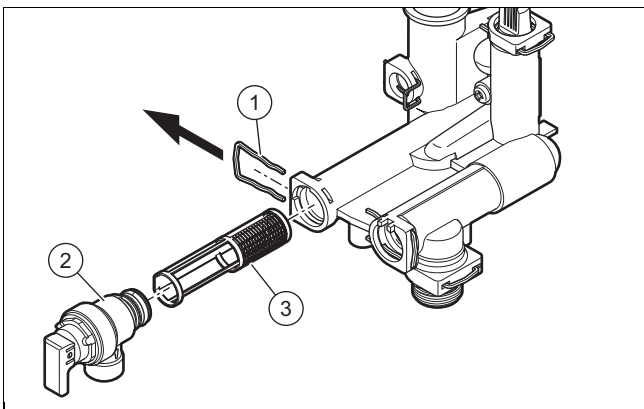

3. Remove the clamp (1).
4. Remove the expansion relief valve (2).
5. Remove the heating filter (3) from its bracket.
6. Rinse the heating filter under running water, against the direction of flow.
7. If the strainer is damaged or it can no longer be cleaned sufficiently, you must replace the strainer.
8. Use only new seals.
9. Reinsert the heating filter, the expansion relief valve and the clips.

12.5.10 Cleaning the condensate siphon

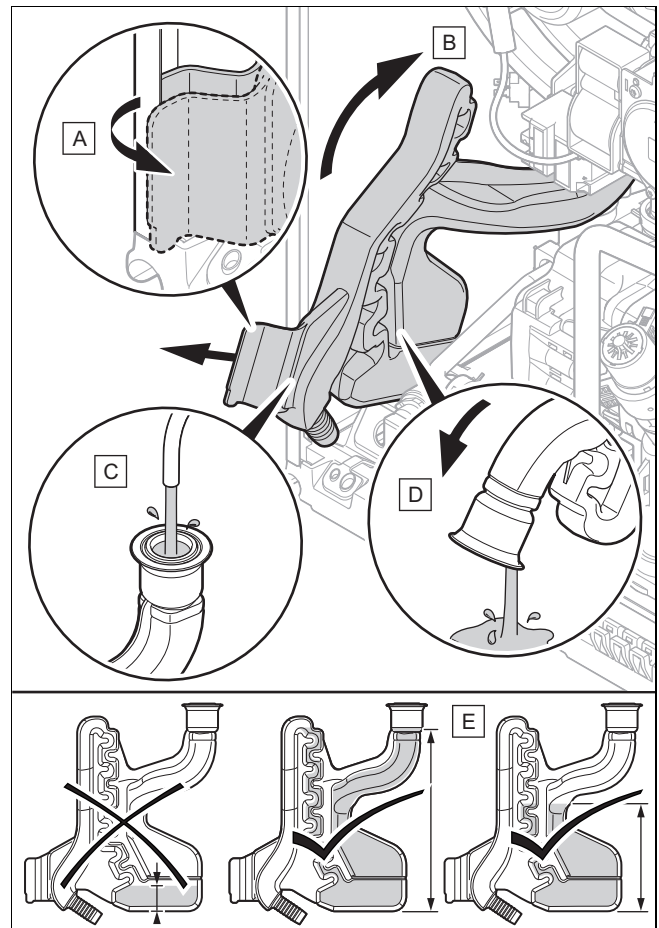

1. Disconnect the condensate discharge hose from the lower section of the siphon.
2. Clean the condensate siphon as shown in the figure → (A) to (D).
3. Check whether the seal is still present on the heating heat exchanger.
 - ▽ If the seal is no longer present or is damaged, replace it.
4. Fill the condensate siphon (E).
5. Reattach the condensate siphon.
6. Connect the condensate discharge hose.

12.5.11 Completing cleaning and inspection work

1. Hinge the electronics box upwards.
2. Install the front casing. (→ Page 17)
3. Establish the power supply if this has not yet been done.
4. Open all service valves and the gas stopcock if this has not yet been done.
5. Switch the product back on if this has not yet been done. (→ Page 27)
6. Check the product for tightness. (→ Page 30)

12.6 Draining the product

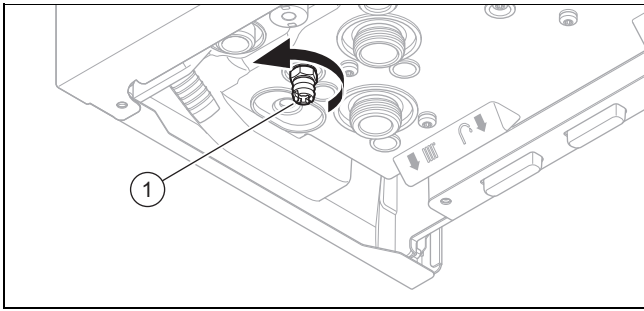

1. Close the service valves of the product.
2. Remove the front casing. (→ Page 17)
3. **Alternatives 1:**
 - ▶ Place a container under the drain cock (1).
3. **Alternatives 2:**
 - ▶ Connect the drain cock (1) to the sewage system.
4. Unscrew the automatic air vent cap from the internal pump.
5. Start up the product.
6. Open the drain cock (1).
7. Start check programme **P.08**. (→ Page 25)
 - ◁ The product (heating circuit) is drained.
8. Close the drain cock as soon as the product has drained.
9. Turn the cap on the automatic air vent to close it.
10. Install the front casing. (→ Page 17)
11. Temporarily decommission the product. (→ Page 41)

12.7 Completing inspection and maintenance work

- ▶ Check the gas connection pressure/gas flow pressure. (→ Page 28)
- ▶ Check the CO₂ content. (→ Page 29)
- ▶ Check the product for tightness. (→ Page 30)
- ▶ Log the inspection/maintenance work.
- ▶ Fill out the relevant Service Record section in the Benchmark Checklist located at the rear of this document.

13 Troubleshooting

13.1 Querying the fault memory

1. Call up the installer level. (→ Page 25)
2. Use (+) to select the fault memory **F**. menu.
3. Confirm by pressing (✓).
4. Use (-) or (+) to scroll through the last 10 faults in the cylinder.
 - ◁ Number **01** in the sequence corresponds to the fault that occurred last.
 - ◁ The sequence position and fault number are displayed alternately.
5. Press (←) to exit the fault memory.
6. Exit the installer level. (→ Page 25)

13.2 Eliminating faults

Active faults appear in the display's basic display.

- ▶ Call up the fault memory to find out which faults occurred most recently on the product. (→ Page 39)
- ▶ Use the table in the appendix to eliminate the faults. Fault codes (→ Page 46)
- ▶ Press and hold the (⏻) button for longer than three seconds to reset the product (maximum five times).
 - ◁ **rE** is shown in the display.
 - ▽ **rE** flashes rapidly after five reset attempts.
 - ▶ Press (✓) to stop the flashing and to restart the product.
- ▶ If you are unable to eliminate the fault and the fault recurs despite several reset attempts, contact Customer Service.

13.3 Resetting parameters to factory settings

1. Note down the installation-specific settings and the set values for **d.50** and **d.51**. (→ Page 25)
2. Set diagnostics code **d.96** to **1**. (→ Page 25)
 - ◁ Parameters are restored to the factory settings.
3. Check the installation-specific settings and the set values for **d.50** and **d.51**, and adjust these, if required.
4. Exit the installer level. (→ Page 25)

13.4 Replacing defective components

Carry out the preparatory work before replacing any of the components.

- ▶ Prepare the repair work. (→ Page 39)

Carry out the completion work after replacing any of the components.

- ▶ Complete the repair work. (→ Page 40)

13.4.1 Procuring spare parts

The original components of the product were also certified by the manufacturer as part of the declaration of conformity. If you use other, non-certified or unauthorised parts during maintenance or repair work, this may void the conformity of the product and it will therefore no longer comply with the applicable standards.

We strongly recommend that you use original spare parts from the manufacturer as this guarantees fault-free and safe operation of the product. To receive information about the available original spare parts, contact the contact address provided on the back page of these instructions.

- ▶ If you require spare parts for maintenance or repair work, use only the spare parts that are permitted for the product.

13.4.2 Preparing the repair work

1. Drain the product when you are carrying out work on hydraulic components. (→ Page 39)
2. Temporarily decommission the product. (→ Page 41)

13 Troubleshooting

- Take all necessary precautions to ensure that it cannot be switched back on again.
- 3. Disconnect the product from the mains power.
- 4. Close the service valves of the product.
- 5. Remove the front casing. (→ Page 17)
- 6. Hinge the electronics box downwards.
- 7. Protect the electrical components (e.g. the electronics box) from spraying water.
- 8. Use only new seals.

13.4.3 Replacing the gas valve assembly



Note

Each destroyed tamper-proof seal must be replaced with a new tamper-proof seal.

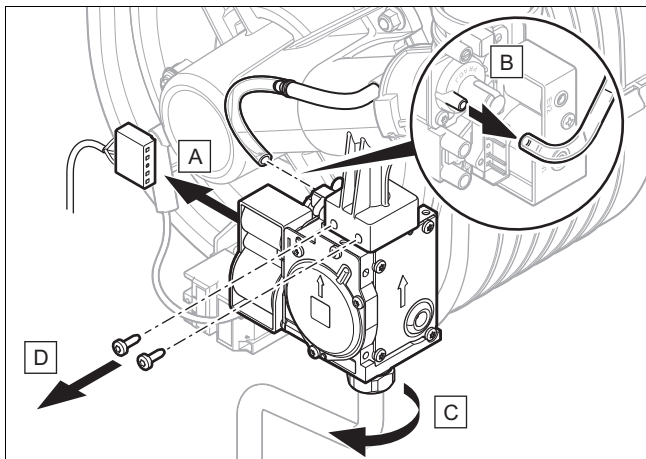

1. Remove the gas valve assembly as shown in the figure.
2. Install the new gas valve assembly in reverse order.
3. Attach the two screws to the gas valve assembly.
 - Tightening torque: 2 Nm, if a torque spanner is available
4. When restarting the product, carry out a leak-tightness test, check the CO₂ content and, if required, adjust this.

13.4.4 Replacing the fan

1. Move the expansion vessel to the maintenance position on the combustion block. (→ Page 34)
2. Remove the compact thermal module. (→ Page 35)

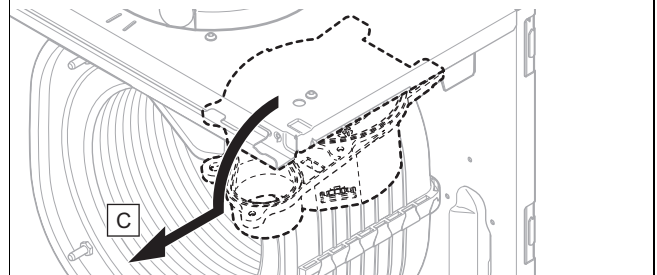
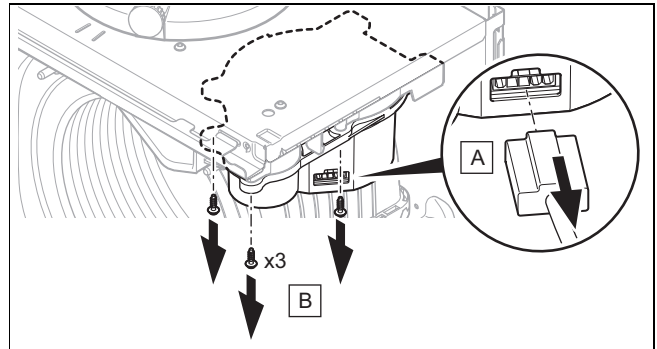

3. Remove the fan as shown in the figure.
4. Reinstall the new fan in the reverse order.
5. Install the compact thermal module. (→ Page 36)
6. Reinstall the expansion vessel.
7. When restarting the product, check the CO₂ content and, if required, adjust this.

13.4.5 Replacing the pump head

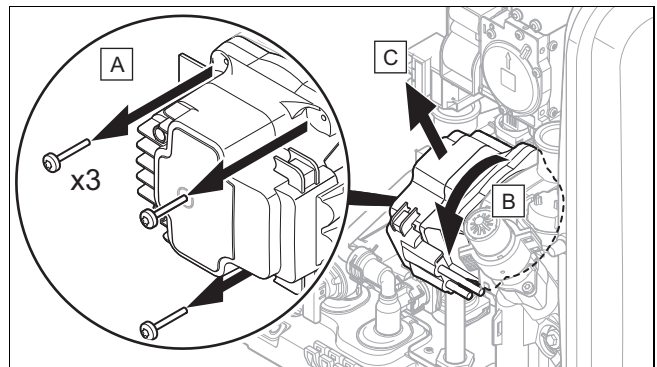

1. Remove the pump head as shown in the figure.
2. Install the new pump head in reverse order.

13.4.6 Completing repair work

1. Hinge the electronics box upwards.
2. Install the front casing. (→ Page 17)
3. Establish the power supply if this has not yet been done.
4. Open all service valves and the gas stopcock if this has not yet been done.
5. Switch the product back on if this has not yet been done. (→ Page 27)
6. Check the product for tightness. (→ Page 30)

14 Decommissioning

14.1 Temporary decommissioning

1. Press the on/off button .
◁ The display shows **oF** and then goes out.
2. Close the gas stopcock.
3. Disconnect the product from the mains power.

14.2 Permanently decommissioning

1. Drain the product. (→ Page 39)
2. Press the on/off button .
◁ The display shows **oF** and then goes out.
3. Disconnect the product from the mains power.
4. Close the gas stopcock.
5. Close the stopcock on the cold water connection.

15 Recycling and disposal

Disposing of the packaging

- ▶ Dispose of the packaging correctly.
- ▶ Observe all relevant regulations.
- ▶ For detailed information refer to www.vaillant.co.uk.

Appendix

A Inspection and maintenance work

The table below lists the manufacturer requirements with respect to minimum inspection and maintenance intervals. If national regulations and directives require shorter inspection and maintenance intervals, you should observe these instead of the intervals listed. Each time inspection and maintenance work is carried out, carry out the required preparatory and completion work.

#	Maintenance work	Interval	
1	Record all of the analysis results in the Benchmark Checklist in these instructions	Annually	
2	Check the tightness of the air/flue pipe, make sure that it is not damaged and has been attached correctly, and check that it has been set up correctly	Annually	
3	Removing dirt from the product and the vacuum chamber	Annually	
4	Visually checking the condition of the heat cell, checking for corrosion, rust or damage	Annually	
5	Checking the gas connection pressure at maximum heat input	Annually	
6	Checking the CO ₂ content	Annually	29
7	Recording the CO ₂ content (the air ratio)	Annually	
8	Check that the connections/electrical plug connections have been connected correctly/function correctly (product must be voltage-free)	Annually	
9	Check that the gas stopcock and service valves function correctly	Annually	
10	Cleaning the condensate siphon	Annually	38
11	Cleaning the heating filter	Annually	38
12	Checking the pre-charge pressure of the expansion vessel	at regular intervals	37
13	Removing the compact thermal module	at regular intervals	35
14	Cleaning the heat exchanger	at regular intervals	36
15	Checking the burner and burner insulating mat for damage	at regular intervals	36
16	Checking the insulating mats in the combustion area and replacing damaged insulating mats	at regular intervals	
17	Installing the compact thermal module	at regular intervals	36
18	Checking the ignition electrode	at regular intervals	37
19	Checking the filling pressure of the heating installation	Annually	
20	Run a function test for the product/heating installation and the domestic hot water generation. If required, carry out purging.	Annually	
21	Completing inspection and maintenance work	Annually	39

B Diagnostics codes



Note

Since the code table is used for various products, some codes may not be visible for the product in question.

Code	Parameter	Values		Unit	Increment, select, explanation	Factory setting
		Min.	Max.			
d.00	Maximum heat output is fixed or adjusts automatically	–	–	kW	The maximum heat output varies depending on the product. → Section "Technical data" Au = Automatic: Product automatically adjusts the maximum output to the current system demand	Au = Automatic
d.01	Pump overrun time in heating mode	1	60	min	Increment = 1	5
d.02	Maximum burner anti-cycling time in heating mode	2	60	min	Increment = 1	20
d.05	Determined target heating flow temperature	Current value		°C	–	–

Code	Parameter	Values		Unit	Increment, select, explanation	Factory setting
		Min.	Max.			
d.06	Target domestic hot water temperature	Current value		°C	–	–
d.08	Status of the 230 V room thermostat	Current value		–	OF = Open (0 V, no heating mode) on = Closed (230 V, heating mode)	–
d.09	Target heating flow temperature that is set on the eBUS room thermostat	Current value		°C	–	–
d.10	Status of the internal pump in the heating circuit	Current value		–	OF = Pump off on = Pump on	–
d.11	Status of the heating circuit's shunt pump	Current value		–	Applies to: Installed heating circuit shunt pump (optional) OF = Pump off on = Pump on	–
d.13	Status of the domestic hot water circuit's circulation pump	Current value		–	Applies to: Installed domestic hot water circuit circulation pump (optional) OF = Pump off on = Pump on	–
d.14	Operating mode of the modulating pump	0	5	–	0 = Speed-regulated (automatic pump operation in levels 1 to 5) 1 = PWM = 55 % 2 = PWM = 65 % 3 = PWM = 75 % 4 = PWM = 85 % 5 = PWM = 95 % 1; 2; 3; 4; 5 = Fixed rotational speeds → Section "Setting the pump output"	0
d.15	Pump speed	Current value		%	Hi = 100%	–
d.16	Status of the 24 V room thermostat (ON/OFF)	Current value		–	OF = Heating off on = Heating on or eBUS control used	–
d.17	Heating control	–	–	–	0 = Flow temperature 1 = Return temperature (adjustment for underfloor heating. If you have activated the return temperature control, the automatic heat output determination function is not active.)	0
d.18	Pump overrun operating mode	1	3	–	1 = Comfort (continuously operating pump) 3 = Eco (pump runs intermittently)	3
d.20	Maximum target domestic hot water temperature	50	55	°C	Increment = 1	55
d.21	Status of the warm start for domestic hot water	Current value		–	This function is displayed by the warm start is not actually available for this product. OF is permanently displayed since the function is deactivated. on = function is activated and available	–
d.22	Status of the DHW demand	Current value		–	OF = No current requirement on = Current requirement	–
d.23	Status of the heat demand	Current value		–	OF = Heating off (Summer mode) on = Heating on	–
d.27	Function of relay 1 (multi-functional module)	1	10	–	1 = Circulation pump 2 = External pump 3 = Cylinder charging pump 4 = Extraction hood 5 = External solenoid valve	1
d.28	Function of relay 2 (multi-functional module)	1	10	–	6 = Fault message 7 = Solar pump (omitted) 8 = eBUS remote control 9 = Anti-legionella pump 10 = Solar valve	2
d.33	Fan speed target value	Current value		rpm	Fan speed = Display value x 1000	–

Code	Parameter	Values		Unit	Increment, select, explanation	Factory setting
		Min.	Max.			
d.34	Value for the fan speed	Current value		rpm	Fan speed = Display value x 1000	–
d.35	3-port valve position	Current value		–	0 = Heating 40 = Mid-position (frost protection or filling) Hi = Domestic hot water	–
d.36	Value for the domestic hot water flow rate	Current value		l/min	–	–
d.39	Water temperature in the solar circuit	Current value		°C	The water temperature in the solar circuit is then only displayed if an optional solar set has been installed.	–
d.40	Heating flow temperature	Current value		°C	–	–
d.41	Heating return temperature	Current value		°C	–	–
d.43	Heat curve	0.2	4	K	Consult the accessory's operating instructions in order to implement this setting.	1.2
d.45	Base point of the heat curve	15	30	°C	Consult the accessory's operating instructions in order to implement this setting.	20
d.47	Outdoor temperature	Current value		°C	–	–
d.50	Correction of the minimum fan speed	0	2500	rpm	Increment = 100 Fan speed = Display value x 1000	600 (0.6 x 1000)
d.51	Correction of the maximum fan speed	-2500	0	rpm	Increment = 100 Fan speed = Display value x 1000 (flashing)	-1000 (1.0 x 1000)
d.58	Solar circuit post-heating	0	3	–	Applies to: Installed solar set (optional) 0 = Product's anti-legionella function deactivated 3 = Domestic hot water activated (min. target value 55 °C)	0
d.60	Number of blocks by the temperature cut-out (limit temperature)	Current value		–	If the value is greater than 99, the display shows the number alternately. Example using the number 1581: The display repeatedly shows the sequence 15 → 81 → __.	–
d.61	Number of unsuccessful ignitions	Current value		–		–
d.62	Day/set-back function	0	30	K	Increment = 1	0
d.64	Average burner ignition time	Current value		s	–	–
d.65	Maximum burner ignition time	Current value		s	–	–
d.67	Remaining burner anti-cycling time (setting under d.02)	Current value		min	–	–
d.68	Number of unsuccessful ignitions at 1st attempt	Current value		–	If the value is greater than 99, the display shows the number alternately.	–
d.69	Number of unsuccessful ignitions at 2nd attempt	Current value		–	Example using the number 1581: The display repeatedly shows the sequence 15 → 81 → __.	–
d.71	Maximum target heating flow temperature	30	75	°C	Increment = 1	75
d.80	Running time in heating mode	Current value		h	Running time = Display value x 1000	–
d.81	Running time in domestic hot water mode	Current value		h	Running time = Display value x 1000	–
d.82	Number of burner ignitions in heating mode	Current value		–	Number of ignitions = Display value x 1000	–
d.83	Number of burner ignitions in domestic hot water mode	Current value		–	Number of ignitions = Display value x 1000	–
d.85	Increase in the min. output (heating and domestic hot water mode)	–	–	kW	Increment = 1	–
d.88	Flow rate limit value for ignition in domestic hot water mode	0	1	–	0 = 1.5 l/min (no delay) 1 = 3.7 l/min (2 s delay)	0

Code	Parameter	Values		Unit	Increment, select, explanation	Factory setting
		Min.	Max.			
d.90	Status of the eBUS room thermostat	Current value		–	0 = Not connected 1 = Connected	–
d.93	Setting the product code	0	99	–	Increment = 1 The Device Specific Number (DSN) can be found on the data plate.	–
d.94	Delete fault list	0	1	–	0 = No 1 = Yes	–
d.96	Factory reset	0	1	–	0 = No 1 = Yes	–

C Status codes



Note

Since the code table is used for various products, some codes may not be visible for the product in question.

Statuscode	Meaning
S.00	Heating has no heat demand. The burner is off.
S.01	The fan start-up for heating mode is activated.
S.02	The pump prerun for heating mode is activated.
S.03	The ignition for heating mode is activated.
S.04	The burner for heating mode is activated.
S.05	The pump and fan overrun for heating mode is activated.
S.06	The fan overrun for heating mode is activated.
S.07	The pump overrun for heating mode is activated.
S.08	The anti-cycling time for heating mode is activated.
S.10	The domestic hot water demand is activated.
S.11	The fan start-up for domestic hot water mode is activated.
S.13	The ignition for domestic hot water mode is activated.
S.14	The burner for domestic hot water mode is activated.
S.15	The pump and fan overrun for domestic hot water mode is activated.
S.16	The fan overrun for domestic hot water mode is activated.
S.17	The pump overrun for domestic hot water mode is activated.
S.20	The domestic hot water demand is activated.
S.21	The fan start-up for domestic hot water mode is activated.
S.23	The ignition for domestic hot water mode is activated.
S.24	The burner for domestic hot water mode is activated.
S.25	The pump and fan overrun for domestic hot water mode is activated.
S.26	The fan overrun for domestic hot water mode is activated.
S.27	The pump overrun for domestic hot water mode is activated.
S.28	The burner anti-cycling time for domestic hot water mode is activated.
S.30	Room thermostat blocks heating mode.
S.31	The summer mode is activated or the eBUS control is blocking the heating mode.
S.32	The waiting period for the fan start-up is activated.
S.34	The frost protection function is activated.
S.39	"Burner off contact" has triggered (e.g. surface-mounted thermostat or condensate pump)
S.41	The system pressure is too high.
S.42	Flue non-return flap return signal blocks burner operation (only in conjunction with the multi-functional module) or condensate pump defective, heat demand is blocked.
S.46	Comfort protection mode for flame loss at minimum load is activated.

Statuscode	Meaning
S.53	The product is within the waiting period of the modulation block/operating block function as a result of low water pressure/water deficiency (flow/return spread too large).
S.54	Waiting period: No water in the system, flow/return sensor temperature increase too high.
S.58	The burner's modulation limit or the function for the siphon filling is activated
S.76	A service message is activated. Check the water pressure.
S.88	The purge programme is active.
S.91	The exhibition mode is activated.
S.96	The self-test for the return temperature sensor is activated. Heat demands are blocked.
S.98	The self-test for the flow/return temperature sensor is activated. Heat demands are blocked.

D Fault codes



Note

Since the code table is used for various products, some codes may not be visible for the product in question.

Message	Possible cause	Measure
F.00 Flow temperature sensor interruption	Plug for flow temperature sensor loose/not plugged in	▶ Check the plug and the plug connection for the flow temperature sensor.
	Flow temperature sensor defective	▶ Replace the flow temperature sensor.
	Multiple plug loose/not plugged in	▶ Check the multiple plug and plug connection.
	Interruption in the cable harness	▶ Check the cable harness.
F.01 Return temperature sensor interruption	Plug for return temperature sensor loose/not plugged in	▶ Check the plug and the plug connection for the return temperature sensor.
	Return temperature sensor defective	▶ Replace the return temperature sensor.
	Multiple plug loose/not plugged in	▶ Check the multiple plug and plug connection.
	Interruption in the cable harness	▶ Check the cable harness.
F.10 Flow temperature sensor short circuit	Flow temperature sensor defective	▶ Replace the flow temperature sensor.
	Short circuit in the cable harness	▶ Check the cable harness.
	Flow temperature sensor cable defective	▶ Check the flow temperature sensor cable.
F.11 Return temperature sensor short circuit	Return temperature sensor defective	▶ Replace the return temperature sensor.
	Short circuit in the cable harness	▶ Check the cable harness.
	Return temperature sensor cable defective	▶ Check the return temperature sensor cable.
F.13 Cylinder temperature sensor short circuit	Cylinder temperature sensor defective	▶ Replace the cylinder temperature sensor.
	Short circuit in the cable harness	▶ Check the cable harness.
	Short circuit in the connection cable	▶ Check the connection cable and, if required, replace it.
F.20 Temperature cut-out safety shutdown	Flow temperature sensor defective	▶ Replace the flow temperature sensor.
	Return temperature sensor defective	▶ Replace the return temperature sensor.
	Earth connection faulty	▶ Check the earth connection.
	Black discharge via the ignition cable, ignition plug or ignition electrode	▶ Check the ignition cable, ignition plug and ignition electrode.

Message	Possible cause	Measure
F.22 System pressure too low	Insufficient/no water in the product.	▶ Fill the heating installation. (→ Page 27)
	Water pressure sensor defective	▶ Replace the water pressure sensor.
	Interruption in the cable harness	▶ Check the cable harness.
	Cable for the pump/for the water pressure sensor is loose/not connected/defective	▶ Check the cable for the pump/for the water pressure sensor.
F.23 Safety switch-off: Temperature difference too great	Pump blocked	▶ Check that the pump is working correctly.
	Air in the product	▶ Purge the heating installation.
	Pump runs with insufficient output	▶ Check that the pump is working correctly.
	Flow and return temperature sensor connection inverted	▶ Check the connection for the flow and return temperature sensor.
F.24 Safety switch-off: Temp. incr. too fast	Pump blocked	▶ Check that the pump is working correctly.
	Pump runs with insufficient output	▶ Check that the pump is working correctly.
	Air in the product	▶ Purge the heating installation.
	System pressure too low	▶ Check the system pressure.
	Non-return valve blocked	▶ Check that the non-return valve is working correctly.
	Non-return valve installed incorrectly	▶ Check the installation location of the non-return valve.
F.25 Safety shutdown: Flue gas temperature too high	Flue gas safety cut-out plug is not plugged in or is loose	▶ Check the plug and the plug connection.
	Interruption in the cable harness	▶ Check the cable harness.
F.27 Safety switch-off: Flame simulation	Moisture on the PCB	▶ Check that the PCB works correctly.
	PCB defective	▶ Replace the PCB.
	Gas solenoid valve not leak-tight	▶ Check that the gas solenoid valve works correctly.
F.28 Ignition unsuccessful	Gas isolator cock closed	▶ Open the gas isolator cock.
	Gas meter defective	▶ Replace the gas meter.
	The gas pressure monitor has been triggered	▶ Check the gas flow pressure.
	Air in the gas supply (e.g. during initial start-up)	▶ Reset the unit once.
	Gas flow pressure too low	▶ Check the gas flow pressure.
	The thermal isolator device has been triggered	▶ Check the thermal isolator device.
	Condensate discharge pipe blocked	▶ Check the condensate discharge pipe.
	Incorrect replacement gas valve assembly	▶ Check the replacement gas valve assembly.
	Incorrect gas valve assembly offset	▶ Check the offset setting for the gas valve assembly.
	Gas valve assembly defective	▶ Check the gas valve assembly.
	Multiple plug loose/not plugged in	▶ Check the multiple plug and plug connection.
	Interruption in the cable harness	▶ Check the cable harness.
	Ignition system defective	▶ Replace the ignition system.
	Earthing defective	▶ Check the product's earthing.
	Electronics defective	▶ Check the PCB.
	Air/flue pipe blocked	▶ Check the air/flue pipe.
Restrictor for the reference pressure pipe blocked	▶ Check the condition of the restrictor on the gas valve assembly's reference pressure pipes.	
F.29 Ignition and check faults during operation – flame has gone out	The gas supply is interrupted	▶ Check the gas supply.
	Incorrect flue gas recirculation	▶ Check the flue gas recirculation.

Message	Possible cause	Measure
F.29 Ignition and check faults during operation – flame has gone out	Earthing defective	▶ Check the product's earthing.
	Ignition misfire	▶ Check that the ignition transformer works correctly.
	Condensate discharge pipe blocked	▶ Check the condensate discharge pipe.
	Air/flue pipe blocked	▶ Check the air/flue pipe.
	Reference pressure pipe not connected	<ol style="list-style-type: none"> 1. Check whether the reference pressure pipe is connected between the gas valve assembly and the restrictor for the reference pressure pipe. 2. Check whether the reference pressure pipe is connected between the restrictor for the reference pressure pipe and the distribution pipe.
F.32 Fan fault	Plug on fan not plugged in or is loose	▶ Check the plug on the fan and the plug connection.
	Multiple plug loose/not plugged in	▶ Check the multiple plug and plug connection.
	Interruption in the cable harness	▶ Check the cable harness.
	Fan blocked	▶ Check that the fan works correctly.
	Hall sensor defective	▶ Replace the Hall sensor.
	Electronics defective	▶ Check the PCB.
F.33 Excessive pressure losses from the air/flue system	Air/flue pipe blocked or partially blocked	▶ Check the entire air/flue pipe.
	Fan defective	▶ Check that the fan works correctly.
	PCB defective	▶ Replace the PCB.
	Temperature sensors defective or not connected correctly	▶ Ensure that the electrical connection for the temperature sensors has been established correctly, that they are not corroded, and that they click into place correctly on the connecting piece.
	CO ₂ content too low	<p>▶ Check the CO₂ setting and, if required, increase the CO₂ content while taking the tolerances into consideration. (→ Page 33)</p> <p>▽ If the increase in the CO₂ content is not sufficient, set diagnostics code d.85 to 10.</p>
	Presence of a shunt pump in the circuit	▶ This product is not compatible with a shunt pump in the installation; remove the shunt pump and change the installation's basic diagram accordingly.
	Excessive counter-pressure in the air/flue pipe	▶ If required, protect the product (wind deflector).
F.46 Cold water sensor short circuit	Cold water sensor defective	▶ Replace the cold water sensor.
	Short circuit in the cable harness	▶ Check the cable harness.
F.49 Fault: eBUS	Short circuit in the eBUS connection	▶ Check that the eBUS connection works correctly.
	eBUS overload	▶ Check that the eBUS connection works correctly.
	Different polarities at the eBUS connection	▶ Check that the eBUS connection works correctly.
F.61 Fault: Fuel control valve	Short circuit in the cable harness for the gas valve assembly	▶ Check the cable harness for the gas valve assembly.
	Gas valve defective	▶ Replace the gas valve.
	PCB defective	▶ Replace the PCB.
F.62 Fault: Delayed shutdown of the fuel control valve	Gas valve defective	▶ Replace the gas valve.
	PCB defective	▶ Replace the PCB.
	Ignition electrode defective	▶ Replace the ignition electrode.
F.63 Fault: EEPROM	PCB defective	▶ Replace the PCB.
F.64 Fault: Electronics/temperature sensor	Flow temperature sensor short circuit	▶ Check that the flow temperature sensor works correctly.
	Return temperature sensor short circuit	▶ Check that the return temperature sensor works correctly.

Message	Possible cause	Measure
F.64 Fault: Electronics/temperature sensor	PCB defective	▶ Replace the PCB.
F.65 Electronics temperature fault	Electronics overheated	▶ Check the external heat effects on the electronics.
	PCB defective	▶ Replace the PCB.
F.67 Fault: Electronics/flame	Implausible flame signal	▶ Check the flame signal.
	PCB defective	▶ Replace the PCB.
	Fault in the flue gas route	▶ Check the entire flue gas route.
F.68 Fault: Unstable flame signal	Air in the gas supply (e.g. during initial start-up)	▶ Reset the unit once.
	Gas flow pressure too low	▶ Check the gas flow pressure.
	Incorrect air ratio	▶ Check the CO ₂ content at the flue gas analysis point.
	Incorrect flue gas recirculation	▶ Check the flue gas recirculation.
F.70 Invalid device specific number (DSN)	Device Specific Number not set/is incorrect	▶ Set the correct Device Specific Number.
F.71 Flow temperature sensor fault	The flow temperature sensor signals a constant value	▶ Check the positioning of the flow temperature sensor.
	Flow temperature sensor in the incorrect position	▶ Check the positioning of the flow temperature sensor.
	Flow temperature sensor defective	▶ Replace the flow temperature sensor.
F.72 Fault: Return temperature sensor	Flow temperature sensor defective	▶ Replace the flow temperature sensor.
	Return temperature sensor defective	▶ Replace the return temperature sensor.
F.73 Water pressure sensor signal in the wrong range (too low)	Short circuit in the cable harness	▶ Check the cable harness.
	Interruption in the cable harness	▶ Check the cable harness.
	Water pressure sensor defective	▶ Replace the water pressure sensor.
F.74 Water pressure sensor signal outside correct range (too high)	Short circuit in the cable harness	▶ Check the cable harness.
	Interruption in the cable harness	▶ Check the cable harness.
	Water pressure sensor defective	▶ Replace the water pressure sensor.
F.76 Fault: Thermal cut-out	Defective thermal fuse	▶ Check the heat exchanger for leakages. If the heat exchanger has no leaks, bypass the thermal fuse. If you can then start the product, replace the thermal fuse.
F.77 Fault: Flue non-return flap/condensate pump	No feedback from the flue non-return flap or the feedback is incorrect	▶ Check that the flue non-return flap functions correctly.
	Flue non-return flap defective	▶ Replace the flue non-return flap.
	Condensate pump defective	▶ Replace the condensate pump.
F.78 Interruption: Domestic hot water outlet temperature sensor with external control	NTC sensor defective	▶ Replace the NTC sensor.
F.83 Fault: NTC temperature fluctuation	System pressure too low	▶ Check the system pressure.
	Flow temperature sensor: No contact	▶ Check whether the flow temperature sensor is lying against the flow pipe correctly.
	Return temperature sensor: No contact	▶ Check whether the return temperature sensor is lying against the return pipe correctly.
	Insufficient/no water in the product.	▶ Fill the heating installation. (→ Page 27)

Message	Possible cause	Measure
F.84 NTC temperature difference is implausible	Flow temperature sensor installed incorrectly	▶ Check whether the flow temperature sensor has been installed correctly.
	Return temperature sensor installed incorrectly	▶ Check whether the return temperature sensor has been installed correctly.
	Flow and return temperature sensors inverted	▶ Check whether the flow and return temperature sensor has been installed correctly.
F.85 Flow and return temperature sensors have been installed incorrectly (inverted)	Flow/return temperature sensors have been installed on the same pipe/wrong pipe	▶ Check that the flow and return temperature sensors have been installed on the correct pipe.
F.86 External safety shutdown	Limit thermostat settings incorrect	▶ Check the limit thermostat settings.
	The flow temperature sensor measures deviating values	▶ Check the flow temperature sensor.
	3-port diverter valve blocked	▶ Check the 3-port diverter valve.
	Condensate pump defective	▶ Replace the condensate pump.
F.87 Fault: Igniter	Igniter not connected	▶ Check the igniter's connection.
	Igniter connected incorrectly	▶ Check the igniter's connection.
	Short circuit in the cable harness	▶ Check the cable harness.
F.88 Fault: Gas valve assembly	Gas valve assembly not connected	▶ Check the connection to the gas valve assembly.
	Gas valve assembly connected incorrectly	▶ Check the connection to the gas valve assembly.
	Short circuit in the cable harness	▶ Check the cable harness.
F.89 Fault: Pump	Pump not connected	▶ Check the pump connection.
	Pump connected incorrectly	▶ Check the pump connection.
	Incorrect pump connected	▶ Check whether the pump that is connected is the one that is recommended for the product.
	Short circuit in the cable harness	▶ Check the cable harness.
F.97 Main PCB self-test failed	PCB defective	▶ Replace the PCB.

E Check programmes



Note

Since the code table is used for various products, some codes may not be visible for the product in question.

Check programme	Meaning
P.00 Purging the domestic hot water and heating circuit	The function is activated in the small domestic hot water circuit for 4 minutes and then in the heating circuit for 1 minute. The pump runs and stops at regular intervals. The function is active for five minutes.
P.01 Start up the burner at the adjustable heat input in heating mode	Following successful ignition, the product is operated at the heat input shown in the display. This value can be set from 0% (0 = min. output) to 100% (Hi = max. output) using \ominus and \oplus . The function is active for 15 minutes.
P.03 Start up the burner at partial load	Following successful ignition, the product is operated at the partial heat load that is set using diagnostics code d.00 . The function is active for 15 minutes.
P.04 Chimney sweep function	If there is a domestic hot water demand, the product runs in domestic hot water mode and at maximum heat input. If there is no domestic hot water demand, the product runs in heating mode with the partial heat load that is set using diagnostics code d.00 . The function is active for 15 minutes.
P.08 Filling or draining the product	The prioritising diverter valve is moved to the mid-position. To fill or drain the product, the burner and pump are switched off. The function is active for 15 minutes.

F Wiring diagram

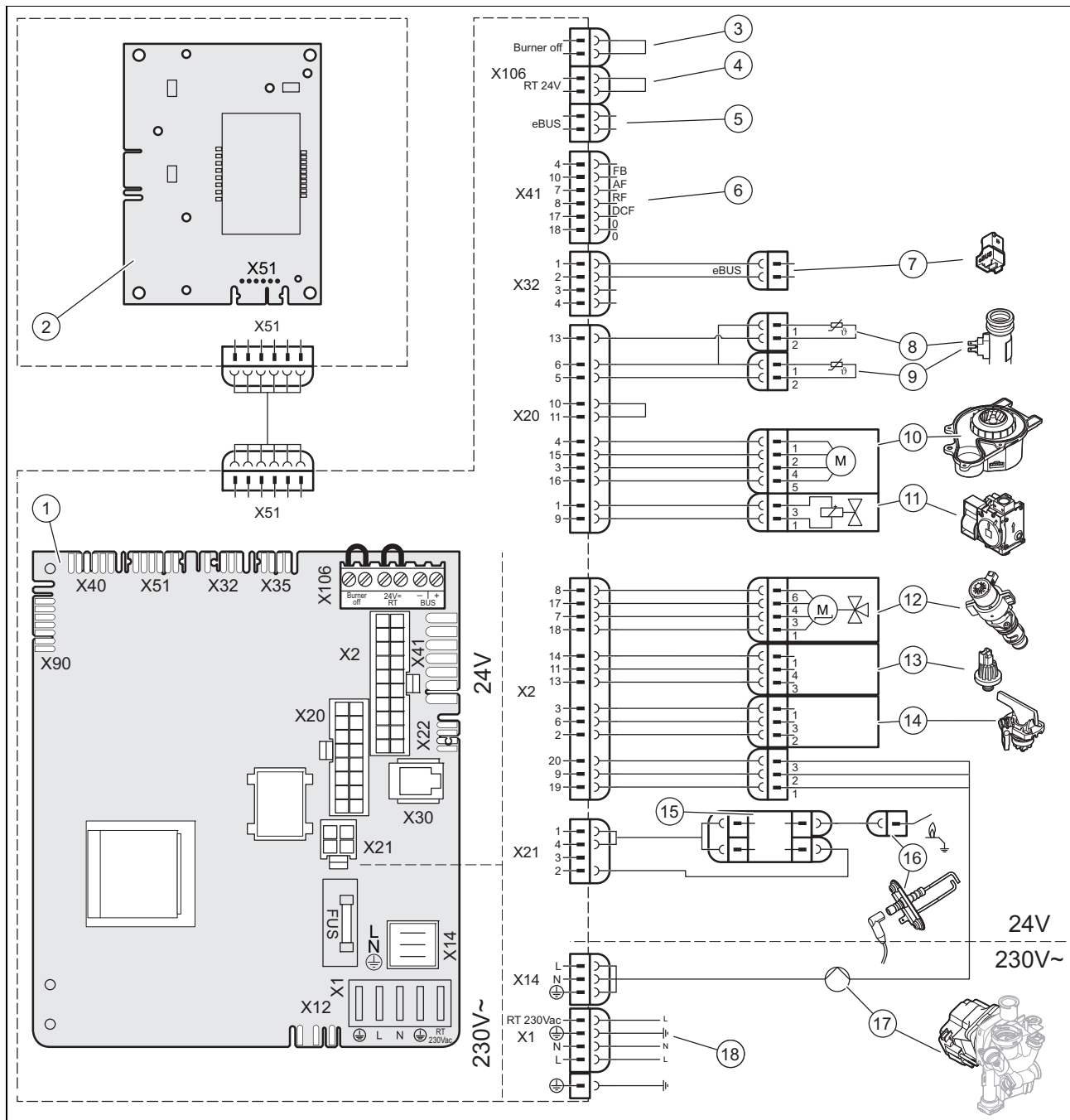

- | | | | |
|---|---|----|-----------------------------------|
| 1 | Main PCB | 8 | Heating flow temperature sensor |
| 2 | PCB for the control element | 9 | Heating return temperature sensor |
| 3 | Limit thermostat with contact for underfloor heating, <i>Burner off</i> (optional) | 10 | Fan |
| 4 | Room thermostat, <i>RT 24 V</i> (optional) | 11 | Gas valve assembly |
| 5 | Bus connection for control/room thermostat (optional) | 12 | Prioritising diverter valve |
| 6 | Outdoor temperature sensor, flow temperature sensor (external), DCF receiver (optional) | 13 | Water pressure sensor |
| 7 | External <i>eBUS</i> plug | 14 | Water flow switch |
| | | 15 | Igniter |
| | | 16 | Ignition electrode |
| | | 17 | Pump |
| | | 18 | Main power supply |

G Commissioning Checklist

Benchmark Commissioning & Warranty Validation Service Record

It is a requirement that the boiler is installed and commissioned to the manufacturers' instructions and the data fields on the commissioning checklist completed in full.

To instigate the boiler warranty the boiler needs to be registered with the manufacturer within one month of the installation. The warranty rests with the end-user (consumer), and they should be made aware it is ultimately their responsibility to register with the manufacturer, within the allotted time period.

It is essential that the boiler is serviced in line with the manufacturers' recommendations, at least annually. This must be carried out by a competent Gas Safe registered engineer. The service details should be recorded on the Benchmark Service and Interim Boiler Work Record and left with the householder. Failure to comply with the manufacturers' servicing instructions and requirements will invalidate the warranty.



www.hhic.co.uk

This Commissioning Checklist is to be completed in full by the competent person who commissioned the boiler as a means of demonstrating compliance with the appropriate Building Regulations and then handed to the customer to keep for future reference.

Failure to install and commission according to the manufacturers' instructions and complete this Benchmark Commissioning Checklist will invalidate the warranty. This does not affect the customer's statutory rights.

* All installations in England and Wales must be notified to Local Authority Building Control (LABC) either directly or through a Competent Persons Scheme. A Building Regulations Compliance Certificate will then be issued to the customer.

© Heating and Hotwater Industry Council (HHIC)



www.centralheating.co.uk

GAS BOILER SYSTEM COMMISSIONING CHECKLIST & WARRANTY VALIDATION RECORD

Address:															
Boiler make and model:															
Boiler serial number:															
Commissioned by (PRINT NAME):						Gas Safe registration number:									
Company name:						Telephone number:									
Company email:						Company address:									
										Commissioning date:					
Heating and hot water system complies with the appropriate Building Regulations?											Yes				
Optional: Building Regulations Notification Number (if applicable):															
Time, temperature control and boiler interlock provided for central heating and hot water											Yes				
Boiler Plus requirements (tick the appropriate box(s))															
Boiler Plus option chosen for combination boiler in ENGLAND						Weather compensation		Smart thermostat with automation and optimisation							
						Load compensation		Flue Gas Heat Recovery							
Time and temperature control to hot water		Cylinder thermostat and programmer/timer						Combination boiler							
Zone valves		pre-existing		Fitted		Not required									
Thermostatic radiator valves		pre-existing		Fitted		Not required									
Automatic bypass to system		pre-existing		Fitted		Not required									
Underfloor heating		pre-existing		Fitted		Not required									
Water quality															
The system has been flushed, cleaned and a suitable inhibitor applied upon final fill, in accordance with BS7593 and boiler manufacturers' instructions											Yes				
What system cleaner was used?						Brand:		Product:							
What inhibitor was used?						Brand:		Product:							
Primary water system filter		pre-existing		Fitted		Not required									
CENTRAL HEATING MODE measure and record (as appropriate)															
Gas rate (for combination boilers complete DHW mode gas rate)				m ³ /hr		or		ft ³ /hr							
Central heating output left at factory settings?											Yes	No			
If no, what is the maximum central heating output selected?											kW				
Dynamic gas inlet pressure											mbar				
Central heating flow temperature											°C				
Central heating return temperature											°C				
System correctly balanced/rebalanced?											Yes				
COMBINATION BOILERS ONLY															
Is the installation in a hard water area (above 200ppm)?											Yes	No			
Water scale reducer/softener		pre-existing		Fitted		Not required									
What type of scale reducer/softener has been fitted?						Brand:		Product:							
Water meter fitted?											Yes	No			
If yes- DHW expansion vessel		pre-existing		Fitted		Not required									
Pressure reducing valve		pre-existing		Fitted		Not required									
DOMESTIC HOT WATER MODE Measure and record															
Gas rate				m ³ /hr		or		ft ³ /hr							
Dynamic gas inlet pressure at maximum rate											mbar				
Cold water inlet temperature											°C				
Hot water has been checked at all outlets											Yes	Temperature	°C		
CONDENSATE DISPOSAL															
The condensate drain has been installed in accordance with the manufacturers' instructions and/or BS5546/BS6798											Yes				
Point of termination						Internal		External (only where internal termination impractical)							
Method of disposal						Gravity		Pumped							
ALL INSTALLATIONS															
Record the following		At max rate:		CO		ppm		CO ₂		%		CO/CO ₂		Ratio	
		At min rate (where possible)		CO		ppm		CO ₂		%		CO/CO ₂		Ratio	
Where possible, has a flue integrity check been undertaken in accordance with manufacturers' instructions, and readings are correct?											Yes				
The operation of the boiler and system controls have been demonstrated to and understood by the customer											Yes				
The manufacturers' literature, including Benchmark Checklist and Service Record, has been explained and left with the customer											Yes				
Commissioning Engineer's signature															
Customer's signature (To confirm satisfactory demonstration and receipt of manufacturers' literature)															

* All installations in England and Wales must be notified to Local Authority Building Control (LABC) either directly or through a Competent Persons Scheme. A Building Regulations Compliance Certificate will then be issued to the customer.

© Heating and Hotwater Industry Council (HHIC)



www.centralheating.co.uk

SERVICE & INTERIM BOILER WORK RECORD

It is recommended that your boiler and heating system are regularly serviced and maintained, in line with manufacturers' instructions, and that the appropriate service / interim work record is completed.

Service provider

When completing a service record (as below), please ensure you have carried out the service as described in the manufacturers' instructions. Always use the manufacturers' specified spare parts.

SERVICE/INTERIM WORK ON BOILER <small>delete as appropriate</small> Date:				
Engineer name:		Company name:		
Telephone N°:		Gas Safe registration N°:		
Max rate	CO	ppm	CO ₂	% CO/CO ₂
Min rate	CO	ppm	CO ₂	% CO/CO ₂
Where possible, has a flue integrity check been undertaken in accordance with manufacturers' instructions, and readings are correct?*				yes
Gas rate:	m ³ /h	OR	ft ³ /h	
Were parts fitted? <small>delete as appropriate</small>	Yes	No		
Parts fitted:				
System inhibitor concentration has been checked and appropriate action taken, in accordance with BS 7593 and boiler manufacturers' instructions. *				yes n/a
Comments:				
Signature:				

*A System inhibitor efficacy test is required on every annual service in accordance with the manufacturers' instructions and BS 7593. It is only acceptable to not have undertaken this if the service engineers attendance visit was in between annual services to attend a non-water facing component.

SERVICE/INTERIM WORK ON BOILER <small>delete as appropriate</small> Date:				
Engineer name:		Company name:		
Telephone N°:		Gas Safe registration N°:		
Max rate	CO	ppm	CO ₂	% CO/CO ₂
Min rate	CO	ppm	CO ₂	% CO/CO ₂
Where possible, has a flue integrity check been undertaken in accordance with manufacturers' instructions, and readings are correct?*				yes
Gas rate:	m ³ /h	OR	ft ³ /h	
Were parts fitted? <small>delete as appropriate</small>	Yes	No		
Parts fitted:				
System inhibitor concentration has been checked and appropriate action taken, in accordance with BS 7593 and boiler manufacturers' instructions. *				yes n/a
Comments:				
Signature:				

*A System inhibitor efficacy test is required on every annual service in accordance with the manufacturers' instructions and BS 7593. It is only acceptable to not have undertaken this if the service engineers attendance visit was in between annual services to attend a non-water facing component.

SERVICE/INTERIM WORK ON BOILER <small>delete as appropriate</small> Date:				
Engineer name:		Company name:		
Telephone N°:		Gas Safe registration N°:		
Max rate	CO	ppm	CO ₂	% CO/CO ₂
Min rate	CO	ppm	CO ₂	% CO/CO ₂
Where possible, has a flue integrity check been undertaken in accordance with manufacturers' instructions, and readings are correct?*				yes
Gas rate:	m ³ /h	OR	ft ³ /h	
Were parts fitted? <small>delete as appropriate</small>	Yes	No		
Parts fitted:				
System inhibitor concentration has been checked and appropriate action taken, in accordance with BS 7593 and boiler manufacturers' instructions. *				yes n/a
Comments:				
Signature:				

*A System inhibitor efficacy test is required on every annual service in accordance with the manufacturers' instructions and BS 7593. It is only acceptable to not have undertaken this if the service engineers attendance visit was in between annual services to attend a non-water facing component.

SERVICE/INTERIM WORK ON BOILER <small>delete as appropriate</small> Date:				
Engineer name:		Company name:		
Telephone N°:		Gas Safe registration N°:		
Max rate	CO	ppm	CO ₂	% CO/CO ₂
Min rate	CO	ppm	CO ₂	% CO/CO ₂
Where possible, has a flue integrity check been undertaken in accordance with manufacturers' instructions, and readings are correct?*				yes
Gas rate:	m ³ /h	OR	ft ³ /h	
Were parts fitted? <small>delete as appropriate</small>	Yes	No		
Parts fitted:				
System inhibitor concentration has been checked and appropriate action taken, in accordance with BS 7593 and boiler manufacturers' instructions. *				yes n/a
Comments:				
Signature:				

*A System inhibitor efficacy test is required on every annual service in accordance with the manufacturers' instructions and BS 7593. It is only acceptable to not have undertaken this if the service engineers attendance visit was in between annual services to attend a non-water facing component.

SERVICE/INTERIM WORK ON BOILER <small>delete as appropriate</small> Date:				
Engineer name:		Company name:		
Telephone N°:		Gas Safe registration N°:		
Max rate	CO	ppm	CO ₂	% CO/CO ₂
Min rate	CO	ppm	CO ₂	% CO/CO ₂
Where possible, has a flue integrity check been undertaken in accordance with manufacturers' instructions, and readings are correct?*				yes
Gas rate:	m ³ /h	OR	ft ³ /h	
Were parts fitted? <small>delete as appropriate</small>	Yes	No		
Parts fitted:				
System inhibitor concentration has been checked and appropriate action taken, in accordance with BS 7593 and boiler manufacturers' instructions. *				yes n/a
Comments:				
Signature:				

*A System inhibitor efficacy test is required on every annual service in accordance with the manufacturers' instructions and BS 7593. It is only acceptable to not have undertaken this if the service engineers attendance visit was in between annual services to attend a non-water facing component.

SERVICE/INTERIM WORK ON BOILER <small>delete as appropriate</small> Date:				
Engineer name:		Company name:		
Telephone N°:		Gas Safe registration N°:		
Max rate	CO	ppm	CO ₂	% CO/CO ₂
Min rate	CO	ppm	CO ₂	% CO/CO ₂
Where possible, has a flue integrity check been undertaken in accordance with manufacturers' instructions, and readings are correct?*				yes
Gas rate:	m ³ /h	OR	ft ³ /h	
Were parts fitted? <small>delete as appropriate</small>	Yes	No		
Parts fitted:				
System inhibitor concentration has been checked and appropriate action taken, in accordance with BS 7593 and boiler manufacturers' instructions. *				yes n/a
Comments:				
Signature:				

*A System inhibitor efficacy test is required on every annual service in accordance with the manufacturers' instructions and BS 7593. It is only acceptable to not have undertaken this if the service engineers attendance visit was in between annual services to attend a non-water facing component.

* All installations in England and Wales must be notified to Local Authority Building Control (LABC) either directly or through a Competent Persons Scheme. A Building Regulations Compliance Certificate will then be issued to the customer.

© Heating and Hotwater Industry Council (HHIC)



www.centralheating.co.uk

SERVICE & INTERIM BOILER WORK RECORD

It is recommended that your boiler and heating system are regularly serviced and maintained, in line with manufacturers' instructions, and that the appropriate service / interim work record is completed.

Service provider

When completing a service record (as below), please ensure you have carried out the service as described in the manufacturers' instructions. Always use the manufacturers' specified spare parts.

SERVICE/INTERIM WORK ON BOILER <small>delete as appropriate</small>					Date:
Engineer name:		Company name:			
Telephone N°:		Gas Safe registration N°:			
Max rate	CO	ppm	CO ₂	%	CO/CO ₂
Min rate	CO	ppm	CO ₂	%	CO/CO ₂
Where possible, has a flue integrity check been undertaken in accordance with manufacturers' instructions, and readings are correct?"					yes
Gas rate:	m ³ /h	OR	ft ³ /h		
Were parts fitted? <small>delete as appropriate</small>		Yes	No		
Parts fitted:					
System inhibitor concentration has been checked and appropriate action taken, in accordance with BS 7593 and boiler manufacturers' instructions. *					yes n/a
Comments:					
Signature:					

*A System inhibitor efficacy test is required on every annual service in accordance with the manufacturers' instructions and BS 7593. It is only acceptable to not have undertaken this if the service engineers attendance visit was in between annual services to attend a non-water facing component.

SERVICE/INTERIM WORK ON BOILER <small>delete as appropriate</small>					Date:
Engineer name:		Company name:			
Telephone N°:		Gas Safe registration N°:			
Max rate	CO	ppm	CO ₂	%	CO/CO ₂
Min rate	CO	ppm	CO ₂	%	CO/CO ₂
Where possible, has a flue integrity check been undertaken in accordance with manufacturers' instructions, and readings are correct?"					yes
Gas rate:	m ³ /h	OR	ft ³ /h		
Were parts fitted? <small>delete as appropriate</small>		Yes	No		
Parts fitted:					
System inhibitor concentration has been checked and appropriate action taken, in accordance with BS 7593 and boiler manufacturers' instructions. *					yes n/a
Comments:					
Signature:					

*A System inhibitor efficacy test is required on every annual service in accordance with the manufacturers' instructions and BS 7593. It is only acceptable to not have undertaken this if the service engineers attendance visit was in between annual services to attend a non-water facing component.

SERVICE/INTERIM WORK ON BOILER <small>delete as appropriate</small>					Date:
Engineer name:		Company name:			
Telephone N°:		Gas Safe registration N°:			
Max rate	CO	ppm	CO ₂	%	CO/CO ₂
Min rate	CO	ppm	CO ₂	%	CO/CO ₂
Where possible, has a flue integrity check been undertaken in accordance with manufacturers' instructions, and readings are correct?"					yes
Gas rate:	m ³ /h	OR	ft ³ /h		
Were parts fitted? <small>delete as appropriate</small>		Yes	No		
Parts fitted:					
System inhibitor concentration has been checked and appropriate action taken, in accordance with BS 7593 and boiler manufacturers' instructions. *					yes n/a
Comments:					
Signature:					

*A System inhibitor efficacy test is required on every annual service in accordance with the manufacturers' instructions and BS 7593. It is only acceptable to not have undertaken this if the service engineers attendance visit was in between annual services to attend a non-water facing component.

SERVICE/INTERIM WORK ON BOILER <small>delete as appropriate</small>					Date:
Engineer name:		Company name:			
Telephone N°:		Gas Safe registration N°:			
Max rate	CO	ppm	CO ₂	%	CO/CO ₂
Min rate	CO	ppm	CO ₂	%	CO/CO ₂
Where possible, has a flue integrity check been undertaken in accordance with manufacturers' instructions, and readings are correct?"					yes
Gas rate:	m ³ /h	OR	ft ³ /h		
Were parts fitted? <small>delete as appropriate</small>		Yes	No		
Parts fitted:					
System inhibitor concentration has been checked and appropriate action taken, in accordance with BS 7593 and boiler manufacturers' instructions. *					yes n/a
Comments:					
Signature:					

*A System inhibitor efficacy test is required on every annual service in accordance with the manufacturers' instructions and BS 7593. It is only acceptable to not have undertaken this if the service engineers attendance visit was in between annual services to attend a non-water facing component.

SERVICE/INTERIM WORK ON BOILER <small>delete as appropriate</small>					Date:
Engineer name:		Company name:			
Telephone N°:		Gas Safe registration N°:			
Max rate	CO	ppm	CO ₂	%	CO/CO ₂
Min rate	CO	ppm	CO ₂	%	CO/CO ₂
Where possible, has a flue integrity check been undertaken in accordance with manufacturers' instructions, and readings are correct?"					yes
Gas rate:	m ³ /h	OR	ft ³ /h		
Were parts fitted? <small>delete as appropriate</small>		Yes	No		
Parts fitted:					
System inhibitor concentration has been checked and appropriate action taken, in accordance with BS 7593 and boiler manufacturers' instructions. *					yes n/a
Comments:					
Signature:					

*A System inhibitor efficacy test is required on every annual service in accordance with the manufacturers' instructions and BS 7593. It is only acceptable to not have undertaken this if the service engineers attendance visit was in between annual services to attend a non-water facing component.

SERVICE/INTERIM WORK ON BOILER <small>delete as appropriate</small>					Date:
Engineer name:		Company name:			
Telephone N°:		Gas Safe registration N°:			
Max rate	CO	ppm	CO ₂	%	CO/CO ₂
Min rate	CO	ppm	CO ₂	%	CO/CO ₂
Where possible, has a flue integrity check been undertaken in accordance with manufacturers' instructions, and readings are correct?"					yes
Gas rate:	m ³ /h	OR	ft ³ /h		
Were parts fitted? <small>delete as appropriate</small>		Yes	No		
Parts fitted:					
System inhibitor concentration has been checked and appropriate action taken, in accordance with BS 7593 and boiler manufacturers' instructions. *					yes n/a
Comments:					
Signature:					

*A System inhibitor efficacy test is required on every annual service in accordance with the manufacturers' instructions and BS 7593. It is only acceptable to not have undertaken this if the service engineers attendance visit was in between annual services to attend a non-water facing component.

* All installations in England and Wales must be notified to Local Authority Building Control (LABC) either directly or through a Competent Persons Scheme. A Building Regulations Compliance Certificate will then be issued to the customer.

© Heating and Hotwater Industry Council (HHIC)



www.centralheating.co.uk

H Commissioning Flow Chart

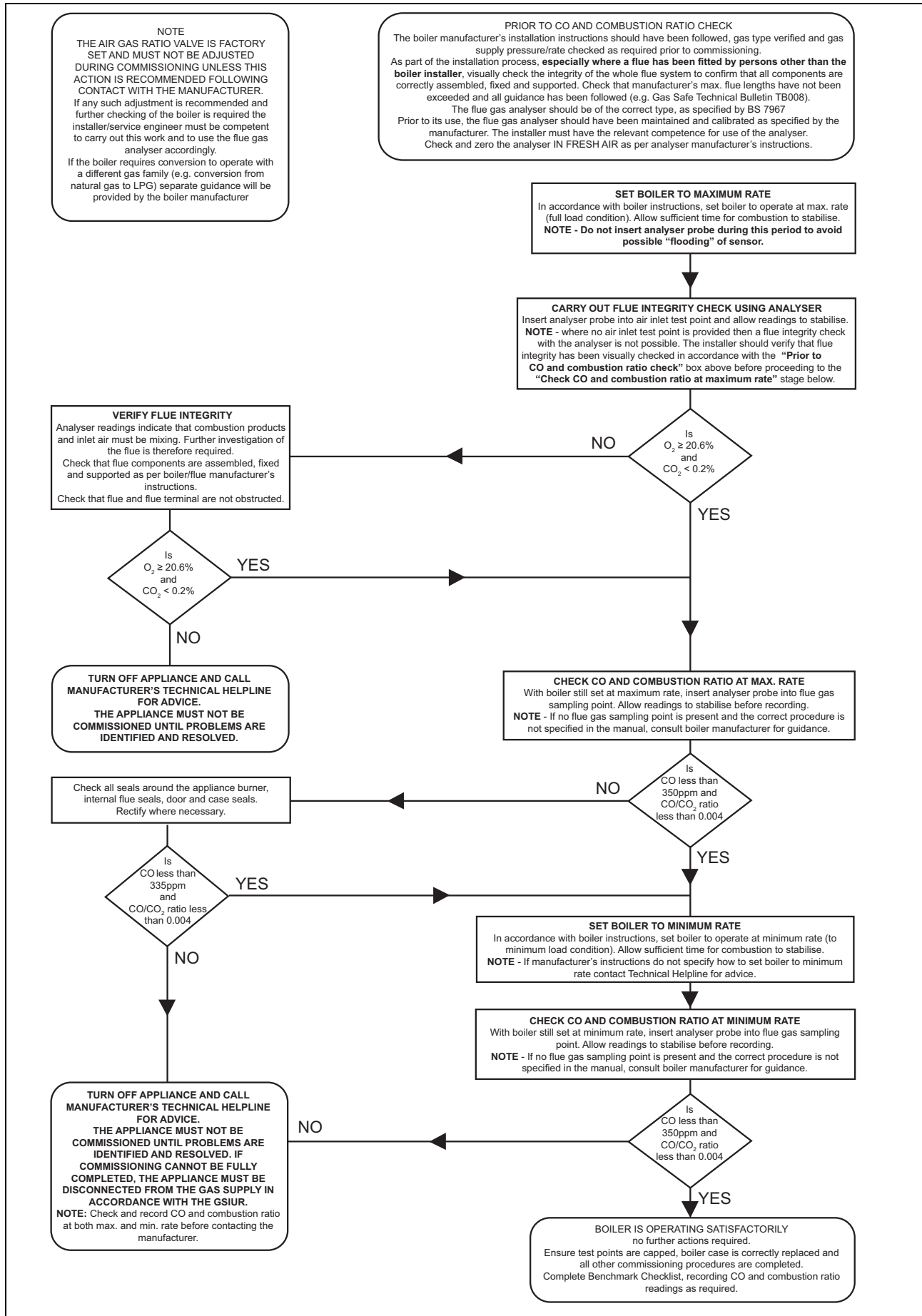

Index

A		
Air ratio setting	29	
Article number	9	
B		
Burner anti-cycling time	30	
Burner flange, insulating mat	36	
C		
Calling up a check programme	25	
Calling up a diagnostics code	25	
Calling up status codes	25	
Calling up the fault memory	39	
Calling up the installer level	25	
CE marking	9	
Check programmes	39	
Checking the burner	36	
Checking the CO ₂ content	29	
Checking the components	34	
Checking the gas connection pressure	28	
Checking the gas flow pressure	28	
Checking the gas setting	27	
Checking the insulating mat	35	
Checking the pre-charge pressure of the expansion vessel	37	
Cleaning the components	34	
Cleaning the heat exchanger	36	
Cleaning, heating filter	38	
Combustion area, insulating mat	36	
Completing cleaning work	38	
Completing inspection work	38–39	
Completing maintenance work	39	
Completing repair work	40	
Condensate siphon	21, 38	
Connecting the air/flue pipe	21	
Connecting the control	23	
D		
Disposal	41	
Domestic hot water temperature	32	
Drain pipe	21	
Draining the product	39	
E		
Exiting the installer level	25	
Expansion relief valve	21	
F		
Fault messages	39	
Filling and purging the product	27	
Filling the condensate siphon with water	19	
Filling the expansion vessel	37	
G		
Garantie	6	
Gas group	18	
Gas type	18	
H		
Handing over to the end user	32	
Heating filter, cleaning	38	
Heating flow temperature	32	
I		
If you smell gas	3	
Inspection	33	
Installing the air/flue pipe	21	
Installing the compact thermal module	36	
Installing the front casing	17	
Installing the gas connection	19	
Installing the heating flow	19	
Installing the heating return	19	
Insulating mat, burner flange	36	
Insulating mat, combustion area	35	
Intended use	3	
K		
Kammerbelüftung	11	
Kundendienst	6	
L		
Leak-tightness	30	
M		
Maintenance	33	
Minimum clearances around the product	11	
O		
Opening the electronics box	22	
P		
Packaging, disposing of	41	
Permanently decommissioning	41	
Power supply	23	
Preparing for maintenance work	34	
Preparing the cleaning work	34	
Preparing the repair work	39	
Product dimensions	11	
Purging	27	
R		
Regulations	5	
Removing the compact thermal module	35	
Removing/installing the front casing	17	
Replacing components	39	
Replacing the fan	40	
Replacing the gas valve assembly	40	
Replacing the pump	40	
S		
Scale	32	
Scale deposition	32	
Scope of delivery	11	
Serial number	9	
Setting a diagnostics code	25	
Setting the bypass valve	31	
Setting the pump curve	31	
Spare parts	39	
Switching off	41	
Switching off the product	41	
Switching on the product	27	
T		
Technical data	7	
Treating the heating water	26	
W		
Weight	17	

Manufacturer/Supplier

Vaillant Group UK LTD

Nottingham Road – Belper-Derbyshire – DE56 1JQ

Telephone 01773 824639 – Technical helpline 0330 100 7679

After sales service 0330 100 3142

www.glow-worm.co.uk

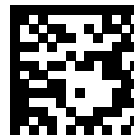

0020289288_03

0020289288_03 – 14.10.2020

© These instructions, or parts thereof, are protected by copyright and may be reproduced or distributed only with the manufacturer's written consent.
Subject to technical modifications.