

Installation & Servicing Instructions

To be left with the user

INSET BBU 50

G.C. No. 44 047 02

For Use Only With Specially Designed Fire Fronts

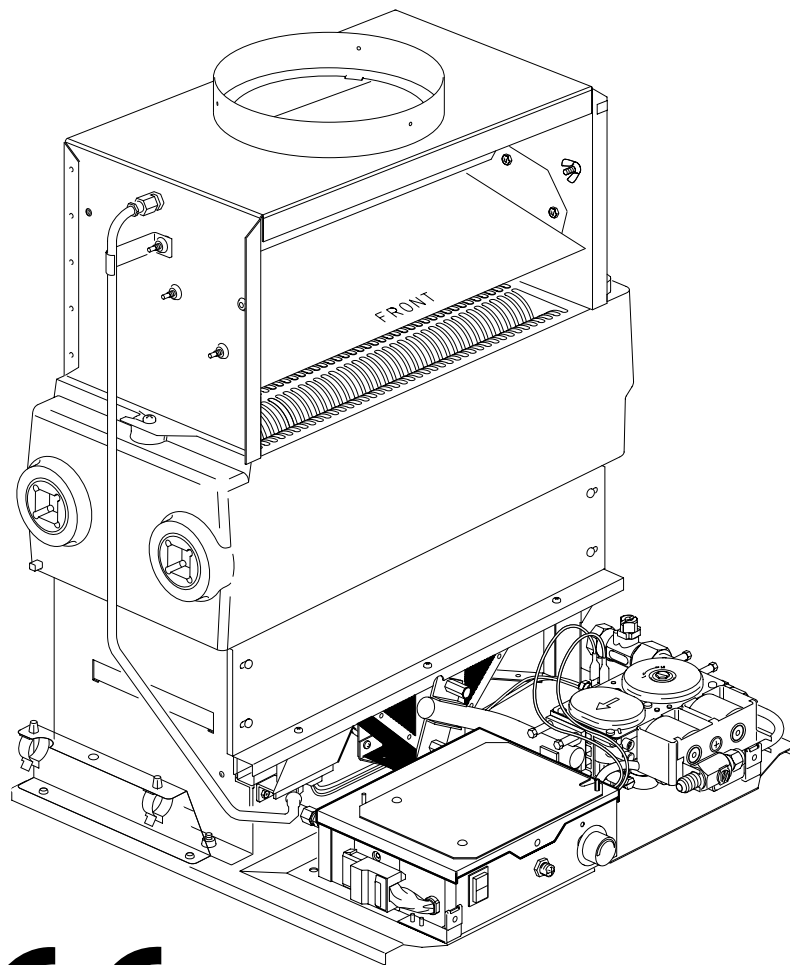

This is a Cat I_{2H} Appliance

HEATCALL

One Contact Local Service

Customer Services:

Tel: (01773) 828100

Fax: (01773) 828070

Hepworth Heating Ltd.,

Nottingham Road, Belper, Derbyshire. DE56 1JT

General/Sales enquiries:

Tel: (01773) 824141 Fax: (01773) 820569

Important Information

B.S.I Certification

It is important that no alteration is made to the boiler without permission, in writing, from Hepworth Heating Ltd.

Any alteration that is not approved by Hepworth Heating Ltd., could invalidate the B.S.I. Certification, the boiler warranty and could also infringe the current issue of the Statutory Requirements, see Section 1.1.

CE Mark

The boiler meets the requirements of Statutory Instrument, No. 3083 The Boiler (Efficiency) Regulations, and therefore is deemed to meet the requirements of Directive 92/42 EEC on the efficiency requirements for new hot water boilers fired with liquid or gaseous fuels.

Type test for purposes for Regulation 5 certified by: Notified body 0086.

Product/production certified by: Notified by 0086.

1. Directive 90/396/EEC on the approximation of the Laws of the Member States relating to appliances burning gaseous fuels.
2. Directive 73/23/EEC on the harmonization of the Laws of the Member States relating to electrical equipment designed for use within certain voltage limits.
3. Directive 89/336/EEC on the approximation of the Laws of the Member States relating to electromagnetic compatibility.

INFORMATION FOR THE INSTALLER AND SERVICE ENGINEER.

Under Section 6 of The Health and Safety at Work Act 1974, we are required to provide information on substances hazardous to health.

The adhesives and sealants used in this appliance are cured and give no known hazard in this state.

RADIANTS, FUELBEDS, ARTIFICIAL FUEL

After handling wash hands thoroughly.

INSULATION PADS/CERAMIC FIBRE, GLASSYARN, MINERAL WOOL

These can cause irritation to skin, eyes and the respiratory tract.

If you have a history of skin complaint you may be susceptible to irritation. High dust levels are usual only if the material is broken.

Normal handling should not cause discomfort, but follow normal good hygiene and wash your hands before eating, drinking or going to the lavatory.

If you do suffer irritation to the eyes or severe irritation to the skin seek medical attention.

THERMOSTATS

These contain very small amounts of trichlorofluoromethane in the sealed phial and capillary. If broken, under normal circumstances the fluid does not cause a problem, but it can, in exceptional cases cause freeze burns.

If there is skin burn or irritation to the eyes or skin seek medical attention.

These contain very small amounts of xylene in the sealed phial and capillary. If broken, under normal circumstances the fluid does not cause a problem, but in cases of skin contact, wash with cold water.

If swallowed drink plenty of water and seek medical attention.

CUT-OFF DEVICES

These contain a very small amount of ethylene glycol and methanol in the capillary. If broken, under normal circumstances the fluid does not cause a problem, but in cases of skin or eye contact, wash with cold water.

If swallowed drink plenty of water and seek medical attention.

CONTENTS	DESCRIPTION	SECTION	PAGE No.
INSTALLATION INSTRUCTIONS	General Data	1	3
	Types of Installation	2	6
	Flue and Ventilation	3	7
	Installation	4	8
	Electrical Wiring	5	13
	Commissioning	6	16
	Fire Installation	7	18
SERVICING INSTRUCTIONS	Servicing	8	18
	Fault Finding	9	22
	Replacement Parts	10	24
	Spare Parts	11	28

1 General

1 General

References in these instructions to British Standards, Statutory Regulations and Requirements apply only to the United Kingdom.

For Ireland the rules in force must be used.

The instructions consist of three parts, Installation and Servicing Instructions for the Back Boiler Unit, Installation and Servicing Instructions for the specified Fire Front and Instructions for Use and the Guarantee Registration Card. The instructions are an integral part of the appliance and must, to comply with the current issue of The Gas Safety (Installation and Use) Regulations, be handed to the user on completion of the installation.

The Glow-worm Inset 50 Back Boiler Unit, GC No. 44 047 02 is for use only with the Glow-worm Inset Fire Fronts.

1 General Notes and Information

IMPORTANT NOTICE

This boiler is for use only on G20 gas.

The back boiler unit is fitted with a flue blockage safety device which will shut it down if there is a lack of oxygen resulting from a build up of combustion products, the flame on the pilot light will become unstable and lift up off the thermocouple. This will deactivate the mag unit in the gas control valve, cutting off the gas supply.

If the back boiler unit shuts down frequently for no apparent reason the first things to check are the chimney and air inlets into the room. Any problems found must be put right, by a competent person, and a full operational test carried out before the fire is used again.

The flue blockage safety device incorporates the electrode, thermocouple and pilot assemblies.

The flue blockage safety device MUST NOT be adjusted or disconnected. It must be serviced strictly in accordance with the instructions in this book. Any unauthorised interference could result in the device failing to operate, creating a potentially dangerous situation. If replacing, use only the correct and approved parts.

Wherever possible, all materials, appliances and components to be used shall comply with the requirements of applicable British Standards.

Where no British Standard exists, materials and equipment should be fit for their purpose and of suitable quality and workmanship.

This boiler, together with its fire can be used on a precast flue, see Section 3.4.

Sheet Metal Parts

WARNING. When installing or servicing this back boiler care should be taken when handling the edges of sheet metal parts to avoid any possibility of personal injury.

1.1 Statutory Requirements

The installation of this back boiler unit must be carried out by a competent person in accordance with the current issue and relevant requirements of:

Manufacturer's instructions, supplied.

The Gas Safety (Installation and Use) Regulations, The Building Regulations, The Building Standards (Scotland) Regulations, applicable in Scotland, Local Gas Undertaking, Bye-laws of the Local Water Company, The Health and Safety at Work Act, Control of Substances Hazardous to Health, The Electricity at Work Regulations and any applicable local regulations.

Detailed recommendations are contained in the current issue of the following British Standard codes of practice,

BS1251, BS5440 Part 1 and 2, BS5449, BS5546, BS5871, BS6798, BS6891, BS7593, BS7671.

Manufacturer's notes must not be taken as overriding statutory obligations.

1.2 Data BBU 50

Gas connection	Rc $\frac{1}{2}$ ($\frac{1}{2}$ inBSPT)
Water connection	Supplied in fittings pack
Electrical supply	230V~50Hz fused 3A
Weight, about	40kg (81.6lb)
Water content	3.11Litres (0.68gall)
Injector	3.5mm

Dimensions, except as noted, shown on diagrams are in millimetres.

Data Label: On the base of the boiler next to the electrical control box.

The Seasonal Efficiency Domestic Boilers UK (SEDBUK) is 76.8%.

The value is used in the UK Government's Standard Assessment Procedure (SAP) for energy rating of dwellings. The test data from which it has been calculated have been certified by B.S.I.

1.3 Gas Supply

The gas installation must be in accordance with the current issue of BS6891.

The supply from the governed gas meter must be of adequate size to provide a steady inlet working pressure of 20mbar (8in wg) at the boiler.

On completion test the gas installation for soundness using the pressure drop method and suitable leak detection fluid, purge in accordance with the above standard.

1.4 Electrical Supply

WARNING. This boiler must be earthed.

All system components shall be of an approved type and shall be connected in accordance with the current issue of BS7671 and any applicable local regulations.

Connection of the boiler and system controls to the mains supply should be through a common isolator, a double pole isolating switch, fused 3A, should be used, having a minimum contact separation of 3mm in both poles.

Alternatively, a fused 3A 3pin plug and unswitched shuttered socket both to the current issue of BS1363 may be used.

Wiring to the boiler must be PVC (85°C) insulated type to the current issue of BS6500 Table 9, not less than 0.75mm² (24/0.20mm).

1 General

6173

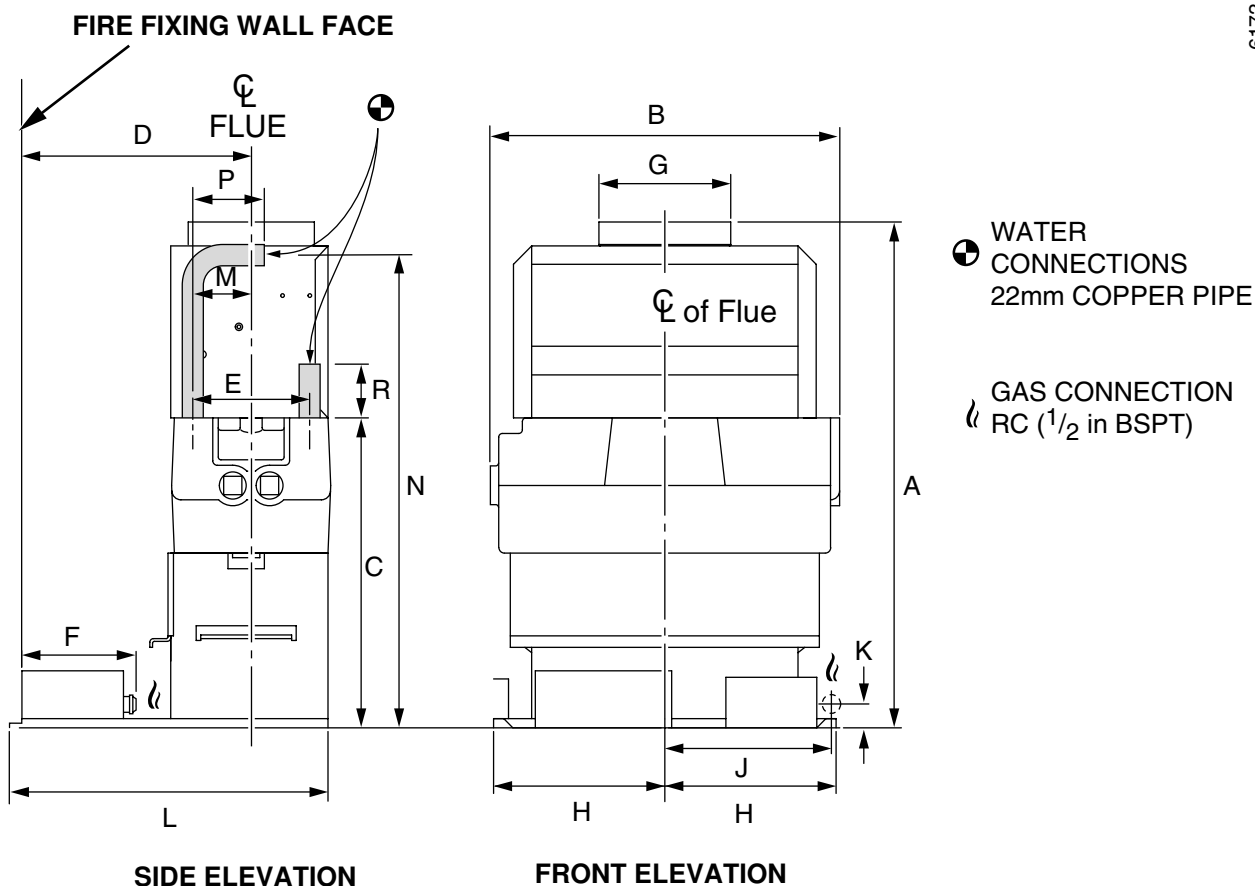

DIMENSION	A	B	C	D	E	F	G	H	J	K	L	M	N	P	R
50 / BBU	550	400	337	245	130	164	146	193	174	39	348	65	530	80	50

OVERALL DIMENSIONS
(RIGHT HAND WATER CONNECTION SHOWN)

Diagram 1.1

TABLE 1
INSET BBU 50
RANGE RATING

Glow-worm		HEPWORTH HEATING LTD., BELPER, DERBYS. DE56 1JT		
INSET BBU 50		453560		
ELECTRICAL SUPPLY: 230V ~ 50Hz 8W Fused at 3A For use on Nat. gas (G20) only Supply pressure 20 mbar		GC No. 44 047 02 CE 0086 GB IE 0086/AS/055		
SERIAL No.		INJECTOR: 3.5mm 203002		
RANGE RATING		MIN	MID	MAX
HEAT INPUT	kW	15.1	16.5	18.3
	Btu/h	51500	56250	62350
HEAT OUTPUT	kW	11.7	13.2	14.7
	Btu/h	40000	45000	50000
HOT BURNER PRESSURE	mbar	9.7	11.2	13.6
	in wg	3.8	4.5	5.5
Position ↑ against setting		Cat. I _{2H} EN437		

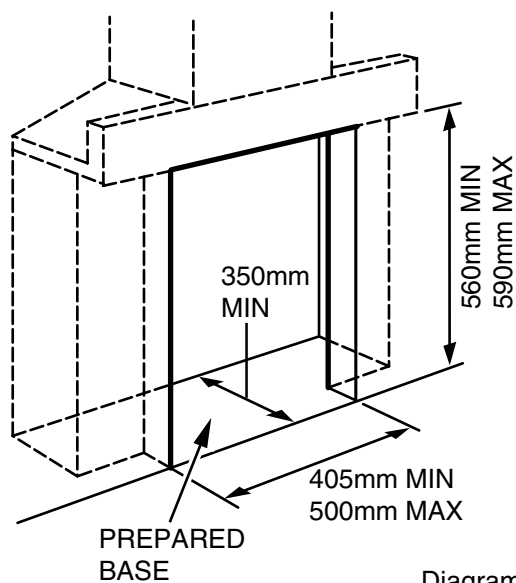

Diagram 1.2

6302

1 General

1.5 Contents of Packaging

The boiler is delivered in one pack which contains all the parts required for installation.

1.6 Site Requirements

For all types of installation a standard 16inch builder's opening is required, see diagram 1.2.

Note: The depth of the fire opening is IMPORTANT, it MUST therefore conform to the dimensions given in diagram 1.2.

Any larger opening will need to be reduced, with non-combustible material to conform to this requirement.

It is important that the opening is cleared of debris and mortar etc.

The prepared base for the back boiler must be level.

Refer to diagram 1.3 for dimensions of the fire fixing wall face which MUST be true.

1.7 Water System - Open Vented

This boiler can be used on an unrestricted open vented system with the water supply taken from a feed and expansion cistern, having a head between 1m (3ft 3in) minimum and 27m (90ft) maximum.

Diagrammatic layouts of systems are shown in diagram 1.4 and 1.5.

Sealed Water System

A Kit and instructions, Part No. 459033, is available to enable the back boiler to be used on a sealed water system.

Please give the serial number of the back boiler unit when ordering the kit.

1.8 Hot Water Cylinder

The back boiler is suitable for open vented systems using an indirect cylinder (including single feed self priming type). The cylinder must be fitted to the manufacturer's recommendations and the system must conform to the requirements of the current issue of BS5449.

It is recommended that the cylinder be fitted with some form of temperature control.

1.9 Frost Protection

If the position of the boiler is such that it may be vulnerable to freezing it should be protected as specified in the current issue of BS5422.

It is also recommended that a frost thermostat is fitted.

1.10 Draining Tap

A draining tap must be provided at the lowest point of the system which will allow the entire system, the boiler and hot water cylinder to be drained.

Draining taps shall be to the current issue of BS2879.

1.11 Safety Valve

A safety valve need not be fitted to an open vented system.

1.12 Boiler Location

This back boiler unit MUST NOT be installed in a private garage or in a room containing a bath or shower or a room used or intended to be used as sleeping accommodation.

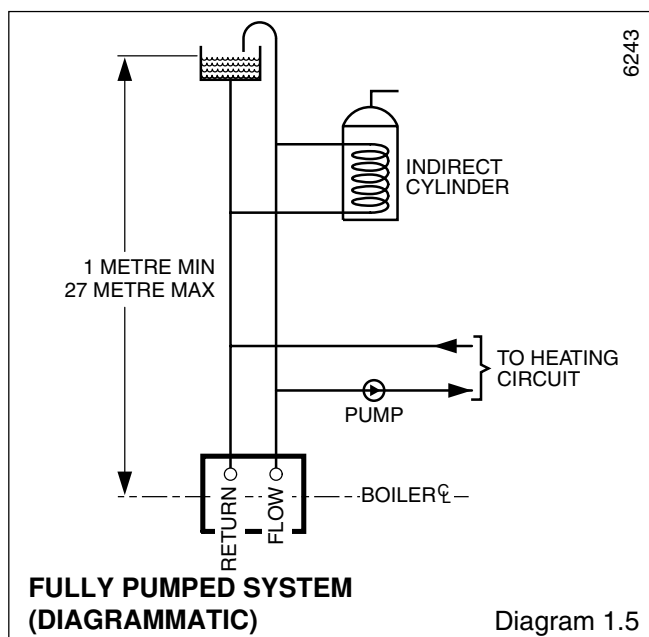
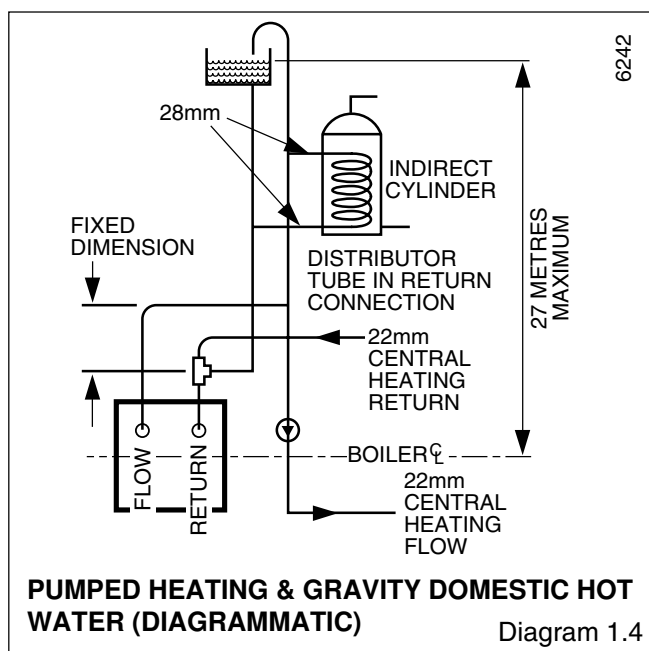
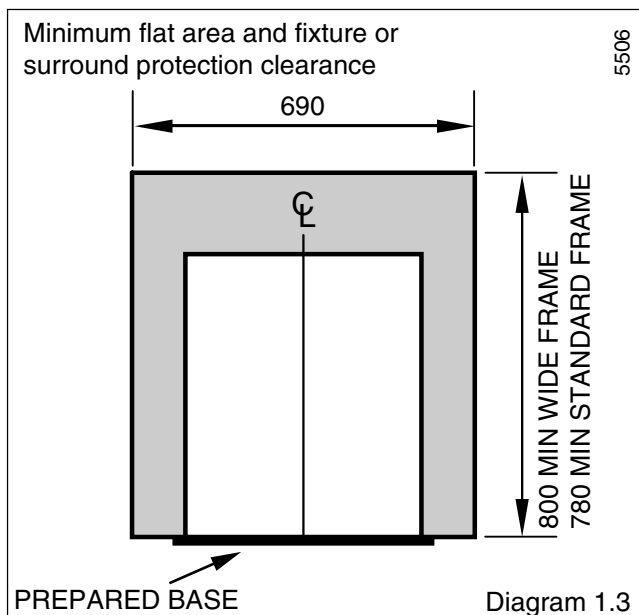

2 Types of Installation

2.1 Hearth

In ALL cases there MUST be a non-combustible hearth under the fire front.

For minimum dimensions of a hearth see diagram 2.1.

Carpet or similar floor covering must not be placed on the hearth.

If the boiler is to be mounted above the prepared hearth the hearth must still conform to the instructions above and the dimensions given in diagram 2.1.

2.2 Fire Surround

The combined thickness of the surround and the lintel must be checked, to ensure that the back boiler can be positioned within the opening to allow easy connection of the flue into the boiler flue socket, see diagram 2.2.

For fireplaces where the wall is not plastered and not covered by BS1251 it is important that such installations comply with the current issue of The Building Regulations.

Any combustible material, for example, blown vinyl wall coverings, on the fire fixing face area of the surround must be removed, see diagram 1.3.

2.3 Without Fire Surround

The builder's opening, with lintel must have minimum dimensions as shown in diagrams 1.2 and 2.2.

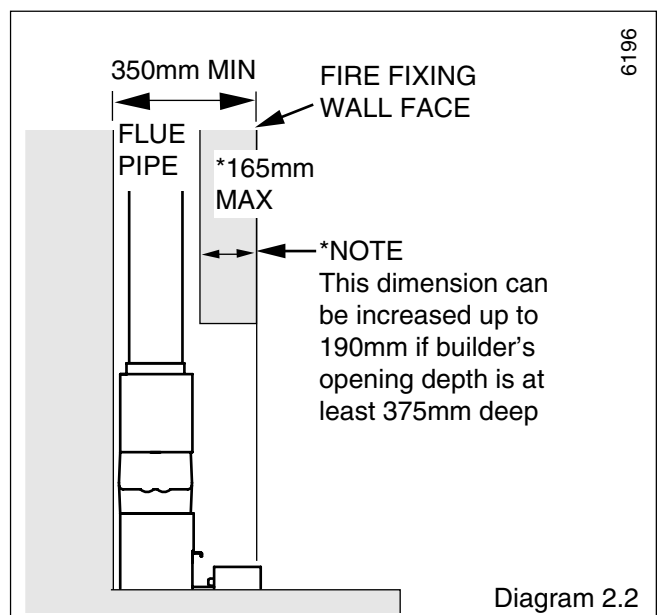
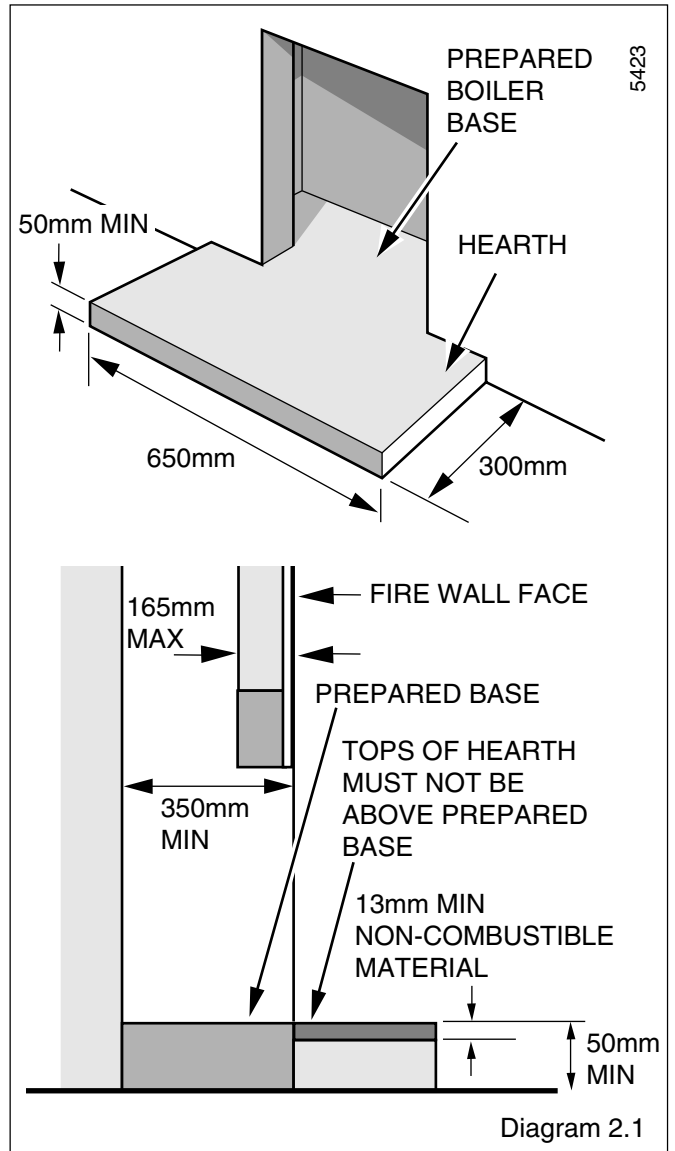

3 Flue and Ventilation

3.1 General

The general recommendations of the current issue of BS5440 Part 1 should be followed.

In all cases the flue should be lined, preferably with a flexible liner.

It is essential that the flue has an equivalent height of at least 2.5m (8.2ft) measured from the flue connection on the appliance. The first 600mm, at least, above the draught diverter must be vertical.

Where the installation is new it is essential to make sure that the annular space between the boiler flue liner and the chimney is sealed at the base and at the top of the chimney, as shown in diagram 3.2.

The flue socket is designed to take flue pipe to BS567. If flue pipe conforming to a different standard is used a suitable adapter must be fitted and secured to the flue socket. A flexible flue liner may be used, with connection to the back boiler flue socket, see diagram 3.1.

The existing flue may not be completely sound. Therefore, to prevent the possibility of leakage to an adjacent flue, additional sealing **MUST** be carried out between the base of the chimney and the flue liner.

The end of the flue liner at the chimney top must be adequately sealed and clamped, using proprietary fittings suitable for the flue liner used, see diagram 3.2.

The flue should, preferably, end above ridge height but at the least above the eaves of a pitched roof. Use a certificated terminal.

If the flue is to pass through or near any combustible material it should be installed in accordance with the current issue of BS5440 Part 1. If in doubt seek advice from the local gas undertaking or Hepworth Heating Ltd.

3.2 Existing Chimney

An existing brick chimney must be thoroughly swept and all debris cleared away before lining.

Remove any damper or register plate. Alternatively it may be locked in the open position,

A flexible flue liner is preferred but a rigid liner may be used, with connection to the back boiler flue socket made with a short vertical piece of flexible liner, see diagram 3.1.

Any air supply that enters the builder's opening other than by the front opening, that is underdraught openings and the like must be completely sealed off.

The sealing plate also prevents debris falling and gives the flue better insulation, reducing the possibility of condensation, see diagram 3.2.

Check the flue system efficiency before installing the back boiler.

3.3 New Chimney

A newly built chimney can be lined with a moisture resistant lining, such as salt glazed pipe, of an appropriate diameter as specified in the Building Regulations

In the case of a salt glazed lined flue, it is recommended that a short vertical length of flue pipe, preferably flexible metallic be used. Fix and seal it to the back boiler flue socket, make good with approved packing and parge with fire cement, see diagram 3.1.

If a flue and false chimney breast are to be constructed all openings for pipework to upper floors etc., must be sealed. The only opening for the back boiler must be at the front, being of the dimensions as shown in diagram 1.2.

If a specially built compartment is constructed for the back boiler, it must conform to the requirements of the current issue of BS5440 Part 1 and BS5871.

The flue should, preferably, end above ridge height but at least above the eaves of a pitched roof. Use a certificated terminal.

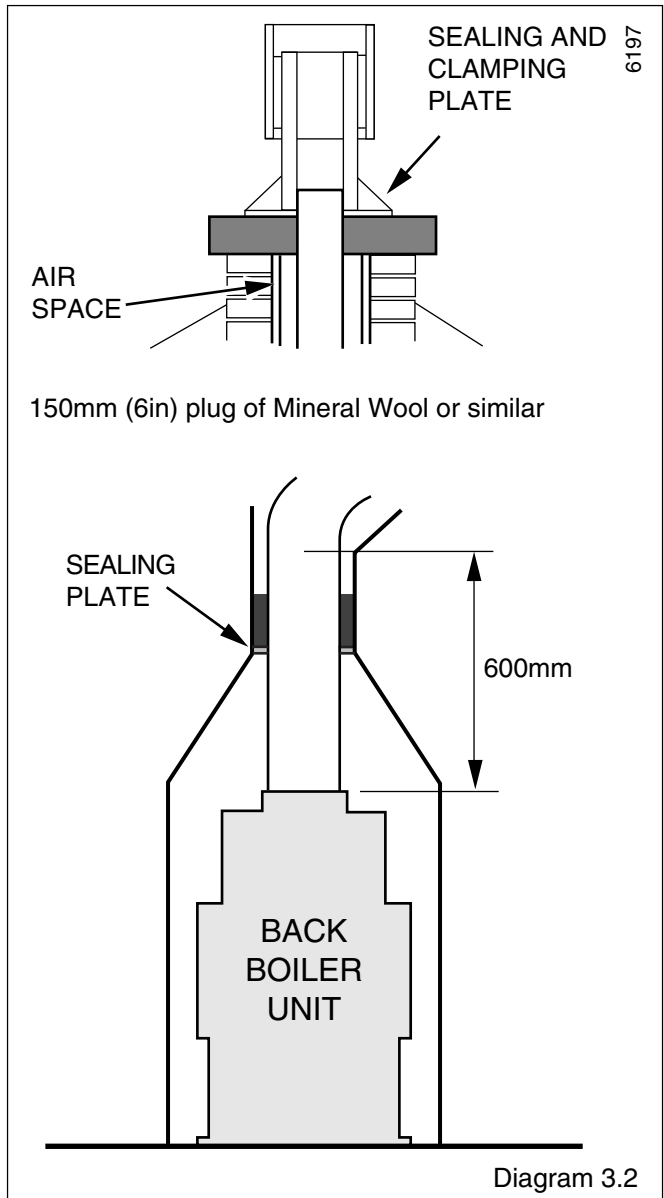
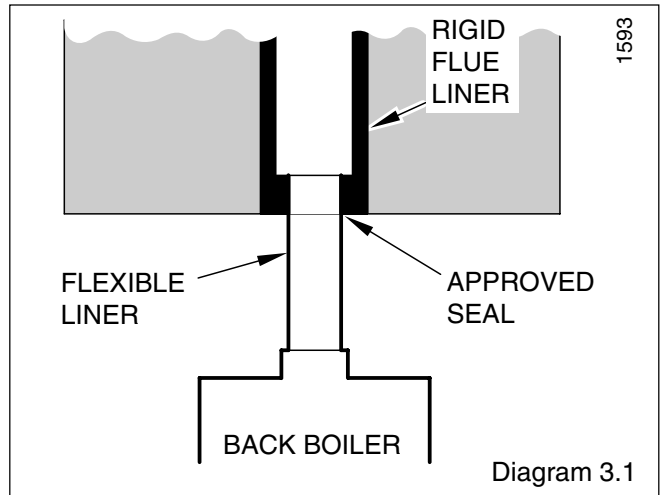

3 Flue and Ventilation

3.4 Precast Flue

The appliance is suitable for fitting to a properly constructed non-impeded precast flue.

Note: It is not recommended that this boiler is fitted to a pre-cast flue where plaster/rendering has been applied directly on to the face of the flue block as this could lead to high surface temperature and cracking of the plaster.

There must be a minimum vertical effective height of 3metres.

The flue cross sectional area must not be less than 198mmx97mm.

It is essential that the correct recess blocks, cover block and offset blocks suitable for back boiler units have been used.

A sealed connection must always be made between the boiler socket and the precast flue.

Note: It is possible, if this is a replacement, that the previous appliance may have been more tolerant in respect of flue requirements.

It is essential, therefore, as for ALL installations to make sure that there is no spillage of the products of combustion from this new appliance.

3.5 Ventilation - Back Boiler and Fire

The room in which the back boiler unit is installed must have adequate air inlets to ensure correct operation as specified in the current issue of BS5440 Part 2.

Ventilation requirement for the BBU 50 is 84cm² (13in²).

This ventilation area takes into account the total requirement of the back boiler unit and fire.

The ventilation openings may be direct to the outside air or with an internal room or space (such as a hall) which itself has a permanent air vent of the same effective area. The permanent air vent should be in a position which will cause the least nuisance to occupants, due to draughts.

This vent **MUST NOT** be placed in the builder's opening.

If the appliance is to be installed in a room already containing another fuel burning unit, the air supply required for this other unit **MUST** be added to the figure above.

Any air vent taken through a cavity wall must be ducted.

3.6 Extract Fans

If an extract fan is fitted in the premises, there is a possibility that if adequate air inlet openings are not provided spillage of the products of combustion could occur.

When openings are fitted in accordance with the recommendations of the current issue of BS5440 Part 2, extract fans should not cause spillage.

Where such a fan installation is found, a clearance of products test must be conducted as described in the fire front Installation Instructions, Section 4.5.

This test must be carried out with the back boiler fitted with its fire front.

See also Section 6.3 of these instructions.

Note: Refer again to Section 1.7 and diagram 1.2 and make sure that there is sufficient depth for the back boiler unit.

4 Installation

4.1 Preparation

Remove draught diverter, flueway baffles and fittings pack from carton.

Check contents of fittings pack against packed list.

Remove back boiler body assembly from carton.

4.2 Water Connections

IT IS EXTREMELY IMPORTANT THAT NO SERVICE PIPES ARE ROUTED IN FRONT OF THE BOILER. If the builder's opening was previously used for solid fuel all pipework within should be protected with PVC tape or equal. Pipework passing through walls of the opening should be sleeved and made good.

The two heat exchanger connections are supplied in the fittings pack and **MUST** be used, see diagram 4.1.

IMPORTANT: Make sure that the return pipe assembly is fitted the correct way, that is, the brazed joint must be positioned downward into the heat exchanger - remove label before fitting - see diagrams 4.1 and 4.4.

NOTE: Take care when soldering the copper connections not to damage the fibre washers.

4.3 Pumped Heating with Gravity Domestic Hot Water

NOTE: The draught diverter and capillaries are shown to aid plumbing, but would not be fitted at this stage.

All pipework must comply with the current issue of BS5546.

The domestic hot water flow and return pipes must be 28mm.

Refer to diagram 1.4 for a diagrammatic layout.

If it is necessary to route pipework from both sides of the builder's opening, it is recommended that the heat exchanger is positioned on the combustion chamber so that the gravity circuits exit on the same side as the boiler connections.

If the heat exchanger connections are opposite hand to that required, the heat exchanger can be turned, as follows, remove the four screws securing the heat exchanger to combustion chamber, see diagram 4.2. Turn heat exchanger, refit the four screws.

It is recommended that pumped heating connections are pre-piped as in diagram 4.4.

IMPORTANT: Make sure that the return pipe assembly is fitted the correct way, that is, the brazed joint must be positioned downward into the heat exchanger - remove label before fitting - see diagrams 4.1 and 4.4.

Note: The diagram 4.4 shows two methods "A" and "B" of plumbing the flow pipe.

The central heating return must have the injector fitted on both methods "A" and "B", see diagram 4.4 for fitting the injector.

4.4 Pumped Heating and Hot Water

NOTE: The draught diverter and capillaries are shown to aid plumbing, but would not be fitted at this stage.

Refer to diagram 1.5 for a diagrammatic layout.

If it is necessary to route pipework from both sides of the builder's opening it is recommended that the heat exchanger is positioned on the combustion chamber such that the flow pipe exits on the same side as the boiler connections.

It is recommended that the pumped return is pre-piped as in diagram 4.3.

4 Installation

If the heat exchanger connections are opposite hand to that required, turn in the same manner as described in Section 4.3 paragraph 5.

4.5 Heat Shield Assembly

If the boiler electrical supply cable has to be routed down the left hand side of the combustion chamber you must fit the heat shield assembly supplied in the fittings pack. Refer to Section 5.1 and diagrams 5.2 and 5.3.

4.6 Circulating Pump

Isolating valves, integral if possible, must be fitted each side of the circulating pump.

4.7 Gas Supply

The gas installation must be fitted in accordance with the recommendations of the current issue of BS6891.

Do not use pipe of a smaller diameter than Rc $\frac{1}{2}$ ($\frac{1}{2}$ BSP) inlet or 15mm, see diagram 1.1 for position of gas connection.

The gas meter must be capable of passing natural gas at the following rates: 49.5ft³/h to 82.1ft³/h (1.40m³/h to 2.32m³/h).

This rate is in addition to all other natural gas appliances supplied from the same meter.

It is recommended that the gas supply enters the builder's opening on the right hand side.

If the gas supply enters from the left hand side it will be necessary to route the pipe behind the combustion chamber before final fixing.

4.8 Positioning the Back Boiler

To position the back boiler lift by the heat exchanger casting and place centrally in the builder's opening. The installation centre line is indicated on the base by a notch on the front of the plate and the fire fixing wall face positioning line by the front corner edges of the base, see diagram 4.5.

The back boiler must be positioned so that a line across the opening of the fire fixing wall face coincides with the fire fixing wall face positioning line, see diagram 4.5. Use a straight edge across the fire fixing wall face to make sure that the back boiler is square to it.

Check that the back boiler is level. If packing is required to adjust the level of the back boiler, use metal shims and pack under the full width of the base.

Mark through the three fixing holes on the floor protection plate, see diagram 4.6. Remove the back boiler unit. Drill three holes using a 5mm masonry drill bit to accept the plugs and fixings provided.

4.9 Positioning the Back Boiler - continued

Fit the flueway baffles, ensuring that they are positioned centrally in the flueways, see diagram 4.7.

NOTE: The front flueway does not have a baffle.

NOTE: If the heat exchanger has been turned the baffles must still be fitted into the back and middle flue ways only.

Fit the draught diverter onto the heat exchanger with the two securing screws supplied in the fittings pack, see diagram 4.8.

Push fit the sensing tube onto the flue blockage safety device and draught diverter. Secure the sensing tube assembly with the securing screw, see diagram 4.9.

Where a flexible flue liner is being used, fully fit the No8x $\frac{3}{8}$ in self tapping screw provided into the rear of the flue socket as in diagram 4.10.

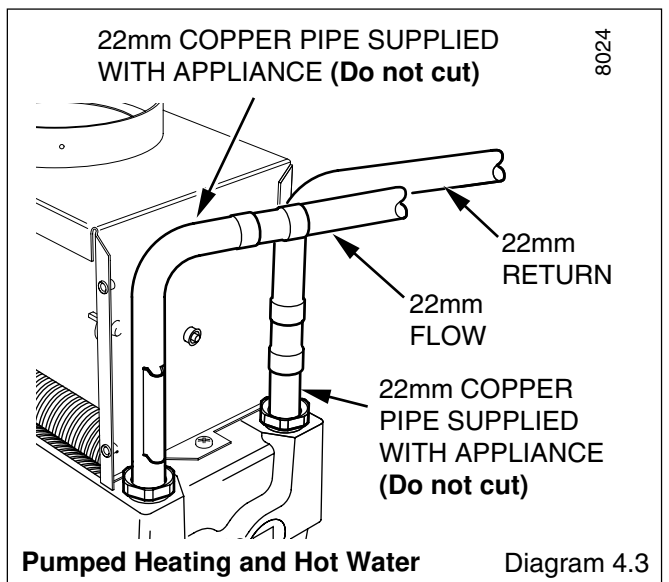
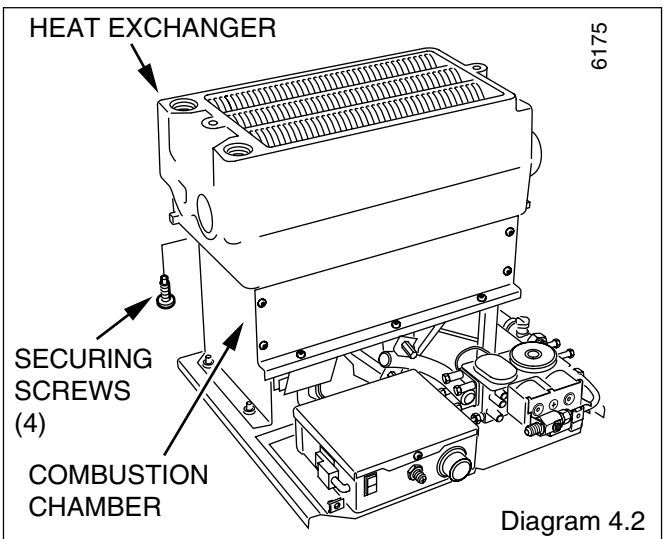
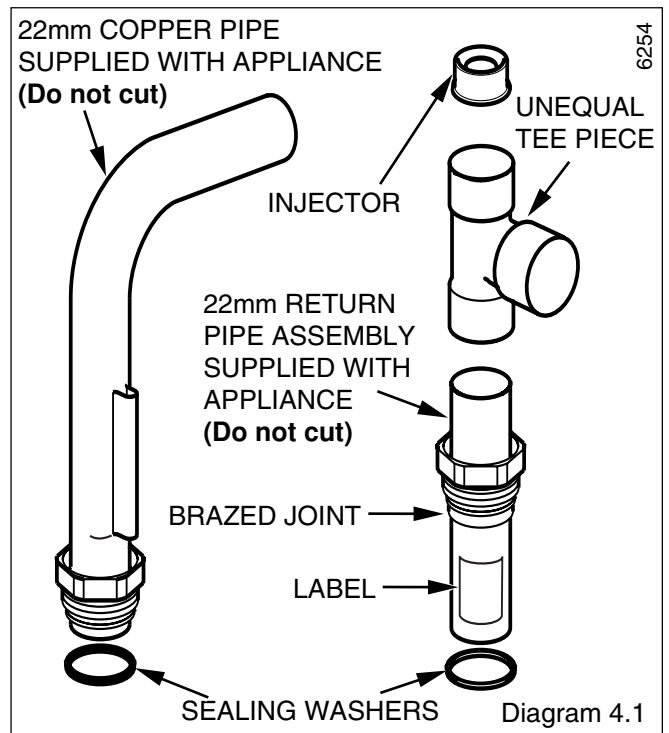

4 Installation

FITTING THE INJECTOR

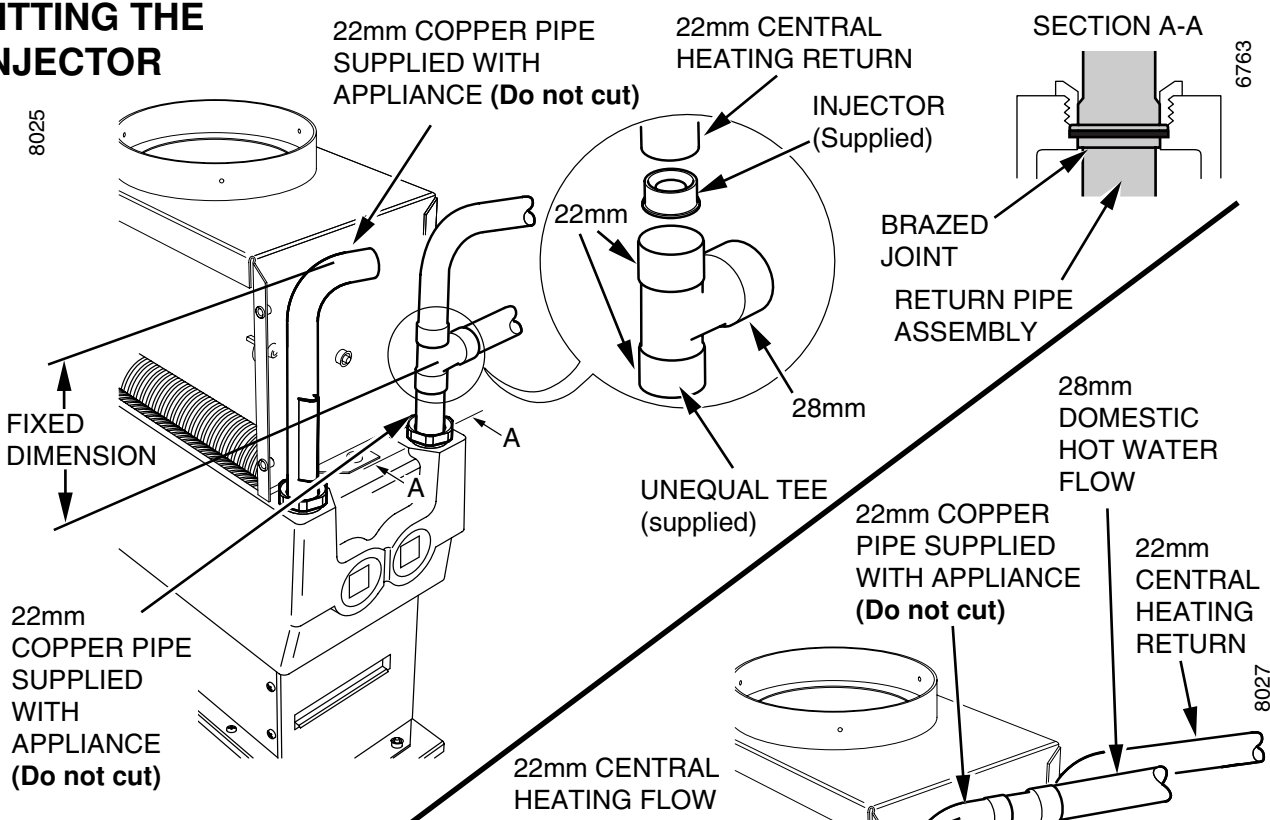

METHOD A

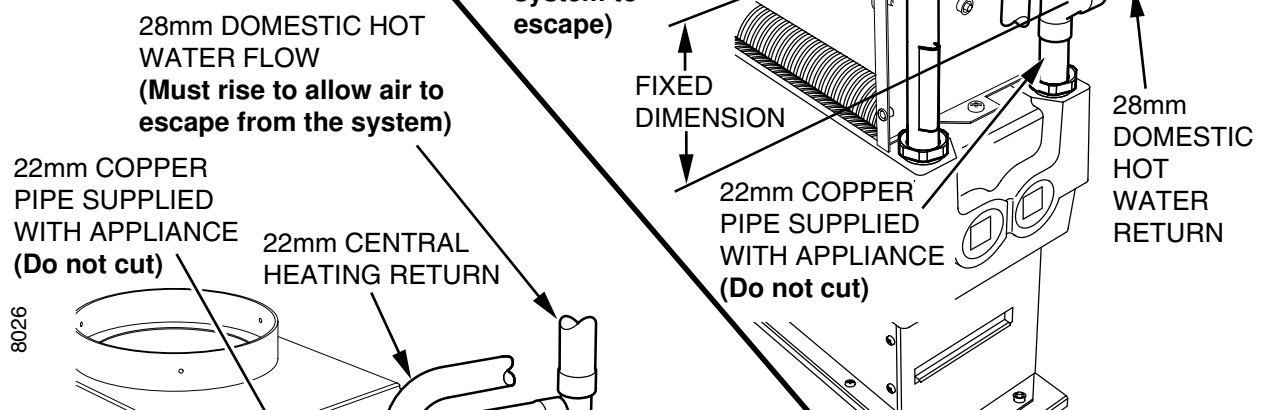

METHOD B

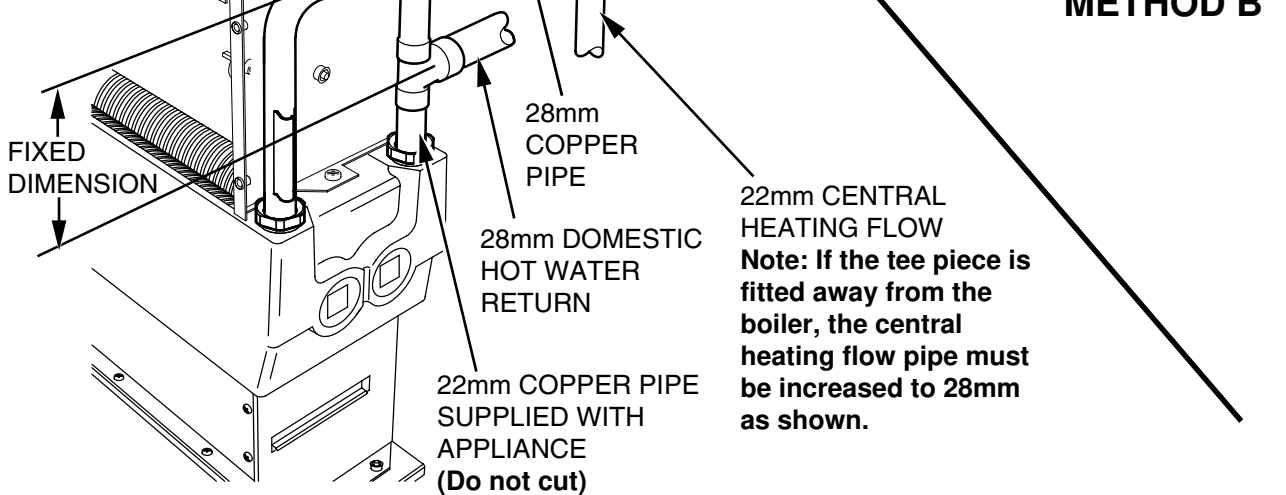

Diagram 4.4

4 Installation

Reposition the back boiler unit into the builder's opening. Connect the system pipework to the back boiler unit/pre-plumbed pipework.

Connect gas supply to gas service cock. Leave gas service cock and gas fire front cock in the "OFF" position, see diagram 4.11 and 6.2.

If a flexible flue liner is being used, position the liner in to the flue socket. Using two No8x $\frac{1}{2}$ in self tapping screws, coloured black, from the fittings pack, screw through the two remaining holes in the flue socket to centralise and secure the flue liner, see diagram 4.10. Seal with a suitable fire clay cement.

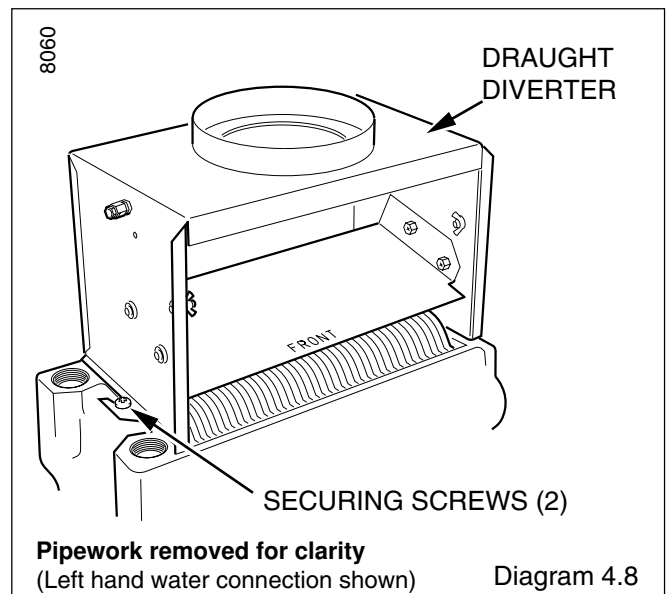
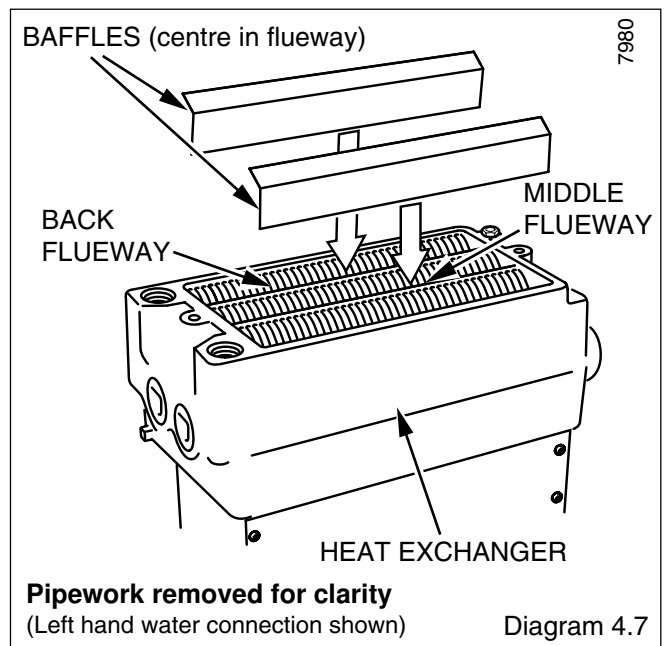
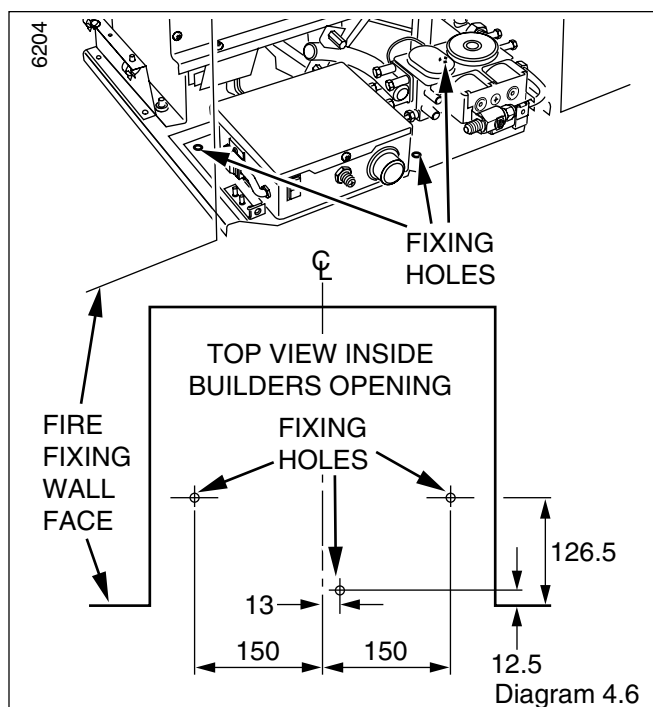
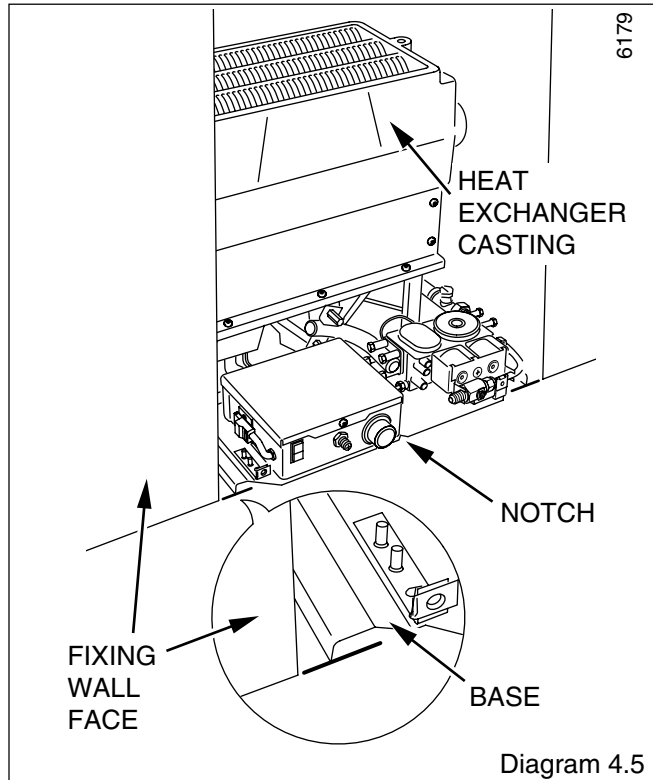

4 Installation

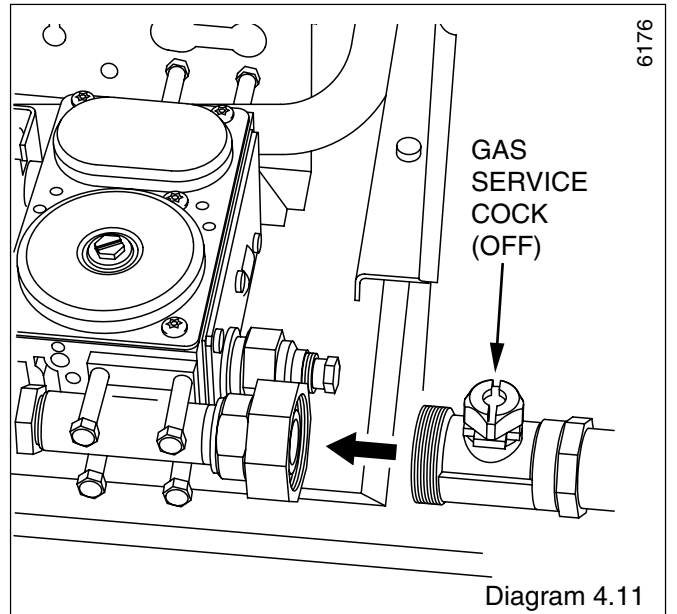
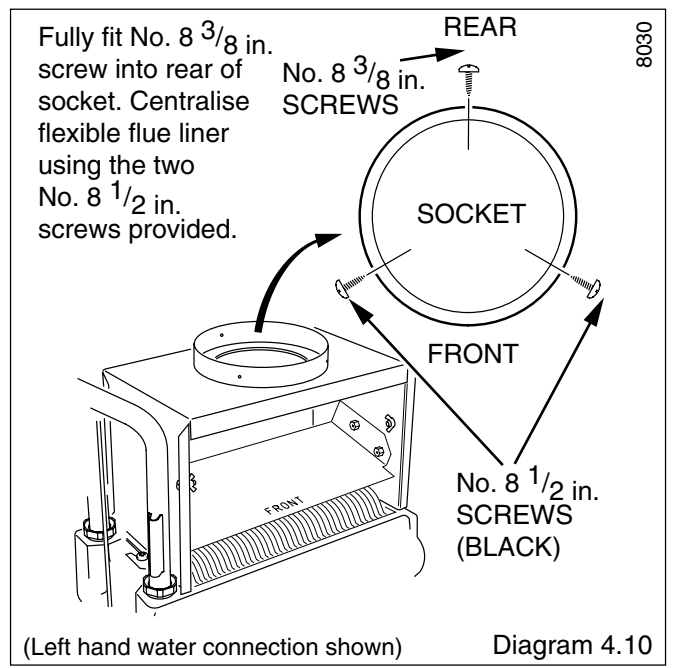
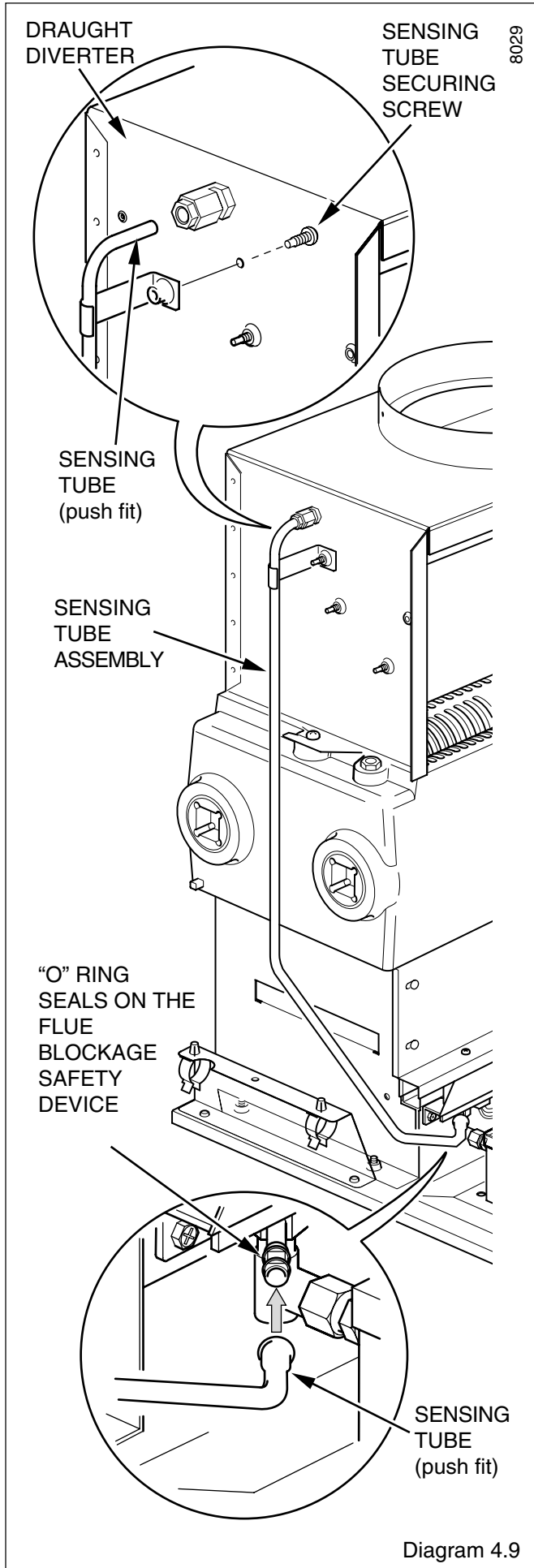

5 Electrical Wiring

5.1 General

WARNING. This boiler must be earthed.

ISOLATE THE ELECTRICAL SUPPLY BEFORE DOING ANY WIRING

All of the electrical installation must be correctly earthed and be in accordance with the current issue of BS7671 and be carried out by a competent person.

The boiler electrical supply is 230V~ 50Hz, fused at 3A. A double pole isolating switch, having a minimum contact separation of 3mm in both poles should be used.

The boiler does not require a permanent live. External controls are connected to the live 'L' terminal in the 3 way plug as an example see diagram 5.1.

Supply cable should be (85°C) PVC insulated type to the current issue of BS6500 Table 16, not less than 0.75mm² (24/0.20mm).

NOTE: The supply to the boiler and any remote control must be through the same isolating switch or plug and socket.

It is preferable to have the boiler electrical supply cable entering the builder's opening at the left.

If the cable has to be routed down the left hand side of the combustion chamber the heat shield assembly supplied in the fittings pack must be used and the cable routed through the clips, see diagram 5.2.

If right hand access is required and the boiler electrical supply cable has to be routed down the right hand side of the combustion chamber keep the cable well clear of hot surfaces. The cable must also be routed in front of the gas control valve, down the side and rear of the electrical control box and restrained using the cable ties supplied in the fittings pack, see diagram 5.3.

NOTE: The boiler electrical supply cable must not be routed along the back of the appliance.

The cable must be kept well clear of hot surfaces.

When fitting the back boiler unit do not trap the cable.

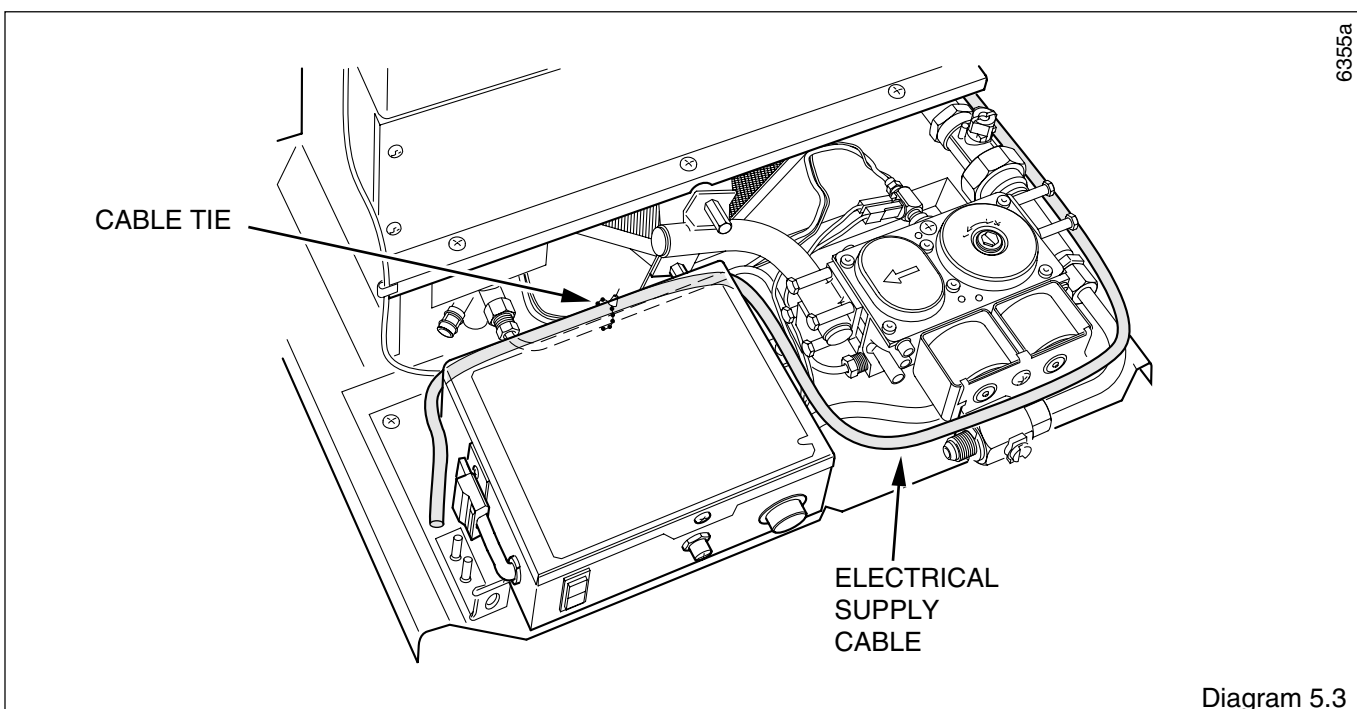
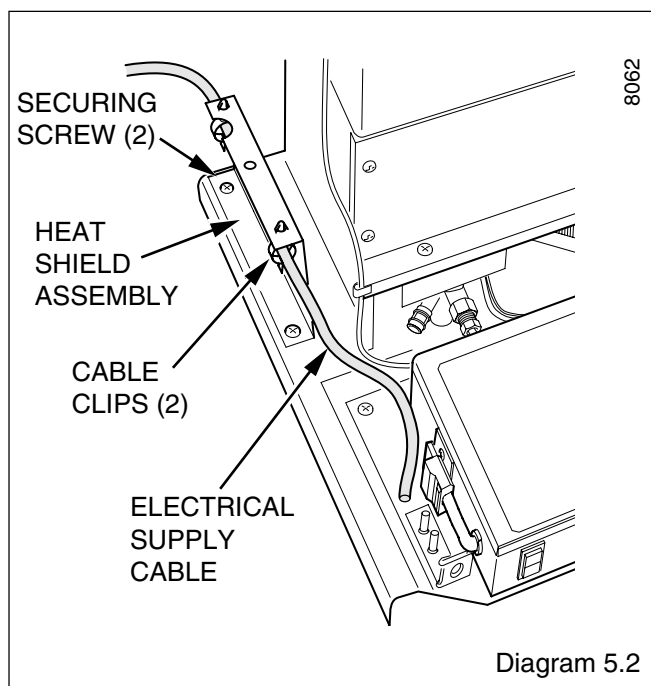
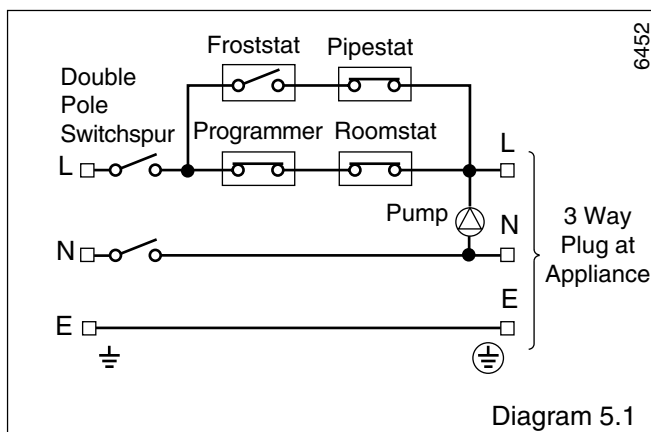

5 Electrical Wiring

5.2 Thermostat Phial

Unwind the capillary avoid kinking. Route the capillary well clear of any part of the back boiler which becomes hot. Use the capillary clips, supplied. Secure the capillary and push the phial into the pocket, see diagram 5.4. Again make sure that the capillary is not touching the casting.

NOTE: When fitting the phial into the phial pocket use the heat sink compound supplied in the fittings pack.

5.3 Boiler Control Box

Taking care that the POWER IS OFF, wire the incoming mains cable to the mains plug supplied in the fittings pack. Do not connect the mains supply plug to the control box socket, see diagram 5.5.

NOTE: The ignition sequence is fully automatic and will commence when mains voltage is applied.

5.4 Testing - Electrical

Checks to ensure electrical safety must be carried out by a competent person.

After installation of the system, preliminary electrical system checks as below should be carried out,

1. Test insulation resistance to earth of mains cable.
2. Test the earth continuity and short circuit of all cables.
3. Test the polarity of the mains.
4. With the mains supply off. Plug the mains supply plug into the control box socket, see diagram 5.5.

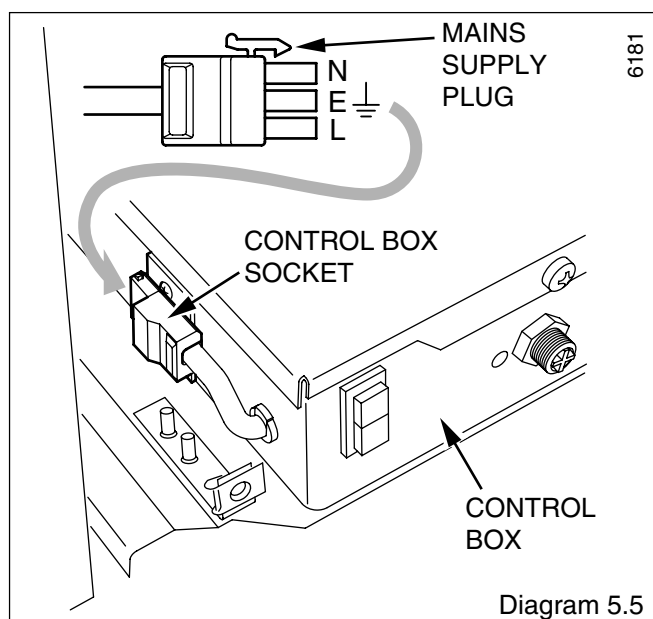
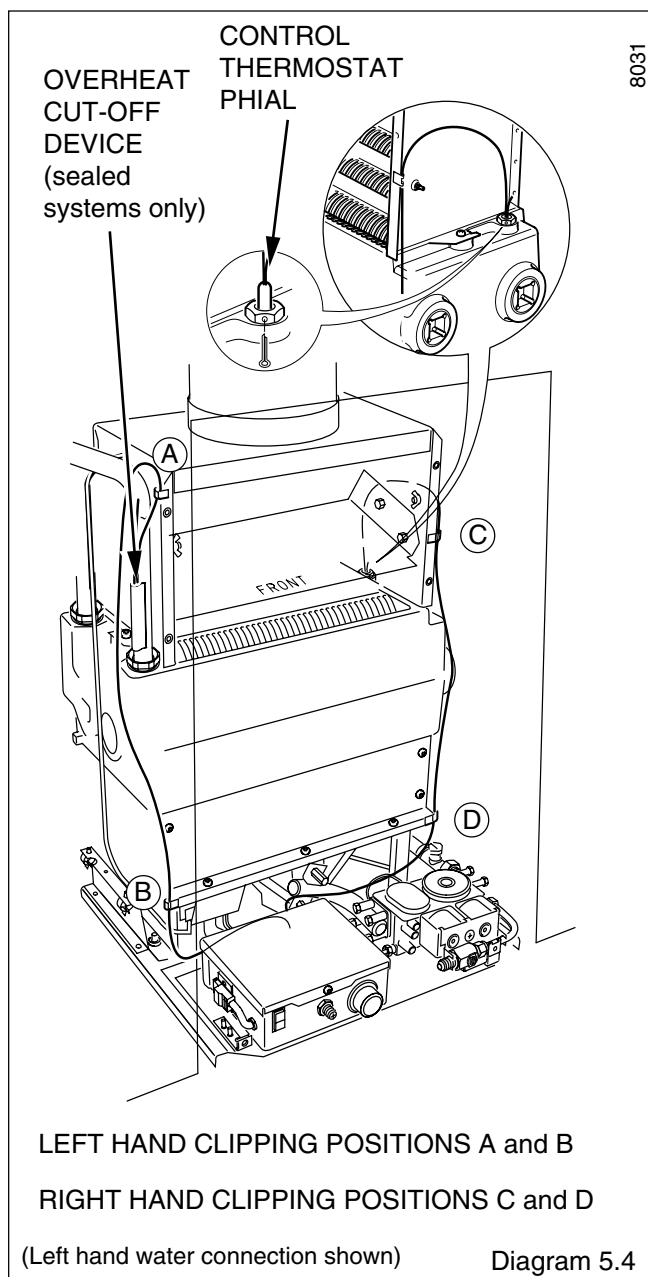

5 Electrical Wiring

6675

KEY

- br - brown
- bk - black
- b - blue
- or - orange
- y - yellow
- g/y - green/yellow
- p - purple
- wh - white
- r - red

SWITCHED
CONTROLLED
SUPPLY
230V~50Hz

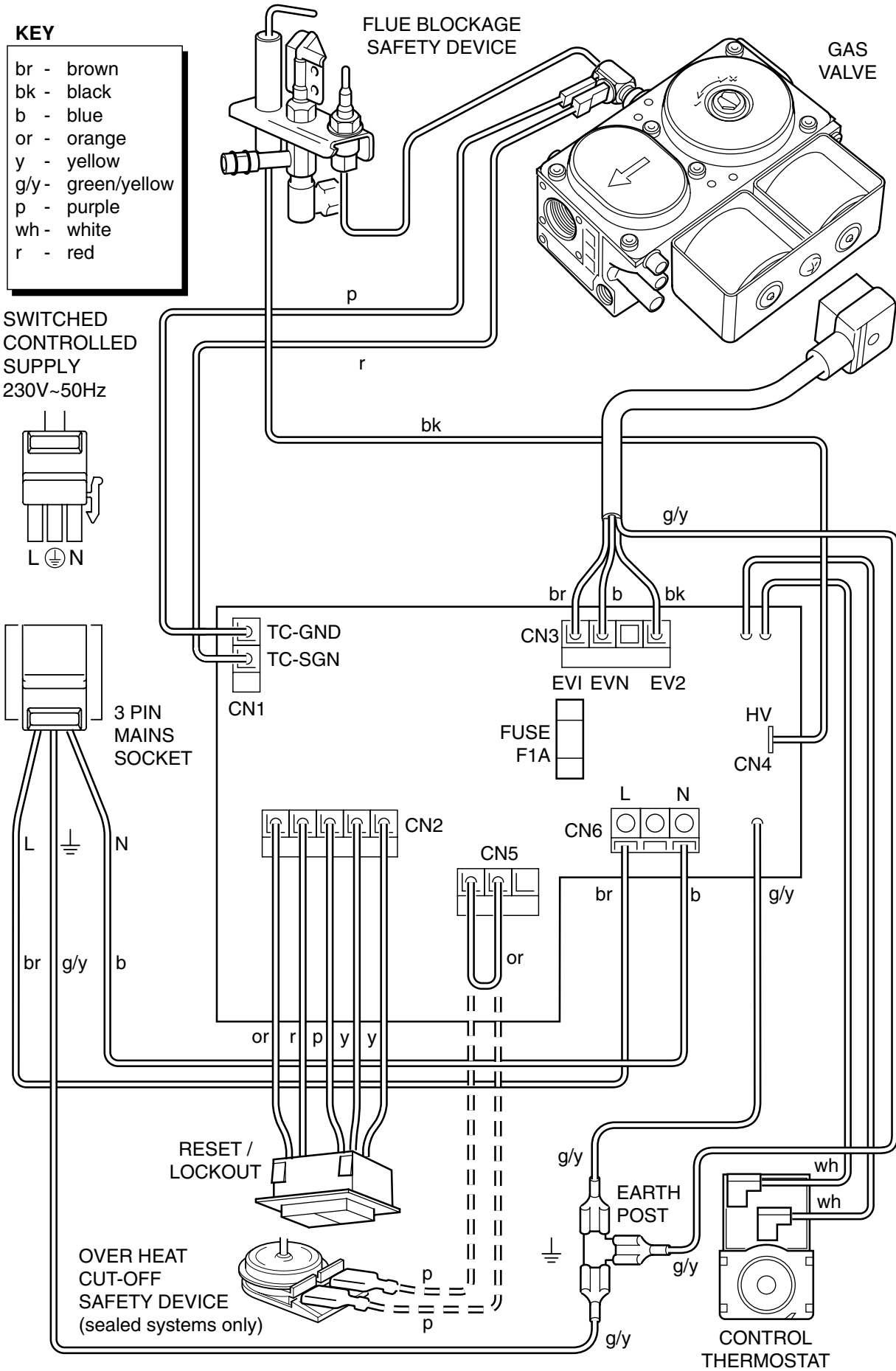
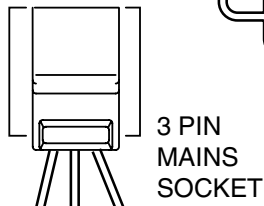
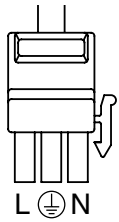

CONTROL BOX AND GAS VALVE WIRING

Diagram 5.6

6 Commissioning

6.1 Commissioning the Back Boiler

Before commissioning the back boiler, the whole of the system should be thoroughly flushed out with cold water with the circulation pump removed. Replace the pump, fill the system and examine for water soundness. Vent air from the system and pump.

The back boiler unit is fitted with a flue blockage safety device, which will shut it down if there is a lack of oxygen. The principle by which this operates is that when there is a depletion of oxygen resulting from a build up of combustion products. The flame on the pilot light will become unstable and lift up off the thermocouple. This will deactivate the mag unit in the gas control valve, cutting off the gas supply.

If the back boiler unit shuts down frequently for no apparent reason the first things to be checked are the chimney and air inlets into the room. Any problems found must be put right, by a competent person, and a full operational test carried out before the back boiler unit is used again.

The flue blockage safety device incorporates the electrode, thermocouple and pilot assemblies.

The flue blockage safety device MUST NOT be adjusted or disconnected. It must be serviced strictly in accordance with the instructions in this book. Any unauthorised interference could result in the device failing to operate, creating a potentially dangerous situation. If replacing, use only the correct and approved parts.

CAUTION: The following work should be carried out by a competent person.

Identify the back boiler controls by reference to diagram 6.1.

Note: Overheat cut-off, see diagram 6.1 is applicable only where the back boiler unit is incorporated in a sealed water system.

Open all windows and put out any naked lights, cigarettes etc.

Test the gas supply for soundness. Purge air in accordance with the current issue of BS6891.

Check that the electrical supply to the back boiler is switched off.

Set the control thermostat knob "A" to "0", "Off" position that is, fully anti-clockwise, see diagram 6.1.

Make sure the thermostat phial is fitted correctly, see diagram 5.4.

Loosen the back boiler burner pressure test screw "B" and connect a suitable pressure gauge.

Turn gas service cock "C" to the "On" position making sure that the fire front service cock "D" is in the "Off" position, see diagram 6.2.

Technical Sequence of Operation

When an external control calls for heat there is approximately a 30 second purge. The control board (PCB) energises the thermoelectric valve and spark unit. With the thermoelectric valve open gas is allowed to pass to the flue blockage safety device which will be ignited by the sparks. This ignition attempt will continue until the milli-voltage generated by the thermocouple is sufficient to hold open the pilot valve. At this point the thermoelectric valve and spark unit are de-energised and the green light on the lockout reset button "E" will illuminate, see diagram 6.1. The main gas control valve is energised through the closed contacts of the control thermostats. When the water temperature has reached the set point the control thermostat contacts open, the main gas control valve is closed. The pilot will, however, remain alight since the thermocouple is generating the required milli-voltage.

When the the water temperature falls below the set point the control thermostat control will close, thus energising the main gas control valve and allow the main burner to light from the pilot light.

The boiler will continue to cycle in this manner until the external control stops its demand for heat. At this point external power is removed the main gas control valve and the thermocouple milli-voltage is reduced to zero.

That is to say whilst ever there is a demand for heat from an external control the pilot will remain alight despite the boiler thermostat cycling on or off.

Check the pilot flame is stable and has a length as shown in diagram 6.3.

Note: Should the red light on the lockout reset button "E" come on, it indicates that the pilot light is not operating correctly, or the flue blockage safety device has been activated.

Depress the lockout reset button "E", when the fault has been corrected indicated by the green light illuminating, see diagram 6.1.

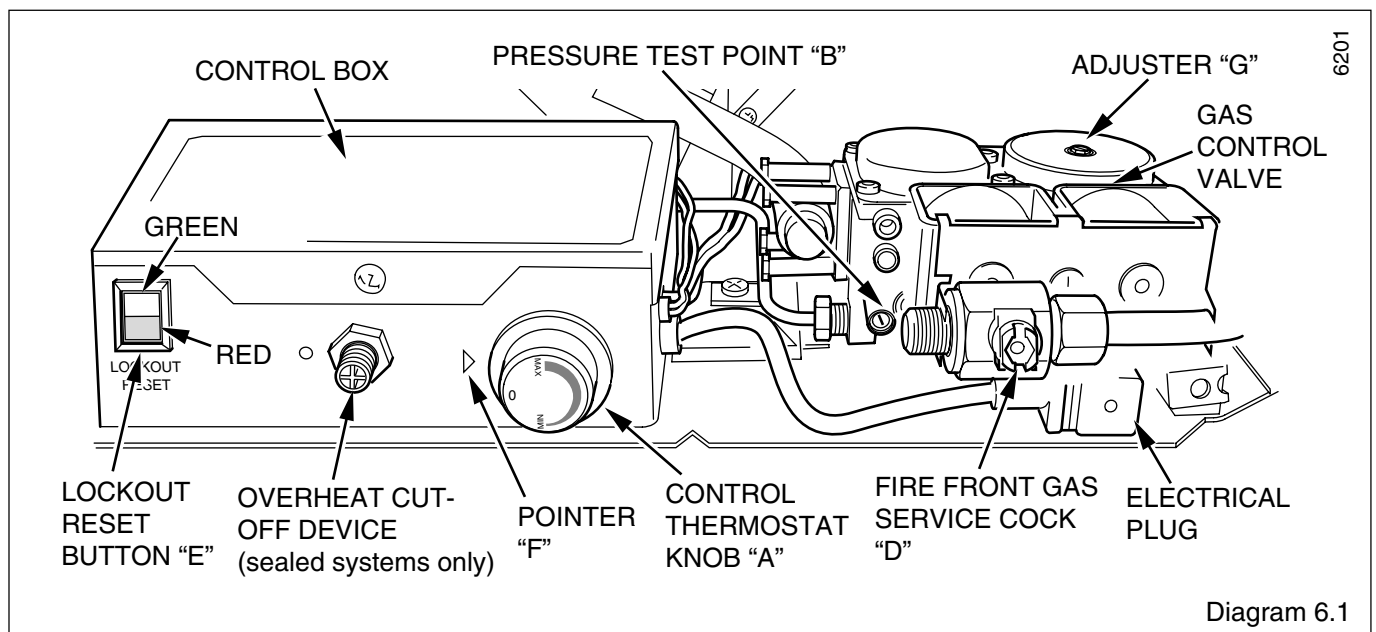

6 Commissioning

Turn control thermostat knob "A" clockwise until "MAX" is against the pointer positioned on the control box front cover "F". The main burner will light.

Test for gas soundness using a suitable leak detection fluid.

The back boiler is supplied preset to the maximum heat input but may be adjusted to suit design requirements. Refer to Data Label or Table 1 for details, Section 1.2.

If adjustment is required, TEN MINUTES after lighting, turn adjustment screw "G", anti-clockwise to suit system design heat input, see diagram 6.1 and 6.2.

Should any doubt exist, the gas rate should be checked at the gas meter.

The rate of the back boiler should be within the range:

For the BBU 50: 1.40m³/h to 1.70m³/h,
(49.5ft³/h to 60.0ft³/h)

Note, if the gas rate is checked, make sure that all other gas appliances and pilot lights are turned off.

Turn control thermostat knob "A" anti-clockwise to "0", "Off" position. Remove pressure gauge and replace test point screw ensure a gas tight seal is made.

Relight the back boiler by turning thermostat knob "A" clockwise to "MAX".

Use the self adhesive arrow from the fittings pack and stick it against the relevant heat input figure on the Data Label.

Refer to sequence of operation below.

LIGHTING SEQUENCE OF OPERATION

6679

1. Switch on the electrical supply to the boiler and heating systems.
2. Set external controls if fitted, to demand heat.
3. Turn the boiler control thermostat knob fully clockwise to the maximum setting.

The lighting sequence is automatic as follows:-

4. Approximate 30 second purge.
5. Ignition initiated sparking at electrode EV1 energised, (Pilot solenoid) pilot lights.
6. EV2 energised, (Main burner solenoid) main burner lights.

6.2 Testing the Back Boiler Controls

To test the lockout device, turn the boiler on. After about 3 minutes, turn the gas off at the gas service cock, the lockout device should now operate. This is indicated by the red light coming on at the reset button.

To restart the boiler, turn on the gas supply at the gas service cock and press the lockout reset button "E".

DO NOT ATTEMPT TO RELIGHT UNTIL AT LEAST 3 MINUTES HAVE GONE BY.

Check that the boiler thermostat control and any external controls operate the back boiler correctly.

6.3 Clearance of Products

A clearance of products (spillage) test must be carried out after installation of the back boiler and it's fire.

Before fitting the fire, check that the heat exchanger baffles are fitted and seated correctly, see Section 4.9.

Details of the necessary tests to be carried out will be found under "TEST FOR CLEARANCE OF PRODUCTS" in the Fire Front Installation Instruction Booklet.

Note: This test must only be carried out after the fire front has been fitted to the back boiler unit.

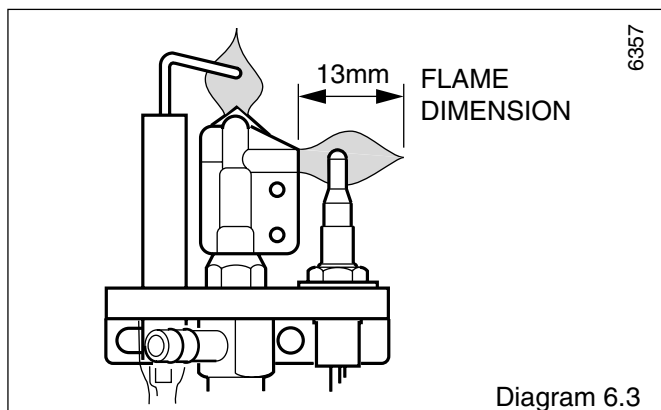
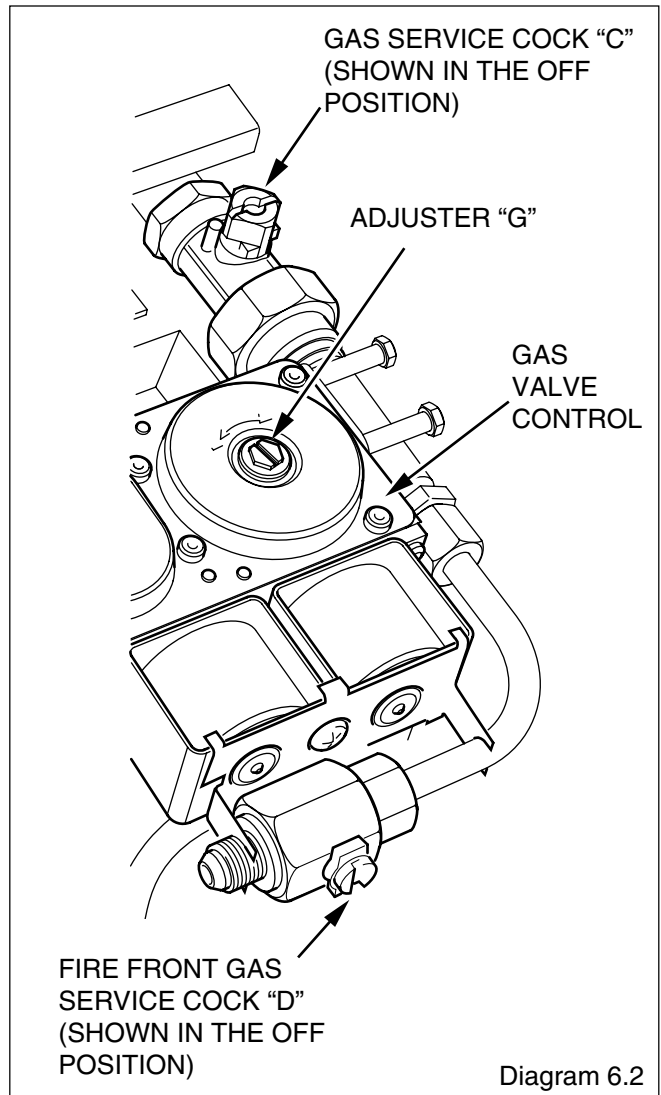

6 Commissioning

6.4 Commissioning the System

Set all controls to operate the heating system. Adjust circulating pump and balance the system to give a temperature drop across the boiler of 11°C (20°F). At the appropriate flow rate, the resistance of the back boiler can be found by reference to diagram 6.4.

There should be no undue noise in the pipework or heat emitters. There must be NO pumping over of water or entry of air at the open vent pipe above the feed and expansion cistern.

Make sure the back boiler control thermostat knob "A" is turned clockwise to "MAX", which is about 82°C (180°F), against the setting point, allow the water to reach maximum working temperature. Examine the system for water soundness.

Turn the control thermostat knob "A" anti-clockwise to "Off" and rapidly drain the system whilst still hot, to complete the flushing process.

Refill the system, vent and check again for water soundness.

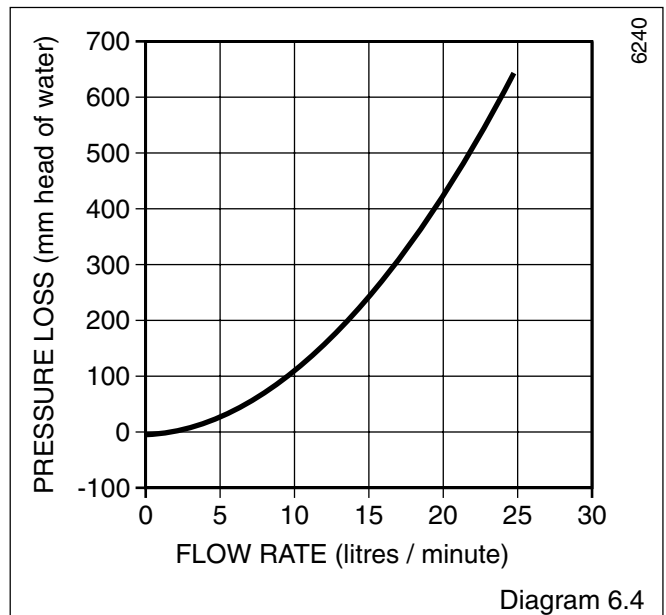

7 Fire Installation

Fire Front Installation and Servicing Instructions are packed with the fire.

7.1 Completion - After Installation of the Fire Front

Instruct and demonstrate to the user, the efficient and safe operation of the boiler, heating and hot water system and fire front.

Hand the Instructions for Use to the user, making sure that they are understood.

Advise the user that to ensure the continued efficient and safe operation of the appliance it is recommended that it is checked and serviced as necessary at regular intervals. The frequency of the servicing will depend upon the particular installation conditions and usage, but in general once a year should be enough.

Draw attention, if applicable, to the current issue of the Gas

Safety (Installation and Use) Regulations, Section 35, which imposes a duty of care on all persons who let out any property containing a gas appliance.

It is the law that any servicing must be carried out by a competent person.

Set any remote controls for the system to settings requested by the user.

Advise that the boiler is fitted with a flue blockage safety device and refer to the Instructions for Use.

Advise the user of the importance to keep any purpose built ventilation system where the appliance is installed, clear of any obstruction that would impede its efficiency.

Reminder, leave these instructions with the user.

Advise the user that the 'Benchmark' logbook should be completed by the installation engineer on completion of commissioning or servicing.

8 Servicing

Servicing Notes

- To ensure the continued efficient and safe operation of the appliance it is recommended that it is checked and serviced as necessary at regular intervals. The frequency of the servicing will depend upon the particular installation conditions and usage, but in general once a year should be enough.
- It is the Law that servicing must be carried out by a competent person.
- Remove the fire front
- Refer to the Gas Fire Front Installation and Servicing Instructions for full details of fire front removal.
- After completing any servicing always test for gas soundness with a suitable leak detection fluid and carry out functional check on controls.
- Unless stated otherwise reassembly of all components is in the reverse order to that for removal.

8.1 Isolation of Services

With the fire front removed.

Refer to diagram 6.1 to identify the controls.

Turn control thermostat knob "A" anti-clockwise to "0" "Off" position.

Isolate the electrical supply to the back boiler.

Turn appliance gas service cock to "Off", see diagram 6.2.

8.2 Sensing Tube Assembly.

Remove the sensing tube securing screw, carefully pull the sensing tube assembly away from the sensing tube fitting on the draught diverter and from the flue blockage safety device.

Remove the sensing tube fitting and the tubing nut to access the filter.

Clean or replace the filter, check the "O" rings for damage, replace if necessary, see diagram 8.1.

IMPORTANT NOTE: When replacing the sensing tube check the "O" rings and filter are fitted.

8 Servicing

8.3 Controls Assembly and Burner.

Disconnect the union at the gas service cock, see diagram 8.2.

Remove the thermostat phial and overheating cut-off device phial if fitted (sealed systems only), from the phial pockets, unclip the capillary tubes, see diagram 5.4.

Disconnect the mains electrical plug from the control box, see diagram 8.2.

Remove the four combustion chamber securing screws.

Remove the gas manifold securing screw and slide the control/burner assembly forwards to remove, see diagram 8.2.

8.4 Burner

Disconnect the pilot tube nut and the thermocouple nut from the gas control valve, see diagram 8.3.

Disconnect the ignition lead at the electrode.

Remove the extended screws which locate the gas manifold to burner, see diagram 8.3.

The control box and gas control valve can now be lifted clear of the burner.

Clean the burner as necessary, do not use a brush with metallic bristles.

8.5 Lint Arrester

Remove the four securing screws to disengage the two lint arresters, see diagram 8.4.

Clean the lint arresters as required.

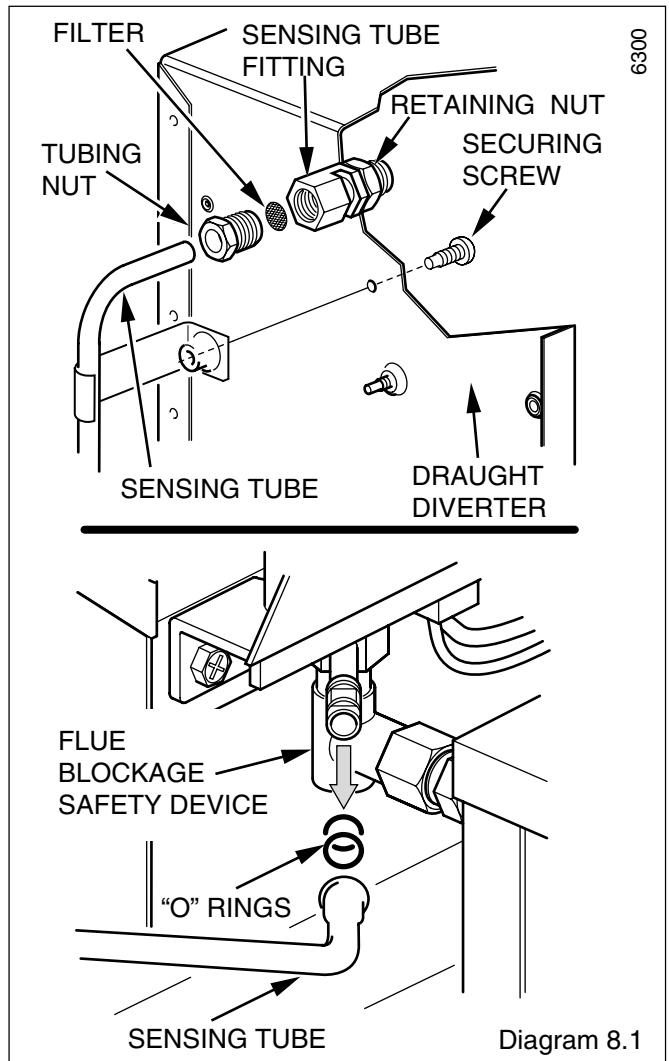

6300

Diagram 8.1

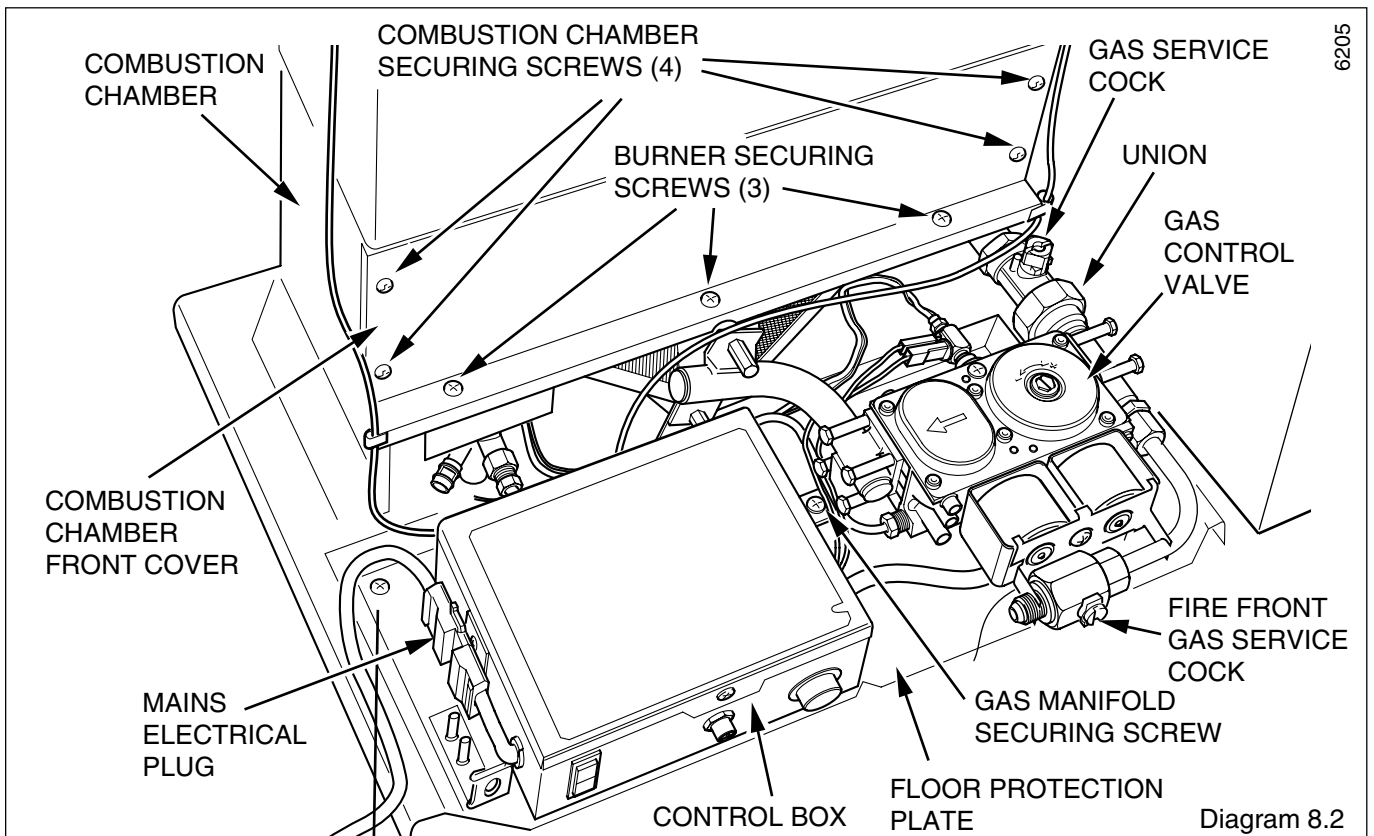

6205

Diagram 8.2

8 Servicing

8.6 Main Burner - Injector

Inspect the main burner injector for damage or blockage, clean or replace as necessary. If replacing ensure the new copper washer is fitted, see diagram 8.5.

Do not use a wire or sharp instrument to clean the injector hole.

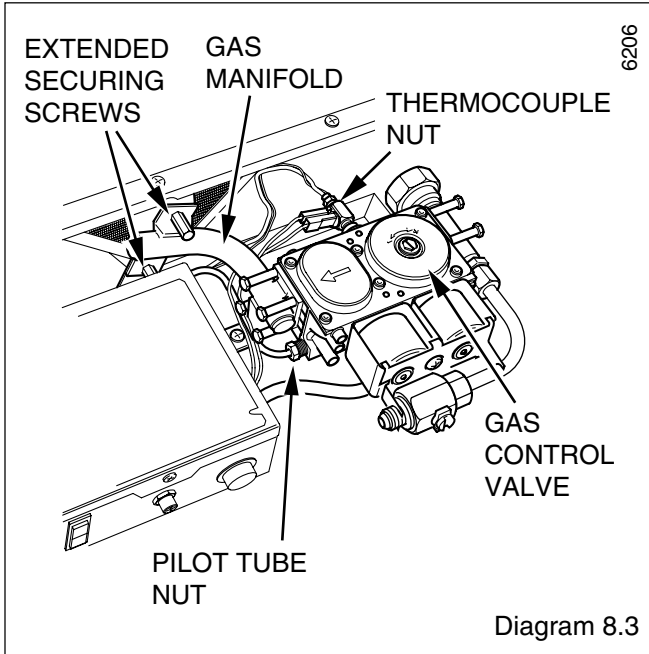

Diagram 8.3

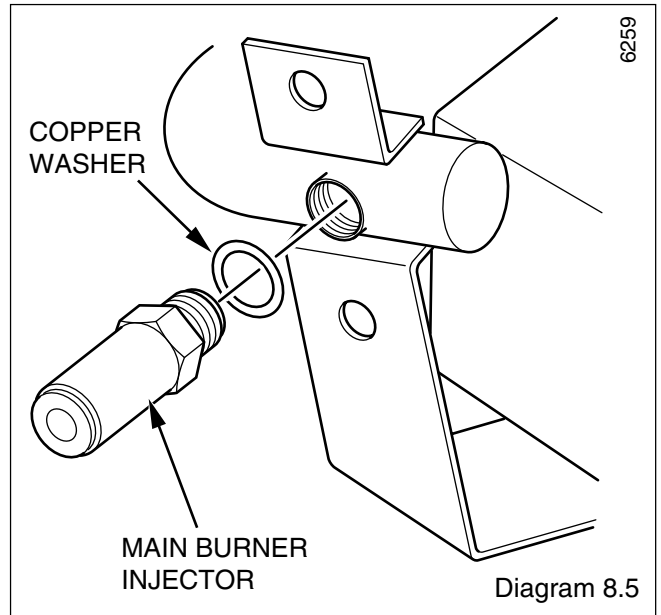

Diagram 8.5

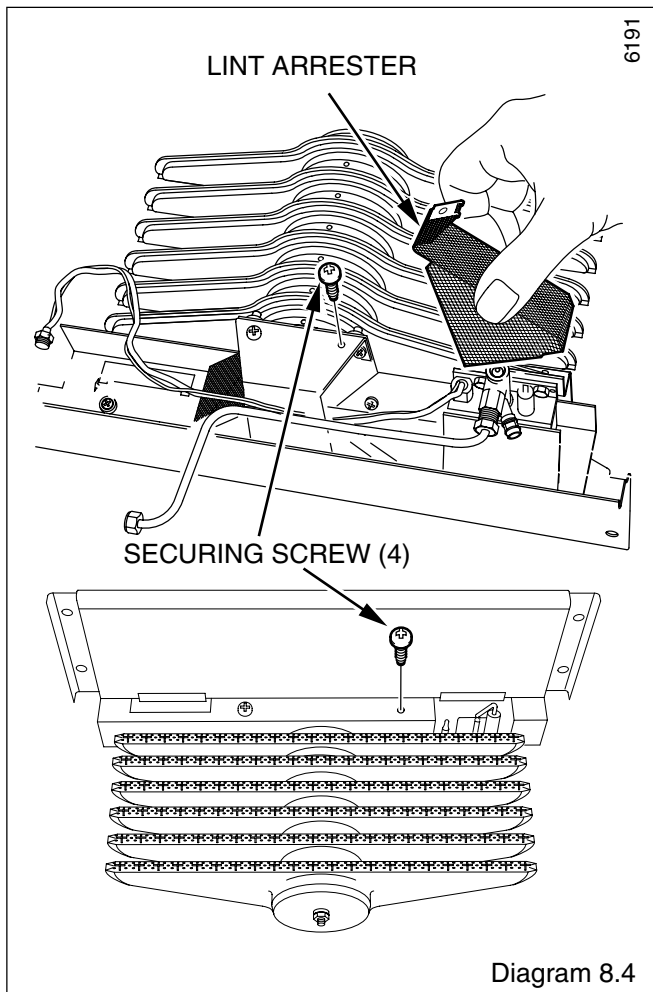

Diagram 8.4

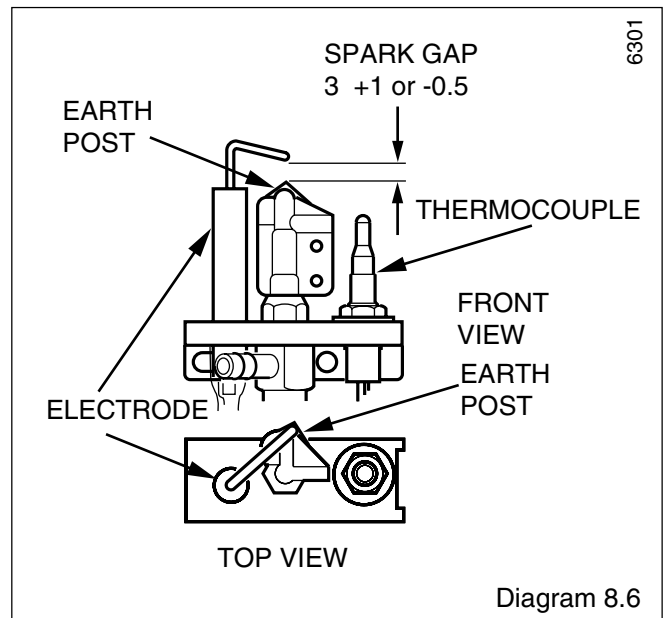

Diagram 8.6

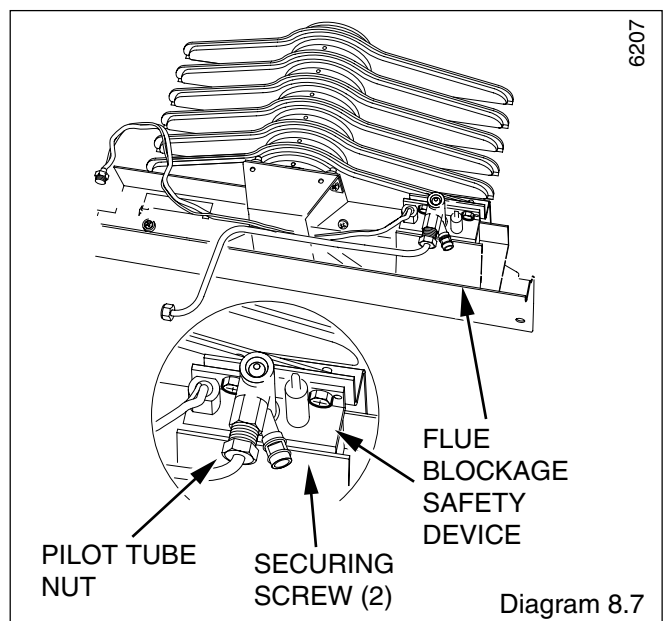

Diagram 8.7

8 Servicing

8.7 Flue Blockage Safety Device Assembly

Gain access as relevant part of Section 8.3. Remove any dust and lint, inspect the pilot for damage. Remove the sensing tube adapter, to clean, blow through, do not use a wire or sharp instrument. If necessary replace the flue blockage safety device.

Check for the correct spark gap, see diagram 8.6.

To remove the safety device, remove the two securing screws, see diagram 8.7.

8.8 Ignition Lead

Inspect the ignition lead for wear or damage, clean or replace as necessary.

8.9 Electrode

Ensure the electrode is in line with the earth post and the spark gap is as shown in diagram 8.6.

Inspect the electrode for wear or damage, clean, or replace the flue blockage safety device, see diagram 8.7.

To remove the safety device, disconnect the pilot tube nut and two securing screws, see diagram 8.7.

8.10 Thermocouple

Inspect the thermocouple for wear or damage, clean or replace as necessary the flue blockage safety device, see diagram 8.7.

To remove the safety device see diagram 8.7.

Note: When reassembling the burner assembly the following points should be observed:

- Make sure that the lint arresters are engaged in the correct position on the burner support bracket.
- DO NOT replace the combustion chamber control/burner assembly into the back boiler until the boiler flueways servicing has been carried out.

8.11 Back Boiler Flueways

Undo the four screws securing the lower draught diverter plate, see diagram 8.8 and remove.

Lift out the flue baffles, see diagram 8.9.

Place a sheet of paper in the base of the combustion chamber.

Clean the boiler flueways with a suitable stiff brush.

To make sure that the flueways are clean, view with the aid of a mirror or reflector.

Remove the paper and debris.

When refitting make sure that the baffles are correctly orientated and seated and are centred in the flueways see diagram 8.9.

NOTE: There is no baffle in the front flue way.

NOTE: If the heat exchanger has been turned the baffles must still be fitted into the back and middle flue ways.

Refit the lower draught diverter plate using the four screws previously removed.

NOTE: The draught diverter is stamped FRONT to aid fitting, see diagram 8.8 for correct position.

Now refit the control/burner assembly.

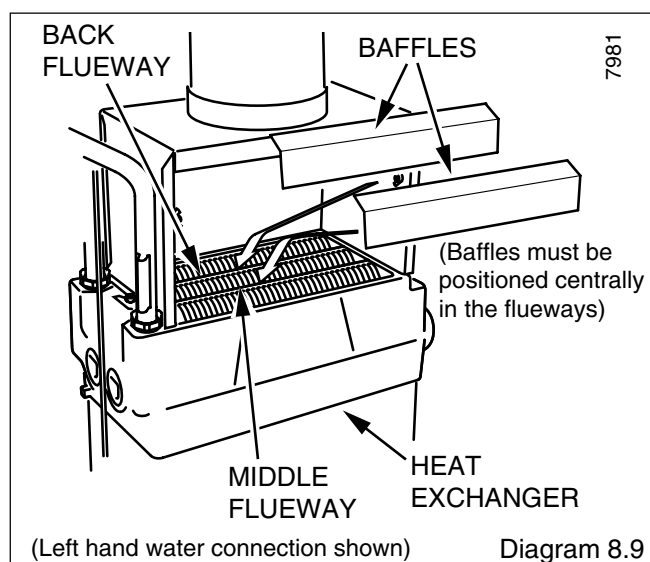
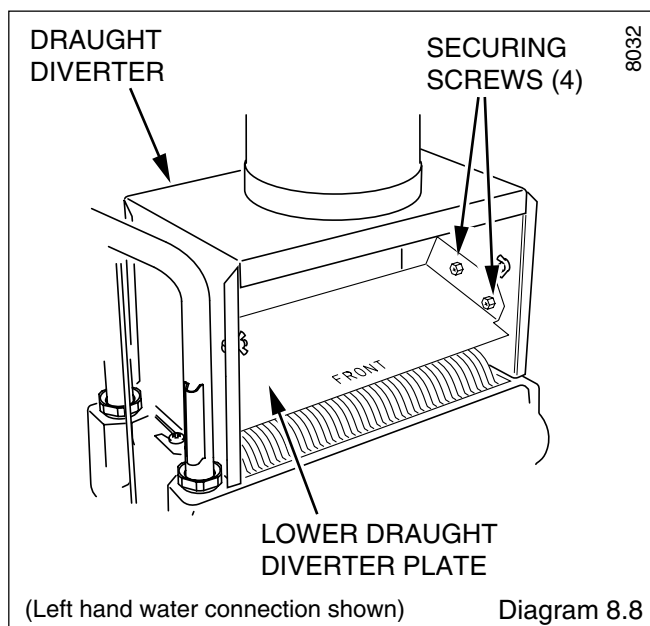

9 Fault Finding

9.1 Electrical

Carry out the preliminary electrical system checks as contained in a multimeter instruction book.

Refer to electrical fault finding chart, diagram 9.1 and functional flow wiring diagram 9.2.

On completion of the fault finding task which has required the breaking and remaking of electrical connections, the checks for earth continuity, short circuit, polarity and resistance to earth must be repeated.

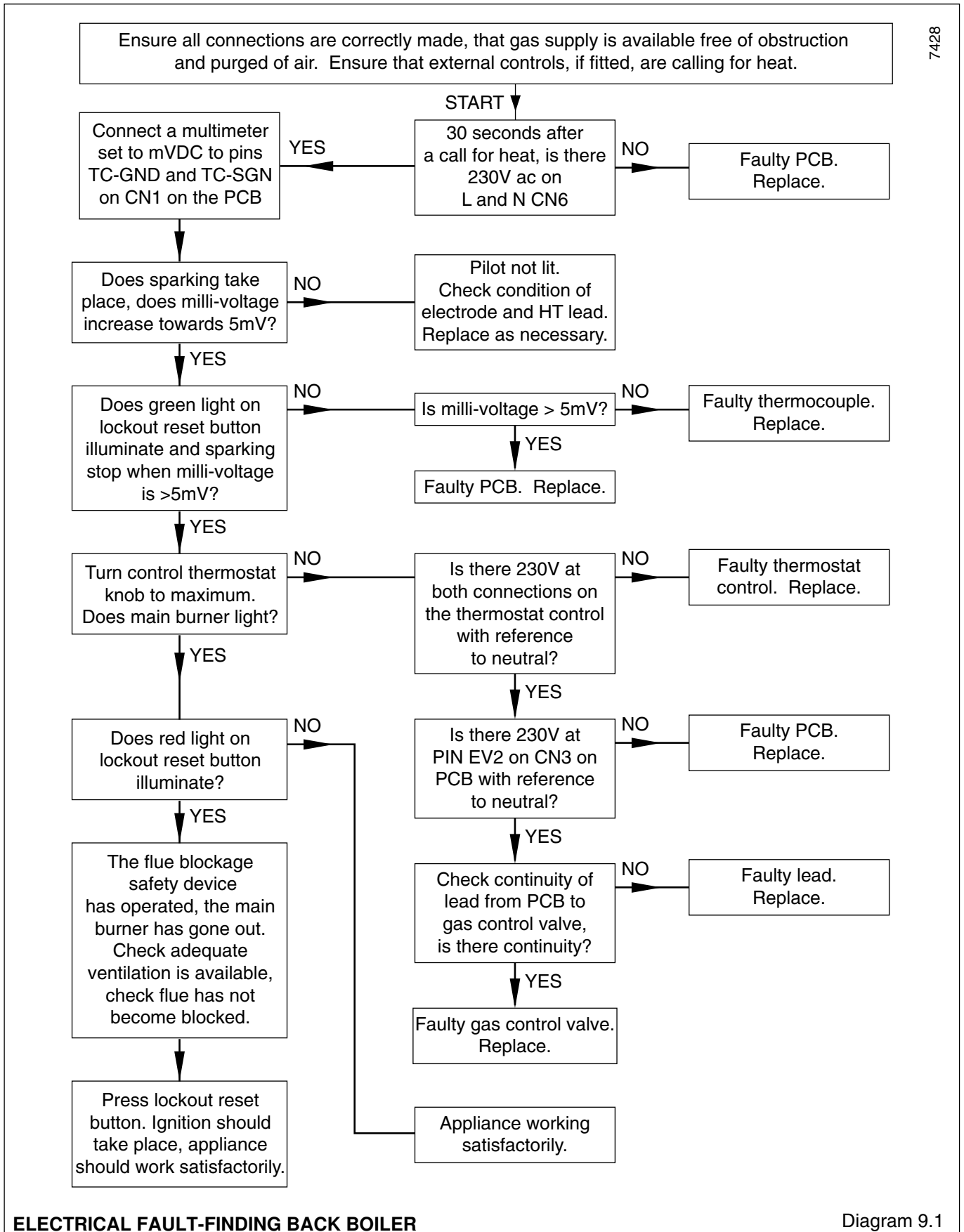

ELECTRICAL FAULT-FINDING BACK BOILER

Diagram 9.1

9 Fault Finding

9.2 Thermocouple

To test the thermocouple, a meter with a range of 0 - 30mV is required together with a thermocouple interrupter test unit.

9.4 Flue Blockage Safety Device and Ignition Fault Finding

To check the safety device and ignition, refer to fault finding chart, diagram 9.1.

9.3 Electrical Fault Finding Back Boiler

Refer to diagram 9.1.

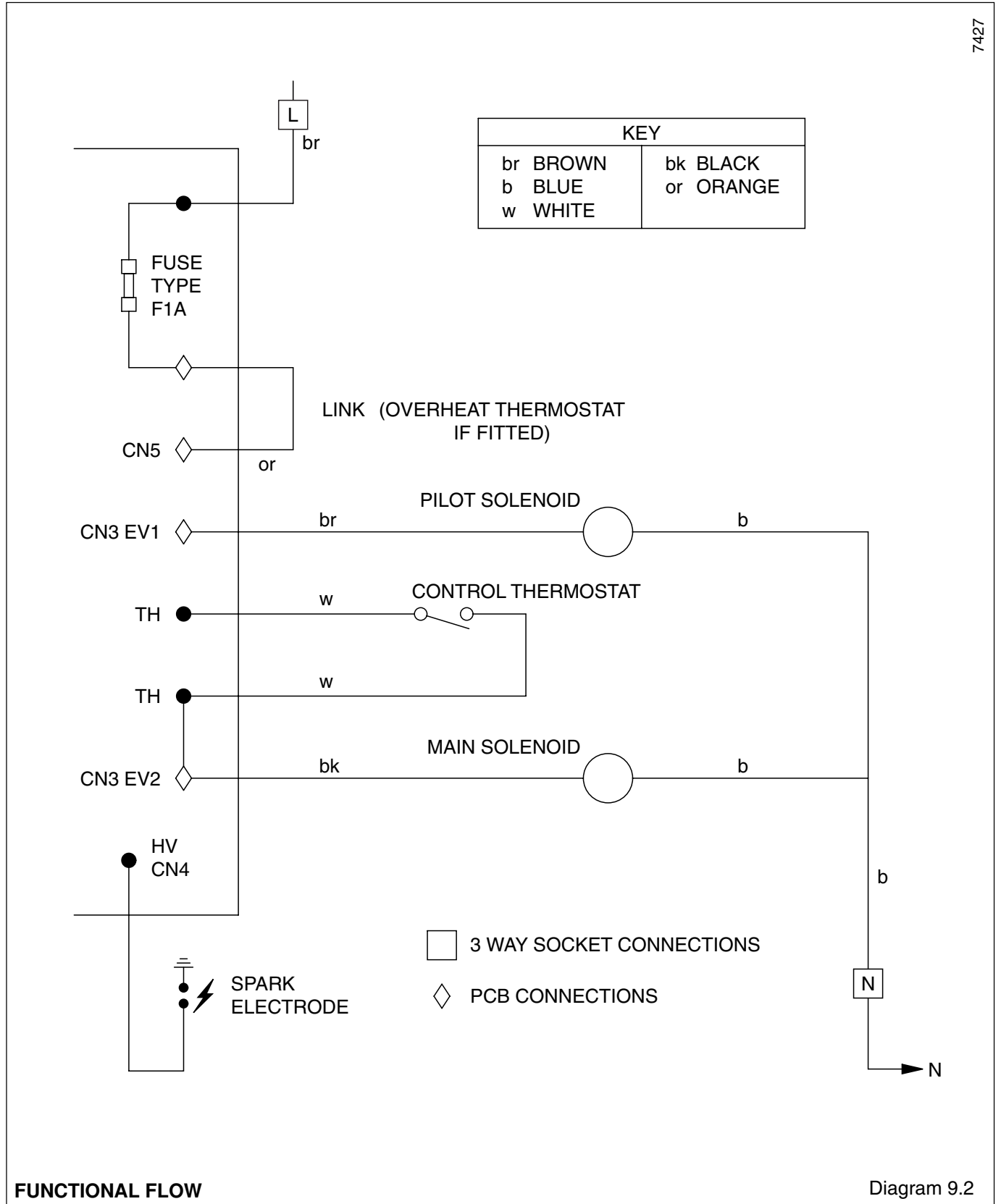

10 Replacement of Parts

Notes.

- Replacement of parts must be carried out by a competent person.
- Unless stated otherwise all parts are replaced in the reverse order to that of removal.
- After replacing any gas carrying parts always test for gas soundness using a suitable leak detection fluid. Also carry out functional check of controls.
- Refer to the Gas Fire Installation Instructions for details of the removal of the fire front.
- Isolate the electrical supply to the back boiler.
- Refer to diagram 6.1 to identify the back boiler controls.

Turn the thermostat control knob clockwise to "0", "Off" position. Turn the appliance gas service cock anticlockwise to "0", "Off" position, see diagram 6.2.

10.1 Sensing Tube Assembly.

Refer to Section 8.2.

10.2 Flue Blockage Safety Device

Follow the instructions in Section 8.2 and 8.3 to remove the sensing tube assembly and controls assembly and burner.

Refer to diagram 10.1.

Remove the ignition lead from the electrode.

Disconnect the thermocouple nut.

Disconnect the pilot pipe nut.

Remove the safety device securing screws.

Remove the safety device.

10.2 Thermocouple

Proceed as in Section 10.2.

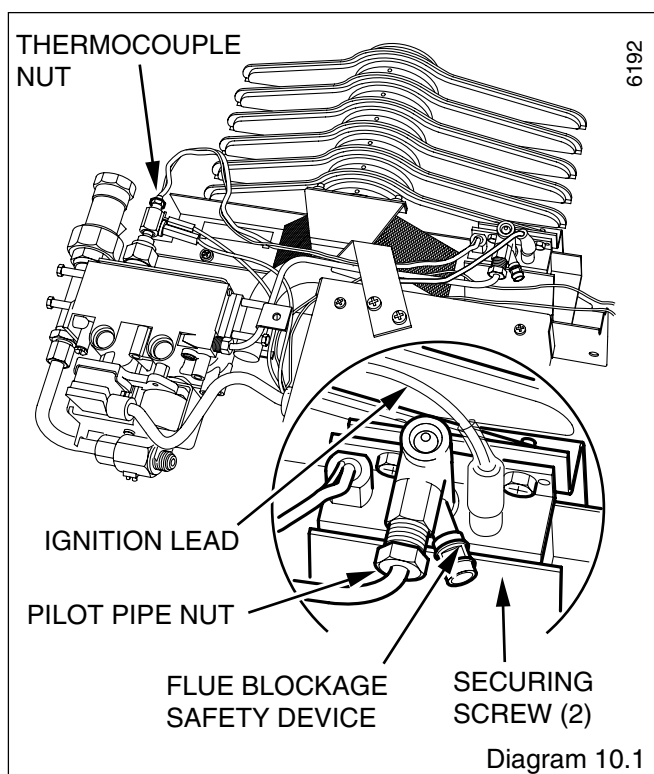

10.3 Electrode

Proceed as in Section 10.2.

10.4 Ignition Lead

Remove the control box lid.

Remove the lead from the electrode.

Remove the lead from the control board (PCB).

When replacing make sure the lead passes through the grommet in the rear of the control box and the protective silicone sleeve is replaced.

10.5 Injector - Main Burner

Follow the instructions in Section 8.4 to remove the burner.

Replace the main injector, Ensure you fit the new copper washer, see diagram 8.5.

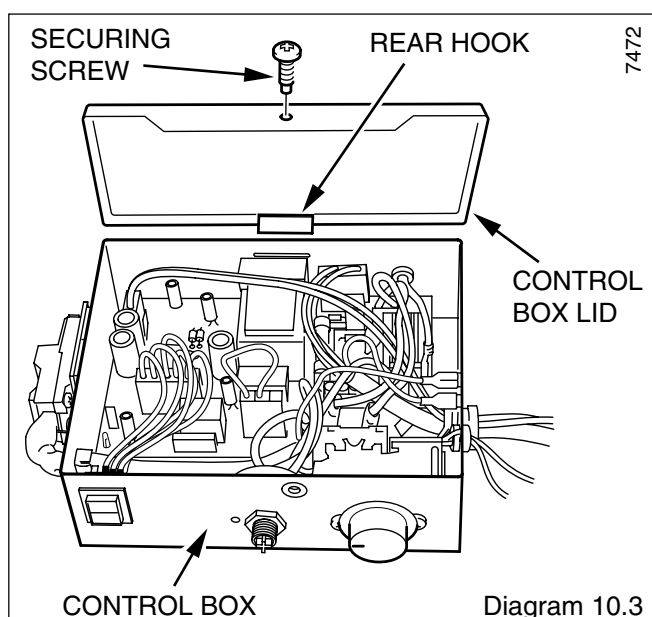
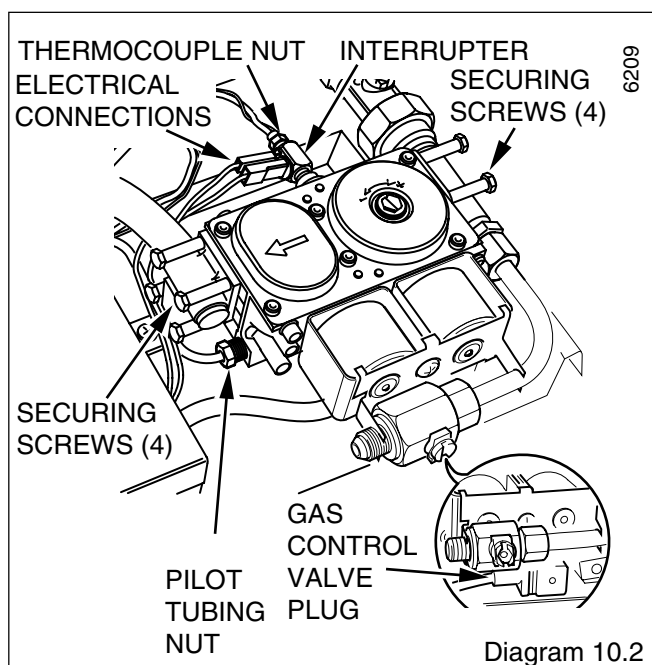

10 Replacement of Parts

10.6 Gas Valve

Refer to the relevant parts of Section 8.3 to remove the controls assembly.

Refer to diagram 10.2.

Disconnect electrical plug.

Disconnect the thermocouple nut at the gas valve and ease out.

Disconnect interrupter electrical connections.

Disconnect the pilot tubing nut at the gas valve.

Undo the securing screws to separate the valve from the supply pipe flange and gas manifold.

Note. When replacing the thermocouple only tighten the nut a quarter turn beyond finger tight.

Fit the new "O" ring seals supplied with the new gas control valve.

Should the solenoids require replacing, refer to Section 10.12.

10.7 Burner

Follow the relevant instructions in Section 8.3 and 8.4 to remove the burner.

Transfer the flue blockage safety device to the new burner, see diagram 10.1.

10.8 Control Thermostat

Remove the control thermostat phial and unclip the capillary tube, see diagram 5.4.

Remove the electrical control box lid securing screw and lift the lid back to release the rear hook, see diagram 10.3.

Remove the control knob, see diagram 10.4.

Remove the two electrical connections from the thermostat, see diagram 10.4.

Remove the two securing screws and remove the control thermostat and capillary from the split grommet, see diagram 10.4.

Note: When fitting the new control thermostat, make sure that the capillary connection to the thermostat is placed at the bottom of the control box.

Refit the electrical connections.

The capillary should pass through the split grommet on the control box.

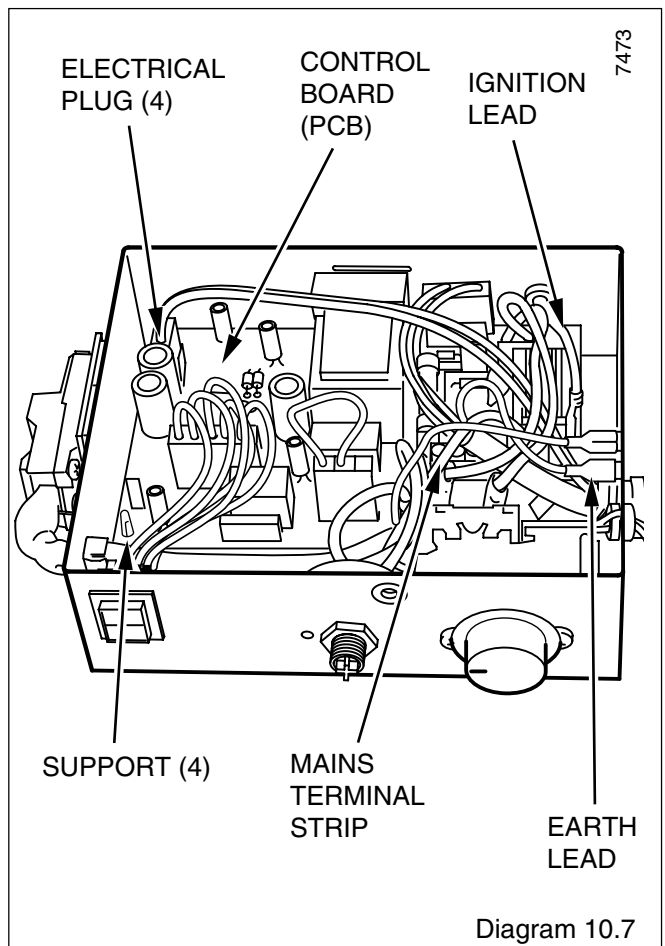
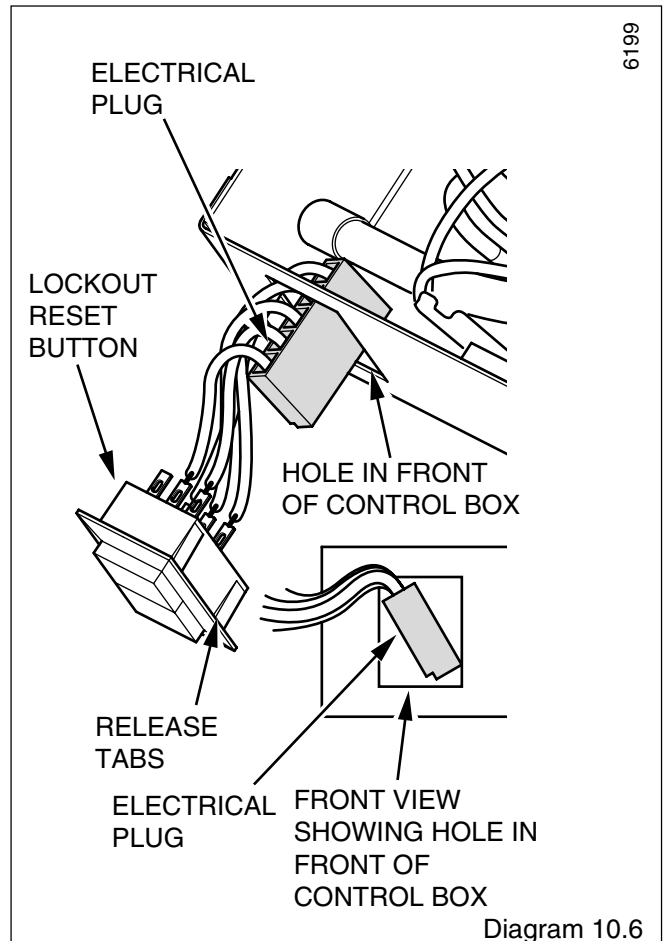
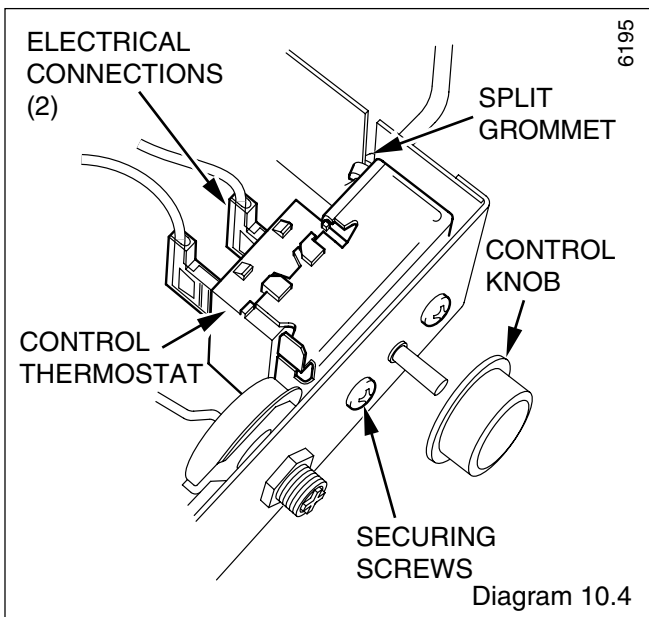

10 Replacement of Parts

Take care to make sure that the hook at the back of the lid hooks onto the control box before fitting the securing screw.

The capillary tube must not touch any part of the back boiler that becomes hot, re-clip the capillary tube and push the phial into the pocket.

NOTE: When fitting the phial use heat sink compound.

When refitting refer to diagram 5.4.

10.9 Lockout Reset Button

Remove the control box lid, see diagram 10.3.

Remove the lockout reset button electrical plug from the control board, release the tabs to remove the lockout reset button, see diagram 10.6.

NOTE: Turn the electrical plug and carefully ease through the hole in the front of the control box as shown in diagram 10.6.

When refitting refer to the wiring diagram 5.6.

10.10 Control Board (PCB)

Remove the control box lid, see diagram 10.3.

Refer to diagram 10.7.

Disconnect the ignition lead.

Disconnect the electrical connections from the control thermostat.

Disconnect the four electrical plugs.

Disconnect the earth lead.

Release the wires from the mains terminal strip.

Carefully pull the board from its supports.

When refitting refer to the wiring diagram 5.6.

10.11 Over Heat Cut-off Device (Sealed systems only)

Remove the over heat phial and unclip the capillary tube, see diagram 5.4.

Remove the control box lid, see diagram 10.3.

Remove the locknut, see diagram 10.8.

Remove the over heat electrical connections, see diagram 10.8.

Remove the over heat cutoff device and capillary from the cut out slot, see diagram 10.8.

NOTE: When refitting, the capillary should pass through the cut out slot on the control box, see diagram 10.8.

When refitting refer to the wiring diagram 5.6.

Take care make sure that the hook at the back of the control box lid hooks into the slot on the control box before refitting the securing screw.

The capillary tube must not touch any part of the back boiler that becomes hot, re-clip the capillary tube and push the phial into either pocket on the 22mm copper pipe.

10.12 Solenoids

Refer to diagram 10.9.

Remove the fire front gas service cock.

Remove the support plate.

Remove the gas control plug at the gas control valve.

Remove the solenoid securing screw.

Remove the solenoids.

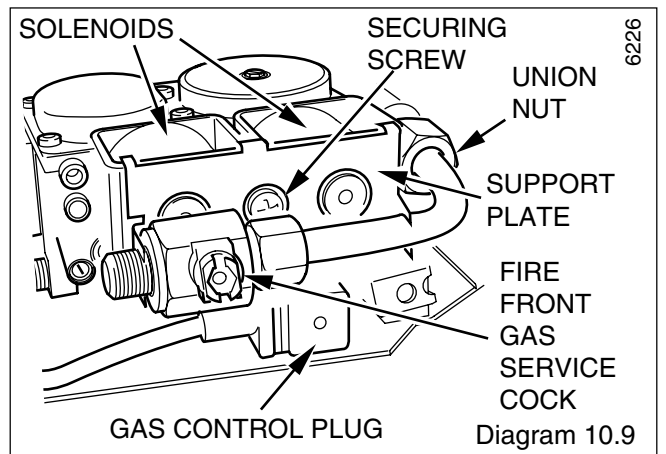
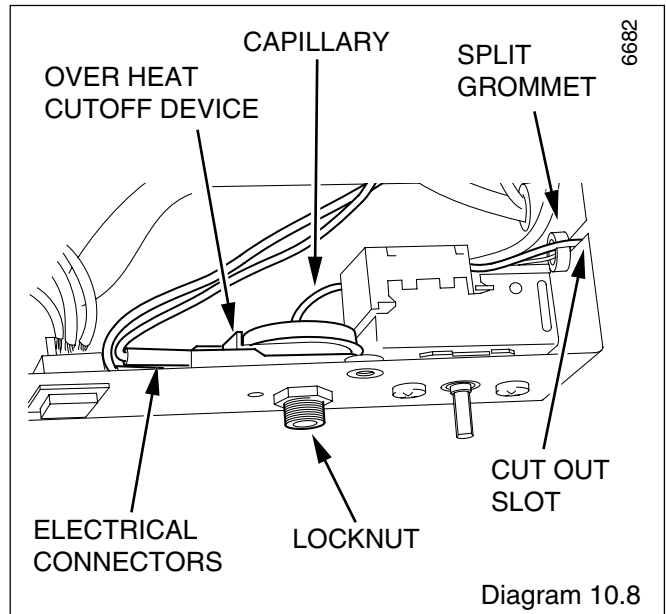

10 Replacement of Parts

10.13 Interrupter

Refer to diagram 10.10.

Carefully disconnect the thermocouple nut.

Remove the electrical connections.

Remove the interrupter.

10.14 Insulation

Follow the relevant instructions in Section 8.3 to remove the controls assembly and burner.

Remove the three burner securing screws to remove the combustion chamber front cover from the controls assembly and burner, see diagram 8.2.

Refer to diagram 10.11.

Remove the front cover insulation,

Slide out the side insulation pieces.

With the side insulation pieces removed, lift out the rear insulation.

Note: Remove any debris that falls when the insulation has been replaced.

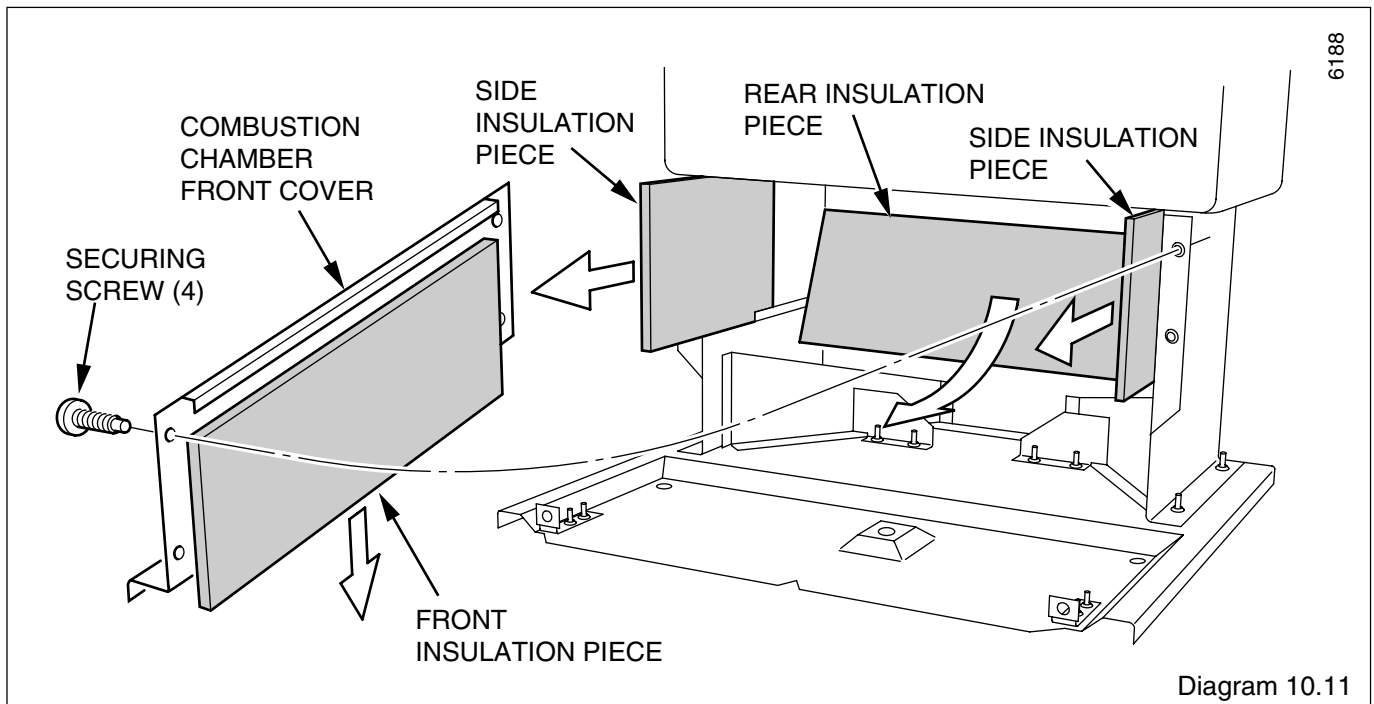
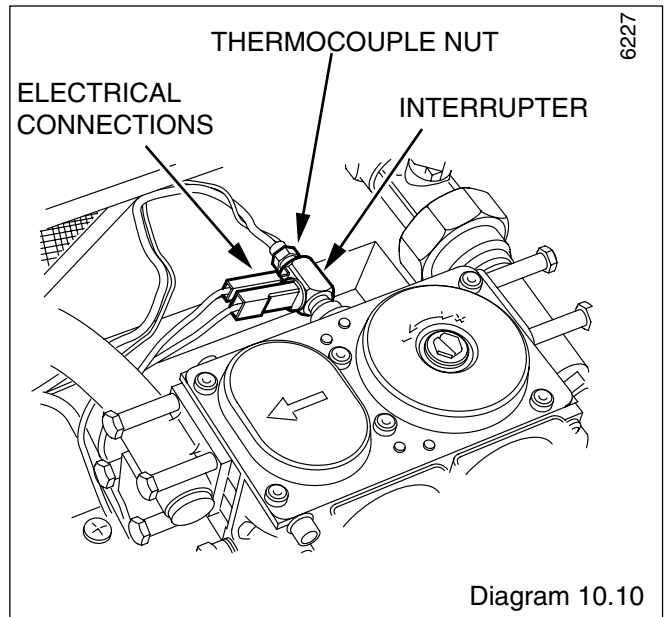

11 Spare Parts

When spare parts are required apply to your local supplier.

Please quote the name of the appliance, Glow-worm Inset BBU 50, with a Dovedale or Chatsworth BBU Fire Front, also the serial number of the boiler, to be found on the data label on the appliance.

If ordering from the local gas undertaking the appropriate appliance GC number should also be quoted together with the GC number of the part.

Key No.	Part No.	Description	GC Part No.
1	WX5501	Ignition lead	*****
2	800929	Gas control valve	E03 982
3	800930	Injector	E03 980
4	202015	Fuse	334 750
5	227009	Control board (PCB)	E26789
6	451477	Flue blockage safety device - SIT Ref: 9403	191 310
7	202577P	Lock out reset button	E04 330
8	202580	Control thermostat	E26792
9	800928	Control knob	E03 970
10	800999	Overheat cut off device	E03 997
11	801002	Flue blockage safety device 'O' Rings	E04 001
12	208693	Sensing Tube Filter	E03 987

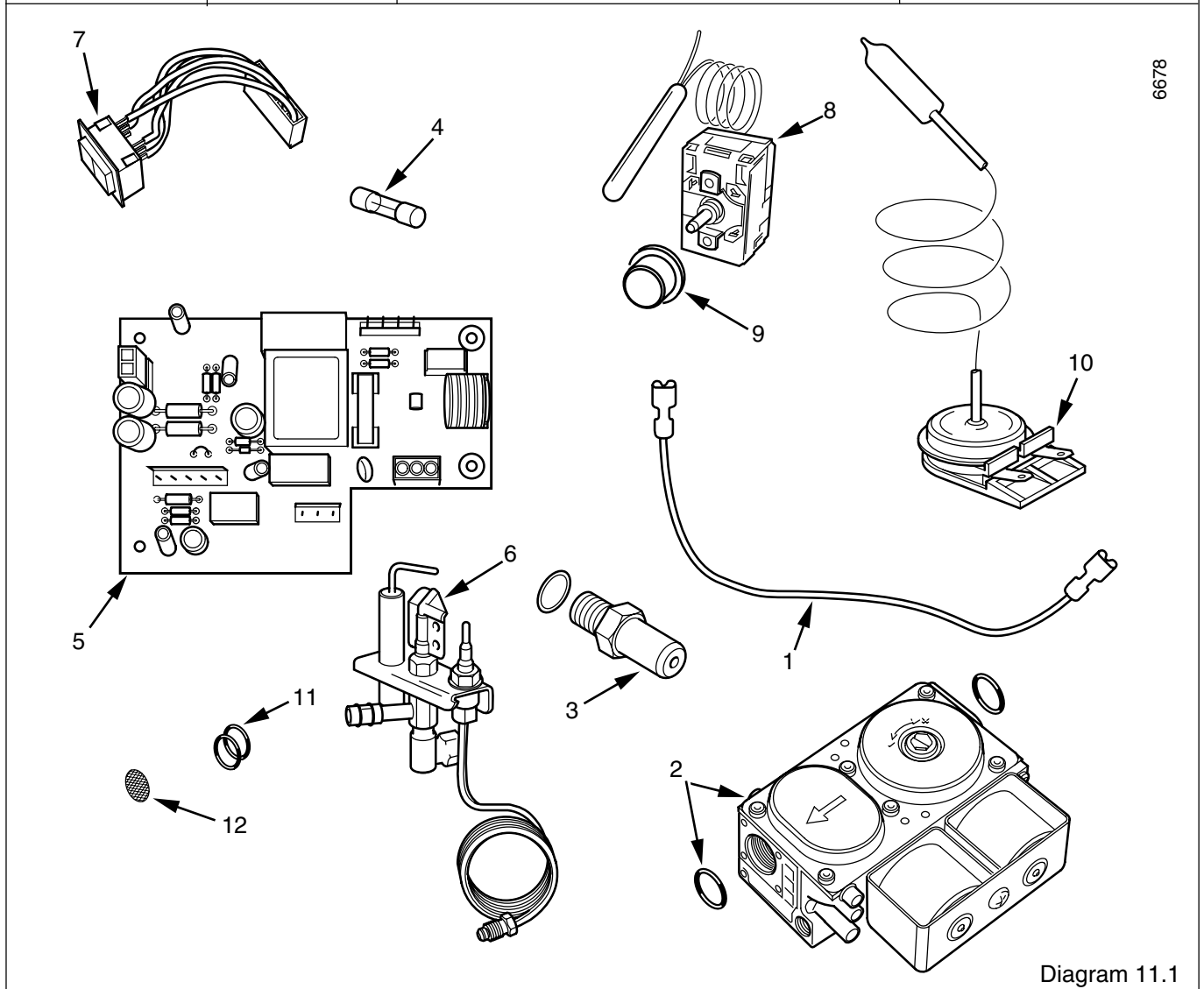

Because of our constant endeavour for improvement details may vary slightly from those in the instructions.