

# Instructions for Use Installation and Servicing

To be left with the user

## Hideaway 80B FF

G.C. No. 41-047-35

*Balanced  
Fanned Flue Boiler*



The mark of quality for domestic heating

This is a Cat I<sub>2H</sub> Appliance

Reference in these instructions to British Standards and Statutory Regulations/Requirements apply only to the United Kingdom. For Ireland the rules in force must be used.

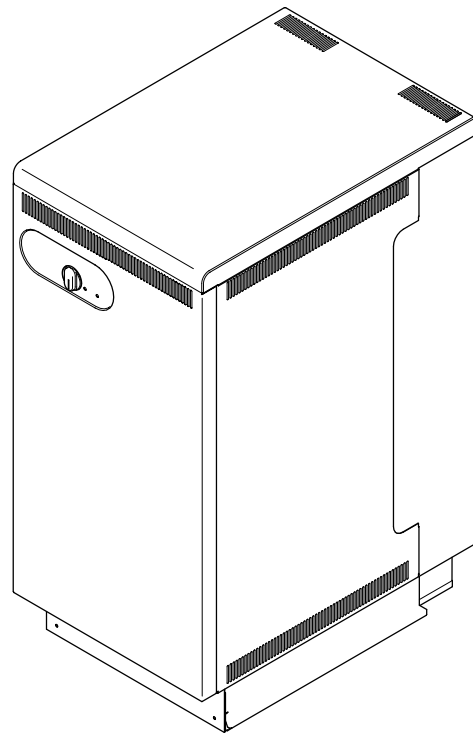

9919

*The instructions consist of three parts, User, Installation and Servicing Instructions, which includes the Guarantee Registration Card. The instructions are an integral part of the appliance and must, to comply with the current issue of the Gas Safety (Installation and Use) Regulations, be handed to the user on completion of the installation.*

### Guarantee Registration

Thank you for installing a new Glow-worm appliance in your home.

Glow-worm appliances' are manufactured to the very highest standard so we are pleased to offer our customers' a Comprehensive First Year Guarantee.

In the centre pages are to be found your Guarantee Registration Card, which we recommend you complete and return as soon as possible.

If this card is missing you can obtain a copy or record your registration by telephoning the Heatcall Customer Service number 01773 828100.

Our Guarantee gives you peace of mind plus valuable protection against breakdown by covering the cost of:

- All replacement parts**
- All labour charges**
- All call-out charges**

REGISTER YOUR GLOW-WORM APPLIANCE  
FOR 1ST YEAR GUARANTEE PROTECTION

**CALL 0208 247 9857**

**HEATCALL**

Customer Services:

Tel: (01773) 828100

**One Contact Local Service** Fax: (01773) 828070

**Hepworth Heating Ltd.,**

Nottingham Road, Belper, Derbyshire. DE56 1JT

**General/Sales enquiries:**

Tel: (01773) 824141 Fax: (01773) 820569

## Important Information

### TESTING AND CERTIFICATION

This boiler is tested and certificated for safety and performance. It is therefore important that no alteration is made to the boiler, without permission, in writing, from Hepworth Heating Ltd.

Any alteration not approved by Hepworth Heating Ltd., could invalidate the certification, boiler warranty and may also infringe the current issue of the Statutory Requirements, see Section 1.3.

### CE MARK

This boiler meets the requirements of Statutory Instrument No. 3083 The boiler (Efficiency) Regulations, and therefore is deemed to meet the requirements of Directive 92/42/EEC on the efficiency requirements for new hot water boilers fired with liquid or gaseous fuels.

Type test for purposes of Regulation 5 certified by: Notified body 0086.

Product/production certified by: Notified body 0086.

The CE mark on this appliance shows compliance with:

1. Directive 90/396/EEC on the approximation of the laws of the Member States relating to appliances burning gaseous fuels.
2. Directive 73/23/EEC on the harmonization of the Laws of the Member States relating to the electrical equipment designed for use within certain voltage limits.
3. Directive 89/336/EEC on the approximation of the Laws of the Member States relating to electromagnetic compatibility.

### INFORMATION FOR THE INSTALLER AND SERVICE ENGINEER.

Under Section 6 of The Health and Safety at Work Act 1974, we are required to provide information on substances hazardous to health.

Ceramic fibre/Insulation Pads, Glassyarn

These can cause irritation to skin, eyes and the respiratory tract. If you have a history of skin complaint you may be susceptible to irritation. High dust levels are usual only if the material is broken. Normal handling should not cause discomfort, but follow normal good hygiene and wash your hands before eating, drinking or going to the lavatory. If you do suffer irritation of the eyes or severe irritation to the skin seek medical attention.

### SPARE PARTS

REMEMBER, when replacing a part on this appliance, use only spare parts that you can be assured conform to the safety and performance specification that we require. Do not use reconditioned or copy parts that have not been clearly authorised by Hepworth Heating Ltd.

### MANUAL HANDLING GUIDANCE

During the appliance installation and the replacement of the heat exchanger it will be necessary to employ caution and assistance whilst lifting as the appliance or component exceeds the recommended weight for a one man lift.

In certain situations it may be required to use a mechanical handling aid.

Take care to avoid trip hazards, slippery or wet surfaces.

CONTENTS	DESCRIPTION	SECTION	PAGE No.
<b>INSTRUCTIONS FOR USE</b>	Introduction		3
	Lighting the Boiler		4
<b>INSTALLATION INSTRUCTIONS</b>	General Data	1	5
	Water Systems	2	7
	Flue & Ventilation	3	9
	Installation	4	10
	Electrical Wiring	5	17
	Commissioning	6	18
	Instructions to User	7	20
<b>SERVICING INSTRUCTIONS</b>	Servicing	8	20
	Fault Finding	9	23
	Replacement Parts	10	26
	Spare Parts	11	28

# Instructions for Use

## Introduction

Please read these instructions and follow them carefully for the safe and economical use of your boiler.

The Glow-worm Hideaway B FF series are balanced flued boilers. They provide heating and if required, an indirect domestic hot water supply.

The boiler is automatic in operation, having only one user control, the boiler temperature control.

## Gas Safety (Installation and Use) Regulations

In your own interests and that of safety, it is the law that ALL gas appliances are installed by a competent person in accordance with the current issue of the above regulations.

## WARNINGS

### Gas Leak or Fault

If a gas leak fault exists or is suspected the boiler must be turned off, including the electrical supply and must not be used until the fault has been put right. Advice/help should be obtained from the local gas undertaking or your installation/servicing company.

### Clearances

Make sure that nothing obstructs the ventilation grills or clearances.

Minimum clearances must be left around the boiler as shown in diagrams 1.4, 1.5 & 1.6.

### Sheet Metal Parts

This boiler contains metal parts (components) and care should be taken when handling and cleaning, with particular regard to edges.

## Cleaning

Keep the casing clean by wiping it occasionally with a damp soapy cloth and dry with a polishing cloth.

Do not use abrasive cleaners.

## Boilers Installed in a Compartment

If the boiler is fitted in a compartment, cupboard etc., do not obstruct the purpose built compartment vents or the grill on the boiler.

Do not use the compartment for storage purposes.

## Maintenance

To ensure the continued efficient and safe operation of the boiler it is recommended that it is checked and serviced as necessary at regular intervals. The frequency of servicing will depend upon the particular installation conditions and usage, but in general once a year should be enough.

It is the law that servicing must be carried out by a competent person.

If this appliance is installed in a rented property there is a duty of care imposed on the owner of the property by the current issue of the Gas Safety (Installation and Use) Regulations, Section 35.

To obtain service please call your installer or Heatcall (Glow-worm's own service organisation) using the telephone number given on the inside of the front panel.

Please be advised that the 'Benchmark' logbook should be completed by the installation engineer on completion of commissioning and servicing.

All CORGI Registered Installers carry a CORGI ID card, and have a registration number. Both should be recorded in your boiler Logbook. You can check your installer is CORGI registered by calling CORGI direct on :- 01256 372300.

## Boiler Electrical Supply

THIS BOILER MUST BE EARTHED.

The boiler must only be connected to a 230V~50Hz supply protected by a 3A fuse, maximum.

All wiring must be in accordance with the current issue of BS7671.

Heat resistant flexible cable having a conductor size of 0.75mm<sup>2</sup>, to the current issue of BS6500 Table 16 must be used.

## To Connect an Electrical Plug

The standard colours of three core flexible cable are, Brown - live, Blue - neutral, Green and Yellow - earth.

As the markings on your plug may not correspond with these colours, continue as follows:

The Blue cable must be connected to the terminal marked "N" or "Black".

The Brown cable must be connected to the terminal marked "L" or "Red".

The Green and yellow cable must be connected to the terminal marked "E" or "Green" or the earth symbol (⊥).

## Protection Against Freezing

If the boiler is to be out of use for any period of time during severe weather conditions we recommend the whole system including the boiler, be drained off to avoid the risk of freezing up. If an immersion heater is fitted to the hot water cylinder make sure it is switched off.

## Instructions for Use

### To Turn the Appliance On

Turn the electrical supply on to the boiler and check that all remote controls are calling for heat.

Turn the boiler temperature control clockwise to any position between "0" and "Max", see diagram 1.

"Max" is approximately 82°C (180°F).

The boiler lighting operation is now automatic as follows:

The fan operates and after a short period of time, the spark ignition operates, the solenoid opens, then the burner will light shown by the burner ON neon (green) on the control panel lighting up.

The burner will remain alight until switched off by the control thermostat or any remote control.

Note: If the boiler is turned OFF at the boiler temperature control, wait at least 30 seconds before switching on again.

When the boiler switches off, the burner will go out.

The automatic lighting sequence will operate again when heat is required.

It should be noted that this is a fanned flue appliance and fan operation may be heard.

If the reset neon lights, turn the boiler temperature control to "0" (off), wait 30 seconds, then repeat the lighting instructions.

### To Turn the Appliance Off

For short periods, turn the boiler temperature control fully anti-clockwise to "0" (off).

To relight, turn the boiler temperature control to any position between "0" and "Max".

For longer periods, turn the boiler temperature control fully anti-clockwise to "0" (off) and switch off the electrical supply to the boiler.

To relight follow the lighting sequence given above.

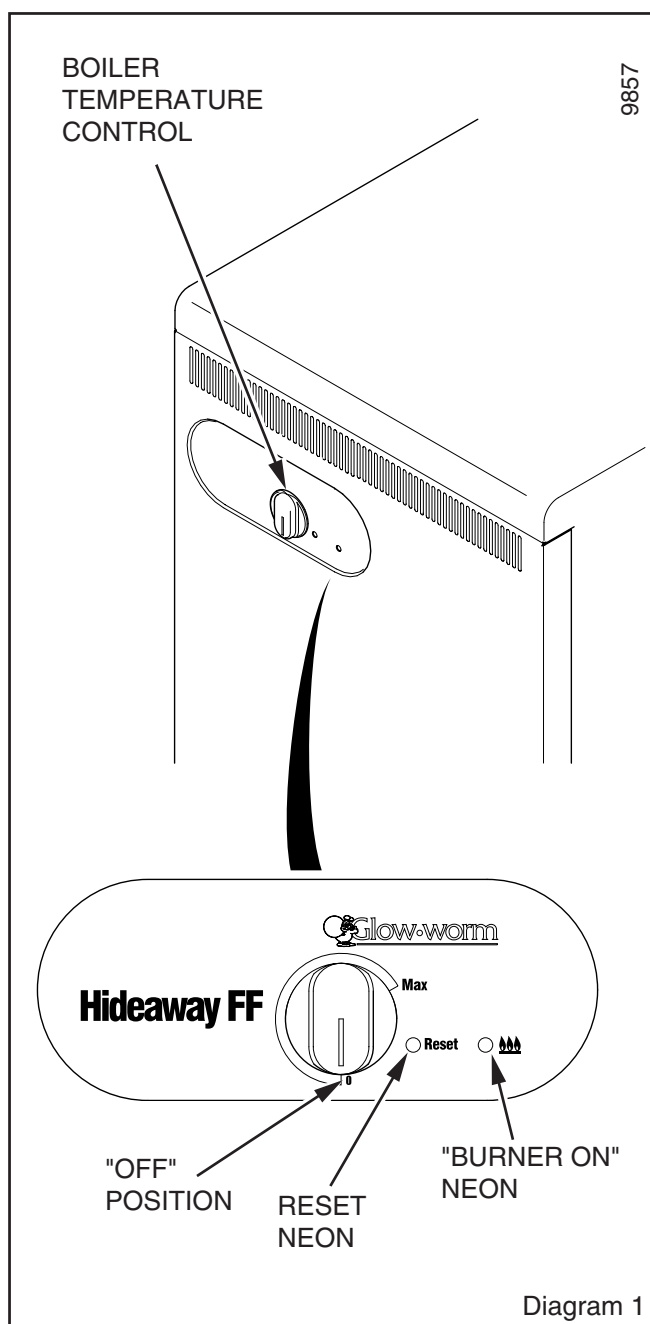

# 1 General Data

⌋ GAS CONNECTION  
Rc 1/2 (1/2 in. B.S.P.T.)

⊕ WATER CONNECTIONS  
Rc1 (1in. B.S.P.T.)

⊙ WATER CONNECTIONS Rc1 reduced  
with DISTRIBUTOR TUBE to  
Rc 3/4 (3/4 in. B.S.P.T.) (pumped return)

NOTE: The boiler casing can be  
set at two heights,  
MAX. and MIN.

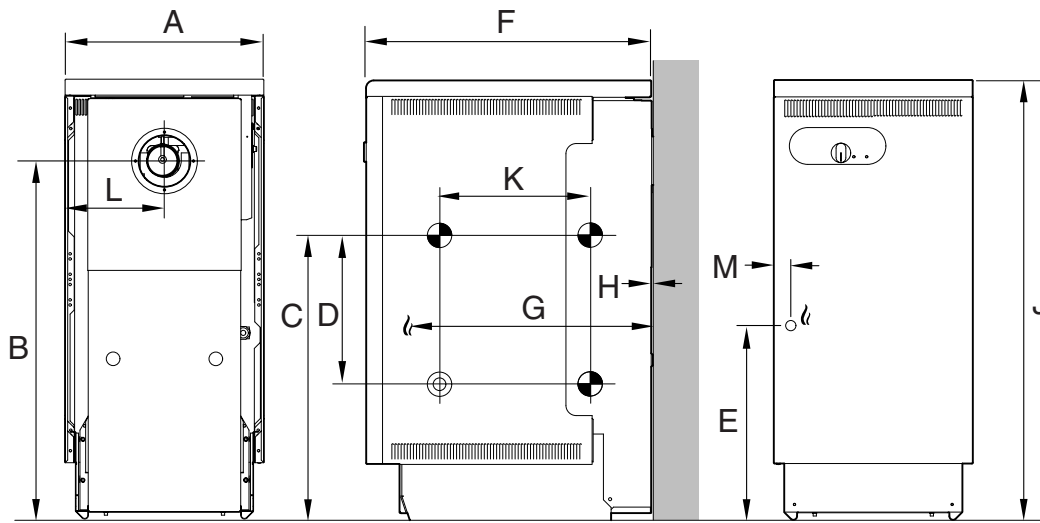

GENERAL DIMENSIONS - given in millimetres

Diagram 1.1

9921

	A	B	C	D	E	F	G	H	J	K	L	M
	387	700	558	294	364	555	442	3	Max 900/ Min 860	300	194	32

## Important Notice

This boiler is for use only on G20 gas.

The boiler is delivered in one pack and the flue pack is supplied separately.

Wherever possible, all materials, appliances and components to be used shall comply with the requirements of applicable British Standards.

Where no British Standard exists, materials and equipment should be fit for their purpose and of suitable quality and workmanship.

Refer to Manual Handling Operations, 1992 Regulations.

## Sheet Metal Parts

WARNING. When installing or servicing this boiler, care should be taken to avoid any possibility of personal injury when handling the edges of sheet metal parts.

## 1.1 Technical Data

See diagrams 1.1 & 1.2.

All dimensions are given in millimetres (except as noted).

**Approximate weight of complete boiler :** 131.5kg (290lb)

**Water content :** 5.76 litre (1.27gallons)

**Gas connection :** Rc1/2 (1/2in BSPT)

**Water connection :** Rc1 (1in BSPT)

**Electrical supply :** 230V~50Hz, fused 3A

**Burner :** Aeromatic

The Seasonal Efficiency Domestic Boilers UK (SEDBUK) is 'D' 78.6%.

The value is used in the UK Government's Standard Assessment Procedure (SAP) for energy rating of dwellings. The test data from which it has been calculated have been certified by B.S.I.

## 1.2 Range Rating

See diagram 1.2.

		HEPWORTH HEATING LTD., BELPER, DERBYS. DE56 1JT	
<b>HIDEAWAY 80B FF</b>		2000461940	
Electrical Supply 230V ~ 50Hz	49W Fused at 3A	GC No.41-047-35	TYPE : C12
For use on I <sub>2H</sub> G20- 20mbar.		NOx Class 1	
This boiler is intended exclusively to be installed on a gas supply with a governed meter.		CE 0086	
		GB IE	
HEATING CIRCUIT PMS = 2.5 bar		0086/A0/027	
INJECTOR: 4.4mm PART No. 2000461924			
HOT BURNER PR - mbar (in.w.g)		11.8 (4.7)	
HEAT INPUT NETT Q- kW (Btu/h)		25.94(88,507)	
HEAT OUTPUT P- kW (Btu/h)		23.45(80,000)	
SERIAL No.			

Diagram 1.2

10121

# 1 General Data

## 1.3 Statutory Requirements

The installation of this appliance must be carried out by a competent person and must be in accordance with the relevant requirements of the current issue of:

Manufacturer's instructions supplied.

The Gas Safety (Installation and Use) Regulations, Building Regulations, Local Water Company Bye-laws, The Building Standards (Scotland) Regulations, (applicable in Scotland), Health and Safety at Work Act, Control of Substances Hazardous to Health, Electricity at Work Regulations and any applicable local regulations.

Detailed recommendations are contained in the current issue of the following British Standards and Codes of Practice,

BS6891, BS5440 Part 1 and 2, BS6798, BS5449, BS5546, BS6700, BS7478, BS7593, BS7671.

Manufacturer's instructions must not be taken as overriding statutory requirements.

## 1.4 B.S.I Certification

This boiler is certificated by B.S.I., for safety and performance. It is, therefore, important that no alteration is made to the boiler unless agreed, in writing, by Hepworth Heating Ltd.

Any alteration not approved by Hepworth Heating Ltd., could invalidate the B.S.I. certification, boiler warranty and could infringe the current issue of the Statutory Requirements.

## 1.5 Gas Supply

The gas installation should be fitted in accordance with the current issue of BS6891.

The supply from the governed meter must be of adequate size to provide a steady inlet working pressure of 20mbar (8in wg) at the boiler.

On completion test the gas installation using the pressure drop method and suitable leak detection fluid, purge in accordance with the current issue of BS6891.

## 1.6 Electrical

**WARNING.** This boiler must be earthed.

The electrical installation must be carried out by a competent person. All external components shall be of the approved type and shall be connected in accordance with the current issue of BS7671 and any local regulations which apply.

Connection of the boiler and any system controls to the mains supply through an unswitched shuttered socket outlet and 3A fused 3 pin plug, both to the current issue of BS1363. Alternatively, a 3A fused double pole isolating switch may be used, having a minimum double pole contact separation of 3mm, serving only the boiler and system controls.

Heat resistant cable of at least 0.75mm<sup>2</sup> (24/0.20mm), to the current issue of BS6500 Table 16, must be used for all connections within the boiler casing, to the control box, pump etc.

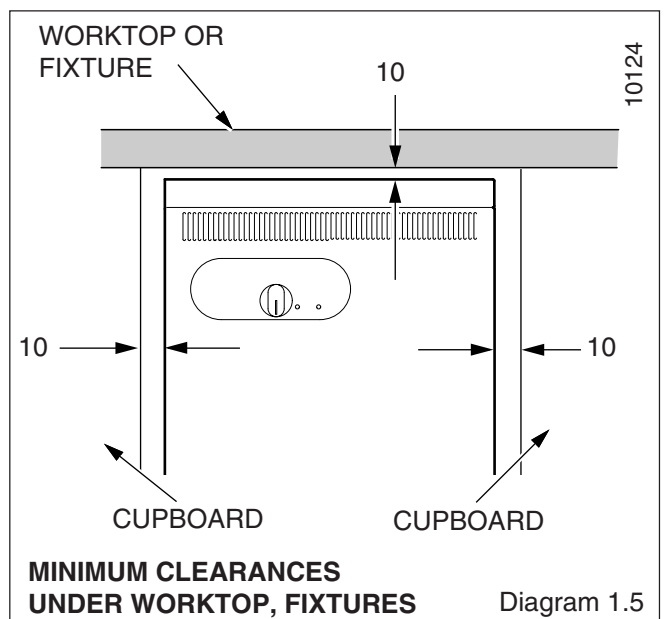
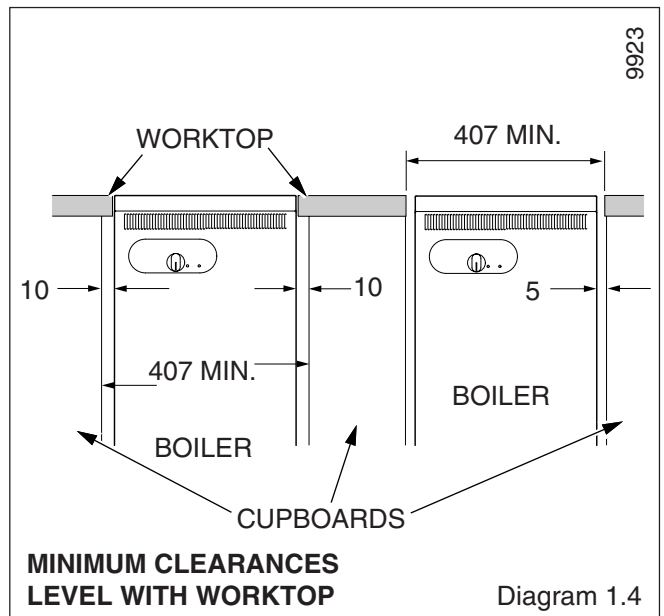
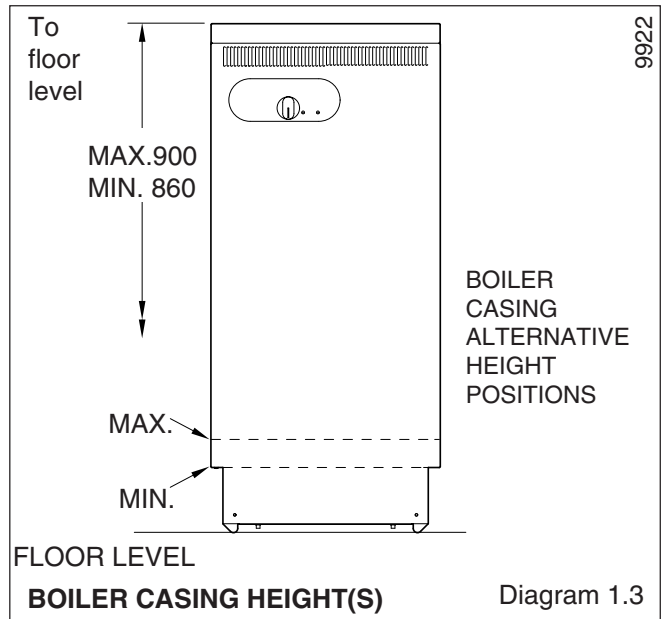

# 1 General Data

## 1.7 Boiler Location

This boiler is not suitable for outside installation.

The boiler casing can be fitted at two heights. Refer to diagram 1.3.

The boiler is assembled at the factory with the control box and heat shield fitted in the lower position.

The boiler must stand on a level floor, conforming with local authority requirements and building regulations.

The base temperature is within the requirements of the current issue of BS5258. The boiler may stand on a wooden floor but a metal base plate is required to protect plastic tiles and similar floor coverings.

Suitable installation clearance needs to be available at the sides of the boiler to facilitate direct connection of pipework and making good around the flue assembly. The actual clearance required will vary with site conditions.

When the boiler is to be installed level with work surfaces and the like, minimum clearances should be provided as shown in diagram 1.4. Work tops which overhang the cupboard sides, almost in contact with the casing top, require a larger minimum air gap. Flush sided fixtures require the same overall minimum space but can have a reduced air gap on one side.

Boilers to be installed under work tops or fixtures, should be positioned to provide minimum clearances as shown in diagram 1.5. To facilitate minimum clearances it may be necessary to modify kitchen units and fixtures.

A front access clearance should be provided as shown in diagram 1.6.

The boiler may be installed in any room, although particular attention is drawn to the requirements of BS7671 with respect to the installation of a boiler in a room containing a bath or shower. Any electrical switch should be so positioned that it cannot be touched by a person using the bath or shower. The electrical provisions of the Building Standards (Scotland) Regulations apply to such installations in Scotland.

Where the installation of the boiler will be in an unusual location, special procedures are necessary the current issue of BS6798 gives detailed guidance on this aspect.

A compartment used to enclose the boiler must be designed and constructed specifically for this purpose. An existing cupboard or compartment modified for the purpose may be used. Details of essential features of cupboard or compartment design are given in the current issue of BS6798.

If the boiler is to be installed in a compartment, make sure that nothing will obstruct the openings/vents in the compartment.

## 1.8 Heating System Controls

The heating system should have installed: a programmer and room thermostat controlling the boiler.

Thermostatic radiator valves may be installed, however they must not be fitted in a room where the room thermostat is located.

Note: For further information, see the current issue of the Building Regulations, approved document L1, and the references:

1) GIL 59, 2000: Central heating system specification (CheSS) and

2) GPG 302, 2001: Controls for domestic central heating system and hot water. BRECSU.

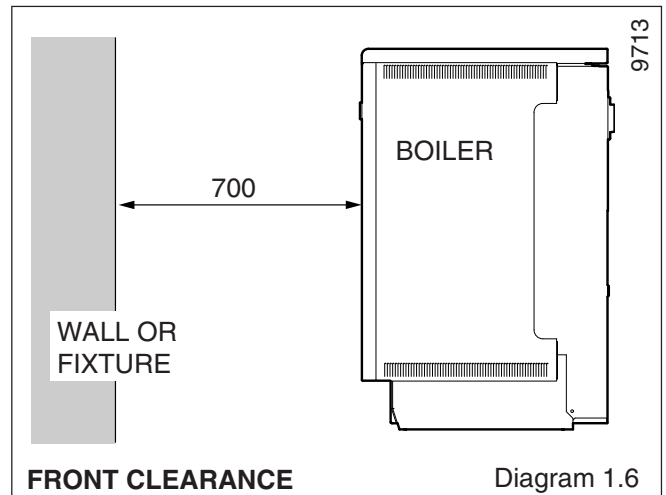

# 2 Water Systems

## 2.1 Water Pressure Head

The boiler shall only be connected to a cistern water supply with a minimum head of 1metre (3ft3in) and a maximum head of 27metres (90ft) which has an open vent in the system.

The working pressure must be within the range 0.1bar to 2.7bar (1.3 to 39lbftin<sup>2</sup>).

The boiler MUST NOT be connected to a sealed water system.

## 2.2 Inhibitor

Attention is drawn to the current issue of BS5449 and BS7593 on the use of inhibitors in central heating systems.

If an inhibitor is to be used in the system, contact should be made with the inhibitor manufacturers so that they can recommend their most suitable product.

When using in an existing system take special care to drain the entire system, including the radiators, then thoroughly clean out before fitting the boiler whether or not adding an inhibitor.

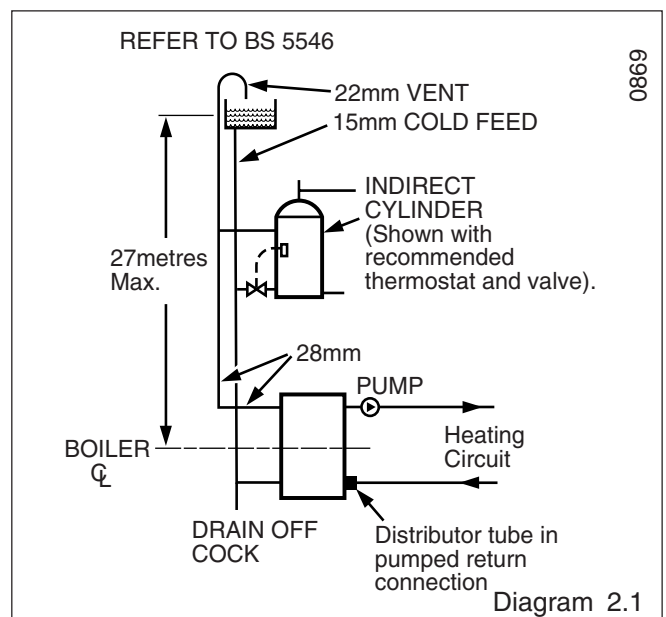

## 2 Water Systems

### 2.3 Gravity Domestic and Pumped Heating

It is recommended that a cylinder thermostat is used to prevent the stored water temperature becoming unnecessarily high when the central heating pump is off.

The domestic primary flow and return must be 28mm o.d. The installation must comply with the current issue of BS5546 and BS6700, see diagram 2.1.

If the above conditions cannot be met, it is suggested that a fully pumped system be used.

### 2.4 Pumped Heating and Hot Water

Where a single flow and return is taken from the boiler, a minimum static head of 1metre (3ft3in) must be provided between the water line of the feed tank and the centre of the waterway, see diagram 2.2.

### 2.5 Circulation Pump

Normally the pump should be set to give a temperature difference of 11°C (20°F) across the boiler. At the appropriate pumped flow rate the pressure loss through the boiler can be found from the graph, diagram 2.3.

Use a pump with integral valves or fit isolating valves as close to the pump as possible.

### 2.6. Cylinder

For all systems supplying domestic hot water the cylinder must be indirect.

### 2.7 Safety Valve

A safety valve need not be fitted to an open vented system.

### 2.8 Draining Tap

A draining tap must be provided at the lowest points of the system which will allow the draining of the entire system, including the boiler and hot water cylinder.

Draining taps should be to the current issue of BS2879.

### 2.9 Thermostatic Radiator Valves

If thermostatic radiator valves are fitted care must be taken to ensure that there is an adequate flow rate through the boiler when they close, refer to the current issue of BS7478 for guidance. If fitted to all radiators ensure a bypass is fitted and adjust to achieve a temperature difference no greater than 20°C between flow and return with the thermostatic valves closed.

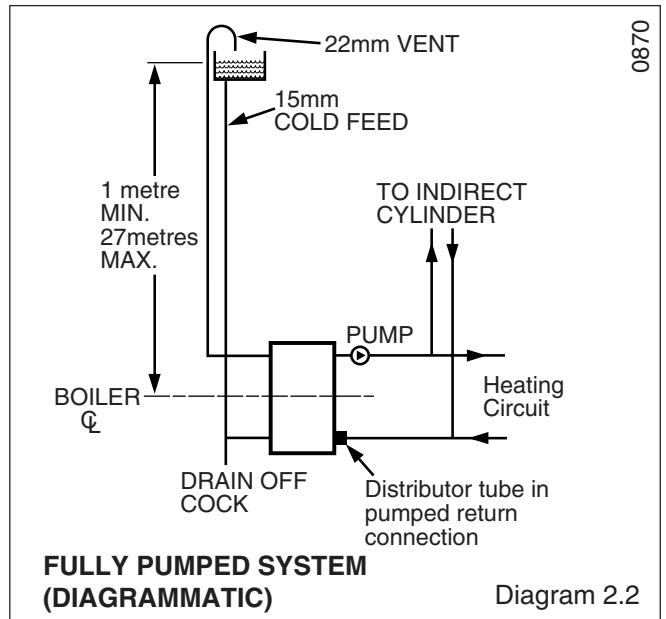

0870

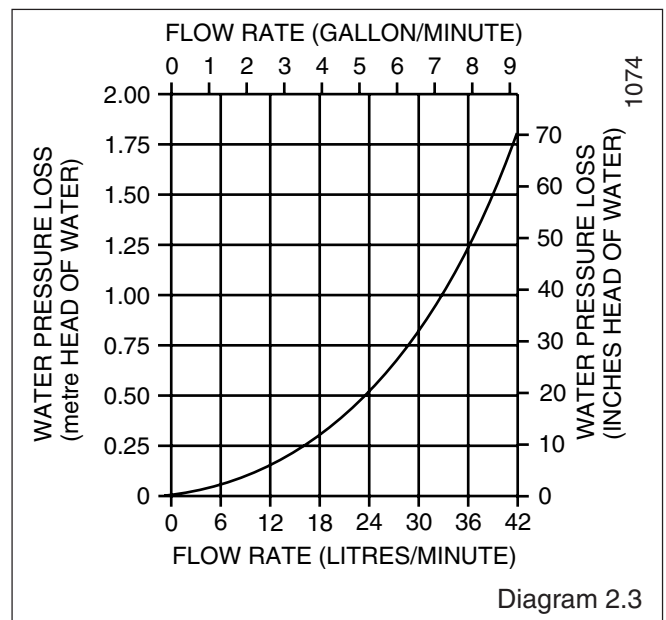

1074

## 3 Flue and Ventilation

The flue must be installed in accordance with the rules in force in the countries of destination.

### 3.1 Terminal Position

The minimum acceptable siting dimensions for the terminal from obstruction, other terminals and ventilation openings are shown in diagram 3.1.

The terminal must be exposed to the external air, the position allowing free passage of air across it at all times.

Car ports or similar extensions of a roof only, or a roof and one wall, require special consideration with respect to any openings, doors, vents or windows under the roof. Care is required to protect the roof if it is made of plastic sheeting. If the car port consists of a roof and two or more walls, seek advice from the local gas company before installing the boiler.

If the terminal is fitted within 600mm below plastic guttering or painted soffit an aluminium shield 1500mm long should be fitted immediately beneath the guttering or eaves. If the terminal is fitted within 450mm below painted eaves or a painted gutter, an aluminium shield 750mm long should be fitted immediately beneath the guttering or eaves.

### 3.2 Timber Frame Buildings

If the boiler is to be installed in a timber frame building it should be fitted in accordance with the Institute of Gas Engineers document IGE/UP/7/1998. If in doubt seek advice from the local gas undertaking or Hepworth Heating Ltd.

### 3.3 Terminal Guard

A terminal guard is required if persons come into contact with the terminal or the terminal could be subject to damage.

If a terminal guard is required, it must be positioned to provide a minimum of 50mm clearance from any part of the terminal and be central over the terminal.

A suitable guard, reference Type "K3", can be obtained from:

Tower Flue Components Ltd.,  
Morley Road, Tonbridge,  
Kent. TN9 1RA

### 3.4 Room Ventilation

The boiler is room sealed and does not require the room or space containing it to have permanent air vents.

### 3.5 Compartment Ventilation

Where the boiler is fitted in a compartment, the high and low level permanent air vents must have effective areas, see "Compartment Air Vent Table".

Both the high and level air vents must communicate with the same room or must both be on the same wall to outside air.

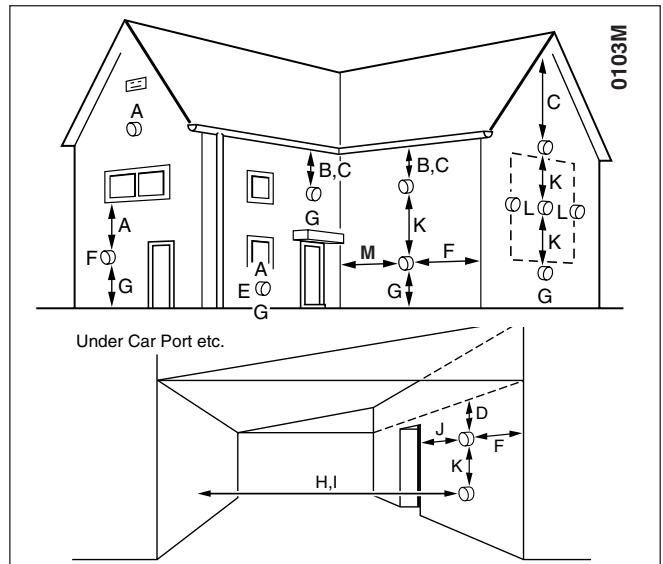

MINIMUM SITING DIMENSIONS FOR FANNED FLUE TERMINALS POSITION MINIMUM SPACING in mm

A DIRECTLY BELOW, ABOVE OR HORIZONTALLY TO AN OPENING, AIR BRICK, OPENING WINDOWS, AIR VENT OR ANY OTHER VENTILATION OPENING.	300
B BELOW GUTTER, DRAIN/SOIL PIPE	25
C BELOW EAVES	25
D BELOW A BALCONY OR CAR PORT	25
E FROM VERTICAL DRAIN PIPES AND SOIL PIPES	25
F FROM EXTERNAL CORNERS	25
G ABOVE ADJACENT GROUND OR BALCONY LEVEL	300
H FROM A SURFACE FACING THE TERMINAL	600
I FACING TERMINALS	1200
J FROM OPENING (DOOR/WINDOW) IN CAR PORT INTO DWELLING	1200
K VERTICAL FROM A TERMINAL	1500
L HORIZONTALLY FROM A TERMINAL	300
M FROM INTERNAL CORNERS	25

Diagram 3.1

COMPARTMENT AIR VENT TABLE				
COMPARTMENT VENTILATION REQUIREMENTS	HIGH LEVEL VENT AREA		LOW LEVEL VENT AREA	
VENTILATION FROM ROOM OR SPACE	272cm <sup>2</sup>	42in <sup>2</sup>	272cm <sup>2</sup>	42in <sup>2</sup>
FROM OUTSIDE	136cm <sup>2</sup>	21in <sup>2</sup>	272cm <sup>2</sup>	42in <sup>2</sup>

## 4 Installation

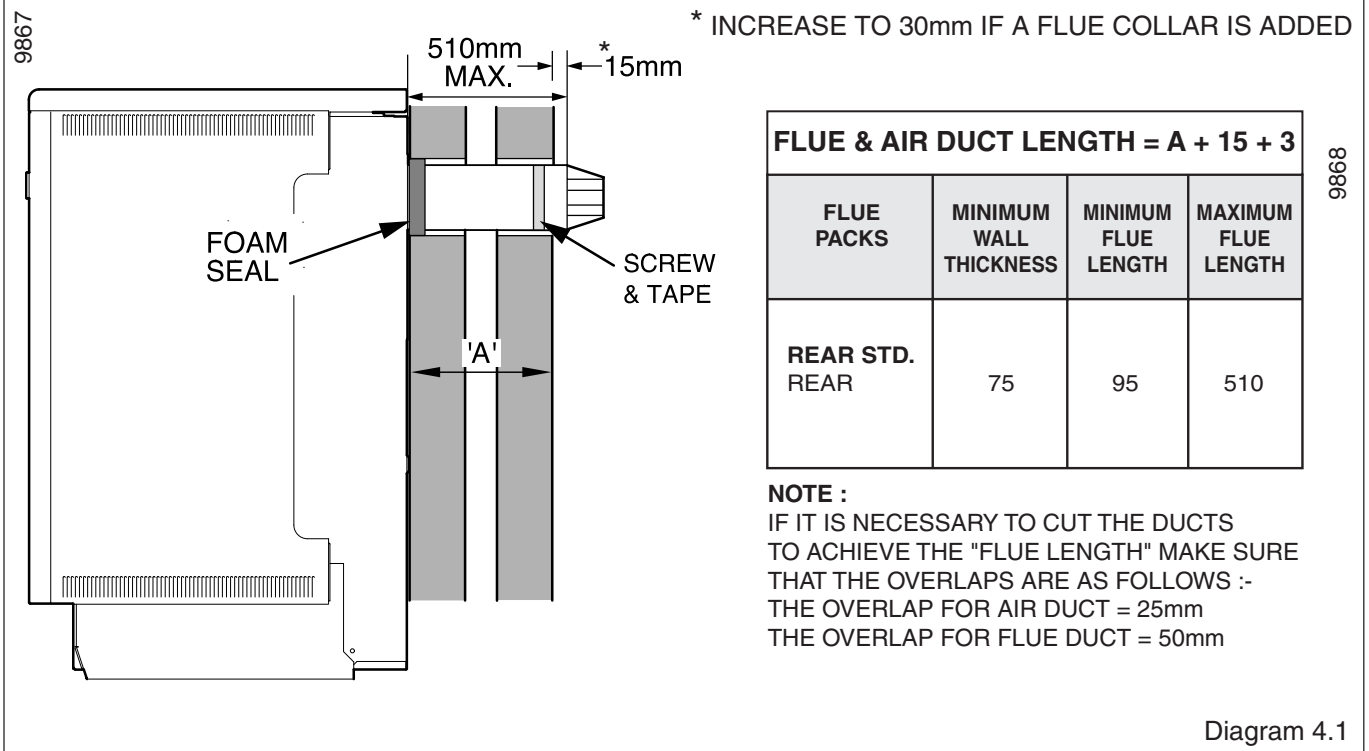

### General Installation Notes

The appliance pack contains :-

- Boiler
- Fan connector
- Casing panels, packed separately.
- Loose items fittings pack, see list in pack.

The flue is supplied separately.

NOTE: The rear flue option kit Part No. 425861 is available, which consists of wall cover plates, for replacement Hideaway balanced flue appliances.

Before installation of the boiler make sure that the location selected is in accordance with the requirements of Section 1.7.

### 4.1 Unpacking

The boiler casing panels are packed separately within the main carton and are designed to enable gas and water connections to be made before fitting the casing panels.

The casing brackets, flue restrictor, distributor tube and other loose items, are in the fittings pack.

#### NOTE:

To make a neat finish to the flue outlet a flue collar kit, part No. 900850, with instructions, is available, see diagram 6.4.

If required an optional wall liner kit, part no. 900862, is available complete with instructions.

All flue assemblies are designed for internal installation.

Make sure that the ductings do not slope down towards the boiler.

### 4.2 Flue Position and Length

Select the boiler location, with due regard to the flue length and terminal position, see diagrams 3.1 and 4.1.

For a wall thickness up to 300mm, provided that the optional wall liner kit is used, the flue can be fully installed from the inside.

For a wall thickness of over 300mm the external flue hole will need to be made good from the outside, this also applies if you use the flue kit without the optional wall liner kit, irrespective of wall thickness.

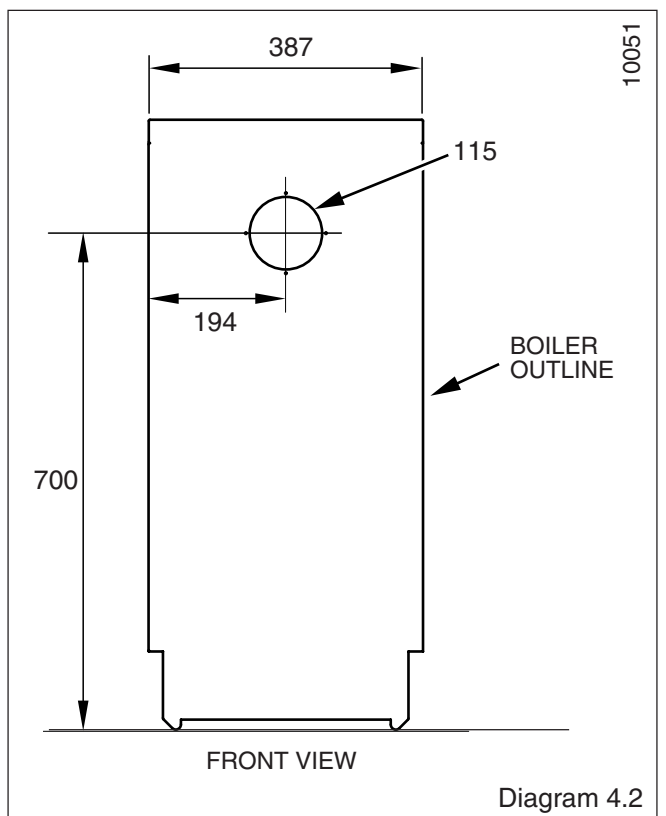

## 4 Installation

### 4.3 Flue Hole Cutting

Mark out the flue centre, see diagram 4.2, then cut a hole for the flue using, preferably, a 115mm minimum core drill.

### 4.4 Rear Flue Option Kit - 425861 (if applicable)

Fit the wall cover plates as described in the instructions supplied with the kit.

### 4.5 Flue Preparation

**Note:** If the flue collar kit, see diagram 4.4, is to be used increase the 15mm projection to 30mm.

Extend the telescopic flue to the required length, making sure that the minimum overlap is no less than 25mm, and that the flue terminal projects 15mm minimum beyond wall face, see diagram 4.1.

If it is necessary to cut the flue ensure that the overlap is as stated in diagram 4.1.

Carefully drill through air duct pilot hole and secure with self tapping screw provided in fittings pack, see diagram 4.3.

Seal the joint with the tape provided.

**Note:** Should any one of the flue sections require cutting to obtain desired flue system length make sure that the overlaps are as follows:-

The overlap for air duct = 25mm

The overlap for flue duct = 50mm.

Take the terminal restrictor and position the clamping bracket making sure the clamping bracket nib protrudes in the slot of the terminal restrictor and secure with locking screw, but do not tighten, see diagram 4.5.

Engage the terminal restrictor on the flue terminal by hooking it over the terminal end and engaging the clamping bracket behind the inner ring of the terminal securing it by tightening the locking screw, see diagram 4.5.

Fit the self adhesive foam seal provided in the flue pack around the air duct at the position shown in diagram 4.6.

Make sure that the ductings do not slope down towards the boiler.

Make good around the flue outside after installation of the boiler.

**Important:** If the wall liner kit is used, the self adhesive foam seal included in the wall liner kit must be used in place of the one supplied with the flue pack, see diagram 4.6 for position of self adhesive seal.

Push the flue assembly into and through the hole such that it is within the wall, and does not stick out into the room. Do not push the flue assembly too far into the hole as it has to be pulled back into the boiler and secured.

If the boiler is not to be fitted for some time cover the hole in the wall.

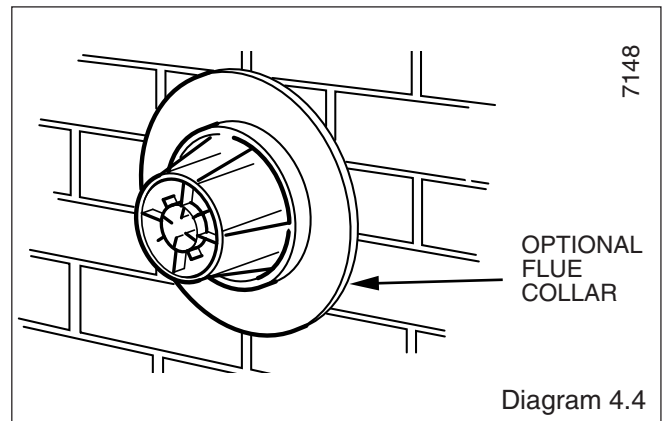

Diagram 4.4

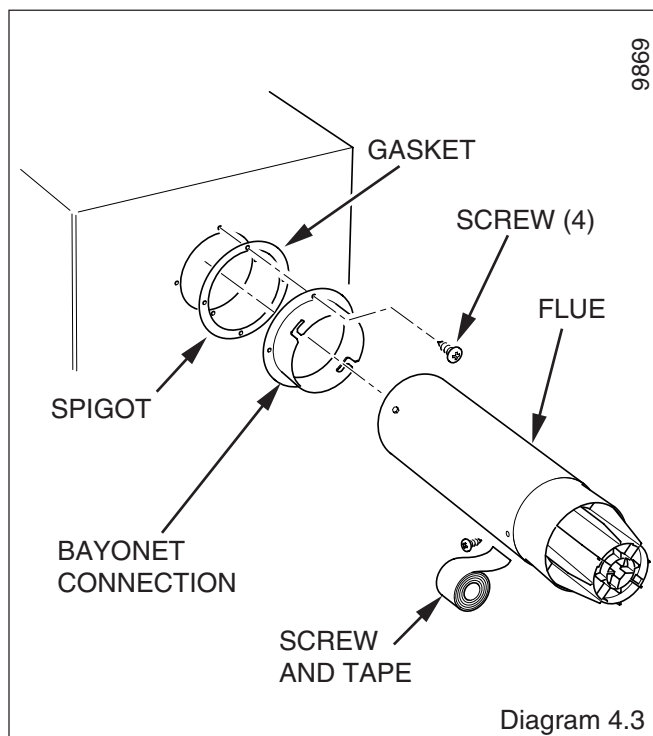

Diagram 4.3

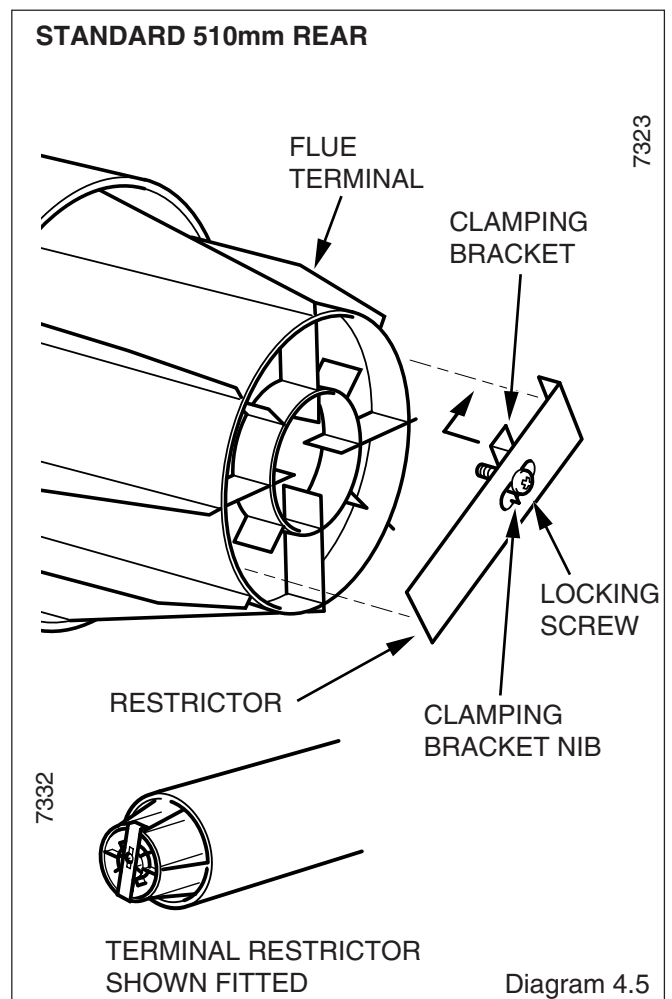

Diagram 4.5

## 4 Installation

### 4.6 Water Connections - Gravity Domestic and Pumped Heating

Fit suitable fittings into the boiler tappings, see diagram 4.7.

Make sure that all pipes are taken backwards and will clear the casings, see diagram 1.1.

Heating flow: Any one of the four upper connections may be used.

Domestic flow: Any one of the three remaining upper connections may be used.

Heating return: The water distributor tube must be fitted into either of the front lower connections on all installations, see diagram 4.8. This tube is in the fittings pack.

Domestic return: Any one of the three remaining lower connections may be used for the gravity domestic hot water return.

Fit plugs into any unused boiler tappings.

### 4.7 Water Connections - Fully Pumped Systems

Fit suitable fittings into the boiler tappings as required, see diagram 4.9. Make sure that all pipes are taken backwards and will clear the casings, see diagram 1.1.

It is important that all connections are made as shown in diagram 4.9.

Fit the water distributor tube into the return connection, see diagram 4.8. This tube is in the fittings pack.

Fit plugs into any unused boiler tappings.

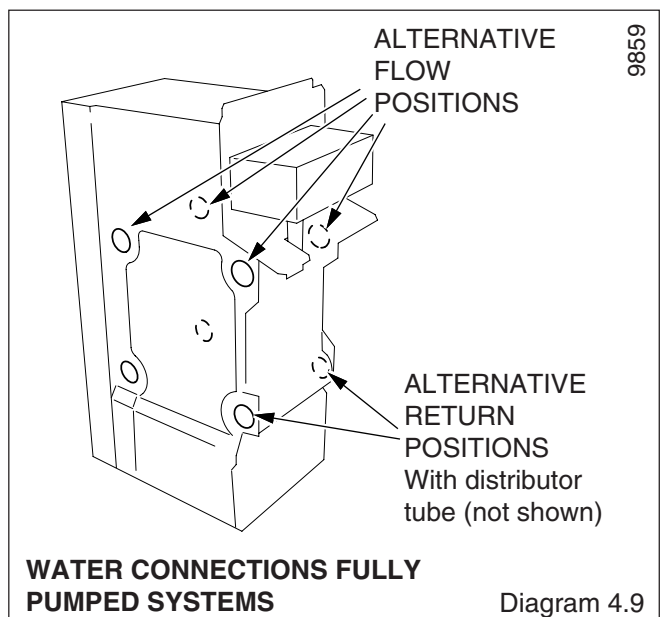
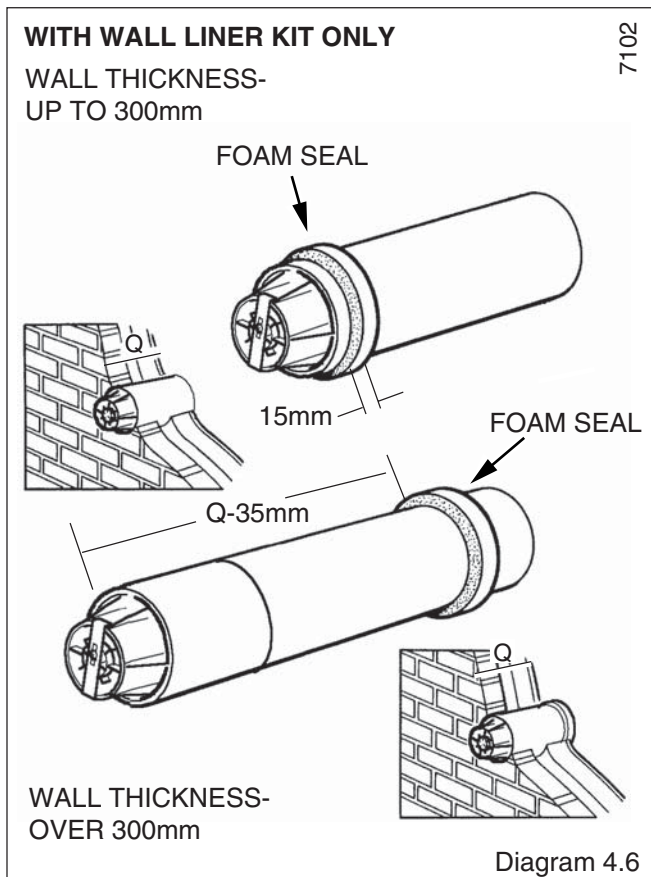
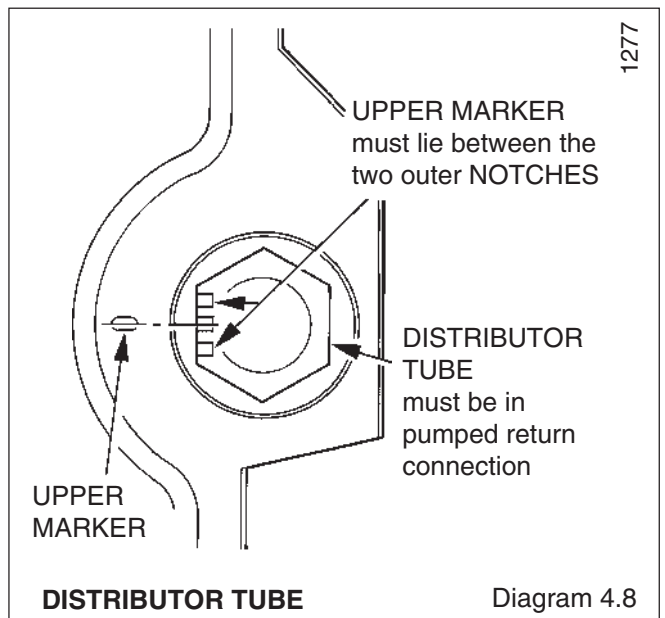
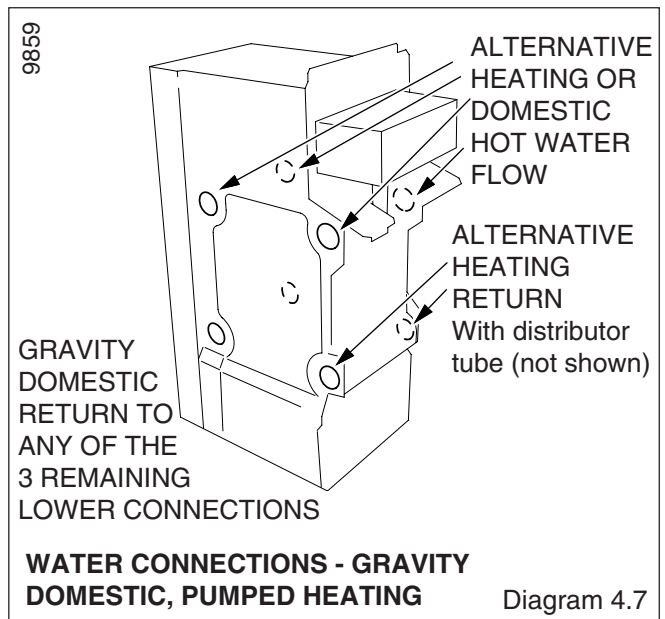

## 4 Installation

### 4.8 Pipework

When the front tapplings are used, it is essential that any pipework or fittings do not project more than shown in diagram 4.10.

When using a rear tapping with Rc (1 in BSP) fitting for 28mm od pipework, it is recommended that a short nipple and an Rc thread (BSP) to copper elbow is used. If the pipework is required to run back to the wall, make sure that it will clear the boiler air duct and, if working to minimum clearance, does not project too far from the boiler, see diagram 4.11.

Do not route any pipework, water or gas, across the front of the combustion chamber cover.

The gas pipework must be along the left hand side of the boiler.

### 4.9 Casing Brackets

Fit the two upper and two front casing brackets shown in diagram 4.12, using the No.8 screws provided.

NOTE: The screws will already be fitted.

Push the captive nuts, supplied loose, on to the casing brackets as shown in diagram 4.12.

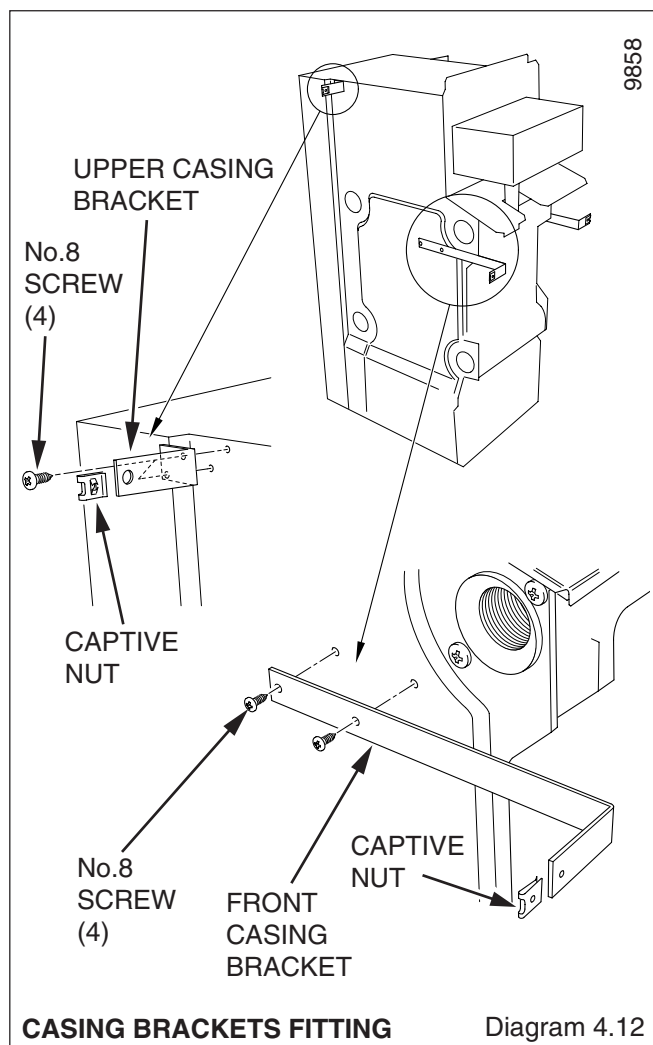
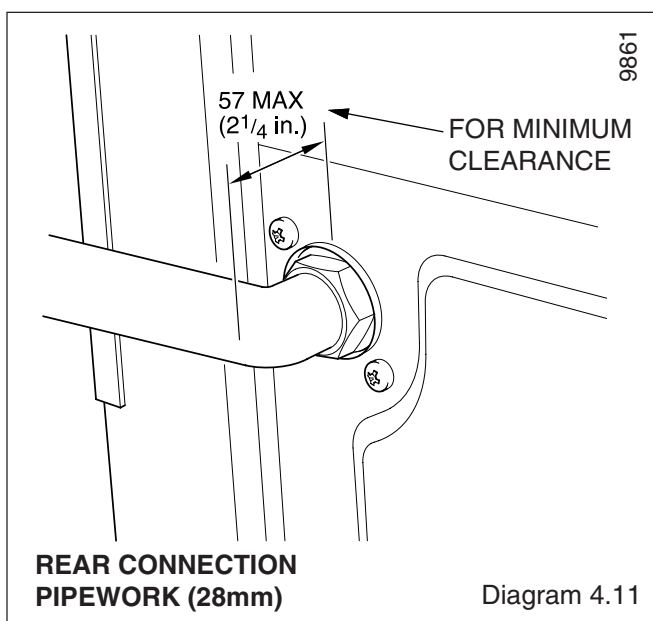
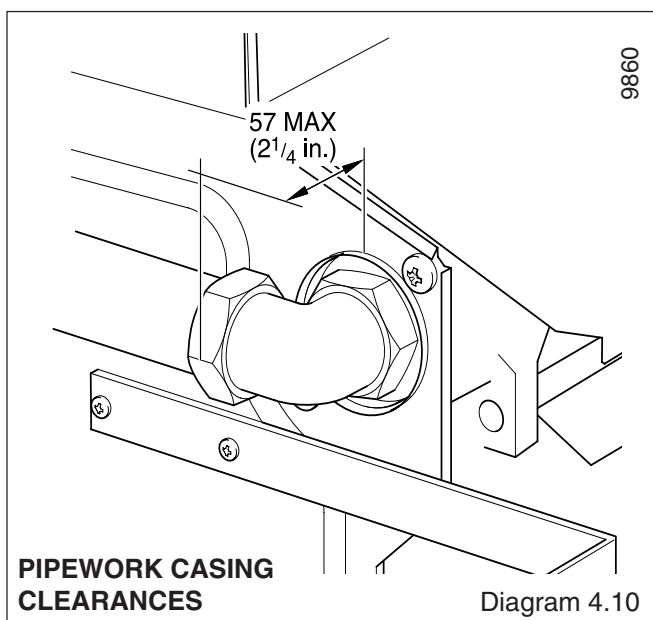

## 4 Installation

### 4.10 Side In-fill Panel (if required)

A side in-fill panel is supplied with the boiler, which can be fitted at the rear of the left or right hand side casing but can be discarded if the water connections are made on both sides of the boiler or if the boiler is screened by fixtures. The in-fill panel will usually be fitted on the side where there are no pipework connections.

Insert the push fit plastic location peg, supplied, through the in-fill panel and side casing holes and secure with the spring clips, see diagram 4.13.

#### NOTE

The boiler is assembled at the factory with the control box and heat shield fitted in the lower casing height position.

### 4.11 Side Casings

Fit the side casings by locating their lugs into the appropriate slot in the boiler plinth, see diagram 4.13, depending on the required height, there are two options, see section 1.7.

Secure the casing sides to the front and rear upper casing brackets with self-tapping screws supplied, see diagrams 4.13 and 4.15.

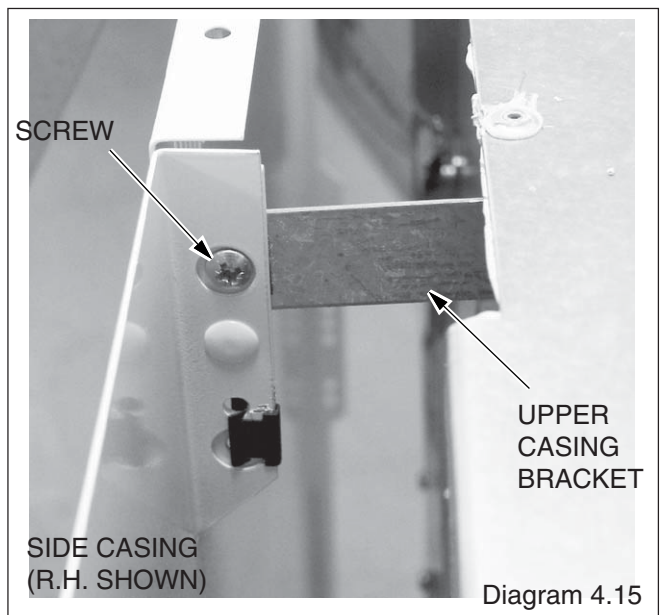
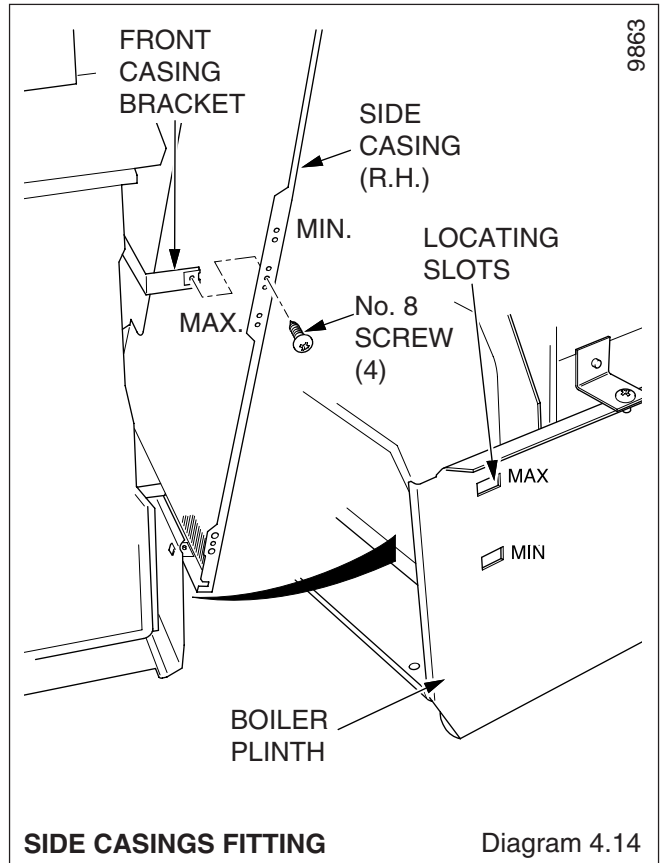
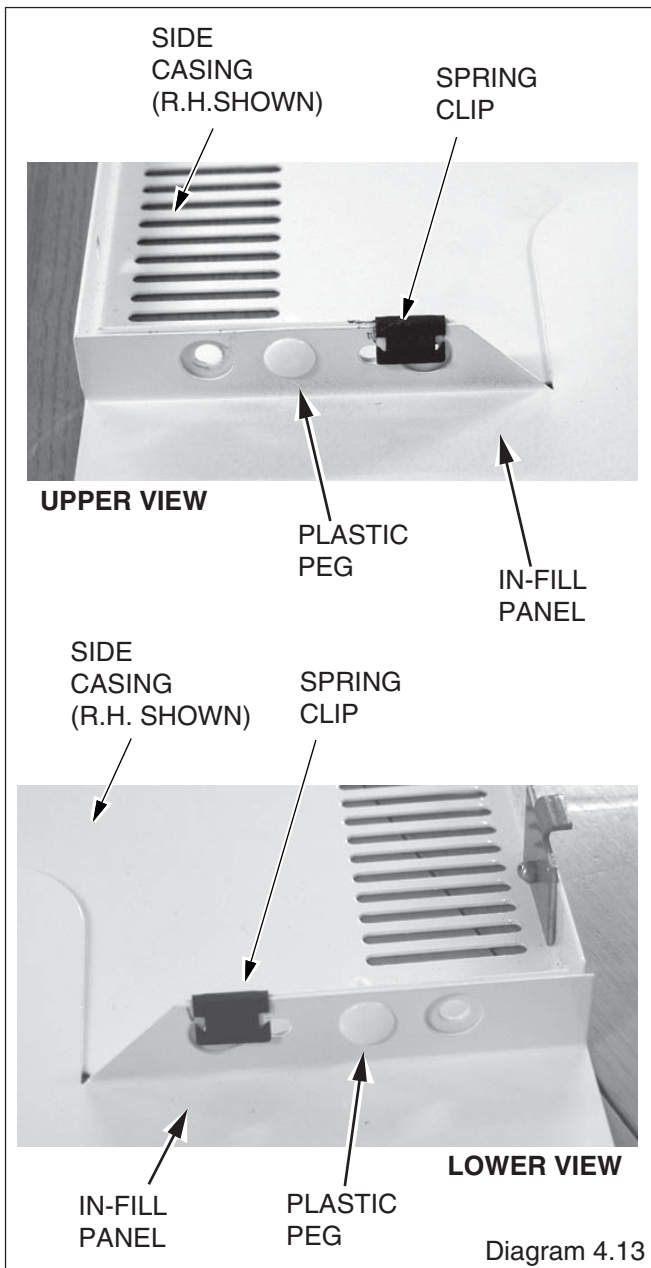

## 4 Installation

### 4.12 Flue / Boiler Connection

Remove the three self-tapping screws from the lower part of the control box support bracket, see diagram 4.16.

Undo the wing nut that secures the top of the heat shield and carefully hinge down control box and heat shield, see diagram 4.16.

Release the two toggle latches that secure the boiler access door and remove, see diagram 4.17.

Remove the electrical connections from the fan by pulling the insulation boots only.

Disconnect the two air pressure tubes from the fan taking note of their positions.

Remove the fan assembly from the flue hood by removing the securing screw, pull forward and lift up to release the 3 hooked securing lugs underneath the fan, see diagram 4.18.

From the flue pack take the flue spigot, the gasket is supplied in the fittings pack.

Connect the flue spigot and gasket to the rear flue outlet of the boiler using the self tapping screws provided, see diagram 4.3.

**IMPORTANT.** With regards to the Manual Handling Operations, 1992 Regulations, the following operation, exceeds the recommended weight for one man lift.

Place the boiler in position taking care not to damage the casing panels.

With access to the flue system through the boiler, pull the flue on to the spigot bayonet connection, twist anti-clockwise to lock into position.

Take the flue duct extension from the boiler and slide on to the fan duct until it will go no further, see diagram 4.19.

Fit fan and engage the flue duct extension into the flue duct, secure fan, replace electrical connections and air pressure tubes.

The polarity of the electrical connections is not important.

Make sure that the air pressure tubes are fitted as before, see diagram 4.20 and that the fan duct engages fully into the flue duct extension piece.

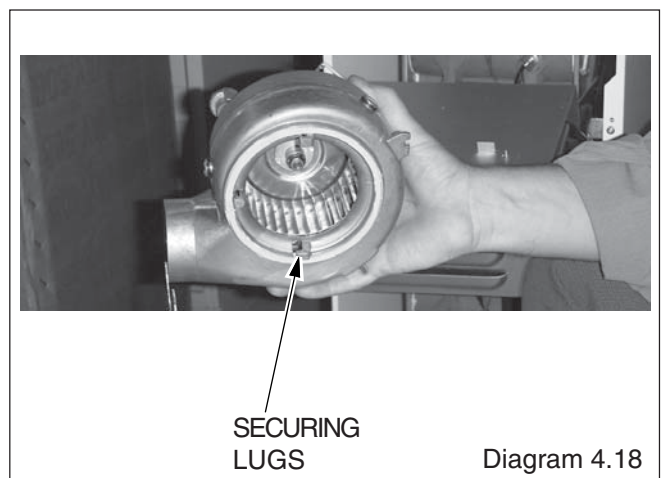
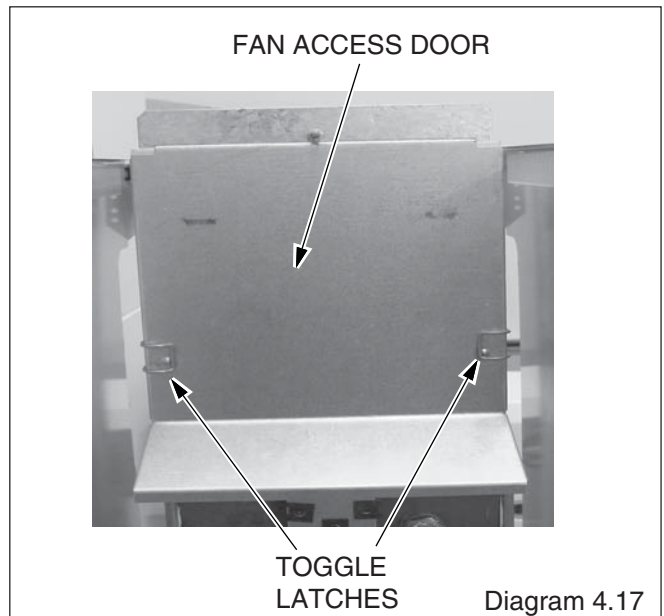
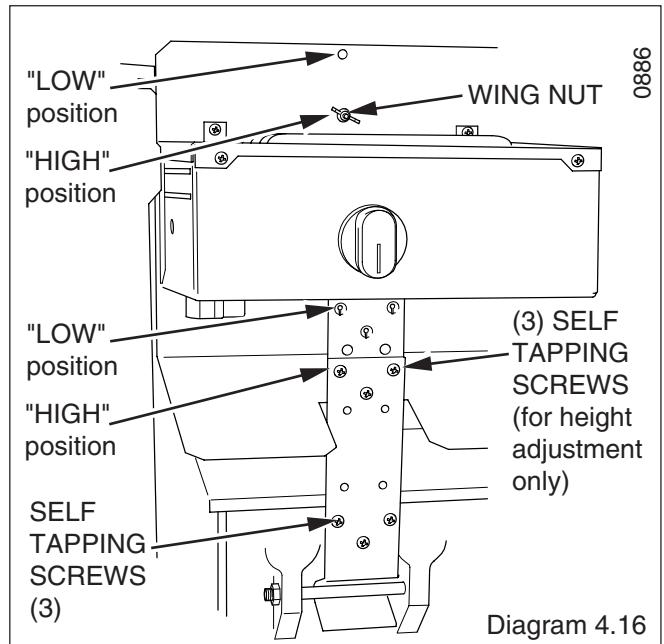

## 4 Installation

### 4.13 Water & Gas connections

Replace fan access door, heat shield and control box.

Note: When replacing the fan access door make sure the lip at the top of door fits into and behind the slotted bracket located at the top of the boiler.

As there are two casing height options, the control box height and the heat shield may have to be adjusted to suit your requirements.

Complete the water connections to the boiler.

Fill, vent and flush the system.

Check for any water leaks and put right.

Make the gas connection to the service cock, at the lower left hand side of the boiler, see diagram 1.1.

The whole of the gas installation, including the meter, should be inspected, tested for soundness and purged in accordance with the current issue of BS6891.

### 4.14 Top Casing

Refer to diagram 4.21.

Fit two plastic pegs, one on each side, in the holes on the top casing. The plastic pegs are a tight fit and are best pushed home with a flat faced tool.

Secure front of top casing with the screws provided.

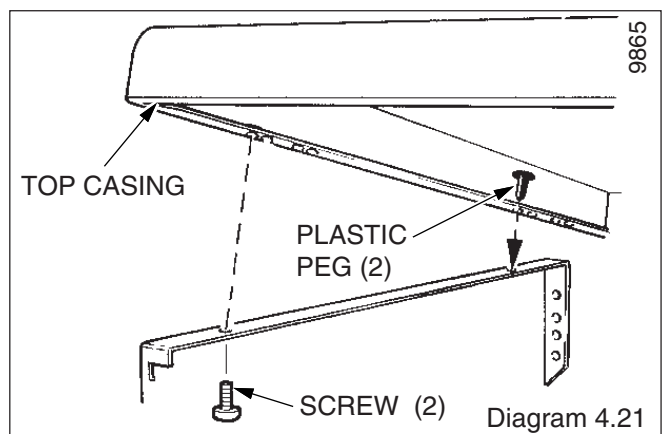
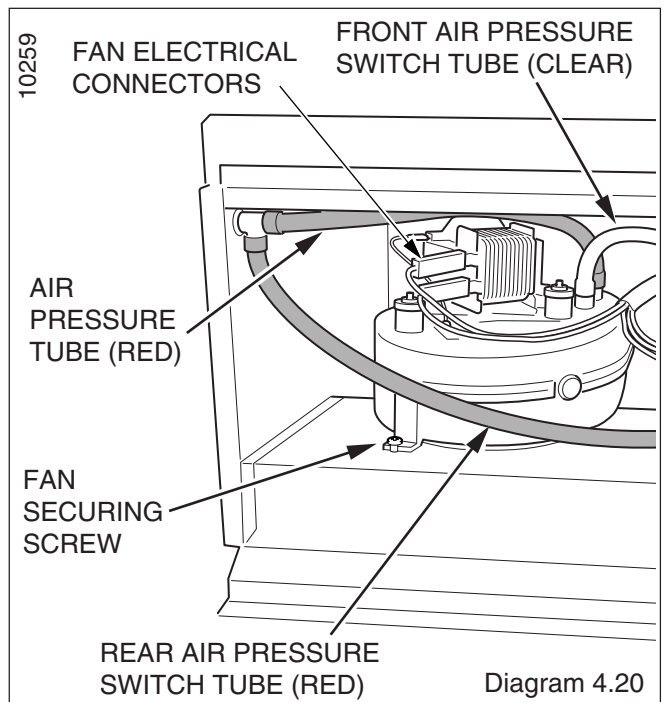
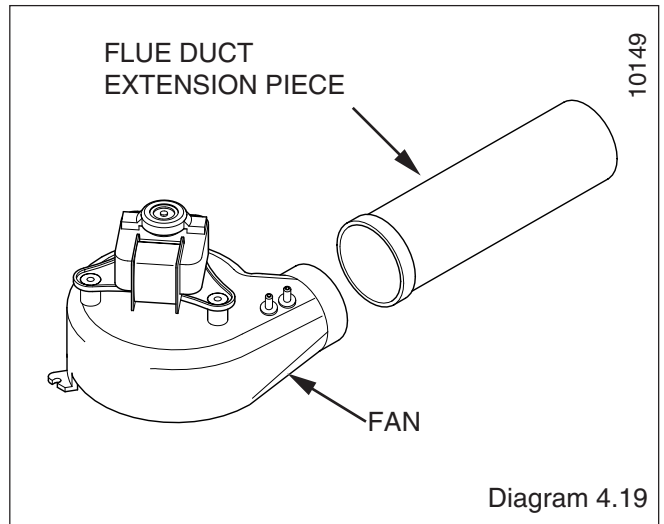

## 5 Electrical Wiring

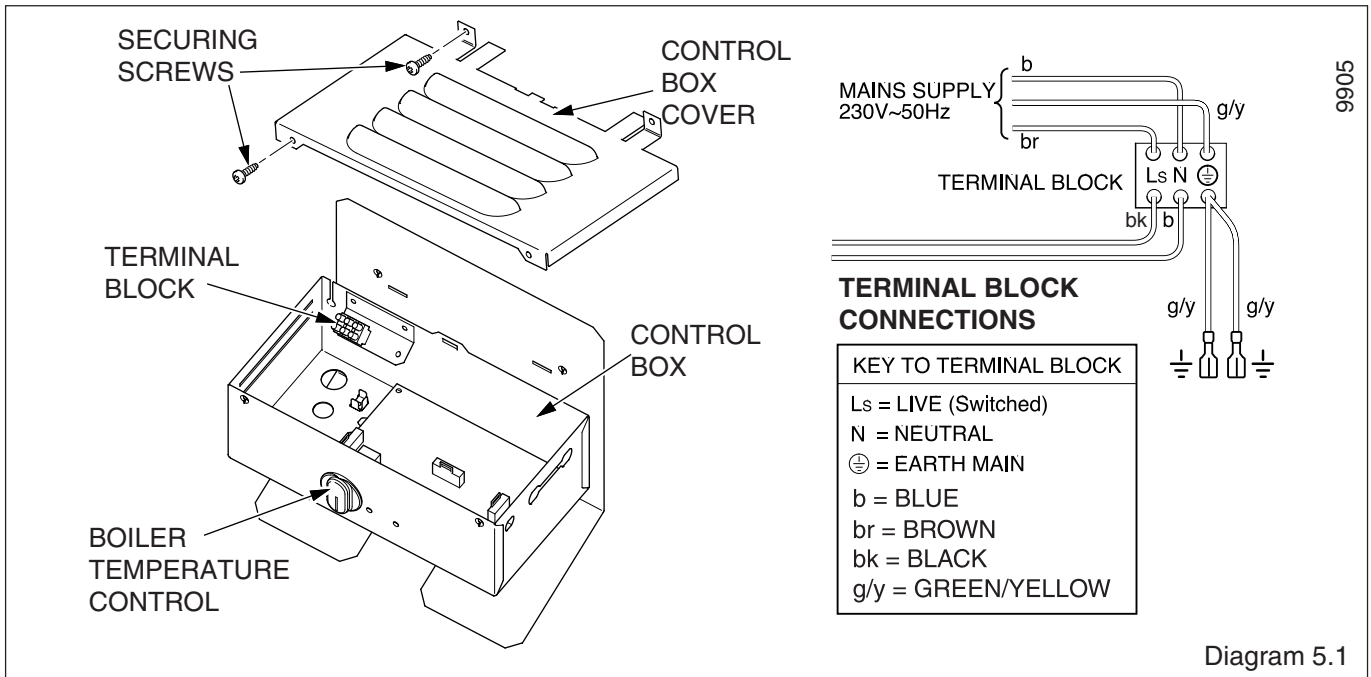

Diagram 5.1

### 5.1 Control Box Access

Remove control box cover by undoing the four securing screws (two on control box, two on the heat shield) and lift off, see diagram 5.1.

### 5.2 Electrical Connections

**WARNING.** This boiler must be earthed.

Take care not to damage any internal wiring.

Using heat resistant (85°C) cable of at least 0.75mm<sup>2</sup> (24/0.2mm) and of a suitable length, route as shown in diagram 5.3. Thread through the grommet at the bottom rear of the control box, through the cable clamp and connect to appropriate terminals. Tighten cable clamp screws, see diagram 5.2.

Standard colours are, brown - live (L), blue - neutral (N) and green/yellow - earth (⊕).

The mains cable outer insulation must not be cut back external to the cable clamp.

Make sure the cable is suitably secured.

When making connections make sure that the earth conductor is made of a greater length than the current carrying conductors, so that if the cable is strained the earth conductor would be the last to become disconnected.

### 5.3 Pump Connection

The pump must be connected to the external controls.

### 5.4 Testing - Electrical

Checks to ensure electrical safety must be carried out by a competent person.

After installation of the system, preliminary electrical system checks as below should be carried out.

1. Test insulation resistance to earth.
2. Test earth continuity and short circuit of all cables.
3. Test the polarity of the mains.

The installer is requested to advise and give guidance to the user of the controls scheme used with the boiler.

Replace the control box cover.

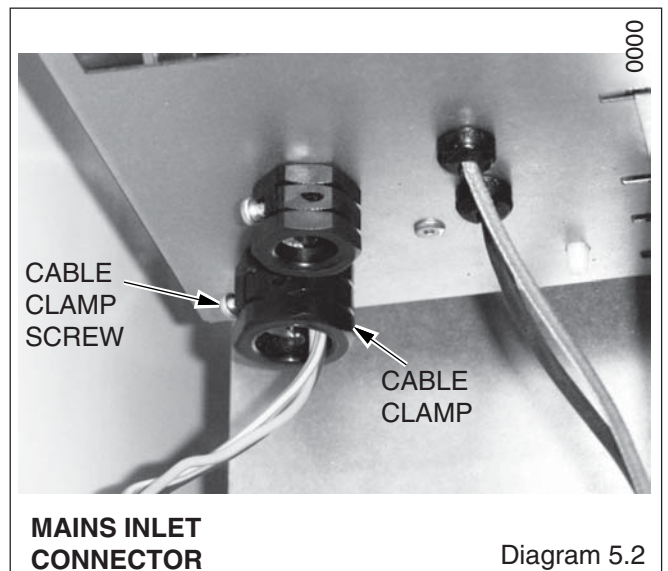

Diagram 5.2

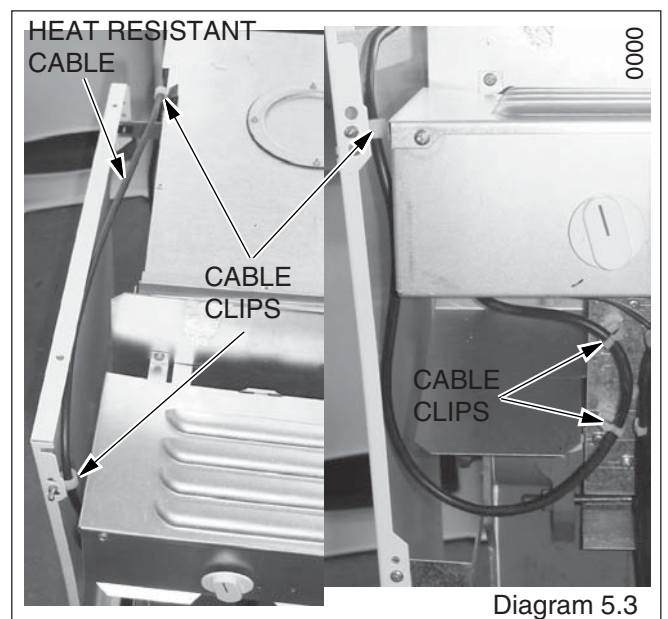

Diagram 5.3

## 6 Commissioning

### IMPORTANT NOTE

The WARNING NOTICE attached to the front casing *must only* be removed by the user

Please ensure the "Benchmark" logbook is completed and left with the user, and the magnetic lighting instruction label is placed on the surface of the boiler casing.

### 6.1 All Systems

Commissioning should be carried out by a competent person in accordance with the current issue of BS6798.

UNDER ALL CIRCUMSTANCES the case must be correctly fitted and sealed, unless fault finding.

Make sure that the system has been thoroughly flushed out with cold water without the pump in place.

Refit the pump, fill the system with water, ensuring that all the air is properly vented from the system and pump.

### 6.2 Initial Lighting and Testing

**CAUTION.** This work must be carried out by a competent person, in accordance with the current issue of BS6798.

Make sure that all naked lights and cigarettes are extinguished.

Refer to 'Instructions for Use' and identify the controls.

Check that the boiler is isolated from the electrical supply.

Turn the gas service cock "On", see diagram 6.1.

Purge in accordance with the current issue of BS6891.

**WARNING.** The multifunctional control and fan operate on mains voltage, terminals will become live.

If programmer control is fitted, make sure it is in the ON mode.

Make sure that any remote controls are calling for heat.

Turn the boiler temperature control clockwise to "Max".

The ignition system will operate to light the boiler. After a pre-set time if ignition has not taken place the boiler will shutdown.

To re-start the lighting sequence, turn the boiler temperature control to "O", then fully clockwise to "Max".

"Max" is approximately 82°C (180°F).

After the burner has lit, the "Burner on" neon on the control panel will come on.

Isolate the boiler from the electrical supply.

Loosen the burner pressure test point screw and connect a suitable pressure gauge, see diagram 6.1.

Switch on the electrical supply to the boiler.

**WARNING.** The multifunctional control and fan operate on mains voltage, terminals will become live.

### 6.3 Testing - Electrical

Turn the boiler temperature control fully clockwise to the maximum setting.

The lighting sequence is automatic as follows:

The fan operates and after a short period of time, the spark ignition operates, the solenoid opens, then the burner will light shown by the "Burner On" neon on the control panel lighting up.

The burner will remain alight until switched off, either by the boiler temperature control, programmer (if fitted) or any remote system control.

To make sure that the flame supervision device is working correctly the following should be done.

With the burner alight, turn the gas service cock "Off", see diagram 6.1.

After a short period the burner will go out.

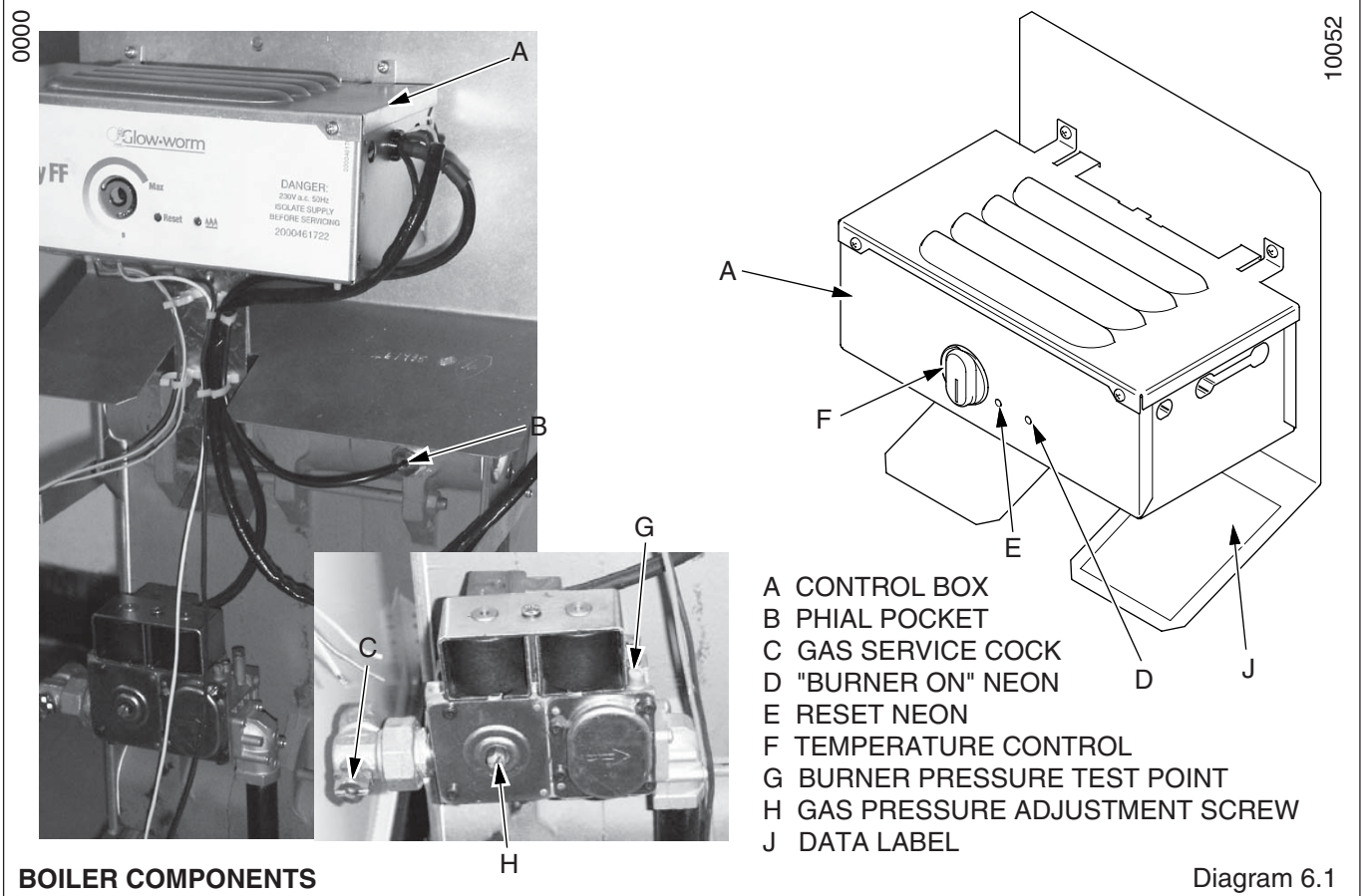

## 6 Commissioning

The correct working of the flame supervision is shown by the "Burner On" neon going out and the ignition sequence starting up.

After a short period the boiler will shut down.

If the lighting sequence described fails, refer to fault finding section 9.

To carry on turn the gas service cock "On", see diagram 6.1.

To re-start the lighting sequence, turn the burner temperature control to "0" then fully clockwise to "Max."

During normal operation when the boiler switches "Off", the burner will go out. The automatic lighting sequence will work again when heat is required.

If the reset neon lights, turn the boiler temperature control to "0" (off), wait 30 seconds, then repeat the lighting instructions.

### 6.4 Testing - Gas

With the boiler on proceed as follows:

Test for gas soundness around the boiler gas components using a suitable leak detection fluid, in accordance with the current issue of BS6891.

Check the burner gas pressure at least 10 minutes after boiler has lit, refer to Data Label, see diagram 1.2.

If necessary adjust the gas pressure to obtain the required setting turning screw clockwise, to decrease pressure, see diagram 6.1.

Should any doubt exist about the gas rate, check it using the gas meter test dial and stop watch at least 10 minutes after the burner has lit, making sure that all other gas burning appliances and pilot lights are off.

Gas rate: **Hideaway 80B FF** : 2.8m<sup>3</sup>/h (79ft<sup>3</sup>/h)

is for guidance only, dependent on the heat setting.

Turn the boiler temperature control fully anti-clockwise to "0".

Isolate from the electrical supply.

Remove the pressure gauge from the test point and refit screw, making sure a gas tight seal is made.

When the boiler temperature control is turned to the "0" position, by hand, wait at least 30 seconds before turning On again.

There may be an initial smell given off from the boiler when new, this is quite normal and it will disappear after a short period of time.

### 6.5 Testing - All Water Systems

Allow the system to reach maximum working temperature and examine for water leaks.

There should be no undue noise in the system.

The boiler should then be turned off and the system drained off as rapidly as possible, whilst still hot.

Refill system.

### 6.6 Open Vented System

Ensure there is no pumping over of water or entry of air at the open vent above the feed and expansion cistern.

### 6.7 Adjustment - Fully Pumped Open Vented System

When commissioning the system the boiler should first be fired on full service, that is, central heating and domestic hot water. Adjust the pump to the system design setting, then balance the system, making adjustments as necessary.

### 6.8 Completion

Adjust the boiler temperature control and any system controls to their required settings.

Fit the bottom plinth panel and secure with two dog point screws, see diagram 6.2.

Finally fit the front panel by hooking under front of top panel locating on the two studs, see diagram 6.2 and securing at the bottom on to the bottom plinth panel with two screws, see diagram 6.3.

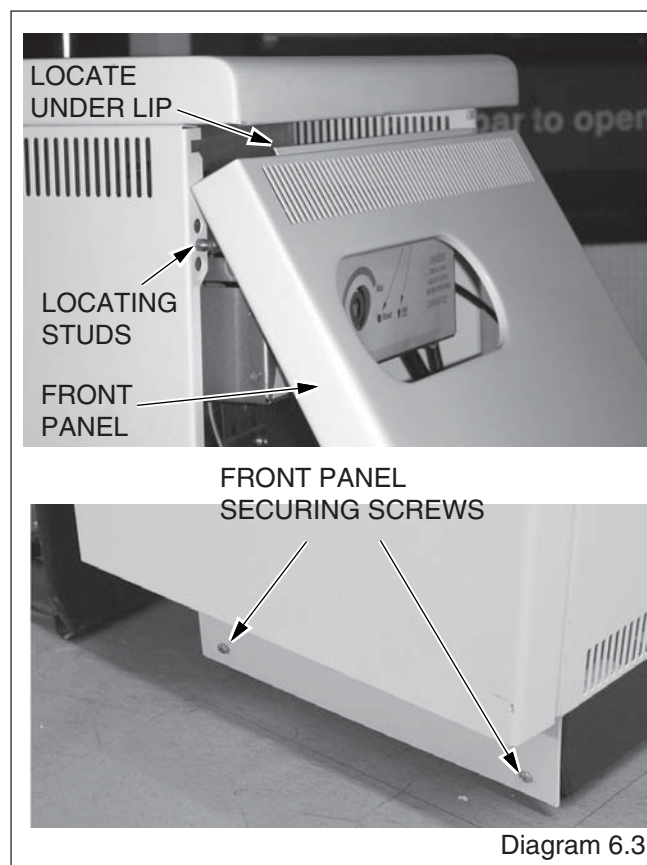
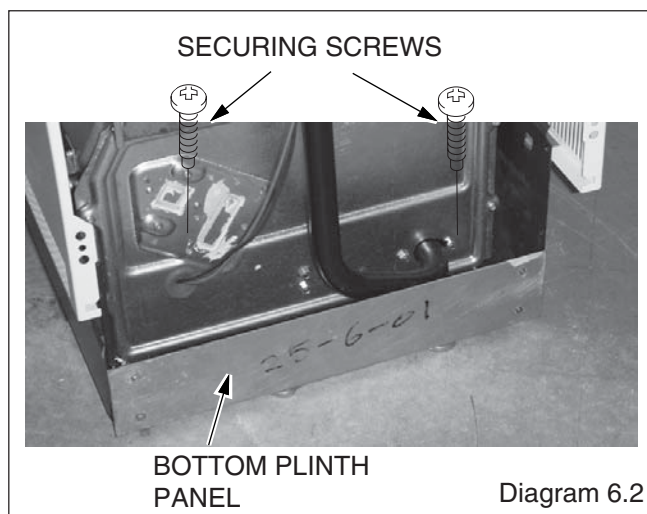

## 7 Instructions to the User

Instruct and demonstrate the safe and efficient operation of the boiler, heating system and domestic hot water system.

Advise the user, that to ensure the continued efficient and safe operation of the boiler, it is recommended that it is checked and serviced at regular intervals. The frequency of servicing will depend upon the particular installation and usage, but in general once a year should be enough.

Draw attention, if applicable to the current issue of the Gas Safety (Installation and Use) Regulations, Section 35, which imposes a duty of care on all persons who let out any property containing a gas appliance.

It is the Law that servicing is carried out by a competent person.

Advise the user of the precautions necessary to prevent damage to the system and building in the event of the heating system being out of use during frost and freezing conditions.

Reminder - Leave these instructions and the "Benchmark" logbook with the user.

## 8 Servicing

**REMEMBER,** When replacing a part on this appliance, use only spare parts that you can be assured conform to the safety and performance specification that we require. Do not use reconditioned or copy parts that have not been clearly authorised by Hepworth Heating Ltd.

### Products of Combustion Check

Note: To obtain a products of combustion reading, remove the front panel and remove the control box as described in the relevant paragraphs of section 4.12. Next, remove the cap from the sampling point, located on the top of the left hand side of the inner casing, see diagram 8.1.

Connect the analyser tube on to the nipple.

**WARNING.** The multifunctional control and fan operate on mains voltage, terminals will become live.

Switch on the electrical supply and gas supply then operate the boiler.

On completion of the test switch off the electrical supply and gas supply, remove analyser tube and replace sampling point cap.

### Servicing

Before servicing turn off the gas and isolate the electrical supply to the boiler.

After completing a service always test for gas soundness, make electrical checks and carry out functional check on controls.

Unless stated otherwise all parts are replaced in the reverse order to removal.

### 8.1 Access

Remove the boiler front casing panel, refer to paragraph 6.8.

Remove the bottom plinth panel by unscrewing the two dog point screws securing the panel to the boiler plinth, see diagram 8.4.

Disconnect gas valve from gas cock and unplug electrical plug from gas valve, firstly removing electrical plug securing screw, see diagram 8.2.

Unclip electrical wires from control box support bracket, see diagram 8.3.

Undo the four self-tapping screws that secure the combustion chamber front and carefully withdraw it together with the burner and gas valve assembly, taking care not to strain the ignition and earth wire, see diagram 8.5.

Note: When replacing burner in combustion chamber make sure it fits correctly on the guides.

Disconnect the ignition and earth leads from the burner and remove by drawing the leads through the grommet, see diagram 8.5.

Remove the three self-tapping screws from the lower part of the control box support bracket, see diagram 8.6.

Undo the wing nut that secures the top of the heat shield and carefully hinge down control box and heat shield, see diagram 8.6.

Release the two toggle latches that secure the boiler access door and remove, see diagram 8.7.

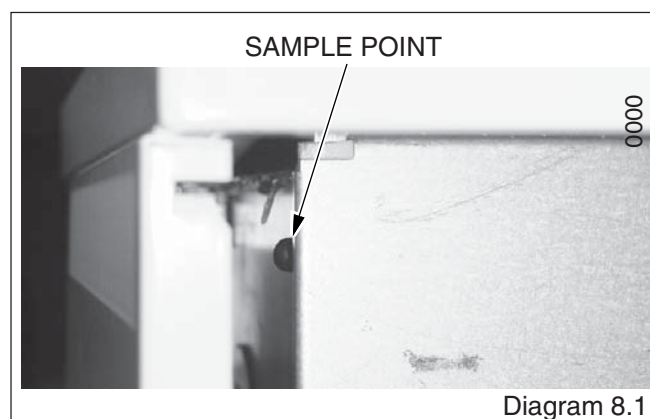

Diagram 8.1

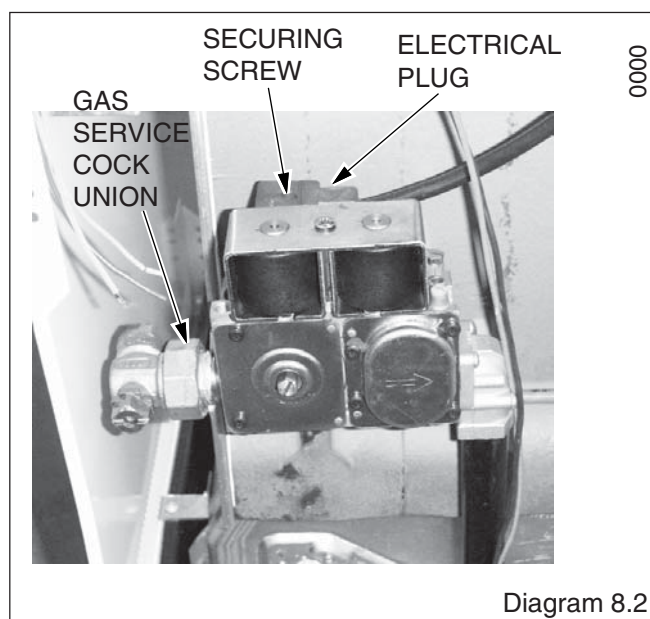

Diagram 8.2

## 8 Servicing

Note: When replacing the fan access door make sure the lip at the top of door fits into and behind the slotted bracket located at the top of the boiler.

Note: To ease removal of the right hand baffle from the heat exchanger, remove both silicone tubes from the air pressure switch.

Remove fan securing screw, electrical connections and air pressure tubes, then remove fan by sliding back to disengage the retaining lugs then lift up, see diagram 8.7.

Remove the flue hood.

When replacing the flue hood ensure that it rests on the guides and that the rear of flue hood is located under the pegs at the rear and pushed down and back fully.

**IMPORTANT:** When re-fitting fan check that it fits fully into the flue duct extension piece.

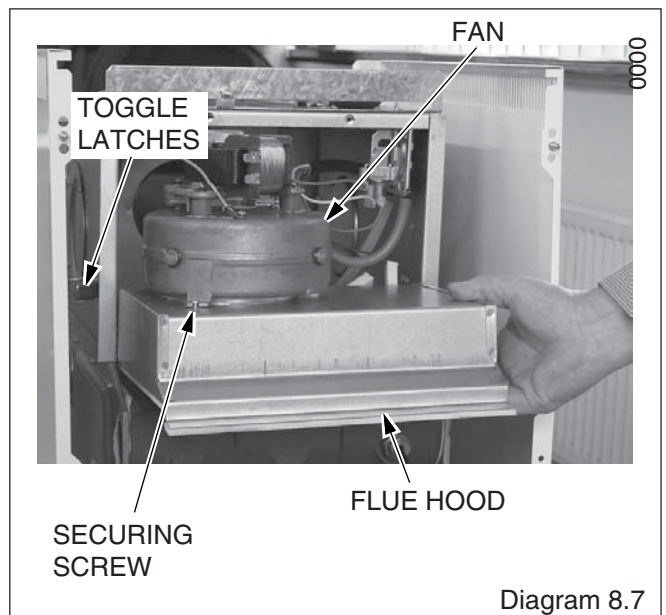
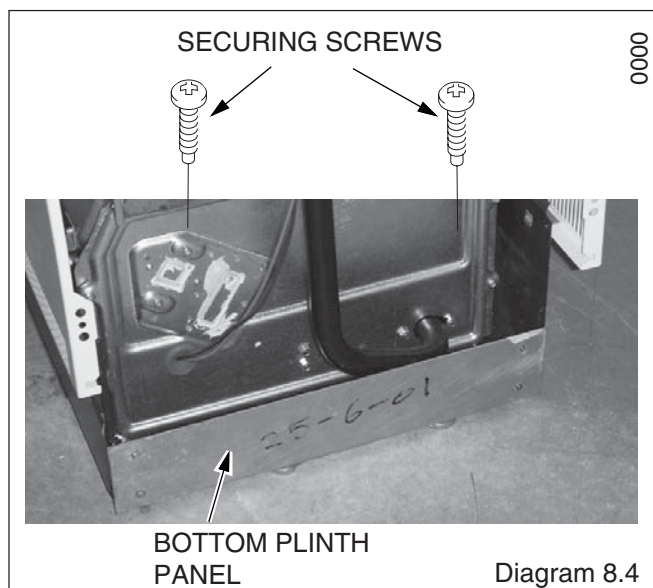
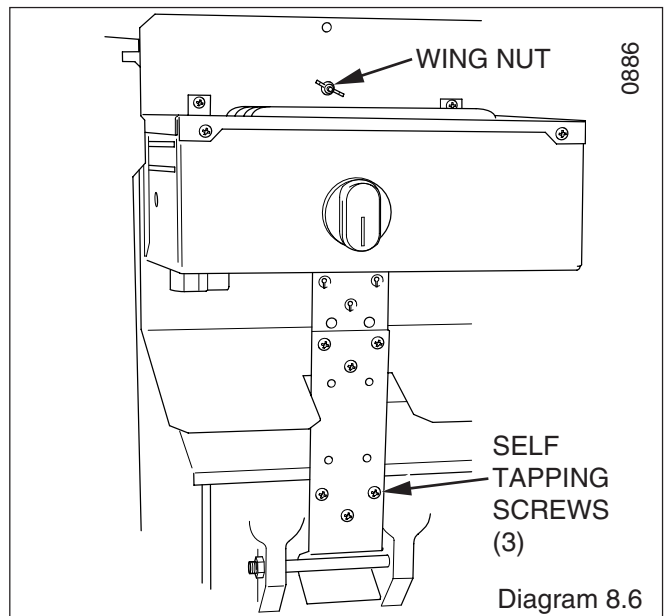
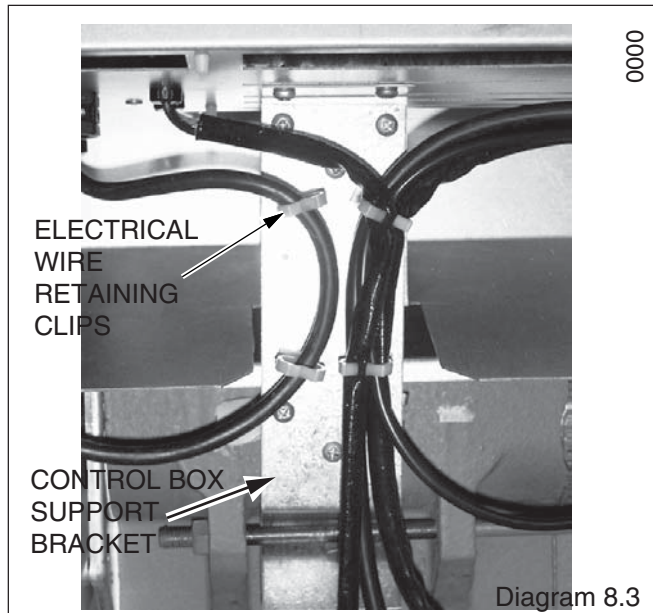
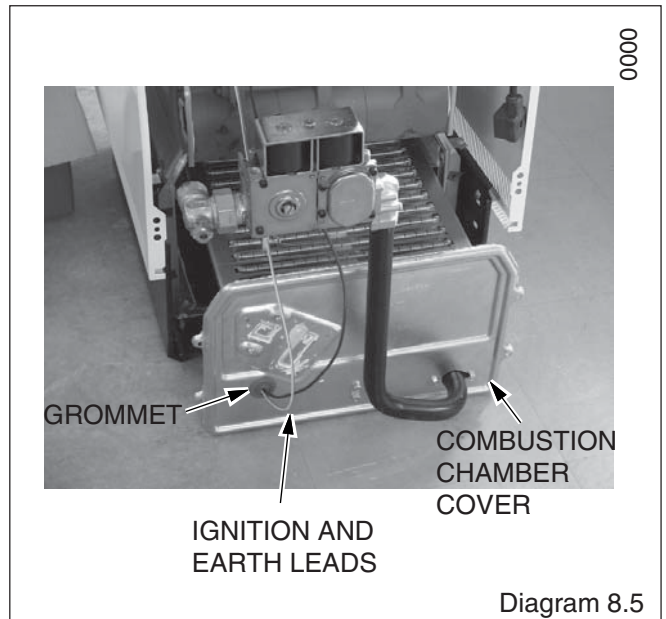

## 8 Servicing

### 8.2 Boiler Flueways

Remove flueway baffles noting that there are 2 centre and 2 side flueway baffles, see diagram 8.8.

Place a sheet of paper in the combustion chamber to catch any flue debris.

Thoroughly clean boiler flueways and fins with a suitable stiff brush.

Replace in reverse order, after completing the relevant instructions in sections 8.3 and 8.4.

### 8.3 Burner and Injector

Remove the two screws and nuts securing the burner support bracket to the combustion chamber cover, see diagram 8.9.

Remove the graphite coated nuts on the supply feed pipe at the rear of the burner to release the burner, see diagram 8.10.

Clean the burner. Use a vacuum cleaner or suitable stiff brush (not wire) to clean the burner thoroughly, making sure that all the burner ports are clear and unobstructed.

Check the burner injector for blockage or damage and replace if necessary, see diagram 8.11.

With the burner removed the injector can be inspected and cleaned as necessary.

For cleaning do not use a wire or sharp instrument on the hole.

If removed, use a little suitable sealant on the external thread when refitting to make sure a gas tight seal is made.

### 8.4 Service Checks

Inspect the spark electrode and clean and replace as necessary, see diagram 8.12.

Check the condition of the side and rear insulation panels in the combustion chamber.

Check the condition of the seals on the boiler access door and the combustion chamber cover.

Examine the flue hood and terminal to make sure they are clean and clear of obstructions.

Refit all parts.

Light the boiler and carry out functional tests as described in section 6.

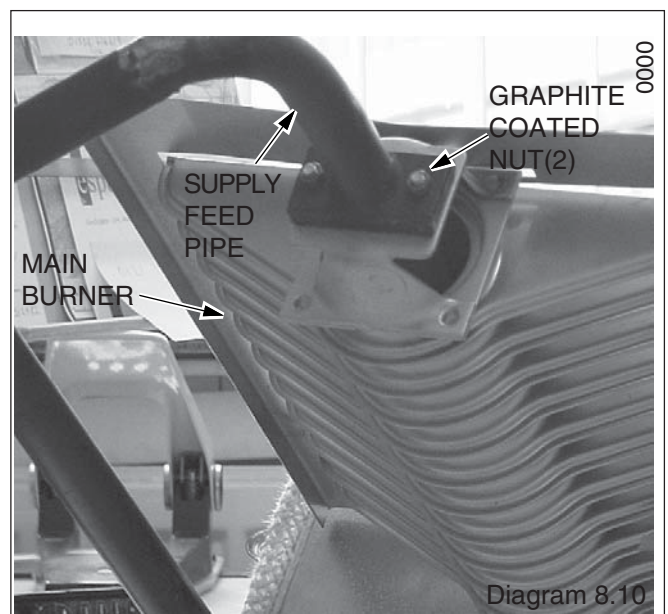
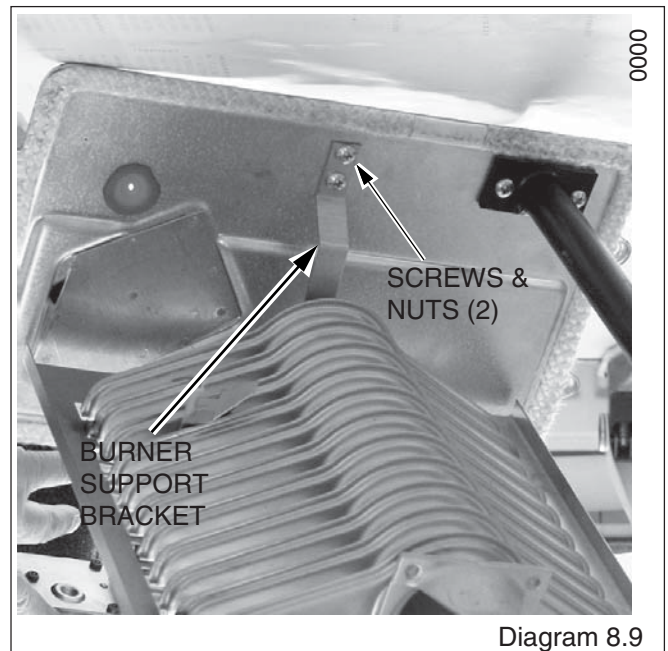
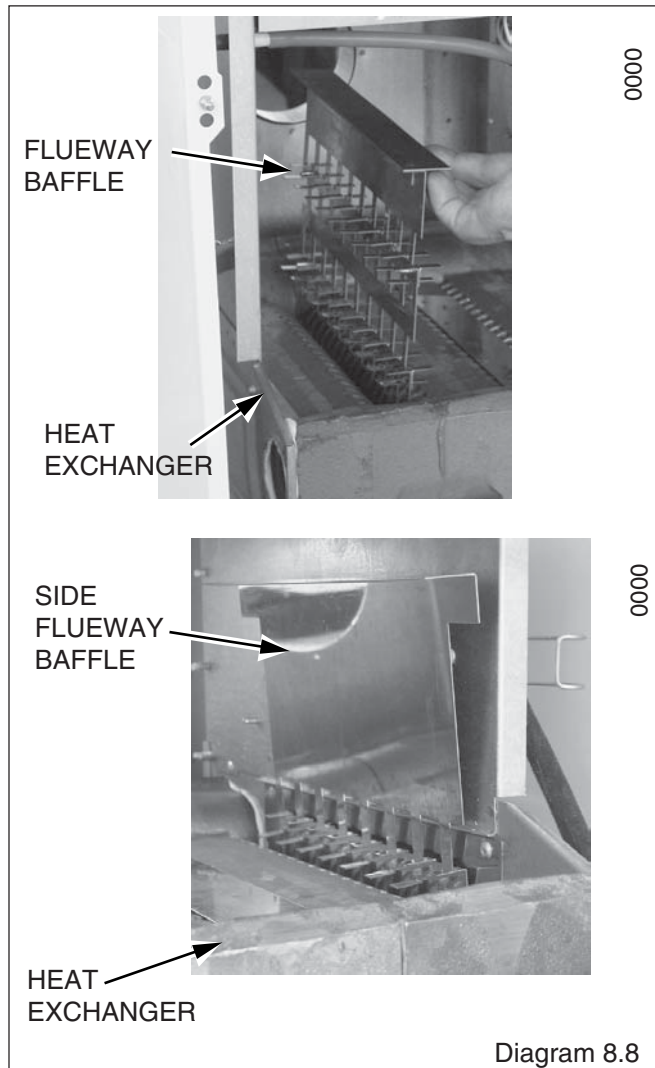

## 8 Servicing

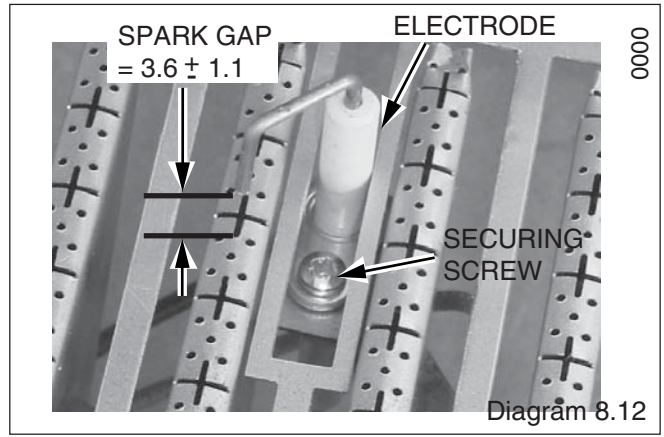
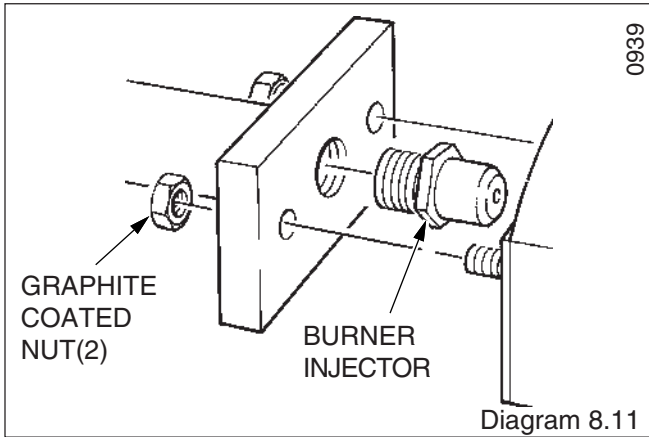

## 9 Fault Finding

**IMPORTANT.** On completion of the Fault Finding task which has required the breaking and remaking of the electrical connections, the continuity, polarity, short circuit and resistance to earth checks must be repeated using a suitable multimeter.

**WARNING.** The multifunctional control and fan operate on mains voltage, the terminal will be live.

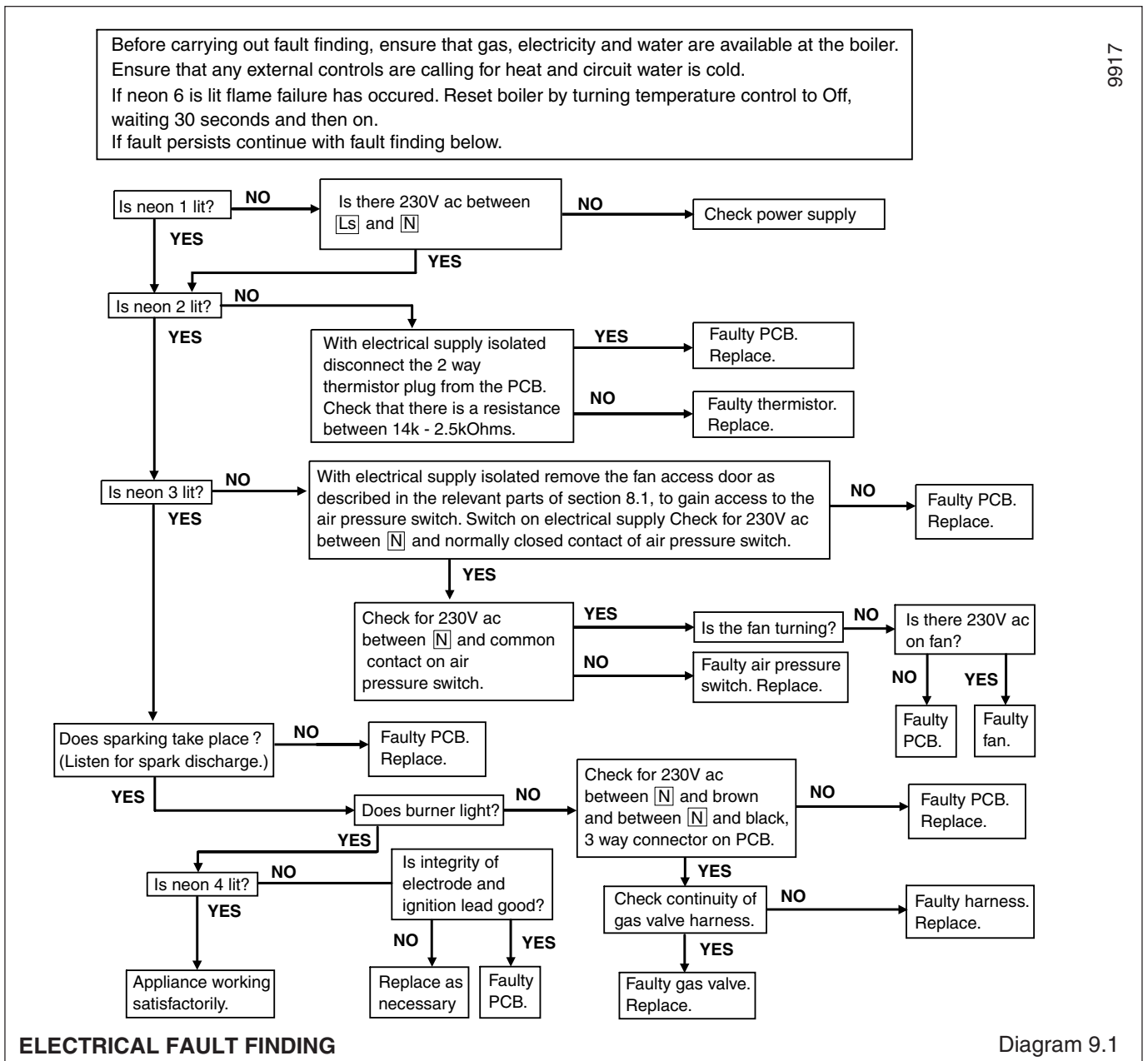

# 9 Fault Finding

## 9.1 Electrical

Gain access to the control box, refer to the relevant paragraph in section 6.1, then remove the control box cover, refer to section 5.1.

Refer to: Boiler Fault Finding, see diagram 9.1, Fault Finding Wiring Diagram, see diagram 9.3, Pictorial Wiring Diagram, see diagram 9.4.

## 9.2 Electrical Supply Failure

Failure of the electrical supply will cause the burner to go out. Operation will normally resume on the restoration of the electrical supply.

If the burner does not relight after an electrical supply failure and the red neon on the control panel is lit, turn the burner temperature control to "0", wait 30 seconds, then fully clockwise to "Max." see diagram 9.2.

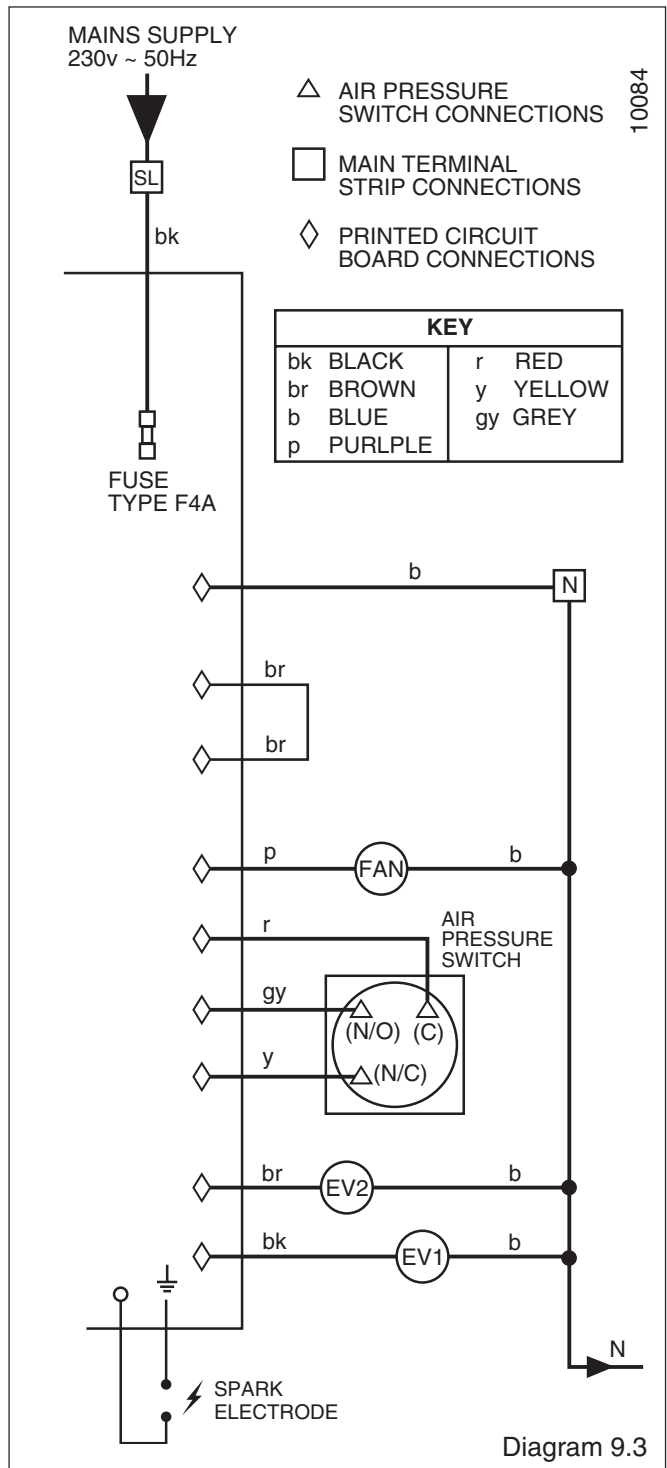
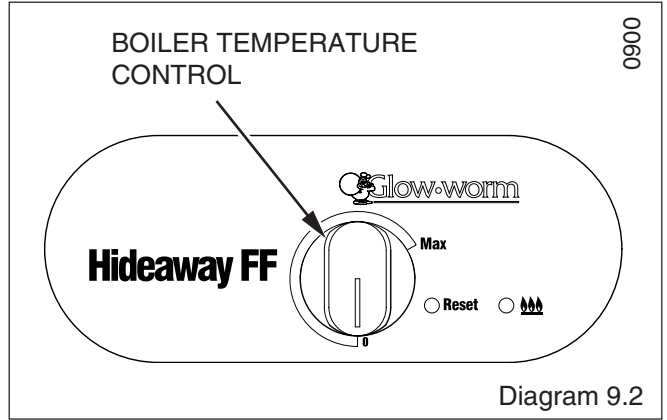

# 9 Fault Finding

10176

NEON KEY (see P.C.B)		
NEON 1 =		= MAINS ON
NEON 2 =		= DEMAND ON
NEON 3 =		= FAN RUNNING
NEON 4 =		= BURNER LIT
NEON 5 =		= SAFETY TEMPERATURE LIMITER
NEON 6 =		= FLAME FAILURE

KEY	
br	BROWN
b	BLUE
g/y	GREEN/YELLOW
g	GREY
bk	BLACK
p	PURPLE
y	YELLOW
r	RED

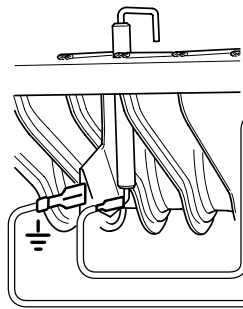

P.C.B (CONTROL BOARD)

F4A FUSE

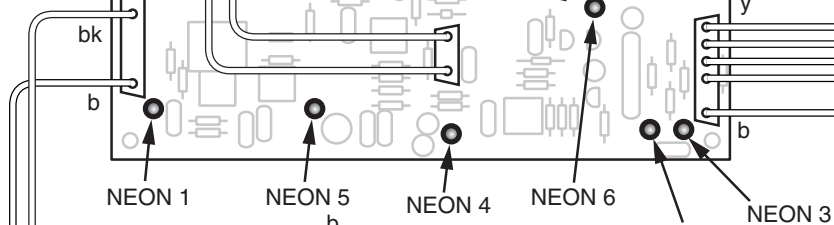

MAINS SUPPLY 230V~50Hz

TERMINAL BLOCK

KEY TO TERMINAL BLOCK	
Ls	= LIVE (Switched)
N	= NEUTRAL
⊕	= EARTH MAIN

BOILER PILOT FAULT FINDING

Diagram 9.4

## 10 Replacement of Parts

### IMPORTANT NOTES

REMEMBER, When replacing a part on this appliance, use only spare parts that you can be assured conform to the safety and performance specification that we require. Do not use reconditioned or copy parts that have not been clearly authorised by Hepworth Heating Ltd.

Replacement of parts must only be carried out by a competent person.

Before removing or replacing any parts, turn off the gas supply at the gas service cock, see diagram 8.2 and isolate the electrical supply to the appliance.

Unless stated otherwise, all parts are replaced in the reverse order to removal.

After replacing any parts always test for gas soundness and if necessary carry out functional check of controls.

### 10.1 Electrical Thermistor

Remove front panel to gain access, see section 6.8.

Remove control box cover by undoing the four securing screws (two on control box, two on the heat shield) and lift off, see diagram 10.1.

Remove thermistor lead from retaining clip, located on the control box support bracket, see diagram 8.3.

Release strain relief grommet securing thermistor lead at the side of control box.

Disconnect the thermistor electrical plug from the control board (P.C.B) slightly bending back the retaining latch to allow withdrawal, see diagram 10.2.

Remove the retaining wire and withdraw the electrical thermistor from its phial, see diagram 10.3.

Draw the thermistor lead followed by the thermistor out through the control box case.

Re-assembly note. When fitting the thermistor make sure it is fully inserted into the phial, see diagram 10.3. Take care when re-threading retaining wire so as not to damage thermistor.

### 10.2 Control Board (P.C.B)

Remove front panel to gain access, see section 6.8.

Remove control box lid by undoing the four securing screws (two on control box, two on the heat shield) and lift off, see diagram 10.1.

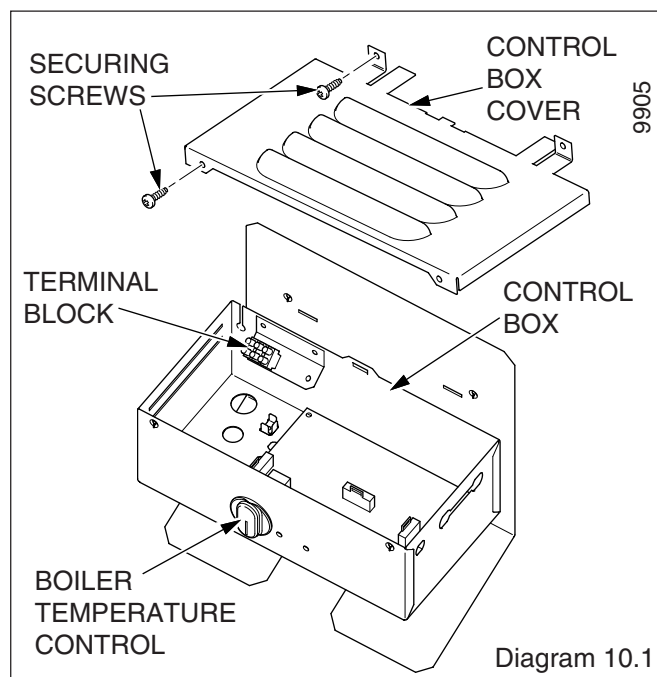

Diagram 10.1

Carefully pull the boiler temperature control knob away from the P.C.B.

Disconnect the electrical plugs from the control board (PCB) slightly bending back the retaining latches to allow withdrawal, see diagram 10.2.

Disconnect ignition lead.

Carefully pull the board away from its supports bending back slightly the retaining latches.

When refitting refer to wiring diagram 9.4.

Take care when replacing the burner temperature control knob by supporting the potentiometer on the P.C.B.

### 10.3 Electrode

Refer to the relevant paragraphs of the servicing section to remove the burner from combustion chamber.

To remove the electrode, unscrew from the retaining bracket, see diagram 8.12.

Take the electrode out from below and remove the ignition lead.

When removing and replacing the electrode take care not to damage it.

When refitting, check spark gap, see diagram 8.12.

### 10.4 Multifunctional Control

Remove front panel to gain access, see section 6.8.

Remove the securing screw and disconnect the electrical plug, see diagram 10.4.

Disconnect the gas cock, on the left hand side.

Support the multifunctional control, remove the four screws (2 long, 2 short) from the flanged connection at the right hand side.

Remove and discard the original "O" ring from the flanged connection and fit the new "O" ring supplied, into recess, before fitting the replacement multifunctional control.

After assembly test for gas soundness and purge in accordance with the current issue of BS6891.

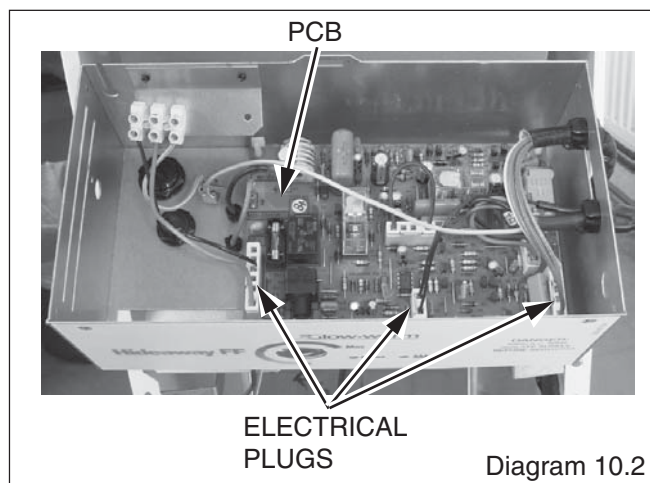

Diagram 10.2

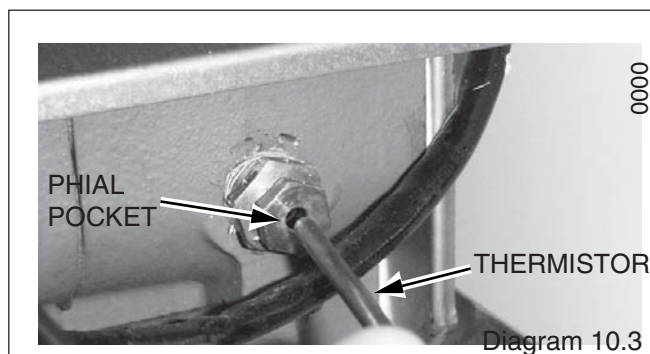

Diagram 10.3

## 10 Replacement of Parts

### 10.5 Solenoid

Remove the electrical plug from the multifunctional control and remove the securing screw and then the solenoid assembly, see diagram 10.4.

### 10.6 Burner

Refer to the relevant paragraphs of the servicing section to remove the burner from combustion chamber.

### 10.7 Injector

Refer to the relevant paragraphs of the servicing section to remove the burner from combustion chamber.

The injector can then be unscrewed from the manifold.

When replacing use a little jointing compound on the external thread only, to ensure a gas tight seal.

### 10.8 Air Pressure Switch

Remove front panel to gain access, see section 6.8.

Refer to the relevant paragraphs of the servicing section to remove the burner from combustion chamber.

Remove the air pressure tubes and electrical connections from the switch, release the securing screws and remove the switch, see diagram 10.5.

When fitting the replacement make sure that the air pressure tubes are fitted with the clear tube from the air pressure switch to the front fan connection, as shown in diagram 10.5 and the electrical connections are made as shown in wiring diagram 9.4.

### 10.9 Fan

Remove front panel to gain access, see section 6.8.

Refer to the relevant paragraphs of the servicing section to remove the burner from combustion chamber.

Remove the electrical connections and air pressure tubes from the fan.

**Note:** Remove the electrical connections by pulling insulation boots only.

Undo the screw securing the fan to the flue hood and disengage fan from flue hood.

When re-assembling, make sure that the air pressure tubes are fitted as before and that the fan duct engages fully into the flue duct extension piece.

The polarity of the electrical connections is not important.

### 10.10 Insulation

Refer to the relevant paragraphs of the servicing section to remove the burner from combustion chamber.

#### Sides

Undo the burner support bracket nuts and remove support bracket and insulation, see diagram 10.6.

Refit support bracket with new side insulation.

#### Rear

Bend forward rear insulation securing nibs, one on each side, to release insulation.

Fit new insulation and bend back securing nibs.

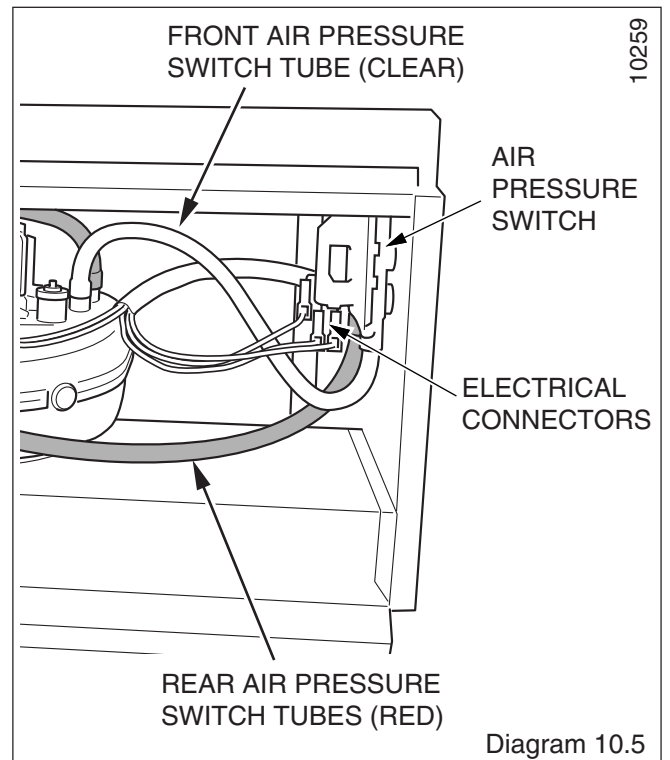

Diagram 10.5

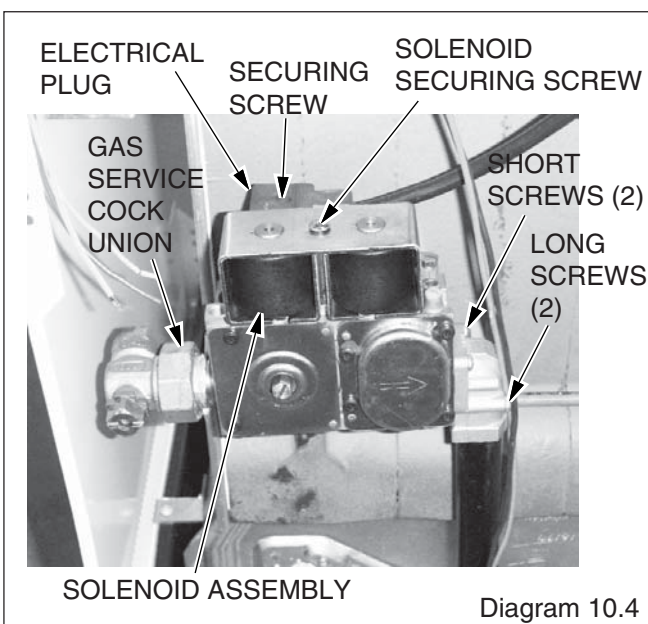

Diagram 10.4

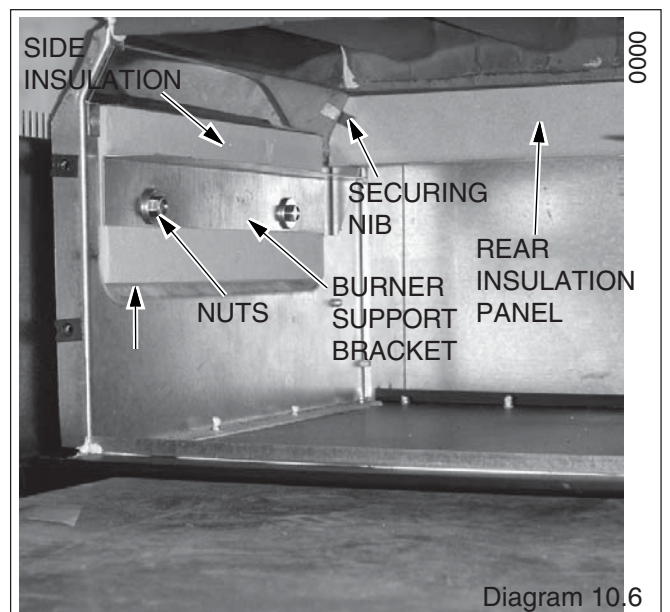

Diagram 10.6

# 11 Spare Parts

## 11.1 Part Identification

The key number in diagram 11.1 and the first column of the list will help identify the spare part.

## 11.2 Ordering

When ordering any spare part please quote the part number and the description from the list together with the model name and serial number information from the data label.

The data label is positioned on the heat shield, see diagram 6.1.

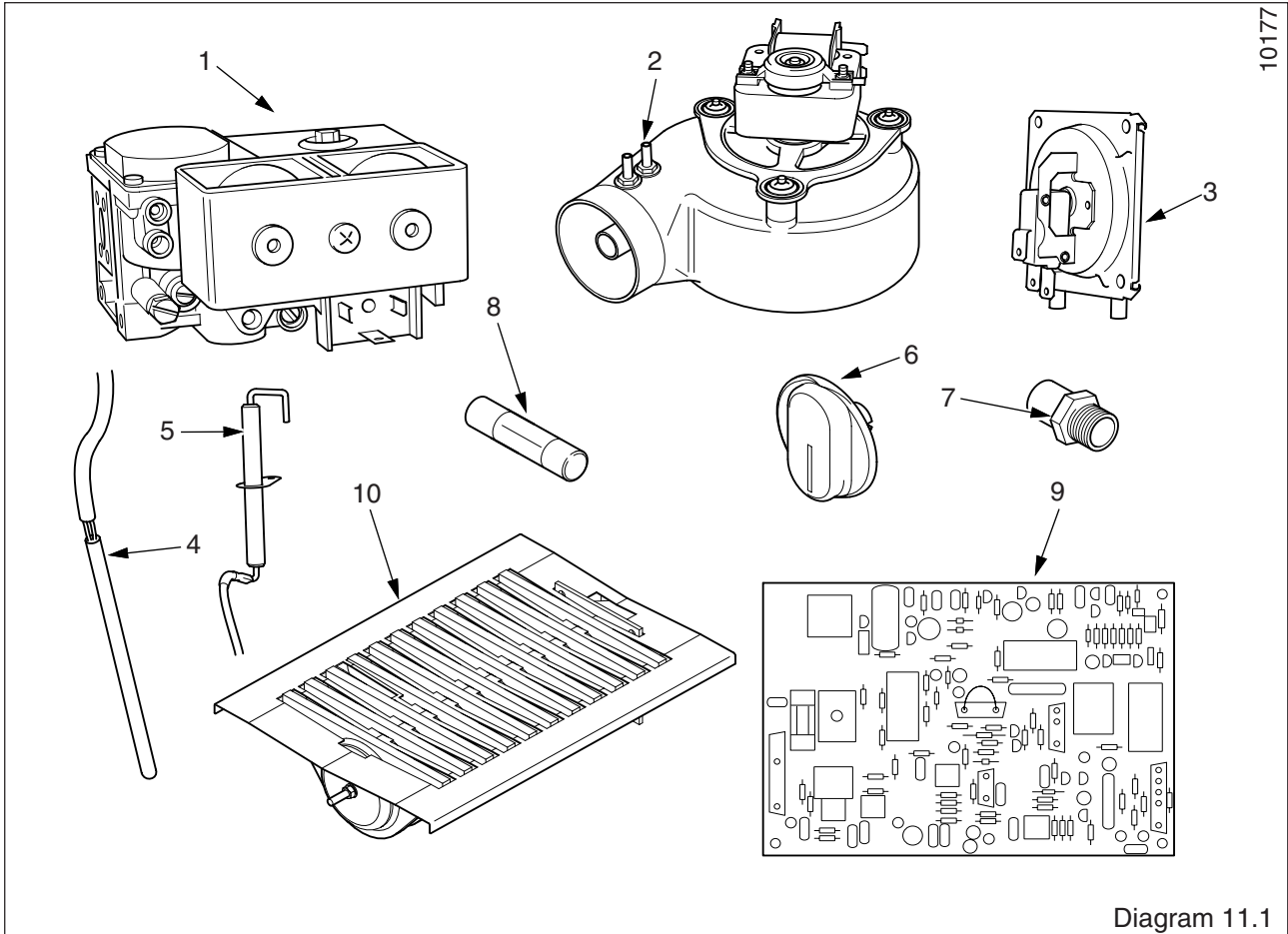

Diagram 11.1

Key No.	Part No.	Description	GC Part No.
1	2000461752	Multifunctional control	*****
2	227132	Fan	*****
3	2000461994	Air pressure switch	*****
4	2000461985	Electrical thermistor	*****
5	202635	Spark electrode	*****
6	2000461714	Boiler temperature control knob	*****
7	2000461924	Injector	*****
8	227098	Fuse	*****
9	227030	Control board	*****
10	205656	Burner	*****

*Because of our constant endeavour for improvement, details may vary slightly from those shown in these instructions.*