

Glow worm

Instructions for Use Installation and Servicing

To be left with the user

Hideaway 80B

G.C. No. 41 313 24

Balanced Flue Boiler



BS 6332
BS 5258

This is a Cat I_{2H} Appliance

Reference in these instructions to British Standards and Statutory Regulations/Requirements apply only to the United Kingdom. For Ireland the rules in force must be used.

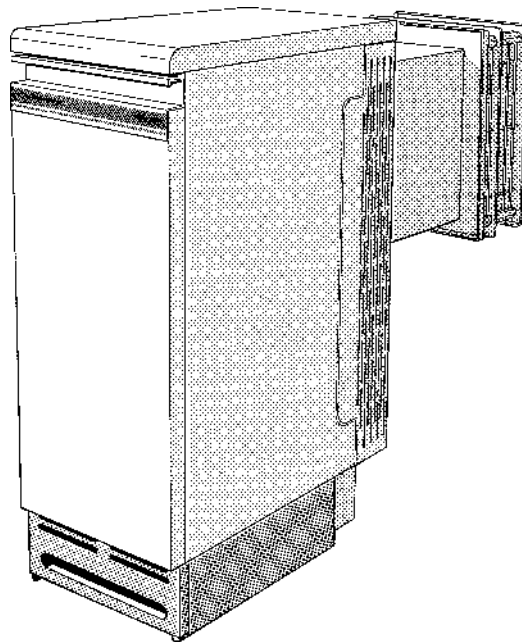

0863

The instructions consist of three parts, User, Installation and Servicing Instructions, which includes the Guarantee Registration Card. The instructions are an integral part of the appliance and must, to comply with the current issue of the Gas Safety (Installation and Use) Regulations, be handed to the user on completion of the installation.

Guarantee Registration

Thank you for installing a new Glow-worm appliance in your home.

Glow-worm appliances' are manufactured to the very highest standard so we are pleased to offer our customers' a Comprehensive First Year Guarantee.

In the centre pages are to be found your Guarantee Registration Card, which we recommend you complete and return as soon as possible.

If this card is missing you can obtain a copy or record your registration by telephoning the Heatcall Customer Service number 01773 828100.

Our Guarantee gives you peace of mind plus valuable protection against breakdown by covering the cost of:

- All replacement parts**
- All labour charges**
- All call-out charges**

REGISTER YOUR GLOW-WORM APPLIANCE
FOR 1ST YEAR GUARANTEE PROTECTION

CALL 0208 247 9857

HEATCALL

Customer Services:

Tel: (01773) 828100

One Contact Local Service Fax: (01773) 828070

Hepworth Heating Ltd.,

Nottingham Road, Belper, Derbyshire. DE56 1JT

General/Sales enquiries:

Tel: (01773) 824141 Fax: (01773) 820569

Important Information

Testing and Certification

This boiler is tested and certificated for safety and performance. It is therefore important that no alteration is made to the boiler, without permission, in writing, from Hepworth Heating Ltd.

Any alteration not approved by Hepworth Heating Ltd., could invalidate the certification, boiler warranty and may also infringe the current issue of the Statutory Requirements, see Section 1.4.

CE Mark

This boiler meets the requirements of Statutory Instrument No. 3083 The boiler (Efficiency) Regulations, and therefore is deemed to meet the requirements of Directive 92/42/EEC on the efficiency requirements for new hot water boilers fired with liquid or gaseous fuels.

Type test for purposes of Regulation 5 certified by: Notified body 0086.

Product/productioncertifiedby: Notified body 0086.

The CE mark on this appliance shows compliance with:

1. Directive 90/396/EEC on the approximation of the laws of the Member States relating to appliances burning gaseous fuels.
2. Directive 73/23/EEC on the harmonization of the Laws of the Member States relating to the electrical equipment designed for use within certain voltage limits.
3. Directive 89/336/EEC on the approximation of the Laws of the Member States relating to electromagnetic compatibility.

INFORMATION FOR THE INSTALLER AND SERVICE ENGINEER.

Under Section 6 of The Health and Safety at Work Act 1974, we are required to provide information on substances hazardous to health.

CERAMIC FIBRE/INSULATION PADS, GLASSYARN.

These can cause irritation to skin, eyes and the respiratory tract. If you have a history of skin complaint you may be susceptible to irritation. High dust levels are usual only if the material is broken. Normal handling should not cause discomfort, but follow normal good hygiene and wash your hands before eating, drinking or going to the lavatory. If you do suffer irritation of the eyes or severe irritation to the skin seek medical attention.

THERMOSTATS

These contain very small amounts of xylene in the sealed phial and capillary. If broken, under normal circumstances the fluid does not cause a problem, but in case of skin contact, wash with cold water. If swallowed drink plenty of water and seek medical attention.

CONTENTS	DESCRIPTION	SECTION	PAGE No.
INSTRUCTIONS FOR USE	Introduction		3
	Lighting the Boiler		4
INSTALLATION INSTRUCTIONS	General Data	1	5
	Water Systems	2	7
	Flue and Ventilation	3	8
	Installation	4	9
	Casing Location / Fitting	5	12
	Electrical Wiring	6	14
	Commissioning	7	15
SERVICING INSTRUCTIONS	Servicing	8	17
	Replacement Parts	9	18
	Fault Finding	10	21
	Spare Parts	11	24

Instructions for Use

General Information

Please read these instructions and follow them carefully for the safe and economical use of your boiler.

The boiler is automatic in operation, once the pilot has been lit and the controls set.

Glow-worm Hideaways are central heating boilers, to provide heating and if required, an indirect domestic hot water supply.

Important Notice

This boiler is for use only on G20 gas.

Gas Safety (Installation and Use) Regulations

In your own interests and that of safety, is the law that ALL gas appliances are installed by a competent person in accordance with the current issue of the above regulations.

Warning

Make sure that nothing obstructs the rear side grille or clearances. See page 4 for minimum clearances.

Boilers Installed in a Compartment

If the boiler is fitted in a compartment, cupboard etc., do not obstruct the purpose built compartment vents or the grille on the boiler.

Do not use the compartment for storage purposes.

Maintenance

To ensure the continued efficient and safe operation of the boiler it is recommended that it is checked and serviced as necessary at regular intervals. The frequency of servicing will depend upon the particular installation conditions and usage, but in general once a year should be enough.

It is the law that servicing must be carried out by a competent person.

If this appliance is installed in a rented property there is a duty of care imposed on the owner of the property by the current issue of the Gas Safety (Installation and Use) Regulations, Section 35.

To obtain service please call your installer or Heatcall (Glow-worm's own service organisation) using the telephone number given on the front panel.

Please be advised that the 'Benchmark' logbook should be completed by the installation engineer on completion of commissioning and servicing.

All CORGI Registered Installers carry a CORGI ID card, and have a registration number. Both should be recorded in your boiler Logbook. You can check your installer is CORGI registered by calling CORGI direct on :- 01256 372300.

Boiler Electrical Supply

WARNING. This boiler must be earthed.

The boiler must only be connected to a 230V-50Hz supply protected by a 3A fuse, maximum.

All wiring must be in accordance with the current issue of BS7671.

Heat resistant flexible cable having a conductor size of 0.75mm², to the current issue of BS6500 Table 16 must be used.

To Connect an Electrical Plug

The standard colours of three core flexible cable are, Brown - live, Blue - neutral, Green and Yellow - earth.

As the markings on your plug may not correspond with these colours, continue as follows:

The Blue cable must be connected to the terminal marked "N" or "Black".

The Brown cable must be connected to the terminal marked "L" or "Red".

The Green and yellow cable must be connected to the terminal marked "E" or "Green" or the earth symbol .

To Light the Boiler

WARNING. If the pilot light goes out for any reason, do not attempt to relight until 3 minutes have elapsed.

Remove the door by pulling forwards with the fascia at the top. Lift up to disengage from the bottom side lugs.

Refer to diagram 1 to identify controls.

Check that the mains electrical supply to the boiler is switched OFF.

Push in slightly and turn gas control knob "A" clockwise until ● is against its setting point.

Turn thermostat control knob "B" anticlockwise until "O" is against its setting point.

Push in slightly and turn gas control knob "A" anticlockwise until ★ is against its setting point, then depress fully and hold in.

Push in and release piezo ignition button "C" until the pilot burner lights.

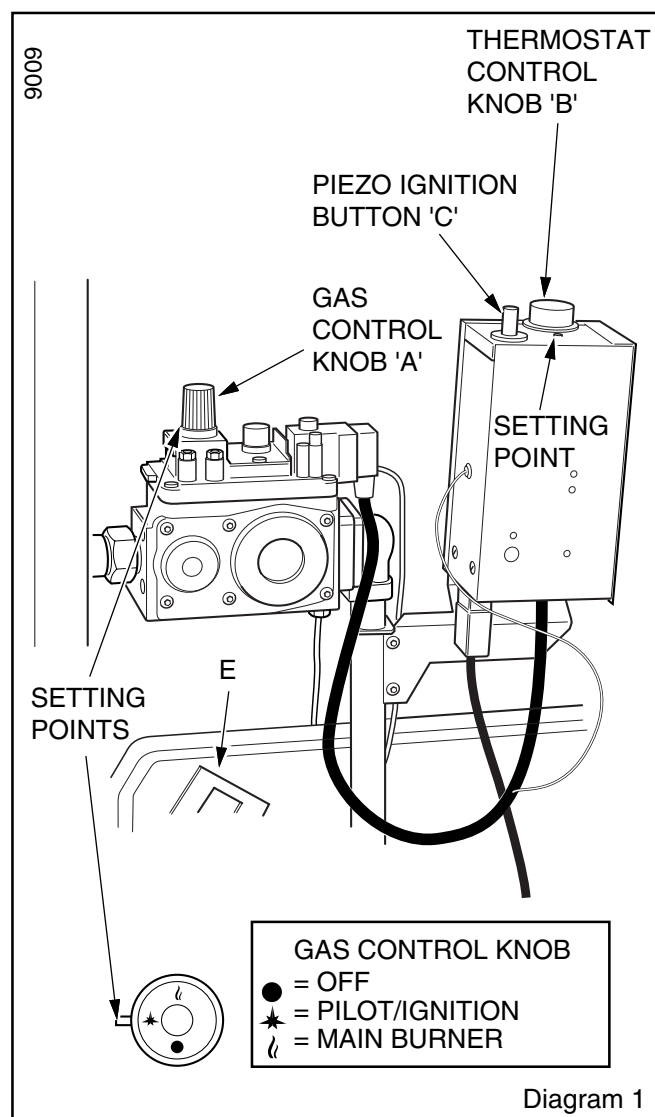



Instructions for Use

Air may be present in the supply pipe so the lighting of the pilot may need to be repeated until all the air has been expelled.

When the pilot is alight, view through window "E", keep gas control knob "A" fully pushed in for about 15 seconds, then release.

If the burner fails to stay alight, wait 3 minutes, then repeat the lighting procedure only now keep control knob "A" pushed in for a little longer before releasing.

Press in and turn gas control knob "A" anticlockwise until  is against its setting point.

If the gas control knob "A" is turned to , a safety lock prevents it being turned on again for a short period. No attempt should be made to relight the pilot until 3 minutes have elapsed.

Make sure that the pilot is alight and stable then switch on the electrical supply.

Set any system controls to "ON" or "HIGH".

Turn the boiler thermostat knob "B" clockwise until "MAX" is against its setting point and the main burner will light. Adjust thermostat to required setting between "MIN" and "MAX". "MAX" is about 82°C (180°F).

Refit the door by locating the hooked runner at the bottom into the slot in the side panels and pushing onto the studs.

To Turn the Boiler Off

For short periods, turn the boiler thermostat control knob "B" anticlockwise to "O". The pilot will stay alight. To relight the main burner turn thermostat control knob "B" clockwise to the desired setting between "MIN" and "MAX".

For longer periods, depress slightly and turn gas control knob "A" fully clockwise until  is against its setting point. Turn thermostat control knob "B" anticlockwise to "O". Isolate the boiler from the electrical supply. Follow full lighting procedure to relight. Refer also to "Protection Against Freezing".

Gas Leak or Fault

If a gas leak fault exists or is suspected the boiler must be turned off, including the electrical supply and must not be used until the fault has been put right. Advice/help should be obtained from the local gas undertaking or your installation/servicing company.

Protection Against Freezing

If the boiler is to be out of use for any period of time during severe weather conditions we recommend the whole system including the boiler, be drained off to avoid the risk of freezing up. If an immersion heater is fitted to the hot water cylinder make sure it is switched off.

Sheet Metal Parts

WARNING. This boiler contains metal parts (components) and care should be taken when handling and cleaning, with particular regard to edges.

Cleaning

Keep the casing clean by wiping it occasionally with a damp soapy cloth and dry with a polishing cloth.

Do not use abrasive cleaners.

Replacement Parts/Boiler Identification

If replacement parts are required apply to your local supplier. Please quote the name of the boiler and its serial number which can be found on the data label, positioned on the boiler top, to the rear of the inclined flueway cleaning door.

Clearances

Minimum clearances must be left around the boiler as shown in diagrams 1.3, 1.4 and 1.5.

General Data

* Refer to BOILER CASING HEIGHT diagram

† A SPECIAL TOP CASING TO SUIT 600mm (23⁵/₈ in.) WORKTOPS IS AVAILABLE

⌋ GAS CONNECTION
Rc 1/2 (1/2 in. B.S.P.T.)

⊕ WATER CONNECTIONS
Rc1 (1in. B.S.P.T.)

⊙ WATER CONNECTIONS Rc1 reduced with DISTRIBUTOR TUBE to Rc 3/4 (3/4 in. B.S.P.T.) (pumped return)

1071

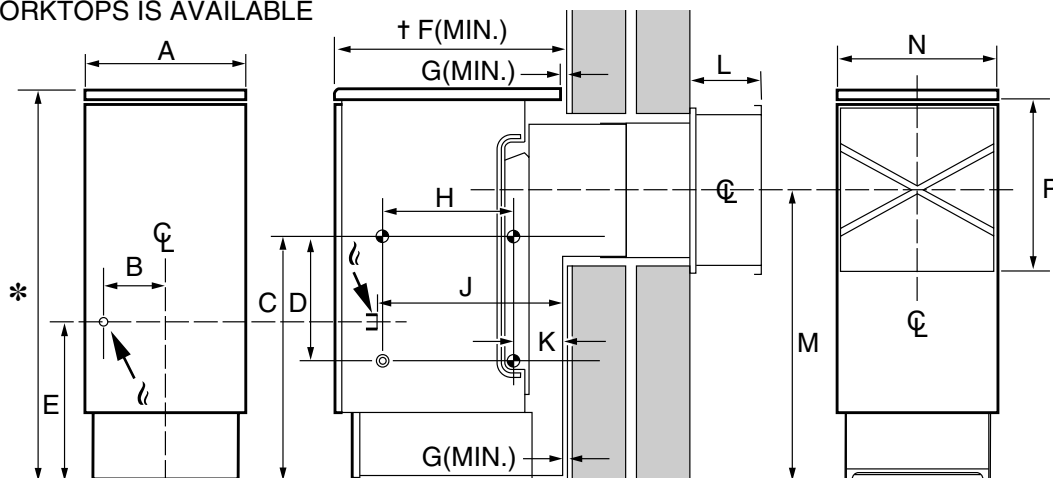

GENERAL DIMENSIONS - given in millimetres (Approx. inches)

Diagram 1.1

	A	B	C	D	E	†F	G	H	J	K	L	M	N	P
mm	387	171	558	294	363	533	3	300	445	121	156	664	292	398
in.	15 ¹ / ₄	6 ³ / ₄	22	11 ¹ / ₂	14 ¹ / ₄	21	1/8	11 ³ / ₄	17 ¹ / ₂	4 ³ / ₄	6 ¹ / ₈	26 ¹ / ₈	11 ¹ / ₂	15 ⁵ / ₈

Important Notice

This boiler is for use only on G20 gas.

Wherever possible, all materials, appliances and components to be used shall comply with the requirements of applicable British Standards.

Where no British Standard exists, materials and equipment should be fit for their purpose and of suitable quality and workmanship.

1.1 Data

Weight of boiler	105.8kg (232lb)
Water content	8.64litre (1.9 gall)
Gas connection	Rc1/2 1/2 inBSP
Water connection	Rc1 1 in BSP
Electrical supply	230V ~ 50Hz fused 3A
Burner	Aeromatic

All dimensions are given in millimetres (except as noted).

The Seasonal Efficiency Domestic Boilers UK (SEDBUK) is 72.6%.

The value is used in the UK Government's Standard Assessment Procedure (SAP) for energy rating of dwellings. The test data from which it has been calculated have been certified by B.S.I.

1.2 Range Rating

This boiler is range rated and may be adjusted to suit individual system requirements.

The tables give the appropriate settings and ratings.

The boiler heat input is factory preset to its maximum rating. This should be adjusted to suit individual system requirements.

The arrow indicator, from the loose items pack, should be stuck on the data label to indicate the setting.

1.3 Sheet Metal Parts

WARNING. When installing or servicing this boiler, care should be taken to avoid any possibility of personal injury when handling sheet metal parts.

1.4 Statutory Requirements

The installation of this boiler must be carried out by a competent person in accordance with the relevant requirements of the current issue of:

Manufacturer's instructions, supplied.

The Gas Safety (Installation and Use) Regulations, The Building Regulations, Local Water Company Bye-laws, The Building Standards (Scotland) Regulations (applicable in Scotland) Health and Safety at Work Regulations, Control of Substances Hazardous to Health, Electricity at Work Regulations and any applicable local regulations.

Detailed recommendations are contained in the current issue of the following British Standards and Codes of Practice,

BS6891, BS5440 Part 1 and 2, BS6798, BS5449, BS5546, BS6700, BS7478, BS7593, BS7671.

Manufacturer's instructions must not be taken as overriding statutory requirements.

RANGE RATING		min	medium	max
NOMINAL HEAT INPUT (GROSS)	<i>kW</i>	25.76	27.58	29.41
	<i>Btu/h</i>	87,900	94,100	100,350
NOMINAL HEAT OUTPUT	<i>kW</i>	20.52	21.98	23.45
	<i>Btu/h</i>	70,000	75,000	80,000
BURNER SETTING PRESSURE (HOT)	<i>mbar</i>	11.5	13.2	15.2
	<i>in.w.g</i>	4.6	5.3	6.1
INJECTOR		205749		

General Data

1.5 B.S.I. Certification

This boiler is certified by B.S.I. for safety and performance. It is, therefore, important that no alteration is made to the boiler, without permission, in writing, from Hepworth Heating Ltd.

Any alteration not approved by Hepworth Heating, could invalidate the B.S.I. certification, boiler warranty and could also infringe the statutory requirements.

1.6 Gas Supply

The gas installation shall be in accordance with the current issue of BS6891.

The supply from the governor meter must be of adequate size to provide a steady inlet working pressure of 20mbar (8in wg) at the boiler.

1.7 Electrical

WARNING. This boiler must be earthed.

The electrical installation must be carried out by a competent electrician. All external components shall be of the approved type and shall be connected in accordance with the current issue of BS7671 and any local regulations which apply.

Connection of the boiler and any system controls to the mains supply through an unswitched shuttered socket outlet and 3A fused 3 pin BS1363 plug. Alternatively, a 3A fused double pole isolating switch may be used, having a minimum double pole contact separation of 3mm, serving the boiler and system controls only.

Heat resistant flexible cable of at least 0.75mm² (24/0.20mm) to BS6500 Table 16, must be used for all connections within the boiler casing.

1.8 Boiler Location

This boiler is not suitable for outside installation.

The boiler may be installed in any room, although particular attention is drawn to the requirements of the current issue of BS7671 with respect to the installation of the boiler in a room containing a bath or shower. Any electrical switch or boiler control utilising mains electricity should be so situated that it cannot be touched by a person using the bath or shower. The electrical provisions of the Building Standards (Scotland) Regulations are applicable to such installations in Scotland.

The boiler must stand on a level floor, conforming with the local authority requirements and building regulations. The base temperature is within the requirements of BS5258. The boiler may be stood on a wooden floor but a metal base plate is required to protect plastic tiles and similar floor coverings.

Suitable clearance needs to be available at the sides of the boiler to facilitate direct connection of pipework and making good around the flue assembly. The actual clearance required will vary with site conditions.

The casing can be fitted to the boiler at various heights. The top casing can be discarded, if preferred, when fitting the boiler under a worktop or fixture, see diagram 1.2.

When the boiler is to be installed level with work surfaces etc., minimum clearances should be provided as shown in diagram 1.3. Work tops which overhang the cupboard sides almost in contact with the casing top, require a larger minimum air gap. Flush sided fixtures require the same overall minimum space but can have a reduced air gap on one side.

Boilers to be installed under work tops or fixtures, with or without the casing top fitted, should be positioned to provide minimum clearances as shown in diagram 1.4.

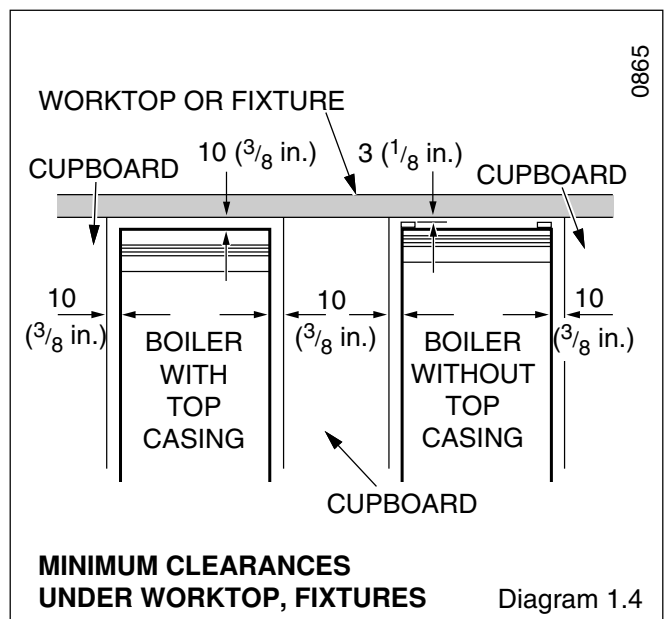
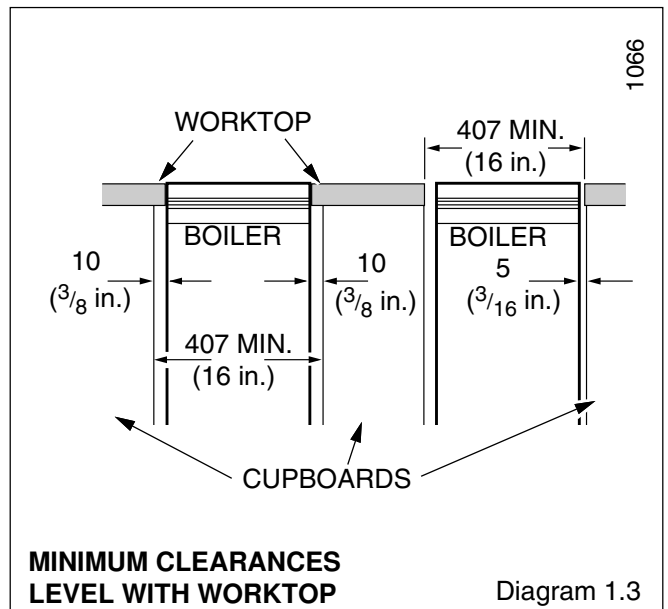
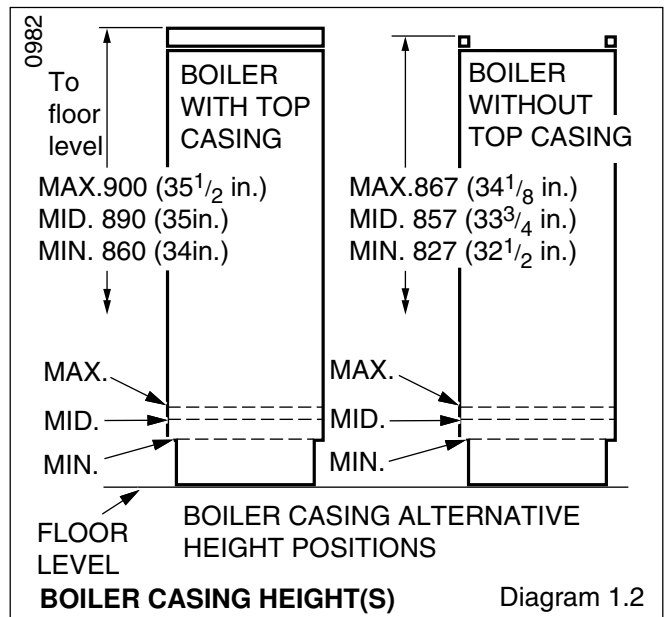

1 General Data

To facilitate minimum clearances it may be necessary to modify the kitchen units or fixtures, depending upon which type of connections are used.

A front access clearance should be provided as shown in diagram 1.5.

The minimum gap behind the top casing is as shown in diagram 1.1. The boiler can be sited further away from the wall if required to align with kitchen units etc. Refer to Section 3.5.

Combustible wall material must be 25mm (1in) away from flue components. Refer to Section 3.5.

A special top casing, part No. 425524, can be purchased to enable the boiler casings to be arranged flush with 600mm (23⁵/₈in) deep work tops and kitchen units.

Where the installation of the boiler will be in an unusual location, special procedures are necessary, the current issue of BS6798 gives guidance on this.

A compartment used to enclose the boiler must be designed and constructed specifically for this purpose. An existing cupboard or compartment modified for the purpose may be used. Details of essential features of cupboard design are given in the current issue of BS6798.

If the boiler is to be installed in a compartment, make sure that nothing will obstruct the openings/vents in the compartment.

1.8 Heating System Controls

The heating system should have installed: a programmer and room thermostat controlling the boiler.

Thermostatic radiator valves may be installed in addition to the room thermostat.

Note: For further information, see The Building Regulations 1991 - Conservation of fuel and power, 1995 edition - Appendix G, table 4b.

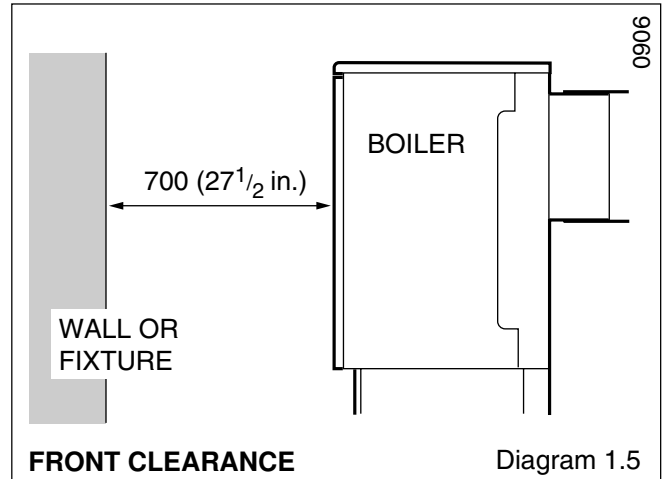

2 Water Systems

2.1 Water Pressure Head

This boiler shall only be connected to a cistern supply, with a minimum head of 1 metre (3ft) and a maximum of 27 metres (90ft) and having an open vent in the system.

The boiler must not be connected to a sealed water system.

2.2 Inhibitor

Attention is drawn to the current issue of BS5449 and BS7593 on the use of inhibitors in central heating systems.

When an inhibitor is to be used in the system, contact should be made with an inhibitor manufacturer so they can recommend their most suitable product.

When using in an existing system take special care to drain the entire system, including the radiators, then thoroughly cleaning out before fitting the boiler whether or not adding an inhibitor.

2.3 Gravity Domestic and Pumped Heating

It is recommended that a cylinder thermostat is used to prevent the stored water temperature becoming unnecessarily high.

The primary flow and return must be 28mm. The installation must comply with the current issue of BS5546 and BS6700, see diagram 2.1.

If the above conditions cannot be met, it is suggested that a fully pumped system be used.

2.4 Fully Pumped System

Where a single pumped, flow and return is taken from the boiler, refer to diagram 2.2.

2.5 Circulation Pump

The pump should be set to give a temperature difference of 11°C (20°F) across the system. At the appropriate flow rate the resistance through the boiler can be found from the pressure loss graph, diagram 2.3.

If possible use a pump with integral valves, if not fit valves as close as possible each side of the pump.

Note: If the pump is to be fitted inside the boiler casing a heat shield kit is required. Kit No. 425838.

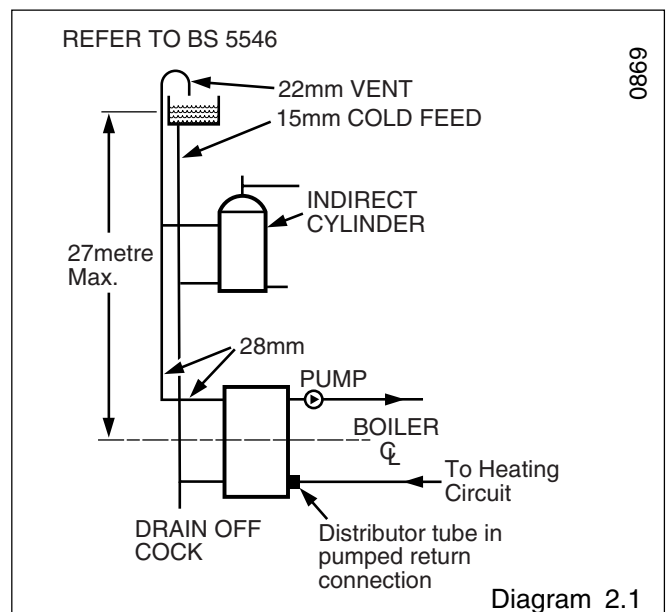

2 Water Systems

2.6 Cylinder

For all systems supplying domestic hot water the cylinder must be indirect and to the appropriate British Standard.

2.7 Safety Valve

A safety valve need not be fitted to an open vented system.

2.8 Drainage

A drain tap must be provided at the lowest points of the system which will allow the entire system, including the boiler and domestic hot water cylinder to be drained. Drain taps shall comply with the current issue of BS2879.

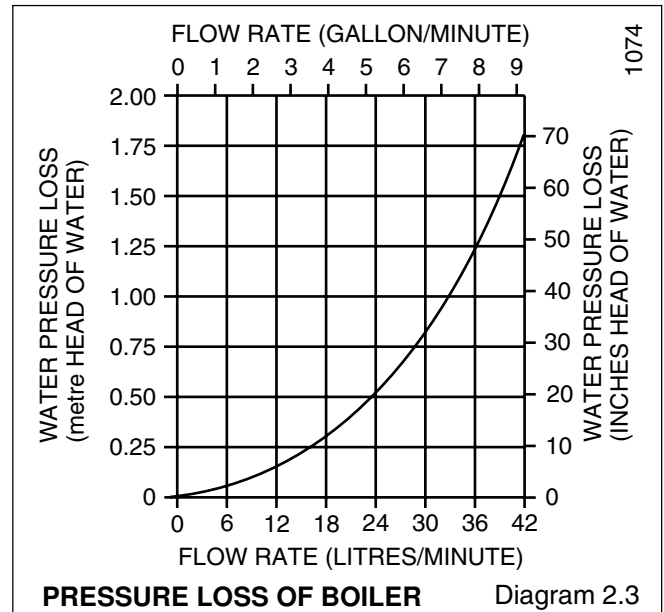
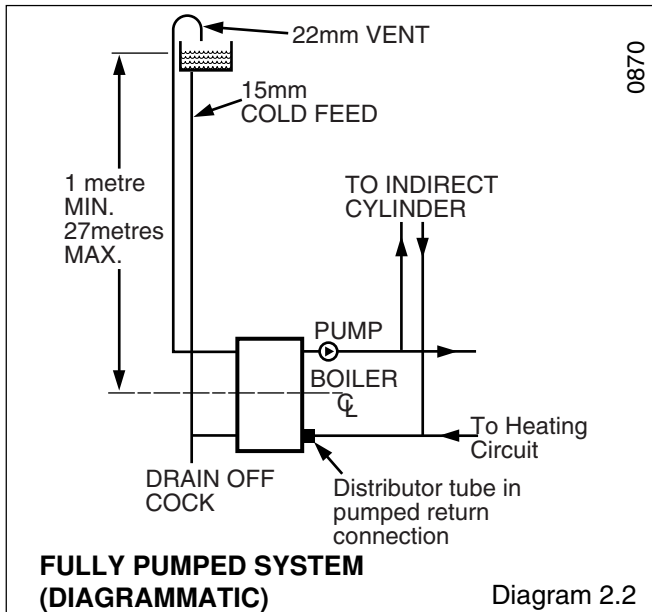

3 Flue and Ventilation

3.1 Flue

Detailed recommendations for flues are given in the current issue of BS5440 Part 1.

The boiler must be installed so that the flue terminal is exposed to the external air. It is important that the position allows the free passage of air across it at all times.

3.2 Terminal Positioning

The minimum acceptable spacings for the terminal to obstructions, other terminals and ventilation openings are given in diagram 3.1.

Car port or similar extensions of a roof only, or roof and one wall, require special action with regard to openings, doors and windows under the roof. Care is required in protecting plastic roofs. If the car port consists of a roof and two or more walls seek advice from the local gas region.

Where the terminal is within 850mm (34in) below plastic guttering, or within 450mm (18in) of painted eaves or gutter an aluminium shield 1.5 metres (5ft) long should be fitted to the underside and immediately beneath the guttering.

The air inlet/products outlet duct and the terminal of the boiler must not be closer than 25mm (1in) to combustible material.

3.3 Timber Frame Buildings

If the boiler is to be installed in a timber frame building it should be fitted in accordance with the Institute of Gas Engineers document IGE/UP/7/1998. If in doubt seek advice from the local gas undertaking or Hepworth Heating Ltd.

3.4 Protecting the Terminal

A terminal guard is required if persons could come into contact with the terminal or the terminal could be subject to damage.

If a terminal guard is required, it must be positioned to provide a minimum of 50mm clearance from any part of the terminal and be central over the terminal.

A suitable guard is available from

Tower Flue Components Ltd.,
Morley Road,
Tonbridge,
Kent.
TN9 1RA

reference type "F"

3.5 Flue Duct Length

The flue lengths quoted below allow the minimum rear clearance of 3mm ($\frac{1}{8}$ inch) behind the boiler, although the boiler can be installed further away from the inside wall. In such cases any extra clearance behind the boiler must be added to the wall thickness to obtain the flue duct length.

Check the wall thickness/flue duct length where the boiler is fitted. Flues available are:

- Standard pack - 280 to 410mm (11 to 16inches)
- Short pack - 150 to 280mm (6 to 11inches)
- Extension Kit (+standard pack) 410 to 610mm (16 to 24inches)

The short flue pack, 424638 and the extension kit, 424680 are available to order. Standard pack is 424604.

3 Flue and Ventilation

3.6 Room Ventilation

The boiler is room sealed and does not require the room or space containing it to have permanent air vents.

3.7 Cupboard/Compartment Ventilation

Where the boiler is fitted in a cupboard or compartment, the high and low level permanent air vents must have effective areas in accordance with the Compartment Air Vent Table.

Both the high level and the low level air vents must communicate with the same room, or must both be on the same wall to outside air.

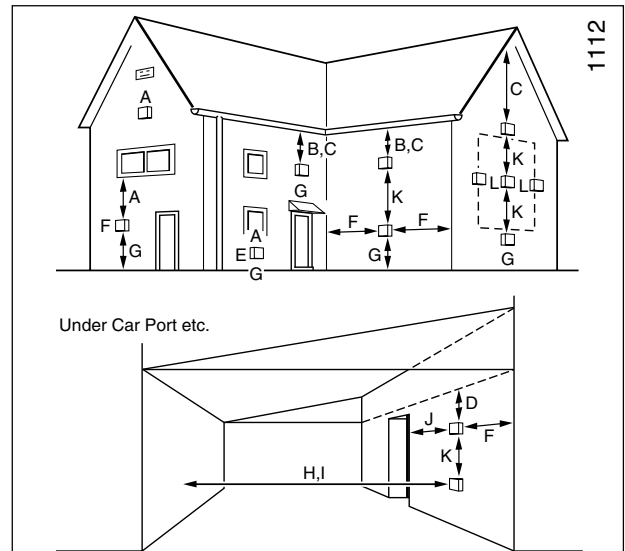

MINIMUM SITING DIMENSIONS FOR BALANCED FLUE TERMINALS		
POSITION		MINIMUM SPACING
A	DIRECTLY BELOW AN OPENABLE WINDOW, AIR VENT, OR ANY OTHER VENTILATION OPENING	mm
B	BELOW GUTTER, DRAIN/SOIL PIPE	300
C	BELOW EAVES	300
D	BELOW A BALCONY OR CAR PORT	600
E	FROM VERTICAL DRAIN PIPES AND SOIL PIPES	75
F	FROM INTERNAL OR EXTERNAL CORNERS	600
G	ABOVE ADJACENT GROUND OR BALCONY LEVEL	300
H	FROM A SURFACE FACING THE TERMINAL	600
I	FACING TERMINALS	600
J	FROM OPENING (DOOR/WINDOW) IN CARPORT INTO DWELLING	1200
K	VERTICAL FROM A TERMINAL	1500
L	HORIZONTALLY FROM A TERMINAL	300

Diagram 3.1

COMPARTMENT AIR VENT TABLE

COMPARTMENT VENTILATION REQUIREMENTS	HIGH LEVEL VENT AREA		LOW LEVEL VENT AREA	
	VENTILATION FROM ROOM OR SPACE	272cm ²	42in ²	272cm ²
FROM OUTSIDE	136cm ²	21in ²	136cm ²	21in ²

4 Installation

Before fixing the boiler make sure that the location selected is in accordance with the requirements of Section 1.8 "Boiler Location".

4.1 Unpacking

Remove the packaging and then the boiler from its pallet by removing the screws.

The boiler casing panels are packed separately within the main carton. They are designed to enable gas and water connections to be made before fitting the casing.

The casing brackets, distributor tube and loose items, in a plastic bag, are packed in the corner fitment.

4.2 Casing Brackets

Fit the two upper and two front casing brackets as shown in diagram 4.1 using eight of the No.8 screws.

Push the captive nuts, supplied loose, on to the casing brackets as shown in diagram 4.1.

4.3 Planning Water Connections - Gravity Domestic and Pumped Heating.

It is important that all connections are made as illustrated in diagram 4.2.

Heating flow, either one of the two upper front connections may be used.

Domestic gravity flow, any one of the three remaining upper connections may be used.

Heating return, the water distributor tube MUST be fitted into either one of the front lower connections on all installations, see diagram 4.3. The distributor tube is packed in the top fitment.

4 Installation

Domestic gravity return, any one of the three remaining lower connections may be used for the gravity domestic hot water return.

Fit plugs into all unused connections.

NOTE, if only limited clearance is available it is recommended that the front tapings are used.

4.4 Planning Water Connections - Fully Pumped Systems.

It is important that all connections are made as shown in diagram 4.4.

Flow, either one of the two upper front connections may be used.

Return, the water distributor tube **MUST** be fitted into the return connection on all installations, see diagram 4.3. The distributor tube is packed in the top fitment.

4.5 Thermostat Pocket

Fit the thermostat phial pocket, supplied in the top fitment, into the front tapping adjacent to the heating flow connection and plug the other front pocket connection.

Carefully unwind the thermostat capillary, insert phial fully into the pocket and secure with the location washer behind the retaining split pin, supplied in the loose items pack, see diagram 4.5.

4.6 Pump Within Boiler Casing

If the pump is to be fitted inside the boiler casing, see diagram 6.2, ensure that a heat shield kit is obtained and fitted (Kit No. 425838).

The kit contains a flueway cleaning door with heat shield (attached).

4.7 Positioning/Connecting Boiler

If the boiler casings are to fit flush with any kitchen units, the distance the boiler is away from the wall must be measured and dimension "G" increased by this amount, see diagram 1.1.

Having selected the position of the boiler, mark out and cut a hole through the wall where the boiler is to be installed, to the dimensions shown in diagram 4.6, after checking that sufficient clearances will be left around the boiler as described in Section 1.8 "Boiler Location", refer also to Section 3.5 "Flue Duct Length".

Fit the distributor tube, see diagram 4.2 or 4.4 for position, see diagram 4.3 for alignment. Fit appropriate fittings and plugs into the boiler connections.

IMPORTANT NOTE, do not route any pipes across the front of the boiler thermostat pocket, the controls, burner supply pipe, combustion chamber cover or flueway cleaning door. The gas supply pipe should be run along the left-hand side of the boiler.

If the flue duct length necessitates the use of the flue extension kit, that is 410 to 610mm (16 to 24inches) this will need to be assembled before positioning the boiler. Read the separate instructions supplied with the kit in conjunction with Section 4.8 "Balanced Flue Terminal".

When suitable installation clearances are available, position the boiler in readiness to connect pipework.

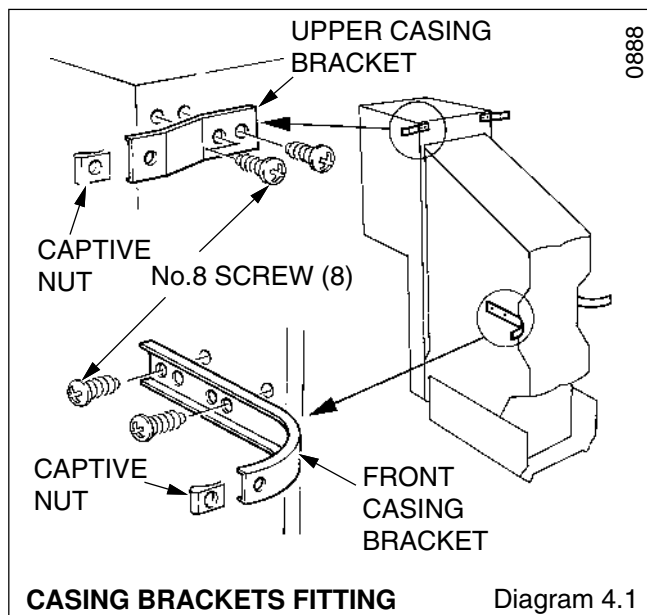

CASING BRACKETS FITTING Diagram 4.1

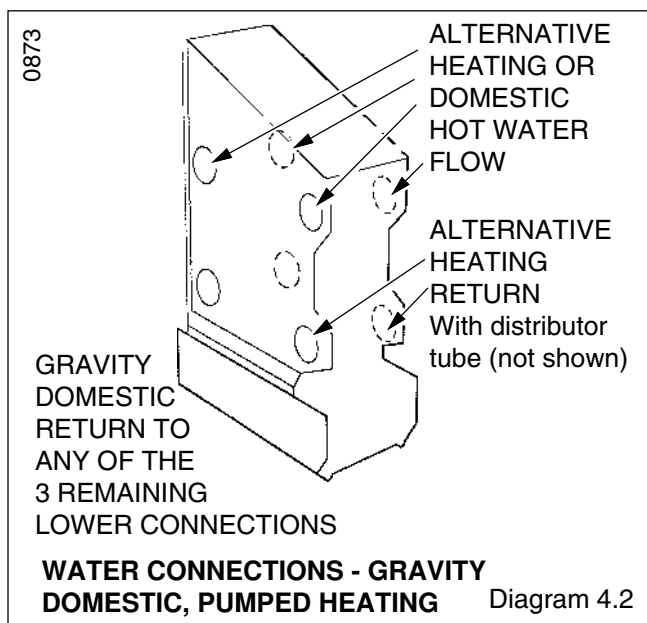

WATER CONNECTIONS - GRAVITY DOMESTIC, PUMPED HEATING Diagram 4.2

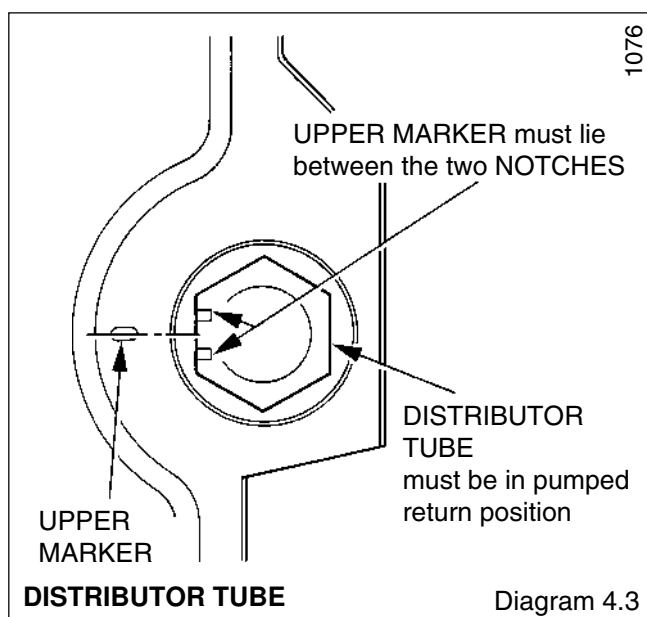

DISTRIBUTOR TUBE Diagram 4.3

4 Installation

If suitable clearances are not available it will be necessary to pre-plumb the gas and water connections prior to positioning the boiler.

When the front tapings are used it is essential that any pipework or fittings be assembled as shown in diagram 4.7, that is, do not stick out more than shown.

When using a rear tapping with Rc1 (1inch BSP) fittings for 28mm o.d. pipework it is recommended that a short nipple and a R thread (BSP) copper elbow is used. If the pipework is required to run back to the wall make sure that it will clear the boiler air duct and, if working to minimum clearance does not stick out too far from the boiler, see diagram 4.8.

Make the water connections to the system pipework.

Make the connection to the gas supply at the union gas service cock. Test the complete gas installation for soundness and purge in accordance with the current issue of BS6891.

When the boiler is finally positioned with the balanced flue duct sticking out into the prepared hole in the wall and pipework connected, make good to the inside of the wall face around the boiler flue assembly.

4.8 Balanced Flue Terminal

Take the balanced flue assembly from its carton and remove the four screws to release the outer baffle, see diagram 4.9.

Remove the four outer wire guards then pull off the inner baffle/flue duct assembly.

Place the air duct assembly into the prepared hole, from the outside, engaging it over the boiler air duct. Slide it until the wall plate contacts the outer wall surface.

Cut and fix four pieces of the yellow tape provided into the four corners at the joint in the air duct, running the tape on the inside of the duct about 25mm (1inch) along the joint from the corners. Fix four further pieces along the joints overlapping the corner tapes, to make a good seal.

Cement around the wall plate to make good and provide a weatherproof seal.

Refit the inner baffle/flue duct assembly over the boiler flue duct and slide in until the baffle contacts the wire guards.

Seal the flue duct joint on the inside using the semi-transparent, heat resistant, tape provided, in a similar way to the air duct sealing procedure, making sure that a good seal is made at the corners.

Refit the wire guards, outer baffle and secure with the screws previously removed.

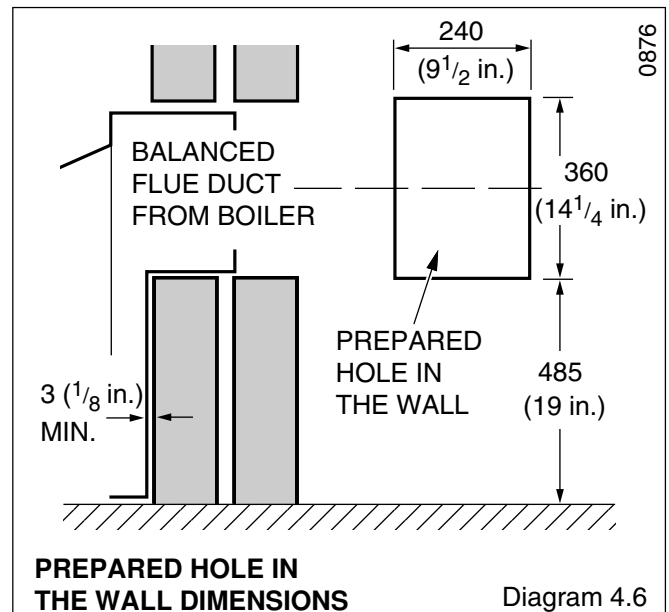
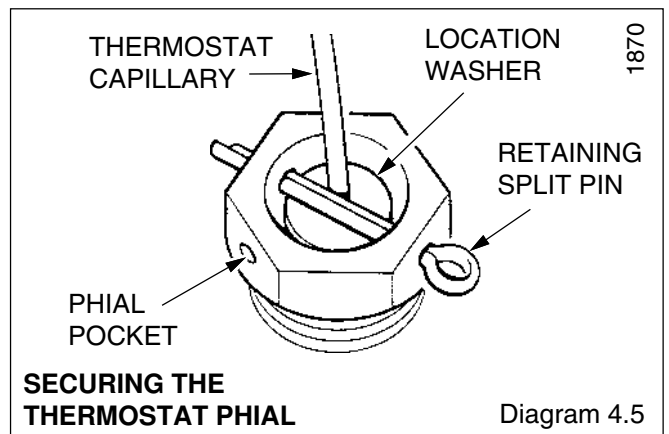
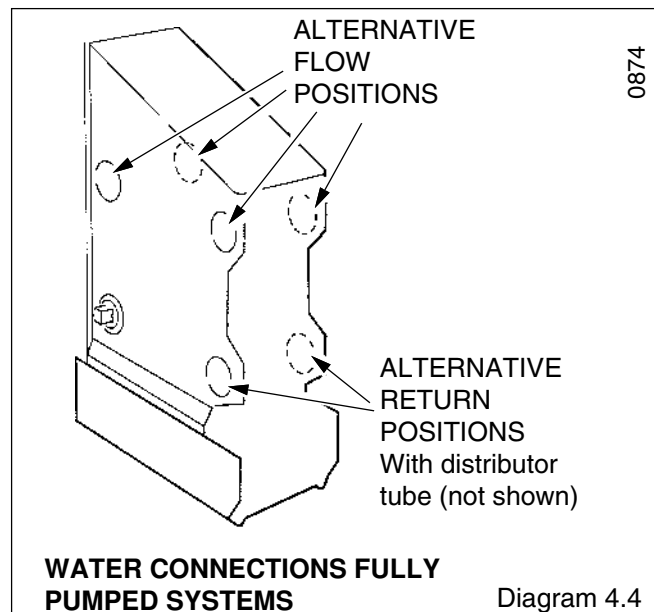

4 Installation

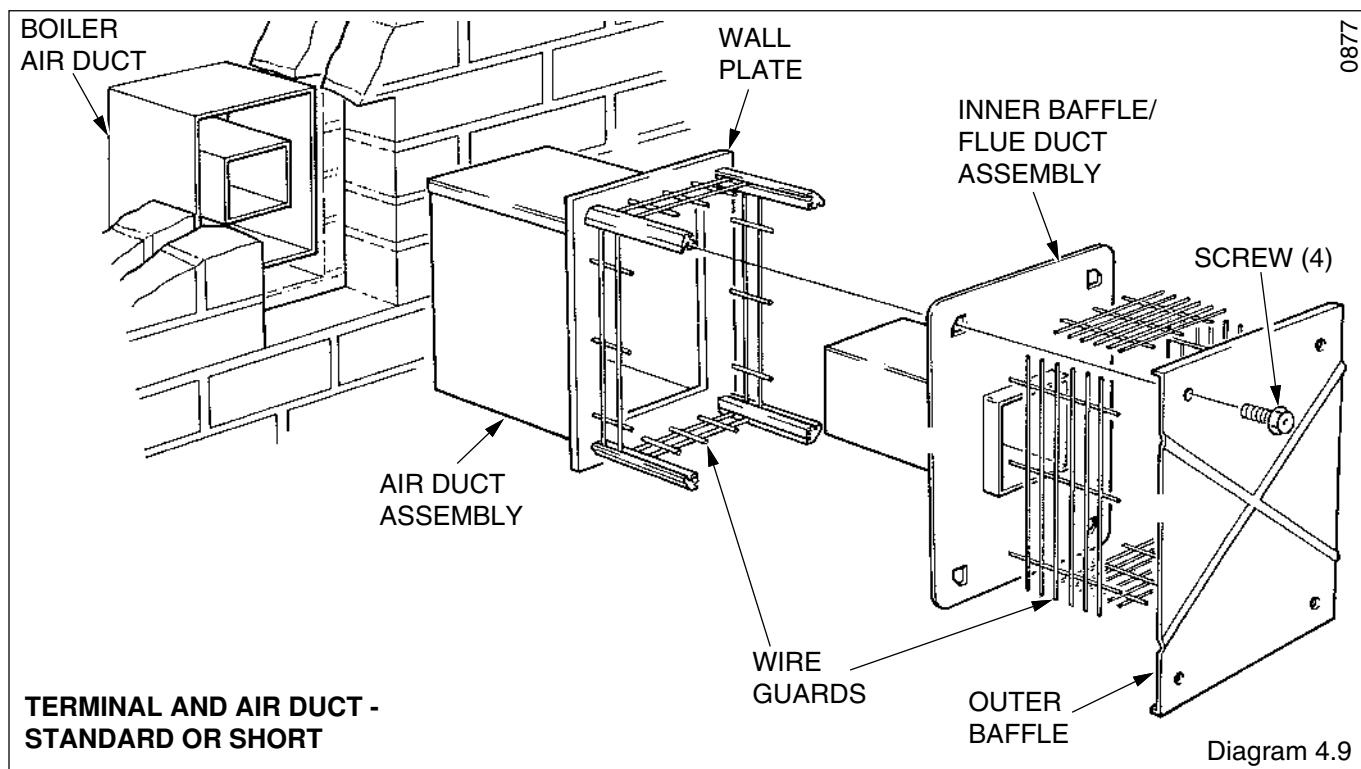
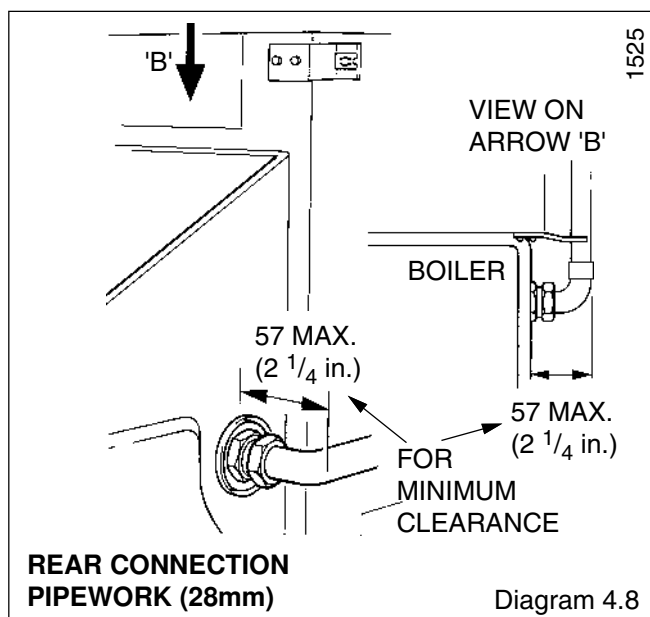
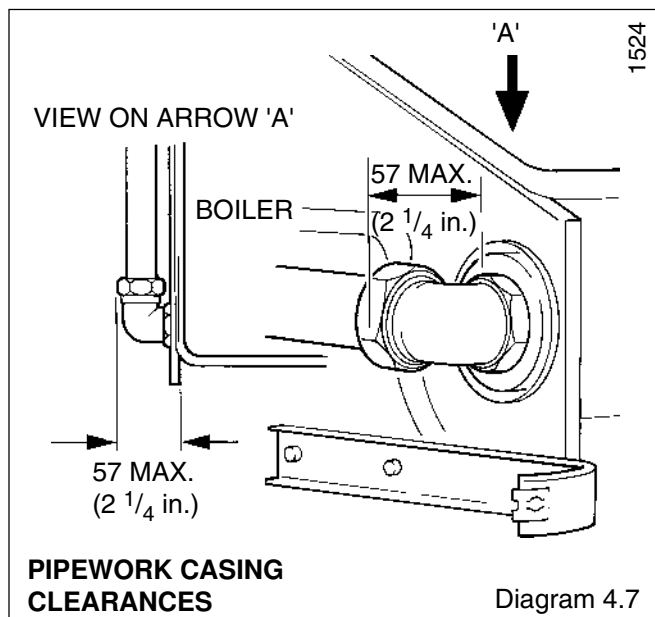

5 Casing Location / Fitting

5.1 Side Vent Grille

One side vent grille is supplied with the boiler and can be fitted at the rear of the left or right hand side casing. The grille is fitted on the opposite side to any pipework connections.

If required, fit the grille, using plastic pegs at the top and bottom, see diagram 5.1, prior to fixing the side casing. The plastic pegs are a tight fit, so they are best pushed home with a flat faced tool.

Discard the grille if water connections are made on both sides of the boiler or if the boiler is screened by fixtures.

5.2 Side Casings

Fit each side casing by locating the lugs into the appropriate slots in the boiler plinth, see diagram 5.2, depending on the required casing height, see diagram 1.2.

Secure the side casings to the casing brackets at the front and top.

5 Casing Location / Fitting

5.3 Top Casing

The top casing can be fitted in four alternative positions, that is, with either a rolled or square front edge, flush with the door or overhanging it.

Select either a rolled or square front edge and for a flush fitting top casing, fit four plastic pegs into holes "A" as shown in diagram 5.3. For overhanging top casing, fit four plastic pegs into holes "B". The plastic pegs are a tight fit so they are best pushed home with a flat faced tool.

Fit the top casing by engaging the pegs in to the holes in the side casings and then make sure they are fully engaged by pushing the pegs down.

For boilers fitted under work tops, not using the casing top, the strap should be fitted as diagram 5.4.

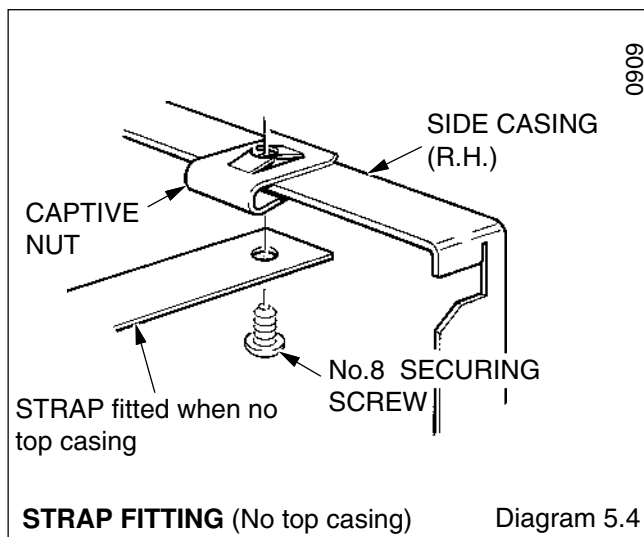
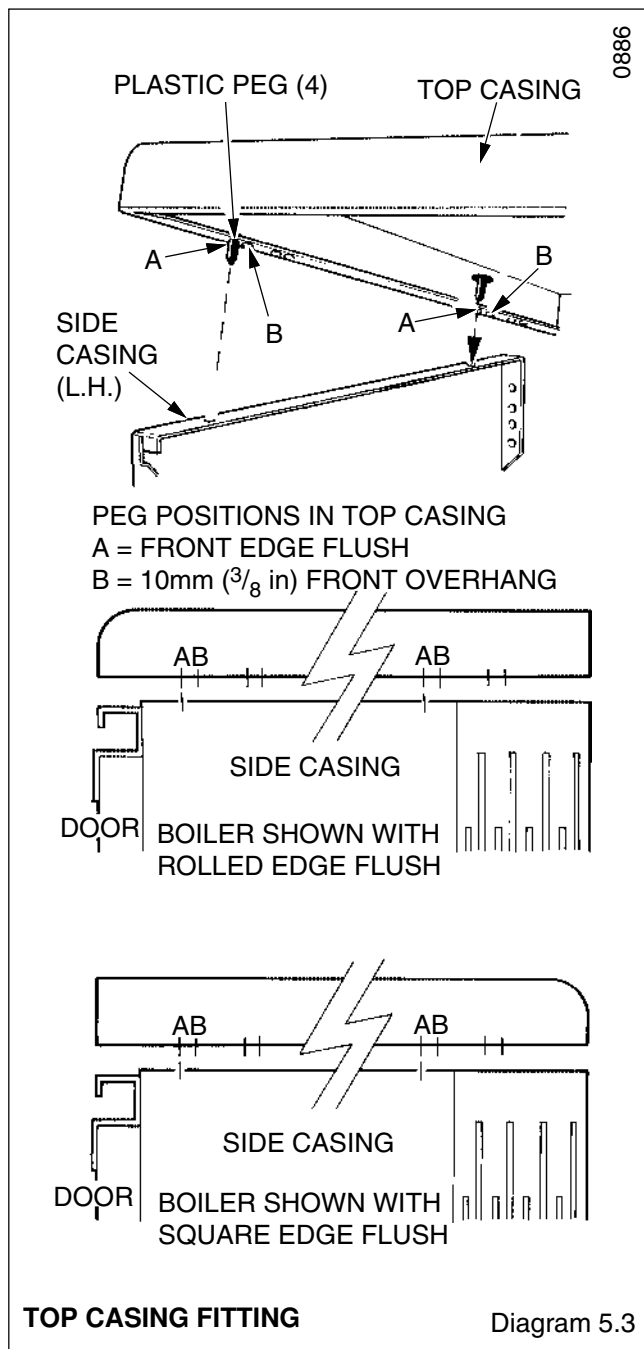
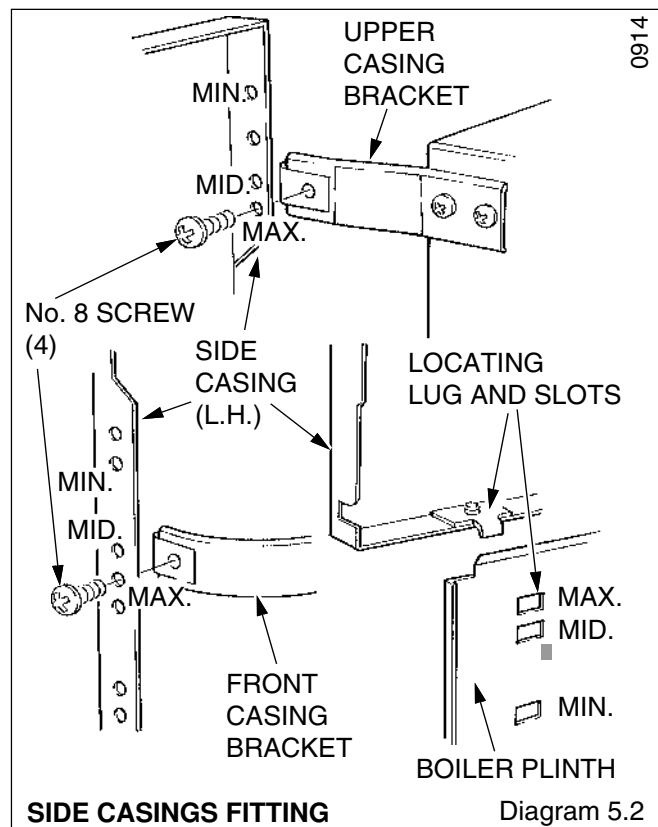
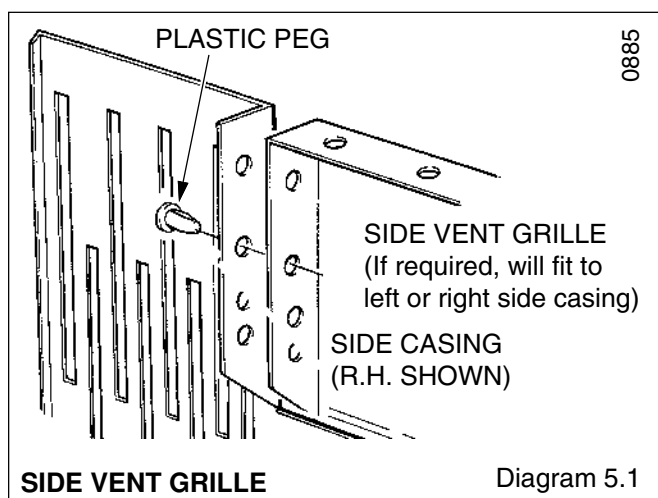

6 Electrical Wiring

6.1 Control Box Cable Connection.

Remove the screw and cover from the mains inlet connector, supplied loose, see diagram 6.1.

Using heat resistant flexible cable of a suitable length and rating as stated in Section 1.7 "Electrical" connect the three wires to the appropriate terminals in the connector.

Engage slots and lugs, replace cover and secure with screw.

Connect the mains inlet connector to the control box and use three of the cable clips, from the loose items pack, pushed onto the edge of the right hand panel in position CB as shown on diagram 6.2 to ensure the cable does not touch any hot surfaces.

6.2 Pump Cable Connection

Heat resistant cable as above must be used if the pump is to be fitted inside the casing.

Support the cable in a similar manner to Control Box Connection, only fit clips to the casing at P or AP as diagram 6.2.

6.3 System Controls

The electrical installation must be made in accordance with the current issue of BS7671.

The electrical isolator must isolate both the appliance and system controls.

6.4 Testing

Checks to ensure electrical safety should be carried out by a competent person.

In the event of an electrical fault after installation of the boiler, preliminary system checks must be carried, that is, earth continuity, polarity and resistance to earth, as described in the British Gas Multimeter Instruction Book or equal publication.

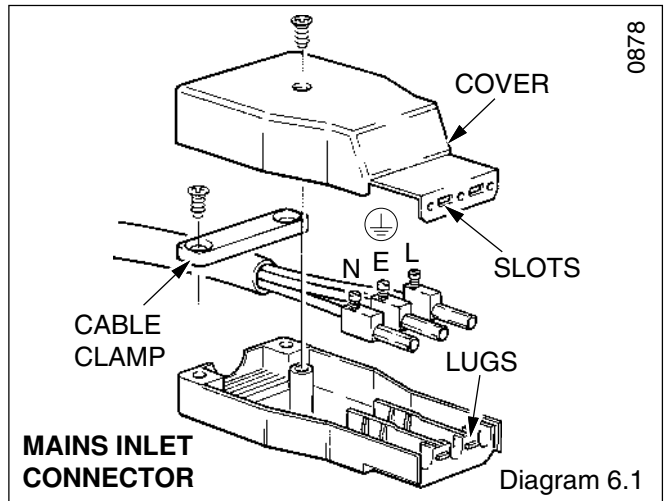
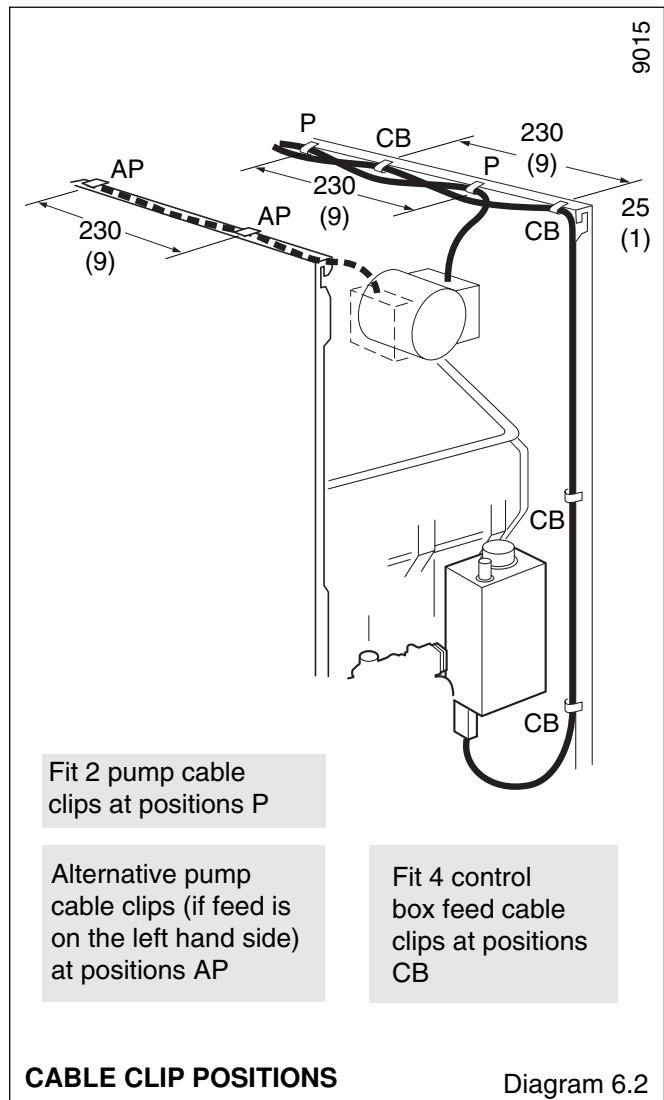

Diagram 6.1



CABLE CLIP POSITIONS

Diagram 6.2

7 Commissioning

Please ensure the "Benchmark" logbook is completed and left with the user.

7.1 Preliminaries

With the pump removed the whole of the system should be thoroughly flushed out with cold water.

Refit the pump and fill the system. Examine for water soundness and vent all air from the system and pump. Make sure that all valves are open.

7.2 Initial Lighting, Testing and Adjustment

CAUTION. The following should be carried out by a competent person.

Identify the boiler controls by reference to diagram 7.1.

Check that the gas service cock "K" is closed, indicator slot vertical.

Make sure that the thermostat phial is fully inserted in the phial pocket "J" and is securely located by the retaining split pin.

Check that the mains electrical supply is switched off.

Set thermostat control knob "B" to "O".

Remove the burner pressure test point screw "G" and connect a suitable pressure gauge.

Open gas service cock "K", indicator, horizontal.

Turn gas control knob "A" to ★ pilot/ignition position and depress. At the same time push and release piezo ignition button "C" until the pilot burner lights, view through window "E". At this stage air may be present in that gas pipes, so this operation may need to be repeated several times. When the pilot burner lights, keep control knob "A" fully pushed in for about

15 seconds. If the pilot burner fails to stay alight, repeat the lighting procedure only now keep the control knob pushed in for a little longer.

If the gas control knob "A" is turned to a ● safety lock prevents it being turned on again until 3 minutes have elapsed.

Make sure that the pilot is alight and stable, see diagram 7.2 for the approximate flame length. Switch on the electrical supply. Set any remote controls so that they are calling for heat. Turn control knob "A" to ④ main burner position. Set the thermostat control knob "B" between "MIN" and "MAX", the main burner will light. "MAX" is about 82°C (180°F).

Test for gas soundness around boiler gas components with a suitable leak detection fluid.

Ten minutes after lighting, check the burner setting pressure and adjust, if necessary, as follows, remove cover "F", see diagram 7.1 and turn adjustment screw anti-clockwise to decrease, see Data Table or refer to "L" Data Label for setting pressure. After adjusting replace cover.

If any doubt exists, the gas rate should be checked at the gas meter, this should be in the range:

Hideaway 80B - 2.5 to 2.8m³/h 87 to 99ft³/h

Stick the self-adhesive arrow indicator, from the loose items pack, to the data label against the rating the boiler is to be set to.

Allow the water system to reach maximum working temperature and examine for water soundness. The system should then be turned off and drained rapidly, whilst still hot, to complete the flushing process.

The system should then be filled again, vented and examined for water soundness.

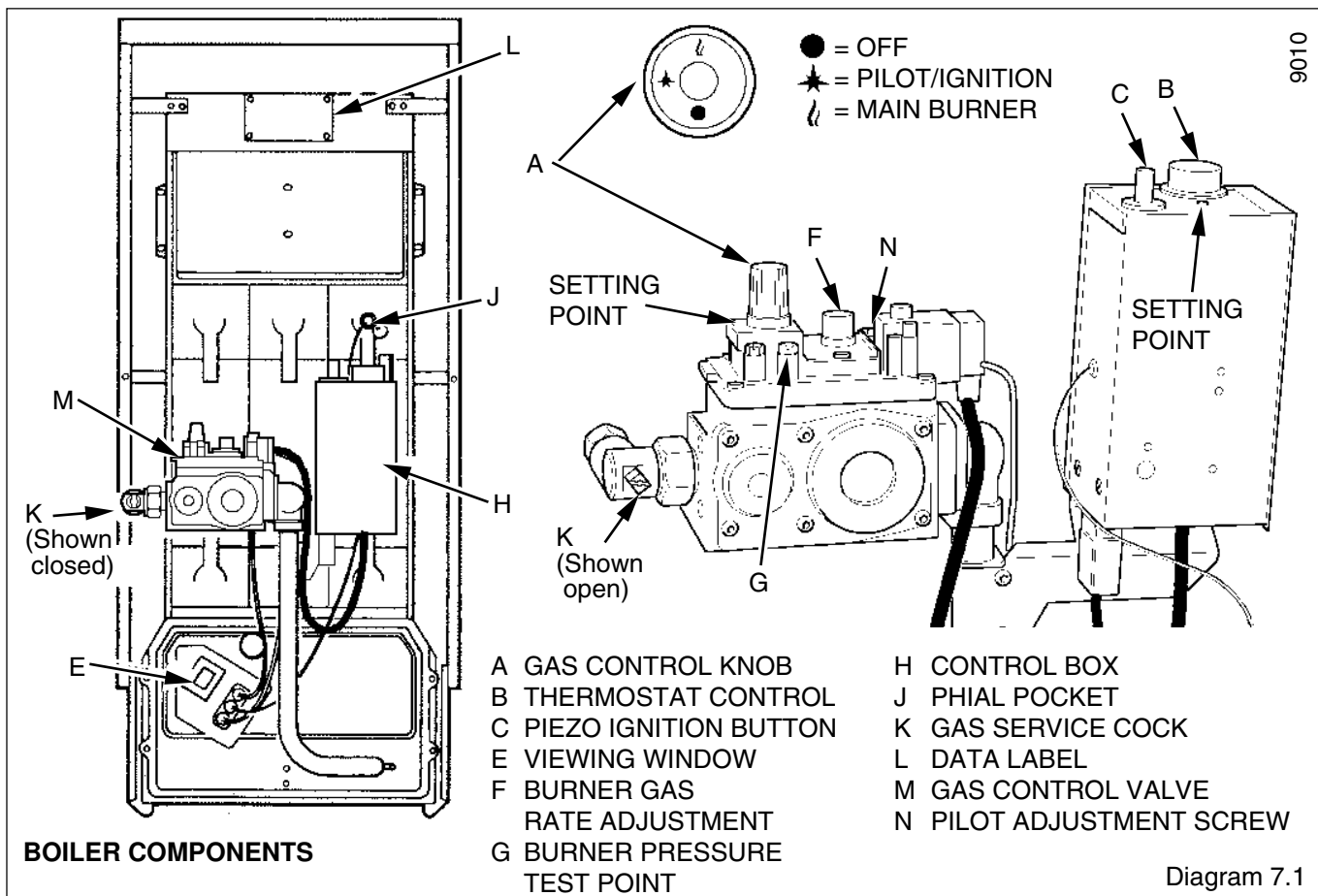

7 Commissioning

7.3 Operational Checks

Check operation of the flame failure device as follows, with the main burner alight, turn the gas valve control knob "A" fully clockwise to its stop ●, this will extinguish the main and pilot burners. The safety device should close before 60 seconds have elapsed, a click from the gas valve will indicate it has closed.

Remove the pressure gauge and refit the pressure test point screw "G", make sure that a gas tight seal is made.

Turn thermostat "B" to "O" then relight the pilot burner as Section 7.1.

Relight the main burner.

Check that the boiler thermostat and all automatic controls are operating correctly.

Do not attempt to adjust the thermostat calibration screw.

Relight the main burner and check for gas soundness with a suitable leak detection fluid.

7.4 Completion and User Information

Instruct and demonstrate the efficient and safe operation of the boiler, heating and hot water system.

Hand the Instructions for Use to the user, for their retention, making sure that they are understood.

Advise that to ensure the continued efficient and safe operation of the boiler it is recommended that it is checked and serviced at regular intervals. The frequency of servicing will depend upon the particular installation and usage, but in general once a year should be enough.

Draw attention, if applicable, to the current issue of the Gas Safety (Installation and Use) Regulations, Section 35, which imposes a duty of care on all persons who let out any property containing a gas appliance.

Fit the plinth front by locating the sides over the boiler plinth then lowering to engage the upper and lower hooks, see diagram 7.3.

Fit the door by locating the hooked runner at the bottom into the slots in the side casings and pushing on to the studs on the side casings.

Reminder - Leave these instructions and the "Benchmark" logbook with the user.

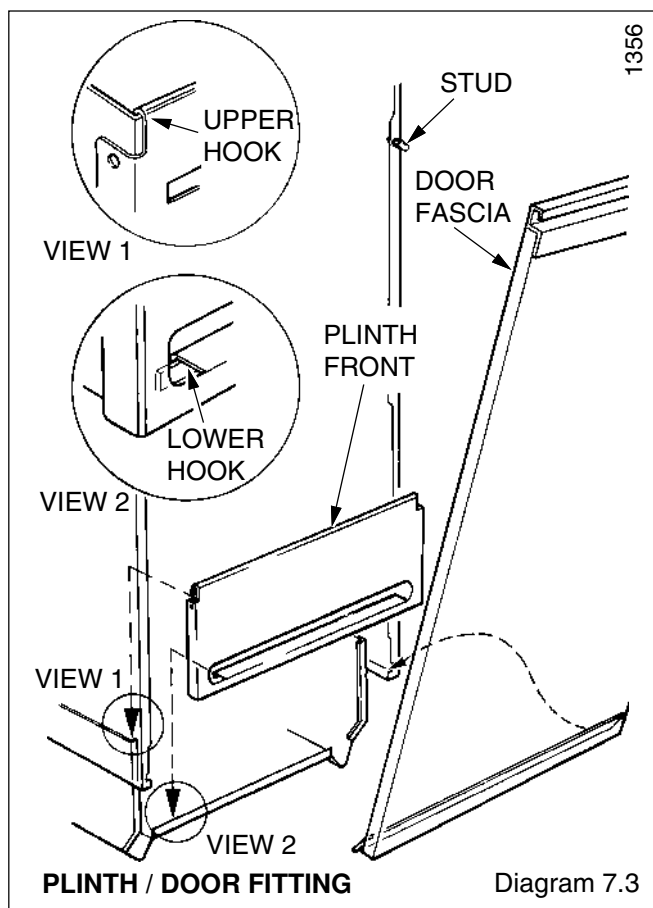
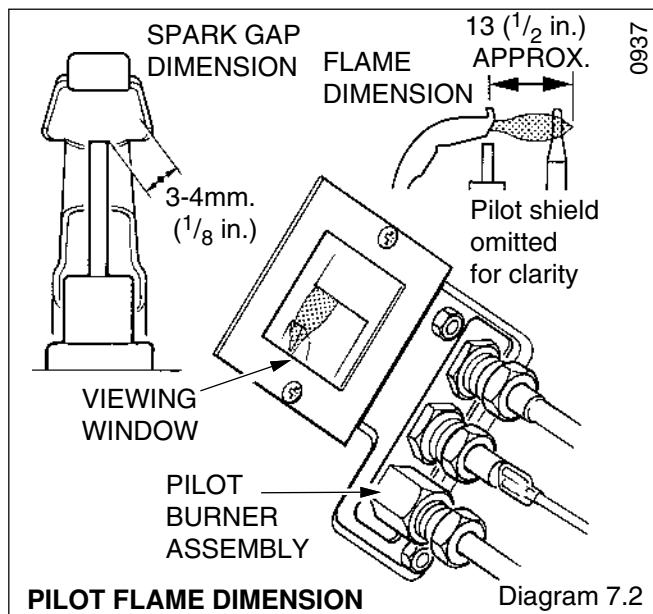

8 Servicing

Servicing must be carried out by a competent person.

Before commencing any servicing, turn off the gas supply at the gas service cock, see diagram 8.1 and isolate the electrical supply to the boiler.

Always test for gas soundness after completing any servicing or replacement of parts.

8.1 Gain Access to the Boiler

Pull the door forwards at the top to disengage studs and lift to release from the slots, see diagram 7.3.

Lift the plinth front up and forwards to withdraw, see diagram 7.3.

If the top casing is removed during servicing care must be taken not to damage or lose any plastic pegs when replacing it. Refer to Section 5.3 "Top Casing" when refitting.

8.2 Boiler Flueways

Unscrew the union nut securing the gas service cock to the gas valve, see diagram 8.1.

Remove the mains inlet connector by pulling downwards, see diagram 8.1.

Remove split pin on the thermostat phial pocket and withdraw the phial and capillary, see diagram 4.5

Remove the four screws retaining the combustion chamber cover and burner assembly, see diagram 8.2.

Ease the gas service cock away from the gas valve and unhook the pipe support bracket from the tie bar to enable the assembly of cover, control box, gas valve and burners to be withdrawn forwards.

Remove graphite coated nut to release baffle tray and remove from combustion chamber, taking care not to damage the insulation material in the sides of the chamber.

Remove the self-tapping screws which retain the flueway cleaning door and lift door clear, see diagram 8.3.

Remove flueway baffles, see diagram 8.6.

Place a sheet of paper in the combustion chamber to catch any flue debris.

Access for flueway cleaning is made through the cleaning door and combustion chamber apertures.

Thoroughly clean boiler flueways and fins from top and bottom with a suitable stiff brush. Remove any debris from the base of the combustion chamber.

Check that the flueways are clear, view with the aid of a mirror or reflector.

8.3 Burner and Injector

Refer to Section 8.2 for instructions on how to remove cover, burners and controls assembly.

Remove the two screws and nuts securing the burner support bracket to the combustion chamber cover, see diagram 8.4.

Remove the graphite coated nuts on supply feed pipe at the rear of the burner to release the burner, taking care not to damage the pilot burner and shield when removing.

Remove the nuts, washers and burner end caps, see diagram 8.5.

Remove the distributor from inside the burner then clean the burner and components thoroughly with a vacuum cleaner.

Check that the main burner injector is not blocked or damaged. Clean or renew as necessary. Do not clean with a wire or sharp instrument, see diagram 8.4.

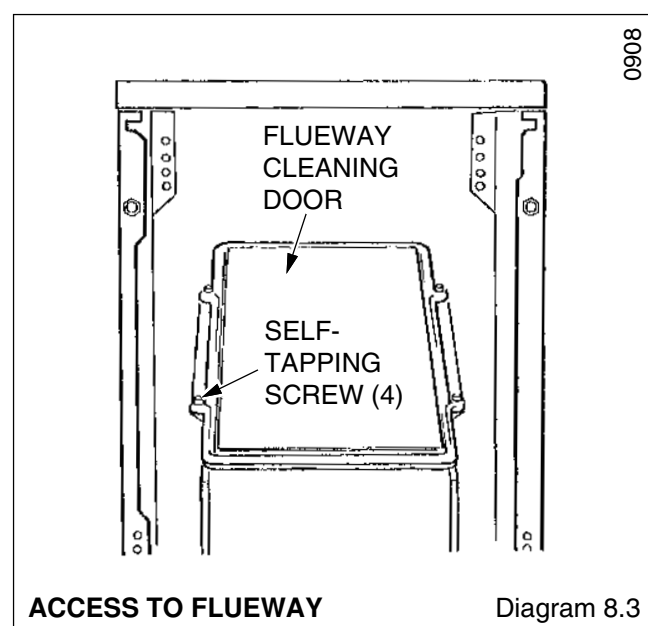
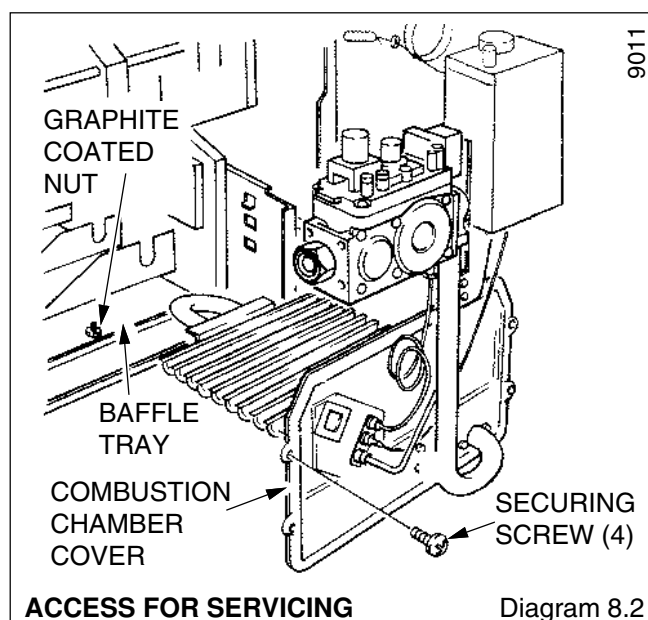
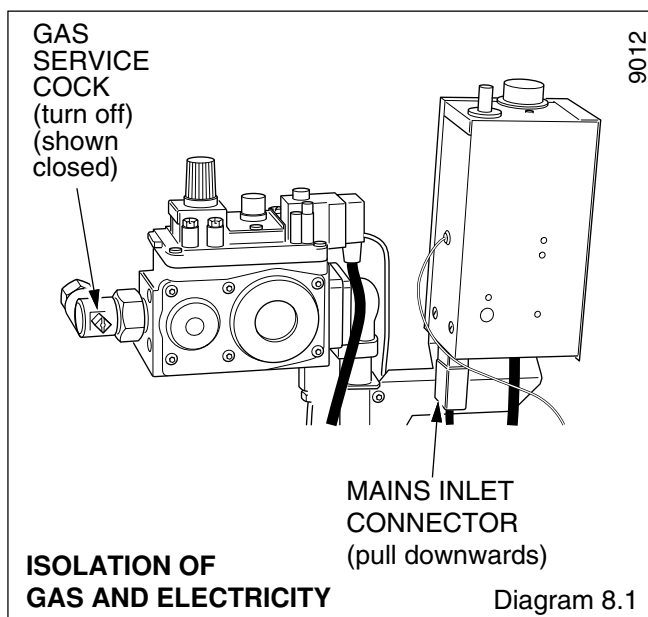

8 Servicing

8.4 Service Checks

Inspect the thermocouple and pilot burner, clean or renew as necessary.

Check the condition of the insulation panels in the combustion chamber, renew if necessary.

Check the condition of the seals on the cleaning door and the combustion chamber cover, renewing if necessary.

8.5 Reassembly

Make sure that the baffle tray is replaced and secured with the graphite coated nuts, previously removed.

Make sure that the thermostat phial is fully inserted into the phial pocket and secured, with the location washer behind the retaining split pin, see diagram 4.5.

Make sure the flueway baffles are positioned as diagram 8.6

8.6 Operational Checks

Light the boiler and carry out the operational checks as described in Sections 7.2 and 7.3.

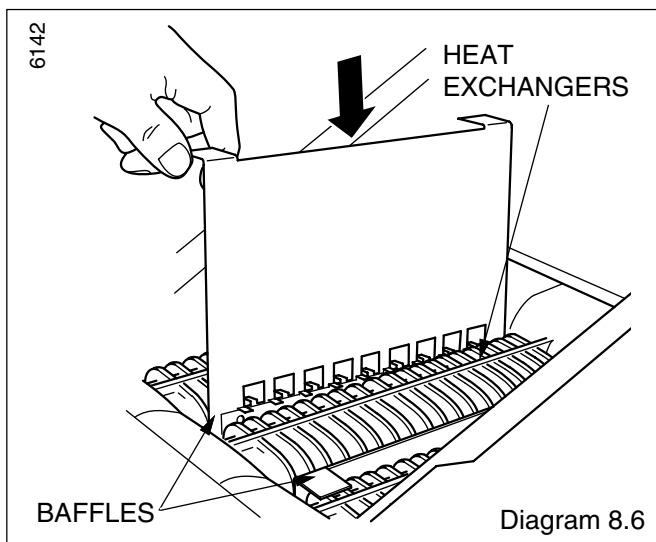
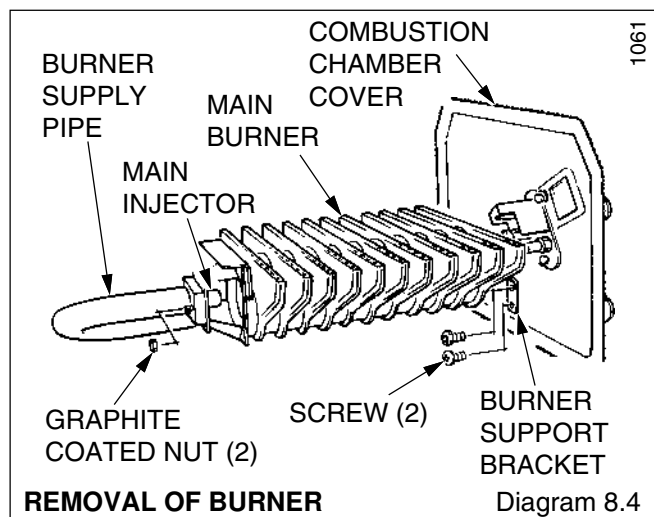
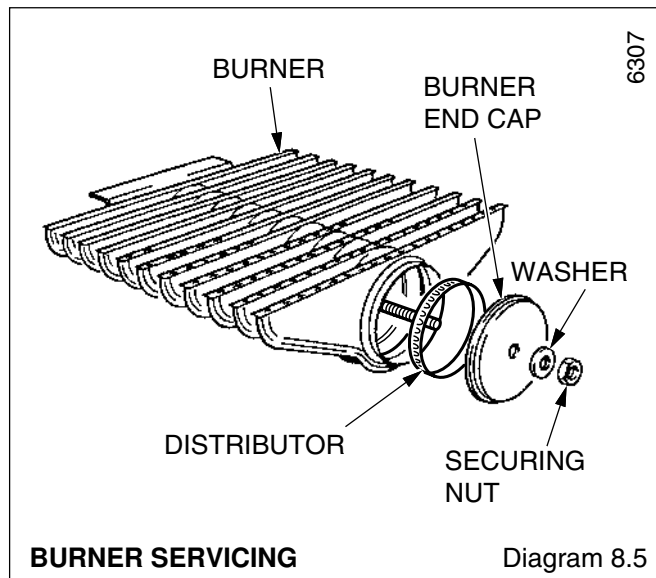

9 Replacement of Parts

Before removing or replacing any parts, turn the gas off at the gas service cock, see diagram 8.1 and isolate the electrical supply to the boiler.

ALWAYS test for gas soundness after replacing any gas carrying component.

Unless stated otherwise, all parts are replaced in the reverse order to removal.

9.1 Gas Valve

Gain access to boiler, see Section 8.1.

Disconnect the gas valve plug, thermocouple nut and pilot tube connections at the gas valve, see diagram 9.1.

Support the valve and remove the four right-hand flange screws to disconnect the gas valve from the burner supply pipe.

Ease the gas service cock union out and remove the valve taking care not to damage the "O" ring seal at the flange.

Inspect the condition of the "O" ring seal and renew if necessary.

Remove the union half and refit into the replacement valve on the inlet, left-hand side. Use a little jointing compound, on the external thread only, to ensure gas soundness.

It will be necessary to purge air from the gas line after changing the gas valve, refer to Section 7.2.

9.2 Injector

Gain access to the boiler as Section 8.1.

Unscrew the injector from the manifold and renew as necessary.

When replacing the injector use a little jointing compound, on the external thread only, to ensure gas soundness.

Replace thermostat phial as Section 8.5.

9.3 Thermocouple

Gain access to the boiler as Section 8.1.

Disconnect the thermocouple by unscrewing nuts at the gas valve and pilot burner, see diagram 9.1 and 9.2. Withdraw the thermocouple.

When replacing tighten the thermocouple nut only a quarter turn beyond finger tight.

9.4 Pilot Burner

Gain access to the boiler as Section 8.1.

Remove the cover and burner controls assembly, as Section 8.2.

Disconnect the ignition lead at the electrode, see diagram 9.2.

Disconnect the thermocouple nut at the pilot burner.

9 Replacement of Parts

Disconnect the pilot tube nut, ease out the tube and injector which is hooked on to the pilot tube.

Remove the nut retaining the spark electrode and remove.

Remove the two screws and nuts securing the pilot burner and shield to the combustion chamber cover.

When fitting the spark electrode to the pilot burner, check that the gap is as shown in diagram 7.2.

Hook pilot injector over pilot tube olive when refitting.

Check that the pilot flame length is as shown in diagram 7.2.

Replace thermostat phial as Section 8.5.

9.5 Spark Electrode

Gain access to the boiler as Section 8.1.

Disconnect the thermocouple nut and withdraw thermocouple from pilot burner, see diagram 9.2.

Disconnect the nut retaining the spark electrode and remove.

When reassembling check that spark gap is as shown in diagram 7.2.

9.6 Insulation Panels

Gain access to the boiler as Section 8.1.

Remove the burner assembly as Section 8.2.

Remove the two screws retaining each side insulation panel within the combustion chamber and remove panel, see diagram 9.3.

Release the rear insulation panel upper clips and lift panel out.

Refit thermostat phial as Section 8.5.

9.7 Boiler Thermostat

Follow the relevant instructions in Section 8.1.

Remove the mains inlet connector by pulling downwards, see diagram 8.1.

Remove the retaining split pin from the phial pocket then withdraw the phial and capillary, see diagram 4.5.

Pull off the thermostat control knob.

Gain access to inside of the control box by removing the securing screw located at the top of control box and unhooking at the bottom, see diagram 9.4.

Remove the two screws which secure the boiler thermostat to the control box, see diagram 9.4.

Tilt the thermostat so that the electrical connections can be removed.

Withdraw boiler thermostat from control box complete with capillary tube and phial.

Refer to diagram 9.5 to connect electrical connectors.

Replace the thermostat phial as the relevant part of Section 8.5.

Make sure that the capillary is positioned so that it passes through the cut out in the control box, see diagram 9.4.

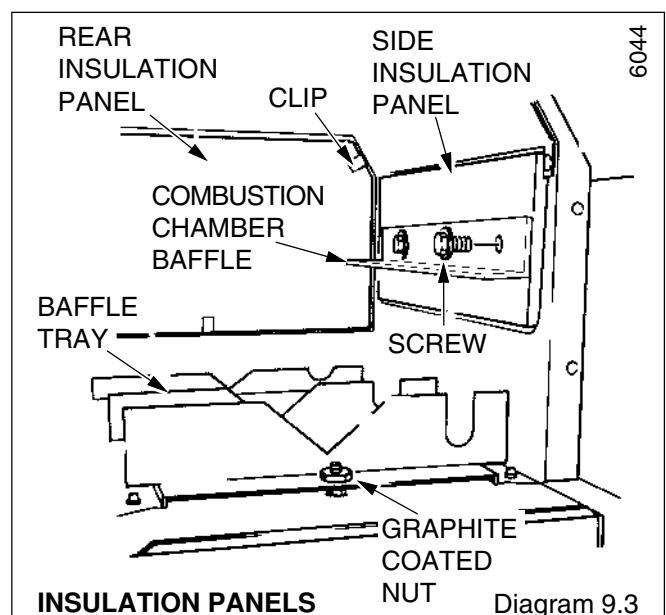
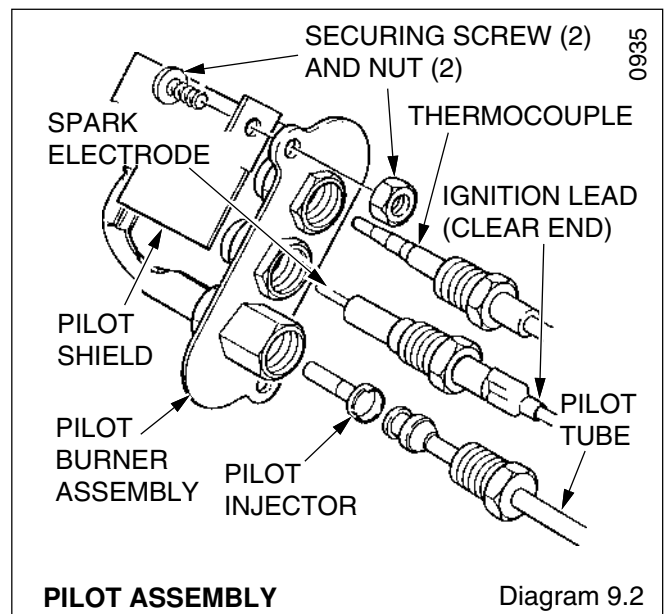
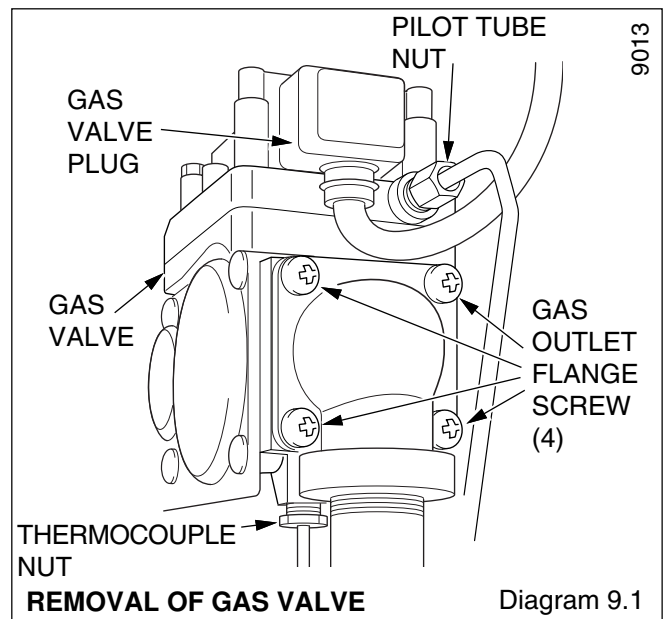

9 Replacement of Parts

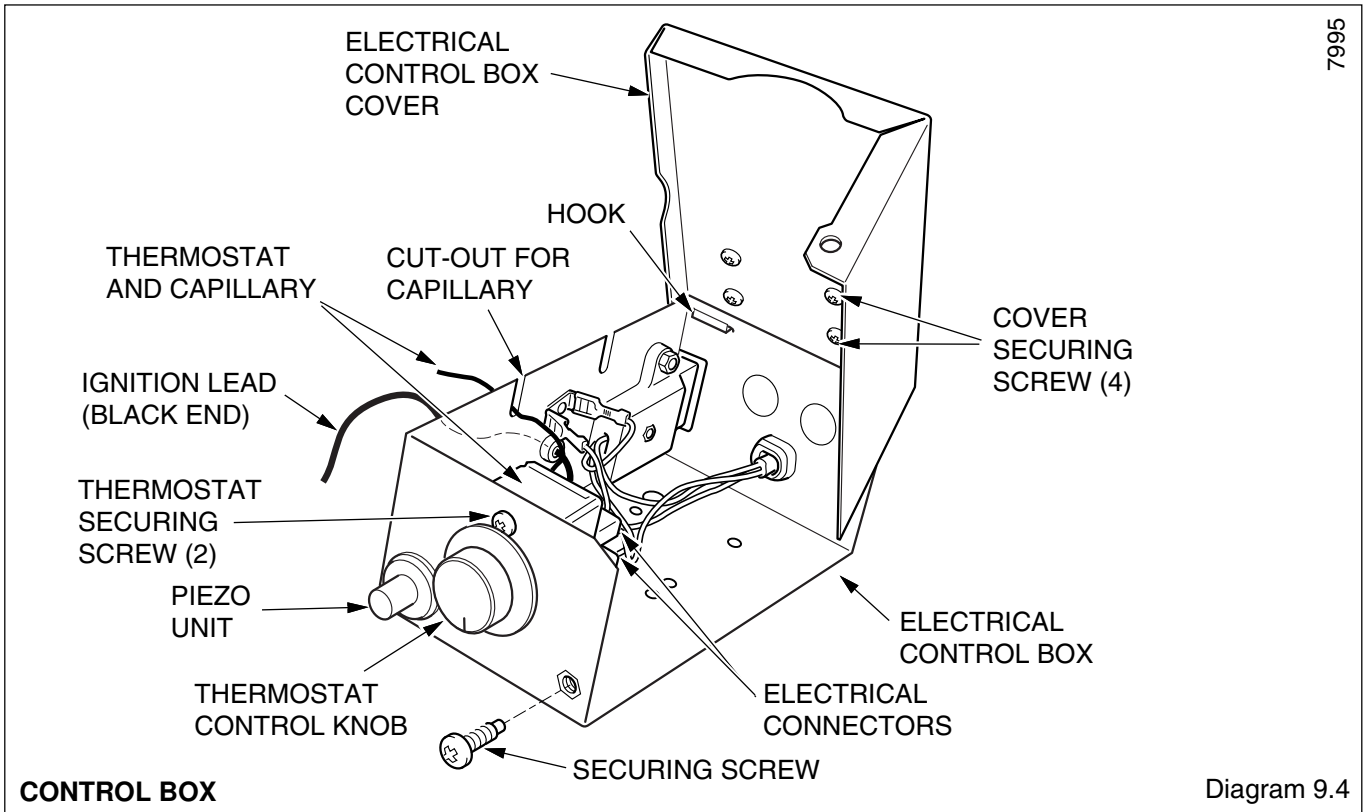

9.8 Piezo Unit

Pull door forward at the top to disengage the studs and lift to release from slots, see diagram 7.3.

Remove mains inlet connector by pulling downwards, see diagram 8.1.

Gain access to inside of the control box by removing the securing screw located at the top of control box and unhooking at the bottom, see diagram 9.4.

Disconnect the ignition lead at the piezo unit.

Note: To ease the removal of the piezo unit it is advisable to temporarily remove the boiler thermostat from the control box.

Depress the retaining tabs and remove the Piezo unit.

9.9 Ignition Lead

Gain access to the boiler as Section 8.1.

Disconnect the ignition lead at the piezo unit, see diagram 9.4 and section 9.8.

Disconnect the lead at the spark electrode, see diagram 9.2.

When reconnecting lead make sure that the clear end is fitted to the spark electrode.

9.10 Electrical Control Box

Gain access to the boiler as Section 8.1.

Disconnect the mains inlet connector, see diagram 8.1.

Remove the thermostat phial by removing the retaining split pin from the phial pocket and withdrawing the phial, see diagram 4.5.

Disconnect the gas valve plug from the valve, see diagram 9.1.

Pull the ignition lead off at the piezo unit, see diagram 9.4.

Remove the electrical control box cover securing screw and unhook the cover at the side.

Remove the two screws and nuts to release the box from the support bracket.

Refit the thermostat phial as Section 8.5.

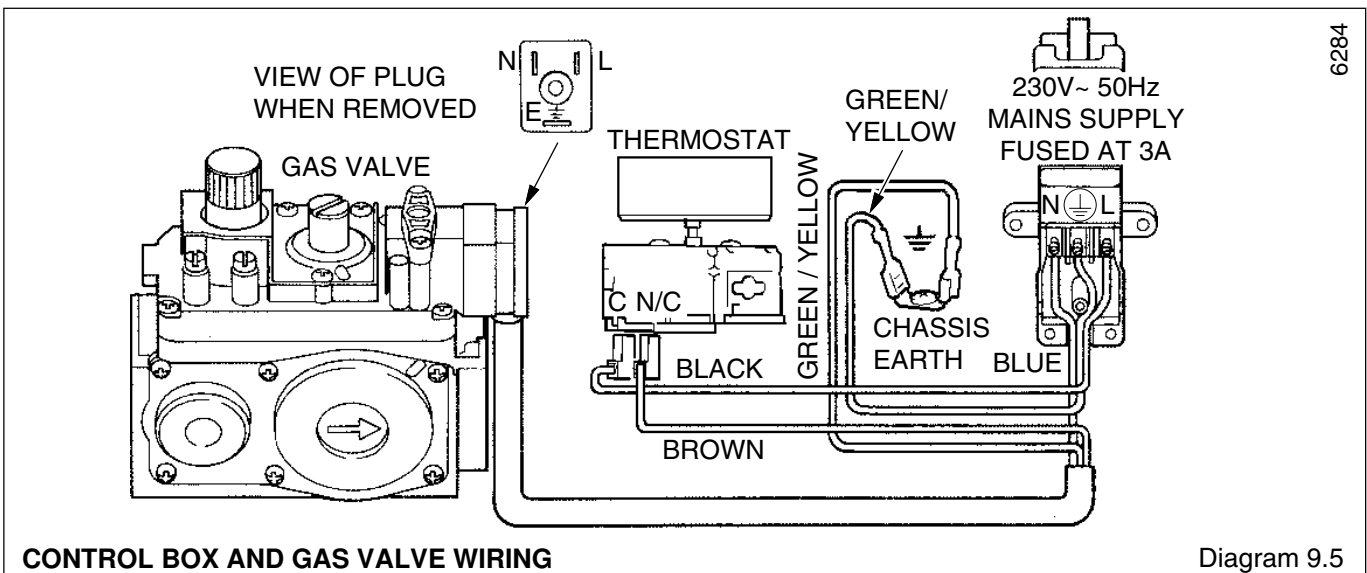

10 Fault Finding - Electrical

10.1 Electrical

IMPORTANT, the preliminary electrical system checks as contained in the British Gas Multimeter Instruction book or similar publication, are the first checks to be carried out during a fault finding procedure. On completion of the service fault finding task which has required the breaking and remaking of electrical connections then checks, earth continuity, polarity and resistance to earth must be repeated.

Refer to functional flow diagram 10.1 electrical fault finding chart, diagram 10.2 and wiring diagram 9.5

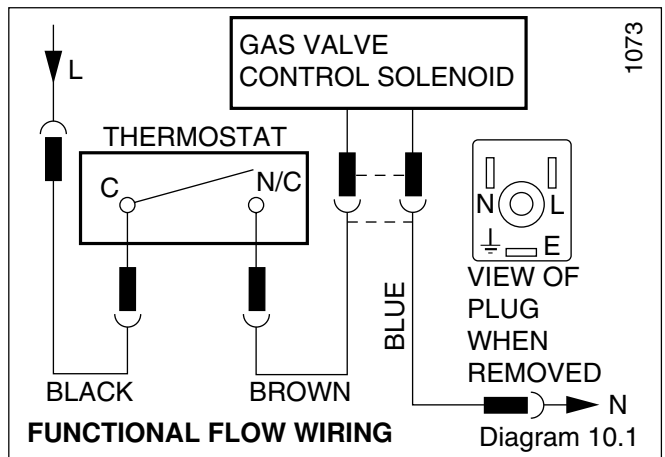

1073

Carry out preliminary electrical system checks to make sure that the electricity supply is available at the boiler. Check that any remote time or temperature controls are calling for duty. Make sure that the system is filled, the gas supply is available and the pilot is lit.

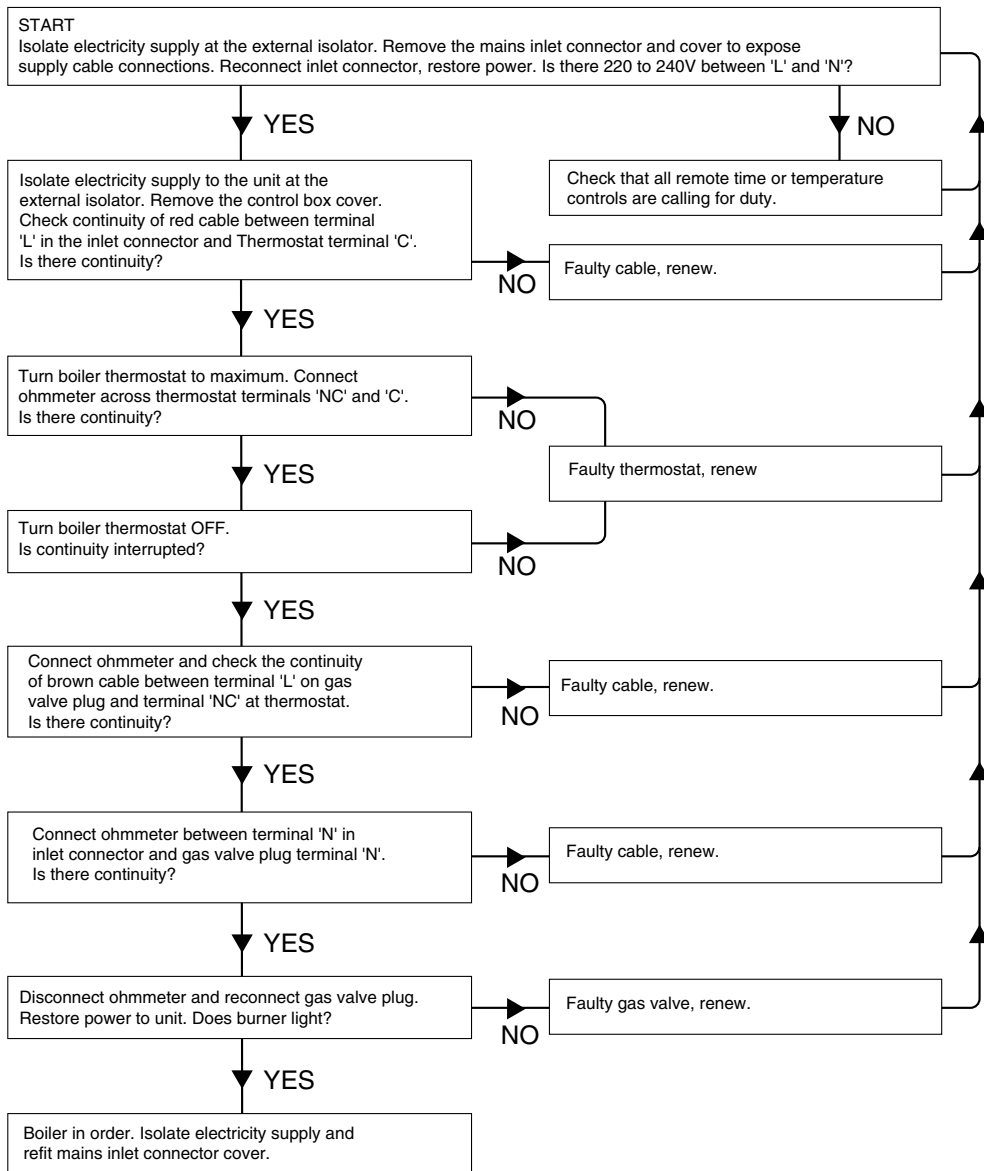

1526

ELECTRICAL FAULT FINDING

Diagram 10.2

10 Fault Finding - Thermocouple

6042

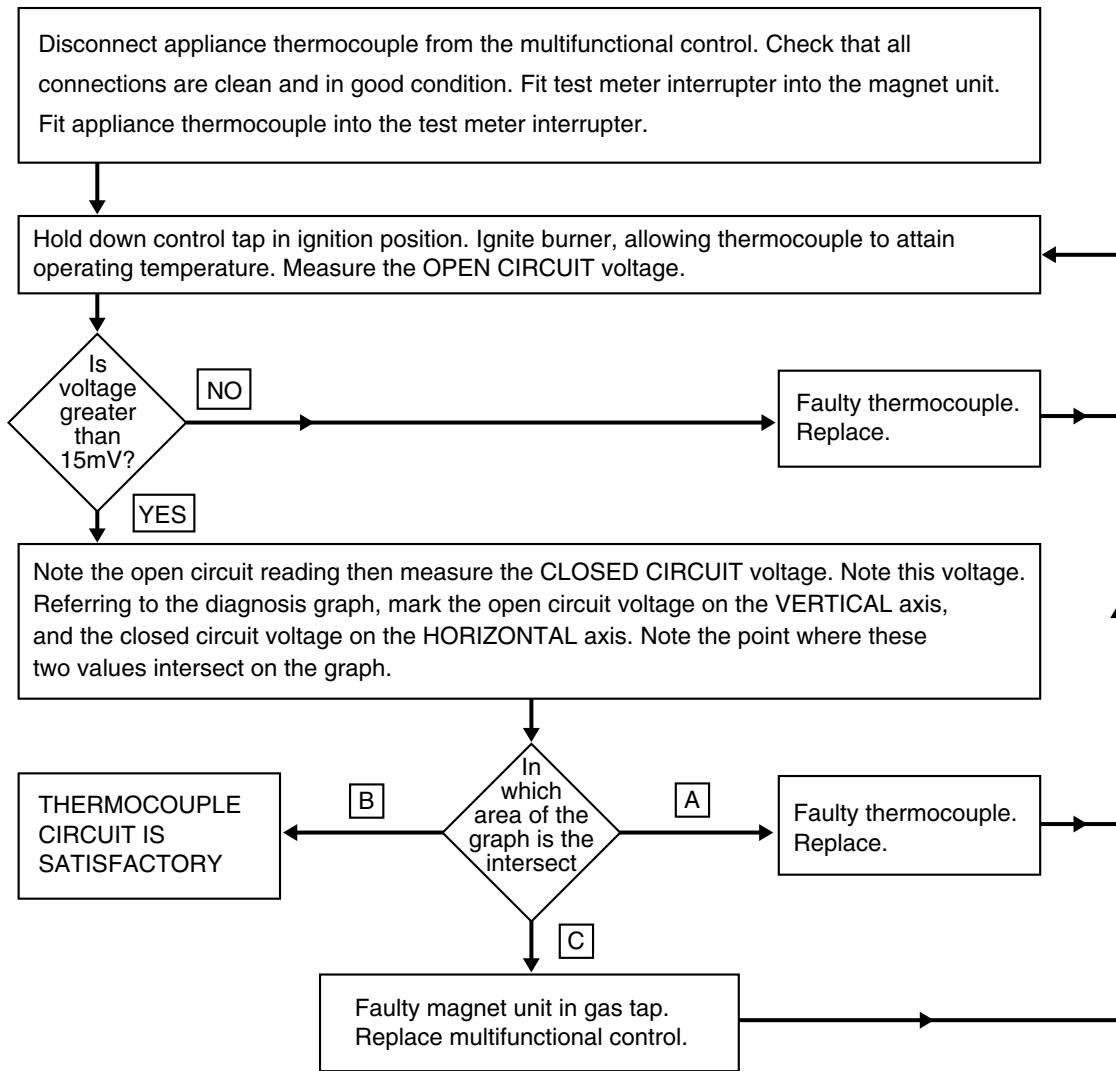

THERMOCOUPLE FAULT FINDING

Diagram 10.3

10.2 Thermocouple

To test the thermocouple a meter with a range of 0 to 30mV is required together with a thermocouple interrupter similar to the Minitest 6 Multimeter and interrupter.

Refer to thermocouple fault finding chart, diagram 10.3 and diagnosis graph, diagram 10.4.

10.3 Pilot

Refer to pilot fault finding chart, diagram 10.5.

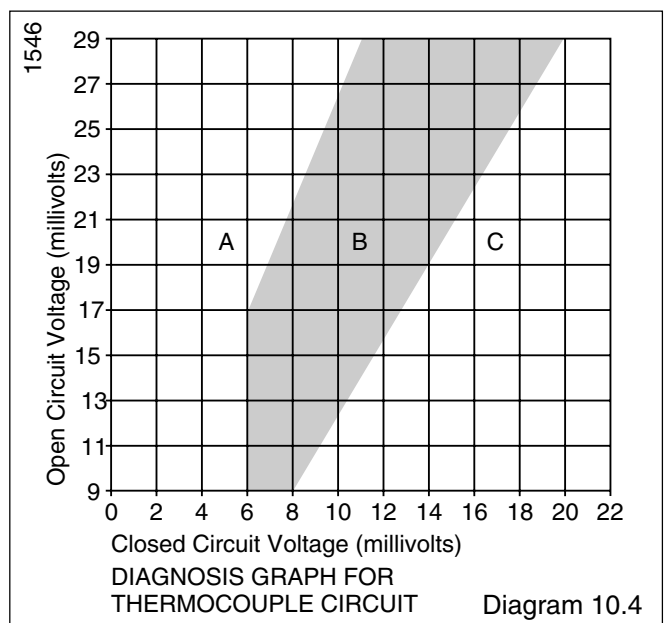
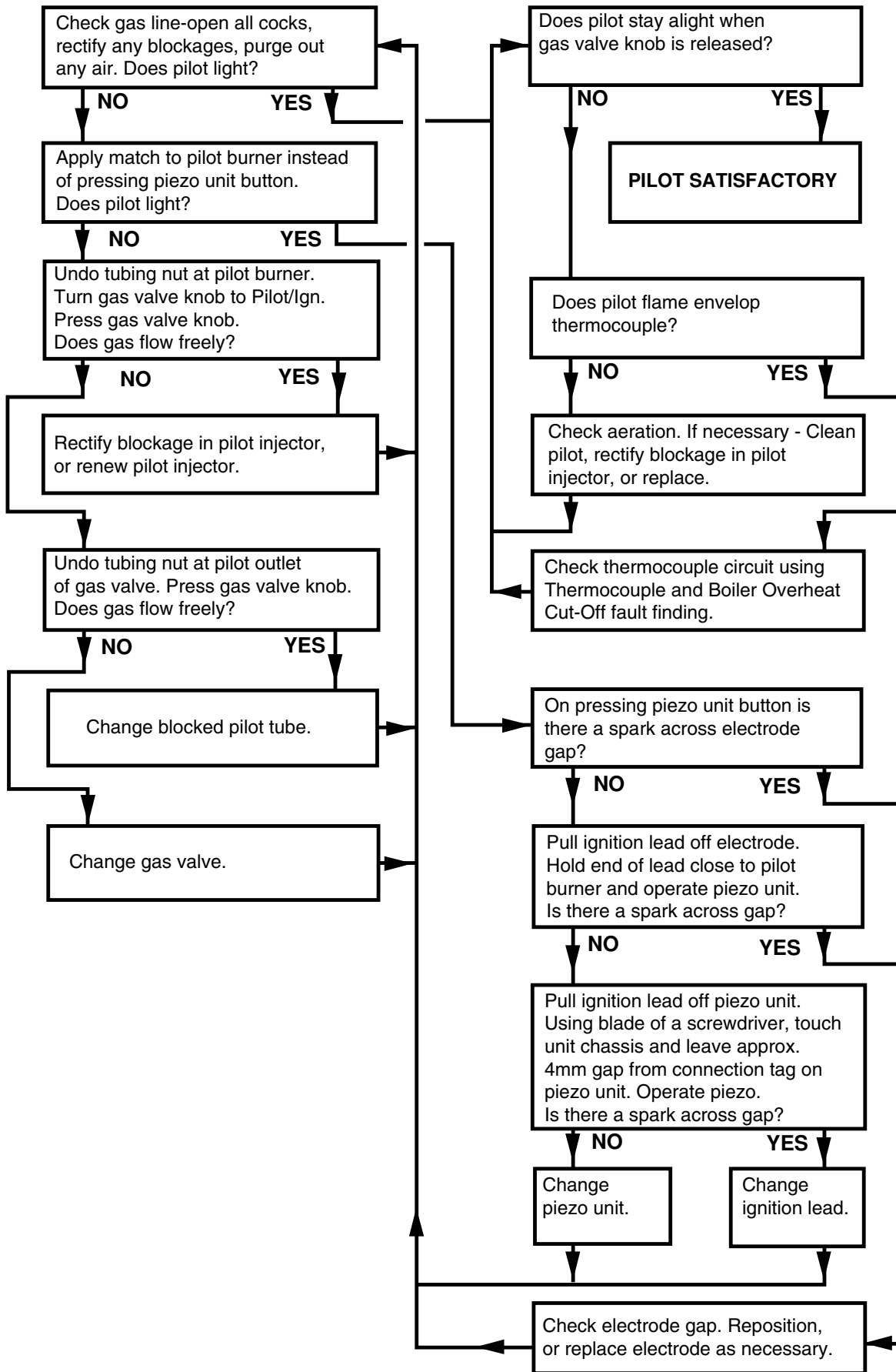

Diagram 10.4

**PILOT WILL NOT LIGHT
START HERE**



BOILER PILOT FAULT FINDING

Diagram 10.5

11 Spare Parts

When ordering spare parts please quote the part number and description, stating the model and serial number, from the data label "L", see diagram 7.1.

If ordering from British Gas also quote the GC number of the part and appliance.

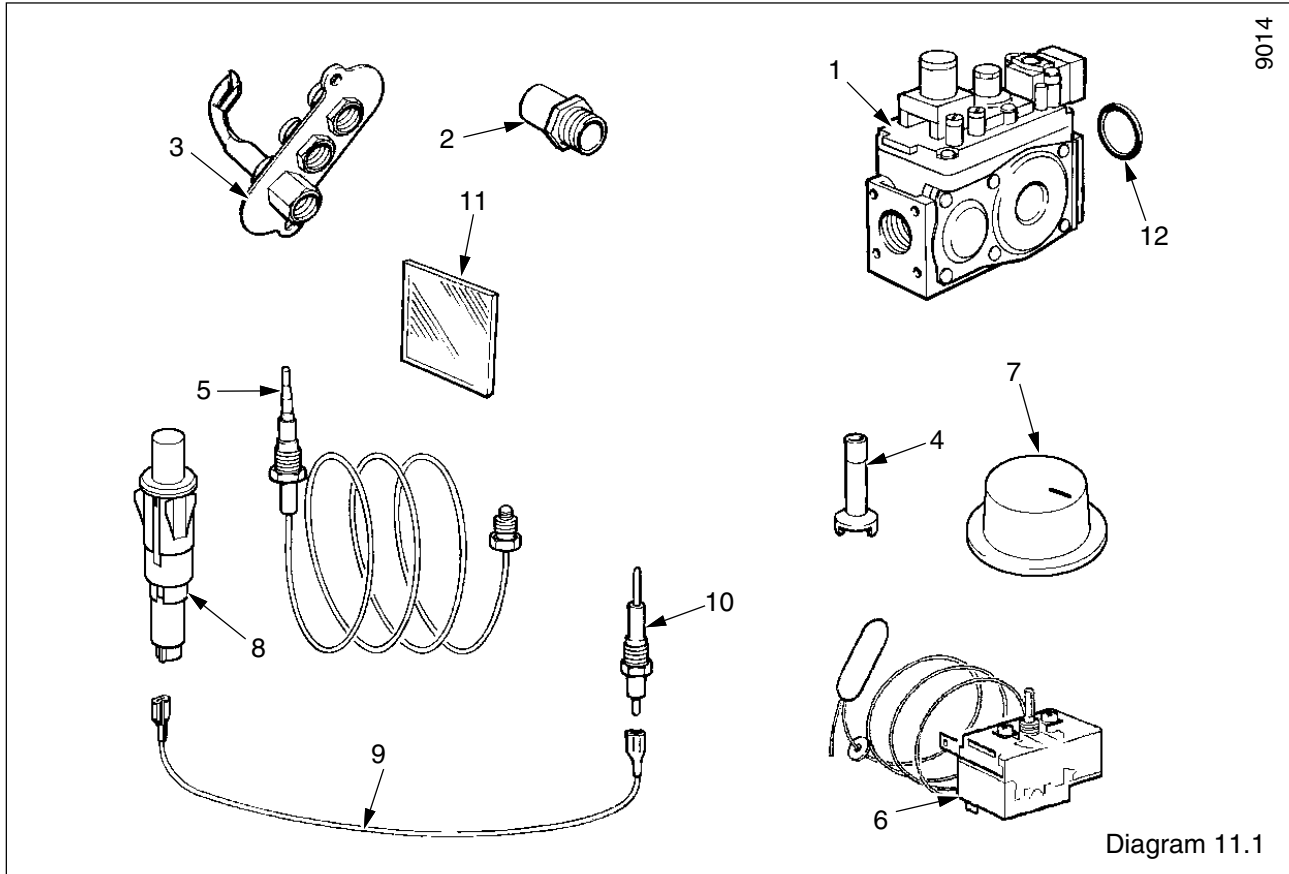

9014

Diagram 11.1

Key No	Part No	Description	GC No
1	800001	Gas control valve	*** **
2	205749	Injector	*** **
3	203414	Pilot burner	312 426
4	203508	Injector - pilot	395 674
5	202407	Thermocouple c/w nut	392 850
5	202415	Thermocouple c/w nut	
6	202571	Thermostat c/w screws	
7	204687	Control knob assy - thermostat	
8	202713	Piezo unit	
9	WW4609	Ignition lead assembly	136 464
10	202605	Spark electrode	395 720
11	208302	Sight glass	312 419
12	212031	"O" ring - gas valve	312 602

Because of our constant endeavour for improvement, details may vary slightly from those shown in these instructions.