

Instructions for Use Installation and Servicing

To be left with the user

Hideaway 60B

G.C. No. 41 313 12

Balanced Flue Boiler



This is a Cat I_{2H} Appliance

Reference in these instructions to British Standards and Statutory Regulations/Requirements apply only to the United Kingdom. For Ireland the rules in force must be used.

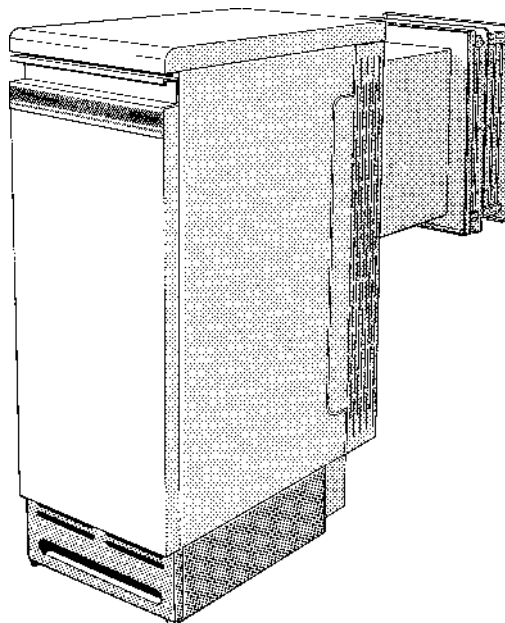

0863

The instructions consist of three parts, User, Installation and Servicing Instructions, which includes the Guarantee Registration Card. The instructions are an integral part of the appliance and must, to comply with the current issue of the Gas Safety (Installation and Use) Regulations, be handed to the user on completion of the installation.

Guarantee Registration

Thank you for installing a new Glow-worm appliance in your home.

Glow-worm appliances' are manufactured to the very highest standard so we are pleased to offer our customers' a Comprehensive First Year Guarantee.

In the centre pages are to be found your Guarantee Registration Card, which we recommend you complete and return as soon as possible.

If this card is missing you can obtain a copy or record your registration by telephoning the Heatcall Customer Service number 01773 828100.

Our Guarantee gives you peace of mind plus valuable protection against breakdown by covering the cost of:

- All replacement parts**
- All labour charges**
- All call-out charges**

REGISTER YOUR GLOW-WORM APPLIANCE
FOR 1ST YEAR GUARANTEE PROTECTION

CALL 0208 247 9857

HEATCALL

Customer Services:

Tel: (01773) 828100

One Contact Local Service Fax: (01773) 828070

Hepworth Heating Ltd.,

Nottingham Road, Belper, Derbyshire. DE56 1JT

General/Sales enquiries:

Tel: (01773) 824141 Fax: (01773) 820569

Important Information

Testing and Certification

This boiler is tested and certificated for safety and performance. It is therefore important that no alteration is made to the boiler, without permission, in writing, from Hepworth Heating Ltd.

Any alteration not approved by Hepworth Heating Ltd., could invalidate the certification, boiler warranty and may also infringe the current issue of the Statutory Requirements, see Section 1.3.

CE Mark

This boiler meets the requirements of Statutory Instrument No. 3083 The boiler (Efficiency) Regulations, and therefore is deemed to meet the requirements of Directive 92/42/EEC on the efficiency requirements for new hot water boilers fired with liquid or gaseous fuels.

Type test for purposes of Regulation 5 certified by: Notified body 0086.

Product/productioncertifiedby: Notified body 0086.

The CE mark on this appliance shows compliance with:

1. Directive 90/396/EEC on the approximation of the laws of the Member States relating to appliances burning gaseous fuels.
2. Directive 73/23/EEC on the harmonization of the Laws of the Member States relating to the electrical equipment designed for use within certain voltage limits.
3. Directive 89/336/EEC on the approximation of the Laws of the Member States relating to electromagnetic compatibility.

INFORMATION FOR THE INSTALLER AND SERVICE ENGINEER.

Under Section 6 of The Health and Safety at Work Act 1974, we are required to provide information on substances hazardous to health.

CERAMIC FIBRE/INSULATION PADS, GLASSYARN.

These can cause irritation to skin, eyes and the respiratory tract. If you have a history of skin complaint you may be susceptible to irritation. High dust levels are usual only if the material is broken. Normal handling should not cause discomfort, but follow normal good hygiene and wash your hands before eating, drinking or going to the lavatory. If you do suffer irritation of the eyes or severe irritation to the skin seek medical attention.

THERMOSTATS

These contain very small amounts of xylene in the sealed phial and capillary. If broken, under normal circumstances the fluid does not cause a problem, but in case of skin contact, wash with cold water. If swallowed drink plenty of water and seek medical attention.

CONTENTS	DESCRIPTION	SECTION	PAGE No.
INSTRUCTIONS FOR USE	Introduction		3
	Lighting the Boiler		4
INSTALLATION INSTRUCTIONS	General Data	1	5
	Water Systems	2	7
	Flue and Ventilation	3	8
	Installation	4	10
	Casing Location / Fitting	5	12
	Electrical Wiring	6	14
	Commissioning	7	15
SERVICING INSTRUCTIONS	Servicing	8	17
	Replacement Parts	9	19
	Fault Finding	10	21
	Spare Parts	11	24

Instructions for Use

Notes and General Information

Please read these instructions and follow them carefully for the safe and economical use of your boiler.

The boiler is automatic in operation, once the pilot has been lit and the controls set.

Glow-worm Hideaways are central heating boilers, to provide heating and if required, an indirect domestic hot water supply.

Gas Safety (Installation and Use) Regulations

In your own interests and that of safety, it is the law that ALL gas appliances are installed by a competent person in accordance with the current issue of the above regulations.

Warning

Make sure that nothing obstructs the rear side grille or clearances. See page 4 for minimum clearances.

Boilers Installed in a Compartment

If the boiler is fitted in a compartment, cupboard etc., do not obstruct the purpose built compartment vents or the grille on the boiler.

Do not use the compartment for storage purposes.

Maintenance

To ensure the continued efficient and safe operation of the boiler it is recommended that it is checked and serviced as necessary at regular intervals. The frequency of servicing will depend upon the particular installation conditions and usage, but in general once a year should be enough.

It is the law that servicing must be carried out by a competent person.

If this appliance is installed in a rented property there is a duty of care imposed on the owner of the property by the current issue of the Gas Safety (Installation and Use) Regulations, Section 35.

To obtain service please call your installer or Heatcall (Glow-worm's own service organisation) using the telephone number given on the inside of the front panel.

Please be advised that the 'Benchmark' logbook should be completed by the installation engineer on completion of commissioning and servicing.

All CORGI Registered Installers carry a CORGI ID card, and have a registration number. Both should be recorded in your boiler Logbook. You can check your installer is CORGI registered by calling CORGI direct on :- 01256 372300.

Boiler Electrical Supply

WARNING. This boiler must be earthed.

The boiler must only be connected to a 240V~50Hz supply protected by a 3A fuse, maximum.

All wiring must be in accordance with the current issue of BS7671.

Heat resistant flexible cable having a conductor size of 0.75mm², to the current issue of BS6500 Table 16 must be used.

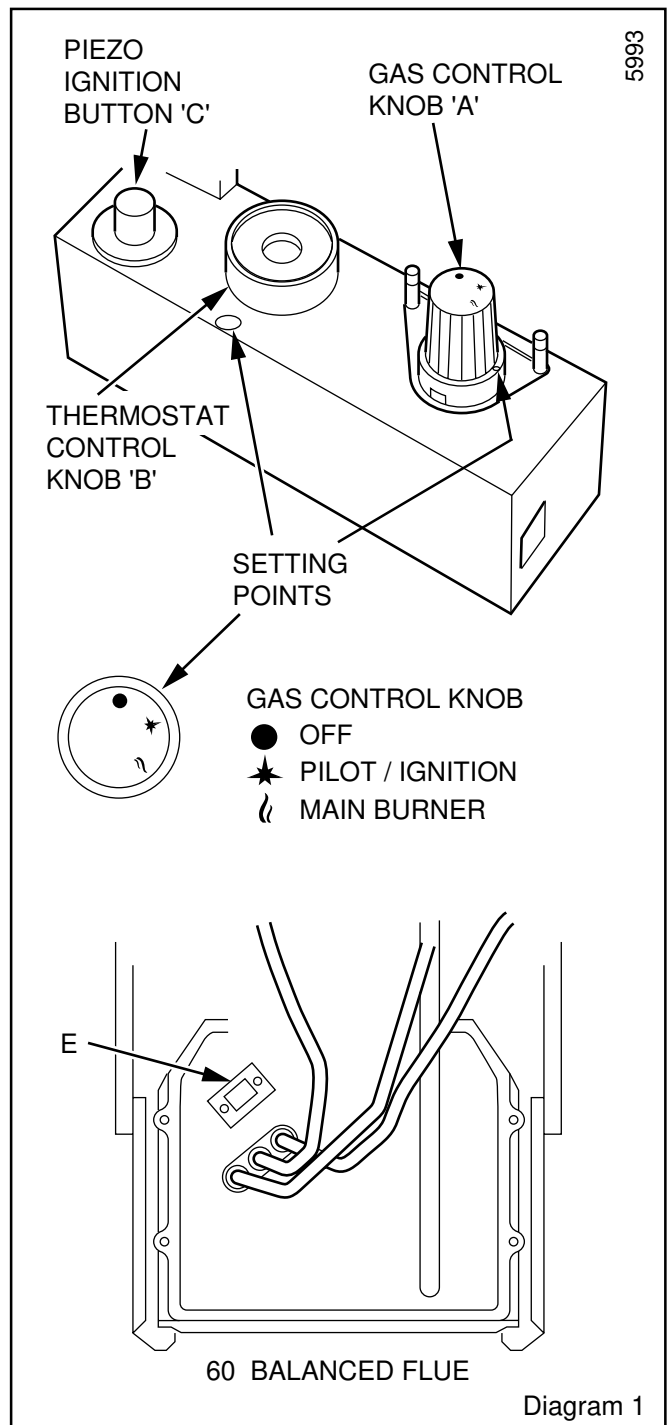

Instructions for Use

To Connect an Electrical Plug

The standard colours of three core flexible cable are,
Brown - live, Blue - neutral, Green and Yellow - earth.

As the markings on your plug may not correspond with these colours, continue as follows:

The Blue cable must be connected to the terminal marked "N" or "Black".

The Brown cable must be connected to the terminal marked "L" or "Red".

The Green and yellow cable must be connected to the terminal marked "E" or "Green" or the earth symbol .

To Light the Boiler

WARNING. If the pilot light goes out for any reason, do not attempt to relight until 3 minutes have elapsed.

Remove the door by pulling forwards with the fascia at the top. Lift up to disengage from the bottom side lugs.

Refer to diagram 1 to identify controls.

Check that the mains electrical supply to the boiler is switched OFF.

Push in slightly and turn gas control knob "A" clockwise until  is against its setting point.

Turn thermostat control knob "B" anticlockwise until "O" is against its setting point.

Push in slightly and turn gas control knob "A" anticlockwise until  is against its setting point, then depress fully and hold in.

Push in and release piezo ignition button "C" until the pilot burner lights.

Air may be present in the supply pipe so the lighting of the pilot may need to be repeated until all the air has been expelled.

When the pilot is alight, view through window "E", keep gas control knob "A" fully pushed in for about 15 seconds, then release.

If the burner fails to stay alight, wait 3 minutes, then repeat the lighting procedure only now keep control knob "A" pushed in for a little longer before releasing.

Press in and turn gas control knob "A" anticlockwise until  is against its setting point.

If the gas control knob "A" is turned to  a safety lock prevents it being turned on again for a short period. No attempt should be made to relight the pilot until 3 minutes have elapsed.

Make sure that the pilot is alight and stable then switch on the electrical supply.

Set any system controls to "ON" or "HIGH".

Turn the boiler thermostat knob "B" clockwise until "MAX" is against its setting point and the main burner will light. Adjust thermostat to required setting between "MIN" and "MAX". "MAX" is about 82°C (180°F).

Refit the door by locating the hooked runner at the bottom into the slot in the side panels and pushing onto the studs.

To Turn the Boiler Off

For short periods, turn the boiler thermostat control knob "B" anticlockwise to "O". The pilot will stay alight. To relight the main burner turn thermostat control knob "B" clockwise to the desired setting between "MIN" and "MAX".

For longer periods, depress slightly and turn gas control knob "A" fully clockwise until  is against its setting point. Turn thermostat control knob "B" anticlockwise to "O". Isolate the boiler from the electrical supply. Follow full lighting procedure to relight. Refer also to "Protection Against Freezing".

Gas Leak or Fault

If a gas leak fault exists or is suspected the boiler must be turned off, including the electrical supply and must not be used until the fault has been put right. Advice/help should be obtained from the local gas undertaking or your installation/servicing company.

Protection Against Freezing

If the boiler is to be out of use for any period of time during severe weather conditions we recommend the whole system including the boiler, be drained off to avoid the risk of freezing up. If an immersion heater is fitted to the hot water cylinder make sure it is switched off.

Sheet Metal Parts

WARNING. This boiler contains metal parts (components) and care should be taken when handling and cleaning, with particular regard to edges.

Cleaning

Keep the casing clean by wiping it occasionally with a damp soapy cloth and dry with a polishing cloth.

Do not use abrasive cleaners.

Replacement Parts/Boiler Identification

If replacement parts are required apply to your local supplier. Please quote the name of the boiler and its serial number which can be found on the data label, positioned on the boiler top, to the rear of the inclined flueway cleaning door.

Clearances

Minimum clearances must be left around the boiler as shown in diagrams 1.3, 1.4 & 1.5.

General Data

* Refer to BOILER CASING HEIGHT diagram

† A SPECIAL TOP CASING TO SUIT 600mm (23⁵/₈ in.) WORKTOPS IS AVAILABLE

⌋ GAS CONNECTION
Rc 1/2 (1/2 in. B.S.P.T.)

⊙ WATER CONNECTIONS
Rc1 (1in. B.S.P.T.)

⊙ WATER CONNECTIONS Rc1 reduced with DISTRIBUTOR TUBE to Rc 3/4 (3/4 in. B.S.P.T.) (pumped return)

0684

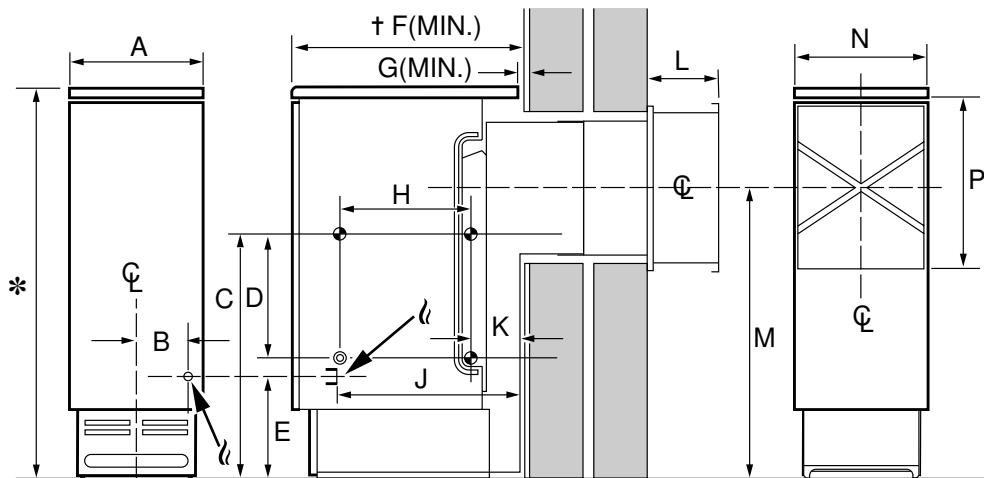

GENERAL DIMENSIONS - given in millimetres (Approx. inches)

Diagram 1.1

	A	B	C	D	E	†F	G	H	J	K	L	M	N	P
mm	300	118	558	294	225	533	3	300	445	121	156	664	292	398
in.	11 ³ / ₄	4 ⁵ / ₈	22	11 ¹ / ₂	8 ⁷ / ₈	21	1/8	11 ³ / ₄	17 ¹ / ₂	4 ³ / ₄	6 ¹ / ₈	26 ¹ / ₈	11 ¹ / ₂	15 ⁵ / ₈

Sheet Metal Parts

WARNING. When installing or servicing this boiler, care should be taken to avoid any possibility of personal injury when handling the edges of sheet metal parts.

Important Notice

This boiler is for use only on G20 gas.

Wherever possible, all materials, appliances and components used shall comply with the requirements of applicable British Standards.

Where no British Standard exists, materials and equipment should be fit for their purpose and of suitable quality and workmanship.

1.1 Data

Approximate weight of complete boiler : 79kg (174lb)

Water content : 5.76 litre (1.27gallons)

Gas connection : Rc1/2 (1/2 in BSPT)

Water connection : Rc1 (1in BSPT)

Injector : 3.9mm

Electrical supply : 240V~50Hz, fused 3A

Burner : Aeromatic

All dimensions are given in millimetres (except as noted).

The Seasonal Efficiency Domestic Boilers UK (SEDBUK) is 71.7%.

The value is used in the UK Government's Standard Assessment Procedure (SAP) for energy rating of dwellings. The test data from which it has been calculated have been certified by B.S.I.

1.2 Range Rating

This boiler is range rated and may be adjusted to suit individual system requirements. The table gives settings and outputs.

The boiler input as supplied is preset to the maximum heat input and should be adjusted to suit system requirements.

The indicator arrow should be stuck on the data label to indicate the adjusted setting. The arrow is supplied in the loose items pack.

RANGE RATING		min	medium	max
NOMINAL HEAT INPUT (GROSS)	<i>kW</i>	18.59	19.83	21.07
	<i>Btu/h</i>	63,430	67,660	71,890
NOMINAL HEAT OUTPUT	<i>kW</i>	14.65	15.68	16.71
	<i>Btu/h</i>	50,000	53,500	57,000
BURNER SETTING PRESSURE (HOT)	<i>mbar</i>	10.1	11.5	12.9
	<i>in.w.g</i>	4.0	4.6	5.2
INJECTOR		205750		

General Data

1.3 Statutory Requirements

The installation of this must be carried out by a competent person and must be in accordance with the relevant requirements of the current issue of:

Manufacturer's instructions, supplied.

The Gas Safety (Installation and Use) Regulations, Building Regulations, Local Water Company Bye-laws, The Building Standards (Scotland) Regulations, (applicable in Scotland), Health and Safety at Work Act, Control of Substances Hazardous to Health. The Electricity at Work Regulations and any applicable local regulations.

Detailed recommendations are contained in the current issue of the following British Standards and Codes of Practice,

BS6891, BS5546, BS5440 Parts 1 and 2, BS6798, BS5449, BS6700, BS7478, BS7593, BS7671.

Manufacturer's instructions must not be taken as overriding statutory requirements.

1.4 B.S.I Certification

This boiler is certificated by B.S.I., for safety and performance. It is, therefore, important that no alteration is made to the boiler unless agreed, in writing, by Hepworth Heating Ltd.

Any alteration not approved by Hepworth Heating Ltd., could invalidate the B.S.I. certification, boiler warranty and could infringe the Statutory Requirements.

1.5 Gas Supply

The gas installation shall be in accordance with the current issue of BS6891.

The supply from the governed meter must be of adequate size to provide a steady inlet working pressure of 20mbar (8in wg) at the boiler.

On completion test the gas installation using the pressure drop method and suitable leak detection fluid, purge in accordance with the current issue of BS6891.

1.6 Electrical

WARNING. This boiler must be earthed.

The electrical installation must be carried out by a competent person. All external components shall be of the approved type and shall be connected in accordance with the current issue of BS7671 and any local regulations which apply.

Connection of the boiler and any system controls to the mains supply should be through an unswitched shuttered socket outlet and 3A fused 3 pin plug, both to the current issue of BS1363. Alternatively, a 3A fused double pole isolating switch may be used, having a minimum double pole contact separation of 3mm, serving only the boiler and system controls.

Heat resistant cable of at least 75mm² (24/0.20mm), to the current issue of BS6500 Table 16, must be used for all connections within the boiler casing, to the control box, pump etc.

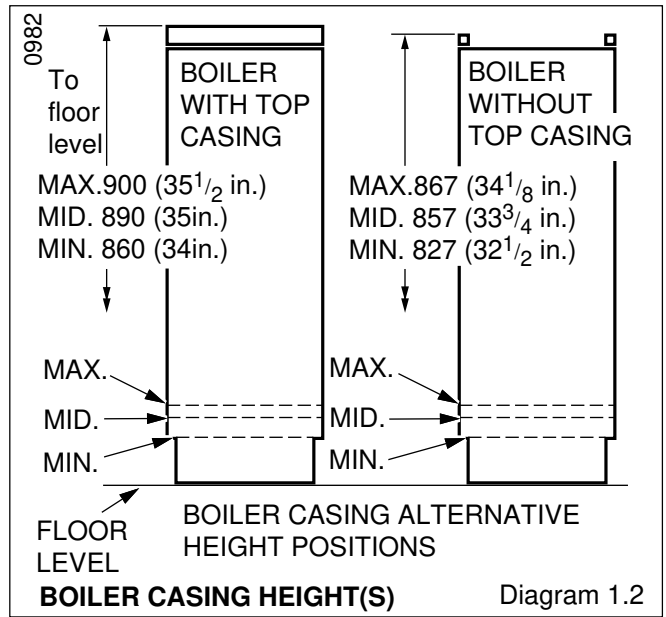

Diagram 1.2

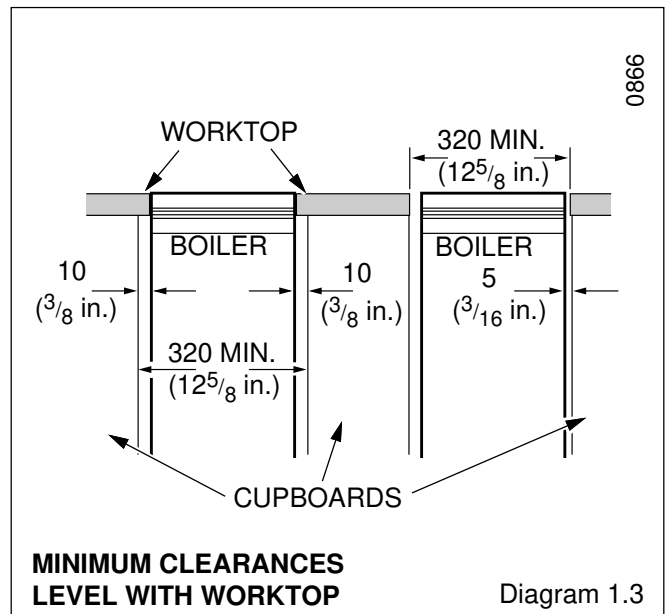

Diagram 1.3

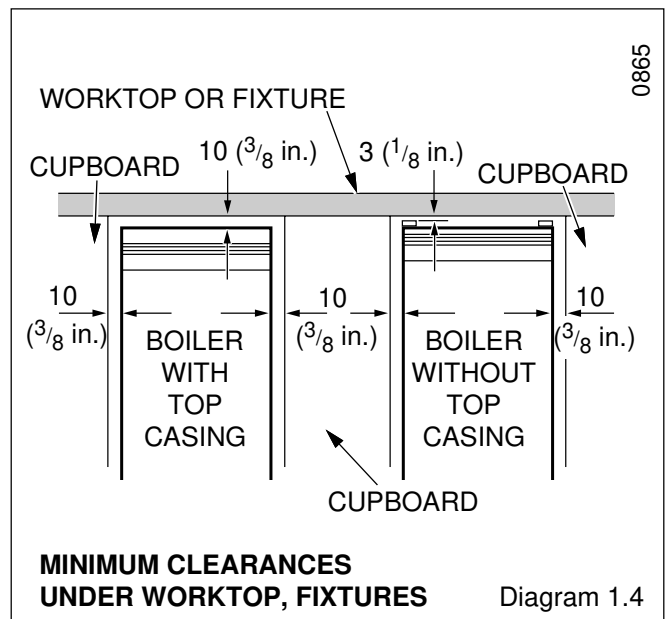

Diagram 1.4

1 General Data

1.7 Boiler Location

The casing can be fitted to the boiler at various heights. The top casing can be discarded if preferred, when fitting the boiler under a low worktop or fixture. Refer to diagram 1.2.

The boiler must stand on a level floor, conforming with local authority requirements and building regulations.

The base temperature is within the requirements of the current issue of BS5258. The boiler may stand on a wooden floor but a metal base plate is required to protect plastic tiles and similar floor coverings.

When the boiler is to be installed level with work surfaces and the like, minimum clearances should be provided as shown in diagram 1.3. Work tops which overhang the cupboard sides, almost in contact with the casing top, require a larger minimum air gap. Flush sided fixtures require the same overall minimum space but can have a reduced air gap on one side.

Boilers to be installed under work tops or fixtures, with or without the casing top fitted should be positioned to provide minimum clearances as shown in diagram 1.4. To facilitate minimum clearances it may be necessary to modify kitchen units and fixtures.

A front access clearance should be provided as shown in diagram 1.5.

The boiler may be installed in any room, although particular attention is drawn to the requirements of BS7671 with respect to the installation of a boiler in a room containing a bath or shower. Any electrical switch should be so positioned that it cannot be touched by a person using the bath or shower. The electrical provisions of the Building Standards (Scotland) Regulations apply to such installations in Scotland.

Where the installation of the boiler will be in an unusual location, special procedures are necessary the current issue of BS6798 gives detailed guidance on this aspect.

A compartment used to enclose the boiler must be designed and constructed specifically for this purpose. An existing cupboard or compartment modified for the purpose may be used. Details of essential features of cupboard or compartment design are given in the current issue of BS6798.

1.8 Heating System Controls

The heating system should have installed: a programmer and room thermostat controlling the boiler.

Thermostatic radiator valves may be installed in addition to the room thermostat.

Note: For further information, see The Building Regulations 1991 - Conservation of fuel and power, 1995 edition - Appendix G, table 4b.

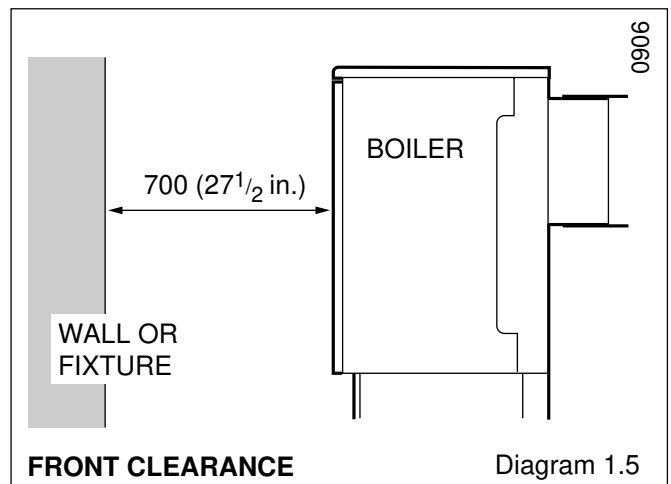

2 Water Systems

2.1 Water Pressure Head

The boiler shall only be connected to a cistern water supply with a minimum head of 1 metre (3ft3in) and a maximum head of 27metres (90ft) which has an open vent in the system.

The working pressure must be within the range 0.1bar to 2.7bar (1.3 to 39lbf/in²).

The boiler MUST NOT be connected to a sealed water system.

2.2 Inhibitor

Attention is drawn to the current issue of BS5449 and BS7593 on the use of inhibitors in central heating systems.

If an inhibitor is to be used in the system, contact should be made with the inhibitor manufacturers so that they can recommend their most suitable product.

When using in an existing system take care to drain the entire system, including the radiators, then thoroughly cleaning out before fitting the boiler whether or not adding an inhibitor.

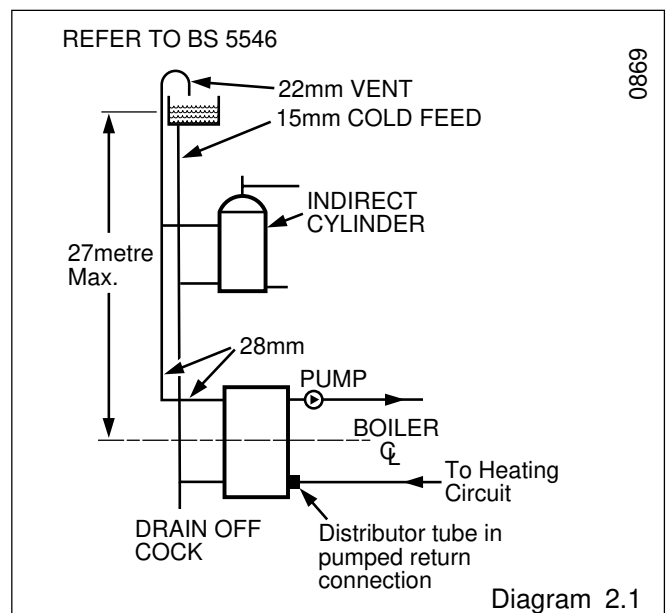

2 Water Systems

2.3 Gravity Domestic and Pumped Heating

It is recommended that a cylinder thermostat is used to prevent the stored water temperature becoming unnecessarily high when the central heating pump is off.

The domestic primary flow and return must be 28mm o.d. The installation must comply with the current issue of BS5546 and BS6700, see diagram 2.1.

If the above conditions cannot be met, it is suggested that a fully pumped system be used.

2.4 Pumped Heating and Hot Water

Where a single flow and return is taken from the boiler, a minimum static head of 1 metre (3ft3in) must be provided between the water line of the cistern and the centre of the waterway, see diagram 2.2.

2.5 Circulation Pump

Normally the pump should be set to give a temperature difference of 11°C (20°F) across the boiler. At the appropriate pumped flow rate the pressure loss through the boiler can be found from the graph, diagram 2.3.

Use a pump with integral valves or fit isolating valves as close to the pump as possible.

Note: If the pump is to be fitted inside the boiler casing a heat shield kit is required. Kit No. 425837.

2.6. Cylinder

For all systems supplying domestic hot water the cylinder must be indirect.

2.7 Safety Valve

A safety valve need not be fitted to an open vented system.

2.8 Draining Tap

A draining tap must be provided at the lowest points of the system which will allow the draining of the entire system, including the boiler and hot water cylinder.

Draining taps should be to the current issue of BS2879.

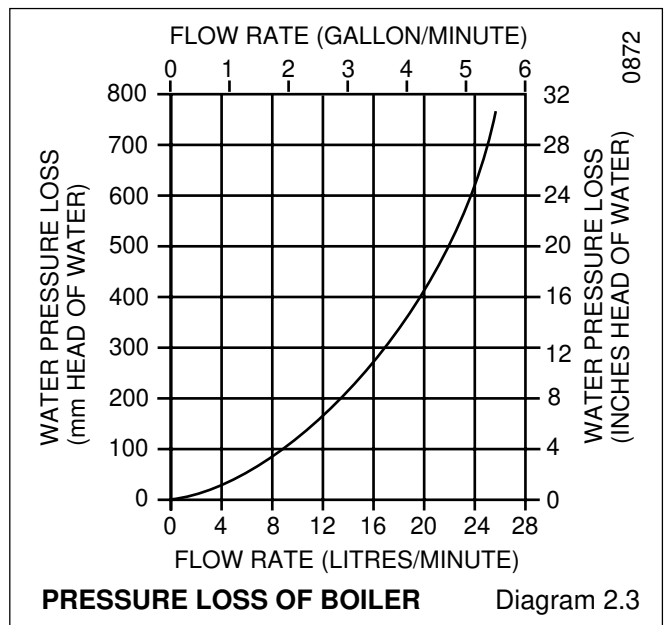
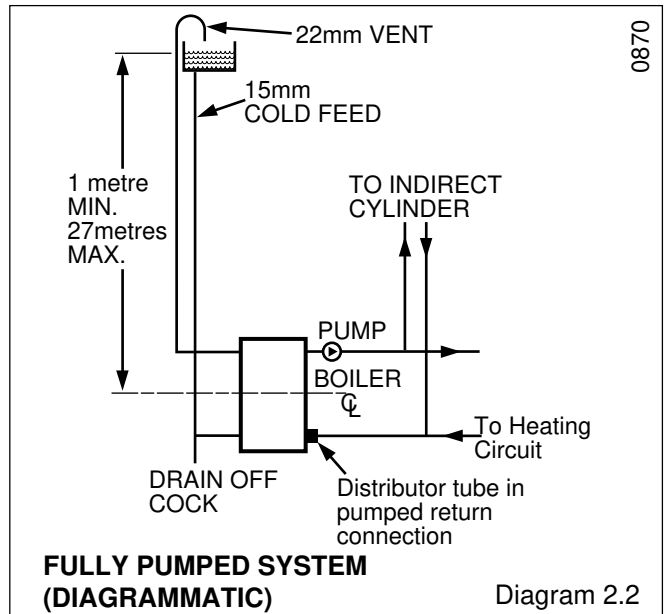

3 Flue and Ventilation

3.1 Flue

Detailed recommendations for flues are given in the current issue of BS5440 Part 1.

The boiler must be installed so that the flue terminal is exposed to the external air. It is important that the position allows the free flow of air across it at all times.

3.2 Terminal Positioning

The minimum acceptable spacings for the terminal to obstructions, other terminals and ventilation openings are given in diagram 3.1.

Car port or similar extensions of a roof only, or roof and one wall, require special consideration with respect to openings, doors and windows under the roof. Care is required in protecting the roof if made from plastic sheeting. Seek further advice if the car port consists of a roof and two or more walls from the local gas undertaking.

Where the terminal is within 850mm (34in) below plastic guttering, an aluminium shield 1.5metres (5ft) long should be fitted to the underside and immediately beneath the guttering.

The air inlet and products outlet duct and the terminal of the boiler must not be closer than 25mm (1in) to combustible material.

3.3 Timber Frame Building

If the boiler is to be installed in a timber frame building it should be fitted in accordance with the Institute of Gas Engineers document IGE/UP/7/1998. If in doubt seek advice from the local gas undertaking or Hepworth Heating Ltd.

3 Flue and Ventilation

3.4 Protecting the Terminal

A terminal guard is required if persons could come into contact with the terminal or the terminal could be subject to damage.

If a terminal guard is required, it must be positioned to provide a minimum of 50mm clearance from any part of the terminal and be central over the terminal.

A guard is available from

Tower Flue Components Ltd.,
Morley Road
Tonbridge,
Kent
TN9 1RA

quoting reference type "F"

3.5 Wall Thickness

Check the wall thickness where the boiler is to be fitted.

Flues available are:

Standard Pack,

part No.424604, 280 to 410mm (11 to 16in).

Short Pack,

part No. 424638, 150 to 280mm (6 to 11in).

Extension Kit,

part No. 424680 + standard pack, 410 to 610 (16 to 24in).

3.6 Room Ventilation

The boiler is room sealed and does not require the room or space containing it to have permanent air vents.

3.7 Cupboard and Compartment Ventilation

Where the boiler is fitted in a cupboard or compartment, the high and low level permanent air vents must have effective areas in accordance with "Compartment Air Vent Table".

Both the high and low level air vents must communicate with the same room or must both be on the same wall to outside air.

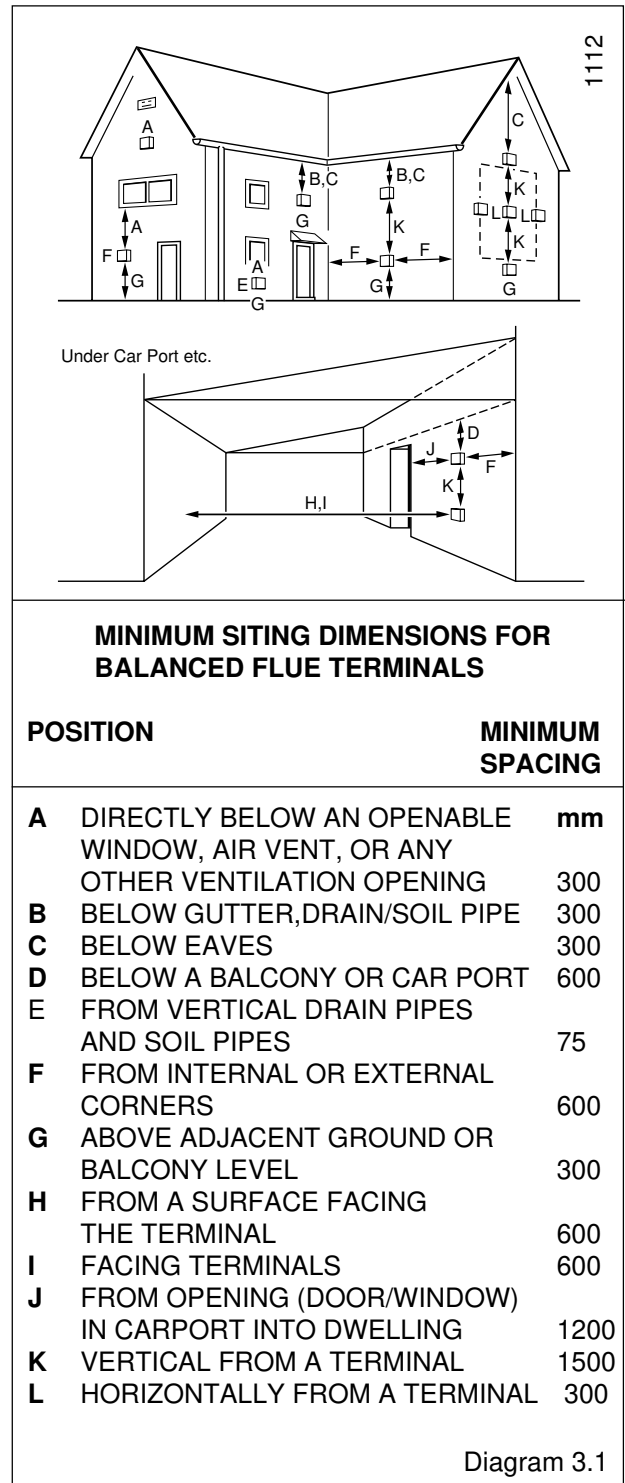

COMPARTMENT AIR VENT TABLE				
COMPARTMENT VENTILATION REQUIREMENTS	HIGH LEVEL VENT AREA		LOW LEVEL VENT AREA	
	VENTILATION FROM ROOM OR SPACE	205cm ²	32in ²	205cm ²
FROM OUTSIDE	103cm ²	16in ²	103cm ²	16in ²

4 Installation

Before fixing the boiler make sure that the location selected is in accordance with the requirements of Section 1.7.

4.1 Unpacking

The boiler casing panels are packed separately within the main carton and are designed to enable gas and water connections to be made before fitting the casing panels.

The casing brackets, distributor tube and loose items, in a plastic bag, are packed in the top fitment.

4.2 Casing Brackets

Fit the two upper and two front casing brackets shown in diagram 4.1. using eight of the No.8 screws.

Push the captive nuts, supplied loose, on to the casing brackets as shown in diagram 4.1.

4.3 Water Connections - Gravity Domestic and Pumped Heating

Fit suitable fittings into the boiler tappings, see diagram 4.2.

Connect pipework into prepared fittings ensuring that all pipes are taken backwards and will clear the casings, see diagram 1.1.

Heating flow: Any one connection of the upper four may be used.

Gravity domestic flow: Any one connection of the remaining upper connections may be used.

Heating return: The distributor tube **MUST** be fitted into either one of the front lower connections on **ALL** installations, see diagram 4.3. The distributor tube is packed in the top carton fitment.

Gravity domestic return: Any one connection of the three remaining lower connections may be used for the gravity domestic return.

When the front connections are used it is essential that any pipework or fittings do not stick out more than shown in diagram 4.6.

If only limited space is available, it is recommended that the front connections are used.

Fit plugs into unused tappings.

Do not route and pipes across the front of the boiler thermostat pocket, controls or the combustion chamber cover.

Pipework must not be routed directly below the draught diverter, across the boiler, but may be routed under the edges of the draught diverter.

4.4 Water Connections - Fully Pumped Systems

It is important that all connections are made as shown in diagram 4.4.

Fit suitable fittings into the boiler tappings as required, see diagram 4.4.

The water distributor tube **MUST BE FITTED** into the return connection, see diagram 4.3.

Connect pipework into prepared fittings ensuring that all pipes are taken backward and will clear the casings, see diagram 1.1.

When the front connections are used it is essential that any pipework or fittings do not stick out more than shown in diagram 4.6.

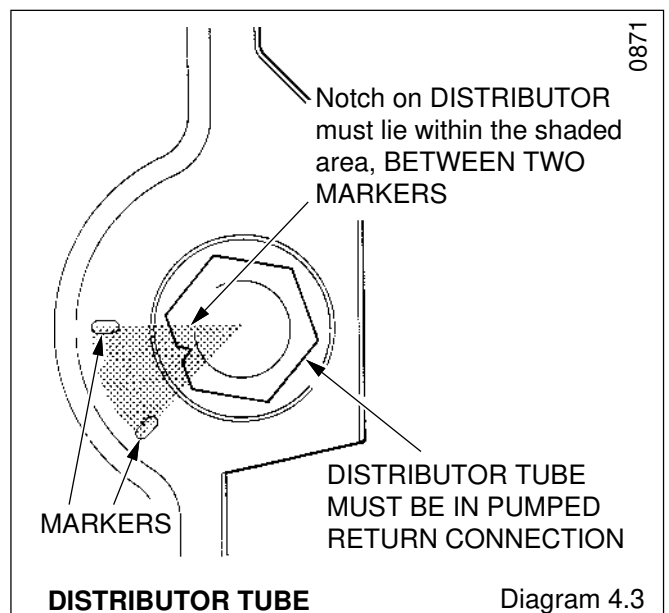
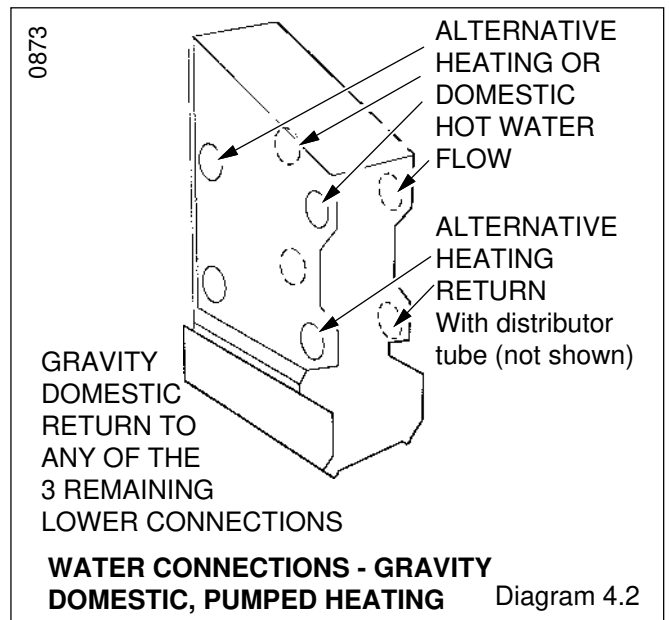
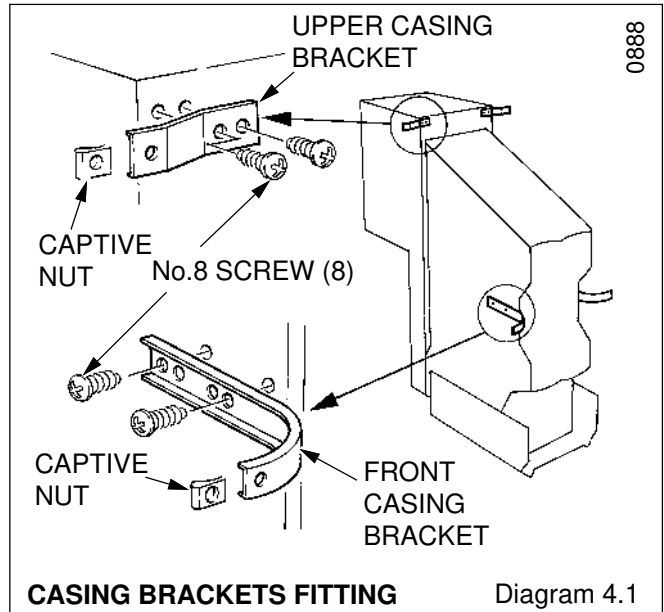

4 Installation

If only limited space is available, it is recommended that the front connections are used.

Fit plugs into unused tapings.

Do not route any pipes across the front of the boiler thermostat pocket, controls or combustion chamber cover.

Pipework must not be routed directly below the draught diverter across the boiler, but is allowed to be routed under the edges of the draught diverter.

4.5 Pump in Boiler Casing

If the pump is to be fitted inside the boiler casing, see diagram 6.2, ensure that a heat shield kit is obtained and fitted (Kit No. 425837).

The kit contains a flueway cleaning door with heat shield (attached).

4.6 Balanced Flue Terminal (Standard and short flue)

Mark out and cut a hole through the wall where the boiler is to be installed, to the dimensions shown in diagram 4.5, after checking that sufficient clearances will be left around the boiler as described in Section 1.7.

Place the boiler in position. The balanced flue ducting will project into the prepared hole in the wall.

Make a good seal around the boiler air duct on the inside wall.

Take the balanced flue assembly from its carton and remove the four screws to release the outer baffle, see diagram 4.8. Remove the four outer wire guards then pull off the inner baffle and flue duct assembly.

Place the air duct assembly into the hole in the wall from the outside, engaging it around the air duct on the boiler and sliding it until the wall plate contacts the outer wall surface.

Seal the joint in the air ducts with the yellow tape provided. Tape four pieces into the four inside corners, followed by four along the joints, overlapping the corner pieces, to make a good seal. Allow a minimum of 20mm ($\frac{3}{4}$ in) overlap of ductings.

Cement around the wall plate to make good and weatherproof.

Refit the inner baffle and flue duct assembly, sealing the joint with the heat resistant semi-transparent tape provided.

Refit wire guards, outer baffle and secure with screws.

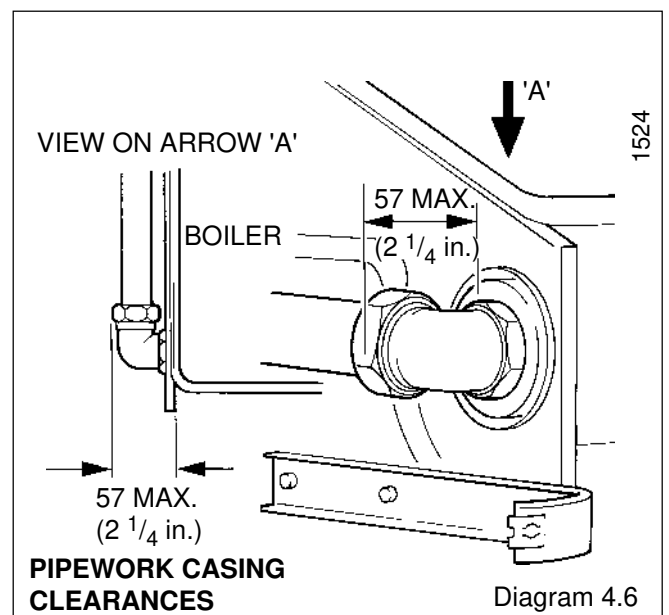
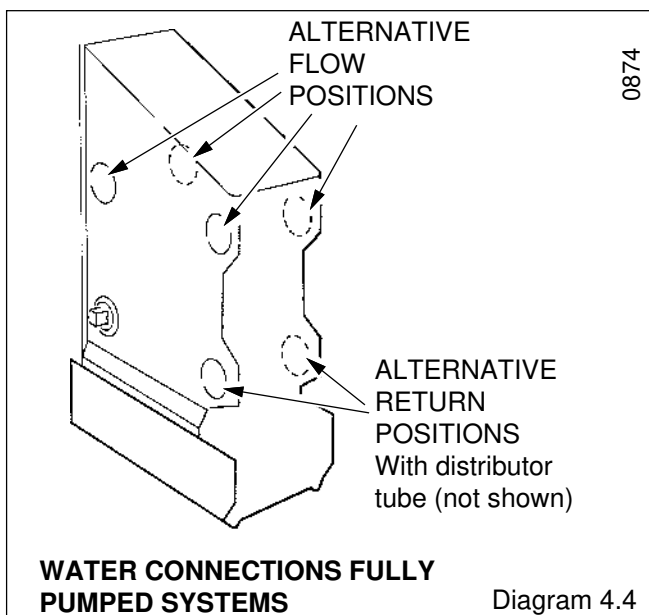
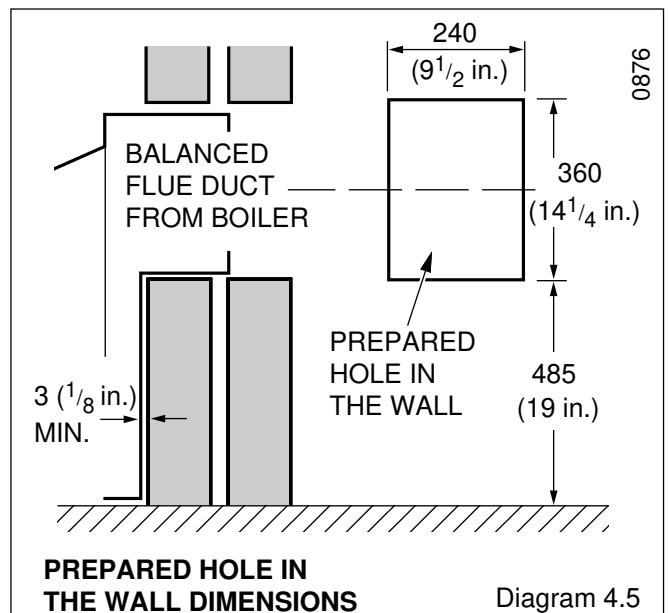

4 Installation

4.7 Boiler Connection

Connect the boiler to the system pipework.

Make the gas connection to the service cock, at the lower right hand side of the boiler.

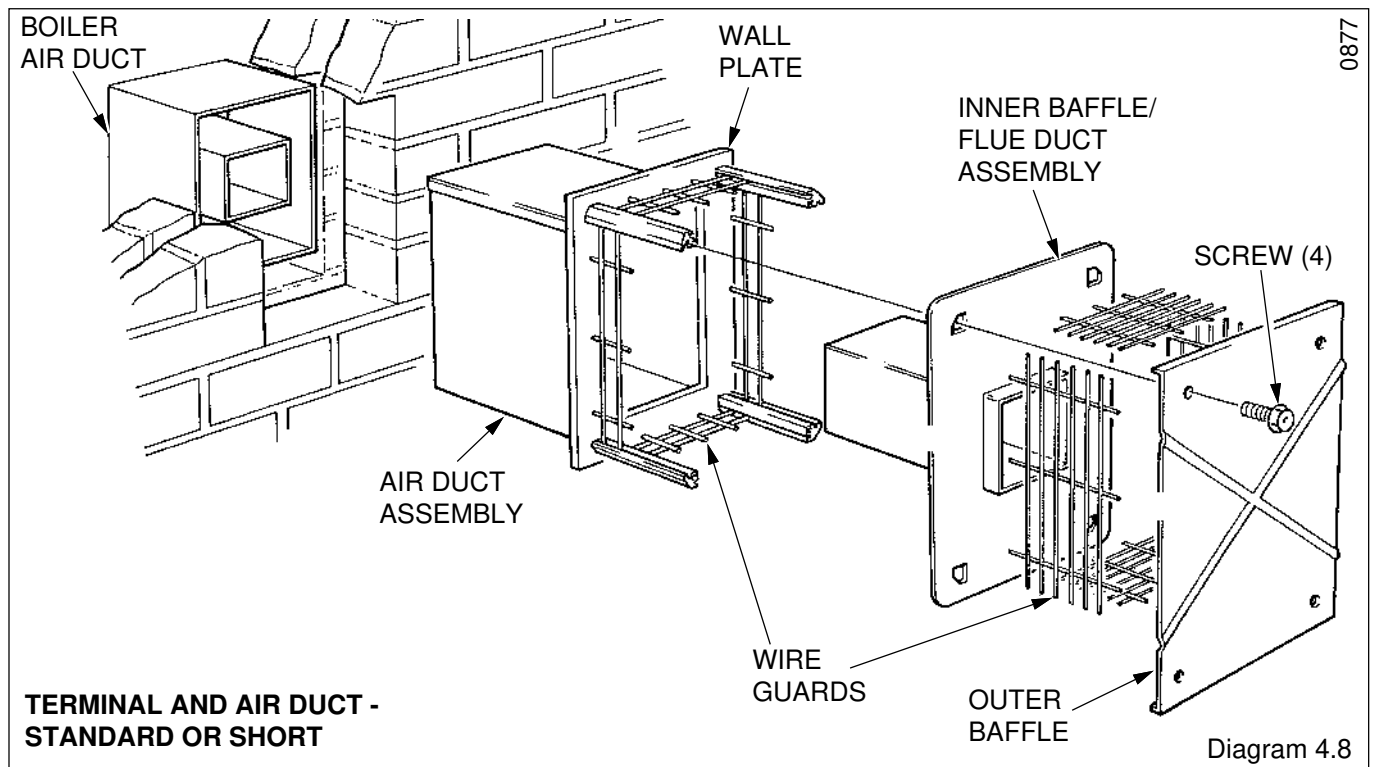
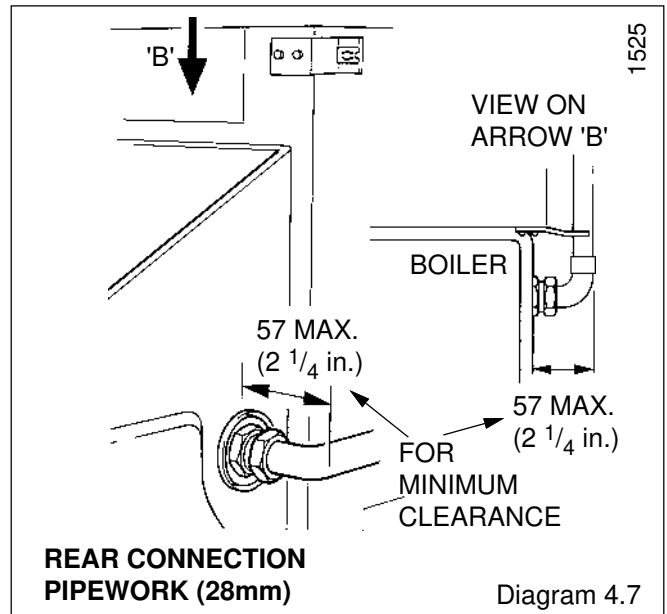

5 Casing Location / Fitting

5.1 Vent Grille

One vent grille is supplied with the boiler, which can be fitted at the rear of the left or right hand side casing. The grille is fitted on the opposite side to any pipework connections.

Fit the grille, if required, to the side panel where no water pipes are connected, as shown in diagram 5.1 prior to fixing the side panel. The plastic pegs are a tight fit and are best pushed home with a flat faced tool.

Discard the grille if the water connections are made on both sides of the boiler or if the boiler is screened by fixtures.

5.2 Side Casings

Fit the side casings by locating their lugs into the appropriate slot in the boiler plinth, see diagram 5.2, depending on the required height, see Section 1.7

Secure the casing sides to the front upper brackets.

5 Casing Location / Fitting

5.3 Top Casing

Fit four plastic pegs into the appropriate holes in the top casing, if being fitted, see diagram 5.3. The plastic pegs are a tight fit and are best pushed home with a flat faced tool. The top casing can be arranged to fit flush with or overhang the door. The top casing is reversible to match, when level with, square or rolled edge work surfaces.

Push the top casing on to all four side casing locations. From inside the casing check that all rivets have located correctly.

For boilers fitted under work tops, not using the top casing, the strap should be fitted using two No.8 screws, see diagram 5.4.

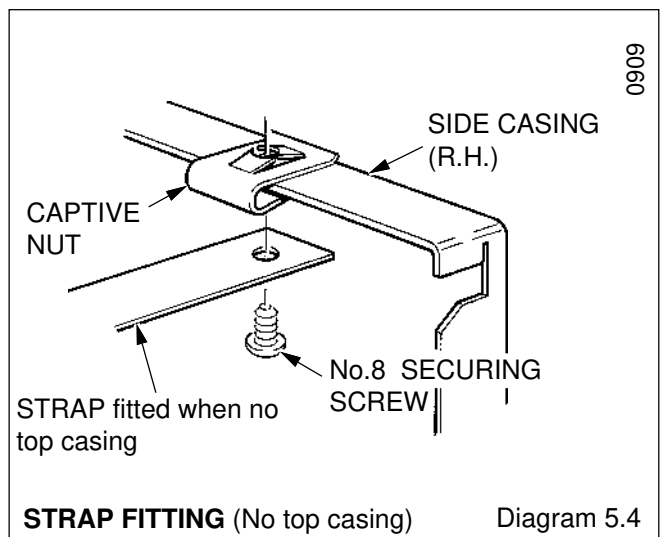
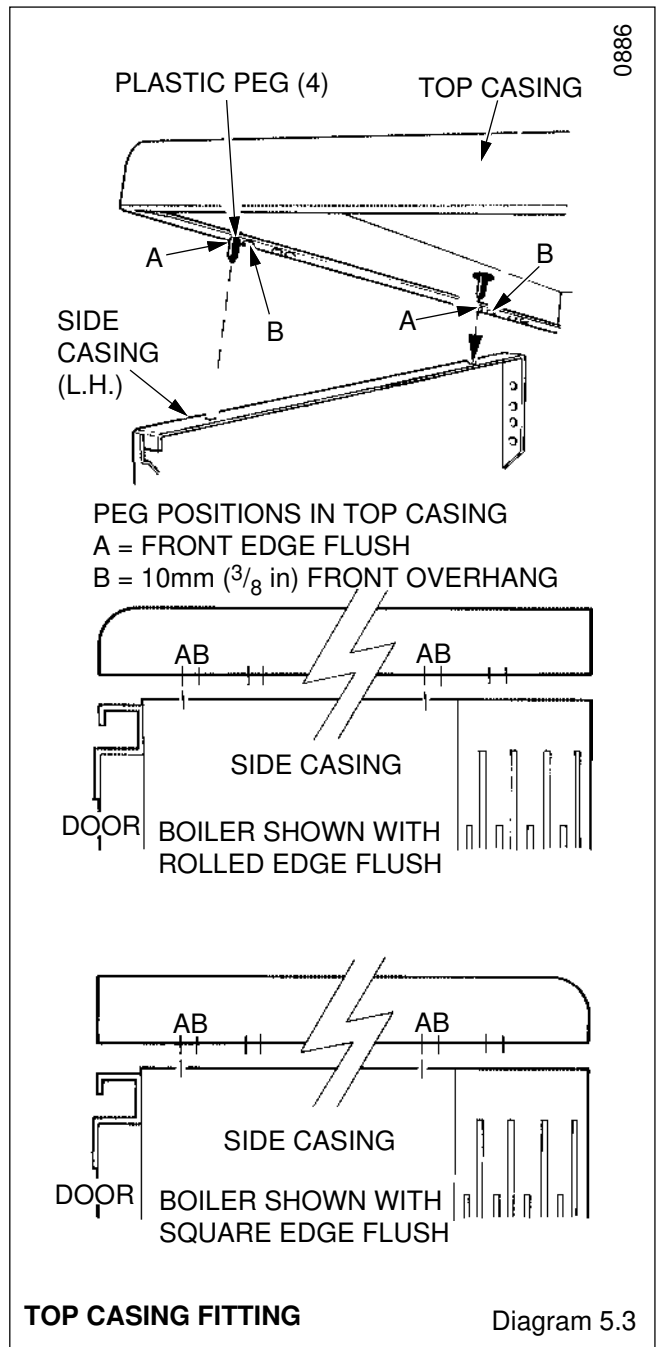
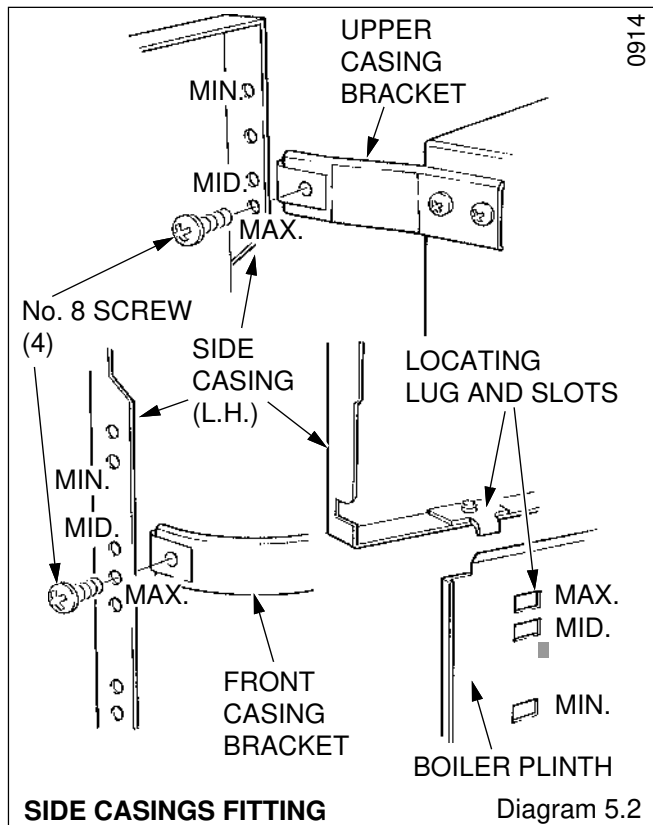
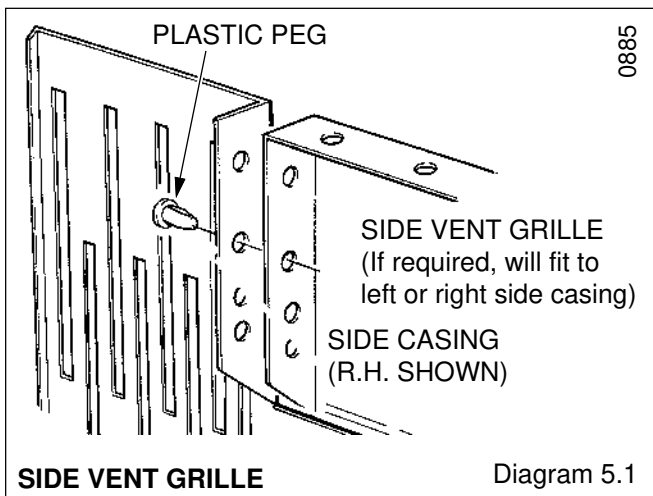

6 Electrical Wiring

6.1 Control Box Cable Connection

WARNING. This boiler must be earthed.

Remove the screw and cover from the mains inlet connector, supplied loose, see diagram 6.1.

Using heat resistant flexible cable of suitable length and rating as in Section 1.6, connect the three cables to the required terminals in the connector. Secure the outer sheathing with the cable clamp.

Engage slots and lugs, replace cover and secure with screw.

Connect the mains inlet connector to the control box and use three of the cable clips, supplied loose, pushed on to the edge of the left hand panel in positions "CB" as shown in diagram 6.2 to ensure the cable does not make contact with any hot surfaces.

6.2 Pump Cable Connection

Heat resistant cable with a rating as stated in Section 1.6 must be used for all wiring near the boiler, including the pump if within the boiler casing.

Support pump cable away from hot surfaces if within the boiler casing by pushing two cable clips, supplied loose, on to the top edge of one side panel, shown as "P" or "AP" in diagram 6.2.

6.3 System Controls

The electrical installation must be made according to the current issue of BS7671.

The electrical isolator must isolate both the boiler and any system controls.

6.4 Testing

Checks to ensure electrical safety should be carried out by a competent person.

In the event of an electrical fault after installation of the boiler, preliminary system checks must be carried out, that is, earth continuity, polarity and resistance to earth, as described in the British Gas Multimeter Instruction Book or similar publication.

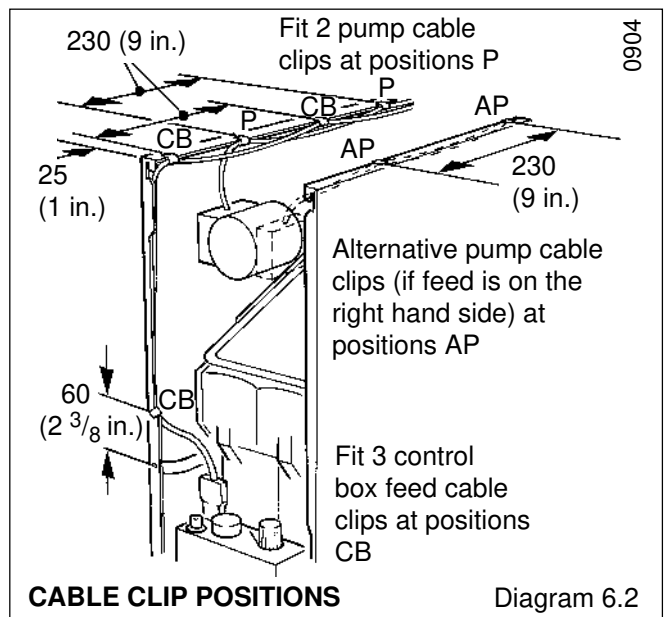
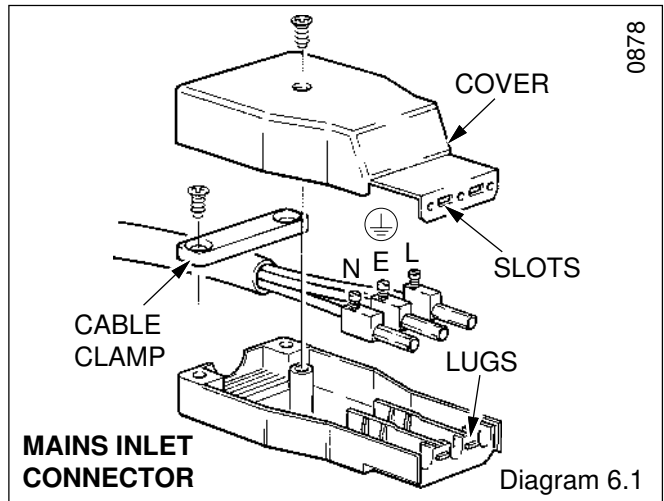

7 Commissioning

Please ensure the "Benchmark" logbook is completed and left with the user.

7.1 Commissioning and Testing the Boiler

The whole of the system should be thoroughly flushed out with cold water with the pump removed. Make sure that all valves are open. Refit the pump and fill the system. Examine for water soundness and vent all air from the system, including the pump.

CAUTION: The following work should be carried out by a competent person.

Identify the boiler controls by reference to diagram 7.1.

Check that the gas service tap "K" is closed, indicator line horizontal.

Open all windows and put out any naked lights, pipes or cigarettes.

Purge air from the gas supply in accordance with the current issue of BS6891.

Make sure that the thermostat phial is positioned at the bottom of the phial pocket "J" located by the washer being behind the split pin.

See that the mains electrical supply is switched off.

Set thermostat control knob "B" to "O".

Remove gas pressure test nipple screw "G" and fit a suitable pressure gauge.

Turn gas control knob "A" to  ignition and pilot position and push in. At the same time push and release piezo unit button "C" until the pilot burner lights. At this stage air may be present in the gas pipes and the lighting operation may need repeating. When the pilot is alight, keep control button "A" fully pushed in

for about 15 seconds. If the pilot burner fails to remain alight, repeat the lighting procedure but now keep the control button pushed in for a little longer.

If the gas control knob "A" is turned to , a safety lock prevents it being turned on again. No attempt should be made to push in knob "A" until 3 minutes have elapsed.

Make sure that the pilot burner is alight and stable, see diagram 7.2 for flame dimensions, then switch the electrical supply on. Set any remote controls for duty. Turn control knob "A" to main burner position '  '. Set thermostat control knob "B" between "MIN" and "MAX" opposite the setting point on the control box, the main burner will then light, "MAX" is about 82°C (180°F).

Test for gas soundness around the boiler with a suitable leak detection fluid.

Set the burner gas rate required ten minutes from lighting, see page 2 for settings. Adjust screw "F", diagram 7.1 to obtain the required heat input. Turn anti-clockwise to increase. The adjusting screw should then be sealed.

Should there be any doubt about the gas rate it should be checked at the meter.

This should be in the range of 1.8 to 2.0m³/h (63 to 71ft³/h).

These rates are for guide purposes, depending on the heat setting.

Stick the self adhesive arrow indicator onto the data label against the output the boiler is to be set to, the arrow is in the fittings pack.

Check the operation of the flame failure device as follows: with the main burner alight, turn gas control knob "A" fully anti-clockwise to its stop '  ', the main and pilot burners will go out.

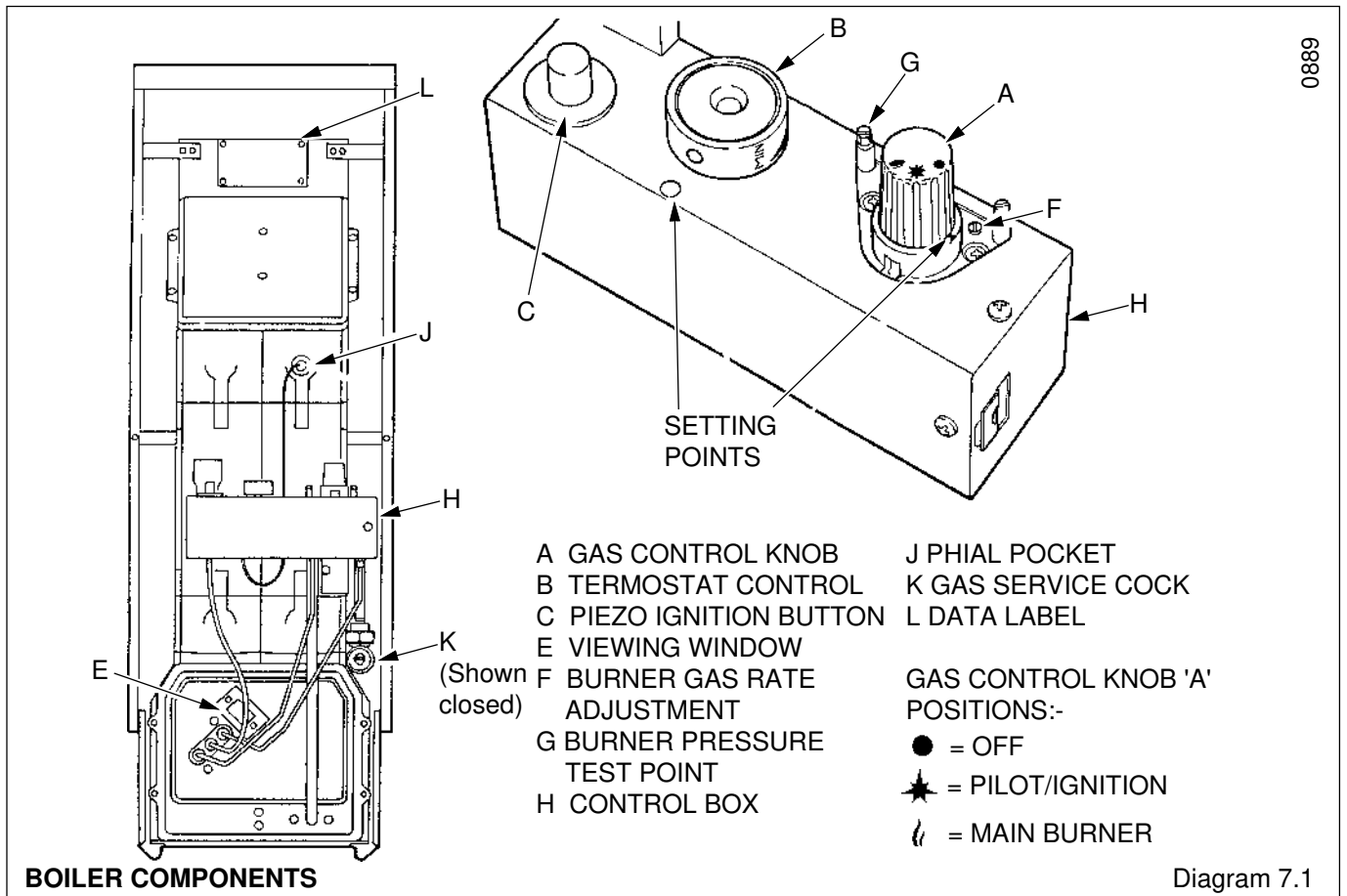

7 Commissioning

Relighting the boiler will not now be possible as a safety device has been activated. After 60 seconds the flame failure device should have closed, indicated by a click from the gas valve. Do not attempt to relight until 3 minutes have elapsed.

Remove the pressure gauge and refit test nipple screw "G".

Turn thermostat "B" to "O" then relight the pilot burner as the relevant part of this Section.

Check that the boiler thermostat and all automatic controls are working correctly.

Do not attempt to adjust the thermostat calibration screw.

Relight the main burner and check for gas soundness with a suitable leak detection fluid.

7.2 Commissioning the System

Allow the system to heat up and set the pump adjuster to a design position which gives a temperature difference of 11°C (20°F) across the boiler.

There should be no undue noise in the system and no pumping over of water or entry of air at the open vent.

Allow the system to reach maximum temperature and examine for water soundness. The boiler should then be turned off and the system drained as rapidly as possible to complete the flushing process.

The system should then be filled again, vented and examined for water soundness.

7.3 Completion

Instruct and demonstrate the efficient and safe operation of the boiler and system.

Hand the Instructions for Use to the user for their retention, making sure that they are understood.

Advise the user that to ensure continued efficient and safe operation of the boiler it is recommended that it is checked and serviced at regular intervals. The frequency of servicing will depend upon the particular installation and usage, but in general once a year should be enough.

It is the law that any servicing must be carried out by a competent person.

Draw attention, if applicable, to the current issue of the Gas Safety (Installation and Use) Regulations, Section 35, which imposes a duty of care on all persons who let out any property containing a gas appliance.

Reminder - Leave these instructions and the "Benchmark" logbook with the user.

Fit the plinth front by locating the sides over the boiler plinth then lowering to engage the upper and lower hooks, see diagram 7.3.

Fit the door by locating the hooked runner at the bottom into the slots in side casings and push on to the studs on the side casings, see diagram 7.3.

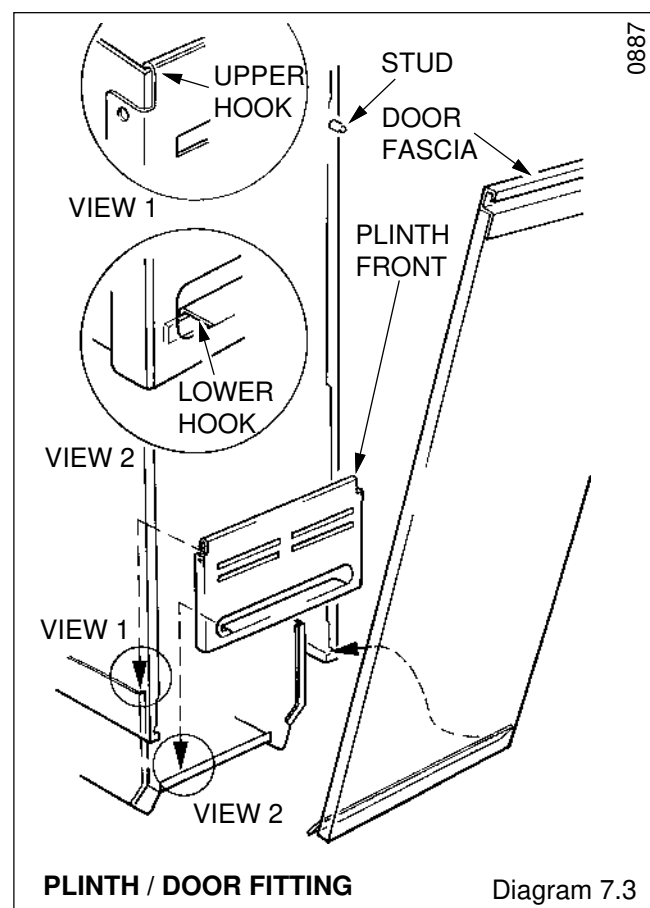
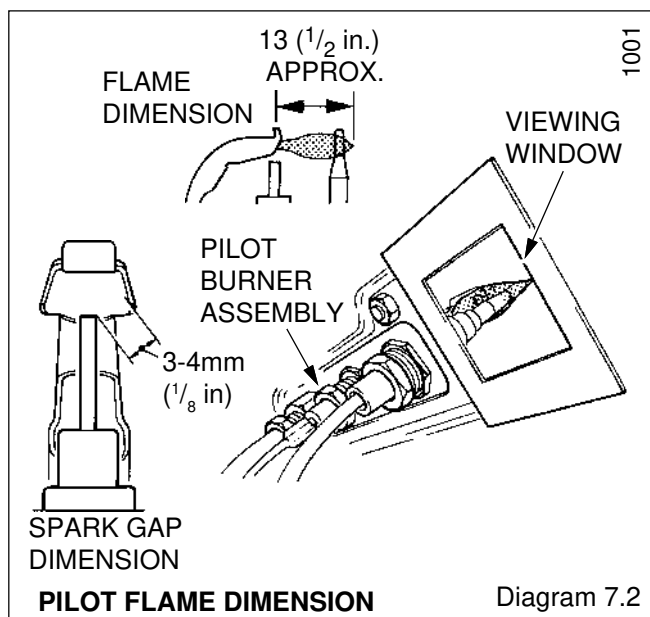

8 Servicing

Servicing must be carried out by a competent person.

Before starting a service, turn off the gas supply at the service cock, see diagram 8.1 and isolate the boiler from the electrical supply.

Always test for gas soundness after completing a service or replacement of parts.

8.1 Boiler Flueways

Pull door forward at the top to disengage studs and lift to release from slots, see diagram 7.3.

Lift the plinth front up and forward to withdraw, see diagram 7.3.

Disconnect the union on the gas service cock, see diagram 8.1.

Remove the mains inlet connector by pulling upward, see diagram 8.1.

Remove the retaining split pin on the thermostat phial pocket then withdraw the phial and capillary, see diagram 8.2.

Remove the four screws retaining the combustion chamber cover and burner assembly, see diagram 8.3. Withdraw forward the complete assembly of cover, control box and burner.

Remove the securing nut to release baffle tray and remove from combustion chamber, taking care not to damage the insulation material on the sides.

Remove the self-tapping screws which retain the cleaning door and lift clear, see diagram 8.4.

Remove flueway baffles, see diagrams 8.5 and 8.6.

Place a sheet of paper in the combustion chamber to catch any flue debris.

Thoroughly clean boiler flueways and fins with a suitable stiff brush.

Replace in reverse order, after completing the relevant instructions in Sections 8.2 and 8.3.

Make sure that the thermostat phial is at the bottom of its pocket and located by the location washer being behind the retaining split pin, see diagram 8.2. Make sure that there is clearance between the thermostat capillary and the boiler.

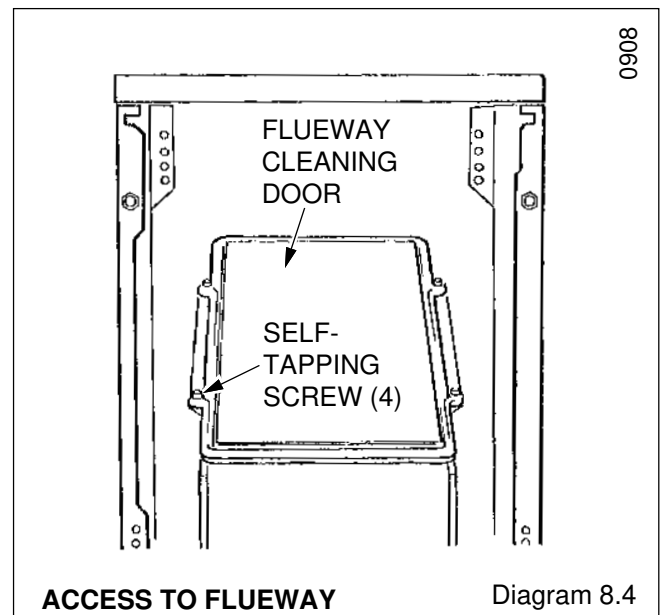
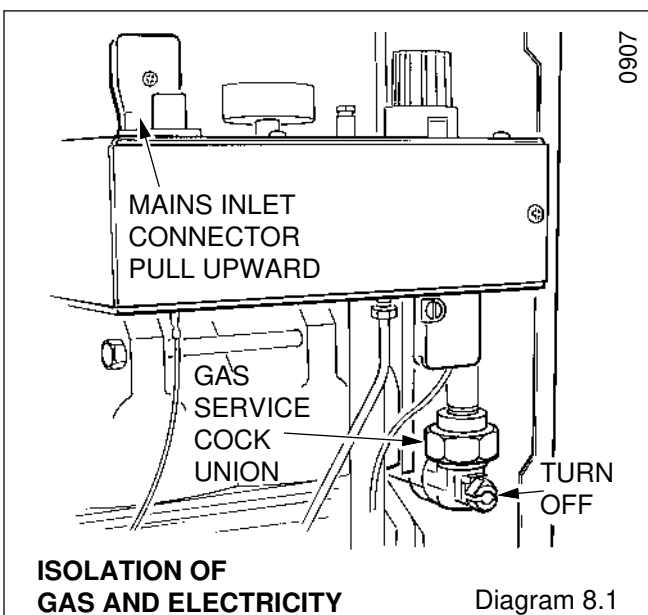
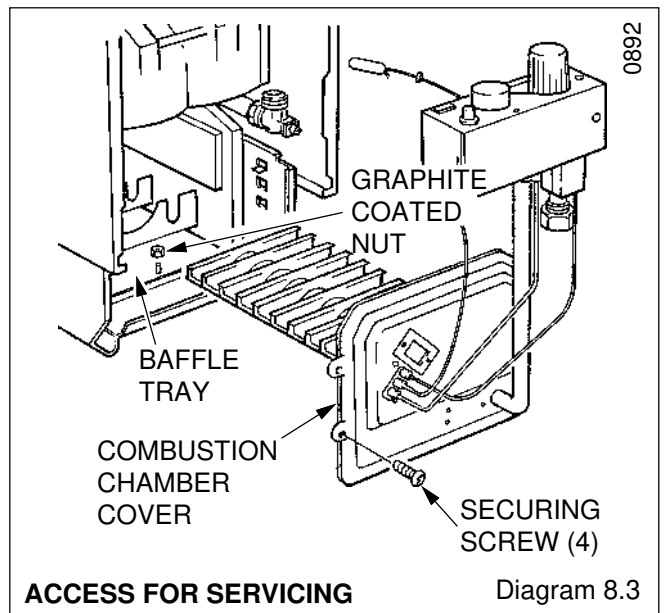
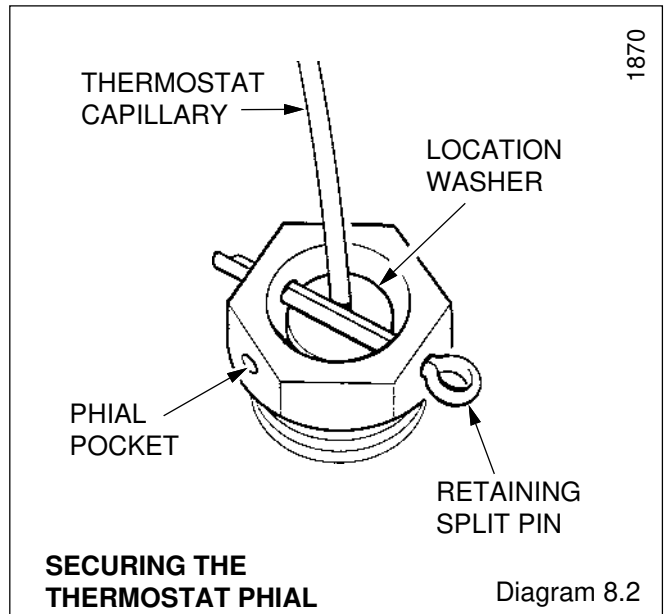

8 Servicing

8.2 Burner and Injector

Follow instructions to remove the cover, burner and controls assembly as in Section 8.1.

Remove the two screws and nuts securing the burner support bracket to the combustion chamber cover, see diagram 8.7.

Remove the graphite coated nuts on the supply feed pipe at the rear of the burner to release the burner, take care not to damage the pilot burner and shield when removing.

Clean burner thoroughly.

Check the main burner injector for blockage or damage and replace if necessary, see Section 9.2 and diagram 8.8.

8.3 Service Checks

Inspect the pilot burner, thermocouple and clean or replace as necessary. If necessary remove the pilot shield by removing the securing screw and nut.

Check the condition of the side and rear insulation panels in the combustion chamber.

Check the condition of the seals on the cleaning door and the combustion chamber cover.

Replace all items in the reverse order, relight and test the boiler.

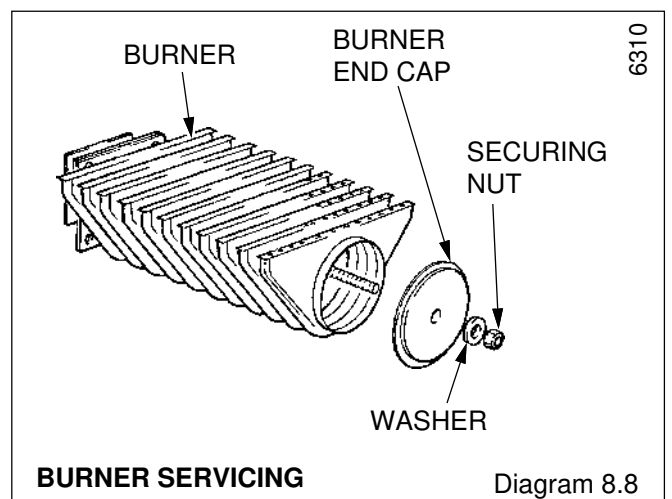
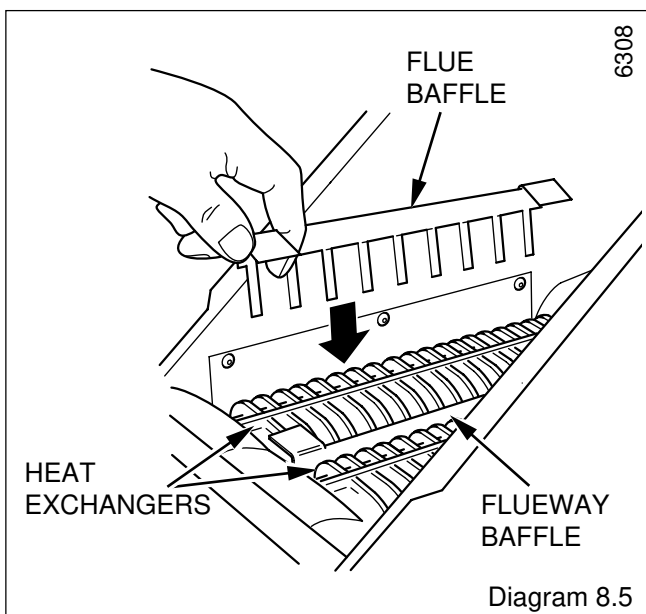
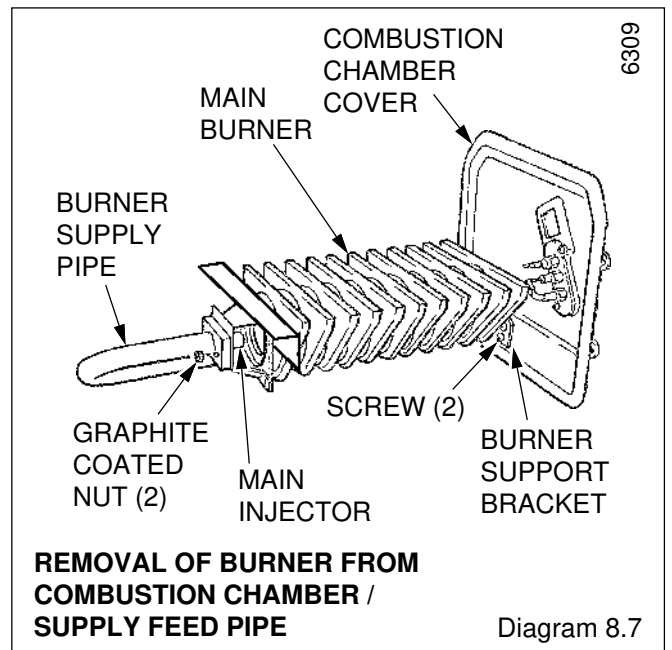
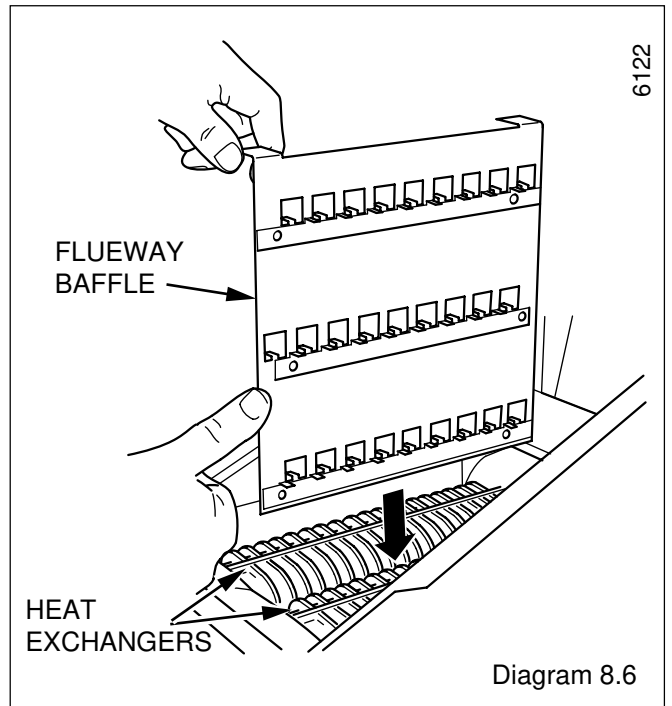

9 Replacement of Parts

Before removing or replacing any parts, turn off the gas supply at the gas service cock, see diagram 8.1 and isolate the electrical supply to the appliance.

Always test for gas soundness after replacing any gas carrying component.

9.1 Gas Valve

Follow relevant instructions in Section 8.1.

Remove control box cover by removing screw and unhooking at the side, see diagram 9.1.

Disconnect electrical connectors, thermocouple nut and pilot tube at the gas valve.

Remove the two screws which secure gas valve to control box.

Tilt control box to enable it to be lifted off the gas valve.

Unscrew the half union from gas valve.

Unscrew gas valve from burner supply pipe.

When screwing the pipe into the new valve use a little jointing compound on the external thread only, to make a gas tight seal.

Replace thermostat phial as Section 8.1.

Reassemble in reverse order.

It will be necessary to purge the system of air after changing the gas valve.

Relighting should be carried out as in Section 7.1.

9.2 Injector

When the burner has been removed from the injector manifold as in Section 8.2 the injector can be unscrewed from the manifold and renewed, as necessary.

When replacing use a little jointing compound on the external thread only, to ensure a gas tight seal.

Replace in reverse order.

Replace thermostat phial as in Section 8.1.

9.3 Thermocouple

Remove the door and plinth as in Section 8.1

Disconnect thermocouple by unscrewing nuts at gas valve and pilot burner, see diagrams 9.1 and 9.3. Release the cable clips and the thermocouple can be withdrawn.

Reassemble in reverse order.

9.4 Pilot Burner

Follow instructions in Section 8.1 to remove cover and burner controls assembly.

Disconnect the thermocouple nut at the pilot burner, see diagram 9.3.

Disconnect the nut retaining the pilot tube and injector in the pilot burner.

Disconnect nut retaining electrode.

Remove the two screws and nuts securing the pilot burner and shield to the front cover, see diagram 9.3.

Reassemble in the reverse order, checking that the spark gap and pilot flame length are as shown in diagram 7.2.

Replace thermostat phial as in Section 8.1.

9.5 Boiler Thermostat

Follow relevant instructions in Sections 8.1 and 9.1.

Pull off the thermostat control knob.

Remove the two screws which secure the boiler thermostat to the control box, see diagram 9.1.

Tilt the thermostat so that the electrical connectors can be removed.

Withdraw boiler thermostat from control box complete with capillary tube and phial attached.

Refer to diagram 9.2 when re-connecting.

Reassemble in the reverse order.

Replace thermostat phial as in Section 8.1.

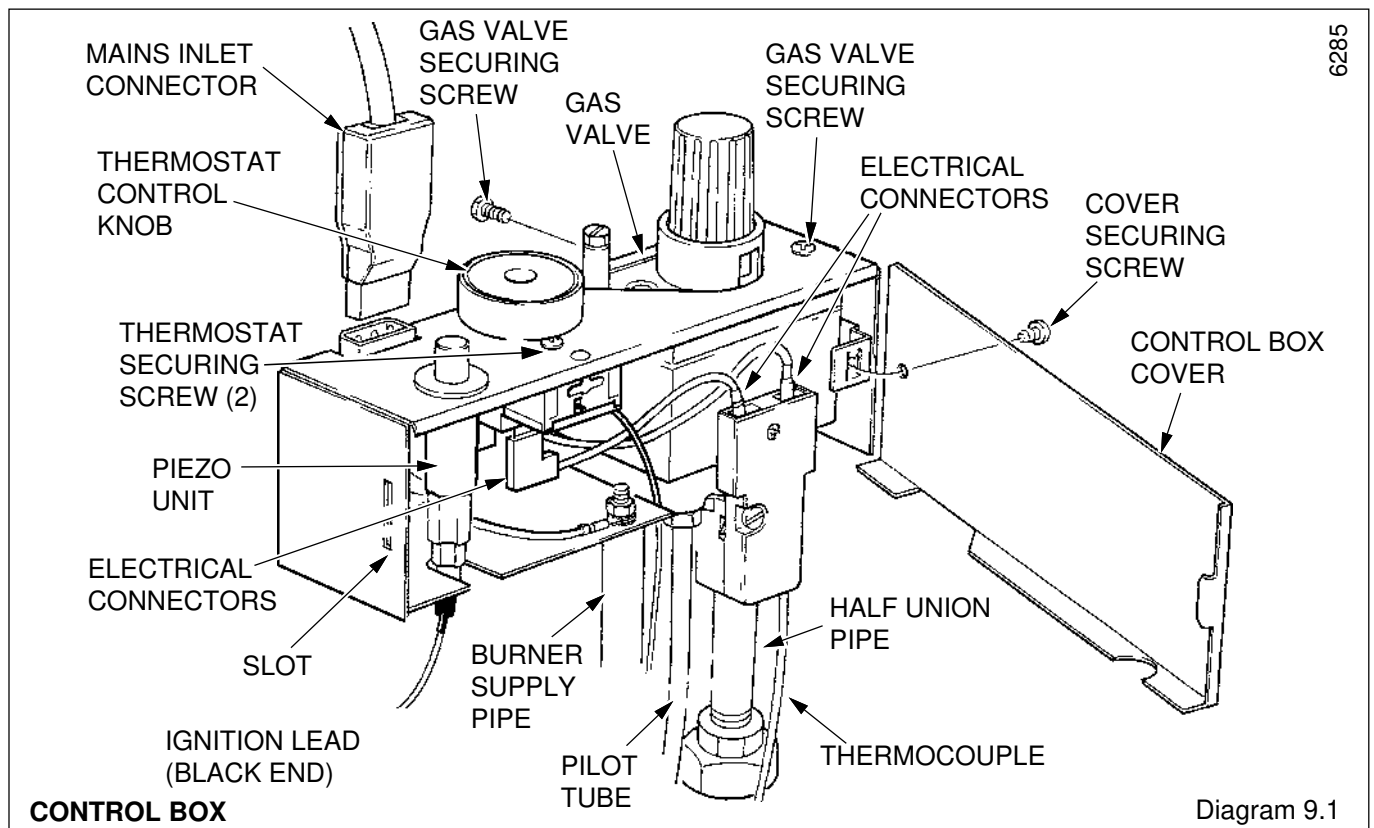
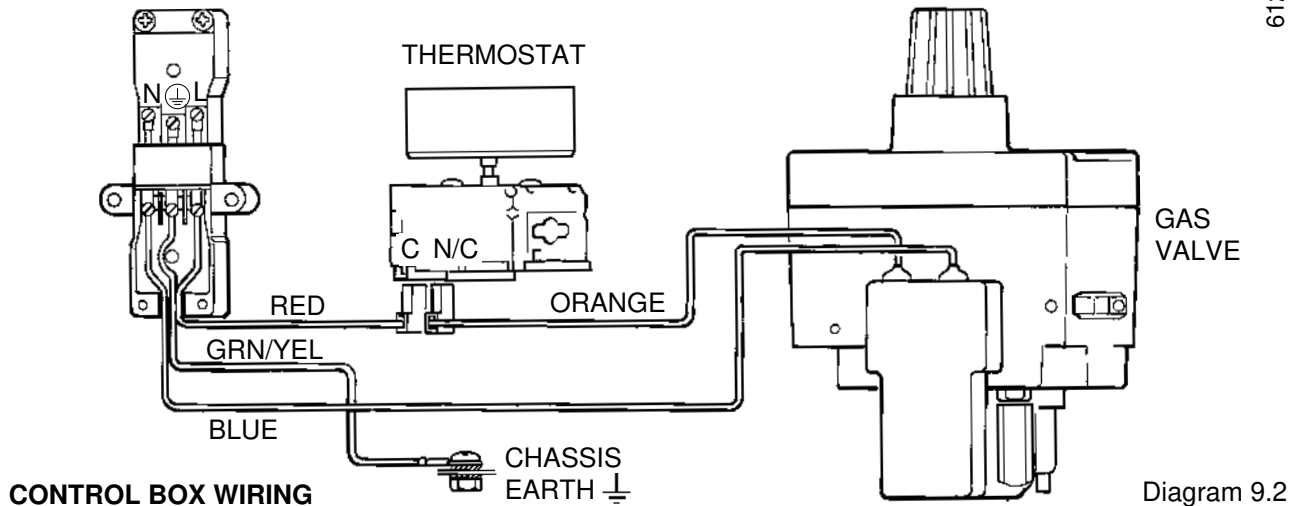

Diagram 9.1

6285

9 Replacement of Parts

240V~ 50Hz MAINS SUPPLY FUSED AT 3A



6124

9.6 Piezo Unit and Ignition Lead

Follow the relevant instructions in Section 8.1.

Pull off ignition lead at piezo unit, see diagram 9.1.

To replace lead also, pull off the lead at the spark electrode terminal, see diagram 9.3.

Remove the control box cover by removing securing screw and unhooking at the side, see diagram 9.1.

Remove the piezo unit, secured by a nut inside the control box. Replace in reverse order.

9.7 Spark Electrode

Follow the relevant instructions in Section 8.1.

Disconnect the thermocouple nut and withdraw the thermocouple from the pilot burner, see diagram 9.3.

Remove the spark electrode, secured by a nut.

Replace in reverse order, checking that the spark gap is as shown in diagram 7.2.

9.8 Insulation Panels

Follow the relevant instructions in Section 8.1.

Remove the two screws retaining each side insulation panel within the combustion chamber and remove panel, see diagram 9.4.

Release the rear insulation panel clips and lift out panel.

Replace in reverse order.

Replace thermostat phial as in Section 8.1.

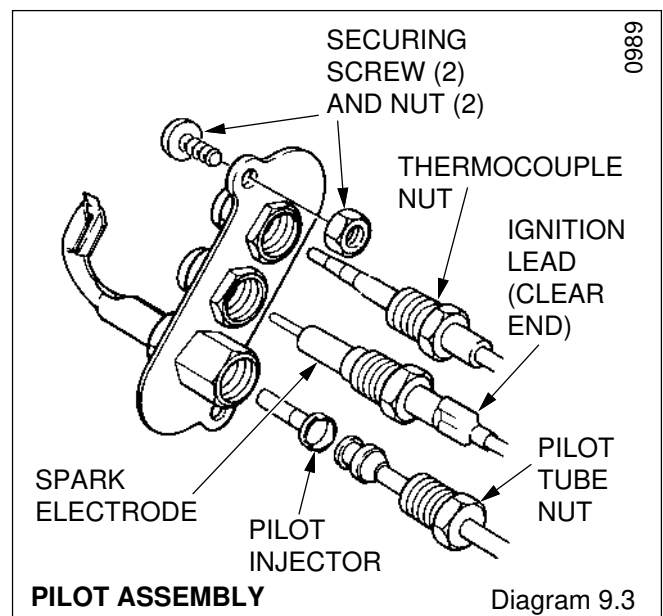

0989

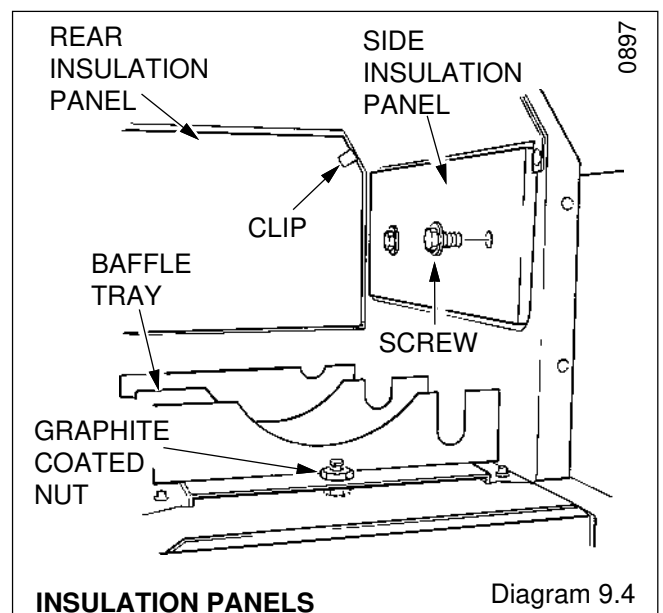

0897

10 Fault Finding - Electrical

10.1 Electrical

Refer to electrical fault finding chart, diagram 10.1, functional flow diagram 10.2 and wiring diagram 9.2.

IMPORTANT: The preliminary electrical system checks as contained in the British Gas Multimeter Instruction Book, or similar publication, are the first checks to be carried out during a fault finding procedure. On completion of the service fault finding task which has required the breaking and remaking of electrical connections, then the checks, earth continuity, polarity and resistance to earth must be repeated.

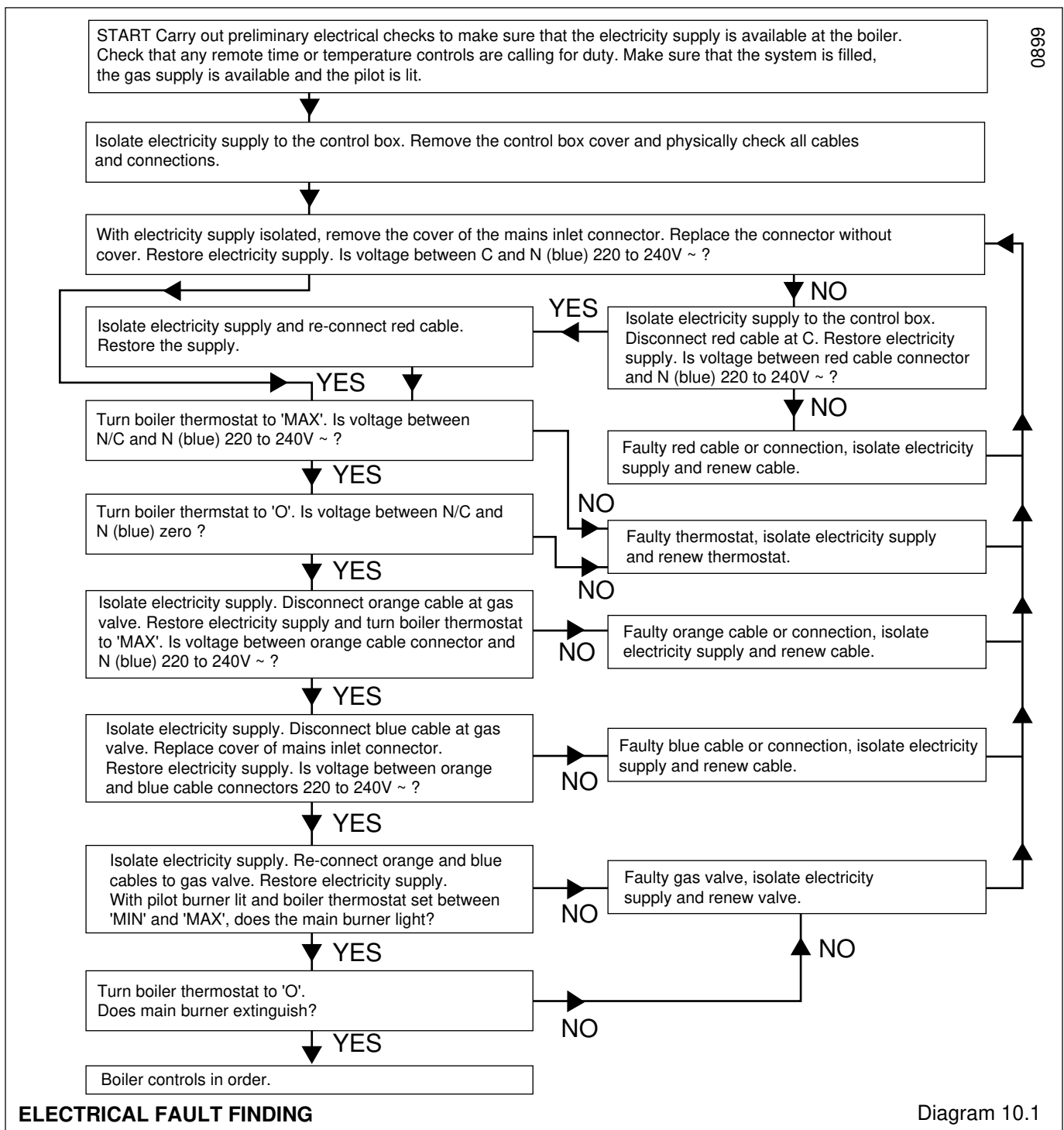
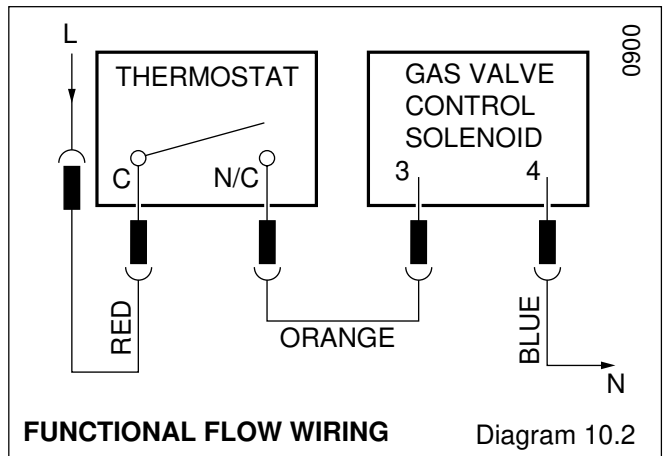

10 Fault Finding - Thermocouple

0194

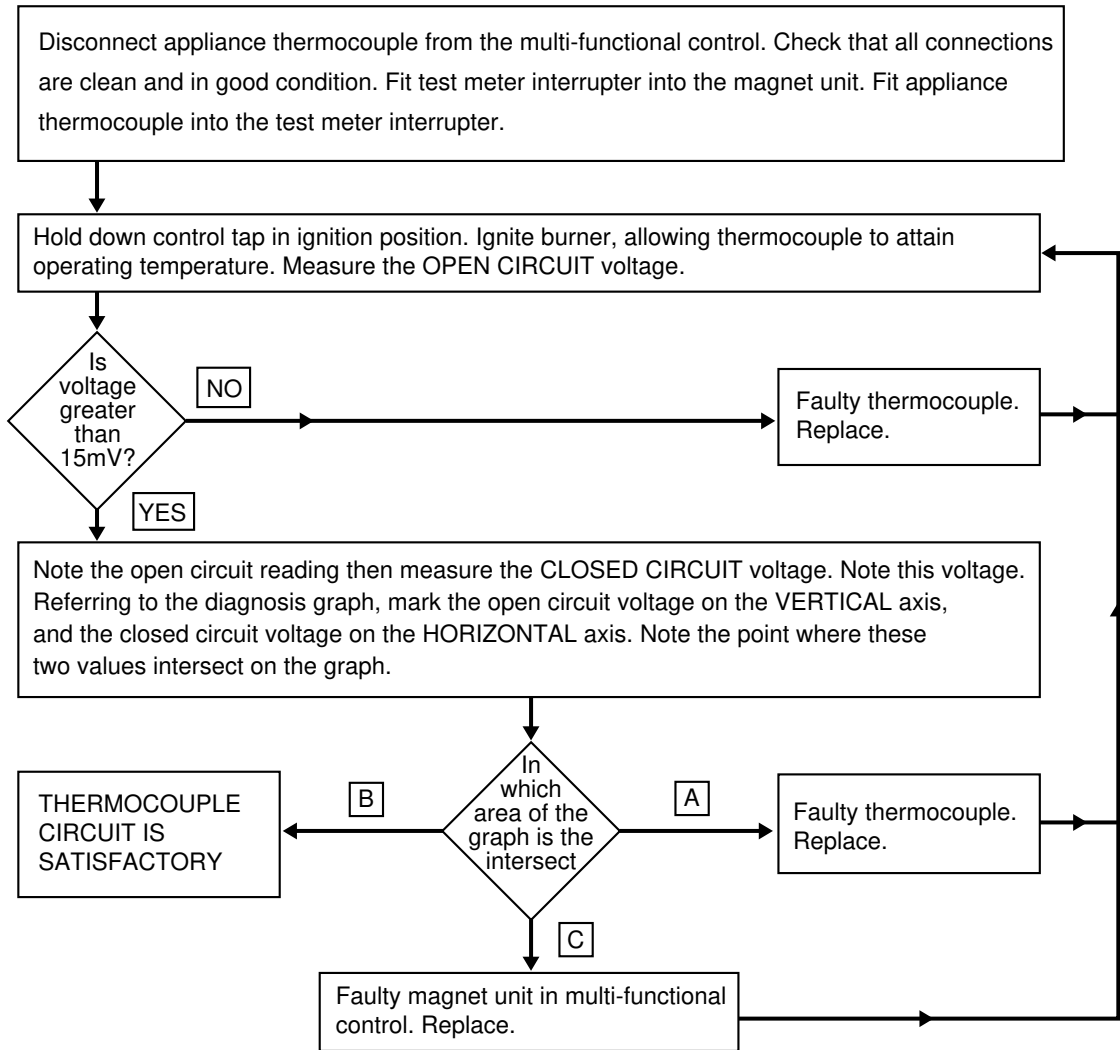

THERMOCOUPLE FAULT FINDING

Diagram 10.3

10.2 Thermocouple

To test the thermocouple a meter with a range of 0 to 30mV is required together with a thermocouple interrupter test unit similar to the British Gas Minitest 6 Unit.

Refer to thermocouple fault finding chart, diagram 10.3 and diagnosis graph, diagram 10.4.

10.3 Pilot

Refer to pilot fault finding chart, see diagram 10.5.

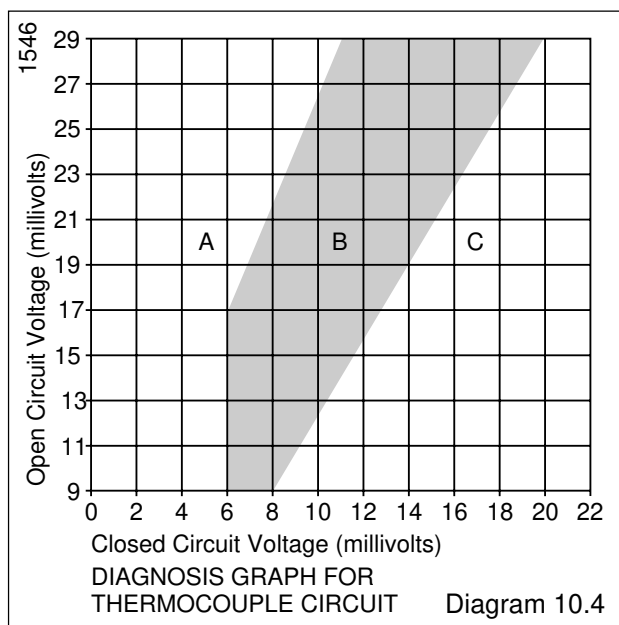

**PILOT WILL NOT LIGHT
START HERE**

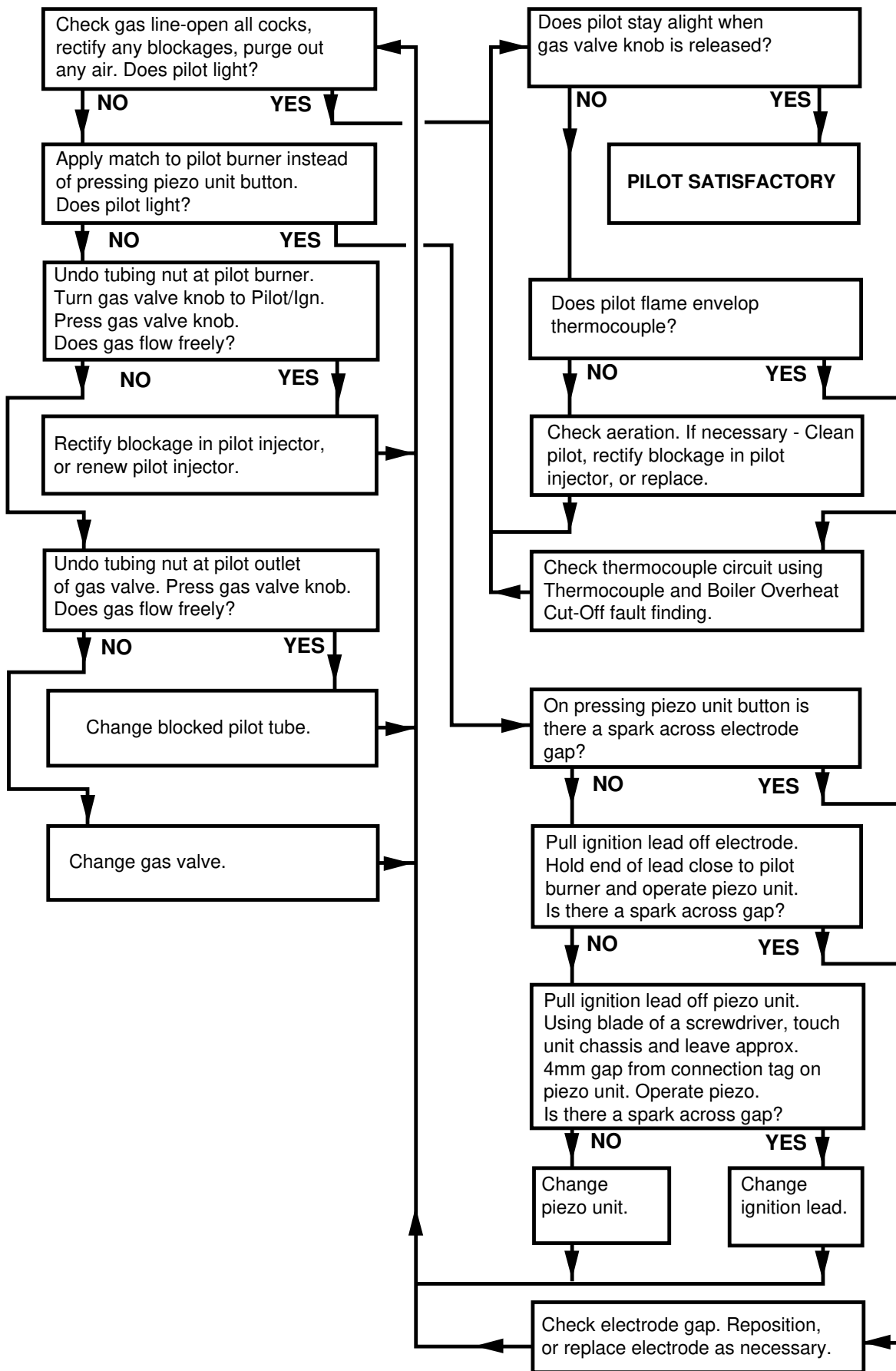

BOILER PILOT FAULT FINDING

Diagram 10.5

11 Spare Parts

The key number in the first column of the list will help identify each part in diagram 11.1.

When ordering spare parts quote the part number and description, stating the model and serial number off the data label "L", see diagram 7.1.

If ordering from British Gas the GC should be quoted.

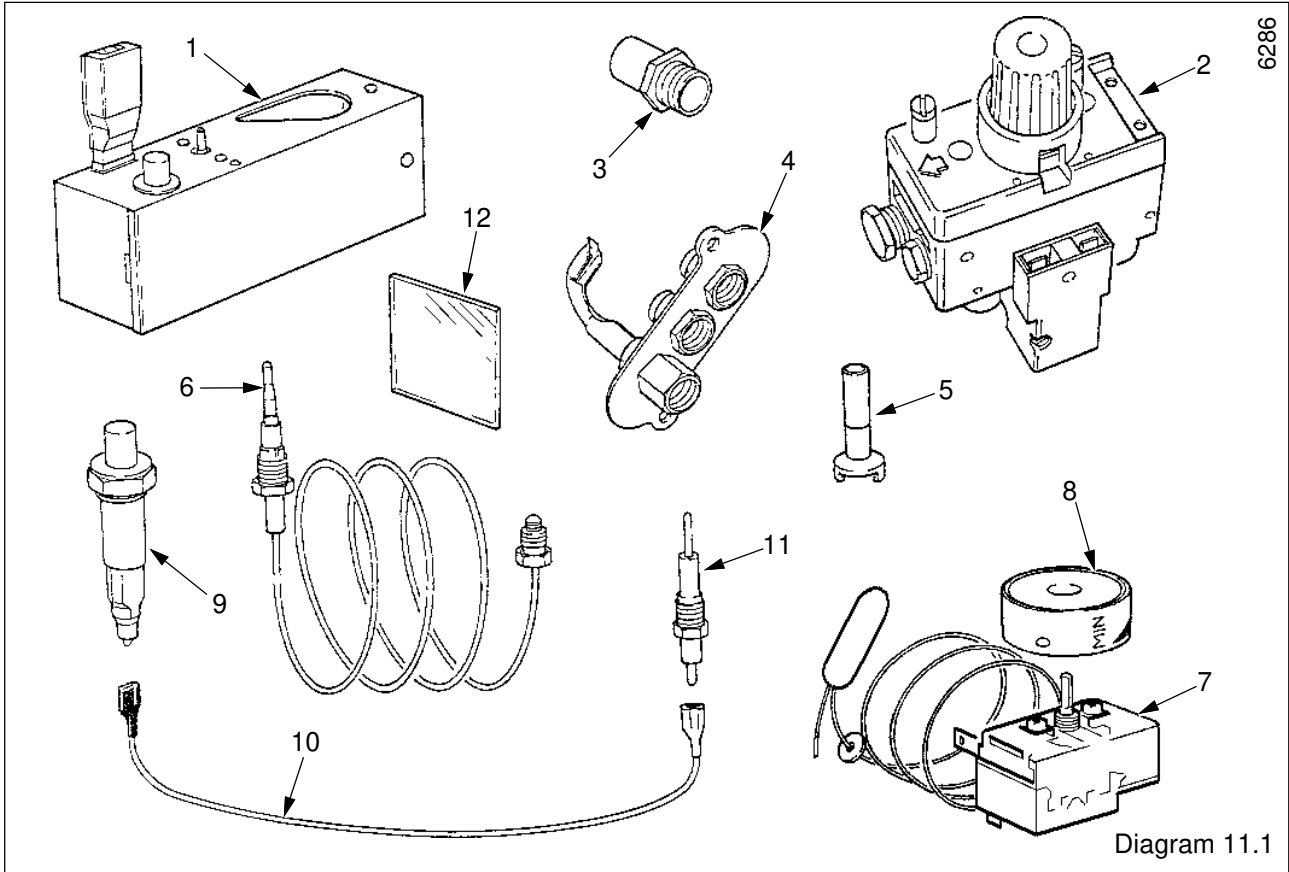

Diagram 11.1

Key No	Part No.	Description	GC Part No.
1	425568	Electrical control box assembly	312 451
2	203329	Gas control valve	384 345
3	205750	Injector	
4	203414	Pilot burner assembly	312 426
5	203508	Injector - pilot	395 674
6	202407	Thermocouple c/w nut	392 934
6	202415		
7	202571	Thermostat c/w screws	
8	FF2228	Control knob assembly	355 241
9	202700	Piezo unit	384 146
9	202702	Piezo unit	382 585
10	WW4613	Ignition lead	136 399
11	202605	Spark electrode	395 720
12	208302	Sight glass	312 419

Because of our constant endeavour for improvement, details may vary slightly from those shown in these instructions.