

Instructions for Use Installation and Servicing

To be left with the user

Energysaver

50e 60e

Cat I_{2H}

G.C. No.

41 319 94

Cat I_{2H}

G.C. No.

41 319 95

High Efficiency Boiler



The mark of quality for domestic heating



PAS010

Reference in these instructions to British Standards and Statutory Regulations/Requirements apply only to the United Kingdom. For Ireland the rules in force must be used.

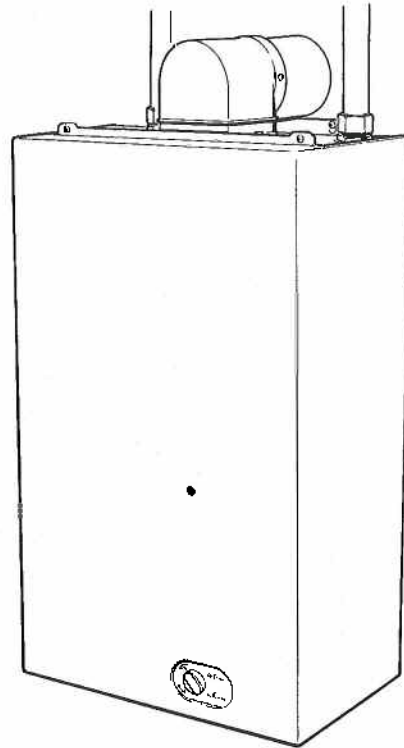

4340S

The instructions consist of three parts, User, Installation and Servicing Instructions, which includes the Guarantee Registration Card. The instructions are an integral part of the appliance and must, to comply with the current issue of the Gas Safety (Installation and Use) Regulations, be handed to the user on completion of the installation.

Guarantee Registration

Thank you for installing a new Glow-worm appliance in your home.

Glow-worm appliances' are manufactured to the very highest standard so we are pleased to offer our customers' a Comprehensive First Year Guarantee.

In the centre pages are to be found your Guarantee Registration Card, which we recommend you complete and return as soon as possible.

If this card is missing you can obtain a copy or record your registration by telephoning the Heatcall Customer Service number 01773 828100.

Our Guarantee gives you peace of mind plus valuable protection against breakdown by covering the cost of:

- All replacement parts**
- All labour charges**
- All call-out charges**

REGISTER YOUR GLOW-WORM APPLIANCE
FOR 1ST YEAR GUARANTEE PROTECTION

CALL 0208 247 9857

HEATCALL

Customer Services:

Tel: (01773) 828100

One Contact Local Service Fax: (01773) 828070

Hepworth Heating Ltd.,
Nottingham Road, Belper, Derbyshire. DE56 1JT
General/Sales enquiries:

Tel: (01773) 824141 Fax: (01773) 820569

Important Information

TESTING AND CERTIFICATION

This boiler is tested and certificated for safety and performance. It is therefore important that no alteration is made to the boiler, without permission, in writing, from Hepworth Heating Ltd.

Any alteration not approved by Hepworth Heating Ltd., could invalidate the certification, boiler warranty and may also infringe the current issue of the Statutory Requirements, see Section 1.2.

CE MARK

This boiler meets the requirements of Statutory Instrument No. 3083 The boiler (Efficiency) Regulations, and therefore is deemed to meet the requirements of Directive 92/42/EEC on the efficiency requirements for new hot water boilers fired with liquid or gaseous fuels.

Type test for purposes of Regulation 5 certified by: Notified body 0086.

Product/production certified by: Notified body 0086.

The CE mark on this appliance shows compliance with:

1. Directive 90/396/EEC on the approximation of the laws of the Member States relating to appliances burning gaseous fuels.
2. Directive 73/23/EEC on the harmonization of the Laws of the Member States relating to the electrical equipment designed for use within certain voltage limits.
3. Directive 89/336/EEC on the approximation of the Laws of the Member States relating to electromagnetic compatibility.

INFORMATION FOR THE INSTALLER AND SERVICE ENGINEER.

Under Section 6 of The Health and Safety at Work Act 1974, we are required to provide information on substances hazardous to health.

Spare Parts

REMEMBER, When replacing a part on this appliance, use only spare parts that you can be assured conform to the safety and performance specification that we require. Do not use

reconditioned or copy parts that have not been clearly authorised by Hepworth Heating Ltd.

CERAMIC FIBRE/INSULATION PADS, GLASSYARN.

These can cause irritation to skin, eyes and the respiratory tract. If you have a history of skin complaint you may be susceptible to irritation. High dust levels are usual only if the material is broken. Normal handling should not cause discomfort, but follow normal good hygiene and wash your hands before eating, drinking or going to the lavatory. If you do suffer irritation of the eyes or severe irritation to the skin seek medical attention.

THERMOSTATS

These contain very small amounts of xylene in the sealed phial and capillary. If broken, under normal circumstances the fluid does not cause a problem, but in case of skin contact, wash with cold water. If swallowed drink plenty of water and seek medical attention.

CUT OFF DEVICES

Cut off devices with copper phial/bulb only.

Bulb contains activated charcoal and very small amounts of chlorodifluoromethane in the sealed phial and capillary. If broken under normal circumstances the fluid does not cause a problem. If there is irritation to the eyes or skin then seek medical attention.

FLUE SEALANT

This contains cyclohexylaminosilane.

It may cause irritation of skin of sensitive persons. Wash contact area with soap and water, if irritation occurs, seek medical advice.

It will cause irritation on contact with eyes. If so, wash eye with large amounts of fresh water for at least 15 minutes. If irritation occurs, seek medical advice.

If swallowed drink plenty of milk and seek medical advice.

CONTENTS	DESCRIPTION	SECTION	PAGE No.
INSTRUCTIONS FOR USE	Introduction		3
	Lighting the Boiler		4
INSTALLATION INSTRUCTIONS	General Data	1	5
	Water System	2	7
	Boiler Location	3	10
	Flue	4	11
	Preparation	5	13
	Water Connections	6	15
	Flue Installation	7	16
	Gas Connection	8	19
	Electrical Connection	9	19
	Commissioning	10	21
User Information	11	22	
SERVICING INSTRUCTIONS	Servicing	12	28
	Fault Finding	13	26
	Replacement Parts	14	33
	Spare Parts	15	39

Instructions for Use

Introduction

Please read these instructions and follow them carefully for the safe and economical use of your boiler.

This boiler is designed to provide central heating from a fully pumped open vented or sealed water system with a fully indirect domestic hot water cylinder.

The boiler is fully automatic in operation, with an "ON/OFF" control switch knob, see diagram 1.

Important Notice

This boiler is for use only on G20 gas.

Gas Safety (Installation and Use) Regulations

In your interests and that of gas safety it is the Law that ALL gas appliances are installed by a competent person in accordance with the current issue of the above regulations.

Gas Leak or Fault

If a gas leak or fault exists, or is suspected, the boiler must be turned off, including the electrical supply and must not be used until the fault has been put right. Advice/help should be obtained from your installation or servicing company or local gas company.

Maintenance and Servicing

To ensure the continued efficient and safe operation of the boiler it is recommended that it is checked and serviced as necessary at regular intervals. The frequency of servicing will depend upon the particular installation conditions and usage, but in general once a year should be enough.

If this appliance is installed in a rented property there is a duty of care imposed on the owner of the property by the current issue of the Gas Safety (Installation and Use) Regulations, Section 35.

It is the Law that any servicing is carried out by a competent person.

Please be advised that the 'Benchmark' logbook should be completed by the installation engineer on completion of commissioning and servicing.

All CORGI Registered Installers carry a CORGI ID card, and have a registration number. Both should be recorded in your boiler Logbook. You can check your installer is CORGI registered by calling CORGI direct on :- 01256 372300.

Boiler Clearances

If fixtures are positioned close to the boiler, space must be left as shown in diagram 3. Enough space must also be left in front of the boiler to allow for servicing.

Boilers Installed In Cupboard or Compartment

If the boiler is installed in a cupboard or compartment do not obstruct any ventilation openings.

Do not use the cupboard or compartment for storage.

Regularly make sure that the air vent openings are clear of obstructions.

Cleaning

Warning. This appliance contains metal parts (components) and care should be taken when handling and cleaning, with particular regard to edges.

Clean the casing occasionally by wiping it over with a damp soapy cloth or dry polishing duster.

Do not use an abrasive cleaner.

Protection Against Freezing

If the boiler is to be out of use for any long period of time during severe weather conditions we recommend that the whole system, including the boiler, be drained off to avoid the risk of freezing up. Make sure that, if fitted, the immersion heater in the cylinder is switched off.

If you have a sealed water system contact your installer or servicing company as draining, refilling and pressurising must be carried out by a competent person.

Boiler Electrical Supply

Warning. This boiler must be earthed.

Connection of the boiler any system controls to the mains (230V~50Hz) must be by one unswitched shuttered socket outlet and fused 3A 3 pin plug.

Alternatively, a 3A fused double pole isolating switch may be used, having a minimum double pole contact separation of 3mm, serving only the boiler and system controls.

The colours of three core flexible cable are:-

Brown - live, Blue - neutral, Green and Yellow - earth.

As the markings on your plug may not correspond with these colours continue as follows:-

The wire coloured brown must be connected to the terminal marked "L" or "Red".

The wire coloured blue must be connected to the terminal marked "N" or "Black".

The wire coloured green and yellow must be connected to the terminal marked "E" or "Green" or the earth symbol .

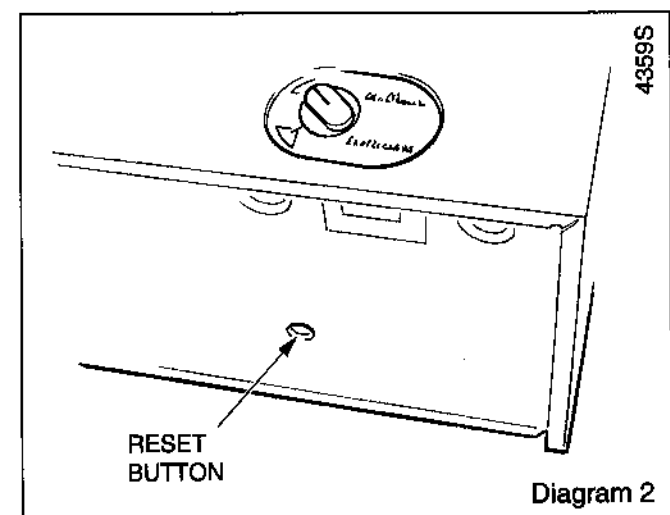
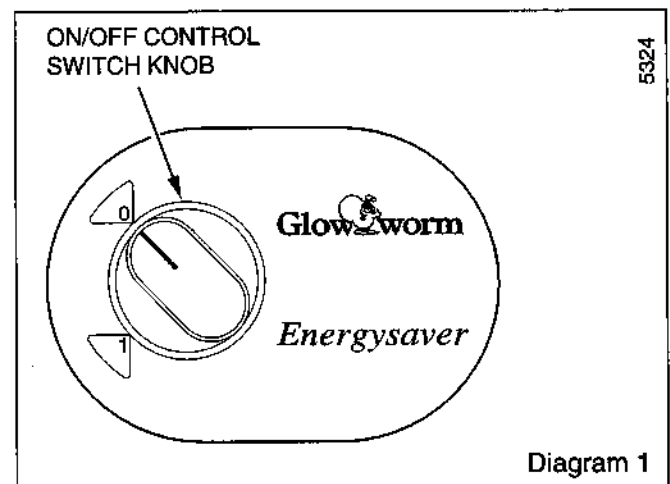

Instructions for Use

Electrical Supply Failure

Failure of the electrical supply will cause the burner to go out. Should this happen, operation of the boiler will normally resume after the electrical supply is restored.

If the burner does not relight after an electrical supply failure the overheat device may need resetting, pull the information panel forwards and push the reset button, see diagram 2.

Overheat Safety Cutoff

If the cutoff operates on any other occasion than electrical failure, press the reset button as stated in "Electrical Supply Failure".

If the boiler fails to relight contact your installer or servicing company.

To Turn the Boiler On

Sealed Water Systems only:

Caution. A sealed water system must be filled and pressurised by a competent person.

Only light the boiler when you are sure that the system and boiler have been filled and pressurised.

The pressure gauge should show at least 0.7bar, anything less than this figure could indicate a leak and you MUST contact your installation or servicing company.

If there is any doubt about the boiler and system being full of water consult your installation or servicing company.

All systems:-

Turn the electrical supply on to the boiler and check that any remote controls are set to your requirements, refer to manufacturer's instructions for these items.

Turn the "ON/OFF" switch to "I".

The boiler lighting operation is now automatic as follows:-

The fan operates, followed by an ignition spark until the burner lights.

The burner will stay alight until switched off by the control thermostat or other remote control.

If the "ON/OFF" switch is turned to "O", "Off" by hand, wait at least 30 seconds before turning on again.

When the boiler thermostat or external controls are satisfied the burner will go out.

The automatic lighting sequence will operate again when heat is required.

Should the boiler fail to come on at the required time, turn the boiler "OFF" and "ON" again. The ignition system will reset and the burner will light.

To Turn the Boiler Off

For short periods, turn "ON/OFF" switch to "O".

To relight the main burner, turn "ON/OFF" switch to "I".

For longer periods, turn "ON/OFF" switch to "O" and switch off the electrical supply.

To relight follow the sequence given above.

Note. If the burner goes out for any reason, wait 30 seconds before relighting.

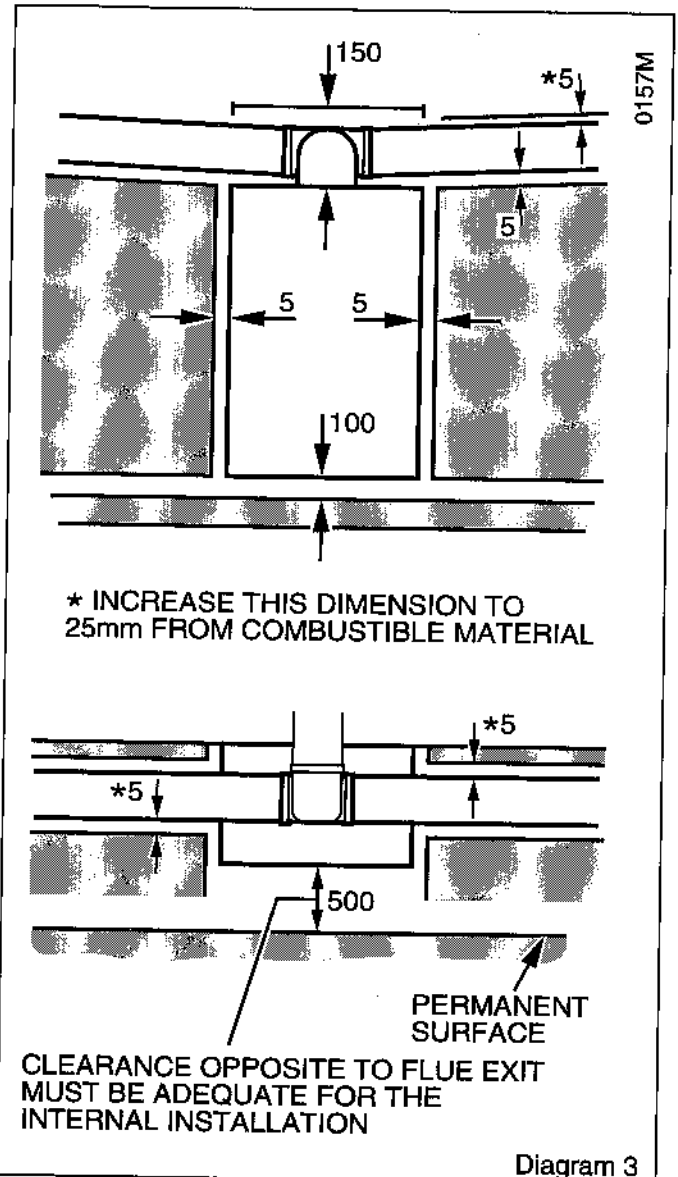

Condensation Plumbing

Like all condensing boilers this appliance will produce a plume of condensation from the flue terminal in cool weather. This is due to the high efficiency and hence low flue gas temperature of the boiler.

1 General

0156M

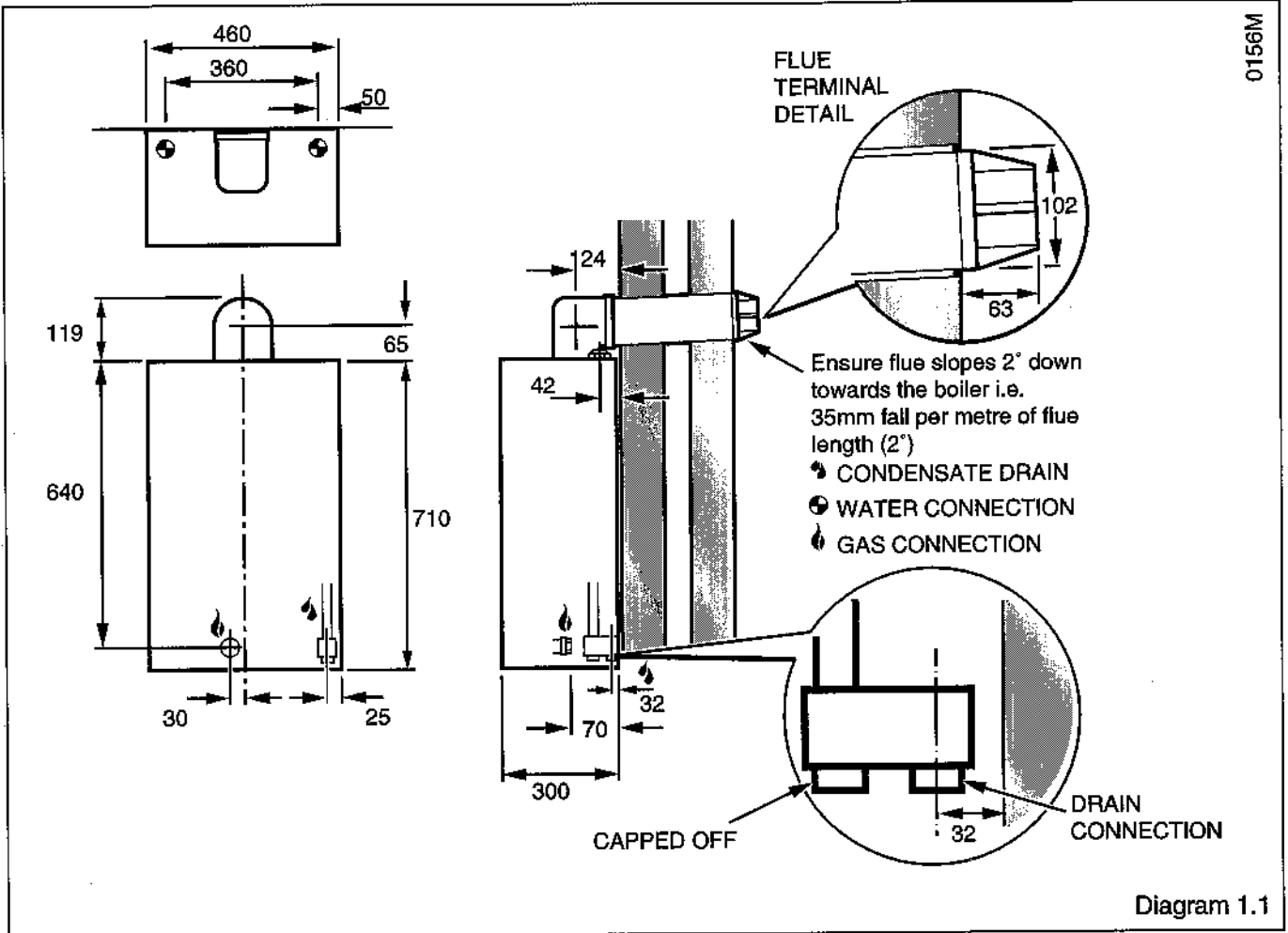

Important Notice

This boiler is for use only on G20 gas.

The boiler is delivered in one pack.

Wherever possible, all materials and components to be used shall comply with the requirements of applicable British Standards.

Where no British Standard exists, materials and equipment should be fit for their purpose and of suitable quality and workmanship.

This boiler must have fully pumped circuits, but is suitable for use with open vented or sealed water systems.

This boiler is not suitable for fitting out of doors.

1.1 Sheet Metal Parts

WARNING. When installing or servicing the boiler care should be taken when handling sheet metal parts to avoid any possibility of personal injury.

1.2 Statutory Requirements

The installation of the boiler **MUST** be carried out by a competent person in accordance with the relevant requirements of the current issue of:-

Manufacturer's instructions supplied.

The Gas Safety (Installation and Use) Regulations, The Building Regulations, The Building Standards (Scotland) Regulations, applicable in Scotland, local Water Company Byelaws, The Health and Safety at Work Act, The Control of Substances Hazardous to Health, The Electricity at Work Regulations and any applicable local regulations.

Detailed recommendations are contained in the current issue of the following British Standards and Codes of Practice:-

BS4814, BS5440 Part 1 and 2, BS5449, BS5546, BS6700, BS6891, BS7074 Part 1 and 2, BS7478, BS7593, BS7671.

We also suggest that you have to hand a copy of the British Gas publication, "Guidance Notes for Installation of Domestic Condensing Boilers".

Manufacturer's notes must not be taken as overriding statutory obligations.

BSI Certification

The boiler is certificated to the current issue of PAS010 for performance and safety.

It is important that no alteration is made to the boiler, without permission, in writing, for Hepworth Heating Ltd.

Any alteration that is not approved by Hepworth Heating Ltd., could invalidate the warranty and could also infringe the current issue of the Statutory Requirements.

1.3 General Data

The data label is positioned on the inner case, visible when the outer case is removed.

All dimensions on diagrams, except as noted, are in millimetres.

The Seasonal Efficiency Domestic Boilers UK (SEDBUK) is 50e 86.8%, 60e 86.9%.

The value is used in the UK Government's Standard Assessment Procedure (SAP) for energy rating of dwellings. The test data from which it has been calculated have been certified by B.S.I.

1 General

DATA TABLE 1

MODEL	50e 60e
TOTAL WEIGHT	48.0 kg (106 lb)
LIFT WEIGHT	31.5 kg (69.5 lb)
WATER CONTENT	1.6 Litre (0.35 gal)
GAS CONNECTION	Rc 1/2 in.
WATER CONNECTION	28mm copper flow at right return at left
ELECTRICITY SUPPLY	230V ~ 50HZ, fused 3A.

TABLE 2. Energysaver 50e

RANGE RATING		
NOMINAL HEAT INPUT (GROSS)	<i>kW</i>	16.94
	<i>Btu/h</i>	57,800
NOMINAL HEAT OUTPUT	<i>kW</i>	14.65
	<i>Btu/h</i>	50,000
NOMINAL HEAT OUTPUT CONDENSING	<i>kW</i>	15.67
	<i>Btu/h</i>	53,500
BURNER SETTING (HOT) PRESSURE	<i>m bar</i>	16.8
	<i>in.w.g</i>	6.72
APPROX GAS RATE	<i>m³/h</i>	1.6
	<i>ft³/h</i>	57
BURNER INJECTOR MARKING: 50N		

TABLE 2. Energysaver 60e

RANGE RATING		
NOMINAL HEAT INPUT (GROSS)	<i>kW</i>	20.33
	<i>Btu/h</i>	69,350
NOMINAL HEAT OUTPUT	<i>kW</i>	17.58
	<i>Btu/h</i>	60,000
NOMINAL HEAT OUTPUT CONDENSING	<i>kW</i>	18.81
	<i>Btu/h</i>	64,150
BURNER SETTING (HOT) PRESSURE	<i>m bar</i>	17.0
	<i>in.w.g</i>	6.8
APPROX GAS RATE	<i>m³/h</i>	1.9
	<i>ft³/h</i>	68
BURNER INJECTOR MARKING: 60N		

1.4 Gas Supply

The gas installation must be in accordance with the current issue of BS6891.

The supply from the governed meter must be of adequate size to provide a steady inlet working pressure of 20mbar (8in wg) at the boiler.

On completion, test the gas installation for soundness using the pressure drop method and suitable leak detection fluid, purge in accordance with the above standard.

1.5 Electrical Supply

WARNING. This boiler must be earthed.

All system components shall be of the approved type and be wired and connected in accordance with the current issue of BS7671 and any applicable local regulations.

Connection of the boiler and system controls to the mains supply must be through a common isolator and must be fused 3A, maximum. This method of connection should be, preferably, by a double pole isolating switch, provided it has a minimum contact separation of 3mm on both poles. This should be readily accessible and preferably adjacent to the boiler. It should supply the boiler only and be easily identifiable as so doing.

Alternatively, an unswitched shuttered socket outlet and 3A fused 3 pin plug both the current issue of BS1363 may be used, provided that they are not used in a room containing a bath or shower.

Wiring to the boiler must be PVC insulated type to the current issue of BS6500 Table 16.

1.6 Condensate

The boiler condensate should, if possible, be discharged into the household internal draining system, that is, sink or washing machine drain. If this is not practicable, discharge can be external, into the household drainage system or a purpose designed soakaway.

The boiler is fitted with a safety device to prevent the boiler working if the condensate pipe gets blocked by either ice or debris.

It is, therefore, recommended that any external condensate drain pipe is insulated to prevent freezing up.

Alternatively, a larger diameter pipe could be used and insulated.

The condensate drain pipe should be checked during any servicing and any debris found removed.

Refer to the British Gas publication "Guidance Note for the Installation of Domestic Condensing Boilers" for further information.

1.7 Heating System Controls

The heating system should have installed: a programmer and room thermostat controlling the boiler.

Thermostatic radiator valves may be installed, however they must not be fitted in a room where the room thermostat is located.

Note: For further information, see The Building Regulations 1991 - Conservation of fuel and power, 1995 edition - Appendix G, table 4b.

1.8 Anti-theft Kits

Anti-theft kits are available for these appliances, contact Hepworth Heating Ltd. for further information.

2 Water System

NOTE:

The boiler has 28mm copper connections, they may, however, be reduced to 22mm, provided that the system resistance does not exceed the chosen pump duty.

2.1 Draining Tap

The boiler is provided with a draining point at the lower left hand side of the burner manifold, to be used for draining the boiler, see diagram 2.1.

A draining tap must be provided at the lowest points of the system which will allow the entire system and hot water cylinder to be drained.

Draining taps shall be to the current issue of BS2879.

2.2 Safety Valve

A safety valve need not be fitted to an open vented system.

2.3 Pump

The pump should be fitted in the flow pipe from the boiler and have isolating valves each side, integral if possible.

A variable duty pump should be set to give a temperature difference of 11°C (20°F) between the flow and return with the thermostat set at "MAX", which is about 82°C (180°F), to give a design flow rate as shown in Table 3.

See chart for pressure drop of the boiler, diagram 2.2.

High resistance microbore systems may require a higher duty pump.

2.4 Bypass

A BYPASS MUST BE FITTED, see diagram 2.3 for a suitable position.

The flow rate through the boiler must not be allowed to fall below that given in Table 3.

Where the water system can allow the boiler and pump to operate on bypass only, the bypass must be placed at least 1.5m away from the boiler.

2.5 Inhibitor

Attention is drawn to the current issue of BS5449 and BS7593 on the use of inhibitors in central heating systems.

If an inhibitor is to be used, contact an inhibitor manufacturer for their recommendations as to the best product to use.

Note. This boiler has a totally copper water system and does not require a special inhibitor normally associated with other types of high efficiency ("condensing") boilers.

If an existing system is to be used take special care to drain the entire system, including the radiators, then thoroughly cleaning out before fitting the boiler, whether or not using an inhibitor.

2.6 Open (Vented) Water System

The boiler must be supplied from an unrestricted water supply taken from a feed an expansion cistern situated at a maximum height of 27metres (90ft) above the boiler.

The cold feed must be 15mm minimum size.

The vent must rise continuously and be unrestricted.

It is important that the relative positions of the pump, cold feed and open vent are as shown in diagram 2.3.

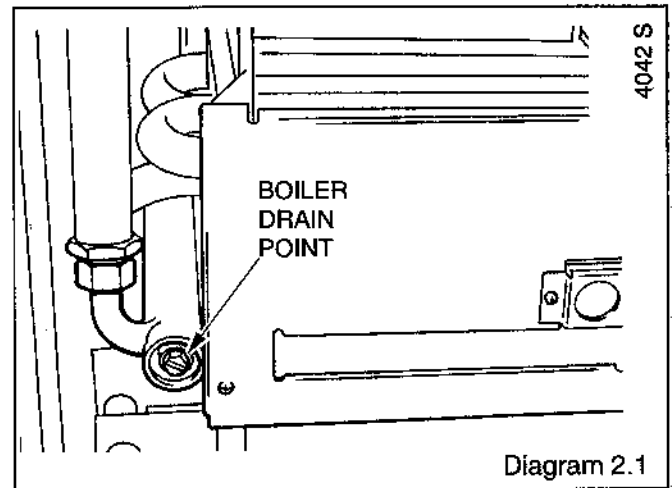

Diagram 2.1

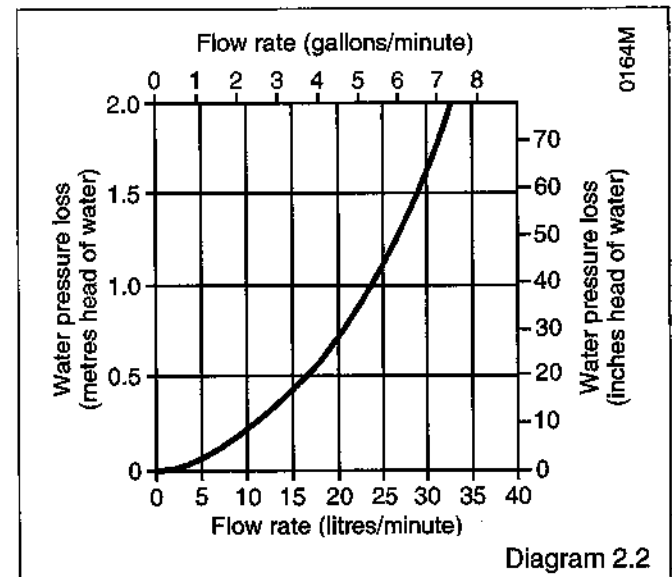

Diagram 2.2

TABLE 3.

	Design Flow Rate	Minimum Flow Rate
<i>Energysaver 50e</i>	19L/m	14L/m
<i>Energysaver 60e</i>	23L/m	17L/m

2 Water System

2.7 Domestic Hot Water Cylinder

The domestic hot water cylinder must be of the double feed fully indirect type. Not the single feed self priming type.

2.8 Domestic Hot Water System - Unvented

Where a storage system will not have a vent to atmosphere the installation must comply with The Building Regulations and the local Water Company Byelaws, see also the current issue of BS6700.

If fitting to an existing system the local authority should be informed.

2.9 Sealed Water Systems

The installation must comply with the appropriate requirements of the current issue of BS4814, BS5449, BS6759, BS6798 and BS7074 Part 1 and 2.

See diagram 2.4 for a suggested layout.

2.10 Safety Valve

A safety valve must be fitted to a sealed water system.

It shall be preset, nonadjustable with a lift pressure of 3bar, incorporating seating of a resilient material, a test device and a connection for drain.

The drain from the safety valve must be routed clear of any electrical fittings and positioned so that any discharge can be seen.

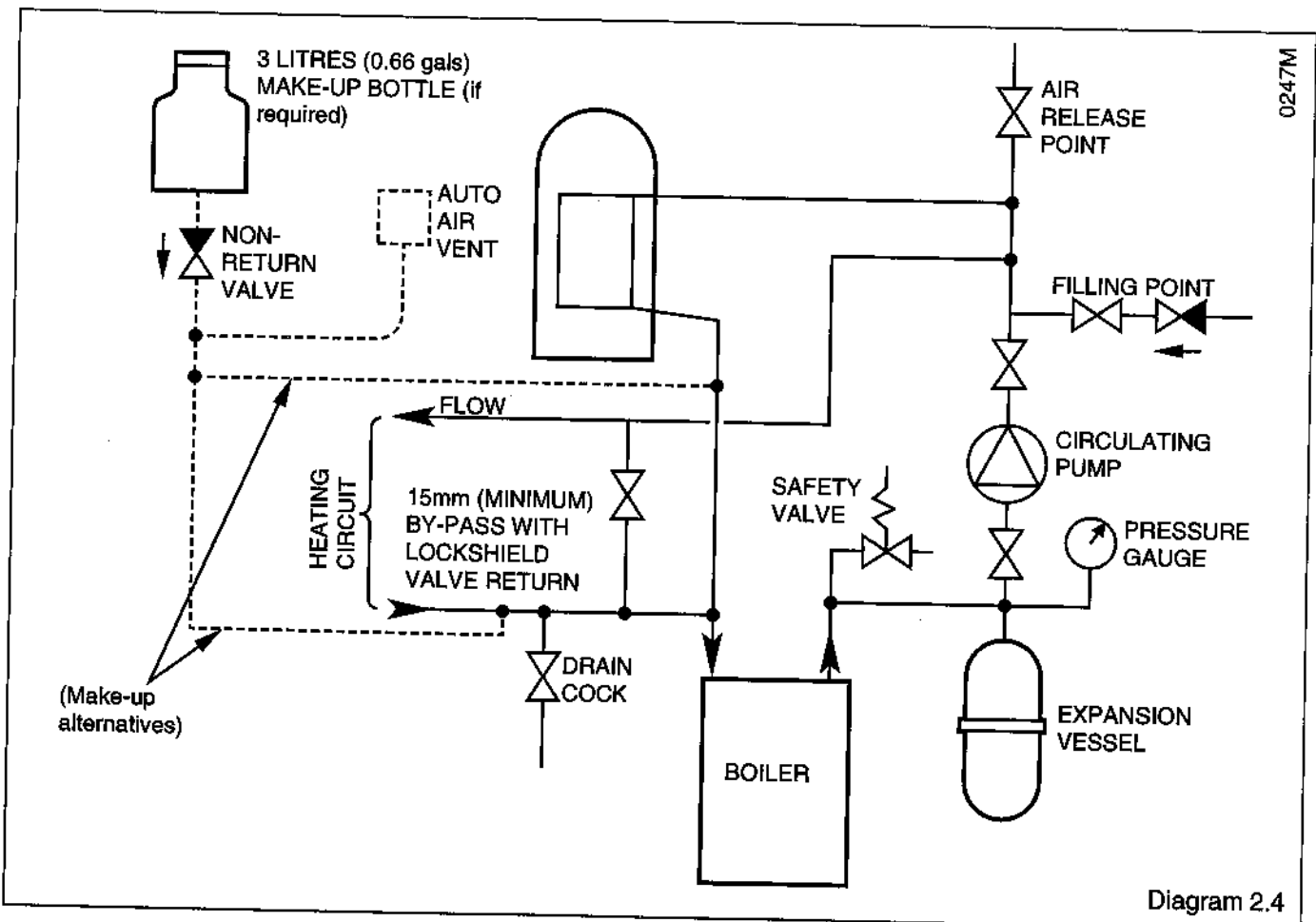
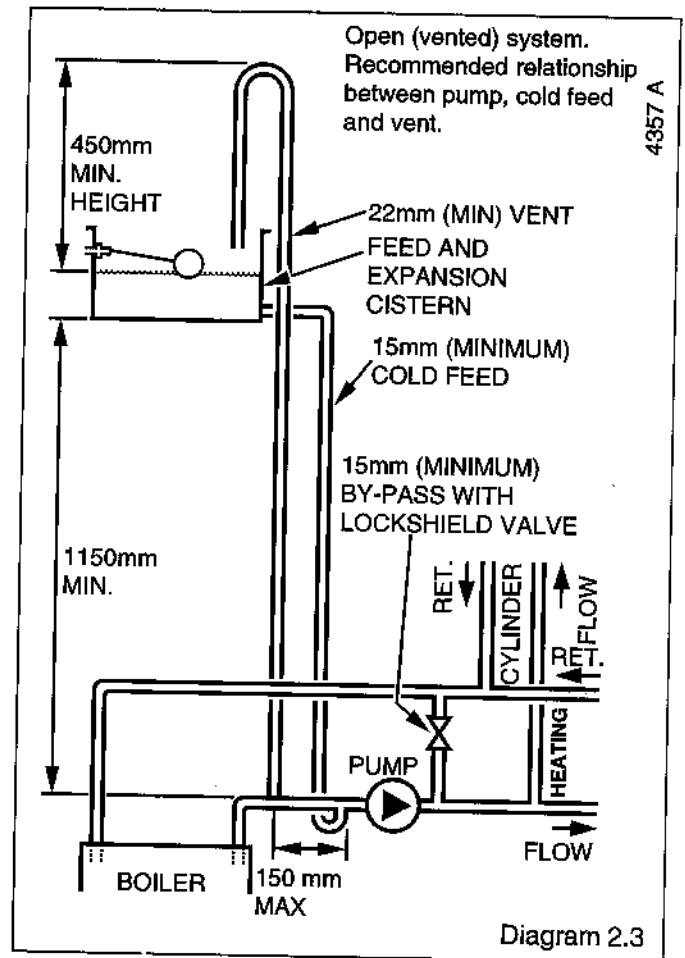

2.11 Expansion Vessel

A diaphragm type expansion vessel, conforming to the current issue of BS4814, see also BS7074 Part 1 and 2, must be connected at a point close to the inlet side of the circulating pump, see diagram 2.4, unless laid down differently by the manufacturer.

The expansion vessel volume depends on the total water system volume and the initial system design pressure. For any system an accurate calculation of vessel size is given in the current issue of BS7074 Part 1.

Example, for an initial system design pressure of 0.7bar, the minimum total vessel volume required is 0.063xTotal System volume.

Note, a higher initial design pressure requires a larger volume expansion vessel.

Guidance on vessel sizing is also given in the current issue of BS5449 and BS7074 Part 1.

The charge pressure must not be less than the static head of the system, that is, the height of the highest point of the system above the expansion vessel.

The water content of the boiler is given in the Data Table 1.

2.12 Pressure Gauge

A pressure gauge with a set pointer and covering at least 0 to 4bar (0 to 60lb/in²) shall be fitted permanently to the system in a position where it can be seen when filling the system.

2.13 Domestic Hot Water Cylinder

SINGLE FEED INDIRECT CYLINDERS ARE NOT SUITABLE.

The domestic hot water cylinder must be of the indirect coil type. It must be suitable for working at a gauge pressure of 0.35bar above the safety valve setting.

2.14 Water Makeup

Provision should be made for replacing water loss from the system using a make up bottle mounted in a position higher than the top point of the system, connected through a non-return valve to the return side of either the heating circuit or the domestic hot water cylinder.

Alternatively, provision for make up can be made using a filling loop.

2.15 Filling a Sealed Water System

Provision for filling the system at low level must be made. Three methods are shown in diagram 2.5. There must be no permanent connection of the mains water supply, even through a non-return valve.

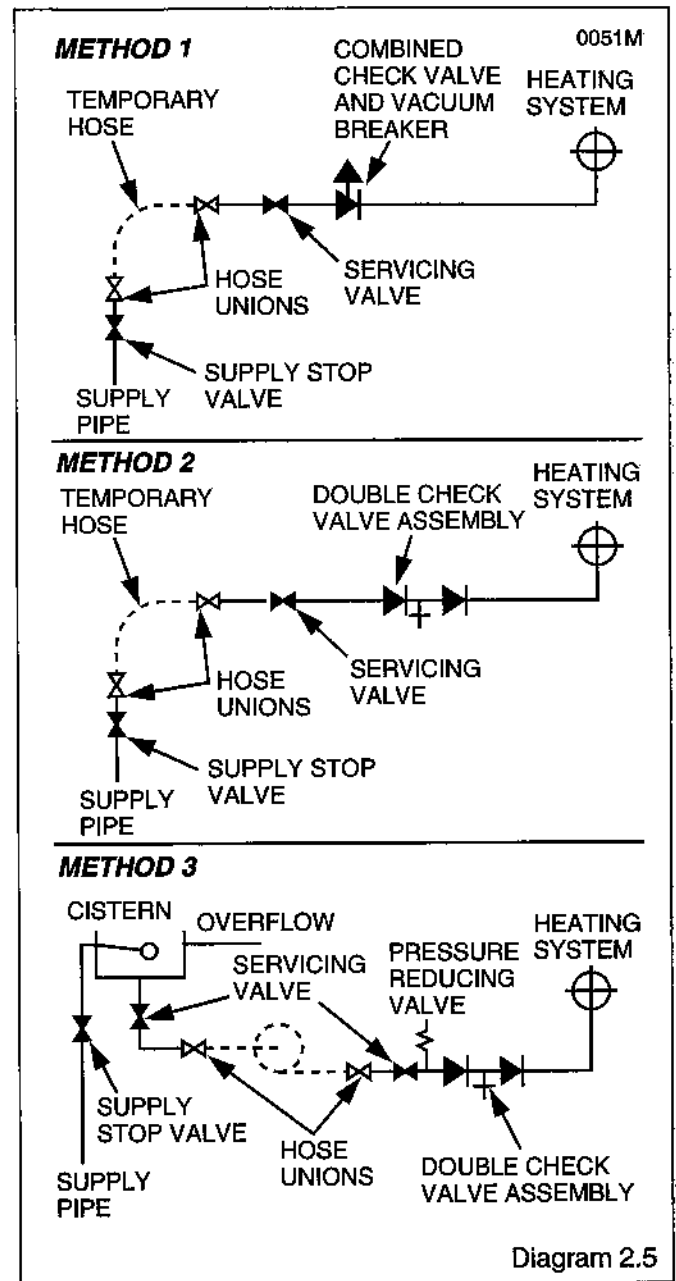

3 Boiler Location

NOTE:

The boiler may be installed in any room although particular attention is drawn to the requirements of the current issue of BS7671 with respect of the installation of a boiler in a room containing a bath or shower. Any electrical switch or boiler control using mains electricity should be so situated that it cannot be touched by a person using the bath or shower. The electrical provisions of the Building Standards (Scotland) Regulations apply to such installations in Scotland.

The boiler must be mounted on a flat wall which is sufficiently robust to take its total weight, see Data Table 1.

3.1 Boiler Clearances

The boiler must be positioned so that at least the minimum operational and servicing clearances are as shown in diagram 3.1.

Additional clearances may be required around the boiler for installation purposes, dependent upon site conditions.

3.2 Timber Frame Buildings

If the boiler is to be installed in a timber frame building it should be fitted in accordance with the Institute of Gas Engineers document IGE/UP/7/1998. If in doubt seek advice from the local gas undertaking or Hepworth Heating Ltd.

3.3 Room Ventilation

The boiler is room sealed, so when installed in a room or space a permanent air vent is not required.

3.4 Cupboard or Compartment Ventilation

Where the boiler is fitted in a cupboard or compartment, permanent high and low level ventilation must be provided. The ventilation areas required are given in Table 4.

Where the installation of the boiler will be in an unusual location, special procedures are necessary, refer to the current issue of BS6798 for guidance.

Make sure that the cupboard or compartment air vents are positioned to be clear of obstructions at all times.

A compartment used to enclose the boiler must be designed and constructed specifically for this purpose.

The doorway opening should be of a size to allow for easy removal of the boiler.

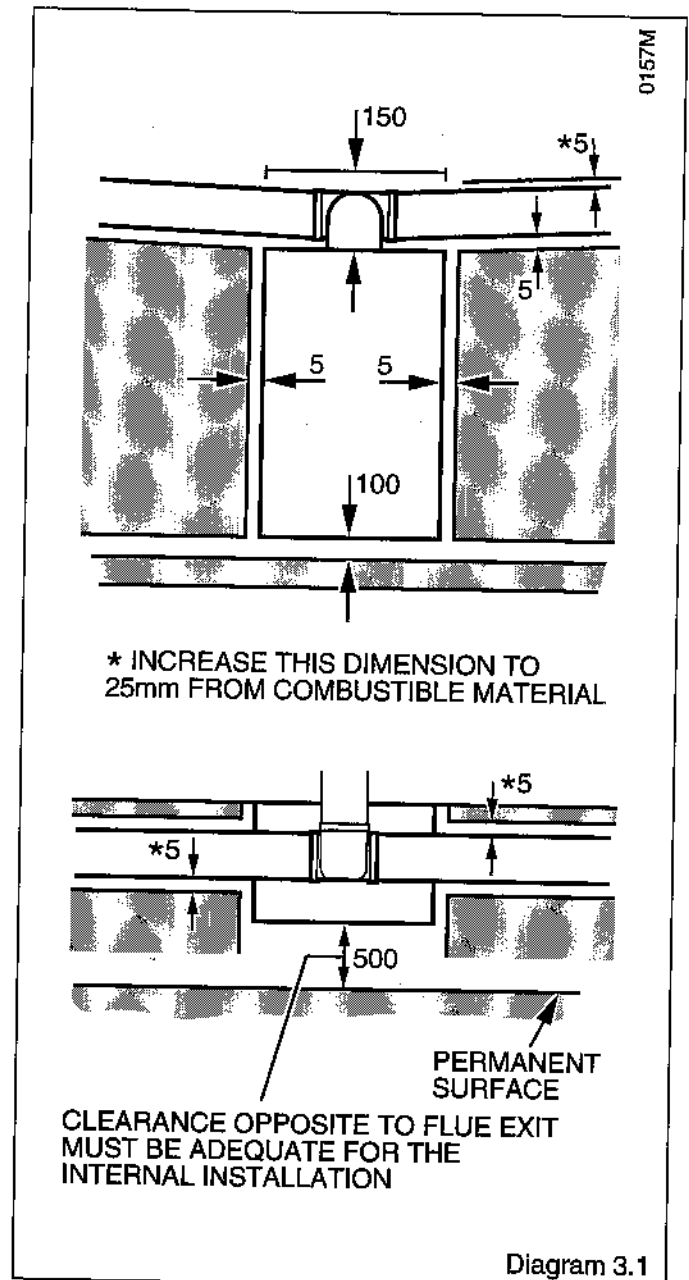

TABLE 4
ENERGYSAVER 50e

	high level		low level	
	cms	in ²	cms	in ²
Ventilation from room	153	23.8	153	23.8
Ventilation from outside	77	11.9	77	11.9

ENERGYSAVER 60e

	high level		low level	
	cms	in ²	cms	in ²
Ventilation from room	190	29.5	190	29.5
Ventilation from outside	92	14.3	92	14.3

4 Flue System

The flue must be installed in accordance with the current issue of BS5440 Part 1.

Important. The flue must be installed with a fall of 35mm per metre (2°) towards the boiler, see diagram 4.1.

It is of no advantage to exceed the angle of 2°, indeed sealing of the fan to the flue elbow may become more difficult as the angle is increased.

The air and flue duct connect to the top of the boiler using an elbow which can be positioned to the side or rear.

The rear and side flue assemblies are designed for internal installation, but if necessary, due to insufficient clearances (boiler/flue terminal location) they can be installed from the outside.

For a wall thickness up to 300mm the flue can be fully installed from the inside.

For a wall thickness over 300mm the external cut hole will need to be made good from the outside.

The standard flue is able to provide the duct lengths as shown in diagram 4.2 for a rear flue and diagram 4.3 for a side flue.

If a longer flue duct is required, do not extend the ductings. A 1, 2 or 3metre flue and terminal can be supplied.

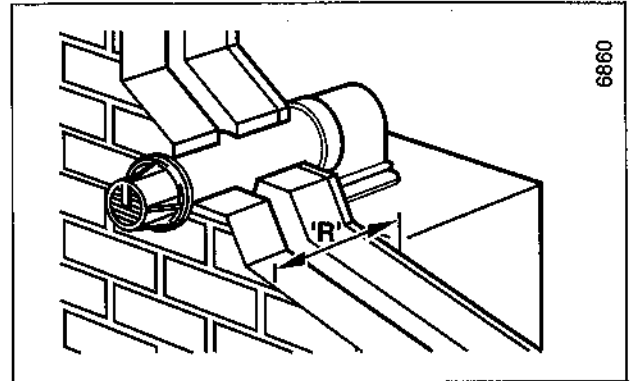

REAR FLUE LENGTHS

R = Wall Thickness

STD Flue pack	75mm to 442mm
1m Flue pack	75mm to 953mm
2m Flue pack	75mm to 1953mm
3m Flue pack	75mm to 2933mm

Diagram 4.2

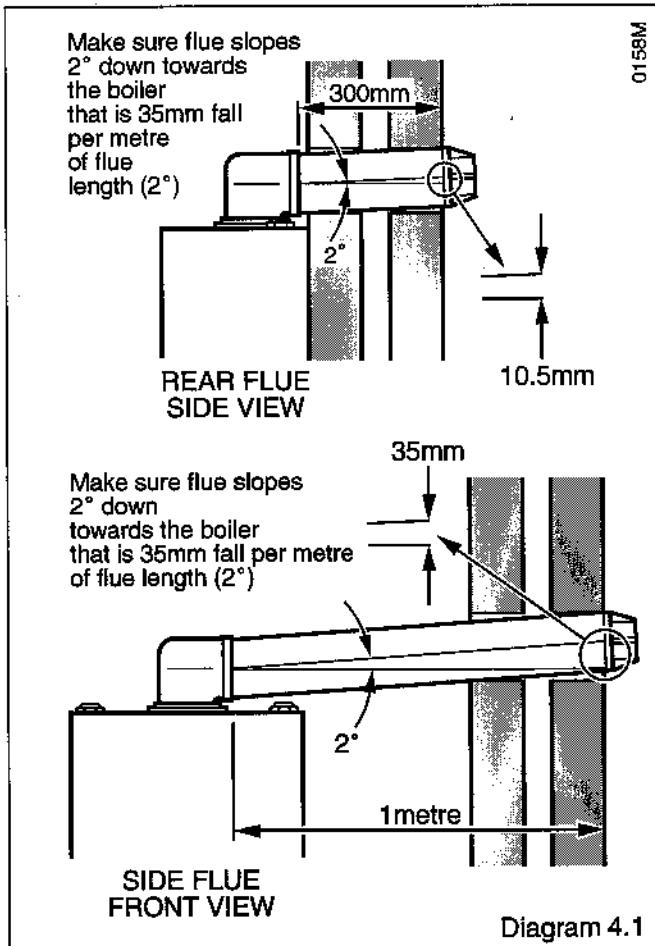
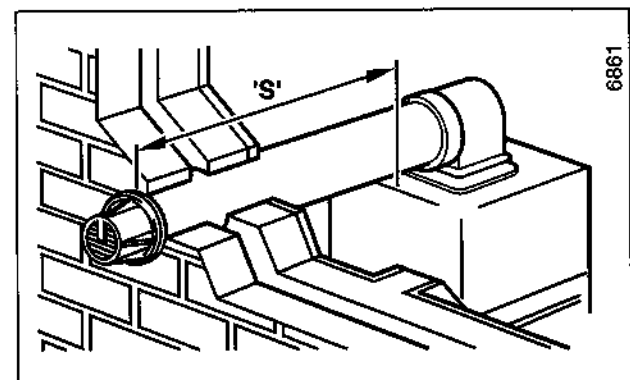

Diagram 4.1



SIDE FLUE LENGTHS

S = "External wall face" to "boiler casing"

STD Flue pack	80mm to 331mm
1m Flue pack	80mm to 841mm
2m Flue pack	80mm to 1841mm
3m Flue pack	80mm to 2821mm

Diagram 4.3

4.1 Terminal Position

The minimum acceptable spacings from the terminal to obstructions and ventilation openings are as shown in diagram 4.4.

The boiler must be installed so that the terminal is exposed to the external air.

It is important that the position of the terminal allows the passage of air across it at all times.

Note. The flue will produce a plume of condensation in cold weather, so special care must be taken in the siting of the flue terminal so as not to cause a nuisance to adjacent property.

Where the terminal is fitted within 600mm (24in) below plastic guttering an aluminium shield 1500mm (5ft) long should be fitted to the underside and immediately beneath the guttering or eaves.

Where the terminal is fitted within 450mm (18in) below eaves or painted guttering an aluminium shield 750mm (2ft6in) long should be fitted to the underside and immediately beneath the guttering or eaves.

4.2 Terminal Guard

A terminal guard is required if persons could come into contact with the terminal or the terminal could be subject to damage.

If a terminal guard is required, it must be positioned to provide a minimum of 50mm clearance from any part of the terminal and be central over the terminal, see diagram 4.4.

A suitable terminal guard can be obtained from:

Tower Flue Components Ltd.,
Morley Road,
Tonbridge,
Kent.
TN9 1RA

their reference CGD K3 BL

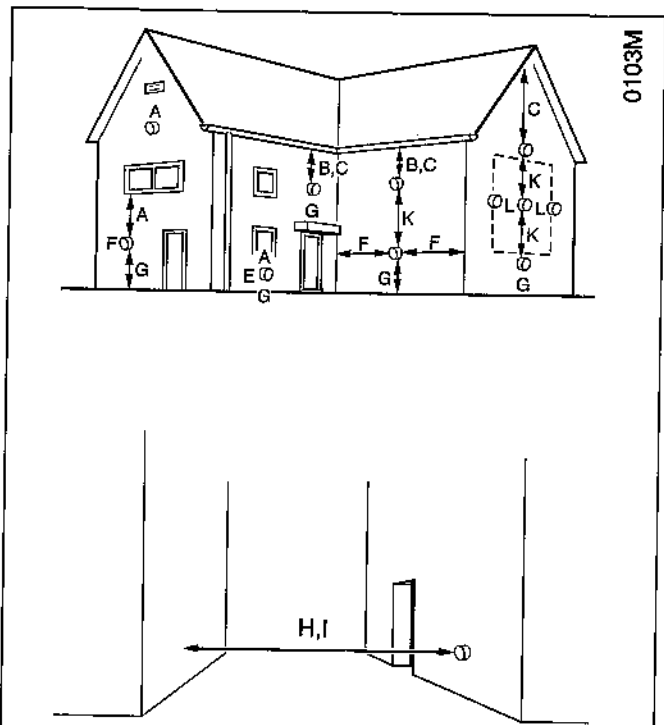

MINIMUM SITING DIMENSIONS
FOR FANNED FLUE
TERMINALS POSITION

MINIMUM
SPACING
in mm

A	DIRECTLY BELOW, ABOVE OR HORIZONTALLY TO AN OPENING, AIR BRICK, OPENING WINDOWS, AIR VENT OR ANY OTHER VENTILATION OPENING	300
B	BELOW GUTTER, DRAIN/SOIL PIPE	75
C	BELOW EAVES	200
E	FROM VERTICAL DRAIN PIPES AND SOIL PIPES	75
F	FROM INTERNAL OR EXTERNAL CORNERS	300
G	ABOVE ADJACENT GROUND OR BALCONY LEVEL	300
H	FROM A SURFACE FACING THE TERMINAL	600*
I	FACING TERMINALS	1200
K	VERTICAL FROM A TERMINAL	1500
L	HORIZONTALLY FROM A TERMINAL	300

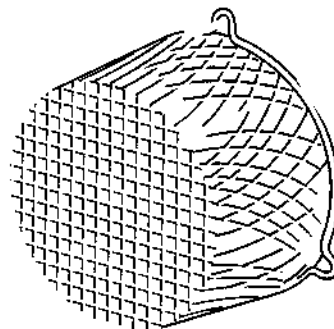

0161M

* It may be necessary to increase this dimension to prevent staining of adjacent walls depending on weather conditions.

Diagram 4.4

5 Preparation

5.1 Unpacking - refer to diagram 5.1.

Remove the wall template, top cardboard fitting,
Refer to diagram 5.1 for contents.

Lift off outer case front. Remove protective packing piece.
Remove the cover of the inner case, see diagram 5.3.

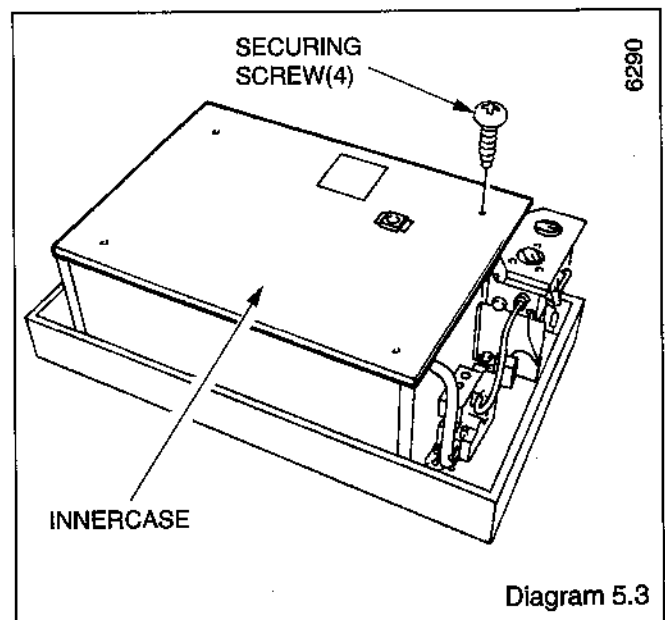
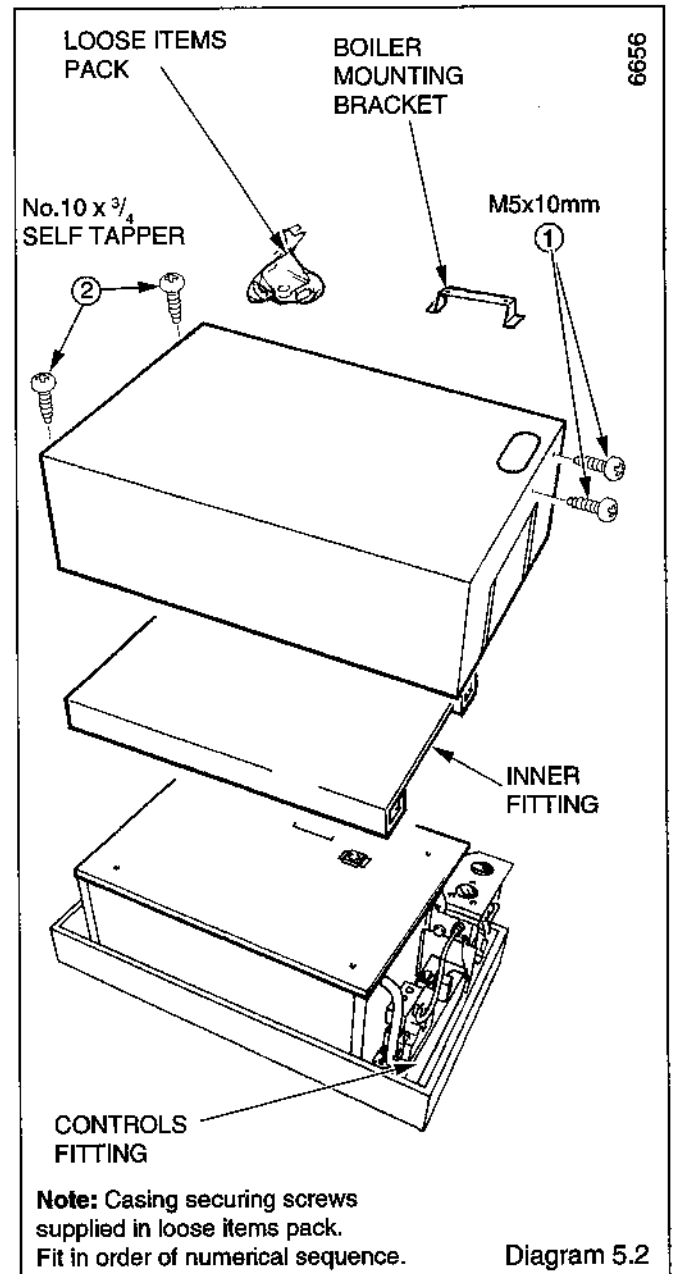
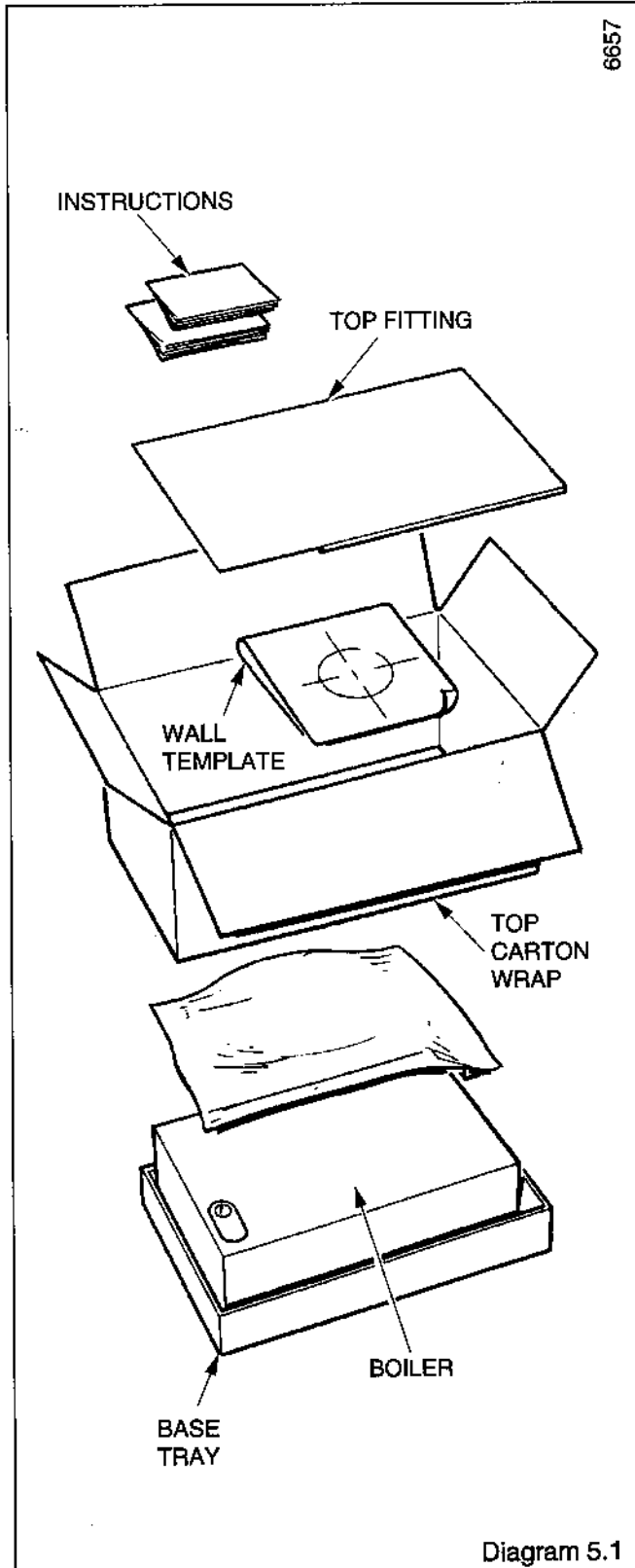

5 Preparation

5.2 Rear and Side Flue Application

Having selected the location and flue application, with due regard to the terminal position.

Take the template and temporarily position it on the wall, see diagram 5.4, making sure that the minimum clearances are maintained.

For a rear flue, mark the position of the flue as diagram 5.4.

For a side flue, extend the centre line horizontally (taking into account the required fall towards the boiler) left or right to the corner of the adjacent surface where the flue is required to exit to the outside.

Alternatively, the increase in the centre line height over a distance "x" is given by $H=0.035x$. Mark the position of the centre of the flue, as diagram 5.4.

5.3 Flue Hole Cutting

Having marked out the flue centre cut a hole for the flue, see diagram 5.5 for minimum core drill size for various wall thicknesses.

This will allow for the 35mm per metre (2°) fall towards the boiler.

Note: If required, an optional Wall Liner Kit, part No.900862, is available, complete with fixing instructions.

5.4 Wall Mounting Bracket

Reposition the template, making sure of dimensional alignment with the flue centre lines.

Mark the boiler securing screws and mounting plate position, see diagram 5.6.

Drill holes and plug, fit the securing screws, allowing sufficient clearance to accept the keyhole fixing brackets and secure the boiler mounting bracket to the wall.

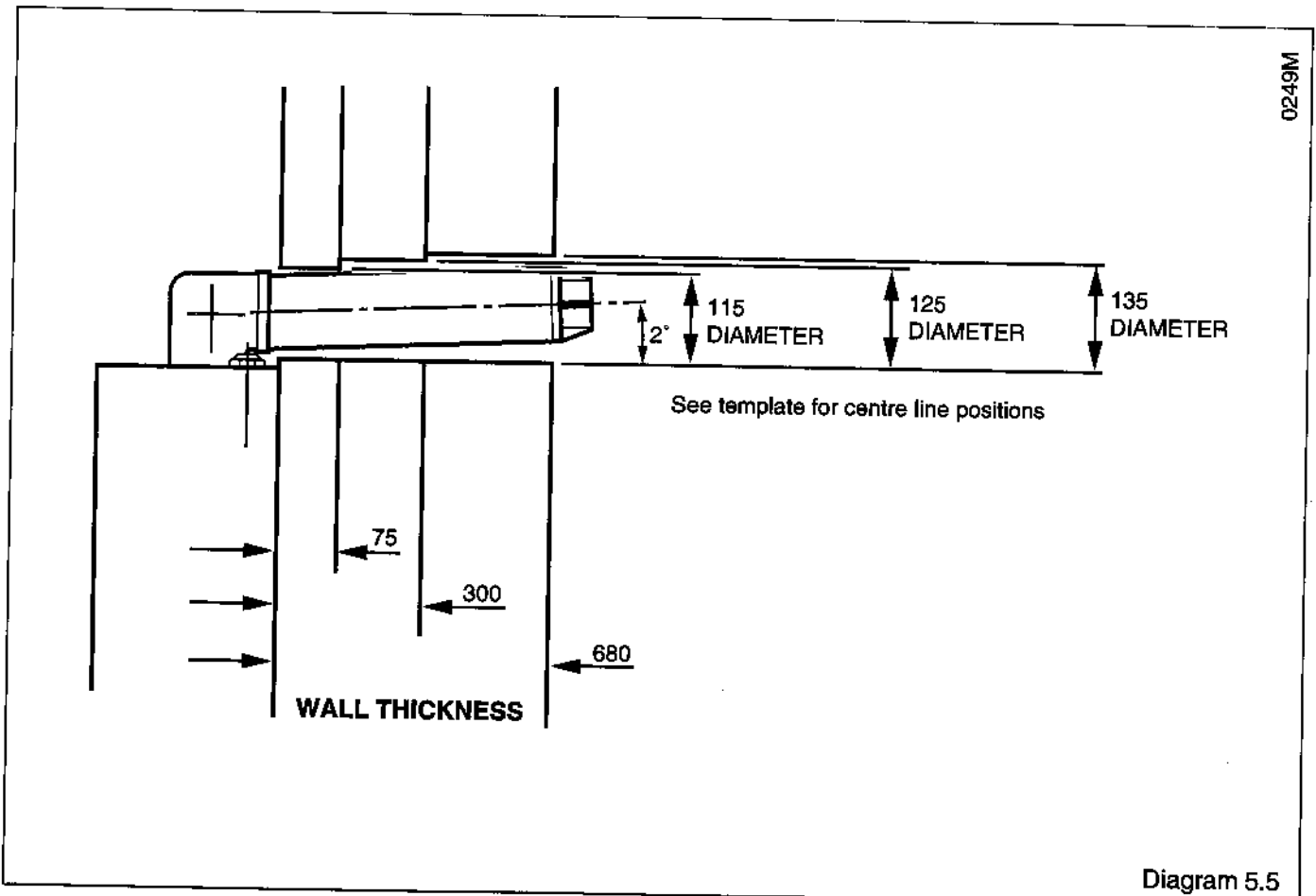
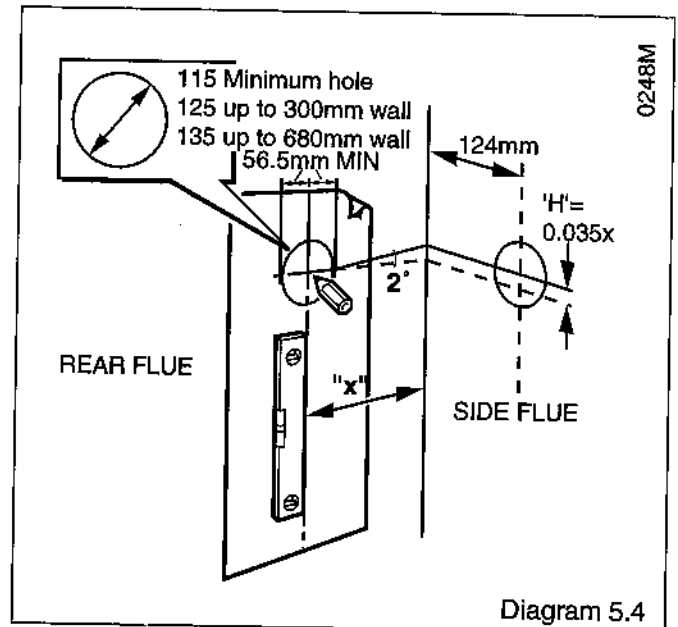

5 Preparation

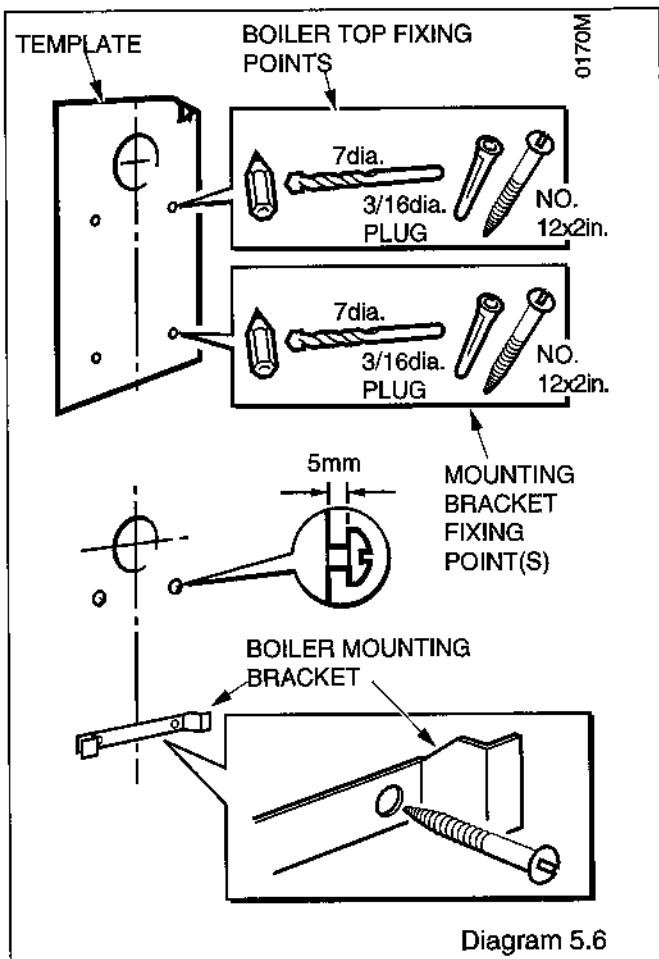

5.5 Boiler Preparation

Lift the boiler into position above the boiler mounting bracket, lowering the boiler into position at the same time locating the key hole slots of the boiler onto the securing screws, when located secure with the screws, see diagram 5.6.

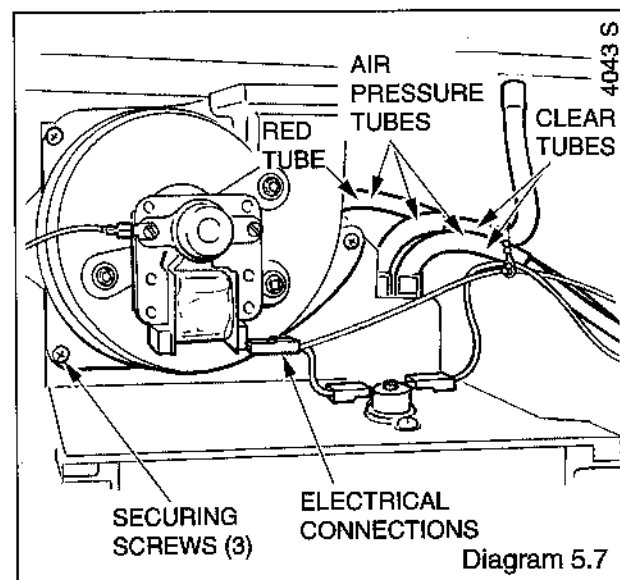

6 Water Connections

6 Water Connections

Make the water connections to the heating system, see diagram 6.1.

The boiler has compression connections with nuts and olives supplied loose in the fittings pack, to accept 28mm outside diameter copper tube to BS2871.

They may be reduced to 22mm provided that the system resistance does not exceed the chosen pump duty.

The right hand connection is the flow from the boiler.

6.1 Condensate Connection

The condensate drain connection is at the bottom right of the boiler.

The drain ends in a spigot which is suitable for push-fit 22mm ($\frac{9}{16}$ in) overflow pipe, for example, Hepworth, Polypipe, Uponor, Osma or Oracstar. If using Marley, Terrain or Hunter tubing, which is slightly larger, use silicone sealant provided in the fittings pack to make a leakproof joint to the drain connection on the boiler.

The condensate discharge pipe should have a fall of $2\frac{1}{2}^\circ$.

It is not necessary to provide air breaks or traps in the discharge pipe since the boiler has an integral trap and siphon.

The boiler is fitted with a safety device to prevent the boiler from working if the condensate pipe gets blocked by either ice or debris.

It is, therefore, recommended that any external condensate drain pipe is insulated to prevent freezing up.

Alternately, a larger diameter pipe can be used and insulated. The condensate pipe should be checked during any servicing and any debris removed.

Refer to the British Gas publication "Guidance Notes for the Installation of Domestic Condensing Boilers" for advice on the disposal of the boiler condensate.

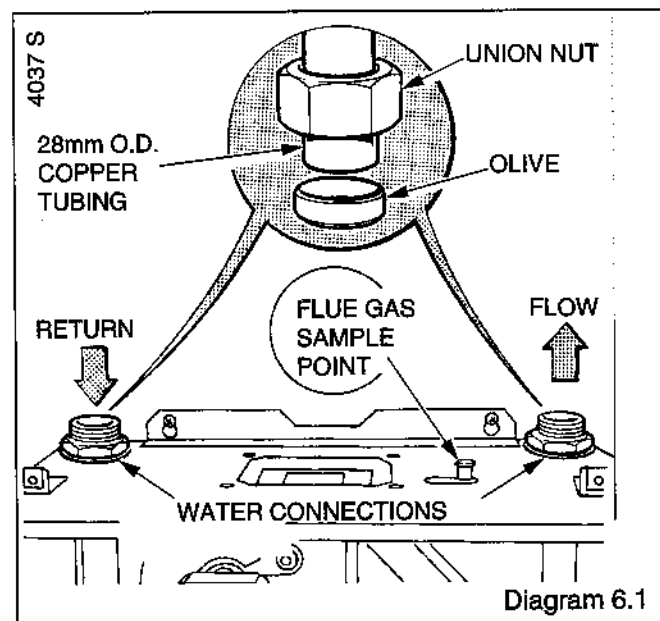

7 Flue Installation

7.1 Rear Flue

Mark and cut the air duct terminal assembly, see diagram 7.1 and the flue duct, diagram 7.2 to the lengths required, cutting square and removing any burrs.

Refer to diagram 7.3, mark through the holes in the flue elbow assembly and drill the duct as shown, making sure of the correct alignment of the "Top".

7.2 Side Flue

Mark and cut the air duct terminal assembly, see diagram 7.4 and flue duct, diagram 7.5 to the lengths required, cutting square and removing any burrs.

Refer to diagram 7.3 mark through the holes in the flue elbow assembly and drill the flue duct as shown, making sure of the correct alignment of the "Top".

7.3 Internal Flue Assembly

If access to the outside wall is not practical, the flue system can be installed from inside. Use of the optional wall liner kit recommended.

Apply sealant to the flue duct, locate into the air duct terminal, see diagram 7.6.

Apply sealant to the elbow spigot and then locate the flue and air terminal assembly to the flue elbow as shown in diagram 7.3, making sure of the alignment of the "Top".

Secure the air duct/terminal assembly to the flue elbow and the flue duct assembly with the two self tapping screws supplied in the loose items pack and then seal with the tape provided.

Place the flue assembly into the flue hole. Make sure that the flue terminal is correctly positioned and sticking out the correct distance from the outside wall face, see diagram 7.9.

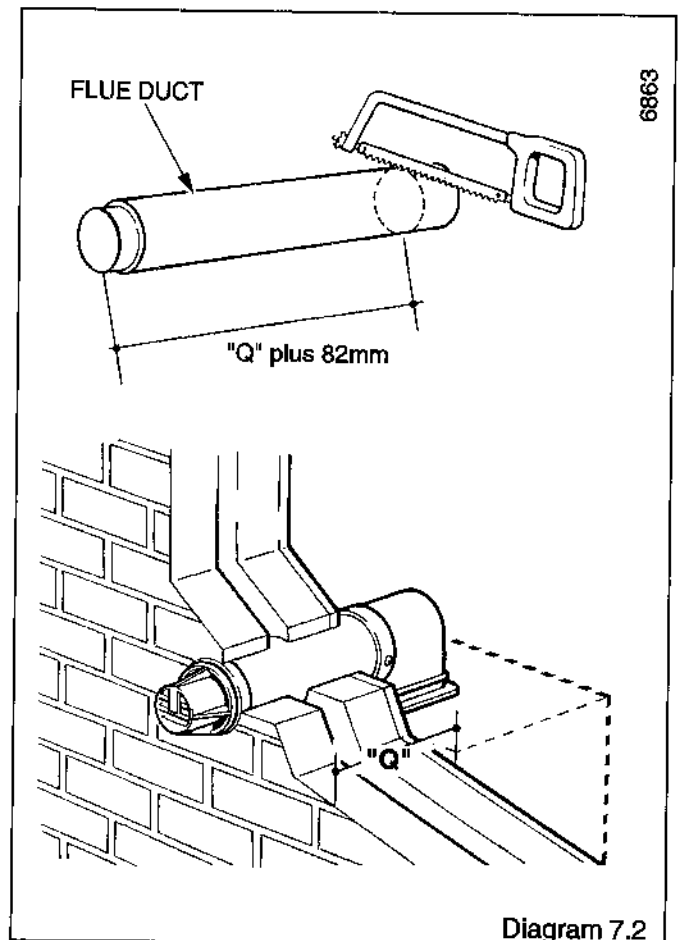
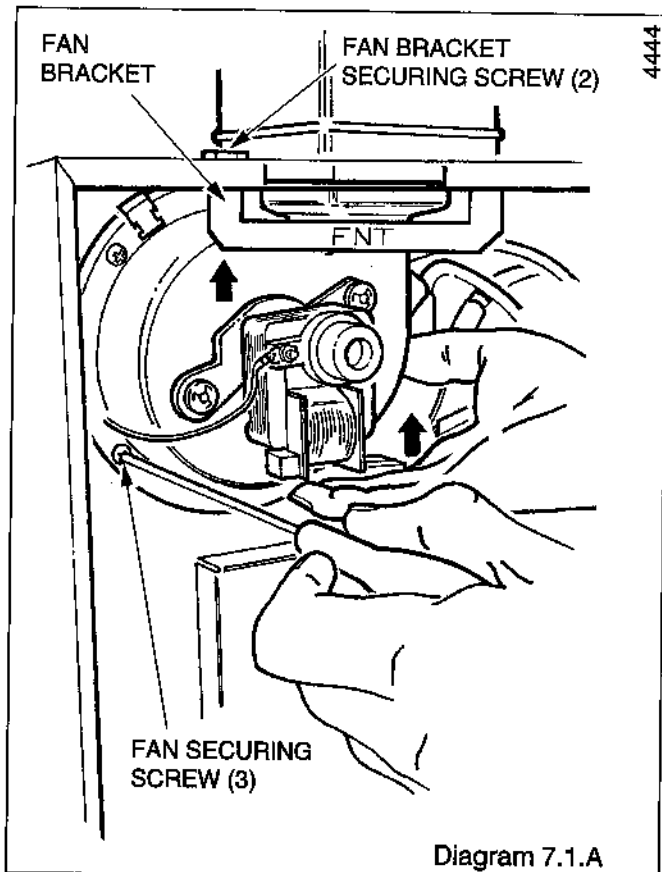
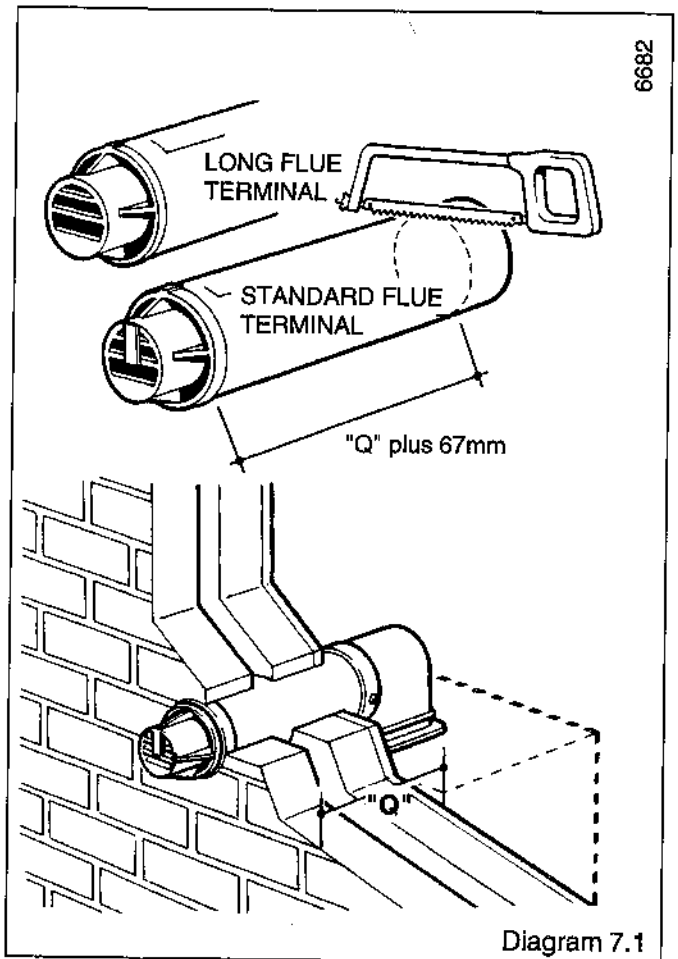

7 Flue Installation

7.4 External Flue Installation

Fit the air duct/terminal assembly into the flue elbow assembly as shown in diagram 7.3, making sure of correct terminal alignment of the "Top".

Mark the position of the air duct terminal assembly securing holes and drill two 2.8mm diameter holes through the air duct/terminal assembly.

Apply sealant to the flue duct and locate into air duct terminal, see diagram 7.6.

From outside, place the air duct/terminal assembly and flue duct into the flue hole. Make sure that the flue terminal is correctly positioned and sticking out the correct distance from the outside wall face, see diagram 7.9.

Apply sealant to the flue elbow spigot and then fit the flue and air duct terminal assembly as shown in diagram 7.3, make sure of the correct alignment of the "Top".

Secure the air duct terminal to the flue elbow with the two self tapping screws supplied in the loose items pack, then seal with the tape provided.

7.5 Flue Elbow

Fit the flue elbow gasket, from the fittings pack, to the casing top.

The two fan bracket securing screws should be loosened, but not removed, before slackening the three fan securing screws.

After fitting the flue elbow into the outlet of the fan, secure the flue elbow onto the top panel with the four M4x14 screws provided.

Then push upwards, making sure that the flue elbow spigot engages inside the fan outlet and compresses the gasket. Complete assembly by fully tightening the two fan bracket securing screws.

Finally tighten the three fan securing screws.

Fit the inner case door.

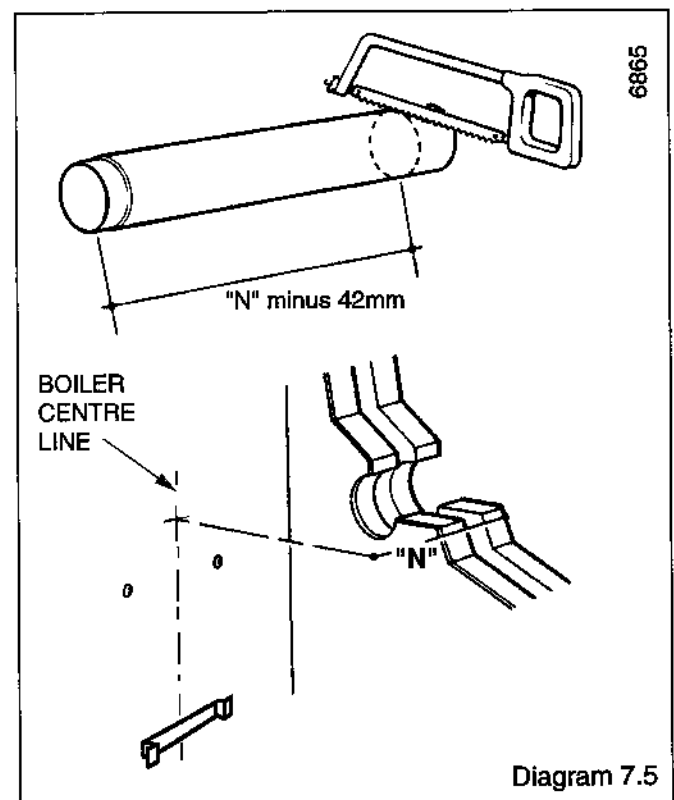
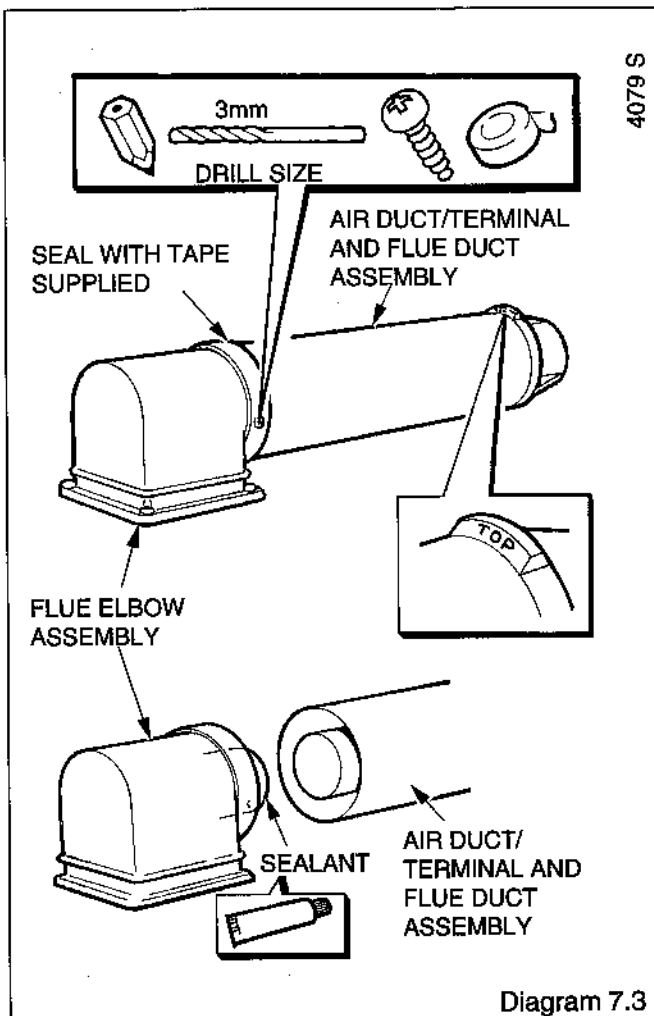
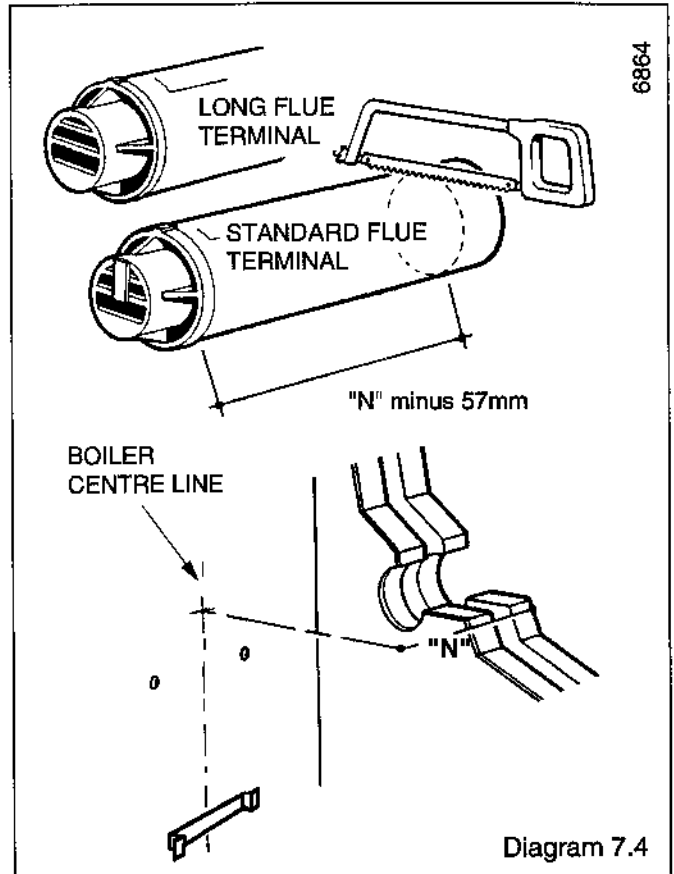

7 Flue Installation

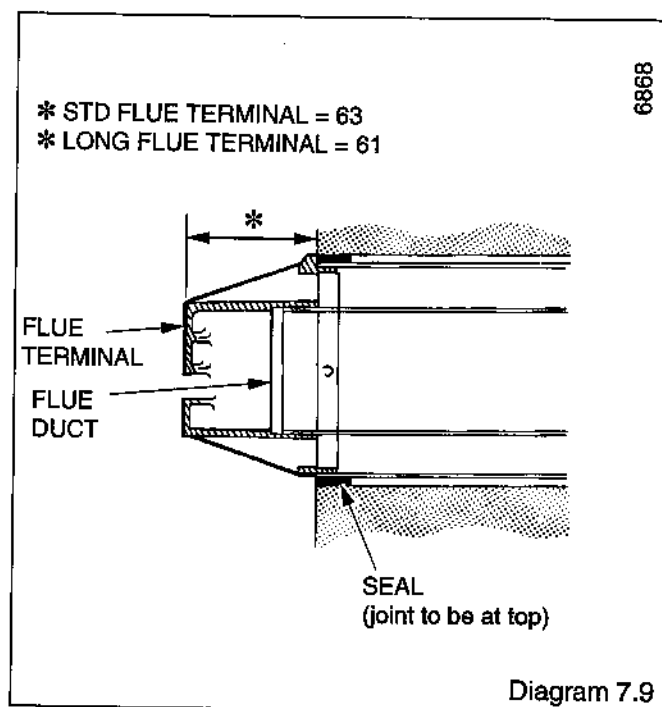
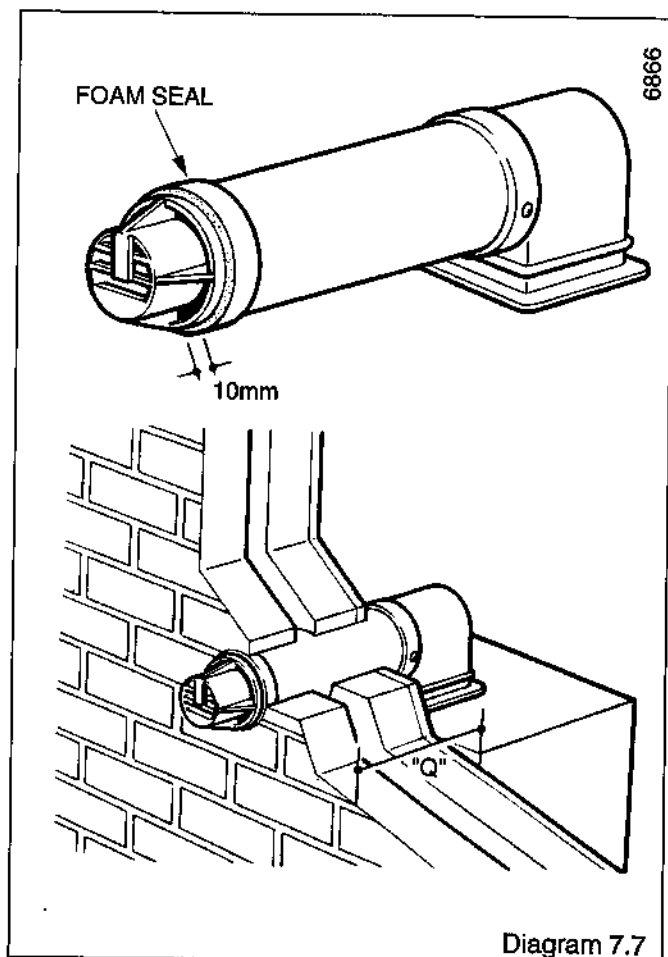
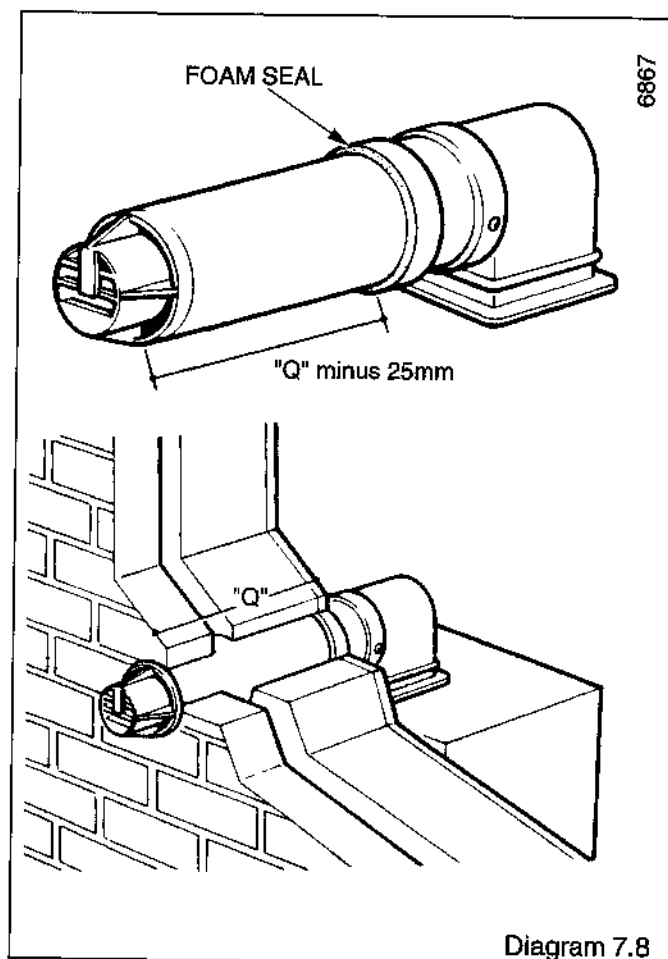
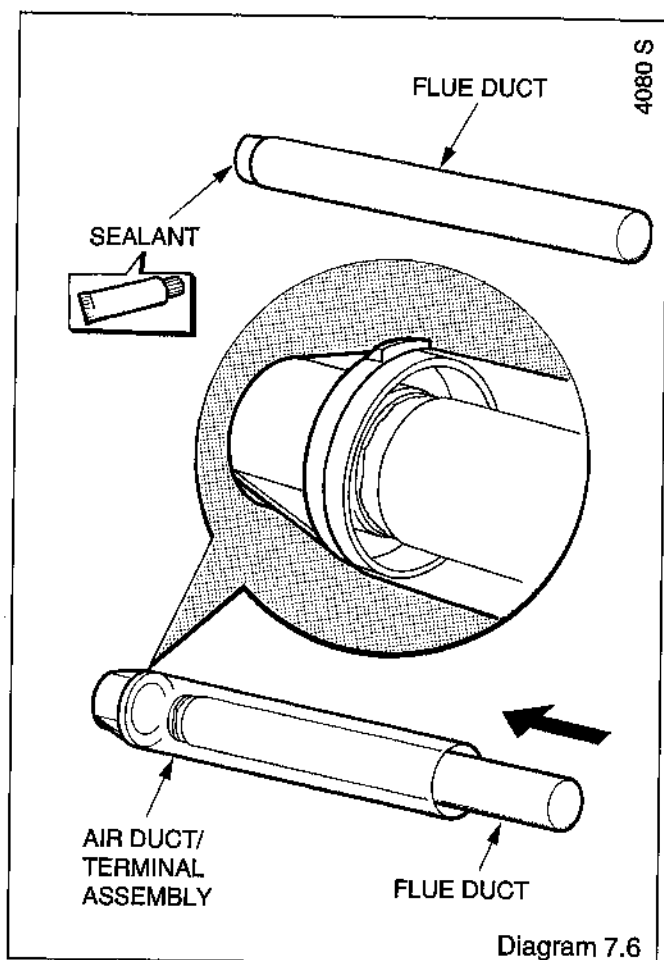

7.6 Wall Liner

If a wall liner is used :

For wall thicknesses up to 300mm fit the self adhesive seal to the air duct, see diagram 7.7, make sure the joint is on top.

For wall thicknesses over 300mm see diagram 7.8.

8 Gas Connection

Make the gas connection to the gas service cock, see diagram 8.1.

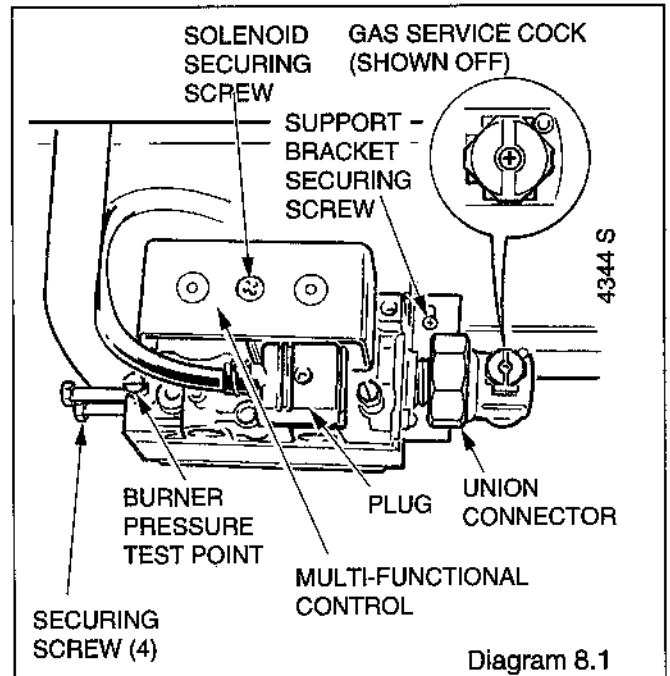

9 Electrical Connection

9 Electrical Connection

WARNING. This boiler must be earthed.

Remove the screws as diagram 9.1.

Pull the control box forwards to release from the rear slot, allow to pivot and place into position as shown in diagram 9.1.

Using PVC insulated cable to the current issue of BS6500 Table 16, and of suitable length, thread the cable through the small cable clamp and connect to the required terminals, see diagram 9.2.

Standard colours are, brown - live, blue - neutral, green and yellow - earth.

The mains cable outer insulation must not be cut back external to the cable clamp.

When making connections, make sure that the earth conductor is made of a greater length than the current carrying conductors, so that if the cable is strained the earth conductor would be the last to become disconnected.

It is essential that the polarity is correct.

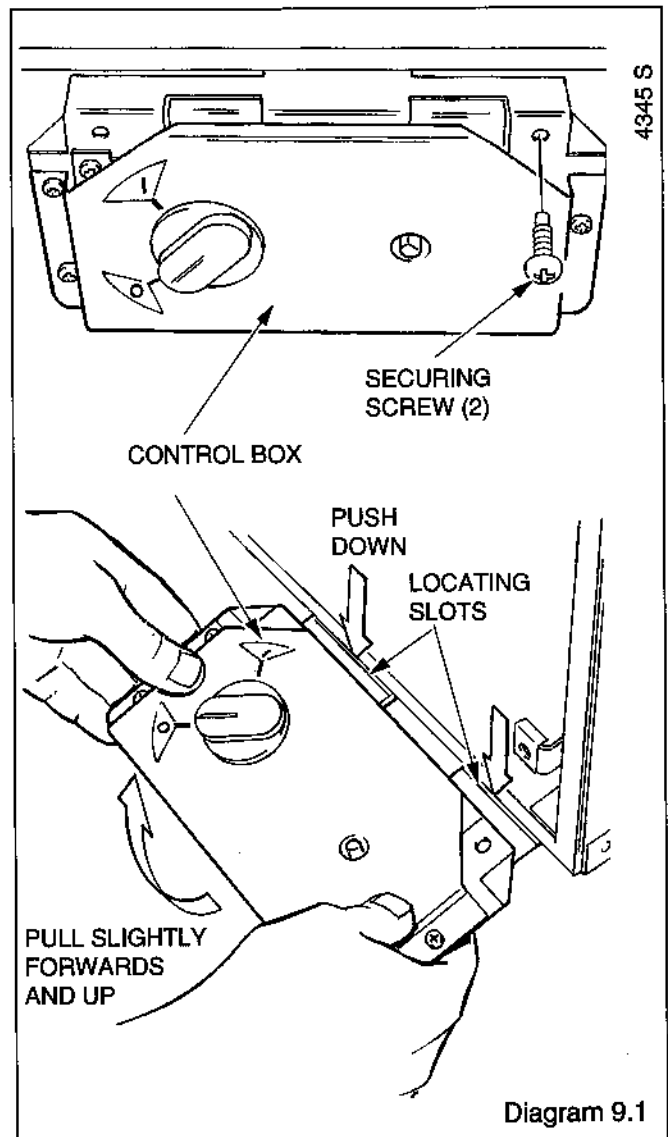

9 Electrical Connection

9.1 Pump and External Controls Connection

The pump must be connected directly to the control box, as shown in diagram 9.2.

Any external controls must only be connected to interrupt the Red Link between terminals 1 and SL.

Thread the cable(s) through the large cable clamp in the side of the control box.

9.2 Testing - Electrical

Checks to ensure electrical safety should be carried out by a competent person.

In the event of an electrical fault after installation of the system, preliminary system checks as below should be carried out.

1. Test resistance to earth of mains cable.
2. Test the earth continuity and short circuit of all cables.
3. Test the polarity of the mains.

The installer is requested to advise and give guidance to the user of the controls scheme used with the boiler.

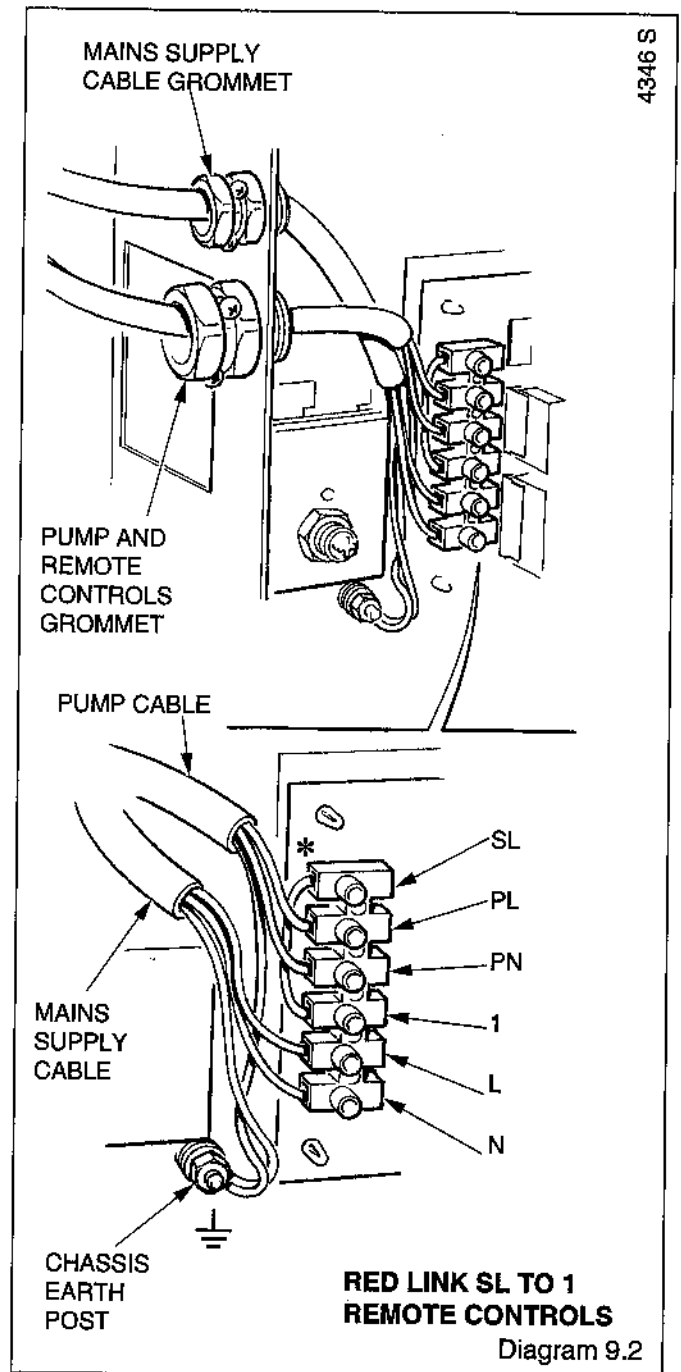

10 Commissioning

Please ensure the "Benchmark" logbook is completed and left with the user.

10.1 Preliminaries - All Systems

Commissioning should be carried out by a competent person in accordance with the current issue of BS6798.

Make sure that the system has been thoroughly flushed out with cold water without the pump in place.

Refit the pump, fill the system with water, making sure that all air is properly vented from the system and pump.

10.2 Sealed Water System

Fill the system until the pressure gauge registers 2.7bar (40lb/in²). Clear any air locks and check for leakage.

Check the operation of the safety valve, preferably by allowing the water pressure to rise until the valve lifts. This should be within +/-0.3bar (+/-4.3lb/in²), of the preset pressure. Where this is not possible a manual check should be carried out.

Release the cold water to initial design pressure.

10.3 Initial Lighting, Testing and Adjustment

WARNING. The multifunctional control, fan and control box work on MAINS voltage, terminals will become live.

Check that the mains electrical supply to the boiler is switched off and that the "ON/OFF" switch on the boiler is "OFF".

Turn on the supply at the gas service cock.

Loosen the burner pressure test point screw and fit a suitable pressure gauge, see diagram 8.1.

Turn the electrical supply to the boiler on and check that all remote control are calling for heat.

Turn the "ON/OFF" switch on the boiler to "ON".

The boiler lighting operation is now automatic.

The fan operates, followed by an ignition spark until the burner lights.

The burner will remain alight until switched off by the control thermostat or other remote control.

The automatic lighting sequence will operate again when heat is required.

10.4 Testing Gas

WARNING. Do not smoke or use any naked lights whilst doing the following.

With the boiler on carry on as follows:-

Test for gas soundness around the boiler gas components using a suitable leak detection fluid, in accordance with the current issue of BS6891.

Check the burner pressure at least 10 minutes after the burner has lit, refer to Data label.

If the main burner pressure requires adjustment, the adjustment nut is on top of the multifunctional control, see diagram 10.1.

Should any doubt exist about the gas rate, check it using the gas meter test dial and a stop watch, at least 10 minutes after the burner has lit, make sure that all other gas burning appliances and pilot lights are off, see Table 2.

Turn the "ON/OFF" switch to "OFF". Remove the pressure gauge from the test point and refit the screw, making sure a gas tight seal is made.

When the "ON/OFF" switch is turned to "OFF", by hand, wait at least 30 seconds before turning "ON" again.

There may be an initial smell given off from the boiler when new, this is quite normal and it will disappear after a short period of time.

Refit the electrical controls box.

10.5 Heating System

Check that all remote controls are calling for heat.

Allow the system to reach maximum temperature and examine for water leaks. The boiler should then be turned off and the system drained off as rapidly as possible whilst still hot.

Refill the system, vent and again check for water soundness.

For sealed water systems adjust to initial design pressure. The set pointer on the pressure gauge should be set to coincide with the indicating pointer.

The overrun thermostat will keep the pump running when the boiler shuts down, so long as the temperature within the boiler is above a predetermined level.

When commissioning the system the boiler should be fired with the bypass fully closed on full service, that is, central heating and domestic hot water.

The system should then be balanced, adjusting the pump and lockshield valve as necessary to achieve the flow rates, refer to Section 2.4.

Having achieved a satisfactory condition, operate the boiler with the bypass closed on minimum load, normally central heating only with one radiator operating in the main living area. The valve should be opened gradually to achieve the appropriate flow rate as quoted in Section 2.4. If necessary readjust the pump.

Under NO circumstances should this valve be left in the FULLY closed position.

10.6 Condensate Check

After 30 minutes of running, turn the boiler off and remove the inner case.

Check that there are no condensate leaks from the fan outlet/flue elbow or fan inlet/flue hood joints. Also check for leaks from the condensate drainage system.

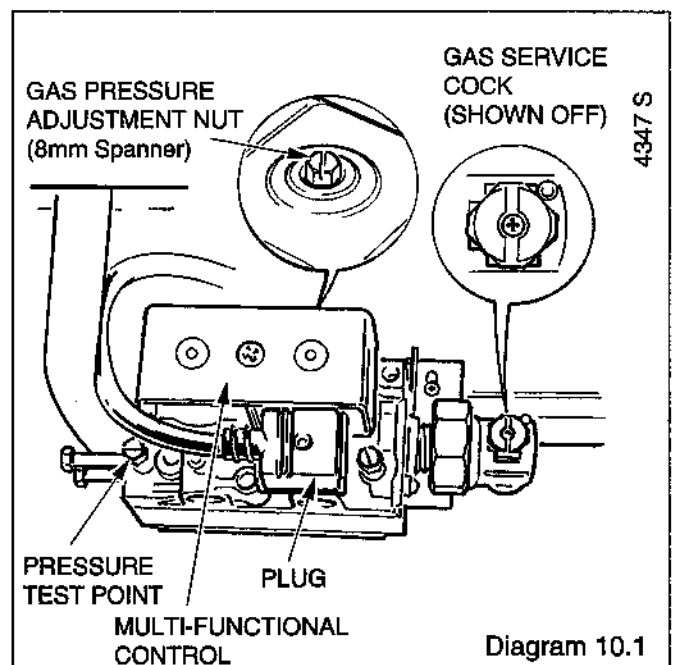

10.7 Operational Checks

Switch the "ON/OFF" switch to "ON" and any system controls to their required settings.

Do not attempt to adjust the thermostat calibration screw.

Operate the boiler again on full service and check that the balancing is satisfactory, making further adjustments as necessary to the system, radiator valves and bypass.

There must be no pumping over of water or entry of air at the vent above the feed and expansion cistern.

If thermostatic radiator valves are fitted care must be taken to make sure that there is an adequate flow rate through the boiler and bypass when the valves are closed. For guidance on the use of thermostatic radiator valves refer to the current issue of BS7478 and the British Gas publication "Guidance Notes for Installation of Domestic Condensing Boilers".

To check the operation of the flame supervision device, with the burner alight, turn gas service cock to "Off", the burner will go out. There will be one attempt to relight, indicated by a five to ten seconds ignition phase.

Wait for 30 seconds.

Turn the gas service cock "ON" and the burner should NOT relight.

Switch the "ON/OFF" switch to "OFF" and then "ON" again the burner WILL now relight.

Refit the outer case, see diagram 5.2 and secure the case with the screws from the fittings pack.

11 User Information

11 User Information

Instruct and demonstrate the efficient and safe operation of the boiler, heating system and if fitted, the domestic hot water system.

Advise the user that, like all condensing boilers this appliance will produce a plume of condensation from the flue terminal in cool weather. This is due to the high efficiency and hence low flue gas temperature of the boiler.

Advise the user that if the boiler should fail to come on at the required time, turn the boiler "OFF" and then "ON" again, the ignition system will be reset and the boiler light.

Advise the user of the precautions necessary to prevent damage to the system and building in the event of the heating system being out of use during frost and freezing conditions.

Advise the user, that to ensure the continued efficient and safe operation of the boiler it is recommended that it is checked and serviced at regular intervals. The frequency of servicing will depend upon the particular installation conditions and usage, but in general once a year should be enough.

Draw attention, if applicable, to the current issue of the Gas Safety (Installation and Use) Regulations, Section 35, which imposes a duty of care on all persons who let out any property containing a gas appliance.

It is the law that servicing is carried out by a competent person.

Reminder - Leave these instructions and the "Benchmark" logbook with the user.

REMEMBER, When replacing a part on this appliance, use only spare parts that you can be assured conform to the safety and performance specification that we require. Do not use reconditioned or copy parts that have not been clearly authorised by Hepworth Heating Ltd.

Notes

To ensure the continued efficient and safe operation of the boiler it is recommended that it is checked and serviced at regular intervals. The frequency of servicing will depend upon the particular installation and usage, but in general once a year should be enough.

It is the law that any servicing is carried out by a competent person.

Note, to get a products of combustion reading use the connection on top of the boiler, see diagram 6.1.

Should the gas pressure need adjusting refer to Section 10.4.

Isolate the boiler from the electrical supply.

Before starting a service, remove the casing, refer to diagram 5.1.

Turn the gas supply off at the gas service cock, see diagram 8.1.

Unless stated otherwise, parts removed for servicing should be replaced in the reverse order to removal.

After completing a service of gas carrying parts, ALWAYS test for gas soundness and carryout functional check of controls.

Check for condensate leaks at fan outlet/flue elbow and fan inlet/flue hood joints.

It should be noted that the burner is water cooled and a system drain down is necessary if the burner is to be removed.

12.1 Heat Exchanger Cleaning

Remove the inner case cover, see diagram 5.3.

Remove the bypass heat shield, see diagram 12.1.

Note, the flue hood top will "spring" up.

Disconnect the fan air pressure tubes, combustion sampling tube, electrical connections and remove the three fan securing screws, fan and the flue hood.

Note, on reassembly it is suggested that the two top securing screws for the bypass heat shield and the flue hood be partially engaged before fitting of the bypass heat shield, see diagram 12.3.

Carefully remove the combustion chamber front panel, see diagram 12.4.

Remove the loose baffle from the condensing section, see diagram 12.5.

When replacing note that it is marked "Front".

Place a container under condensate drain trap, see diagram 12.8, and remove red cap.

Flush loose debris from secondary heat exchanger with water poured from above, and allow the water to drain through the flexible condensate tube at the right hand side of the heat exchanger into the container.

Check that this tube is not partially blocked and the water runs freely.

If there is any build up of debris in the condensate trap, the trap should be removed and flushed out.

Important. With use a white oxide coating will form on the aluminium parts - this should only be removed if the coating is blocking the gaps between the fins.

When cleaning take care that water does not overflow the condensate catchment tray.

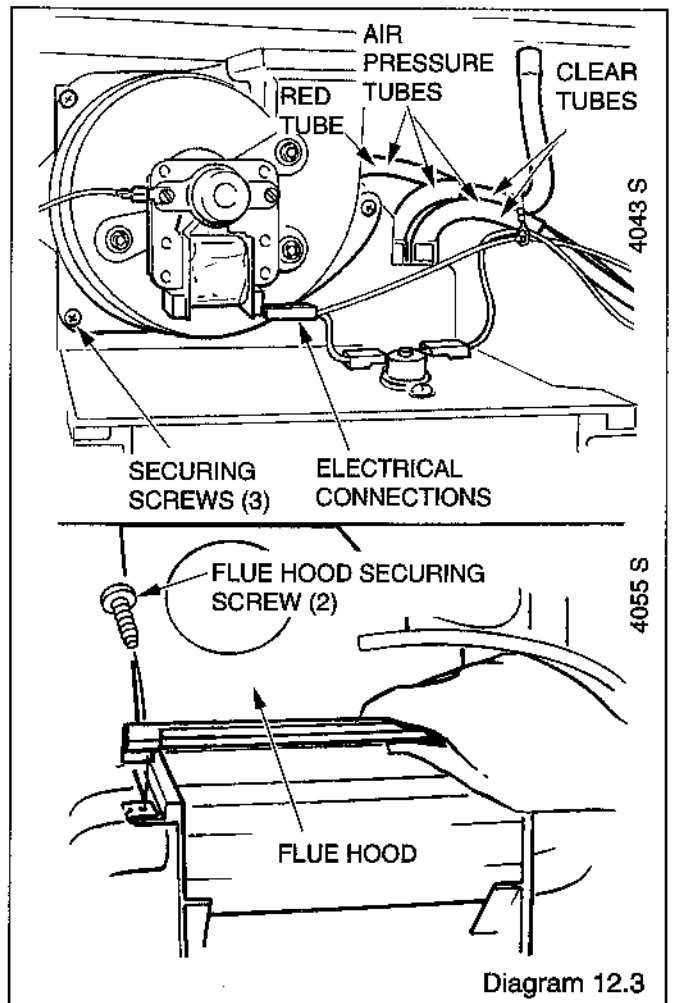
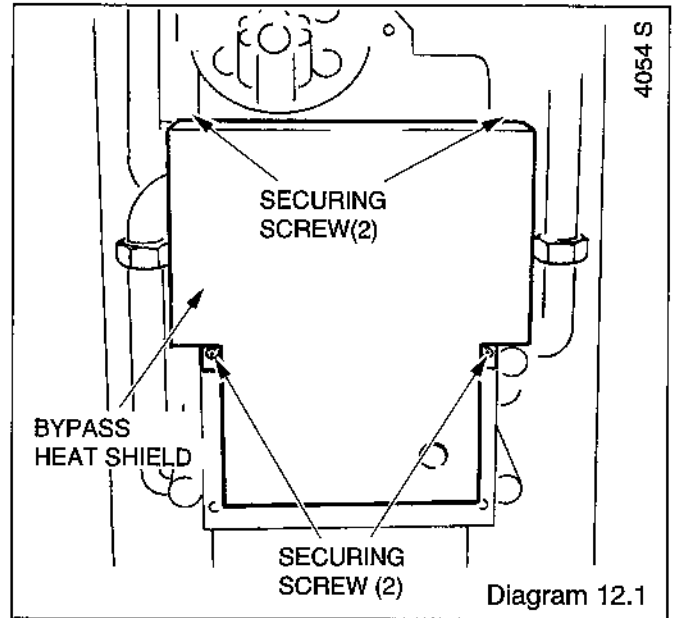

Place a sheet of paper over the burner, see diagram 12.6.

Clean the primary heat exchanger, with a suitable soft brush, see diagram 12.6.

Brush from front to back NOT left to right.

Do not use a brush with metallic bristles.

Remove the paper and any debris.

12.2 Burner

Clean the fins of the burner with a suitable brush, any debris can be allowed to fall into the mixing chamber.

Do not use a brush with metallic bristles.

Note, the burner is water cooled and a system drain down is required if removing.

12.3 Injector

Remove the injector by releasing the three screws at the injector manifold burner box, the two screws at the inner case base sealing plate, diagram 12.7 and the four screws at the multifunctional valve, see diagram 8.1.

Make sure that the "O" ring is in place in the flanged connection when refitting.

Clean the holes by blowing through.

Do not use a wire or sharp instrument on the holes.

12.4 Spark Electrode

Remove the silicone sleeving and disconnect the ignition/sensing lead, see diagram 12.9.

Remove the two securing screws.

Withdraw the electrode taking care not to damage the insulation material. Inspect and clean taking care not to damage the ceramic body.

When replacing make sure that the spark gap is as shown.

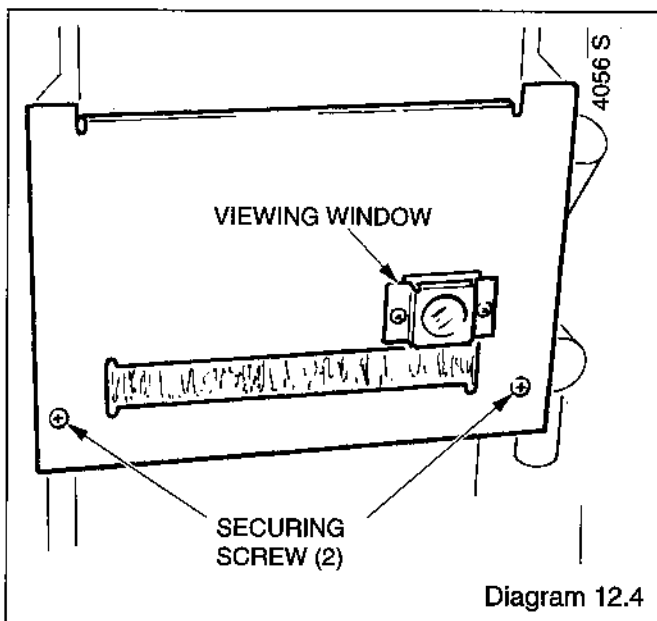

Diagram 12.4

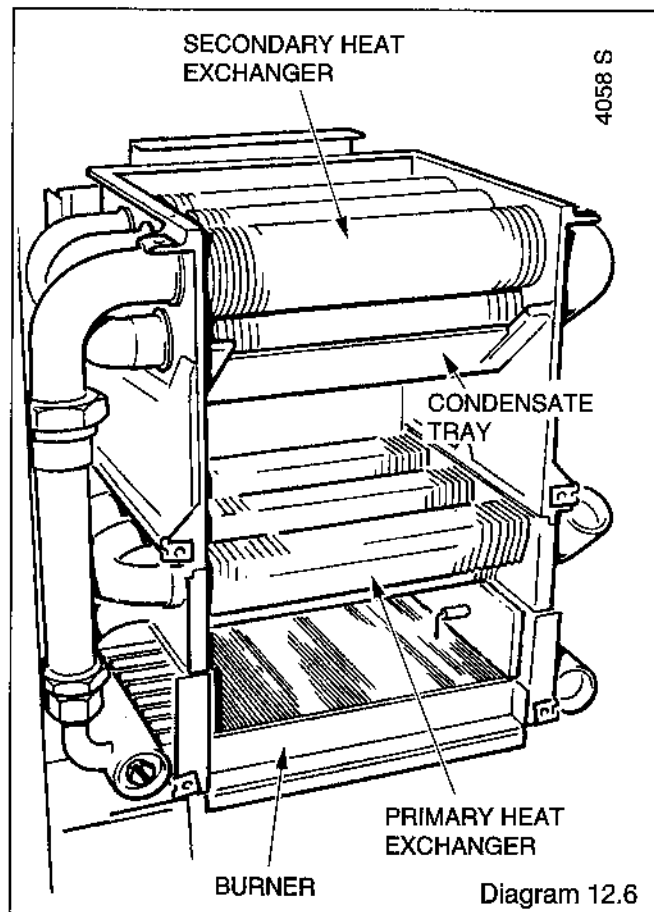

Diagram 12.6

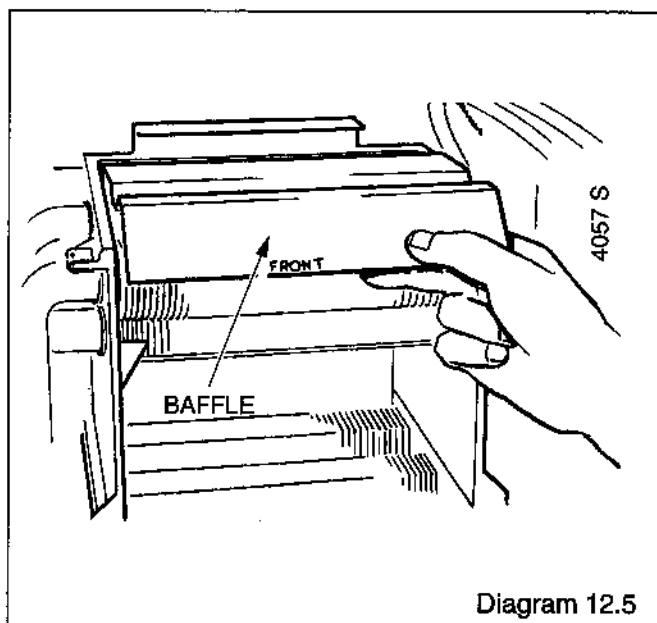

Diagram 12.5

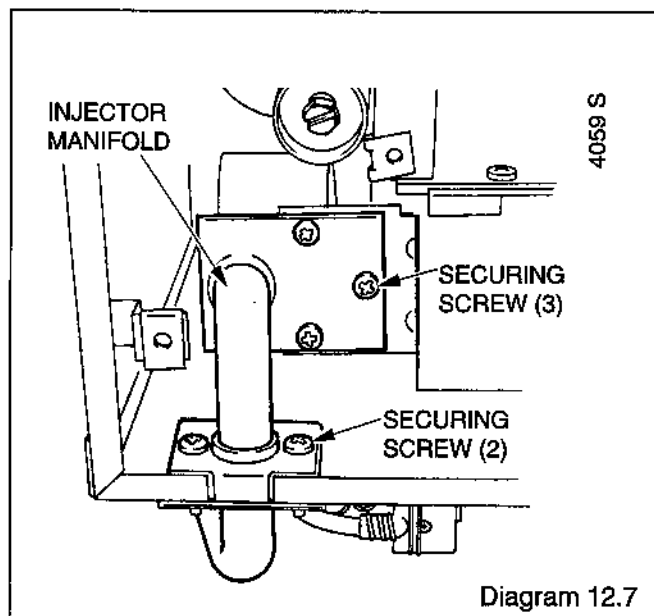

Diagram 12.7

12.5 Condensate Drain

Remove the cap at the base of the condensate drain trap, see diagram 12.8 and carefully flush through, from the condensate collecting tray, diagram 12.6 taking care not to allow any water to overflow the tray.

When refitting the cap make sure a water tight seal is made.

12.6 Operational Checks

After completing a service, before fitting the casing, check the inner case seal to make sure that it is good condition, renew if necessary.

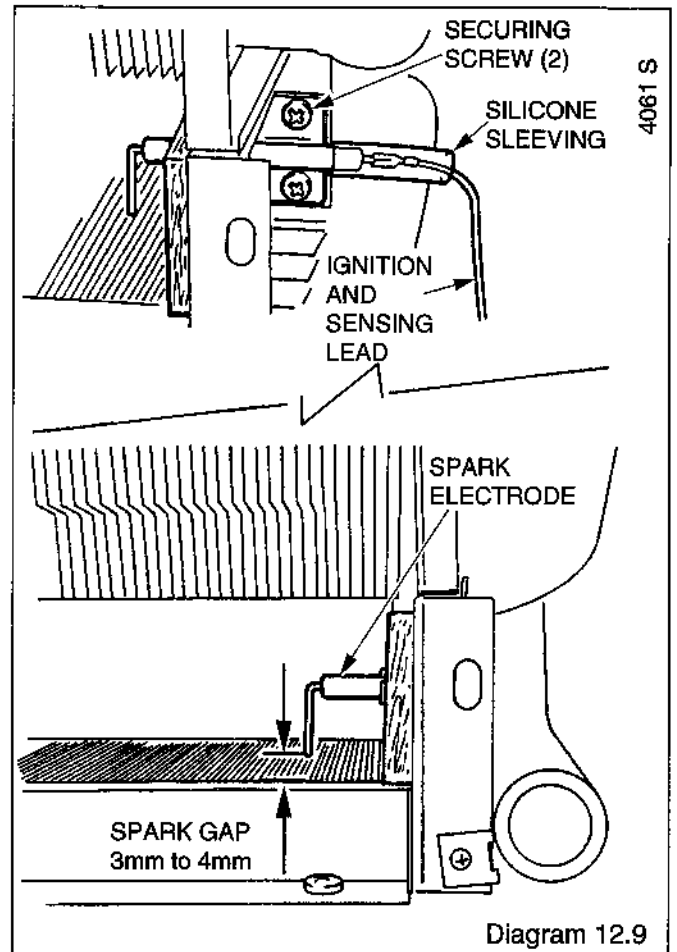
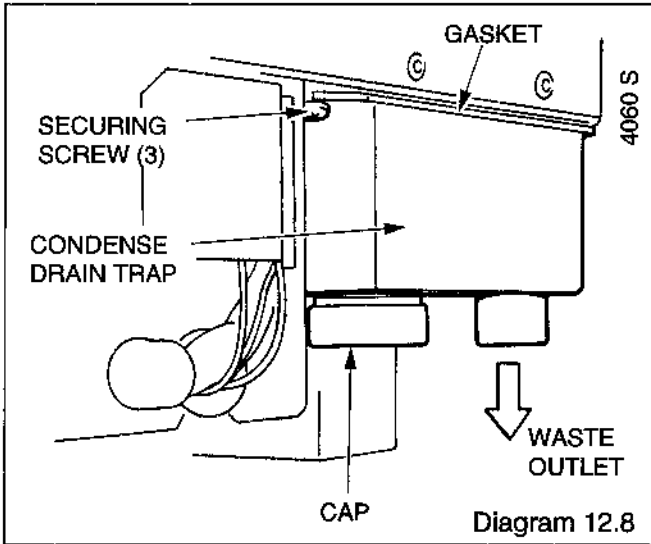

13 Fault Finding

13.1 Electrical

Important. On completion of the Service/Fault Finding task which has required the breaking and remaking of the electrical connections the earth continuity, polarity, short circuit and resistance to earth checks must be done again, using a suitable multimeter.

Refer to Fault Finding diagram 13.3, Wiring, diagram 13.4 and Functional Flow, diagram 13.5.

13.2 Electrical Supply Failure

Failure of the electrical supply will cause the burner to go out.

Operation will normally resume on restoration of the electrical supply. If the boiler does not relight after an electrical supply failure the overheat device may need resetting.

To reset, press the reset button, on the underside of the boiler, see diagram 13.1.

If the cutoff operates at any other time press the reset button and the burner should relight. If the fault persists, refer to Fault Finding Chart.

There is a further cutoff, mounted on the flue hood, see diagram 13.2, which may also need resetting.

13.3 Condensate Sensor

Refer to Fault Finding Chart.

The boiler is fitted with a safety device to prevent the boiler from working if the condensate drain pipe gets blocked.

Remove the condensate drain cap, diagram 14.2. If condensate is backing up to the sensor position, the drain is blocked and it must be cleared before the boiler will work. Inspect external condensate drain pipe and clear away any debris or ice. Release ice blockage by using warm cloths on the pipe.

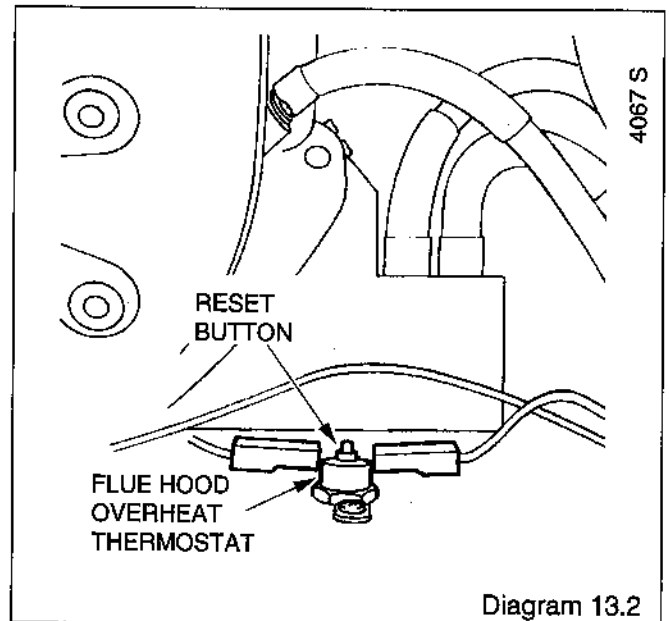
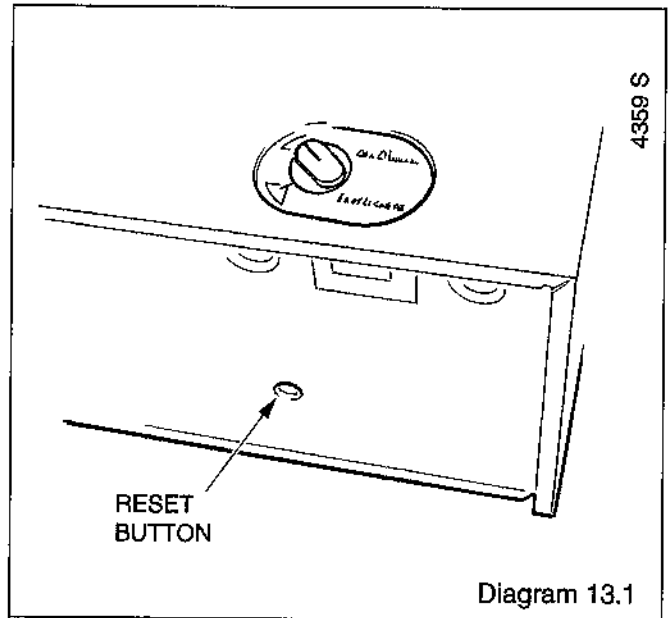

13 Fault Finding

PUMP OVERRUN OPERATION

The control thermostat has a pump overrun facility built into it, and as the control thermostat is set at maximum only, the pump overrun will keep the pump running to allow the boiler to cool down after which it will stop, providing the remote controls are NOT calling for heat.

0505M

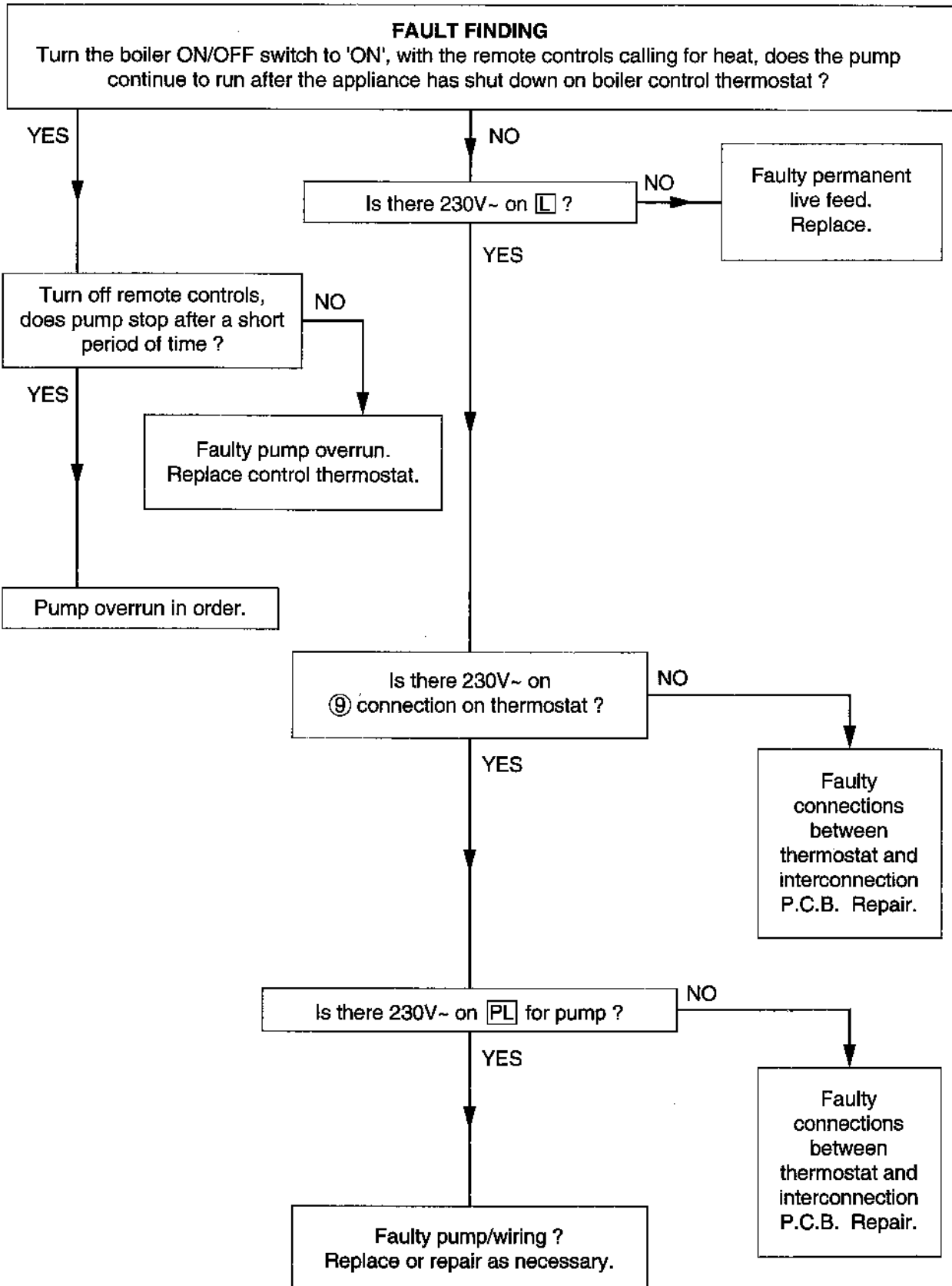

Diagram 13.3

13 Fault Finding

0505M

Before detailed checking of electrical components ensure that remote controls are calling for heat. Check that the gas supply is free of obstructions and purged of air. Check the overheat thermostat and fluehood thermostat have not operated. Isolate the electrical supply and physically check ALL cables, connections and the printed circuit board (P.C.B.) fuse. Check the air tubes to air pressure switch. Make sure ON/OFF switch on boiler is 'ON'.

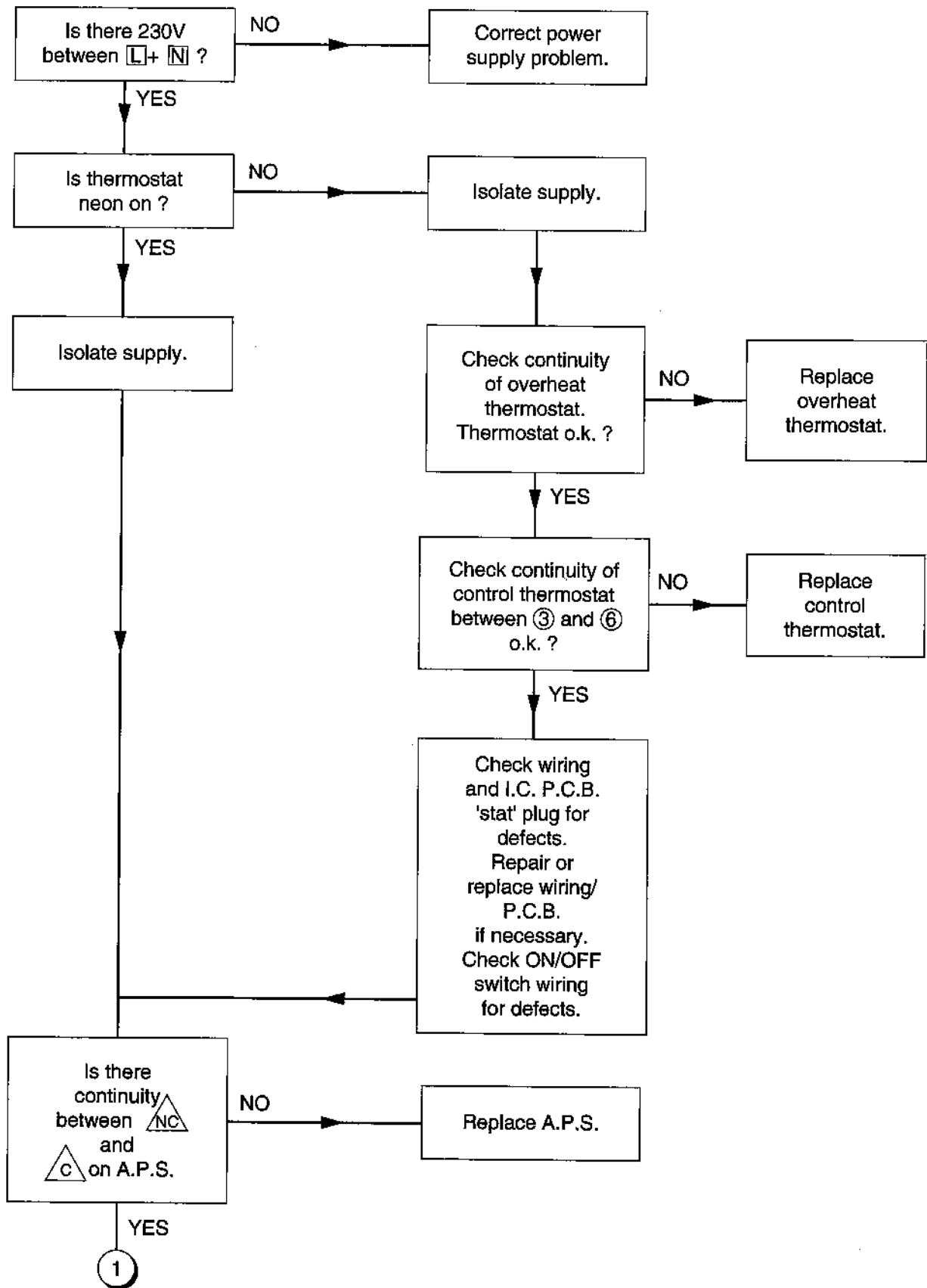

Diagram 13.3

13 Fault Finding

0507M

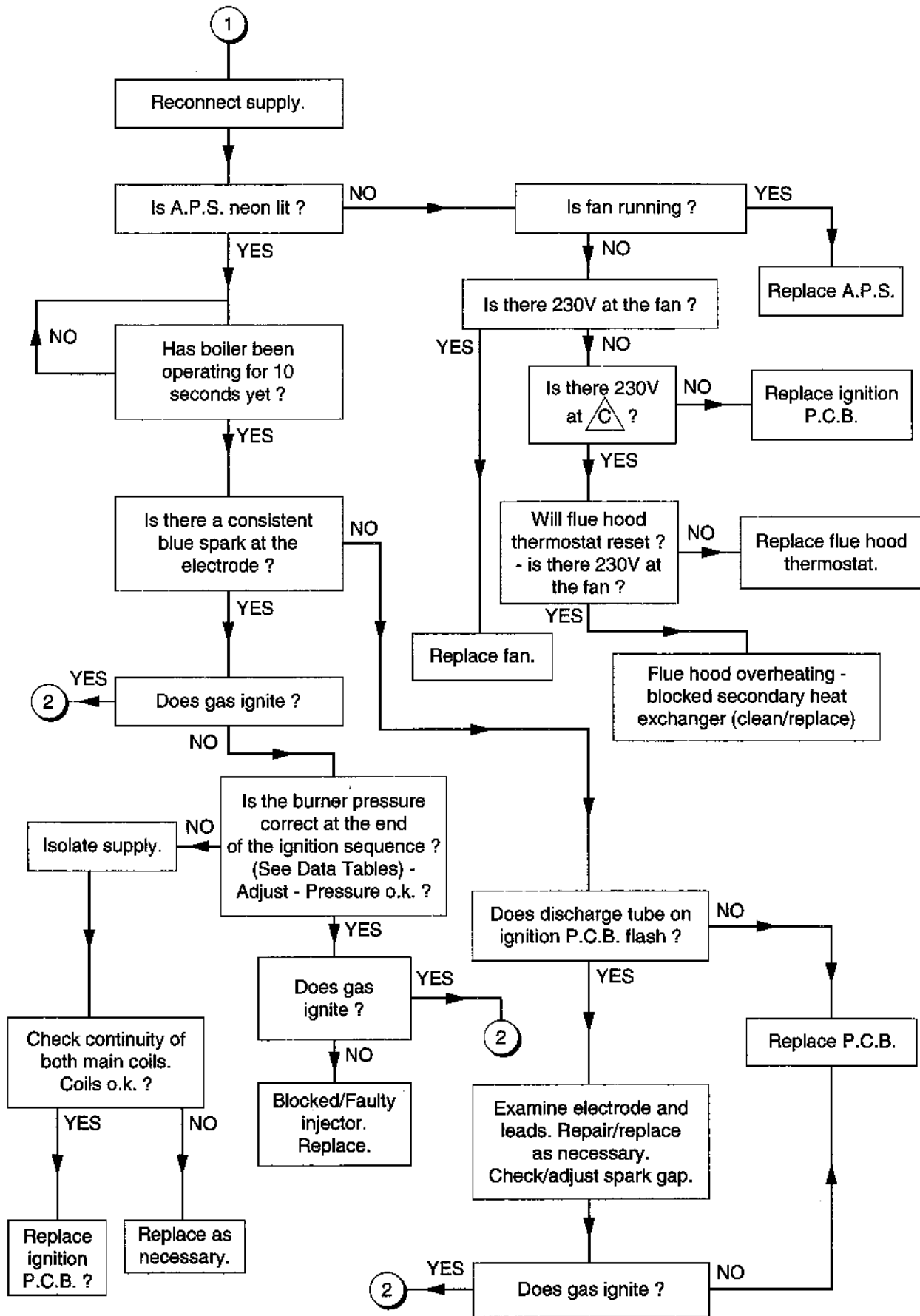

Diagram 13.3

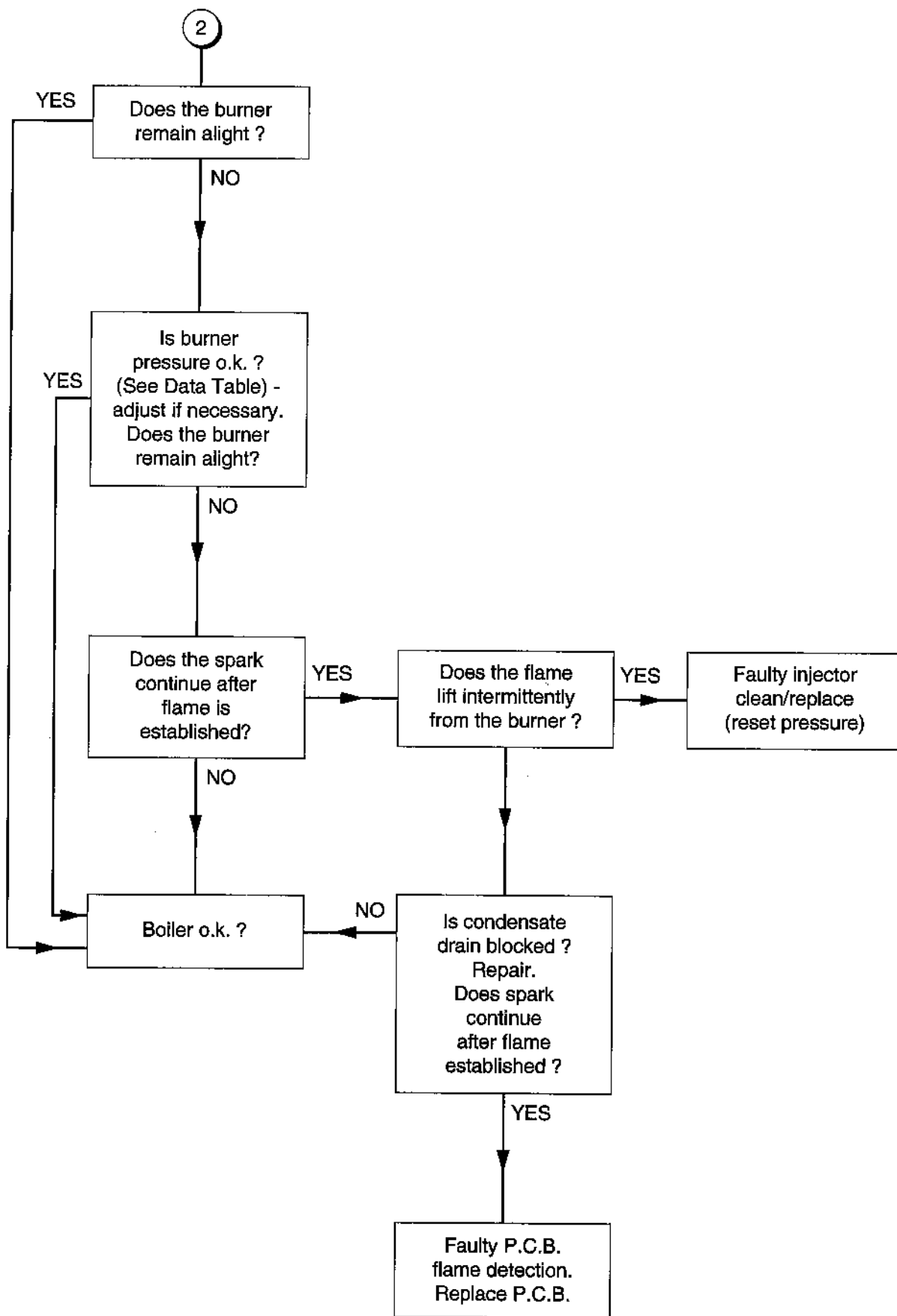
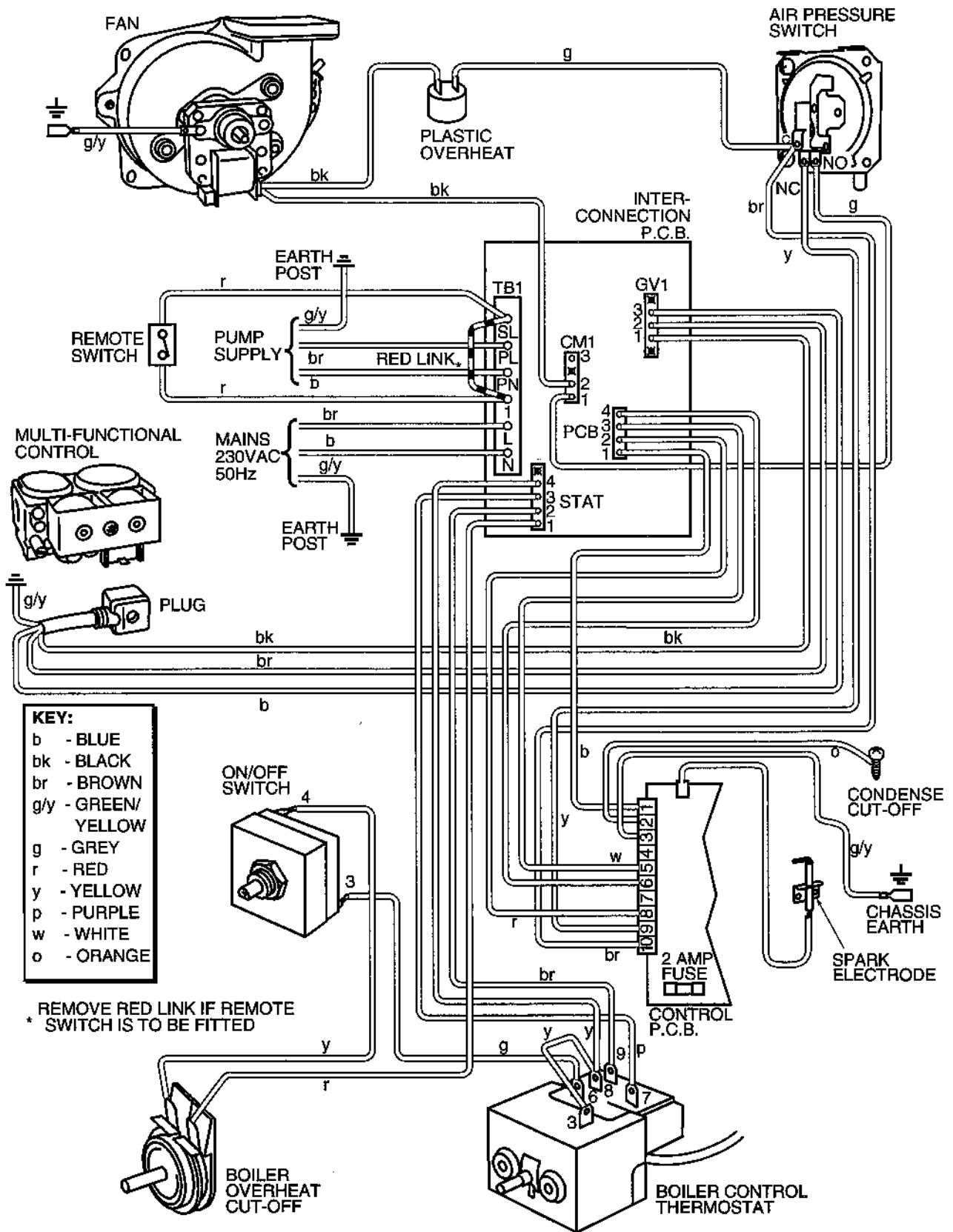
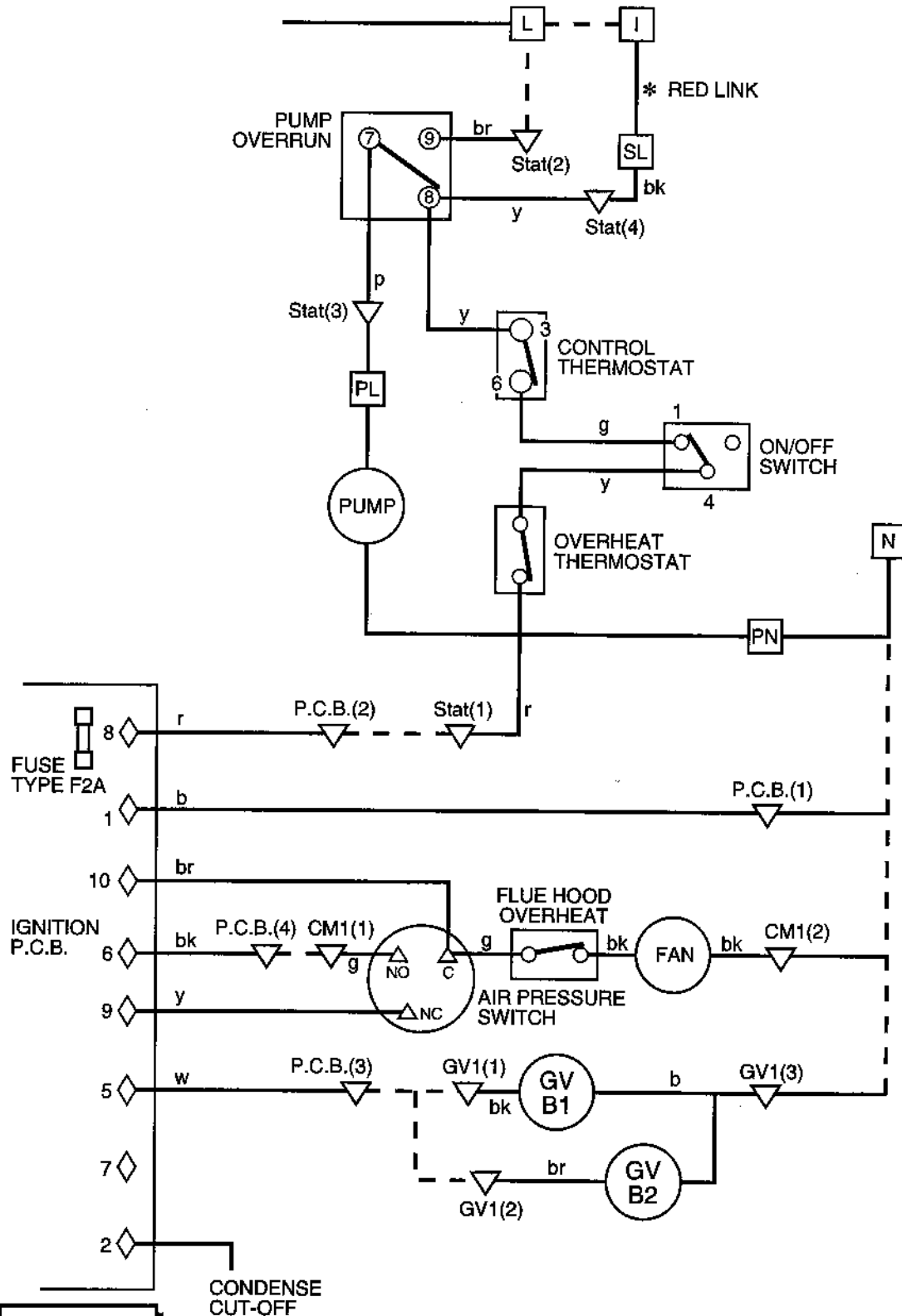

Diagram 13.3



13. Fault Finding

5649



KEY:
 r - RED
 br - BROWN
 p - PURPLE
 b - BLUE
 bk - BLACK
 y - YELLOW
 w - WHITE
 g - GREY

▽ I.C. P.C.B. CONNECTIONS: ie STAT (Pin No. from bottom)
 □ MAIN TERMINAL STRIP CONNECTIONS
 ○ CONTROL THERMOSTAT CONNECTIONS
 ◇ PRINTED CIRCUIT BOARD CONNECTIONS
 * RED LINK MAY HAVE BEEN REMOVED TO FIT REMOTE CONTROLS

Diagram 13.5

14 Replacement of Parts

Notes.

Replacement of parts must be carried out by a competent person.

Before replacing any parts isolate the boiler from the electrical supply and turn the gas supply off at the gas service cock, see diagram 8.1.

Unless stated otherwise, all parts are replaced in the reverse order to removal.

After replacing any parts always test for gas soundness and if necessary carryout functional check of controls.

For the following the front case and inner case cover will need to be removed, see diagram 5.2 and 5.3.

14.1 Spark Electrode

Replace as described in Section 12.4.

14.2 Ignition Lead - diagram 14.2.

Release the control box as Section 9.

To disconnect the ignition lead from the control board, remove the PCB from the mounting pegs, the front two have detachable grips, the rear two are plain supports.

When refitting lead make sure that there is enough length through the gland plate assembly.

14.3 Printed Circuit Boards (PCBs) - diagram 14.3.

Release the control box as Section 9.

Control PCB - diagram 14.3 (top)

Disconnect the electrical plug on the board.

Release from its two support posts and carefully pull the board away noting that the ignition lead is still connected.

It may be necessary to hold some of the wires above the PCB clear, with an electrical screwdriver on removal or refitting.

Release and carefully pull the board away from its supports, noting that the ignition lead is still connected.

Disconnect the ignition lead.

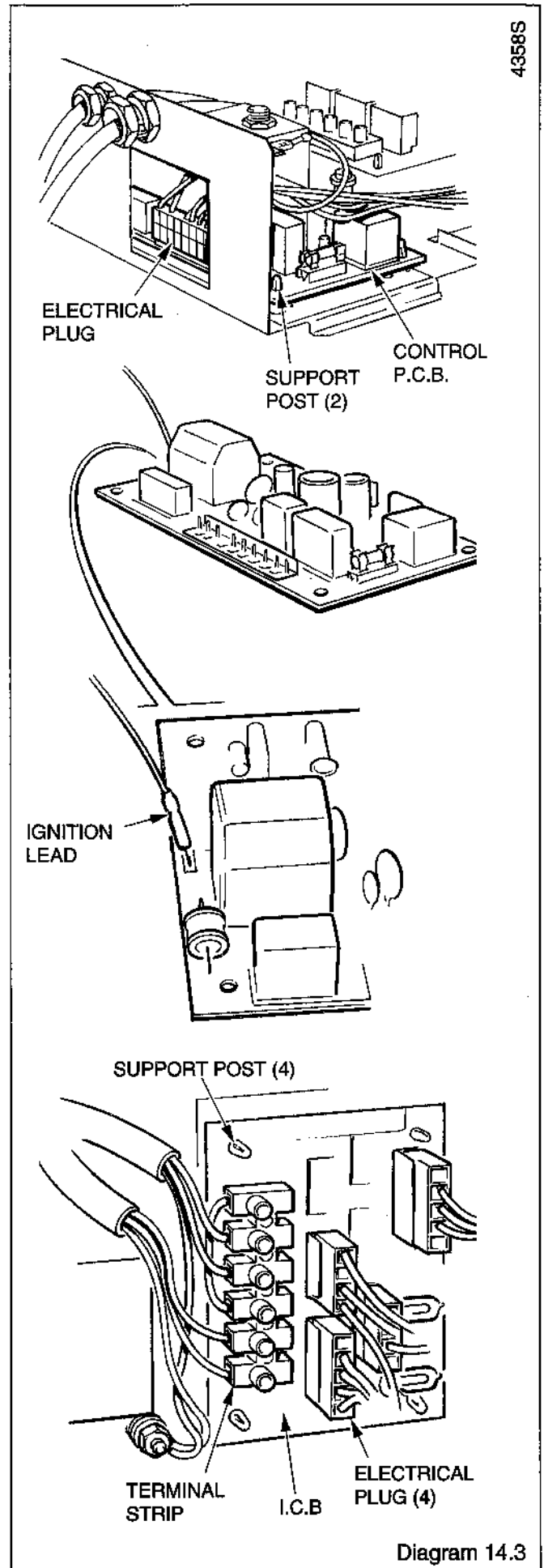
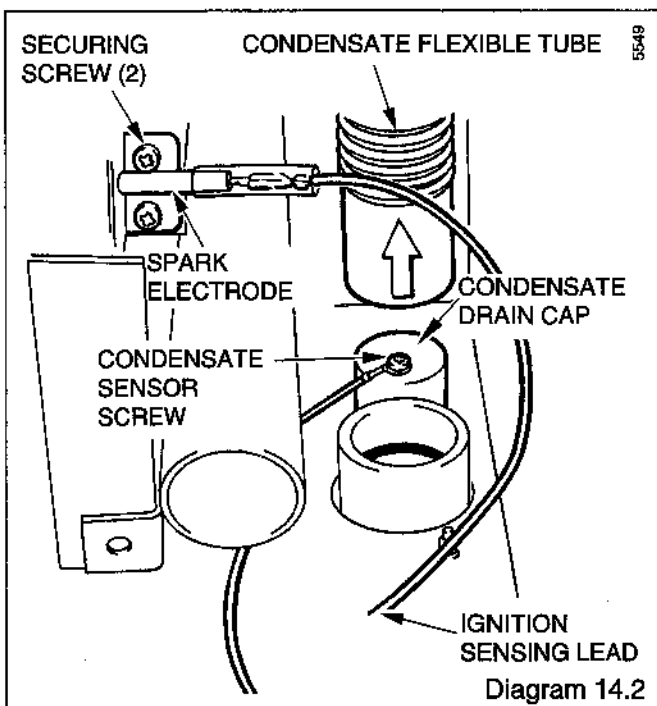

Interconnecting PCB (ICB) - diagram 14.3 (bottom)

Disconnect the electrical plugs and cables from the terminal strip.

Release and carefully pull the board away from its supports.

When refitting refer to wiring diagram 13.2.

14.4 Control Thermostat and Overheat Cutoff

Release the control box, see Section 9.

Control Thermostat - diagram 14.4A and 14.4

Pull off "ON/OFF" switch knob.

Remove the three fascia securing screws and fascia.

Remove the electrical connections from control thermostat body.

Remove the two control thermostat securing screws.

Release the gland plate assembly, see diagram 14.2.

Release and remove the control thermostat phial from the pocket.

Withdraw the capillary through the gland plate and controls grommet.

Slide control thermostat body away from control box.

On replacement smear the phial with the heat sink compound supplied before replacing in the phial pocket.

Make sure that the control thermostat is set to maximum, that is, fully clockwise.

When refitting refer to wiring diagram 13.2.

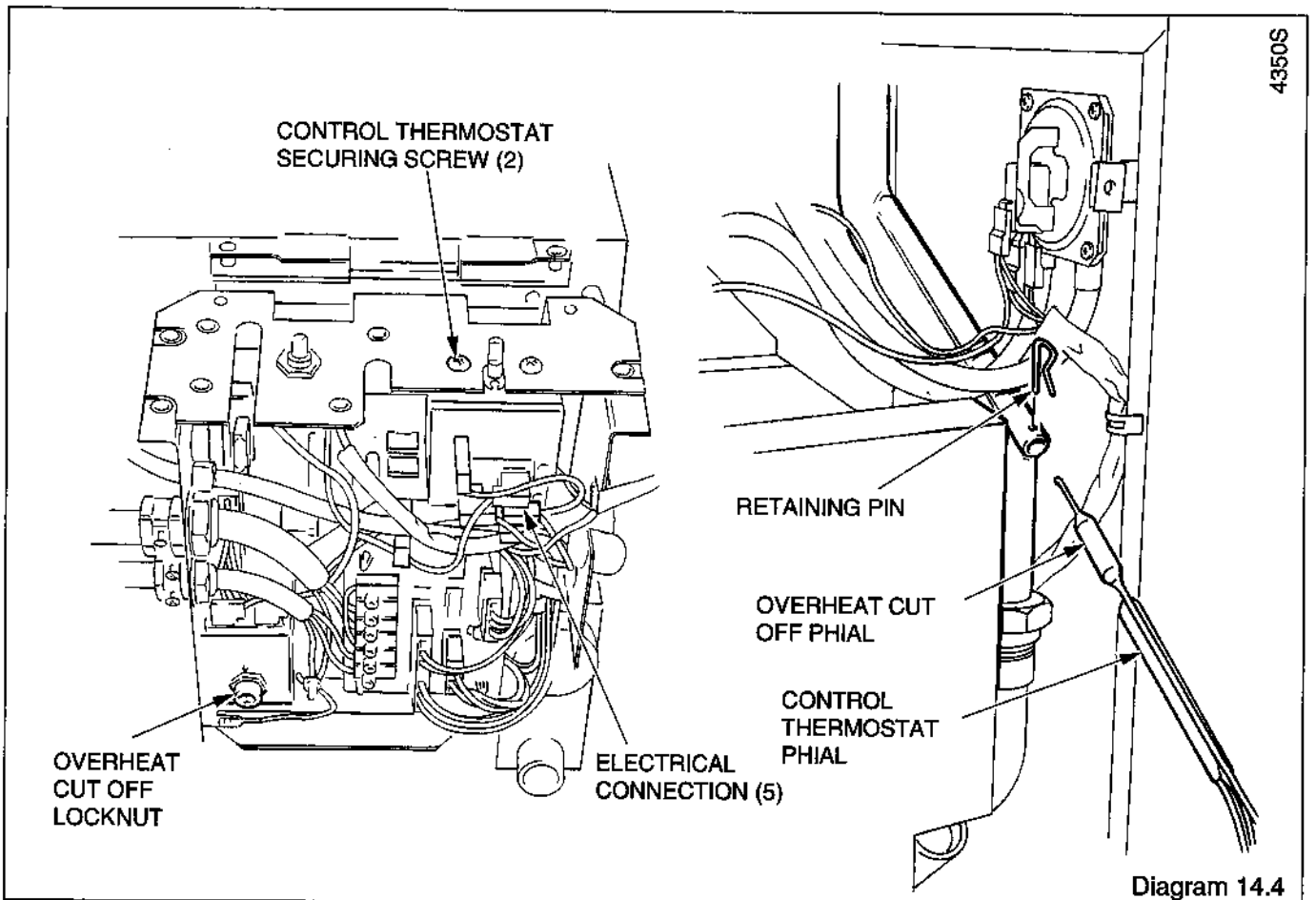
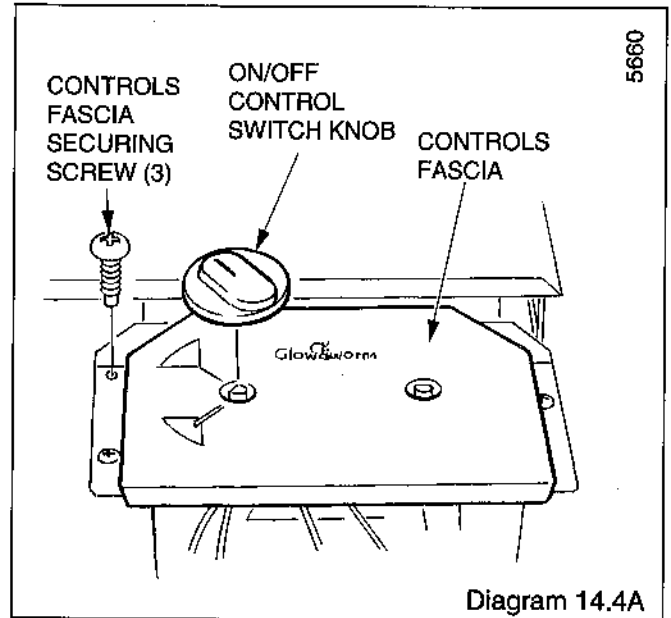

14 Replacement of Parts

Overheat Cutoff - diagram 14.4A and 14.4

Remove the electrical connections.

Remove the locking nut.

Release the gland plate assembly.

Release and remove the overheat cutoff phial from the pocket.

Withdraw the capillary through the gland plate and controls box grommet.

On replacement smear phials with the heat sink compound supplied before replacing in the phial pocket.

When refitting refer to wiring diagram 13.2.

Neatly secure any surplus capillary.

Flue Hood Overheat Cutoff - diagram 14.5.

Remove electrical connections and unfasten screws to release.

Note. The polarity of the connections is not important.

14.5 "ON/OFF" Control - diagram 14.4A and 14.6

Remove the fascia as described in Section 14.4.

Remove the locknut to release the "ON/OFF" control.

Disconnect the purple and yellow leads from both the control and overheat thermostats.

When refitting refer to wiring diagram 13.2

14.6 Air Pressure Switch - diagram 14.7

Remove the air pressure tubes and electrical connections.

Remove the two securing screws to release the air pressure switch.

When fitting the replacement make sure that all the air pressure tubes and electrical connections are made as shown.

14.7 Multifunctional Control - diagram 8.1

Disconnect the screws and electrical plugs at the multifunctional control.

Support the multifunctional control and remove the four screws from the flanged connection, undo the union at the gas service cock and remove the support bracket securing screw.

Remove the multifunctional control by easing the flange and service cock apart.

Remove the union half and refit to the replacement multifunctional control.

Use a little jointing compound on the external thread only, to make sure of gas soundness.

Make sure that the "O" ring is in place in the flanged connection is replaced.

It will be necessary to purge the pipework and multifunctional control before relighting and checking pressure, refer to "Commissioning".

14.8 Solenoid - diagram 8.1.

Remove the solenoid securing screw and pull the solenoids and carrier forward to release.

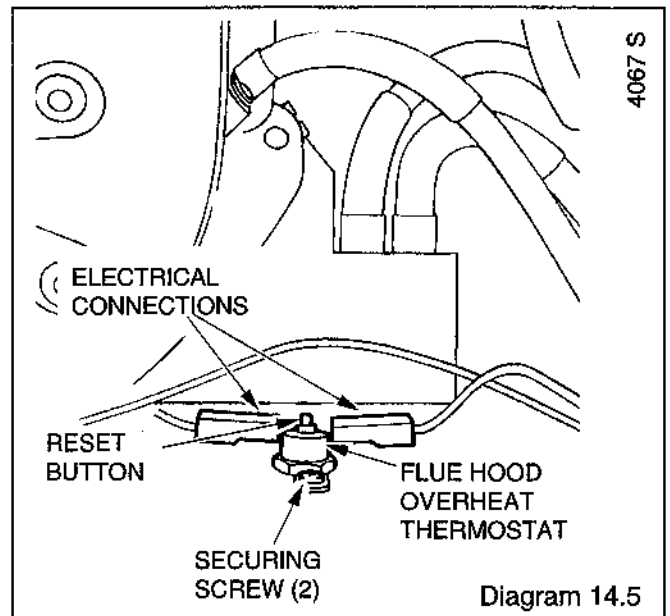

Diagram 14.5

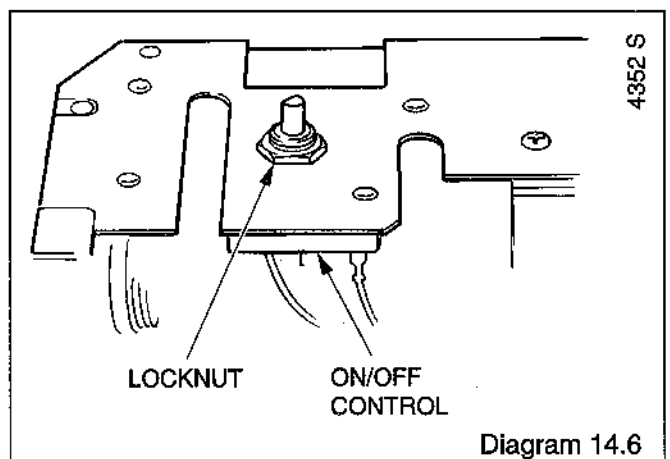

Diagram 14.6

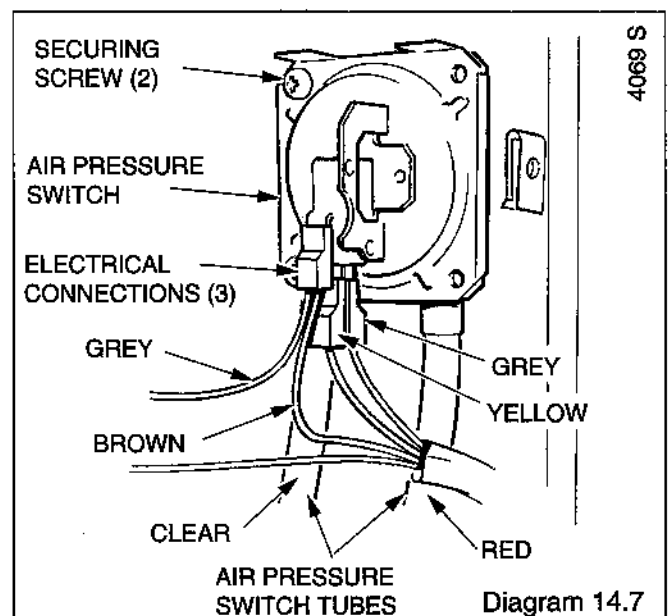

Diagram 14.7

14 Replacement of Parts

14.9 Fan

Refer to Section 12.1 "Heat Exchanger Cleaning".

Make sure that the earth connection is remade onto the replacement fan.

The polarity of the electrical connections is not important.

14.10 Injector

Refer to Servicing, Section 12.3.

Fit new injector as shown.

Note. The replacement injector is supplied complete with the gas supply pipe manifold.

14.11 Heat Exchanger - diagram 14.8

Note. To carryout the following operations it will be found more convenient if the whole of the heat exchanger and burner are removed as a unit.

Follow the relevant parts of Servicing Section and remove the bypass heat shield, fan/flue hood, combustion chamber front panel, heat exchanger baffle, spark electrode, injector and thermostat phial.

Release the flexible tube from the condense drain trap, this is a push-fit.

Release union connections and the six securing screws, then remove the complete assembly.

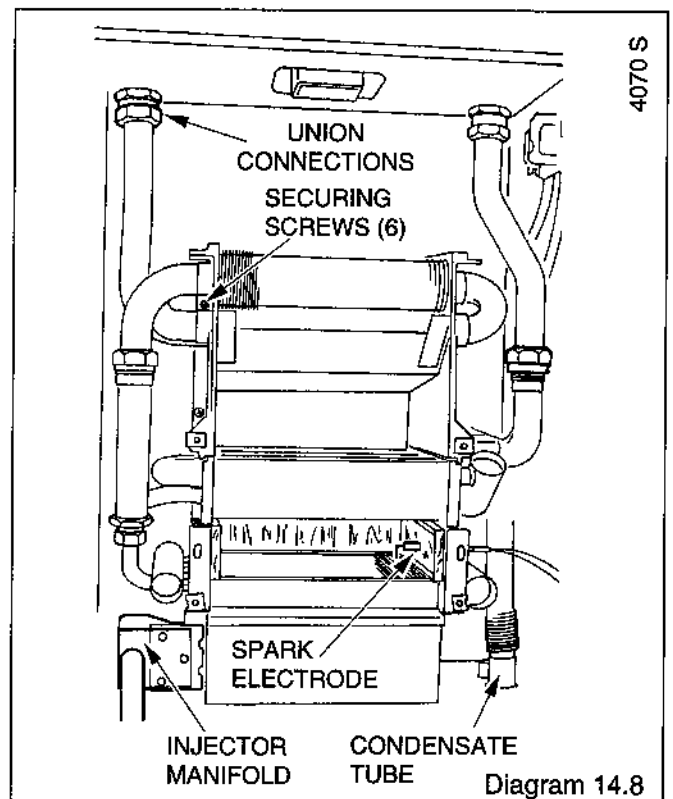

Heat Exchanger - Secondary - diagram 14.9

Disconnect the union connector.

Remove and fit flexible hose to replacement.

Heat Exchanger - Primary - diagram 14.10

Disconnect the three union connections.

14.12 Burner - diagram 14.9

Note. To carryout the following operation it will be found more convenient if the whole of the heat exchanger and burner are removed as a unit.

Follow the relevant parts of Servicing Section and remove the bypass heat shield, fan/flue hood, combustion chamber front panel, heat exchanger baffle, spark electrode, injector and thermostat phial.

Release the flexible tube from the condense drain tap, this is a push-fit.

Release union connections and the six securing screws, then remove the complete assembly.

Remove the insulation as Section 14.14 and keep for use in the replacement.

Disconnect the two union connections.

Fit the insulation.

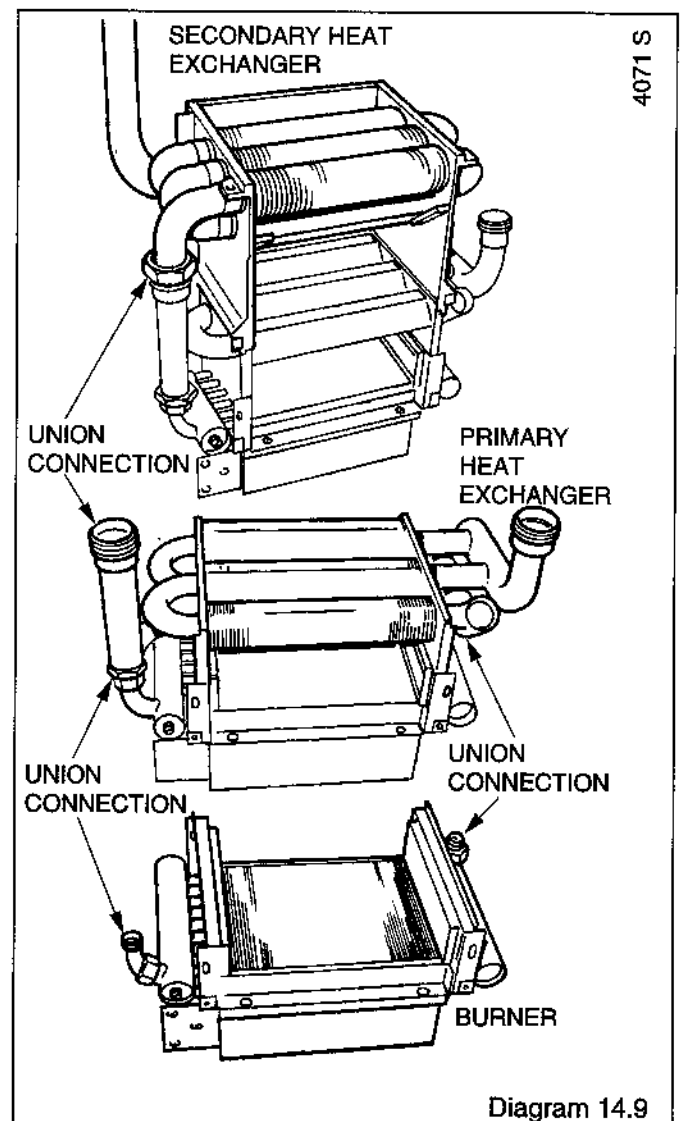

14 Replacement of Parts

14.13 Insulation - Rear - diagram 14.10

With the heat exchanger and burner assembly removed, as Sections 14.10 and 14.11, the rear insulation pad can be removed as shown.

14.14 Insulation - Combustion Chamber Front Panel - diagram 14.11

Remove the two screws from the viewing window then slide the insulation pad off.

14.15 Insulation - Sides - diagram 14.12

Remove the spark electrode, refer to Section 12.4.

Remove the insulation by sliding it out.

14.16 Condensate Sensor - diagram 14.13

Refer to the relevant parts of Section 14.2 to remove the screw.

The sensing screw is fitted to a push fit cap which can be levered off for easy access.

Note. The condensate flexible tube is a push fit and can be removed from the condensate drain trap to improve access to the screw.

When replacing the cap make sure that it is firmly in place and that the ring tag is pointing away from the casing side.

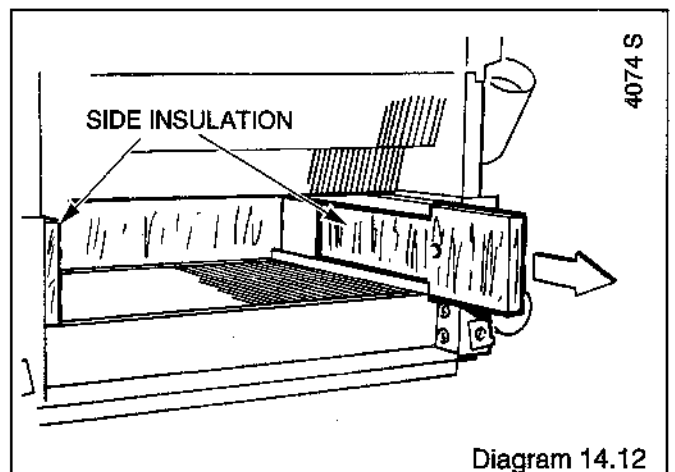
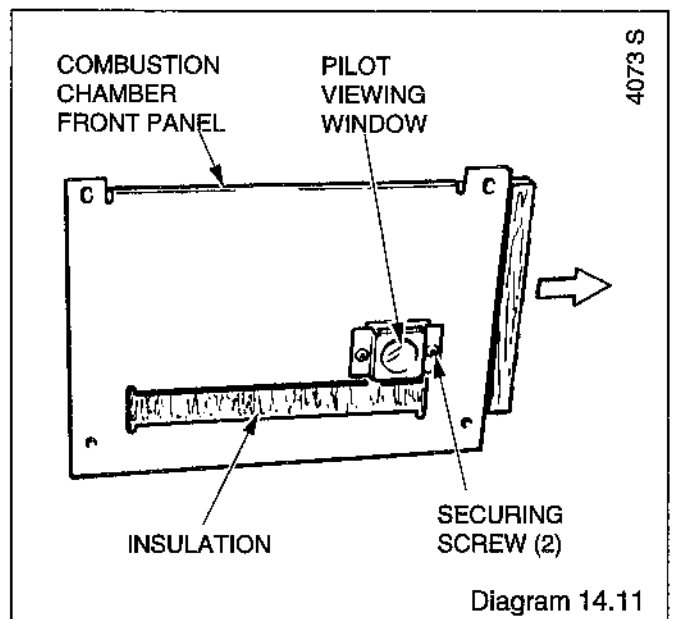
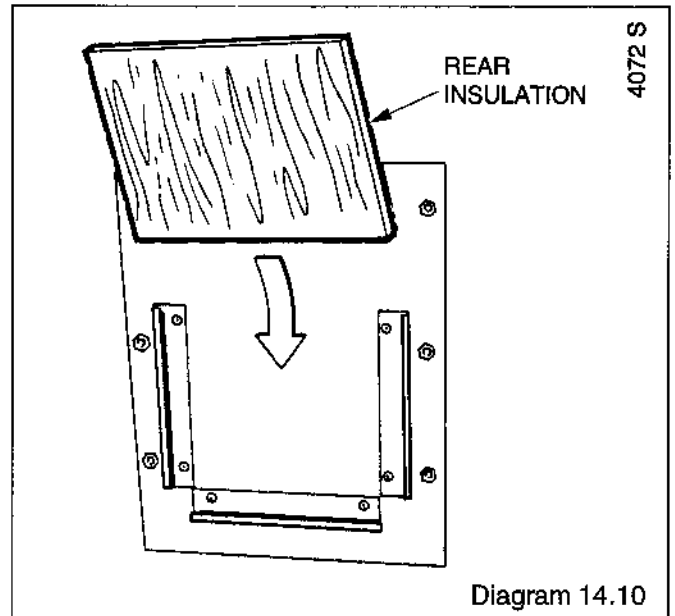

14 Replacement of Parts

14.17 Viewing Window Glass - diagram 14.14

Remove the two screws to release the frame and glass.

When replacing take care not to damage the gasket.

14.18 Inner Case Cover Seal

When removing seal make sure that all the old adhesive is removed.

When fitting new seal make sure that it fits correctly and has not buckled.

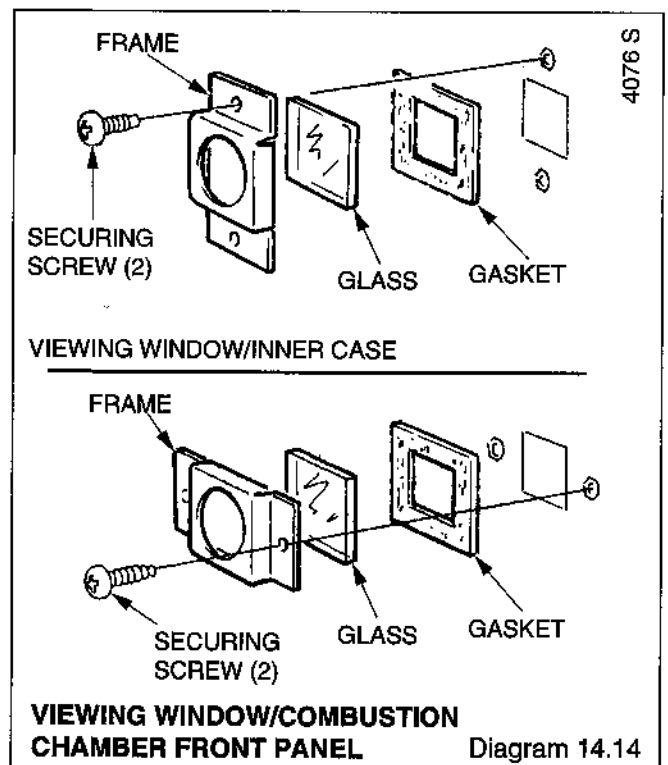
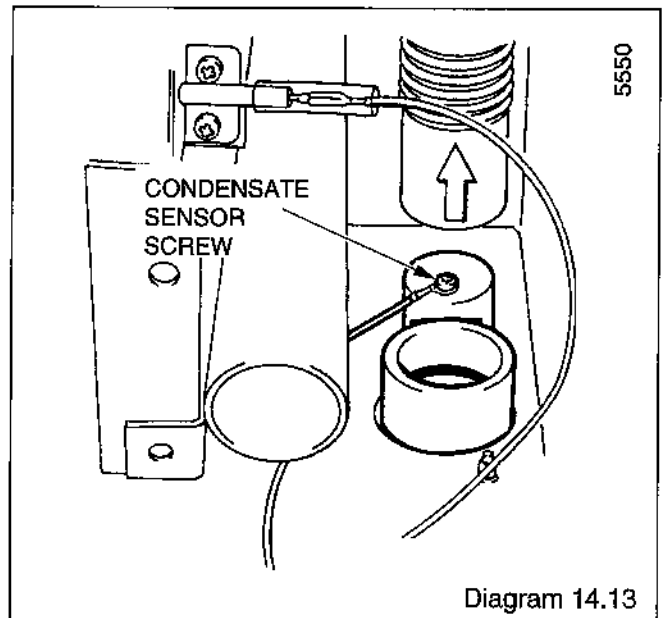

15 Spare Parts

When ordering spare parts, please quote the appliance name and serial number, to be found on the data label, visible when the outer casing is removed.

If order from the local gas undertaking also quote the GC number of the part.

Key No	Part No	Description	GC Part No
1	800831	Multifunctional control	
2	800375	Solenoid	278 128
3	800476	Thermostat - control	278 094
4	800477	Thermostat - overheat cutoff	278 095
4a	800466	Overheat Thermostat	278 047
5	450260	On/off control	278 276
6	800467	On/off switch knob	278 049
7	202135	Air pressure switch	313 303
8	203154P	Gas manifold assembly NG - 50e	278 087
8	203149P	Gas manifold assembly NG - 60e	278 099
9	202015	Fuse	334 750
10	208302	Sight glass	312 419
	208093	Gasket - sight glass - not shown	312 420
11	WW4617	Ignition lead	
12	202211	Control board (PCB)	379 239
13	-	-	-
14	800468	Fan	278 050
15	202625	Electrode	278 096
16	202237	Interconnection board	-

15 Spare Parts

6297

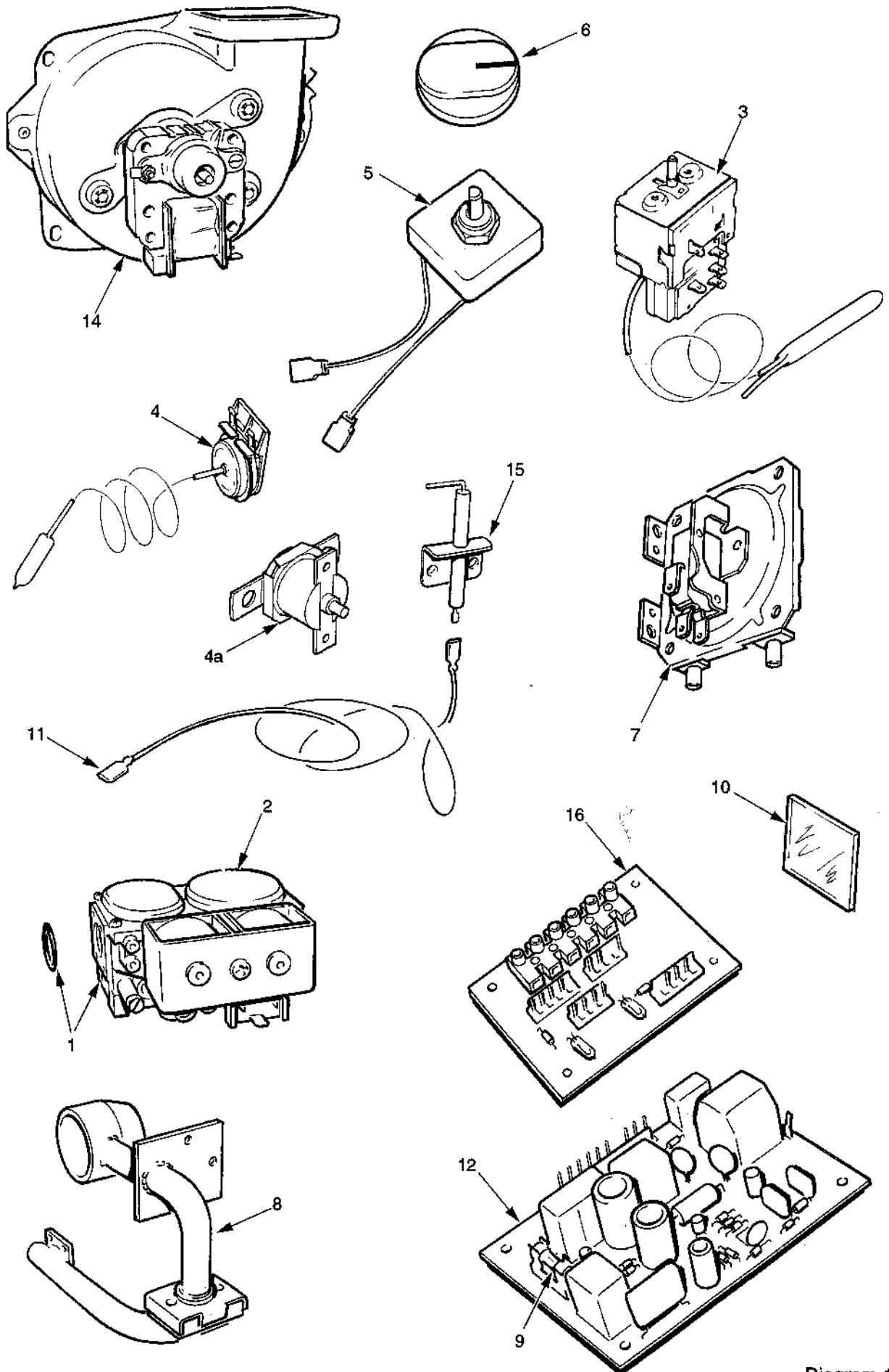

Diagram 15.1

Because of our constant endeavour for improvement details may vary slightly from those in the instructions.