

Betacom

Installation and Servicing

24c

G.C. No. 47-019-08

30c

G.C. No. 47-019-09

**High Efficiency
Condensing Combination
Boilers**

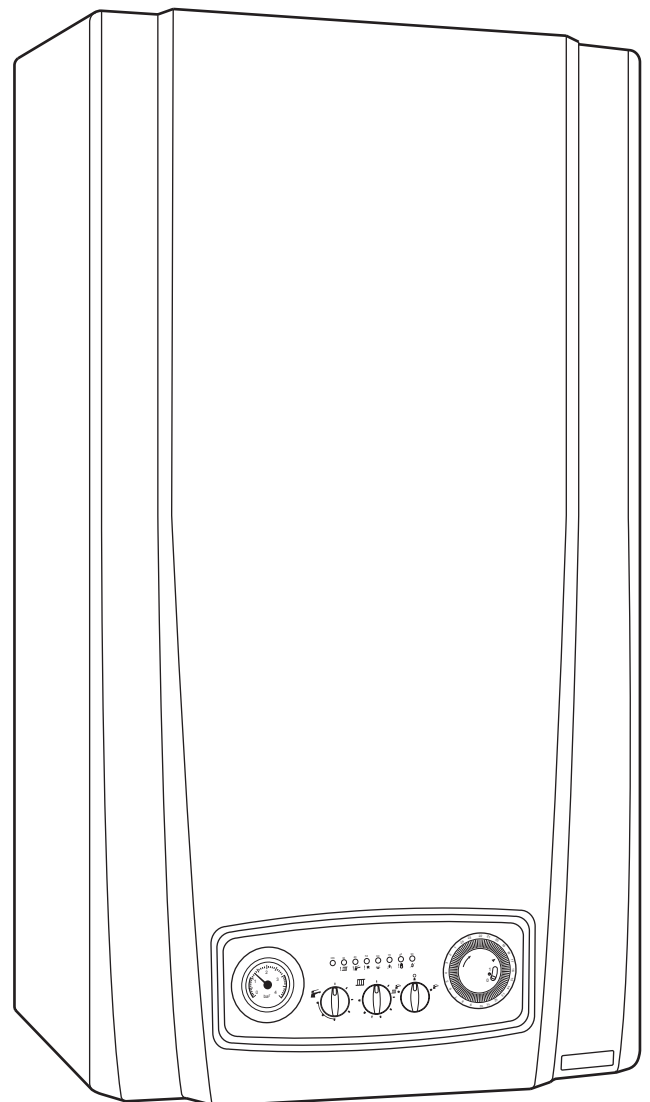

Guarantee Registration

Thank you for installing a new Glow-worm appliance in your home.

Glow-worm appliances are manufactured to the very highest standard so we are pleased to offer our customers a Comprehensive First Year Guarantee. We recommend you complete and return as soon as possible your guarantee registration card.

If your guarantee registration card is missing you can obtain a copy or record your registration by telephoning the Glow-worm Customer Service number 01773 828100.

Customer Service:

01773 828100

Technical Helpline:

01773 828300

General and Sales enquiries:

Tel. 01773 824639

Fax: 01773 820569

To register your Glow-worm appliance call:

0800 0732142

Benchmark places responsibilities on both manufacturers and installers. The purpose is to ensure that customers are provided with the correct equipment for their needs, that it is installed, commissioned and serviced in accordance with the manufacturer's instructions by a competent person approved at the time by the Health and Safety Executive and that it meets the requirements of the appropriate Building Regulations. The Benchmark Checklist can be used to demonstrate compliance with Building Regulations and should be provided to the customer for future reference.

Installers are required to carry out installation, commissioning and servicing work in accordance with the Benchmark Code of Practice which is available from the Heating and Hotwater Industry Council who manage and promote the Scheme.

Visit www.centralheating.co.uk for more information.



These instructions consist of, Installation, Servicing, Fault Finding, Replacement of Parts and Spares. The instructions are an integral part of the appliance and must, to comply with the current issue of the Gas Safety (Installation and Use) Regulations, be handed to the user on completion of the installation.

CONTENTS	DESCRIPTION	SECTION	PAGE
INTRODUCTION	Warnings		4
	Important Information		4
	Statutory Requirements		5
	Boiler Design		6
	Safety Devices		6
	Servicing, Maintenance and Spare Parts		7
	Boiler Specification		8
	Boiler Components		9
INSTALLATION	Boiler Dimensions and Hydraulic Schematic	2	10
	Boiler Location, Clearances and Ventilation	3	11
	Flue Options and Terminal Clearances	4	12
	Water System - Heating	5	14
	Water System - Domestic Hot Water	5	15
	Installation Preparation	6	16
	Boiler Fixing / Gas / Water / Safety Discharge Connection	7	18
	System Pipes and Condensate Connection	8	19
	Condensate Connections	8	20
	Telescopic Flue - Length, Preparation and Installation	9	21
	Standard Flue - Length, Preparation and Installation	9	25
	Vertical Flue - Length, Preparation and Installation	9	29
	Twin Flue - Length, Preparation and Installation	9	32
	Plume Management Kit	9	35
	Electrical Connection	10	35
Commissioning	11	38	
MAINTENANCE	Servicing	12	46
	Fault Finding	13	50
	Replacement of Parts	14	56
	Spare Parts	15	64
	Manual Handling	16	66
	Declaration of Conformity	17	67

WARNINGS

Gas Leak or Fault

Turn off the gas emergency control valve immediately. Eliminate all sources of ignition, i.e. smoking, blowlamps, hot air guns etc. Do not operate electrical lights or switches either on or off. Open all doors and windows, ventilate the area.

Metal Parts

This boiler contains metal parts (components) and care should be taken when handling and cleaning, with particular regard to edges.

Sealed Components

Under no circumstances must the user interfere with or adjust sealed parts.

Important Information

Gas Category

This boiler is for use only on G20 natural gas.

Control of Substances Hazardous to Health

Under Section 6 of The Health and Safety at Work Act 1974, we are required to provide information on substances hazardous to health.

The adhesives and sealants used in this appliance are cured and give no known hazard in this state.

CAUTION:

While there are no substances harmful to health contained within this boiler, some component parts of the boiler (insulation pads, gaskets and rope seals) are manufactured from man made fibres. When damaged or broken these fibres may cause a temporary irritation. High dust levels may irritate eyes and upper respiratory system. It is important therefore, that sensible precautions are applied when exchanging components.

If you have a history of skin complaint you may be susceptible to irritation.

Normal handling should not cause discomfort, but follow good hygiene and wash your hands before eating, drinking or going to the lavatory.

If you suffer irritation to the eyes or severe irritation to the skin seek medical advice.

Manual Handling

With regards to the "Manual Handling Operations, 1992 Regulations", the appliance exceeds the recommended weight for a one man lift, refer to section 16 for more information.

The handling of the boiler may involve lifting, pushing and pulling, the use of a sack truck may be required.

The following handling techniques and precautions should be considered:

- Grip the boiler at its base
- Be physically capable
- Use safety clothing where appropriate, e.g. gloves, safety footwear.

Ensure safe lifting techniques are used

- Keep back straight.
- Avoid twisting at the waist.
- Avoid upper body/top heavy bending.
- Always grip using the palm of the hand.
- Use designated hand holds.
- Keep load as close to body as possible.
- Always use assistance if required.

Electrical Supply

The boiler MUST be earthed.

All system components shall be of an approved type and all wiring to current I.E.E. wiring regulations.

External wiring must be correctly earthed, polarised and in accordance with the relevant standards.

In GB, this is BS 7671.

In IE, this is the current edition of ETCI rules.

The boiler MUST be connected to a permanent 230V ac, 50Hz supply.

Connection of the whole electrical system of the boiler, including any heating controls, to the electrical supply MUST be through one common isolator and must be fused 3 Amp maximum.

Isolation should be by a double pole switched fused spur box, with a minimum gap of 3mm for both poles. The fused spur box should be readily accessible and preferably adjacent to the appliance. It should be identified as to its use.

Alternatively connection can be made through an unswitched shuttered socket and 3A fused 3-pin plug both to the current issue of BS 1363, provided they are not used in a room containing a bath or shower.

Wiring to the boiler must be PVC 85°C insulated cable, not less than 0.75mm² (24/0.20mm).

Testing and Certification

This boiler is tested and certificated for safety and performance. It is, therefore, important that no alteration is made to the boiler, without permission, in writing, by Glow-worm.

Any alteration not approved by Glow-worm, could invalidate the certification, boiler warranty and may also infringe the current issue of the statutory requirements.

Statutory Requirements

CE Mark

This boiler meets the requirements of Statutory Instrument, No. 3083 The Boiler (Efficiency) Regulations, and therefore is deemed to meet the requirements of Directive 92/42/EEC on the efficiency requirements for new hot water boilers fired with liquid or gaseous fuels.

Type test for purposes of Regulation 5 certified by:

Notified body IMQ 51BP2727 CE Directives 90/396/EEC.
51BP2728DR CE Directives 92/42/EEC.

Product/production certified by:

Notified body IMQ 51BP2727 CE Directives 90/396/EEC.
51BP2728DR CE Directives 92/42/EEC.

The CE mark on this appliance shows compliance with:

1. Directive 90/396/EEC on the approximation of the laws of the Member States relating to appliances burning gaseous fuels.
2. Directive 73/23/EEC on the harmonisation of the Laws of the Member States relating to electrical equipment designed for use within certain voltage limits.
3. Directive 89/336/EEC on the approximation of the Laws of the Member States relating to electromagnetic compatibility.

IMPORTANT

Where no British Standards exists, materials and equipment should be fit for their purpose and of suitable quality and workmanship.

The installation of this boiler must be carried out by a **competent person** approved at the time by the Health and Safety Executive and in accordance with the rules in force in the countries of destination.

Manufacturer's instructions must not be taken as overriding statutory requirements.

Statutory Requirements

In GB, the installation of the boiler must comply with the requirements of the current issue of BS6798 and be carried out by a **competent person** approved at the time by the Health and Safety Executive and as described in the following regulations:

The manufacturer's instructions supplied.

The Gas Safety (Installation and Use) Regulations.

The appropriate Buildings Regulations either The Building Regulations, The Building Regulations (Scotland), The Building Regulations (Northern Ireland).

The Water Fittings Regulations or Water byelaws in Scotland.

The Health and Safety at Work Act, Control of Substances Hazardous to Health (COSHH).

The Current I.E.E. Wiring Regulations.

Where no specific instructions are given, reference should be made to the relevant British Standard Code of Practice.

In IE, the installation must be carried out by a **competent person** approved at the time by the Health and Safety Executive and installed in accordance with the current edition of I.S.813 "Domestic Gas Installations", the current Building Regulations and reference should be made to the current ETCI rules for Electrical Installation.

GB: the following Codes of Practice apply:

BS4814, BS6798, BS5440 Part 1 and 2, BS5546 Part 1, BS5449, BS6891, BS6700, BS7074 Part 1 and 2, BS7593, BS7671.

IE: I.S.813, BS5546, BS 5449, BS 7074, BS 7593.

NOTE: For further information, see the current issue of the Building Regulations, approved document L1 (in the UK) and the following current issues of:

1) Central heating system specification (CheSS) and

2) Controls for domestic central heating system and hot water. BRECSU.

Gas Supply

The gas installation must be in accordance with the relevant standards.

In GB, this is BS6891.

In IE, this is the current edition of I.S.813 "Domestic Gas Installations".

The internal diameter of the gas supply from the governed meter to the boiler's gas inlet connection must not be less than 22mm.

The supply from the governed meter must be of adequate size to provide a steady inlet working pressure of 20mbar (8in wg) (for natural gas) at the boiler. In addition to the demand of any other gas appliances being serviced from that supply.

On completion, test the gas installation for tightness using the pressure drop method and suitable leak detection fluid, purge in accordance with the above standard.

Domestic Hot Water

All domestic hot water circuits, connections, fittings must be in accordance with the relevant standards and water supply regulations.

GB: Guidance G17 to G24 and recommendation R17 to R24 of the Water Regulations Guide.

IE: The current edition of I.S.813 "Domestic Gas Installations".

Heating System

In GB, it is necessary to comply with the Water Supply (Water Fittings) Regulations 1999 (for Scotland, the Water Byelaws 2000, Scotland).

To comply with the Water regulations your attention is drawn to: The Water Regulations guide published by the Water Regulations Advisory Service (WRAS) gives full details of the requirements.

In IE, the requirements given in the current edition of I.S.813 "Domestic Gas Installations" and the current Building Regulations must be followed.

Boiler Design

Boiler Design

These boilers are designed for use as part of a sealed water central heating system with fully pumped circulation. The pump, expansion vessel and associated safety devices are all fitted within the boiler.

The appliance has a built in frost protection device that protects the boiler from freezing.

Once the controls are set the boiler operates automatically.

Condensate Drain

A plastic drain pipe must be fitted to allow discharge of condensate to a drain. Condensate should, if possible, be discharged into the internal household draining system. If this is not practical, discharge can be made externally into the household drainage system or a purpose designed soak away, see section 9 for more details.

Plumbing from flue terminal

Like all condensing boilers this appliance will produce a plume of condensation from the flue terminal in cool weather. This is due to the high efficiency and hence low flue gas temperature of the boiler.

This is normal and not an indication of a fault.

Safety Devices

Electrical Supply Failure

The boiler will not work without an electrical supply.

Normal operation of the boiler should resume when the electrical supply is restored.

Reset any external controls, to resume normal operation of the central heating.

If the boiler does not resume normal operation reset the appliance. If the boiler does not resume normal operation after this call your Installation/Service company or Glow-worm service.

Overheating Safety

The boiler software is designed to recognise the potential for an overheat (Boiler Lockout). The temperature of the water flowing from the primary heat exchanger is monitored by an overheat thermostat located on the outlet pipe. If the water temperature gets too hot the switch opens, cutting off the electrical supply to the gas valve and causing the boiler to 'Lockout'. Once activated the boiler has to be manually re-set by switching the control knob off (for 15 seconds) and on again.

Low Water Pressure

A hydraulically operated primary pressure sensor monitors water pressure or water shortage in the primary hydraulic circuit and will switch the boiler off if the pressure is below 0.3bar. The boiler will not operate until the circuit has been re-pressurised.

Flue Blockage

For HK type; an air pressure switch situated in the boiler's fan compartment monitors the boiler's flue operation. If a partial obstruction within the flue occurs the fan will continue operating but the boiler's burner will shut down until the blockage is cleared.

Frost protection

The boiler's control unit has in-built frost protection device that fires the boiler's burner when the temperature of primary hydraulic water falls below 6°C. The device works irrespective of any room thermostat setting and will protect the complete heating system. On reaching a water temperature of 15°C the boiler reverts to normal operation.

NOTE: If the boiler will not be used for long periods of time during cold weather, in order to avoid freezing the electric supply must be left ON and all the central heating isolation valves must be left open. The internal frost protection device will then operate the boiler if the temperature falls too low. However, if the electrical supply is to be turned off the boiler, the heating system and domestic hot water circuit must be drained.

Safety Discharge Valve

A safety discharge valve and discharge pipe are fitted to the boiler. This valve must not be touched. Should there be any discharge from the pipe, isolate the boiler electrical supply and call your installer or Glow-worm's own service organisation using the telephone number on the inside front cover of this booklet.

Condensate Drain Blockage

As a safety feature the boiler will stop working if the condensate drain becomes blocked. During freezing conditions this may be due to the forming of ice in the condensate drain external to the house. Release an ice blockage by the use of warm cloths on the pipe, the boiler should then restart.

NOTE: If the boiler fails to resume normal operation and all external controls are calling for heat, then call your Installation/Service company or Glow-worm service.

Servicing, Maintenance and Spare Parts

Servicing and Maintenance

To ensure the continued efficient and safe operation of the boiler it is recommended that it is checked and serviced as necessary at regular intervals. The frequency of servicing will depend upon the particular installation conditions and usage, but in all cases the boiler must be serviced at least once a year.

If this appliance is installed in a rented property there is a duty of care imposed on the owner of the property by the current issue of the Gas Safety (Installation and Use) Regulations, Section 35.

Servicing/maintenance should be carried out by a **competent person** in accordance with the rules in force in the countries of destination.

To obtain service, please call your installer or Glow-worm's own service organisation using the telephone number on the inside front cover of this literature.

"Benchmark" scheme

Glow-worm support the Benchmark initiative. It is very important that the Installation, Commissioning and Service Record is completed by the installation engineer and handed over to the user.

Spare Parts

Remember, when replacing a part on this appliance, use only spare parts that you can be assured conform to the safety and performance specification that we require. Do not use reconditioned or copy parts that have not been clearly authorised by Glow-worm.

If a part is required contact Glow-worm's own service organisation.

Please quote the name of the appliance, this information will be on the name badge on the front of the appliance.

If in doubt seek advice from the local gas company or Glow-worm's own service organisation using the telephone number on the inside front cover of this booklet.

Boiler Specification

Boiler Design

These boilers are designed for use as part of a sealed water central heating system with fully pumped circulation. The pump, expansion vessel and associated safety devices are all fitted within the boiler.

The appliance has a built in frost protection device that protects the boiler from freezing. Once the controls are set the boiler operates automatically.

BOILER SPECIFICATION	24c	30c
Lift weight	37 kg (82 lb)	38 kg (84 lb)
Total weight (installed)	40 kg (88 lb)	41 kg (90 lb)
Gas connection Ø O.D.	22mm. copper	22mm. copper
Heating flow and return connection Ø O.D.	22mm. copper	22mm. copper
Domestic hot water connection Ø O.D.	15mm. copper	15mm. copper
Condensate connection Ø I.D.	21.5mm. plastic	21.5mm. plastic
Safety valve discharge connection Ø O.D.	15mm. copper	15mm. copper
Heating circuit safety valve (preset)	3.5 bar (53.5 lbf/in ²)	3.5 bar (53.5 lbf/in ²)
Heating system minimum pressure	0.8 bar (11.6 lbf/in ²)	0.8 bar (11.6 lbf/in ²)
Heating system nominal pressure	1.5 bar (21.7 lbf/in ²)	1.5 bar (21.7 lbf/in ²)
Maximum domestic water supply pressure	8 bar (116 lbf/in ²)	8 bar (116 lbf/in ²)
Minimum domestic water supply pressure	0.25 bar (3.6 lbf/in ²)	0.25 bar (3.6 lbf/in ²)
Maximum domestic hot water temperature	64°C	64°C
Maximum central heating temperature	85°C	85°C
Maximum domestic hot water output at 35° Δ T	9.4 L/min.	10.5 L/min.
Expansion vessel capacity	7 litres (1.53 gallons)	8 litres (1.76 gallons)
Expansion vessel pre-charge pressure	1.0bar (14.6 lbf/in ²)	1.0bar (14.6 lbf/in ²)
Minimum flow rate around the central heating circuit at 35 rise	776 L/hr.	1032 L/hr.
Electrical supply	230V~50Hz fused 5A	230V~50Hz fused 5A
Maximum power consumption	220 Watt	220 Watt
EN60529 IP clasification	IPX4D	IPX4D
Internal fuse rating on main PCB	2A	2A
Gas supply (governed meter only - NG)*	G20 - NG /G31 - Propane	G20 - NG /G31- Propane
Gas category	II ₂ H3P	II ₂ H3P
Inlet gas working pressure - NG	20 mbar	20 mbar
Heat input maximum	25.7 kW.	28.5 kW.
Heat output maximum	24.7 kW.	27.6 kW.
Heat input minimum	11 kW.	11 kW.
Heat output minimum	10.2 kW.	10.2 kW.
Usefull efficiency at 100% load	96%	96.8%
Usefull efficiency at 30% load	102.4%	103.3%
Burner injector NG / LPG (G31)	1.20 mm / 0.75mm	1.15 mm / 0.75mm
Burner pressure maximum NG**	12.5 mbar	14 mbar
Burner pressure minimum NG	2.5 mbar	2.3 mbar
SEDBUK rating	Band B 86.0%	Band 86.4%
NOx	Class 3	Class 3
Flue Type	C12-C32-C42-C52	C12-C32-C42-C52

* See Commissioning section for NG (G20) to LPG (G31) conversion

** Installation to (G31) Propane is by conversion kit only

14343

Boiler Components

14532

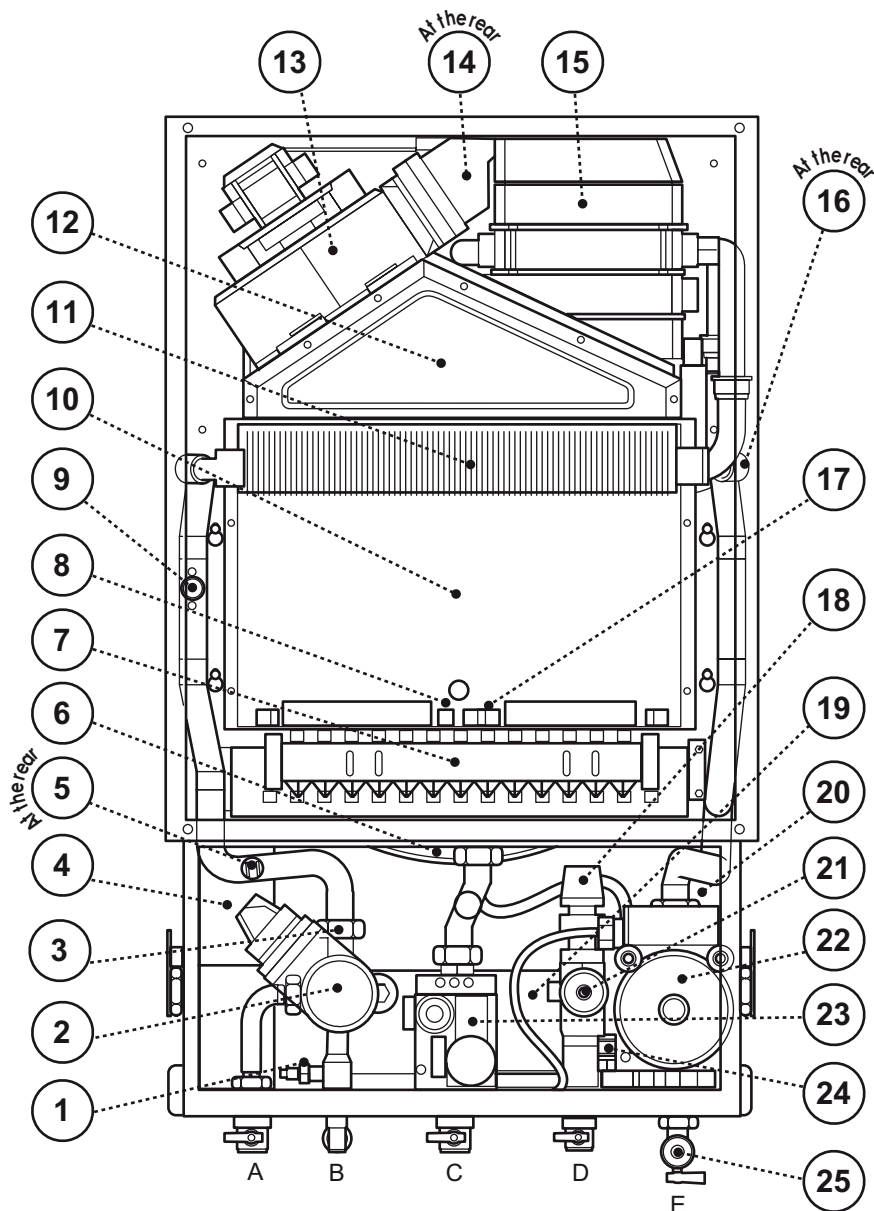

- A**- Heating Flow (22mm)
- B**- D.H.W. Outlet (15mm)
- C**- Gas Inlet (22mm)
- D**- Cold Water Inlet (15mm)
- E**- Heating Return (22mm)

Key

- 1 - D.H.W. Sensor
- 2 - Diverter Valve Motor
- 3 - Diverter Valve
- 4 - Condensate Trap
- 5 - Limit Thermostat
- 6 - Expansion Vessel (At rear of the boiler)
- 7 - Burner
- 8 - Flame Sensor Electrode
- 9 - C.H. Sensor (Heating Sensor)
- 10 - Combustion Chamber
- 11 - Primary Heat Exchanger
- 12 - Fan Hood
- 13 - Fan
- 14 - Air Pressure Switch
- 15 - Condensing Unit (Turbo heat exchanger)
- 16 - Overheat Safety thermostat
- 17 - Ignition Electrode
- 18 - Heating Circuit- Pressure Safety Valve
- 19 - Secondary Heat Exchanger
- 20 - Automatic Air Vent
- 21 - Water Pressure Switch/Sensor
- 22 - Pump
- 23 - Gas Valve
- 24 - D.H.W. Flow Sensor
- 25 - Filter Valve (Below the pump)

2 Boiler Dimensions and Hydraulic Schematic

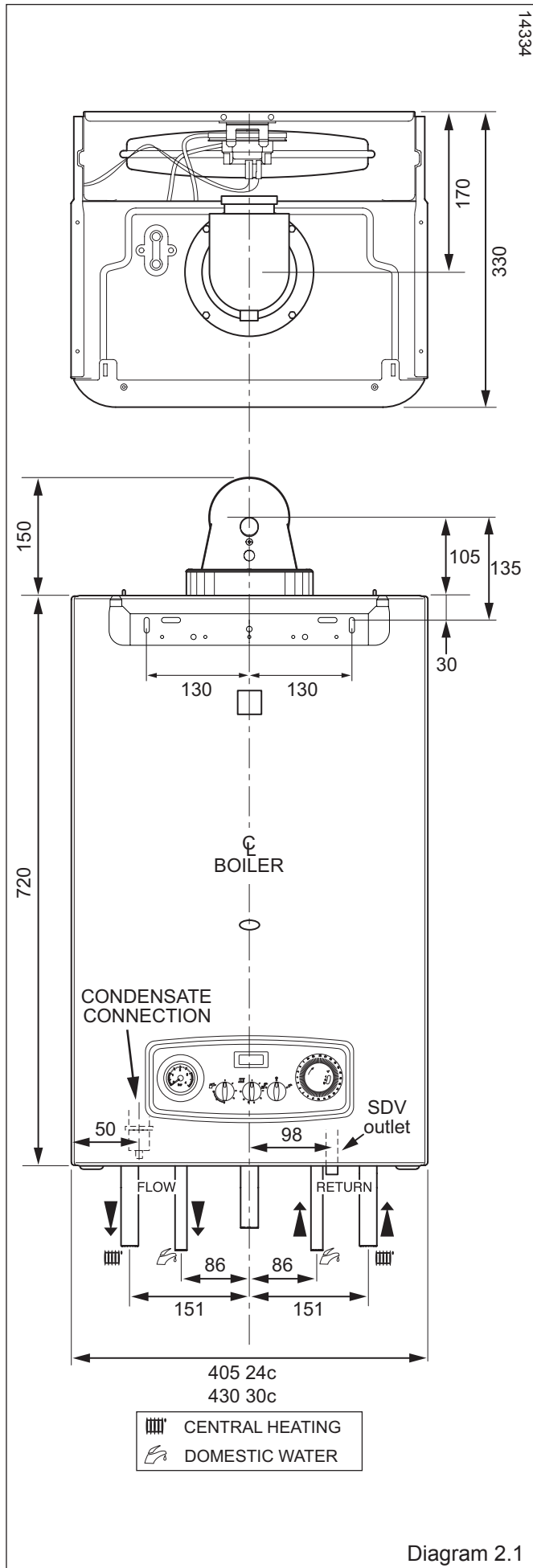

2.1 Boiler Dimensions and Hydraulic Schematic

All dimensions are given in millimetres (except as noted). The general arrangement of the boiler is shown in diagram 2.1 and the hydraulic and gas schematics diagrams, showing the central heating hydraulic circuit and domestic hot water hydraulic circuit in diagram 2.2. The data label is positioned on the control box back cover.

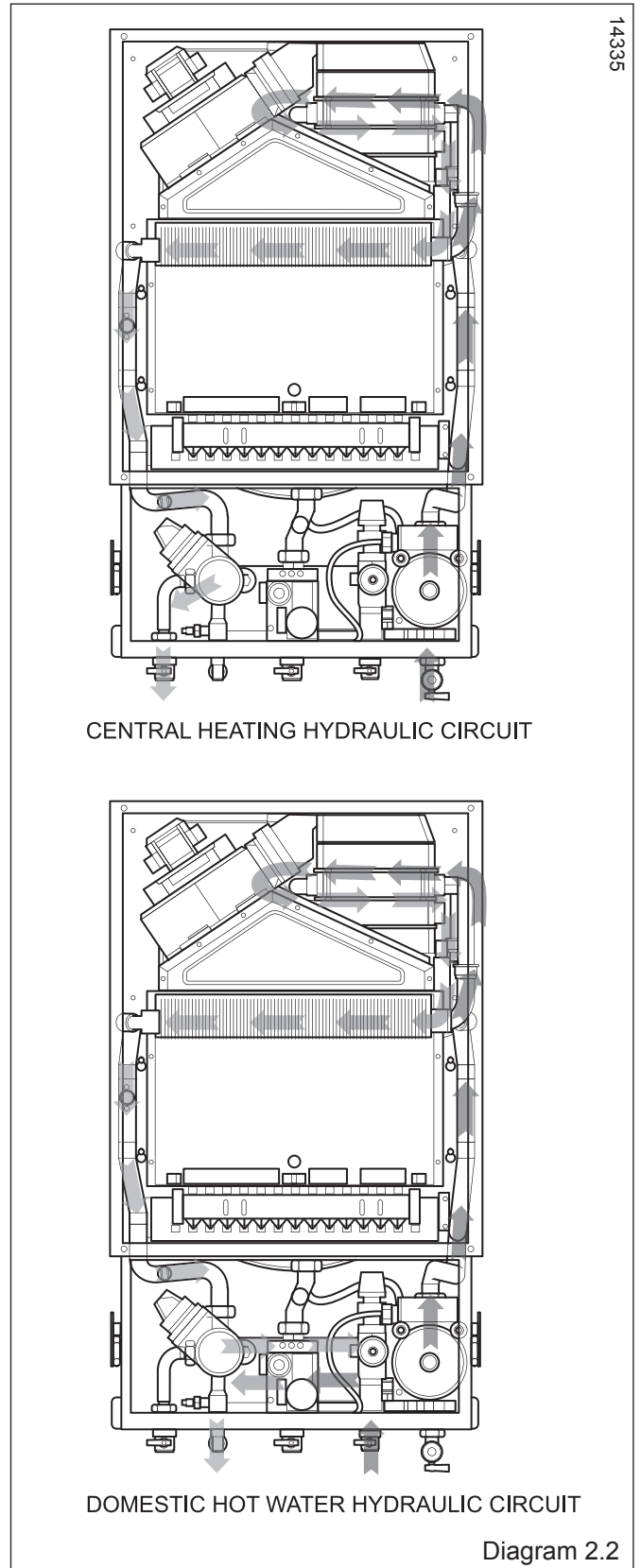

3 Boiler Location, Clearances and Ventilation

3.1 Location

This boiler is not suitable for outdoor installation. This boiler may be installed in any room, although particular attention is drawn to the installation of a boiler in a room containing a bath or shower where reference must be made to the relevant requirements.

This boiler is suitable for installation in bathroom zones 2 and 3.

In GB this is the current I.E.E. WIRING REGULATIONS and BUILDING REGULATIONS.

In IE reference should be made to the current edition of I.S.813 "Domestic Gas Installations" and the current ETCI rules.

3.2 Clearances

The boiler should be positioned so that at least the minimum operational and servicing clearances are provided, see diagram 3.1.

Additional clearances may be beneficial around the boiler for installation and servicing.

For flue installations where external access is not practicable, consideration should be given for the space required to insert the flue internally, which may necessitate clearance larger than those specified in diagram 3.1.

3.3 Timber Frame Buildings

If the boiler is to be installed in a timber frame building it should be fitted in accordance with the Institute of Gas Engineers document IGE/UP/7/1998. If in doubt seek advice from local gas undertaking or Glow-worm.

3.4 Combustible Material

The boiler and flue are suitable for installation onto and through combustible materials provided that:-

- 1) The boiler must be sited at least 1m away from flammable materials and heat sensitive walls must be protected by appropriate insulation.
- 2) Minimum 5 mm clearance is maintained around the circumference of the flue (air intake).
- 3) The combustible surface and fixings are suitable for supporting the load.
- 4) The minimum clearances from the boiler case are maintained.

3.5 Room Ventilation

The boiler is room sealed so a permanent air vent is not required.

3.6 Cupboard or Compartment Ventilation

If the boiler is installed in a compartment there must be purpose made ventilation for cooling purposes. Make sure the cupboard or compartment air vents are positioned to be clear of obstructions at all times. A compartment used to enclose the boiler must be designed and constructed specifically for this purpose. An existing cupboard or compartment modified for the purpose may be used. Refer to the current issue of BS6798 for guidance.

	HI	LO
Betacom 24c	128.5cm ²	128.5cm ²
Betacom 30c	142.5cm ²	142.5cm ²

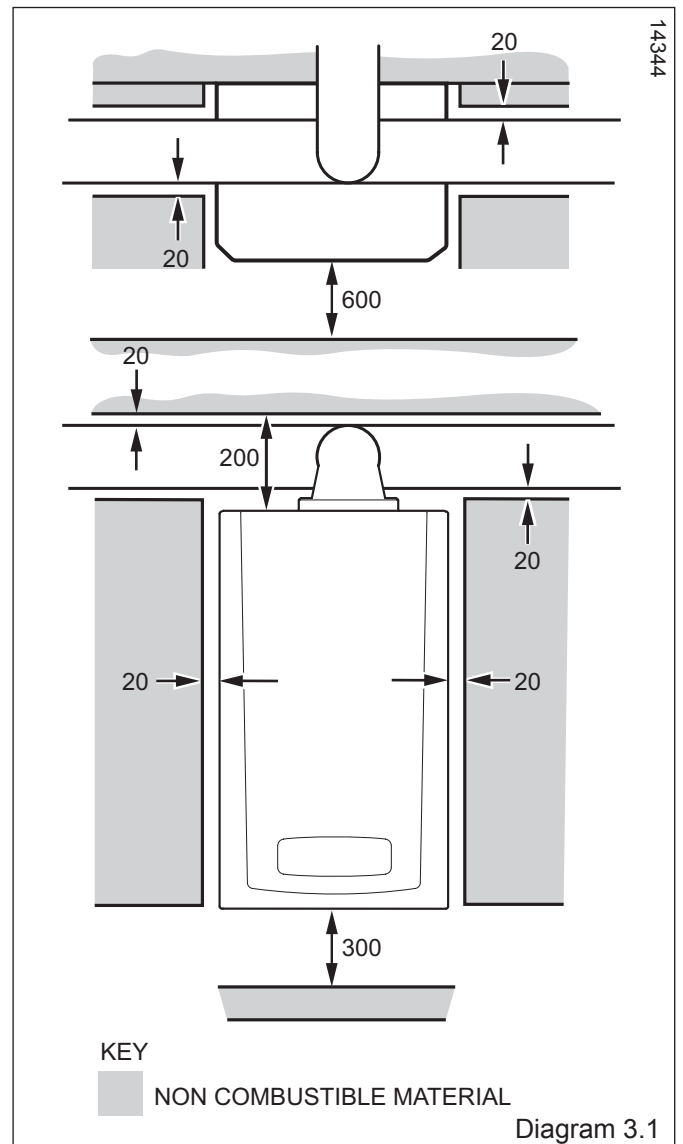

4 Flue Options and Terminal Clearances

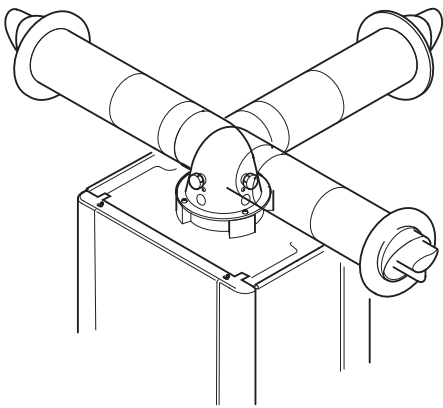

Top horizontal telescopic flue (Ø60/100)
Part No. A2043600 - Section 9, page 21

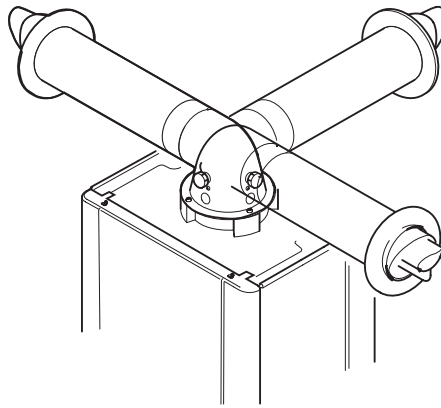

Top horizontal standard flue (Ø60/100)
Part No. A2043400 - Section 9, page 25

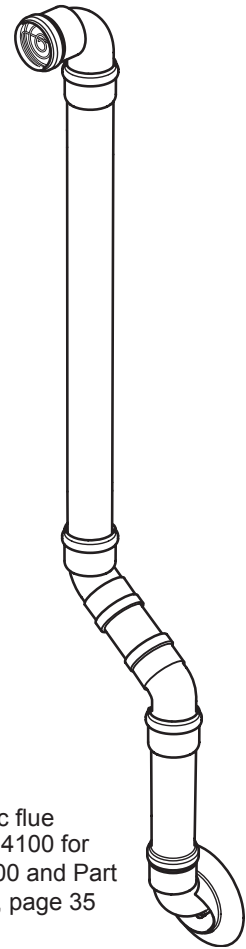

Plume Management Kit
basic set, white, concentric flue
(Ø60/100) - Part No. A2044100 for
use with Part No. A2043400 and Part
No. A2043600 - Section 9, page 35

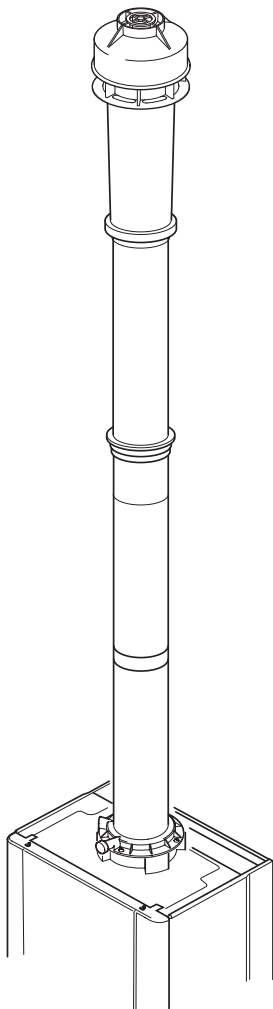

Vertical Flue
Vertical Flue Adapter, concentric flue (Ø60/100)
Part. No. A2024600
Vertical flue terminal kit, concentric flue (Ø60/100)
Part. No. 2000460480 - Section 9, page 29

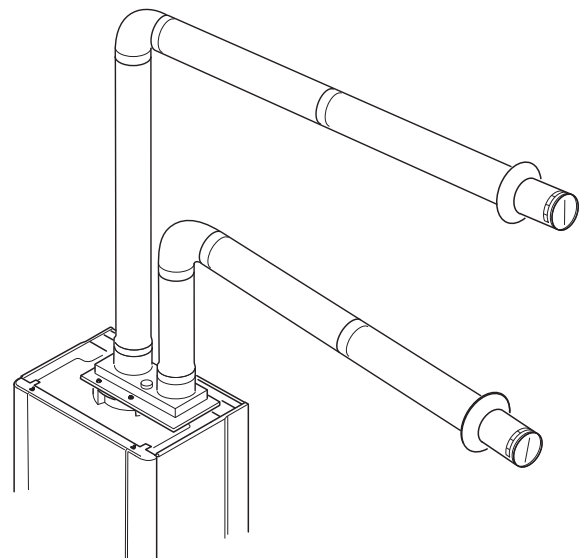

Twin Flue
Twin Flue Adapter, concentric flue (Ø80)
Part No. A2011000 - Section 9, page 32

Diagram 4.1

4 Flue Options and Terminal Clearances

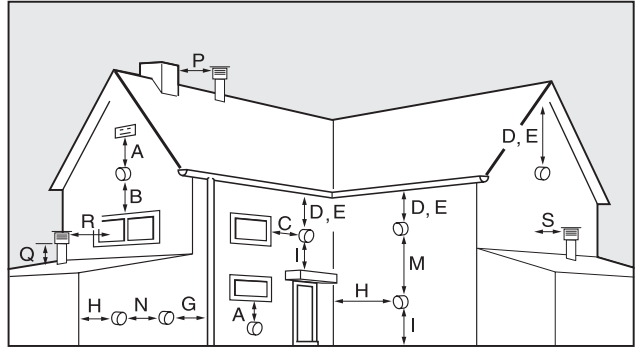

UNDER CAR PORT etc.

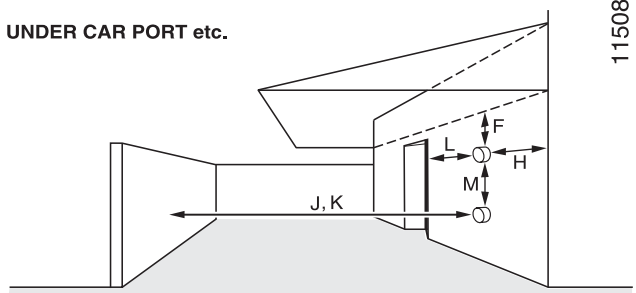

HORIZONTAL FLUES

A	DIRECTLY BELOW AN OPENING, AIR BRICK, OPENING WINDOWS	300
B	ABOVE AN OPENING, AIR BRICK, OPENING WINDOWS	300
C	HORIZONTALLY TO AN OPENING, AIR BRICK, OPENING WINDOWS	300
D	BELOW GUTTER, DRAIN/SOIL PIPE	25
E	BELOW EAVES	25
F	BELOW A BALCONY OR CAR PORT	25
G	FROM VERTICAL DRAIN PIPES AND SOIL PIPES	25
H	FROM INTERNAL/EXTERNAL CORNERS	25
H*	TO A BOUNDARY ALONGSIDE THE TERMINAL	300
I	ABOVE ADJACENT GROUND OR BALCONY LEVEL	300
J*	FROM SURFACE OR A BOUNDARY FACING THE TERMINAL	600
K	FACING TERMINALS	1200
L	FROM OPENING (DOOR/WINDOW) IN CAR PORT INTO DWELLING	1200
M	VERTICAL FROM A TERMINAL	1500
N	HORIZONTALLY FROM A TERMINAL	300

VERTICAL FLUES

P	FROM ANOTHER TERMINAL	600
Q	ABOVE ROOF LEVEL	300
R	FROM ADJACENT OPENING WINDOW	1000
S	FROM ADJACENT WALL TO FLUE	300

Diagram 4.2

4.1 Flue Options

There are various flue options to choose from as illustrated in diagram 4.1. The flue lengths and installation are described in section 9.

4.2 Flue Terminal Position

In GB the minimum acceptable siting dimensions for the terminal from obstructions, other terminals and ventilation openings are shown in diagram 4.2.

In IE the minimum distances for flue terminal positioning must be those detailed in I.S.813 "Domestic Gas Installations". The terminal must be exposed to the external air, allowing free passage of air across it at all times.

Being a condensing boiler some plumbing may occur from the flue outlet. This should be taken into consideration when selecting the position for the terminal.

Carports or similar extensions of a roof only, or a roof and one wall, require special consideration with respect to any openings, doors, vents or windows under the roof. Care is required to protect the roof if made of plastic sheeting. If the carport comprises of a roof and two or more walls, seek advice from the local gas supply company before installing the boiler.

H* and J* See diagram 4.2. These dimensions comply with the building regulations, but they may need to be increased to avoid wall staining and nuisance from plumbing depending on site conditions.

4.3 Terminal Guard

A terminal guard is required if persons could come into contact with the terminal or the terminal could be subject to damage.

If a terminal guard is required, it must be positioned to provide minimum of 50mm clearance from any part of the terminal and be central over the terminal.

The guard should be similar to that shown in diagram 4.3.

A suitable guard is manufactured by: -

Tower Flue Components
 Morley Rd.
 Tonbridge
 Kent TN9 1RA.
 Size: 280mm x 280mm x 270mm.

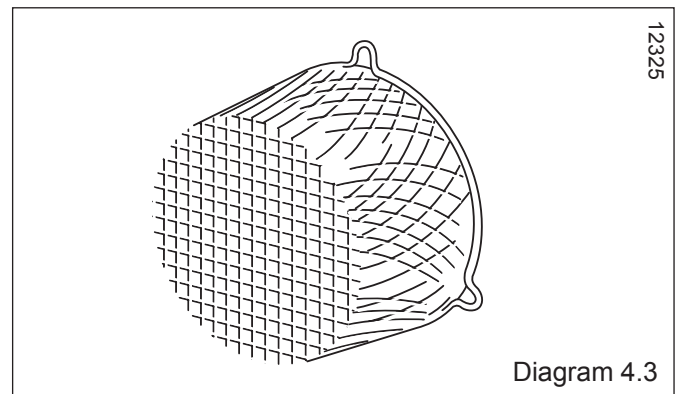

Diagram 4.3

12325

5 Water System - Heating

5.1 General

The boiler is designed to operate on fully pumped, pressurised sealed systems operating at a maximum of 3bar pressure and maximum design flow temperature of 85°C.

5.2 Safety Valve

The safety valve is an integral part of the boiler and it cannot be adjusted. The pipe from the safety discharge valve must not discharge above an entrance, window or any type of public access area.

5.3 Expansion Vessel

The boiler's integral expansion vessel with a capacity of 7 litres (1.5 gallons), is pre-charged to a pressure of 0.5bar and will accommodate a system volume of 125 litres at an average water temperature of 75°C and maximum system pressure of 3 bar. **NOTE:** The expansion vessel volume depends on the total water system volume and the initial system design pressure. **In GB,** Guidance on vessel sizing is also given in the current issue of BS5449 and BS7074 Part 1. **In IE,** current edition of I.S.813 "Domestic Gas Installations". If the system volume is more than 125 litres, an additional expansion vessel must be fitted to suit the size of the system. A typical installation of an additional pressure vessel is shown in diagram 5.1.

5.4 Flow Rate

If it is necessary to alter the flow rate, the system can be fitted with a lockable balancing valve in the main flow or return pipes shown as valve "A" in diagram 5.1. The flow rate through the boiler must not be allowed to fall below that given in Boiler Specification Table. The heating circuit should be designed and balanced to give a 20°C temperature rise across the boiler flow and return.

5.5 Water Treatment

Existing system- It is ESSENTIAL that prior to installing the new boiler the system is thoroughly flushed.

New system- For optimum performance after installation, the boiler and its associated central heating system should also be flushed.

Flushing should be carried out in accordance with BS7593: 2006 using a cleanser such as Sentinel X300 or X400, Fernox Restorer or Salamander corrosion guard cleaner.

IMPORTANT: Ensure all cleanser is removed from the whole system before adding an inhibitor.

Although the boiler is designed to inhibit the formation of scale, in hard water areas above 200mg/l, a proprietary scale reducer should be fitted in the cold water supply to the boiler. Failure to comply with this requirement may invalidate your guarantee. Refer to the current issue of BS 5449 and BS 7593 on the use of inhibitors in central heating systems.

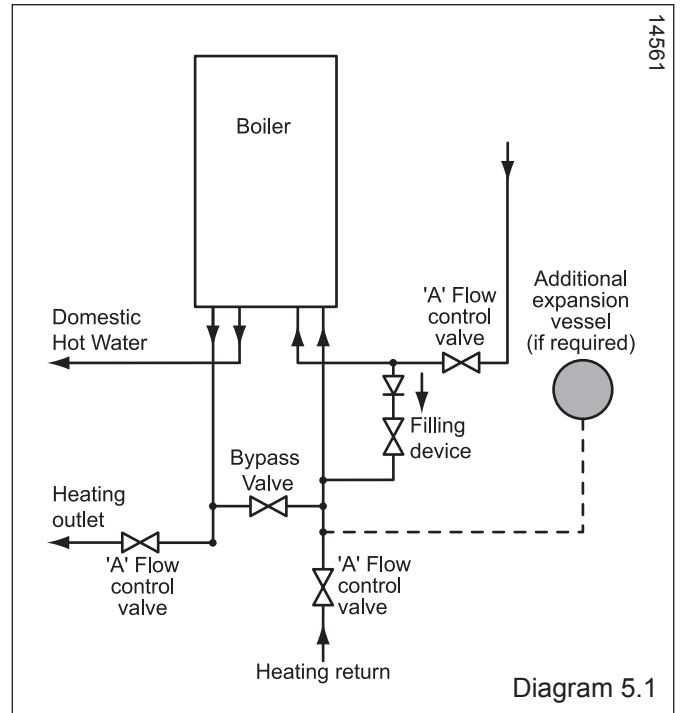

5.6 General

On installation it is important to ensure that the heat exchanger is not a natural collecting point for air and where possible, the system pipe work should have a gradient to ensure any excess air is carried naturally to other purpose made, air release points.

In high water volume systems or under floor heating systems where prolonged operation of the boiler is expected at temperatures below 60°C, a by-pass must be installed on the boiler outlet in order to prevent condensation forming inside the boiler body. Failure to comply with this requirement will invalidate the manufacturer's guarantee.

5.7 Bypass

The system's water must always be allowed to circulate whenever the circulation pump is running. A return by-pass must be provided.

NOTE: It is no longer permissible to use non-thermostatic radiator valves to allow by-pass through a radiator. Diagram 5.2 shows the pump head remaining for the heating system depending on the bypass setting and the speed setting of the pump, see section 12 Commissioning. Ensure that under no circumstances does the flow rate drop below the figure specified, refer to Boiler Specification Table.

5.8 Filling the Sealed System

With water via the filling loop, see diagram 5.3, (the filling loop is not supplied with the boiler).

5.9 Draining Points

Draining taps must be provided at all low points of the system, which will allow the entire system to be drained. Draining taps shall be to the current issue of BS2879.

5 Water System - Domestic Hot Water

5.10 Water Pressure

To obtain the best hot water performance from your boiler it is suggested that the cold water supply to the boiler is the first draw off from the incoming mains supply.

NOTE: The boiler will not operate unless there is a minimum pressure of 0.25 bar (3.6 lbf/in²) with a flow rate of 2.5 l/min. The minimum working pressure to obtain the maximum domestic flow is:-

24c 0.7 bar (10.15 lbf/in²)

30c 0.7 bar (10.15 lbf/in²)

The maximum working pressure of the domestic hot water circuit is 8 bar. If the cold water supply pressure exceeds this, then a pressure-reducing valve must be fitted in the supply to the boiler.

Where cold water mains are fitted with a water meter, check valve(s) or loose jumper stopcock, a domestic hot water mini-expansion vessel may need to be fitted.

To obtain the best hot water performance from your boiler it is suggested that supplies to faucets are run in 15mm copper, as short as possible and where practical, be insulated to reduce heat loss.

5.11 'Hard' Water Areas

The temperatures within the heat exchanger are limited by the boiler control system to minimise scale formation within the hot water pipework. However, in areas where the water is 'hard' (i.e. more than 200mg/litre), it is recommended that the hot water setting is reduced and that a scale reducer is fitted, refer to the manufacturer's instructions or consult the local water company for additional advice.

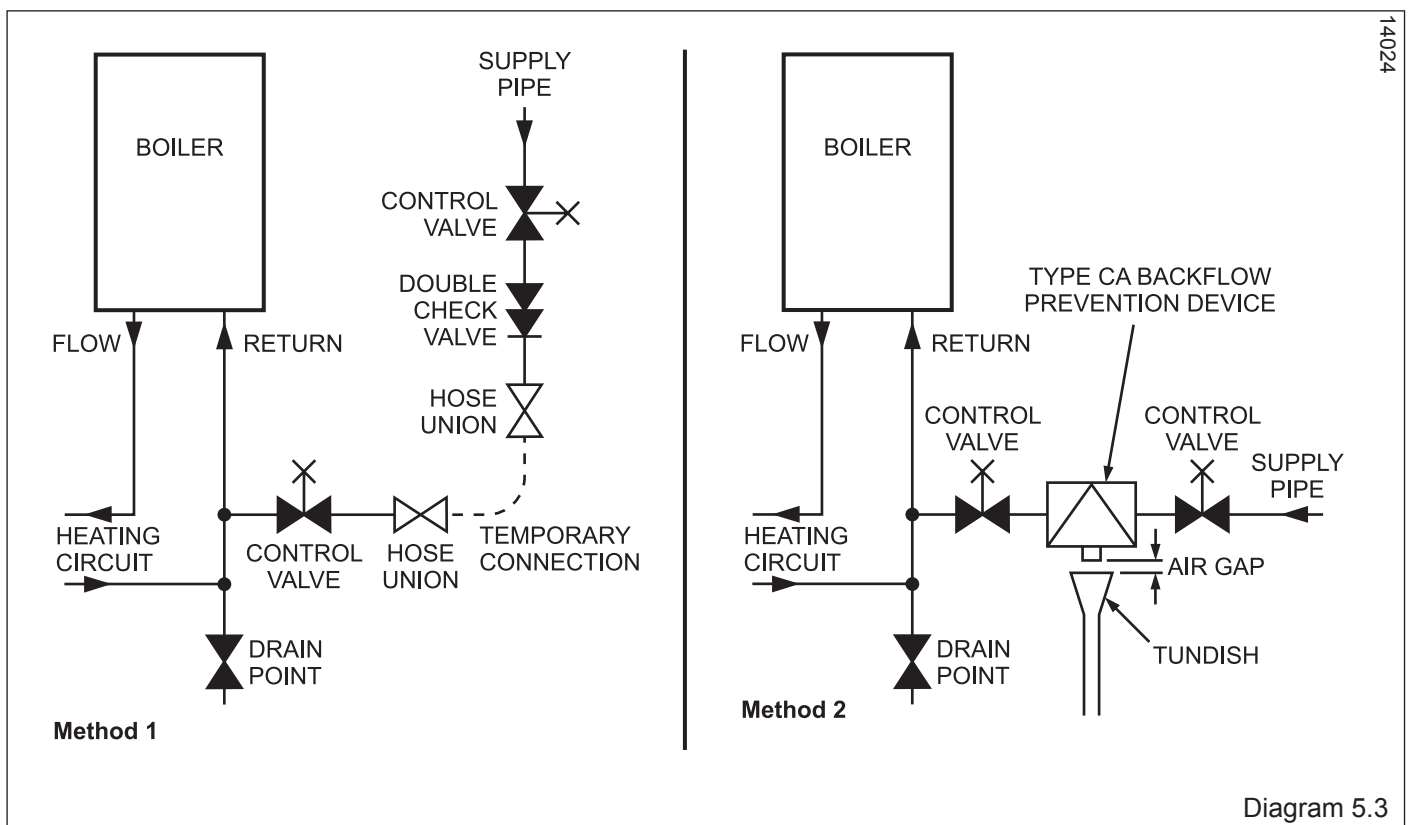
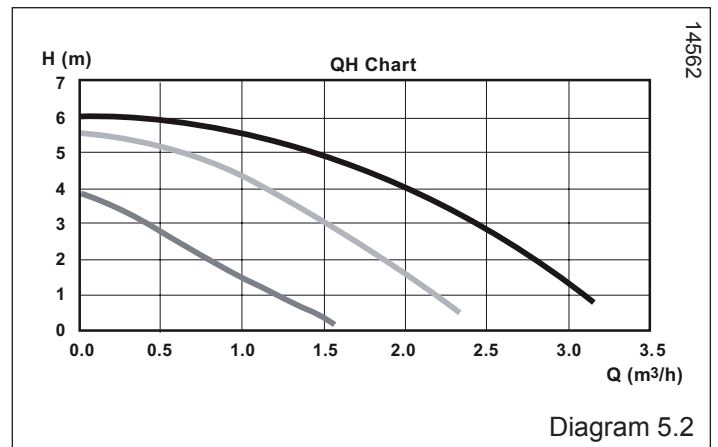

6 Installation Preparation

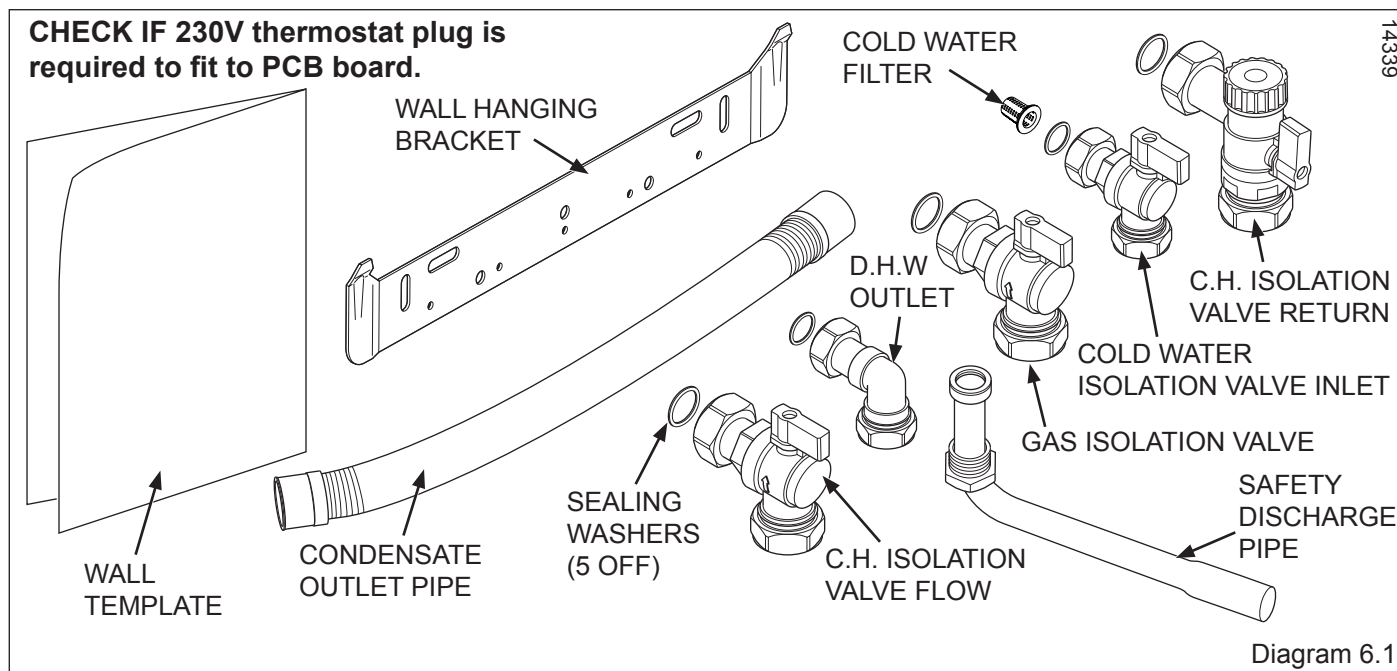

6.1 Appliance Pack

Please check the contents of the carton: Appliance, Isolation Valves, Wall Hanging Bracket, Wall Template, Service Installation and User Manual, Guarantee Card and Benchmark Log Book, see diagram 6.1. (Literature and appliance not illustrated)

Handling

IMPORTANT: With regards to the Manual Handling Operations, 1992 Regulations, the following lift operation exceeds the recommended weight for a one man lift, refer to section 17 Manual Handling.

To remove the appliance, refer to diagram 6.2.

1. Carefully slit or remove the sealing tape being careful not to scratch the appliance door.
2. Fully open the carton lid and remove any instructions and components.
3. Read the instructions carefully before installation of the appliance.
4. Roll the carton onto its open face.
5. Lift the carton free of the inner packaging.
6. Remove the mounting bracket and valve package.

7. Stand the boiler on its base within the expanded polystyrene block and remove the top packaging piece.

8. If you wish to remove the expanded polystyrene base lie the appliance on its back to do so.

6.2 Site Requirements

The boiler mounting wall should be suitable for the weight of the appliance and be true and flat.

NOTE: Due to the varied site conditions we do not supply fixings and advise that the installer should supply those which are suitable.

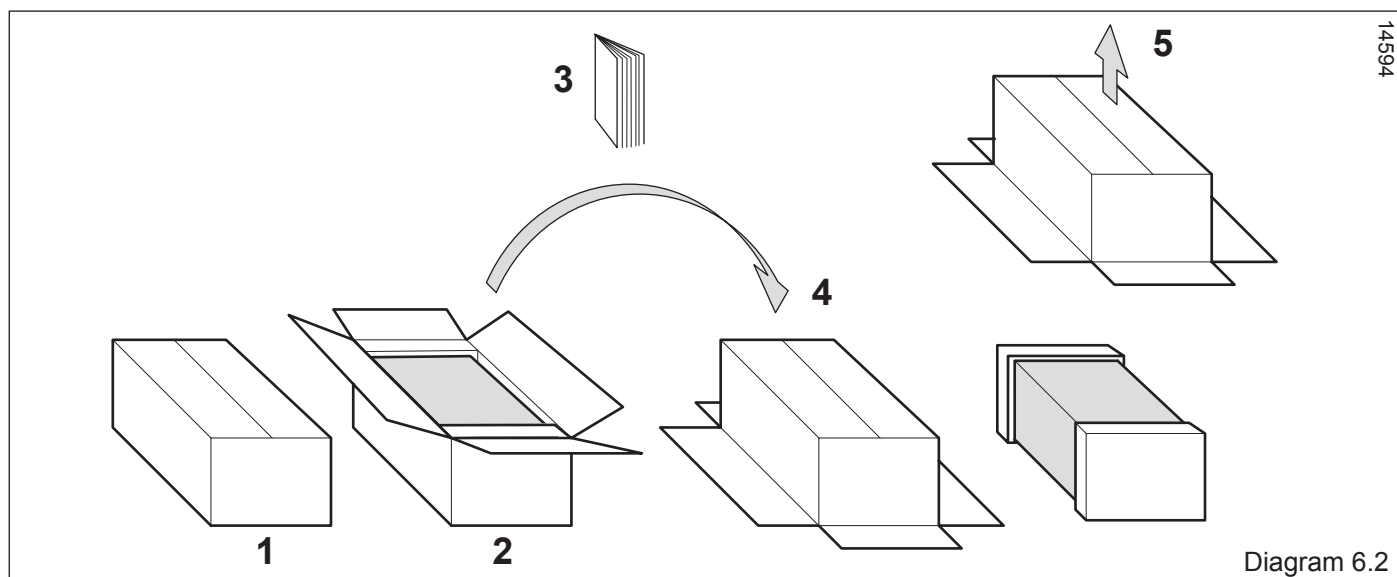

6 Installation Preparation

6.3 Wall Template

Take the wall template from the document pack and place in the desired position on the wall, giving due consideration to the required boiler clearances, see section 3, and the flue you are fitting.

Mark the position of the flue centre, if fitting a side flue, extend the flue centre line into the corner then 170mm along the adjacent wall, see diagram 6.3.

For extended side flues, the flue hole centre should be determined by extending the dashed inclined line on the template to the side wall, then 149mm along the adjacent wall, see diagram 6.2. This dashed line is drawn at 44mm/metre (2.5°) rise from the boiler.

To allow for the flue passing through the wall at this angle a 125mm hole should be drilled irrespective of internal or external installation.

Remove the wall template whilst drilling the flue hole.

6.4 Flue Hole Cutting

External access flue installation can use a 105mm diameter core drill.

Internal access only flue installation will need a 125mm diameter core drill.

NOTE: The flue is designed with an internal fall of 44mm/metre (2.5°), therefore the hole can be drilled horizontally. If flue extension pipes are to be used then a core drill size of 125mm is required. This will allow the extension pieces to slope at 44mm/metre (2.5°) towards the boiler.

6.5 Wall Hanging Bracket Assembly

The Wall Hanging Bracket is supplied in the main boiler packaging.

Reposition the wall template over the flue hole and mark the position of the fixing holes for the hanging bracket.

NOTE: Due to the varied site conditions we do not supply fixings and advise that the installer should supply those which are suitable.

Drill fixing holes using a 8.5mm. drill bit and insert suitable wall plugs. Secure the wall hanging bracket to the wall.

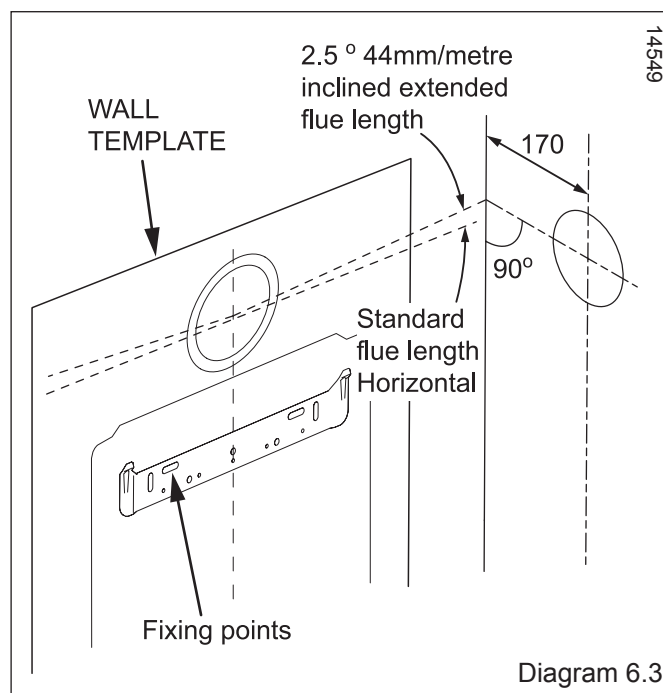

7 Boiler fixing, Gas / Water / Safety Discharge Connections

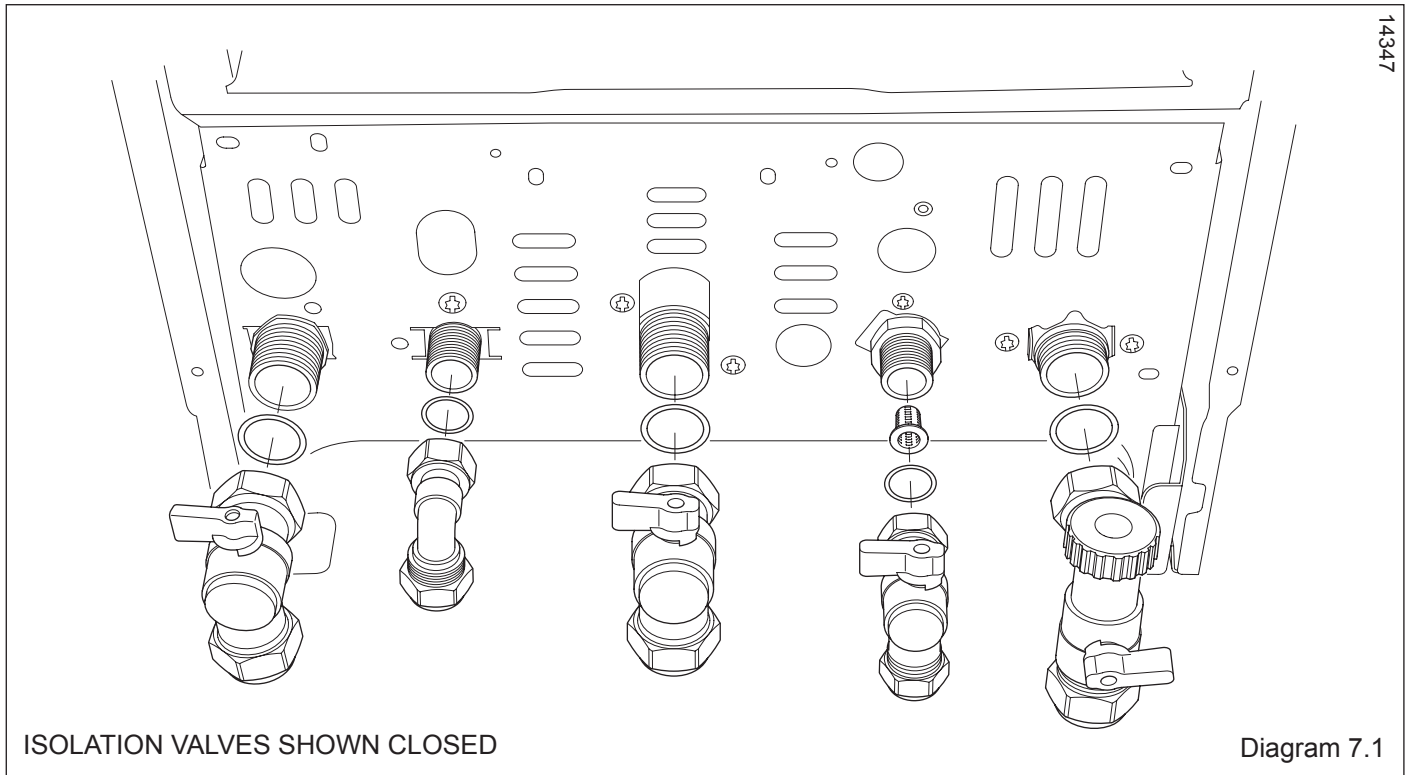

7.1 System connection

Connect the isolation valves including sealing washers and cold water inlet filter to the boiler ensuring the washers are fitted correctly, see diagram 7.1. Make sure the isolation valves are closed.

7.2 Safety Discharge Pipe

Connect the safety discharge pipe, see diagram 7.2. This must be extended, using not less than 15mm o.d. pipe, to discharge, in a visible position, outside the building, facing downwards, preferably over a drain. To ease future servicing it is advisable to use a compression type fitting to extend the safety discharge valve tube. The pipe must have a continuous fall and be routed to a position so that any discharge of water, possibly boiling, or steam cannot create any danger to persons, damage to property or external electrical components and wiring.

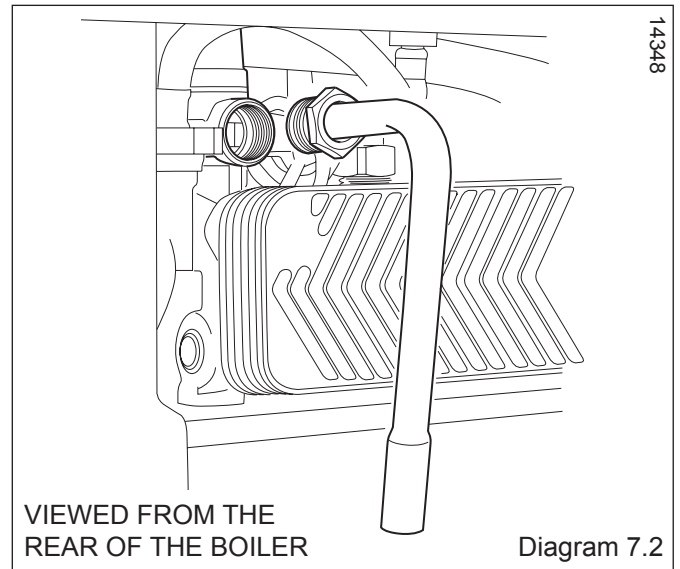

7.3 Boiler Hanging

Lifting the boiler into position, lean the top of the boiler slightly to the wall and position just above the hanging bracket. Lower the boiler slowly onto the hanging bracket making sure the boiler is located in the boiler mounting slots, see diagram 7.3. **IMPORTANT:** With regards to the Manual Handling Operations, 1992 Regulations, the following lift operation exceeds the recommended weight for a one man lift, refer to section 17 Manual Handling.

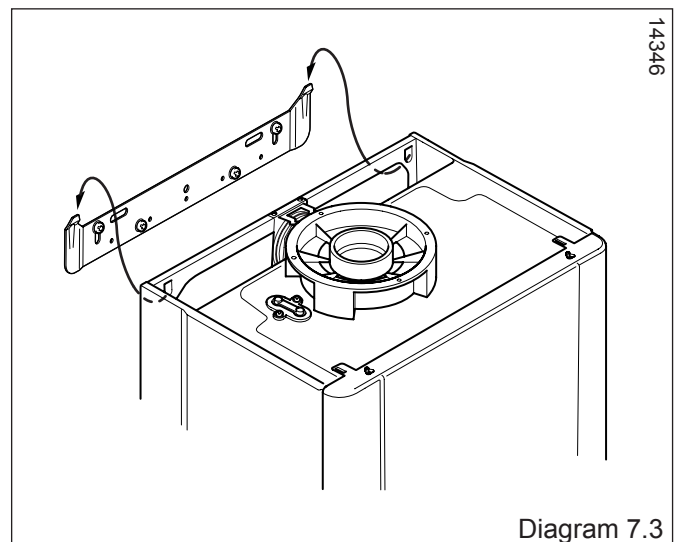

8 System Pipes and Condensate Connections

8.1 Condensate Trap Connection

A flexible condensate outlet pipe is supplied and should be used to couple the condensate trap to a 22mm to 25mm O.D. non corrosive plastic pipe (overflow pipe), see diagram 8.1.

NOTE: the pipe should have a fall of a least 2.5° 44mm/metre away from the boiler.

Condensate should, if possible be discharged into the household internal drainage system. If this is not practicable, discharge can be allowed into the external household drains or a purpose designed soak away, refer to diagram 8.3.

It is recommended that any external condensate drain pipe is insulated and also preferably of 32mm diameter, to prevent freezing in adverse weather conditions.

It is not necessary to provide air breaks or extra traps in the discharge pipe as there is already a 75mm high trap inside the boiler. Fitting an extra trap may cause the boiler siphon to work incorrectly.

Refer to BS5546 or BS6798 for advice on disposal of boiler condensate.

8.2 System Pipes Connection

Plumb gas and water system pipe work up to the isolation valves using olives supplied, see diagram 8.2.

Do not subject isolation valves to heat.

The whole of the gas installation, including the meter, should be inspected, tested for tightness and purged in accordance with the current issue of BS6891 and in IE the current edition of I.S.813 "Domestic Gas Installations".

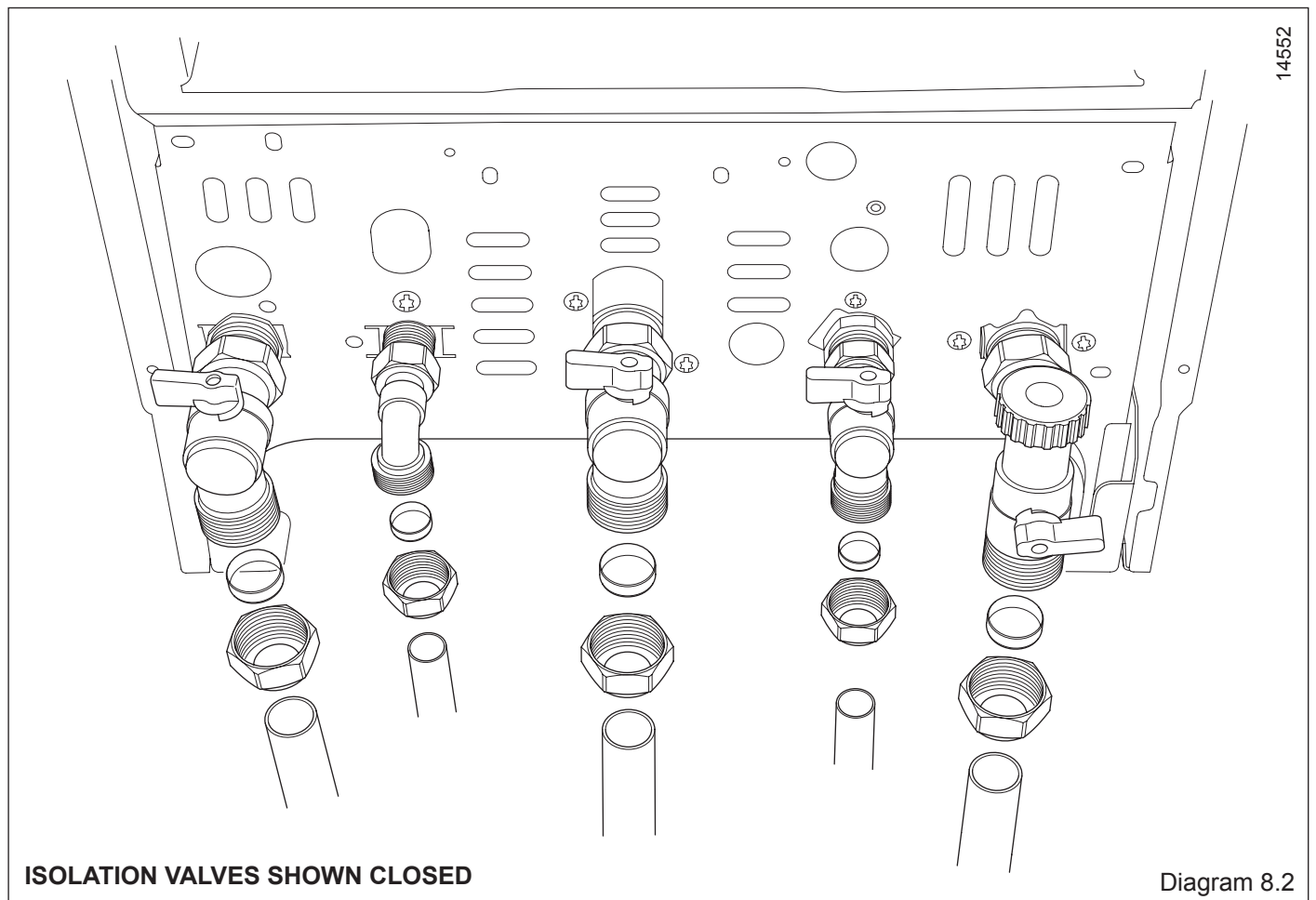
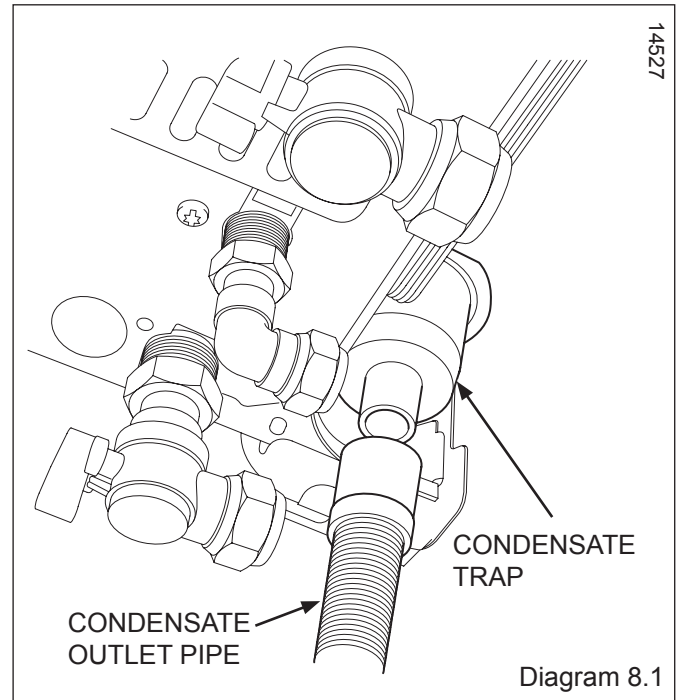

8 Condensate Connections

13000

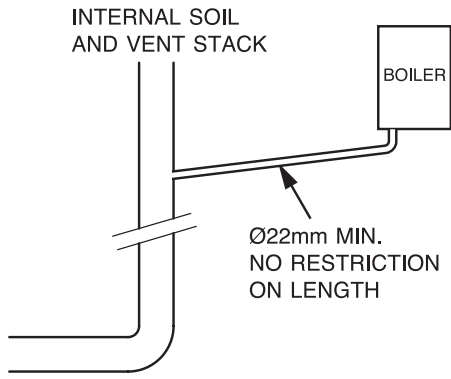

Internal Soil and Vent Pipe

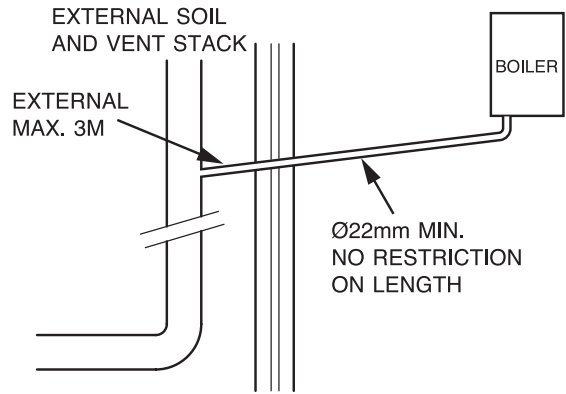

External Soil and Vent Pipe or Rainwater Pipe

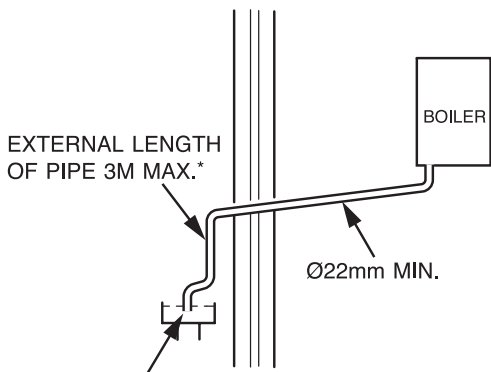

EXTERNAL LENGTH OF PIPE 3M MAX.*
 Ø22mm MIN.
 OPEN END OF PIPE DIRECT INTO GULLEY BELOW GROUND BUT ABOVE WATER LEVEL

*NOTE: FOR EXTENDED PIPE RUNS 32mm DIA. PIPE SHOULD BE USED.

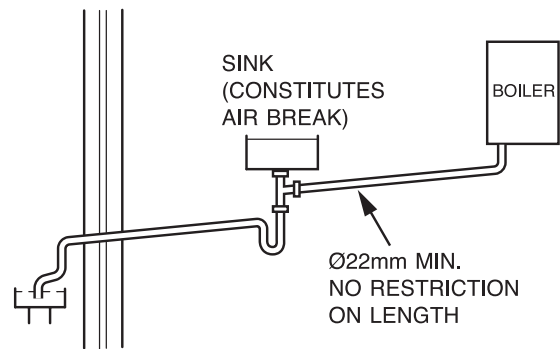

Internal Termination into Combined Sink Waste

External Termination to a Gully or Hopper

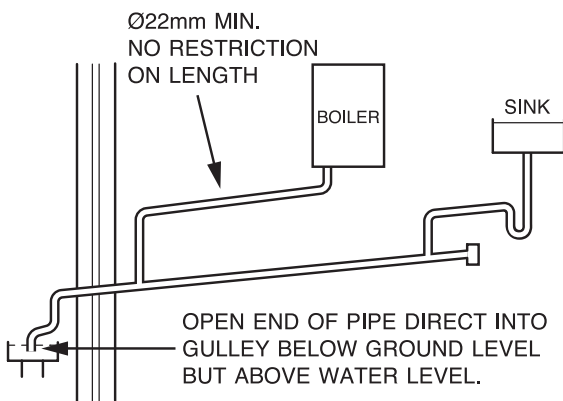

Internal Termination Downstream of Sink Waste

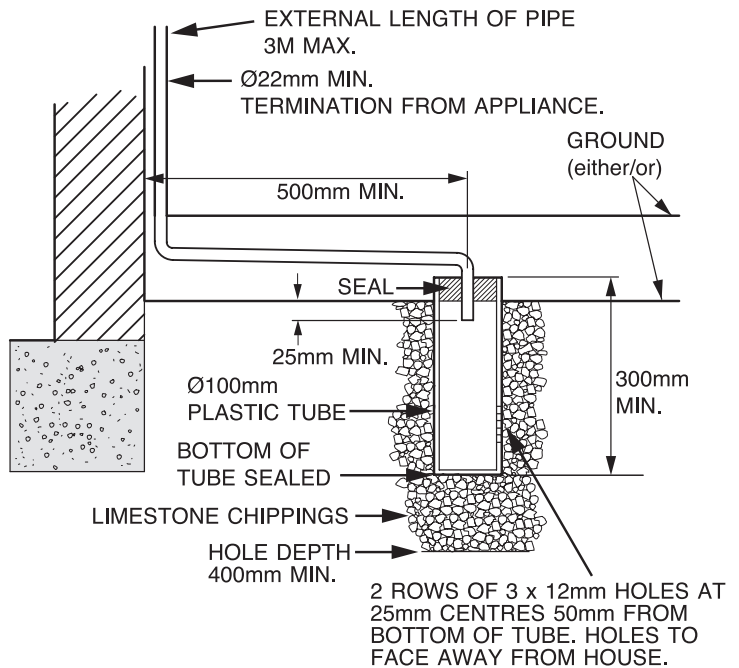

External Termination into Soakaway

NOTE: PIPEWORK SHOULD ALWAYS FALL AWAY FROM BOILER BY AT LEAST 2.5° 44mm FOR EVERY 1M.

Diagram 8.3

9 Telescopic Flue - Length, Preparation and Installation

Horizontal Telescopic Flue

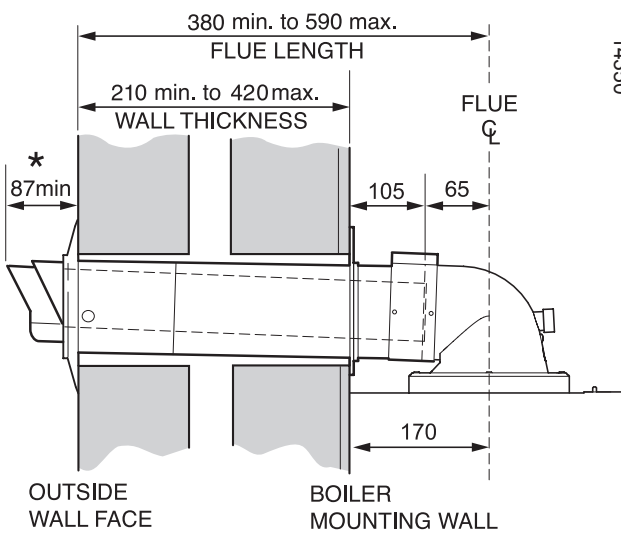

* NOTE. If necessary, it is permitted to increase this dimension to 600mm max.

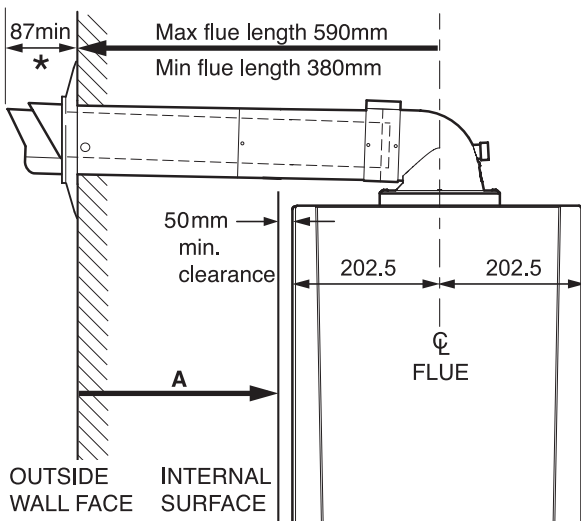

A	
Max. distance from outside wall face to min clearance. LH - 337.5mm RH - 337.5mm	Min. distance from outside wall face to min clearance. LH - 127.5mm RH - 127.5mm

Diagram 9.1

9.1 Flue Length and Restrictors

The maximum permissible horizontal flue length is 2.5 metres plus the flue terminal assembly, this can be achieved by use of the accessories, see diagram 9.3.

However should an additional 90° or 2 x 45° elbows be used then the length MUST be reduced by 1 metre.

The diagram 9.1 shows the length achievable by using the kit A2043600.

When extension pipes are used the flue system must be designed to have a continuous fall to the boiler of at least 2.5° 44mm/metre to allow condensate to run back into the boiler and out via the condensate drain.

The flue can be installed from inside the building, when access to the outside wall face is not practicable.

The flue restrictor is supplied in the documentation pack, the correct size is supplied for the boiler output:-

Betacom 24c - 83mmØ

Betacom 30c - 85mmØ

The flue restrictor must be fitted in the flue adaptor for, concentric flue installations less than 1 metre and twin flue installations less than 2 metres equivalent length.

Full instructions are provided in the documentation pack.

9 Telescopic Flue - Length, Preparation and Installation

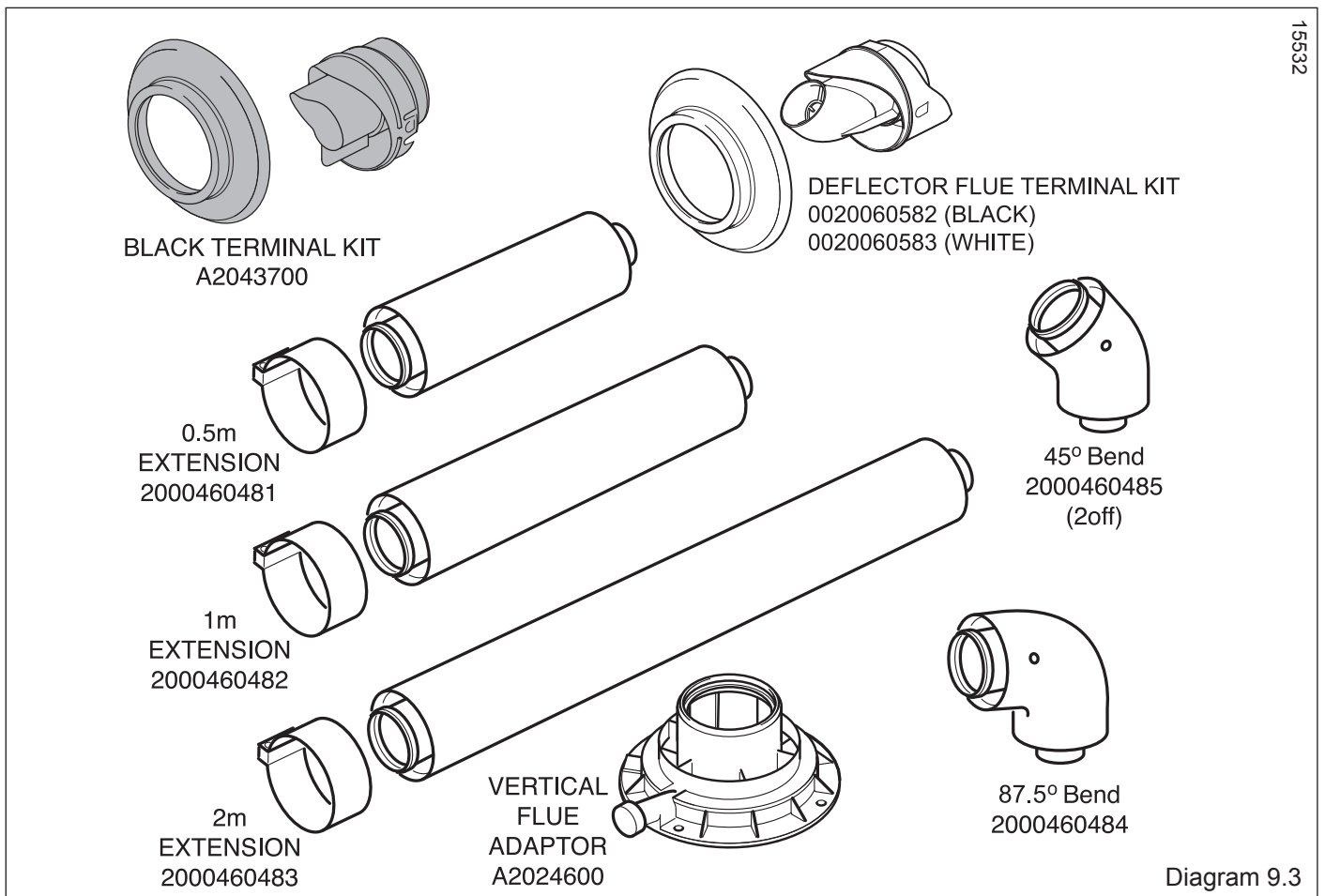
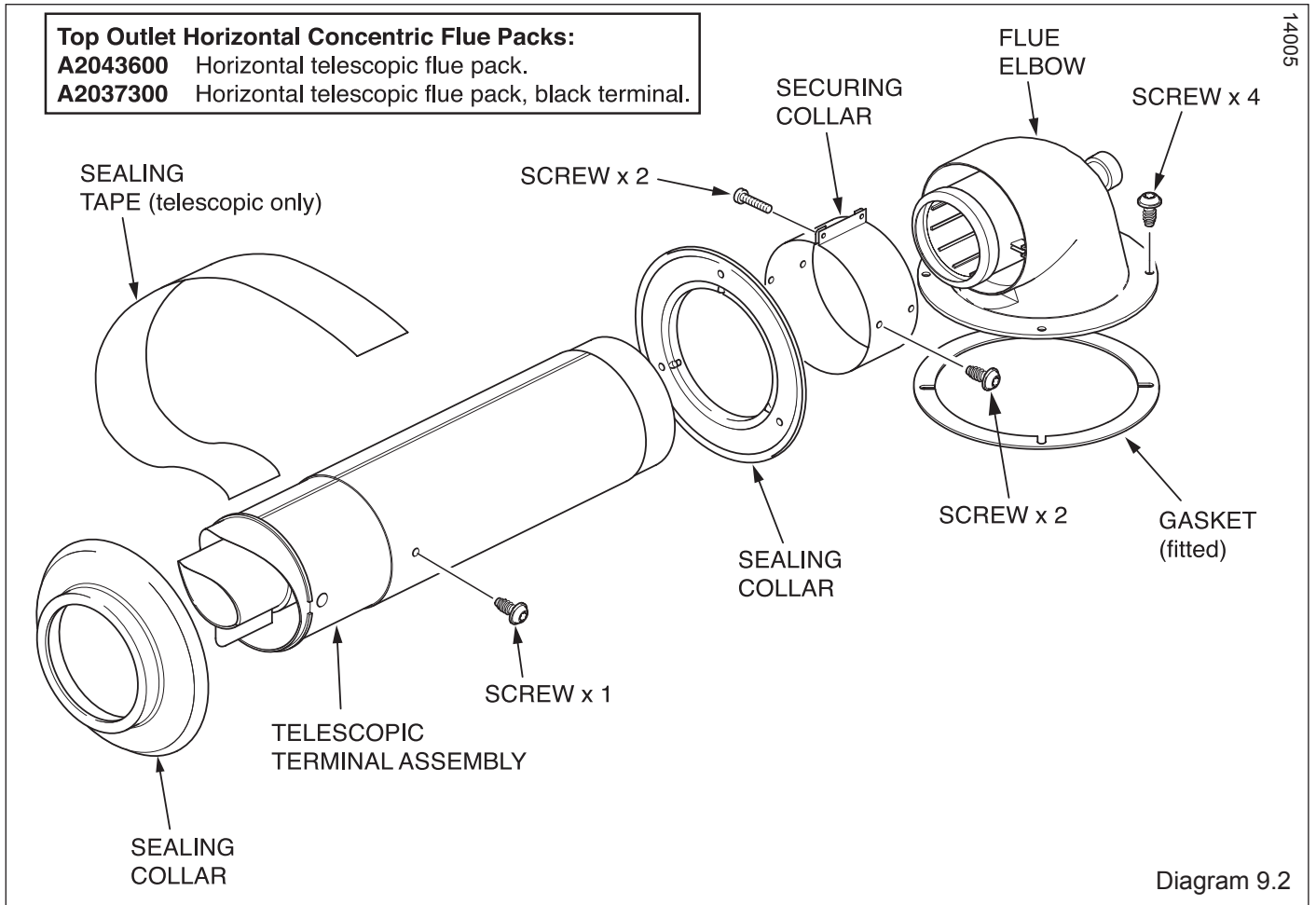

9 Telescopic Flue - Length, Preparation and Installation

9.2 Horizontal Telescopic Flue - A2043600

Refer to diagram 9.2 for kit contents.

9.3 REAR Flue

If a wall thickness is between 210mm min. to 420mm max. then the flue can be used without extensions.

Temporarily secure the flue elbow, measure the distance from the outside wall to the butt joint, see diagram 9.4. If the measurement 'Y' exceeds 525mm, then the appropriate length of extension pipe is required.

If the dimension is less than 315mm DO NOT cut the flue, it can project to a maximum of 600mm, refer to diagram 9.5. If this is not desirable then a Standard flue MUST be used and cut to length.

9.4 SIDE Flue

Temporarily secure the flue elbow, measure the distance from the outside wall to the butt joint, see diagram 9.6. If the measurement 'Y' exceeds 525mm, then the appropriate length of extension pipe is required.

If the dimension is less than 315mm DO NOT cut the flue, it can project to a maximum of 600mm, refer to diagram 9.5. If this is not desirable then a Standard flue MUST be used and cut to length.

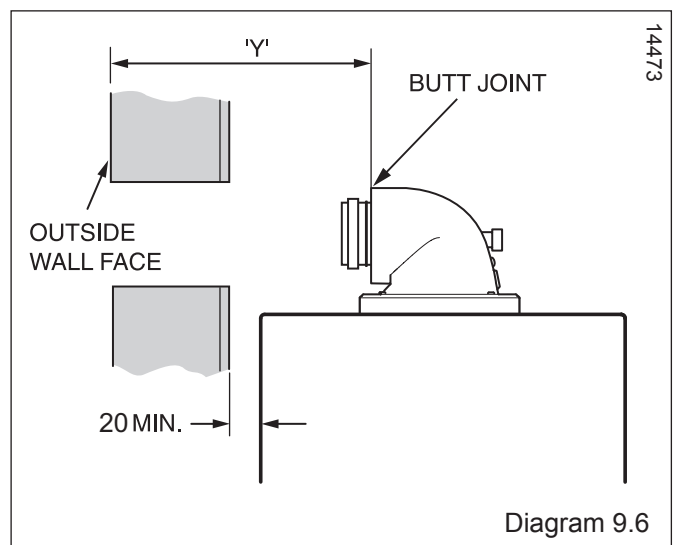
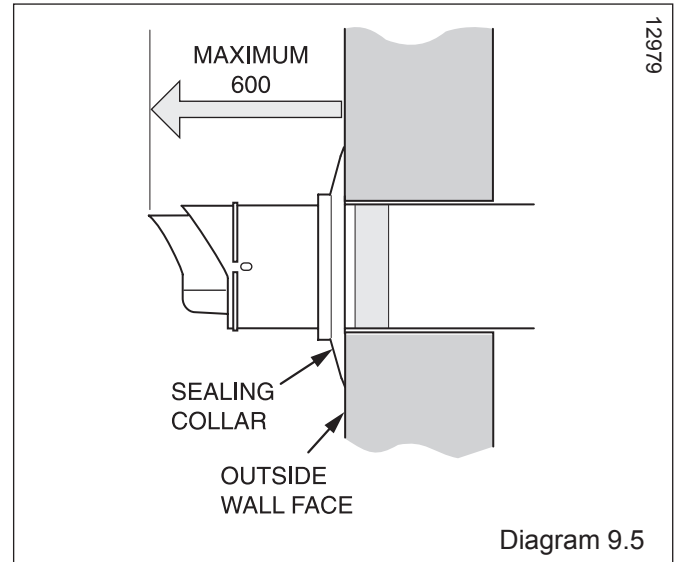
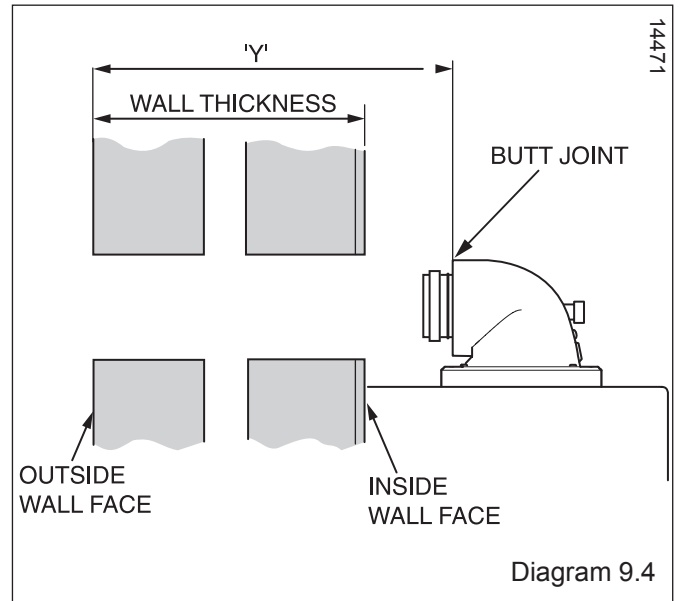

9 Telescopic Flue - Length, Preparation and Installation

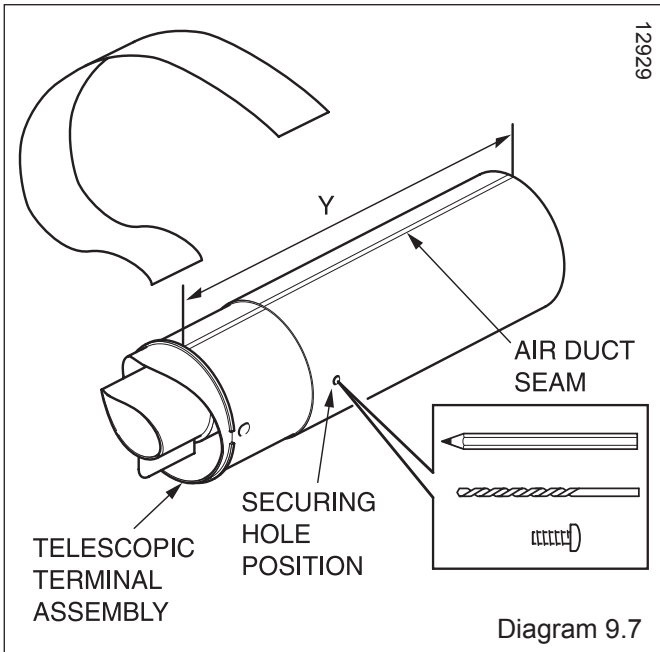

9.5 Flue Fitting

With the air duct seams aligned and the flue set to the required length 'Y', mark the securing hole position in the air duct. Drill a 3mm diameter hole at this position, take care not to pierce the inner flue duct. Secure with screw provided and tape the joint, see diagram 9.7.

Fit the sealing collar onto the locating ring on the flue terminal, see diagram 9.8.

With the flue elbow removed, push the flue assembly into the wall, externally or internally, until the end of the assembly protrudes a short way from the inside face of the wall. This will enable the internal trim ring (if required) to be positioned and allow the flue assembly to be drawn back up to the flue elbow.

Secure the flue elbow in position on top of the boiler with the four screws supplied.

Draw the flue assembly from wall and engage the flue duct into the elbow and butt fit between the air duct and flue elbow. Check the correct alignment of the flue.

Fit the securing collar in position, mark through two of the pre drilled holes in the securing collar. Remove securing collar and drill two 3mm diameter holes one in the elbow and one in the air duct, take care not to pierce the inner flue duct. Fit the securing collar and secure with screws provided, see diagram 9.9.

Slide the internal trim ring back against the wall, securing in place with a small amount of sealant if required.

The cut ducts must be de-burred and all filings and debris removed.

Insert the flue duct into the air duct terminal assembly, remembering to engage the catch within the terminal.

NOTE: If the seals require lubricant to ease installation, do not use mineral oils or grease, water is recommended.

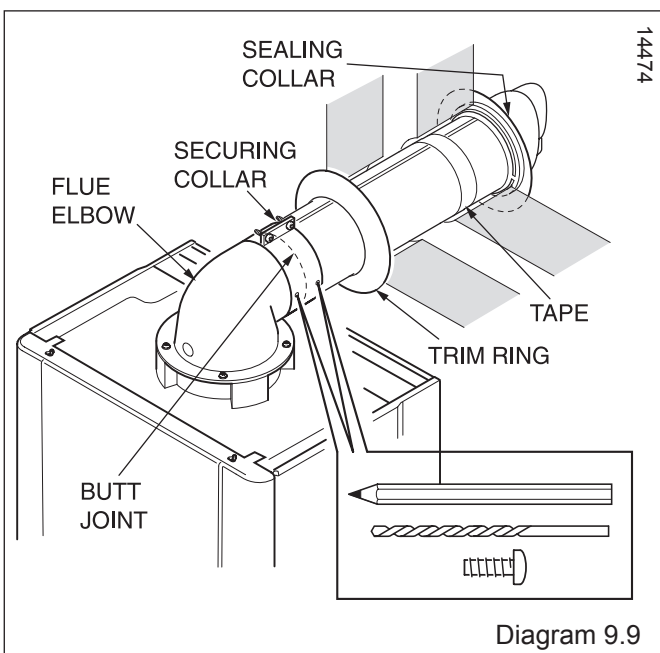
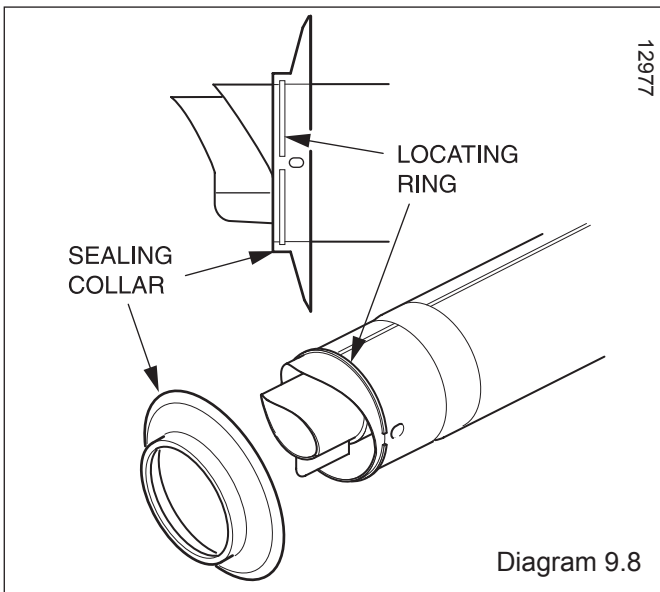

9 Standard Flue - Length, Preparation and Installation

9.6 Flue Length

The maximum permissible horizontal flue length is 5.6 metres for Betacom 24c and 4.6 metres for Betacom 30c, this can be achieved by use of the accessories, see diagram 9.12. However should additional 90° or 2 x 45° elbows be used then the length MUST be reduced by 1 metre. The diagram 9.10 shows the length achievable by using the kit A2043400.

When extension pipes are used the flue system must be designed to have a continuous fall to the boiler of at least 2.5° 44mm/metre to allow condensate to run back into the boiler and out via the condensate drain. The flue can be installed from inside the building, when access to the outside wall face is not practicable.

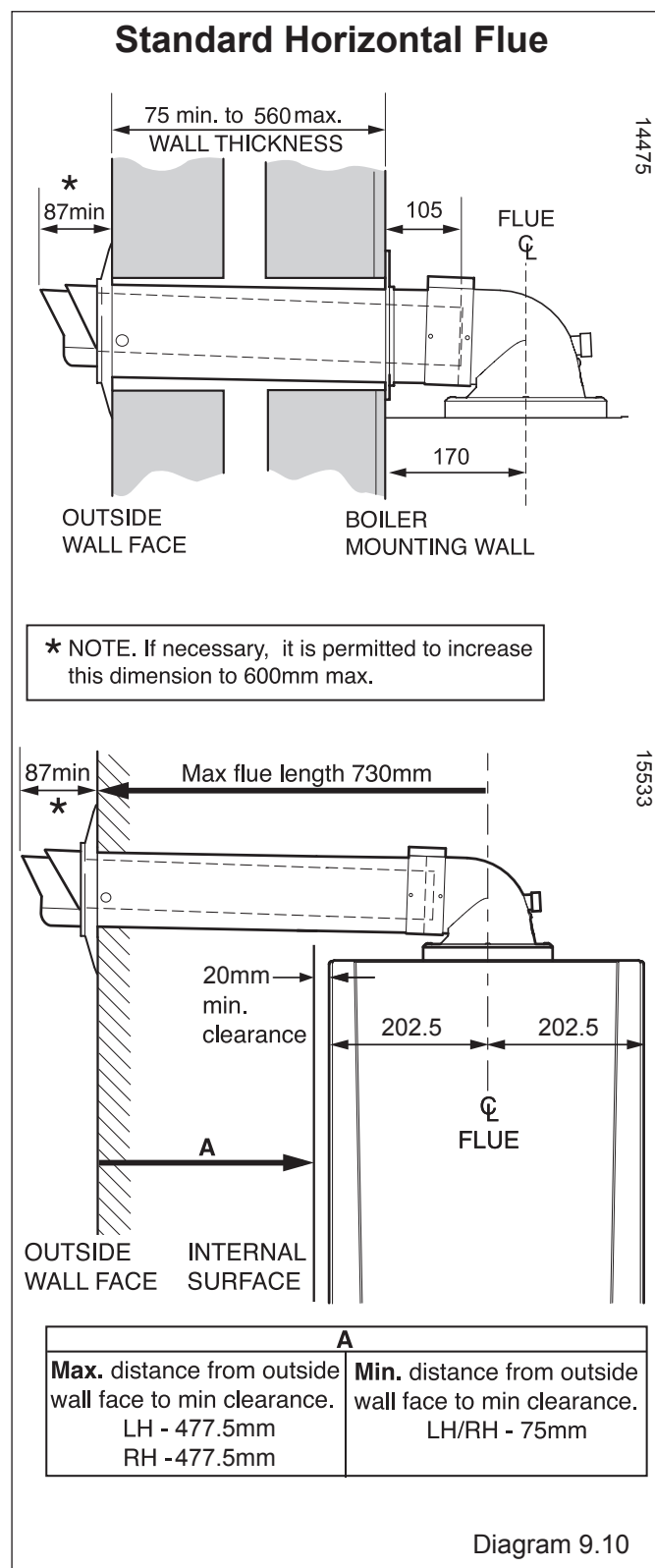

9 Standard Flue - Length, Preparation and Installation

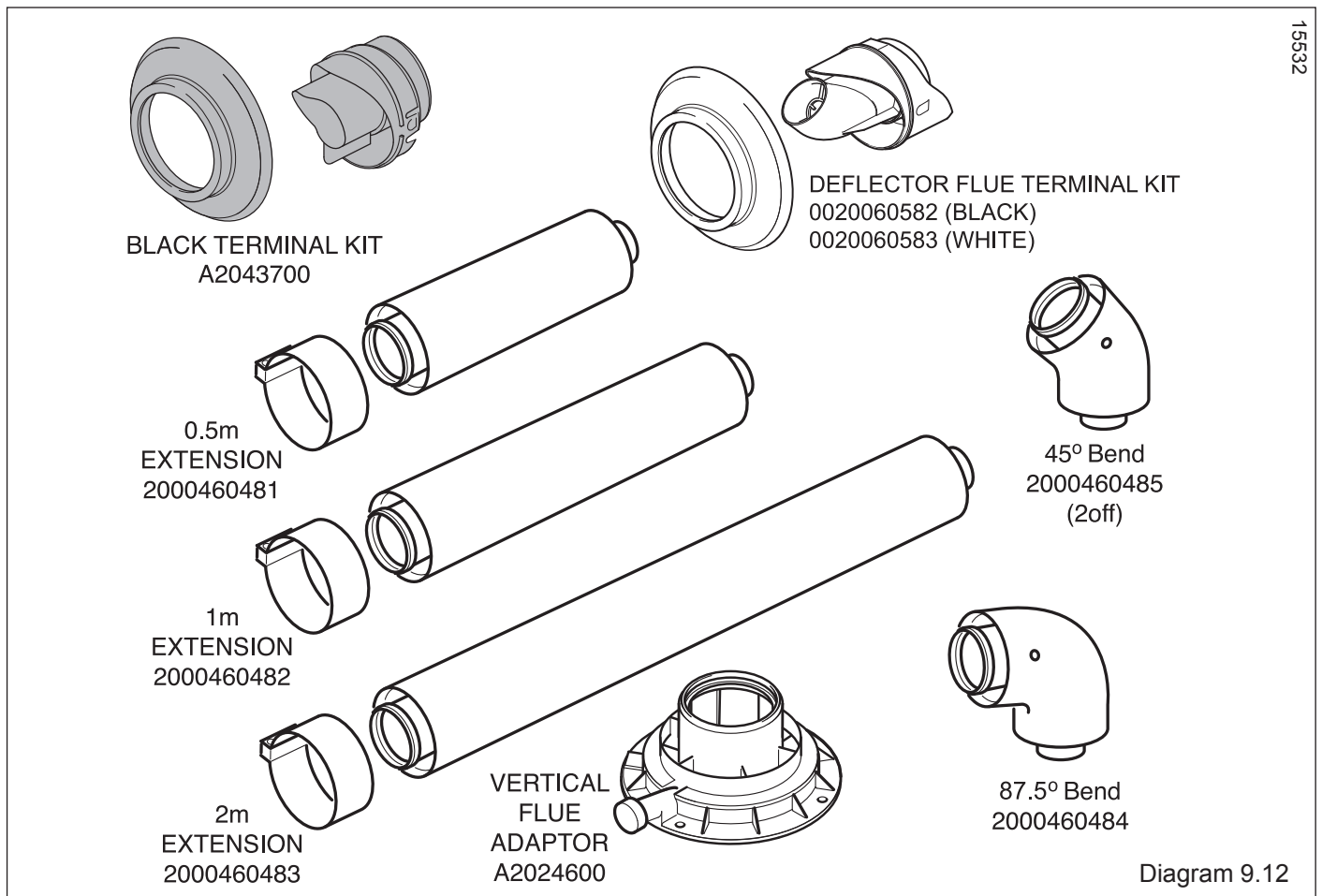
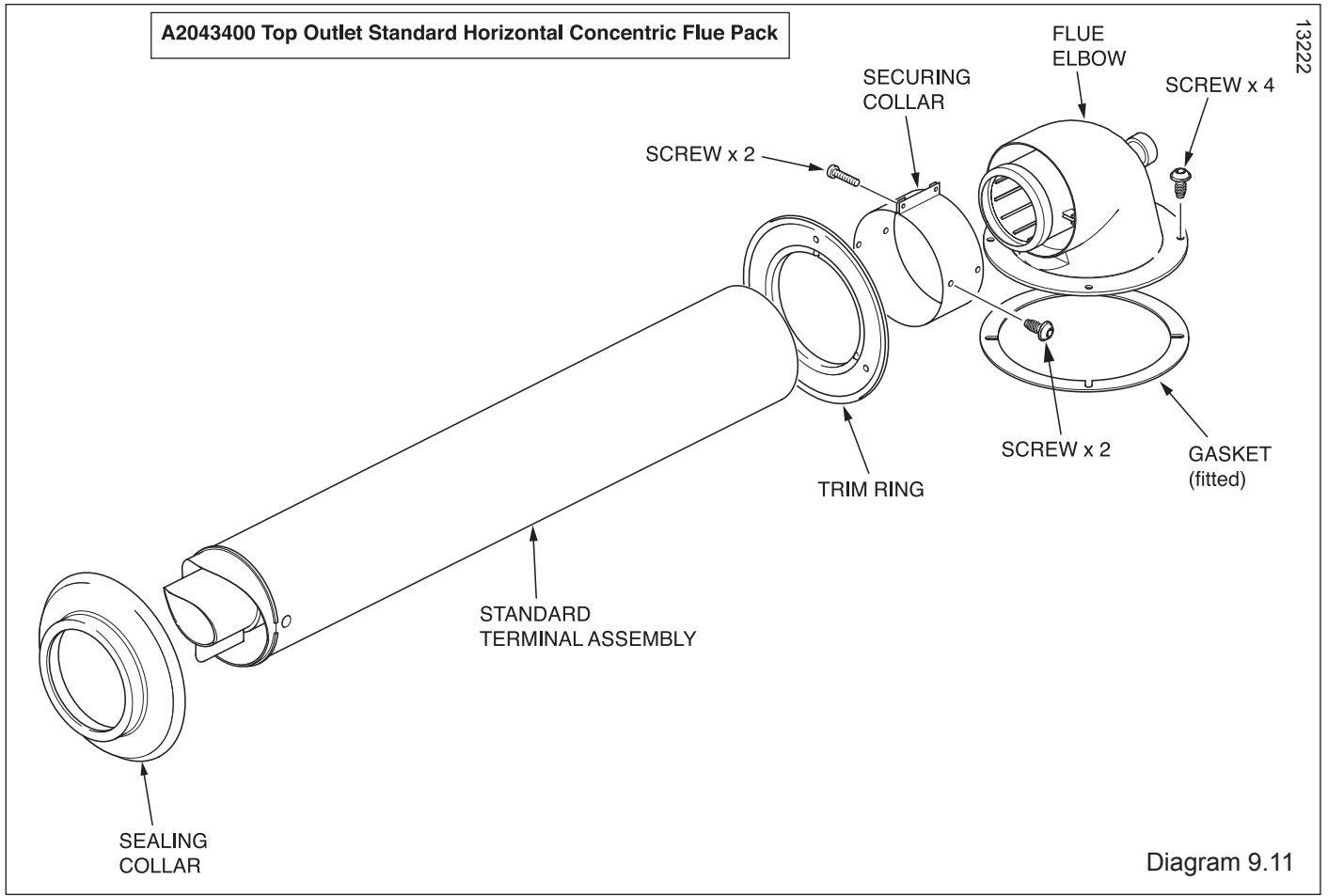

9 Standard Flue - Length, Preparation and Installation

9.7 Standard Horizontal Flue - A2043400

Refer to diagram 9.11 for kit contents.

9.8 REAR Flue

Temporarily secure the flue elbow, measure the distance from the outside wall to the butt joint, see diagram 9.13. If the measurement 'Y' exceeds 665mm, then the appropriate length of extension pipe is required. The minimum dimension is 180mm to suit a 75mm min wall thickness. The flue can project to a maximum of 600mm, refer to diagram 9.14.

9.9 SIDE Flue

Temporarily secure the flue elbow, measure the distance from the outside wall to the butt joint, see diagram 9.15. If the measurement 'Y' exceeds 665mm, then the appropriate length of extension pipe is required. The minimum dimension is 262.5 to suit a minimum wall thickness of 75mm. The flue can project to a maximum of 600mm, refer to diagram 9.14.

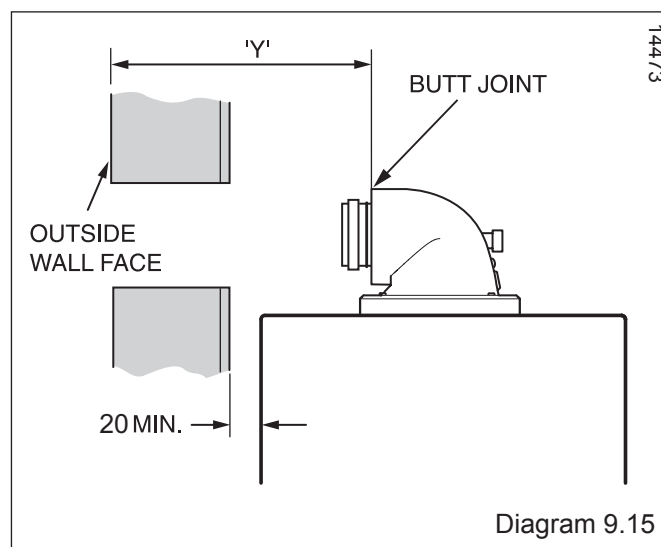
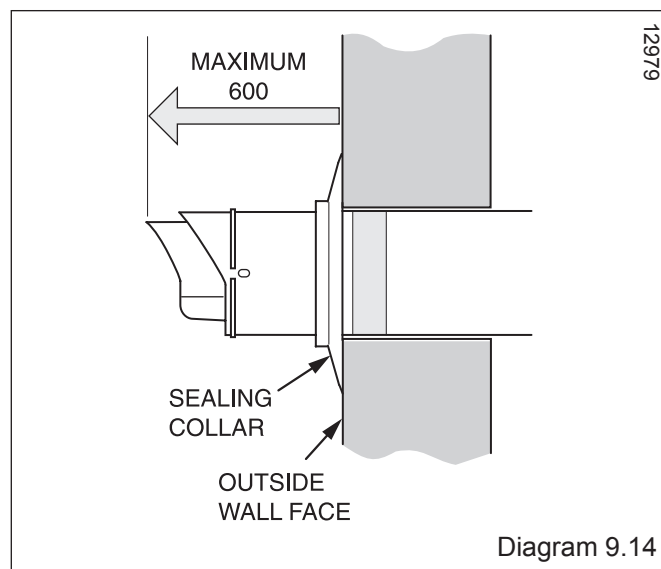
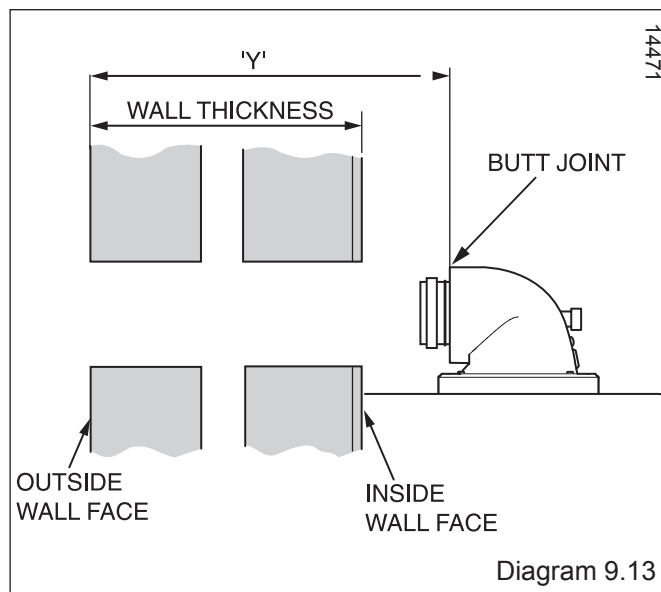

9 Standard Flue - Length, Preparation and Installation

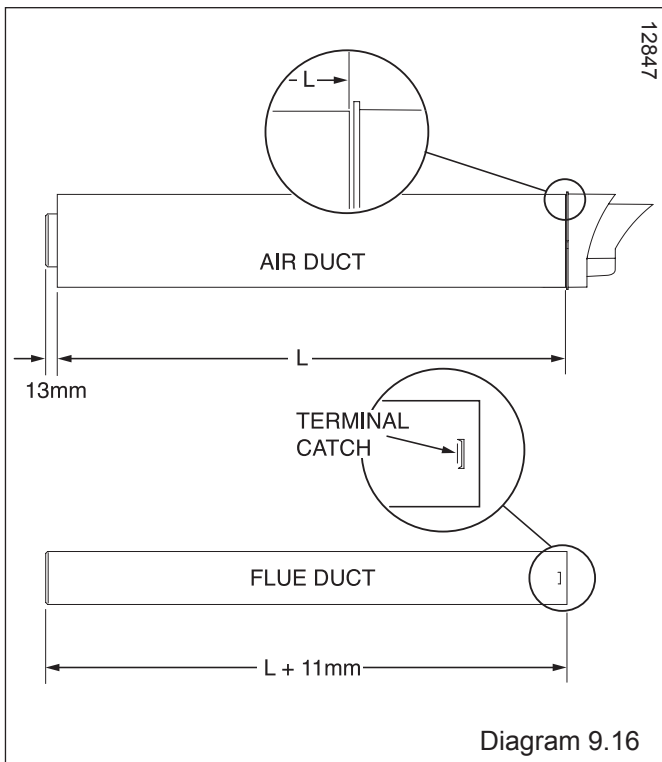

Diagram 9.16

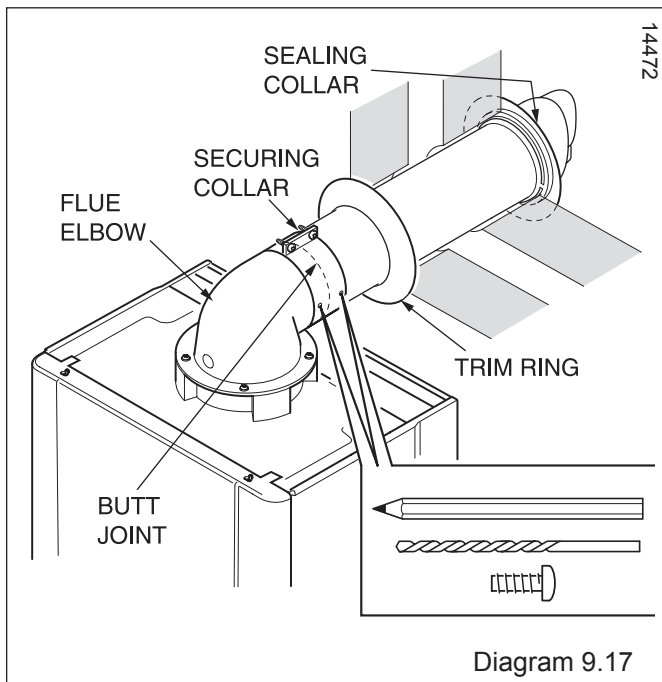

Diagram 9.17

9.10 Flue Fitting

Remove the flue elbow.

Separate the flue duct from the terminal by twisting to release the terminal catch, then pull out of the retaining seal, refer to diagram 9.16.

The flue duct cutting length ($L + 11\text{mm}$.) is shown in diagram 9.16.

The air duct should be cut at the opposite end to the terminal. The plastic flue duct **MUST** be cut at the opposite end to the terminal catch.

The plastic flue duct extensions **MUST** be cut at the opposite end to seal.

The cut ducts must be de-burred and all filings and debris removed.

Insert the flue duct into the air duct terminal assembly, remembering to engage the catch within the terminal.

NOTE: If the seals require lubricant to ease installation, do not use mineral oils or grease, only silicon grease or water is recommended.

Fit the sealing collar behind the locating lugs on the flue terminal, see diagram 9.17.

Push the flue assembly into the wall, externally or internally, initially until the end of the assembly protrudes a short way from the inside face of the wall. This will enable the internal trim ring (if required) to be positioned and allow the flue assembly to be drawn back into the flue elbow.

Secure the flue elbow in position on top of the boiler with four torque headed screws supplied.

Draw the flue assembly from wall and engage the flue duct into the elbow and butt fit between the air duct and flue elbow. Ensuring the correct alignment of the terminal.

Fit the securing collar into position, mark through two of the pre drilled holes in the securing collar. Remove securing collar and drill two 3mm diameter holes one in the elbow and one in the air duct, take care not to pierce the inner flue duct. Fit the securing collar and secure with screws provided, see diagram 9.17.

Slide the internal trim ring back against the wall, securing in place with a small amount of sealant if required.

NOTE: If the air and flue ducts have been correctly cut to the instructions the sealing collar should fit flush with the outside wall, check this.

9 Vertical Flue - Length, Preparation and Installation

9.11 Vertical flue

The vertical flue system is available as an option where the boiler position does not permit the use of the top horizontal flue system.

The system is made up from accessories. The accessories include terminal assembly, bends 45° and 90°, flue extensions, fixing bracket and appropriate weather collar, see diagram 9.19.

The maximum permitted straight flue length is 6,8 metres for Betacom 24C, 5,8 metres for Betacom 30C.

for each 90° or 2x45° bends fitted, the maximum length must be reduced by 1 metre, see diagram 9.18.

NOTE: 2x45° bends can replace 1x90° bend if necessary. When using 90° bends any horizontal extension pipe should be inclined by a minimum of 44mm/metre (2.5°) towards the boiler to facilitate condensate removal, see (a) in diagram 9.18. Alternatively use 45° bends to avoid horizontal runs, see (b) in diagram 9.18.

The terminal siting should be as shown in diagram 4.2. Measure the distance of flue length required for the installation.

The flue must be designed with a continuous fall towards the boiler.

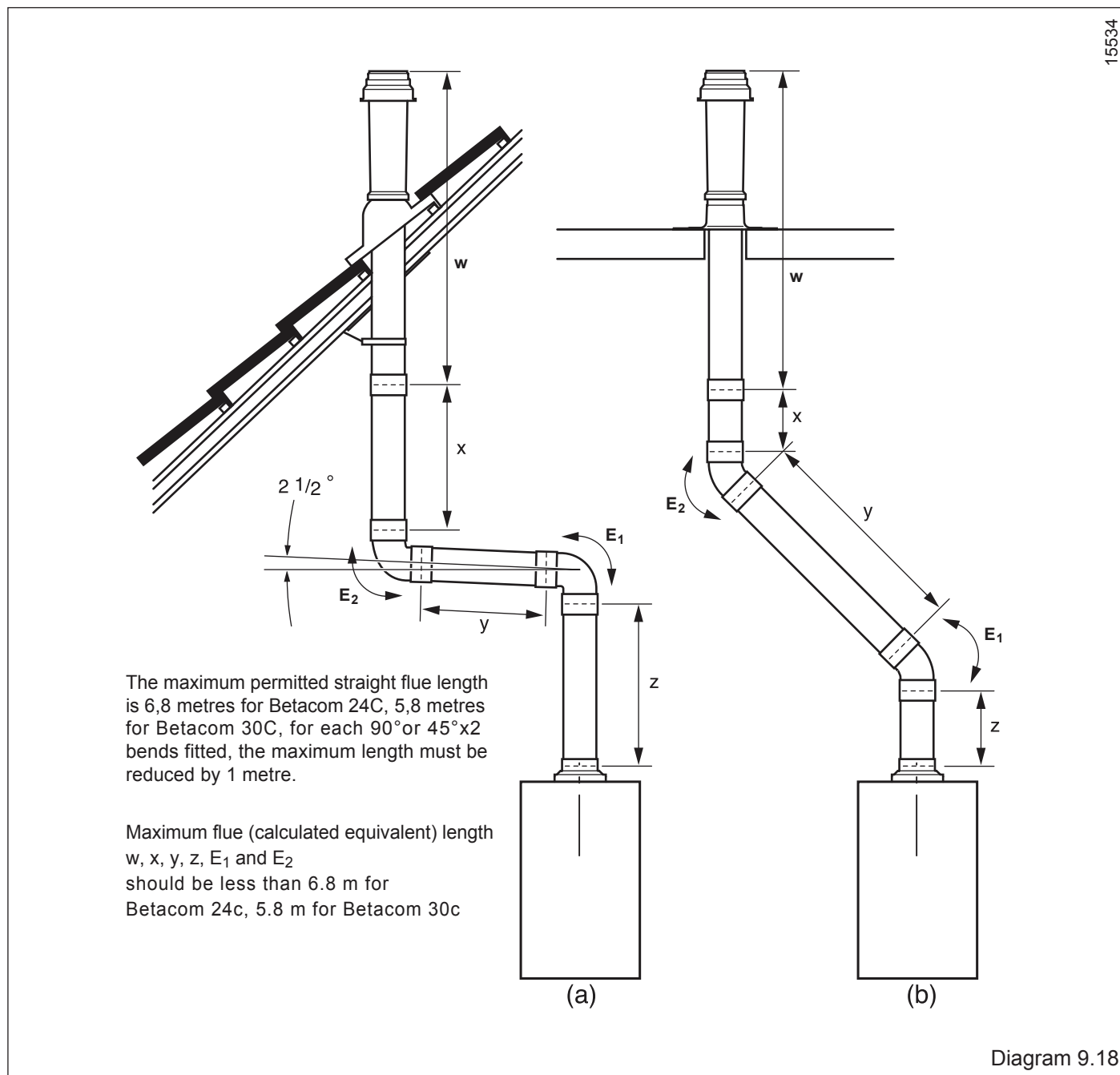

9 Vertical - Flue Length, Preparation and Installation

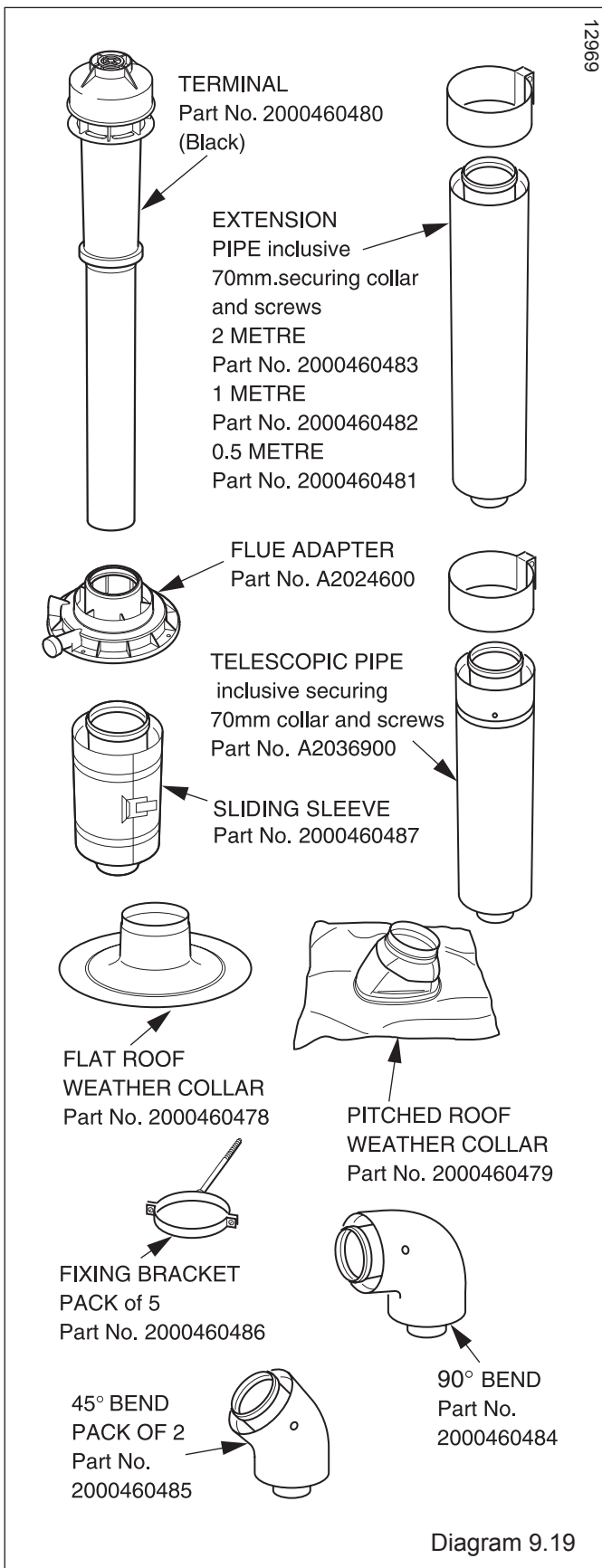

9.12 Flue Installation

Refer to diagram 9.20 and secure the flue adapter in position on top of the boiler with four screws supplied,

NOTE: The rubber 'O' rings of each section should be lubricated prior to assembly. Do not use mineral oils or grease, silicon grease or water is recommended.

Secure the first extension pipe to the flue adapter with the securing collar supplied by positioning the collar centrally over the joint, then tighten the two screws on the securing collar, see diagram 9.21.

Fit more extension pipes as required using the collar and screws supplied with each extension pipe. To fit position the collar centrally over the joint, tighten the two screws on the securing collar. Using the holes provided in the securing collar drill and insert the two self tapping screws supplied, see diagram 9.22.

The rubber 'O' rings of each section should be lubricated prior to assembly.

NOTE: Do not use mineral oils or grease, silicon grease or water is recommended.

When installing the flue it is recommended that it is supported every 2 metres and at every bend by a fixing bracket.

Project the rise of the flue pipe to roof level and cut a 150mm hole in the roof.

9.13 Flue Terminal Installation

(a) Pitched Roof

Fit the required pitched roof weather collar over the 150mm hole in the roof. Make good the tiling or slating around the collar incorporating the flashing of the weather collar. Position the angle cap over the weather collar in the correct orientation to attain the correct angle for your roof.

(b) Flat Roof

Fit the aluminium weather collar over the 150mm hole in the roof ensuring a weather tight seal.

From above carefully place the flue terminal through the weather collar.

9.14 Flue Terminal to Boiler Connection

Should the clearances above the boiler to roof not allow for extensions, it is permitted to cut the flue terminal ensuring the relationship of flue and air duct lengths are retained.

9 Vertical Flue - Length, Preparation and Installation

9.15 Completion of Installation

With the flue terminal positioned in the roof the length of the final pipe can be determined. If a telescopic length cannot be used, then a standard flue length can be cut to make the correct length. Cut the flue to the desired length measuring from the 'O' ring end and discard the plain end of the tube. The cuts must be square and made free of burrs to allow correct assembly.

NOTE: The flue pipe is 10mm longer than the air pipe, see diagram 9.23.

Carefully push the terminal assembly upwards to allow room for fitting the final flue piece. Fit a fixing bracket to the terminal assembly. Pull the terminal assembly down and join to the flue system. Ensure that the terminal is making a weather tight seal on the weather collar. Secure the fixing bracket fitted to the terminal to the roofing struts or a purpose made baton.

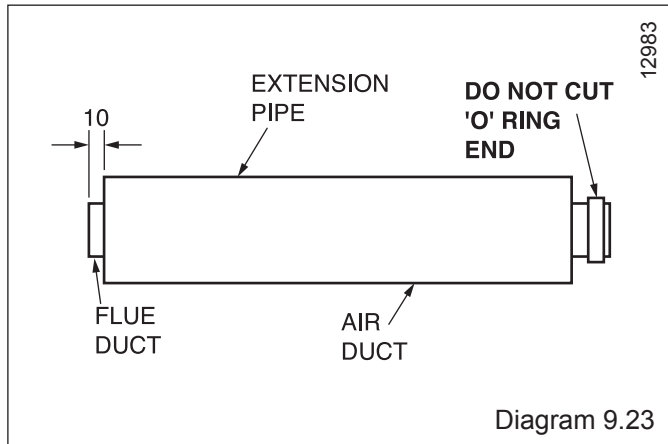
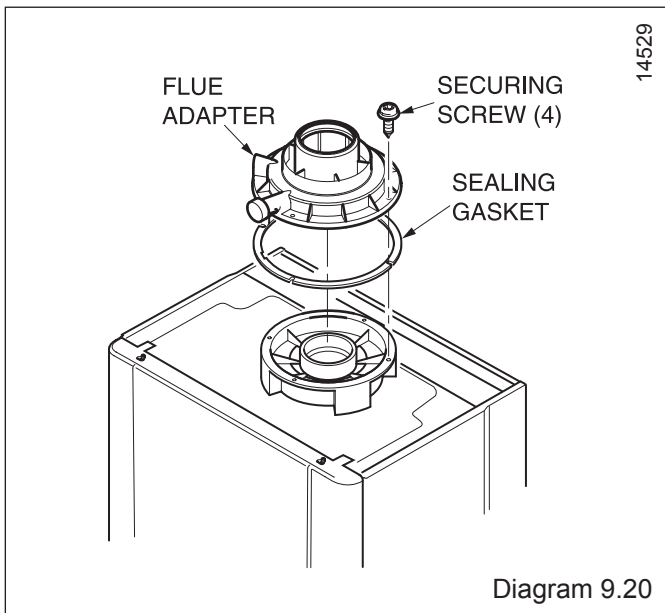
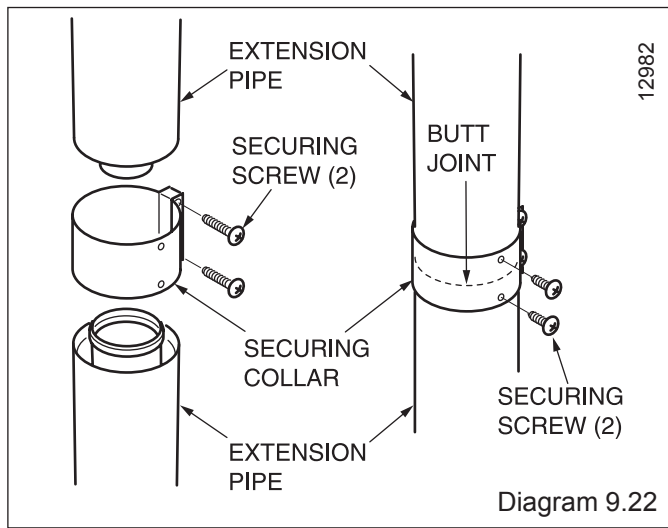
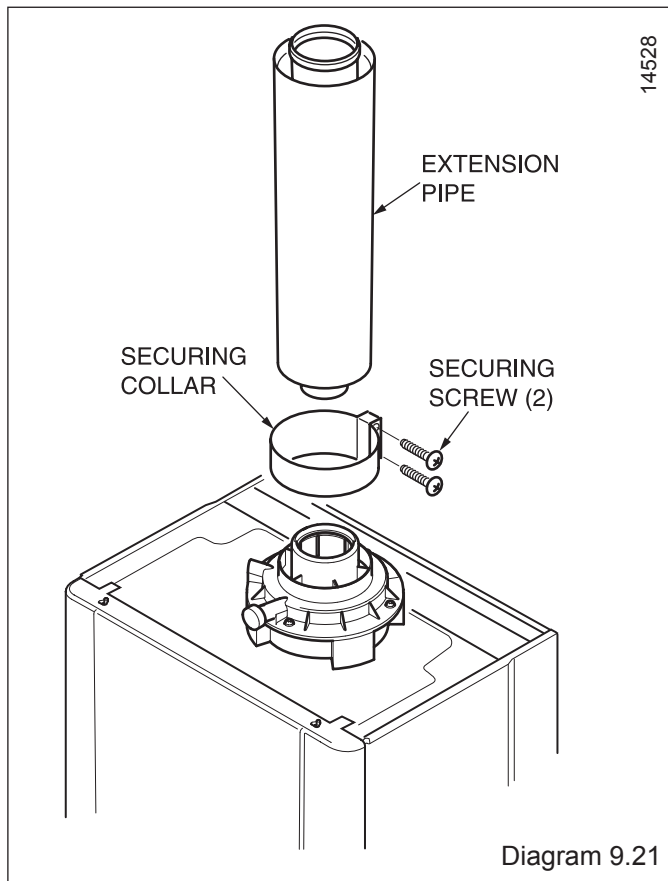

9 Twin Flue - Length, Preparation and Installation

14530

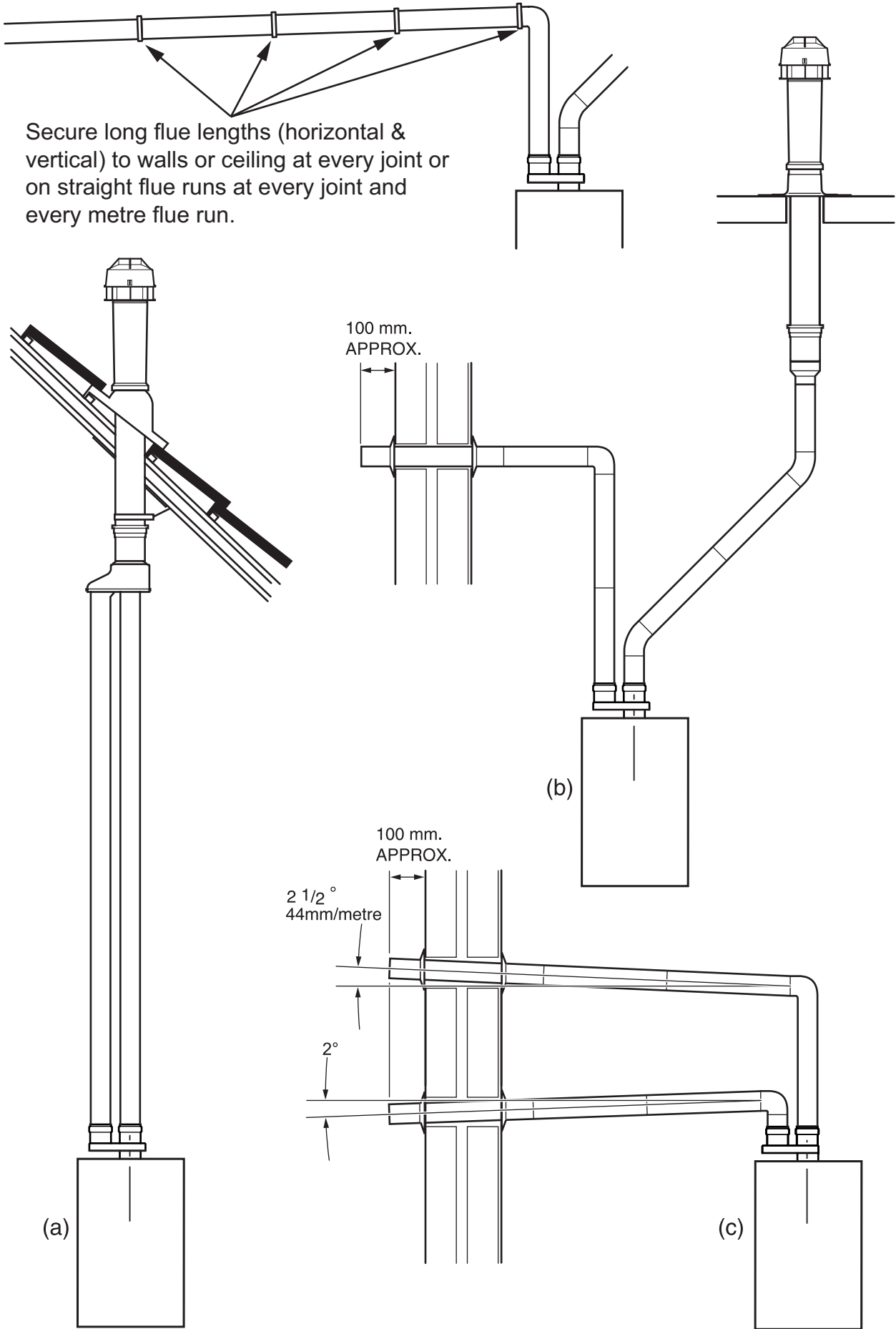
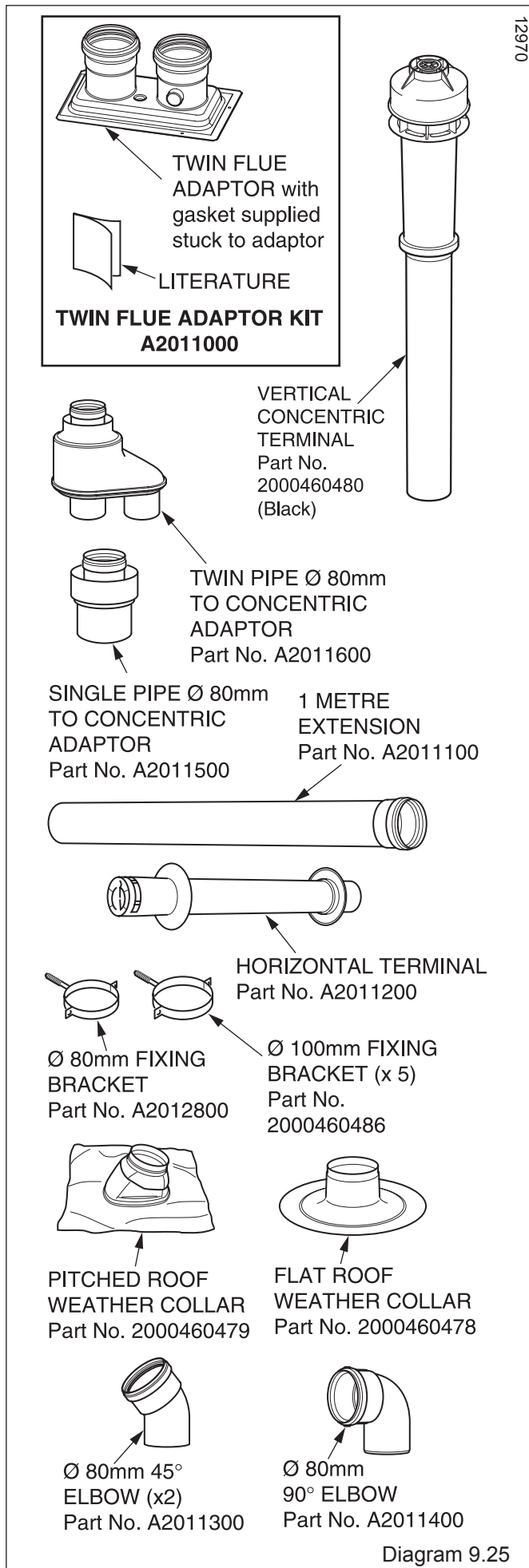

Diagram 9.24

9 Twin Flue - Length, Preparation and Installation



9.16 Twin flue

The twin flue system is available as an option when the top horizontal or vertical flue system is not appropriate. The system can provide an independent horizontal air inlet and flue outlet, horizontal air inlet and vertical flue outlet or vertical air inlet and flue outlet via a concentric terminal. The system is made up from accessories, see diagram 9.25.

NOTE: The air and flue outlets do not have to be equal lengths. 2x45° bends can replace 1x90° bend if necessary. The maximum permitted combined (air inlet + flue outlet) flue length is 14,3 metres for Betacom 24C, 11,9 metres for maximum flue length must be reduced by 1 metre, see diagram 9.24.

NOTE: When using 90° bends any horizontal run should be inclined by a minimum of 44mm/metre (2.5°) towards the boiler to facilitate condensate removal. Alternatively use 45° bends to avoid horizontal runs in the flue pipe.

9.17 Terminal Position

The clearances for a flue outlet are given in the "Flue Location and Ventilation" section. In addition the horizontal air inlet must not be closer than 300 mm from a flue outlet on the same wall or 1200mm from an opposing flue outlet.

9.18 Installation Details

The parts available for a twin flue system installation are shown in diagram 9.25.

9 Twin Flue - Length, Preparation and Installation

9.19 Boiler Connection

Place the twin flue adaptor onto the outlet of the boiler with the air inlet to the left hand side, see diagram 9.26. Secure the adaptor to the top panel with the screws provided. Care should be taken when inserting the screw through the hole in adaptor top.

To facilitate engagement, it is recommended that the rubber 'O' rings are lubricated with silicone grease or water prior to assembly.

9.20 Air and Flue Pipe Installation

The air and flue pipes can now be built up from the boiler. The flue must be designed with a continuous fall towards the boiler. If using the horizontal flue pipe or 90° bends the pipe must be inclined at 44mm/metre (2.5°) minimum, see diagram 9.24.

Alternatively if space allows, use 45° bends in place of 90° bends.

The rubber 'O' rings of each section should be lubricated prior to assembly with silicone grease.

When building the flue up it is recommended that it is supported every 2 metres and at every bend by a fixing bracket.

9.21 Horizontal Terminal Installation

With due consideration to terminal clearances mentioned in section 4.2 drill the one or two holes as required with a 90mm core drill.

Push the horizontal terminal through the wall allowing approx. 100mm to protrude outside.

Push a grey rubber wall seal onto either side of the wall ensuring that both wall seals are pushed up to the wall surface, see examples (b) and (c) diagram 9.24.

9.22 Vertical Terminal Installation

With due consideration to terminal clearances mentioned in Section 4.2, project the rise of the flue pipe to roof level and cut 150mm hole in the roof.

(a) Pitched Roof

Fit the required pitched roof weather collar over the 150mm hole in the roof. Make good the tiling or slating around the collar incorporating the flashing of the weather collar. Position the angle cap over the weather collar in the correct orientation to attain the correct angle for your roof. One way round gives a pitch of 25°-38° and the other gives 37°- 50°.

(b) Flat Roof

Fit the aluminium weather collar over the 150mm hole in the roof ensuring a weather tight seal.

9.23 Horizontal Pipes-Completion of Installation

Having built the pipe(s) from the boiler to the terminal(s), the length of the final pipe piece can be determined. Cut pipes at the opposite end to the 'O' ring seal making square and free from burrs. Push the horizontal terminal through the wall to engage the final pipe piece and pull back ensuring the grey wall seals are fully pulled up to the outside and inside wall faces.

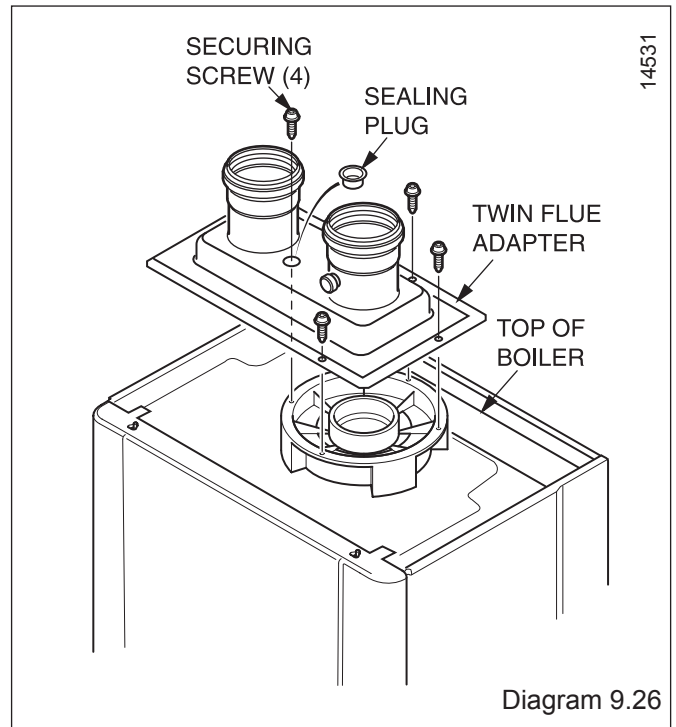

9.24 Vertical Pipes-Completion of Installation

Refer to diagram 9.24.

For installation of (a), attach the twin pipe to concentric flue adaptor, part number A2011600, to the base of vertical terminal assembly. For installation of (b), attach the single pipe to concentric adaptor, part number A2011500, to the base of vertical terminal assembly.

With the vertical terminal assembly positioned in the roof, the length of the final pipe can be determined. Cut the flue to the desired length measuring from the 'O' ring seal end and discard the plain end of the tube. The cut end should be square and free from burrs. Carefully push the terminal assembly upwards to allow room for fitting the final flue piece(s). Fit a 100mm fixing bracket to the terminal assembly Part No2000460486. Pull the terminal assembly down and join to the flue system. Ensure that the terminal is making a weather tight seal on the weather collar. Secure the fixing bracket fitted to the terminal to the roofing struts or a purpose made baton.

9 Plume Management Kit

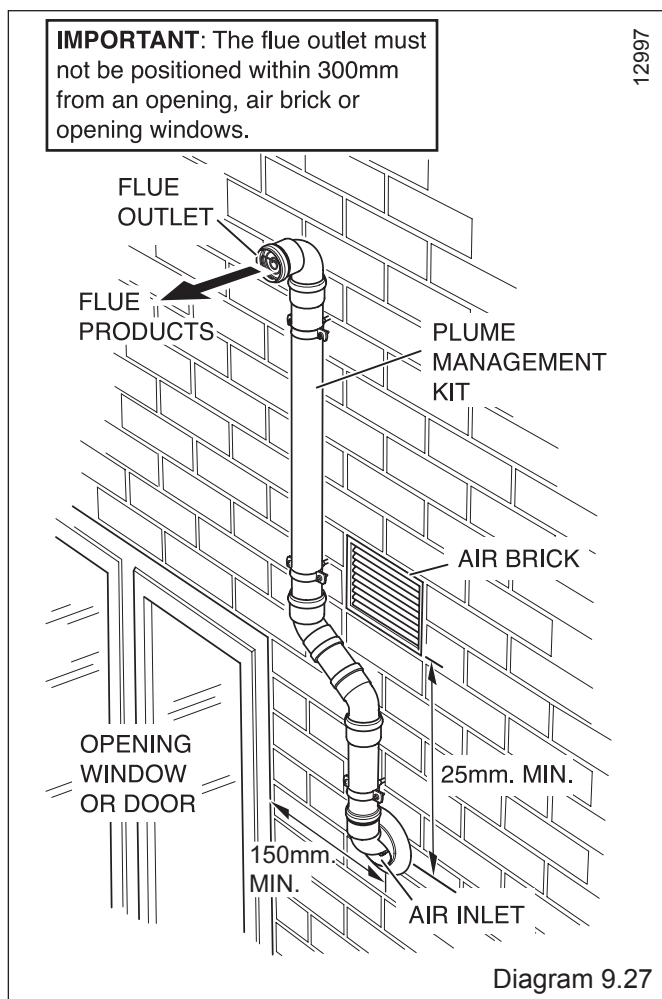

9.25 Plume Management Kit

The Plume Management Kit: Part No. A2044100 (white) or A2044000 (black) can be used to overcome many site issues. The Plume Management Kit will fit to the Top Horizontal Telescopic, Rear Horizontal Telescopic and Standard Horizontal Flue. This enables the flue products to exhaust further away from the boiler, thereby reducing the impact of pluming.

NOTE: The flue air inlet can be sited closer to doors, opening windows and air bricks, than stated in section 4.2, see diagram 9.27.

The maximum length of the Plume Management Kit must NOT exceed 2m with a horizontal concentric flue length of 1m max. For each 90° bend or 2 x 45° bends the maximum length of the Plume Management Kit must be reduced by 1m.

For more information contact Glow-worm, refer to page 2. The Plume Management Kit is supplied with installation instructions.

Refer to BS5546 or BS6798 for advice on disposal of boiler condensate.

10 Electrical Connection

WARNING: This appliance must be earthed.

- This appliance must be wired in accordance with these instructions. Any fault arising from incorrect wiring cannot be put right under the terms of the Glow-worm guarantee.
- All system components must be of an approved type. Electrical components have been tested to meet the equivalent requirements of the BEAB.
- Do not interrupt the mains supply with a time switch or programmer.
- Connection of the whole electrical system and any heating system controls to the electrical supply must be through a common isolator.
- Isolation should preferably be by a double pole switched fused spur box having a minimum contact separation of 3mm on each pole. The fused spur box should be readily accessible and preferably adjacent to the boiler. It should be identified as to its use.
- A fused three pin plug and shuttered socket outlet may be used instead of a fused spur box provided that it is not used in a room containing a fixed bath or shower.
- The boiler is suitable for installation in bathroom zones 2 and 3.

10.1 Electrical Wiring

The boiler is supplied factory wired complete with 1.5 m of mains lead. All electrical connections to the mains supply must be made in full accordance with the current I.E.E. regulations. The boiler must be connected to an effective earth system. A 3 amp fused three pin plug and shuttered socket outlet may be used instead of a fused spur box provided that it is not used in a room containing a fixed bath or shower.

10 Electrical Connection

10.2 System Controls 24V

WARNING: UNDER NO CIRCUMSTANCES MUST ANY MAINS VOLTAGE BE APPLIED TO ANY OF THE TERMINALS ON THE 24V CONNECTION.

The 24V low voltage room thermostat terminal block is located on the left side of the rear cover of the controls box. To access the 24V low voltage room thermostat terminal block remove the front panel secured with two screws, lift off the two retaining lugs, see diagram 10.1. Carefully pull forward and down the controls fascia, see diagram 10.2.

On connection of a voltage free room thermostat to the boiler, the factory fitted bridge across the room thermostat terminal block must be removed, see diagram 10.3.

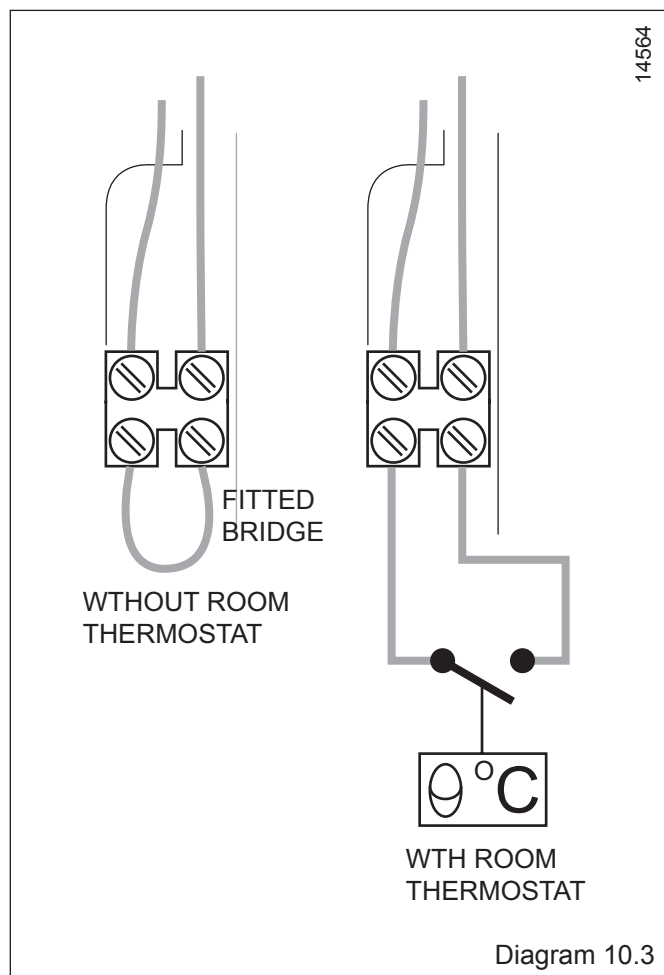
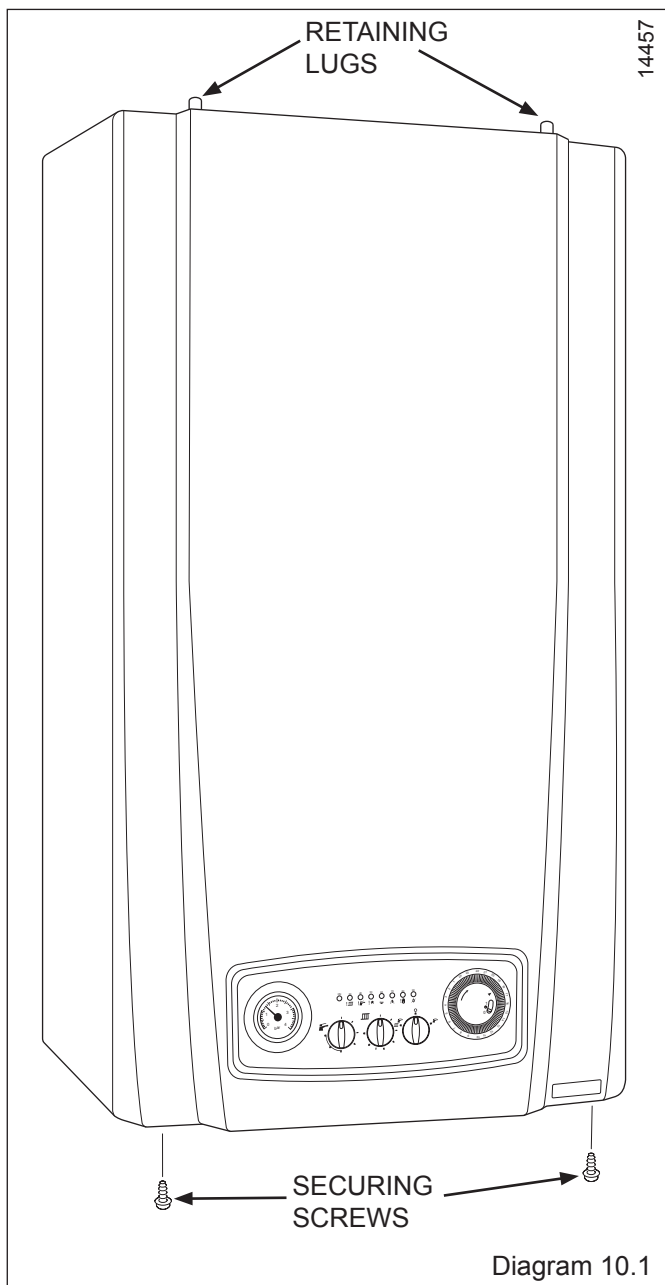
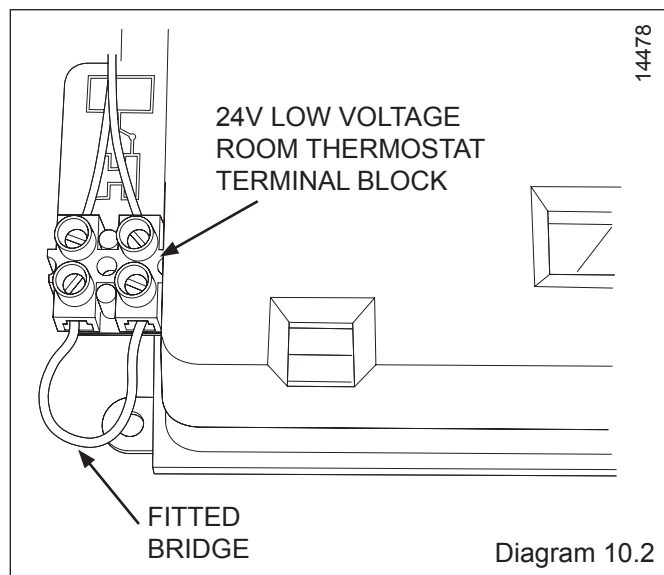

10 Electrical Connection

10.3 System Controls 230V

If a mains voltage thermostat is to be used. Unclip the two front retaining clips on the controls fascia, see diagram 10.3. Unclip and carefully pull down the control circuit board cover, see diagram 10.4. to access the mains voltage connection located on the printed circuit board, see diagram 10.5. On connection of a mains voltage room thermostat to the boiler, the bridge wire on factory fitted plug must be cut to fit a connector block.

NOTE: Mains powered thermostats must be connected directly to the mains circuit board as indicated in diagram 10.6.

NOTE: Ensure that the polarity of the mains connection is correct as reversed polarity may cause the appliance to malfunction.

NOTE: While the boiler's main pcb, pump, three-way valve and gas valve are supplied at 230V AC., all other components and associated circuits are supplied at low voltage.

NOTE: When re-assembling, take care NOT TO TRAP the cables and wires.

NOTE: Connection to the mains electrical supply must be maintained at all times in order to provide domestic hot water, frost protection and pump over-run facility. Ensure that the boilers electrical supply is not interrupted by any external controls.

10.4 Electrical Connections - Testing

Carry out preliminary electrical system checks prior to making the final connection as below:

1. Test insulation resistance to earth of mains cables.
2. Test the earth continuity and short circuit of cables.
3. Test the polarity of the mains.

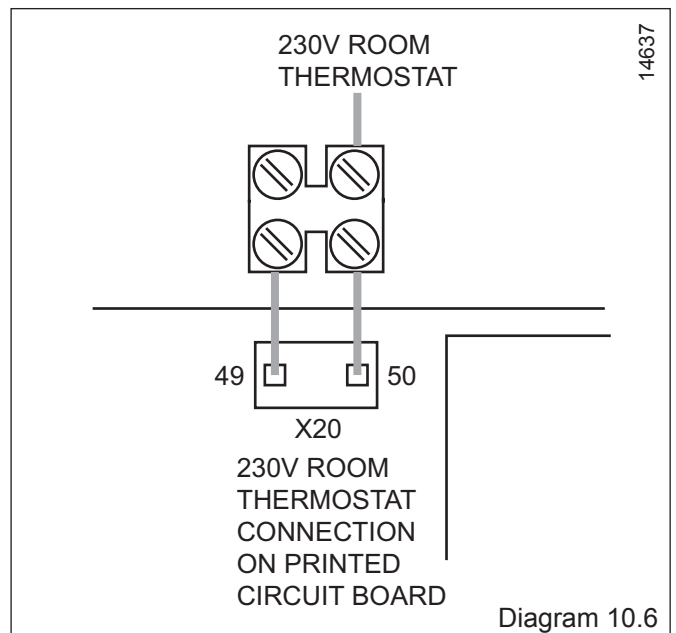
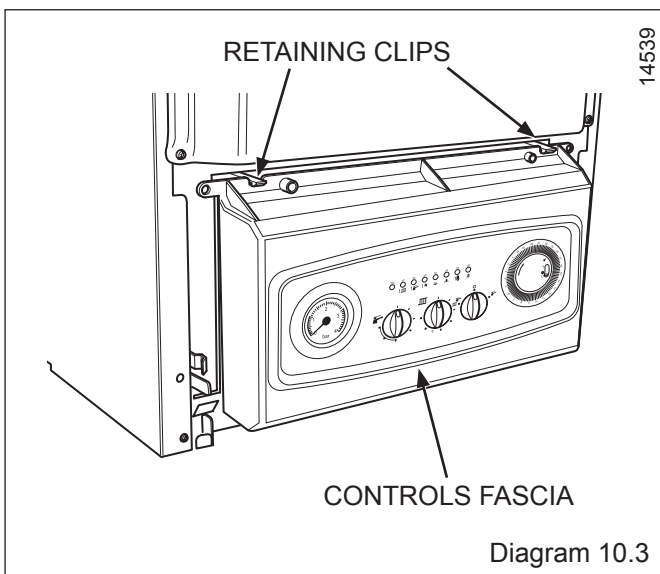
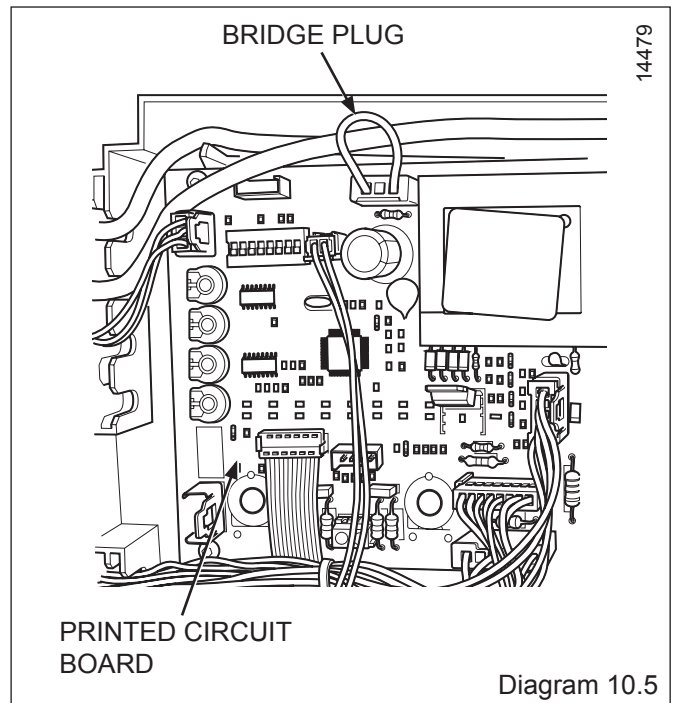
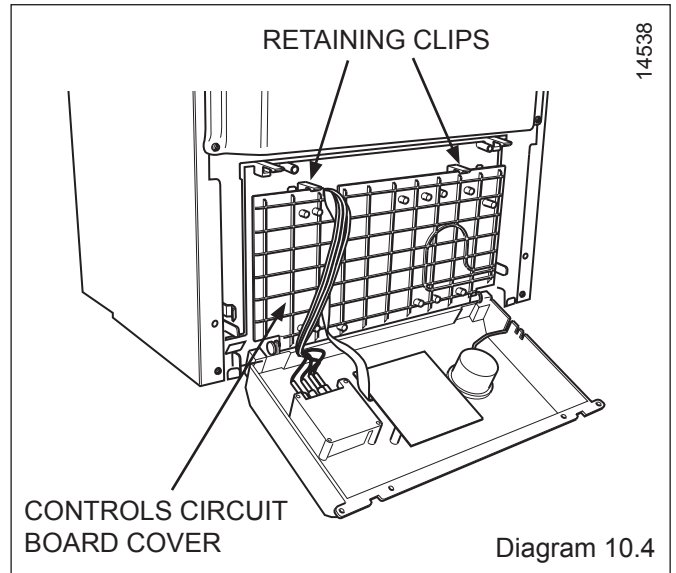

11 Commissioning

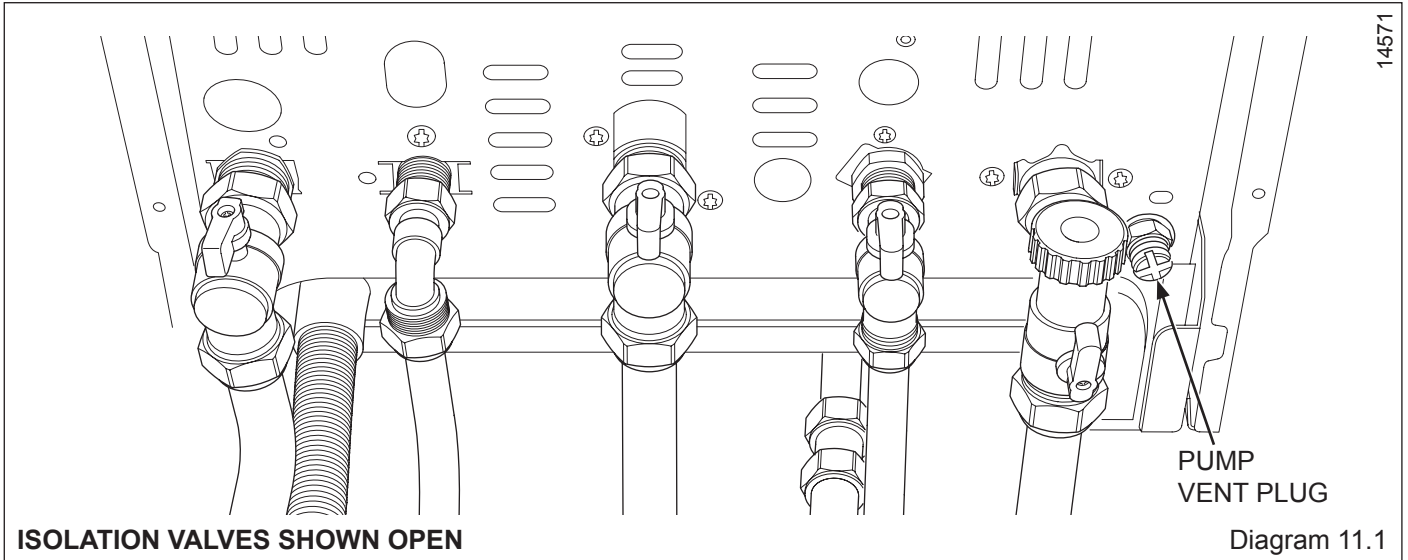

IMPORTANT: At the time of commissioning, complete all relevant sections of the Benchmark Checklist located in the centre pages of this document.

IMPORTANT NOTE: In order to maintain the appliances warranty; after initial filling the heating system must be thoroughly flushed using a propriety cleanser to remove foreign material and contaminants.

11.1 Preliminaries - All Systems

Do Not operate the boiler without water.

The commissioning should be carried out by a **competent person** approved at the time by the Health and Safety Executive and in accordance with the current issue of BS6798.

Make sure that the system has been thoroughly flushed out with cold water and that all cleanser if used has been removed.

With the gas service isolation valve closed, with no demand from any external controls and the power supply to the boiler switched off, test for gas soundness and purge air from the gas supply.

11.2 Filling the System

On completion of the boiler installation and ensuring that all water connections are correctly made the boiler may be filled with water via the filling loop (not supplied with the boiler).

1. Ensure that two manual feed valves and boiler isolation valves are open, see diagram 11.1.
2. Release the cover cap of the boilers automatic air vent situated on top of the pump, see diagram 11.2.
The manual feed valves must be closed and the filling loop disconnected once the pressure sensor, sited on the boilers control panel, indicates a system pressure between 1.0 and 1.5 bar, see diagram 11.3.
3. Check that all the water connections throughout the system are sound and bleed each of the heating systems radiators in turn. As air is vented the system pressure may need topping back up to 1.0bar.
Air must be vented from the boiler's pump by unscrewing the pumps integral vent plug and allowing water to bleed for a few seconds. Take care not to allow water to splash onto any electrical components.
4. When the system is bled of any air it must be filled until the pressure display indicates a system pressure of 1.5 bar.
5. If the pressure exceeds 1.5 bar discharge the excess pressure from the system via a radiator valve or pipe connection. Do not use the safety discharge valve as the valve seat may become contaminated with debris and fail to re-seal.

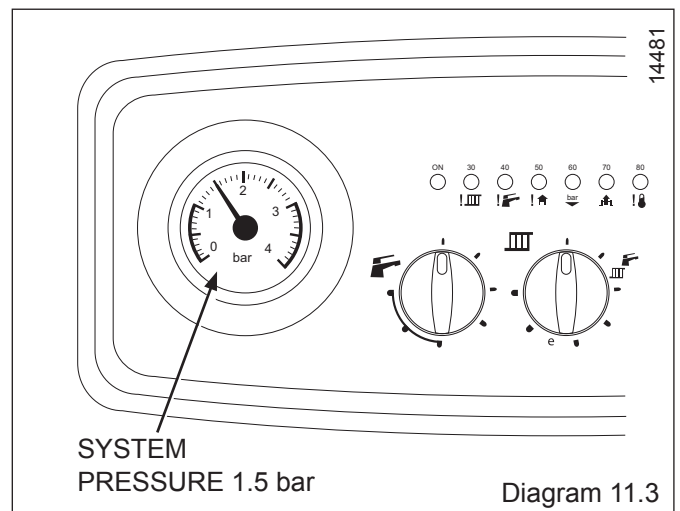
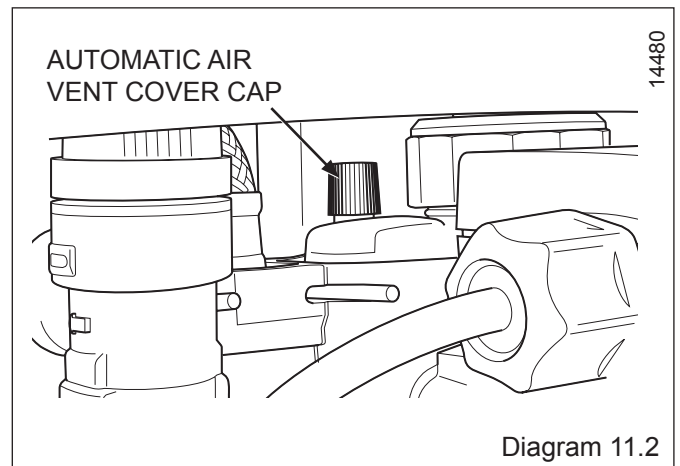

11 Commissioning

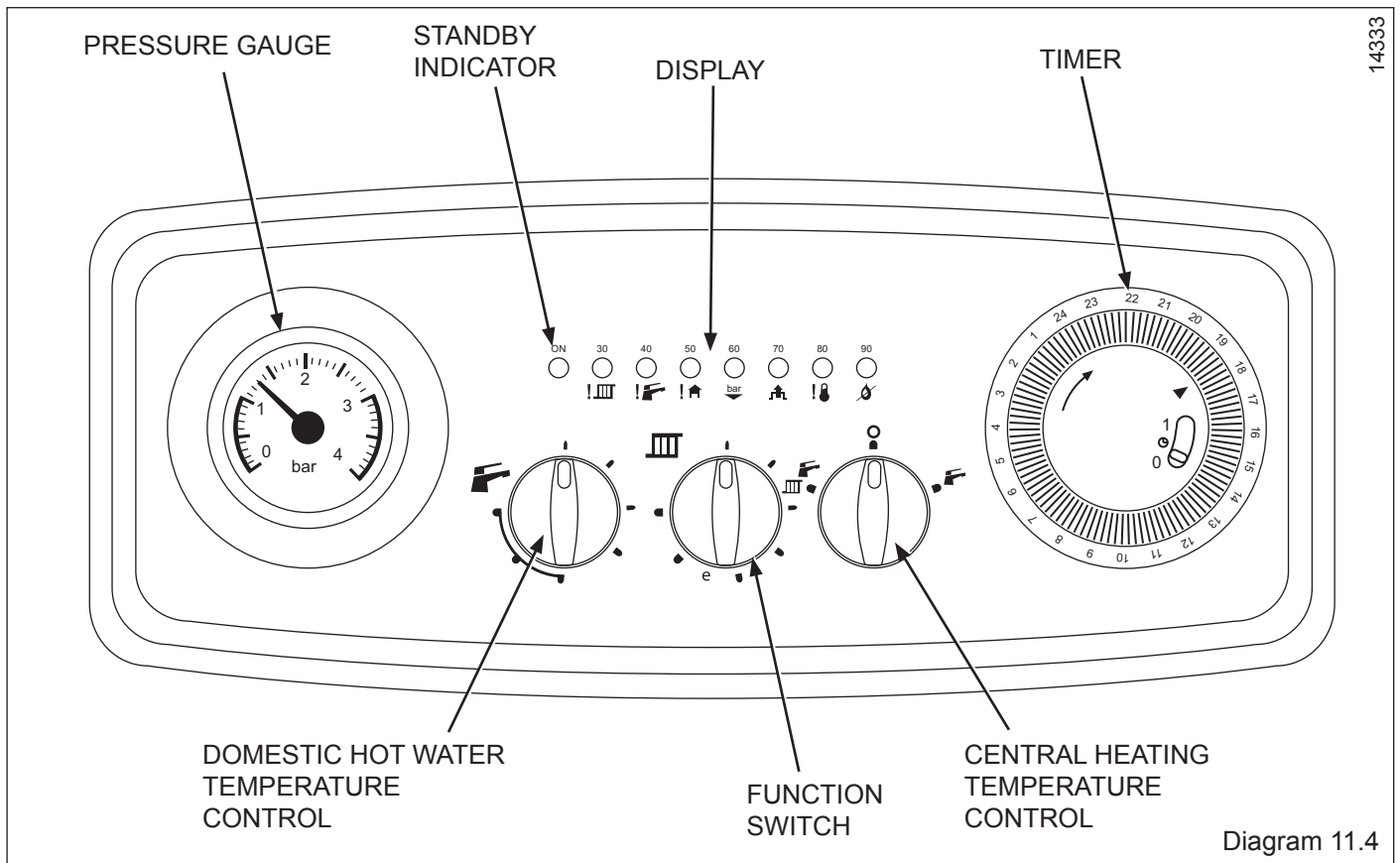

11.3 Control Panel Functions, diagram 11.4.

Central heating and domestic hot water temperature controls: The boiler's integral control unit monitors and adjusts both the boiler's hydraulic circuit and D.H.W. water outlet temperatures by means of sensors located on the CH heating and D.H.W. flow outlets. The sensors electrical resistance, which is dependant on temperature, determines the current passing through the control potentiometers located on the control panel. The respective potentiometer control dial allows manual setting of the maximum required temperature (reference value) being between 30° and 85°C for CH heating and 35° and 64°C for D.H.W. When the boiler operates in heating or D.H.W. mode, the current received is compared to the manually set reference value. The difference of the two values operates the modulation of the gas valve adjusting the useful heat output generated and stabilising the temperature to within $\pm 1^\circ\text{C}$.

Re-set function: Should the boiler lock out at any time, please check the gas supply and ionisation probe position, the boiler may be re-started by switching to standby "O" position waiting 15-30 seconds.

Switching back to its previous position once the fault has been eliminated.

Function switch: The three position switch allows the boilers operation to be set to 'Stand-by' (centre position), 'Heating + D.H.W.' (left hand position) or 'D.H.W. only' (right hand position).

11.3 Commissioning

The Betacom 24c and 30c boilers have been tested and pre-set at the factory and is dispatched with its on board controls set to provide a maximum central heating and D.H.W. output. Consequently, once all the connections have been made and the boiler has been filled with water to the designed system operating pressure, the boiler may be fired prior to adjusting it's on board parameters to match the heating systems requirements.

11.4 Initial Lighting

Prior to firing: Check that the electrical supply to the boiler is 'On' (The green boiler 'Stand by' indicator will light) and the gas service isolation valve is in the open position, see diagram 11.1.

Set the boiler's central heating and domestic hot water temperature controls to maximum by turning them fully clockwise.

Set the external room thermostat (if fitted) to maximum and open the thermostatic radiator valves to maximum. Switch the boilers function switch to the central heating and domestic hot water position. The boiler's control unit will now automatically carry out pre-ignition safety checks before igniting the burner.

11 Commissioning

11.5 Setting Operational Pressure

Minimum setting

Remove the sensing tube from the gas valve.

Remove one lead from the modulating gas valve coil, see diagram 11.6.

Refer to diagram 11.7.

Connect a suitable pressure gauge the pressure outlet of the gas valve.

Turn the boiler's function switch to the 'Winter' position. (Heating and Hot Water), see diagram 11.4

Turn the central heating temperature control to maximum setting.

Remove the protective cover from the gas valve adjuster. Turn the inner screw using a screwdriver, clockwise: to increase the pressure setting, anticlockwise: to decrease the pressure setting.

After correct adjustment see, 'Boiler specification section' page 8, re-connect the electrical connector and protective cover and replace the sensing tube to the boiler.

Maximum setting

Remove the sensing tube from the gas valve, see diagram 11.5.

Remove the protective cover from the gas valve adjuster. Push the ball inside the modulating gas valve coil using a sharp pointed tool.

Turn the nut with a 10mm spanner (keeping the ball in without any rotation) clockwise: to increase the pressure setting, anticlockwise: to decrease the pressure setting.

After correct adjustment see, 'Boiler specification section' page 8.

Finally, replace the sensing tube to the gas valve.

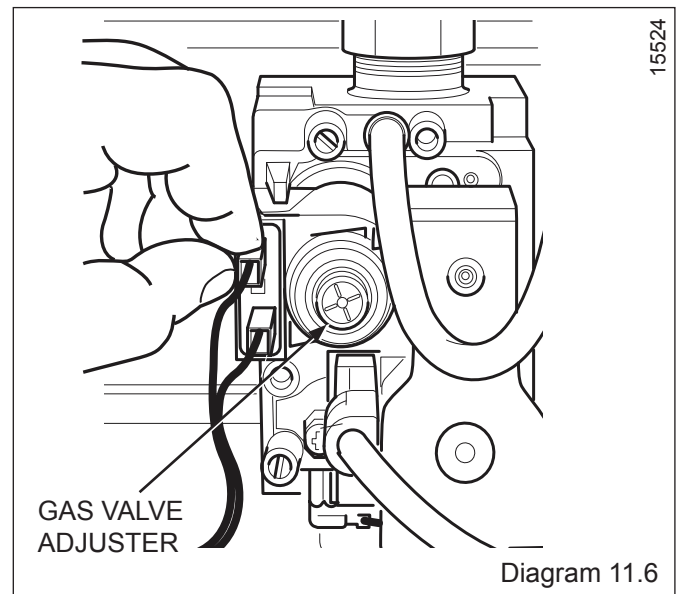
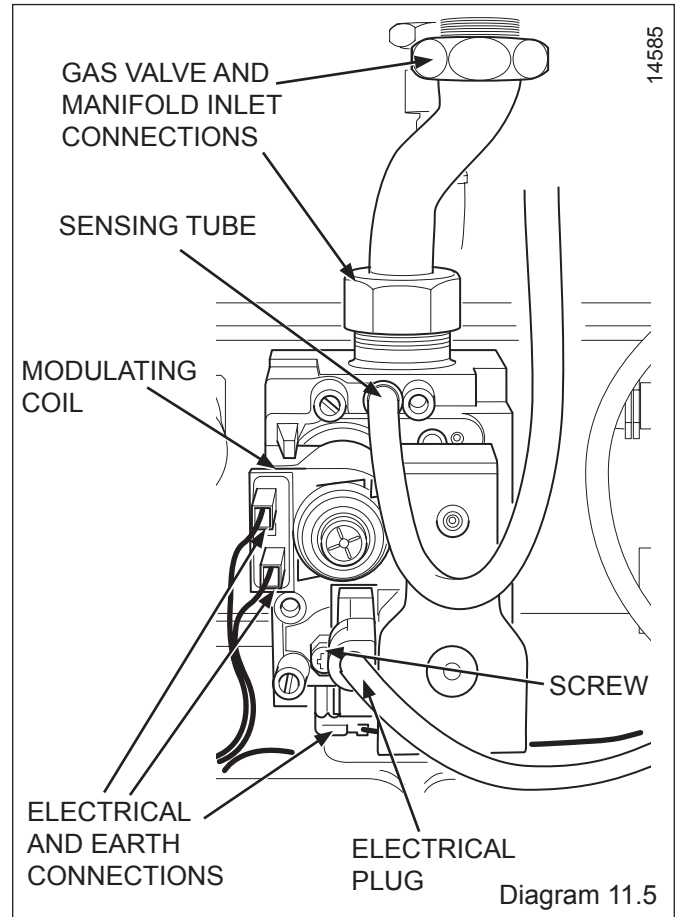

11 Commissioning

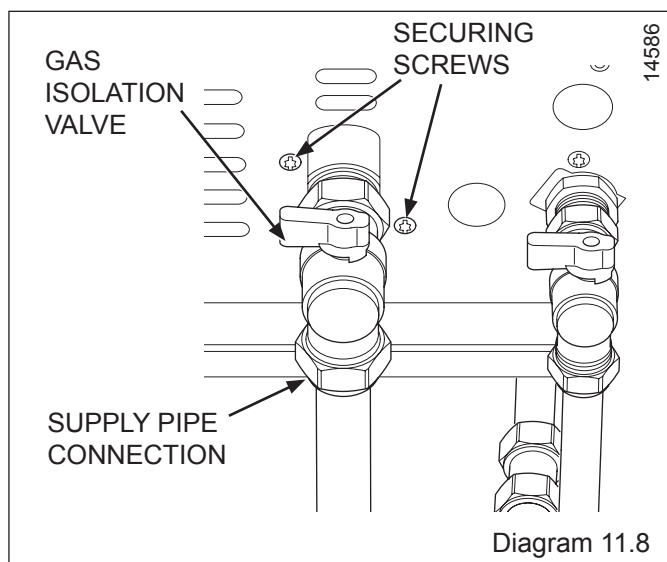
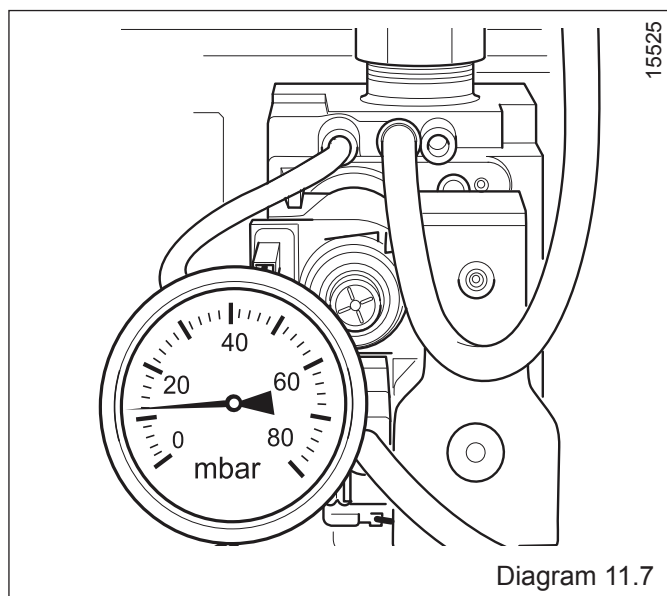

11.6 Checking the gas rate

The boiler is fitted with a fully modulating automatic gas valve. With all other gas appliances turned off measure the gas rate at the gas meter. Check that the gas rate is as stated in the table below:

Appliance	Maximum net heat input in kW	Gas rate
		Natural gas in (m ³ / h) nominal
Betacom 24c	25,7	2,72
Betacom 30c	28,5	3,02

Checking the combustion products

While adjusting the burner pressure at maximum and minimum, combustion products can be checked according to the table below:

Appliance	Combustion Products					
	CO ₂ (Vol - %)				CO (ppm)	
	Natural gas tolerance		Propane tolerance		Natural gas tolerance	Propane tolerance
	Max	Min	Max	Min		
Betacom 24c	8.60 ± 0.5	3.85 ± 0.5	9.60 ± 0.5	4.40 ± 0.5	< 400	< 400
Betacom 30c	8.10 ± 0.5	2.90 ± 0.5	9.30 ± 0.5	3.35 ± 0.5	< 400	< 400

11 Commissioning

11.7 Boiler Adjustments

The boiler incorporates 4 potentiometers and a bank of dip switches to allow adjustment to its pre-set parameters. These are situated on the rear of the control panel.

The potentiometers can easily be accessed by removing the cover on the rear of control panel. However, to reach the dip switches, the control panel must be opened, see diagram 10.4.

Setting the maximum CH heating flow temperature: The boiler is dispatched with a maximum flow temperature factory set to 85°C. Where a lower maximum temperature is required such as in the case of under-floor heating, the factory setting can be altered between a maximum of 50°C and a minimum of 30°C, by fitting dip switch '6' into "ON" position, see diagram 11.11.

Setting the boiler's integral pump: The boiler's integral pump is factory set to operate in both C.H. and D.H.W. mode. Where an external pump is incorporated into the system design the integral pump may be disconnected in C.H. mode by fitting dip switch '5' into the "ON" position, see diagram 11.11.

Setting the 45 seconds delay: The boiler is factory set to exclude the delay of 45 seconds before re-ignition between the closing of a hot water tap and CH start-up. This delay can be set to 45 seconds by setting dip switch '3' into the "OFF" position', see diagram 11.10 and 11.11.

255 seconds delay setting: The boiler is capable of up to 255 seconds ignition delay (anti cycling time) before re-ignition following burner shut down on the primary hydraulic water reaching its set temperature. This delay can be increased up to a maximum of 255 seconds by turning potentiometer 'P5' clockwise, see diagram 11.12.

Pump working mode setting: The boiler has a factory set to operate the pump for pre-purge and post-purge times (45 secs). This delay can be excluded by fitting dipswitch '2' into "ON" position, see diagram 11.10 and 11.11. However, this may then cause the boiler over-heat thermostat to trip out.

Setting the Heating output: The Betacom 24c and 30c boilers are factory set to give maximum CH heating output. The maximum heat output for heating is pre-set on 'P2' potentiometer, see diagram 11.12. The adjustment for max CH has no effect on max. DHW capacity of the boiler. Ignition capacity can be increased /decreased by turning 'P4' potentiometer clockwise / counter-clockwise. Boiler type is pre-set on Dip Switch '8' "OFF" position denotes 24 kW, and "ON" position denotes 28 kW.

Dipswitch 1 and 7 must always be in the "OFF" position.

Dipswitch 4 must always be in the "OFF" position.

Potentiometer 7: No adjustment required.

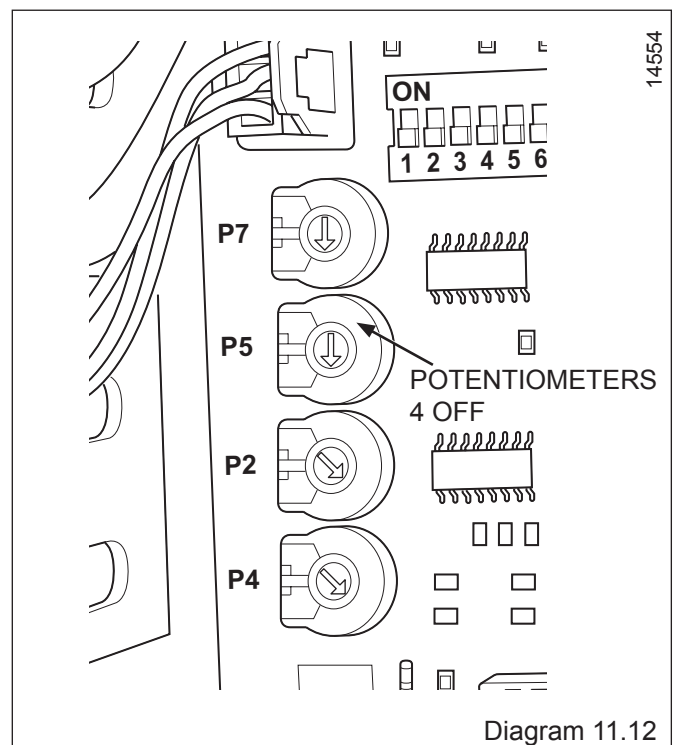
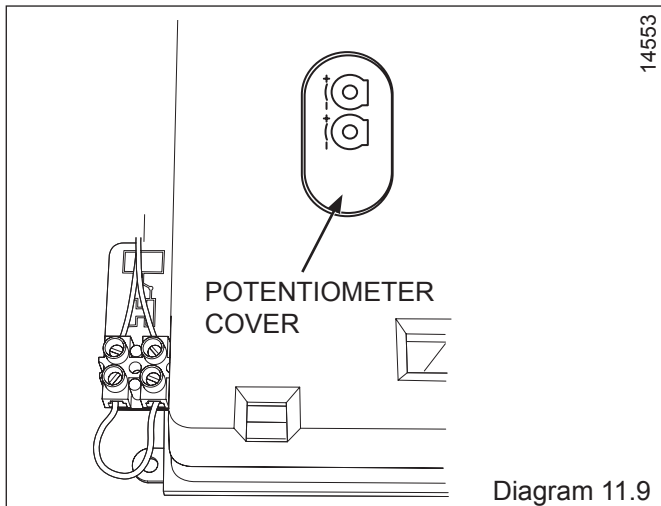
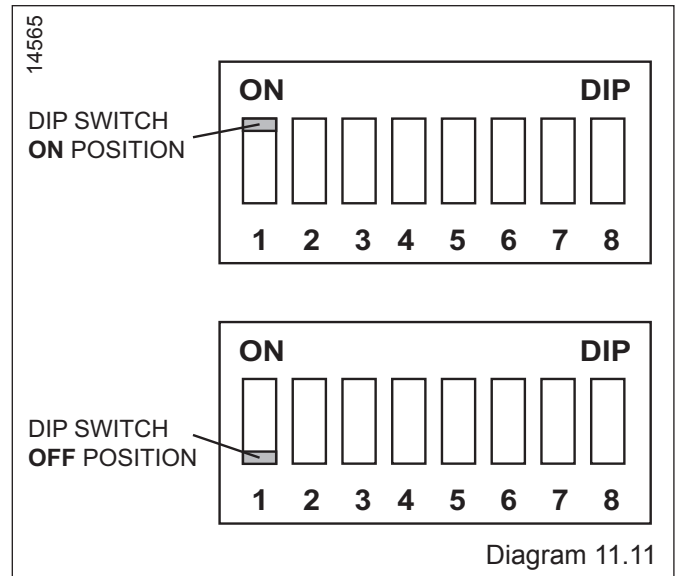
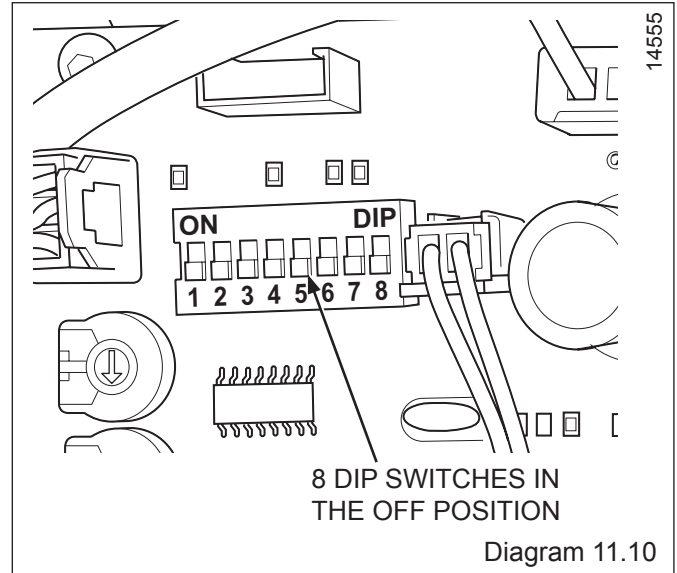

11 Commissioning

11.8 Completion

GB: It is a requirement that the “Benchmark” Installation, Commissioning and Service Record is completed and left with the user.

IE: it is necessary to complete a “Declaration of Conformity” to indicate compliance to I.S.813. An example of this is given in the current edition of I.S.813.

11.9 Instruct the User

- Demonstrate, then instruct the User about the lighting procedure and heating system controls operation.
 - Advise that to ensure the continued efficient and safe operation of the boiler it is recommended that it is checked and serviced at regular intervals. The frequency of servicing will depend upon the installation conditions and usage, but in general, once a year should be enough.
 - Draw attention, if applicable, to the current issue of the Gas Safety (Installation and Use) Regulations, Section 35, which imposes a duty of care on all persons who let out any property containing a gas appliance in the UK.
 - The user shall not interfere with or adjust sealed components.
 - It is the Law that any servicing is carried out by a **competent person** approved at the time by the Health and Safety Executive.
 - Advise the user that, like all condensing boilers this appliance will produce a plume of condensation from the flue terminal in cool weather. This is due to the high efficiency and hence low flue gas temperature of the boiler.
 - Advise the user of the precautions necessary to prevent damage to the system, boiler and the building, in the event of the heating system being out of use during frost or freezing conditions.
 - Advise the user that the permanent mains electrical supply SHOULD NOT be switched off, as the built in frost protection and pump saver program will not operate.
 - Advise the User if the mains electricity and gas are to be turned off for any long periods during severe weather, it is recommended that the whole system, including the boiler, should be drained to avoid the risk of freezing.
- NOTE: Sealed System:** Contact your installation/servicing company as draining, refilling and pressurising MUST be carried out by a **competent person** approved at the time by the Health and Safety Executive.
- Leave these instructions and the ‘Benchmark’ Installation, Commissioning and Service Record with the user.

11 Commissioning - Nat. Gas (G20) to LPG (G31) Conversion

11.10 LPG CONVERSION - all models

IMPORTANT: Gas conversion must be carried out by a **competent person** approved at the time by the Health and Safety Executive.

Isolate the boiler from both the Gas and Electricity supplies. The burner must be removed from the boiler by removing the front panel, hermetic chamber cover and combustion chamber cover. Remove the two securing screws, one on each side of the burner, see diagram 11.13.

The old injector bar (manifold) must be removed.

The ignition electrode and flame (ionisation) electrode cables must be removed by opening the control panel and gaining access to the PCB. Disconnect the plugs of the ignition and flame (ionisation) electrodes, see diagram 11.15.

Fit new injector bar (manifold), new sealing washer and tighten, ensuring that the injector size is marked 0.75 mm for LPG (both for Betacom 24c and Betacom 30c)

Fit burner and re-assemble.

The joint must be checked for Gas Tightness.

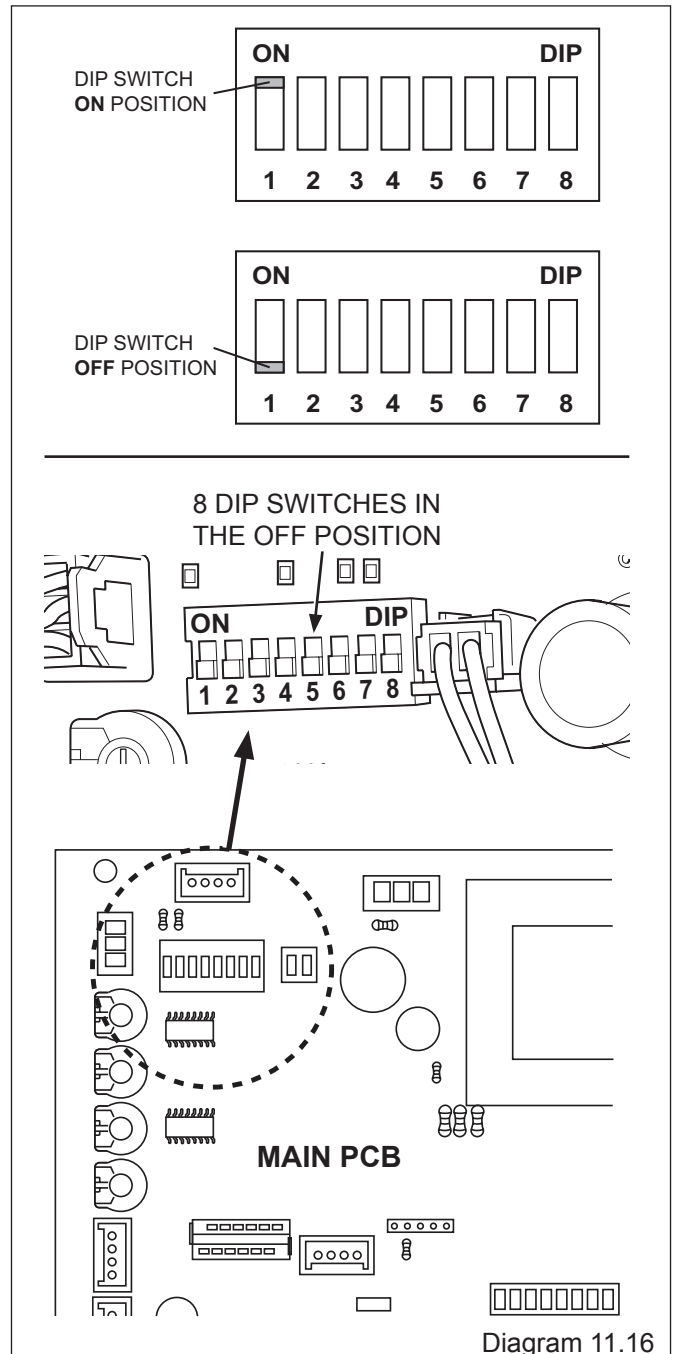
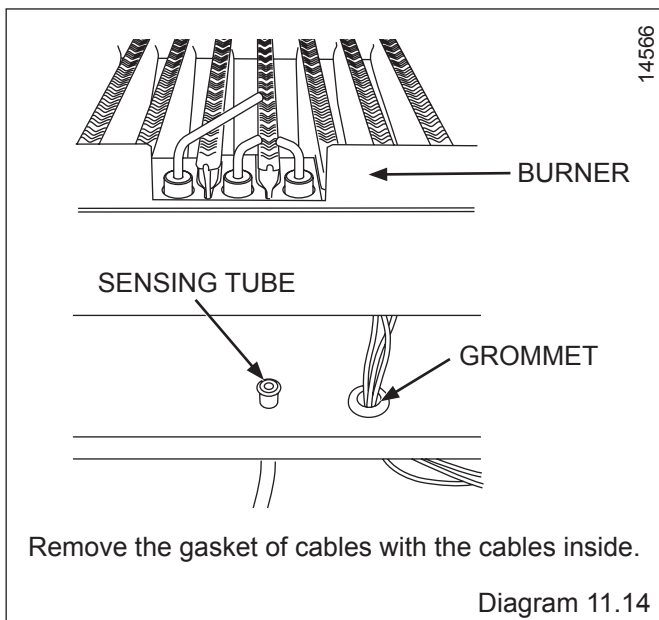
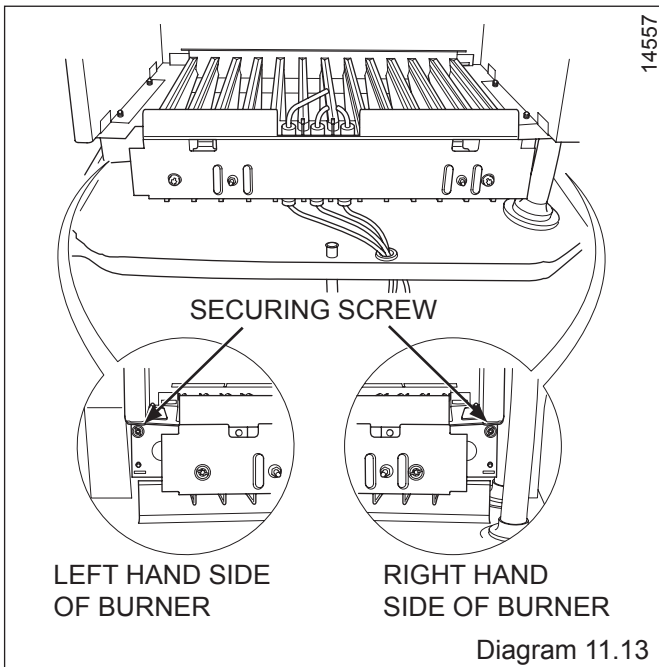
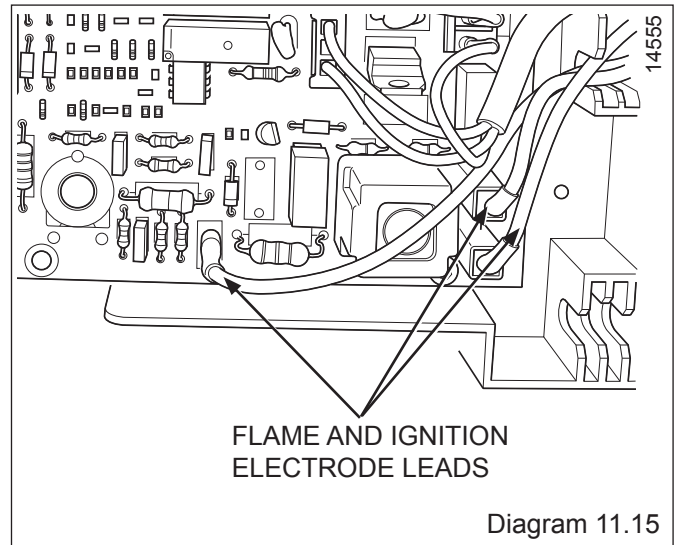

11 Commissioning - Nat. Gas (G20) to LPG (G31) Conversion

Factory settings for DIP switches								
	DS1	DS2	DS3	DS4	DS5	DS6	DS7	DS8
Betacom 24c NG	OFF	OFF	OFF	OFF	OFF	OFF	OFF	OFF
Betacom 24c LPG	OFF	OFF	OFF	OFF	OFF	OFF	ON	OFF
Betacom 30c NG	OFF	OFF	OFF	OFF	OFF	OFF	OFF	ON
Betacom 30c LPG	OFF	OFF	OFF	OFF	OFF	OFF	ON	ON

Dip switch 7 must be in the ON position for LPG and OFF for NG.

Dip switch 8 must be in the OFF position for Betacom 24c and ON for Betacom 30c.

To set the Minimum Setting:

Remove one lead from the gas valve modulating coil, see diagram 11.17.

Turn boiler's function switch to the 'winter' position (both CH and DHW).

Turn the Central Heating temperature control knob to the maximum position.

Connect a suitable pressure gauge to the pressure outlet on the gas valve, see diagram 11.18.

Remove the protective cover from the gas valve.

Turn inner adjuster with a flat blade screwdriver.

Turn Clockwise: to increase burner pressure.

Turn Counter-Clockwise: to decrease burner pressure.

After adjustment, connect electrical lead and protective cover.

To set the Maximum Setting:

Connect a suitable pressure gauge to the burner pressure test point on the gas valve.

Remove the protective cover from the gas valve adjuster.

Connect a suitable pressure gauge to the pressure outlet of the gas valve.

Turn boiler's function switch to the 'winter' position.

Turn the Central Heating temperature control knob to the maximum position.

Push the ball inside gas valve modulating coil using a sharp pointed tool.

Turn outer nut with a 10mm spanner keeping the tool pushed in:

Turn Clockwise: to increase burner pressure.

Turn Counter-Clockwise: to decrease burner pressure.

After adjustment, connect electrical lead and protective cover.

	Betacom 24c		Betacom 30c	
	NG (G20) mbar	LPG (G31) mbar	NG (G20) mbar	LPG (G31) mbar
Burner operating pressure (minimum)	2.5	8.0	2.3	6.0
Burner operating pressure (maximum)	12.5	36.5	14	36.0

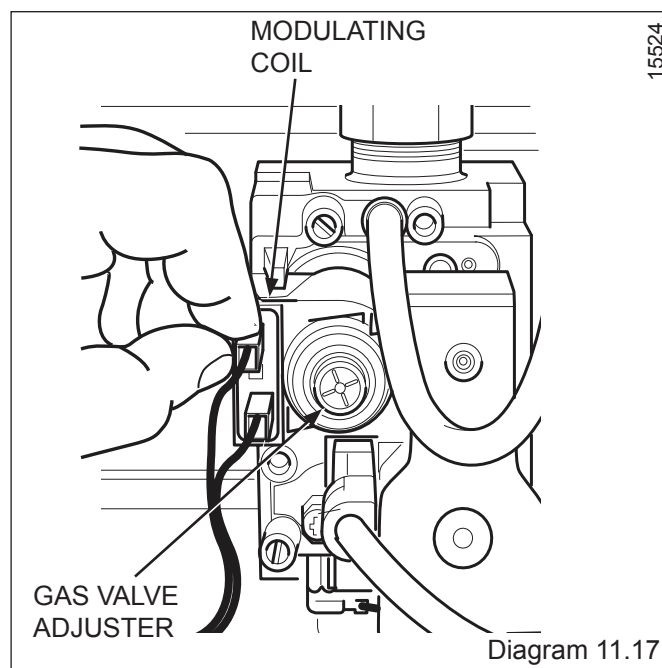

Diagram 11.17

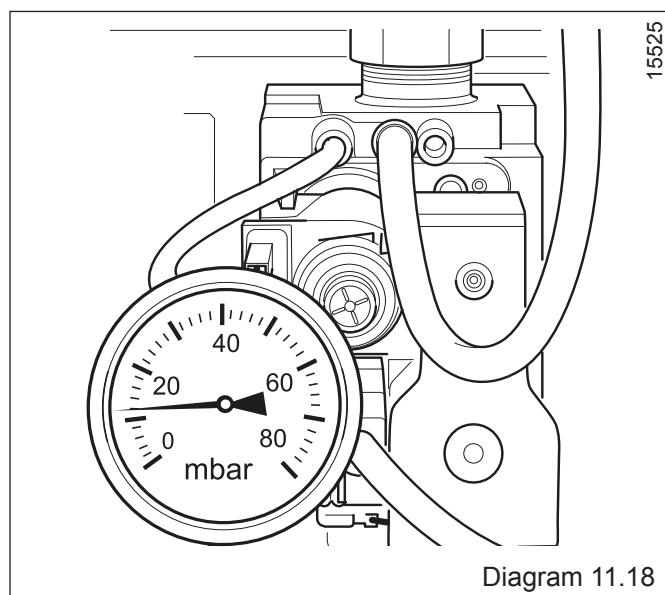

Diagram 11.18

12 Servicing

IMPORTANT NOTES:

1. To ensure the continued efficient and safe operation of the boiler it is recommended that it is checked and serviced at regular intervals. The frequency of servicing will depend upon the particular installation and usage, but in all cases the boiler must be serviced at least once a year.
2. It is the Law that any servicing is carried out by a **competent person** approved at the time by the Health and Safety Executive.
3. Before commencing with a service or replacement of parts the boiler should be isolated from the electrical supply and the gas supply should be turned off at the gas service isolation valve.
4. When replacing a part on this appliance, use only spare parts that you can be assured conform to the safety and performance specification that we require. Do not use reconditioned or copy parts that have not been clearly authorised by Glow-worm.
5. If any electrical connections have been disconnected and after their connection, checks to the earth continuity, polarity, short circuit and resistance to earth must be repeated using a suitable multimeter.
6. On completion the "Benchmark" Service Record should be completed.

General Inspection

Prior to, during servicing and after any maintenance or changed parts, the following must be checked.

- The integrity of the flue system and flue seals.
 - The integrity of the appliance combustion circuit and relevant seals.
 - Electrical, gas and water connections.
 - System pressure.
 - the combustion performance, refer to the following procedure.
 - The operational gas inlet pressure and gas rates, refer to the commissioning section, paragraph 11.5.
- Correct any fault before continuing.

- Ensure that the gas analyser is set to the correct fuel setting.
 - Select the constant central heating with DHW function by turning the function switch, refer to commissioning section. The boiler should fire automatically.
- NOTE:** Safe combustion can only be verified by measuring CO/CO₂ ratio. This ratio must not exceed 0.0008.

Burner

Refer to Commissioning, section 11.5 "Setting operational pressure".
Check that the burner pressure at maximum and minimum rate, is as the value in the boiler specification table on page 8. If incorrect, adjust as necessary.

COMPETENCY TO CARRY OUT THE CHECK OF COMBUSTION PERFORMANCE

NOTE: BS 6798: 2009 Specification for installation and maintenance of gas-fired boilers of rated input not exceeding 70KW net advises that:

- The person carrying out a combustion measurement must be assessed as competent in the use of a flue gas analyser and the interpretation of the results.
- The flue gas analyser used should be one meeting the requirements of BS927 or BS-EN50379-3 and be calibrated in accordance with the analyser manufacturers' requirements.
- Competence can be demonstrated by satisfactory completion of the CPA1 ACS assessment, which covers the use of electronic portable combustion gas analysers in accordance with BS 7967, parts 1 to 4.

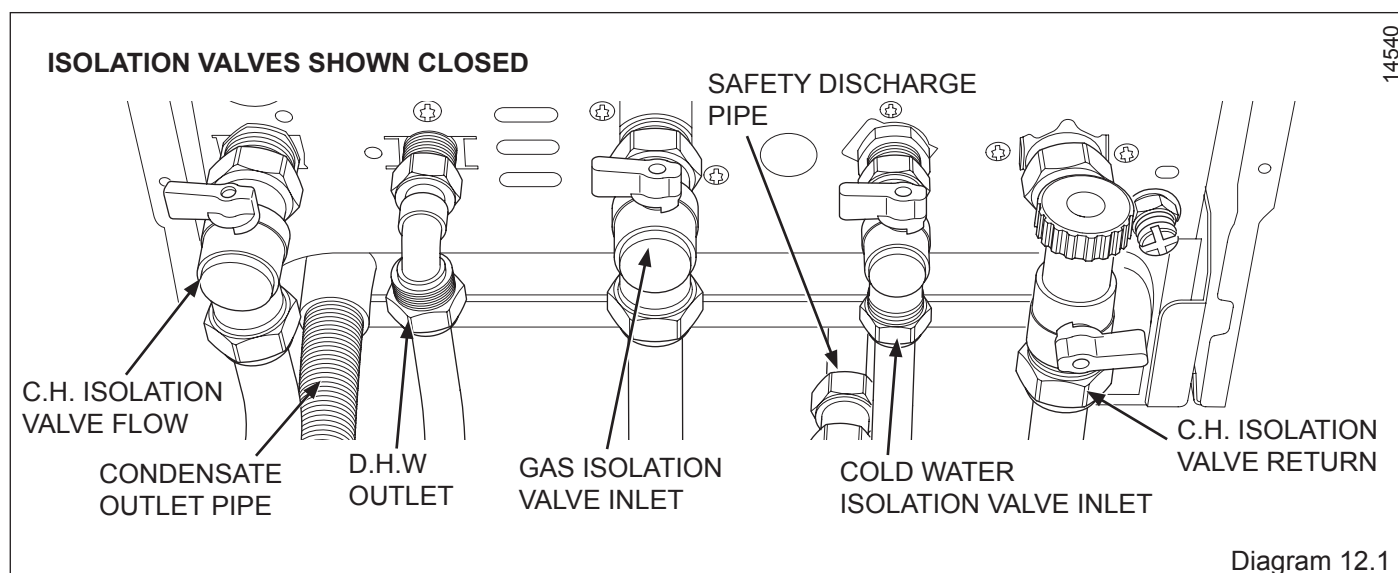

12 Servicing

COMBUSTION CHECK AND SETTING GAS VALVE

- Remove the front casing panel, see diagram 10.1 and hinge down the control box. Taking care not to touch any internal components, proceed as follows:
- Connect the CO₂ combustion analyser to the relevant test point.

While adjusting the burner pressure at maximum and minimum, combustion products can be checked if required, according to the table below:

Appliance	Combustion Products					
	CO ₂ (Vol - %)				CO (ppm)	
	Natural gas tolerance		Propane tolerance		Natural gas tolerance	Propane tolerance
	Max	Min	Max	Min		
Betacom 24c	8.60 ± 0.5	3.85 ± 0.5	9.60 ± 0.5	4.40 ± 0.5	< 400	< 400
Betacom 30c	8.10 ± 0.5	2.90 ± 0.5	9.30 ± 0.5	3.35 ± 0.5	< 400	< 400

Should any CO₂ value exceed the value in the table, investigation of the cause such as cleaning the heat exchanger and checking the integrity of the flue, must be carried out.

GAS RATE CHECK

The boiler is fitted with a fully modulating automatic gas valve. With all other gas appliances turned off measure the gas rate at the gas meter. Check that the gas rate is as stated in the table below:

Appliance	Maximum net heat input in kW	Gas rate
		Natural gas in (m ³ / h)
		nominal
Betacom 24c	25,7	2,72
Betacom 30c	28,5	3,02

COMPLETION

If it is not possible to achieve the required results for either the combustion or gas rates, it will be necessary to complete a full service of the appliance and then repeat the combustion check procedure. If after servicing and adjustment of the appliance the combustion values are still unacceptable and after further remedial work has been carried out, the appliance must be disconnected until the CO/CO₂ ratio is acceptable. Advice can be sought from the Glow-worm Technical Helpline.

12.1 Servicing

All routine servicing requirements can be achieved by the removal of the front panel and inner casing panel, see diagram 12.2.

Before commencing with a service or replacement of parts. The boiler should be isolated from the electrical and gas supplies.

- Remove the front casing panel by removing two screws at the bottom of the boiler and by lifting the front casing panel up to release from the retaining hooks, see diagram 10.1.
- Remove the boiler inner casing panel by removing two screws and by lifting the boiler inner casing panel up to release from the retaining lugs, see diagram 12.2.
- Remove the side panels by removing the screws on the upper and lower sides. Remove the panels by swinging them out and lifting them up, see diagram 12.3.
- Remove the combustion chamber cover by removing six screws, see diagram 12.4.

12 Servicing

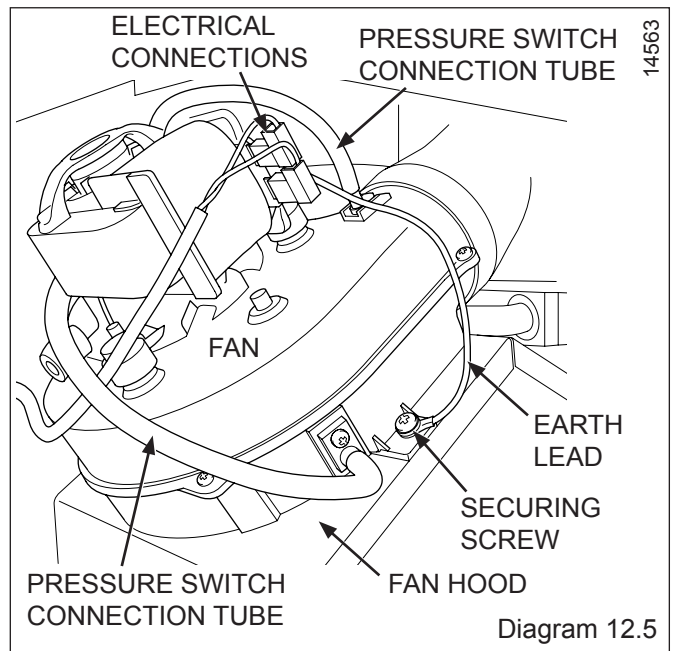
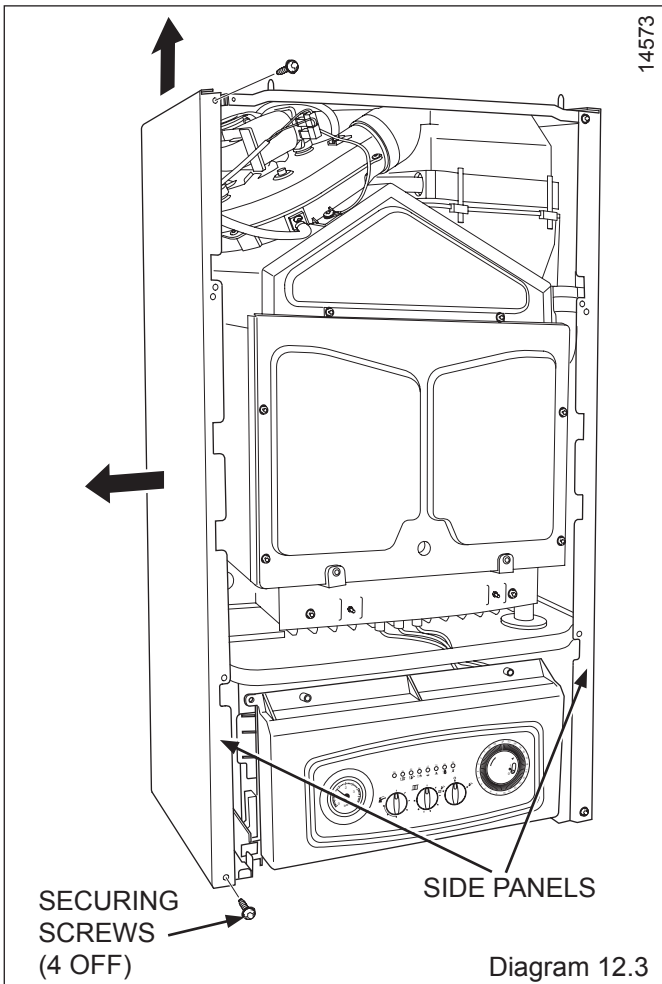
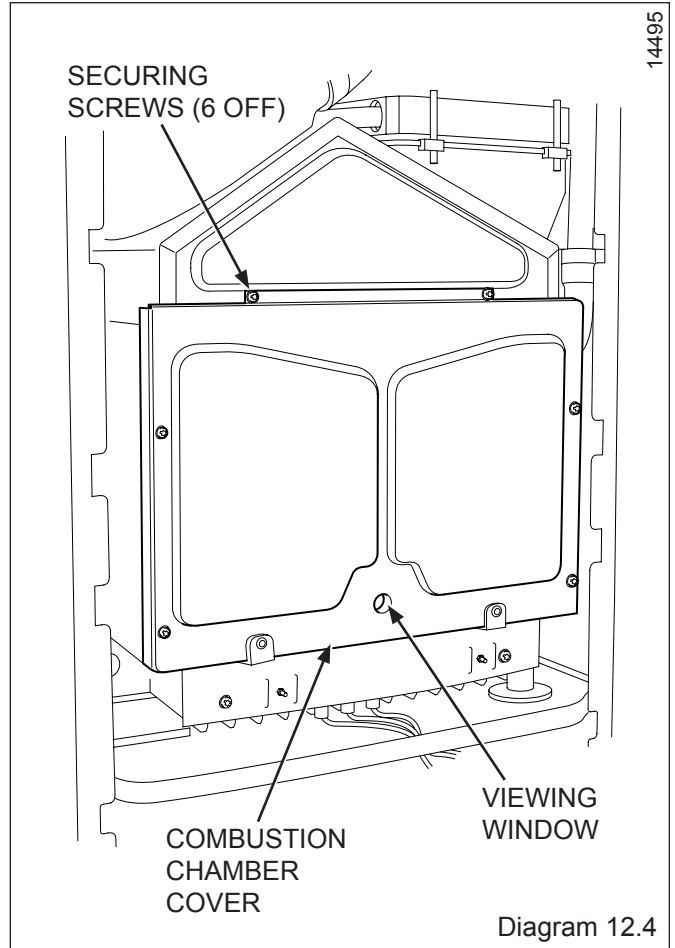
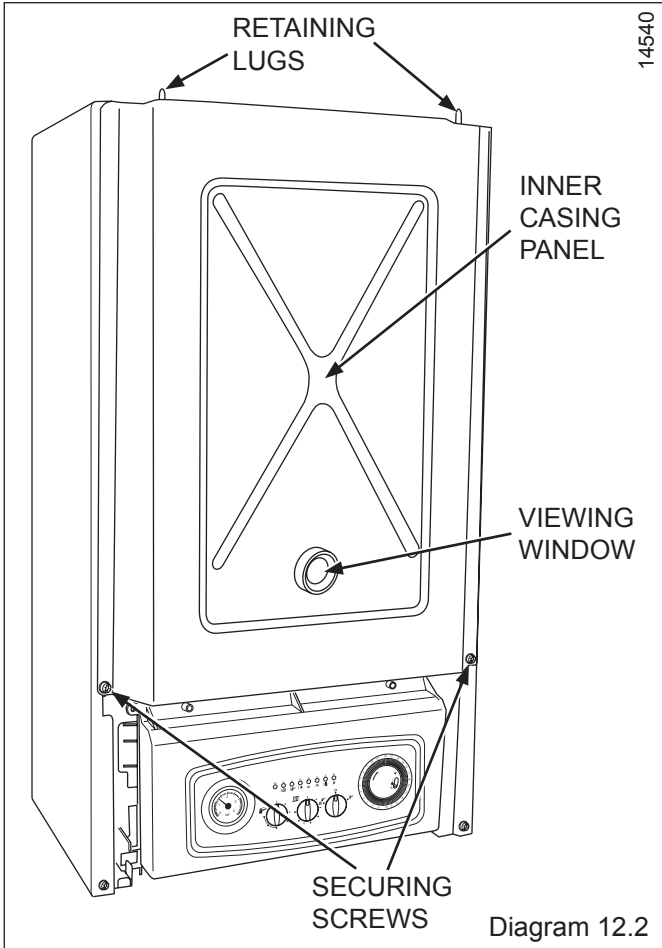

12 Servicing

12.2 Fan removal

Disconnect the electrical connections and air pressure switch connection tubes from the fan, remove the fan securing screw and withdraw fan from fan hood with its 56° bend, see diagram 12.5.

12.3 Burner removal

Remove the burner assembly from the combustion chamber as follows:

Pull off the ignition and flame electrode leads from mains circuit board and remove the wires with grommet from the combustion chamber base, see diagrams 12.6 and 12.7. Remove the burner-retaining screws at the sides and remove the burner, see diagram 12.8.

12.4 Visually check

For debris/damage and clean/replace as necessary the following items:

Heat exchanger, Burner, Fan/compartment Electrodes and Insulation/gaskets

IMPORTANT: Clean the heat exchanger using a soft brush or vacuum cleaner. Do not use any tool likely to damage painted finish of heat exchanger.

Clean the burner by washing in soapy water. Allow to dry thoroughly before re-fitting.

Do not use wire or a sharp instrument to clean the burner injectors.

Ensure the ignition electrode gap is set to 4 mm, see diagram 12.7.

12.5 Cold water inlet filter

The boiler is fitted with a cold water inlet filter which must be inspected on each service, see diagram 12.9.

To access the filter:

Close the isolating valve on the boiler's cold water domestic inlet by turning the valve head fully clockwise.

Open one or more hot water taps to drain the domestic hot water circuit.

Disconnect the cold water inlet connection to the boiler.

Clean and inspect the filter, replace if necessary as described in replacement of parts section 14.19.

Re-fit the filter and reinstate the cold water inlet connection to the boiler, fit new gasket as required.

Fully open the isolating valve on boiler's cold water inlet and check for leaks.

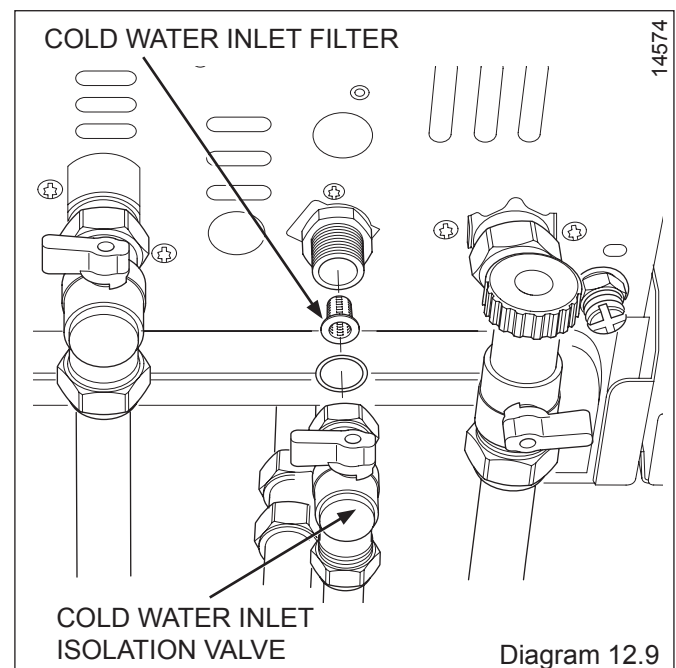
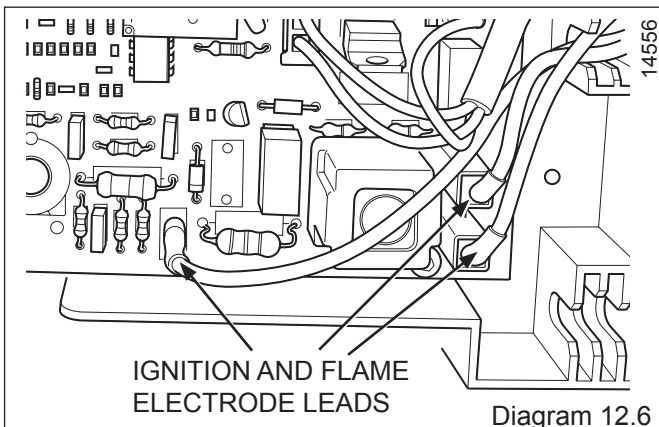
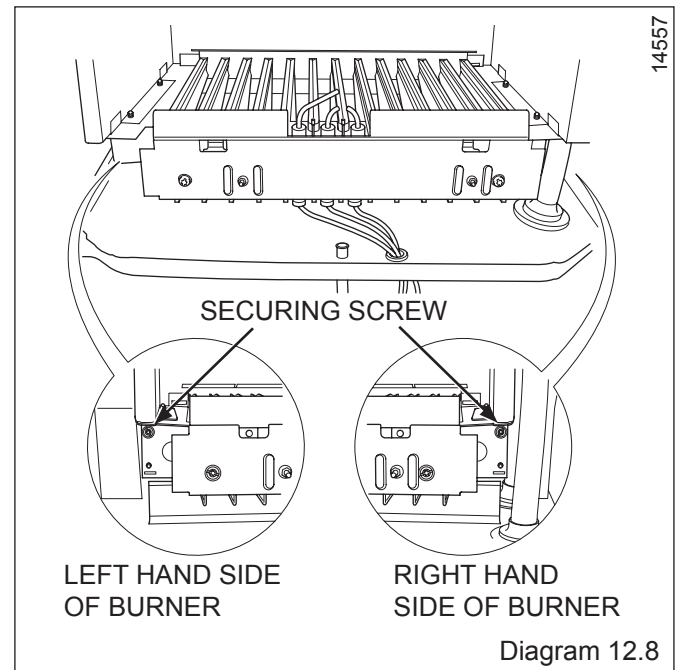
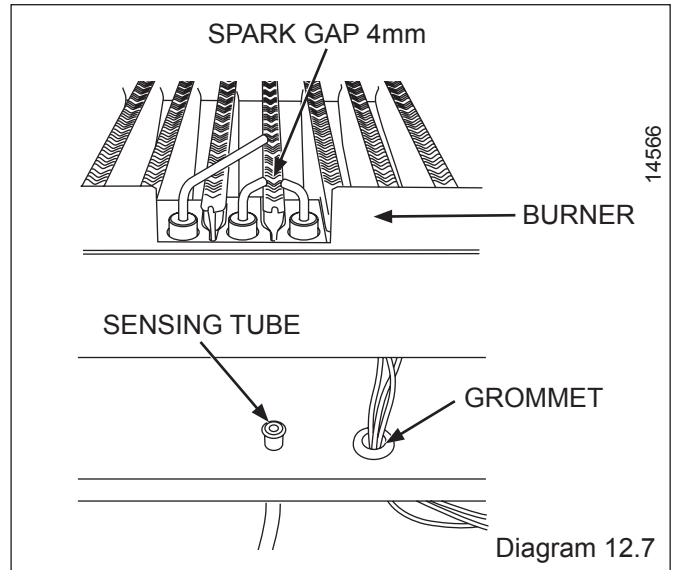

13 Fault finding

14593

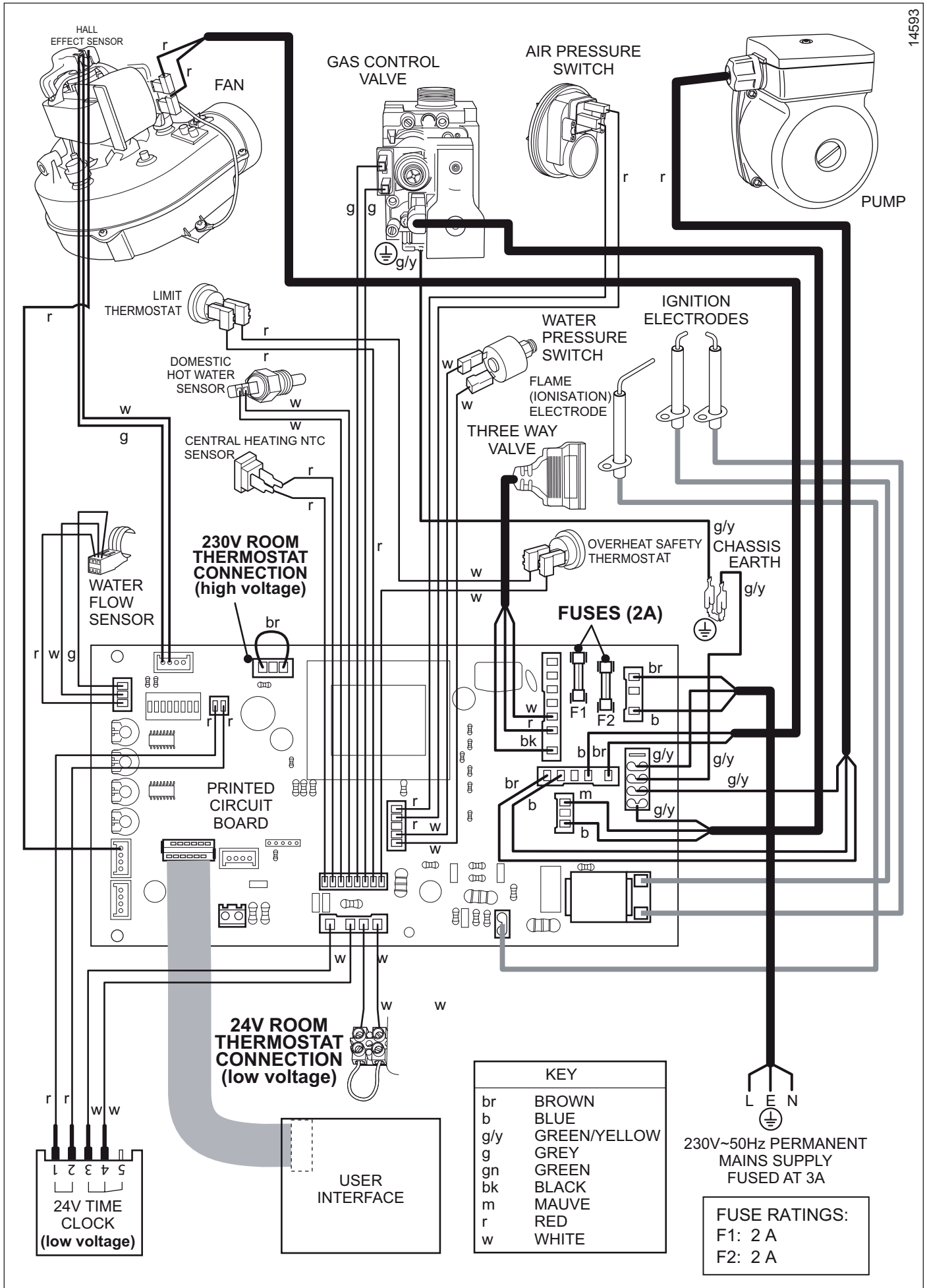

KEY	
br	BROWN
b	BLUE
g/y	GREEN/YELLOW
g	GREY
gn	GREEN
bk	BLACK
m	MAUVE
r	RED
w	WHITE

FUSE RATINGS:
 F1: 2 A
 F2: 2 A

13 Fault finding

13.1 Preliminary fault finding

The following checks should be performed before proceeding onto specific diagnostics:

Check the external electrical supply to the boiler is on and a supply of 230V is present at the 'L' and 'N' terminals.

Check the electrical installation and boiler, carry out tests for earth continuity, polarity, short circuit and resistance to earth, using a suitable multimeter.

An aid to test

Remove the front casing panel, see diagram 10.1 and hinge down the control box.

Unclip to gain access to the mains circuit board, see diagram 10.4.

Carry out the tests on the mains circuit board, see diagram 13.1.

Check chassis earth at a bare metal point on the boiler.

Check that there is a gas supply to the boiler and the gas service isolation valve is turned on, see diagram 13.2.

Check pressure at the gas service isolation valve, refer to section 11.5.

Check that the heating system pressure indicates at least 1.0 mbar, if not, fill and vent the system as described in section 11.2.

Check that all external controls are on.

13.2 Re-set function

Should the boiler lock out at any time, please check the gas supply and ionisation probe position, the boiler may be re-started by switching to standby "O" position waiting 15-30 seconds and switching back to its previous position once the fault has been eliminated, see diagram 11.4.

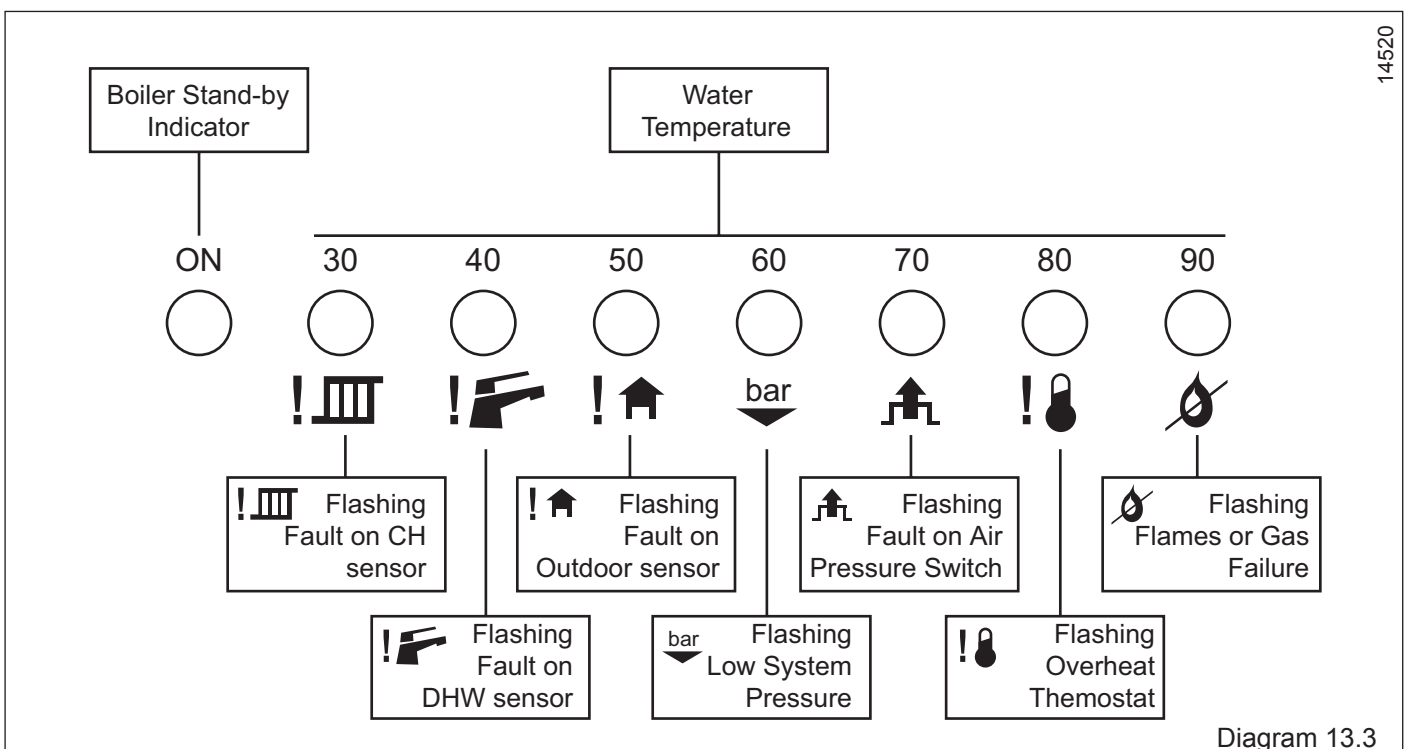
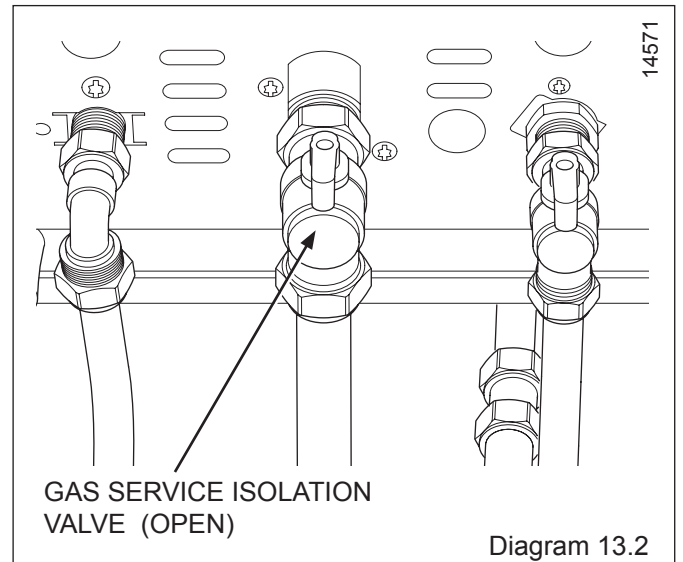
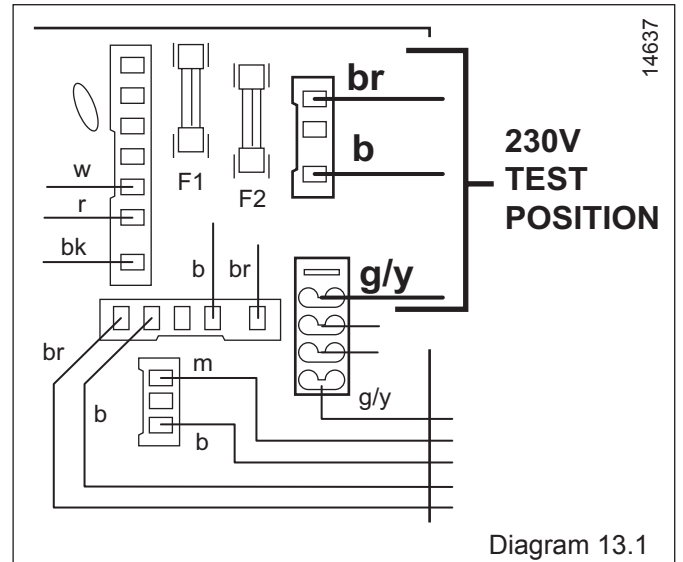

13 Fault finding

13.2 Fault finding chart 1. Check electrical supply central heating sensor and frost protection.

14496

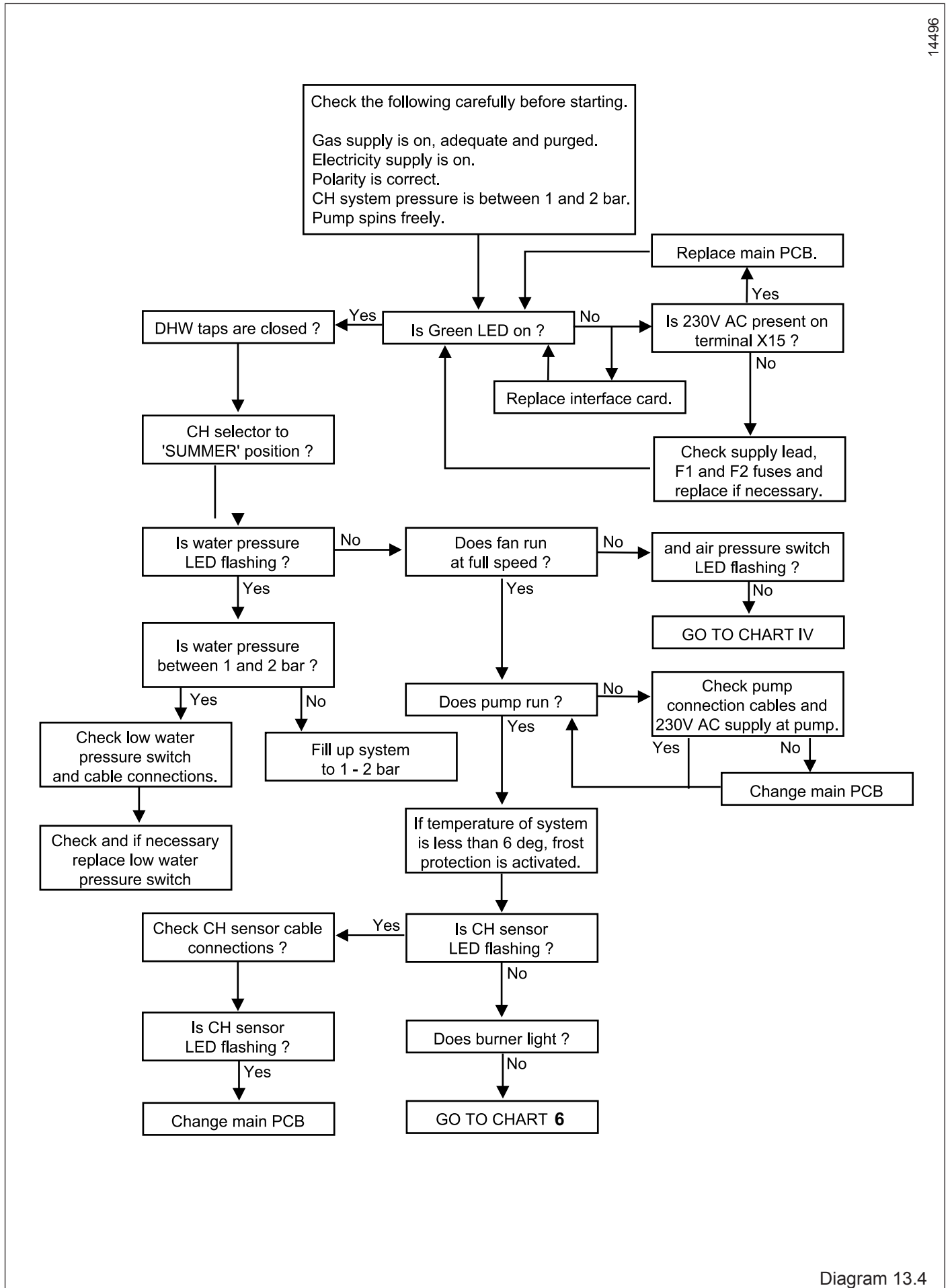
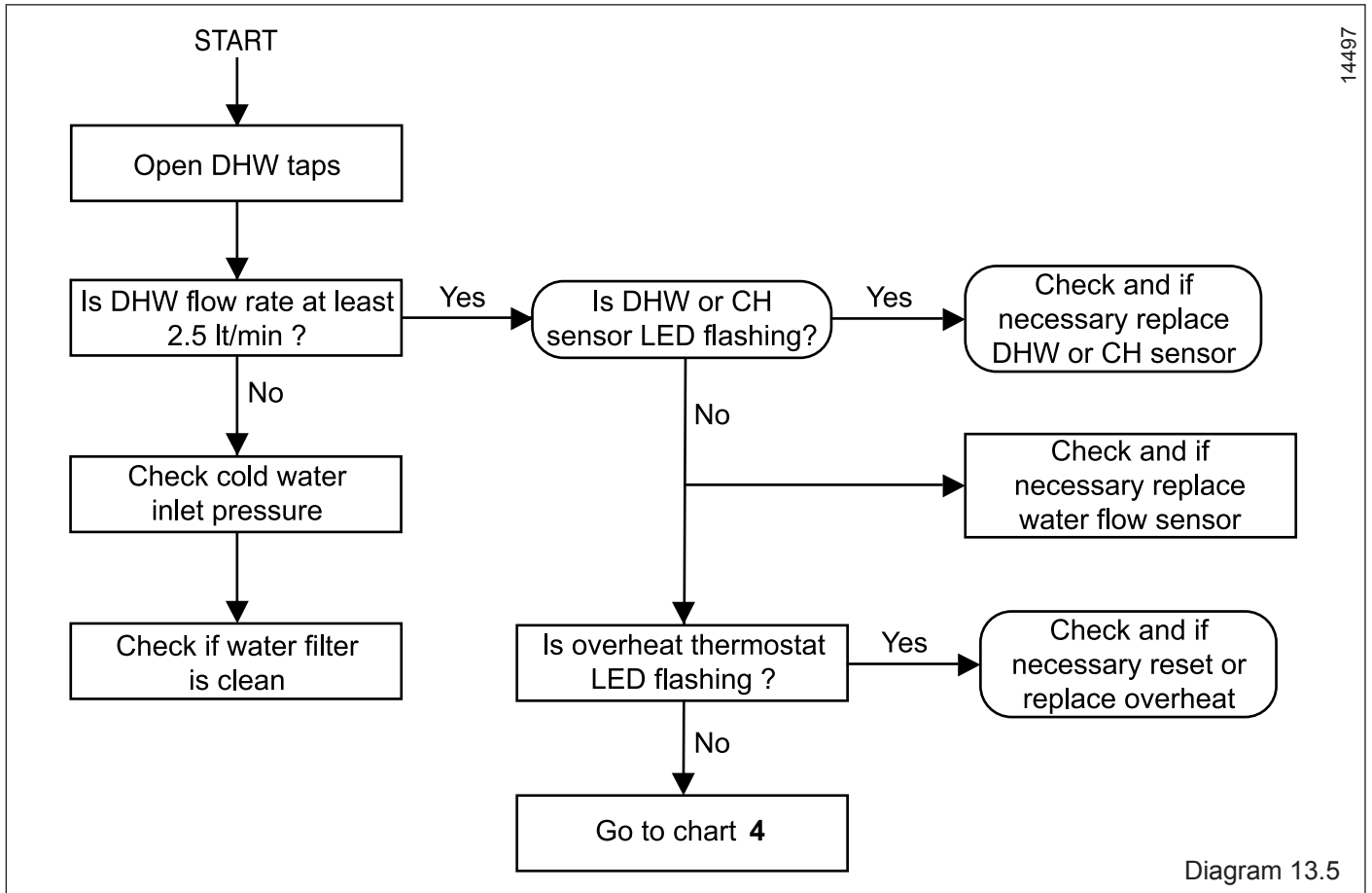

Diagram 13.4

13 Fault finding

13.2 Fault finding chart 2. Check domestic hot water operation.



13.3 Fault finding chart 3. Check central heating operation.

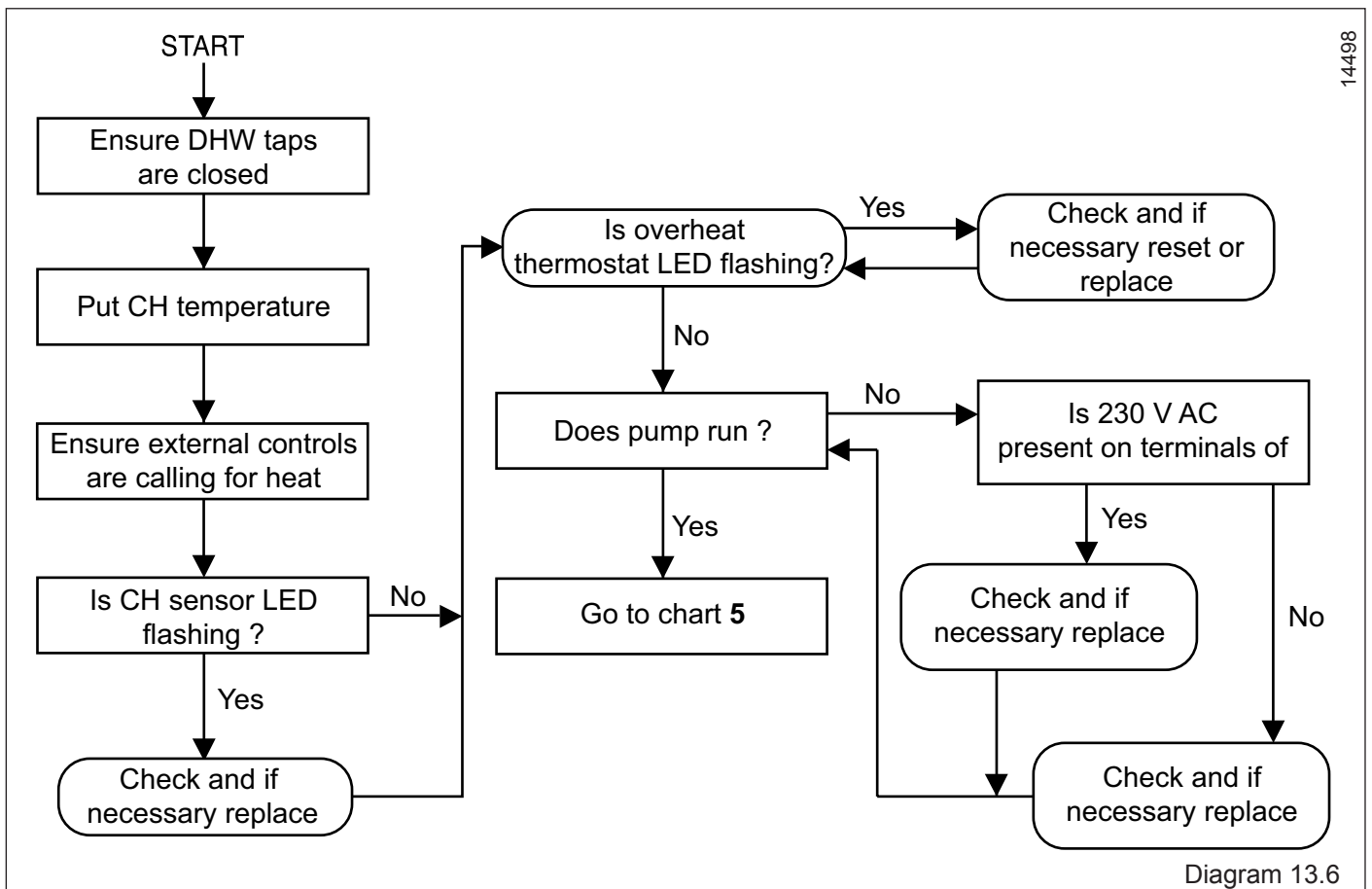

13 Fault finding

13.4 Fault finding chart 4. Check domestic hot water operation.

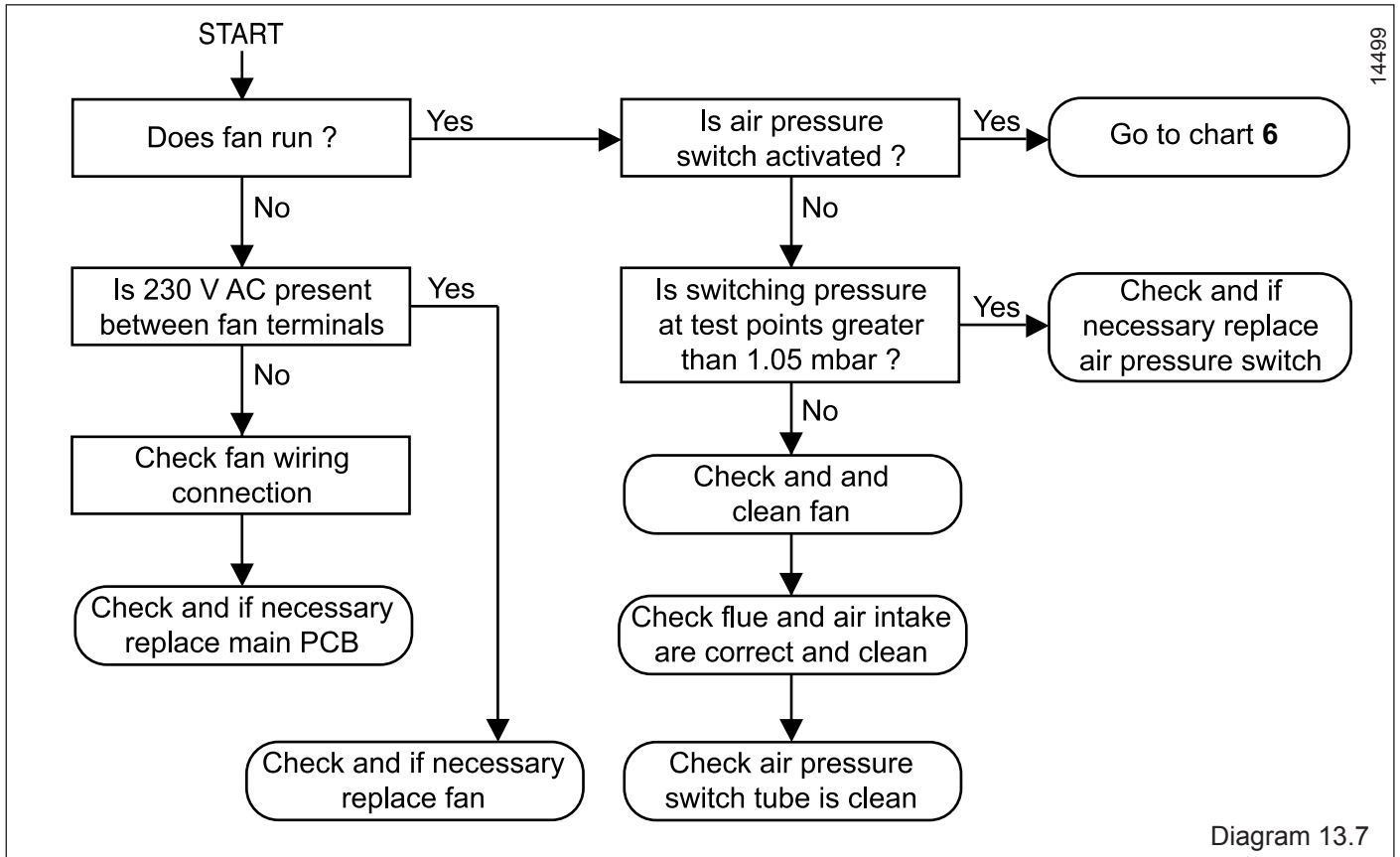

13.5 Fault finding chart 5. Check domestic hot water and central heating modulation

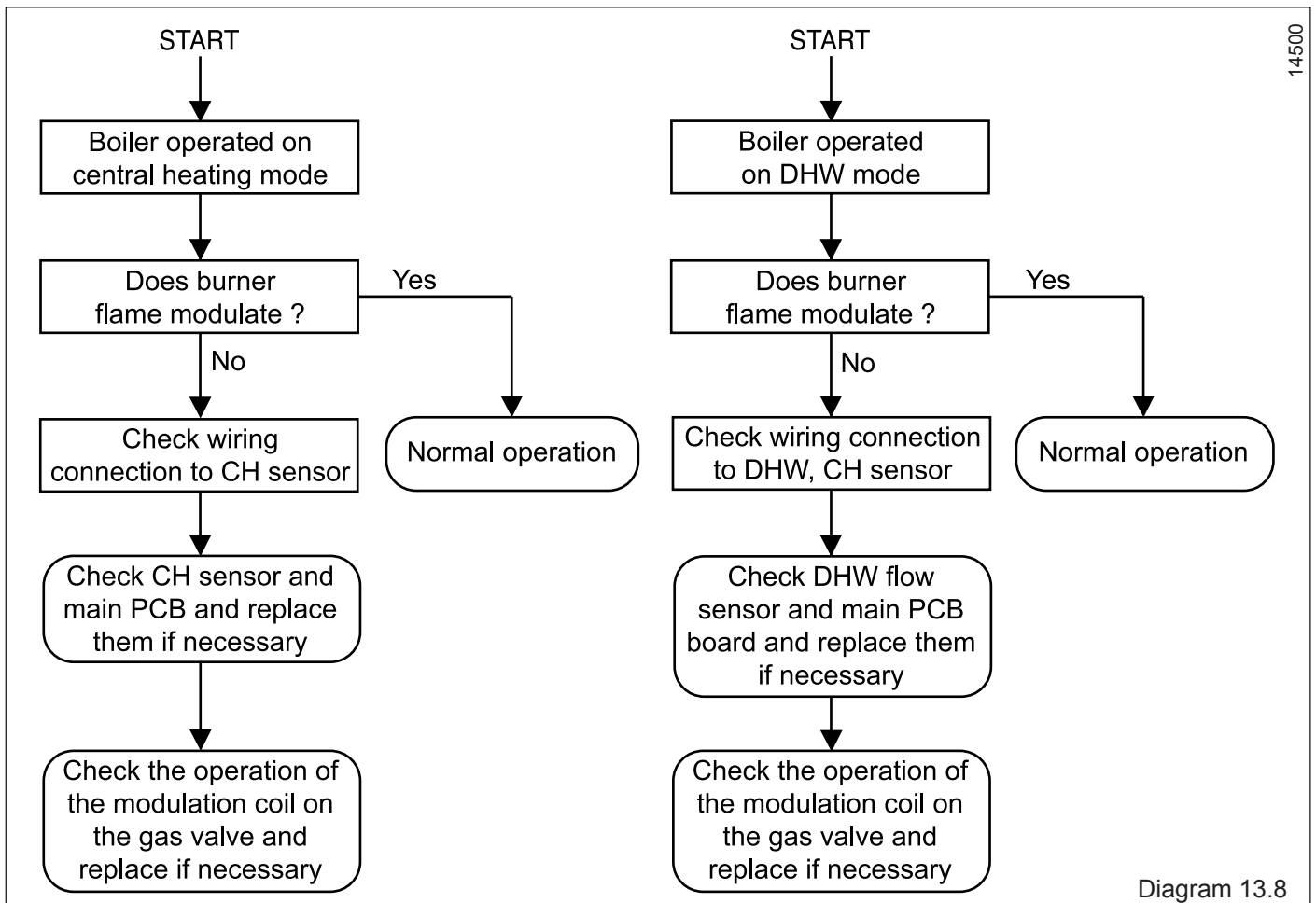

13 Fault finding

13.6 Fault finding chart 6. Check ignition system.

15558

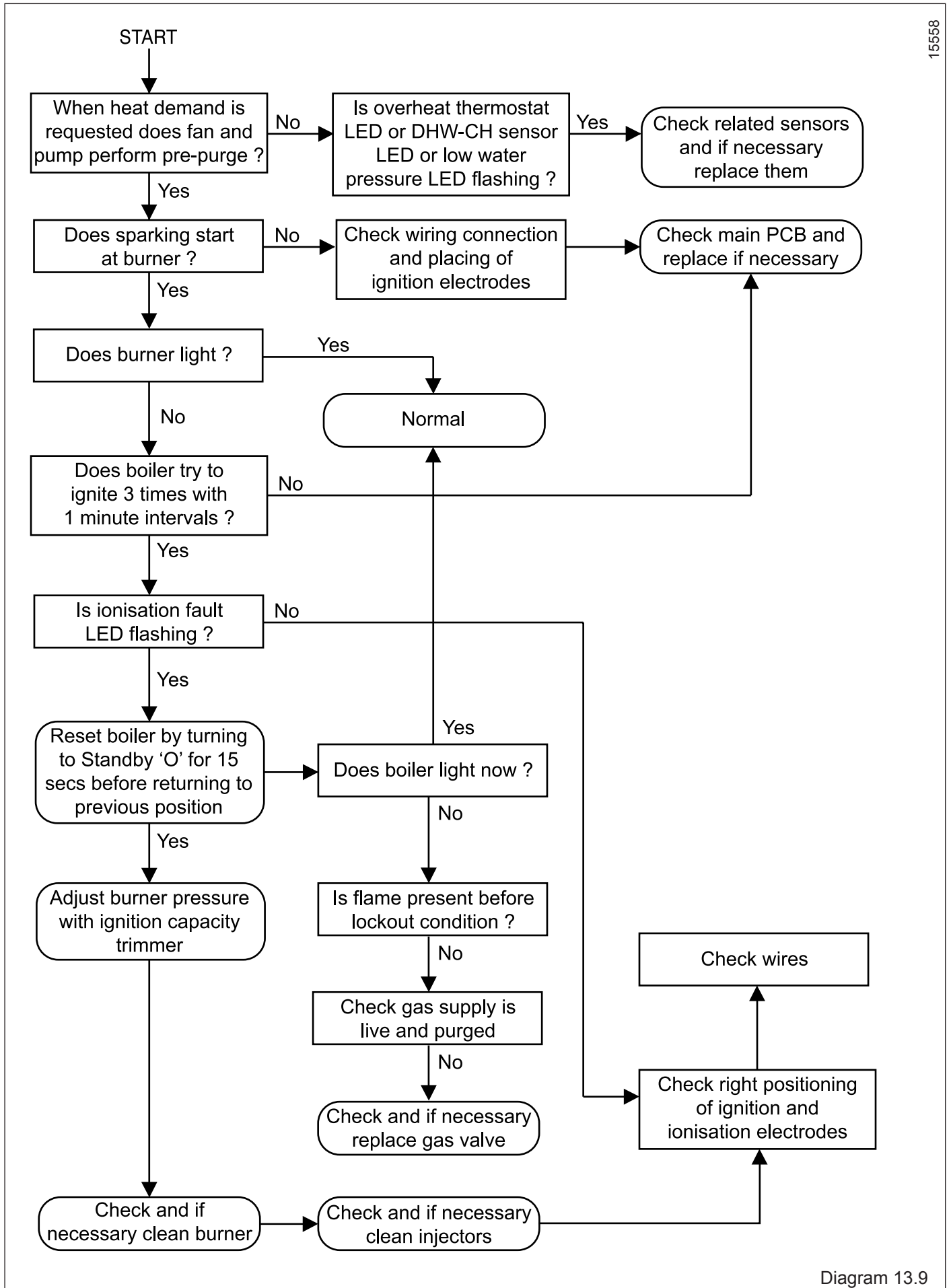

Diagram 13.9

14 Replacement of parts

14.1 General

Replacement of parts must be carried out by a **competent person**.

Before replacing any parts the boiler should be isolated from the mains electric supply and the gas should be turned off at the gas service isolation valve on the boiler.

The boiler is cold.

Ensure that components with electrical connections are disconnected before removal.

Unless stated otherwise parts are replaced in the reverse order to removal.

After replacing any parts always test for gas tightness and if necessary carry out functional test of the controls.

For replacement of parts the front casing of the boiler will need to be removed. To remove undo the two screws on the underside of the front casing and lift off the retaining lugs, see diagram 10.1.

The side panels can be removed to aid replacement of parts, see diagram 12.3.

To hinge a side panel undo and remove the two screws securing each side panel to the boiler.

14.1 Draining of Boiler

To prevent the need to drain the entire heating system when replacing the boiler's integral pump, expansion vessel, safety relief valve and pressure sensor, the boiler's hydraulic circuit may be isolated from the central heating circuit by closing the boiler's isolation valves. Opening the discharge safety valve will then drain the boiler's hydraulic circuit.

NOTE: clean the valve seat to ensure it seals before re-filling the boiler.

After replacing parts open the heating flow and return isolating valves and refill, vent and pressurise the heating circuit, refer to section 11.2.

Check for leaks.

14.2 Draining of Boiler Hot Water Circuit

Drain the Domestic Hot Water circuit by closing the cold-water isolation valve on the boiler.

Open one or more hot water taps to drain the hot water circuit. After replacing parts open the cold-water isolation valve and slowly open a hot water tap to remove air. Close the hot water tap and check for any leaks.

14.3 Domestic hot water sensor

For access, refer to section 14.1.

The domestic hot water sensor is located on the left side of the hydroblock's hot water side, see diagram 14.1.

Carefully disconnect the electrical connections from the domestic hot water sensor.

Remove the domestic hot water sensor using a 13mm spanner.

Fit the replacement domestic hot water sensor ensuring the washer is correctly fitted.

Re-fit the electrical connections to the replacement sensor.

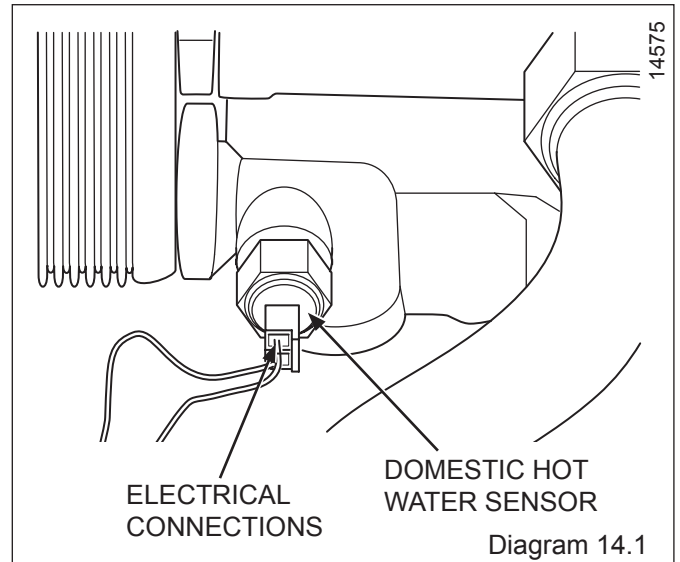

Diagram 14.1

14.4 Central heating sensor

For access, refer to section 14.1.

The C.H. sensor is located on left side of the combustion chamber on the outlet of the primary heat exchanger, see diagram 14.2.

Unclip the C.H. sensor from the pipe.

Disconnect the electrical connections from the C.H. sensor.

Fit replacement C.H. sensor.

Re-fit the electrical connections.

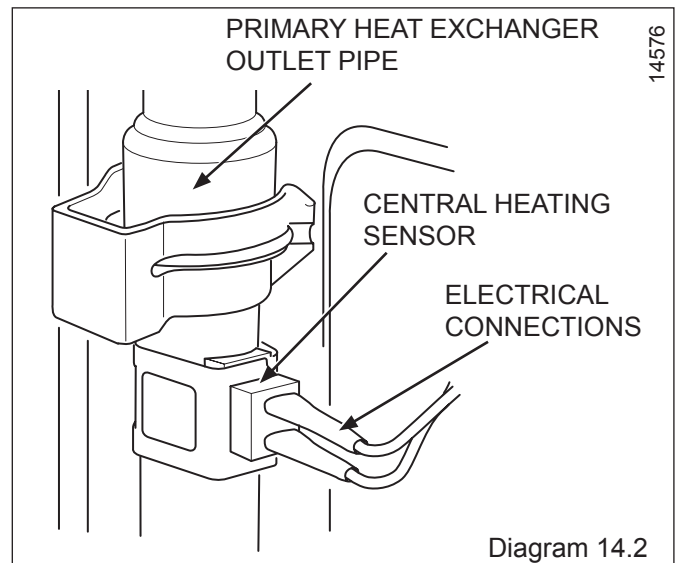

Diagram 14.2

14.5 fan unit

For access, refer to section 14.1.

Refer to section 12.2 to replace the fan.

Fit the replacement fan unit in reverse order and reconnect the electrical connections and sensing tube.

14 Replacement of parts

14.6 Air pressure switch

For access, refer to section 14.1.

The air pressure switch is located above the expansion vessel, see diagram 14.3.

Remove the sensing tubes and electrical connections from the air pressure switch, noting which tube is connected to which port.

Remove the air pressure switch by unclipping it from the bracket.

Fit the replacement air pressure switch in reverse order of removal.

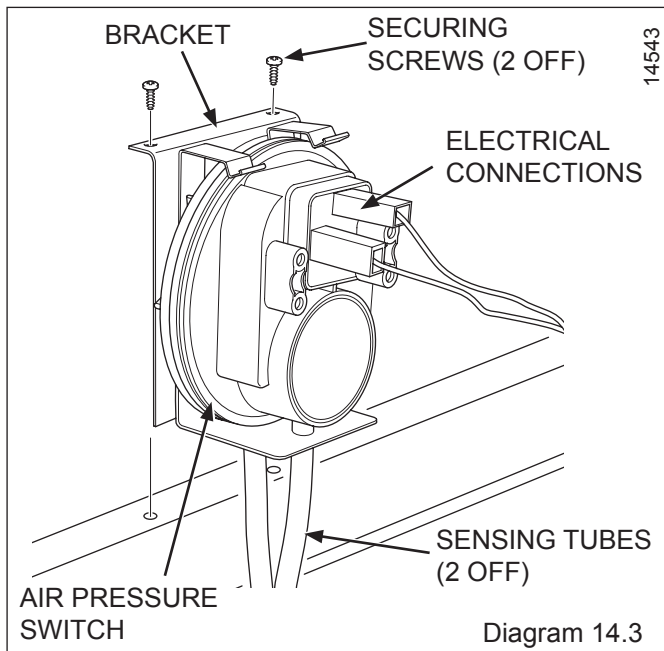

14.7 Burner

Refer to section 12.3. to replace the burner.

Retain all washers/gaskets for use on re-assembly.

Remove the burner injectors as shown in diagram 14.4.

Fit the burner injectors to the new burner injector bar and tighten, ensuring that the injector size, marked on each injector is the same as stated in the 'Boiler Specification section' page 8, for the type of gas being used.

Replace the burner bar and re-fit the burner blades (replace any damaged seals as necessary).

Fit replacement burner in reverse order.

Check gas soundness and boiler operation.

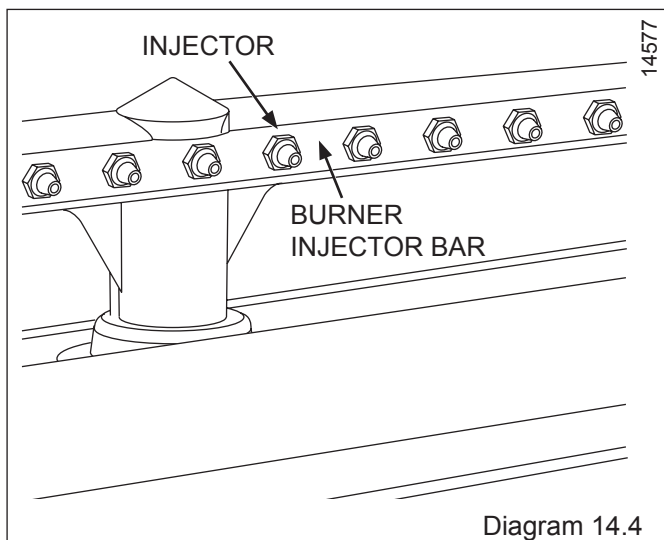

14.8 Printed circuit board

For access, refer to section 14.1.

Turn off and isolate the electrical supply.

Unclip the two front retaining clips on the controls fascia, see diagram 10.3.

Unclip and carefully pull down the control circuit board cover, see diagram 10.4.

Remove the electrical connections to the PCB by pulling carefully, noting the locations of all the terminals.

Release the four screws securing the PCB to the control panel and lift out the PCB.

Fit the replacement PCB in reverse order to removal, ensuring that the PCB electrical connections are fully pushed home.

Check and re-set as necessary the potentiometers and dip switches to the same value as the old PCB.

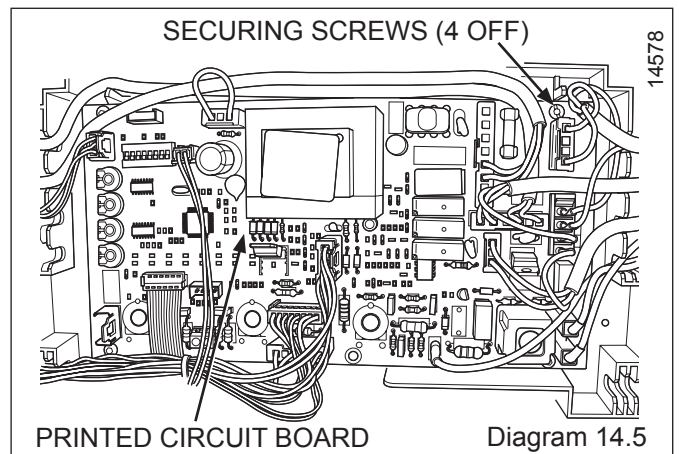

14.9 Pump head

For access, refer to section 14.1.

Drain the boiler's circuit as detailed in section 14.2.

Remove the screws, see diagram 14.6.

Pull off the motor, remove the cover and disconnect the electrical connections from cable box.

Fit the replacement motor in reverse order ensuring correct polarity of the electrical connections.

Re-open the isolating valves on the flow and return connections, refill, vent and re-pressurise the system, check for leakage.

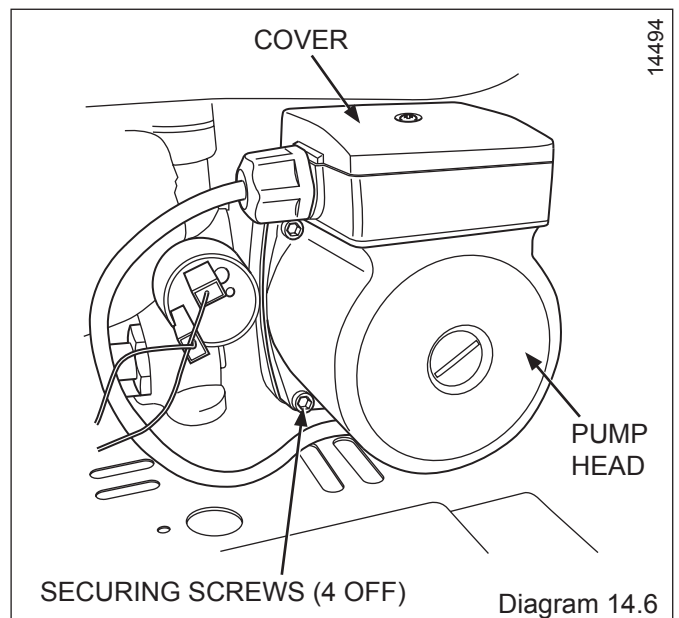

14 Replacement of parts

14.10 Pump body

For access, refer to section 14.1.
 Remove the motor as described in section 14.9.
 Remove the low water pressure sensor refer to section 14.11.
 Remove the secondary heat exchanger as described in section 14.12.
 Refer to diagram 14.7.
 Remove the expansion vessel pipe by removing the clip on the pump body. (clip at the rear, see diagram 14.8).
 Remove the pressure gauge connection and electrical connection from the R.H.hydroblock.
 Disconnect the union nuts (pressure safety relief valve and pump outlet).
 Refer to diagram 14.9.
 Remove the fixing screws from the pump and R.H.hydroblock at the bottom of the boiler.
 Remove the pump assembly.
 Refer to diagram 14.10.
 Remove the pump body, automatic air vent and brass union connector from the R.H. hydraulic assembly by releasing the clips. Fit these to the replacement pump body.
 Fit the replacement pump body and associated parts in reverse order ensuring that all sealing washers are sound and fitted correctly and the polarity of the electrical connections are correct.
 Open the isolating valves on the low and return connections, refill, vent and re-pressurise the system ensuring all joints are sound.

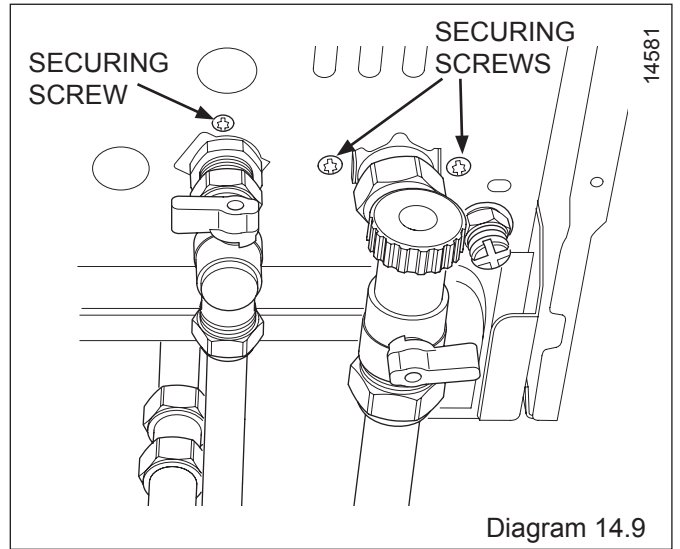

Diagram 14.9

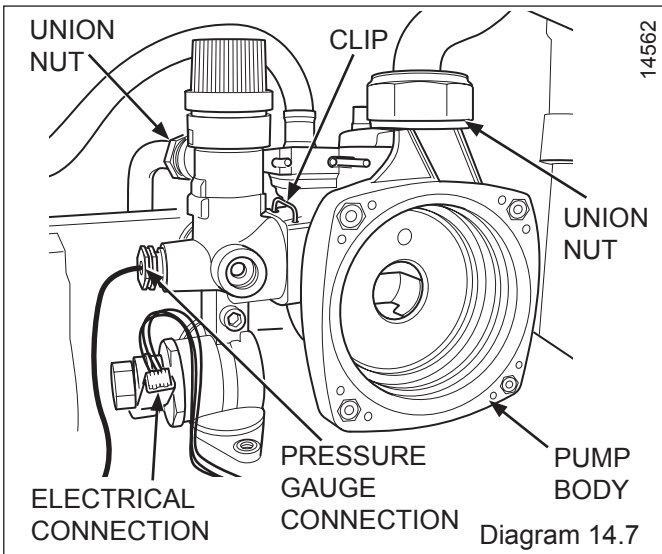

Diagram 14.7

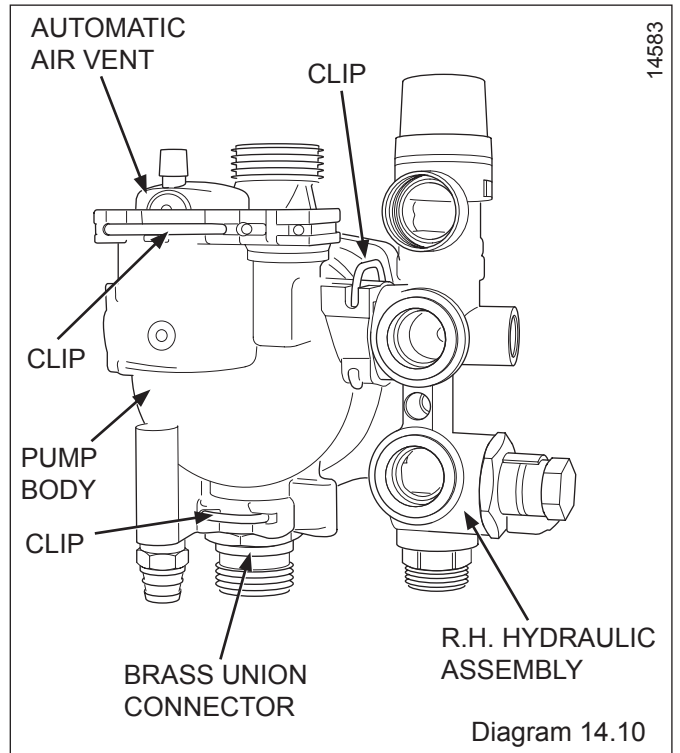

Diagram 14.10

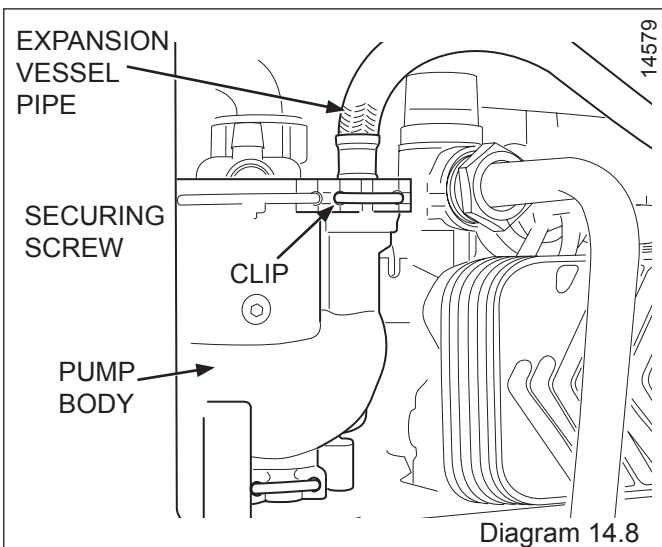
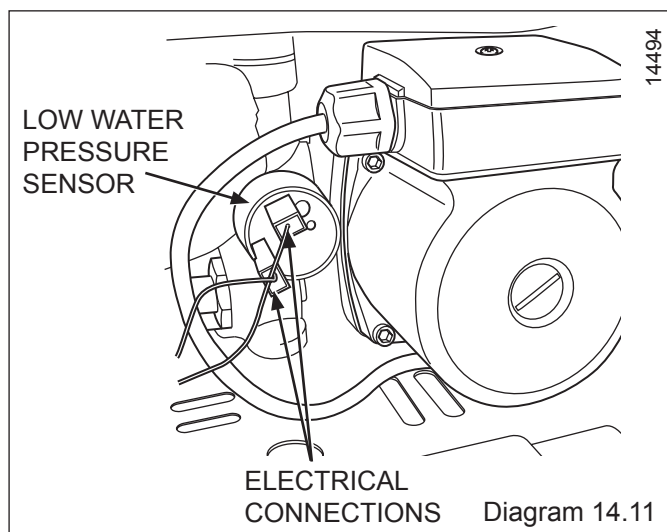

Diagram 14.8

14 Replacement of parts

14.11 low water pressure sensor

For access, refer to section 14.1.
 Drain the boiler circuit, refer to section 14.2.
 Locate the low water pressure sensor at the front right hand side of the boiler and remove the electrical sensors connections, see diagram 14.11.
 Remove the low water pressure sensor by turning it in an anticlockwise direction.
 Fit the replacement sensor in reverse order of removal ensuring all washers are fitted.
 Replace damaged washers as necessary.
 Open the isolating valves on the flow and return connections, refill, vent and re-pressurise the system ensuring all joints are sound.



14.12 Secondary heat exchanger

For access, refer to section 14.1.
 Drain the boiler circuit, refer to section 14.2.
 Remove the two screws which connect the heat exchanger to the L.H. / R.H. hydroblocks, see diagram 14.12.
 Remove the heat exchanger from the gap on the left hand side.
 Fit the new heat exchanger checking that the plate numbers are the same and reassemble in reverse order ensuring all washers are fitted or replaced as required.
 Open the isolating valves on the flow and return connections, refill, vent and re-pressurise the system ensuring all joints are sound.

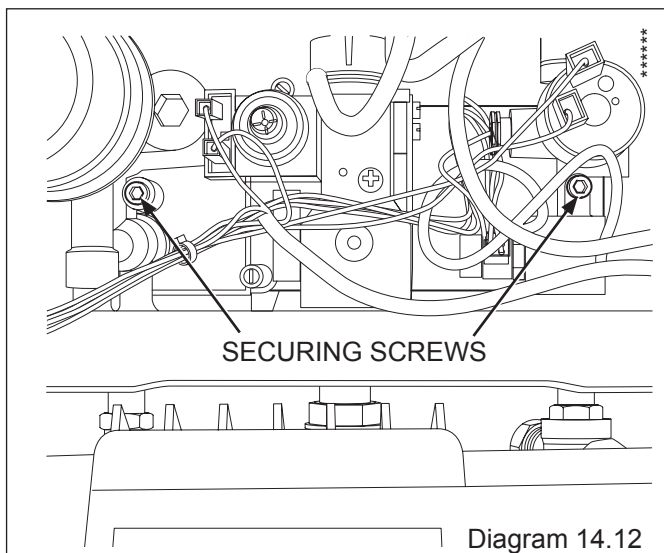

14.13 Primary Heat Exchanger

For access, refer to section 14.1.
 Drain the boiler circuit, refer to section 14.2.
 Refer to diagram 14.13.
 Remove the pipe clips on the pipes of primary heat exchanger.
 Remove the CH temperature sensor on the return pipe.
 Remove the pump and three way valve connection pipes.
 Release the pipe connections, retaining the washers for re-assembly.
 Remove the combustion chamber cover, see section 12.1.
 Carefully remove the heat exchanger by pulling forward taking care not to damage the insulation.
 Fit the new heat exchanger and reassemble the boiler in reverse order ensuring all the washers are fitted, or replaced as required.
 Open the isolating valves on flow and return connections, refill, vent and re-pressurise system ensuring the all joints are sound.

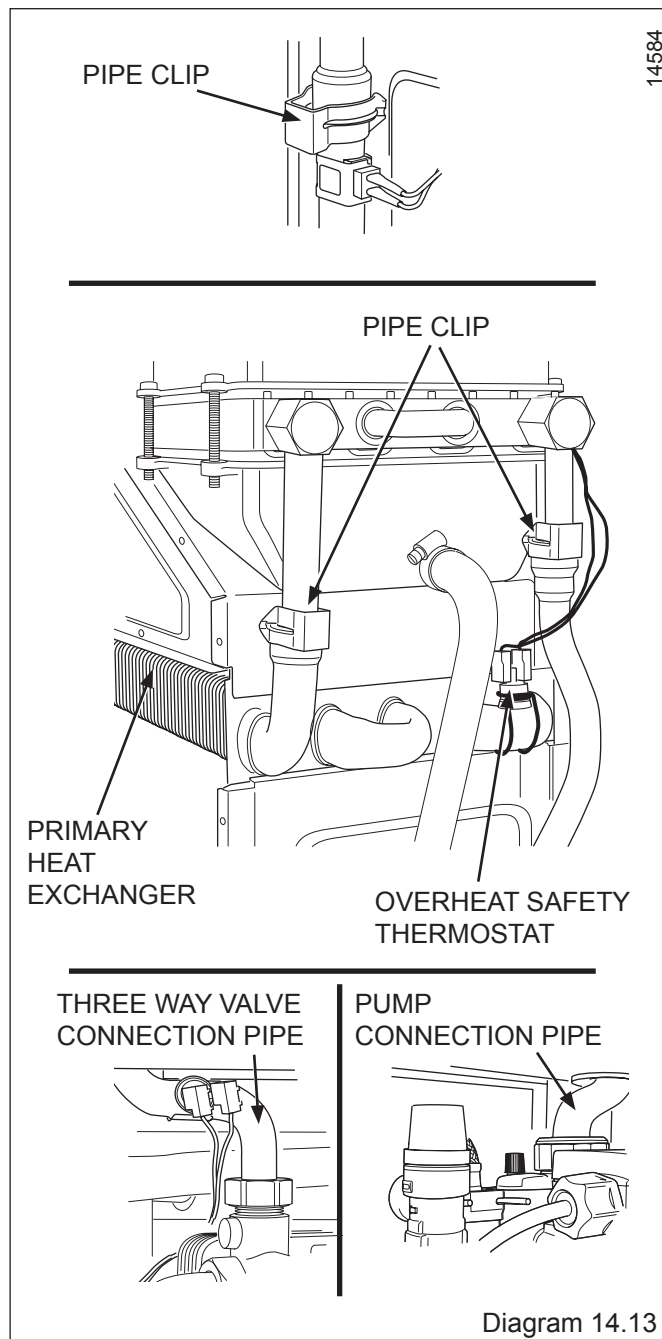

14 Replacement of parts

14.14 Gas valve

For access, refer to section 14.0.
Ensure that gas supply to boiler is turned off.
Refer to diagrams 14.14 and 14.15.
Disconnect the electrical connections to the modulating coil.
Remove the screw to disconnect the gas valve electrical plug.
Release the connections from gas valve and manifold inlet,
Remove the sensing tube.
Retaining the washers for use on reassembly.
Release the main gas connection between the gas valve supply pipe and gas inlet isolation valve, retaining the washer for use on reassembly, see diagram 14.15.
Remove the gas valve's two securing screws and washers from the underside of the boiler, see diagram 14.17.
Rotate the gas pipe and withdraw gas valve assembly.
Refit in reverse order to removal, the polarity of the wires to the modulating coil is not important.
Check gas soundness and correct boiler operation
Following replacement the maximum and minimum settings for natural gas must be checked to ensure they are 12.5 mbar / 2.5 mbar for the Betacom 24 and 14 mbar / 2.3 mbar for Betacom 30 respectively.
Check the gas valve settings and re-calibrated by the following method if required:

Minimum setting

Remove the sensing tube from the gas valve.
Remove one lead from the modulating gas valve coil, see diagram 14.15.
Refer to diagram 14.16.
Connect a suitable pressure gauge to the pressure outlet of the gas valve.
Turn the boiler's function switch to the 'Winter' position. (Heating and Hot Water), see diagram 11.4
Turn the central heating temperature control to maximum setting.
Remove the protective cover from the gas valve adjuster.
Turn the inner screw using a screwdriver, clockwise: to increase the pressure setting, anticlockwise: to decrease the pressure setting.
After correct adjustment see, 'Boiler specification section' page 8, re-connect the electrical connector and protective cover and replace the combustion cover to the boiler.

Maximum setting

Remove the sensing tube from the gas valve, see diagram 14.14.
Remove the protective cover from the gas valve adjuster.
Push the ball inside the modulating gas valve coil using a sharp pointed tool.
Turn the nut with a 10mm spanner (keeping the ball in without any rotation) clockwise: to increase the pressure setting, anticlockwise: to decrease the pressure setting.
After correct adjustment see, "Boiler specification" section, page 8.
Finally, replace the sensing tube to the gas valve.

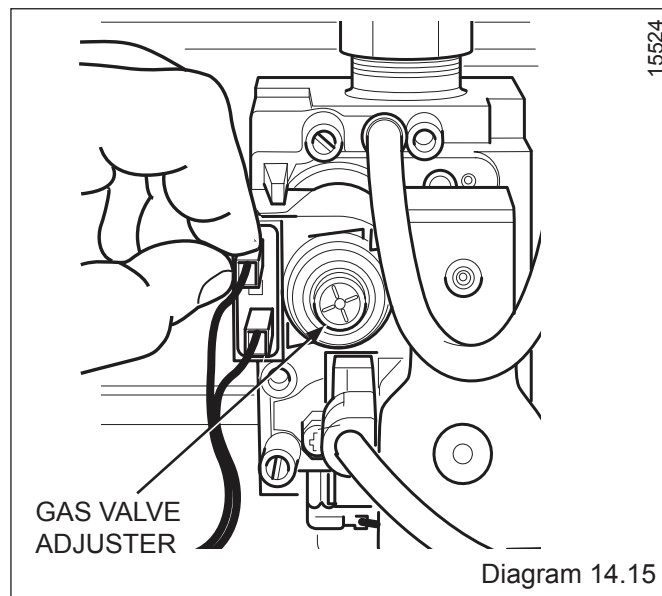
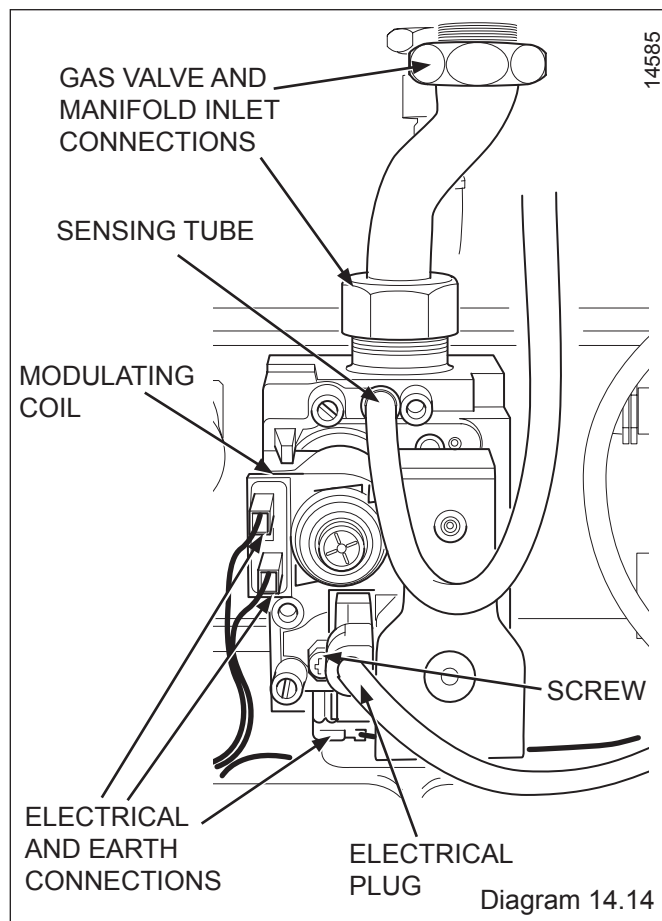

14 Replacement of parts

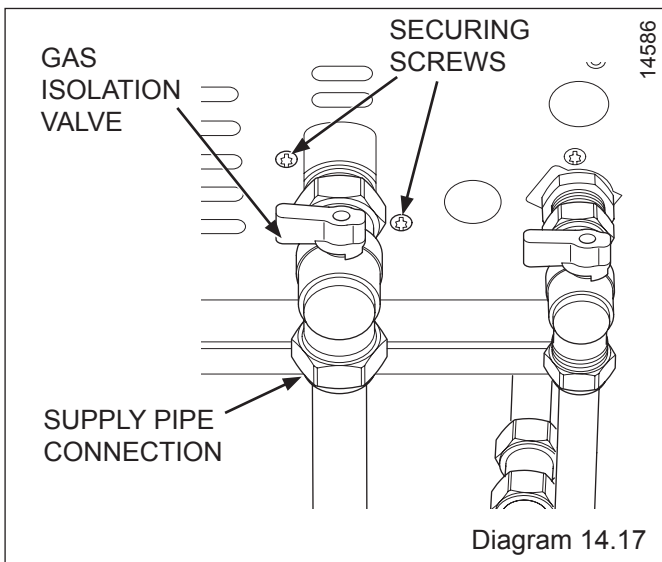
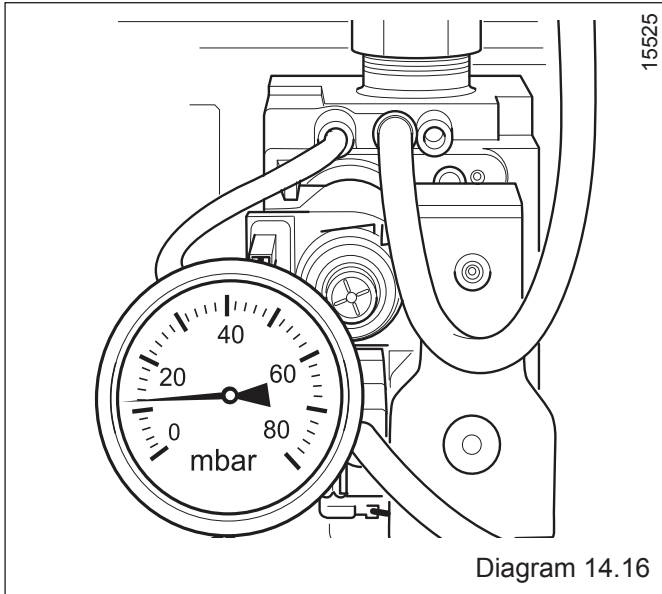

Checking the gas rate

The boiler is fitted with a fully modulating automatic gas valve. With all other gas appliances turned off measure the gas rate at the gas meter. Check that the gas rate is as stated in the table below:

Appliance	Maximum net heat input in kW	Gas rate
		Natural gas in (m ³ / h) nominal
Betacom 24c	25,7	2,72
Betacom 30c	28,5	3,02

Checking the combustion products

While adjusting the burner pressure at maximum and minimum, combustion products can be checked according to the table below:

Appliance	Combustion Products					
	CO ₂ (Vol - %)				CO (ppm)	
	Natural gas tolerance		Propane tolerance		Natural gas tolerance	Propane tolerance
	Max	Min	Max	Min		
Betacom 24c	8.60 ± 0.5	3.85 ± 0.5	9.60 ± 0.5	4.40 ± 0.5	< 400	< 400
Betacom 30c	8.10 ± 0.5	2.90 ± 0.5	9.30 ± 0.5	3.35 ± 0.5	< 400	< 400

14 Replacement of parts

14.15 Expansion vessel

For access, refer to section 14.1.
 Drain the boiler circuit, refer to section 14.2.
 Refer to diagram 14.16.
 Disconnect the flexible pipe coupling on expansion vessel.
 Release and remove the nut securing the expansion vessel to the boiler.
 Remove the side panels.
 Remove the air pressure switch, refer to section 14.6.
 Remove the flue if required.
 Lift the vessel out of boiler from the gap over the chassis and fit the replacement vessel to the boiler in reverse order to removal, ensuring that sealing washer is fitted to pipe connection before tightening, replace the washer if necessary.
 Using a pressure gauge, ensure that expansion vessel charge pressure is 0.5bar (7.5psi)
 Open the isolating valves on the flow and return connections, refill, vent and pressurise the boiler ensuring all joints are sound.

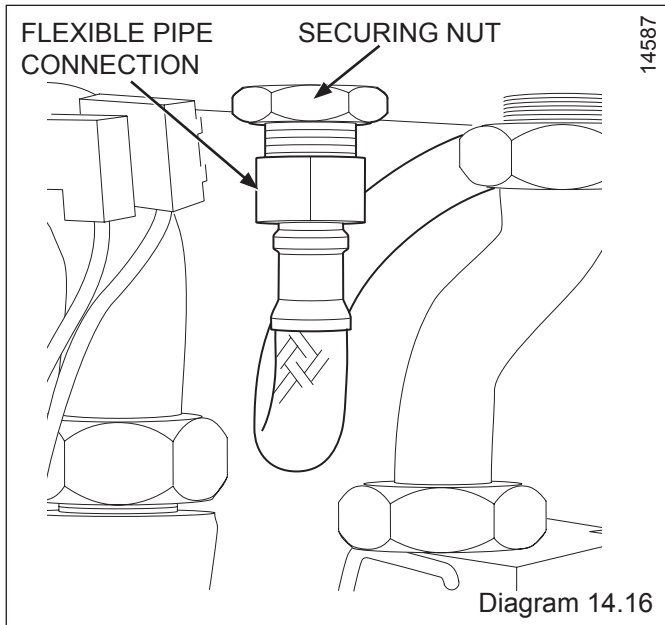

14.16 Overheat safety thermostats

For access, refer to section 14.1.
 Remove the front panel, combustion chamber cover and right side panel.
 Refer to diagram 14.17.
 Locate the overheat safety thermostat at the front left hand side of the boiler and on the right hand side of the primary heat exchanger.
 Disconnect the electrical connections from the thermostat.
 Unclip the thermostat from the pipe.
 Fit the replacement thermostat in reverse order of removal.

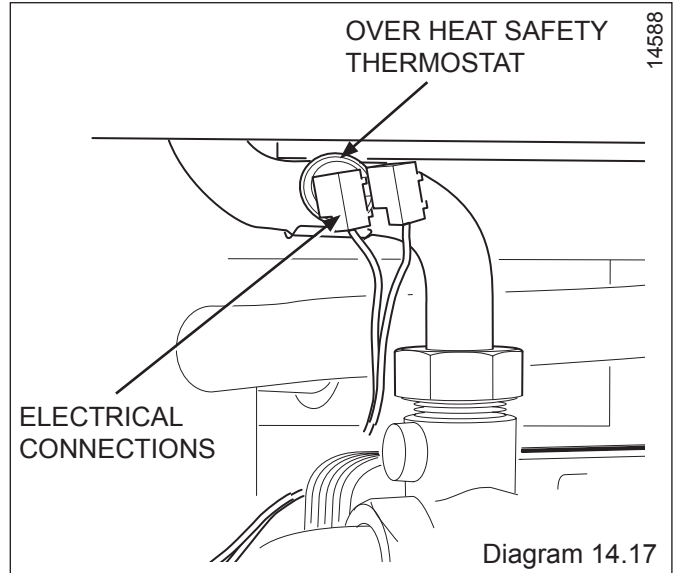

14.17 Pressure safety relief valve

For access, refer to section 14.1.
 Drain the boiler circuit, refer to section 14.2.
 Refer to diagram 14.18.
 Disconnect the discharge pipe on the outlet of the safety relief valve.
 Unscrew to remove the safety relief valve from the R.H. hydraulic block and retain the o-ring for use on reassembly, replace as necessary.
 Fit the replacement safety relief valve in reverse order to removal and refill, vent and pressurise boiler ensuring all joints are sound.

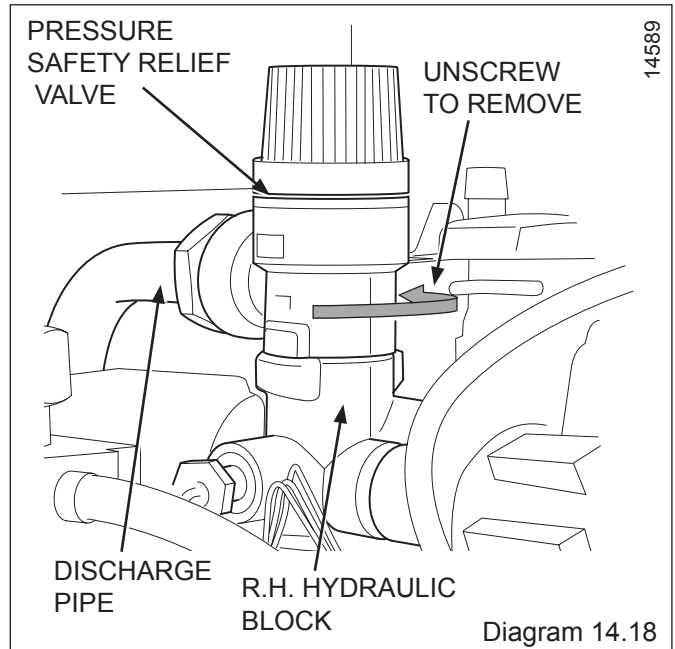

14 Replacement of parts

14.18 R.H. and L.H. Hydroblock

For access, refer to section 14.1.
Drain the boiler circuit, refer to section 14.2.
Refer to diagram 14.12.
Remove the secondary heat exchanger, see section 14.12.
Remove the pump assembly, see section 14.9. and 14.10.
Remove the section of the hydroblock from the pump by releasing the clip.
Release the heat exchanger outlet pipe nut and rotate the pipe for easy removal of the left section of the hydroblock.
Disconnect the three way valve motor, electrical connection and remove the motor by releasing the clip, see section 14.21.
Release the nut connecting the CH outlet connection to the hydroblock.
Disconnect the DHW sensor, see section 14.3.
Remove the screw securing the left part of the hydroblock to the combination boiler.
Fit the replacement hydroblock parts in reverse order to removal ensuring all seals are correctly located and replaced if necessary.
Open the isolating valves on the flow and return connections, refill, vent and pressurise boiler ensuring all joints are sound.

14.19 Filter

For access, refer to section 14.1.
Drain the boiler circuit, refer to section 14.2.
Refer to section 12.5. to remove.
Remove the filter in the inlet to the hydroblock.
Clean or fit a replacement filter.
Fit the components in reverse order of removal, ensuring all seals are correctly located and replaced if damaged.
Open the isolating valves on the flow and return connections, refill, vent and pressurise the boiler ensuring all joints are sound.

14.20 Flow sensor

For access, refer to section 14.1.
Refer to diagram 14.19.
Remove the flow sensor using a pair of pliers.
Fit a replacement sensor in reverse order to removal.

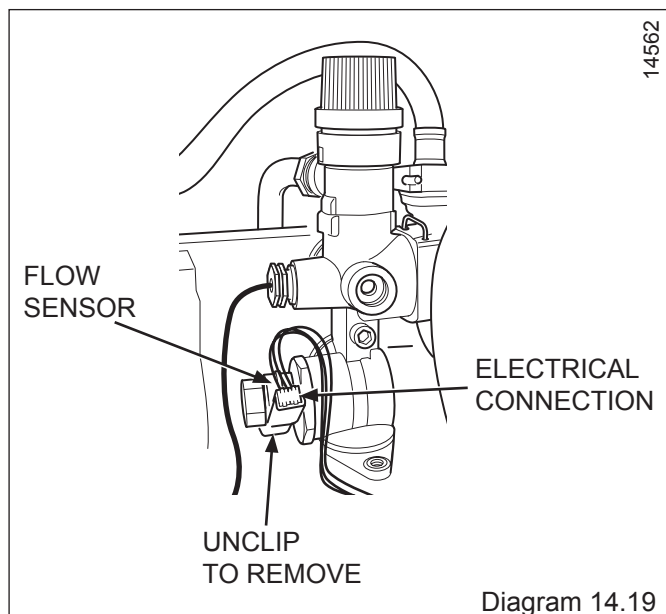

14.21 Three way valve motor

For access, refer to section 14.1.
Refer to diagram 14.20.
Ensure that the electric supply to the boiler is switched OFF.
Remove the electrical connection to the three way valve motor.
Remove the clips connecting the valve to L.H. hydroblock.
Fit the replacement valve in reverse order ensuring the valve is fitted properly.

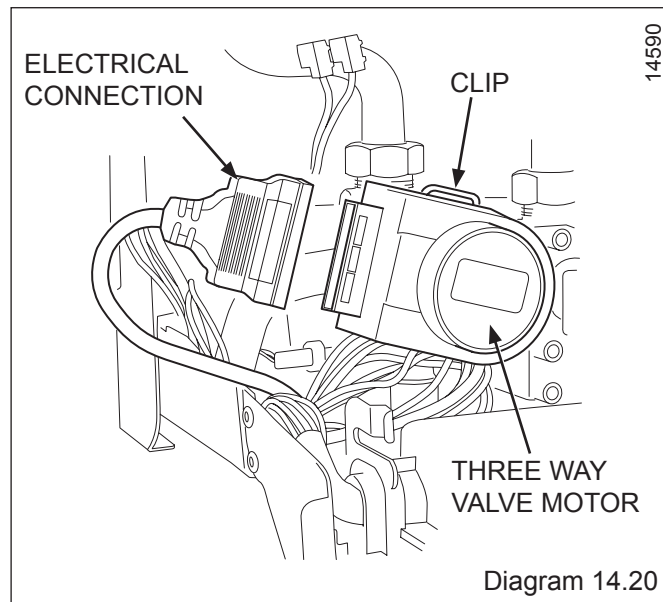

15 Spare parts

15.1 Spare Parts

When ordering spare parts, contact Glow-worm's own service organisation using the telephone number on the inside front cover of this booklet. Please quote the name of the appliance and serial number, to be found on the data label. If ordering from British Gas also quote the G.C. number of the part.

No.	Description	Model	Part No.
1	Fan		0020061578
2	Primary heat exchanger	24c	0020061589
3	Primary heat exchanger	30c	0020061590
4	Air pressure switch		0020064058
5	Ignition electrode (right)		0020051571
6	Ignition electrode (left)		0020061572
7	Flame sense (ionisation) electrode		0020061573
8	Safety valve		0020061610
9	CH NTC sensor		0020061581
10	O/h safety thermostat (reset)		0020061584
11	DHW sensor		0020061613
12	Limit thermostat		0020061592
13	Water flow sensor		0020061608
14	Low water pressure switch		0020061607
15	Injector	24c	0020061567

No.	Description	Model	Part No.
16	Injector	30c	0020061568
17	Diverter motor		0020061621
18	Burner	24c	0020061564
19	Burner	30c	0020061565
20	Secondary heat exchanger	24c	0020061614
21	Secondary heat exchanger	30c	0020061615
22	Pump		0020061598
23	Interface board		0020061647
24	Timer clock		0020061649
25	Water pressure gauge		0020061648
26	Gas valve		0020061602
27	Printed circuit board		0020061654
28	Burner bar (manifold)	24c	0020061569
29	Burner bar (manifold)	30c	0020061570

15 Spare parts

14595

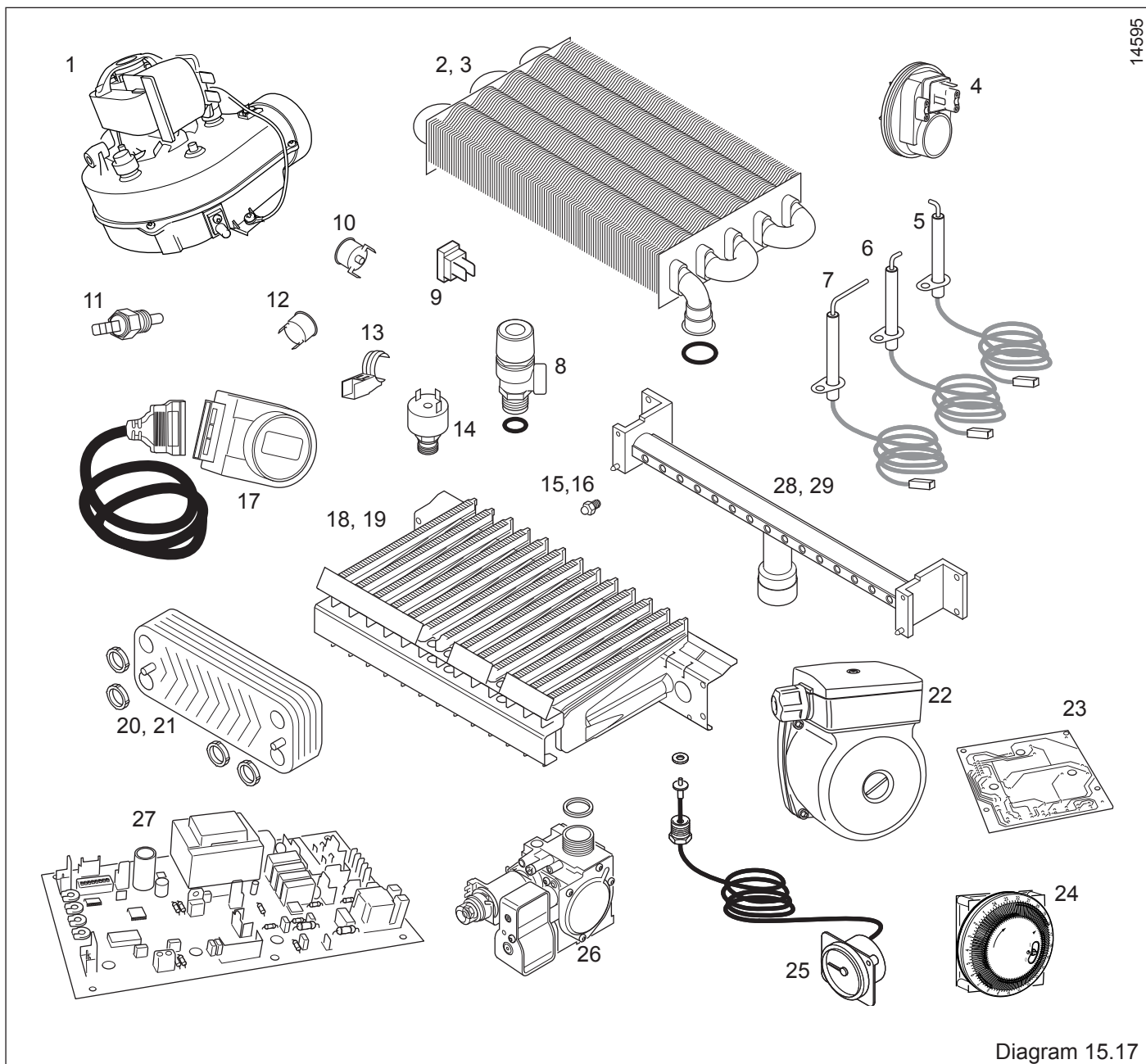

Diagram 15.17

16 Manual Handling

IMPORTANT. With regards to the Manual Handling Operations, 1992 Regulations, the following lift operation exceeds the recommended weight for a one man lift.

General recommendations when handling

Clear the route before attempting the lift.

Ensure safe lifting techniques are used – keep back straight – bend using legs. Keep load as close to body as possible. Do not twist – reposition feet instead. If 2 persons performing lift, ensure co-ordinated movements during lift. Avoid upper body/top heavy bending - do not lean forward/sideways. Recommend wear suitable cut resistant gloves with good grip to protect against sharp edges and ensure good grip. Always use assistance if required.

Removal of carton from delivery van

Recommend 2 person lift or 1 person with use of sack truck. If 1 person is performing lift, straddle the load, tilt and place carton into position on truck. Recommend secure appliance onto truck with suitable straps. Ensure safe lifting techniques are used – keep back straight – bend using legs. Keep load as close to body as possible. If 2 persons performing lift, ensure co-ordinated movements during lift. Always use assistance if required.

Carriage of carton from point of delivery to point of installation – ground floor.

Recommend 2 person lift or 1 person with use of sack truck. If 1 person is performing lift, straddle the load, tilt and place carton into position on truck. Recommend secure appliance onto truck with suitable straps. Ensure safe lifting techniques are used – keep back straight – bend using legs. Keep load as close to body as possible. If 2 persons performing lift, ensure co-ordinated movements during lift. Clear the route before attempting the lift. If removing boiler from truck straddle the load and tilt forwards to facilitate secure grip. Ensure safe lifting techniques are used – keep back straight – bend using legs. Do not twist – reposition feet instead. Take care to avoid trip hazards, slippery or wet surfaces and when climbing steps and stairs. Always use assistance if required.

Carriage of carton from point of delivery to point of installation – first or higher floor, cellar.

Recommend 2-person lift or 1 person with use of sack truck. If 1 person is performing lift, straddle the load, tilt and place carton into position on truck. Recommend secure appliance onto truck with suitable straps. Ensure safe lifting techniques are used – keep back straight – bend using legs. Keep load as close to body as possible. If 2 persons performing lift, ensure co-ordinated movements during lift. Avoid upper body/top heavy bending - do not lean forward/sideways. Clear the route before attempting the lift. If removing boiler from truck straddle the load and tilt forwards to facilitate secure grip. Ensure safe lifting techniques are used – keep back straight – bend using legs. Do not twist – reposition feet instead. Take care to avoid trip hazards, slippery or wet surfaces and when climbing steps and stairs. Always use assistance if required.

Carriage of carton from point of delivery to point of installation – roofspace.

Recommend 2-person lift. Ensure co-ordinated movements during lift. Avoid upper body/top heavy bending - do not lean forward/sideways. Clear the route before attempting the lift. Take care to avoid trip hazards, slippery or wet surfaces and when climbing steps and stairs. When transferring appliance into roofspace, recommend 1 person to be in roofspace to receive the appliance and other person to be below to pass up and support appliance. Ensure safe lifting techniques are used – keep back straight – bend using legs. Keep load as close to body as possible. Always use assistance if required. It is assumed safe access, flooring and adequate lighting are provided in the roof space. It is recommended a risk assessment of the roof space area be carried out before moving the appliance into the area to take into account access, stability of flooring, lighting and other factors, and appropriate measures taken.

Unpacking of appliance from carton.

Recommend 2 persons unpack appliance from carton. Always keep working area clear. Recommend cut base end of carton and open carton flaps, then tilt boiler forwards from its side onto its base and remove carton by sliding up over the boiler. Ensure safe lifting techniques are used – keep back straight – bend using legs. Keep load as close to body as possible. Always use assistance if required. Dispose

of packaging in a responsible manner. Recommend wear suitable cut resistant gloves with good grip to protect against sharp edges and ensure good grip when handling appliance outside packaging.

Positioning of Appliance for Final Installation – no obstructions.

This appliance is deemed to be a one person lift when removed from the carton. Fit bracket securely onto wall before lifting appliance into position. Obtain firm grip on front and sides of appliance, lift upwards, ensure stable balance achieved and lift upwards to position in place on bracket. Ensure safe lifting techniques are used – keep back straight – bend using legs - when lifting load from floor level. Do not twist – reposition feet instead. Keep boiler as close as possible to body throughout lift to minimise strain on back. Ensure co-ordinated movements to ensure equal spread of weight of load. Always use assistance if required. Recommend wear suitable cut resistant gloves with good grip to protect against sharp edges and ensure good grip when handling appliance.

Positioning of Appliance for Final Installation – above worktop, foreseeable obstructions etc.

This appliance is deemed to be a one person lift when removed from the carton. Fit bracket securely onto wall before lifting appliance into position. Obtain firm grip on front and sides of appliance, lift upwards, onto worktop if practicable. Ensure stable balance achieved and lift upwards to position in place on bracket. If 2 persons positioning onto bracket obtain firm grip at front and sides/base of boiler. Ensure co-ordinated movements during 2 person lifts to ensure equal spread of weight of load. Ensure safe lifting techniques are used – keep back straight – bend using legs - when lifting load from floor level. Do not twist – reposition feet instead. Keep boiler as close as possible to body throughout lift to minimise strain on back. Avoid upper body/top heavy bending - do not lean forward/sideways. Always use assistance if required. Recommend wear suitable cut resistant gloves with good grip to protect against sharp edges and ensure good grip when handling appliance.

Positioning of Appliance for Final Installation – within compartment etc. restricting installation.

This appliance is deemed to be a one person lift when removed from the carton. Fit bracket securely onto wall before lifting appliance into position. Obtain firm grip on front and sides of appliance, lift upwards, onto worktop if practicable. Ensure stable balance achieved and lift upwards to drop into place onto bracket. If 2 persons positioning onto bracket obtain firm grip at front and sides/base of boiler. Ensure co-ordinated movements during 2 person lifts to ensure equal spread of weight of load. If 1 person positioning onto bracket recommend obtain firm grip supporting base of boiler. Ensure safe lifting techniques are used – keep back straight – bend using legs - when lifting load from floor level. Do not twist – reposition feet instead. Keep boiler as close as possible to body throughout lift to minimise strain on back. Always use assistance if required. Recommend wear suitable cut resistant gloves with good grip to protect against sharp edges and ensure good grip when handling appliance.

Positioning of Appliance for Final Installation – in roof space restricting installation.

This appliance is deemed to be a one person lift when removed from the carton. Obtain firm grip on front and sides of appliance, lift upwards, ensure stable balance achieved and lift upwards to drop into place onto bracket. If 2 persons positioning onto bracket obtain firm grip at front and sides/base of boiler. Ensure co-ordinated movements during 2 person lifts to ensure equal spread of weight of load. If 1 person positioning onto bracket recommend obtain firm grip supporting base of boiler. Ensure safe lifting techniques are used - keep back straight – bend using legs - when lifting load from floor level. Do not twist – reposition feet instead. Keep boiler as close as possible to body throughout lift to minimise strain on back. Always use assistance if required. Recommend wear suitable cut resistant gloves with good grip to protect against sharp edges and ensure good grip when handling appliance. It is recommended a risk assessment of the roof space area be carried out before moving the appliance into the area to take into account access, stability of flooring, lighting and other factors, and appropriate measures taken.

17 Declaration of conformity



EC declaration of conformity

Name and Address of the manufacturer: Glow-worm
Nottingham Road
Belper
Derbyshire DE56 1JQ

Identification of product: Gas condensing boiler

Appliance type: BETACOM 24C
BETACOM 30C
BETACOM 24C S
BETACOM 30C S

The appliance types satisfy the essential requirements of the relevant directives and Standards:

90/396/EEC including amendments
"Directive on the approximation of the law of the member states relating to appliances burning gaseous fuels"

Designed and built to CE-type examination certificate:

PIN no: **CE 0051BP2727**
CE 0051BP2728DR

92/42/EEC including amendments
"Directive of efficiency relating to boiler burning gaseous fuels"

Designed and built according to European Standards:

2006/95/EEC including amendments
"Directive on the harmonization of the laws of Member States relating to electrical equipment designed for use within certain voltage limits"

EN 483
EN 656
EN 677
EN 60335-1
EN 60529
EN 50165
EN 55014

2004/108/EEC including amendments
"Directive on the approximation of the law of the member states relating to electromagnetic compatibility"

Any change to the appliance and/or any use not according to the instructions will lead to the invalidation of this Declaration of Conformity

Belper, 13.05.2008
(place, date)

UK Marketing Director
John Collins

Certification Group Manager
Albrecht Nunn

Because of our constant endeavour for improvement, details may vary slightly from those shown in these instructions.

Glow-worm, Nottingham Road, Belper, Derbyshire. DE56 1JT