

Flexicom

Installation and Servicing

12hx

G.C. No. 41-315-28

15hx

G.C. No. 41-315-29

18hx

G.C. No. 41-315-42

24hx

G.C. No. 41-315-61

30hx

G.C. No. 41-315-67

35hx

G.C. No. 41-315-68

**High Efficiency
Condensing
Boilers**

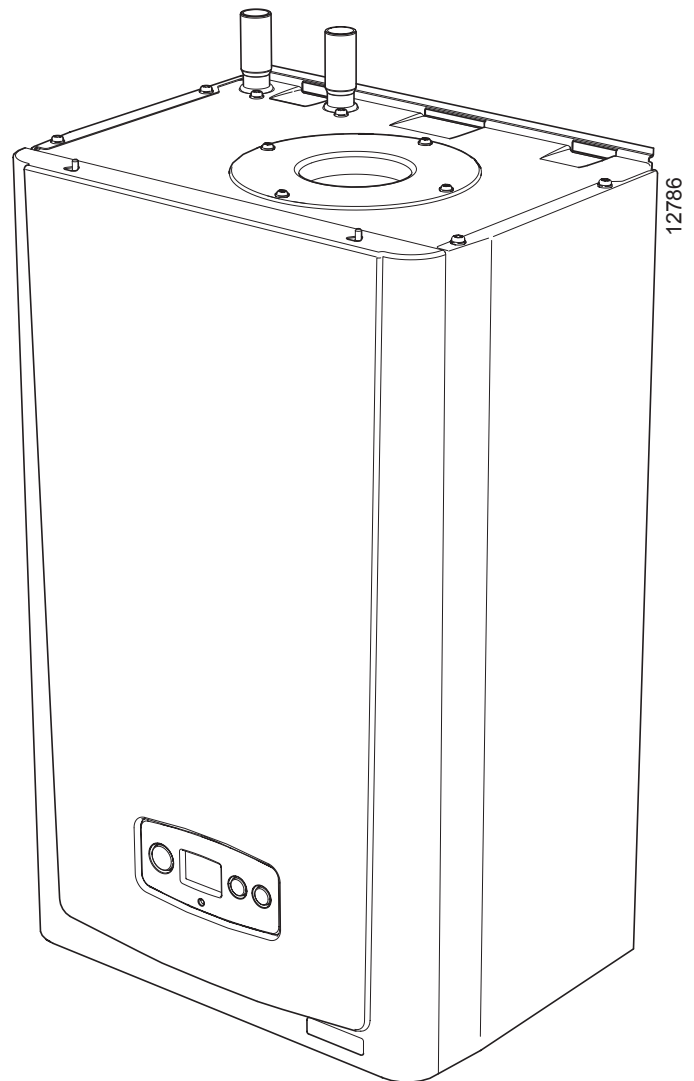

Guarantee Registration

Thank you for installing a new Glow-worm appliance in your home.

Glow-worm appliances are manufactured to the very highest standard so we are pleased to offer our customers a Comprehensive Guarantee.

This product is guaranteed for 24 months from the date of installation or 30 months from the date of manufacture, whichever is the shorter, for parts and labour.

The second year of the parts guarantee, from the beginning of the 13th month onwards after installation or manufacture, is conditional upon the boiler having been serviced by a **competent person** approved at the time by the Health and Safety Executive.

in accordance with the manufacturer's recommendations. We strongly recommend regular servicing of your gas appliance, but where the condition is not met, any chargeable spare parts or components issued within the applicable guarantee period still benefit from a 12 month warranty from the date of issue by the manufacturer.

We recommend you complete and return as soon as possible your guarantee registration card. If your guarantee registration card is missing you can obtain a copy or record your registration by telephoning the Glow-worm Customer Service number 01773 828100.

Customer Service:

01773 828100

Technical Helpline:

01773 828300

General and Sales enquiries:

Tel. 01773 824639

Fax: 01773 820569

To register your Glow-worm appliance call:

0800 0732142

Benchmark places responsibilities on both manufacturers and installers. The purpose is to ensure that customers are provided with the correct equipment for their needs, that it is installed, commissioned and serviced in accordance with the manufacturer's instructions by competent persons and that it meets the requirements of the appropriate Building Regulations. The Benchmark Checklist can be used to demonstrate compliance with Building Regulations and should be provided to the customer for future reference.

Installers are required to carry out installation, commissioning and servicing work in accordance with the Benchmark Code of Practice which is available from the Heating and Hotwater Industry Council who manage and promote the Scheme.

Visit www.centralheating.co.uk for more information.



These instructions consist of, Installation, Servicing, Fault Finding, Replacement of Parts and Spares. The instructions are an integral part of the appliance and must, to comply with the current issue of the Gas Safety (Installation and Use) Regulations, be handed to the user on completion of the installation.

CONTENTS	DESCRIPTION	SECTION	PAGE
INTRODUCTION	Warnings		4
	Important Information		4
	Statutory Requirements		5
	Boiler Design		6
	Safety Devices		6
	Servicing, Maintenance and Spare Parts		6
INSTALLATION	Boiler Specification	1	7
	Boiler Dimensions and Hydraulic Schematic	2	8
	Boiler Location, Clearances and Ventilation	3	9
	Flue Options and Terminal Clearances	4	10
	Water Systems	5	12
	• General	5	12
	• Open Vented	5	13
	• Sealed Systems	5	14
	Installation Preparation	6	16
	Boiler Fixing	7	17
	Gas/Water and Appliance Connection	8	18
	Condensate Connections	9	18
	Flue Length Preparation and Installation	10	20
	Electrical Connection	11	37
Commissioning	12	38	
MAINTENANCE	Servicing	13	41
	Fault Finding	14	46
	Replacement of Parts	15	52
	Spare Parts	16	57
	Manual Handling	17	58
	Declaration of Conformity	18	59

WARNINGS

Gas Leak or Fault

Turn off the gas emergency control valve immediately. Eliminate all sources of ignition, i.e. smoking, blowlamps, hot air guns etc. Do not operate electrical lights or switches either on or off. Open all doors and windows, ventilate the area.

Sheet Metal Parts

This boiler contains metal parts (components) and care should be taken when handling and cleaning, with particular regard to edges.

Sealed Components

Under no circumstances must the User interfere with or adjust sealed parts.

Important Information

Gas Category

This boiler is for use only on G20 natural gas.

Gas Safety (Installation and Use) Regulations

In your own interests and that of safety, it is the Law that ALL gas appliances are installed by a **competent person** approved at the time by the Health and Safety Executive in accordance with the current issue of these regulations.

Control of Substances Hazardous to Health

Under Section 6 of The Health and Safety at Work Act 1974, we are required to provide information on substances hazardous to health.

The adhesives and sealants used in this appliance are cured and give no known hazard in this state.

Manual Handling

With regards to the "Manual Handling Operations, 1992 Regulations", the appliance exceeds the recommended weight for a one man lift, refer to section 17 for more information.

The handling of the boiler may involve lifting, pushing and pulling, the use of a sack truck may be required.

The following handling techniques and precautions should be considered:

- Grip the boiler at its base
- Be physically capable
- Use safety clothing where appropriate, e.g. gloves, safety footwear.

Ensure safe lifting techniques are used

- Keep back straight.
- Avoid twisting at the waist.
- Avoid upper body/top heavy bending.
- Always grip using the palm of the hand.
- Use designated hand holds.
- Keep load as close to body as possible.
- Always use assistance if required.

Electrical Supply

The boiler MUST be earthed.

All system components shall be of an approved type and all wiring to current I.E.E. wiring regulations.

External wiring must be correctly earthed, polarised and in accordance with the relevant standards.

In GB, this is BS 7671.

In IE, this is the current edition of ETCI rules.

The boiler MUST be connected to a permanent 230V ac, 50Hz supply.

Connection of the whole electrical system of the boiler, including any heating controls, to the electrical supply MUST be through one common isolator and must be fused 3 Amp maximum.

Isolation should be by a double pole switched fused spur box, with a minimum gap of 3mm for both poles. The fused spur box should be readily accessible and preferably adjacent to the appliance. It should be identified as to its use.

Alternatively connection can be made through an unswitched shuttered socket and 3A fused 3-pin plug both to the current issue of BS 1363, provided they are not used in a room containing a bath or shower.

Wiring to the boiler must be PVC 85°C insulated cable, not less than 0.75mm² (24/0.20mm).

Testing and Certification

This boiler is tested and certificated for safety and performance. It is, therefore, important that no alteration is made to the boiler, without permission, in writing, by Glow-worm.

Any alteration not approved by Glow-worm, could invalidate the certification, boiler warranty and may also infringe the current issue of the statutory requirements.

Statutory Requirements

CE Mark

This boiler meets the requirements of Statutory Instrument, No. 3083 The Boiler (Efficiency) Regulations, and therefore is deemed to meet the requirements of Directive 92/42/EEC on the efficiency requirements for new hot water boilers fired with liquid or gaseous fuels.

Type test for purposes of Regulation 5 certified by: Notified body 0087.

Product/production certified by: Notified body 0086.

The CE mark on this appliance shows compliance with:

1. Directive 90/396/EEC on the approximation of the laws of the Member States relating to appliances burning gaseous fuels.
2. Directive 73/23/EEC on the harmonisation of the Laws of the Member States relating to electrical equipment designed for use within certain voltage limits.
3. Directive 89/336/EEC on the approximation of the Laws of the Member States relating to electromagnetic compatibility.

IMPORTANT

Where no British Standards exists, materials and equipment should be fit for their purpose and of suitable quality and workmanship.

The installation of this boiler must be carried out by a **competent person** approved at the time by the Health and Safety Executive in accordance the rules in force in the countries of destination.

Manufacturer's instructions must not be taken as overriding statutory requirements.

Statutory Requirements

In GB, the installation of the boiler must comply with the requirements of the current issue of BS6798 and be carried out by a **competent person**, approved at the time by the Health and Safety Executive, as described in the following regulations:

The manufacturer's instructions supplied.

The Gas Safety (Installation and Use) Regulations.

The appropriate Buildings Regulations either The Building Regulations, The Building Regulations (Scotland), The Building Regulations (Northern Ireland).

The Water Supply (water fittings) Regulations 1999 and water byelaws 2000, Scotland.

The Health and Safety at Work Act, Control of Substances Hazardous to Health (COSHH).

The Current I.E.E. Wiring Regulations.

Where no specific instructions are given, reference should be made to the relevant British Standard Code of Practice.

In IE, the installation must be carried out by a **competent person** approved at the time by the Health and Safety Executive and installed in accordance with the current edition of I.S.813 "Domestic Gas Installations", the current Building Regulations and reference should be made to the current ETCI rules for Electrical Installation.

GB: the following Codes of Practice apply:

BS4814, BS6798, BS5440 Part 1 and 2, BS5546 Part 1, BS5449, BS6891, BS6700, BS7074 Part 1 and 2, BS7593, BS7671.

IE: I.S.813, BS5546, BS 5449, BS 7074, BS 7593.

NOTE: For further information, see the current issue of the Building Regulations, approved document L1 (in the UK) and the following current issues of:

- 1) Central heating system specification (CheSS) and
- 2) Controls for domestic central heating system and hot water. BRECSU.

Gas Supply

The gas installation must be in accordance with the relevant standards.

In GB, this is BS6891.

In IE, this is the current edition of I.S.813 "Domestic Gas Installations".

The supply from the governed meter must be of adequate size to provide a steady inlet working pressure of 20mbar (8in wg) at the boiler.

On completion, test the gas installation for tightness using the pressure drop method and suitable leak detection fluid, purge in accordance with the above standard.

Domestic Hot Water

All domestic hot water circuits, connections, fittings must be in accordance with the relevant standards and water supply regulations.

GB: Guidance G17 to G24 and recommendation R17 to R24 of the Water Regulations Guide.

IE: The current edition of I.S.813 "Domestic Gas Installations".

Heating System

In GB, it is necessary to comply with the Water Supply (Water Fittings) Regulations 1999 (for Scotland, the Water Byelaws 2000, Scotland).

To comply with the Water regulations your attention is drawn to: The Water Regulations guide published by the Water Regulations Advisory Service (WRAS) gives full details of the requirements.

In IE, the requirements given in the current edition of I.S.813 "Domestic Gas Installations" and the current Building Regulations must be followed.

Boiler Design

Boiler Design

These boilers are designed to provide central heating from a fully pumped open vented or sealed water system and domestic hot water using a fully indirect cylinder. Once the controls are set the boiler operates automatically.

Range Rating

The boilers are fully modulating for central heating, and it is therefore not necessary to range rate the boiler. However, if desired, it is possible to range rate the boiler between 10 and Max. output (according to the model), in 1kW increments, refer to section 12.

Condensate Drain

A plastic drain pipe must be fitted to allow discharge of condensate to a drain.

Condensate should, if possible, be discharged into the internal household draining system. If this is not practical, discharge can be made externally into the household drainage system or a purpose designed soak away, see section 8 for more details.

Plumbing from flue terminal

Like all condensing boilers this appliance will produce a plume of condensation from the flue terminal in cool weather. This is due to the high efficiency and hence low flue gas temperature of the boiler. This is normal and not an indication of a fault.

Safety Devices

Electrical Supply Failure

The boiler will not work without an electrical supply. Normal operation of the boiler should resume when the electrical supply is restored. Reset any external controls, to resume normal operation of the central heating.

If the boiler does not resume normal operation press the reset button. If the boiler does not resume normal operation after this call your Installation/Service company or Glow-worm service.

Overheating Safety

The boiler software is designed to recognise the potential for an overheat lockout and will shutdown before this happens. To restart the boiler, press the reset button on the controls fascia.

If the boiler fails to resume normal operation and all external controls are calling for heat, then call your Installation/Service company or Glow-worm service.

Frost protection

The appliance has a built in frost protection device that protects the boiler from freezing. With the gas and electric supplies ON and irrespective of any room thermostat setting, the frost protection device will operate the pump when the temperature of the boiler water falls below 8°C.

A timer is used so that the temperature can be checked periodically. After 10 minutes the pump will be stopped if the temperature is higher than 10°C or has already reached 35°C. The burner will activate if the boiler temperature does not reach 10°C after 30 minutes or at any time if the temperature drops to 5°C.

The burner will switch off when the temperature reaches 35°C.

Condensate Drain Blockage

As a safety feature the boiler will stop working if the condensate drain becomes blocked. During freezing conditions this may be due to the forming of ice in the condensate drain external to the house. Release an ice blockage by the use of warm cloths on the pipe. The boiler should then restart.

Servicing, Maintenance and Spare Parts

Servicing and Maintenance

To ensure the continued efficient and safe operation of the boiler it is recommended that it is checked and serviced as necessary at regular intervals. The frequency of servicing will depend upon the particular installation conditions and usage. If this appliance is installed in a rented property there is a duty of care imposed on the owner of the property by the current issue of the Gas Safety (Installation and Use) Regulations, Section 35.

Servicing/maintenance should be carried out by a **competent person** approved at the time by the Health and Safety Executive in accordance with the rules in force in the countries of destination.

To obtain service, please call your installer or Glow-worm's own service organisation using the telephone number on the inside front cover of this literature.

Spare Parts

Remember, when replacing a part on this appliance, use only spare parts that you can be assured conform to the safety and performance specification that we require. Do not use reconditioned or copy parts that have not been clearly authorised by Glow-worm.

If a part is required contact Glow-worm's own service organisation using the telephone number on the inside front cover of this booklet.

Please quote the name of the appliance, this information will be on the name badge on the front of the appliance.

If in doubt seek advice from the local gas company or Glow-worm's own service organisation using the telephone number on the inside front cover of this booklet.

1 Boiler Specification

14730

BOILER SPECIFICATION							
Lift weight		12hx to 30hx 25kg (55lb)		35hx 26.5kg (58.4lb)			
Total weight (installed)		12hx to 30hx 28kg (62lb)		35hx 29.5kg (65lb)			
Gas connection Ø O.D.		15mm. copper					
Heating Flow and Return connection Ø O.D.		22mm. copper					
Condensate connection Ø I.D.		21.5mm. plastic					
Electrical supply		230V~50Hz					
Electrical rating		60W fused 3A					
IP classification		IPX4D					
Internal fuse rating on main PCB		2A					
Gas supply (governed meter only) and cat.		G20 natural gas					
Gas Category		I2H natural gas					
Inlet gas working pressure		20mbar					
Burner % CO ₂ case on		9.3 nominal					
Burner % CO ₂ case off		9.3 nominal					
		12hx	15hx	18hx	24hx	30hx	35hx
Approximate max. gas rate after 10 mins. from cold	m ³ /h	1.28	1.60	1.93	2.58	3.26	3.8
	ft ³ /h	45	56.5	68.1	90.9	115	134
Approximate min. gas rate after 10 mins. from cold	m ³ /h	0.99	0.99	0.99	0.99	0.99	0.99
	ft ³ /h	35.1	35.1	35.1	35.1	35.1	35.1
Approximate gas rate at part load.		PLEASE REFER TO THE COMMISSIONING SECTION					
Heat input NETT Q = kW	max.	12.1	15.1	18.2	24.4	30.8	35.8
	min.	9.4	9.4	9.4	9.4	9.4	9.4
Heat output P = kW	max.	12	15	18	24	30	35.0
	min.	9.3	9.3	9.3	9.3	9.3	9.3
SEDBUK rating	Band A	90.7	90.5	90.4	90.3	90.3	90.0
Flue type (all models)		C13, C33, C43, C53					
NOx (all models)		Class 5					

Diagram 1.2

2 Boiler Dimensions and Hydraulic Schematic

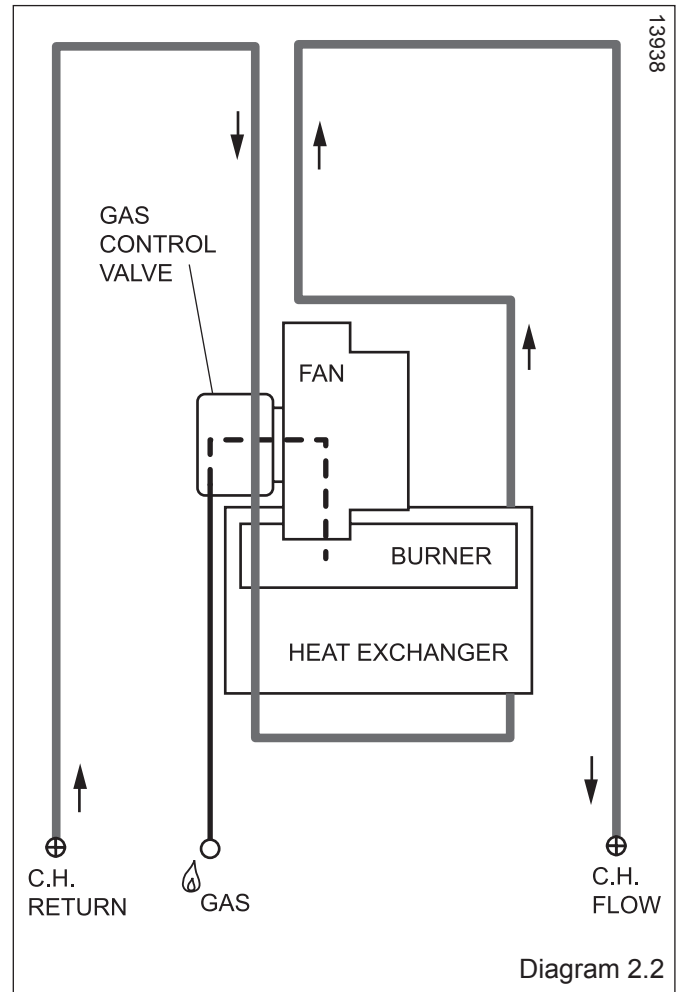
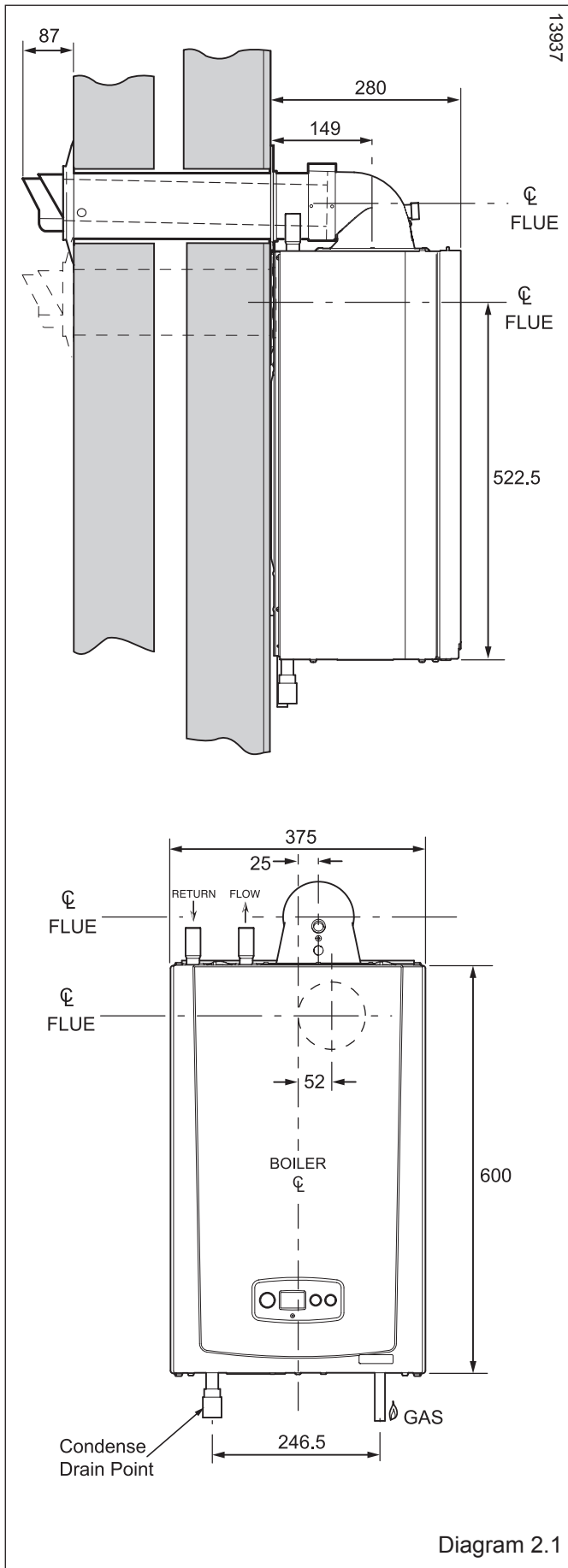

2.1 Boiler Dimensions and Hydraulic Schematic

All dimensions are given in millimetres (except as noted).

The general arrangement of the boiler is shown in diagram 2.1. and the hydraulic and gas schematic, diagram 2.2.

The data label is positioned on the front of the inner casing panel.

4 Flue Options and Terminal Clearances

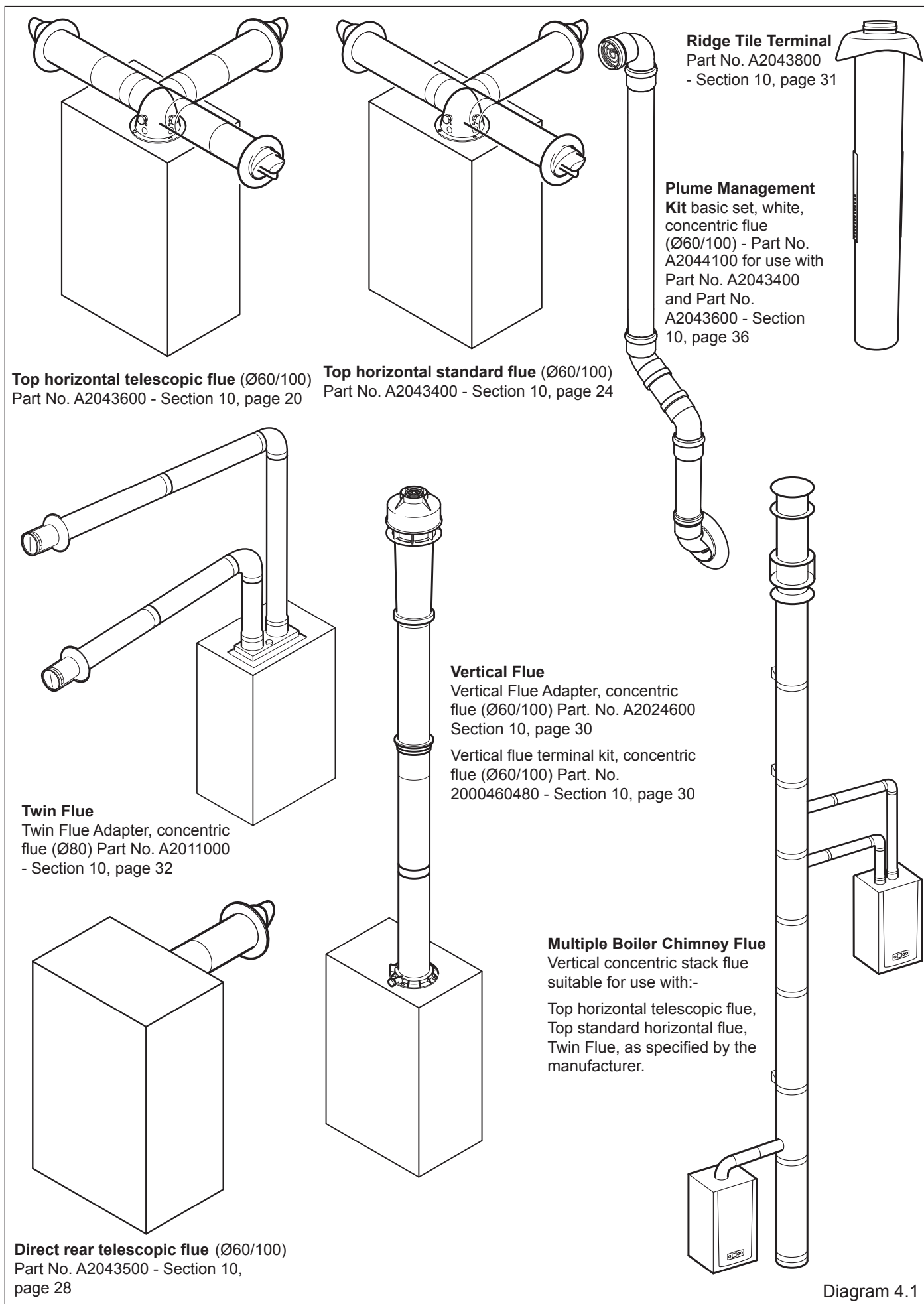
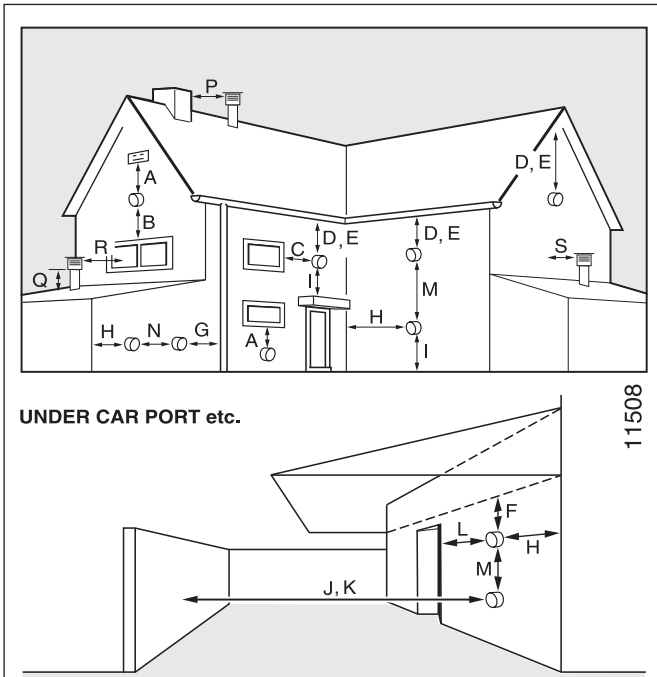

Diagram 4.1

4 Flue Options and Terminal Clearances



HORIZONTAL FLUES

A	DIRECTLY BELOW AN OPENING, AIR BRICK, OPENING WINDOWS	300
B	ABOVE AN OPENING, AIR BRICK, OPENING WINDOWS	300
C	HORIZONTALLY TO AN OPENING, AIR BRICK, OPENING WINDOWS	300
D	BELOW GUTTER, DRAIN/SOIL PIPE	25
E	BELOW EAVES	25
F	BELOW A BALCONY OR CAR PORT	25
G	FROM VERTICAL DRAIN PIPES AND SOIL PIPES	25
H	FROM INTERNAL/EXTERNAL CORNERS	25
H*	TO A BOUNDARY ALONGSIDE THE TERMINAL	300
I	ABOVE ADJACENT GROUND OR BALCONY LEVEL	300
J*	FROM SURFACE OR A BOUNDARY FACING THE TERMINAL	600
K	FACING TERMINALS	1200
L	FROM OPENING (DOOR/WINDOW) IN CAR PORT INTO DWELLING	1200
M	VERTICAL FROM A TERMINAL	1500
N	HORIZONTALLY FROM A TERMINAL	300

VERTICAL FLUES

P	FROM ANOTHER TERMINAL	600
Q	ABOVE ROOF LEVEL	300
R	FROM ADJACENT OPENING WINDOW	1000
S	FROM ADJACENT WALL TO FLUE	300

H* and J* These dimensions comply with the building regulations, but they may need to be increased to avoid wall staining and nuisance from plumbing depending on site conditions.

Diagram 4.2

4.1 Flue Options

There are various flue options to choose from as illustrated in diagram 4.1. The flue lengths and installation are described in section 10.

4.2 Flue Terminal Position

In GB the minimum acceptable siting dimensions for the terminal from obstructions, other terminals and ventilation openings are shown in diagram 4.2.

In IE the minimum distances for flue terminal positioning must be those detailed in I.S.813 "Domestic Gas Installations".

The terminal must be exposed to the external air, allowing free passage of air across it at all times.

Being a condensing boiler some plumbing may occur from the flue outlet. This should be taken into consideration when selecting the position for the terminal.

Carports or similar extensions of a roof only, or a roof and one wall, require special consideration with respect to any openings, doors, vents or windows under the roof. Care is required to protect the roof if made of plastic sheeting. If the carport comprises of a roof and two or more walls, seek advice from the local gas supply company before installing the boiler.

NOTE: If the flue terminal is positioned near a light source insects may enter the flue system. Where safe and practical to do so advise the homeowner to check the flue outlet and clear visible insects from the terminal end.

4.3 Terminal Guard

A terminal guard is required if persons could come into contact with the terminal or the terminal could be subject to damage. If a terminal guard is required, it must be positioned to provide minimum of 50mm clearance from any part of the terminal and be central over the terminal.

The guard should be similar to that shown in diagram 4.3.

A suitable guard is manufactured by: -

Tower Flue Components
Morley Rd.
Tonbridge
Kent
TN9 1RA.
Size: 280mm x 165mm. Part No. CGDK3

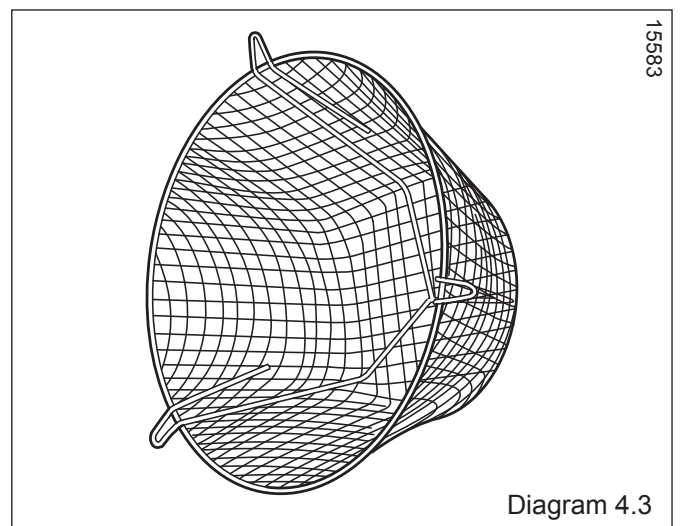

Diagram 4.3

5 Water Systems - General

5.1 General

This boiler is designed to provide central heating from a fully pumped open vented or sealed water system and domestic hot water using a fully indirect cylinder.

5.2 Draining Points

Draining taps must be provided at all low points of the system, which will allow the entire system to be drained. Draining taps shall be to the current issue of BS2879.

5.3 Pump

The pump should be fitted on the flow pipe from the boiler and have isolating valves each side.

A variable duty pump should be set to give a temperature difference of no greater than 20°C between the flow and return, with the thermostat set at "MAX", which is about 80°C, to give a flow rate as given in the table.

See chart for pressure loss of the boiler, diagram 5.1.

High resistance microbore systems may require a higher duty pump.

5.4 Flow Rate

If it is necessary to alter the flow rate, the system can be fitted with a lockable balancing valve in the main flow or return pipes shown in diagram 5.2. The flow rate through the boiler must not be allowed to fall below that given in diagram 5.1.

5.5 Bypass

A system bypass is required and should be fitted at least 1.5 metres away from the boiler, refer to the current issue of the central heating system specifications (CHeSS).

5.6 Unvented DHW System

Where a storage system will not have a vent to atmosphere the installation must comply with the building regulations and the Water Supply (water fittings) Regulations 1999 and water byelaws 2000, Scotland, see also the current issue of BS5546 and BS6700.

If fitting to an existing system the local authority should be informed.

General - All domestic hot water circuits, connections, fittings must be in accordance with the relevant standards and water supply regulations.

For GB: Guidance G17 to G24 and recommendation R17 to R24 of the Water Regulations Guide.

For IE: The current edition of I.S.813 "Domestic Gas Installations".

5.7 Water Treatment

Existing system- It is ESSENTIAL that prior to installing the new boiler the system is thoroughly flushed.

New system- For optimum performance after installation, the boiler and its associated central heating system should also be flushed.

Flushing should be carried out in accordance with BS7593: 2006 using a cleanser such as Sentinel X300 or X400, Fernox Restorer or Salamander corrosion guard cleaner.

IMPORTANT: Ensure all cleanser is removed from the whole system before adding an inhibitor.

For long-term corrosion protection, after flushing, an inhibitor should be used, refer to the current issue of BS 5449 and BS 7593 on the use of inhibitors in central heating systems. Examples are Sentinel X100 Fernox Protector or Salamander corrosion guard inhibitor.

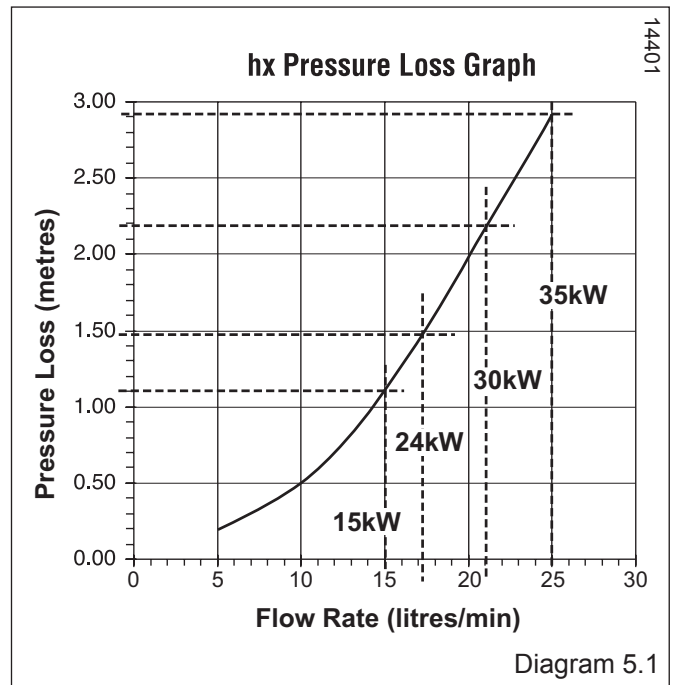

5 Water Systems - Open Vented

5.8 Vented (Open) Water System

The boiler must be supplied from an unrestricted water supply taken from a feed and expansion cistern situated at a maximum height of 27 metres (90ft) above the boiler.

The cold feed must be 15mm minimum size.

The vent must rise continuously and be unrestricted.

It is important that the relative positions of the pump, cold feed and open vent are as shown in diagram 5.2.

5.9 Combined Feed and Vent

For combined feed and vent, a 22mm pipe must be fitted in accordance with BS 5449.

5.10 Domestic Hot Water Cylinder

SINGLE FEED INDIRECT CYLINDERS ARE NOT SUITABLE
The domestic hot water cylinder must be of the double feed fully indirect coil type.

5.11 Draining Points

Draining taps must be provided at the lowest points of the system, which will allow the entire system to be drained.
A draining point for the appliance is provided at the position shown in diagram 5.3.

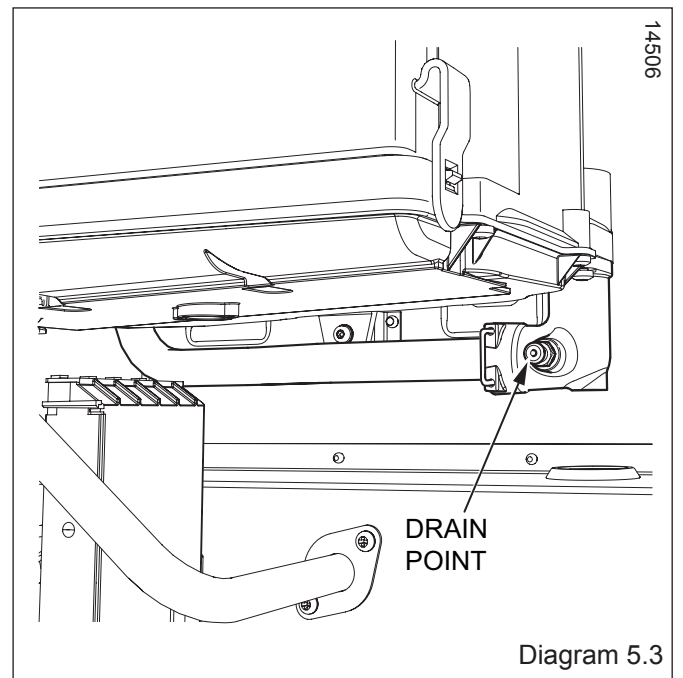
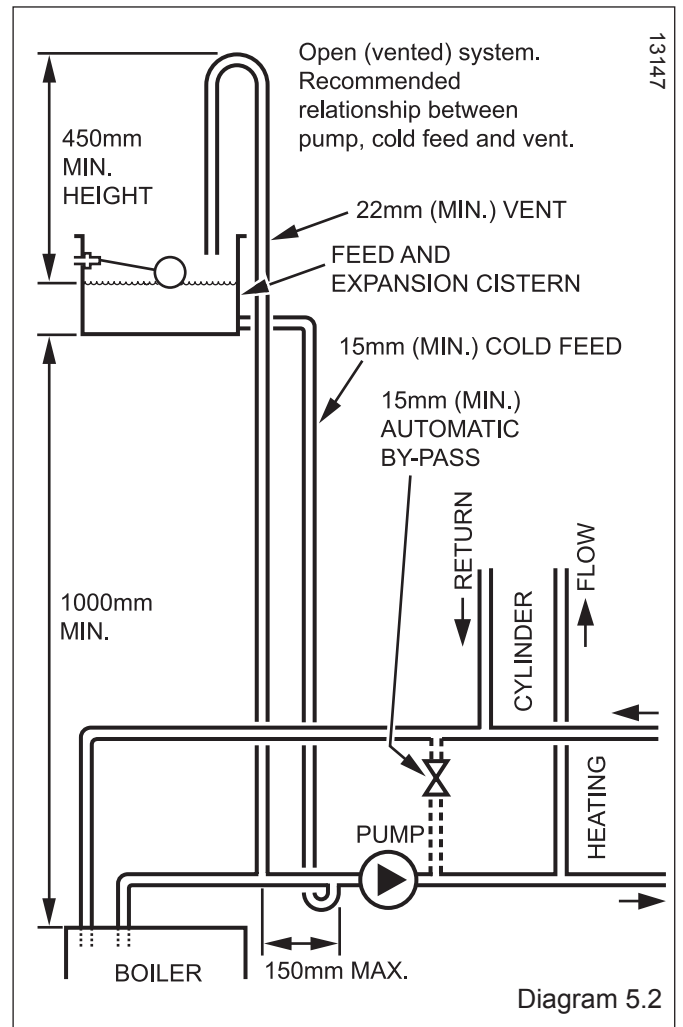

5 Water Systems - Sealed

5.12 Sealed Water Systems

The installation must comply with the appropriate requirements of the current issue of BS4814, BS5449, BS6759, BS6798 and BS7074 Part 1 and 2. See diagram 5.4 for a suggested layout.

5.13 Safety Valve

A safety valve must be fitted to a sealed system. It shall be preset, non-adjustable with a lift pressure of 3 bar, incorporating seating of a resilient material, a test device and a connection for drain. The drain from the safety valve must be routed outside the building, must not discharge above an entrance or window or any type of public access area, be clear of any electrical fittings and positioned so that any discharge can be seen.

5.14 Expansion Vessel

A diaphragm type expansion vessel, conforming to the current issue of BS4814 (see also BS7074 Part 1 and 2) must be connected at a point close to the inlet side of the circulating pump, see the diagrammatic layout, diagram 5.4. The expansion vessel volume depends on the total water system volume and the initial system design pressure. For any system an accurate calculation of vessel size is given in the current issue of BS5449 and BS7074 Part 1. Example: For an initial design pressure of 0.7 bar, the minimum total vessel volume required is $0.063 \times \text{Total System Volume}$.

NOTE: A higher initial design pressure requires a larger volume expansion vessel. Guidance on vessel sizing is also given in the current issue of BS5449 and BS7074 Part 1, for IE refer to the current edition of I.S.813 "Domestic Gas Installations". The charge pressure must not be less than the static head of the system, that is, the height of the highest point of the system above the expansion vessel.

5.15 Pressure Gauge

A pressure gauge with a set pointer and covering at least 0 to 4 bar (0 to 60 lb/in²) shall be fitted permanently to the system in a position where it can be seen when filling the system.

5.16 Domestic Hot Water Cylinder

SINGLE FEED INDIRECT CYLINDERS ARE NOT SUITABLE
The domestic hot water cylinder must be of the double feed fully indirect coil type. It must be suitable for working at a gauge pressure of 0.35 bar above the safety valve setting.

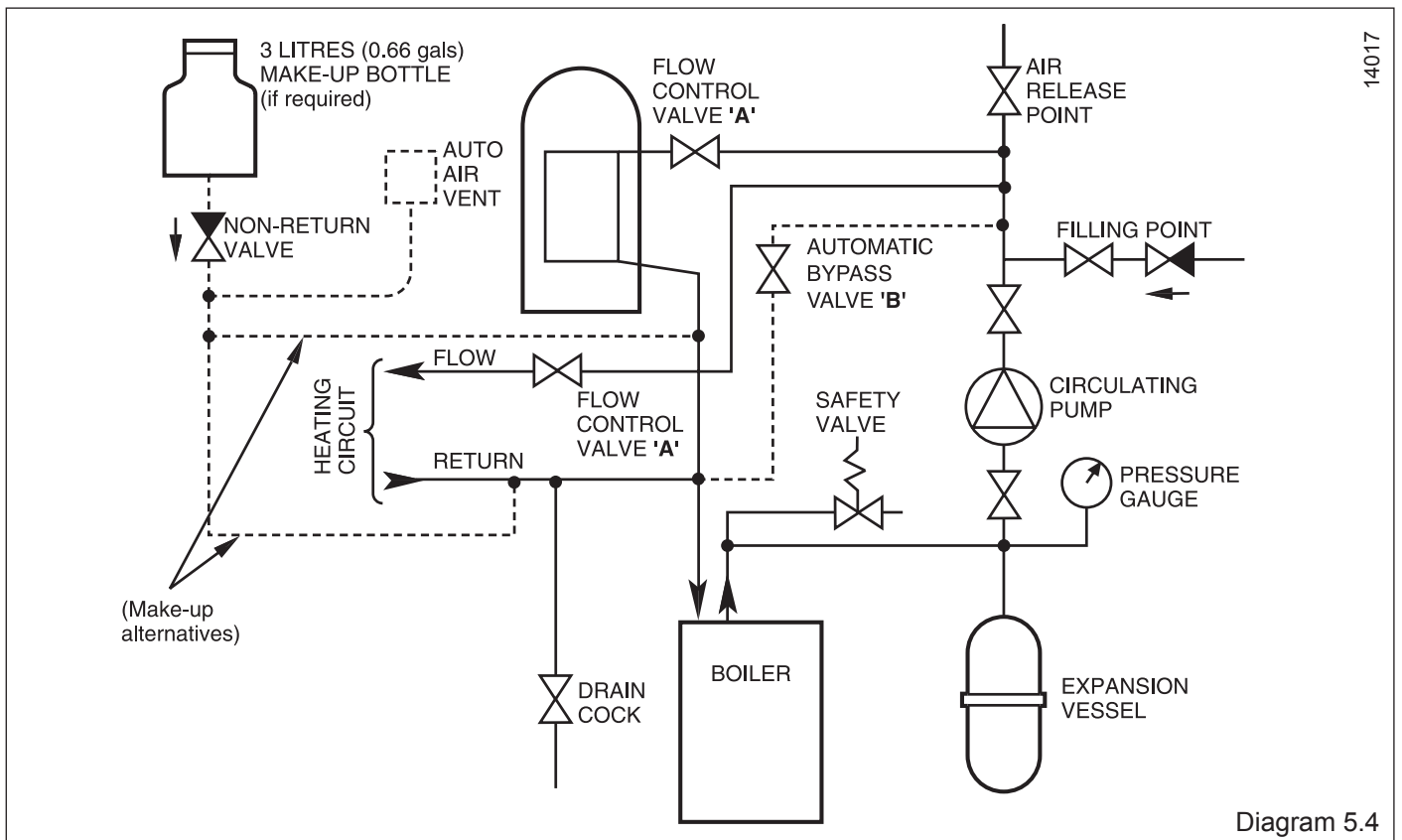

5 Water Systems - Sealed

5.17 Water Makeup

Provision should be made for replacing water loss from the system using a make up bottle mounted in a position higher than the top point of the system, connected through a non-return valve to the return side of either the heating circuit or the hot water cylinder.

Alternatively, provision for make up can be made using a filling loop.

5.18 Filling a Sealed Water System

Provision for filling the system at low level must be made, see diagram 5.5. There must be no permanent connection to the mains water supply, even through a non-return valve.

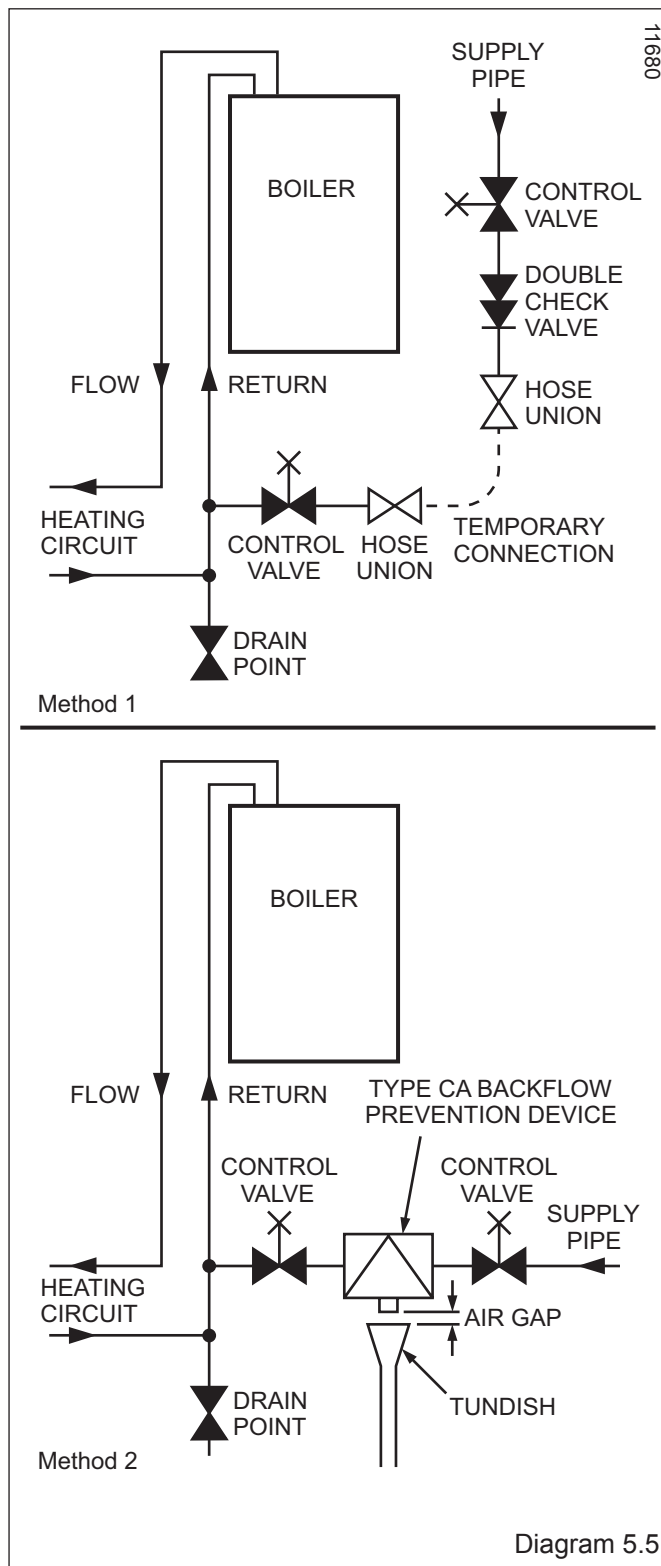

6 Installation Preparation

6.1 Appliance Pack

Please check the contents of packs as shown in diagram 6.1.

The packs are located in the top polystyrene packing.

Remove the carton sleeve and top pack then lift the boiler and its polystyrene base support out of the lower pack.

6.2 Site Requirements

The boiler mounting wall should be suitable for the weight of the appliance and be true and flat.

NOTE: Due to the varied site conditions we do not supply fixings and advise that the installer should supply those which are suitable.

6.3 Wall Template

Take the wall template from the document pack located within the top polystyrene packing and place in the desired position on the wall, giving due consideration to the required boiler clearances, see section 3, and the flue you are fitting.

Mark the position of the flue centre, if fitting a side flue, extend the flue centre line into the corner then 149mm along the adjacent wall, see diagram 6.2.

For extended side flues, the flue hole centre should be determined by extending the dashed inclined line on the template to the side wall, then 149mm along the adjacent wall, see diagram 6.2. This dashed line is drawn at 44mm/metre (2.5°) rise from the boiler.

To allow for the flue passing through the wall at this angle a 125mm hole should be drilled irrespective of internal or external installation.

Remove the wall template whilst drilling the flue hole.

6.4 Flue Hole Cutting

External access flue installation can use a 105mm diameter core drill.

Internal access only flue installation will need a 125mm diameter core drill.

NOTE: The flue is designed with an internal fall of 44mm/metre (2.5°), therefore the hole can be drilled horizontally.

If flue extension pipes are to be used then a core drill size of 125mm is required. This will allow the extension pieces to slope at 44mm/metre (2.5°) towards the boiler.

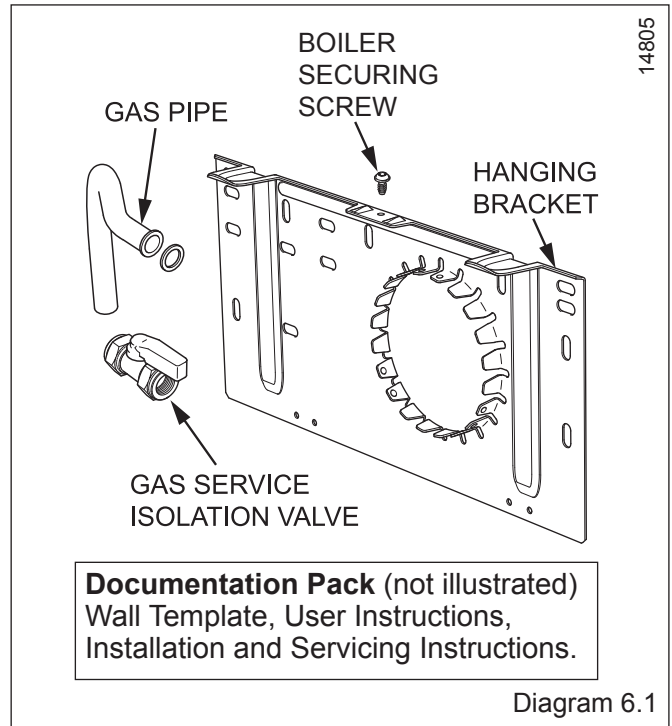

Diagram 6.1

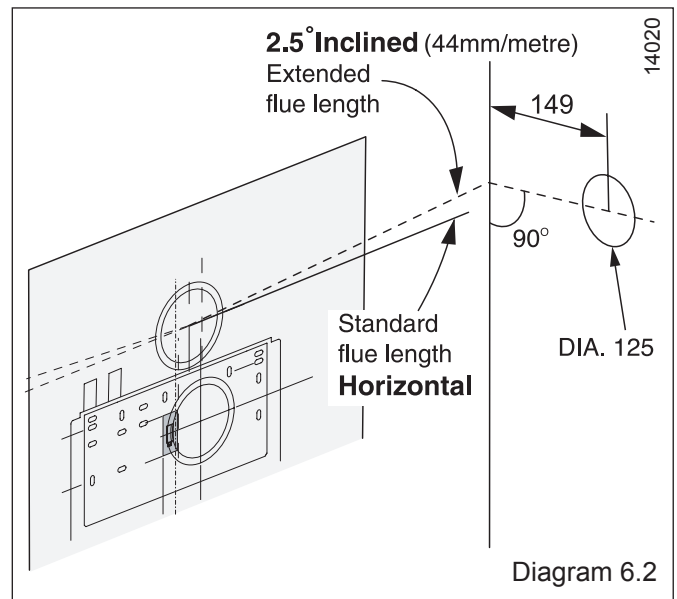

Diagram 6.2

7 Boiler Fixing

7.1 Wall Hanging Bracket

The Wall Hanging Bracket is supplied in the main boiler packaging.

Reposition the wall template over the flue hole and mark the position of the fixing holes for the hanging bracket, see diagram 7.1.

NOTE: Due to the varied site conditions we do not supply fixings and advise that the installer should supply those which are suitable.

Drill fixing holes and insert suitable wall plugs.

Direct Rear Flue only - If external access is not available the flue to be used should be assembled as described in sections 10.11 to 10.13 and inserted through the hole in the wall before fitting the wall hanging bracket.

7.2 Boiler Hanging

IMPORTANT: With regards to the Manual Handling Operations, 1992 Regulations, the following lift operation is deemed to be a one man lift, refer to section 17 Manual Handling.

IMPORTANT: Direct Rear Flue only - The direct rear flue must be fitted before hanging the boiler, refer to sections 10.11 to 10.13, and the rear outlet cover plate should be removed.

Lifting the boiler into position, lean the top of the boiler slightly to the wall and position just above the hanging bracket. Lower the boiler slowly, push back and engage onto the hanging bracket making sure the boiler is located over the retaining bosses, secure with screw provided, see diagram 7.2.

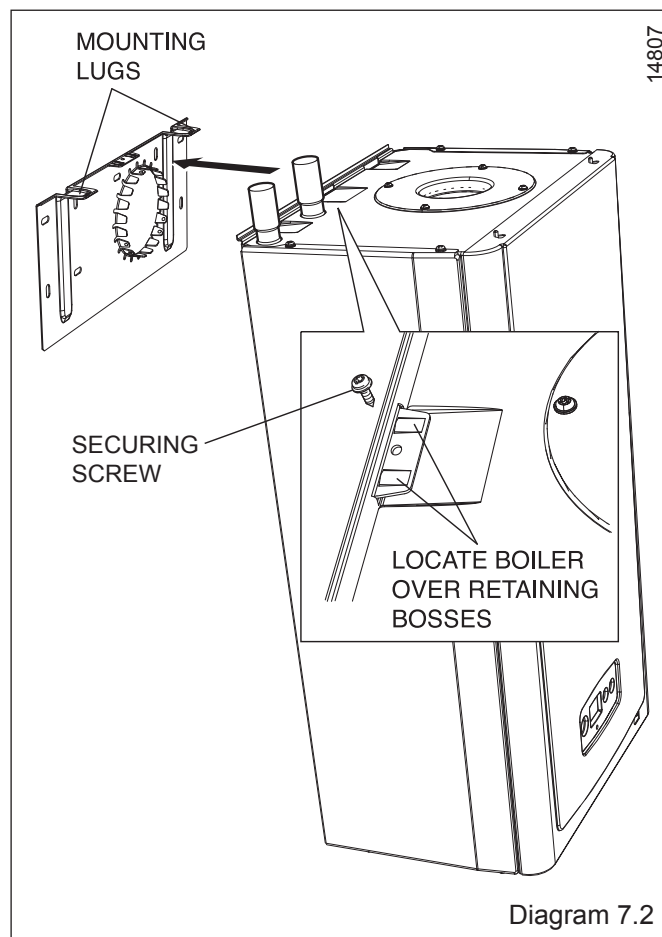
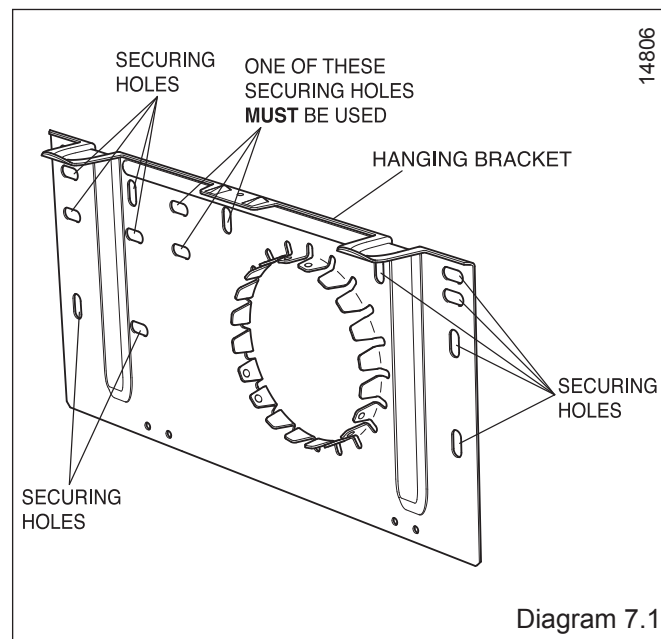

8 Gas / Water and Appliance Connection

8.1 Gas Connection

Before connection check the supply of local gas. The gas supply connection is below the boiler, see diagram 8.1. The whole of the gas installation, including the meter, should be inspected, tested for tightness and purged in accordance with the current issue of BS6891 and in IE the current edition of I.S.813 "Domestic Gas Installations".

8.2 Water Connections

Provision is made for the water connections to be made from above the boiler, see diagram 8.1. The position is shown on the wall template. Flush out the domestic hot water and the heating systems before connecting to the boiler.

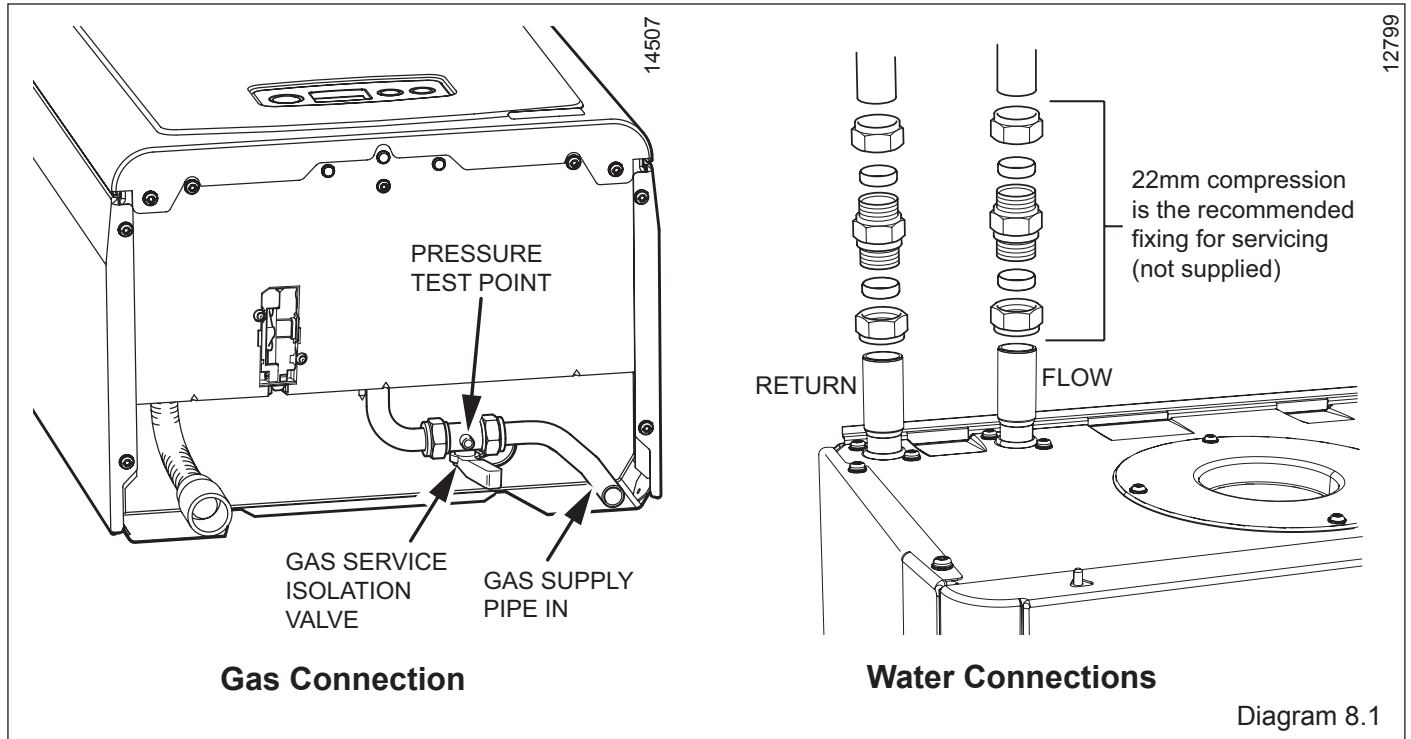

9 Condensate Connections

9.1 Condensate Drain Connection

The condensate drain connection, is positioned below the boiler as shown in diagram 9.1. To discharge condensate to a drain, the drain pipe should have a fall of a least 44mm/metre (2.5°) away from the boiler.

Condensate should, if possible be discharged into the household internal drainage system. If this is not practicable, discharge can be allowed into the external household drains or a purpose designed soak away, refer to diagram 9.2. It is recommended that any external condensate drain pipe is protected and also preferably of 32mm diameter, to prevent freezing in adverse weather conditions.

The condensate is discharged periodically in 'slugs' by siphonic action.

It is not necessary to provide air breaks or extra traps in the discharge pipe as there is already a trap inside the boiler. Fitting an extra trap may cause the boiler siphon to work incorrectly.

Refer to BS5546 or BS6798 for advice on disposal of boiler condensate.

WARNING: This appliance must be earthed.

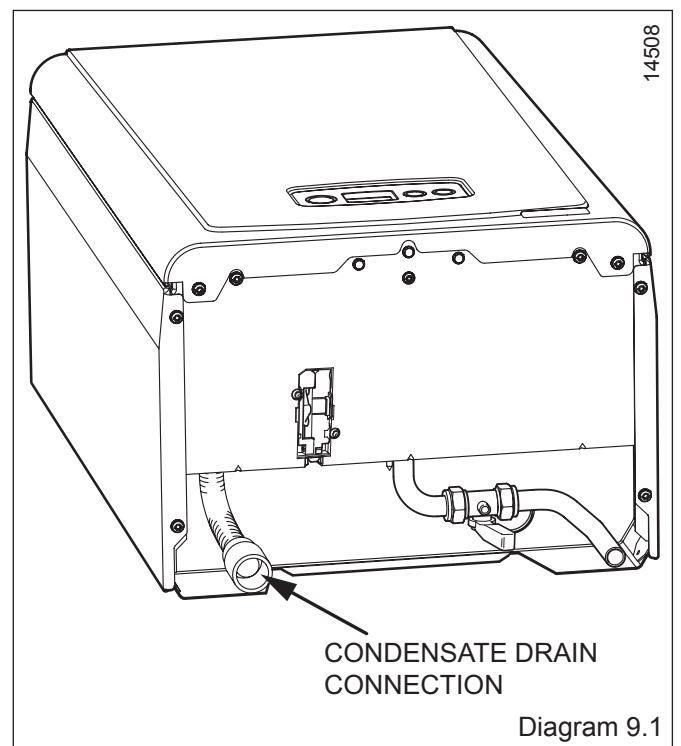

9 Condensate Connections

13000

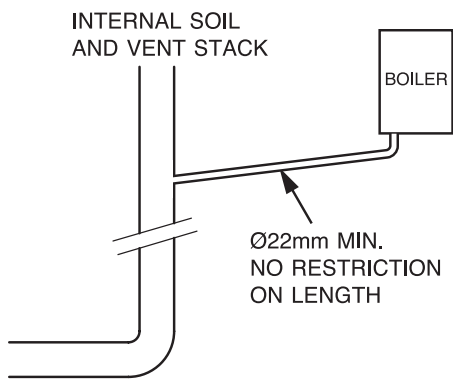

Internal Soil and Vent Pipe

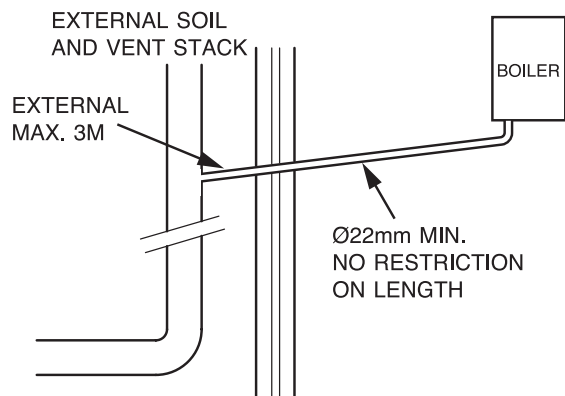

External Soil and Vent Pipe or Rainwater Pipe

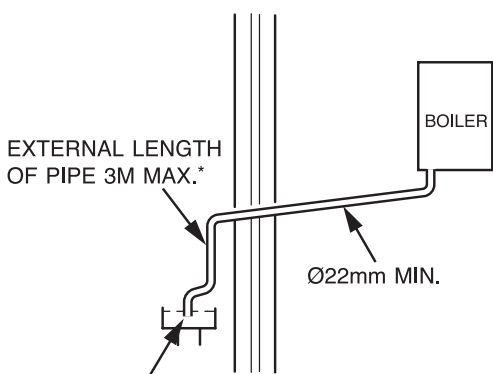

EXTERNAL LENGTH OF PIPE 3M MAX.*
 OPEN END OF PIPE DIRECT INTO GULLEY BELOW GROUND BUT ABOVE WATER LEVEL

*NOTE: FOR EXTENDED PIPE RUNS 32mm DIA. PIPE SHOULD BE USED.

External Termination to a Gulley or Hopper

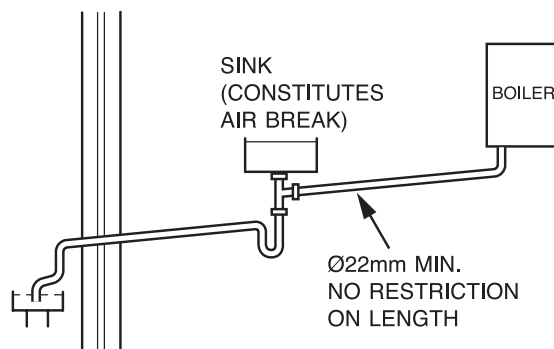

Internal Termination into Combined Sink Waste

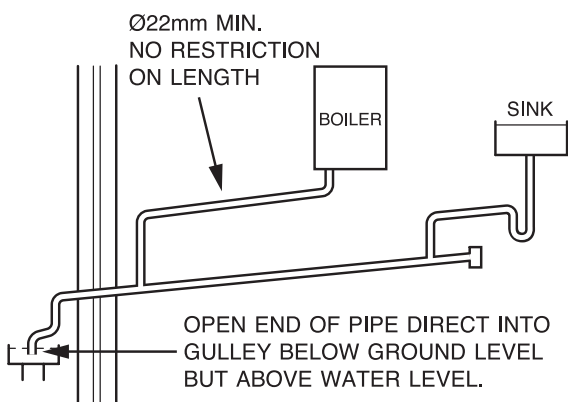

Internal Termination Downstream of Sink Waste

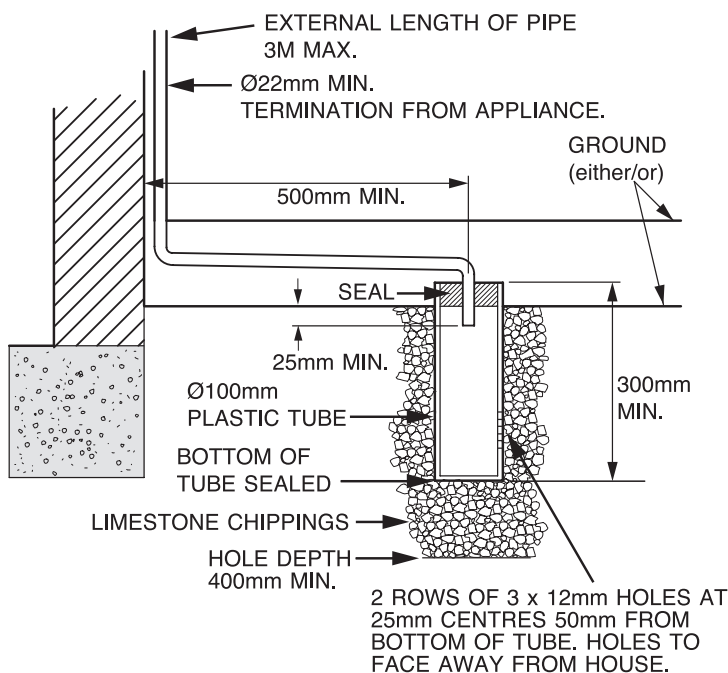

External Termination into Soakaway

NOTE: PIPEWORK SHOULD ALWAYS FALL AWAY FROM BOILER BY AT LEAST 2.5°
 44mm FOR EVERY 1M.

Diagram 9.2

10 Telescopic Flue - Length, Preparation and Installation

10.1 Flue Length

The maximum permissible horizontal flue length is 8 metres plus the flue terminal assembly, this can be achieved by use of the accessories, see diagram 10.3.

However should an additional 87.5° or 2 x 45° elbows be used then the length MUST be reduced by 1metre.

The diagram 10.1 shows the length achievable by using the kit A2043600.

When extension pipes are used the flue system must be designed to have a continuous fall to the boiler of at least 2.5° 44mm/metre to allow condensate to run back into the boiler and out via the condensate drain.

The flue can be installed from inside the building, when access to the outside wall face is not practicable.

Multiple Boiler Chimney Flue Length

The flue length must be calculated and installed according to the relevant standards EN 13384-1 and 2 (C43 flue systems only) with reference to the table below and the manufacturers instructions supplied.

The appliance maximum flue length must be included when calculating the overall design of the flue system.

NOTE: The horizontal flue terminal must be removed, see diagram 10.2.

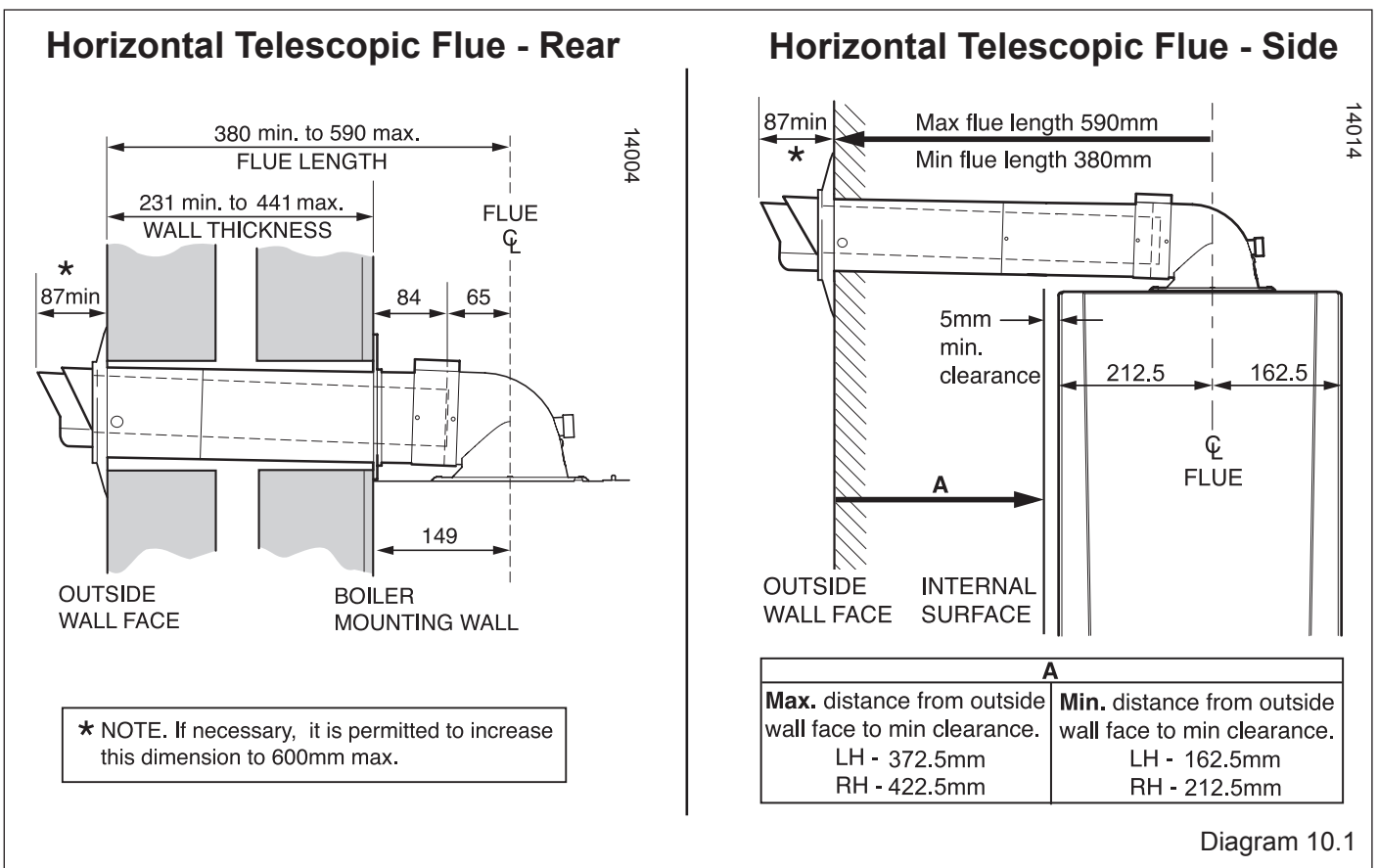

	Flexicom 12hx	Flexicom 15hx	Flexicom 18hx	Flexicom 24hx	Flexicom 30hx	Flexicom 35hx
Exhaust mass rate (g/s)						
At Min Thermal Load (40C°/30°C)	4.30	4.30	4.30	4.30	4.30	4.30
At Max Thermal Load (80C°/60°C)	5.54	6.91	8.33	11.17	14.10	16.39
Exhaust temperature (°C)						
At Min Thermal Load (40C°/30°C)	33.2	33.2	33.2	33.2	33.2	36.0
At Max Thermal Load (80C°/60°C)	55.8	58.3	63.0	73.3	87.4	84.0

10 Telescopic Flue - Length, Preparation and Installation

14826

Top Outlet Horizontal Concentric Flue Packs:
A2043600 Horizontal telescopic flue pack.

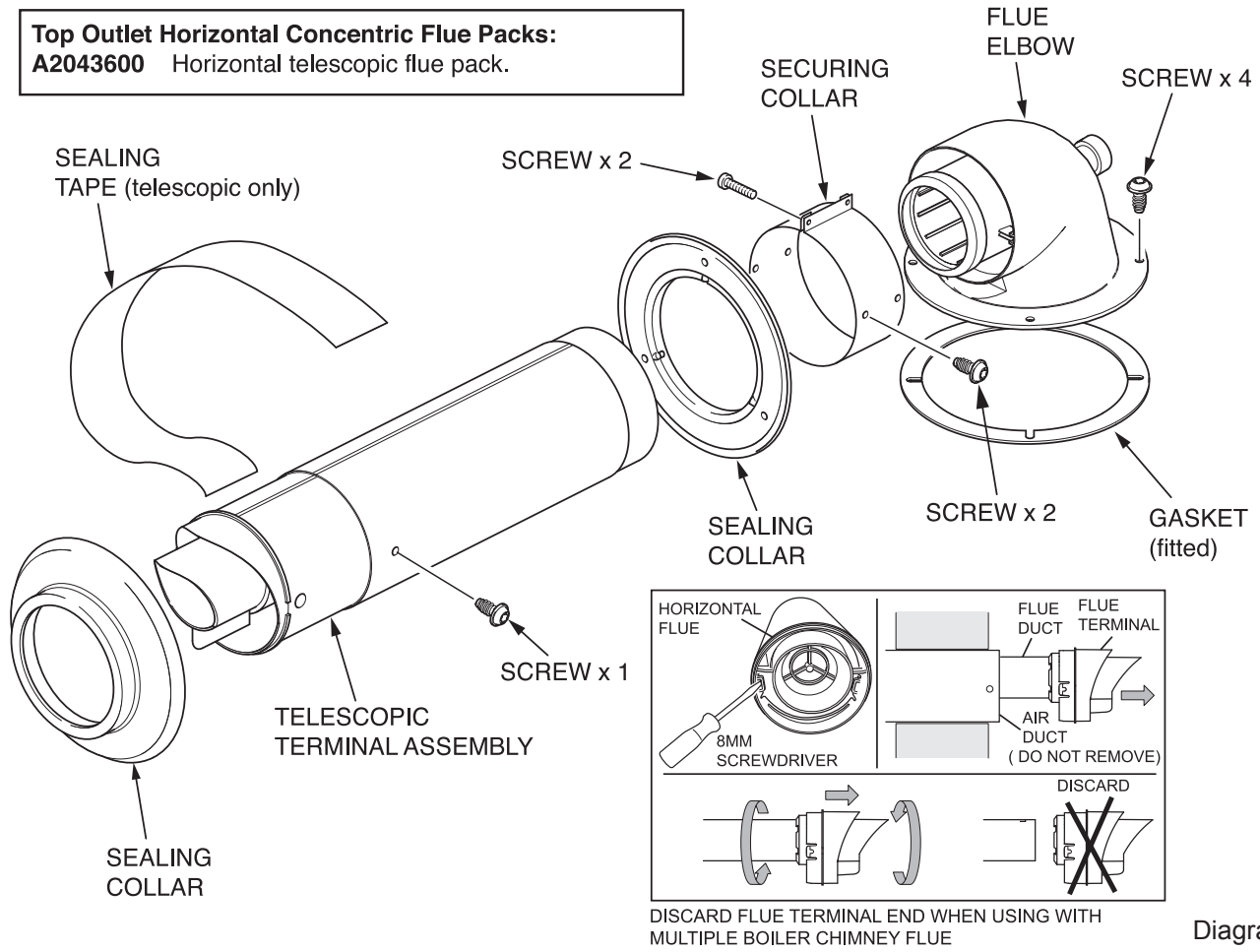

DISCARD FLUE TERMINAL END WHEN USING WITH MULTIPLE BOILER CHIMNEY FLUE

Diagram 10.2

15418

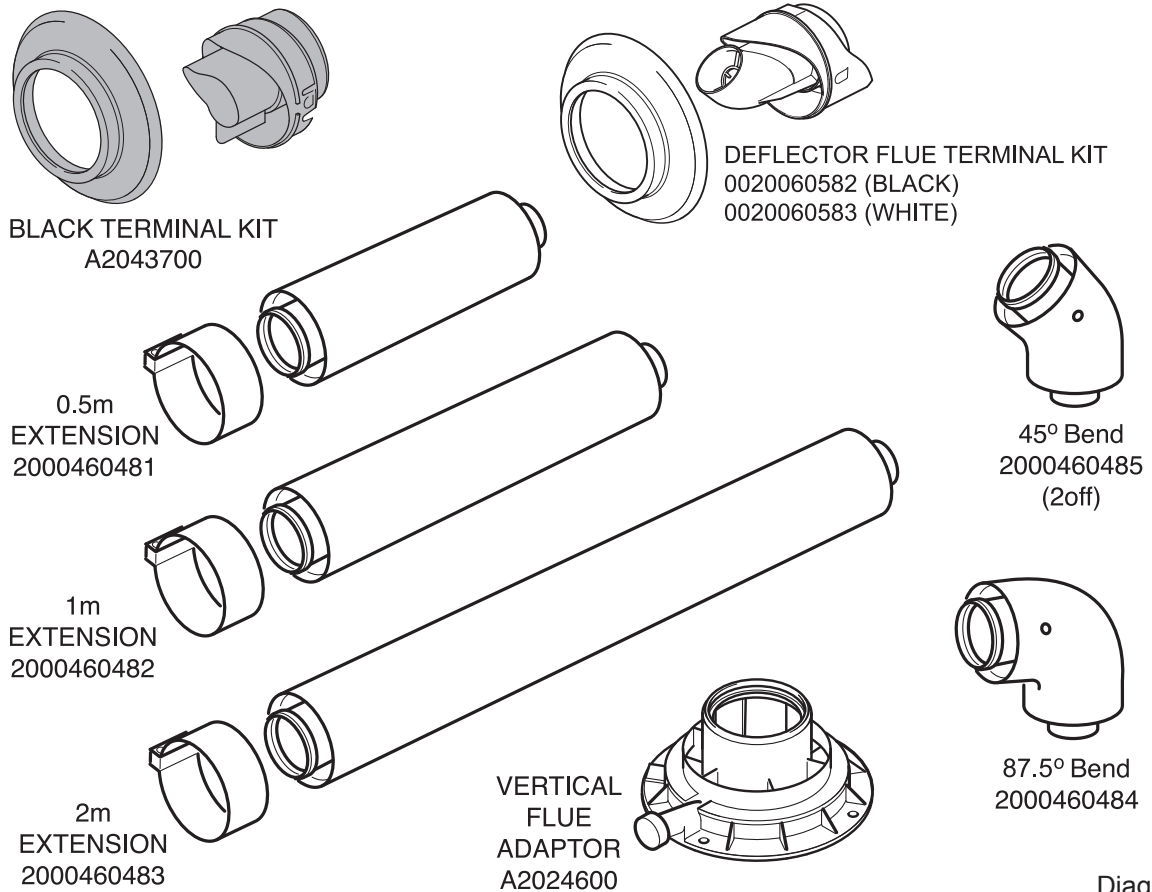

Diagram 10.3

10 Telescopic Flue - Length, Preparation and Installation

10.2 Horizontal Telescopic Flue - A2043600

Refer to diagram 10.2 for kit contents.

10.3 REAR Flue

If a wall thickness is between 231mm min. to 441mm max. then the flue can be used without extensions.

Remove the top flue outlet cover secured with four screws, see diagram 10.4.

Using these screws inserted into the same holes on the boiler, temporarily secure the flue elbow, measure the distance from the outside wall to the butt joint, see diagram 10.5. If the measurement 'Y' exceeds 525mm, then the appropriate length of extension pipe is required.

If the dimension is less than 315mm DO NOT cut the flue, it can project to a maximum of 600mm, refer to diagram 10.6. If this is not desirable then a Standard flue MUST be used and cut to length.

10.4 SIDE Flue

Remove the top flue outlet cover secured with four screws, see diagram 10.4.

Using these screws inserted into the same holes on the boiler, temporarily secure the flue elbow, measure the distance from the outside wall to the butt joint, see diagram 10.7. If the measurement 'Y' exceeds 525mm, then the appropriate length of extension pipe is required.

If the dimension is less than 315mm DO NOT cut the flue, it can project to a maximum of 600mm, refer to diagram 10.6. If this is not desirable then a Standard flue MUST be used and cut to length.

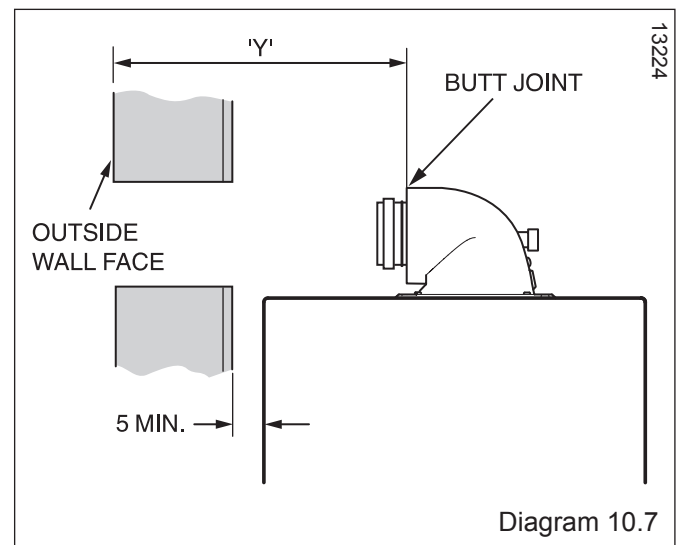
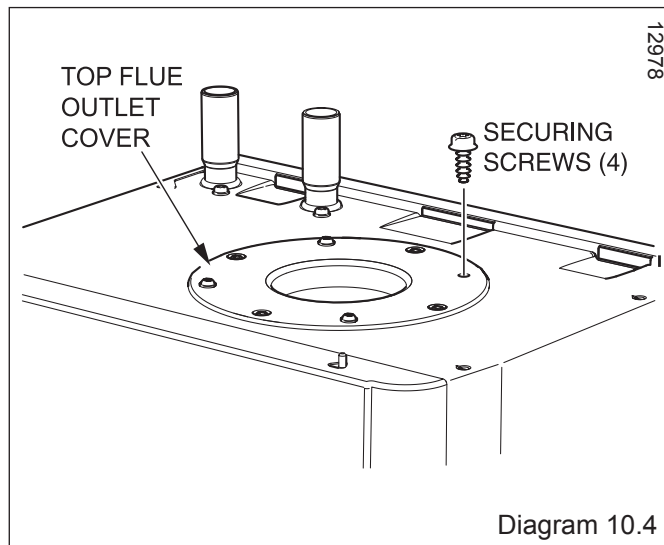
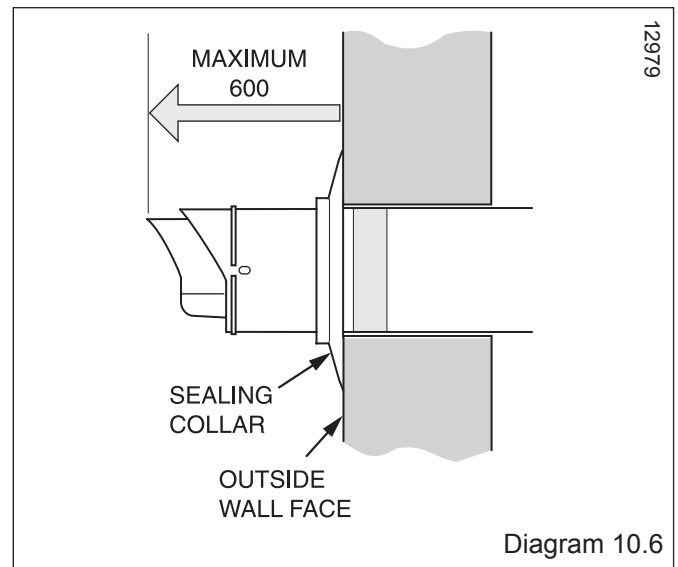
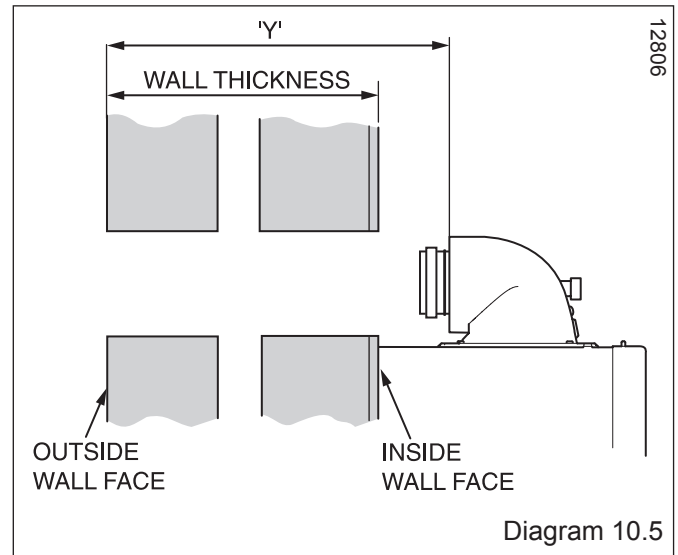

10 Telescopic Flue - Length, Preparation and Installation

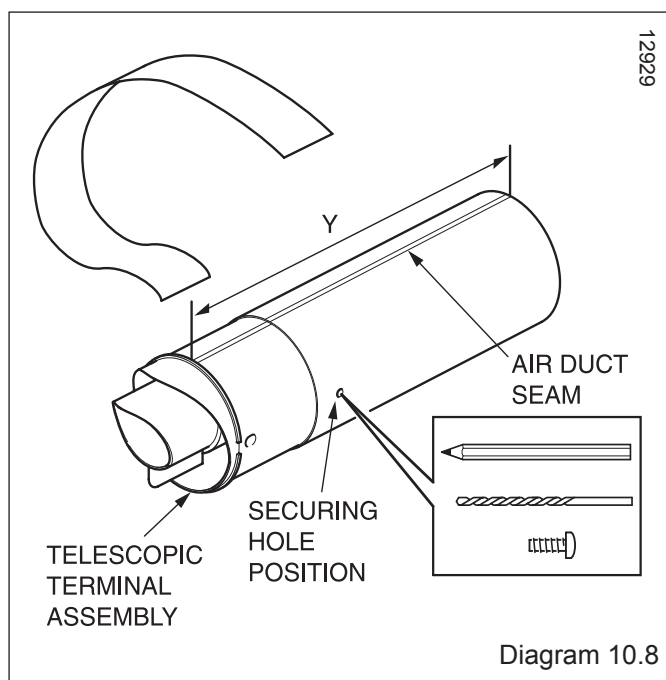

10.5 Flue Fitting

IMPORTANT:-

The flue seals are sensitive to mineral oil based lubricants. **Do not grease the seals.** If the seals do need to be lubricated **use only water.**

During the installation of the flue system, ensure that debris such as mortar, filings or swarf are cleared from the flue system before completion.

Inspect the flue pipes before fitting and do not install damaged or dented flue components.

When assembling the flue system, ensure that the inner seals are not damaged, do not install a flue component with a damaged seal.

When fitting flue elbows ensure that they are fitted at the correct angle to avoid strain, this will ensure that the seal fits correctly preventing leakage.

With the air duct seams aligned and the flue set to the required length 'Y', mark the securing hole position in the air duct. Drill a 3mm diameter hole at this position, take care not to pierce the inner flue duct. Secure with screw provided and tape the joint, see diagram 10.8.

Fit the sealing collar onto the locating ring on the flue terminal, see diagram 10.9.

With the flue elbow removed, push the flue assembly into the wall, externally or internally, until the end of the assembly protrudes a short way from the inside face of the wall. This will enable the internal trim ring (if required) to be positioned and allow the flue assembly to be drawn back up to the flue elbow.

Secure the flue elbow in position on top of the boiler with the four screws supplied.

Draw the flue assembly from wall and engage the flue duct into the elbow and butt fit between the air duct and flue elbow. Fit the securing collar into position.

Ensuring correct alignment of the flue, mark through two of the pre drilled holes in the securing collar. Remove securing collar and drill two 3mm diameter holes one in the elbow and one in the air duct, take care not to pierce the inner flue duct. Fit the securing collar and secure with screws provided, see diagram 10.10.

Slide the internal trim ring back against the wall, securing in place with a small amount of sealant if required.

Insert the flue duct into the air duct terminal assembly, remembering to engage the catch within the terminal.

Check that the outer rubber sealing collar makes an effective seal against the wall face.

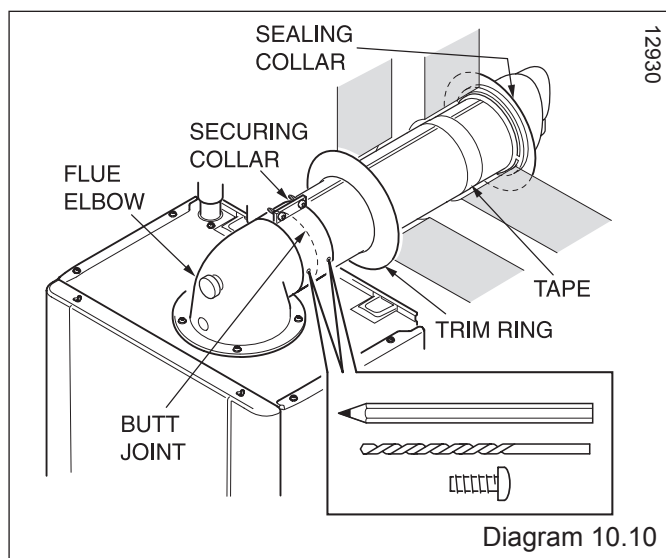
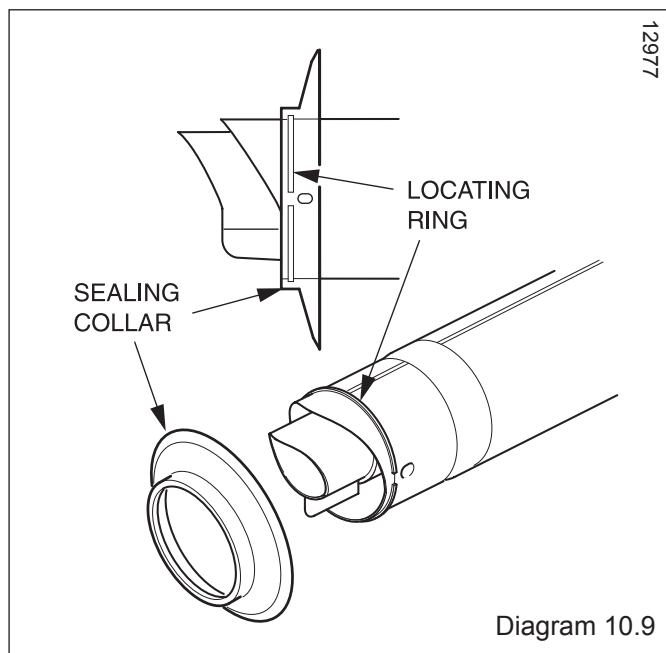

10 Standard Flue - Length, Preparation and Installation

10.6 Flue Length

The maximum permissible horizontal flue length is 8 metres plus the flue terminal assembly, this can be achieved by use of the accessories, see diagram 10.13.

However should additional 87.5° or 2 x 45° elbows be used then the length MUST be reduced by 1metre.

The diagram 10.11 shows the length achievable by using the kit A2043400.

When extension pipes are used the flue system must be designed to have a continuous fall to the boiler of at least 2.5° 44mm/metre to allow condensate to run back into the boiler and out via the condensate drain.

The flue can be installed from inside the building, when access to the outside wall face is not practicable.

Multiple Boiler Chimney Flue Length

The flue length must be calculated and installed according to the relevant standards EN 13384-1 and 2 (C43 flue systems only) with reference to the table below and the manufacturers instructions supplied.

The appliance maximum flue length must be included when calculating the overall design of the flue system.

NOTE: The horizontal flue terminal must be removed, see diagram 10.12.

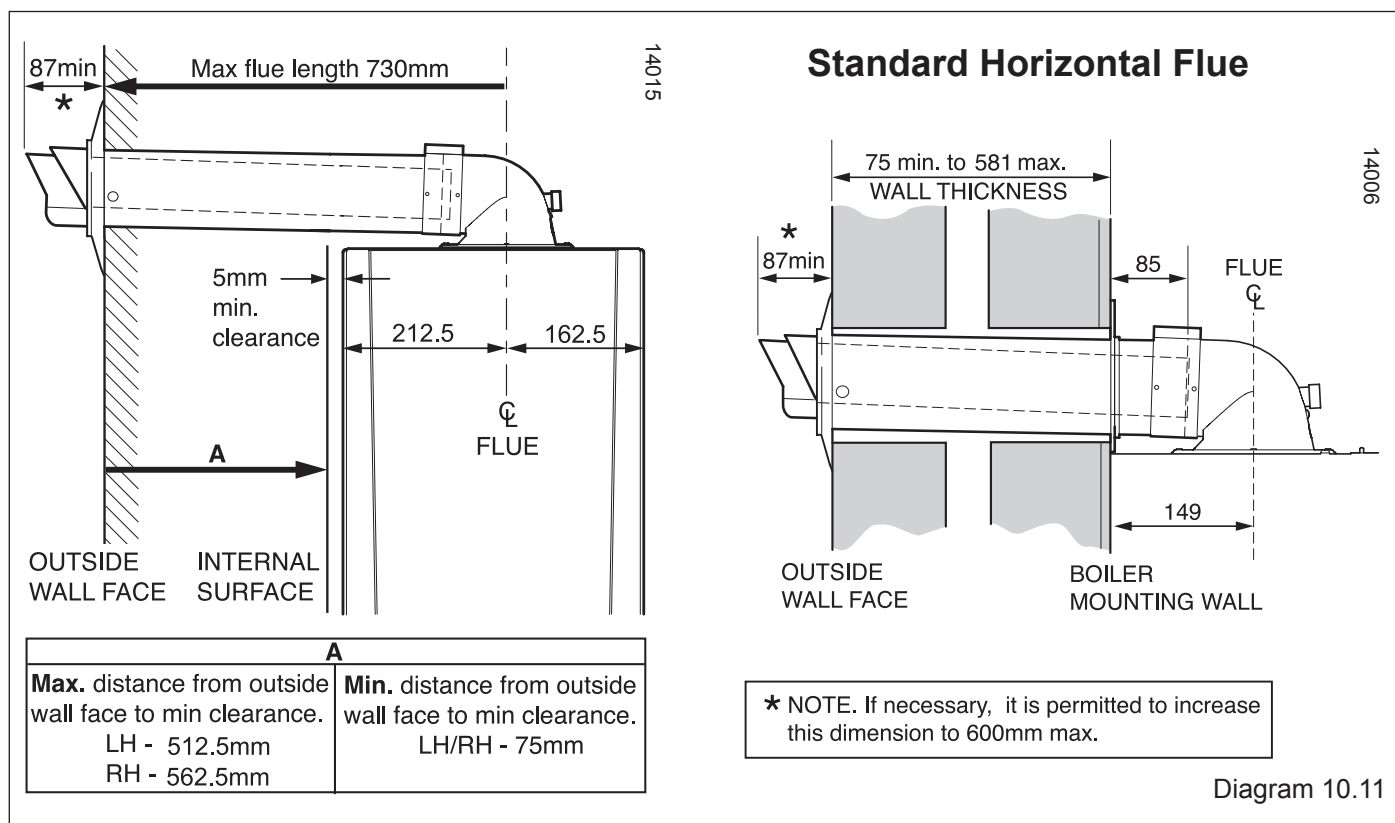

	Flexicom 12hx	Flexicom 15hx	Flexicom 18hx	Flexicom 24hx	Flexicom 30hx	Flexicom 35hx
Exhaust mass rate (g/s)						
At Min Thermal Load (40C°/30°C)	4.30	4.30	4.30	4.30	4.30	4.30
At Max Thermal Load (80C°/60°C)	5.54	6.91	8.33	11.17	14.10	16.39
Exhaust temperature (°C)						
At Min Thermal Load (40C°/30°C)	33.2	33.2	33.2	33.2	33.2	36.0
At Max Thermal Load (80C°/60°C)	55.8	58.3	63.0	73.3	87.4	84.0

10 Standard Flue - Length, Preparation and Installation

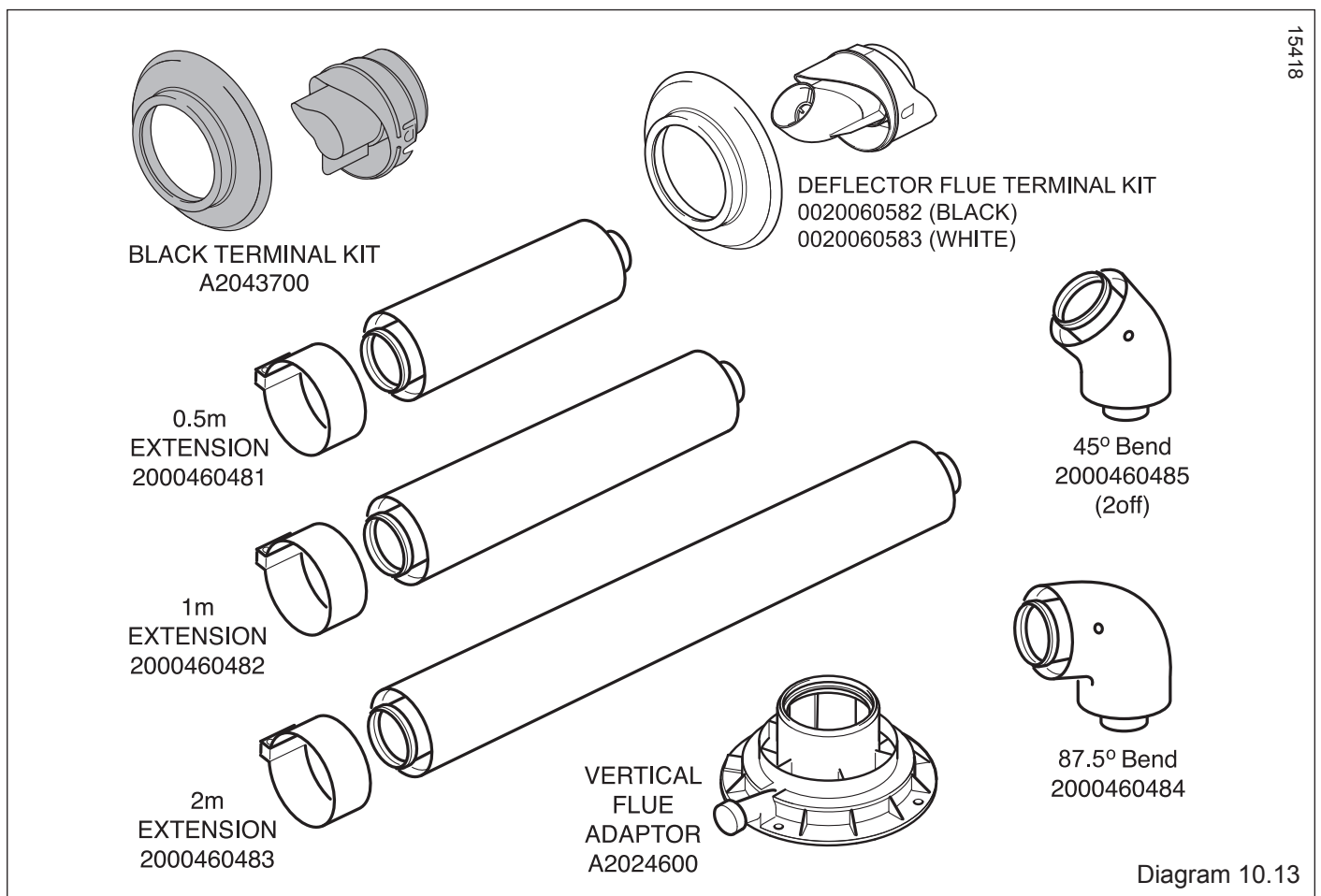
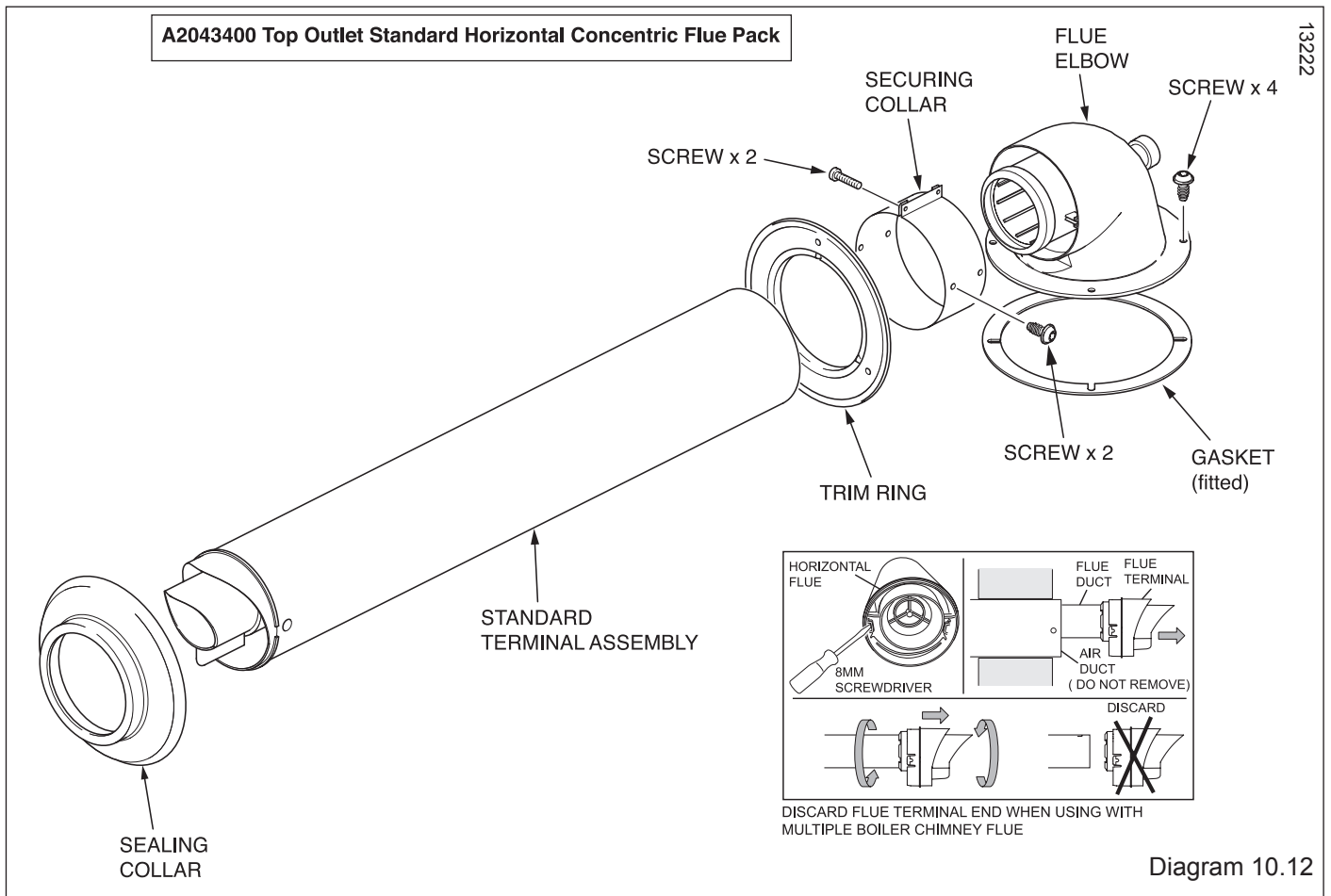

10 Standard Flue - Length, Preparation and Installation

10.7 Standard Horizontal Flue - A2043400

Refer to diagram 10.12 for kit contents.

10.8 REAR Flue

Remove the top flue outlet cover secured with four screws, see diagram 10.4.

Using these screws inserted into the same holes on the boiler, temporarily secure the flue elbow, measure the distance from the outside wall to the butt joint, see diagram 10.14. If the measurement 'Y' exceeds 665mm, then the appropriate length of extension pipe is required. The minimum dimension is 187mm to suit a 75mm min wall thickness. The flue can project to a maximum of 600mm, refer to diagram 10.15.

10.9 SIDE Flue

Remove the top flue outlet cover secured with four screws, see diagram 10.4.

Using these screws inserted into the same holes on the boiler, temporarily secure the flue elbow, measure the distance from the outside wall to the butt joint, see diagram 10.16. If the measurement 'Y' exceeds 665mm, then the appropriate length of extension pipe is required. The minimum dimension for Lhd is 227.5 and Rhd 177.5 to suit a minimum wall thickness of 75mm. The flue can project to a maximum of 600mm, refer to diagram 10.15.

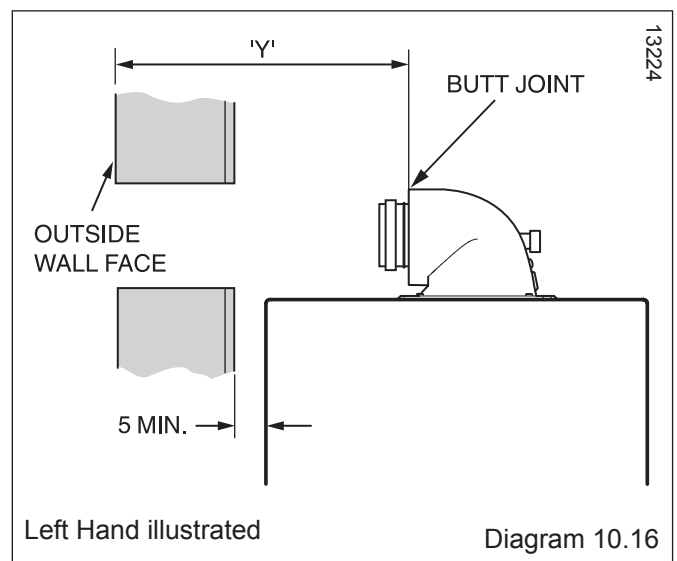
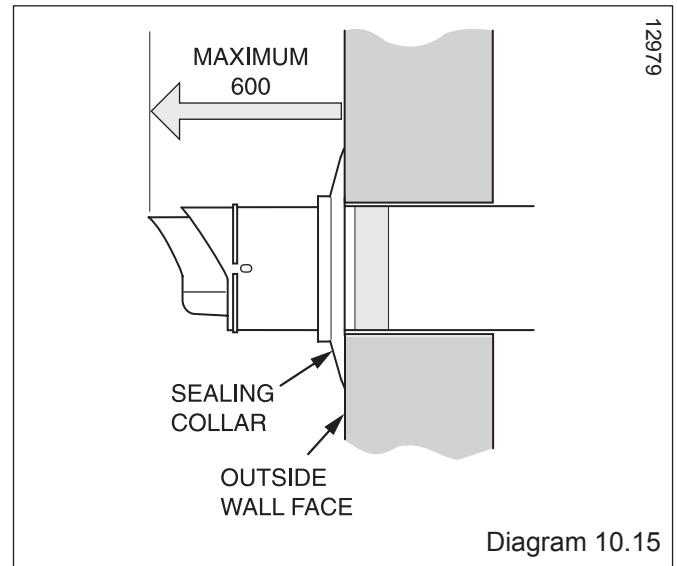
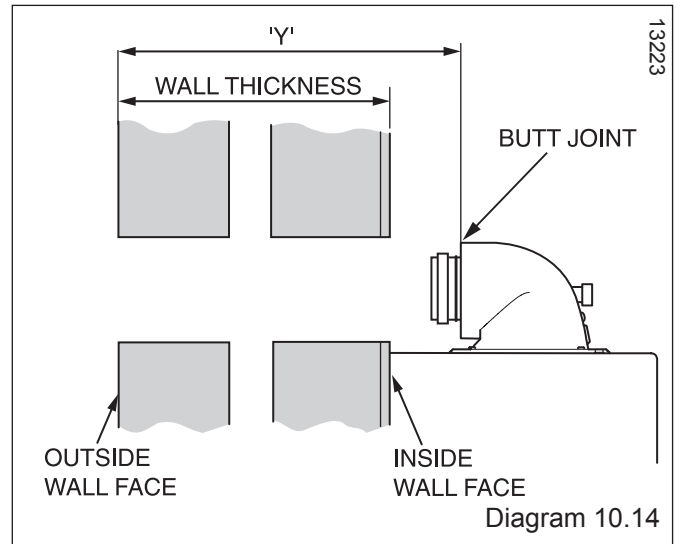

10 Standard Flue - Length, Preparation and Installation

10.10 Flue Fitting

IMPORTANT:-

The flue seals are sensitive to mineral oil based lubricants. **Do not grease the seals.** If the seals do need to be lubricated **use only water.**

During the installation of the flue system, ensure that debris such as mortar, filings or swarf are cleared from the flue system before completion.

Long lengths of flues must be secured to the walls or ceilings they run against. Use at least one fixing bracket for every flue extension that is used.

After cutting inner flue tubes ensure that you de-burr and chamfer the male tube end to prevent damage.

Inspect the flue pipes before fitting and do not install damaged or dented flue components.

When assembling the flue system, ensure that the inner seals are not damaged, do not install a flue component with a damaged seal.

When fitting flue elbows ensure that they are fitted at the correct angle to avoid strain, this will ensure that the seal fits correctly preventing leakage.

Remove the flue elbow.

Separate the flue duct from the terminal by twisting to release the terminal catch, then pull out of the retaining seal, refer to diagram 10.17.

The flue duct cutting length ($L + 11\text{mm}$.) is shown in diagram 10.17.

The air duct should be cut at the opposite end to the terminal

The plastic flue duct **MUST** be cut at the opposite end to the terminal catch.

The plastic flue duct extensions **MUST** be cut at the opposite end to seal.

Insert the flue duct into the air duct terminal assembly, remembering to engage the catch within the terminal.

Fit the sealing collar behind the locating lugs on the flue terminal, see diagram 10.18.

Push the flue assembly into the wall, externally or internally, initially until the end of the assembly protrudes a short way from the inside face of the wall. This will enable the internal trim ring (if required) to be positioned and allow the flue assembly to be drawn back into the flue elbow.

Secure the flue elbow in position on top of the boiler with four torque headed screws supplied.

Draw the flue assembly from wall and engage the flue duct into the elbow and butt fit between the air duct and flue elbow.

Fit the securing collar into position.

Ensuring the correct alignment of the terminal, mark through two of the pre drilled holes in the securing collar. Remove securing collar and drill two 3mm diameter holes one in the elbow and one in the air duct, take care not to pierce the inner flue duct. Fit the securing collar and secure with screws provided, see diagram 10.18.

Slide the internal trim ring back against the wall, securing in place with a small amount of sealant if required.

NOTE: If the air and flue ducts have been correctly cut to the instructions the sealing collar should fit flush with the outside wall.

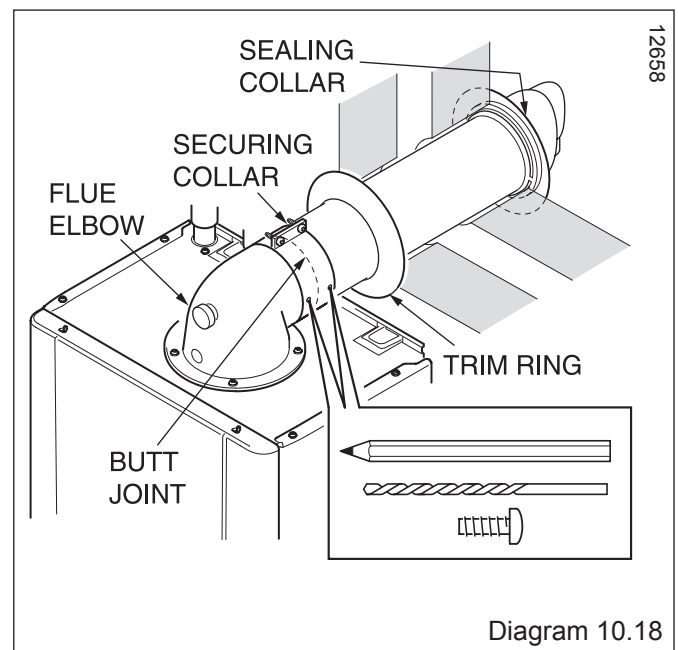
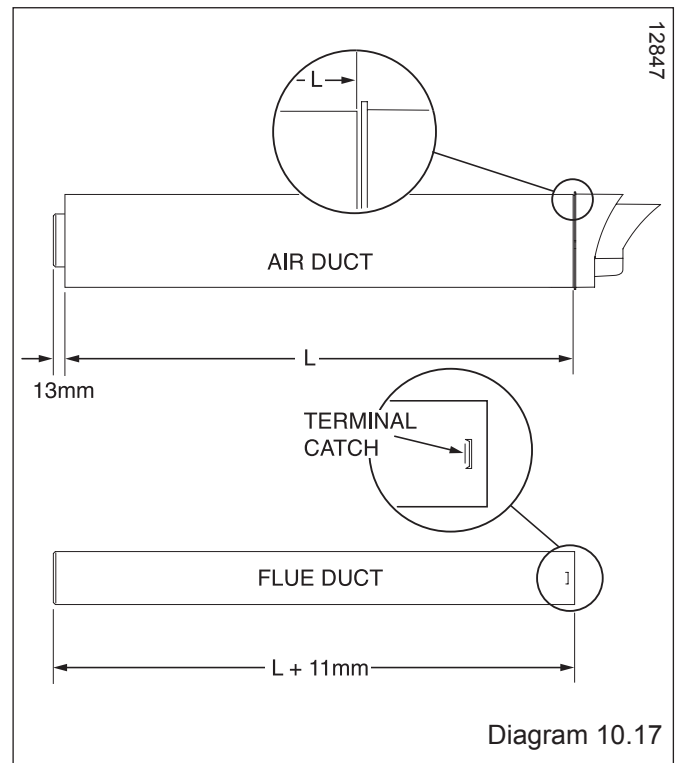

10 Direct Rear Flue - Length, Preparation and Installation

10.11 Direct Rear flue - Telescopic

Part No. A2043500.

Refer to diagram 10.19 for kit contents.

10.12 Flue Length

Measure the distance from the outside wall to the inside wall face. This measurement must not exceed 512mm (465mm if the upward piping kit is used). If the dimension is less than 291mm DO NOT cut the flue, it can project to a maximum of 600mm, see diagram 10.15.

10.13 Flue Fitting

Set the flue to the required length 'Y' plus 24mm min to 28mm max, see diagram 10.20, ensure the air duct seams line up. Mark the securing hole position in the air duct. Drill a 3mm diameter hole at this position, take care not to pierce the inner flue duct. Secure with screw provided and tape the joint, see diagrams 10.19.

Fit the sealing collar onto the locating ring on the flue terminal, see diagram 10.19.

Push the telescopic terminal assembly into the wall, externally or internally, initially.

Draw the telescopic flue through the wall and engage the telescopic terminal assembly into the clamping band grips. The telescopic terminal assembly must be pulled forward of the clamping band grips by the dimension shown in diagram 10.21 to ensure a good seal when the boiler is located onto the fixing plate.

Ensure the correct alignment of the terminal.

There are two alternative methods of securing the flue:-

Method (1) There are six holes provided in the clamping band grips, three of these should be used to secure the flue. Mark and drill 3mm holes in the air duct then secure to the clamping grip with the screws provided.

Method (2) Secure the telescopic terminal assembly using the clamping band supplied. The position of the clamping band securing screw is important, refer to label and wall template.

IMPORTANT: CHECK THE CLAMPING BAND IS SUFFICIENTLY TIGHTENED TO AVOID ANY MOVEMENT OF THE FLUE WHEN FITTING THE BOILER.

Continue at the appropriate paragraph of section 7.

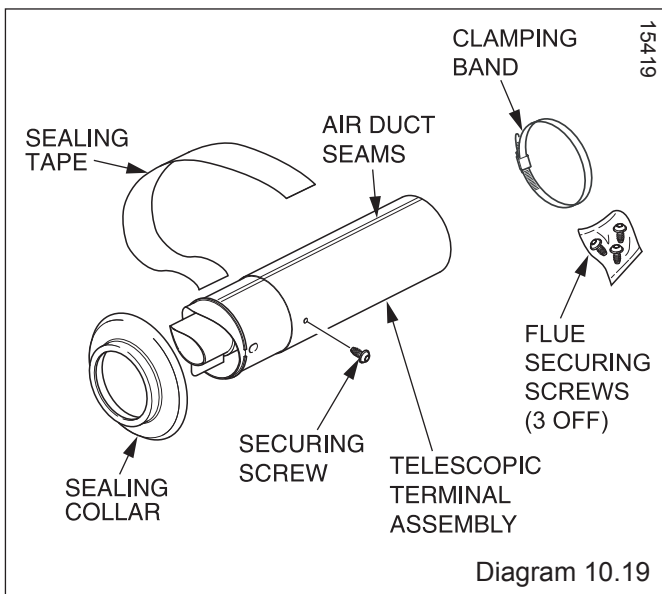
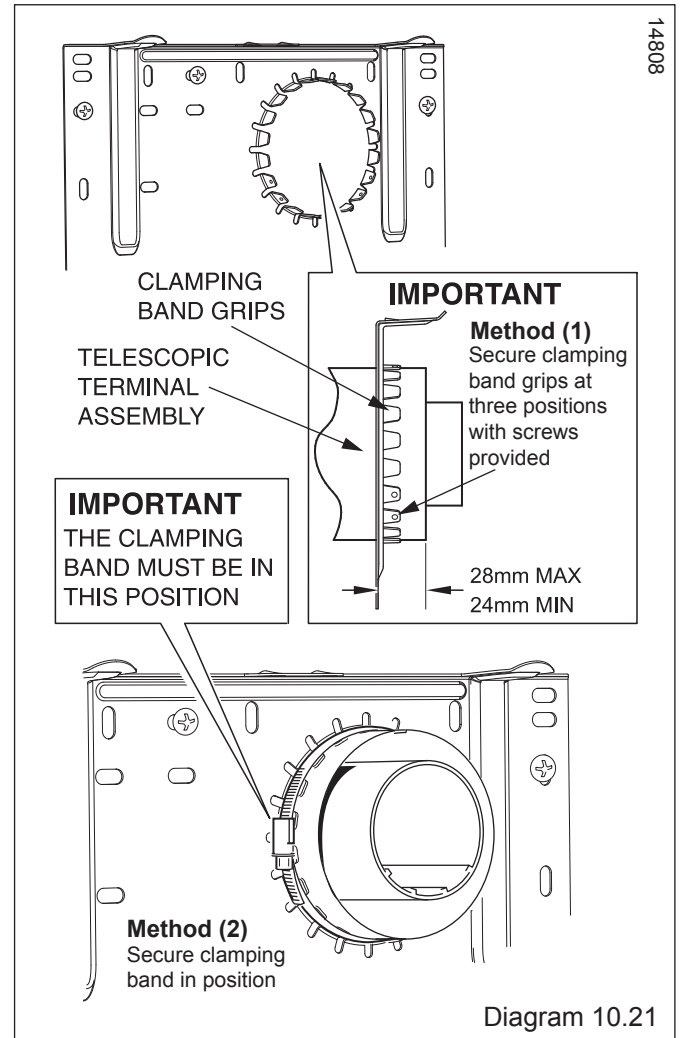
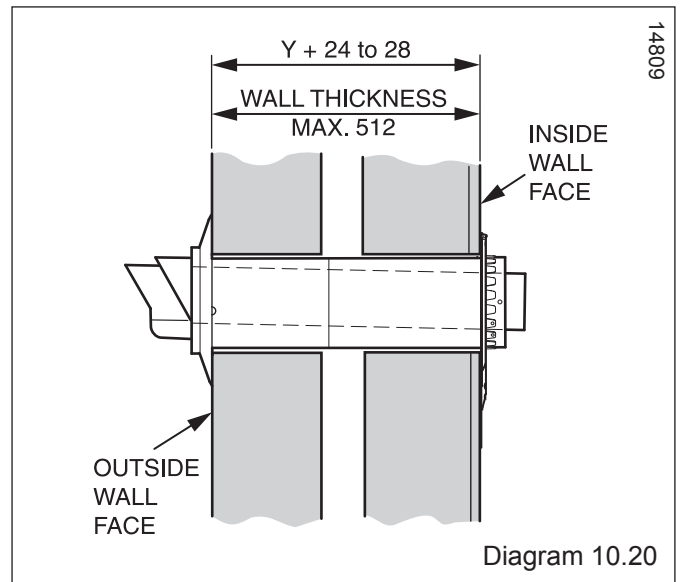

10 Vertical Flue - Length, Preparation and Installation

10.14 Vertical flue

The vertical flue system is available as an option where the boiler position does not permit the use of the top horizontal flue system.

The system is made up from accessories. The accessories include terminal assembly, bends 45° and 87.5°, flue extensions, fixing bracket and appropriate weather collar, see diagram 10.23.

The maximum permitted straight flue length is 8 metres plus the terminal. for each 87.5° or 2x45° bends fitted, the maximum length must be reduced by 1 metre, see diagram 10.22.

NOTE: 2x45° bends can replace 1x87.5° bend if necessary. When using 87.5° bends any horizontal extension pipe should be inclined by a minimum of 44mm/metre (2.5°) towards the boiler to facilitate condense removal, see (a) in diagram 10.22.

Alternatively use 45° bends to avoid horizontal runs, see (b) in diagram 10.22.

The terminal siting should be as shown in diagram 4.2.

Measure the distance of flue length required for the installation.

The flue must be designed with a continuous fall towards the boiler.

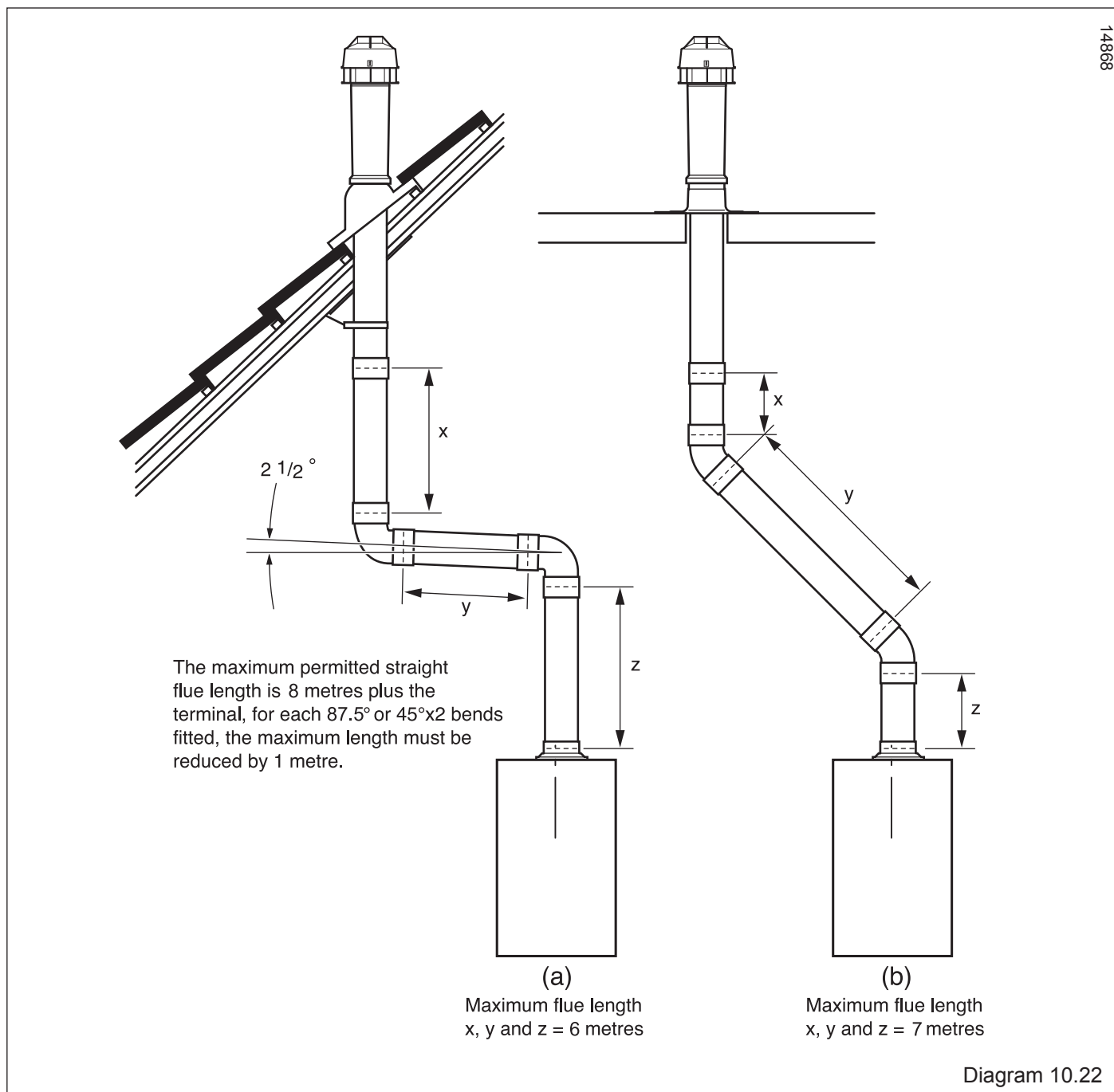
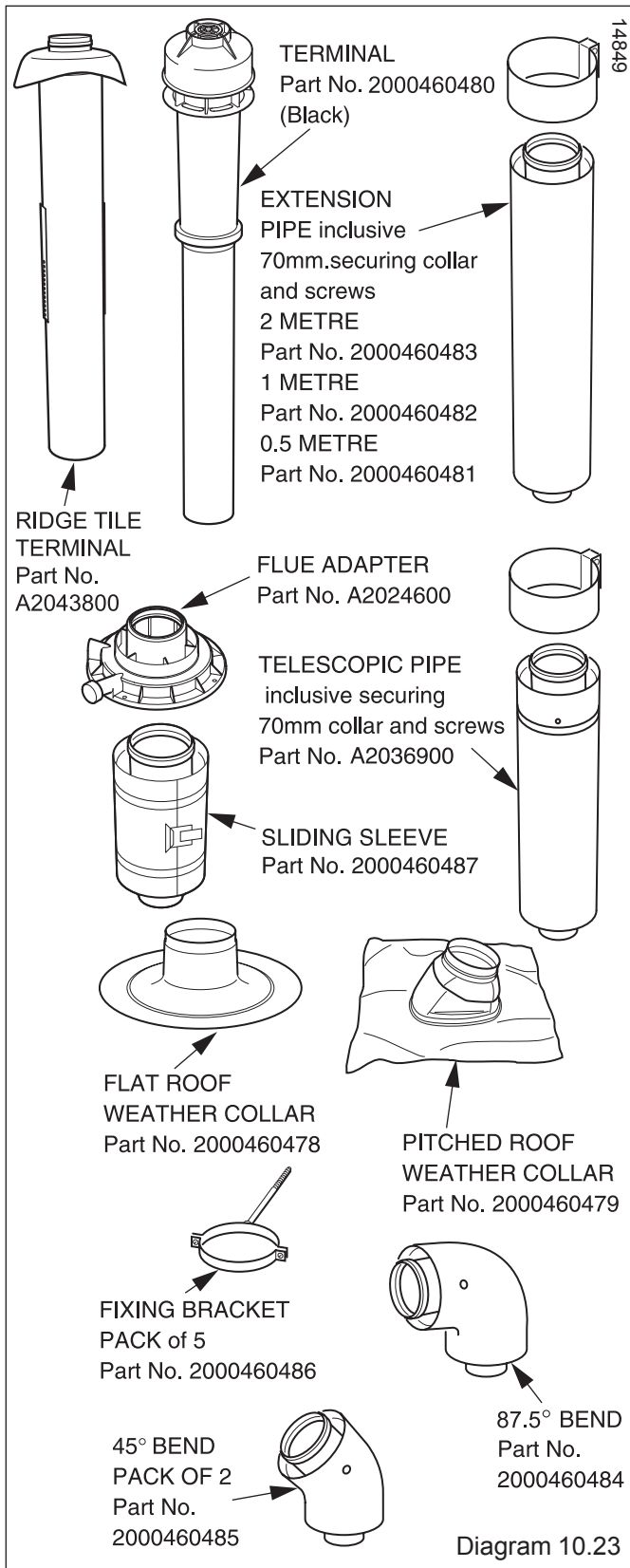

Diagram 10.22

10 Vertical - Flue Length, Preparation and Installation



Flue Installation

IMPORTANT:-

The flue seals are sensitive to mineral oil based lubricants. **Do not grease the seals.** If the seals do need to be lubricated **use only water.**

During the installation of the flue system, ensure that debris such as mortar, filings or swarf are cleared from the flue system before completion.

Long lengths of flues must be secured to the walls or ceilings they run against. Use at least one fixing bracket for every flue extension that is used.

After cutting inner flue tubes ensure that you de-burr and chamfer the male tube end to prevent damage.

Inspect the flue pipes before fitting and do not install damaged or dented flue components.

When assembling the flue system, ensure that the inner seals are not damaged, do not install a flue component with a damaged seal.

When fitting flue elbows ensure that they are fitted at the correct angle to avoid strain, this will ensure that the seal fits correctly preventing leakage.

Remove the top flue outlet cover secured with four screws, see diagram 10.4.

Refer to diagram 10.25 and secure the flue adapter in position on top of the boiler with four screws supplied, making sure the nib fits into the locating slot in the boiler casing to ensure correct orientation.

Secure the first extension pipe to the flue adapter with the securing collar supplied by positioning the collar centrally over the joint, then tighten the two screws on the securing collar, see diagram 10.26.

Fit more extension pipes as required using the collar and screws supplied with each extension pipe. To fit position the collar centrally over the joint, tighten the two screws on the securing collar. Using the holes provided in the securing collar drill and insert the two self tapping screws supplied, see diagram 10.27.

The rubber 'O' rings of each section should be lubricated prior to assembly.

When installing the flue it is recommended that it is supported every 2 metres and at every bend by a fixing bracket.

Project the rise of the flue pipe to roof level and cut a 150mm hole in the roof.

Flue Terminal Installation

(a) Pitched Roof

Fit the required pitched roof weather collar over the 150mm hole in the roof. Make good the tiling or slating around the collar incorporating the flashing of the weather collar. Position the angle cap over the weather collar in the correct orientation to attain the correct angle for your roof.

(b) Flat Roof

Fit the aluminium weather collar over the 150mm hole in the roof ensuring a weather tight seal.

From above carefully place the flue terminal through the weather collar.

Flue Terminal to Boiler Connection

Should the clearances above the boiler to roof not allow for extensions, it is permitted to cut the flue terminal ensuring the relationship of flue and air duct lengths are retained.

10 Vertical - Flue Length, Preparation and Installation

Ridge Tile Terminal

A ridge tile terminal is available - part no. A2043800, see diagram 10.24.
The installation of a ridge tile will be required. A suitable ridge tile is manufactured by: -
Aspect East Anglia Limited
The Old Mill
East Harling
NORWICH
NR16 2QW
Website: www.aspectroofing.co.uk
Contact: Chris Haythorpe
General Manager - Tile Division
Tel: 01953 717777 Fax: 01953 717164

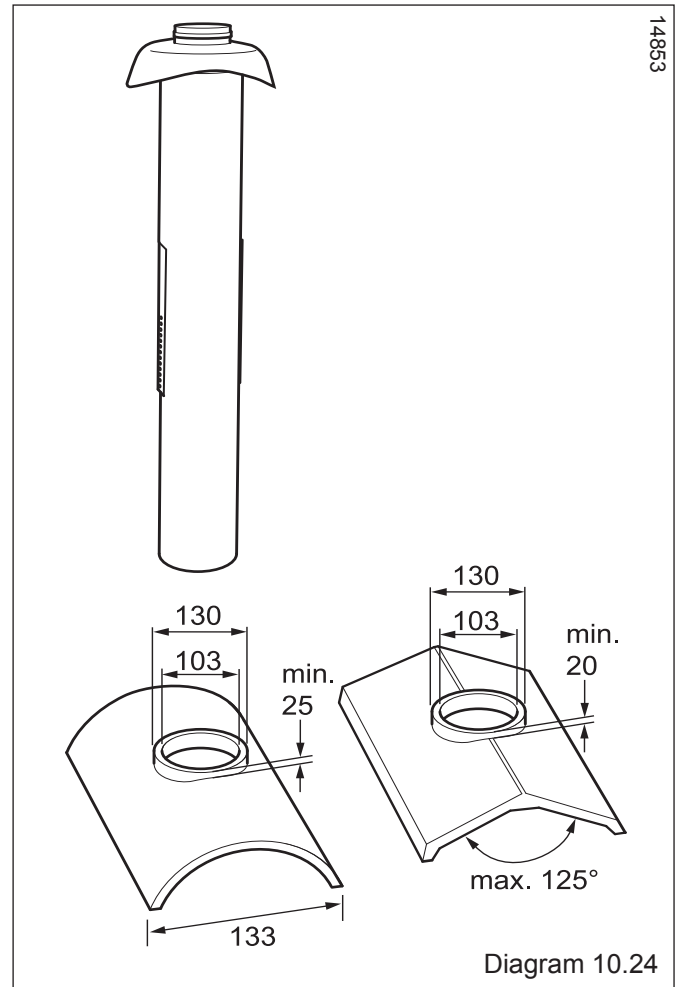

10 Vertical Flue Length, Preparation and Installation

Completion of Installation

With the flue terminal positioned in the roof the length of the final pipe can be determined. If a telescopic length cannot be used, then a standard flue length can be cut to make the correct length. Cut the flue to the desired length measuring from the 'O' ring end and discard the plain end of the tube. The cuts must be square and made free of burrs to allow correct assembly.

NOTE: The flue pipe is 10mm longer than the air pipe, see diagram 10.28.

Carefully push the terminal assembly upwards to allow room for fitting the final flue piece. Fit a fixing bracket to the terminal assembly. Pull the terminal assembly down and join to the flue system. Ensure that the terminal is making a weather tight seal on the weather collar. Secure the fixing bracket fitted to the terminal to the roofing struts or a purpose made batton.

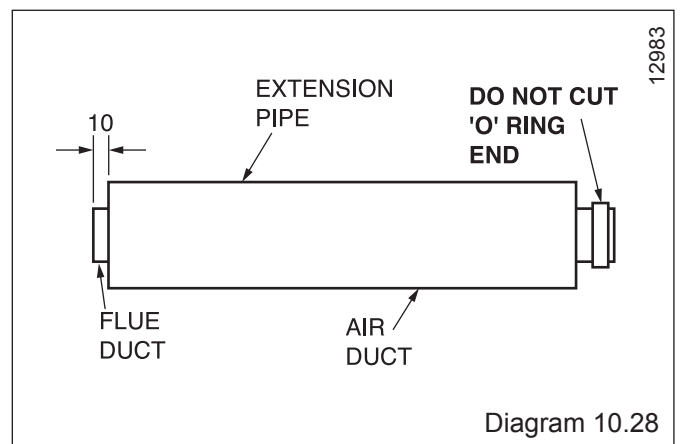
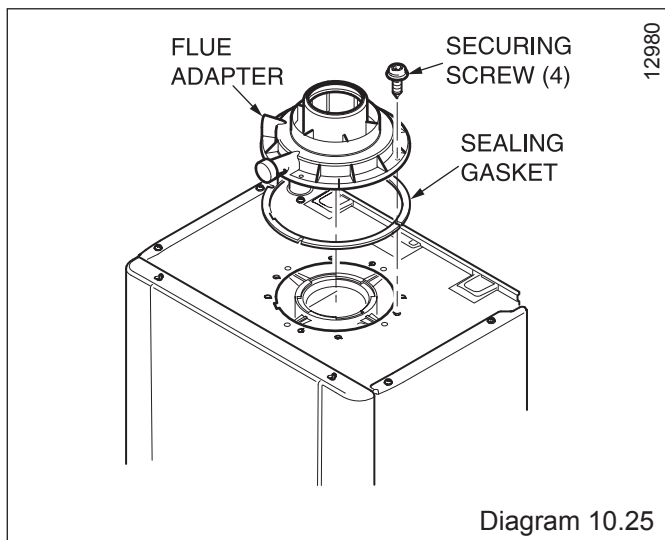
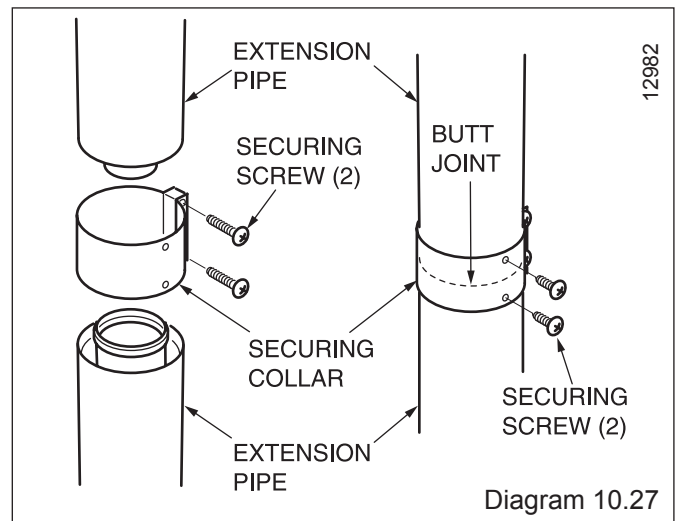
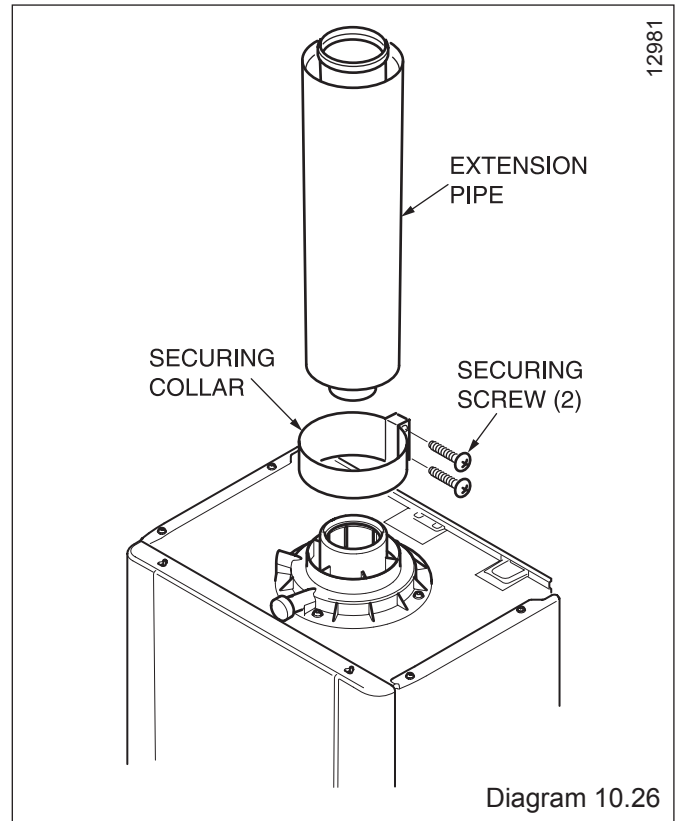

10 Twin Flue - Length, Preparation and Installation

15406

Secure long flue lengths (horizontal & vertical) to walls or ceiling at every joint or on straight flue runs at every joint and every metre flue run.

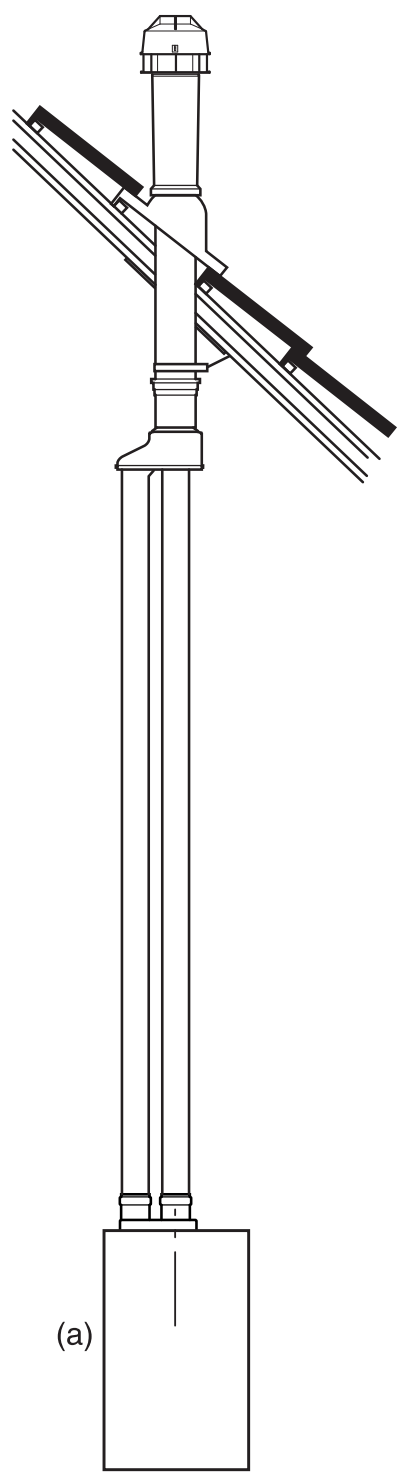

100 mm. APPROX.

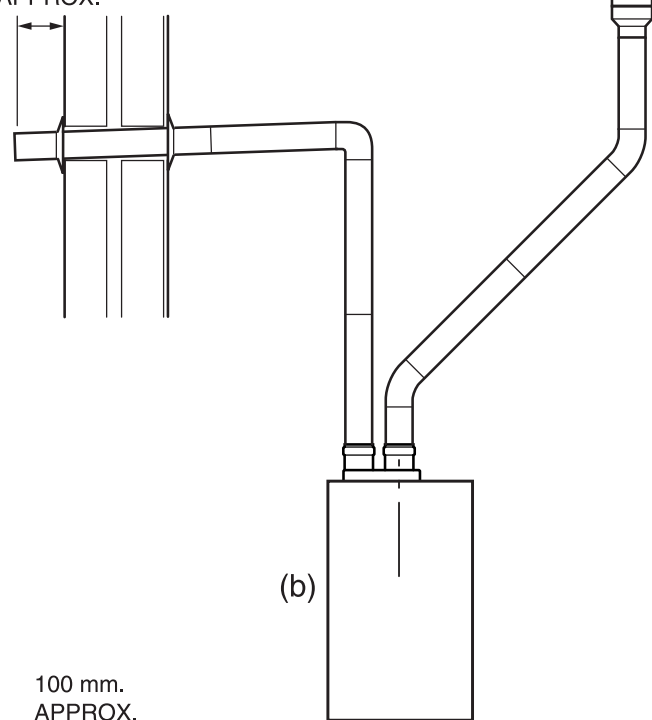

(b)

100 mm. APPROX.

$2\frac{1}{2}^\circ$
44mm/metre

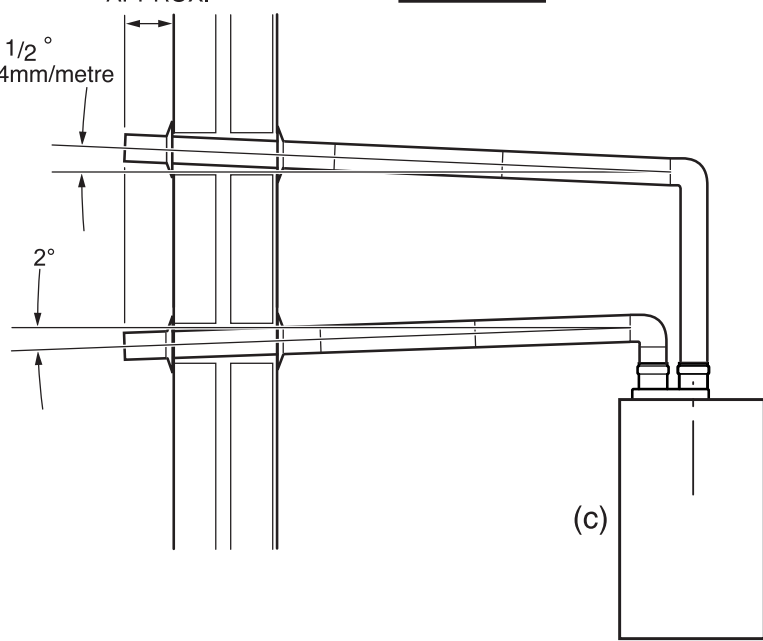

(c)

Diagram 10.29

10 Twin Flue - Length, Preparation and Installation

10.15 Twin flue length

The twin flue system is available as an option when the top horizontal or vertical flue system is not appropriate. The system can provide an independent horizontal air inlet and flue outlet, horizontal air inlet and vertical flue outlet or vertical air inlet and flue outlet via a concentric terminal. The system is made up from accessories, see diagram 10.30.

NOTE: The air and flue outlets do not have to be equal lengths. 2x45° bends can replace 1x90° bend if necessary. The maximum permitted combined (air inlet + flue outlet) flue length is 20 metres plus terminal assemblies. For each 90° or 45° x 2 bends fitted, the maximum flue length must be reduced by 1 metre, see diagram 10.29.

NOTE: When using 90° bends any horizontal run should be inclined by a minimum of 44mm/metre (2.5°) towards the boiler to facilitate condensate removal. Alternatively use 45° bends to avoid horizontal runs in the flue pipe.

Multiple Boiler Chimney Flue Length

The flue length must be calculated and installed according to the relevant standards EN 13384-1 and 2 (C43 flue systems only) with reference to the table below and the manufacturers instructions supplied.

The appliance maximum flue length must be included when calculating the overall design of the flue system.

Terminal Position

The clearances for a flue outlet are given in the "Flue Location and Ventilation" section.

In addition the horizontal air inlet must not be closer than 300 mm from a flue outlet on the same wall or 1200mm from an opposing flue outlet.

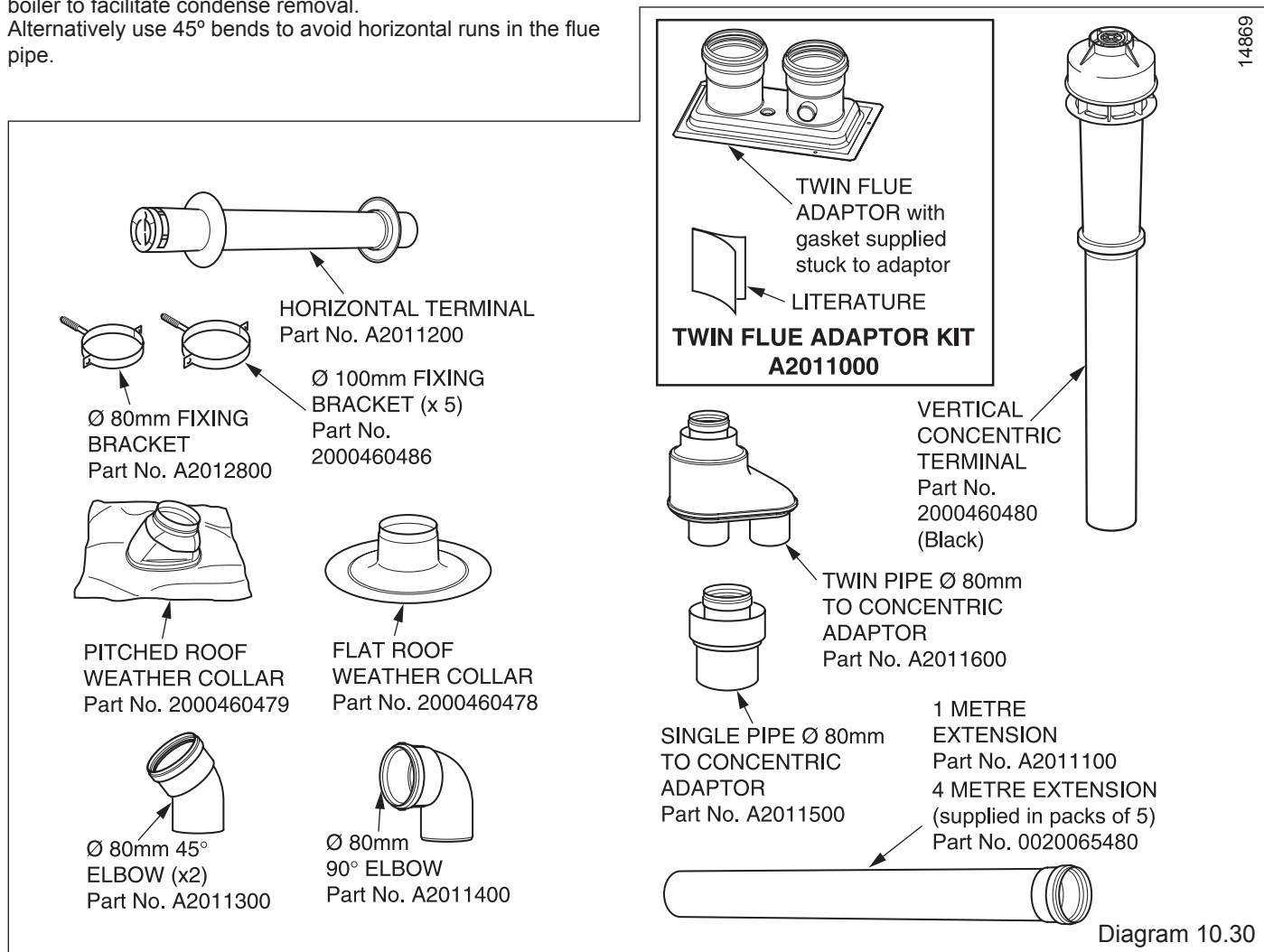

	Flexicom 12hx	Flexicom 15hx	Flexicom 18hx	Flexicom 24hx	Flexicom 30hx	Flexicom 35hx
Exhaust mass rate (g/s)						
At Min Thermal Load (40C°/30°C)	4.30	4.30	4.30	4.30	4.30	4.30
At Max Thermal Load (80C°/60°C)	5.54	6.91	8.33	11.17	14.10	16.39
Exhaust temperature (°C)						
At Min Thermal Load (40C°/30°C)	33.2	33.2	33.2	33.2	33.2	36.0
At Max Thermal Load (80C°/60°C)	55.8	58.3	63.0	73.3	87.4	84.0

10 Twin Flue - Length, Preparation and Installation

Installation Details

The parts available for a twin flue system installation are shown in diagram 10.30.

Boiler Connection

IMPORTANT: The flue seals are sensitive to mineral oil based lubricants. **Do not grease the seals.** If the seals do need to be lubricated **use only water.**

Remove the top flue outlet cover secured with four screws, see diagram 10.4.

Place the twin flue adaptor onto the outlet of the boiler with the air inlet to the left hand side, see diagram 10.31. Secure the adaptor to the top panel with the screws provided. Care should be taken when inserting the screw through the hole in adaptor top.

Air and Flue Pipe Installation

The air and flue pipes can now be built up from the boiler. The flue must be designed with a continuous fall towards the boiler. If using the horizontal flue pipe or 90° bends the pipe must be inclined at 44mm/metre (2.5°) minimum, see diagram 10.29. Alternatively if space allows, use 45° bends in place of 90° bends.

To avoid rain ingress to the air inlet terminal, it is good practice to aim the inlet downwards by approx 2° as rain can damage the boiler. The Flue outlet pipe must always run at 44mm/metre (2.5°) back to the boiler.

IMPORTANT:-

Long lengths of flues must be secured to the wall or ceiling it runs against. Use at least one fixing bracket on each flue joint used or on straight flue runs every joint and for every metre flue run.

Provision must be made in concealed boxing or ductwork that the flue joints can be inspected during annual servicing. The flue seals are sensitive to mineral oil based lubricants. **Do not grease the seals.** If the seals do need to be lubricated **use only water.**

Do not use the flue pipe to attach other pipes or equipment. If visible, advise the householder not to hang or clip items to flue pipes.

Do not stress the flue connections during the installation, this can damage the flue seals.

Horizontal Terminal Installation

NOTE: The air inlet terminal and the flue outlet terminals must never be installed on the opposite sides of a property. Termination must only be on the same wall or adjacent walls. When installed close together separated vertically, the air inlet must be fitted below the flue outlet terminal (see diagram 10.29).

With due consideration to terminal clearances mentioned in section 4.2 drill the one or two holes as required with a 90mm core drill.

Push the horizontal terminal through the wall allowing approx. 100mm to protrude outside.

Push a grey rubber wall seal onto either side of the wall ensuring that both wall seals are pushed up to the wall surface, see examples (b) and (c) diagram 10.29.

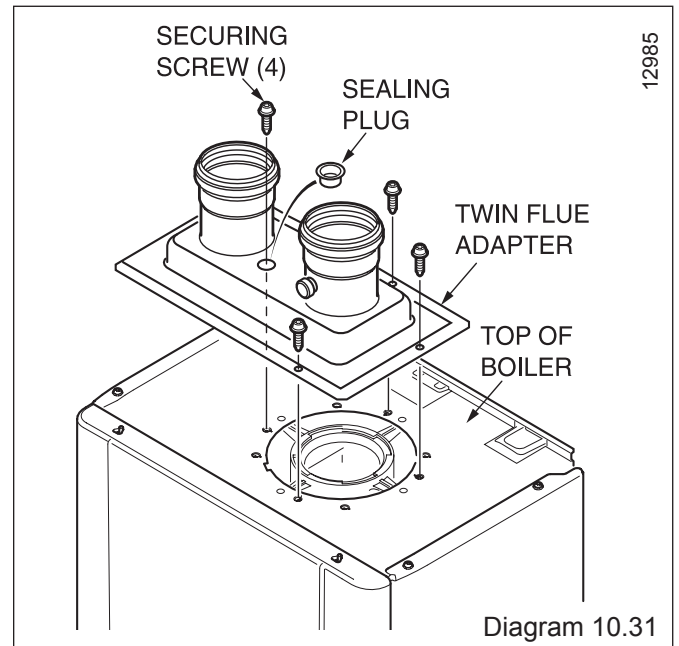

Vertical Terminal Installation

With due consideration to terminal clearances mentioned in Section 4.2, project the rise of the flue pipe to roof level and cut 150mm hole in the roof.

(a) Pitched Roof

Fit the required pitched roof weather collar over the 150mm hole in the roof. Make good the tiling or slating around the collar incorporating the flashing of the weather collar. Position the angle cap over the weather collar in the correct orientation to attain the correct angle for your roof. One way round gives a pitch of 25°-38° and the other gives 37°- 50°.

(b) Flat Roof

Fit the aluminium weather collar over the 150mm hole in the roof ensuring a weather tight seal.

Horizontal Pipes-Completion of Installation

Having built the pipe(s) from the boiler to the terminal(s), the length of the final pipe piece can be determined. Cut pipes at the opposite end to the 'O' ring seal making square and free from burrs. Push the horizontal terminal through the wall to engage the final pipe piece and pull back ensuring the grey wall seals are fully pulled up to the outside and inside wall faces.

Vertical Pipes-Completion of Installation

Refer to diagram 10.29.

For installation of (a), attach the twin pipe to concentric flue adaptor, part number A2011600, to the base of vertical terminal assembly. For installation of (b), attach the single pipe to concentric adaptor, part number A2011500, to the base of vertical terminal assembly.

With the vertical terminal assembly positioned in the roof, the length of the final pipe can be determined. Cut the flue to the desired length measuring from the 'O' ring seal end and discard the plain end of the tube. The cut end should be square and free from burrs. Carefully push the terminal assembly upwards to allow room for fitting the final flue piece(s). Fit a 100mm fixing bracket to the terminal assembly Part No2000460486. Pull the terminal assembly down and join to the flue system. Ensure that the terminal is making a weather tight seal on the weather collar. Secure the fixing bracket fitted to the terminal to the roofing struts or a purpose made batton.

10 Plume Management Kit

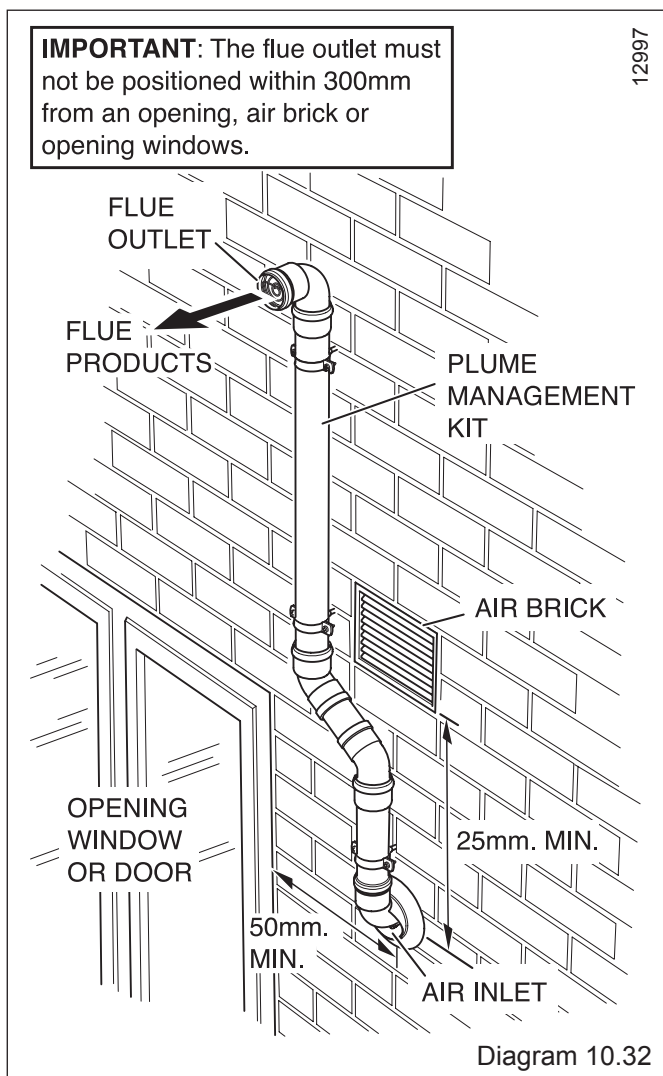

10.16 Plume Management Kit

The Plume Management Kit: Part No. A2044100 (white) or A2044000 (black) can be used to overcome many site issues.

The Plume Management Kit will fit to the Top Horizontal Telescopic, Rear Horizontal Telescopic and Standard Horizontal Flue. This enables the flue products to exhaust further away from the boiler, thereby reducing the impact of pluming.

NOTE: The flue air inlet can be sited closer to doors, opening windows and air bricks, than stated in section 4.2, see diagram 10.32.

The maximum length of the Plume Management Kit must NOT exceed 6m with a horizontal concentric flue length of 2m max.

For each 90° bend or 2 x 45° bends the maximum length of the Plume Management Kit must be reduced by 1m.

For more information contact Glow-worm, refer to page 2.

The Plume Management Kit is supplied with installation instructions.

Refer to BS5546 or BS6798 for advice on disposal of boiler condensate.

10 Deflector Flue Terminal Kit

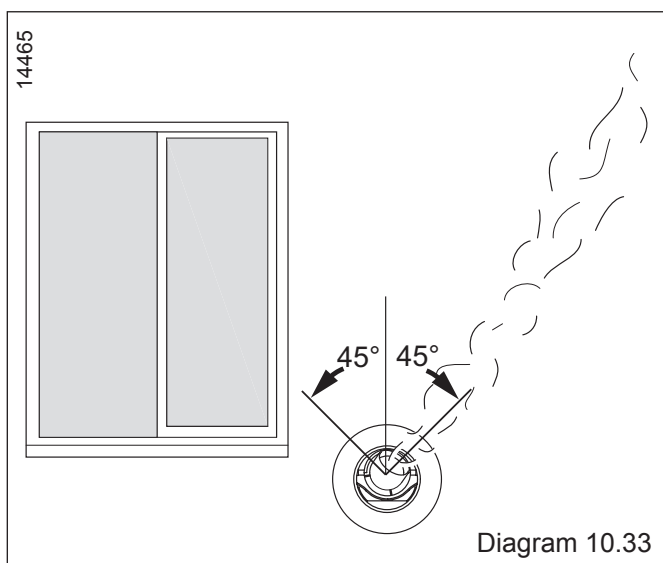

10.17 Deflector Flue Terminal Kit

The terminal kit fits onto the telescopic and standard horizontal flue, see diagram 4.1 for kit contents.

The kit is also supplied with installation instructions.

NOTE: The deflector flue terminal kit can be fitted after the boiler and flue have been installed.

The deflector part of the deflector flue terminal can be rotated 45° to allow pluming away from openings, people, cars, windows etc., see diagram 10.33.

Should the deflector terminal be positioned under a soffit or horizontal surface, it is allowed to project the flue 600mm from the wall, to allow the discharge of flue gases produced into free air.

IMPORTANT: Do not fit the deflector flue terminal with the deflector positioned downwards.

11 Electrical Connection

WARNING: This appliance must be earthed.

- This appliance must be wired in accordance with these instructions. Any fault arising from incorrect wiring cannot be put right under the terms of the Glow-worm guarantee.
- All system components must be of an approved type. Electrical components have been tested to meet the equivalent requirements of the BEAB.
- Do not interrupt the mains supply with a time switch or programmer.
- Connection of the whole electrical system and any heating system controls to the electrical supply must be through a common isolator.
- Isolation should preferably be by a double pole switched fused spur box having a minimum contact separation of 3mm on each pole. The fused spur box should be readily accessible and preferably adjacent to the boiler. It should be identified as to its use.
- A fused three pin plug and shuttered socket outlet may be used instead of a fused spur box provided that it is not used in a room containing a fixed bath or shower.
- The boiler is suitable for installation in bathroom zones 2 and 3.

11.1 Electrical Wiring

Remove the electrical cartridge from the fittings pack.

Remove the securing screw to open the cartridge, see diagram 11.1.

NOTE: There are two screws supplied loose in the electrical cartridge, these will be required to secure the cartridge into the electrical interface housing.

Slacken the cable strain relief screws in the electrical cartridge, see diagram 11.1.

Route the mains supply and system cables through the strain relief and connect to the relevant plug, see diagram 11.2.

11.2 Pump Wiring

Ensure that a separate pump supply cable is routed through the strain relief and connected to the relevant plug, see diagram 11.2.

Slacken the cable strain relief and route the pump electrical supply cable and connect as shown in diagrams 11.1 and 11.2.

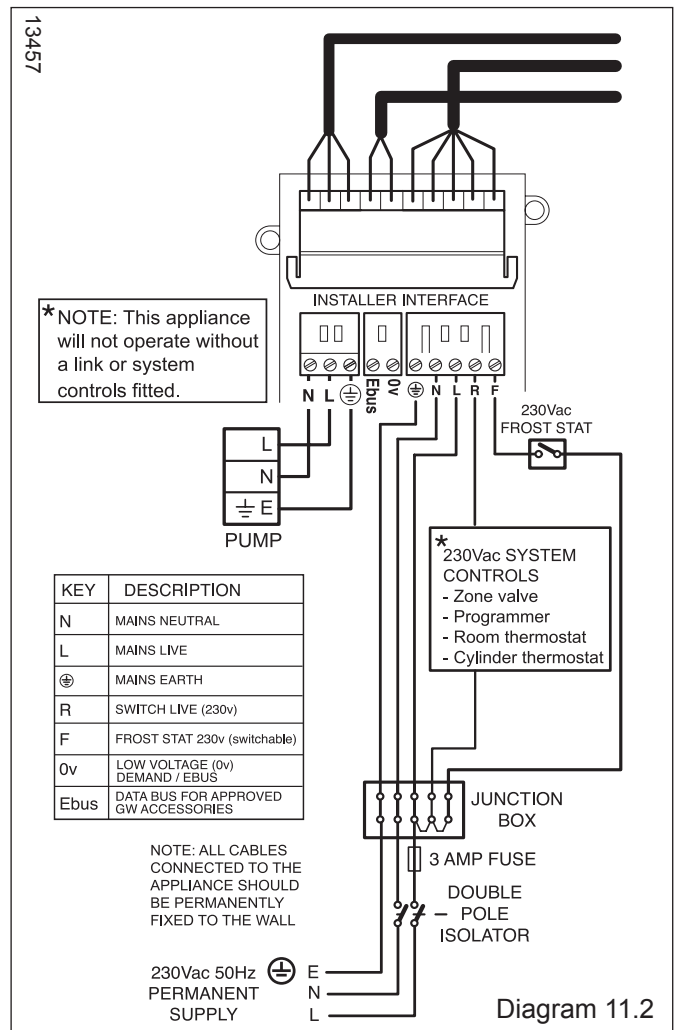
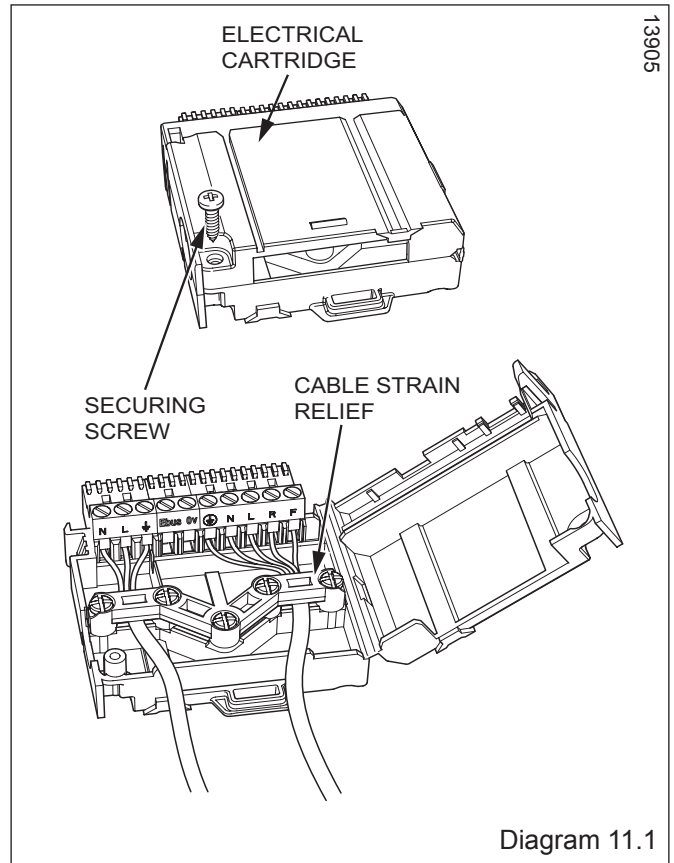

11 Electrical Connection

11.3 Electrical Cartridge Securing

Close the cartridge and secure with the previously removed screw.

Push the electrical cartridge into the interface housing on completion of the wiring, see diagram 11.3.

Secure with the two cartridge retaining screws provided in the cartridge body.

11.4 Electrical Connections - Testing

Carry out preliminary electrical system checks as below:

1. Test insulation resistance to earth of mains cables.
2. Test the earth continuity and short circuit of cables.
3. Test the polarity of the mains.

NOTE: If you require to test the appliance refer to section 14.

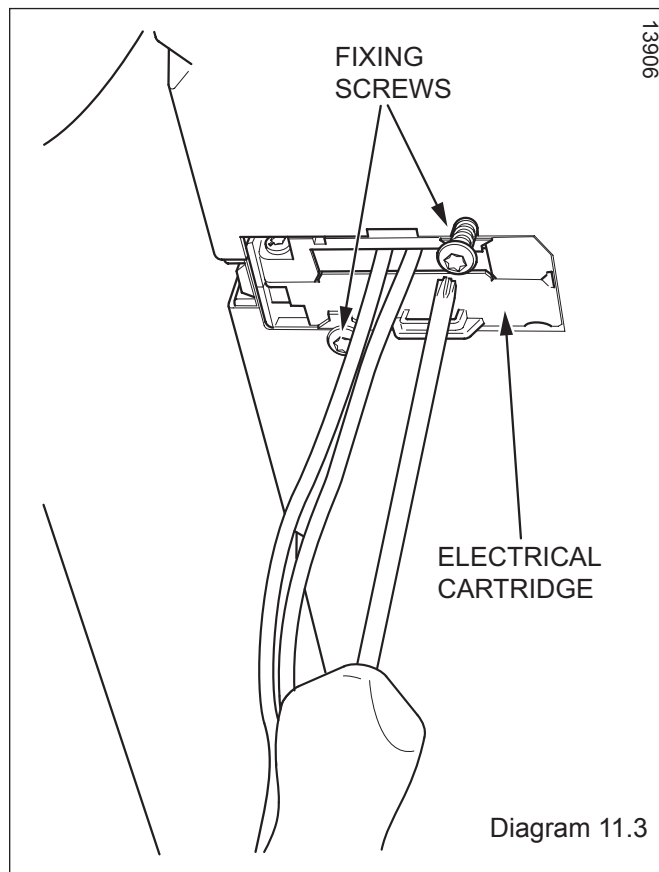

12 Commissioning

IMPORTANT: At the time of commissioning, complete all relevant sections of the Benchmark Checklist located in the centre pages of this document.

12.1 Preliminaries - All Systems

DO NOT operate the boiler without water.

The commissioning should be carried out by a **competent person** approved at the time by the Health and Safety Executive in accordance with the current issue of BS6798. Make sure that the system has been thoroughly flushed out with cold water and that all cleanser, if used, has been removed.

With the gas service isolation valve closed, with no demand from any external controls and the power supply to the boiler switched off, test for gas soundness and purge air from the gas supply.

12.2 Filling the Heating Circuit

With the gas service isolation valve closed and with no demand from any external controls.

1. Fill the heating system.
Sealed system only - fill the system to a pressure of 1.0bar.
2. Vent all air from the system - repeat as necessary until the system is full and all the air has been vented.

12.3 Gas Supply

The gas valve is factory set for natural gas (G20) and should need no adjustment. Turn on the gas supply at the isolation valve, see diagram 12.1. Check the supply pressure at the pressure test point is 20mbar.

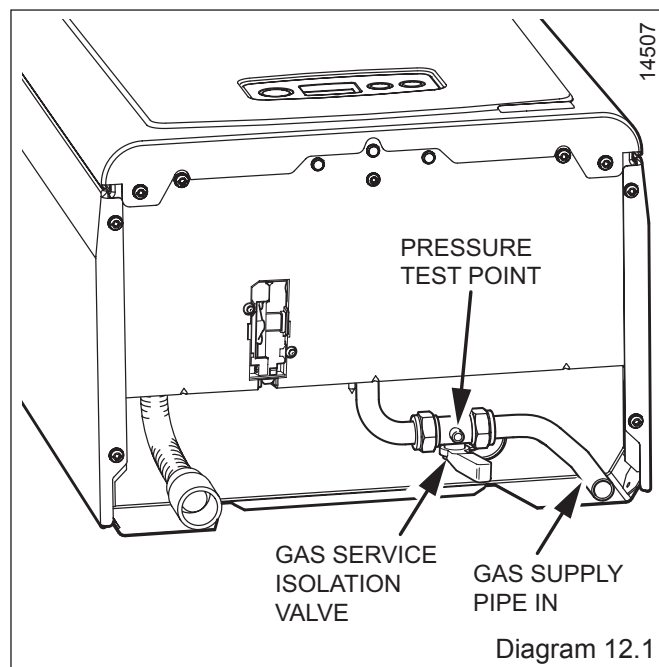

12 Commissioning

14513

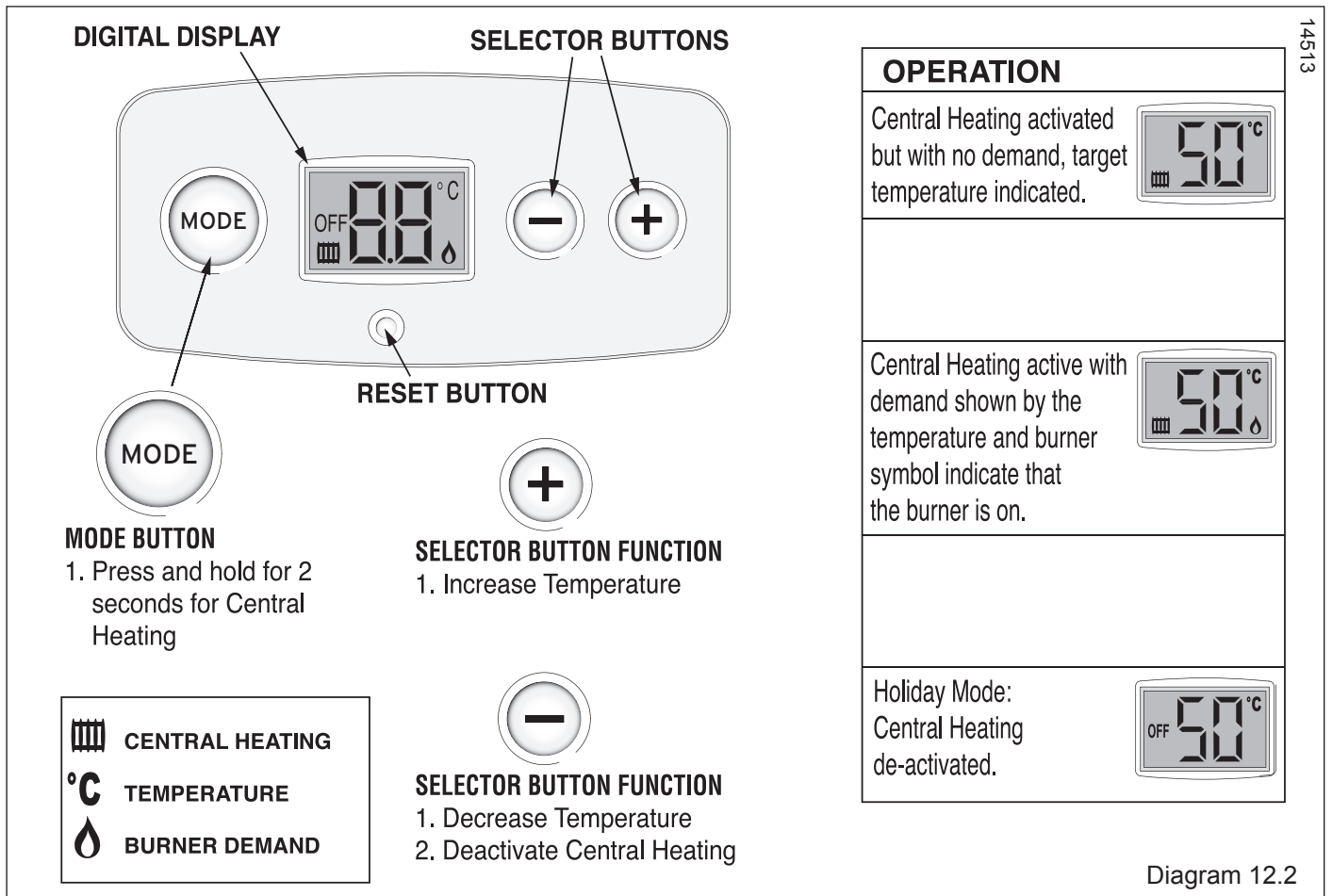

Commissioning should only be carried out by a **competent person** approved at the time by the Health and Safety Executive.

12.4 Initial Lighting

NOTE: The combustion for this appliance has been checked, adjusted and preset at the factory for operation on natural gas (G20) as defined on the appliance data label.

Do not adjust the Gas/Air ratio valve.

No measurement of the combustion is necessary, having checked :

- the appliance has been installed in accordance with the instructions.
- the integrity of the flue system and flue seals.
- that all internal/external controls are calling for heat.
- the gas service isolation valve, diagram 12.1, is open.

DO NOT operate the boiler without water.

The lighting procedure of the boiler is fully automated.

Refer to diagram 12.2.

- With no demand from any external controls, switch on the electrical supply to the boiler.
- Open the gas service isolation valve, see diagram 12.1.
- The appliance will enter a self checking routine then the fan should start and the ignition will commence.

The boiler, if necessary, will automatically repeat the ignition sequence a further 4 times.

- If the burner fails to ignite "F1" will be displayed, initially, this may be due to air in the gas supply line.
- Once the system has been purged of air. Press and hold the " Mode " button of the boiler user controls for 2 seconds, the Central Heating symbol, will flash. Use the "SELECTOR" buttons to adjust CH temperature.

After 10 seconds of inactivity the display will reset to indicate the water temperature.

- Turn ON your external controls and select the room temperature required.

The boiler will operate automatically.

NOTE: The display will indicate the Heating system water temperature or a fault code if in a fault condition.

12.5 Check the Gas Inlet Pressure & Gas Rate

The supply from the governed meter must be of adequate size to provide a steady inlet working pressure of 20mbar (8in wg) at the boiler. On completion, test the gas installation for tightness using the pressure drop method and suitable leak detection fluid, purge as necessary.

NOTE: Due to the modulating operation of the boiler and the need to check the gas inlet pressure and measure the gas rate at maximum rate, it will be necessary to force it to maximum.

Press the "reset" button on the controls fascia, release and immediately press and hold in the "+" button. After approximately 5 seconds "Hi" will be displayed. Pressing the mode button when "Hi" is selected will force the boiler to maximum rate, the display will flash between "Hi" and the "default display" this will indicate the boiler has been forced to maximum.

Operational Gas Inlet Pressure

With ALL other gas appliances operating, check the operational supply pressure at the gas service isolation valve test point, see diagram 12.1.

The nominal supply pressure for Natural Gas (G20) is 20mbar. Turn the taps and appliances off, then disconnect the pressure gauge.

12 Commissioning

Additionally the safe nominal maximum heat input of the appliance can be achieved at an inlet pressure down to 15mbar.

NOTE: The **BURNER PRESSURE** cannot be measured.

Gas Rate

Make sure that ALL other gas burning appliances and pilot lights are off.

Check the gas rate using the gas meter test dial and stop watch, at least 10 minutes after the burner has lit.

The approximate maximum gas rates are:

APPROXIMATE GAS RATES		
MODEL	NATURAL GAS G20	
	m3/h	ft3/h
12hx	1.28	45
15hx	1.60	56.5
18hx	1.93	68
24hx	2.58	91
30hx	3.26	115
35hx	3.8	134

14249

12.6 Range Rating

The boilers are fully modulating, therefore it is not necessary to range rate them, however, if desired, you can adjust the boiler in 1kW increments between 10 and maximum output of your appliance, as follows:

- Press and hold the 'MODE' and "+" button for 5 seconds. The display will change to flashing '0'.
- Use the '+' or '-' button to scroll to 96.
- Press and hold 'MODE' 5 seconds to confirm.
- The display now shows a flashing 'd. 0'.
- The part load setting is displayed in kW. Press 'MODE' the max rate will be indicated, to change the value to the desired setting, use the '+' or '-' button.
- Press 'MODE' for 5 sec to confirm the new setting has been saved.
- Press and hold 'MODE' and "+" to exit.

kW	m3/hr	ft3/hr	kW	m3/hr	ft3/hr
35	3.7	131	22	2.3	81.2
34	3.6	127	21	2.2	77.7
33	3.5	124	20	2.1	74.2
32	3.4	120	19	2.0	70.6
31	3.3	117	18	1.9	67.1
30	3.2	113	17	1.8	63.6
29	3.1	109.5	16	1.7	60.0
28	3.0	106	15	1.6	56.5
27	2.9	102.4	14	1.5	53.0
26	2.8	98.9	13	1.4	49.5
25	2.6	91.8	12	1.3	45.9
24	2.5	88.3	11	1.2	42.4
23	2.4	84.8	10	1.12	38.9

12.7 Heating System

Ensure that the external controls are calling for heat.

Fully open all radiator valves, flow control valve and bypass valve if fitted.

Balance the radiators as required and if fitted adjust flow control valve to give the required system differential. Turn off all radiators that can be shut off by the user and check to see if less than the maximum differential allowed of 20°C can be achieved across flow and return.

NOTE: Allow the system to reach maximum temperature then switch off the boiler by isolating from the electrical supply.

Drain the entire system rapidly whilst hot, using the drain tap at the lowest part of the system. Fill and vent the system as described previously in section 12.2

Lock or remove the handle from controls valve, if fitted.

Adjust the boiler temperature controls and any system controls to their required settings.

12.8 Completion

Ensure that the magnetic lighting instruction label is placed on the surface of the boiler casing.

GB: It is a requirement that the "Benchmark" Installation Commissioning and Service Record is completed and left with the user.

IE: it is necessary to complete a "Declaration of Conformity" to indicate compliance to I.S.813. An example of this is given in the current edition of I.S.813.

12.9 Instruct the User

- Demonstrate, then instruct the User about the lighting procedure and heating system controls operation.
- Advise that to ensure the continued efficient and safe operation of the boiler it is recommended that it is checked and serviced at regular intervals. The frequency of servicing will depend upon the installation conditions and usage, but in general, once a year should be enough.
- Draw attention, if applicable, to the current issue of the Gas Safety (Installation and Use) Regulations, Section 35, which imposes a duty of care on all persons who let out any property containing a gas appliance in the UK.
- The user shall not interfere with or adjust sealed components.
- It is the Law that any servicing is carried out by a **competent person** approved at the time by the Health and Safety Executive.
- Advise the user that, like all condensing boilers this appliance will produce a plume of condensation from the flue terminal in cool weather. This is due to the high efficiency and hence low flue gas temperature of the boiler.
- Advise the user of the precautions necessary to prevent damage to the system, boiler and the building, in the event of the heating system being out of use during frost or freezing conditions.
- Advise the user that the permanent mains electrical supply SHOULD NOT be switched off, as the built in frost protection and pump saver program will not operate.
- Advise the User if the mains electricity and gas are to be turned off for any long periods during severe weather, it is recommended that the whole system, including the boiler, should be drained to avoid the risk of freezing.
- NOTE: Sealed System:** Contact your installation/servicing company as draining, refilling and pressurising MUST be carried out by a **competent person** approved at the time by the Health and Safety Executive.
- Leave these instructions and the 'Benchmark' Installation, Commissioning and Service Record with the user.

13 Servicing

IMPORTANT NOTES:

1. To ensure the continued efficient and safe operation of the boiler it is recommended that it is checked and serviced at regular intervals. The frequency of servicing will depend upon the particular installation and usage, but in general once a year should be enough.
2. It is the Law that any servicing is carried out by a **competent person** approved at the time by the Health and Safety Executive.
3. Before commencing with a service or replacement of parts the boiler should be isolated from the electrical supply and the gas supply should be turned off at the gas isolation valve.
4. When replacing a part on this appliance, use only spare parts that you can be assured conform to the safety and performance specification that we require. Do not use reconditioned or copy parts that have not been clearly authorised by Glow-worm.
5. If any electrical connections have been disconnected and after their connection, checks to the earth continuity, polarity, short circuit and resistance to earth must be repeated using a suitable multimeter, as described in section 14.
6. After servicing, complete the relevant Service Interval Record section of the Benchmark Checklist located in the centre pages of this document.

General Inspection

Prior to, during servicing and after any maintenance or changed parts, the following must be checked.

- The integrity of the flue system and flue seals.
 - The integrity of the appliance combustion circuit and relevant seals.
 - Electrical, gas and water connections.
 - System pressure.
 - the combustion performance, refer to the following procedure.
 - The operational gas inlet pressure and gas rates, refer to the commissioning section paragraph 12.5.
- Correct any fault before continuing.

COMPETENCY TO CARRY OUT THE CHECK OF COMBUSTION PERFORMANCE

NOTE: BS 6798: 2009 Specification for installation and maintenance of gas-fired boilers of rated input not exceeding 70kW net advises that:

- The person carrying out a combustion measurement must be assessed as competent in the use of a flue gas analyser and the interpretation of the results.
- The flue gas analyser used should be one meeting the requirements of BS7927 or BS-EN50379-3 and be calibrated in accordance with the analyser manufacturers' requirements.
- Competence can be demonstrated by satisfactory completion of the CPA1 ACS assessment, which covers the use of electronic portable combustion gas analysers in accordance with BS 7967, parts 1 to 4.
- Ensure that the gas analyser is set to the correct fuel setting.
- Press and hold the " Mode " button of the boiler user controls for 2 seconds, the Central Heating symbol,  will flash, refer to commissioning section. The boiler should fire automatically.

NOTE: Safe combustion can only be verified by measuring CO/CO₂ ratio. This must not exceed the value shown in the table below.

G20 BURNER % CO ₂			
MODEL	CHECK	SETTING	CO/CO ₂ ratio
All MODELS	8.8 to 9.8	9.2 +0.3 - 0.3	0.004

COMBUSTION CHECK AND SETTING THE AIR/GAS RATIO VALVE

- Remove the front casing panel, see diagram 13.2 and hinge down the control box. Taking care not to touch any internal components, proceed as follows:
- Connect the CO₂ combustion analyser to the relevant test point, see diagram 13.1.

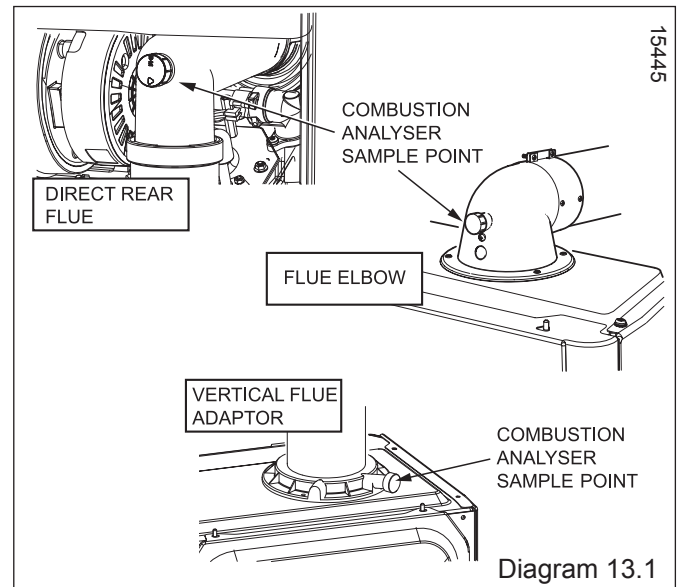

Diagram 13.1

1. Maximum Rate Check and Adjustment

NOTE: To verify the maximum gas rate CO₂ setting the appliance must be checked at the maximum rate first. Press the "reset" button on the controls fascia, release and immediately press and hold in the "+" button. After approximately 5 seconds "Hi" will be displayed. Pressing the mode button when "Hi" is selected will force the boiler to maximum rate, the display will flash between "Hi" and the "default display" this will indicate the boiler has been forced to maximum. Wait until the CO₂ value is stable and check that the value is within the range specified in table in the "check" column.

If the combustion reading is not within the acceptable values AND the integrity of the complete flue system and combustion circuit seals have been verified and the inlet gas pressure (and gas rate) have been verified, then, it will necessary to adjust the combustion rate of the appliance.

NOTE: Adjustment is made by turning the gas valve throttle an 1/8 of a turn, waiting 1 minute to allow the appliance to stabilise before checking or making further adjustments.

13 Servicing

- Rotate the “throttle”(anti-clockwise to increase), to the required CO₂, refer to diagram 13.4 and the “SETTING” column in the table.
- Exit the forced rate function, press the “mode” and “+” buttons simultaneously, this will reset the boiler to the default display. Now proceed to check the minimum rate adjustment.

2. Minimum Rate Check and Adjustment

- Now check the minimum gas rate CO₂ setting: Press and release the “reset” button on the controls fascia, then immediately press and hold in either of the “+” buttons. After approximately 5 seconds “Hi” will be displayed. Pressing the “+” or “-” buttons will toggle between “Hi” and “Lo”. Press the mode button when “Lo” is selected, this will force the boiler to minimum rate and the display will flash “Lo”, indicating the boiler is operating at minimum.
- Wait until the CO₂ value is stable and check that the value is within the range specified in table in the “check” column. If adjustment is necessary, proceed as follows:
NOTE: Adjustment of the CO₂ at minimum rate is very coarse and should not be adjusted more than an 1/8 of a turn at a time. Wait 1 minute to allow the appliance to stabilise before checking or making further adjustments.
- Gradually rotate the “offset adjustment” (anti-clockwise to decrease) to the required CO₂, refer to diagram 13.4 and the “SETTING” column in the table.
- Exit the minimum rate function, press the “mode” and “+” buttons simultaneously, this will reset the boiler to the default display.

3. Re-Check CO₂ and check the CO/CO₂ combustion ratio.

- Re-check the maximum and minimum CO₂ values to ensure that they are within the “setting” limits in the table then check the CO/CO₂ combustion ratio does not exceed the value in the CO/CO₂ column of the table. If the CO/CO₂ ratio exceeds the value in the table, a complete servicing of the appliance will be necessary, refer to section 13.1. If the CO₂ and the CO/CO₂ ratio falls within the tolerances quoted, exit the function press the “mode” and “+” buttons simultaneously, this will reset the boiler to the default display. Remove the analyser probe and replace the cap on the sampling point, replace the controls fascia, inner and front casing panels.
- IMPORTANT:** Remember to replace the sample point cap on completion of the test.

GAS RATE CHECK

Check the gas rates as described in the commissioning section.

COMPLETION

If it is not possible to achieve the required results for either the combustion or gas rates, it will be necessary to complete a full service of the appliance and then repeat the combustion check procedure. If after servicing and adjustment of the appliance the combustion values are still unacceptable and after further remedial work has been carried out, the appliance must be disconnected until the CO/CO₂ ratio is acceptable. Advice can be sought from the Glow-worm Technical Helpline.

13.1 Servicing

NOTE: If the Combustion CO₂, CO/CO₂ ratio & Gas rate checks did not require adjustment then it will not be necessary to complete a full service. All routine servicing requirements can be achieved by the removal of the front panel, see diagram 13.2. Position the control box into the service position, see diagram 13.3.

Before commencing with a service or replacement of parts. The boiler should be isolated from the electrical and gas supplies.

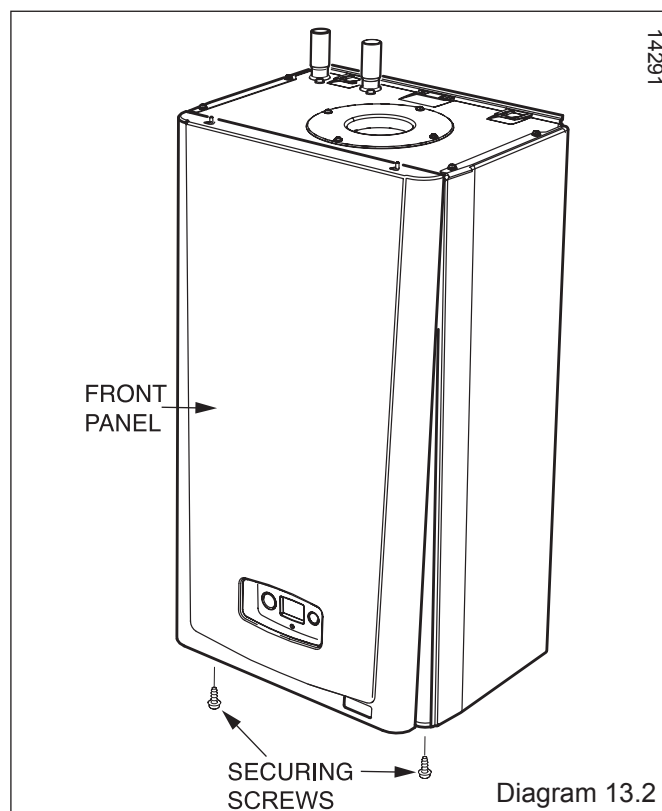

Diagram 13.2

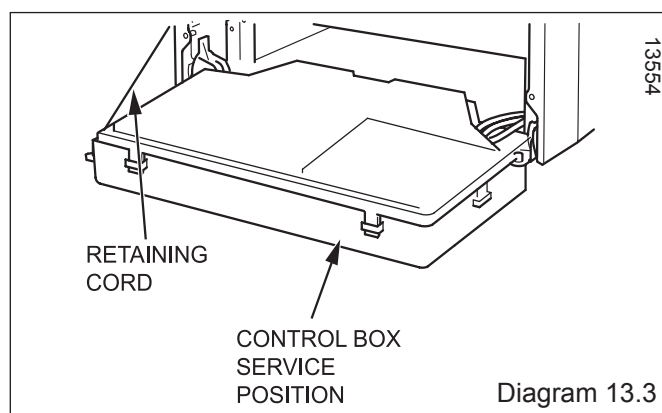

Diagram 13.3

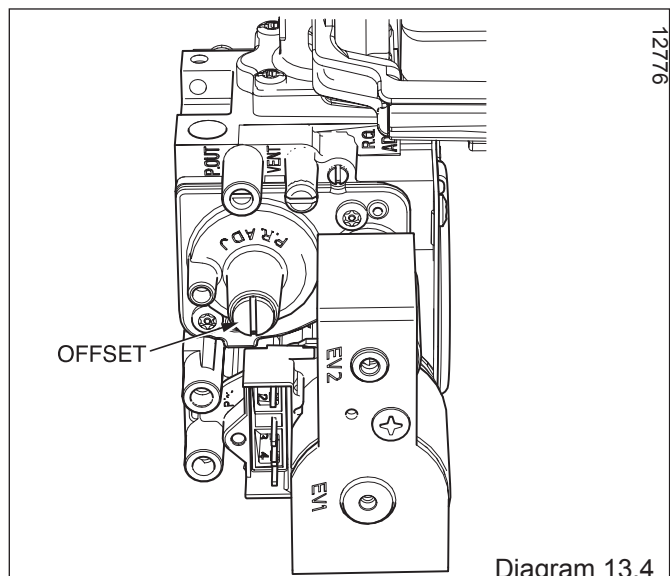

Diagram 13.4

13 Servicing

13.4 Spark Electrode

NOTE: If the functional checks did not indicate poor combustion then it is not necessary to service this component.

Ease the securing clips away from the sump to release the retaining catch then push the flue hood up to disengage from the sump, see diagram 13.5.

To remove, swivel flue hood 90° and pull down and out, see diagram 13.5.

Check seal for wear or damage and replace if necessary.

IMPORTANT: Do not allow fixings, nuts, screws, etc. to fall into the open flue hood sump, use a temporary cover whilst removing any parts.

Disconnect the spark electrode plug and earth lead. Remove the two securing screws and withdraw the spark electrode carefully from the combustion chamber, see diagram 13.6.

Inspect the tips for damage.

Clean away any debris and check the spark gap is 4mm.

Check the electrode gasket for signs of damage and replace if necessary.

13.5 Burner

NOTE: If the functional checks did not indicate poor combustion then it is not necessary to service this component.

Disconnect the gas supply at the gas valve and electrical connections, see diagram 13.7.

The Silencer (front) is a push fit, so there is no need for tools to remove or fit, see diagram 13.8.

Release the igniter unit support bracket, see diagram 13.9.

Remove the fan retaining bracket.

To ease removal of the securing nut from the fan retaining bracket, a flat bladed screwdriver can be used in the position shown and gently levered down as indicated, see diagram 13.10.

Remove the fan and gas valve assembly.

The silencer (rear) is a push fit so no tools are required for its removal or fitting, see diagram 13.11.

Check the spark electrode gap is 4mm. Clean and adjust as necessary, see diagram 13.6.

It should not be necessary to remove the spark electrode from the burner during servicing.

Remove the flanged nuts and studs that secure the burner, note that two studs at the rear also hold the fan clamping bracket, see diagram 13.12.

Clean the burner with a soft brush taking great care not to damage the surface of the burner. **DO NOT** use wire or sharp instruments to clean the mesh of the burner.

NOTE: The burner gasket should be inspected but will not need replacing unless there are signs of wear or damage.

Follow the tightening sequence when re-fitting the burner, see diagram 13.12.

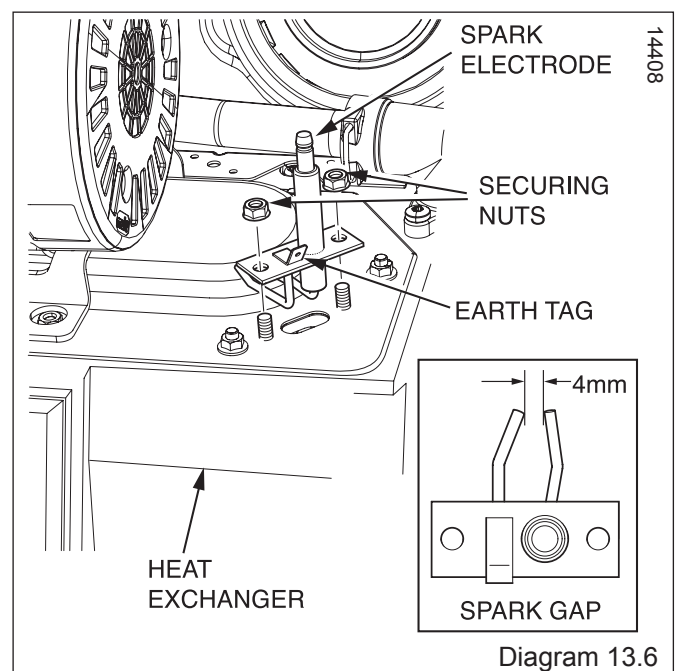
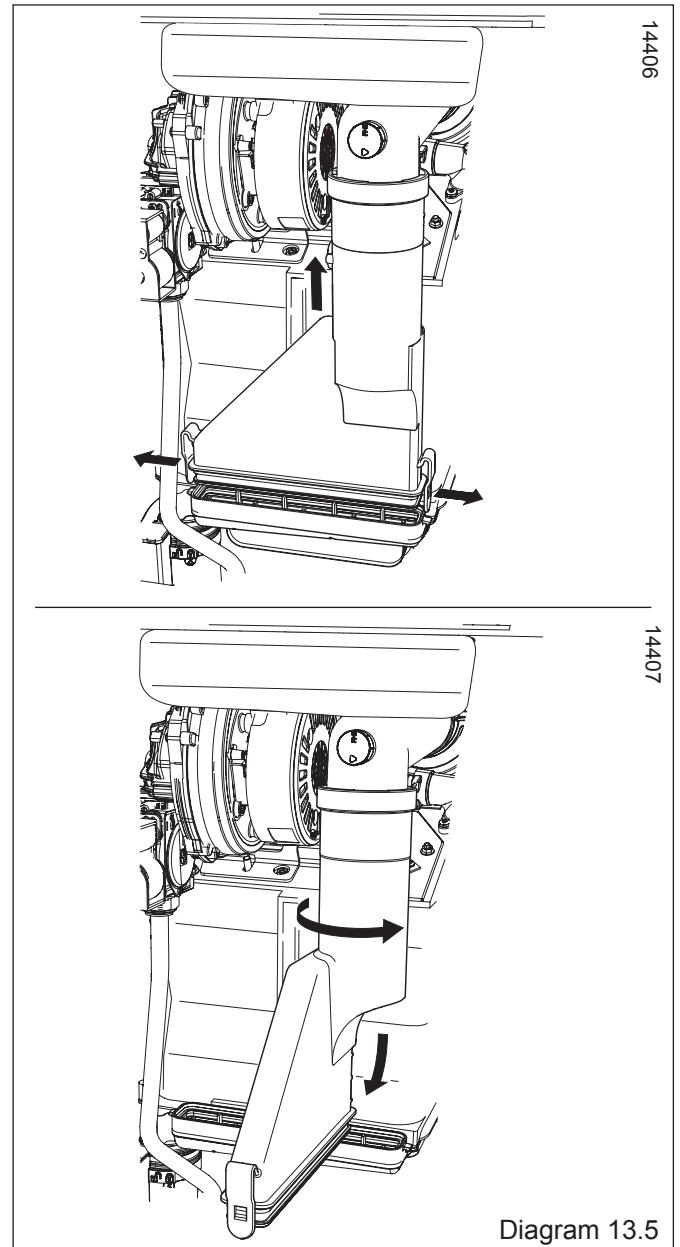

13 Servicing

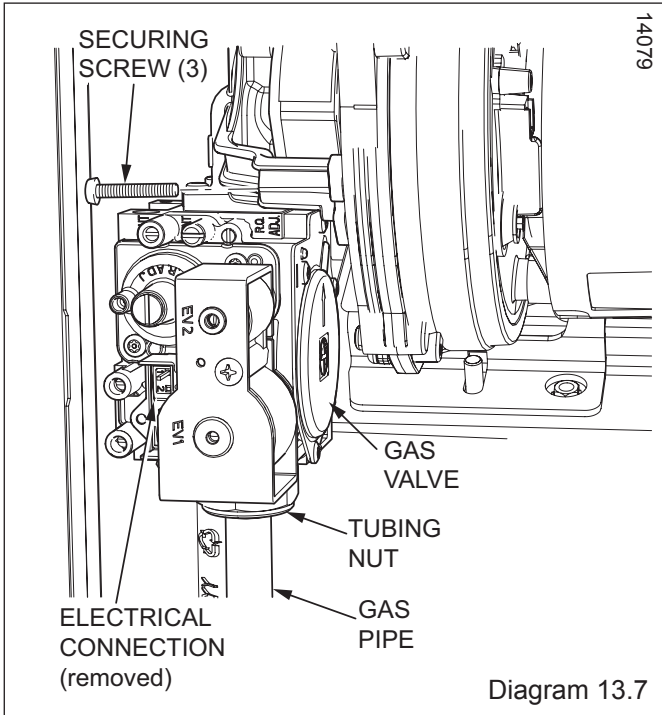

Diagram 13.7

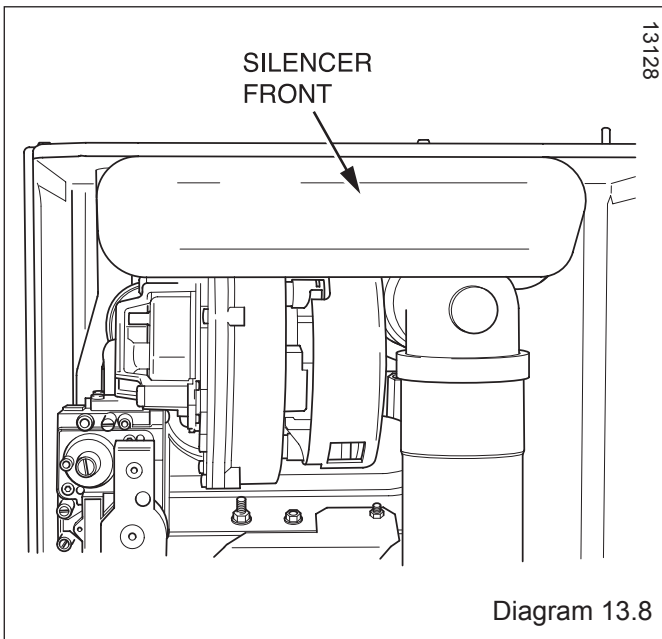

Diagram 13.8

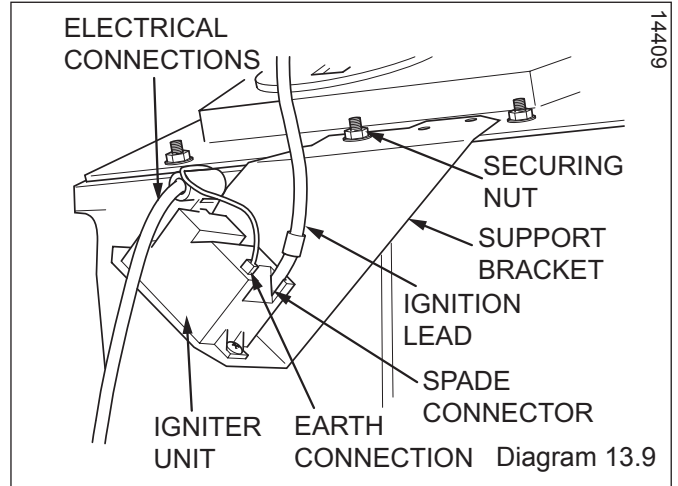

Diagram 13.9

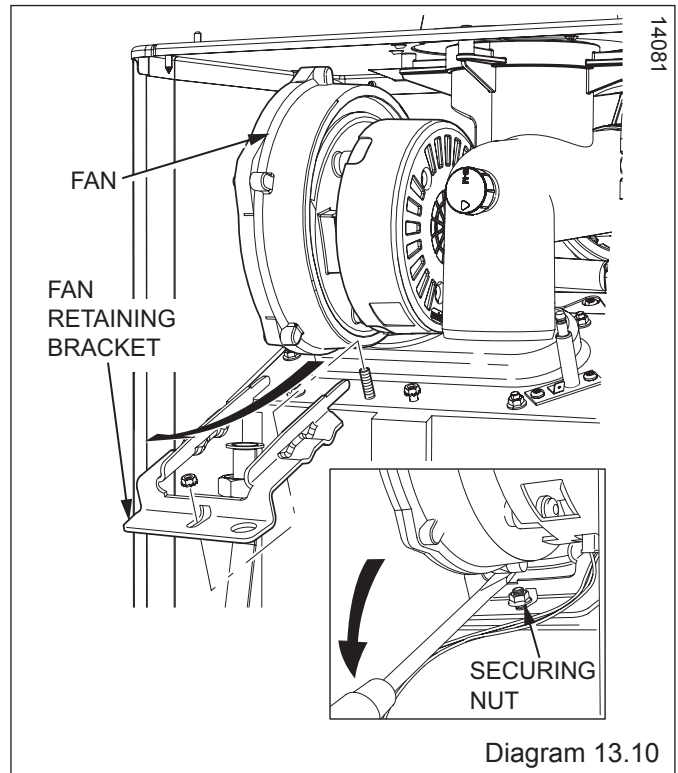

Diagram 13.10

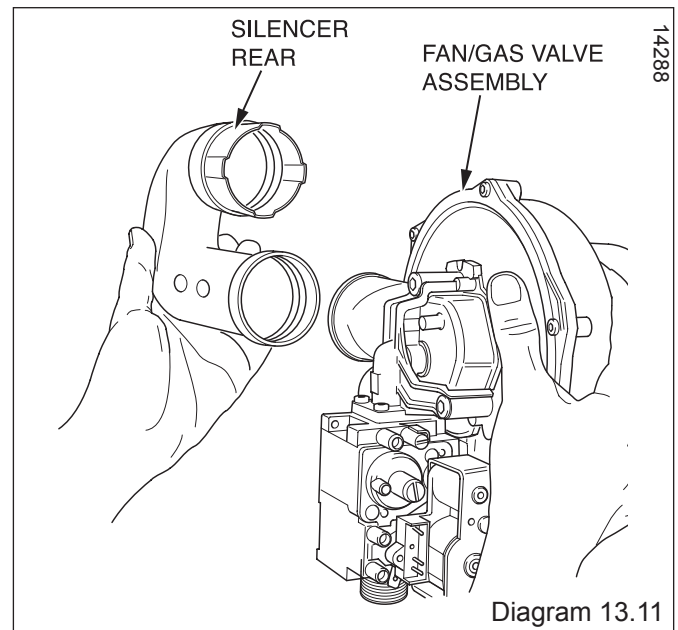

Diagram 13.11

13 Servicing

13.6. Heat Exchanger

NOTE: If the functional checks did not indicate poor combustion then it is not necessary to service this component.

Remove loose debris from inside the heat exchanger using a soft brush and vacuum cleaner.

Carefully flush by spraying water into the heat exchanger, any remaining debris should pass through the condensate trap (Ensure the water is kept away from electrical components).

13.7 Condense Trap and Siphonic Drain

The condensate trap and siphonic drain does not normally need servicing unless material deposits exceed beyond the service fill level, see diagram 13.13.

To clean the condensate trap remove the sump and rinse with water.

13.8 Casing panel seal check

NOTE: If the functional checks did not indicate poor combustion then it is not necessary to service this component.

Check the condition of the seal and replace if worn or damaged.

To replace remove the old seal and thoroughly clean the casing surfaces. Fit the new seals, these are supplied to the correct lengths and are in four pieces, for use on the sides, top and bottom.

13.9 Service Completion

Re-check the combustion as described at the beginning of this section.

On completion of the service the "Benchmark" Service Record should be completed.

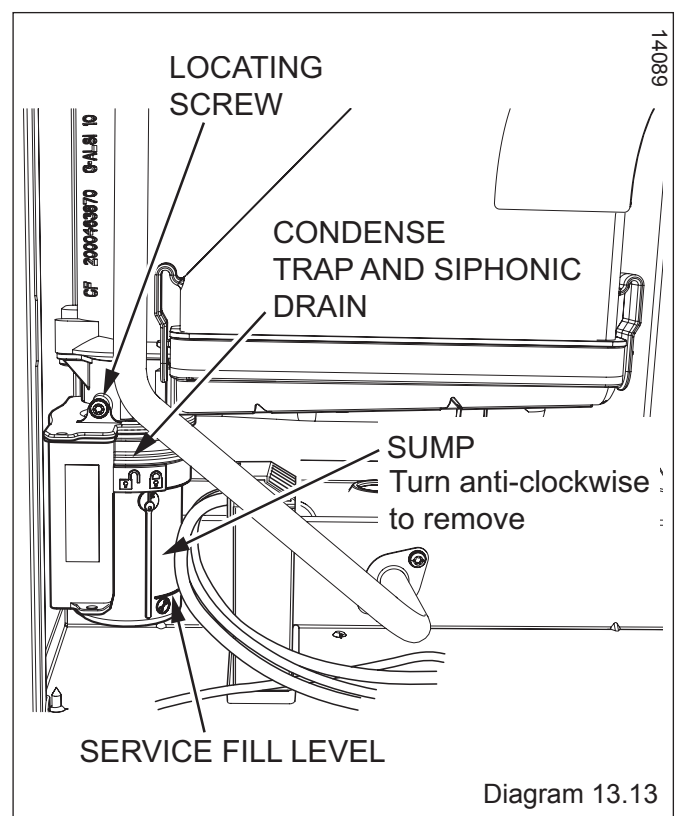
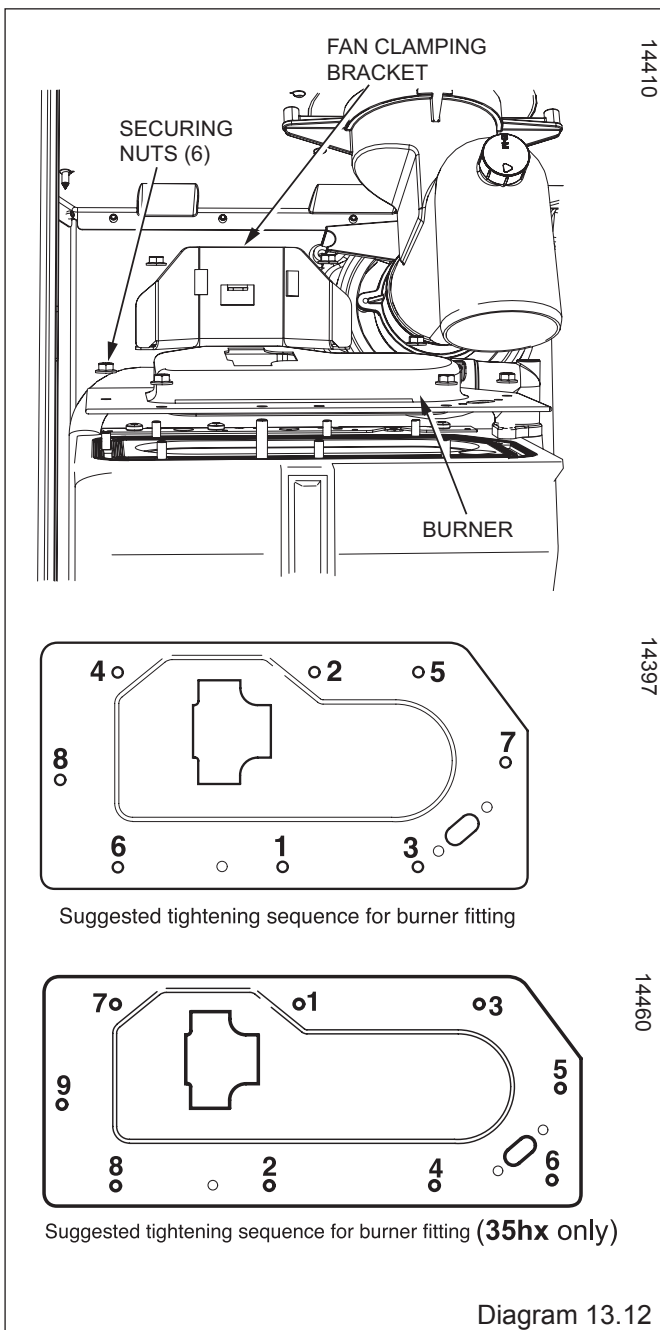

14 Fault Finding

14.1 Preliminary fault finding

The following checks should be performed before proceeding onto specific diagnostics:

- Check the external electrical supply to the boiler is on and a supply of 230V is present at the 'L' and 'N' terminals at the installer interface.

For access remove and open the electrical cartridge, see diagrams 11.4. and 11.1.

Test at the 'L' and 'N' terminals on the installer interface, refer to diagrams 11.1 and 14.4.

- Check the electrical installation and appliance, carry out tests for earth continuity, polarity, short circuit and resistance to earth, using a suitable multimeter.

An aid to test

Remove the front casing panel, see diagram 14.1 and hinge down the control box.

Unclip the rear cover to gain access to the main PCB.

Carry out the tests at connector plug X17, see diagram 14.2. Check chassis earth at a bare metal point on the boiler.

- Check that there is a gas supply to the boiler and the gas service isolation valve is turned on, see diagram 8.1.
- Check pressure at the gas service isolation valve, refer to section 12.4.
- Check that the heating system pressure indicates at least 1mb, if not, fill and vent the system as described in section 12.2.
- Check that all external controls are on.
- Check the functional flow diagram, 14.5.

14.2 Fault Codes

Fault codes take priority over all other display functions in the event of a fault occurring, refer to diagram 14.6.

If multiple faults occur the codes will be displayed for approx. 2 seconds, alternatively.

14.3 Fault Memory

The Fault memory stores details of the ten most recent faults.

To access this menu, refer to diagram 14.3:

- a) Press and hold 'MODE' and '-' buttons for 5 seconds.
- b) The display will stop flashing and alternate between the fault memory number and the fault code.
- c) Press '+' button to scroll through the fault memory (Position 1 is most recent), see fault codes.

To exit this menu, press the 'MODE' button.

14.4 Diagnostic Menu

The Diagnostic Menu provides the ability to view and change certain parameters. See diagram 14.8 for available parameters.

14.5 Status Codes

The status codes provide information about the current operating condition of the boiler and can be accessed through the diagnostic display, refer to diagram 14.7.

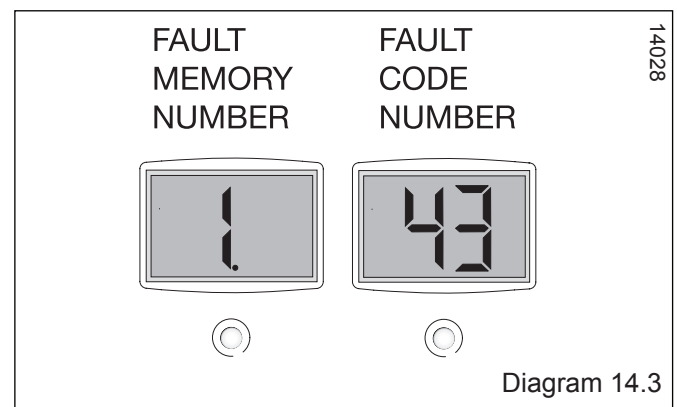
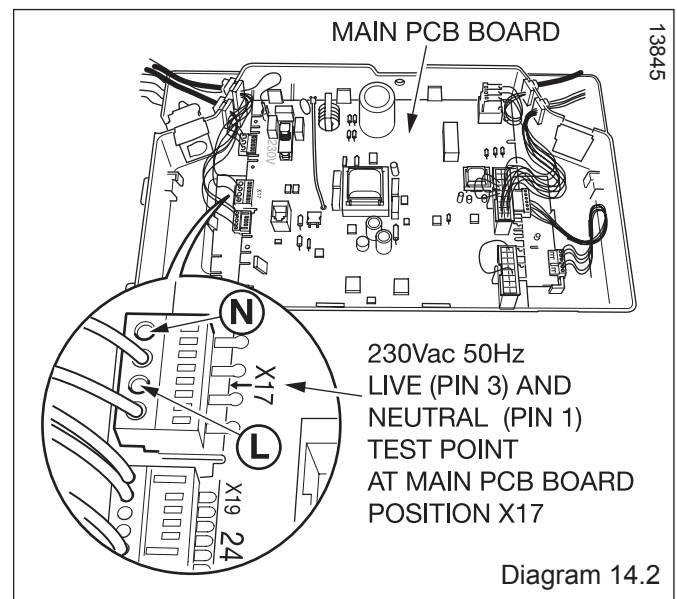
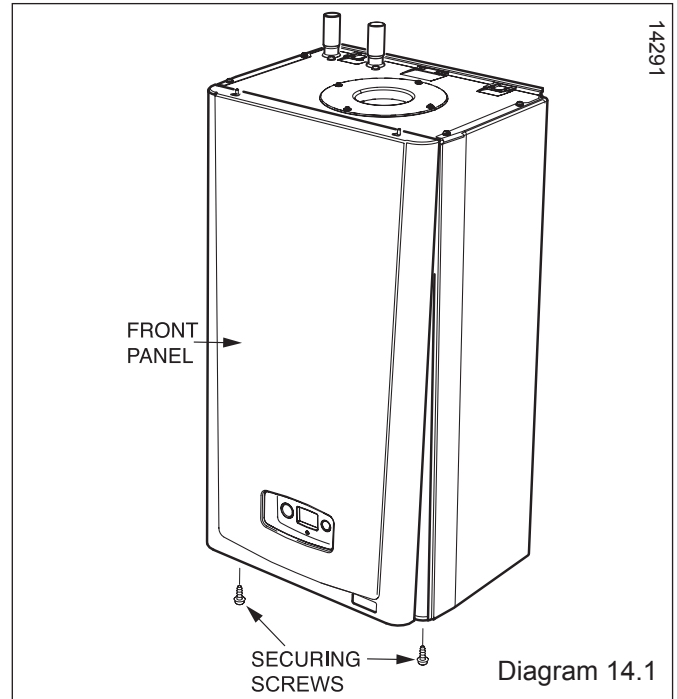

14 Fault Finding

13917

KEY	
br	BROWN
b	BLUE
g/y	GREEN/YELLOW
gy	GREY
g	GREEN
bk	BLACK
y	YELLOW
r	RED
w	WHITE
or	ORANGE
p	PURPLE
pk	PINK

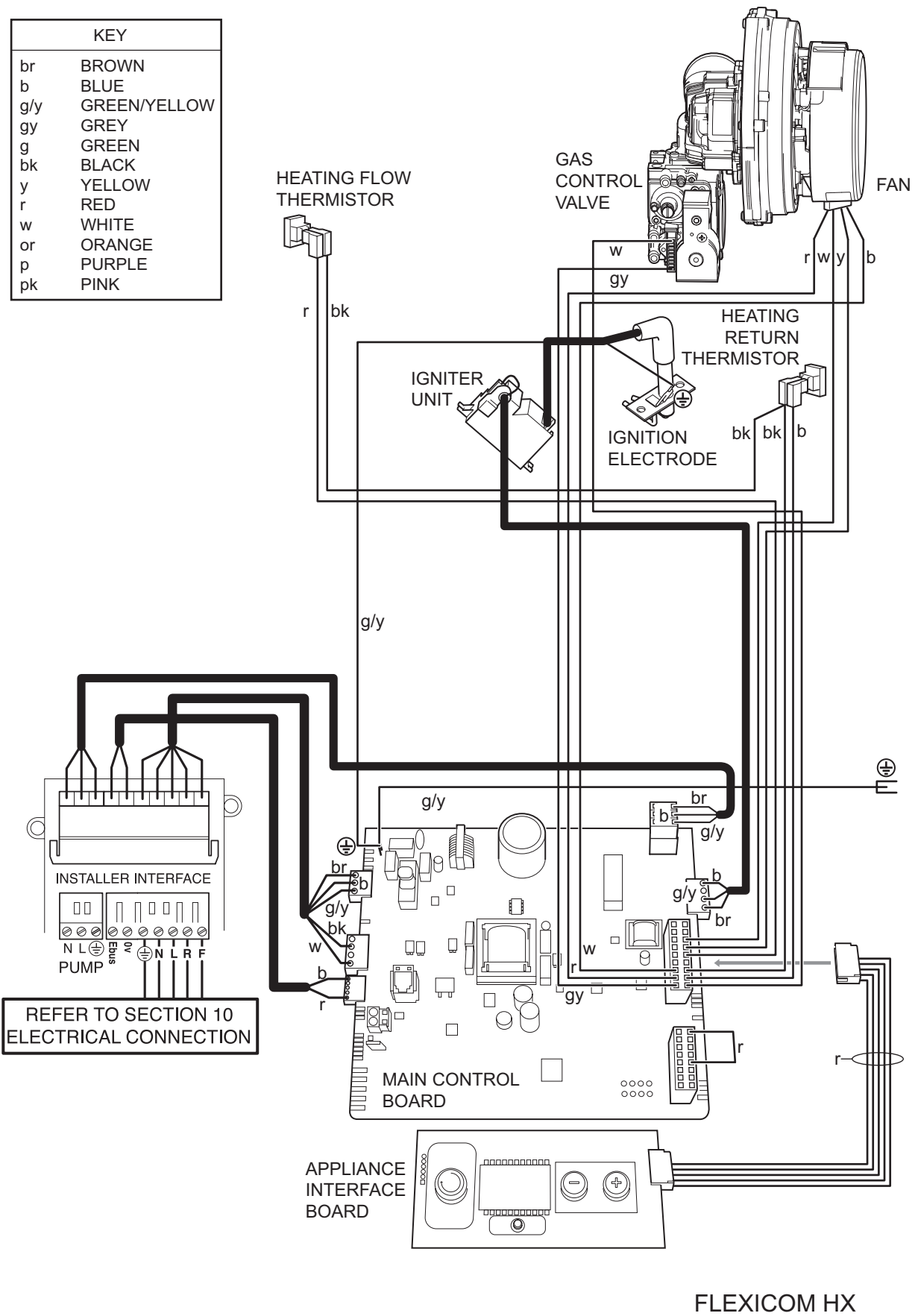

FLEXICOM HX

Diagram 14.4

14 Fault Finding

13012

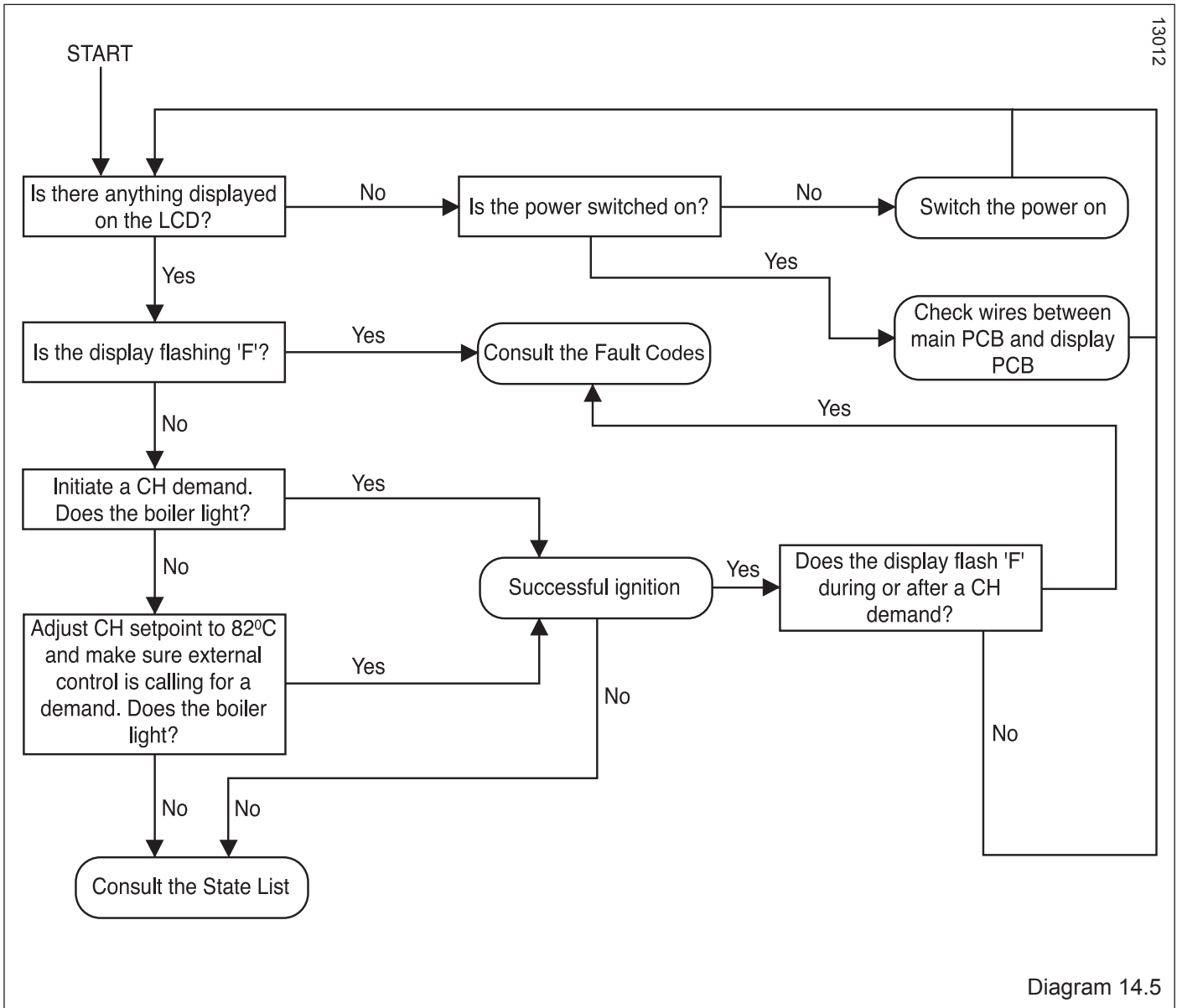

Diagram 14.5

14 Fault Finding

In all circumstances press the reset button to clear the fault. If the fault persists, consult the table below.

FAULT CODES		
CODE	DESCRIPTION	POSSIBLE CAUSE
F1	Boiler has attempted to light 5 times and failed on all occasions	Gas tap is closed. Gas valve connector is loose, unconnected, faulty, or wires are trapped. Ignitor connectors are loose, unconnected, faulty, trapped. Faulty Ignitor. Low gas inlet pressure. Incorrect gas valve adjustment. Electrode Ignition leads loose, unconnected, faulty, trapped. Electrode broken, defective, or position incorrect. Air inlet blocked, flue inlet blocked, flue duct leaking. Earthing connection loose, disconnected. Condensate blocked.
F3	Fan fault	Fan speed incorrect. Fan connector loose, unconnected, faulty or wires trapped. Faulty fan.
F4	Flame goes out whilst lit during a demand	Gas tap is closed. Gas valve connector is loose, unconnected, faulty, or wires are trapped. Ignitor connectors are loose, unconnected, faulty, trapped. Faulty Ignitor. Low gas inlet pressure. Incorrect gas valve adjustment. Electrode Ignition leads loose, unconnected, faulty, trapped. Electrode broken, defective, or position incorrect. Air inlet blocked, flue inlet blocked, flue duct leaking. Earthing connection loose, disconnected. Condensate blocked.
F5	Overheat	Boiler has overheated – allow to cool then press reset button
F6	CH Flow Thermistor connection fault	Thermistor wires unconnected, faulty, trapped.
F10	CH Return Thermistor connection fault	Thermistor wires unconnected, faulty, trapped.
F11	Flow and/or return NTC faulty	Thermistor wires unconnected, faulty, trapped.
F13	PCB Memory or sensing fault	Loose connections on Main PCB or display PCB. Central Heating Flow or Return Thermistor wires unconnected, faulty, trapped. Electrode Ignition leads loose, unconnected, faulty, trapped. Earthing connection loose, disconnected.
F14	Gas Valve control defective	Gas valve connector loose, wires unconnected, faulty or trapped. Faulty main board. Faulty gas valve.
F15	eBus Voltage failure	Short circuit on eBus, overload on eBus.
F22	Low Water pressure or Ignition temperature rise too slow	Not enough water in the system. CH flow or return thermistor wire loose, faulty, trapped. CH flow or return thermistor not connected to pipe correctly. Air in the system. Faulty pump or pump speed too fast.
F25	CHFlow temperature rise too high during operation. CHReturn temperature rise or temperature difference too high during operation. CH Temperature difference between Flow and Return too high during operation.	Check thermistors are connected to pipes correctly. Air in the system. System is too restrictive.
F43	Generic error	Check all electrical connections - internal & external
F70	Software incompatible	Telephone Group Service
F77	Condensate pump error (Option)	Trapped, faulty wiring, blockage in condensate pump.
NO DISPLAY or 'Er' displayed - Check connection from display PCB to main PCB connector X51		

Diagram 14.6

14 Fault Finding

State list - To access the state lists the '-' button must be pressed for longer than 5 seconds until it begins to flash 'S' and then a number to indicate the state. The state numbers are given below.

STATE LISTS

13131

	Central heating mode	Possible Causes
S.00	no heating required	
S.01	fan pre-run	
S.02	pump pre-run	
S.03	ignition	
S.04	burner on	
S.05	pump / fan overrun	
S.06	fan overrun	
S.07	pump overrun	
S.08	Anti cycling period	

Diagram 14.7

14 Fault Finding

To enter the diagnostics menu follow the procedure below:-

Press and hold the 'MODE' and '+' buttons for approx 5 seconds until the screen changes. Use the '+' or '-' button to select the number 96, this is the password. Hold the 'MODE' for approx 5 seconds when 96 is selected, when the screen changes release the button. The screen will flash between 'L1' and a number. 'L1' indicates you have level 1 access, the number indicates the diagnostic number below. Use the '+' and '-' to cycle through the selections below. To select a diagnostic number press the 'MODE' button when the correct number is selected. The display will show the parameter value of the diagnostic number selected. To return to the diagnostic number selector simply press the 'MODE' button. To change the parameter use the + or - buttons. Once the value has been changed it must be saved by holding the 'MODE' button for approximately 5 seconds. This will return to the diagnostic number selector.

DIAGNOSTIC CODES - LEVEL 1

Installer Access

Display	Description	Range
■ d.0	Heating part load	Adjustable heating part load in kW (factory setting: max. output)
■ d.1	Water pump over run time for heating mode	2 - 60 min (factory setting: 5 min)
■ d.2	Max. burner anti cycling period at 20°C Flow temperature	3 - 60 min (factory setting: 20 min)
d.4	N/A	N/A
d.5	Flow temperature setpoint	In °C, min. 28 and max. 82
d.8	External controls heat demand	0= no heat request (open) 1 = heat request (closed)
d.9	Flow target temperature from external intelligent control	In °C
d.10	Status central heating pump	1 = on, 0 = off
d.11	Status additional heating pump (option)	1 to 100 = on, 0 = off
d.13	Hot water circulation pump (via accessory module)	1 to 100 = on, 0 = off
d.23	Summer/Winter function	1 = Winter, 0 = Summer
d.25	Hot water activation via eBUS Control	1 = yes, 0 = no
■ d.27	Option Relay 1	Reserved for future use
■ d.28	Option Relay 2	
d.33	Fan speed target value	in rpm/10
d.34	Fan speed actual value	in rpm/10
d.40	Flow temperature	Actual value in °C
d.41	Return temperature	Actual value in °C
d.44	Ionisation current	Actual value (10nA) > 8 no flame < 4 good flame
d.60	Number of safety temperature limiter cut offs	Quantity
d.61	Number of lock outs	Number of unsuccessful ignitions in the last attempt
d.64	Average ignition time	In seconds
d.65	Maximum ignition time	In seconds
d.67	Remaining burner anti cycling time (block time)	Minutes
d.68	Unsuccessful ignitions in the first attempt	Quantity
d.69	Unsuccessful ignitions in the second attempt	Quantity
d.76	Appliance variant (device specific number)	00 to 99
d.80	Heating operating hours	in h
d.82	Cycles in heating mode	Quantity (in hundreds)
d.90	Digital regulator status	1 = identified, 0 = unidentified (eBUS Address <= 10)
d.91	Internal Programmer type (for use with Options board kit)	0:24 hour (default) 1:7 day
■ d.97	Activation of the second diagnostic level	Password needed
d.99	State List	(see diagram 14.7)

14725

■ Indicates read and write function - all other diagnostics are read only

Diagram 14.8

15 Replacement of Parts

15.1 General

Replacement of parts must be carried out by a **competent person** approved at the time by the Health and Safety Executive.

Replacement parts that have associated components that need replacing on removal, ie. 'O' ring seals, gasket, etc; will be supplied and should be fitted.

Before replacing any parts the boiler should be isolated from the mains electric supply and the gas should be turned off at the gas service isolation valve on the boiler, see diagram 15.1.

Ensure that components with electrical connections are disconnected before removal.

Unless stated otherwise parts are replaced in the reverse order to removal.

After replacing any parts always test for gas tightness and if necessary carry out functional test of the controls.

For replacement of parts the front casing of the boiler will need to be removed. To remove undo the two screws on the underside of the front casing and lift off.

The side panels can be removed to aid replacement of parts.

To hinge a side panel undo and remove the four screws securing each side panel to the boiler, two below and two at the top.

15.2 Igniter Unit

For access, refer to section 15.1.

Remove ignition lead and electrical connections then remove igniter unit by removing two securing screws, see diagram 13.9.

15.3 Ignition Lead

For access, refer to section 15.1.

Pull the spark plug style connector off the spark electrode and the spade connector connected to the igniter unit, see diagrams 13.6 and 13.9.

15.4 Silencer Assembly (front)

For access, refer to section 15.1.

Pull forwards to remove.

The silencer is a push fit so no tools or fixings are required for its removal or fitting, see diagram 13.8.

15.5 Gas Valve

Remove the three securing screws, holding the gas valve to the fan, see diagram 13.7.

Remove the gas valve.

After re-fitting check the combustion CO₂ and adjust if necessary, refer to section 13.1, Combustion Check.

After assembly test for gas tightness and purge in accordance with the current issue of BS6891 or in IE, the current edition of I.S.813 "Domestic Gas Installations".

15.6 Flue Hood

For access, refer to section 15.1.

Pull the flue hood securing clips away from the flue hood sump and push flue hood up slightly towards flue hood top, see diagram 13.5.

To remove swivel flue hood 90° and pull down and out towards front of boiler.

15.7 Fan/Gas valve assembly

For access, refer to section 15.1.

Undo the tubing nut to remove the gas valve from the gas pipe and any electrical connections, see diagram 13.7.

Remove the securing nut holding the fan retaining bracket, press down on burner to ease removal of securing nut. Slide out the fan retaining bracket.

Lift front of bracket away from stud and pull forward to release the fan, see diagram 13.10.

Lift fan/gas valve assembly up and forward away from locating studs.

Remove fan gasket and replace.

To replace the fan and retaining bracket correctly, insert into slots on fan clamping bracket and locate onto lugs on the burner, see diagram 13.10.

15.8 Silencer assembly (rear)

For access, refer to section 15.1.

Remove the fan/gas valve assembly, see section 15.7.

Pull Silencer rear away from fan/gas valve assembly.

The rear silencer is a push fit so no tools or fixings are required for its removal or fitting, see diagram 13.11.

15.9 Spark Electrode

For access, refer to section 15.1.

Remove the spark plug lead and earth lead.

Remove the two securing nuts.

Withdraw the spark electrode by slowly pulling up and leaning it forward towards the centre of the heat exchanger to ensure that the electrode does not foul on the hole in the burner casing.

Check spark gap, see diagram 13.6.

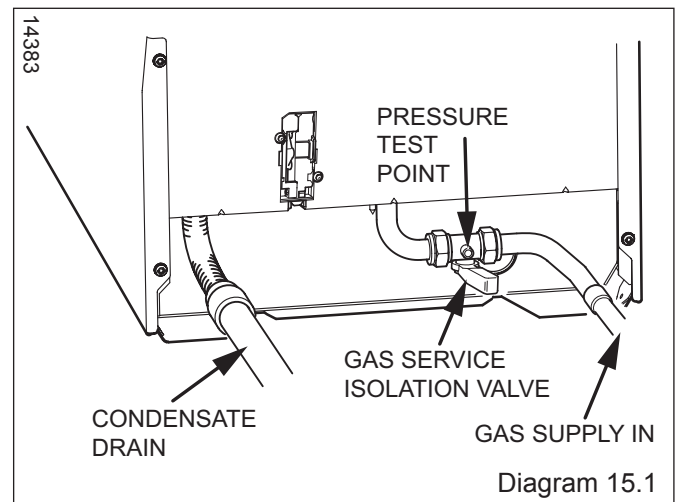

15 Replacement of Parts

15.10 Burner

For access, refer to section 15.1.

Remove igniter unit, flue hood, fan and gas valve assembly and spark electrode lead, refer to relevant sections.

Remove the flanged nuts and studs that secure the burner, note that two studs at the rear also hold the fan clamping bracket, see diagram 13.10.

NOTE: The burner gasket should be inspected but will not need replacing unless there are signs of wear or damage.

IMPORTANT: Do not allow fixings, nuts, screws, etc. to fall into the open flue hood sump, use a temporary cover whilst removing any parts.

15.11 Condensate Trap

For access, refer to section 15.1.

Remove securing screw, see diagram 13.13.

Disconnect the flexible condensate drain pipe from the external plastic drain pipe beneath the boiler.

Carefully pull the condensate trap down and forward so as not to spill its contents. The trap should be removed complete with the sealing grommet and flexible condensate drain pipe.

15.12 Heating Flow Thermistor

For access refer to section 15.1

Remove the silencer front, fan/gas valve assembly and flue hood for access. See relevant sections.

Refer to diagram 15.2.

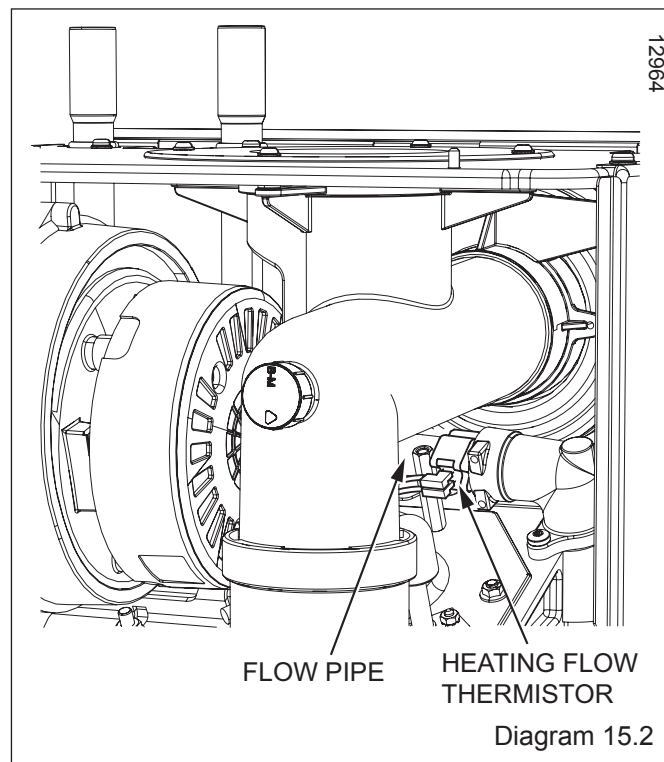

15 Replacement of Parts

15.13 Heating Return Thermistor

For access, refer to section 15.1.

Refer to diagram 15.3.

Remove the electrical connections from the thermistor.

Remove the retaining clip from the return pipe.

Remove the thermistor from the retaining clip.

Note that the polarity of the wiring to thermistor is unimportant.

15.14 Heat Exchanger

For access, refer to section 15.1.

Drain down the boiler heating circuit

Remove the silencer front

Pull forwards to remove.

The silencer is a push fit so no tools or fixings are required for its removal or fitting, see diagram 13.8.

Remove the flue hood front

Ease the securing clips away from the sump to release the retaining catch then push the flue hood up to disengage from the sump, see diagram 13.5.

To remove, swivel flue hood 90° and pull down and out, see diagram 13.5.

Remove the igniter unit with support bracket

Disconnect the electrical connections and ignition lead.

Release the igniter unit support bracket.

Remove the igniter unit assembly, see diagram 13.9.

Remove the gas valve/fan

Disconnect the tubing nut at the gas valve, see diagram 13.7.

Remove the fan retaining bracket, see diagram 13.10.

To ease removal of the securing nut from the fan retaining bracket, a flat bladed screwdriver can be used in the position shown and gently levered down as indicated.

Remove the spark electrode plug and earth connection.

Remove the fan and gas valve electrical connections.

Remove the fan and gas valve assembly.

Remove the condensate trap

Remove the drain outlet pipe from the base of the trap, see diagram 15.1. Remove the condensate drain securing screw and carefully pull the trap forward, see diagram 13.13.

Drain the heat exchanger

Drain the heat exchanger using the drain point on the right hand side of the heat exchanger, see diagram 15.4.

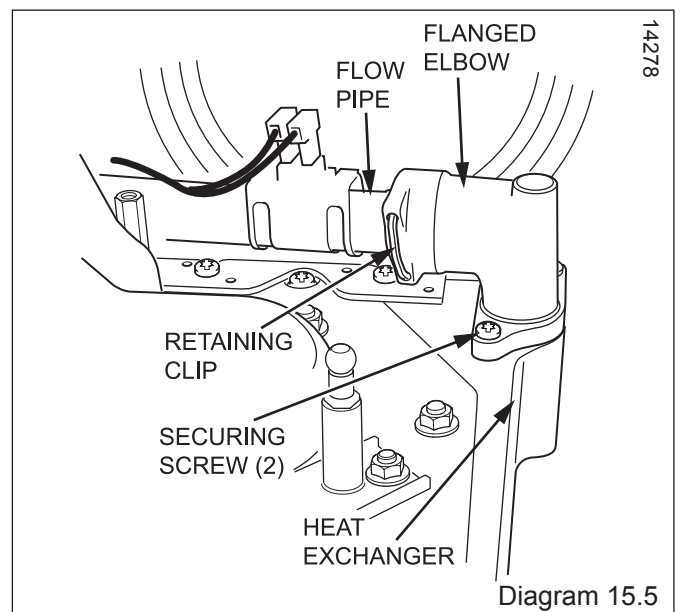
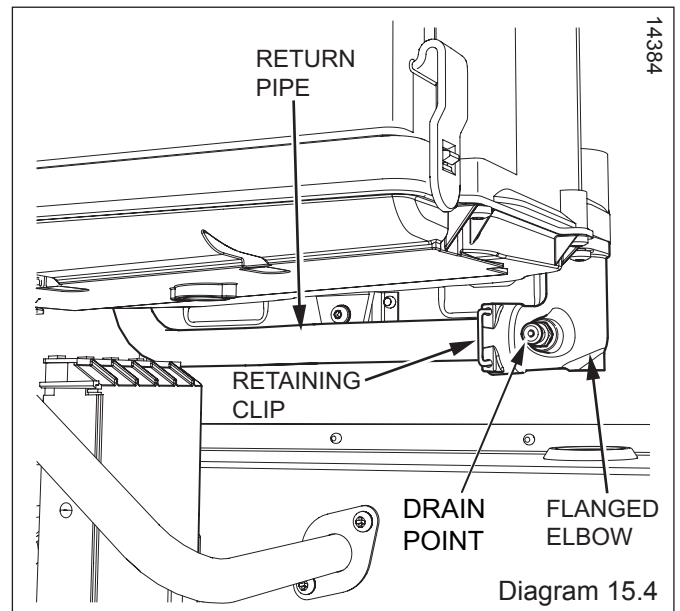
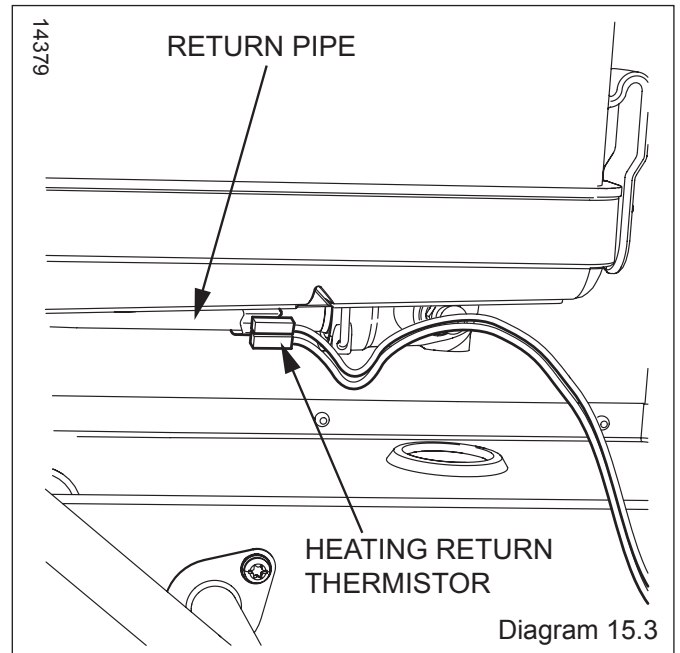

15 Replacement of Parts

Remove the heat exchanger

Undo the screws securing the flanged elbow on the top right hand side of the heat exchanger and remove the retaining clip from the flanged elbow, see diagram 15.5.

Remove retaining clip from the flanged elbow on the bottom of the heat exchanger, see diagram 15.4.

Remove screws securing the heat exchanger, one on top and one underneath the heat exchanger, see diagram 15.6.

Lift up heat exchanger slightly to disengage it from its hanging bracket.

Remove the heat exchanger by pulling forward, then pulling to the right to disengage the return pipe and tilting backwards to ease removal complete with sump. Discard the heat exchanger and flanged elbows.

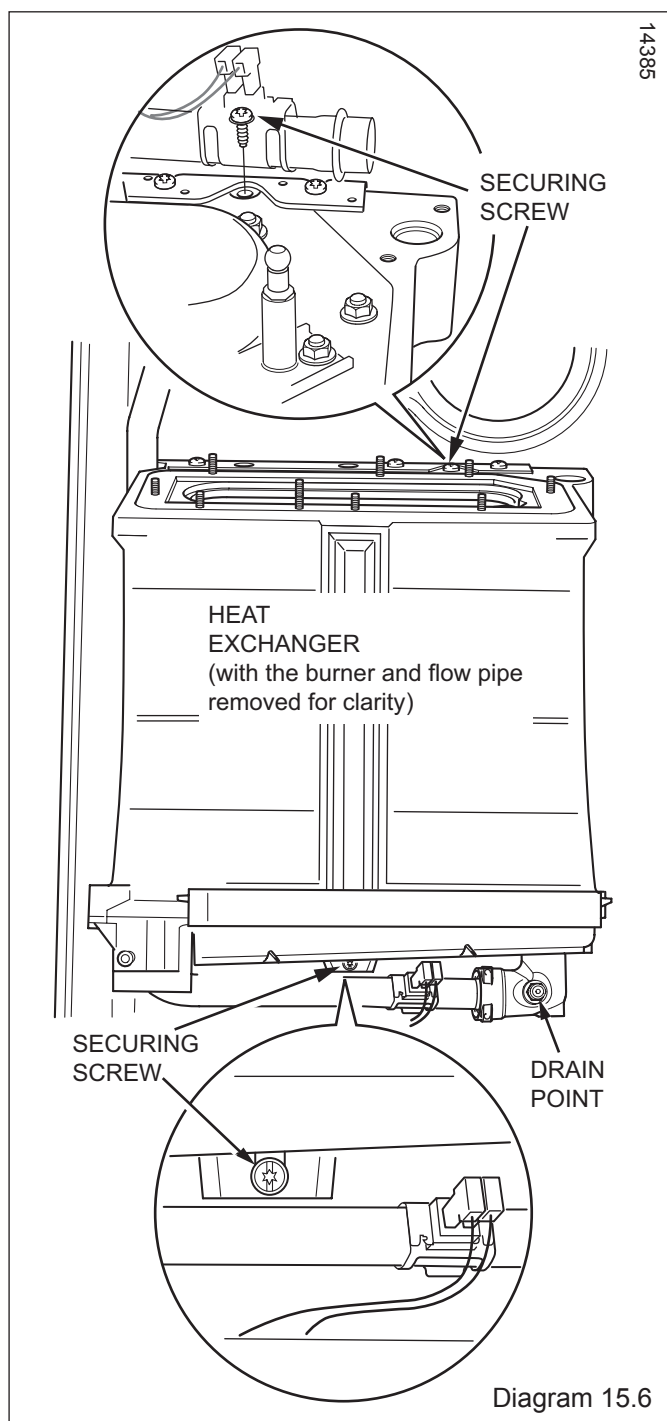

Remove the burner

Remove the six flanged nuts and two studs that secure the burner, note that the two studs also hold the fan clamping bracket, see diagram 15.7.

Taking great care not to damage the surface of the burner.

NOTE: Replace the burner gasket and follow the tightening sequence when re-fitting the burner, see diagram 15.7.

NOTE: Fit all replacement gaskets and seals when re-fitting parts.

Refer to Section 12.

Fill the boiler heating system.

Re-pressurise (sealed system only)

Check for any leaks.

Vent all air from the system.

Test for gas tightness, earth continuity, polarity, short circuit and resistance to earth.

Light the boiler and carry out functional checks.

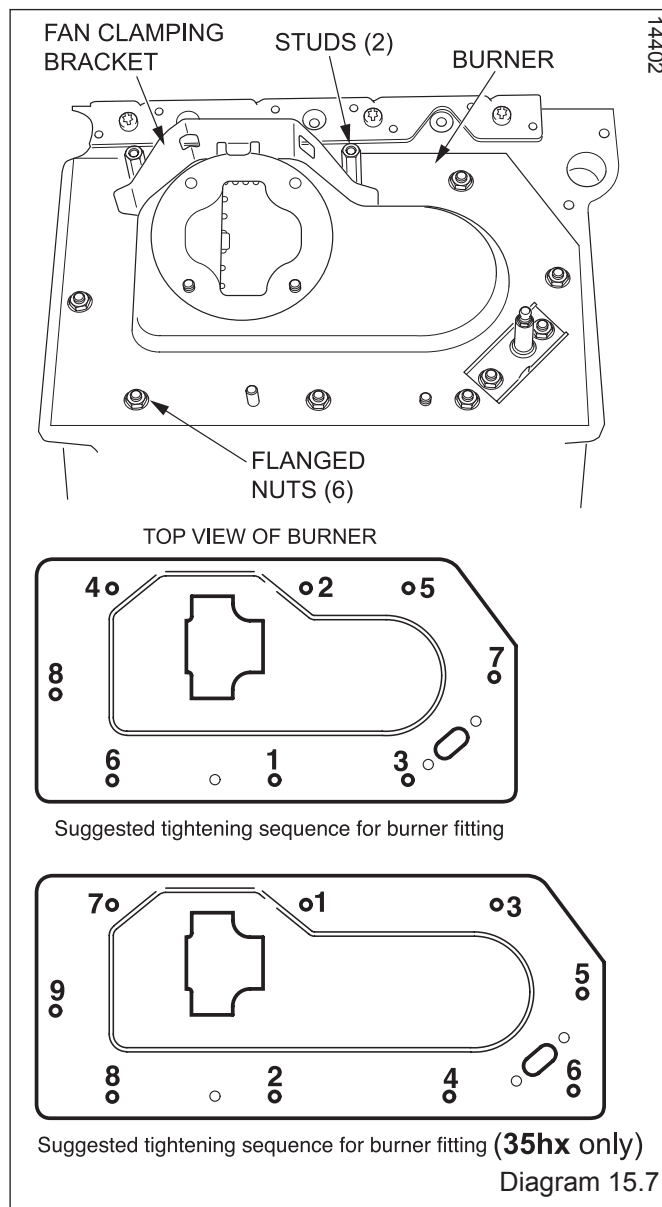

15 Replacement of Parts

15.15 Casing Seal

Refer to Section 13.8.

15.16 Access to User interface and Main PCB

For access, refer to section 15.1.

Hinge down the control box and unclip the rear cover to gain access.

Remove electrical connections from main PCB noting their positions for replacement.

Unclip main PCB and remove, see diagram 15.8.

Unclip user interface and remove.

For replacement, see diagram 15.9 and ensure that the user interface connection cable is refitted.

NOTE: When re-fitting any of the control boards make sure you support the control box to avoid straining hinges as you push down and clip back into place.

15.17 Control Box

For access, refer to section 15.1.

Hinge down the control box and unclip the rear cover to gain access.

Remove relevant electrical connections from main PCB and grommets from the control box.

IMPORTANT: Support the control box whilst undoing the hinges.

Remove the hinge securing screws accessed from beneath the boiler and remove the control box, see diagram 15.10.

15.18 Fuse - Main PCB - Control Box

For access, refer to section 15.16.

The fuse is located at the top left hand corner of the main PCB, see diagram 15.8.

15.19 Installer Interface Electrical Cartridge

Remove the Installer Interface securing screw accessed from beneath the boiler.

Carefully pull down the electrical cartridge, disconnect the cables.

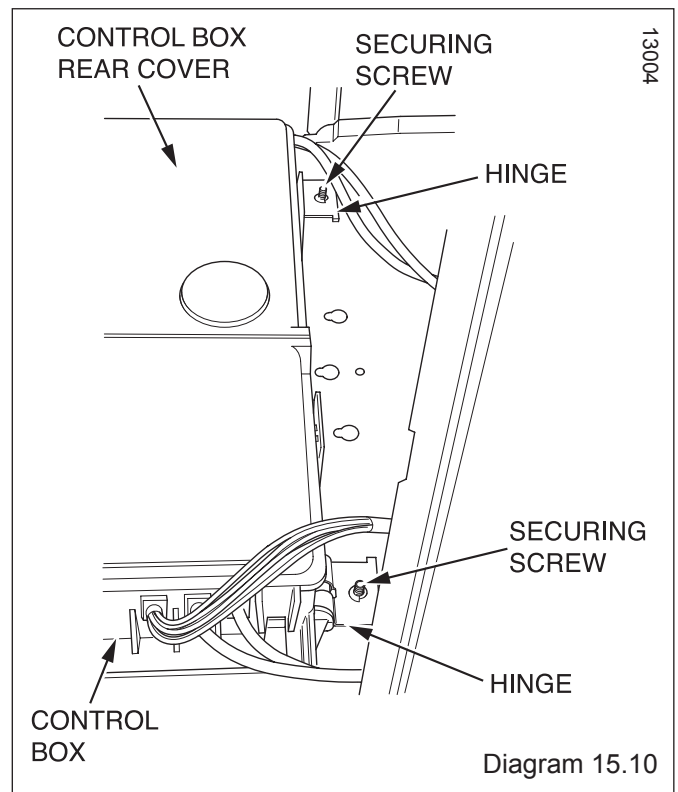
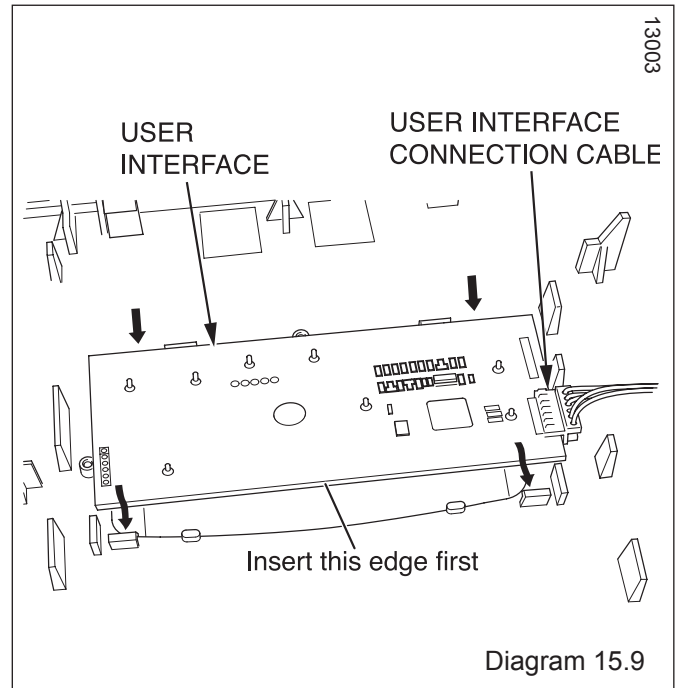
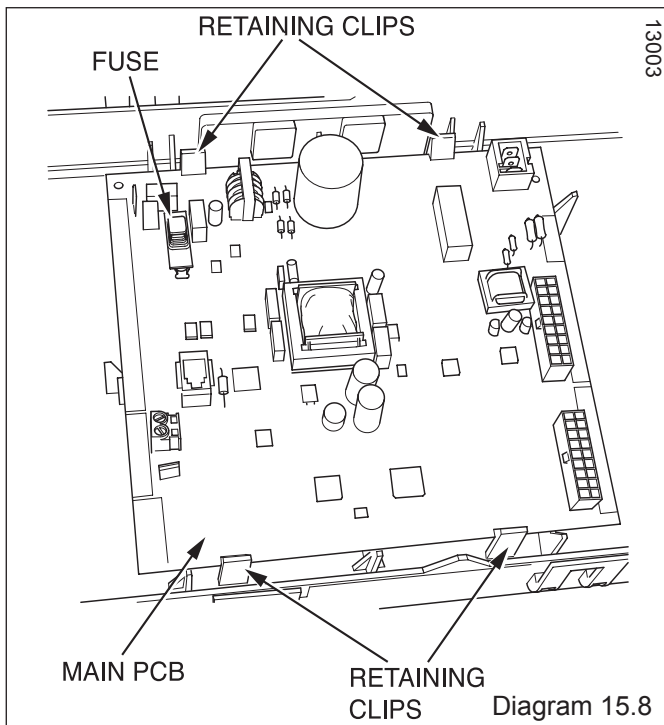

16 Spare Parts

Key No.	Part No.	Description	GC No
1	0020020734	Fan	H42723
2	0020020763	Igniter unit	H42773
3	0020020781	Heating flow & return thermistor (2)	H42792
4	0020020735	Gas valve 12hx - 30hx	H42724
4	0020059600	Gas valve 35hx	H69002
5	0020020731	Spark Electrode	H42720
6	0020020728	Burner 12hx - 30hx	H42718
6	0020059601	Burner 35hx	H68999
7	0020023826	User interface	H42784
8	0020023825	Main P.C.B.	H42783

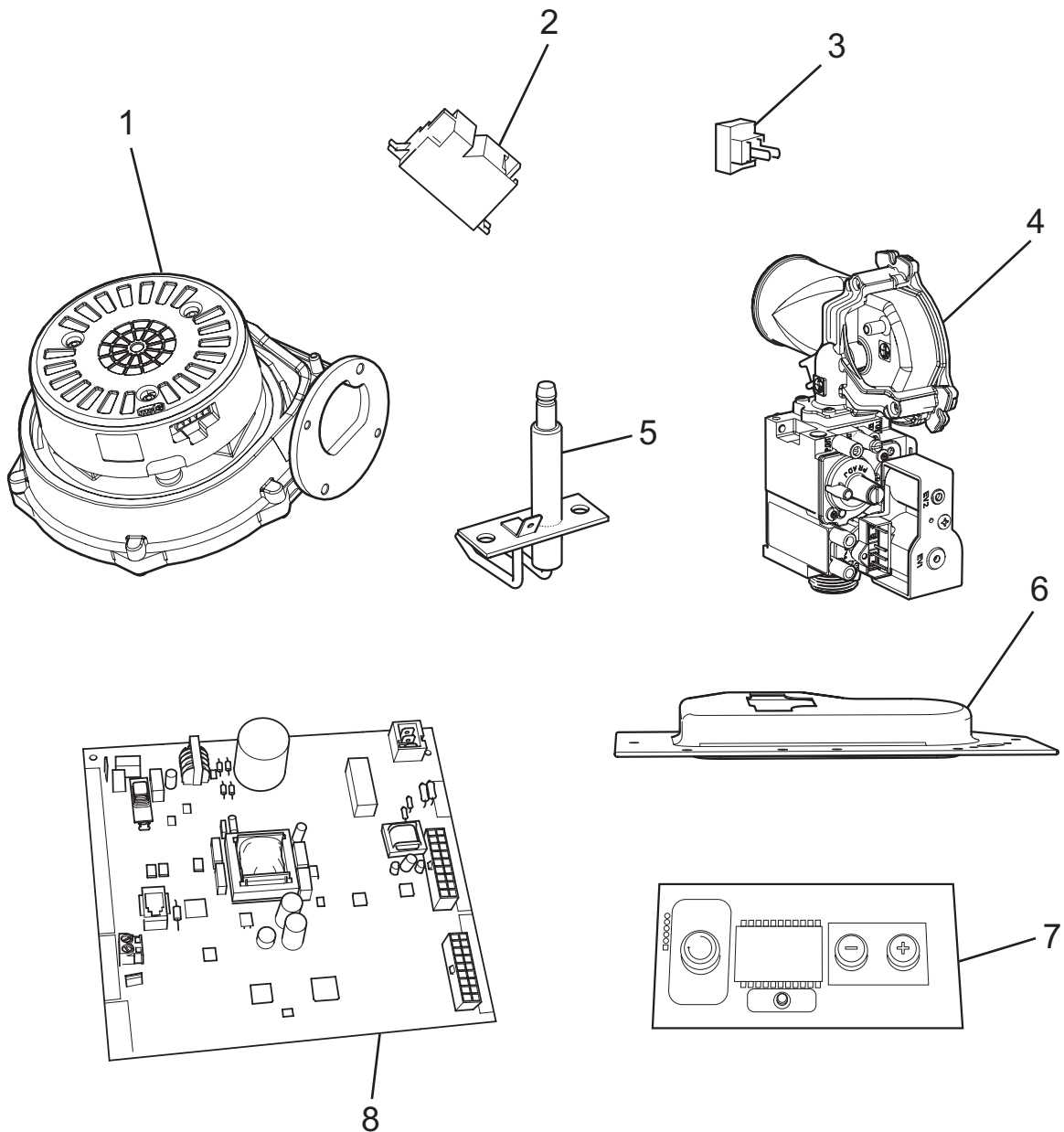

13013

Diagram 16.1

17 Manual Handling

IMPORTANT. With regards to the Manual Handling Operations, 1992 Regulations, the following lift operation exceeds the recommended weight for a one man lift.

General recommendations when handling

Clear the route before attempting the lift.

Ensure safe lifting techniques are used – keep back straight – bend using legs. Keep load as close to body as possible. Do not twist – reposition feet instead. If 2 persons performing lift, ensure co-ordinated movements during lift. Avoid upper body/top heavy bending - do not lean forward/sideways. Recommend wear suitable cut resistant gloves with good grip to protect against sharp edges and ensure good grip. Always use assistance if required.

Removal of carton from delivery van

Recommend 2 person lift or 1 person with use of sack truck. If 1 person is performing lift, straddle the load, tilt and place carton into position on truck. Recommend secure appliance onto truck with suitable straps. Ensure safe lifting techniques are used – keep back straight – bend using legs. Keep load as close to body as possible. If 2 persons performing lift, ensure co-ordinated movements during lift. Always use assistance if required.

Carriage of carton from point of delivery to point of installation – ground floor.

Recommend 2 person lift or 1 person with use of sack truck. If 1 person is performing lift, straddle the load, tilt and place carton into position on truck. Recommend secure appliance onto truck with suitable straps. Ensure safe lifting techniques are used – keep back straight – bend using legs. Keep load as close to body as possible. If 2 persons performing lift, ensure co-ordinated movements during lift. Clear the route before attempting the lift. If removing boiler from truck straddle the load and tilt forwards to facilitate secure grip. Ensure safe lifting techniques are used – keep back straight – bend using legs. Do not twist – reposition feet instead. Take care to avoid trip hazards, slippery or wet surfaces and when climbing steps and stairs. Always use assistance if required.

Carriage of carton from point of delivery to point of installation – first or higher floor, cellar.

Recommend 2-person lift or 1 person with use of sack truck. If 1 person is performing lift, straddle the load, tilt and place carton into position on truck. Recommend secure appliance onto truck with suitable straps. Ensure safe lifting techniques are used – keep back straight – bend using legs. Keep load as close to body as possible. If 2 persons performing lift, ensure co-ordinated movements during lift. Avoid upper body/top heavy bending - do not lean forward/sideways. Clear the route before attempting the lift. If removing boiler from truck straddle the load and tilt forwards to facilitate secure grip. Ensure safe lifting techniques are used – keep back straight – bend using legs. Do not twist – reposition feet instead. Take care to avoid trip hazards, slippery or wet surfaces and when climbing steps and stairs. Always use assistance if required.

Carriage of carton from point of delivery to point of installation – roofspace.

Recommend 2-person lift. Ensure co-ordinated movements during lift. Avoid upper body/top heavy bending - do not lean forward/sideways. Clear the route before attempting the lift. Take care to avoid trip hazards, slippery or wet surfaces and when climbing steps and stairs. When transferring appliance into roofspace, recommend 1 person to be in roofspace to receive the appliance and other person to be below to pass up and support appliance. Ensure safe lifting techniques are used – keep back straight – bend using legs. Keep load as close to body as possible. Always use assistance if required. It is assumed safe access, flooring and adequate lighting are provided in the roof space. It is recommended a risk assessment of the roof space area be carried out before moving the appliance into the area to take into account access, stability of flooring, lighting and other factors, and appropriate measures taken.

Unpacking of appliance from carton.

Recommend 2 persons unpack appliance from carton. Always keep working area clear. Recommend cut base end of carton and open carton flaps, then tilt boiler forwards from its side onto its base and remove carton by sliding up over the boiler. Ensure safe lifting techniques are used – keep back straight – bend using legs. Keep load as close to body as possible. Always use assistance if required. Dispose

of packaging in a responsible manner. Recommend wear suitable cut resistant gloves with good grip to protect against sharp edges and ensure good grip when handling appliance outside packaging.

Positioning of Appliance for Final Installation – no obstructions.

This appliance is deemed to be a one person lift when removed from the carton. Fit bracket securely onto wall before lifting appliance into position. Obtain firm grip on front and sides of appliance, lift upwards, ensure stable balance achieved and lift upwards to position in place on bracket. Ensure safe lifting techniques are used – keep back straight – bend using legs - when lifting load from floor level. Do not twist – reposition feet instead. Keep boiler as close as possible to body throughout lift to minimise strain on back. Ensure co-ordinated movements to ensure equal spread of weight of load. Always use assistance if required. Recommend wear suitable cut resistant gloves with good grip to protect against sharp edges and ensure good grip when handling appliance.

Positioning of Appliance for Final Installation – above worktop, foreseeable obstructions etc.

This appliance is deemed to be a one person lift when removed from the carton. Fit bracket securely onto wall before lifting appliance into position. Obtain firm grip on front and sides of appliance, lift upwards, onto worktop if practicable. Ensure stable balance achieved and lift upwards to position in place on bracket. If 2 persons positioning onto bracket obtain firm grip at front and sides/base of boiler. Ensure co-ordinated movements during 2 person lifts to ensure equal spread of weight of load. Ensure safe lifting techniques are used – keep back straight – bend using legs - when lifting load from floor level. Do not twist – reposition feet instead. Keep boiler as close as possible to body throughout lift to minimise strain on back. Avoid upper body/top heavy bending - do not lean forward/sideways. Always use assistance if required. Recommend wear suitable cut resistant gloves with good grip to protect against sharp edges and ensure good grip when handling appliance.

Positioning of Appliance for Final Installation – within compartment etc. restricting installation.

This appliance is deemed to be a one person lift when removed from the carton. Fit bracket securely onto wall before lifting appliance into position. Obtain firm grip on front and sides of appliance, lift upwards, onto worktop if practicable. Ensure stable balance achieved and lift upwards to drop into place onto bracket. If 2 persons positioning onto bracket obtain firm grip at front and sides/base of boiler. Ensure co-ordinated movements during 2 person lifts to ensure equal spread of weight of load. If 1 person positioning onto bracket recommend obtain firm grip supporting base of boiler. Ensure safe lifting techniques are used – keep back straight – bend using legs - when lifting load from floor level. Do not twist – reposition feet instead. Keep boiler as close as possible to body throughout lift to minimise strain on back. Always use assistance if required. Recommend wear suitable cut resistant gloves with good grip to protect against sharp edges and ensure good grip when handling appliance.

Positioning of Appliance for Final Installation – in roof space restricting installation.

This appliance is deemed to be a one person lift when removed from the carton. Obtain firm grip on front and sides of appliance, lift upwards, ensure stable balance achieved and lift upwards to drop into place onto bracket. If 2 persons positioning onto bracket obtain firm grip at front and sides/base of boiler. Ensure co-ordinated movements during 2 person lifts to ensure equal spread of weight of load. If 1 person positioning onto bracket recommend obtain firm grip supporting base of boiler. Ensure safe lifting techniques are used – keep back straight – bend using legs - when lifting load from floor level. Do not twist – reposition feet instead. Keep boiler as close as possible to body throughout lift to minimise strain on back. Always use assistance if required. Recommend wear suitable cut resistant gloves with good grip to protect against sharp edges and ensure good grip when handling appliance. It is recommended a risk assessment of the roof space area be carried out before moving the appliance into the area to take into account access, stability of flooring, lighting and other factors, and appropriate measures taken.

18 Declaration of Conformity



EC declaration of conformity

Name and Address of the manufacturer: Glow-worm
Nottingham Road
Belper
Derbyshire DE56 1JT

Identification of product: **Glow worm :- Flexicom Series, Condensing Wall Hung Heating only Boilers**

Appliance type: **Flexicom 12hx, 15hx, 18hx, 24hx, 30hx & 35hx**

The appliance types satisfy the essential requirements of the relevant directives and Standards:

90/396/EEC including amendments "Directive on the approximation of the law of the member states relating to appliances burning gaseous fuels"	Designed and built to CE-type examination certificate: PIN no: 87BQ86
92/42/EEC including amendments "Directive of efficiency relating to boiler burning gaseous fuels"	Designed and built according to European Standards:
73/23/EEC including amendments "Directive on the harmonization of the laws of Member States relating to electrical equipment designed for use within certain voltage limits"	EN 483 EN 677 EN 625 EN 60335-1 EN 60529 EN 50165
89/336/EEC including amendments "Directive on the approximation of the law of the member states relating to electromagnetic compatibility"	EN 55014 EN 61000-3-2 EN 61000-3-3

Any change to the appliance and/or any use not according to the instructions will lead to the invalidation of this Declaration of Conformity

Belper, October 2007
(place, date)

Program Manager
S. Keeton

Certification Manager
A. Beardsley

Glow-worm – Nottingham Road – Belper – Derbyshire – DE56 1JT

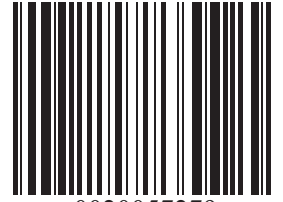

0020057279

Glow-worm, Nottingham Road, Belper, Derbyshire. DE56 1JT

Because of our constant endeavour for improvement, details may vary slightly from those shown in these instructions.

0020057279-04 01.10