



# Glow-worm

## Installation and maintenance instructions

Energy<sub>7</sub>

Energy<sub>7</sub> 25c -A (H-GB)

Energy<sub>7</sub> 30c -A (H-GB)

Energy<sub>7</sub> 35c -A (H-GB)



**GB, IE**

## Contents

<b>1</b>	<b>Safety</b> .....	<b>4</b>	9.6	Checking the factory setting .....	31
1.1	Intended use .....	4	9.7	Avoiding danger arising from insufficient water pressure .....	31
1.2	Qualification .....	4	9.8	Switching on the product .....	31
1.3	General safety information .....	4	9.9	Filling and purging the heating installation .....	31
1.4	Regulations (directives, laws, standards) .....	6	9.10	Filling the domestic hot water circuit .....	31
1.5	List of relevant standards for Great Britain and Ireland .....	6	9.11	Checking the gas setting .....	32
<b>2</b>	<b>Guarantee and Customer Service</b> .....	<b>7</b>	9.12	Thoroughly flushing the heating installation ("hot") .....	33
<b>3</b>	<b>Technical data</b> .....	<b>8</b>	9.13	Checking leak-tightness .....	33
<b>4</b>	<b>Notes on the documentation</b> .....	<b>11</b>	<b>10</b>	<b>Adapting the unit to the installation</b> .....	<b>35</b>
<b>5</b>	<b>Product description</b> .....	<b>12</b>	10.1	Setting the burner anti-cycling time .....	35
5.1	CE marking .....	12	10.2	Setting the pump output .....	35
5.2	Benchmark .....	12	10.3	Setting the bypass valve .....	35
5.3	Information on the data plate .....	12	10.4	Setting the domestic hot water temperature .....	36
5.4	Functional elements: Combi boiler .....	13	<b>11</b>	<b>Handing over to the end user</b> .....	<b>36</b>
5.5	Safety Devices .....	13	<b>12</b>	<b>Inspection and maintenance</b> .....	<b>37</b>
<b>6</b>	<b>Set-up</b> .....	<b>14</b>	12.1	Using original seals .....	37
6.1	Unpacking the product .....	14	12.2	Observing inspection and maintenance intervals .....	37
6.2	Checking the scope of delivery .....	14	12.3	Procuring spare parts .....	37
6.3	Dimensions .....	14	12.4	Checking the CO <sub>2</sub> content .....	37
6.4	Installation site .....	15	12.5	Removing the gas-air mixture unit .....	37
6.5	Minimum clearances .....	15	12.6	Cleaning the heat exchanger .....	38
6.6	Compartment Ventilation .....	15	12.7	Checking the burner .....	38
6.7	Air/flue pipe .....	15	12.8	Checking the ignition electrode .....	38
6.8	Using the mounting template .....	20	12.9	Cleaning the condensate siphon .....	38
6.9	Wall-mounting the product .....	20	12.10	Cleaning the strainer in the cold water inlet .....	39
6.10	Removing/installing the front casing .....	21	12.11	Cleaning the heating filter .....	39
6.11	Removing/installing the side section .....	21	12.12	Installing the gas-air mixture unit .....	39
<b>7</b>	<b>Installation</b> .....	<b>22</b>	12.13	Draining the product .....	39
7.1	Preparing for installation .....	22	12.14	Checking the pre-charge pressure of the expansion vessel .....	39
7.2	Flushing the heating installation for the first time ("cold") .....	22	12.15	Completing inspection and maintenance work ....	39
7.3	Checking the gas meter .....	22	12.16	Checking the product for leak-tightness .....	39
7.4	Checking the gas flow rate .....	22	<b>13</b>	<b>Troubleshooting</b> .....	<b>40</b>
7.5	Gas and water connections .....	22	13.1	Eliminating faults .....	40
7.6	Connecting the drain pipework for the expansion relief valve .....	23	13.2	Calling up the fault memory .....	40
7.7	Connecting the condensate discharge pipe .....	24	13.3	Deleting the fault memory .....	40
7.8	Flue installation .....	26	13.4	Resetting parameters to factory settings .....	40
7.9	Electrical installation .....	26	13.5	Preparing the repair work .....	40
<b>8</b>	<b>Operation</b> .....	<b>28</b>	13.6	Replacing defective components .....	40
8.1	Using diagnostics codes .....	28	13.7	Checking the product for leak-tightness .....	43
8.2	Displaying the status codes .....	28	<b>14</b>	<b>Decommissioning the product</b> .....	<b>44</b>
8.3	Using check programmes .....	28	<b>15</b>	<b>Recycling and disposal</b> .....	<b>44</b>
<b>9</b>	<b>Start-up</b> .....	<b>29</b>	<b>Appendix</b> .....	<b>45</b>	
9.1	Carrying out the initial start-up .....	29	<b>A</b>	<b>Inspection and maintenance work</b> .....	<b>45</b>
9.2	Heating water supply in the sealed heating system .....	29	<b>B</b>	<b>Check programmes – Overview</b> .....	<b>46</b>
9.3	Checking and treating the heating water/filling and supplementary water .....	29	<b>C</b>	<b>Overview of diagnostics codes</b> .....	<b>47</b>
9.4	Filling the condensate siphon .....	30	<b>D</b>	<b>Status codes – Overview</b> .....	<b>50</b>
9.5	Checking the gas type .....	31	<b>E</b>	<b>Overview of fault codes</b> .....	<b>51</b>
			<b>F</b>	<b>Wiring diagram: Combi boiler</b> .....	<b>54</b>
			<b>G</b>	<b>Wiring diagram: Combi boiler (35 kW)</b> .....	<b>55</b>
			<b>H</b>	<b>Commissioning Checklist</b> .....	<b>56</b>

<b>I</b>	<b>Pipe lengths for the air/flue pipe .....</b>	<b>60</b>
I.1	Length of the C13 type air/flue pipe.....	60
I.2	Length of the C33 type air/flue pipe.....	60
I.3	Length of the C43 type air/flue pipe.....	60
<b>Index</b>	<b>.....</b>	<b>61</b>

# 1 Safety

## 1 Safety

### 1.1 Intended use

The product is intended as a heat generator for sealed heating installations and for domestic hot water generation.

Improper use of any kind is prohibited.

Intended use also includes the following:

- use of the product only in mobile homes that are made, transported once and permanently situated in Great Britain and Ireland. After the transportation of the mobile home to its destination the complete product must be checked for leak-tightness again
- validity of the product only for Great Britain and Ireland and for the gas types in Great Britain and Ireland as listed on the data plate
- Installing and operating the product only in conjunction with accessories for the air/flue pipe which are listed in the other applicable documents and comply with the type of unit
- Using the product while observing the accompanying operating, installation and maintenance instructions for the product along with all other components of the installation
- Installing and setting up the product while observing the product and system approval
- Observing all inspection and maintenance conditions listed in the instructions
- Installing while observing the IP code

The following is classed as improper use:

- Using the product in vehicles, such as mobile homes or caravans. Units that are not classed as vehicles are those that are installed in a fixed and permanent location (known as "fixed installation").
- Any direct use in industrial or commercial processes
- Any use other than those described in these instructions and any use that goes beyond what is described here

### 1.2 Qualification

The person carrying out the work described here must have completed professional training. The competent person must demonstrably have all of the knowledge, skills and capabilities that are required in order to carry out the work mentioned below.

The following work must only be carried out by competent persons who are sufficiently qualified to do so:

- Set-up
- Dismantling
- Installation
- Start-up
- Inspection and maintenance
- Repair
- Decommissioning
- ▶ Proceed in accordance with current technology.
- ▶ Use the correct tool.

The above-mentioned work must always only be carried out by persons with sufficient qualifications.

This product can be used by children over eight years old and also by persons with limited physical, sensory or mental capabilities or insufficient experience and/or knowledge if they are supervised or have been provided with instructions on how to safely use the product, and they understand the risks resulting from using the product. Children must not play with the product. Cleaning and user maintenance work must not be carried out by children unless they are supervised.

### 1.3 General safety information

The following sections convey important safety information. It is essential to read and observe this information in order to prevent risk of death, risk of injury, material damage or environmental damage.

#### 1.3.1 Risk of death from escaping gas

What to do if you smell gas in the building:

- ▶ Avoid rooms that smell of gas.
- ▶ If possible, open doors and windows fully and ensure adequate ventilation.

- ▶ Do not use naked flames (e.g. lighters, matches).
- ▶ Do not smoke.
- ▶ Do not use any electrical switches, mains plugs, doorbells, telephones or other communication systems in the building.
- ▶ If it is safe to do so, close the emergency control valve or the main isolator.
- ▶ If possible, close the gas stopcock on the product.
- ▶ Warn other occupants in the building by yelling or banging on doors or walls.
- ▶ Leave the building immediately and ensure that others do not enter the building.
- ▶ Notify the gas supply company or the Emergency Service Provider +44 (0) 800 111999 by telephone once you are outside of the building.

### 1.3.2 Flue gas

Flue gases may cause poisoning, while hot flue gases may also cause burns. Flue gases must therefore never be allowed to escape uncontrollably.

What to do if you smell flue gas in the property:

- ▶ Open all accessible doors and windows fully to provide ventilation.
- ▶ Switch off the product.
- ▶ Check the flue gas routes in the product and the flue gas diversions.

To prevent flue gas exit:

- ▶ Only operate the product if the air/flue pipe has been completely installed.
- ▶ With the exception of short periods for testing purposes, only operate the product when the front casing is installed and closed.
- ▶ If you operate the product with an empty condensate trap / siphon, then flue gas may escape into the room air.
- ▶ In order to operate the product, ensure that the condensate trap / siphon is always full.

To ensure that the seals are not damaged:

- ▶ Instead of grease, use only water or commercially available soft soap to aid installation.

### 1.3.3 Air supply

Unsuitable or insufficient combustion and room air may lead to material damage, but also to life-threatening situations.

To ensure that the combustion air supply is sufficient during open-flued operation:

- ▶ Ensure that the air supply to the product's installation room is permanently unobstructed and sufficient in accordance with the relevant ventilation requirements. This also applies, in particular, for cupboard installations.

To prevent corrosion on the product and in the flue system:

- ▶ Ensure that the combustion air supply is free from sprays, solvents, chlorinated cleaning agents, paint, adhesives, ammonia compounds, dust or similar substances.
- ▶ Ensure that no chemical substances are stored at the installation site.
- ▶ If you are installing the product in hairdressing salons, painter's or joiner's workshops, cleaning businesses or similar locations, choose a separate installation room in which the room air is technically free of chemical substances.

### 1.3.4 Electricity

The power supply terminals L and N remain live even if the unit main switch is switched off.

To prevent electric shocks, proceed as follows before working on the product:

- ▶ Disconnect the product from the power supply by switching off all power supplies at all poles (electrical partition with a contact gap of at least 3 mm, e.g. fuse or circuit breaker) or remove the mains plug (if present).
- ▶ Secure against being switched back on again.
- ▶ Wait at least three minutes until the condensers have discharged.
- ▶ Check that there is no voltage.

### 1.3.5 Weight

To prevent injuries when transporting the product:

# 1 Safety

- ▶ Make sure that the product is transported by at least two people.

## 1.3.6 Explosive and flammable substances

To prevent explosions and fire:

- ▶ Do not use the product in storage rooms that contain explosive or flammable substances (such as petrol, paper or paint).

## 1.3.7 High temperatures

To prevent burns:

- ▶ Only carry out work on components once they have cooled down.

To prevent material damage that is caused by heat transfer:

- ▶ Only solder connectors if the connectors are not yet screwed to the service valves.

## 1.3.8 Heating water

Both unsuitable heating water and air in the heating water may cause material damage to the product and in the heat generator circuit.

- ▶ Check the quality of the heating water. (→ Page 29)
- ▶ If you use non-diffusion-tight plastic pipes in the heating installation, ensure that no air gets into the heat generator circuit.

## 1.3.9 Neutralisation device

To prevent contamination of the waste water:

- ▶ Check whether a neutralising unit must be installed in accordance with national regulations.
- ▶ Observe local regulations on neutralising condensate.

## 1.3.10 Safety devices

- ▶ Install the necessary safety devices in the installation.

## 1.3.11 Risk of death from escaping flue gas

If you operate the product with an empty condensate trap / siphon, then flue gas may escape into the room air.

- ▶ In order to operate the product, ensure that the condensate trap / siphon is always full.

## 1.4 Regulations (directives, laws, standards)

- ▶ Observe the national regulations, standards, directives, ordinances and laws.

## 1.5 List of relevant standards for Great Britain and Ireland



- ▶ You can find a list of relevant standards at <https://www.glow-worm.co.uk/standards>.

## 2 Guarantee and Customer Service

### Guarantee Registration

Thank you for installing a new Glow-worm appliance in your home. Glow-worm appliances are manufactured to the very highest standard so we are pleased to offer our customers a comprehensive guarantee.

To maintain your guarantee, the boiler must be serviced annually by a competent person who holds the required qualifications in accordance with the rules in force of the country where the product is installed and in accordance with the manufactures recommendations.

We recommend you complete your guarantee registration as soon as possible.

#### **Sales Support:**

Telephone: 0345 602 0262

#### **Technical Enquiries:**

Telephone: 01773 828300

Email: [technical@glow-worm.co.uk](mailto:technical@glow-worm.co.uk)

#### **General Enquiries:**

Telephone: 01773 828100

#### **Training Enquiries:**

Telephone: 0345 601 8885

Email: [training.enquiries@vaillant-group.com](mailto:training.enquiries@vaillant-group.com)

#### **Spares Enquiries:**

Telephone: 01773 881383

#### **To register your Glow-worm appliance visit:**

<https://self-service.glow-worm.co.uk/warranty-registration>



Glow-worm is a licensed member of the Benchmark Scheme. Benchmark places responsibilities on both manufacturers and installers. The purpose is to ensure that customers are provided with the correct equipment for their needs, that it is installed, commissioned and serviced in accordance with the manufacturer's instructions by a competent person approved at the time by the Health and Safety Executive and that it meets the requirements of the appropriate Building Regulations.

The Benchmark Checklist can be used to demonstrate compliance with Building Regulations and should be provided to the customer for future reference.

Installers are required to carry out installation, commissioning and servicing work in accordance with the Benchmark Code of Practice which is available from the Heating and Hotwater Industry Council who manage and promote the Scheme.

Benchmark is managed and promoted by the Heating and Hotwater Industry Council.



## 3 Technical data

### 3 Technical data

#### Technical data – General

	Energy7 25c -A (H-GB)	Energy7 30c -A (H-GB)	Energy7 35c -A (H-GB)
Gas category	I <sub>2H</sub>	I <sub>2H</sub>	I <sub>2H</sub>
Diameter of the gas pipe	1/2 inch	1/2 inch	1/2 inch
Diameter of the heating connections	3/4 inch	3/4 inch	3/4 inch
Expansion relief valve connection pipe (min.)	15 mm	15 mm	15 mm
Condensate discharge pipe (min.)	21.5 mm	21.5 mm	21.5 mm
G20 gas supply pressure	2.0 kPa (20.0 mbar)	2.0 kPa (20.0 mbar)	2.0 kPa (20.0 mbar)
Gas flow at P max. – domestic hot water (G20)	2.7 m <sup>3</sup> /h	3.2 m <sup>3</sup> /h	3.8 m <sup>3</sup> /h
Gas flow at P max. – heating mode (G20)	1.9 m <sup>3</sup> /h	2.7 m <sup>3</sup> /h	2.7 m <sup>3</sup> /h
Gas flow at P min. (G20)	0.540 m <sup>3</sup> /h	0.646 m <sup>3</sup> /h	0.762 m <sup>3</sup> /h
CE number (PIN)	CE-0063CP3646	CE-0063CP3646	CE-0063CP3646
Flue gas mass flow rate in heating mode at P min.	2.34 g/s	2.80 g/s	3.30 g/s
Flue gas mass flow rate in heating mode at P max.	8.3 g/s	11.5 g/s	11.6 g/s
Flue gas mass flow rate in domestic hot water mode at P max.	11.6 g/s	13.8 g/s	16.1 g/s
Flue gas temperature (80 °C/60 °C) at P max.	60 °C	77 °C	82 °C
Flue gas temperature (80 °C/60 °C) at P min.	55 °C	55 °C	56 °C
Flue gas temperature (50 °C/30 °C) at P max.	51 °C	62 °C	56 °C
Flue gas temperature (50 °C/30 °C) at P min.	34 °C	35 °C	37 °C
Flue gas temperature in domestic hot water mode	69 °C	68 °C	75 °C
Flue gas temperature when overheating	105 °C	95 °C	104 °C
Released system types	C13, C33, C43, C53	C13, C33, C43, C53	C13, C33, C43, C53
Nominal efficiency at 80/60 °C	99.6 %	99.6 %	99.6 %
Nominal efficiency at 50/30 °C	104.0 %	104.0 %	104.0 %
Nominal efficiency at 40/30 °C	106.0 %	106.0 %	106.0 %
Nominal efficiency in partial load mode (30%) at 40/30 °C	108.5 %	108.5 %	108.5 %
NOx class	6	6	6
Product dimensions, width	390 mm	390 mm	390 mm
Product dimensions, depth	280 mm	280 mm	280 mm
Product dimensions, height	702 mm	702 mm	702 mm
Net weight	32 kg	33 kg	33 kg
Weight when filled with water	36 kg	38 kg	38 kg

#### Technical data – G20 power/load G20

The lowest nominal heat output may be higher than the value in the technical data, depending on the design of the installation and the current operating mode.

	Energy7 25c -A (H-GB)	Energy7 30c -A (H-GB)	Energy7 35c -A (H-GB)
Maximum heat output	18 kW	25 kW	25 kW
Effective output range (P) at 40/30 °C	5.4 to 19.5 kW	6.5 to 27.0 kW	7.6 to 27.2 kW
Effective output range (P) at 50/30 °C	5.3 to 19.1 kW	6.3 to 26.5 kW	7.5 to 26.7 kW
Effective output range (P) at 80/60 °C	5.1 to 18.2 kW	6.1 to 25.2 kW	7.2 to 25.5 kW
Domestic hot water heat output (P)	5.0 to 25.2 kW	6.0 to 30.0 kW	7.1 to 35.0 kW
Maximum heat input – heating (Q max.)	18.4 kW	25.5 kW	25.7 kW
Minimum heat input – heating (Q min.)	5.1 kW	6.1 kW	7.2 kW
Maximum heat input – domestic hot water (Q max.)	25.7 kW	30.6 kW	35.7 kW
Minimum heat input – domestic hot water (Q min.)	5.1 kW	6.1 kW	7.2 kW

### Technical data – Heating

	Energy7 25c -A (H-GB)	Energy7 30c -A (H-GB)	Energy7 35c -A (H-GB)
Max. flow temperature adjustment range (default setting: 75 °C)	10 to 80 °C	10 to 80 °C	10 to 80 °C
Maximum permissible pressure	0.25 MPa (2.50 bar)	0.25 MPa (2.50 bar)	0.25 MPa (2.50 bar)
Nominal water flow ( $\Delta T = 20$ K)	788 l/h	1,094 l/h	1,102 l/h
Nominal water flow ( $\Delta T = 30$ K)	525 l/h	729 l/h	876 l/h
Approximate value for the condensate volume (pH value between 3.5 and 4.0) at 50/30 °C	1.84 l/h	2.55 l/h	2.57 l/h
$\Delta P$ heating at nominal flow ( $\Delta T = 20$ K)	0.025 MPa (0.250 bar)	0.025 MPa (0.250 bar)	0.018 MPa (0.180 bar)

### Technical data – Domestic hot water

	Energy7 25c -A (H-GB)	Energy7 30c -A (H-GB)	Energy7 35c -A (H-GB)
Specific flow rate (D) ( $\Delta T = 30$ K) in accordance with EN 13203	12.1 l/min	14.2 l/min	16.5 l/min
Continuous flow rate ( $\Delta T = 35$ K)	622 l/h	730 l/h	849 l/h
Specific flow rate ( $\Delta T = 35$ K)	10.4 l/min	12.2 l/min	14.1 l/min
Minimum permissible pressure	0.03 MPa (0.30 bar)	0.03 MPa (0.30 bar)	0.03 MPa (0.30 bar)
Maximum permissible pressure	1 MPa (10 bar)	1 MPa (10 bar)	1 MPa (10 bar)
Recommended pressure	0.2 MPa (2.0 bar)	0.2 MPa (2.0 bar)	0.2 MPa (2.0 bar)
Temperature range	35 to 60 °C	35 to 60 °C	35 to 60 °C
Flow rate limiter	8.0 l/min	10.0 l/min	12.0 l/min

### Technical data – Electrics

	Energy7 25c -A (H-GB)	Energy7 30c -A (H-GB)	Energy7 35c -A (H-GB)
Electrical connection	230 V / 50 Hz	230 V / 50 Hz	230 V / 50 Hz
Built-in fuse (slow-blow)	T2/2A, 250V	T2/2A, 250V	T2/2A, 250V
Max. electrical power consumption	66 W	75 W	60 W

### 3 Technical data

	Energy7 25c -A (H-GB)	Energy7 30c -A (H-GB)	Energy7 35c -A (H-GB)
<b>Standby electrical power consumption</b>	2 W	2 W	3 W
<b>IP rating</b>	IPX4D	IPX4D	IPX4D

## 4 Notes on the documentation

- ▶ Always observe all operating instructions enclosed with the installation components.
- ▶ Store these instructions and all other applicable documents for further use.

These instructions apply only to:

### Product article number

	Article number	Gas Council Number
<b>Energy7 25c -A (H-GB)</b>	0010035896	47-019-60
<b>Energy7 30c -A (H-GB)</b>	0010035897	47-019-61
<b>Energy7 35c -A (H-GB)</b>	0010035898	47-019-62

## 5 Product description

### 5 Product description

#### 5.1 CE marking



The CE marking shows that the products comply with the basic requirements of the applicable directives as stated on the declaration of conformity.

The declaration of conformity can be viewed at the manufacturer's site.

#### 5.2 Benchmark

Glow-worm is a licensed member of the Benchmark Scheme.

Benchmark places responsibilities on both manufacturers and installers. The purpose is to ensure that customers are provided with the correct equipment for their needs, that it is installed, commissioned and serviced in accordance with the manufacturer's instructions by a competent person approved at the time by the Health and Safety Executive and that it meets the requirements of the appropriate Building Regulations. The Benchmark Checklist can be used to demonstrate compliance with Building Regulations and should be provided to the customer for future reference.

Installers are required to carry out installation, commissioning and servicing work in accordance with the Benchmark Code of Practice which is available from the Heating and Hotwater Industry Council who manage and promote the Scheme.

Benchmark is managed and promoted by the Heating and Hotwater Industry Council.



For more information visit [www.centralheating.co.uk](http://www.centralheating.co.uk)

#### 5.3 Information on the data plate

The data plate is mounted on the underside of the product at the factory.

The data plate keeps record of the country in which the product is to be installed.

Information on the data plate	Meaning
	Barcode with serial number

Information on the data plate	Meaning
Serial number	For quality control purposes; 3rd and 4th digits = year of production For quality control purposes; 5th and 6th digits = week of production For identification purposes; 7th to 16th digits = product article number For quality control purposes; 17th to 20th digits = place of manufacture
Energy <sub>7</sub> ..c	Product designation
2H, G20 – 2.0 kPa (20 mbar)	Factory setting for gas type and gas connection pressure
Cat.	Unit category
Condensing technology	Efficiency class of the boiler in accordance with EC Directive 92/42/EEC
Type: Xx3(x)	Permissible flue gas connections
PMS	Maximum water pressure in heating mode
PMW	Maximum water pressure in domestic hot water mode
V / Hz	Electrical connection
W	Max. electrical power consumption
IP	IP rating
	Heating mode
P <sub>n</sub>	Nominal heat output range in heating mode
P <sub>nc</sub>	Nominal heat output range in heating mode (condensing technology)
P	Nominal heat output range in domestic hot water mode
Q <sub>n</sub>	Nominal heat input range in heating mode
Q <sub>nw</sub>	Nominal heat input range in domestic hot water mode
T <sub>max.</sub>	Max. flow temperature
NO <sub>x</sub>	NO <sub>x</sub> class for the product
Code (DSN)	Specific product code
	Read the instructions.
GC no.	Gas council number

## 5.4 Functional elements: Combi boiler

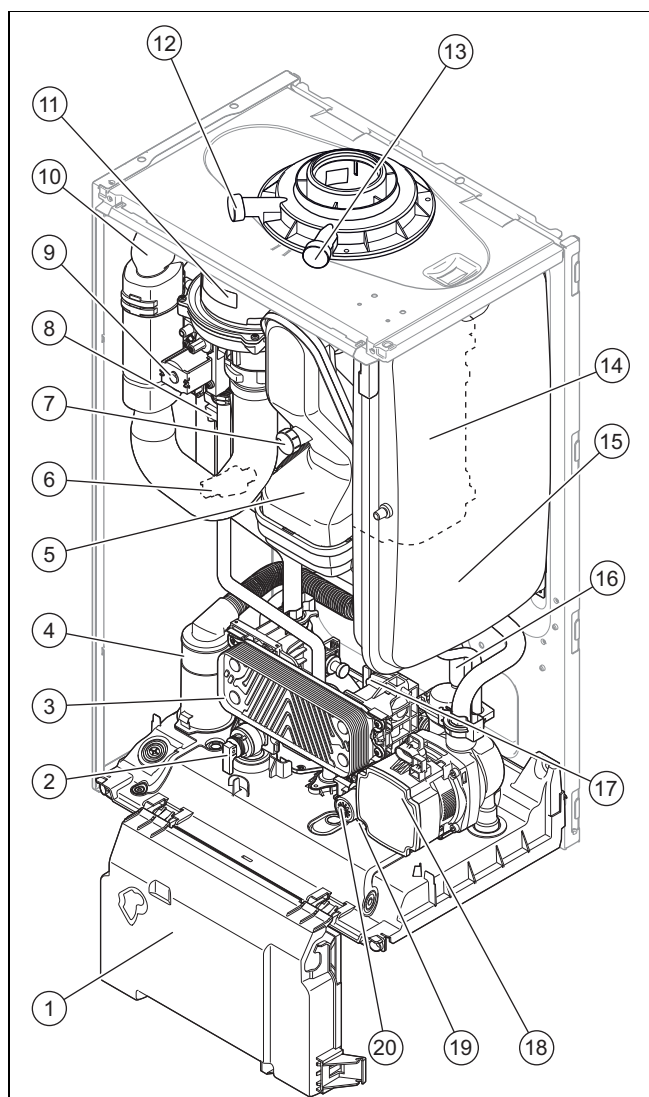

- |    |   |    |  |
|----|---|----|--|
| 1  | Electronics box                             | 11 | Fan  |
| 2  | Heating circuit expansion relief valve      | 12 | Supply air test point (for the top flue)   |
| 3  | Plate heat exchanger                        | 13 | Flue gas analysis point (for the top flue) |
| 4  | Condensate siphon                           | 14 | Primary heat exchanger                     |
| 5  | Flue pipe                                   | 15 | Heating expansion vessel                   |
| 6  | Pressure sensor                             | 16 | Purging hose                               |
| 7  | Flue gas analysis point (for the rear flue) | 17 | Volume flow sensor                         |
| 8  | Ignition transformer                        | 18 | Heating pump                               |
| 9  | Gas valve assembly                          | 19 | Bypass                                     |
| 10 | Air intake pipe                             | 20 | 3-port motorised valve                     |

## 5.5 Safety Devices

### 5.5.1 Electrical Supply Failure

The boiler will not work without an electrical supply. Normal operation of the boiler should resume when the electrical supply is restored.

Reset any external controls, to resume normal operation of the central heating.

If the boiler does not resume normal operation press the reset button. If the boiler does not resume normal operation after this call your Installation/ Servicing company or Vaillant service.

### 5.5.2 Overheating Safety

The boiler software is designed to recognise the potential for an overheat lockout and will shutdown before this happens. To restart the boiler, press the reset button on the boiler interface.

If the boiler fails to resume normal operation and all external controls are calling for heat, then call your Installation/ Servicing company or Vaillant service.

### 5.5.3 Frost protection

The appliance has a built in frost protection device that protects the boiler from freezing. With the gas and electric supplies ON and irrespective of any room thermostat setting, the frost protection device will operate the pump when the temperature of the boiler water falls below 12 °C.

A timer is used so that the temperature can be checked periodically. After 10 minutes the pump will be stopped if the temperature is higher than 10 °C or has already reached 35 °C. The burner will activate if the boiler temperature does not reach 10 °C after 30 minutes or at any time if the temperature drops to 5 °C.

The burner will switch off when the temperature reaches 35 °C.

### 5.5.4 Condensate Drain Blockage

As a safety feature the boiler will stop working if the condensate drain becomes blocked. During freezing conditions this may be due to the forming of ice in the condensate drain external to the house. Release an ice blockage by the use of warm cloths on the pipe. After pressing reset the boiler should restart.

## 6 Set-up

### 6 Set-up

#### 6.1 Unpacking the product

1. Remove the product from its box.
2. Remove the protective film from all of the product's components.

#### 6.2 Checking the scope of delivery

- Check that the scope of delivery is complete and intact.

Number	Designation
1	Heat generator
1	Unit mounting bracket
1	Flexible condensate discharge pipe
6	3/4" seals
4	1/2" seals
1	Service valve
1	Gas stopcock
1	Filling device
2	Connection pipe (heating flow and return)
1	Cold water connection pipe
1	Domestic hot water connection pipe
1	Gas pipe
1	Expansion relief valve drain pipe
1	Mounting template
1	Enclosed documentation

### 6.3 Dimensions

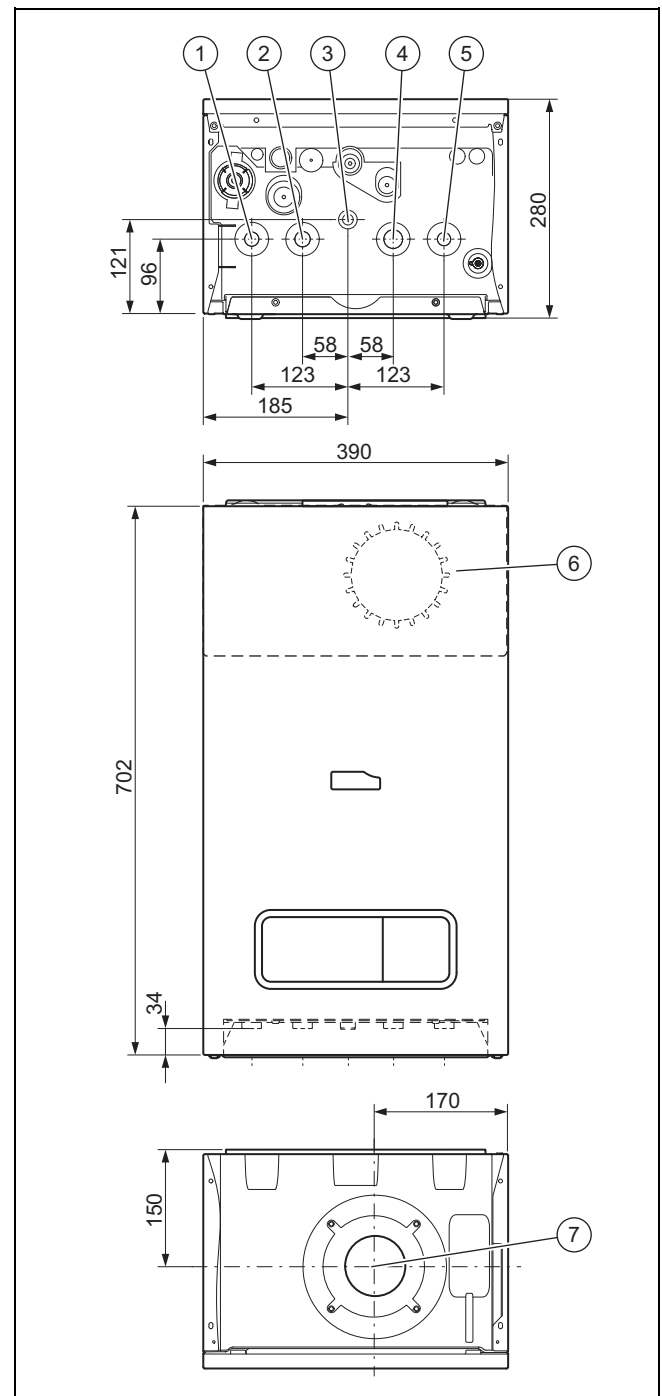

- |   |                               |   |                               |
|---|-------------------------------|---|-------------------------------|
| 1 | Heating flow                  | 5 | Heating return                |
| 2 | Domestic hot water connection | 6 | Rear air/flue pipe connection |
| 3 | Gas connection                | 7 | Top air/flue pipe connection  |
| 4 | Cold water connection         |   |                               |

## 6.4 Installation site

This boiler is not suitable for outdoor installation. This boiler may be installed in any room. However if the boiler is being installed in a room containing a bath or shower it must only be installed in zones 2 or 3. In GB this is the current I.E.E. WIRING REGULATIONS and BUILDING REGULATIONS. In IE reference should be made to the current edition of I.S.813 "Domestic Gas Installations" and the current ETCI rules.

If the boiler is to be installed in a timber frame building it should be fitted in accordance with the current version of the Institute of Gas Engineers document IGE/UP/7. If in doubt seek advice from local gas undertaking or the manufacturer.

## 6.5 Minimum clearances

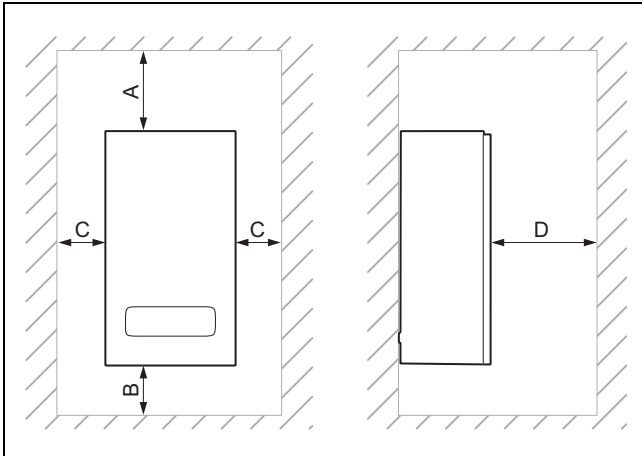

	Minimum clearance
A	150 mm (top air/flue connection) 20 mm (rear air/flue connection)
B	150 mm
C	5 mm (70 mm if the side sections ought to be removed)
D	600 mm

The boiler and flue are suitable for installation onto and through combustible materials provided that:

1. Minimum 5 mm clearance is maintained around the circumference of the flue (air intake).
2. The combustible surface and fixings are suitable for supporting the load.
3. The minimum clearances from the boiler case are maintained.

## 6.6 Compartment Ventilation

The boilers are very high efficiency appliances.

As a consequence the heat loss from the appliance casing during operation is very low.

Compartment ventilation is not required as the products are only certified, and can only be fitted with a concentric flue system.

## 6.7 Air/flue pipe

### 6.7.1 Regulation

Different flue outlet configurations can be carried out.

- Consult the installation manual for air/flue gas systems for more information about the other possibilities and associated accessories.

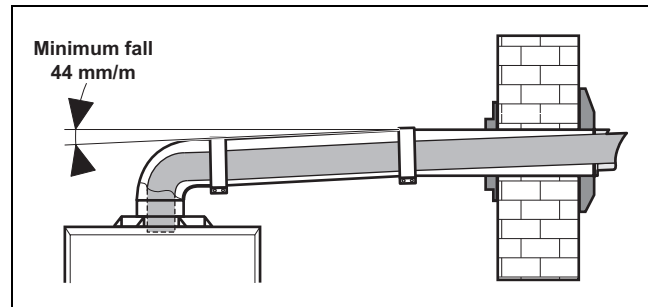

- Standard flue terminal kits have an in-built fall back to the boiler to drain the condensate. These can be fitted level between the appliance and the termination position. All other extended flues must have a fall of at least 44 mm/m.

The maximum length of the flue outlet is defined according to its type (for example C13).

- Whatever the kind of flue system chosen, observe the minimum distances to position the flue terminals.
- To install the flue, refer to the separate flue instruction supplied with your appliance.
- Explain these requirements to the user of the appliance.

In GB the minimum acceptable siting dimensions for the terminal from obstructions, other terminals and ventilation openings are shown in diagram overleaf.

In IE the minimum distances for flue terminal positioning must be those detailed in I.S. 813 "Domestic Gas Installations".

The terminal must be exposed to the external air, allowing free passage of air across it at all times.

Being a condensing boiler some plumbing may occur from the flue outlet. This should be taken into consideration when selecting the position for the terminal.

### 6.7.2 Terminal protection

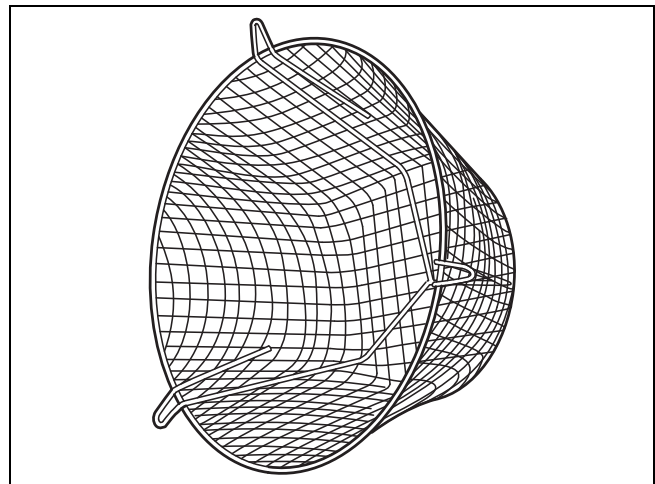

## 6 Set-up

A terminal guard is required if persons could come into contact with the terminal or the terminal could be subject to damage.

If a terminal guard is required, it must be positioned to provide minimum of 50 mm clearance from any part of the terminal and be central over the terminal.

The guard should be similar to that shown in the figure.

### 6.7.3 Position of the air/flue terminal

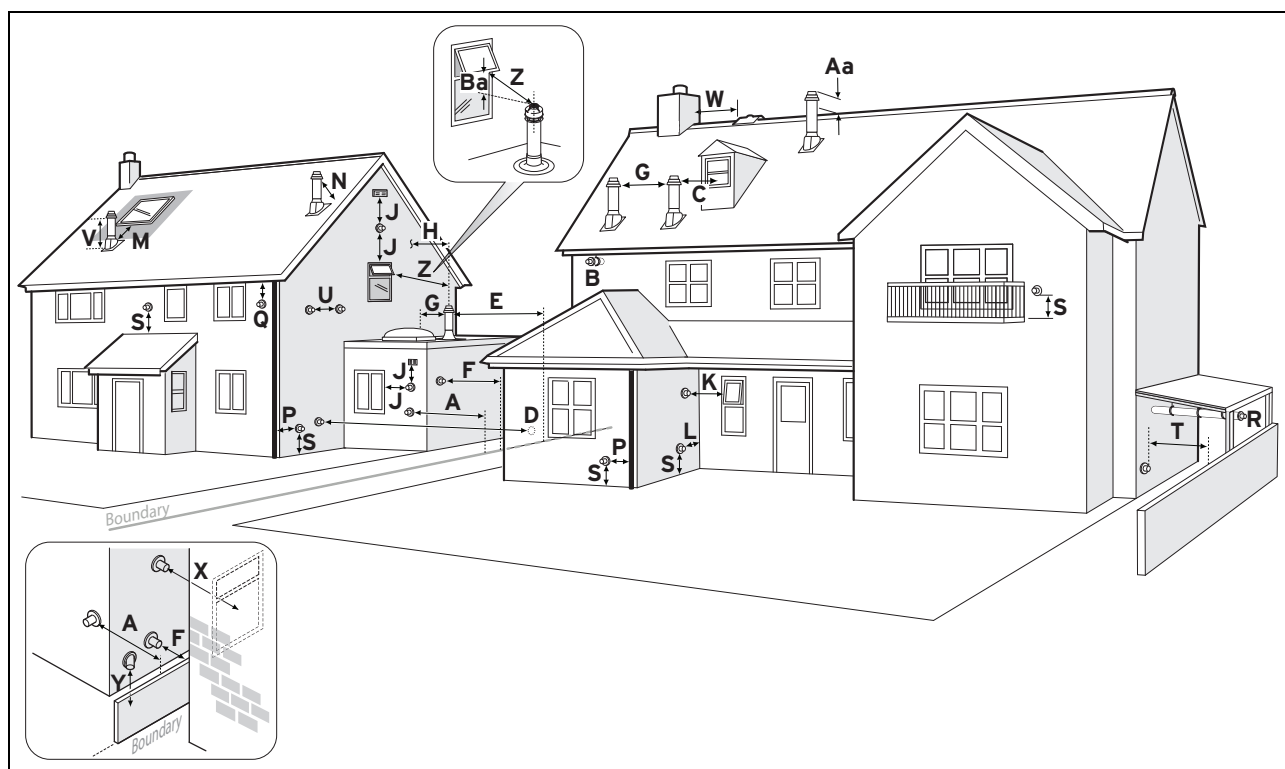

#### 6.7.3.1 Positioning the terminal of a fan-supported flue system

	Installation site	Dimensions
A	Adjacent to a boundary.	300 mm
B <sup>1)</sup>	The dimension below eaves, balconies and car ports can be reduced to this value, as long as the flue terminal is extended to clear any overhang. External flue joints must be sealed with a suitable silicon sealant.	25 mm
C	Between a vertical flue terminal and a window or dormer window on a roof.	1,500 mm
D	Between terminals facing each other.	1,200 mm
E	Vertical flue clearance, adjacent to a boundary line.	300 mm
F <sup>2)</sup>	Distance to a boundary line, unless it will cause a nuisance. BS 5440:Part 1 recommends that care is taken when siting terminal in relation to boundary lines.	600 mm
G	Minimum clearance from a skylight to a vertical flue or to another vertical flue.	Min. 300 mm
H	Vertical flue clearance, to noncombustible building material. Vertical flue clearance to combustible building material.	500 mm 1,500 mm
J	Above, below and either side of an opening door, air vent or opening window.	300 mm
K	Diagonally to an opening door, air vent or opening window.	600 mm
L <sup>2)</sup>	To an internal or external corner.	200 mm
M	Below a Velux window. Above or to either side of the Velux window.	2,000 mm 600 mm
N	From a pitched roof. In regions with heavy snowfall.	400 mm 500 mm
P	From vertical drain pipes and soil pipes.	25 mm
	<p>1) There should be no ventilation/opening in the eaves within 300 mm distance of the terminal.</p> <p>2) These dimensions comply with the building regulations, but they may need to be increased to avoid wall staining and nuisance from pluming depending on site conditions.</p> <ul style="list-style-type: none"> <li>- Terminals must be positioned so to avoid combustion products entering the building.</li> <li>- Support the flue at approximately one metre intervals and at a change of direction, use suitable brackets and fixings.</li> <li>- Installations in car ports are not recommended.</li> <li>- The flue cannot be lower than 1 metre from the top of a lightwell due to the build up of combustion products.</li> <li>- Dimensions from a flue terminal to a fanned air inlet to be determined by the ventilation equipment.</li> </ul>	

## 6 Set-up

	Installation site	Dimensions
Q	Below eaves. Below gutters, pipe and drains.	200 mm 75 mm
R	The dimension below eaves, balconies and car ports can be reduced to this value, as long as the flue terminal is extended to clear any overhang. External flue joints must be sealed with suitable silicon sealant.	25 mm
S	Above adjacent ground or balcony.	300 mm
T <sup>2)</sup>	Distance to a surface facing a terminal, unless it will cause a nuisance. BS 5440: Part 1 recommends that care is taken when siting terminals in relation to surfaces facing a terminal.	600 mm
U	Clearance alongside another terminal.	300 mm
V	Above roof level.	300 mm
W	Minimum to vertical structure on roof, roof vent.	Min. 300 mm
X	Minimum to opening in adjacent building.	Min. 2000 mm
Y	Minimum at an angle to a boundary which is not less than 300 mm to the terminal	Min. 600 mm
Z	Minimum measured to the nearest corner of the OPEN window	Min. 600 mm
Aa	No more than this value above ridge.	Max. 300 mm
Ba	Not less than this value below the opening window	Min. 300 mm
	1) There should be no ventilation/opening in the eaves within 300 mm distance of the terminal. 2) These dimensions comply with the building regulations, but they may need to be increased to avoid wall staining and nuisance from plumbing depending on site conditions. <ul style="list-style-type: none"> <li>- Terminals must be positioned so to avoid combustion products entering the building.</li> <li>- Support the flue at approximately one metre intervals and at a change of direction, use suitable brackets and fixings.</li> <li>- Installations in car ports are not recommended.</li> <li>- The flue cannot be lower than 1 metre from the top of a lightwell due to the build up of combustion products.</li> <li>- Dimensions from a flue terminal to a fanned air inlet to be determined by the ventilation equipment.</li> </ul>	

### 6.7.3.2 Horizontal terminal positioning

BS 5440-1 recommends that fanned flue chimney terminals should be positioned as follows:

- a) at least 2 m from an opening in the building directly opposite, and
- b) so that the products of combustion are not directed to discharge directly across a boundary if the products are likely to cause a nuisance to a neighbour or discharge over a walkway or patio.

For IE see current issue of IS 813.

For boilers covered within this manual.

Dimensions B and R:

These clearances may be reduced to 25 mm without affecting the performance of the boiler. In order to ensure that the condensate plume does not affect adjacent surfaces the terminal should be extended as shown below.

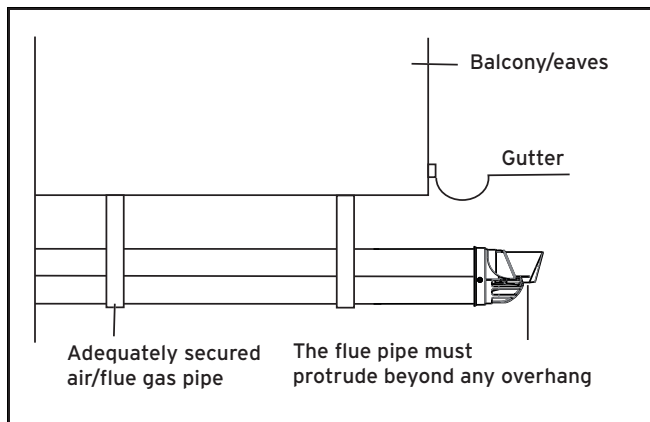

You can use a plume management kit to enable the termination point to be positioned and directed away from the building fabric.

## 6.7.4 Flue Configuration Description

### 6.7.4.1 Horizontal Concentric Flue $\varnothing$ 60/100 mm or $\varnothing$ 80/125 mm (C13 type installation)

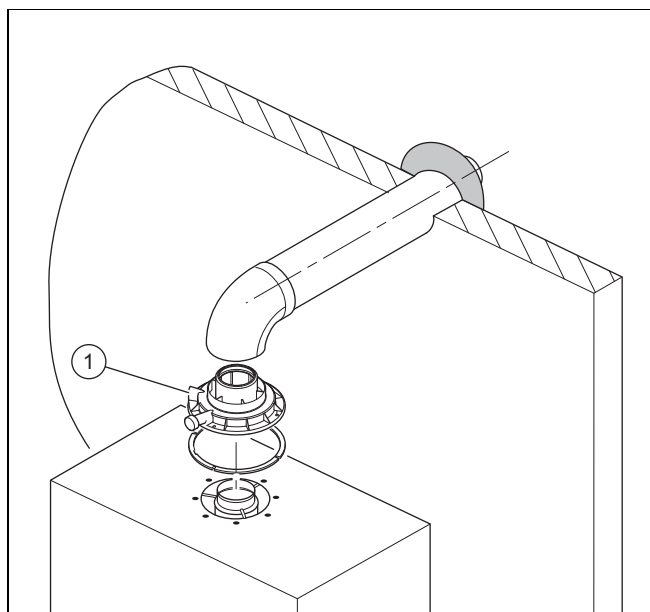

1 Gasket (fitted)



#### Note

If the terminal is at less than 1.80 m from the ground, you must install a terminal protection kit.

Type	Max. length (L)	Height (H)
60/100 diameter	10 m	76 mm
80/125 diameter	25 m	169 mm

Each time an additional 90° bend is necessary (or 2 at 45°), the length (L) must be reduced by 1 m.

### 6.7.4.2 Vertical Concentric Flue $\varnothing$ 60/100 mm or $\varnothing$ 80/125 mm (C33 type installation)

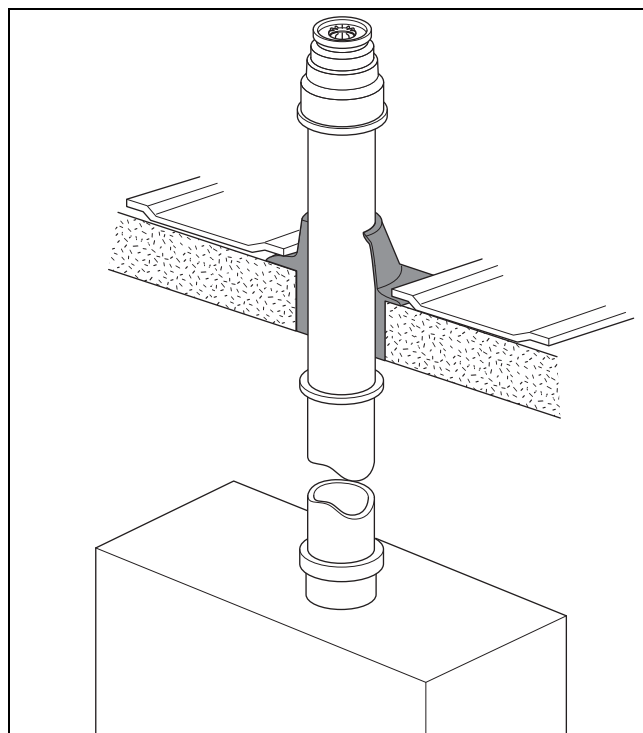

Consult the separate installation manual for air/flue gas systems supplied with your appliance for all possibilities and associated accessories and how to install the flue system.

## 6 Set-up

### 6.7.4.3 Multiple boiler chimney Flue $\varnothing$ 60/100 mm (C43 type installation)

#### 6.7.4.3.1 Multiple Boiler Chimney Flue

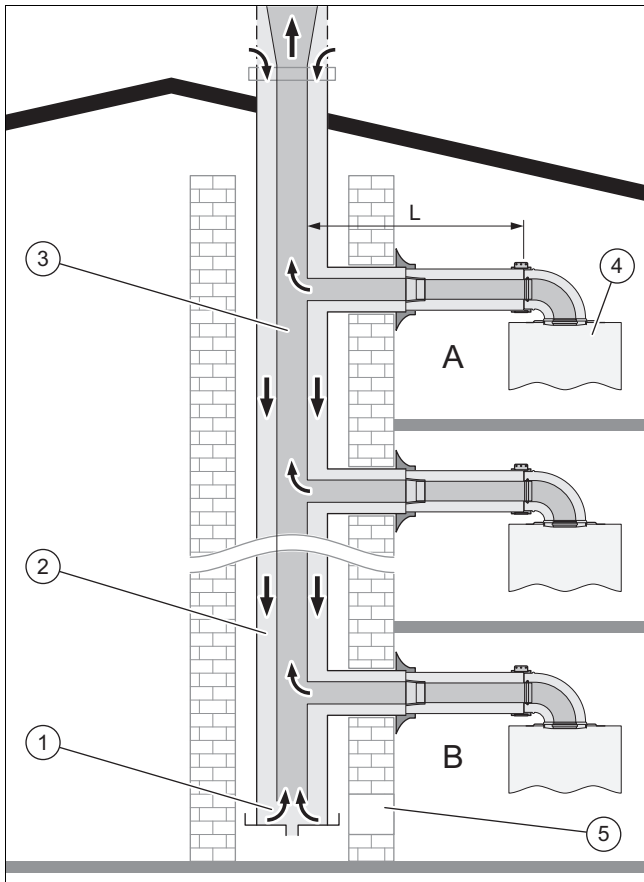

- |   |                           |   |                  |
|---|---------------------------|---|------------------|
| 1 | Pressure balancing system | 4 | Boiler           |
| 2 | Air-inlet pipe            | 5 | Inspection hatch |
| 3 | Collector pipe            | A | Final storey     |
|   |                           | B | Ground floor     |



#### Note

The flue connecting from the appliance to the flue system must be supplied from the manufacturer of the boiler.

C43 flue systems must not be a 'pressurised system' but act under natural draught principles.

C43 type flue systems must have their own condensate drain fitted and not allow condensate to mix into other appliances.

The flue length must be calculated and installed according to the relevant standards EN 13384-1 and 2 (C43 flue systems only) with reference to the table below and the manufacturer's instructions supplied. The appliance maximum flue length must be included when calculating the overall design of the flue system.

Max Flue Length C43 (→ Page 20)

Each time an additional 90° bend is necessary (or 2 at 45°), the length (L) must be reduced by 1 m.

Type	Max. length (L)
60/100 diameter	10 m

### 6.8 Using the mounting template

- ▶ Use the mounting template to ascertain the locations at which you need to drill holes.

### 6.9 Wall-mounting the product



#### Note

If you are using the rear air/flue connection, install the air/flue pipe before you wall-mount the product.

1. Check the load-bearing capacity of the wall.
2. Note the total weight of the product.
3. Only use fixing material that is permitted for the wall.
4. If required, ensure that mounting apparatus on-site has sufficient load-bearing capacity.
5. Wall-mount the product as described.

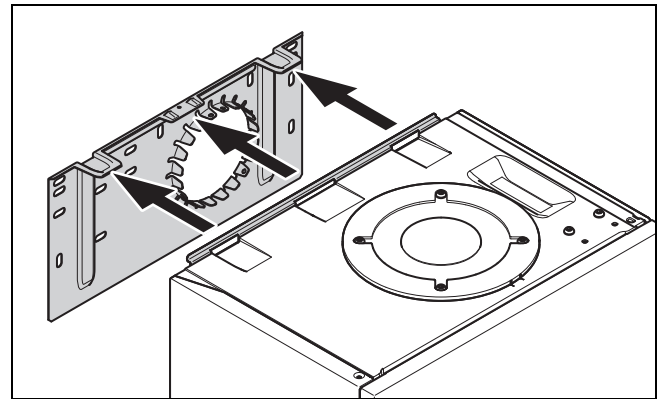

6. Mount the unit mounting bracket on the wall.
7. Hook the product onto the unit mounting bracket.

## 6.10 Removing/installing the front casing

### 6.10.1 Removing the front casing

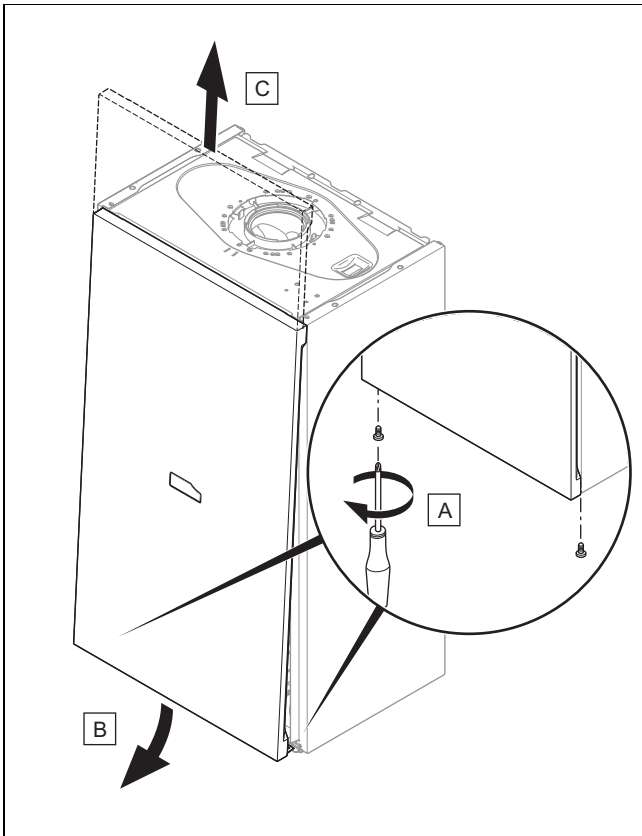

### 6.10.2 Installing the front casing

- ▶ Refit the components in the reverse order.

## 6.11 Removing/installing the side section

### 6.11.1 Removing the side section



#### Caution.

#### Risk of material damage caused by mechanical deformation.

Removing **both** side sections may cause mechanical distortion in the product, which may cause damage to the piping, for example, and potentially result in leaks.

- ▶ Always only remove **one** side section – never both side sections at the same time.



#### Note

If there is sufficient lateral clearance (at least 70 mm), you can remove the side section to facilitate maintenance or repair work.

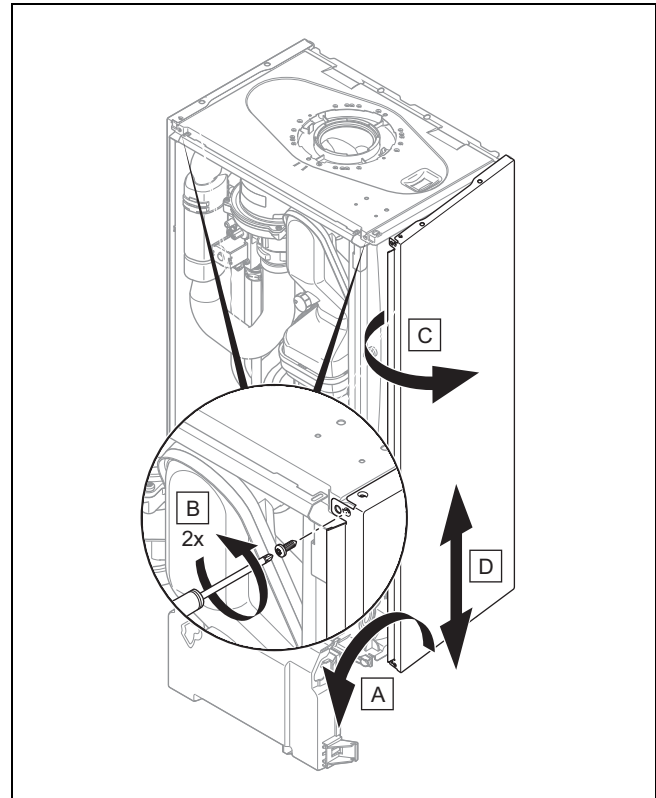

### 6.11.2 Installing the side section

- ▶ Refit the components in the reverse order.

# 7 Installation

## 7 Installation

### 7.1 Preparing for installation

- ▶ Make sure that the existing gas meter and the pipelines are capable of passing the rate of gas supply required.
- ▶ Consider the maximum heat output given in DHW mode.
- ▶ Install the following components:
  - Draining cocks at the lowest points in the heating installation (→ current version of "BS 2879")
  - A bypass that is at least 1.5 m away from the product
  - A stopcock in the gas pipe
  - Where applicable, a flow regulator valve to adjust the flow rate
- ▶ Install the connection pipes such that they are free from mechanical stress.
- ▶ If you use non-diffusion-tight plastic pipes in the heating installation, ensure that no air gets into the heat generator circuit.
- ▶ Only solder connectors if the connectors are not yet screwed to the service valves.
- ▶ Only bend connection pipes if they have not yet been connected to the product.
- ▶ Flush the heating installation thoroughly before installing the product.
- ▶ Check the leak-tightness of the gas valve assembly using a pressure of  $\leq 11$  kPa (110 mbar).

### 7.2 Flushing the heating installation for the first time ("cold")



#### Note

The complete heating system must be flushed at least twice: Once with cold water and once with hot water in accordance with the following instructions.

1. Check whether all thermostatic radiator valves and both service valves on the product are open.
2. Connect a hose to the drain valve that is located at the lowest position in the heating system.
3. Open the radiator valves and the drain valves so that the water can drain quickly. Start at the next point in the installation and open the purging valves on the radiators so that the contaminated water can completely drain.
4. Close the draining cocks.
5. Refill the heating system with water.
6. Check that the expansion relief valve of the heating system is functioning correctly by turning the handle on the valve.
7. Check the pressure in the heating system and top up with water if necessary.
8. Close the filling valve and the cold water tap.

### 7.3 Checking the gas meter

- ▶ Make sure that the existing gas meter is capable of passing the rate of gas supply required.

### 7.4 Checking the gas flow rate

The gas flow rate has been set during production and does not require adjustment. With the front casing fitted check the gas flow rate of the boiler as follows:

- ▶ Start up the product with the check programme **P.01**.
- ▶ In addition, ensure that maximum heat can be dissipated into the heating system by turning up the room thermostat.
- ▶ Wait at least 5 minutes until the boiler has reached its operating temperature.
- ▶ Ensure that all other gas appliances in the property are turned off.
- ▶ Measure the gas flow rate at the gas meter.
- ▶ Compare the measured values with the corresponding values in the table.

Q <sub>nw</sub> from the data plate	H gas in m <sup>3</sup> /h		
	Nom.	+5%	-10%
15.3	1.62	1.70	1.46
18.4	1.95	2.05	1.76
24.7	2.61	2.74	2.35
25.7	2.72	2.86	2.45
28.6	3.03	3.18	2.73
30.6	3.24	3.40	2.92
35.7	3.78	3.97	3.40

**Condition:** Gas flow rate not in the permissible range

- ▶ Check all of the piping and ensure that the gas flow rates are correct.
- ▶ Only put the product into operation once the gas flow rates have been corrected.

**Condition:** Gas flow rate in the permissible range

- ▶ End the check programme **P.01**.
- ▶ Allow the boiler to cool down by allowing pump overrun to operate for a minimum of 2 minutes.
- ▶ Record the boiler maximum gas flow rate onto the Benchmark gas boiler commissioning checklist.

### 7.5 Gas and water connections



#### Caution.

#### Risk of damage caused by incorrect gas connection installation.

Excess test pressure or operating pressure may cause damage to the gas valve assembly.

- ▶ Check the leak-tightness of the gas valve assembly using a maximum pressure of 11 kPa (110 mbar).



**Caution.**  
**Risk of material damage caused by corrosion**

Due to non-diffusion-tight plastic pipes in the heating installation, air gets into the heating water. Air in the heating water causes corrosion in the heat generator circuit and in the product.

- ▶ If you use non-diffusion-tight plastic pipes in the heating installation, ensure that no air gets into the heat generator circuit.



**Caution.**  
**Risk of material damage due to heat transfer during soldering.**

- ▶ Only solder connectors if the connectors are not yet screwed to the service valves.



**Note**  
Apply heat insulation to the water pipes to the boiler outlet and to the installation.

**Preliminary work**

1. Check that the system volume and the volumetric capacity of the expansion vessel are compatible.
  - ▽ If the volume of the expansion vessel is insufficient for the installation.
    - ▶ Install an additional expansion vessel in the heating return, as close to the product as possible.
    - ▶ Install a non-return valve at the product's outlet (heating flow).
2. Ensure that the installation has the following components:

Working materials
A cold-water stopcock for the unit
A gas stopcock for the unit
A filling/draining device in the heating installation

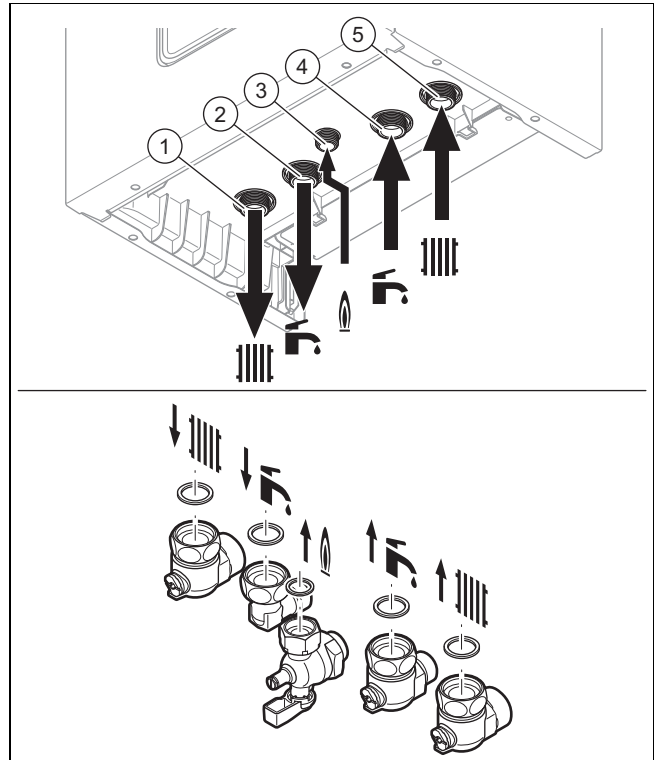

- |                                       |  |
|---------------------------------------|--|
| 1 Heating flow connection, G3/4       | 4 Connection for the cold water pipe, G3/4 |
| 2 Domestic hot water connection, G3/4 | 5 Heating return connection, G3/4          |
| 3 Gas connection, G1/2                |  |

1. Connect the water and gas connections in accordance with the applicable standards.
2. Purge the gas pipe before start-up.
3. Check whether the connections (→ Page 33) are leak-tight.

**7.6 Connecting the drain pipework for the expansion relief valve**

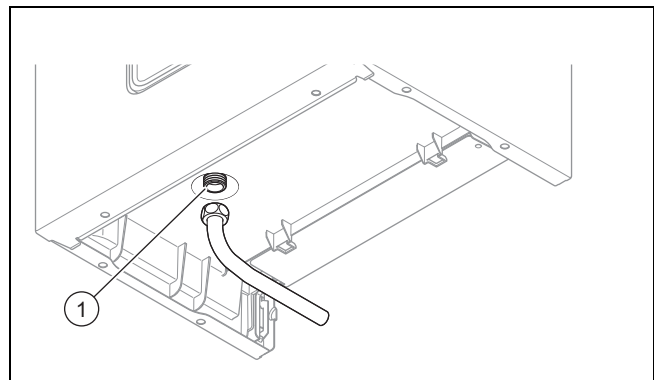

- ▶ Ensure that the pipeline is visible.
- ▶ The pipe must have a continuous fall and be routed to a position so that any discharge of water, possibly boiling, or steam cannot create any danger to persons, damage to property or external electrical components and wiring.
  - ◁ The piping must be installed in such a way that you can see when water drips out.

## 7 Installation

### 7.7 Connecting the condensate discharge pipe

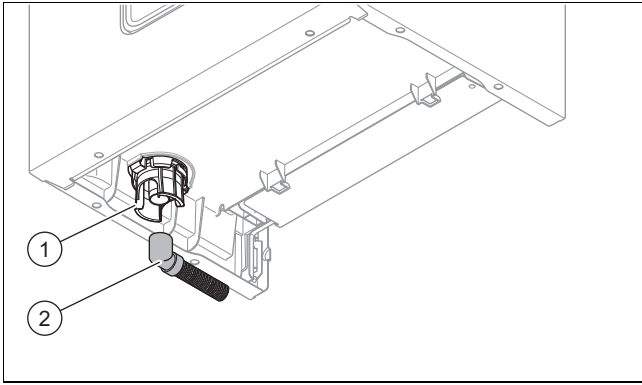

- ▶ Follow the instructions listed here and observe the legal and local regulations on condensate discharge.
- ▶ Use PVC or any other material that is suitable for draining the non-neutralised condensate.
- ▶ If you cannot guarantee that the materials from which the drain pipework is made are suitable, install a system for neutralising the condensate.



#### Note

The condensate drain pipework must have a continuous fall (45 mm per metre) and should whenever possible terminate at a suitable drain point within the heated envelope of the building that will remain frost free under long periods of low external temperatures.

- ▶ Connect the condensate traps (1). Use the supplied drain hose (2) for this.



#### Note

Ensure that the connection between the condensate discharge pipe and the drain hose is not air-tight.

- ▶ Connect a condensate discharge pipe (21.5 mm, not included in the scope of delivery) to the drain hose (2).
- ▶ During installation remove all burrs from inside of cut pipe work and avoid excessive adhesive which may trap small pockets of water close to the pipe wall which can freeze and build into a larger ice plug.
- ▶ For any installation the condensate must be free flowing and not be possible for air back-pressure to prevent water flow.
- ▶ As with other pipe work insulate the condensate discharge pipe to minimise any risk of freezing and beware when crossing cavities that the fall is maintained and the pipe sleeved.

You can find further information in specification "BS 6798" for installing and maintaining gas-fired boilers with a nominal heat input below 70 kW.

#### 7.7.1 Condensate discharge systems

The condensate is discharged periodically in 'slugs' by siphonic action. It is not necessary to provide extra traps in the discharge pipe as there is already a 75 mm high trap inside the boiler. Fitting an extra trap may cause the boiler siphon

to work incorrectly. Refer to BS5546 or BS6798 for further advice on disposal of boiler condensate.

##### 7.7.1.1 Direct Connection to internal soil and vent stack

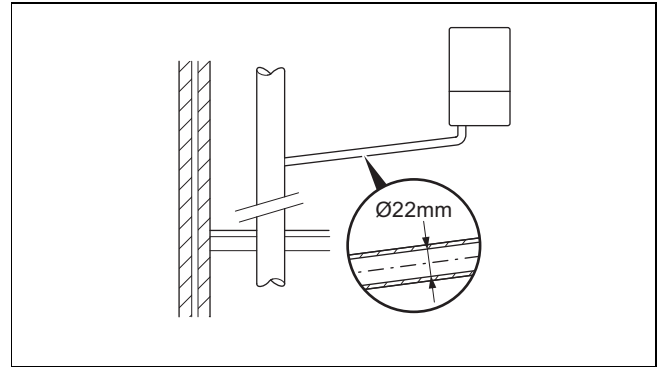

Preferred option

##### 7.7.1.2 Direct connection to external soil and vent stack

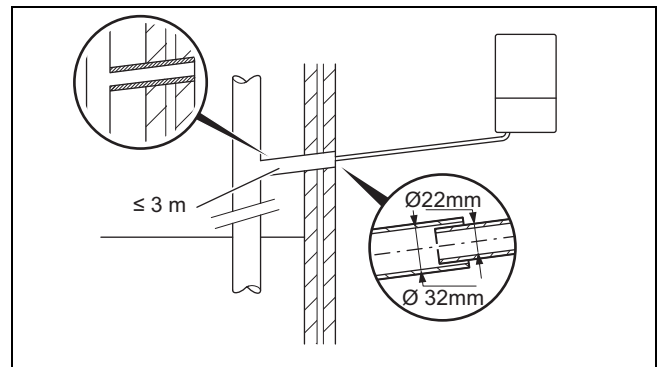

##### 7.7.1.3 External termination to gully or hopper

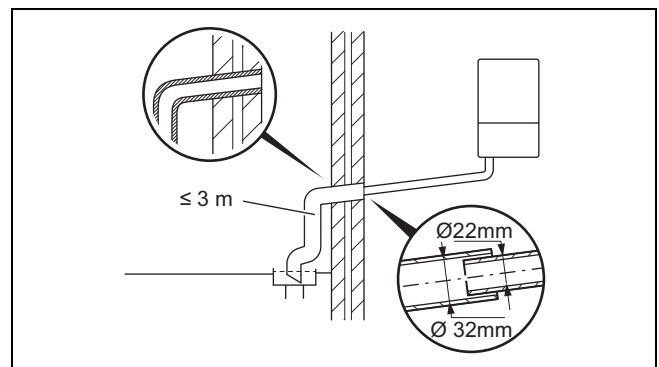

Best practice

## 7.7.1.4 Internal termination into combined sink waste

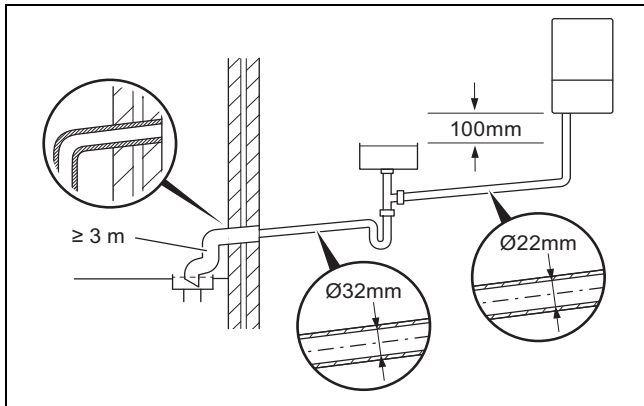

Preferred option for external termination

## 7.7.1.5 External termination into soakaway

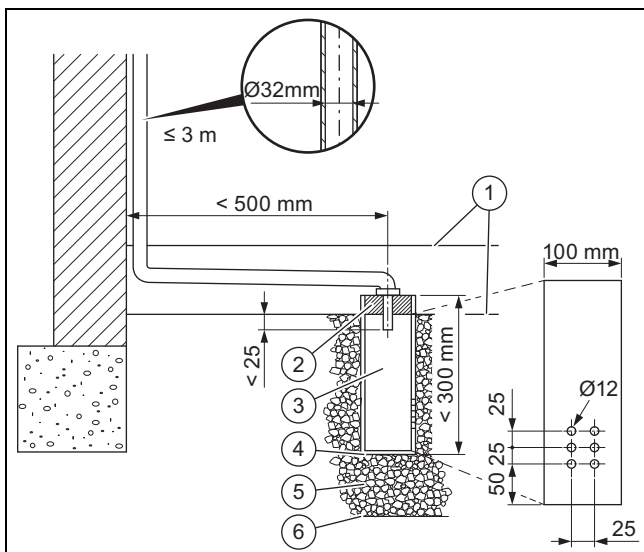

- |                                 |                             |
|---------------------------------|-----------------------------|
| 1 Ground (either/or)            | 4 Bottom of sealed tube     |
| 2 Seal                          | 5 Limestone chippings       |
| 3 Plastic tube, 100 mm diameter | 6 Hole depth 400 mm minimum |

Least preferred option, must not terminate in rain water drain

## 7.7.1.6 Internal termination downstream of sink waste

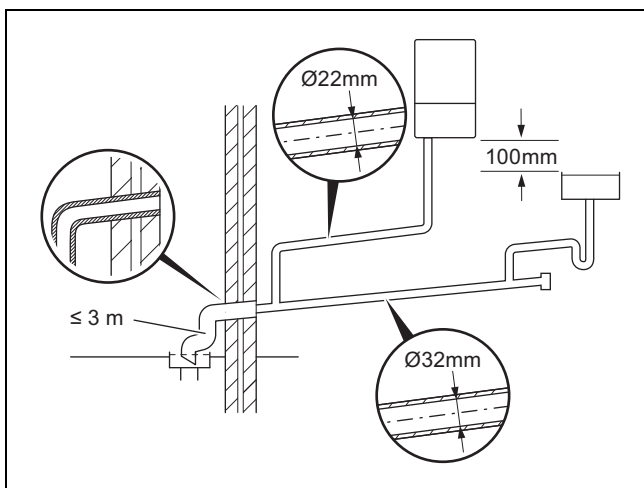

Open end of pipe direct into gully below ground level but above water level

Susceptible to siphonage, must terminate in a gully

## 7.7.1.7 External termination into rain water down pipe

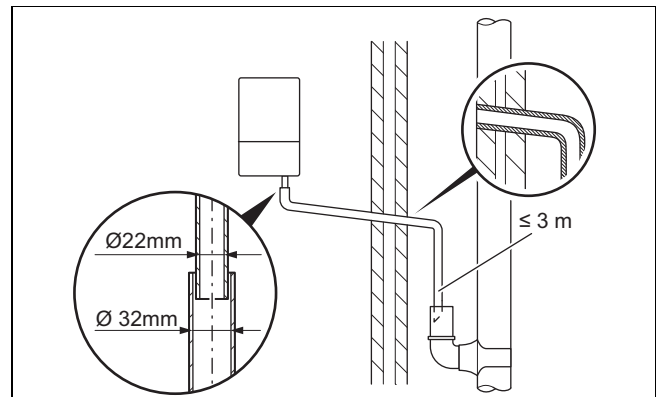

NB only combined foul/rainwater drain

## 7.7.1.8 Additional methods of introducing air breaks

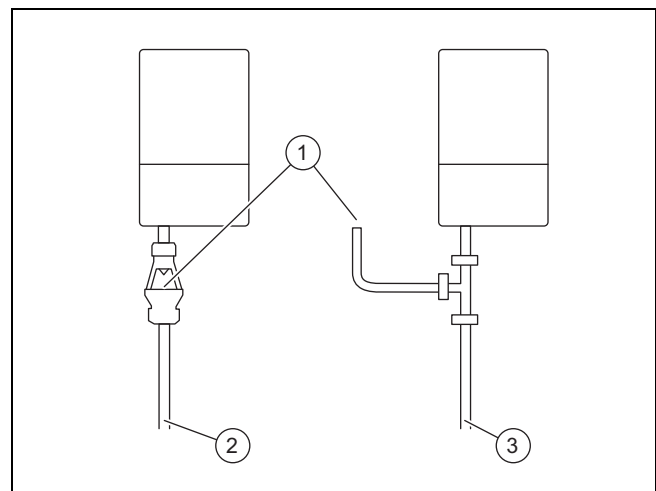

- |                   |                |
|-------------------|----------------|
| 1 Air break       | 3 Using a pipe |
| 2 Using a tundish |                |

## 7.7.1.9 Connection of condensate pump

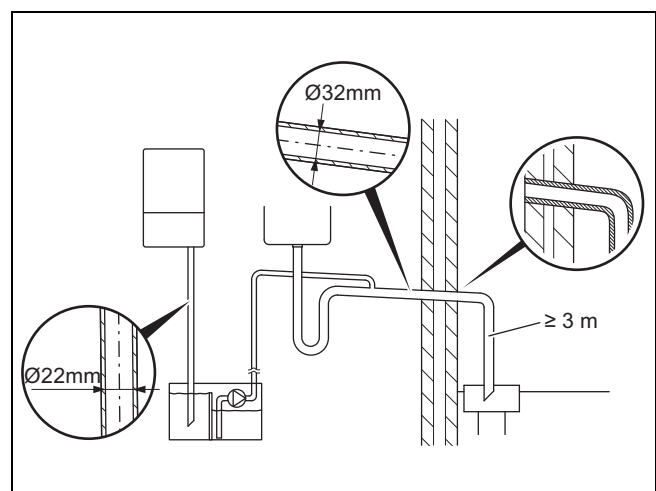

## 7 Installation

Preferred option for external connection

### 7.8 Flue installation

#### 7.8.1 Installing and connecting the air/flue pipe

1. You can find out which air/flue pipes may be used by consulting the enclosed set-up instructions for the air/flue system.
2. Observe the information on positioning the air/flue terminal.

**Condition:** Installation in damp rooms

- ▶ You must connect the product to a room-sealed air/flue system. The combustion air must not be taken from the installation site.

3. Install the air/flue pipe using the set-up instructions.

### 7.9 Electrical installation

Only qualified electricians may carry out the electrical installation.

The product must be earthed.



#### **Danger!** **Risk of death from electric shock!**

The power supply terminals L and N remain live even if the product is switched off:

- ▶ Switch off the power supply.
- ▶ Secure the power supply against being switched back on.

#### 7.9.1 Opening the electronics box

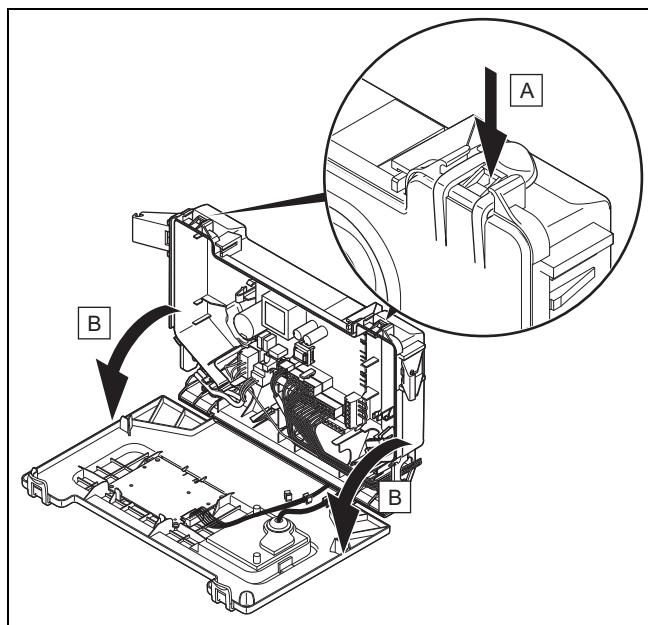

#### 7.9.2 Closing the electronics box

- ▶ Follow the instructions in the reverse order.

#### 7.9.3 Cable route

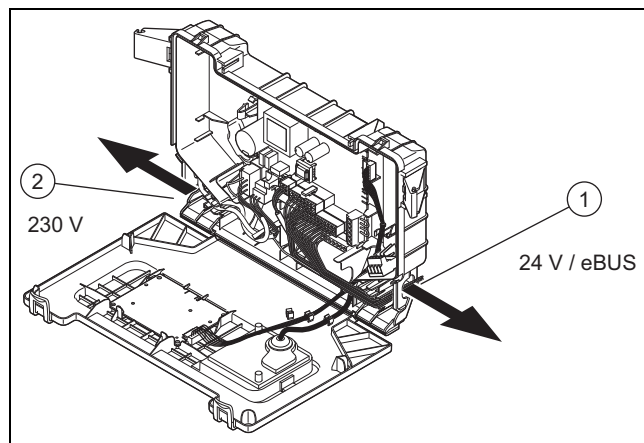

1 24-V eBUS cable route 2 230 V cable route

#### 7.9.4 General information about connecting cables



#### **Caution.** **Risk of material damage caused by incorrect installation.**

Mains voltage at incorrect terminals and plug terminals may destroy the electronics.

- ▶ Do not connect any mains voltage to the eBUS (+/-) and RT 24 V terminals.
- ▶ Only connect the connection cable to the terminals marked for the purpose.

1. Route the connection cables of the components to be connected through the grommet provided on the underside of the product on the left.
2. Ensure that the grommet is plugged in correctly and that the cables have been routed correctly.
3. Ensure that the grommets envelop the connection cables tightly and with no visible gaps.
4. Use strain reliefs.
5. If required, shorten the connection cables.

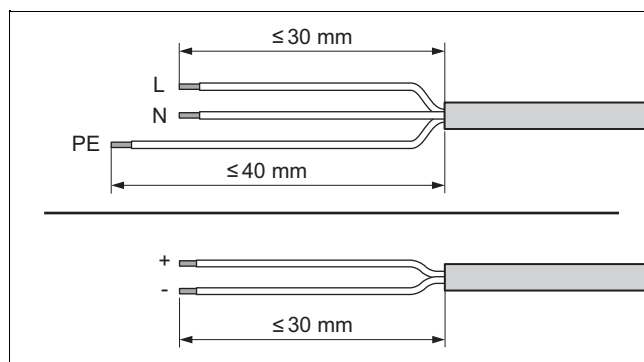

6. Strip the flexible cables as shown in the figure. In doing so, ensure that the insulation on the individual conductors is not damaged.

7. Only strip inner conductors just enough to establish stable connections.
8. To avoid short circuits resulting from loose individual wires, fit conductor end sleeves on the stripped ends of the conductors.
9. Screw the respective plug to the connection cable.
10. Check whether all conductors are inserted mechanically securely in the plug terminals. Remedy this if necessary.
11. Plug the plug into the associated PCB slot.
  - In doing so, observe the wiring diagram in the appendix.

## 7.9.5 Establishing the power supply

1. Make sure that the rated voltage of the mains is 230 V.
2. Provide one common power supply for the boiler and for the corresponding control:
  - Power supply: Single-phase, 230 V, 50 Hz
  - Fuse protection:  $\leq 3$  A
3. Do not interrupt the mains supply with a time switch or programmer.
4. Connect the product using a fixed connection and an electrical partition with a contact gap of at least 3 mm (e.g. fuses or power switches).
5. Isolation should preferably be by a double pole switched fused spur box having a minimum contact separation of 3 mm on each pole. The fused spur box should be readily accessible and preferably adjacent to the boiler. It should be identified as to its use.

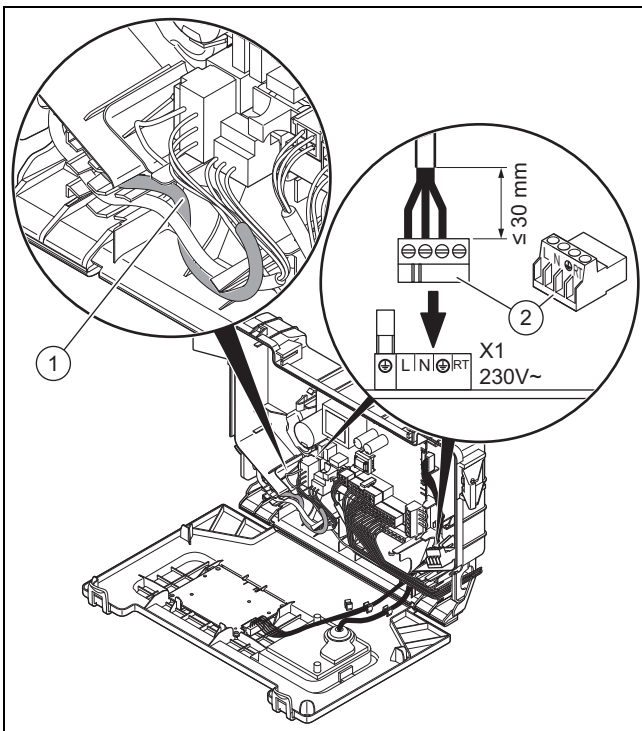

6. Connect the cables.
7. Screw the supplied plug (2) to a three-core power supply cable that complies with the relevant standards.
8. Observe the routing of the power supply cable (1) in the electronics box in order to guarantee that there is no strain.
9. Insert the plug into the bush in the electronics box.
10. Make sure that access to the power supply is always available and is not covered or blocked.

## 7.9.6 Connecting controls to the electronics

1. Ensure that the product is voltage-free.

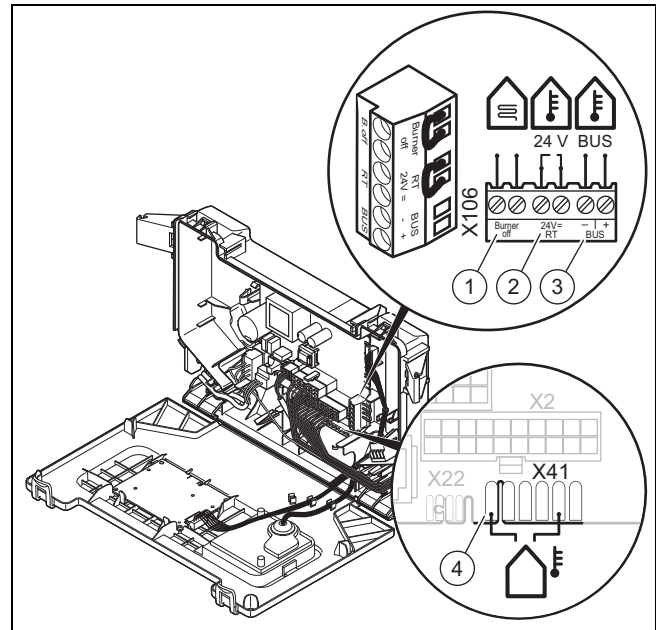

- |   |   |   |                                     |
|---|---|---|-------------------------------------|
| 1 | Limit thermostat for underfloor heating | 3 | eBUS control or radio receiver unit |
| 2 | 24 V control                            | 4 | Outdoor temperature sensor, wired   |
2. Connect the cables.
  3. Connect the individual components depending on the installation type.

**Condition:** If installing a multi-circuit control.

- ▶ Change the pump mode (**d.18**) from Eco (intermittent pump operation) to Comfort (continuous pump operation).

**Condition:** If you are connecting a control (230 V).

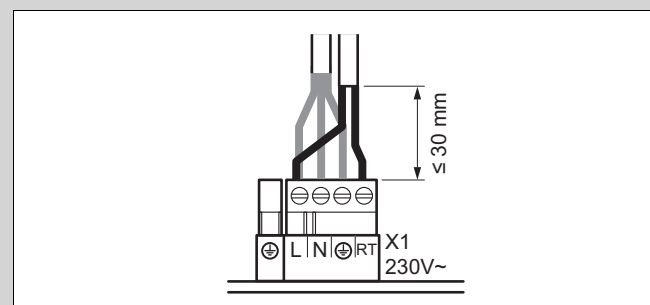

- ▶ Connect the control to the main plug.

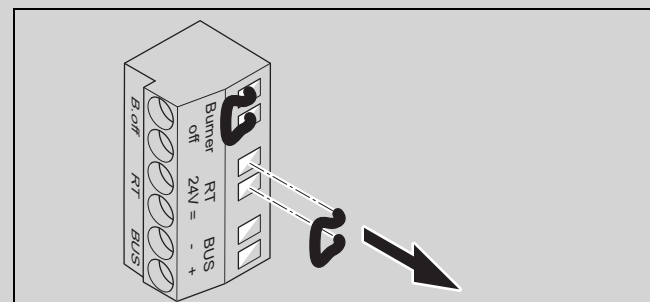

- ▶ Remove the bridge from the 24V=RT plug.

4. Close the electronics box.

# 8 Operation







## 8 Operation

### 8.1 Using diagnostics codes







You can use the parameters marked as adjustable in the table of diagnostics codes to adapt the product to the installation and customer requirements.

Overview of diagnostics codes (→ Page 47)

#### 8.1.1 Activating diagnostics codes

1. Press and hold the  button for seven seconds.
  - ◁  is shown in the display.
2. Press the  or  button to set the value.
  - ◁ The access code **(96)** is reserved for the competent person.
  - ◁ The access code **(35)** is reserved for the customer service.
3. Press the  button to confirm.
  - ◁  is shown in the display.

#### 8.1.2 Setting a diagnostics code

1. Press the  or  button to select the diagnostics code.
2. Press the  button to confirm.
  - ◁ The value and/or status of the diagnostics code is shown in the display.
3. Press the  or  button to set the value.
4. If you allow the value to flash for three seconds, the setting is automatically confirmed.
  - ◁  is shown in the display for 1 second.



#### Note

You can manually confirm the setting at any time by pressing and holding the  button for less than 3 seconds.



5. Proceed accordingly for all parameters that need to be changed.
6. Press and hold the  button for 3 seconds to finish configuring the diagnostics codes.
  - ◁ The display switches to the basic display.

### 8.2 Displaying the status codes

The status codes display the product's current operating mode.

Status codes – Overview (→ Page 50)

#### 8.2.1 Activating the status codes display













1. Hold the  button down for more than 7 seconds.
  - ◁ **S.XX** is shown on the display, followed by the heating flow temperature, the internal system pressure and the cylinder temperature (depending on the version).
2. Press the  button to exit this menu.
  - ◁ The display switches to the basic display.

### 8.3 Using check programmes

By activating various check programmes, you can trigger various special functions on the product.

Check programmes – Overview

#### 8.3.1 Calling up the check programmes



1. Hold the  button down for more than 5 seconds.
  - ◁ All symbols are shown in the display.
  - ◁  is shown in the display.
2. Press and hold the  button for five seconds.
  - ◁  is shown in the display.
3. Press the  or  button to select the check programme.
4. Press the  button to confirm.
  - ◁ **on** is shown in the display and the programme starts.
5. Press the  and  buttons at the same time whilst running a check programme.
  - ◁ The heating water temperature and the filling pressure for the heating installation are shown alternately in the display.
6. Press the  button to return to the check programme.
  - ◁ The display shows the check programme.
7. Press the  button to finish the check programme.
  - ◁ **OFF** is shown in the display.
8. Press and hold the  button for 3 seconds to finish the check programmes.
  - ◁ **End** is shown in the display.
  - ◁ The display switches to the basic display.



#### Note

If you do not press any button for 15 minutes, the current programme is automatically cancelled and the basic display is shown.

#### 8.3.2 Displaying the pressure and temperature of the heating during a check programme

1. Press the  buttons simultaneously.
  - ◁ Display the filling pressure of the heating installation.
  - ◁ Display the heating flow temperature.
2. Press the  button to display the check programme currently running.

## 9 Start-up

### 9.1 Carrying out the initial start-up

Initial start-up must be carried out by a customer service technician or an authorised competent person using the Benchmark Checklist. The Benchmark Checklist (→ Appendix) must be filled in and stored carefully along with the unit's documentation.

- ▶ Carry out the initial start-up using the Benchmark Checklist in the appendix.
- ▶ Fill out and sign the Benchmark Checklist.

### 9.2 Heating water supply in the sealed heating system

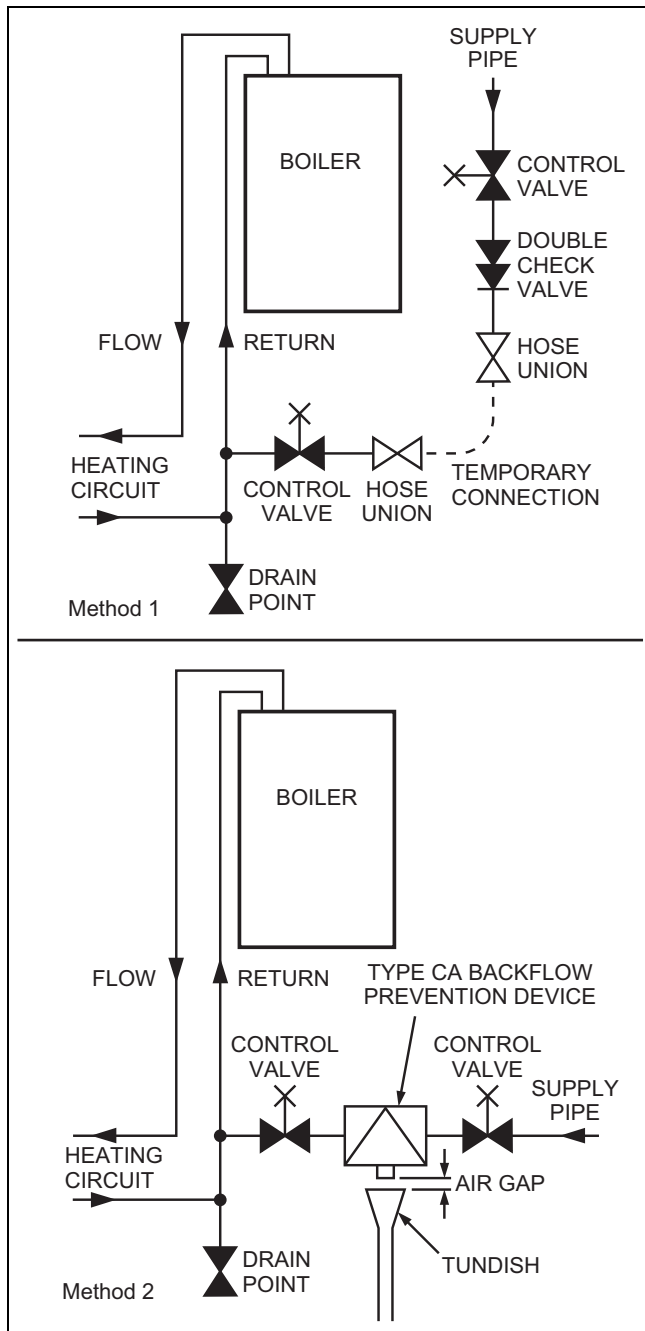

A safety valve must be fitted to a sealed system. It shall be preset, non-adjustable with a lift pressure of 3 bar, incorporating seating of a resilient material, a test device and a connection for drain. The drain from the safety valve must be routed outside the building, must not discharge above an en-

trance or window or any type of public access area, be clear of any electrical fittings and positioned so that any discharge can be seen.

A diaphragm type expansion vessel, conforming to the current issue of BS 4814 (see also BS 7074 Part 1 and 2) must be connected at a point close to the inlet side of the circulating pump, see the diagrammatic layout, above unless laid down differently by the manufacturer. The expansion vessel volume depends on the total water system volume and the initial system design pressure. For any system an accurate calculation of vessel size is given in the current issue of BS 5449 and BS 7074 Part 1. Example: For an initial design pressure of 0.7 bar, the minimum total vessel volume required is  $0.063 \times \text{Total System Volume}$ .



#### Note

A higher initial design pressure requires a larger volume expansion vessel.

In GB, guidance on vessel sizing is also given in the current issue of BS 5449 and BS 7074 Part 1. In IE refer to the current edition of I.S. 813 "Domestic Gas Installations". The charge pressure must not be less than the static head of the system, that is, the height of the highest point of the system above the expansion vessel.

A pressure gauge with a set pointer and covering at least 0 to 4 bar (0 to 60 lb/in<sup>2</sup>) shall be fitted permanently to the system in a position where it can be seen when filling the system.

### 9.3 Checking and treating the heating water/filling and supplementary water



#### Caution.

#### Risk of material damage due to poor-quality heating water

- ▶ Ensure that the heating water is of sufficient quality.

- ▶ Before filling or topping up the installation, check the quality of the heating water.

#### Checking the quality of the heating water

- ▶ Remove a little water from the heating circuit.
- ▶ Check the appearance of the heating water.
- ▶ If you ascertain that it contains sedimentary materials, you must desludge the installation.
- ▶ Use a magnetic rod to check whether it contains magnetite (iron oxide).
- ▶ If you ascertain that it contains magnetite, clean the installation and apply suitable corrosion-inhibition measures, or fit a magnetic filter.
- ▶ Check the pH value of the removed water at 25 °C.
- ▶ If the value is below 6.5 or above 8.5, clean the installation and treat the heating water.
- ▶ Ensure that oxygen cannot get into the heating water.

#### Checking the filling and supplementary water

- ▶ Before filling the installation, measure the hardness of the filling and supplementary water.

## 9 Start-up

### Treating the filling and supplementary water

- ▶ Observe all applicable national regulations and technical rules when treating the filling and supplementary water.

Provided the national regulations and technical rules do not stipulate more stringent requirements, the following applies:

You must treat the heating water in the following cases

- If the entire filling and supplementary water quantity during the operating life of the system exceeds three times the nominal volume of the heating installation, or
- If the guideline values listed in the following table are not met, or
- If the pH value of the heating water is less than 6.5 or more than 8.5.

Total heating output	Water hardness at specific system volume <sup>1)</sup>					
	≤ 20 l/kW		> 20 l/kW ≤ 50 l/kW		> 50 l/kW	
kW	ppm CaCO <sub>3</sub>	mol/m <sup>3</sup>	ppm CaCO <sub>3</sub>	mol/m <sup>3</sup>	ppm CaCO <sub>3</sub>	mol/m <sup>3</sup>
< 50	< 300	< 3	200	2	2	0.02
> 50 to ≤ 200	200	2	150	1.5	2	0.02
> 200 to ≤ 600	150	1.5	2	0.02	2	0.02
> 600	2	0.02	2	0.02	2	0.02

1) Nominal capacity in litres/heating output; in the case of multi-boiler systems, the smallest single heating output is to be used.



#### Caution.

**The use of unsuitable heating water may cause aluminium corrosion and a resulting lack of leak-tightness.**

In contrast to steel, grey cast iron or copper, for example, aluminium reacts with alkaline heating water (pH value > 8.5) to produce substantial corrosion.

- ▶ When using aluminium, make sure that the pH value of the heating water is between 6.5 and a maximum of 8.5.



#### Caution.

**Risk of material damage if the heating water is treated with unsuitable additives.**

Unsuitable additives may cause changes in the components, noises in heating mode and possibly subsequent damage.

- ▶ Do not use any unsuitable antifreeze and corrosion inhibitors, biocides or sealants.

No incompatibility with our products has been detected to date with proper use of the following additives.

- ▶ When using additives, follow the manufacturer's instructions without exception.

We accept no liability for the compatibility of any additive or its effectiveness in the rest of the heating system.

### Additives for cleaning measures (subsequent flushing required)

- Adey MC3+
- Adey MC5
- Fernox F3
- Sentinel X 300
- Sentinel X 400

### Additives intended to remain permanently in the installation

- Adey MC1+
- Fernox F1
- Fernox F2
- Sentinel X 100
- Sentinel X 200

### Additives for frost protection intended to remain permanently in the installation

- Adey MC ZERO
- Fernox Antifreeze Alphi 11
- Sentinel X 500

- ▶ If you have used the above-mentioned additives, inform the end user about the measures that are required.
- ▶ Inform the end user about the measures required for frost protection.

## 9.4 Filling the condensate siphon

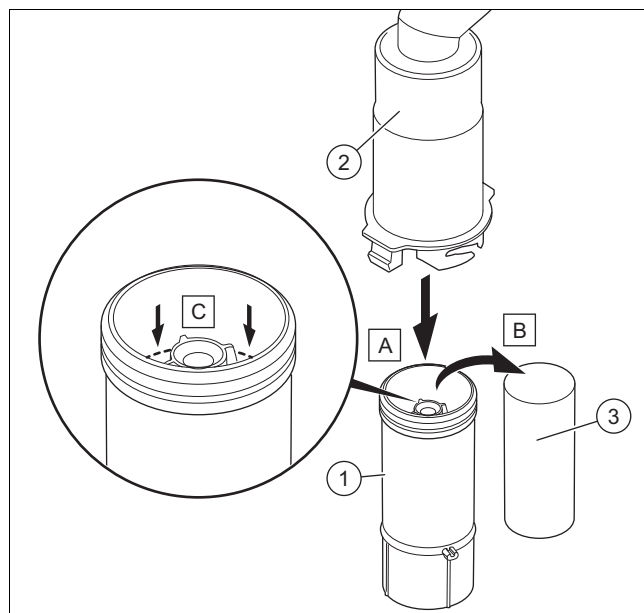

1. Unclip the lower section of the siphon (1) from the upper section of the siphon (2).
2. Remove the float (3).
3. Fill the lower section of the siphon with water up to 10 mm below the upper edge of the condensate discharge pipe.
4. Re-insert the float (3).



#### Note

Check that the float is present in the condensate siphon.

5. Clip the lower section of the siphon (1) into the upper section of the siphon (2).

### 9.5 Checking the gas type

Make sure that the product is set up correctly by checking the gas type. This ensures optimum combustion quality.

- ▶ Check the gas type as part of routine product maintenance work when replacing components or carrying out work on the gas route.

### 9.6 Checking the factory setting

The product's combustion has been factory tested and is preset for operation with the gas group indicated on the data plate.

The product is only authorised to be operated with natural gas.

- ▶ Check the information about the gas type indicated on the data plate and compare this with the gas type available at the installation site.

**Condition:** The product design is **not compatible** with the local gas group

- ▶ Do not start up the product.

**Condition:** The product design is **compatible** with the local gas group

- ▶ Proceed as described below.

### 9.7 Avoiding danger arising from insufficient water pressure

The filling pressure must be between 0.10 and 0.15 MPa (1.0 and 1.5 bar).



**Note**

If the heating flow temperature is shown in the display, press and hold the  $\ominus$  and  $\oplus$  buttons at the same time for longer than five seconds, or temporarily deactivate heating mode in order to display the pressure.

If the heating installation extends over several storeys, higher filling pressures may be required to avoid air entering the heating installation.

If the water pressure falls below 0.05 MPa (0.5 bar), the value flashes in the display.

If the water pressure falls below 0.03 MPa (0.3 bar), the product switches off. The display shows 0.0 MPa (0.0 bar). Fault F22 will be stored in the fault list.

- ▶ Top up the water in the heating installation to start up the product again.
  - ◁ The pressure value flashes in the display until a pressure of 0.05 MPa (0.5 bar) or higher has been reached.

### 9.8 Switching on the product

- ▶ Switch on the product via the main switch installed on-site.

### 9.9 Filling and purging the heating installation

#### Preliminary work

- ▶ Flush the heating installation through.

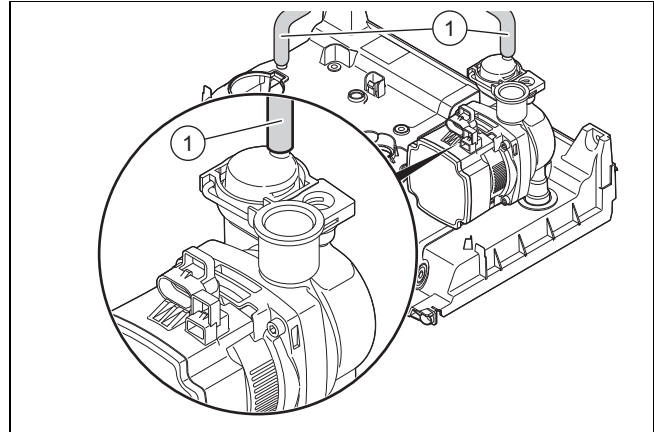

1. Check the silicone hose connection (1) between the pump's automatic air vent and the hydraulic console.
2. Fill with water until the required filling pressure is reached.
  - Recommended filling pressure: 1 to 1.5 bar
  - ◁ The heating and hot water functions cannot be activated.
  - ◁ The pressure value flashes in the display until a pressure of 0.05 MPa (0.5 bar) or higher has been reached.
  - ◁ An automatic air vent function is activated if the pressure exceeds 0.05 MPa (0.5 bar) for longer than 15 seconds.
3. Purge each radiator until the water escapes normally, and then retighten the system's purging valves.
4. Check whether all connections are leak-tight.

**Condition:** If the noise persists in the boiler

- ▶ Purge the product again by activating check programme (P.07) and then (P.06).  
Check programmes – Overview

### 9.10 Filling the domestic hot water circuit

1. Open the water tap to fill the domestic hot water circuit.
2. Close the water tap once the appropriate volume of water has flowed out.
  - ◁ The domestic hot water circuit is filled.
3. Check all connections and the entire system for leak-tightness.

## 9 Start-up

### 9.11 Checking the gas setting

Only a qualified competent person is authorised to implement the settings on the gas valve assembly.

Each destroyed seal must be replaced.

The CO<sub>2</sub> adjusting screw must be sealed.

Never modify the factory setting of the gas pressure regulator of the gas valve assembly.

#### 9.11.1 Checking the gas flow rate

The gas flow rate has been set during production and does not require adjustment. With the front casing fitted check the gas flow rate of the boiler as follows:

- ▶ Start up the product with the check programme **P.01**.
- ▶ In addition, ensure that maximum heat can be dissipated into the heating system by turning up the room thermostat.
- ▶ Wait at least 5 minutes until the boiler has reached its operating temperature.
- ▶ Ensure that all other gas appliances in the property are turned off.
- ▶ Measure the gas flow rate at the gas meter.
- ▶ Compare the measured values with the corresponding values in the table.

Q <sub>nw</sub> from the data plate	H gas in m <sup>3</sup> /h		
	Nom.	+5%	-10%
15.3	1.62	1.70	1.46
18.4	1.95	2.05	1.76
24.7	2.61	2.74	2.35
25.7	2.72	2.86	2.45
28.6	3.03	3.18	2.73
30.6	3.24	3.40	2.92
35.7	3.78	3.97	3.40

**Condition:** Gas flow rate not in the permissible range

- ▶ Check all of the piping and ensure that the gas flow rates are correct.
- ▶ Only put the product into operation once the gas flow rates have been corrected.

**Condition:** Gas flow rate in the permissible range

- ▶ End the check programme **P.01**.
- ▶ Allow the boiler to cool down by allowing pump overrun to operate for a minimum of 2 minutes.
- ▶ Record the boiler maximum gas flow rate onto the Benchmark gas boiler commissioning checklist.

### 9.11.2 Checking the gas connection pressure (gas flow pressure)

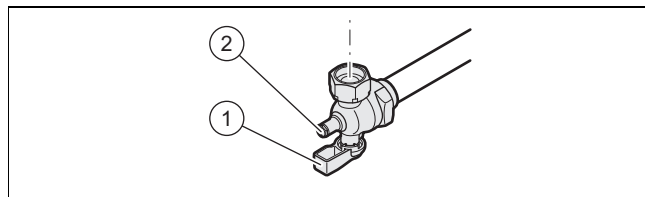

1. Ensure that the gas inlet working pressure can be obtained with all other gas appliances in the property working.
2. Close the gas stopcock **(1)**.
3. Undo the sealing screw on the test nipple **(2)**.
4. Connect a manometer to the test nipple **(2)**.
5. Open the gas stopcock **(1)**.
6. Start up the product with check programme **P.01** (installation with eBUS control).
7. In addition, ensure that maximum heat can be dissipated by fully opening one or more hot water taps.
8. With the boiler operating at full load check that the gas inlet working pressure at the reference test point **(2)** complies with the requirements.

#### Permissible gas flow pressure for operation with

Natural gas H	1.3 to 2.3 kPa (13.0 to 23.0 mbar)
---------------	---------------------------------------

9. Should the pressure recorded at the reference test point in the boiler be lower than indicated check if there is any blockage in the pipework or if the pipework is undersized.

**Condition:** Gas flow pressure not in the permissible range



#### Caution.

#### Risk of material damage and operating faults caused by incorrect gas connection pressure.

If the gas connection pressure lies outside the permissible range, this can cause operating faults in and damage to the product.

- ▶ Do not make any adjustments to the product.
- ▶ Do not start up the product.

- ▶ If you cannot correct the failure, notify the gas supply company and proceed as follows:
- ▶ End check programme P.01.
- ▶ Allow the boiler to cool down by allowing pump overrun to operate for a minimum of two minutes.
- ▶ Close the gas stopcock.
- ▶ Remove the pressure gauge and retighten the sealing screw **(2)** for the measuring nipple.
- ▶ Open the gas stopcock **(1)**.
- ▶ Check the test nipple for gas tightness.
- ▶ Close the gas stopcock **(1)**.
- ▶ Install the front casing. (→ Page 21)
- ▶ Disconnect the product from the electrical installation.
- ▶ You must not start up the boiler.

**Condition:** Gas flow pressure in the permissible range

- ▶ End the check programme **P.01**.
- ▶ Allow the boiler to cool down allowing pump overrun to operate for a minimum of two minutes.
- ▶ Close the gas stopcock **(1)**.
- ▶ Remove the pressure gauge and retighten the sealing screw **(2)** for the measuring nipple.
- ▶ Open the gas stopcock **(1)**.
- ▶ Check the test nipple for gas tightness.
- ▶ Install the front casing. (→ Page 21)
- ▶ Reset boiler controls for normal operation.
- ▶ Record the appliance gas inlet working pressure (kPa resp. mbar) in the Benchmark gas boiler commissioning checklist.

### 9.11.3 Checking the air/flue pipe/flue gas recirculation

1. Check the flue gas installation is intact in accordance with the latest gas safe technical bulletin and information supplied in the installation instructions.
2. For extended flue gas installations check for flue gas recirculation using the air analysis point.
3. Use a flue gas analyser.
4. If you discover unusual levels of CO or CO<sub>2</sub> in the supply air, search for the leak in the flue system or for signs of flue gas recirculation.
5. Eliminate the damage properly.
6. Check again whether the supply air contains any unusual levels of CO or CO<sub>2</sub>.
7. If you cannot eliminate the damage, do not start up the product.

### 9.11.4 Checking the CO<sub>2</sub> content

1. Start up the product with the check programme **(P.01)** and set the value.
  - Setting value for the programme P.01: 100
 Check programmes – Overview
2. Wait until the value that is read is stable.
  - Waiting period for reading a stable value: 5 min

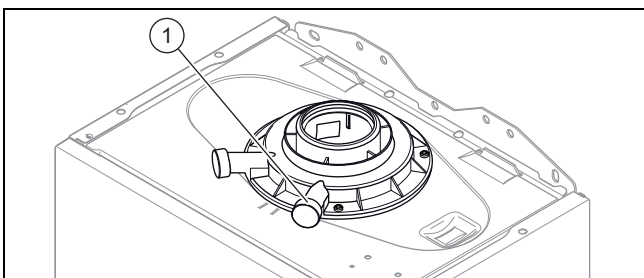

3. Unscrew the cover from the flue gas analysis point **(1)**.
4. Measure the CO<sub>2</sub> content at the flue gas analysis point **(1)**.
5. Compare the measured value with the corresponding value in the table.

<b>Great Britain and Ireland</b>
<b>Removed front casing / installed front casing</b>
<b>Natural gas</b>
<b>H</b>
9.2 ±1%

- ◁ The value is OK.
- ▽ The value is not OK; you cannot start up the product.
  - ▶ Inform Customer Service.

### 9.12 Thoroughly flushing the heating installation ("hot")

1. Operate the appliance until the boiler and the heating system are up to temperature.
2. Check the heating system for leaks.
3. Connect a hose to the drain valve located at the lowest position of the heating system.
4. Shut off the boiler, open the drain valve and all purge valves on the radiators and allow the water to flow out of the heating system and the boiler quickly and fully.
5. Close the drain valve.
6. Fill the heating system again with water as described in Filling the heating installation and Purging the heating installation.
7. Re-fill the system until the system design pressure of 0,1 MPa (1,0 bar) is attained.



#### Note

The actual reading on the digital pressure gauge should ideally be 0,05 MPa (0,5 bar) plus an additional pressure corresponding to the highest point of the system above the base of the boiler – 10 m head equals an additional 1 bar reading on the pressure gauge. The minimum pressure should not be less than 0,1 MPa (1 bar) in any installation. If the system is to be treated with an inhibitor it should be applied at this stage in accordance with the manufacturer's instructions

8. Install the front casing.

### 9.13 Checking leak-tightness

- ▶ Check the gas pipe, the heating circuit and the hot water circuit for leak-tightness.
- ▶ Check that the air/flue pipe has been installed correctly.

**Condition:** Room-sealed operation

- ▶ Check whether the vacuum chamber has been closed tightly.

#### 9.13.1 Checking the heating mode

1. Activate the heating mode on the user interface.
2. Turn all thermostatic valves on the radiators until they are fully open.
3. Allow the product to operate for at least 15 minutes.
4. Fill and purge the heating installation. (→ Page 31)

## 9 Start-up

5. Activate the display for the current operating mode.  
(→ Page 28)  
Status codes – Overview (→ Page 50)  
◀ If the product is working correctly, the display shows **S.04.**

### 9.13.2 Checking the domestic hot water generation

1. Activate the domestic hot water mode on the user interface.
2. Open a hot water tap completely.
3. Activate the display for the current operating mode.  
(→ Page 28)  
Status codes – Overview (→ Page 50)  
◀ If the product is working correctly, the display shows **S.14.**

## 10 Adapting the unit to the installation

You can reset/change the system parameters (section "Using diagnostics codes").

Overview of diagnostics codes (→ Page 47)

### 10.1 Setting the burner anti-cycling time

To prevent frequent switching on and off of the burner and thus prevent energy losses, an electronic restart lockout is activated for a specific period each time the burner is switched off. The burner anti-cycling time is only active for the heating mode. Domestic hot water mode during a burner anti-cycling time does not affect the timing element.

#### 10.1.1 Setting the maximum burner anti-cycling time

1. Set diagnostics code . (→ Page 28)  
Overview of diagnostics codes (→ Page 47)
2. If required, change the maximum burner anti-cycling time using the diagnostics code **d.02**.

#### 10.1.2 Resetting the remaining burner anti-cycling time

- ▶ Hold the  $\odot$  button down for more than 3 seconds.  
◀  $\dagger$  is shown in the display.

### 10.2 Setting the pump output

The product is equipped with a speed-regulated high-efficiency pump, which adjusts independently to the hydraulic conditions of the heating installation.

If you have installed a low loss header in the heating installation, you should switch off the speed regulation and set the pump output to a fixed value.

- ▶ If required, change the setting of the pump speed, which depends on the operating mode, under diagnostics code **d.14**.
- ▶ Set diagnostics code . (→ Page 28)  
Overview of diagnostics codes (→ Page 47)

#### Flow rate-pressure curves for 25 kW (pressure measured downstream of the valves)

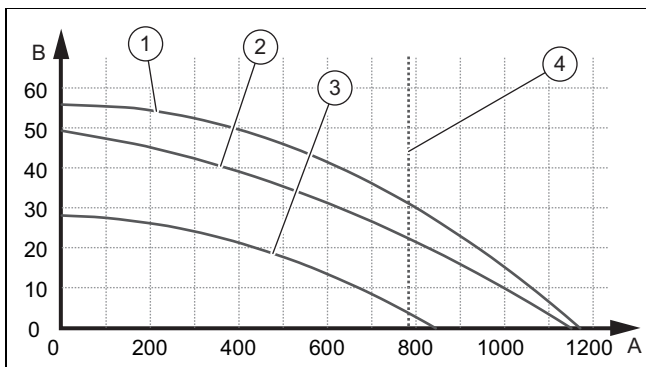

- |   |  |   |  |
|---|--|---|--|
| 1 | Maximum speed (bypass closed)                  | 4 | Flow rate at maximum output ( $\Delta T = 20K$ ) |
| 2 | Maximum speed (factory setting for the bypass) | A | Flow rate in circuit (l/h)                       |
| 3 | Minimum speed (factory setting for the bypass) | B | Available pressure (kPa)                         |

#### Flow rate-pressure curves for 30 kW (pressure measured downstream of the valves)

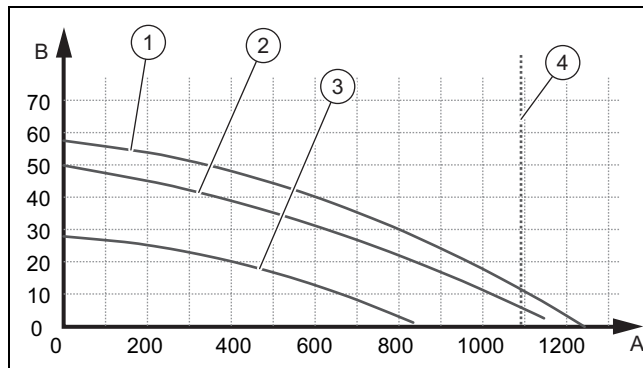

- |   |  |   |  |
|---|--|---|--|
| 1 | Maximum speed (bypass closed)                  | 4 | Flow rate at maximum output ( $\Delta T = 20K$ ) |
| 2 | Maximum speed (factory setting for the bypass) | A | Flow rate in circuit (l/h)                       |
| 3 | Minimum speed (factory setting for the bypass) | B | Available pressure (kPa)                         |

#### Flow rate-pressure curves for 35 kW (pressure measured downstream of the valves)

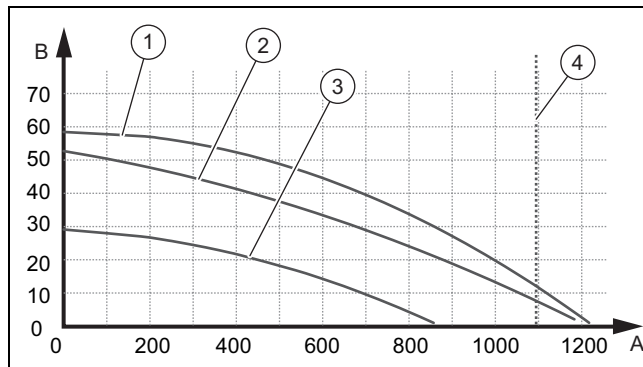

- |   |  |   |  |
|---|--|---|--|
| 1 | Maximum speed (bypass closed)                  | 4 | Flow rate at maximum output ( $\Delta T = 20K$ ) |
| 2 | Maximum speed (factory setting for the bypass) | A | Flow rate in circuit (l/h)                       |
| 3 | Minimum speed (factory setting for the bypass) | B | Available pressure (kPa)                         |

### 10.3 Setting the bypass valve



#### Caution.

#### Risk of material damage caused by incorrect setting of the high-efficiency pump

If the pressure at the bypass valve is increased (by turning it clockwise) and the pump output is set to less than 100%, the product may not operate correctly.

- ▶ In this case, set the pump output to 5 = 100% using diagnostics parameter **d.14**.

# 11 Handing over to the end user

Condition: d.14 is set to 0 = auto

- ▶ Do not change the factory settings.

Condition: d.14 is set to 1 - 5

- ▶ Remove the front casing.

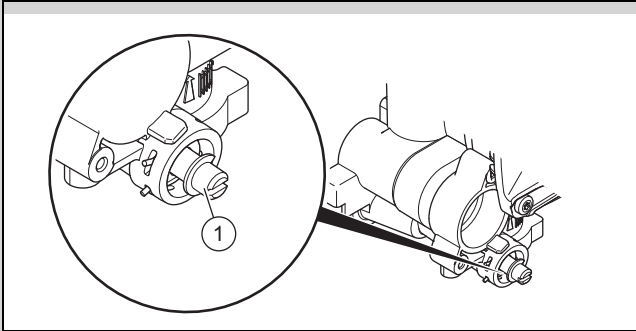

- ▶ Regulate the pressure using the adjusting screw (1).

Position of the adjusting screw	Notes/application
Right-hand stop (screwed all the way in)	If the radiators do not heat up sufficiently at the factory setting. In this case, you must set the pump to the maximum speed.
Mid-position (six anti-clockwise rotations)	Factory setting
Five further anti-clockwise rotations starting from the mid-position	If noises are produced in the radiators or radiator valves.

- ▶ Install the front casing. (→ Page 21)

- ▶ When you have finished the installation, affix the enclosed sticker (which requests that the user reads the instructions) to the front of the product in the end user's language.
- ▶ Draw attention, to the current issue of the Gas Safety (Installation and Use) Regulations, Section 35, which imposes a duty of care on all persons who let out any property containing a gas appliance in the UK.
- ▶ Explain to the end user how the safety devices work and where they are located.
- ▶ Inform the end user how to handle the product.
- ▶ In particular, draw attention to the safety warnings that the end user must follow.
- ▶ Inform the end user that they must have the product maintained in accordance with the specified intervals.
- ▶ Pass all of the instructions and documentation for the product to the end user for safe-keeping.
- ▶ Inform the end user about measures taken to ensure the supply of combustion air and flue gas guiding, and instruct the operator that he must not make any changes.
- ▶ Inform the end user that they must not store or use explosive or highly flammable substances (such as petrol, paper or paint) in the installation room of the product.
- ▶ Complete and sign off the Benchmark commissioning check list.
- ▶ Complete and sign off the guarantee documentation.

## 10.4 Setting the domestic hot water temperature

1. Observe the applicable regulations regarding legionella prevention.



### Danger!

#### Risk of death from legionella.

Legionella multiply at temperatures below 60 °C.

- ▶ Ensure that the end user is familiar with all of the Anti-legionella measures in order to comply with the applicable regulations regarding legionella prevention.

2. Set the domestic hot water temperature.

Condition: Water hardness: > 3.57 mol/m<sup>3</sup>

- Domestic hot water temperature: ≤ 50 °C

3. Descale the water as required.

## 11 Handing over to the end user

- ▶ At the time of commissioning complete all relevant sections of the Benchmark commissioning checklist, located at the rear of this document.
- ▶ For IE: Complete a "Declaration of Conformity" to indicate compliance to I.S. 813. An example of this is given in the current edition of I.S. 813.

## 12 Inspection and maintenance

### 12.1 Using original seals

If you replace components, use only the enclosed original seals; additional sealing materials are not required.

### 12.2 Observing inspection and maintenance intervals

- ▶ Adhere to the minimum inspection and maintenance intervals. The inspection may require maintenance to be carried out earlier, depending on the results.  
Inspection and maintenance work – Overview

### 12.3 Procuring spare parts

The original components of the product were also certified by the manufacturer as part of the declaration of conformity. If you use other, non-certified or unauthorised parts during maintenance or repair work, this may void the conformity of the product and it will therefore no longer comply with the applicable standards.

We strongly recommend that you use original spare parts from the manufacturer as this guarantees fault-free and safe operation of the product. To receive information about the available original spare parts, contact the contact address provided on the back page of these instructions.

- ▶ If you require spare parts for maintenance or repair work, use only the spare parts that are permitted for the product.

### 12.4 Checking the CO<sub>2</sub> content

1. Start up the product with the check programme (P.01) and set the value.
  - Setting value for the programme P.01: 100
 Check programmes – Overview
2. Wait until the value that is read is stable.
  - Waiting period for reading a stable value: 5 min

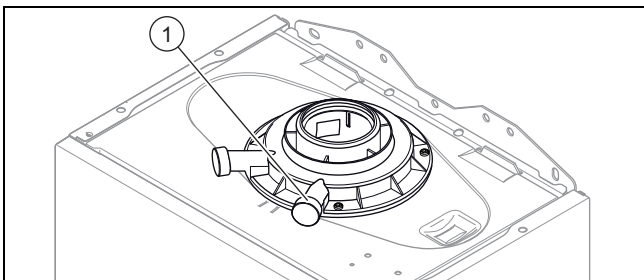

3. Unscrew the cover from the flue gas analysis point (1).
4. Measure the CO<sub>2</sub> content at the flue gas analysis point (1).
5. Compare the measured value with the corresponding value in the table.

<b>Great Britain and Ireland</b>
<b>Removed front casing / installed front casing</b>
<b>Natural gas</b>
<b>H</b>
9.2 ±1%

◁ The value is OK.

- ▽ The value is not OK; you cannot start up the product.
  - ▶ Set the CO<sub>2</sub> content.

### 12.5 Removing the gas-air mixture unit



#### Note

The gas-air mixture unit consists of three main components:

- Fan
- Gas valve assembly
- Burner hood

1. Switch off the product via the main switch.
2. Close the gas stopcock.
3. Remove the front casing.

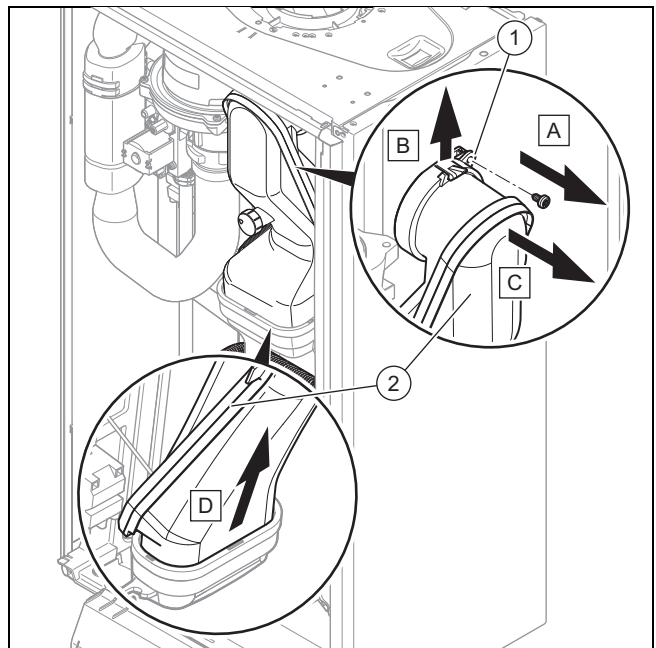

4. Remove the screw (1).
5. Push the clip upwards.
6. Remove the flue pipe (2).

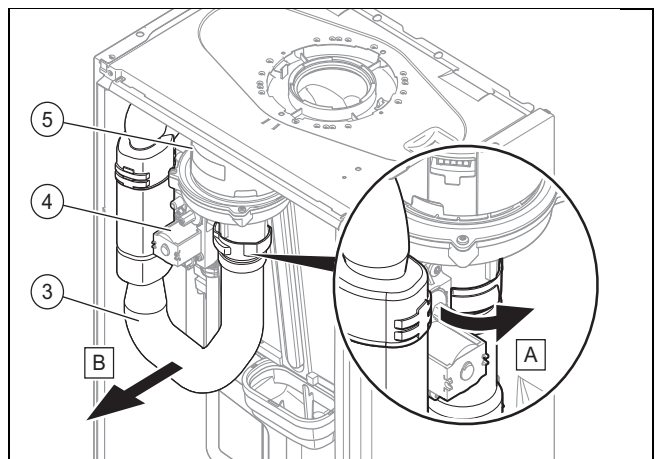

7. Remove the air intake pipe (3).
8. Remove the plugs from the gas valve assembly (4) and from the fan (5).

## 12 Inspection and maintenance

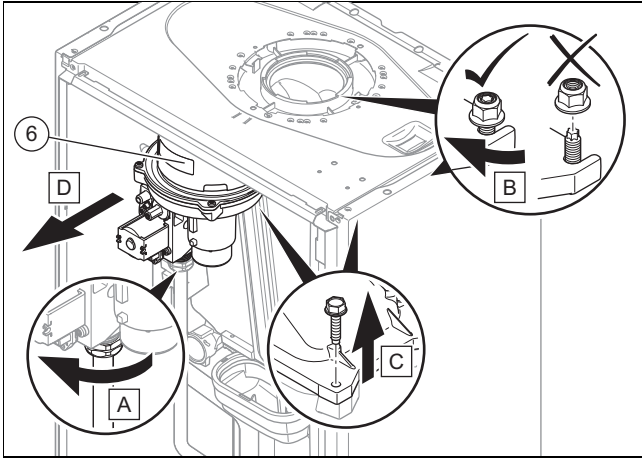

- Remove the gas-air mixture unit (6).

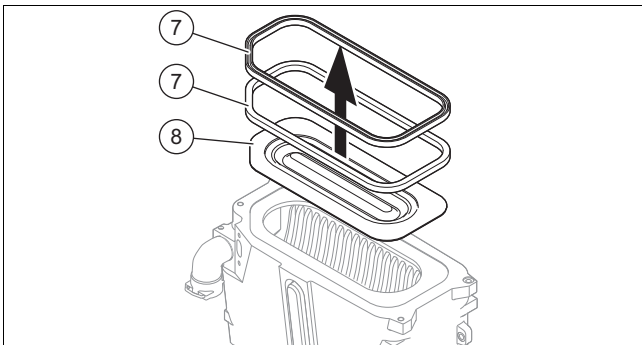

- Remove the burner seals (7) and the burner (8).
- Check the burner and the heat exchanger for damage and dirt.
- If necessary, clean or replace the components according to the following sections.
- Install the two new burner seals.

### 12.6 Cleaning the heat exchanger

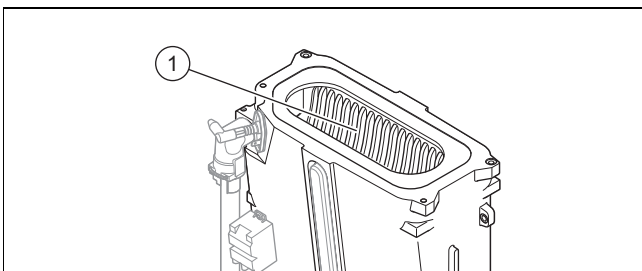

- Protect the open electronics box from spraying water.
- Clean the ribs of the heat exchanger (1) with water.
  - ◀ The water runs out into the condensate tray.

### 12.7 Checking the burner

- Check the surface of the burner for possible damage. If you see any damage, replace the burner.
- Install the two new burner seals.

### 12.8 Checking the ignition electrode

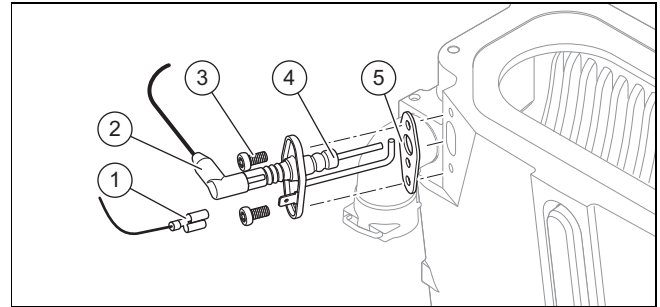

- Disconnect the connection (2) and the earth cable (1).
- Remove the fixing screws (3).
- Carefully remove the electrode from the combustion chamber.
- Check that the electrode ends (4) are undamaged.
- Check the electrode distance.
  - Clearance for the ignition electrodes: 3.5 to 4.5 mm
- Make sure that the seal (5) is free from damage.
  - ▽ If necessary, replace the seal.

### 12.9 Cleaning the condensate siphon

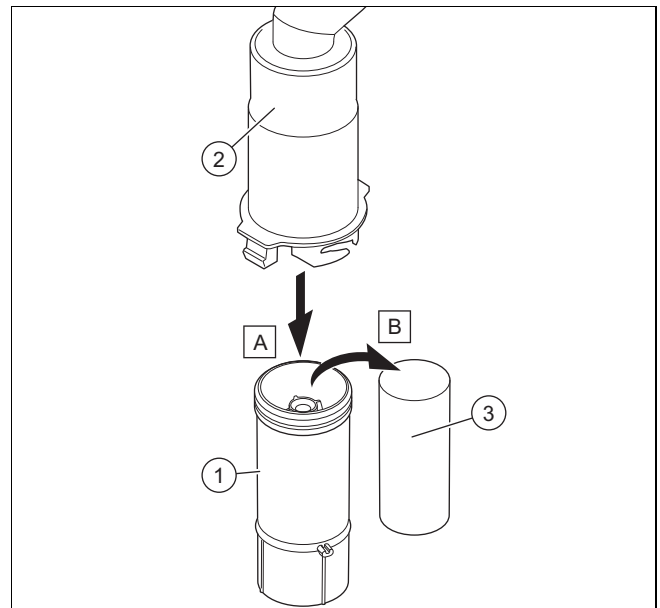

- Unclip the lower section of the siphon (1) from the upper section of the siphon (2).
- Remove the float (3).
- Flush out the lower section of the siphon with water.
- Re-insert the float (3).



#### Note

Check whether the float is present in the condensate siphon.

- Clip the lower section of the siphon (1) into the upper section of the siphon (2).

## 12.10 Cleaning the strainer in the cold water inlet

1. Close the main cold water supply line.
2. Drain the product on the domestic hot water side.
3. Remove the connector from the connection for the product's cold water pipe.
4. Clean the strainer in the cold water inlet without removing it.

## 12.11 Cleaning the heating filter

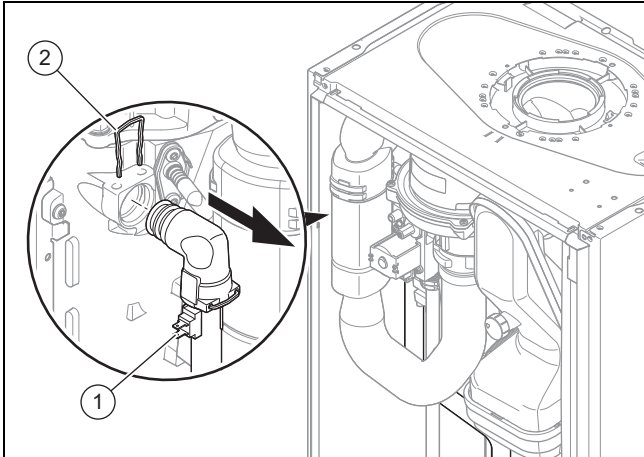

1. Remove the temperature sensor (1).
2. Remove the upper clip (2).

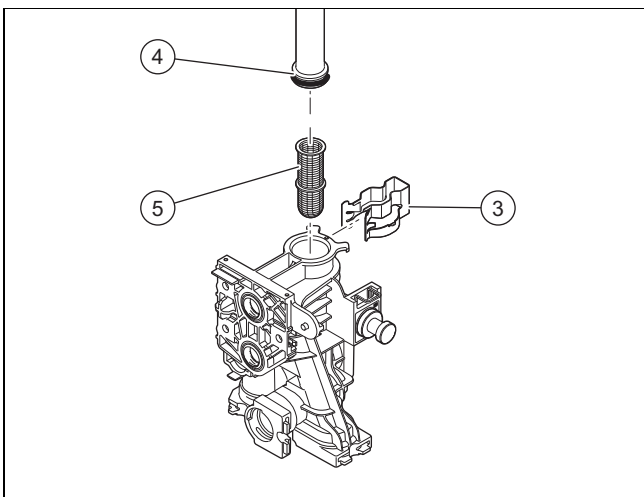

3. Remove the lower clip (3).
4. Remove the flow pipe (4).
5. Remove the heating filter (5) and clean it.
6. Reinstall the components in the reverse order.

## 12.12 Installing the gas-air mixture unit

1. Install the burner.
2. Install two new burner seals in the burner hood.
3. Install the gas-air mixture unit.
4. Tighten the screws on the gas-air mixture unit.
  - Ideally to 7 Nm if a torque spanner is available.
5. Install the flue pipe.
6. Install the air intake pipe.

## 12.13 Draining the product

1. Close the service valves of the product.
2. Start check programme P.05 (→ Page 28).  
Check programmes – Overview
3. Open the draining cock.

## 12.14 Checking the pre-charge pressure of the expansion vessel

1. Measure the pre-charge pressure of the expansion vessel at the vessel valve.

**Condition:** Pre-charge pressure < 0.075 MPa (0.75 bar)

► Top up the expansion vessel in accordance with the static height of the heating installation, ideally with nitrogen, otherwise with air. Ensure that the drain valve is open when topping up.

2. If water escapes from the valve of the expansion vessel, you must replace the expansion vessel (→ Page 41).
3. Fill and purge the heating installation. (→ Page 31)

## 12.15 Completing inspection and maintenance work

1. Start a test operation after the maintenance.
2. Check the heating mode and, if required, the domestic hot water generation (if available).
3. Check the gas type. (→ Page 31)
4. Check the gas connection pressure (gas flow pressure). (→ Page 32)
5. Check the CO<sub>2</sub> content. (→ Page 33)
6. Install the front casing.
7. Fill out the relevant Service Record section in the Benchmark Checklist.

## 12.16 Checking the product for leak-tightness

- Check that the product is leak-tight. (→ Page 33)

# 13 Troubleshooting

## 13 Troubleshooting

### 13.1 Eliminating faults



- ▶ If fault codes (F.XX) appear, consult the table in the appendix or use the check programme(s).  
Overview of fault codes (→ Page 51)  
Check programmes – Overview

If several fault codes are generated at the same time, these are displayed alternately followed by the time at which the respective fault occurred.

- ▶ Hold the  button down for more than 3 seconds.
- ▶ If you are unable to clear the fault code and it reappears despite several reset attempts, contact customer service.

### 13.2 Calling up the fault memory

The last 10 fault codes are stored in the fault memory (together with the time at which the respective fault occurred and, after 24 hours, with the number of days).

- ▶ Hold the  button down for more than 7 seconds.  
Overview of fault codes (→ Page 51)
- ▶ Press the  button to exit this menu.

### 13.3 Deleting the fault memory

1. Delete the fault memory using the diagnostics code **d.94**.
2. Set diagnostics code . (→ Page 28)  
Overview of diagnostics codes (→ Page 47)

### 13.4 Resetting parameters to factory settings

1. Reset all parameters to the factory settings using the diagnostics code **d.96**.
2. Set diagnostics code . (→ Page 28)  
Overview of diagnostics codes (→ Page 47)

### 13.5 Preparing the repair work

1. Switch off the product.
2. Disconnect the product from the electrical installation.
3. Remove the front casing.
4. Close the gas stopcock.
5. Close the service valves in the heating flow and in the heating return.
6. Close the service valve in the cold water pipe.
7. Drain the product if you want to replace water-bearing components of the product.
8. Ensure that water does not drip on live components (e.g. the electronics box).
9. Use only new seals and O-rings. Do not use any additional sealing materials.

#### 13.5.1 Procuring spare parts

The original components of the product were also certified by the manufacturer as part of the declaration of conformity. If you use other, non-certified or unauthorised parts during maintenance or repair work, this may void the conformity of the product and it will therefore no longer comply with the applicable standards.

We strongly recommend that you use original spare parts from the manufacturer as this guarantees fault-free and safe

operation of the product. To receive information about the available original spare parts, contact the contact address provided on the back page of these instructions.

- ▶ If you require spare parts for maintenance or repair work, use only the spare parts that are permitted for the product.

### 13.6 Replacing defective components

#### 13.6.1 Replacing the burner

1. Remove the gas-air mixture unit. (→ Page 37)
2. Remove the two burner seals.
3. Remove the burner .
4. Insert the new burner.
5. Insert two new burner seals in the burner hood.
6. Install the gas-air mixture unit. (→ Page 39)

#### 13.6.2 Replacing the gas-air mixture unit

1. Remove the gas-air mixture unit. (→ Page 37)
2. Install the new gas-air mixture (→ Page 39).

#### 13.6.3 Replacing the heat exchanger

1. Remove the front casing.
2. Remove the gas-air mixture unit. (→ Page 37)

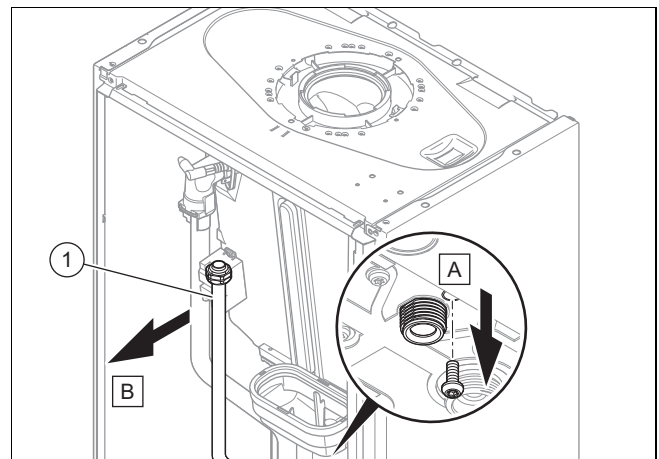

3. Remove the gas pipe (1).

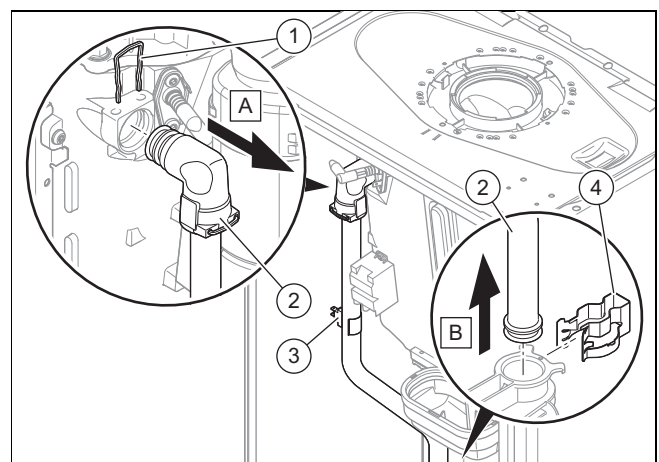

4. Remove the temperature sensor (3).
5. Remove the upper clip (1).
6. Remove the lower clip (4).
7. Remove the flow pipe (2).

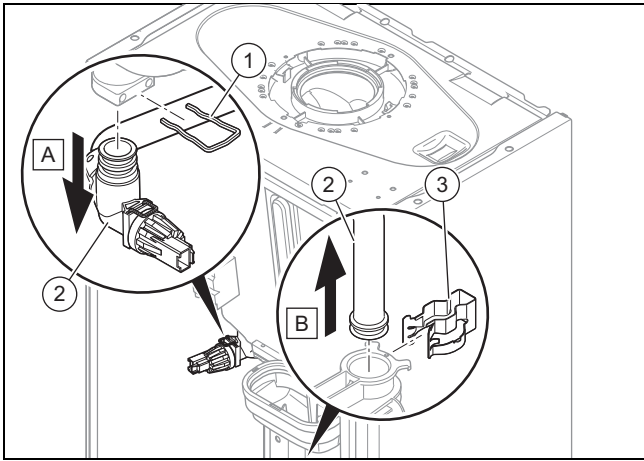

8. Remove the upper clip (1).
9. Remove the lower clip (3).
10. Remove the return pipe (2).

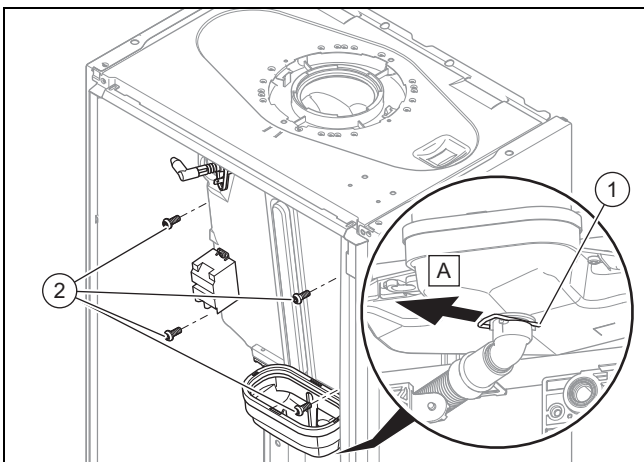

11. Remove the clip underneath the condensate tray (1).
12. Undo the four screws (2).

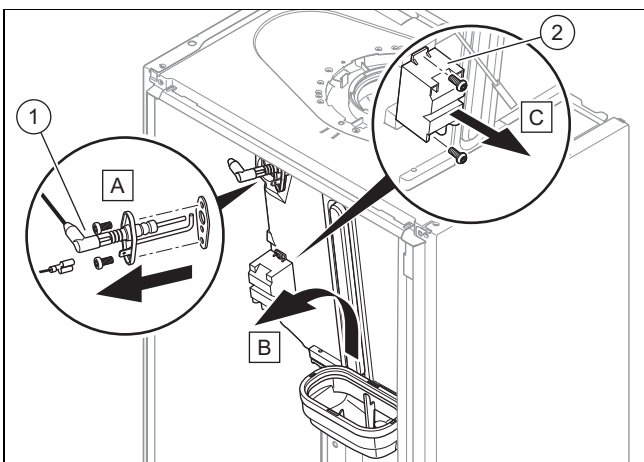

13. Remove the ignition electrode (1).
14. Lift the heat exchanger up slightly and remove it together with the condensate tray.
15. Remove the ignition transformer (2).
16. Install the new heat exchanger in reverse order.

## 13.6.4 Replacing the pump head

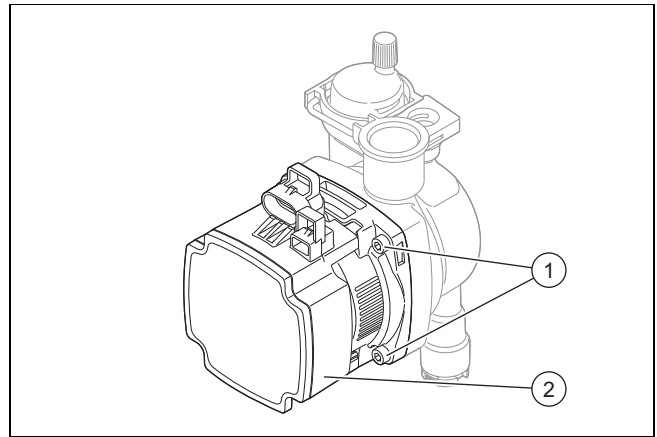

1. Disconnect the pump cables from the electronics box.
2. Undo the four screws (1).
3. Remove the pump head (2).
4. Replace the O-ring.
5. Use four screws to secure the new pump head.
6. Connect the pump cables to the electronics box.

## 13.6.5 Replacing the expansion vessel

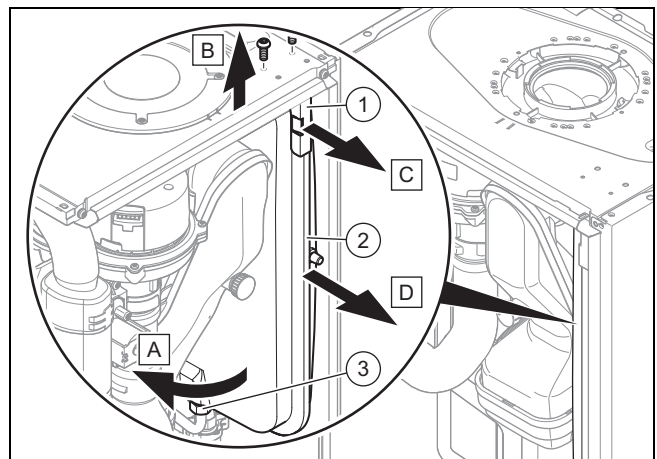

1. Undo the nut (3).
2. Remove both screws on the support plate (1).
3. Remove the support plate .
4. Pull out the expansion vessel (2) towards the front.
5. Insert the new expansion vessel into the product.
6. Screw the new expansion vessel to the water connection. To do this, use a new seal.
7. Attach the support plate using both screws.
8. Fill and purge the product (→ Page 31) and, if required, the heating installation.

# 13 Troubleshooting

## 13.6.6 Replacing the PCB

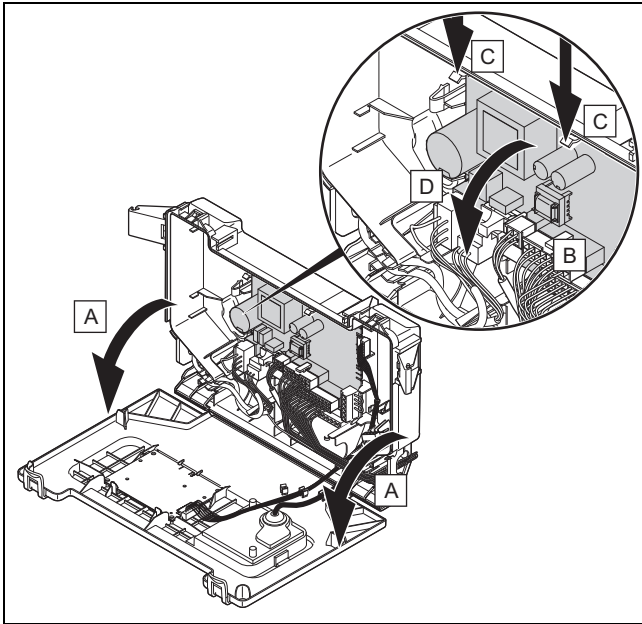

1. Open the electronics box.
2. Pull all of the plugs out from the PCB.
3. Undo the clips on the PCB.
4. Remove the PCB.
5. Install the new PCB in such a way that it clicks into the groove at the bottom and into the clip at the top.
6. Plug in the PCB plugs.
7. Close the electronics box.

## 13.6.7 Replacing the PCB for the user interface

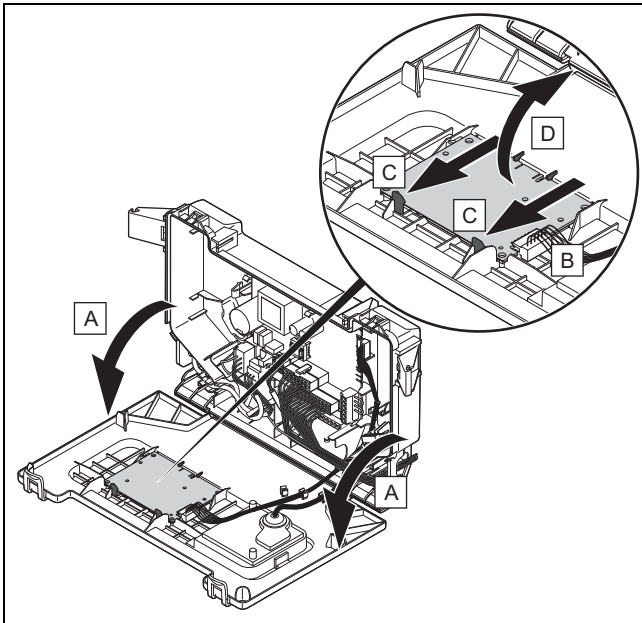

1. Open the electronics box.
2. Pull the plug out of the PCB.
3. Undo the clips on the PCB.
4. Remove the PCB.
5. Install the new PCB in such a way that it clicks into the groove at the bottom and into the clip at the top.
6. Plug in the PCB plug.
7. Close the electronics box.

## 13.6.8 Replacing the expansion relief valve

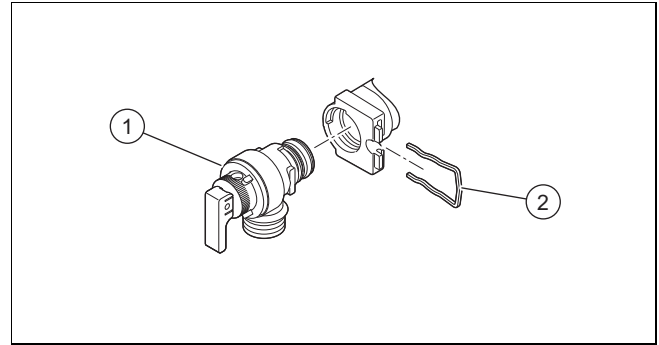

1. Remove the clip (2).
2. Remove the expansion relief valve.
3. Fit the new expansion relief valve with a new O-ring.
4. Reattach the clip (2).

## 13.6.9 Replacing the volume flow sensor

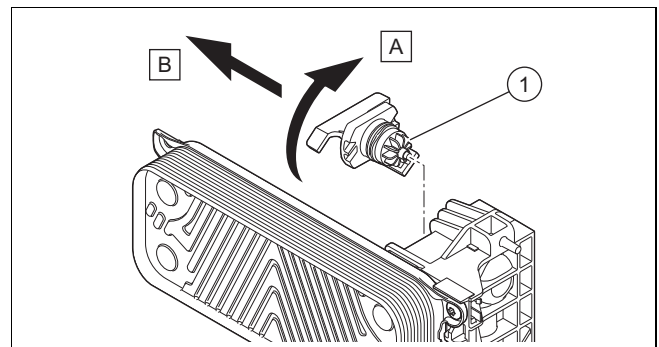

1. Pull out the plug.
2. Remove the volume flow sensor (1).
3. Install the new volume flow sensor.
4. Plug in the plug.

## 13.6.10 Replace the pressure sensor

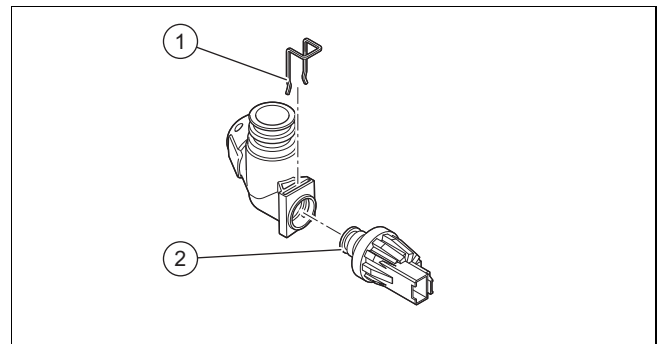

1. Pull out the plug.
2. Remove the clip (1).
3. Remove the pressure sensor (2).
4. Install the new pressure sensor.
5. Reattach the clip (1).

### 13.7 Checking the product for leak-tightness

- ▶ Check that the product is leak-tight. (→ Page 33)

## 14 Decommissioning the product

### 14 Decommissioning the product

- ▶ Switch off the product.
- ▶ Disconnect the product from the power grid.
- ▶ Close the gas stopcock.
- ▶ Close the cold-water stopcock.

### 15 Recycling and disposal

#### Disposing of the packaging

- ▶ Dispose of the packaging correctly.
- ▶ Observe all relevant regulations.
- ▶ For detailed information refer to [www.glow-worm.co.uk](http://www.glow-worm.co.uk).

## Appendix

### A Inspection and maintenance work

The table below lists the manufacturer requirements with respect to minimum inspection and maintenance intervals. If national regulations and directives require shorter inspection and maintenance intervals, you should observe these instead of the intervals listed. Each time inspection and maintenance work is carried out, carry out the required preparatory and completion work.



#### Note

For those appliances which are not part of an annual service agreement/policy, maintenance must be carried out at least every 5 years.

#	Maintenance work	Interval	
1	Record all of the analysis results in the Benchmark service record in these instructions	Annually	
2	Ask the end user whether any significant problems occur when operating the product	Annually	
3	Use the diagnostics system to check the product's fault history	Annually	
4	Visually inspect whether the air/flue pipe and its opening have been installed correctly in accordance with the set-up instructions	Annually	
5	Check that the unit has been installed correctly and the connections have been secured	Annually	
6	Check all of the connections for tightness	Annually	
7	Check that the condensate pipe is in good condition, that it is leak-tight and that the drain is correct	Annually	
8	Check whether all of the externally routed condensate pipes are dimensioned correctly and have been insulated sufficiently (frost protection)	Annually	
9	Check whether the gas flow rate corresponds with the specifications on the data plate and lies within the tolerances specified in these instructions	Annually	
10	If the gas flow rate lies outside of the tolerances specified in these instructions, eliminate the fault in accordance with the regulations and the current technology	Annually	
11	Check the general condition of the product and, if required, eliminate any faults that are found	Annually	
12	Carry out the combustion analysis: Measure the CO content, CO <sub>2</sub> content and the CO/CO <sub>2</sub> ratio. For products with a rear air/flue connection: The combustion analysis can only be carried out when the unit casing has been removed; it is not necessary to test these products for flue gas recirculation	Annually	
13	Check the product's recirculation at the supply air test point on the air/flue pipe. If required, inspect the entire air/flue system and, if necessary, correct the fault	Annually	
14	Disconnect the product from the electrical installation	Annually	
15	Check and, if required, correct the electrical installation	Annually	
16	Remove the unit casing, check the condition of all of the functional components, in particular for leaks, corrosion, rust, etc. and, if required, repair any damage	Annually	
17	Visual inspection of the heat exchanger and burner seals	Annually	
18	Carefully clean the inside of the product: The air passages to the burner must be clear and clean	Annually	
19	Close the installation's gas stopcock and, if required, service valves	Annually	
20	Check the quality of the heating water: Clarity (clouding), correct inhibitor and pH value	Annually	
21	Checking the burner	at regular intervals	
22	Cleaning the heat exchanger	at regular intervals	
23	Check and, if required, replace the insulating mat in the burner area	at regular intervals	
24	Installing the gas-air mixture unit	at regular intervals	
25	Cleaning the condensate trap	Annually	
26	Filling the condensate trap	Annually	

#	Maintenance work	Interval	
27	Check the water flow rate (domestic hot water). Insufficient water flow rate → Check the incoming water supply. Incoming water supply sufficient, water flow rate too low → Clean or replace the strainer in the cold water inlet	Annually	
28	Check the impeller sensor for dirt/damage and, if required, replace it	Annually	
29	Reassemble the product	After each time maintenance work is carried out	
30	Open the service valves, carry out the required leak-tightness test	Annually	
31	Fill the product/heating installation to the filling pressure specified for the system	Annually	
32	Connect the product to the electrical installation	Annually	
33	Run the test operation on the product/heating installation including hot water generation (if available) and, if required, purge the product/heating installation	Annually	
34	Measure the CO content, CO <sub>2</sub> content and the CO/CO <sub>2</sub> ratio again	Annually	

## B Check programmes – Overview



### Note

Since the programme table is used for various products, some programmes may not be visible for the product in question.

Display	Meaning
P.01	Start up the burner at the adjustable heat input: The product is operated after a successful ignition with the set heat input between "0" (0% = Pmin) and "100" (100% = Pmax). The function is activated for 15 minutes.
P.02	Start up the burner at ignition load: The product is operated at ignition load after successful ignition. The function is activated for 15 minutes.
P.03	The product runs in heating mode with the maximum heat input set using diagnostics code d.00.
P.04	Chimney sweep function: If there is a domestic hot water demand, the product runs in domestic hot water mode with maximum heat input. If there is no domestic hot water demand, the product runs in heating mode with the partial heat load that is set using diagnostics code d.00. The function is activated for 15 minutes.
P.05	Filling the product: The prioritising diverter valve is moved to the mid-position. The burner and pump are switched off (to fill or drain the product). If the pressure is lower than 0.05 MPa (0.5 bar) and then is above 0.07 MPa (0.7 bar) for longer than 15 seconds, the automatic purging function is activated. The function is activated for 15 minutes.
P.06	Purging the heating circuit: The prioritising diverter valve is moved to the heating position. The function is activated in the heating circuit for 15 minutes. The pump runs and stops at regular intervals. If required, this function can be manually switched off.
P.07	Purging the domestic hot water circuit: The function is activated in the small domestic hot water circuit for 4 minutes and then in the heating circuit for 1 minute. The pump runs and stops at regular intervals. If required, this function can be manually switched off.
P.10	Safety cut-out check
Automatic purging function	Purging the product: If the pressure is lower than 0.05 MPa (0.5 bar) and then is above 0.07 MPa (0.7 bar) for longer than 15 seconds, the automatic purging function is activated. The function is activated in the small domestic hot water circuit for 4 minutes and then in the heating circuit for 1 minute. This function cannot be manually switched off.

## C Overview of diagnostics codes



### Note

Since the code table is used for various products, some codes may not be visible for the product in question.

Diagnostics code	Parameter	Values		Unit	Increment, select, explanation	Default setting	Own setting
		Min.	Max.				
d.00	Heating maximum output	–	–	kW	The maximum heating output varies depending on the product. → Section "Technical data" Automatic: Unit automatically adjusts the maximum output to the current system demand	→ Section "Technical data"	Adjustable
d.01	Pump overrun time in heating mode	1	60	min	1	5	Adjustable
d.02	Maximum burner anti-cycling time in heating mode	2	60	min	1	20	Adjustable
d.04	Water temperature in the cylinder	Current value		°C	–	–	Not adjustable
d.05	Determined target heating flow temperature	Current value		°C	–	–	Not adjustable
d.06	Target domestic hot water temperature	Current value		°C	(Combi boiler only)	–	Not adjustable
d.07	Target temperature for the domestic hot water cylinder	Current value		°C	–	–	Not adjustable
d.08	Status of the 230 V thermostat	Current value		–	0 = Room thermostat open (no heat requirement) 1 = Room thermostat closed (heat requirement)	–	Not adjustable
d.09	Target heating flow temperature that is set on the eBUS room thermostat	Current value		°C	–	–	Not adjustable
d.10	Status of the internal pump in the heating circuit	Current value		–	off / on	–	Not adjustable
d.11	Status of the heating circuit's shunt pump	Current value		–	off / on	–	Not adjustable
d.13	Status of the domestic hot water circuit's circulation pump	Current value		–	off / on	–	Not adjustable
d.14	Operating mode of the modulating pump	0	5	–	0 = variable rotational speed (auto) 1; 2; 3; 4; 5 = Fixed rotational speeds → Section "Setting the pump output"	0	Adjustable
d.15	Pump speed	Current value		%	–	–	Not adjustable
d.16	Status of the 24 V room thermostat	Current value		–	off = Heating off on = Heating on	–	Not adjustable
d.17	Heating control	–	–	–	off = Flow temperature on = Return temperature (adjustment for underfloor heating. If you have activated the return temperature control, the automatic heating output determination function is not active.)	0	Adjustable

Diagnostics code	Parameter	Values		Unit	Increment, select, explanation	Default setting	Own setting
		Min.	Max.				
d.18	Pump overrun operating mode	1	3	–	1 = Continuous (pump runs permanently) 3 = Eco (intermittent pump operation – for the dissipation of the residual heat after domestic hot water generation at an extremely low heat demand)	1	Adjustable
d.19	Pump mode, 2-stage pump	0	3	–	0 = Burner mode stage 2, pump flow/overrun stage 1 1 = Heating mode and pump run/overrun stage 1, domestic hot water mode stage 2 2 = Automatic heating mode, pump rin/overrun stage 1, domestic hot water mode stage 2 3 = Stage 2	3	Adjustable
d.20	Maximum target domestic hot water temperature	50	60	°C	1	60	Adjustable
d.21	Status of the warm start for domestic hot water	Current value		–	off = Function deactivated on = Function activated and available	–	Not adjustable
d.22	Status of the DHW demand	Current value		–	off = No current requirement on = Current requirement	–	Not adjustable
d.23	Status of the heat demand	Current value		–	off = Heating off (Summer mode) on = Heating on	–	Not adjustable
d.24	Status of the pressure monitor	0	1	–	off = Not switched on = Switched	–	Not adjustable
d.25	Status of the requirement to reheat the cylinder or for the domestic hot water warm start from the eBUS thermostat	Current value		–	off = Function deactivated on = Function activated	–	Not adjustable
d.27	Function of relay 1 (multi-functional module)	1	10	–	1 = Circulation pump 2 = External pump 3 = Cylinder charging pump 4 = Extraction hood 5 = External solenoid valve 6 = Fault display 7 = Solar pump (omitted) 8 = eBUS remote control 9 = Anti-legionella pump 10 = Solar valve	1	Adjustable
d.28	Function of relay 2 (multi-functional module)	1	10	–	1 = Circulation pump 2 = External pump 3 = Cylinder charging pump 4 = Extraction hood 5 = External solenoid valve 6 = Fault display 7 = Solar pump (omitted) 8 = eBUS remote control 9 = Anti-legionella pump 10 = Solar valve	2	Adjustable
d.31	Automatic filling device	0	2	–	0 = Manual 1 = Semi-automatic 2 = Automatic	0	Adjustable
d.33	Fan speed target value	Current value		rpm	Fan speed = Display value x 100	–	Not adjustable
d.34	Value for the fan speed	Current value		rpm	Fan speed = Display value x 100	–	Not adjustable

Diagnostics code	Parameter	Values		Unit	Increment, select, explanation	Default setting	Own setting
		Min.	Max.				
d.35	Position of the prioritising diverter valve	Current value		–	0 = Heating 40 = Mid-position (parallel operation) 100 = Domestic hot water	–	Not adjustable
d.36	Value for the domestic hot water flow rate	Current value		l/min	–	–	Not adjustable
d.39	Water temperature in the solar circuit	Current value		°C	–	–	Not adjustable
d.40	Heating flow temperature	Current value		°C	–	–	Not adjustable
d.41	Heating return temperature	Current value		°C	–	–	Not adjustable
d.43	Heat curve	0.2	4	–	0.1	1.2	Adjustable
d.45	Value for the base point of the heat curve	15	30	–	1	20	Adjustable
d.47	Outdoor temperature	Current value		°C	–	–	Not adjustable
d.50	Correction of the minimum fan speed	0	3000	rpm	1 Fan speed = Display value x 10	600	Adjustable
d.51	Correction of the maximum fan speed	-2500	0	rpm	1 Fan speed = Display value x 10	-1000	Adjustable
d.58	Solar circuit reheating	0	3	–	0 = Boiler's anti-legionella function deactivated 3 = Domestic hot water activated (min. target value 60 °C)	0	Adjustable
d.60	Number of blocks by the temperature cut-out	Current value		–	–	–	Not adjustable
d.61	Number of unsuccessful ignitions	Current value		–	–	–	Not adjustable
d.62	Night set-back	0	30	–	1	0	Adjustable
d.64	Average burner ignition time	Current value		s	–	–	Not adjustable
d.65	Maximum burner ignition time	Current value		s	–	–	Not adjustable
d.66	Activation of the warm start function for domestic hot water	–	–	–	off = Function deactivated on = Function activated	1	Adjustable
d.67	Remaining burner anti-cycling time (setting under d.02)	Current value		min	–	–	Not adjustable
d.68	Number of unsuccessful ignitions at 1st attempt	Current value		–	–	–	Not adjustable
d.69	Number of unsuccessful ignitions at 2nd attempt	Current value		–	–	–	Not adjustable
d.70	Operation of the prioritising diverter valve	0	2	–	0 = Normal operating mode (DHW and heating mode) 1 = Mid-position (parallel operation) 2 = Permanent heating position	0	Adjustable
d.71	Maximum target heating flow temperature	45	80	°C	1	→ Section "Technical data"	Adjustable
d.73	Correction of the domestic hot water warm start temperature	-15	5	K	1	0	Adjustable
d.75	Maximum cylinder post-heating time	20	90	min	1	45	Adjustable

Diagnostics code	Parameter	Values		Unit	Increment, select, explanation	Default setting	Own setting
		Min.	Max.				
d.77	Max. cylinder post-heating	–	–	kW	1 → Section "Technical data"	–	Adjustable
d.80	Running time in heating mode	Current value		h	Running time = Display value x 100	–	Not adjustable
d.81	Running time in domestic hot water mode	Current value		h	Running time = Display value x 100	–	Not adjustable
d.82	Number of burner ignitions in heating mode	Current value		–	Number of ignitions = Display value x 100	–	Not adjustable
d.83	Number of burner ignitions in domestic hot water mode	Current value		–	Number of ignitions = Display value x 100	–	Not adjustable
d.84	Maintenance in	0	3000	h	Number of hours = Display value x 10	300	Not adjustable
d.85	Increase in the min. output (heating and domestic hot water mode)	–	–	kW	1	–	Adjustable
d.88	Flow rate limit value for ignition in domestic hot water mode	0	1	–	0 = 1.7 l/min (no delay) 1 = 3.7 l/min (2 s delay)	0	Adjustable
d.90	Status of the eBUS room thermostat	Current value		–	off = Not connected on = Connected	–	Not adjustable
d.91	Status DCF77	Current value		–	–	–	Not adjustable
d.93	Setting the product code	0	99	–	1 The Device Specific Number (DSN) can be found on the data plate.	–	Adjustable
d.94	Delete fault list	0	1	–	off = No on = Yes	–	Adjustable
d.95	Software versions	–	–	–	1 = Main PCB 2 = Interface PCB	–	Adjustable
d.96	Default setting (reset)	–	–	–	0 = No 1 = Yes	–	Adjustable

## D Status codes – Overview



### Note

Since the code table is used for various products, some codes may not be visible for the product in question.

Status code	Meaning
<b>Displays in heating mode</b>	
S.0	Heating mode: No requirement
S.01	Heating mode: Fan prerun
S.02	Heating mode: Pump prerun
S.03	Heating mode: Burner ignition
S.04	Heating mode: Burner on
S.05	Heating mode: Pump/fan overrun
S.06	Heating mode: Fan overrun
S.07	Heating mode: Pump overrun
S.08	Heating mode: Temporary shutdown after heating procedure
<b>Displays in domestic hot water mode</b>	
S.10	Domestic hot water mode: Requirement
S.11	Domestic hot water mode: Fan prerun

Status code	Meaning
S.13	Domestic hot water mode: Burner ignition
S.14	DHW mode: Burner on
S.15	DHW mode: Pump/fan overrun
S.16	DHW mode: Fan overrun
S.17	DHW mode: Pump overrun
<b>Display in comfort mode with warm start or domestic hot water mode with cylinder</b>	
S.20	Domestic hot water mode: Requirement
S.21	Domestic hot water mode: Fan prerun
S.22	Domestic hot water mode: Pump prerun
S.23	Domestic hot water mode: Burner ignition
S.24	DHW mode: Burner on
S.25	DHW mode: Pump/fan overrun
S.26	DHW mode: Fan overrun
S.27	DHW mode: Pump overrun
S.28	Domestic hot water mode: Temporary shutdown of the burner
<b>Other displays</b>	
S.30	Room thermostat is blocking heating mode.
S.31	No heating demand: Summer mode, eBUS control, waiting period
S.32	Fan waiting time: Fan speed outside of the tolerance values
S.33	Forced fan operation until the pressure monitor is switched
S.34	Frost protection active
S.39	Underfloor heating contact open
S.41	Water pressure too high
S.42	Flue non-return flap closed
S.46	Frost protection mode (Comfort): Minimum load
S.53	Product in waiting period / operating block function due to water deficiency (flow/return spread too large)
S.54	Waiting period: Water deficiency in the circuit (flow/return spread too large)
S.76	Maintenance message: Check the water pressure
S.88	Product purging active
S.91	Maintenance: Demo mode
S.96	Automatic test programme: Return temperature sensor, heating demands blocked.
S.97	Automatic test programme: Water pressure sensor, heating demands blocked.
S.98	Automatic test programme: Return temperature sensor, heating demands blocked.
S.99	Internal automatic test programmes
S.108	Purging the combustion chamber, fan in operation
S.109	Product's standby mode activated

## E Overview of fault codes



### Note

Since the code table is used for various products, some codes may not be visible for the product in question.

Fault code	Meaning	Possible cause
<b>F.00</b>	Fault: Flow temperature sensor	NTC plug not plugged in or has come loose, multiple plug on the PCB not plugged in correctly, interruption in cable harness, NTC sensor defective
<b>F.01</b>	Fault: Return temperature sensor	NTC plug not plugged in or has come loose, multiple plug on the PCB not plugged in correctly, interruption in cable harness, NTC sensor defective
<b>F.10</b>	Short circuit: Flow temperature sensor	NTC sensor defective, short circuit in the cable harness, cable/housing
<b>F.11</b>	Short circuit: Return temperature sensor	NTC sensor defective, short circuit in the cable harness, cable/housing

Fault code	Meaning	Possible cause
F.12 and F.91	Short circuit: Cylinder temperature sensor	NTC sensor defective, short circuit in the cable harness, cable/housing
F.13	Short circuit: Temperature sensor for the domestic hot water cylinder	NTC sensor defective, short circuit in the cable harness, cable/housing
F.20	Safety shutdown: Overheating temperature reached	Incorrect earth connection between cable harness and product, flow or return NTC defective (loose connection), stray spark via ignition cable, ignition plug or ignition electrode
F.22	Safety shutdown: Water deficiency in the boiler	No or insufficient water in the product, water pressure sensor defective, cable to the pump or to the water pressure sensor loose/not connected/defective
F.23	Safety shutdown: Temperature spread too great (NTC1/NTC2)	Pump blocked, insufficient pump output, air in product, flow and return NTC sensors connected the wrong way round
F.24	Safety shutdown: Temperature rise too fast	Pump blocked, insufficient pump output, air in product, system pressure too low, non-return valve blocked/incorrectly installed
F.25	Safety shutdown: Flue gas temperature too high	Break in plug connection for optional flue gas safety cut-out (SCO), break in cable harness
F.27	Safety shutdown: Fault in flame detection	Moisture on the electronics, electronics (flame monitor) defective, gas solenoid valve leaking
F.28	Fault: Ignition unsuccessful when starting up	Gas meter defective or gas pressure switch has triggered, air in gas, gas flow pressure too low, thermal cut-out has triggered, incorrect gas injector, incorrect spare gas valve assembly, fault on the gas valve assembly, multiple plug on PCB incorrectly plugged in, break in cable harness, ignition system (ignition transformer, ignition cable, ignition plug, ignition electrode) defective, ionisation flow interrupted (cable, electrode), incorrect earthing of product, electronics defective Condensate siphon blocked
F.29	Fault: Flame loss	Gas supply temporarily stopped, flue gas recirculation, incorrect earthing of product, ignition transformer has spark failure Condensate siphon blocked
F.32	Fan frost protection function active: Fan speed outside the tolerance values	Plug on fan not correctly plugged in, multiple plug on PCB not correctly plugged in, break in cable harness, fan blocked, Hall sensor defective, electronics defective
F.49	eBUS fault: Voltage too low	Short circuit on eBUS, eBUS overload or two power supplies with different polarities on the eBUS
F.61	Fault: Gas valve assembly control	Short circuit/short-to-ground in cable harness to gas valve assembly, gas valve assembly defective (coils shorted to earth), electronics defective
F.62	Fault: Gas valve switch-off control	Delayed switch-off of gas valve assembly, delayed extinguishing of flame signal, gas valve assembly leaking, electronics defective
F.63	Fault: EEPROM	Electronics defective
F.64	Fault: Electronics / sensor / analogue-to-digital converter	Flow or return NTC short circuited, electronics defective
F.65	Fault: Electronics temperature too high	Electronics overheating due to external influences, electronics defective
F.67	Value sent back by ASIC is incorrect (flame signal)	Implausible flame signal, electronics defective
F.68	Fault: Unstable flame (analogue input)	Air in gas, gas flow pressure too low, incorrect air ratio, incorrect gas injector, ionisation flow interruption (cable, electrode)
F.70	Invalid product code (DSN)	Display and PCB replaced at same time and Device Specific Number not reset, wrong or missing output coding resistor
F.71	Fault: Flow/return temperature sensor	Flow temperature sensor signalling constant value: Flow temperature sensor incorrectly positioned on flow pipe, flow temperature sensor defective
F.72	Fault: Deviation in the water pressure sensor/return temperature sensor	Flow/return NTC temperature difference too great → flow and/or return temperature sensor defective
F.73	Fault: Water pressure sensor not connected or has short-circuited	Interruption/short circuit of water pressure sensor, interruption/short circuit to GND in supply pipe to water pressure sensor or water pressure sensor defective
F.74	Fault: Electrical problem in the water pressure sensor	Line to water pressure sensor has a short circuit to 5 V/24 V or internal fault in the water pressure sensor
F.75	Fault: Pressure sensor	Pressure switch defective
F.76	The safety cut-out in the primary heat exchanger is defective	Safety cut-out feedback does not match the gas valve assembly feedback
F.77	Fault: Condensate or smoke	No response, flue non-return flap defective

<b>Fault code</b>	<b>Meaning</b>	<b>Possible cause</b>
<b>F.78</b>	Interruption to DHW outlet sensor at external control	UK link box is connected, but domestic hot water NTC not bridged
<b>F.83</b>	Fault: Dry fire	When the burner starts, the temperature change registered at the flow or return temperature sensor is non-existent or too small: Insufficient water in the product, the flow or return temperature sensor is not in the correct position on the pipe
<b>F.84</b>	Fault: Flow/return temperature sensor	Values not consistent, difference < -6 K Flow and return temperature sensors signalling implausible values: Flow and return temperature sensors have been inverted, flow and return temperature sensors have not been correctly installed
<b>F.85</b>	Fault: Temperature sensor	The flow and/or return temperature sensors have been installed on the same pipe/incorrect pipe Temperature sensor not connected or is connected incorrectly
<b>F.86</b>	Fault: Underfloor heating contact	Underfloor heating contact open, sensor disconnected or defective
<b>F.87</b>	Fault: Electrodes	Electrodes not connected or they are connected incorrectly, short circuit in the cable harness
<b>F.88</b>	Fault: Gas valve assembly	Gas valve assembly not connected or it is connected incorrectly, short circuit in the cable harness
<b>F.89</b>	Fault: Pump	Pump not connected or it is connected incorrectly, incorrect pump connected, short circuit in the cable harness
<b>F.97</b>	Fault: Main PCB self-test failed	Main PCB defective
Connection	No communication between the main PCB and the user interface	Electronics defective

**F Wiring diagram: Combi boiler**

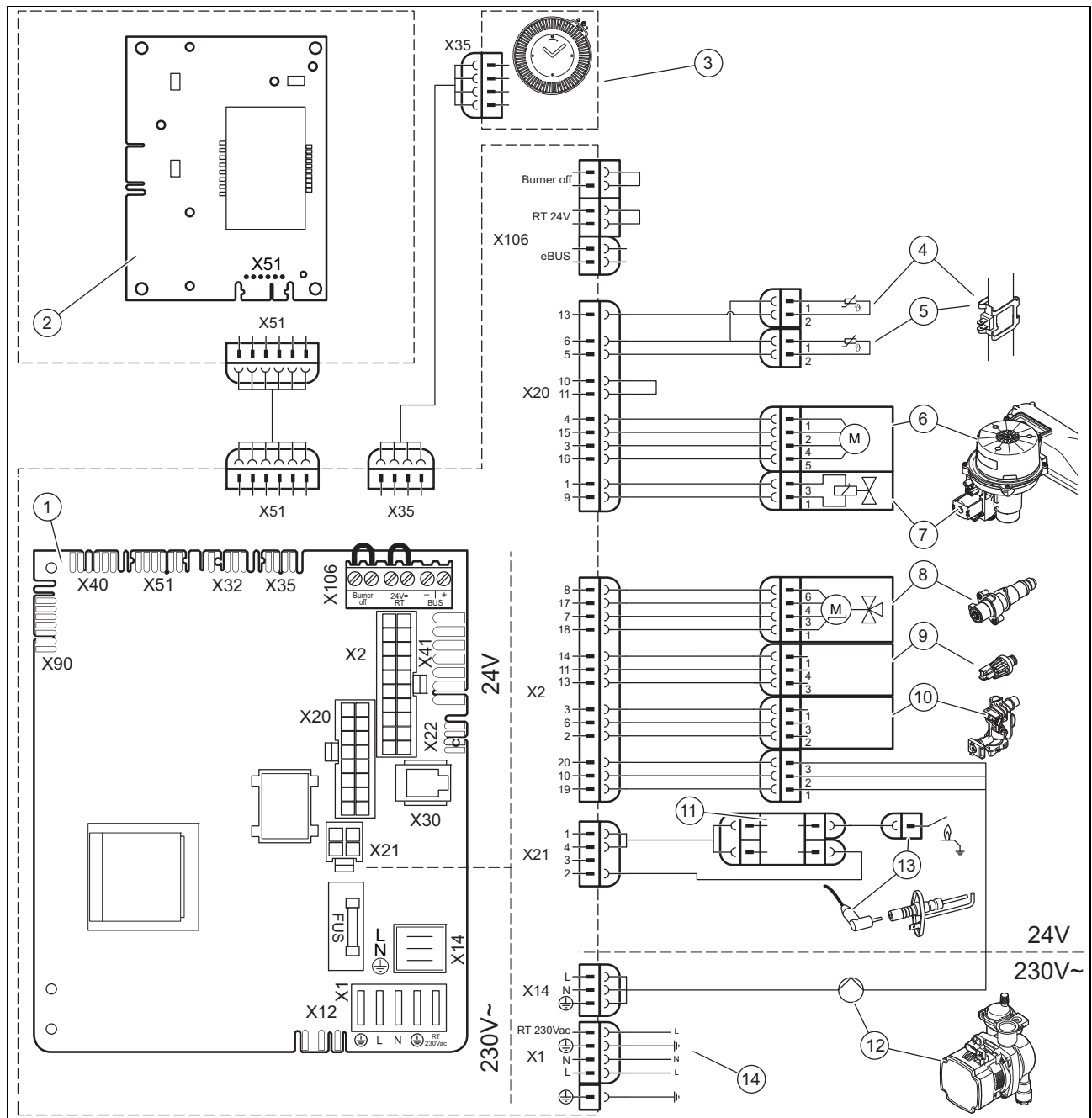

- |   |  |    |  |
|---|--|----|--|
| 1 | Main PCB                                 | 8  | 3-port diverter valve                              |
| 2 | Interface PCB                            | 9  | Pressure sensor                                    |
| 3 | Timer                                    | 10 | Flow rate sensor                                   |
| 4 | Temperature sensor on the heating flow   | 11 | External ignition transformer                      |
| 5 | Temperature sensor on the heating return | 12 | Heating pump                                       |
| 6 | Fan                                      | 13 | Ionisation and ignition electrode                  |
| 7 | Gas valve assembly                       | 14 | Main power supply and connection for 230 V control |

**G Wiring diagram: Combi boiler (35 kW)**

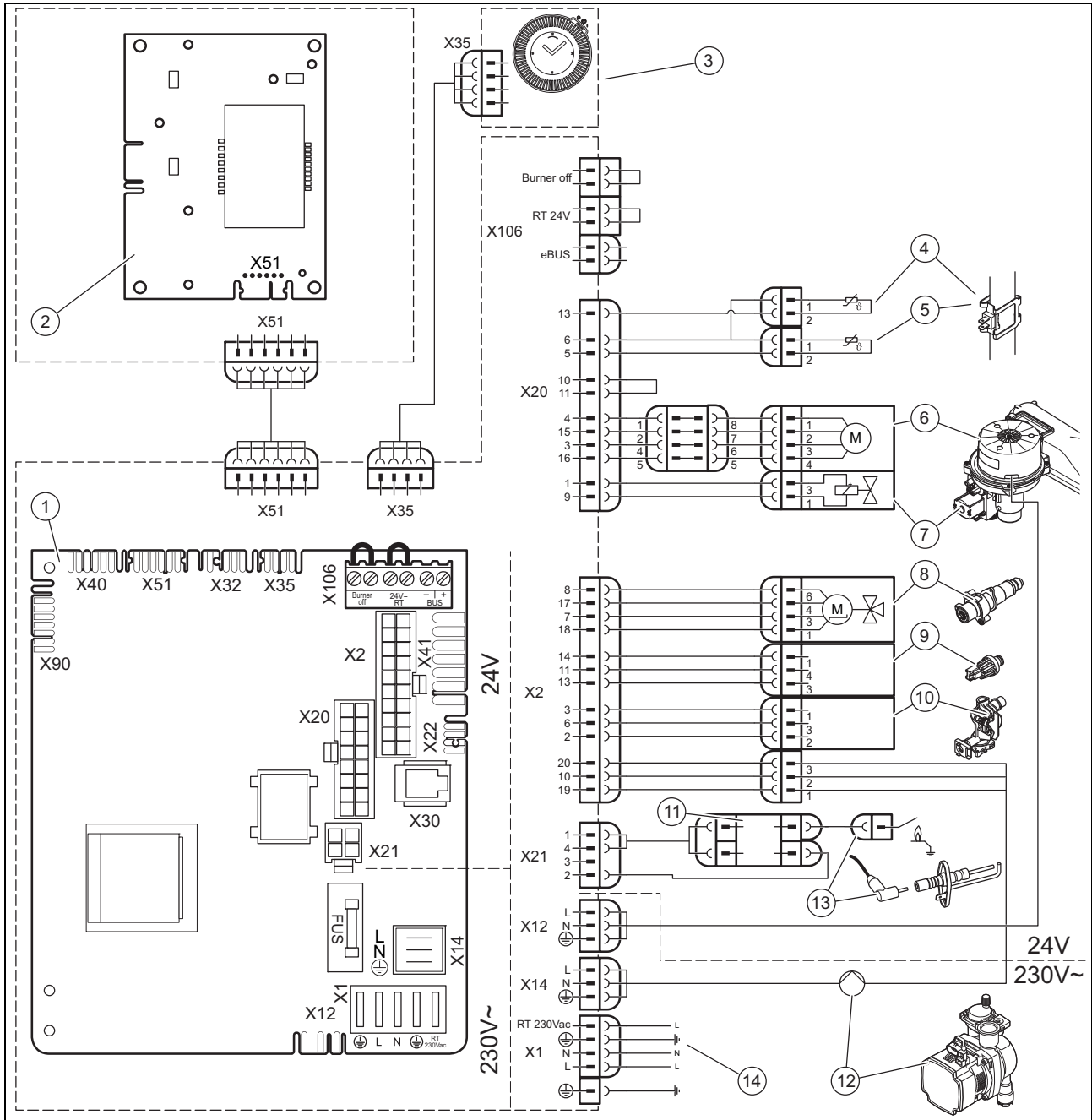

- |   |  |    |  |
|---|--|----|--|
| 1 | Main PCB                                 | 8  | 3-port diverter valve                              |
| 2 | Interface PCB                            | 9  | Pressure sensor                                    |
| 3 | Timer                                    | 10 | Flow rate sensor                                   |
| 4 | Temperature sensor on the heating flow   | 11 | External ignition transformer                      |
| 5 | Temperature sensor on the heating return | 12 | Heating pump                                       |
| 6 | Fan                                      | 13 | Ionisation and ignition electrode                  |
| 7 | Gas valve assembly                       | 14 | Main power supply and connection for 230 V control |

## H Commissioning Checklist

# Benchmark Commissioning & Warranty Validation Service Record

It is a requirement that the boiler is installed and commissioned to the manufacturers' instructions and the data fields on the commissioning checklist completed in full.

To instigate the boiler warranty the boiler needs to be registered with the manufacturer within one month of the installation. The warranty rests with the end-user (consumer), and they should be made aware it is ultimately their responsibility to register with the manufacturer, within the allotted time period.

It is essential that the boiler is serviced in line with the manufacturers' recommendations, at least annually. This must be carried out by a competent Gas Safe registered engineer. The service details should be recorded on the Benchmark Service and Interim Boiler Work Record and left with the householder. Failure to comply with the manufacturers' servicing instructions and requirements will invalidate the warranty.



[www.hhic.co.uk](http://www.hhic.co.uk)

**This Commissioning Checklist is to be completed in full by the competent person who commissioned the boiler as a means of demonstrating compliance with the appropriate Building Regulations and then handed to the customer to keep for future reference.**

Failure to install and commission according to the manufacturers' instructions and complete this Benchmark Commissioning Checklist will invalidate the warranty. This does not affect the customer's statutory rights.

\* All installations in England and Wales must be notified to Local Authority Building Control (LABC) either directly or through a Competent Persons Scheme. A Building Regulations Compliance Certificate will then be issued to the customer.

© Heating and Hotwater Industry Council (HHIC)



[www.centralheating.co.uk](http://www.centralheating.co.uk)

### GAS BOILER SYSTEM COMMISSIONING CHECKLIST & WARRANTY VALIDATION RECORD

Address:															
Boiler make and model:															
Boiler serial number:															
Commissioned by (PRINT NAME):						Gas Safe registration number:									
Company name:						Telephone number:									
Company email:						Company address:									
										Commissioning date:					
Heating and hot water system complies with the appropriate Building Regulations?											Yes				
Optional: Building Regulations Notification Number (if applicable):															
Time, temperature control and boiler interlock provided for central heating and hot water											Yes				
Boiler Plus requirements (tick the appropriate box(s))															
Boiler Plus option chosen for combination boiler in ENGLAND						Weather compensation		Smart thermostat with automation and optimisation							
						Load compensation		Flue Gas Heat Recovery							
Time and temperature control to hot water			Cylinder thermostat and programmer/timer						Combination boiler						
Zone valves			pre-existing		Fitted		Not required								
Thermostatic radiator valves			pre-existing		Fitted		Not required								
Automatic bypass to system			pre-existing		Fitted		Not required								
Underfloor heating			pre-existing		Fitted		Not required								
Water quality															
The system has been flushed, cleaned and a suitable inhibitor applied upon final fill, in accordance with BS7593 and boiler manufacturers' instructions											Yes				
What system cleaner was used?						Brand:			Product:						
What inhibitor was used?						Brand:			Product:						
Primary water system filter			pre-existing		Fitted		Not required								
CENTRAL HEATING MODE measure and record (as appropriate)															
Gas rate (for combination boilers complete DHW mode gas rate)				m <sup>3</sup> /hr		or		ft <sup>3</sup> /hr							
Central heating output left at factory settings?											Yes	No			
If no, what is the maximum central heating output selected?											kW				
Dynamic gas inlet pressure											mbar				
Central heating flow temperature											°C				
Central heating return temperature											°C				
System correctly balanced/rebalanced?											Yes				
COMBINATION BOILERS ONLY															
Is the installation in a hard water area (above 200ppm)?											Yes	No			
Water scale reducer/softener			pre-existing		Fitted		Not required								
What type of scale reducer/softener has been fitted?						Brand:			Product:						
Water meter fitted?											Yes	No			
If yes- DHW expansion vessel			pre-existing		Fitted		Not required								
Pressure reducing valve			pre-existing		Fitted		Not required								
DOMESTIC HOT WATER MODE Measure and record															
Gas rate				m <sup>3</sup> /hr		or		ft <sup>3</sup> /hr							
Dynamic gas inlet pressure at maximum rate											mbar				
Cold water inlet temperature											°C				
Hot water has been checked at all outlets											Yes	Temperature	°C		
CONDENSATE DISPOSAL															
The condensate drain has been installed in accordance with the manufacturers' instructions and/or BS5546/BS6798											Yes				
Point of termination						Internal		External (only where internal termination impractical)							
Method of disposal						Gravity		Pumped							
ALL INSTALLATIONS															
Record the following		At max rate:		CO		ppm		CO <sub>2</sub>		%		CO/CO <sub>2</sub>		Ratio	
		At min rate (where possible)		CO		ppm		CO <sub>2</sub>		%		CO/CO <sub>2</sub>		Ratio	
Where possible, has a flue integrity check been undertaken in accordance with manufacturers' instructions, and readings are correct?											Yes				
The operation of the boiler and system controls have been demonstrated to and understood by the customer											Yes				
The manufacturers' literature, including Benchmark Checklist and Service Record, has been explained and left with the customer											Yes				
Commissioning Engineer's signature															
Customer's signature (To confirm satisfactory demonstration and receipt of manufacturers' literature)															

\* All installations in England and Wales must be notified to Local Authority Building Control (LABC) either directly or through a Competent Persons Scheme. A Building Regulations Compliance Certificate will then be issued to the customer.

© Heating and Hotwater Industry Council (HHIC)



www.centralheating.co.uk

## SERVICE & INTERIM BOILER WORK RECORD

It is recommended that your boiler and heating system are regularly serviced and maintained, in line with manufacturers' instructions, and that the appropriate service / interim work record is completed.

### Service provider

When completing a service record (as below), please ensure you have carried out the service as described in the manufacturers' instructions. Always use the manufacturers' specified spare parts.

<b>SERVICE/INTERIM WORK ON BOILER</b> <small>delete as appropriate</small> Date:				
Engineer name:		Company name:		
Telephone N°:		Gas Safe registration N°:		
Max rate	CO	ppm	CO <sub>2</sub>	% CO/CO <sub>2</sub>
Min rate	CO	ppm	CO <sub>2</sub>	% CO/CO <sub>2</sub>
Where possible, has a flue integrity check been undertaken in accordance with manufacturers' instructions, and readings are correct?*				yes
Gas rate:	m <sup>3</sup> /h	OR	ft <sup>3</sup> /h	
Were parts fitted? <small>delete as appropriate</small>		Yes	No	
Parts fitted:				
System inhibitor concentration has been checked and appropriate action taken, in accordance with BS 7593 and boiler manufacturers' instructions. *				yes n/a
Comments:				
Signature:				

\*A System inhibitor efficacy test is required on every annual service in accordance with the manufacturers' instructions and BS 7593. It is only acceptable to not have undertaken this if the service engineers attendance visit was in between annual services to attend a non-water facing component.

<b>SERVICE/INTERIM WORK ON BOILER</b> <small>delete as appropriate</small> Date:				
Engineer name:		Company name:		
Telephone N°:		Gas Safe registration N°:		
Max rate	CO	ppm	CO <sub>2</sub>	% CO/CO <sub>2</sub>
Min rate	CO	ppm	CO <sub>2</sub>	% CO/CO <sub>2</sub>
Where possible, has a flue integrity check been undertaken in accordance with manufacturers' instructions, and readings are correct?*				yes
Gas rate:	m <sup>3</sup> /h	OR	ft <sup>3</sup> /h	
Were parts fitted? <small>delete as appropriate</small>		Yes	No	
Parts fitted:				
System inhibitor concentration has been checked and appropriate action taken, in accordance with BS 7593 and boiler manufacturers' instructions. *				yes n/a
Comments:				
Signature:				

\*A System inhibitor efficacy test is required on every annual service in accordance with the manufacturers' instructions and BS 7593. It is only acceptable to not have undertaken this if the service engineers attendance visit was in between annual services to attend a non-water facing component.

<b>SERVICE/INTERIM WORK ON BOILER</b> <small>delete as appropriate</small> Date:				
Engineer name:		Company name:		
Telephone N°:		Gas Safe registration N°:		
Max rate	CO	ppm	CO <sub>2</sub>	% CO/CO <sub>2</sub>
Min rate	CO	ppm	CO <sub>2</sub>	% CO/CO <sub>2</sub>
Where possible, has a flue integrity check been undertaken in accordance with manufacturers' instructions, and readings are correct?*				yes
Gas rate:	m <sup>3</sup> /h	OR	ft <sup>3</sup> /h	
Were parts fitted? <small>delete as appropriate</small>		Yes	No	
Parts fitted:				
System inhibitor concentration has been checked and appropriate action taken, in accordance with BS 7593 and boiler manufacturers' instructions. *				yes n/a
Comments:				
Signature:				

\*A System inhibitor efficacy test is required on every annual service in accordance with the manufacturers' instructions and BS 7593. It is only acceptable to not have undertaken this if the service engineers attendance visit was in between annual services to attend a non-water facing component.

<b>SERVICE/INTERIM WORK ON BOILER</b> <small>delete as appropriate</small> Date:				
Engineer name:		Company name:		
Telephone N°:		Gas Safe registration N°:		
Max rate	CO	ppm	CO <sub>2</sub>	% CO/CO <sub>2</sub>
Min rate	CO	ppm	CO <sub>2</sub>	% CO/CO <sub>2</sub>
Where possible, has a flue integrity check been undertaken in accordance with manufacturers' instructions, and readings are correct?*				yes
Gas rate:	m <sup>3</sup> /h	OR	ft <sup>3</sup> /h	
Were parts fitted? <small>delete as appropriate</small>		Yes	No	
Parts fitted:				
System inhibitor concentration has been checked and appropriate action taken, in accordance with BS 7593 and boiler manufacturers' instructions. *				yes n/a
Comments:				
Signature:				

\*A System inhibitor efficacy test is required on every annual service in accordance with the manufacturers' instructions and BS 7593. It is only acceptable to not have undertaken this if the service engineers attendance visit was in between annual services to attend a non-water facing component.

<b>SERVICE/INTERIM WORK ON BOILER</b> <small>delete as appropriate</small> Date:				
Engineer name:		Company name:		
Telephone N°:		Gas Safe registration N°:		
Max rate	CO	ppm	CO <sub>2</sub>	% CO/CO <sub>2</sub>
Min rate	CO	ppm	CO <sub>2</sub>	% CO/CO <sub>2</sub>
Where possible, has a flue integrity check been undertaken in accordance with manufacturers' instructions, and readings are correct?*				yes
Gas rate:	m <sup>3</sup> /h	OR	ft <sup>3</sup> /h	
Were parts fitted? <small>delete as appropriate</small>		Yes	No	
Parts fitted:				
System inhibitor concentration has been checked and appropriate action taken, in accordance with BS 7593 and boiler manufacturers' instructions. *				yes n/a
Comments:				
Signature:				

\*A System inhibitor efficacy test is required on every annual service in accordance with the manufacturers' instructions and BS 7593. It is only acceptable to not have undertaken this if the service engineers attendance visit was in between annual services to attend a non-water facing component.

<b>SERVICE/INTERIM WORK ON BOILER</b> <small>delete as appropriate</small> Date:				
Engineer name:		Company name:		
Telephone N°:		Gas Safe registration N°:		
Max rate	CO	ppm	CO <sub>2</sub>	% CO/CO <sub>2</sub>
Min rate	CO	ppm	CO <sub>2</sub>	% CO/CO <sub>2</sub>
Where possible, has a flue integrity check been undertaken in accordance with manufacturers' instructions, and readings are correct?*				yes
Gas rate:	m <sup>3</sup> /h	OR	ft <sup>3</sup> /h	
Were parts fitted? <small>delete as appropriate</small>		Yes	No	
Parts fitted:				
System inhibitor concentration has been checked and appropriate action taken, in accordance with BS 7593 and boiler manufacturers' instructions. *				yes n/a
Comments:				
Signature:				

\*A System inhibitor efficacy test is required on every annual service in accordance with the manufacturers' instructions and BS 7593. It is only acceptable to not have undertaken this if the service engineers attendance visit was in between annual services to attend a non-water facing component.

\* All installations in England and Wales must be notified to Local Authority Building Control (LABC) either directly or through a Competent Persons Scheme. A Building Regulations Compliance Certificate will then be issued to the customer.

© Heating and Hotwater Industry Council (HHIC)



www.centralheating.co.uk

### SERVICE & INTERIM BOILER WORK RECORD

It is recommended that your boiler and heating system are regularly serviced and maintained, in line with manufacturers' instructions, and that the appropriate service / interim work record is completed.

**Service provider**

When completing a service record (as below), please ensure you have carried out the service as described in the manufacturers' instructions. Always use the manufacturers' specified spare parts.

<b>SERVICE/INTERIM WORK ON BOILER</b> <small>delete as appropriate</small>					Date:
Engineer name:		Company name:			
Telephone N°:		Gas Safe registration N°:			
Max rate	CO	ppm	CO <sub>2</sub>	%	CO/CO <sub>2</sub>
Min rate	CO	ppm	CO <sub>2</sub>	%	CO/CO <sub>2</sub>
Where possible, has a flue integrity check been undertaken in accordance with manufacturers' instructions, and readings are correct?"					yes
Gas rate:	m <sup>3</sup> /h	OR	ft <sup>3</sup> /h		
Were parts fitted? <small>delete as appropriate</small>		Yes	No		
Parts fitted:					
System inhibitor concentration has been checked and appropriate action taken, in accordance with BS 7593 and boiler manufacturers' instructions. *					yes n/a
Comments:					
Signature:					

\*A System inhibitor efficacy test is required on every annual service in accordance with the manufacturers' instructions and BS 7593. It is only acceptable to not have undertaken this if the service engineers attendance visit was in between annual services to attend a non-water facing component.

<b>SERVICE/INTERIM WORK ON BOILER</b> <small>delete as appropriate</small>					Date:
Engineer name:		Company name:			
Telephone N°:		Gas Safe registration N°:			
Max rate	CO	ppm	CO <sub>2</sub>	%	CO/CO <sub>2</sub>
Min rate	CO	ppm	CO <sub>2</sub>	%	CO/CO <sub>2</sub>
Where possible, has a flue integrity check been undertaken in accordance with manufacturers' instructions, and readings are correct?"					yes
Gas rate:	m <sup>3</sup> /h	OR	ft <sup>3</sup> /h		
Were parts fitted? <small>delete as appropriate</small>		Yes	No		
Parts fitted:					
System inhibitor concentration has been checked and appropriate action taken, in accordance with BS 7593 and boiler manufacturers' instructions. *					yes n/a
Comments:					
Signature:					

\*A System inhibitor efficacy test is required on every annual service in accordance with the manufacturers' instructions and BS 7593. It is only acceptable to not have undertaken this if the service engineers attendance visit was in between annual services to attend a non-water facing component.

<b>SERVICE/INTERIM WORK ON BOILER</b> <small>delete as appropriate</small>					Date:
Engineer name:		Company name:			
Telephone N°:		Gas Safe registration N°:			
Max rate	CO	ppm	CO <sub>2</sub>	%	CO/CO <sub>2</sub>
Min rate	CO	ppm	CO <sub>2</sub>	%	CO/CO <sub>2</sub>
Where possible, has a flue integrity check been undertaken in accordance with manufacturers' instructions, and readings are correct?"					yes
Gas rate:	m <sup>3</sup> /h	OR	ft <sup>3</sup> /h		
Were parts fitted? <small>delete as appropriate</small>		Yes	No		
Parts fitted:					
System inhibitor concentration has been checked and appropriate action taken, in accordance with BS 7593 and boiler manufacturers' instructions. *					yes n/a
Comments:					
Signature:					

\*A System inhibitor efficacy test is required on every annual service in accordance with the manufacturers' instructions and BS 7593. It is only acceptable to not have undertaken this if the service engineers attendance visit was in between annual services to attend a non-water facing component.

<b>SERVICE/INTERIM WORK ON BOILER</b> <small>delete as appropriate</small>					Date:
Engineer name:		Company name:			
Telephone N°:		Gas Safe registration N°:			
Max rate	CO	ppm	CO <sub>2</sub>	%	CO/CO <sub>2</sub>
Min rate	CO	ppm	CO <sub>2</sub>	%	CO/CO <sub>2</sub>
Where possible, has a flue integrity check been undertaken in accordance with manufacturers' instructions, and readings are correct?"					yes
Gas rate:	m <sup>3</sup> /h	OR	ft <sup>3</sup> /h		
Were parts fitted? <small>delete as appropriate</small>		Yes	No		
Parts fitted:					
System inhibitor concentration has been checked and appropriate action taken, in accordance with BS 7593 and boiler manufacturers' instructions. *					yes n/a
Comments:					
Signature:					

\*A System inhibitor efficacy test is required on every annual service in accordance with the manufacturers' instructions and BS 7593. It is only acceptable to not have undertaken this if the service engineers attendance visit was in between annual services to attend a non-water facing component.

<b>SERVICE/INTERIM WORK ON BOILER</b> <small>delete as appropriate</small>					Date:
Engineer name:		Company name:			
Telephone N°:		Gas Safe registration N°:			
Max rate	CO	ppm	CO <sub>2</sub>	%	CO/CO <sub>2</sub>
Min rate	CO	ppm	CO <sub>2</sub>	%	CO/CO <sub>2</sub>
Where possible, has a flue integrity check been undertaken in accordance with manufacturers' instructions, and readings are correct?"					yes
Gas rate:	m <sup>3</sup> /h	OR	ft <sup>3</sup> /h		
Were parts fitted? <small>delete as appropriate</small>		Yes	No		
Parts fitted:					
System inhibitor concentration has been checked and appropriate action taken, in accordance with BS 7593 and boiler manufacturers' instructions. *					yes n/a
Comments:					
Signature:					

\*A System inhibitor efficacy test is required on every annual service in accordance with the manufacturers' instructions and BS 7593. It is only acceptable to not have undertaken this if the service engineers attendance visit was in between annual services to attend a non-water facing component.

<b>SERVICE/INTERIM WORK ON BOILER</b> <small>delete as appropriate</small>					Date:
Engineer name:		Company name:			
Telephone N°:		Gas Safe registration N°:			
Max rate	CO	ppm	CO <sub>2</sub>	%	CO/CO <sub>2</sub>
Min rate	CO	ppm	CO <sub>2</sub>	%	CO/CO <sub>2</sub>
Where possible, has a flue integrity check been undertaken in accordance with manufacturers' instructions, and readings are correct?"					yes
Gas rate:	m <sup>3</sup> /h	OR	ft <sup>3</sup> /h		
Were parts fitted? <small>delete as appropriate</small>		Yes	No		
Parts fitted:					
System inhibitor concentration has been checked and appropriate action taken, in accordance with BS 7593 and boiler manufacturers' instructions. *					yes n/a
Comments:					
Signature:					

\*A System inhibitor efficacy test is required on every annual service in accordance with the manufacturers' instructions and BS 7593. It is only acceptable to not have undertaken this if the service engineers attendance visit was in between annual services to attend a non-water facing component.

\* All installations in England and Wales must be notified to Local Authority Building Control (LABC) either directly or through a Competent Persons Scheme. A Building Regulations Compliance Certificate will then be issued to the customer.

© Heating and Hotwater Industry Council (HHIC)



www.centralheating.co.uk

## I Pipe lengths for the air/flue pipe

### I.1 Length of the C13 type air/flue pipe

Validity: C13 type air/flue pipe

	Diameter of the air/flue pipe	
	Dia. 60/100 (L)	Dia. 80/125 (L)
	C13 type air/flue pipe	C13 type air/flue pipe
Energy7 25c -A (H-GB)	≤ 10 m	≤ 25 m
Energy7 30c -A (H-GB)	≤ 10 m	≤ 25 m
Energy7 35c -A (H-GB)	≤ 10 m	≤ 25 m

### I.2 Length of the C33 type air/flue pipe

Validity: C33 type air/flue pipe

	Diameter of the air/flue pipe	
	Dia. 60/100 (L)	Dia. 80/125 (L)
	C33 type air/flue pipe	C33 type air/flue pipe
Energy7 25c -A (H-GB)	≤ 10 m	≤ 25 m
Energy7 30c -A (H-GB)	≤ 10 m	≤ 25 m
Energy7 35c -A (H-GB)	≤ 10 m	≤ 25 m

### I.3 Length of the C43 type air/flue pipe

Validity: C43 type air/flue pipe

	Diameter of the air/flue pipe
	Dia. 60/100 (L)
	C43 type air/flue pipe
Energy7 25c -A (H-GB)	≤ 5 m
Energy7 30c -A (H-GB)	≤ 5 m
Energy7 35c -A (H-GB)	≤ 5 m

## Index

<b>A</b>			
Air/flue pipe, horizontal wall duct.....	19		
Air/flue pipe, installing .....	26		
Air/flue pipe, type C13 .....	19		
Air/flue pipe, type C33 .....	19		
Air/flue pipe, vertical roof duct .....	19		
Article number .....	11		
<b>B</b>			
Burner anti-cycling time .....	35		
Burner anti-cycling time, resetting .....	35		
Burner anti-cycling time, setting .....	35		
Burner, checking .....	38		
Bypass valve .....	35		
<b>C</b>			
CE marking .....	12		
Check programmes, using .....	28		
Checking the pre-charge pressure of the expansion vessel .....	39		
Cleaning the condensate siphon .....	38		
CO <sub>2</sub> content			
Checking .....	33, 37		
Completing inspection work .....	39		
Completing maintenance work .....	39		
Condensate discharge pipe .....	24		
Condensate siphon, filling .....	30		
Control .....	27		
<b>D</b>			
Data plate .....	12		
Decommissioning .....	44		
Decommissioning the product .....	44		
Diagnostics codes, using .....	28		
Disposal, packaging .....	44		
Disposing of the packaging .....	44		
Documents .....	11		
<b>E</b>			
Expansion relief valve .....	42		
<b>F</b>			
Fault codes .....	40		
Fault memory .....	40		
Fault messages .....	40		
Fault symbol .....	28		
Flow rate-pressure curves .....	35		
Frost protection .....	13		
<b>G</b>			
Garantie .....	7		
Gas Council Number .....	11		
Gas family check .....	31		
Gas flow rate .....	22, 32		
Gas setting .....	32		
<b>H</b>			
Handing over to the end user .....	36		
Heat exchanger, cleaning .....	38		
High-efficiency pump .....	35		
High-efficiency pump output .....	35		
<b>I</b>			
If you smell gas .....	4		
Ignition electrode, checking .....	38		
Inspection work .....	37		
Installation, preparations .....	22		
Intended use .....	4		
<b>K</b>			
Kammerbelüftung .....	15		
Kundendienst .....	7		
<b>L</b>			
Leak-tightness .....	33, 39, 43		
<b>M</b>			
Maintenance work .....	37		
Minimum clearance .....	15		
Mounting template .....	20		
<b>O</b>			
Overheating protection .....	13		
<b>P</b>			
Power supply .....	27		
Pressure sensor .....	42		
Product, draining .....	39		
Product, switching on .....	31		
Pump head .....	41		
<b>R</b>			
Regulations .....	6		
Removing the air intake pipe .....	37		
Removing the burner .....	37		
Removing the flue pipe .....	37		
Removing the front casing .....	21		
Removing the gas-air mixture unit .....	37		
Removing the ignition transformer .....	37		
Removing the side section .....	21		
Repair work, preparing .....	40		
Replacing the burner .....	40		
Replacing the expansion vessel .....	41		
Replacing the heat exchanger .....	40		
Replacing the main PCB .....	42		
Replacing the PCB for the user interface .....	42		
Replacing, expansion vessel .....	41		
<b>S</b>			
Safety devices .....	13		
Spare parts .....	37, 40		
Standards .....	6		
Switching on .....	31		
<b>T</b>			
Treating the heating water .....	29		
<b>U</b>			
Unpacking the product .....	14		
<b>V</b>			
Validity of the instructions .....	11		
Volume flow sensor .....	42		
<b>W</b>			
Wall-mounting the product .....	20		
Weight .....	20		





**Manufacturer/Supplier**

**Vaillant Group UK LTD**

Nottingham Road – Belper-Derbyshire – DE56 1JQ  
Telephone 01773 824639 – Technical helpline 0330 100 7679  
After sales service 0330 100 3142  
[www.glow-worm.co.uk](http://www.glow-worm.co.uk)



0020300875\_01

0020300875\_01 – 09.11.2020

© These instructions, or parts thereof, are protected by copyright and may be reproduced or distributed only with the manufacturer's written consent.  
Subject to technical modifications.