

Installation and Servicing Instructions

To be left with the user

Glow-worm 56/2 Back Boiler Unit

GC No 44 315 40

For use with specially designed Glow-worm fire fronts only

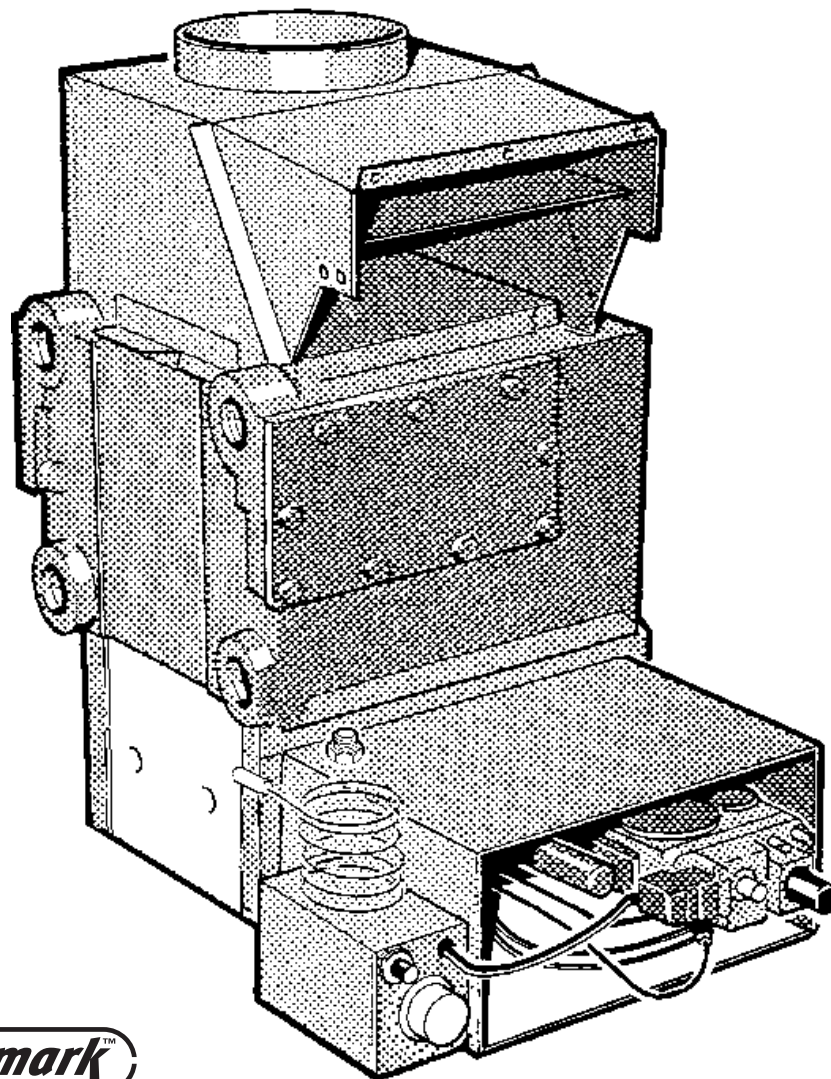

8010



References in these instructions to British Standards and Statutory Regulations/Requirements apply only to the United Kingdom. For Ireland the rules in force must be used.



BS 6332
BS 5258

This is a Cat I_{2H} Appliance

HEATCALL

Customer Services:

Tel: (01773) 828100

One Contact Local Service Fax: (01773) 828070

Hepworth Heating Ltd.,

Nottingham Road, Belper, Derbyshire. DE56 1JT

General/Sales enquiries:

Tel: (01773) 824141 Fax: (01773) 820569

1 General

6070

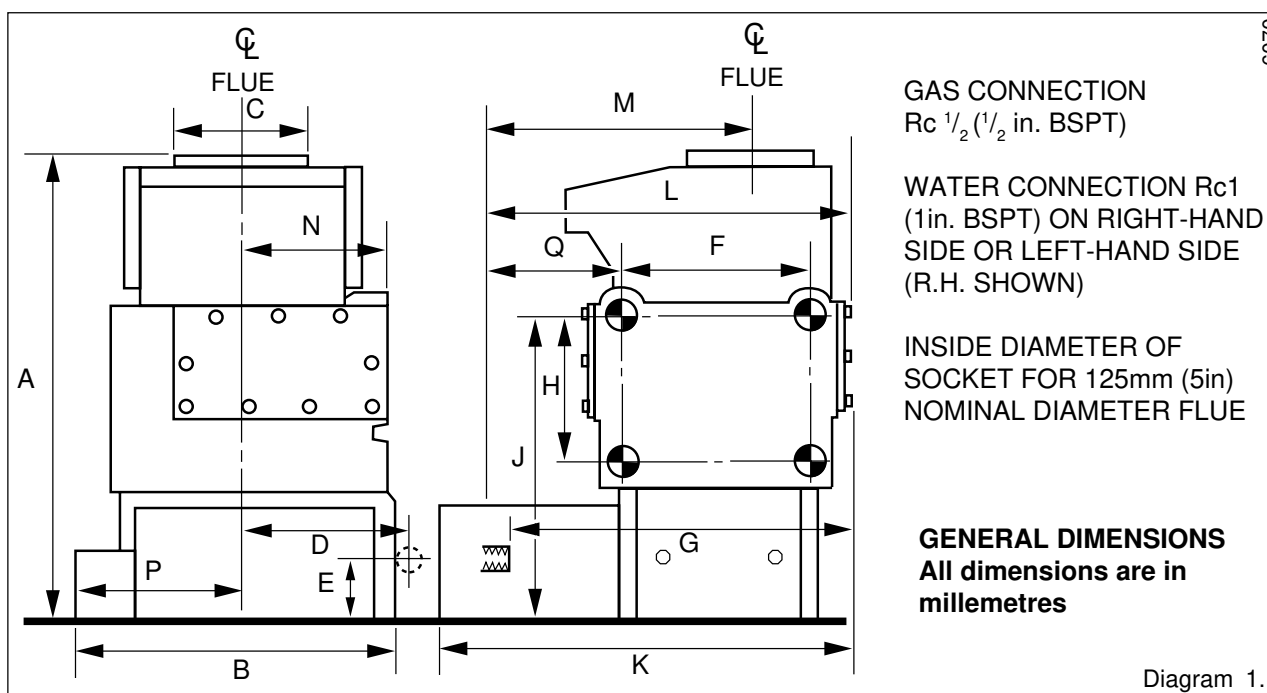

GAS CONNECTION
Rc 1/2 (1/2 in. BSPT)

WATER CONNECTION Rc1
(1 in. BSPT) ON RIGHT-HAND
SIDE OR LEFT-HAND SIDE
(R.H. SHOWN)

**INSIDE DIAMETER OF
SOCKET FOR 125mm (5in)
NOMINAL DIAMETER FLUE**

GENERAL DIMENSIONS
All dimensions are in
millimetres

Diagram 1.1

Dimension	A	B	C	D	E	F	G	H	J	K	L	M	N	P	Q
'56/2'											345min	238min			88min
BACK BOILER	547	357	146	185	56	212	382	168	350	460	370max	263max	154	192	113max

The instructions consist of three parts, Installation and Servicing Instructions for the Back Boiler Unit, Installation and Servicing Instructions for the Fire Front and Instructions for Use, which includes the Guarantee Registration Card. The instructions are an integral part of the appliance and must, to comply with the current issue of the Gas Safety (Installation and Use) Regulations, be handed to the user on completion of the installation.

This boiler is for use only with a specially designed Glow-worm Gas Fire Front, see Table 1.

The boiler is delivered in one pack which contains all the parts necessary for the installation.

If installing the back boiler unit and fire front at the same time please read both sets of instructions before starting.

1 General Notes and Information

IMPORTANT NOTICE

The back boiler is fitted with a safety device which will shut it down if there is a lack of oxygen. If the back boiler shuts down frequently for no apparent reason the first things to be checked are the chimney and air inlets into the room. Any problems found must be put right, by a competent person, before the back boiler is used again.

This back boiler is for use only on G20 gas.

Wherever possible, all materials, appliances and components to be used shall comply with the requirements of applicable British Standards.

Where no British Standard exists, materials and equipment should be fit for their purpose and of suitable quality and workmanship.

Sheet Metal Parts

WARNING. When installing or servicing this back boiler care should be taken when handling the edges of sheet metal parts to avoid any possibility of personal injury.

1.1 Statutory Requirements

The installation of this back boiler unit must be carried out by a competent person in accordance with the current issue and relevant requirements of:

Manufacturer's instructions, supplied.

The Gas Safety (Installation and Use) Regulations, The Building Regulations, The Building Standards (Scotland) Regulations (applicable in Scotland), Local Gas Undertaking, Byelaws of the Local Water Company, The Health and Safety at Work Act, Control of Substances Hazardous to Health, The Electricity at Work Regulations and any applicable local regulations.

Detailed recommendations are contained in the current issue of the following British Standards and Codes of Practice, BS6891, BS5449, BS5546, BS6700, BS5871, BS5440 Part 1 and 2, BS6798, BS1251, BS7478, BS7593, BS7671.

Manufacturer's notes must not be taken as overriding statutory requirements.

1.2 Data

Gas connection	Rc1/2 (1/2 in BSPT)
Water connection	Rc1 (1 in BSPT)
Electrical supply	230V~50Hz fused 3A
Weight, about	47.4kg (104.5lb)
Water content	6.28Litres (1.38gall)
Injector	3.7mm

Dimensions are given in millimetres (except as noted).

Data Label: Bottom left of control tray.

1 General

1.3 Gas Supply

The gas installation shall be in accordance with the current issue of BS6891.

The supply from the governed meter must be of adequate size to provide a steady inlet working pressure of 20mbar (8in wg) at the back boiler.

On completion test the gas installation using the pressure drop method and suitable leak detection fluid, purge in accordance with the current issue of BS6891.

1.4 Electrical Supply

WARNING. This back boiler must be earthed.

All system components shall be of an approved type and shall be connected in accordance with the current issue of BS7671 and any applicable local regulations.

Connection of the back boiler and system controls to the mains supply should be through a double pole isolating switch, fused 3A having a minimum contact separation of 3mm in both poles.

Alternatively, a fused 3A 3 pin plug and unswitched socket outlet to the current issue of BS1363 may be used.

Wiring to the back boiler must be PVC (85°C) insulated type to the current issue of BS6500 Table 16, not less than 0.75mm² (24/0.20mm).

1.5 Site Requirements

Refer to diagram 1.1 for dimensions appropriate to the back boiler.

For all types of installation a standard sized builder's opening is required, see diagram 1.2.

It is important that the opening is cleared of debris and mortar.

It is recommended that the access hole for pipework into the fireplace or builder's opening is either at the left hand or right hand side of the chimney breast. If access is required at both sides then it may be necessary to prepare some of the connections before fitting the back boiler into the builder's opening.

The prepared base for the back boiler must be level.

Refer to Table 2 for dimensions of fire front fixing wall face which must be true.

1.6 Water System - Open Vented

This back boiler can be used on an unrestricted open vented system with the water supply taken from a feed and expansion cistern, having a head between 1m (3ft3in) minimum and 27m (90ft) maximum.

Diagrammatic layouts of systems are shown in diagram 1.3 and 1.4.

1.7 Sealed Water System

A kit and instructions, part number 426520, is available to enable the back boiler to be used on a sealed water system.

Please give the serial number of the back boiler when ordering the kit.

RANGE RATING TABLE			
RANGE RATING	Minimum	Medium	Maximum
NOMINAL HEAT INPUT (GROSS) <i>kW</i>	18.5	20.2	21.9
<i>Btu/h</i>	63,200	69,000	74,800
NOMINAL HEAT OUTPUT <i>kW</i>	13.8	15.2	16.5
<i>Btu/h</i>	47,100	51,950	56,450
BURNER SETTING PRESSURE <i>mbar</i>	9.8	11.7	13.7
<i>in.w.g</i>	3.94	4.70	5.5
INJECTOR MARKING	3.7 203001		

Table 1	G.C No.	
FIRE TYPE	Teak	Mahogany
Miami 3 BBU	37-047-04A	37-047-07A
Melody 3 BBU	37-047-06A	
Black Ash 3	37-047-08	
Saxony 3	37-047-09	
Brown Ember 3	37-047-02	

Table 2	Dimensions for minimum flat area (no fixtures)		Dimensions for fixture or surround protection clearance	
	X	Y	X	Y
Miami 3 BBU	642	698	750	836
Melody 3 BBU	642	698	750	836
Black Ash 3	700	660	840	890
Brown Ember 3	795	707	905	892
Saxony 3	700	625	840	860

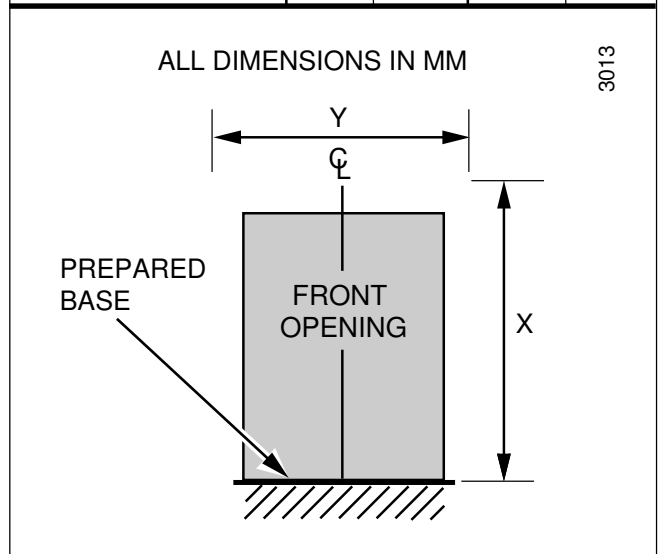

1 General

1.8 Hot Water Cylinder

The back boiler is suitable for open vented systems using an indirect cylinder (including single feed self priming type). The indirect cylinder must be fitted to the manufacturer's recommendations and the system must conform to the requirements of the current issue of BS5546 and BS6700.

It is recommended that the indirect cylinder be fitted with some form of temperature control.

1.9 Frost Protection

If the position of the back boiler is such that it may be vulnerable to freezing it should be protected as specified in the current issue of BS5422.

It is also recommended that a frost protection thermostat is fitted.

1.10 Draining Tap

A draining tap must be provided at the lowest point of the system which will allow the entire system, the back boiler and hot water cylinder to be drained.

Draining taps shall be to the current issue of BS2879.

1.11 Safety Valve

A safety valve need not be fitted to an open vented system.

1.12 Back Boiler Location

This back boiler MUST NOT be installed in a private garage or in a room containing a bath or shower or in a room used or intended to be used as sleeping accommodation.

1.13 BSI Certification

This appliance is certificated to the current issue of BS6332 Part 1 invoking the current issue of BS5258 Part 8 for safety and performance. It is, therefore, important that no alteration is made to it without permission, in writing, from Hepworth Heating Ltd.

Any alteration that is not approved by Hepworth Heating Ltd., could invalidate the BSI Certification of the boiler, warranty and could infringe the current issue of the Statutory Requirements.

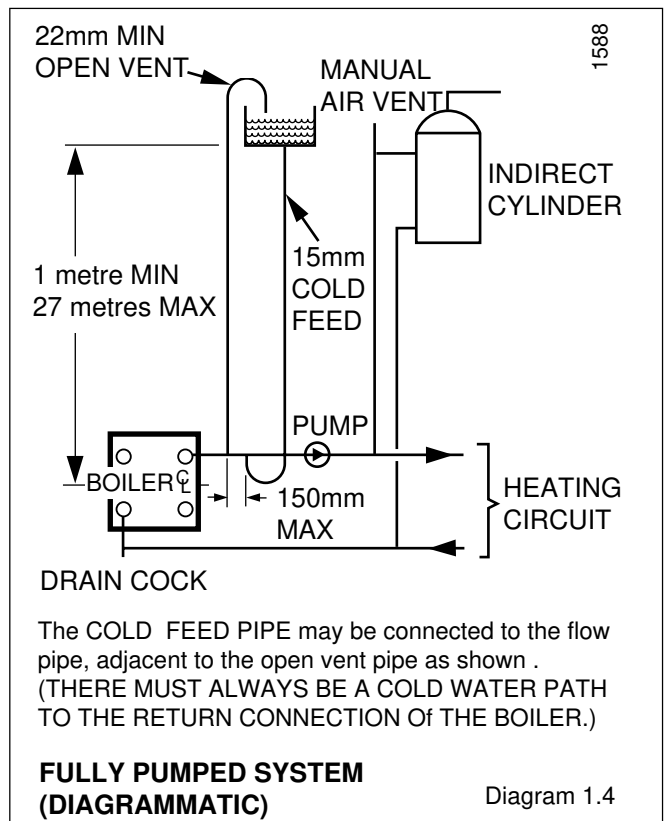
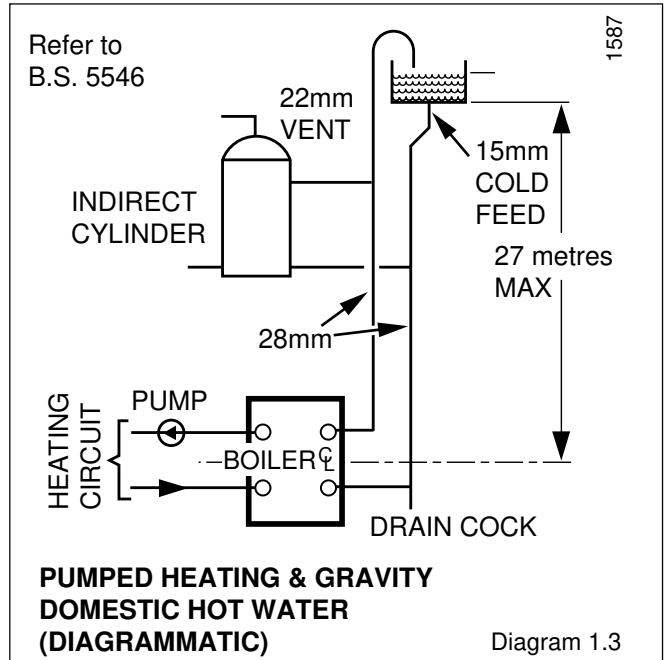
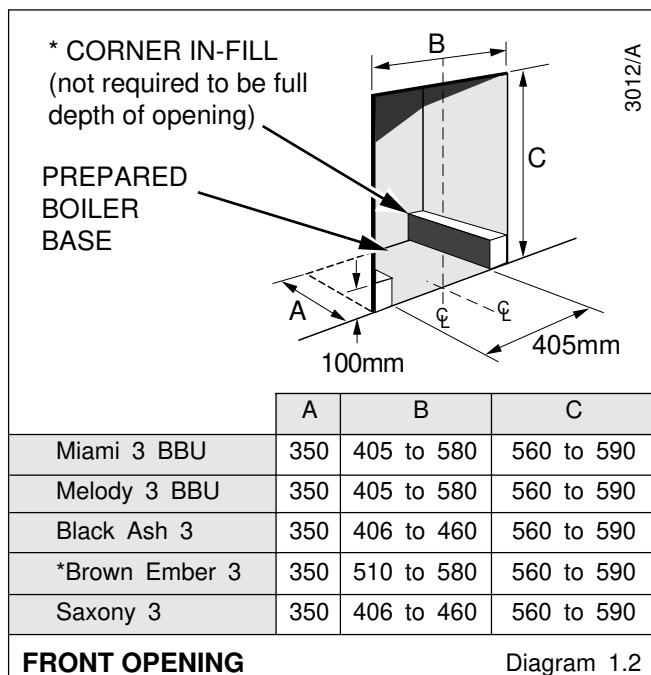

1 General

CE Mark

The CE mark on this appliance shows compliance with:

1. Directive 90/396/EEC on the approximation of the Laws of the Member States relating to appliances burning gaseous fuels.
2. Directive 73/23/EEC on the harmonization of the Laws of the Member States relating to electrical equipment designed for use within certain voltage limits.
3. Directive 89/336/EEC on the approximation of the Laws of the Member States relating to electromagnetic compatibility.

This boiler is exempt from the general requirements of the Boiler (Efficiency) Regulations (1993) and Directive 92/42/EEC by reason of its conformity to Schedule 3.1.7 of those Regulations and Article 4.3 of that Directive.

1.14 Inhibitor

Attention is drawn to the current issue of BS5499 and BS7593 on the use of inhibitors in central heating systems.

If an inhibitor is to be used, contact a manufacturer for their recommendations as to the best product to use.

If using in an existing system take special care to drain the entire system, including the radiators, then thoroughly cleaning out before fitting the boiler whether or not adding an inhibitor.

2 Types of Installation

2.1 With Non-combustible Hearth

The back boiler must be installed level with the hearth or above it, see diagram 2.1.

For minimum dimensions of a hearth see diagram 2.1.

2.2 Combustible Hearth

If the hearth is existing and made of a combustible material the back boiler must be installed to the dimensions in diagram 2.2.

2.3 With Surround

The combined thickness of the surround and lintel must be checked, to make sure that the back boiler can be positioned within the opening to allow easy connection of the flue into the back boiler flue socket, see diagram 2.3.

The surround requires a minimum opening for access as shown in diagram 1.2.

2.4 Wall Mounted - that is - Without Surround or Hearth

If there is to be any combustible material beneath the fire front, for example, carpet then the base of the builder's opening must not be less than 75mm above the floor covering as shown in diagram 2.2.

The builder's opening, with lintel must have minimum dimensions as shown in diagram 1.2 and 2.3.

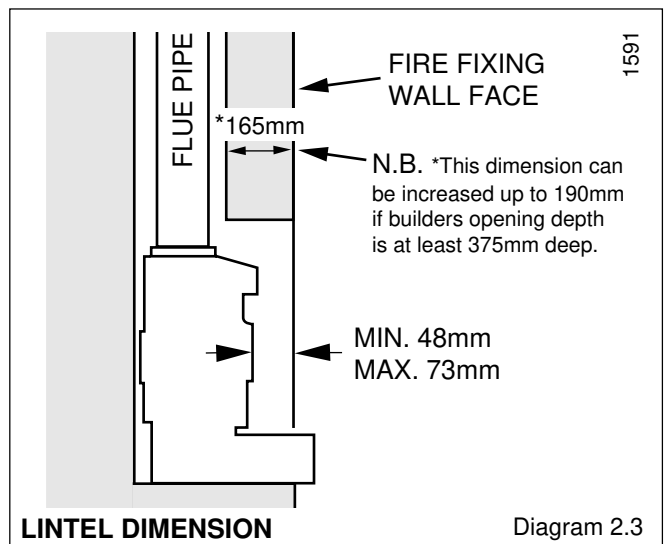
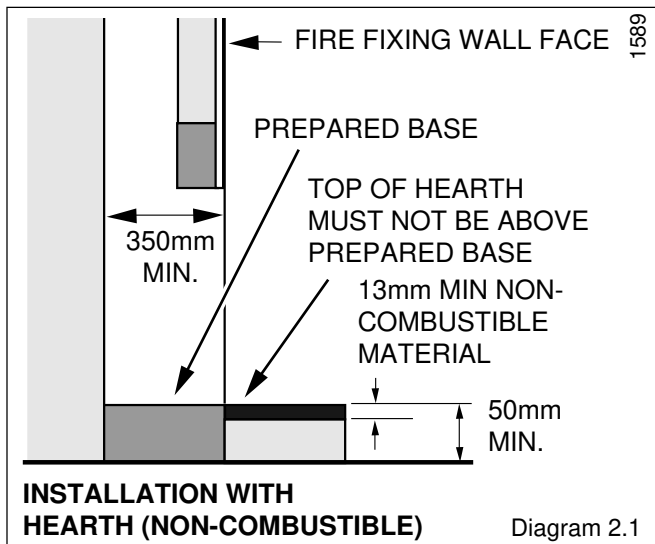
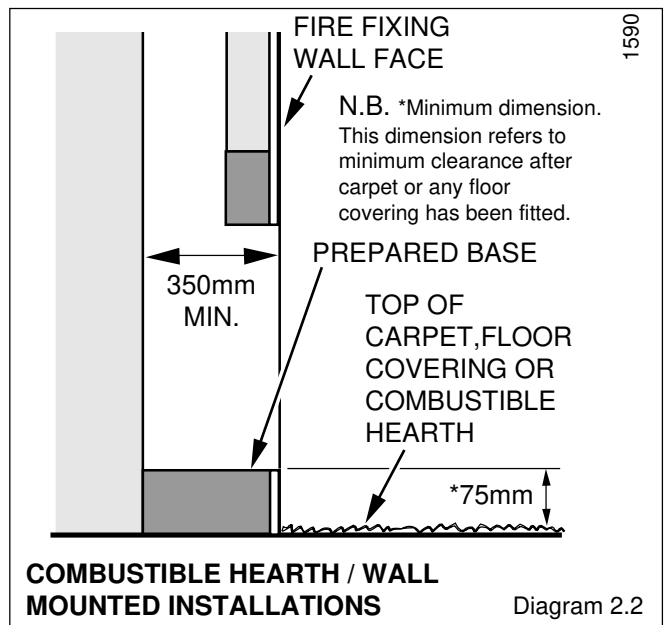

3 Flue and Ventilation

3.1 General

The general recommendations of the current issue of BS5440 Part 1 should be followed.

In all cases the flue should be lined, preferably with a flexible liner.

It is essential that the flue has an equivalent height of at least 2.5m (8.2ft) measured from the flue connection on the appliance. The first 600mm, at least, above the draught diverter must be vertical.

The flue socket is designed to take flue pipe to BS567. If flue pipe conforming to a different standard is used a suitable adapter must be fitted and secured to the flue socket. A flexible flue liner may be used, with connection to the back boiler flue socket made with a short vertical piece of flexible liner, see diagram 3.2.

The existing flue may not be completely sound. To prevent any possibility of leakage, additional sealing **MUST** be carried out between the base of the chimney and the flue liner.

The end of the liner at the chimney top must be adequately sealed and clamped, using proprietary fittings suitable for the flue liner used, see diagram 3.1.

The flue should, preferably, end above ridge height but at least above the eaves of a pitched roof. Use a certificated terminal.

If the flue is to pass through or near any combustible material it should be installed in accordance with the current issue of BS5440 Part 1. If in doubt seek advice from the local gas undertaking or Hepworth Heating Ltd.

3.2 Existing Chimney

An existing brick chimney must be thoroughly swept and all debris cleared away before lining.

Remove any register plates, dampers and the like. Alternatively it may be locked in the open position.

A flexible flue liner is preferred but a rigid liner may be used, with connection to the back boiler flue socket made with a short vertical piece of flexible liner, see diagram 3.2.

Any air supply that enters the builder's opening other than by the front opening, that is underdraught openings and the like must be completely sealed off.

The sealing plate also prevents debris falling and gives the flue better insulation, reducing the possibility of condensation, see diagram 3.1.

Check the flue system efficiency before installing the back boiler.

3.3 New Chimney

A newly built chimney can be lined with a moisture resistant lining, such as salt glazed pipe, of an appropriate diameter as specified in the Building Regulations

In the case of a salt glazed lined flue, it is recommended that a short vertical length of flue pipe, preferable flexible metallic be used, fixed and sealed to the back boiler flue socket, made good with approved packing and parged with fire cement, see diagram 3.2.

If a flue and false chimney breast are to be constructed all openings for pipework to upper floors etc., must be sealed. The only opening for the back boiler must be at the front, being of the dimensions as shown in diagram 1.2.

If a specially built compartment is constructed for the back boiler, it must conform to the requirements of the current issue of BS5440 Part 1 and BS5871.

The flue should, preferably, end above ridge height but at least above the eaves of a pitched roof. Use a certificated terminal.

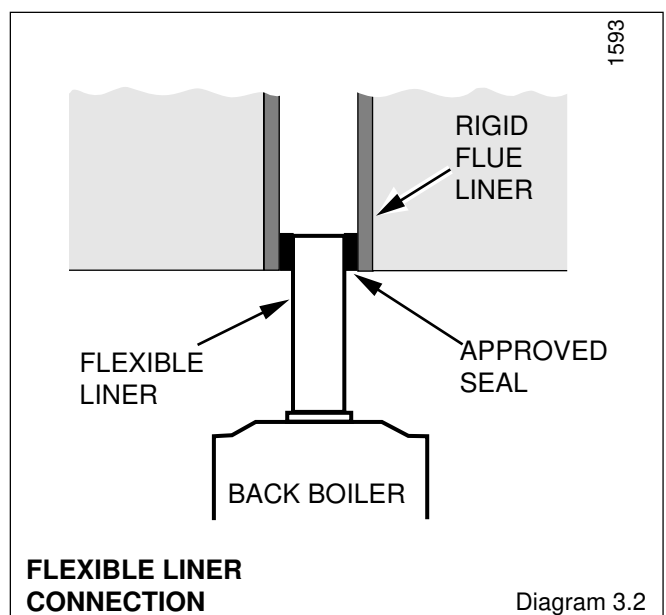
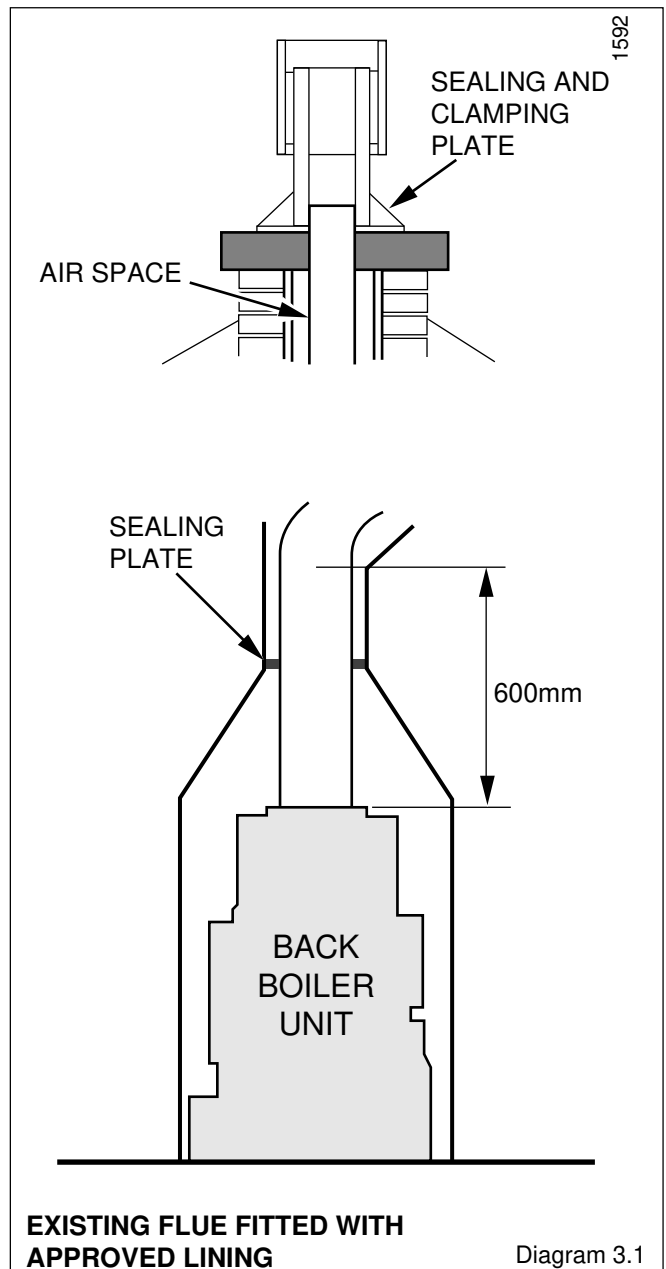

3 Flue and Ventilation

3.4 Ventilation - Back Boiler and Fire Front

It is important that the room in which the back boiler unit is installed has adequate air inlets to ensure correct operation as specified in the current issue of BS5440 Part 2.

Ventilation requirement for this back boiler is:

97cm² (15in²)

This ventilation area takes into account the total requirement of the back boiler unit and any of the specially designed gas fire fronts.

The ventilation openings may communicate direct with outside air or with an internal room or space (such as a hall) which itself is provided with a permanent air vent of the same effective area. The permanent air vent should be in a position which minimises nuisance to occupants due to draughts.

This vent must NOT be placed in the builder's opening.

If the appliance is to be installed in a room already containing another fuel burning unit, the air supply required for this other unit MUST be added to the figure above.

Any air vent taken through a cavity wall must be ducted.

3.5 Extract Fans

If an extract fan is fitted in the premises, there is a possibility that if adequate air inlet openings are not provided spillage of the products of combustion could occur.

When openings are fitted in accordance with the recommendations of the current issue of BS5440 Part 2, extract fans should not cause spillage.

Where such a fan installation is found, a clearance of products test must be conducted as described in the fire front Installation Instructions.

This test must be carried out with the back boiler fitted with its fire front.

See also Section 6.3 of these instructions.

4 Installation

4.1 Preparation

Remove draught diverter, flueway baffle and fittings pack from carton.

Remove back boiler body assembly from carton.

4.2 Water Connections

IT IS EXTREMELY IMPORTANT THAT NO SERVICE PIPES ARE ROUTED IN FRONT OF THE BACK BOILER.

If the builder's opening was previously used for solid fuel all pipework within should be protected with PVC tape or equal. Pipework passing through walls of the opening should be sleeved and made good.

The four heat exchanger connections are tapped Rc1 and are all on one side of the heat exchanger, see diagram 1.1.

4.3 Pumped Heating with Gravity Domestic Hot Water

All pipework must comply with the current issue of BS5546.

The domestic hot water flow and return pipes must be 28mm.

The domestic return must be into the connection directly below the domestic flow connection.

Refer to diagram 1.3 for a diagrammatic layout.

If it is necessary to route pipework from both sides of the builder's opening, it is recommended that the heat exchanger is positioned on the combustion chamber so that the gravity circuits exit on the same side as the back boiler connections.

It is recommended that pumped heating connections are prepped as in diagram 4.2.

If the heat exchanger connections are opposite hand to that required, the heat exchanger can be turned, as follows, remove the four screws securing the heat exchanger to combustion chamber, see diagram 4.1. Turn heat exchanger, refit the four screws.

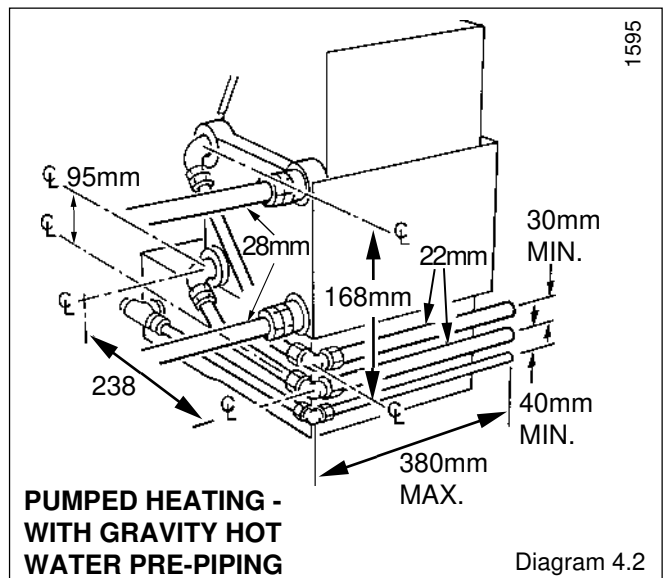
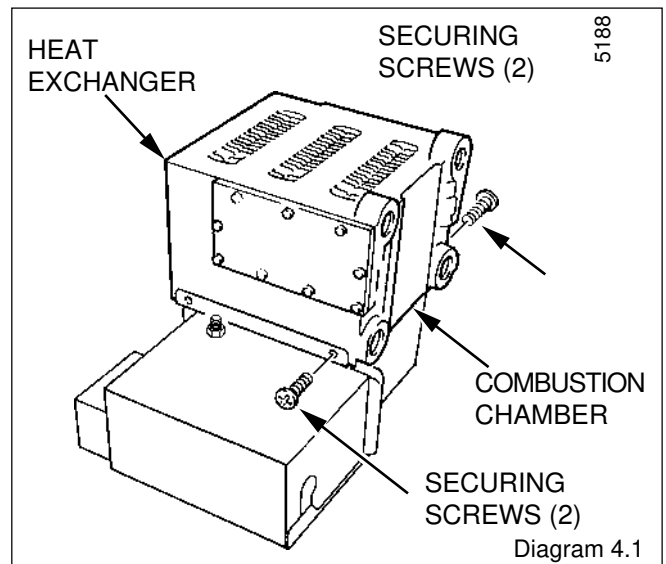

4 Installation

4.4 Pumped Heating and Hot Water

The pumped flow connection must be diametrically opposite to the pumped return connection.

Refer to diagram 1.4 for a diagrammatic layout.

If it is necessary to route pipework from both sides of the builder's opening it is recommended that the heat exchanger is positioned on the combustion chamber such that the flow pipe exits on the same side as the back boiler connections.

It is recommended that the pumped return is prepped as in diagram 4.3.

If the heat exchanger connections are opposite hand to that required, turn in the same manner as described in Section 4.3 paragraph 7.

4.5 Pump

Isolating valves, integral if possible, must be fitted each side of the pump.

4.6 Gas Supply

The gas installation must be fitted in accordance with the recommendations of the current issue of BS6891.

See diagram 1.1 for position of gas connection.

It is recommended that the gas supply enters the builder's opening on the right hand side.

If the gas supply enters from the left hand side it will be necessary to route the pipe behind the combustion chamber before final fixing, see diagram 4.2 and 4.3.

4.7 Positioning the Back Boiler

To position the back boiler lift by the casting and place centrally in the builder's opening. The installation centre line is marked on the combustion chamber extension and by a notch on the front edge of the floor protection plate.

The back boiler must be positioned so that a line across the opening of the fire fixing wall face falls between the appropriate front and rear limiting marks, see diagram 4.4.

The easiest method of aligning the back boiler is to use a straight edge across the top of the combustion chamber extension. It is important that the back boiler is square to the fire front fixing wall face.

Check that the back boiler is level. If packing is required to adjust the level of the back boiler, use metal shims and pack under the full width of the base.

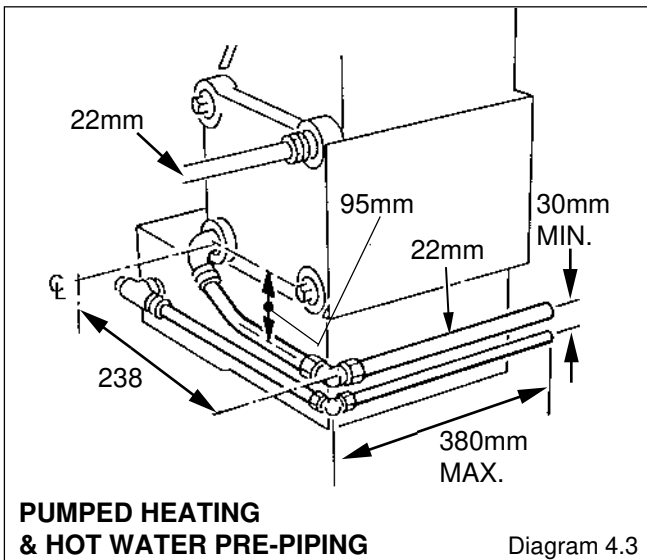

Mark through the fixing holes each side of the combustion chamber, see diagram 4.4. Remove the back boiler. Drill two holes to accept the plugs and fixings provided.

If access to the fixing holes shown in diagram 4.4 is difficult, use the alternative method described in Section 4.8 otherwise proceed as Section 4.9.

4.8 Alternative Back Boiler Fixing

Position the back boiler as described in Section 4.7 paragraphs 1 to 3.

Carefully disconnect the electrical plug from the gas valve and undo the four screws securing the combustion chamber extension and remove, see diagram 4.8.

Mark position of fixing holes on each side of the floor protection plate, see diagram 4.9. Remove back boiler from the opening. Drill two holes to accept the plugs and fixings provided.

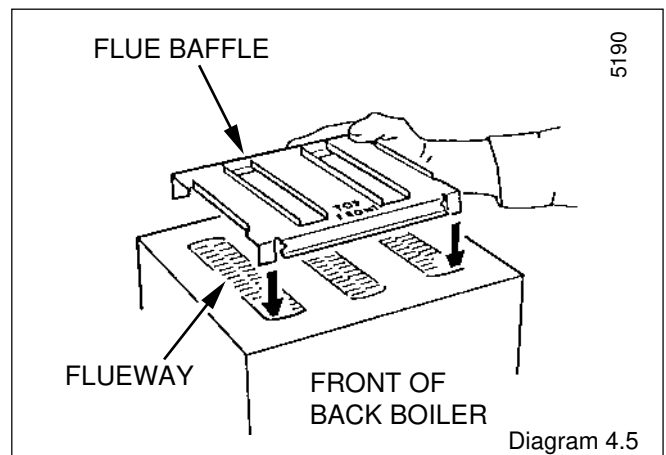
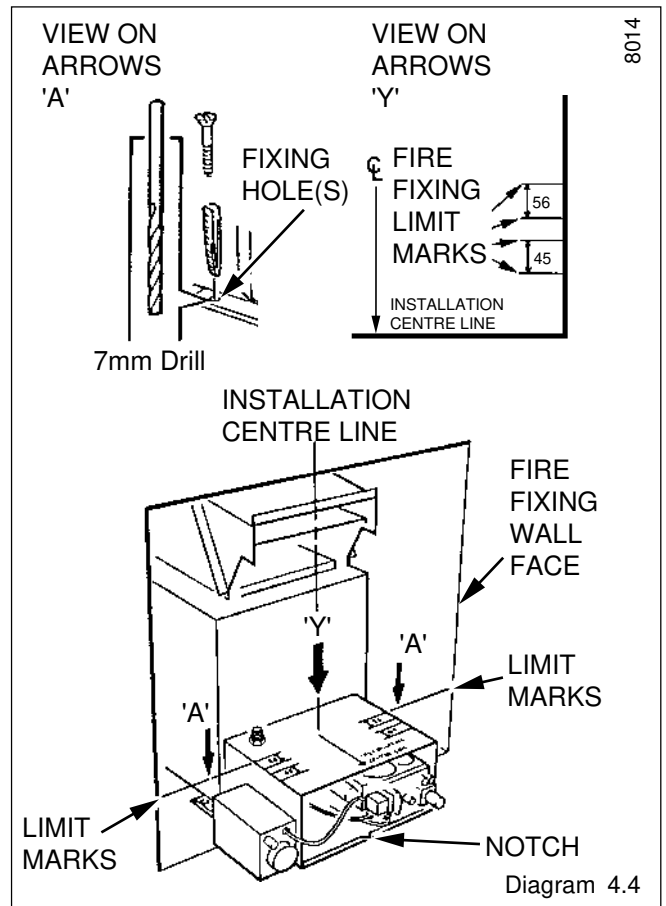

4 Installation

4.9 Positioning the Back Boiler - continued

Fit the flue baffle on top of the heat exchanger ensuring that the four corners are correctly located into the flueways, see diagram 4.5. The flue baffle is marked "TOP FRONT".

Fit the draught diverter onto the heat exchanger with the four screws provided in the fittings pack, see diagram 4.6. taking care not to damage the seal.

Where a flexible flue liner is being used, fully fit the No8x³/₈in self tapping screw provided into the rear of the flue socket as in diagram 4.7.

Reposition the back boiler into the builder's opening and secure to the prepared base with the screws provided. Connect the system pipework to the back boiler unit/preplumbed pipework. Refit the combustion chamber extension, if previously removed.

Connect gas supply to gas service cock. Leave gas service cock in the Back Boiler/Fire "OFF" position, see diagram 6.2.

If a flexible liner is being used, position the liner in to the flue socket. Using two No8x¹/₂in self tapping screws coloured black, screw through the two remaining holes in the flue socket to centralise and secure the flue liner, see diagram 4.7. Seal with a suitable fire clay cement.

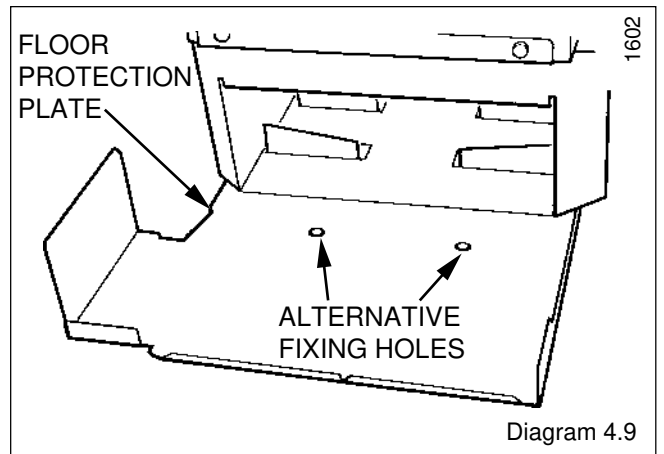
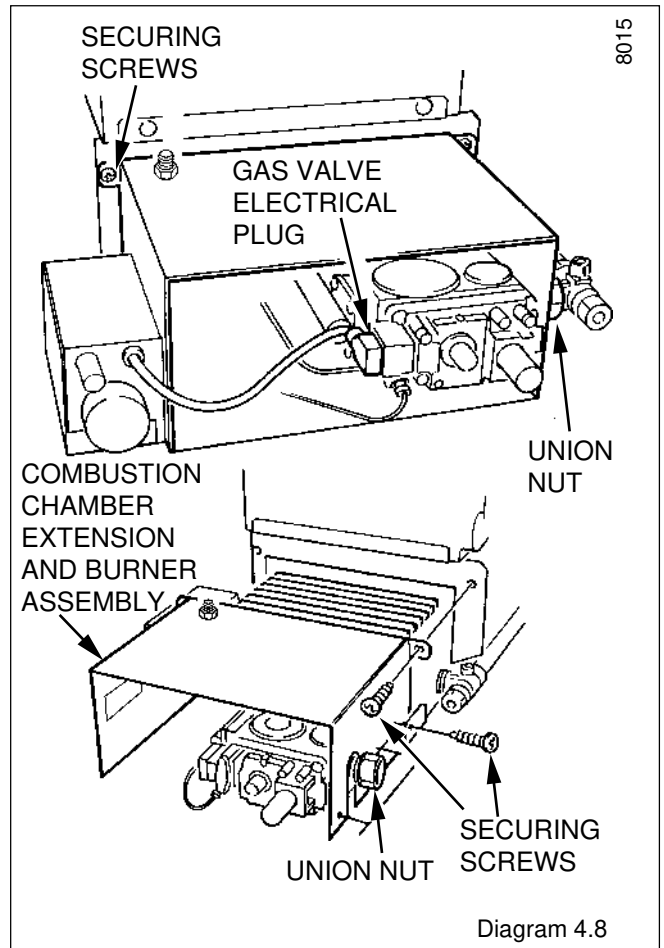
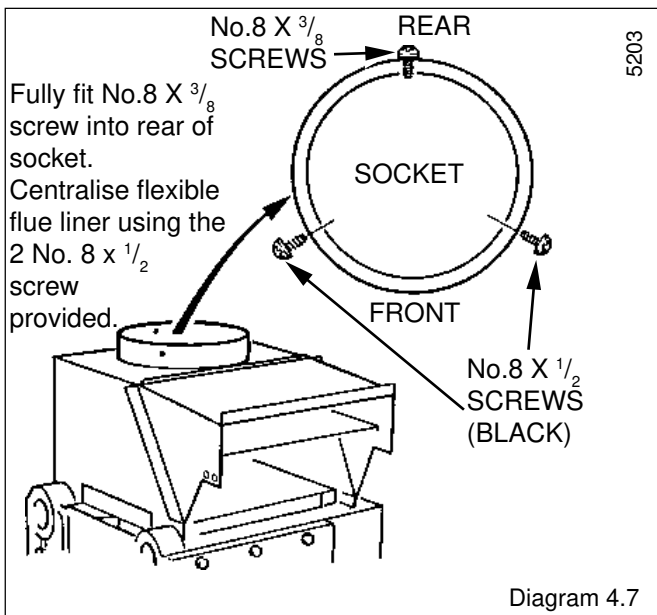
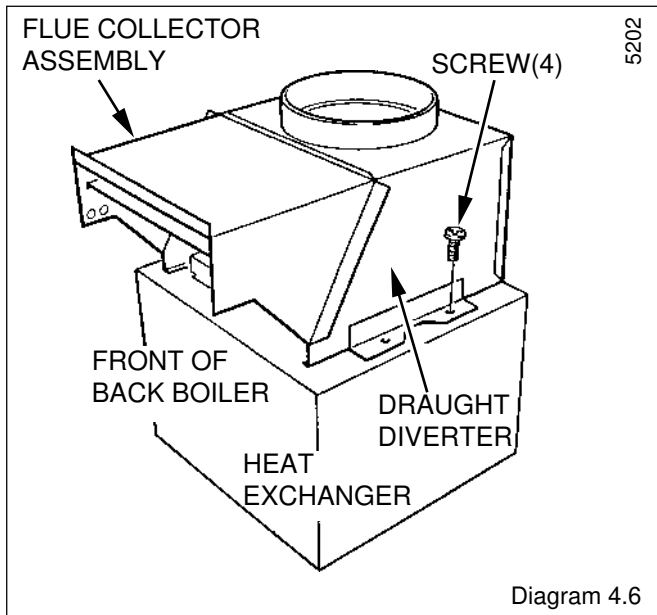

5 Electrical Wiring

5.1 General

WARNING. This boiler must be earthed.

ISOLATE THE ELECTRICAL SUPPLY BEFORE DOING ANY WIRING.

All of the electrical installation must be correctly earthed and be in accordance with the current issue of BS7671 and be carried out by a competent person.

The mains supply required is 230V~ 50Hz, fused at 3A. A double pole isolating switch, having a minimum contact separation of 3mm in both poles should be used.

The mains cable should be PVC heat resistant to 85°C the current issue of BS6500 Table 16, not less than 0.75mm² (24/0.20mm).

Make sure that there is sufficient cable slack to ease future servicing or replacement.

It is preferable to have the electrical supply cable coming from the left hand side of the builder's opening.

If however, it must come from the right hand side, it must be secured under the front edge of the combustion chamber extension using the two cable clips, from the fittings pack, as shown in diagram 5.1.

Make sure that all cables are routed well clear of hot surfaces.

5.2 Access to the Boiler Control Box

Disconnect the gas valve electrical plug, (if not already removed) see diagram 5.2.

Remove the electrical control box securing screw and lift the box upwards to release, see diagram 5.5.

5.3 Control Box Wiring

Thread the cable through the rear of the box, see diagram 5.3.

The mains cable outer insulation must not be cut back external to the clamp.

When making connections, make sure that the earth conductor is made of a greater length than the current carrying conductors, so that if the cable is strained the earth conductor would be the last to become disconnected.

Connect the incoming mains earth conductor to the \perp terminal on the terminal block, see diagram 5.3 and 5.4.

Connect the incoming mains neutral conductor to N and boiler control live to L_s.

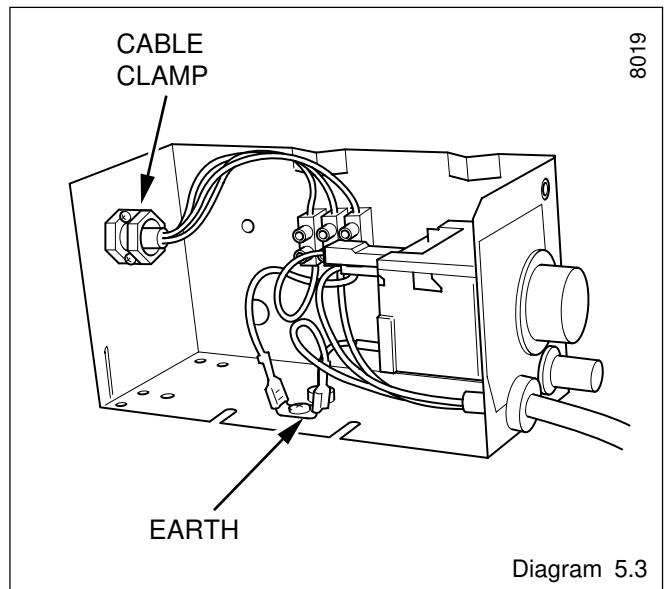
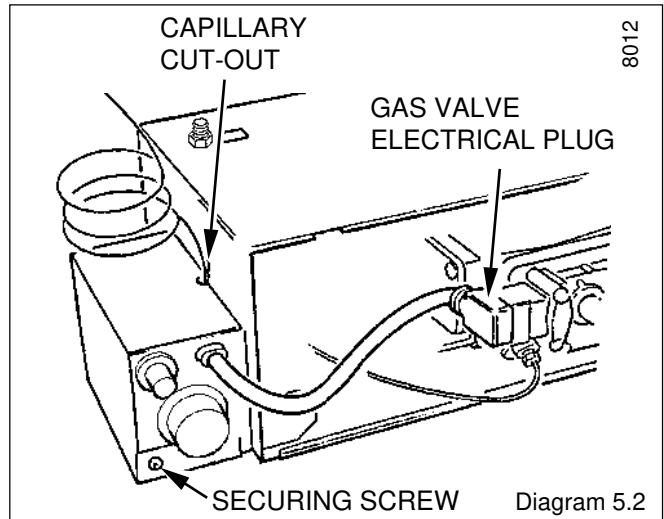
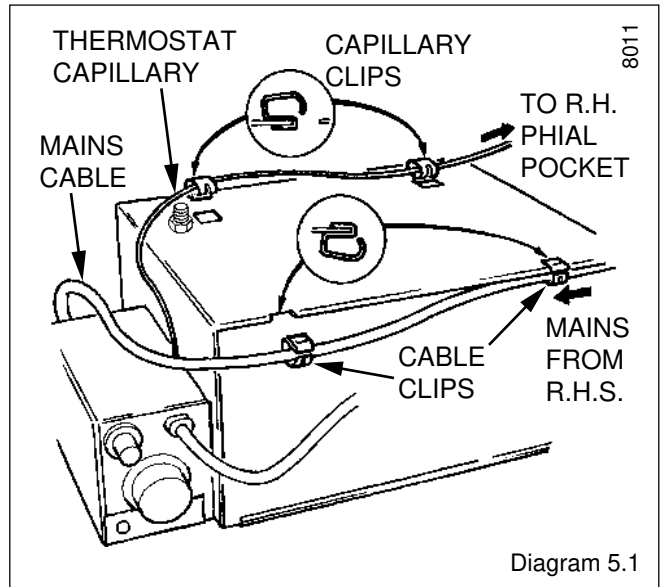

5 Electrical Wiring

8082

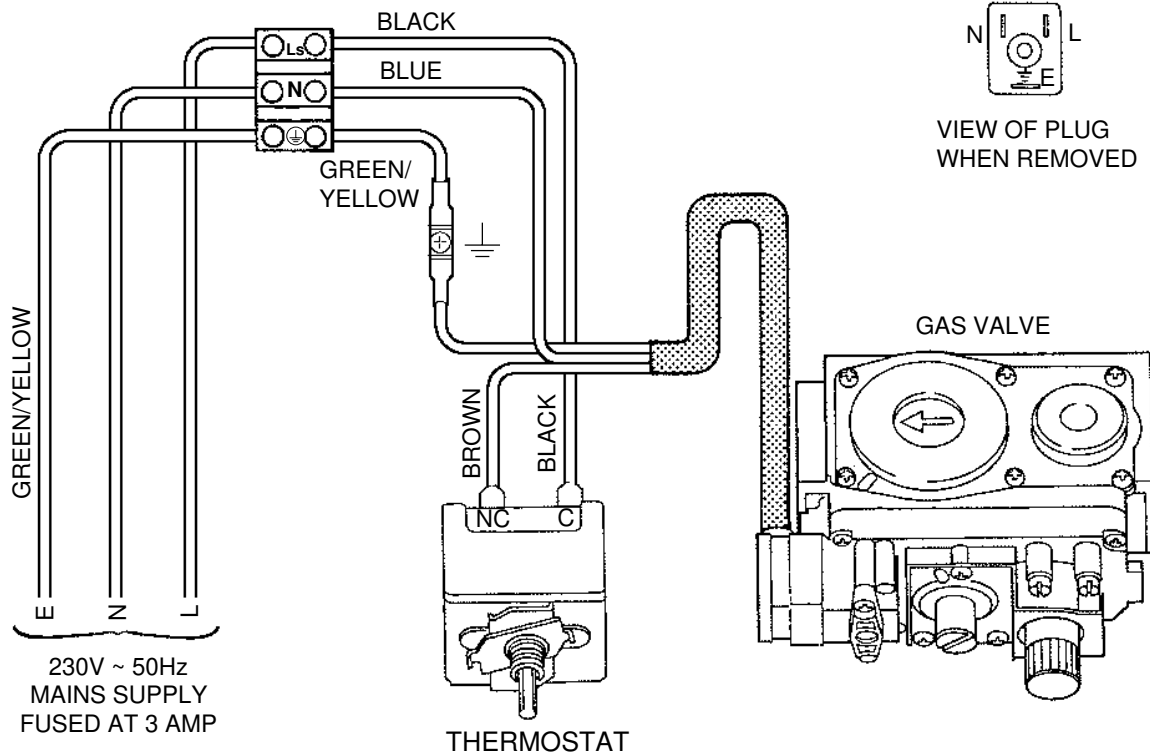

Diagram 5.4

5.4 Testing - Electrical

Checks to ensure electrical safety must be carried out by a competent person.

After installation of the system, preliminary electrical system checks as below should be carried out,

1. Test insulation resistance to earth of mains cable.
2. Test the earth continuity and short circuit of all cables.
3. Test the polarity of the mains.

5.5 Control Box Refitting

Refit the control box making sure that the control thermostat capillary is positioned so that it passes through the cutout in the control box panel, see diagram 5.2.

Secure with screw previously removed, see diagram 5.2.

Refit the gas valve electrical plug.

5.6 Control Thermostat Phial

Unwind the capillary so that it will be well clear of any part of the back boiler which becomes hot and insert it fully into the pocket, see diagram 5.6.

Secure with location washer behind the split pin.

If the phial pocket is on the right hand side use the cable clips supplied in the fittings pack. Secure the capillary, see diagram 5.1. Check that the capillary is not touching any hot surfaces.

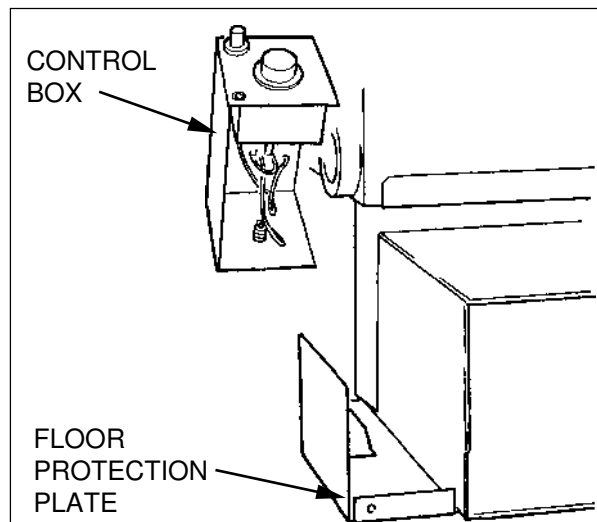

Diagram 5.5

8021

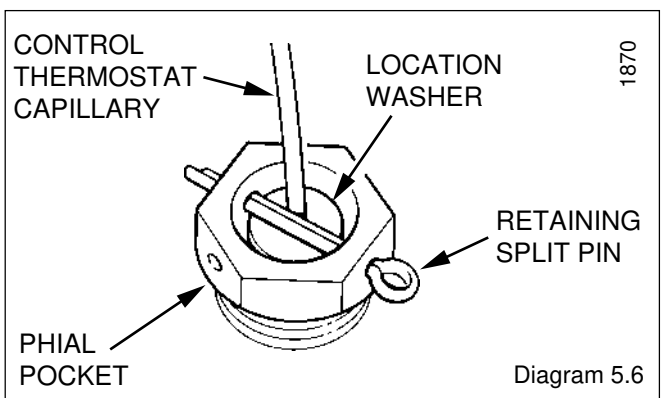

Diagram 5.6

1870

6 Commissioning

6.1 Commissioning the Back Boiler

The Back Boiler is fitted with a flue blockage safety device which will shut it down if there is a lack of oxygen.

The flue blockage safety device assembly incorporates the electrode, thermocouple and pilot assemblies.

Note: The flue blockage safety device sensing tube is supplied with the fire front.

The lighting, testing of the boiler and commissioning of the system can continue, but the lighting of the boiler must be repeated after fitting the sensing tube.

If the back boiler shuts down frequently for no apparent reason the first things to be checked are the chimney and air inlets into the room. Any problems found must be put right, by a competent person, before the back boiler is used again.

Also, when sensing tube is fitted, check that the filter is not linted up, see diagram 9.4.

The flue blockage safety device **MUST NOT** be adjusted or disconnected.

If replacing use only the correct and approved parts.

Before commissioning the back boiler, the whole of the system should be thoroughly flushed out with cold water with the circulation pump removed. Replace the pump, fill the system and examine for water soundness. Vent air from the system and pump.

CAUTION. The following work should be done by a competent person.

Identify the back boiler controls by reference to diagram 6.1.

Open windows and put out all naked lights, cigarettes etc.

Test the gas supply for soundness. Purge air in accordance with the current issue of BS6891.

Check that the electrical supply to the back boiler is switched off.

Set the control thermostat control knob "B" to "Off" that is, fully anti-clockwise.

Make sure the control thermostat phial is correctly located, see Section 5.6.

Remove the back boiler burner pressure test screw "G" and connect a suitable pressure gauge.

If flue blockage safety device sensing tube is not fitted, remove the plastic ferrule from the bulkhead connector on the air duct, replace ferrule after testing/commissioning.

Turn gas service cock "K" to Back Boiler only "On" position, see diagram 6.2.

Push in slightly and turn gas valve control knob "A" anti-clockwise until * is against the setting point, now fully push in and hold, at the same time press and release piezo button "D" until the pilot burner "E" lights, view through window "M".

Note, at this stage air may be present in the pilot supply so this operation may need to be repeated.

When the pilot burner lights, keep gas valve control knob "A" fully pushed in for about 15 seconds. If the pilot burner fails to stay alight, repeat the lighting procedure but now keep the control "A" knob pushed in for a little longer.

Check that the pilot flame is stable and has a length as shown in diagram 6.3.

Push in slightly and turn gas valve control knob "A" anti-clockwise until ♁ is against the setting point.

If the gas valve control knob "A" is turned until ● is against the setting point, a safety lock prevents it being turned on again until the thermocouple has cooled. **NO ATTEMPT SHOULD BE MADE TO TURN THE CONTROL KNOB "A" UNTIL AT LEAST 3 MINUTES HAVE GONE BY.**

Switch on electrical supply and set any remote controls that is, clock, thermostats, and the like, for heating. Refer to control manufacturers' instructions for specific detail

Turn control thermostat knob "B" clockwise until "MAX" is against the setting point. The main burner should now light.

Test for gas soundness using a suitable leak detection fluid.

The back boiler is supplied preset to the maximum heat input but may be adjusted to suit design requirements. Refer to Data Label or Range Rating Table for details.

If adjustment is required, TEN MINUTES after lighting, remove cover "F" and turn adjustment screw, anti-clockwise to suit system design heat input.

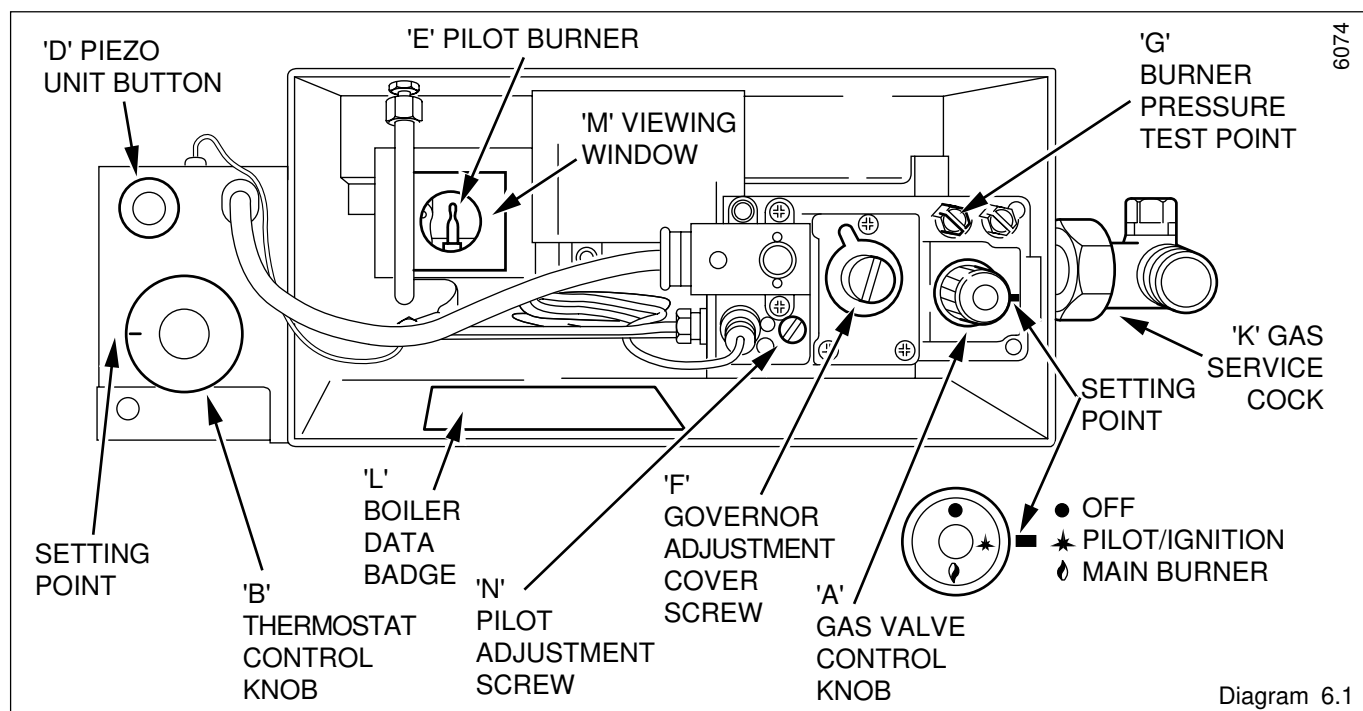

Diagram 6.1

6 Commissioning

Should any doubt exist, the gas rate should be checked at the gas meter.

The rate of the back boiler should be within the range,

1.64 m ³ /h to 2.15 m ³ /h
58.0 ft ³ /h to 76.0 ft ³ /h

Note, if the gas rate is checked, make sure that all other gas appliances and pilot lights are turned off.

Turn control thermostat knob "B" anti-clockwise to "O" "Off" position. Remove pressure gauge and replace test point screw make sure that a gas tight seal is made. Replace governor cover screw "F".

Relight the back boiler by turning control thermostat knob "B" clockwise to "MAX".

Use the self adhesive arrow from the fittings pack and stick it against the relevant heat input figure on the Data label.

6.2 Testing the Back Boiler Controls

To check the operation of the flame failure device carry on as follows:

With the main burner alight, slightly push in gas valve control knob "A" and then turn it fully clockwise until ● is against the setting point. This will cause the main and pilot burner to go out.

Note, relighting will not now be possible as the safety device in the gas valve has been activated.

Check that the flame failure device closes within 60 seconds, indicated by a "click" from the valve.

DO NOT ATTEMPT TO RELIGHT UNTIL AT LEAST 3 MINUTES HAVE GONE BY.

Relight the pilot and main burner as described in the relevant part of Section 6.1.

Check that the control thermostat and any external controls operate the back boiler correctly.

6.3 Clearance of Products

A clearance of products (spillage) test must be carried out after installation of the back boiler and its fire.

Before fitting the fire front check that the heat exchanger baffle is fitted and seated correctly.

Make sure that there is no flame disturbance on the back boiler burner immediately before carrying out test, look through pilot window "M", in diagram 6.1.

Details of the necessary procedure to be carried out will be found under "TEST FOR CLEARANCE OF PRODUCTS" in the fire front Installation Instruction Booklet.

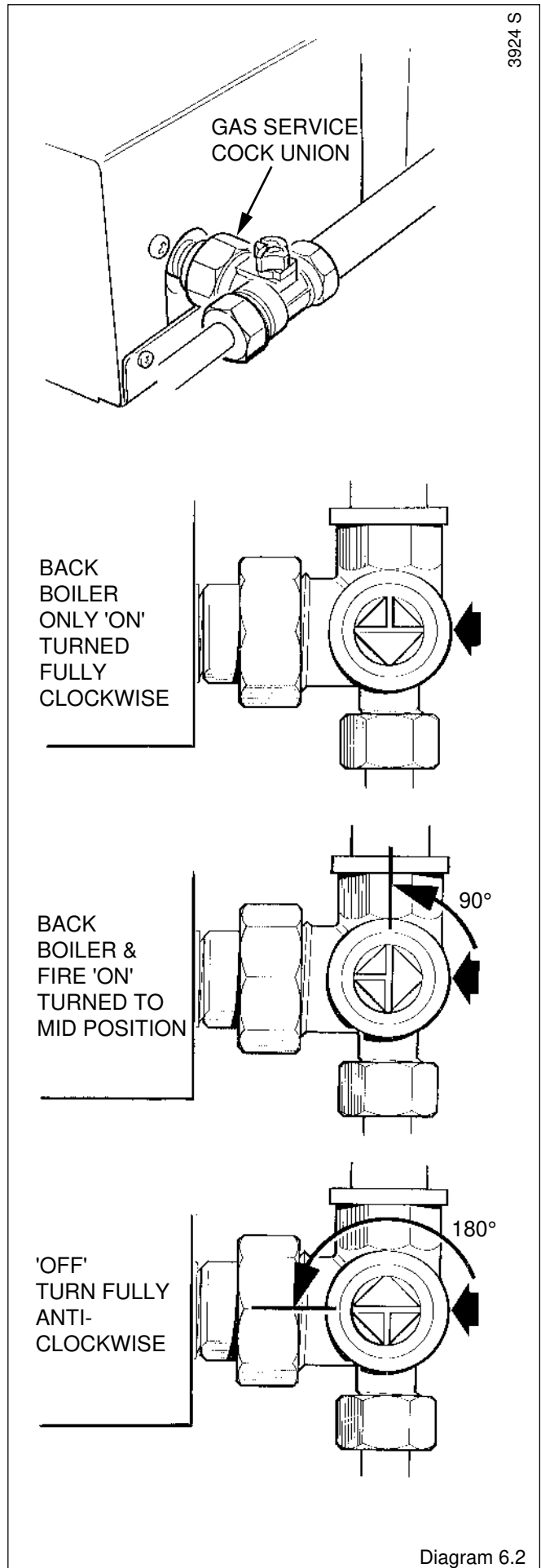

6 Commissioning

6.4 Commissioning the System

Set all controls to operate the heating system. Adjust pump and balance the system to give a temperature drop across the boiler of 11°C (20°F). At the appropriate flow rate, the resistance of the back boiler can be found by reference to diagram 6.4.

There should be no undue noise in the pipework or heat emitters. There must be NO pumping over of water or entry of air at the open vent pipe above the feed and expansion cistern.

Make sure that the back boiler control knob "B" is turned clockwise to "MAX" against the setting point, allow the water to reach maximum working temperature. Examine the system for water soundness.

Do not attempt to adjust the thermostat calibration screw.

Turn the control thermostat knob "B" anti-clockwise to "Off" and rapidly drain the system whilst still hot, to complete the flushing process.

Refill the system, vent and check again for water soundness.

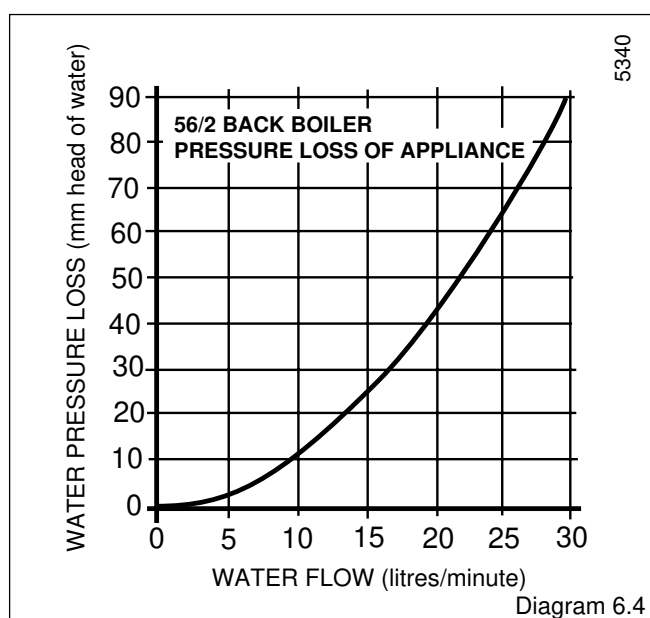
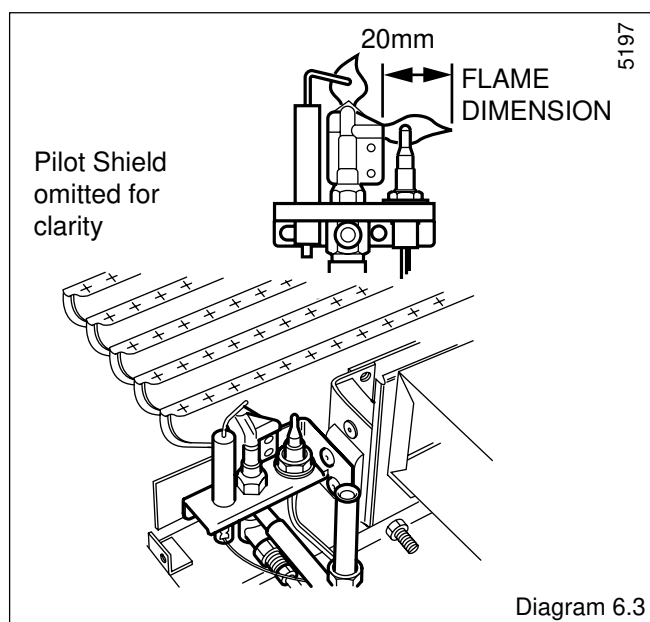

7 Fire Installation

Fire Front Installation and Servicing Instructions are packed with the fire front.

7.1 Completion - After Installation of the Fire Front

Instruct and demonstrate to the user, the efficient and safe operation of the back boiler, heating and hot water system and fire front.

Hand the Instructions for Use to the user, for their retention, making sure that they are understood.

Advise the user that to ensure the continued efficient and safe operation of the appliance it is recommended that it is checked and serviced as necessary at regular intervals. The frequency of the servicing will depend upon the particular installation conditions and usage, but in general once a year should be enough.

Draw attention, if applicable, to the current issue of the Gas Safety (Installation and Use) Regulations, Section, 35, which imposes a duty of care on all person who let out any property containing a gas appliance.

It is the Law that any servicing is carried out by a competent person.

Advise that the boiler is fitted with a safety device and refer to the instructions for use.

Set any remote controls for the system to settings requested by the user.

Advise the user of the precautions necessary to prevent damage to the system and building in the event of the heating system being out of use during frost and freezing conditions.

Reminder, leave these instructions with the user.

Advise the user that the 'Benchmark' logbook should be completed by the installation engineer on completion of commissioning or servicing.

8 Servicing

8.1 Servicing Notes.

(a) To ensure the continued efficient and safe operation of the appliance it is recommended that it is checked and serviced as necessary at regular intervals.

The frequency of the servicing will depend upon the particular installation conditions and usage, but in general once a year should be enough.

(b) It is the Law that servicing must be carried out by a competent person.

(c) Remove the fire front.

(d) Refer to the Gas Fire Front Installation and Servicing Instructions for full details of fire front removal.

(e) After completing any servicing always test for gas soundness with a suitable leak detection fluid and carry out functional check on controls.

(f) Unless stated otherwise reassembly of all components is in the reverse order to that for removal.

(g) The flue blockage safety device **MUST NOT** be adjusted or disconnected. If replacing use only the correct and approved parts.

8.2 Isolation of Services

Having removed the fire front.

Isolate the electrical supply to the back boiler.

Refer to diagram 6.1 to identify the controls.

Turn the gas valve control knob "A" to ● "Off" position and turn the appliance gas service cock to "Fire and Back Boiler Off", see diagram 6.2.

8.3 Controls Assembly and Burner.

Disconnect the union at the gas service cock, see diagram 6.2.

If necessary release the control thermostat capillary and the mains cable from the clips on the combustion chamber extension, see diagram 5.1.

Disconnect the electrical plug from the gas valve, see diagram 5.2.

Remove the control box securing screw and lift the box upwards to release, see diagram 5.2.

Disconnect the ignition lead from the piezo unit and remove from control box, see diagram 9.1.

Temporarily refit control box.

Note: On reconnecting the ignition lead to the piezo unit, it may necessary to temporarily remove the control thermostat, see Section 9.8. Ensure that the control thermostat capillary is replaced back in the cutout of the control box, see diagram 5.2.

Undo union nut and disconnect the back boiler lower sensing tube, undo the four combustion chamber extension securing screws and slide the extension/burner assembly forward to remove, see diagram 4.8.

Undo the two screws shown in diagram 8.1, which locate the burner support to the combustion chamber extension.

Turn the combustion chamber extension/burner assembly upside down.

Undo the lower sensing tube nut, see diagram 8.2.

Disconnect the ignition lead from the piezo unit.

Undo the two screws shown in diagram 8.2 which locate the gas valve control to the combustion chamber extension.

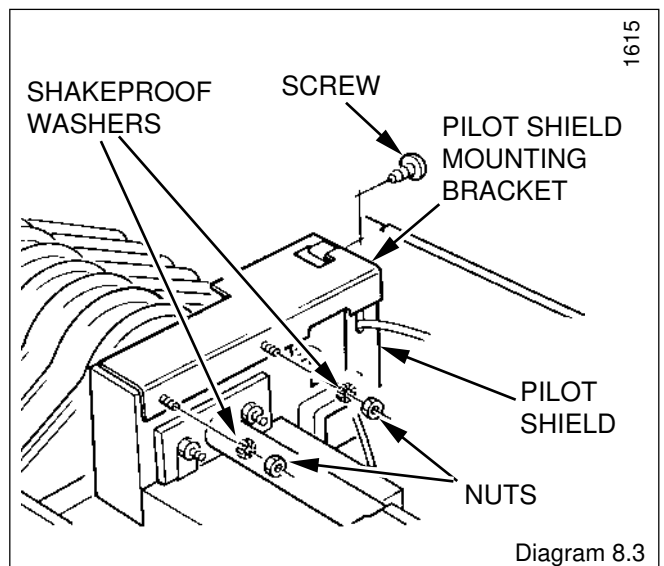
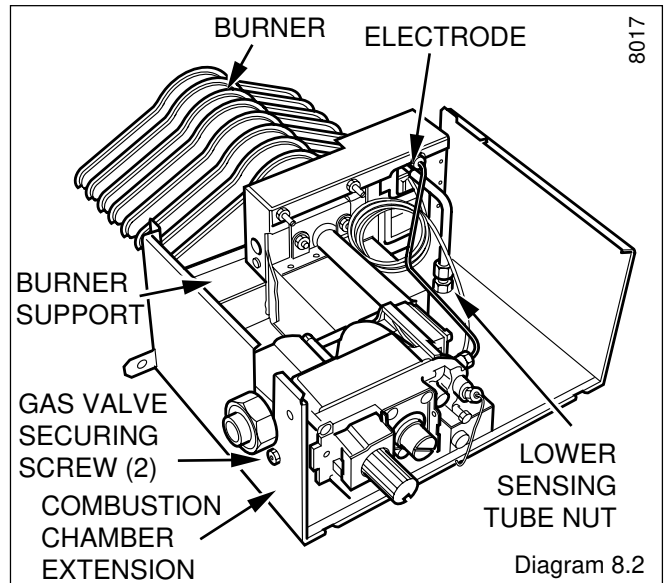
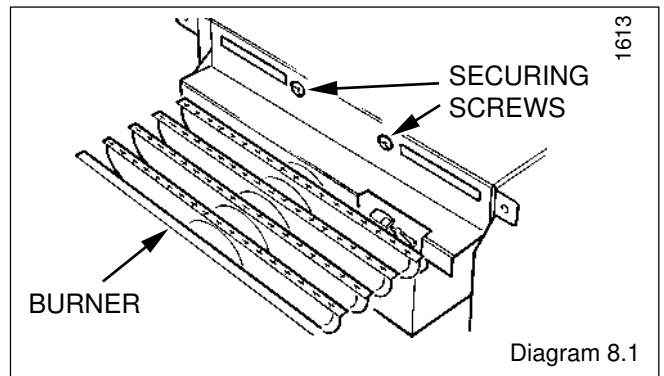

The complete gas carrying assembly can now be lifted clear of the combustion chamber extension.

Undo the screws on the side of the pilot shield, also the two nuts, also remove the two shakeproof washers securing the pilot shield mounting bracket to the burner, see diagram 8.3. Remove the pilot shield mounting bracket from the studs on the burner and remove the pilot shield.

Inspect the pilot for damage or blockage, clean or replace flue blockage safety device as necessary.

Make sure the spark gap is as diagram 8.4.

8 Servicing

Undo the two nuts shown in diagram 8.5 which secure the main gas manifold to the burner and remove the shakeproof washers, disengage the lint arrester and then withdraw the main gas manifold from the burner.

Clean the lint arrester as necessary.

Inspect the main burner injector for damage or blockage, clean or replace as necessary using a small amount of approved jointing compound, on the external thread.

Inspect the ignition lead for wear or damage, clean or replace as necessary, see diagram 8.4.

Inspect the thermocouple for wear or damage, clean or replace flue blockage safety device as necessary, see diagram 8.4.

Inspect the electrode for wear or damage, clean or replace flue blockage safety device as necessary, see diagram 8.4.

Inspect the flue blockage safety device sensing tube filter for damage or blockage, clean or replace as necessary, see diagram 9.4.

8.4 Refitting Burner Assembly

When refitting the lint arrester make sure that the lug is fitted into the slot on the burner support bracket, see diagram 8.5.

Position the pilot shield around the pilot tube, ignition lead and thermocouple before replacing the pilot shield mounting bracket, see diagram 8.3.

Loosely replace the gas valve control securing screws, see diagram 8.2. Refit the two screws shown in diagram 8.1, which locate the burner support to the combustion chamber extension. Refit the lower sensing tube nut into the bulkhead connection. Then fully tighten the gas valve securing screws.

Before replacing the burner and controls assembly into the back boiler the following servicing should be carried out.

8.5 Cleaning Back Boiler Flueways

Remove the burner assembly as Section 8.3.

Undo the two screws securing the fire front sensing tube, if fitted, and remove, see diagram 8.6.

Undo the two steel screws securing the flue collector assembly, see diagram 8.7 and remove the flue collector assembly.

Undo the two stainless steel screws securing the diverter plate, see diagram 8.8 and remove the diverter plate by sliding it forward.

Lift out the flue baffle, see diagram 8.9.

Clean the back boiler flue ways with a suitable stiff brush.

Note. A sheet of paper placed in the back boiler combustion chamber will help in collecting any debris.

To make sure that the flueways are clean, view with the aid of a mirror or reflector.

8.6 Refitting Flue Collector Assembly and Final Reassembly

When refitting the flue baffle make sure that the four corner lugs fit correctly into the back boiler flueways, see diagram 8.9.

When refitting the diverter plate make sure that the plate is correctly fitted into the guide channels as shown in diagram 8.8 and replace the two stainless steel securing screws.

Refit the flue collector assembly and if fitted the fire front sensing tube. Refit the burner and controls assembly to the back boiler.

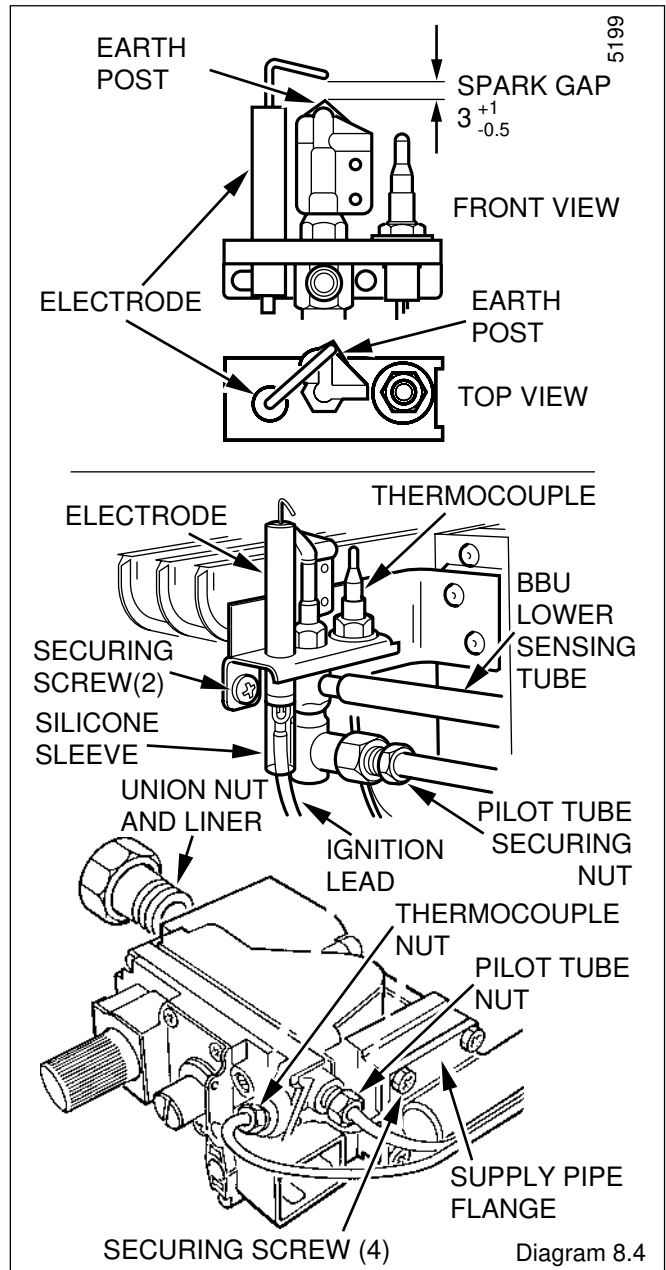

Diagram 8.4

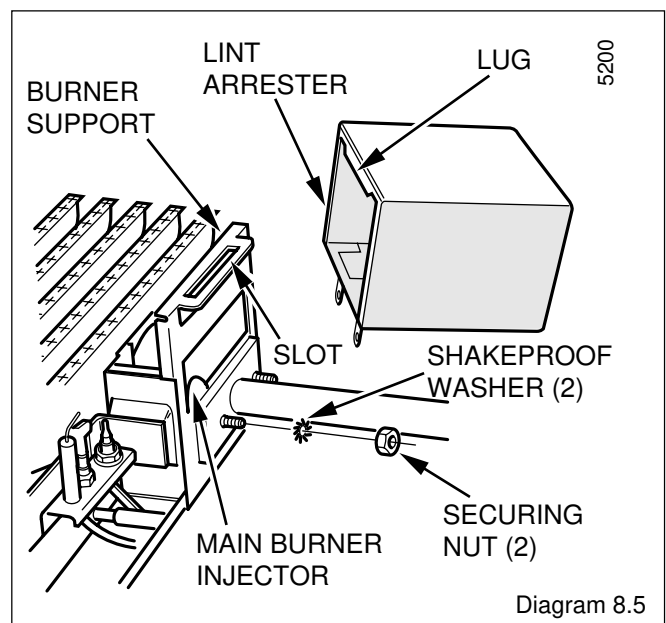
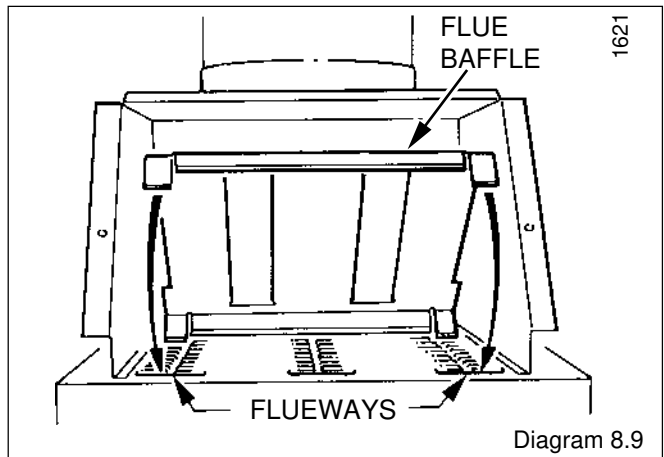
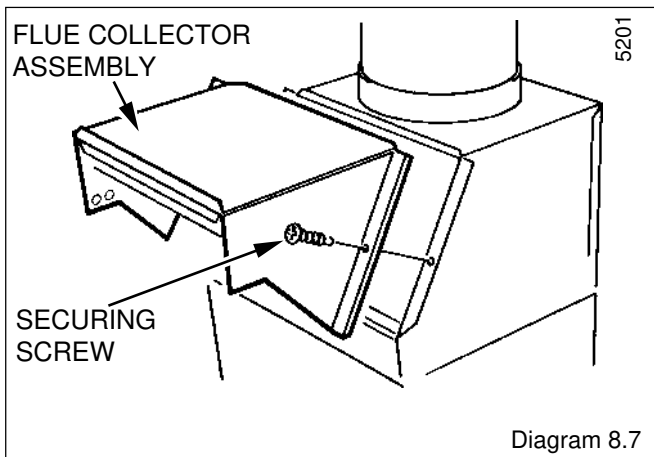
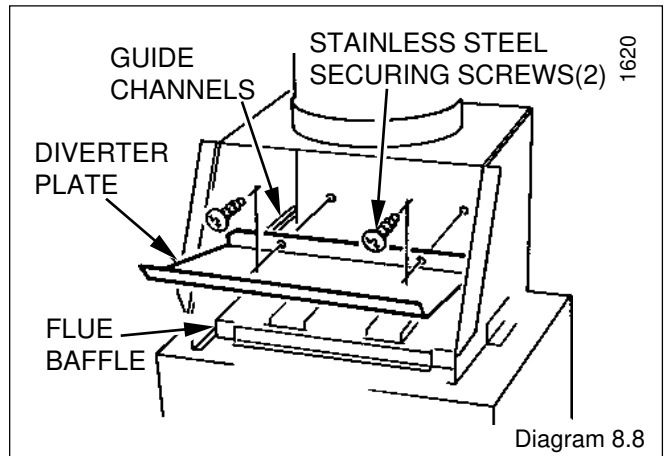
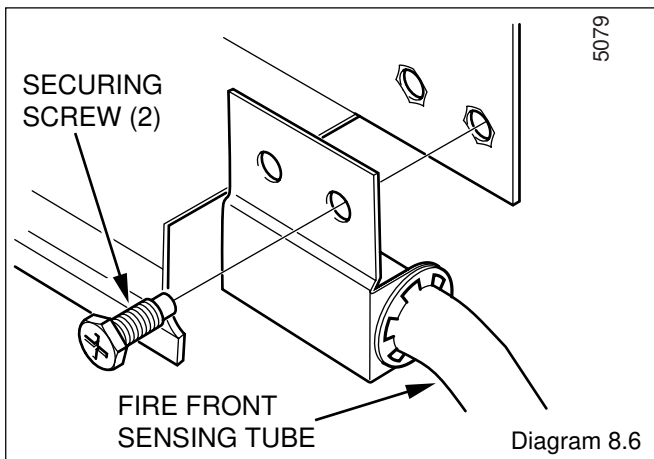

Diagram 8.5

8 Servicing



9 Replacement of Parts

9.1 Notes on Replacing Parts.

- Replacement of parts must be carried out by a competent person.
- Unless stated otherwise all parts are replaced in the reverse order to that of removal.
- After replacing any gas carrying parts always test for gas soundness using a suitable leak detection fluid. Also carry out functional check of controls.
- Refer to the Gas Fire Front Installation Instructions for details of the removal of the fire front.
- Isolate the electrical supply to the back boiler.
- Remove the gas fire front plinth.
- Refer to diagram 6.1 to identify the back boiler controls.

Turn the gas valve control knob "A" clockwise to ● "Off" position. Turn the appliance gas service cock anticlockwise to "Off" position, see diagram 6.2.

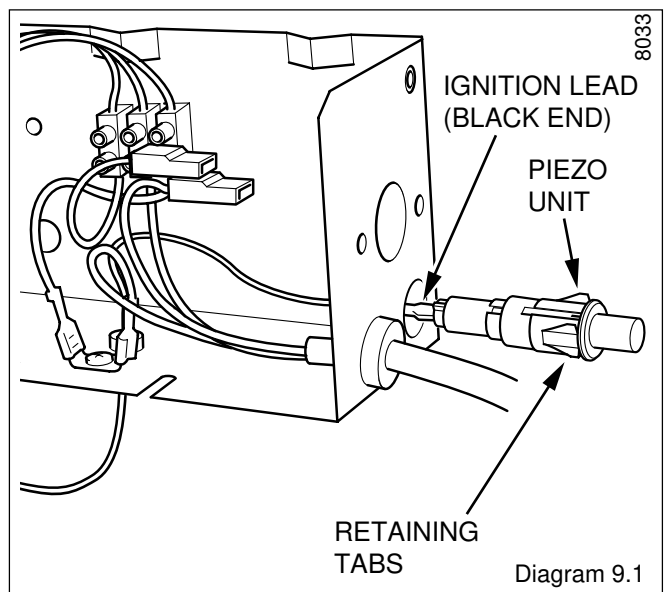

9 Replacement of Parts

9.2 Flue Blockage Safety Device Assembly

Gain access as the relevant part of Section 8.3.

Remove lead from electrode.

Pull off back boiler lower sensing tube.

Undo the pilot tube securing nuts and the thermocouple nuts at gas valve, see diagram 8.4.

Undo the flue blockage safety device assembly securing screws and withdraw, see diagram 8.4.

When refitting take care not to damage the lower sensing tube adapter "O" rings.

9.3 Gas Valve

Gain access as the relevant part of Section 8.3.

Disconnect the thermocouple tube nut at the gas valve and ease out of the valve, see diagram 8.4.

Disconnect the pilot tube nut at the gas valve.

Undo the securing screws to separate the gas valve from the supply pipe flange. Take care not to damage the "O" ring seal between the flanges.

Undo the two securing screws to release gas valve from the combustion chamber extension, see diagram 8.2.

Transfer the union nut and liner to the replacement gas valve using a small amount of approved jointing compound on the external thread only.

When fitting the thermocouple only tighten the nut at the gas valve a quarter turn beyond finger tight.

9.4 Ignition Lead

Gain access as the relevant parts of Section 8.3.

Remove the lead from the electrode and piezo unit.

Fit the silicone sleeve over the new lead.

Fit the black insulated end of the ignition lead to the piezo unit and the clear end to the electrode.

Push the silicone sleeve into position, see diagram 8.4.

9.5 Main Burner Injector

Gain access as the relevant parts of Section 8.3.

Refer to diagram 8.4 and undo the thermocouple nut and withdraw the thermocouple.

Undo the pilot tube nut at the gas valve control.

Refer to Section 8.3 paragraph eleven.

When replacing the main burner injector use a small amount of approved jointing compound on the external thread only.

9.6 Pilot Burner Injector

Should pilot burner injector need replacing, the whole pilot burner assembly must be replaced.

9.7 Piezo Unit

Gain access as the relevant parts of Section 8.3.

Disconnect the ignition lead from the piezo unit, see diagram 9.1.

Note: To ease the removal of the piezo unit it is advisable to temporarily remove the boiler thermostat from the control box, refer to Section 9.8.

Depress the retaining tabs and remove the Piezo unit.

NOTE: It is important that the thermostat is fitted the same way as shown in diagram

8019

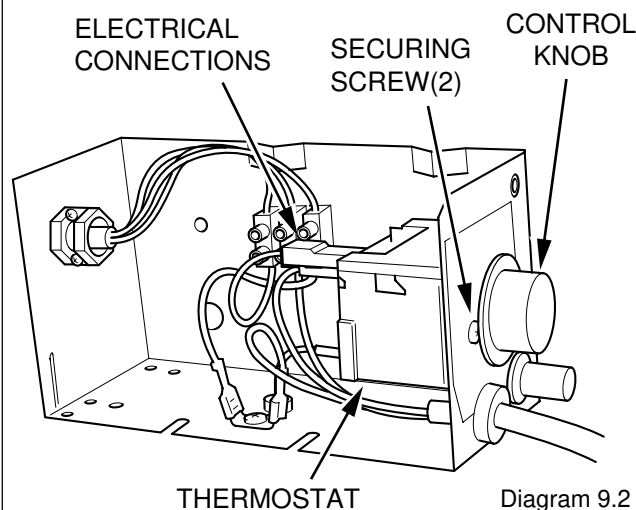
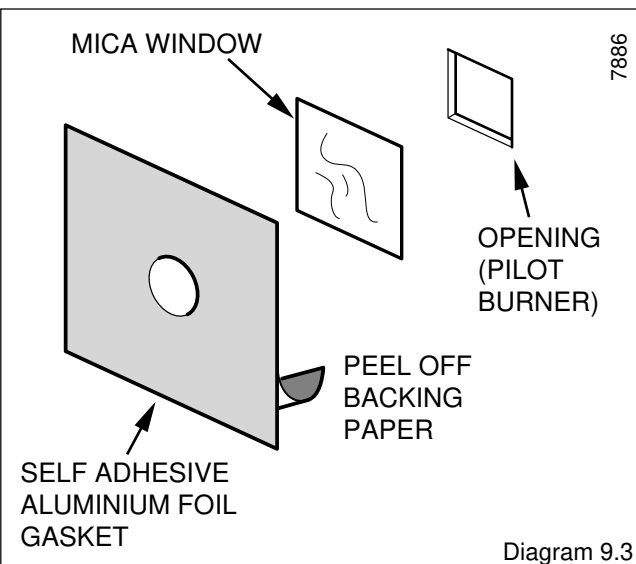
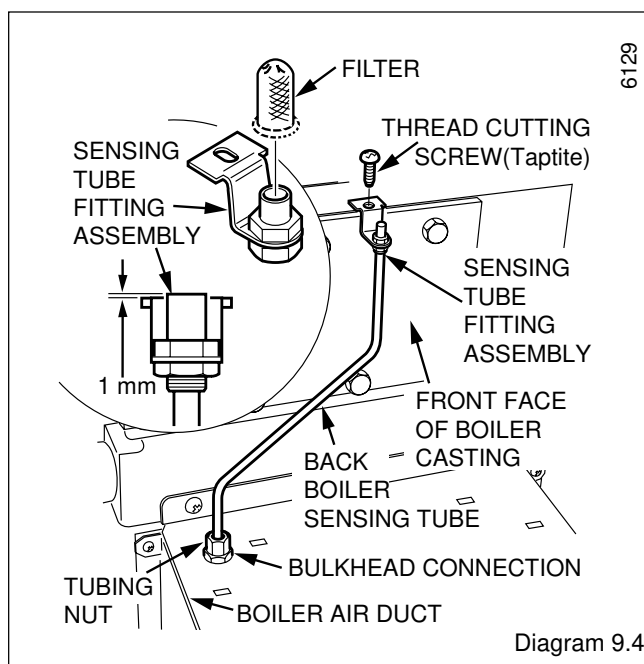

Diagram 9.2



7886

Diagram 9.3



6129

Diagram 9.4

9 Replacement of Parts

9.8 Control Thermostat

Disconnect the gas valve electrical plug, see diagram 5.2.

Remove the split pin to release the control thermostat phial, see diagram 5.6.

If the phial pocket and/or the electrical supply is on the right hand side, release the capillary and/or the main lead from the clips, see diagram 5.1.

Remove the control box securing screw and lift the box upwards to release, see diagram 5.2.

Remove the control thermostat knob "B", see diagram 9.2.

Remove the two securing screws and remove the control thermostat body.

When fitting the new control thermostat, make sure that the capillary connection to the control thermostat body is placed at the top of the control box top.

Refit electrical connections.

Capillary should pass through the cut out on the control box top, see diagram 5.3. Care should be taken to make sure that the side plate hooks onto the box before fitting the securing screw.

9.9 Viewing Window

Gain access as the relevant parts of Section 8.3.

Remove the old self adhesive aluminium foil gasket and the old mica window. Replace with a new mica window. Peel off the backing paper and secure with new self adhesive aluminium foil gasket, see diagram 9.3. Ensure no air bubbles are trapped underneath the foil.

Important

Make sure that the mica window fully covers the opening and that the hole in the aluminium foil gasket is centred over opening.

9.10 Flue Blockage Safety Device Sensing Tube Fitting

Remove filter, unscrew thread cutting screw and remove sensing tube fitting assembly, see diagram 9.4.

When fitting new filter, take care not to damage the filter.

10 Fault Finding

10.1 Electrical

Carryout the preliminary electrical system checks as contained in a multimeter instruction book.

Refer to functional flow wiring diagram 10.1 and electrical fault finding chart, diagram 10.2.

On completion of the fault finding task which has required the breaking and remaking of electrical connections the checks earth continuity, polarity and resistance to earth must be repeated.

10.2 Thermocouple

To test the thermocouple, a meter with a range of 0 - 30mV is required together with a thermocouple interrupter test unit.

Refer to thermocouple fault finding chart, diagram 10.3 and diagnosis graph, diagram 10.4.

10.3 Back Boiler Pilot and Ignition

To check back boiler pilot and ignition, refer to pilot fault finding chart, diagram 10.5.

10.4 Flue Blockage Safety Device

If the device operates and the filter is clean, it indicates there is a problem with the chimney. Make sure air vents are free from obstruction, carry out spillage checks as Fire Front Installation Instructions and put right as necessary.

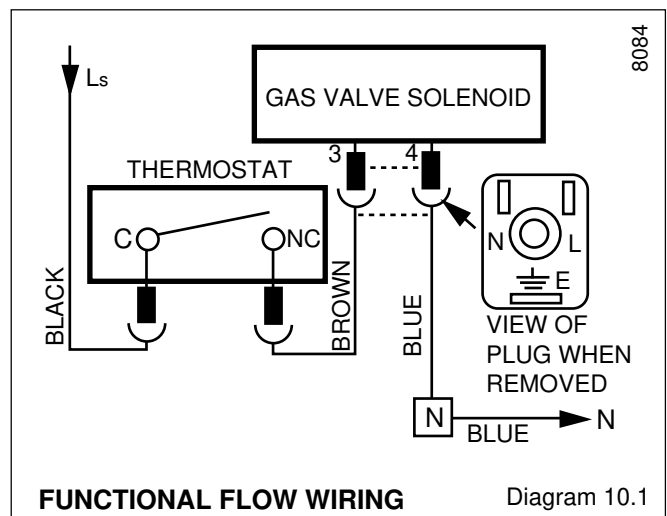

10 Fault Finding

Isolate power supply to the control box. Gain access to the control box and physically check all wires and connections. Check fuses. Check Flue Blockage Safety Device filter is not blocked, clear if necessary. Check that all remote controls, (eg room and / or cylinder thermostats), are making contact for duty.

4484A

Turn on the power supply to the control box. Turn on the boiler thermostat and measure the voltage between C and N.

Is the voltage between 216 and 264 volts.
 YES → [Next Step]
 NO → Check control box wiring and mains supply

Is there voltage between NC and N. 216 and 264 volts.
 YES → [Next Step]
 NO → Isolate the power supply. Replace thermostat

Isolate the power supply to the control box. Remove plug from gas valve and connect voltmeter between L and N in plug, ensuring no short circuits (mains voltage). Turn on power supply and measure voltage.

Is the voltage between 216 and 264 volts.
 YES → [Next Step]
 NO → Check control box wiring.

Isolate the power supply to the control box. Reconnect gas valve. Turn on power supply. Does main burner light.
 YES → [Next Step]
 NO → Isolate power supply. Replace gas valve.

Turn off boiler thermostat, measure voltage across 3 and 4. Is the voltage zero.
 YES → [Next Step]
 NO → Isolate power supply. Replace thermostat.

Does the main burner extinguish.
 YES → [Next Step]
 NO → Isolate power supply. Replace gas valve.

Boiler electrical system operating satisfactorily

ELECTRICAL FAULT FINDING CHART

Diagram 10.2

10 Fault Finding

6131

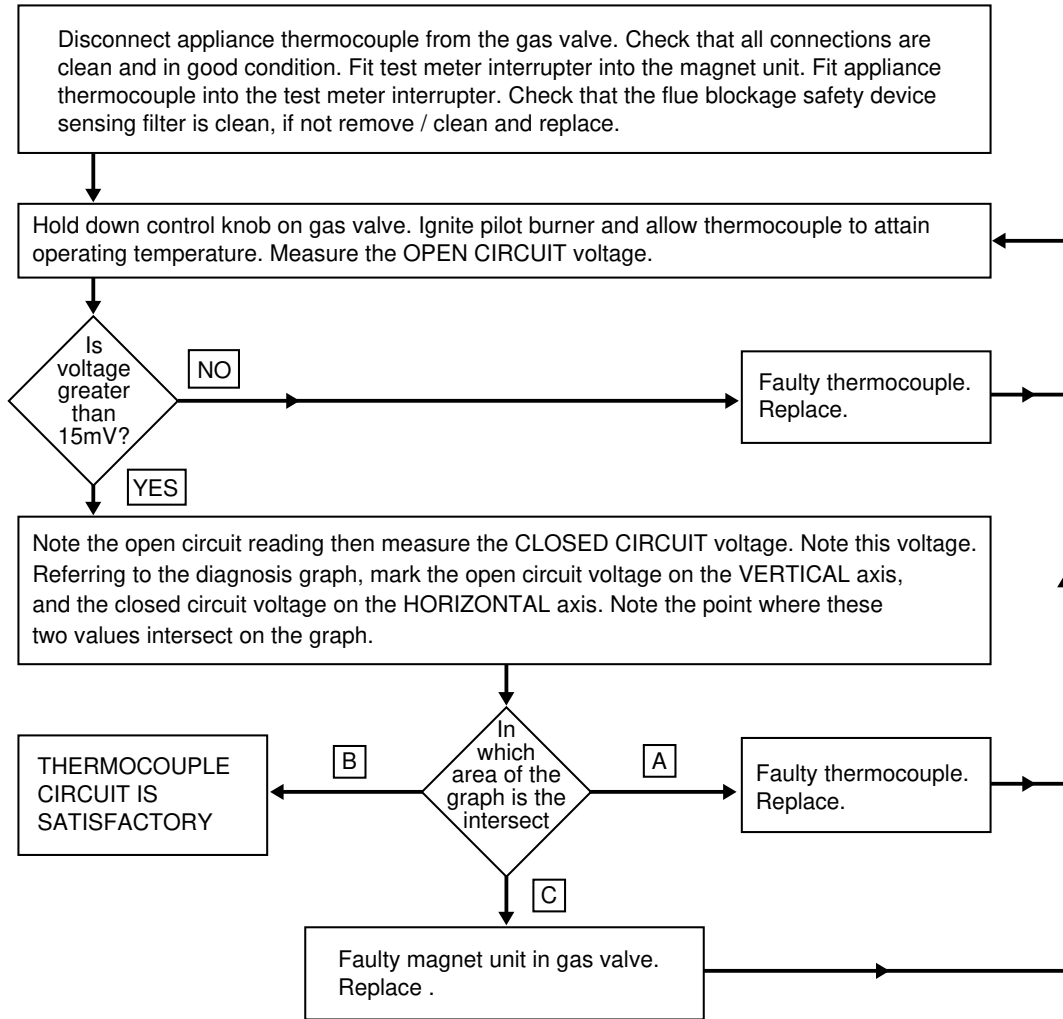

**THERMOCOUPLE
FAULT FINDING CHART**

Diagram 10.3

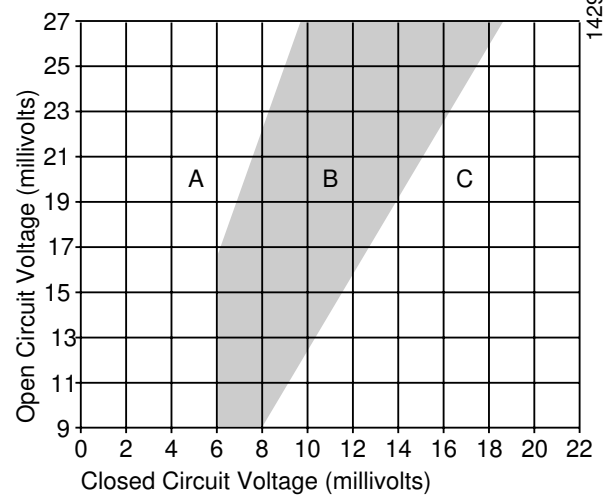

**DIAGNOSIS GRAPH FOR BOILER
THERMOCOUPLE CIRCUIT**

Diagram 10.4

**PILOT WILL NOT LIGHT
START HERE**

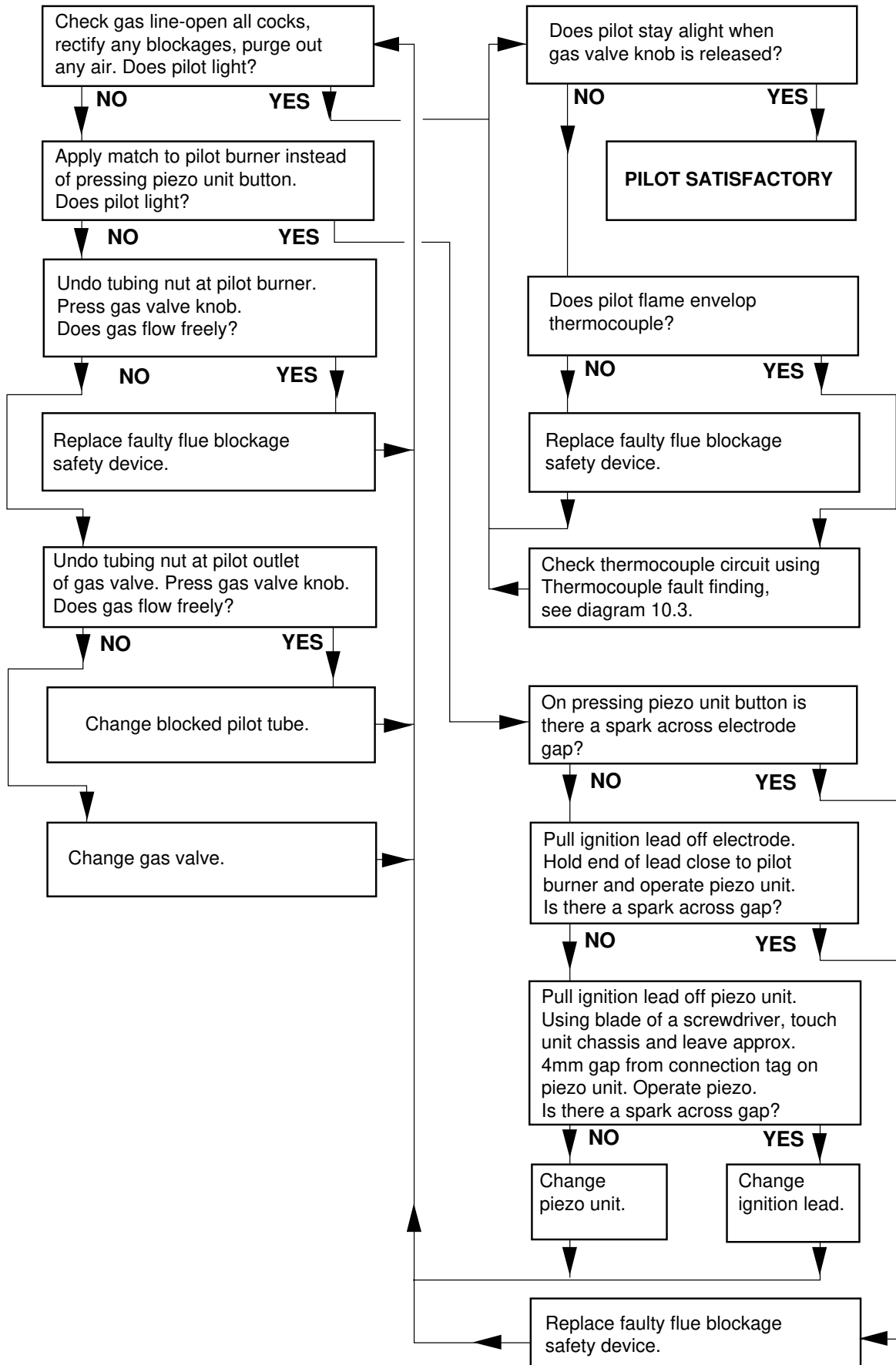

BACK BOILER PILOT FAULT FINDING CHART

Diagram 10.5

11 Spare Parts

When spare parts are required apply to your local supplier.

Please quote the name of the appliance, Glow-worm 56/2 BBU, also the serial number of the back boiler, to be found on the data label on the combustion chamber extension, see diagram 6.1.

If ordering from British Gas the GC number should also be quoted, together with the GC number of the part.

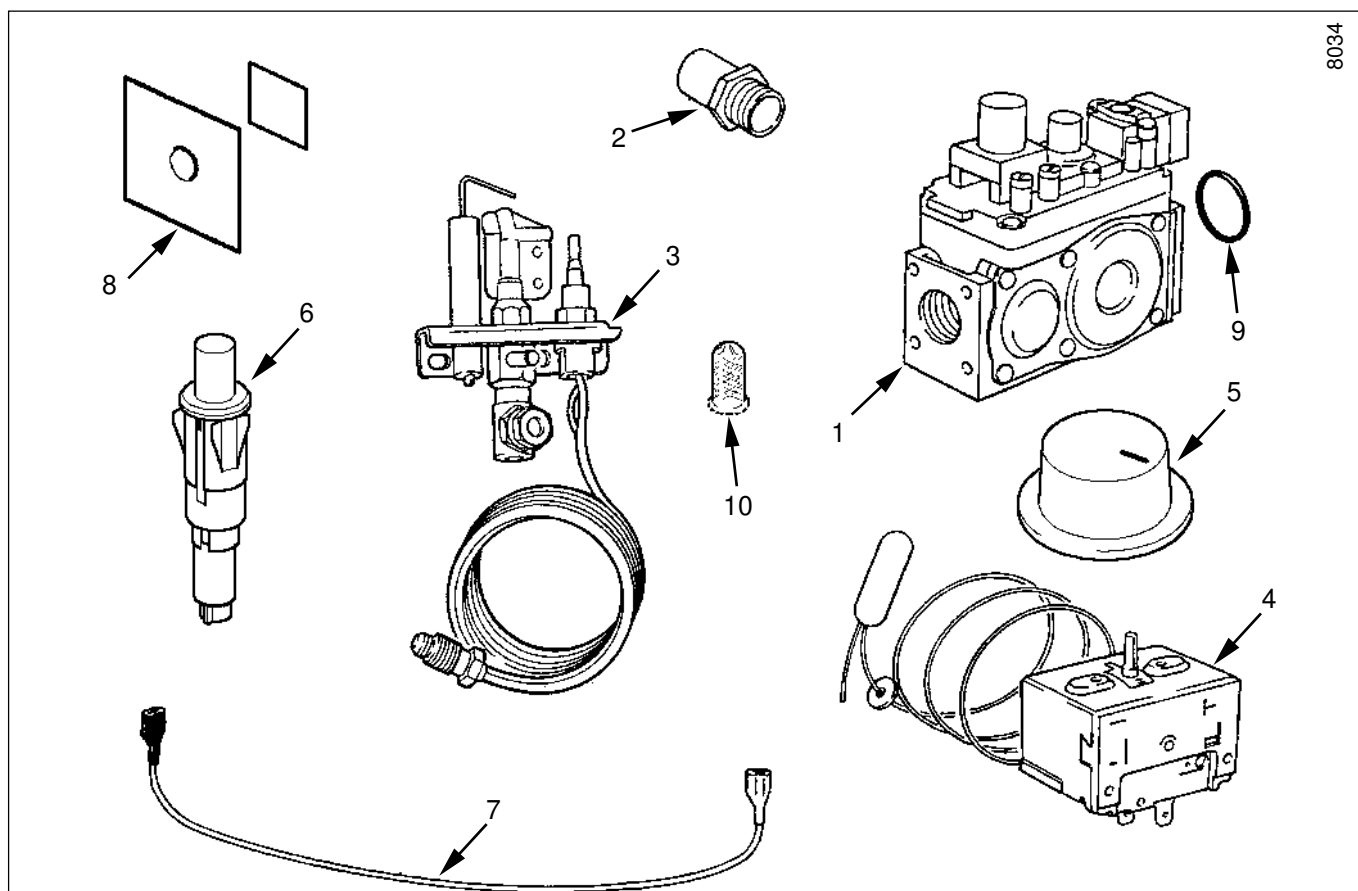

8034

Diagram 11.1

Key No	Part No.	Description	GC Part No
1	426766	Multifunctional control	191 264
2	203001	Injector	355 978
3	451477	Flue blockage safety device	
4	202518	Control thermostat	191 273
5	204687	Control thermostat knob	*****
6	202713	Piezo unit	*****
7	WW4603	Ignition lead	191 267
8	801236	Mica window and Gasket	*****
9	208068	"O" ring	334 658
10	208680	Sensing tube filter	

Control of Substances Hazardous to Health

Information for the Installer and Service Engineer.

Under Section 6 of The Health and Safety at Work Act 1974, we are required to provide information on substances hazardous to health.

The adhesives and sealants used in this appliance are cured and give no known hazard in this state.

INSULATION PADS/CERAMIC FIBRE, GLASSYARN

These can cause irritation to skin, eyes and the respiratory tract.

If you have a history of skin complaint you may be susceptible to irritation. High dust levels are usual only if the material is broken.

Normal handling should not cause discomfort, but follow normal good hygiene and wash your hands before eating, drinking or going to the lavatory.

If you do suffer irritation to the eyes or severe irritation to the skin seek medical attention.

THERMOSTATS

These contain very small amounts of xylene in the sealed phial and capillary. If broken, under normal circumstances the fluid does not cause a problem, but in cases of skin contact, wash with cold water.

If swallowed drink plenty of water and seek medical attention.

Because of our constant endeavour for improvement details may vary slightly from those given in these instructions.