

# Installation and service instructions

for contractors

# VIESSMANN

## Vitodens 100-W

Type **WB1B**, 7.9 to 35.0 kW

Wall mounted gas condensing boiler

Natural gas and LPG version

Gas Council no.: 41-819-21; 41-819-22; 41-819-23; 41-819-24;  
41-819-25

*For applicability, see the last page*

## VITODENS 100-W



## Safety instructions



Please follow these safety instructions closely to prevent accidents and material losses.

### Safety instructions explained



#### **Danger**

This symbol warns against the risk of injury.



#### **Please note**

This symbol warns against the risk of material losses and environmental pollution.

### **Note**

*Details identified by the word "Note" contain additional information.*

### **Target group**

These instructions are exclusively designed for qualified personnel.

- Work on gas equipment must only be carried out by a qualified gas fitter.
- Work on electrical equipment must only be carried out by a qualified electrician.
- The system must be commissioned by the system installer or a qualified person authorised by the installer.

### **Regulations**

Observe the following when working on this system

- all legal instructions regarding the prevention of accidents,
- all legal instructions regarding environmental protection,
- the Code of Practice of relevant trade associations,

- all current safety regulations as defined by DIN, EN, DVGW, TRGI, TRF, VDE and all locally applicable standards,
- Gas Safety (Installation & Use) Regulations
  - the appropriate Building Regulation either the Building regulations, the Building Regulation (Scotland), Building Regulations (Northern Ireland),
  - the Water Fittings Regulation or Water Bylaws in Scotland,
  - the current I.E.E. Wiring Regulations.

### **If you smell gas**



#### **Danger**

Escaping gas can lead to explosions which may result in serious injury.

- Never smoke. Prevent naked flames and sparks. Never switch lights or electrical appliances ON or OFF.
- Close the gas shut-off valve.
- Open windows and doors.
- Remove all people from the danger zone.
- Notify your gas or electricity supplier from outside the building.
- Shut off the electricity supply to the building from a safe place (outside the building).

## Safety instructions (cont.)

### If you smell flue gas



#### **Danger**

Flue gas can lead to life-threatening poisoning.

- Shut down the heating system.
- Ventilate the boiler room.
- Close all doors leading to the living space.

### Working on the system

- When using gas as fuel, also close the main gas shut-off valve and safeguard against unauthorised reopening.
- Isolate the system from the power supply and check that it is no longer 'live', e.g. by removing a separate fuse or by means of a main isolator.
- Safeguard the system against unauthorised reconnection.



#### **Please note**

Electronic modules can be damaged by electro-static discharges.

Touch earthed objects, such as heating or water pipes, to discharge static loads.

### Repair work



#### **Please note**

Repairing components which fulfil a safety function can compromise the safe operation of your heating system.

Replace faulty components only with original Viessmann spare parts.

### Ancillary components, spare and wearing parts



#### **Please note**

Spare and wearing parts which have not been tested together with the heating system can compromise its function. Installing non-authorised components and non-approved modifications/conversion can compromise safety and may invalidate our warranty. For replacements, use only original spare parts from Viessmann or those which are approved by Viessmann.

## Index

### Installation instructions

#### Preparing for installation

Product information.....	5
Preparing for installation.....	6

#### Installation sequence

Fitting the boiler and making connections.....	9
Opening the control unit casing.....	14
Electrical connections.....	14

### Service instructions

#### Commissioning, inspection, maintenance

Steps - commissioning, inspection and maintenance.....	18
Further details regarding the individual steps.....	19

#### Troubleshooting

Function sequence and possible faults.....	31
Fault messages on the display.....	32
Repairs.....	37

#### Gas type conversion

Changing from LPG to natural gas.....	44
---------------------------------------	----

#### Control unit

Functions and operating conditions in weather-compensated mode.....	47
---	----

#### Designs

Connection and wiring diagram.....	49
------------------------------------	----

Parts lists.....	51
------------------	----

Specification.....	54
--------------------	----

#### Certificates

Declaration of conformity.....	55
--------------------------------	----

Keyword index.....	56
--------------------	----

## Product information

### **Vitodens 100-W, WB1B**

Preset for operation with natural gas.

Conversion to LPG P requires a gas conversion kit.

In principle, the Vitodens 100-W may only be supplied to the countries listed on the type plate. For deliveries to alternative countries, an approved contractor, on his own initiative, must arrange individual approval in accordance with the law of the country in question.

## Preparing for installation

### Preparing for the boiler installation

#### Dimensions and connections

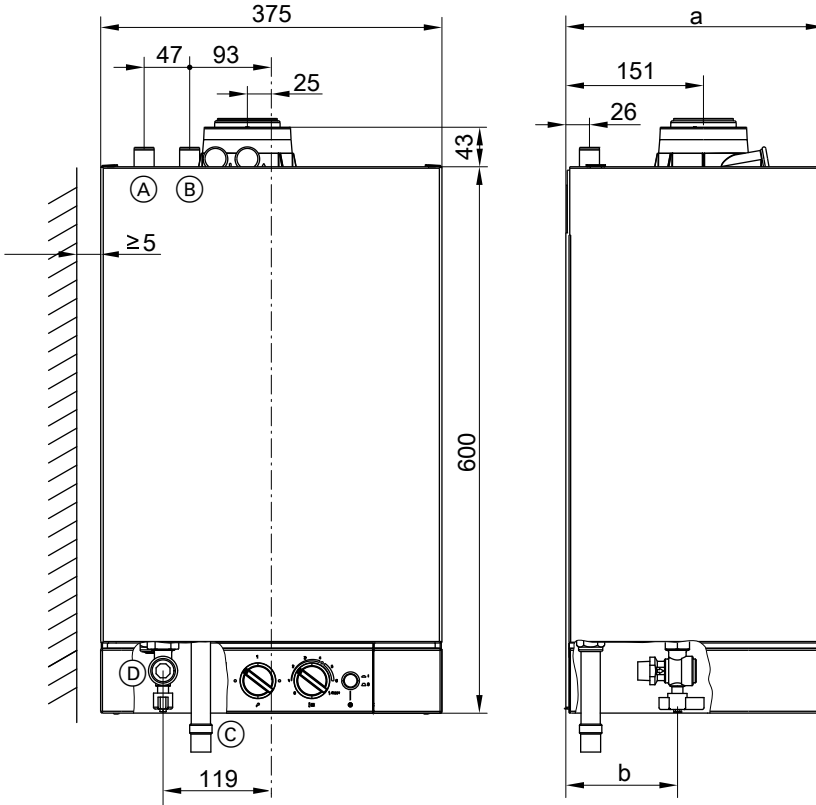

- (A) Heating flow  $\varnothing$  22 mm  
 (B) Heating return  $\varnothing$  22 mm  
 (C) Condensate drain: Plastic hose  
 $\varnothing$  22 mm  
 (D) Gas connection R  $\frac{1}{2}$

Rated heating output range	kW	7.9 - 13	7.9 - 16	7.9 - 19	7.9 - 26	11.0 - 35
a	mm	285	285	285	285	340
b	mm	123	123	123	123	171

**Preparing for installation (cont.)**

**Fitting the wall mounting bracket**

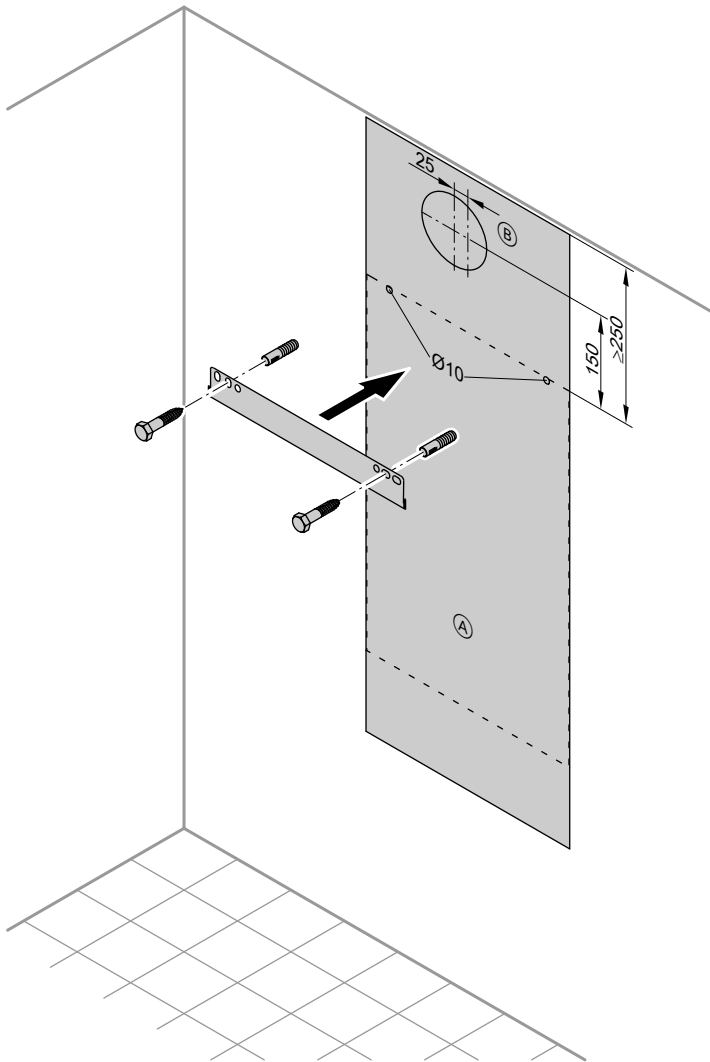

Ⓐ Vitodens installation template

Ⓑ Opening for the balanced flue

## Preparing for installation (cont.)

1. Align the supplied installation template on the wall.
2. Drill  $\varnothing$  10 mm holes and insert the rawl plugs supplied.
3. Fit wall mounting bracket with screws supplied.

### Preparing the connections



#### **Please note**

To prevent equipment damage, install all pipework free of load and torque stresses.

1. Prepare the water connections. Flush the heating system.
2. Prepare the gas connection.
3. Prepare the electrical connections. Observe applicable IEEE standards.
  - A 1.5 m power cable is fitted in the delivered condition.
  - A 1.5 m connecting cable for the circulation pump is provided separately.
  - Accessory cables:  
NYM-O two-core min. 0.5 mm<sup>2</sup>.

## Fitting the boiler and making connections

### Removing the front panel and mounting the boiler

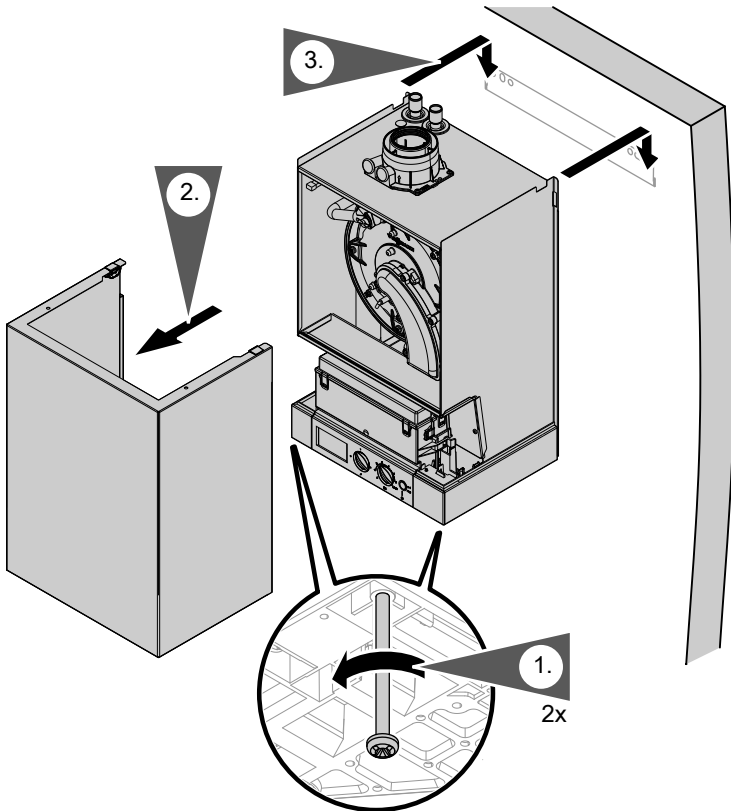

1. Undo screws at the bottom of the boiler; do not remove completely.

2. Remove front panel.

3. Hook the boiler into the wall mounting bracket.

**Note**

*Align the boiler vertically or horizontally on all three axes.*

## Fitting the boiler and making connections (cont.)

### Making connections on the water side

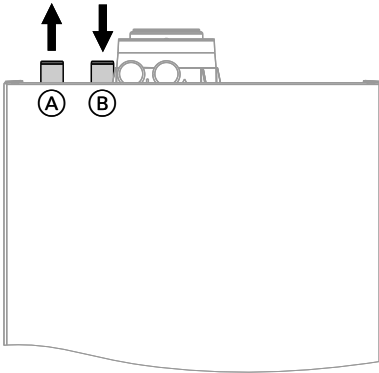

**Note**

*Install a shut-off valve and drain & fill valve on site in the heating water return.*

- (A) Heating water flow
- (B) Heating water return

### Y-plan system

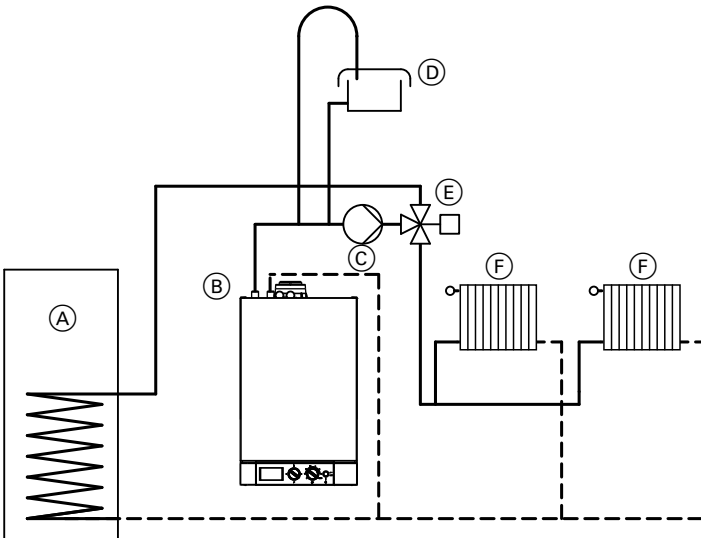

- (A) Cylinder
- (B) Vitodens 100-W
- (C) Circulation pump
- (D) Feed and expansion tank

## Fitting the boiler and making connections (cont.)

Ⓔ 3-way diverter valve

Ⓕ Radiators

### Gas connection

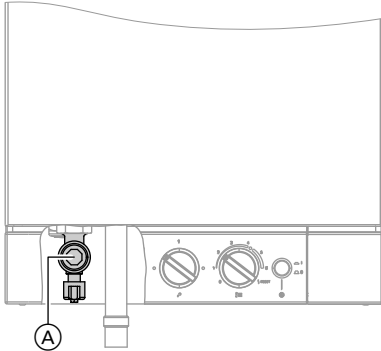

1. Connect gas shut-off valve to connection Ⓔ.
2. Carry out a tightness test.

#### Note

Only use suitable and approved leak detection agents (EN 14291) and devices for the tightness test. Leak detection agents with unsuitable constituents (e.g. nitrites, sulphides) can cause material damage. Remove residues of the leak detection agent after testing.



#### Please note

Excessive test pressure may damage the boiler and the gas valve.

Max. test pressure 150 mbar. Where higher pressure is required for tightness tests, disconnect the boiler and the gas valves from the gas supply pipe (undo the fitting).

3. Vent the gas line.

## Fitting the boiler and making connections (cont.)

### Condensate connection

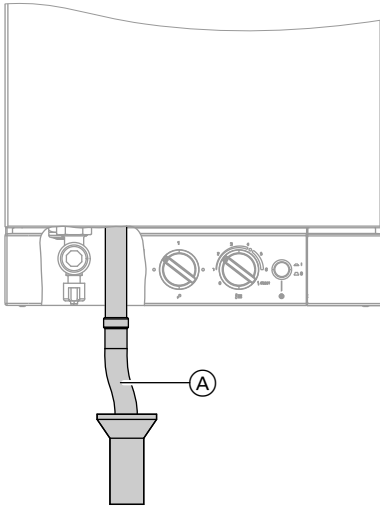

1. Pull condensate pipe (A) so far out of the appliance that no unnecessary bends are created inside the appliance. Ensure that the siphon is properly connected.
2. Connect condensate pipe (A) with a constant fall and a pipe vent to the public sewage system. Observe the local waste water regulations.

- Connecting the condensate hose internally to the domestic waste water system, either directly or via a drip water funnel (tundish) is recommended.
- If the condensate pipe is routed outside the building, use a pipe of at least  $\varnothing$  30 mm and insulate it against frost. Avoid long external pipelines.



#### Please note

A frozen condensate pipe can result in faults and boiler damage.  
Always insulate condensate lines against frost.

- Observe the local building regulations.

## Fitting the boiler and making connections (cont.)

### Filling the condensate connection siphon with water

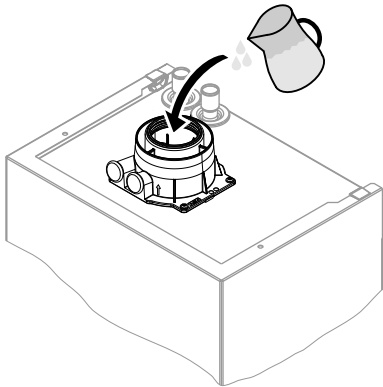

#### Please note

At commissioning, flue gas may be emitted from the condensate drain.

Therefore fill the siphon with water before commissioning.

Pour a minimum of 0.3 l of water into the flue outlet.

### Balanced flue connection

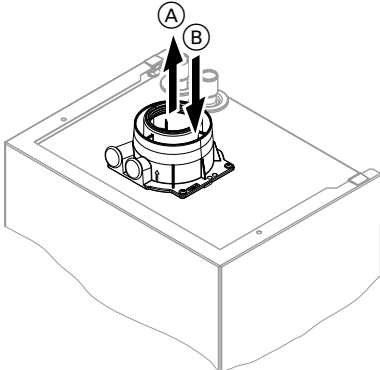

Connect the balanced flue.

During installation and positioning of the flue system, observe building regulations Part L and BS 5440.



Flue system installation instructions.

- (A) Flue gas
- (B) Ventilation air

## Opening the control unit casing



### Please note

Electronic assemblies can be damaged by electrostatic discharge.

Before beginning work, touch earthed objects, such as heating or water pipes, to discharge static loads.

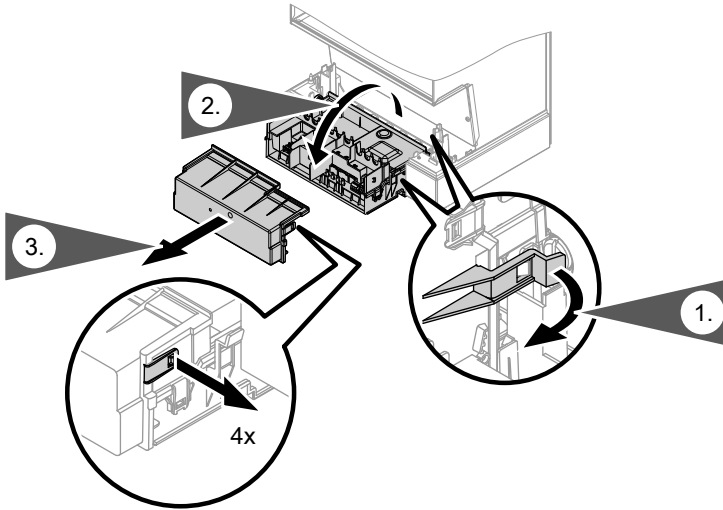

## Electrical connections



### Information on connecting accessories

For this connection, observe the separate installation instructions provided with the accessories.

**Electrical connections (cont.)**

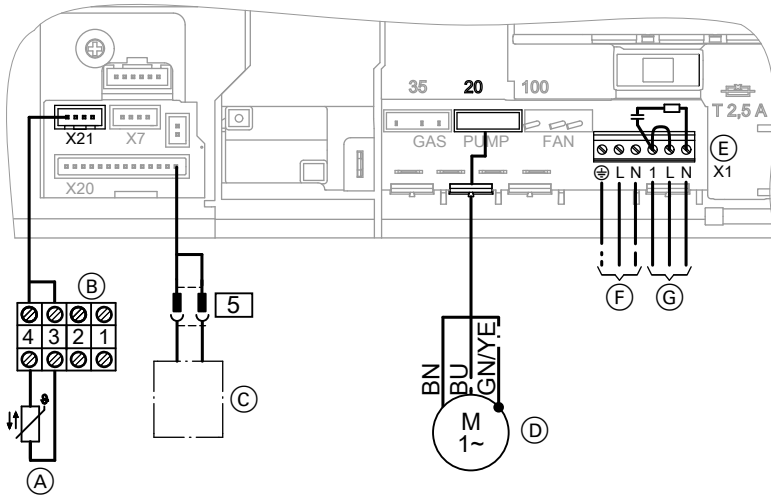

- (A) Only for weather-compensated mode:  
Outside temperature sensor (accessory).
- (B) Connecting cable (accessory).
- (C) Terminal box cylinder demand (accessory; see separate installation instructions).
- (D) Circulation pump connecting cable (supplied).

**Note**

*If the circulation pump is not connected to the control unit, connect an external frost stat.*

- (E) Jumper (1 - L).

- (F) Power supply (230 V, 50 Hz).



**Danger**

Incorrect core allocation can result in serious injury and damage to the appliance. Never interchange cores "L1" and "N".

The power supply must be from a fused spur with a 2 pole isolator switch, fitted with a 3 A fuse. Wire the power supply with a neutral conductor. Connect water pipes to the earth bonding of the building in question.

- (G) Connections for external 230 V controls:
  - Vitotrol 100 (room temperature controller)



## Electrical connections (cont.)



Separate installation instructions

- On-site room temperature controller
- Input for Y-plan or S-plan heating systems

Remove jumper  $\text{\textcircled{E}}$  (1 - L) when connecting a 230 V control, leaving the capacitor in place.

Take power for external controls from "L" and "N". The switched live to start the boiler goes into "1". Please note that if there are two circuits connected, e.g. heating and hot water, you cannot use a plug-in timer or programmable room thermostat receiver. Two channel switching must be external to the boiler.

The only exception is if weather compensation is also fitted.

## Outside temperature sensor (accessory)

1. Fit outside temperature sensor.

Installation site:

- North or north-westerly wall, 2 to 2.5 m above ground level; in multi storey buildings, in the upper half of the second floor
- Not above windows, doors or ventilation outlets
- Not immediately below balconies or gutters
- Never render over
- Connection:  
2-core lead, length max. 35 m with a cross-section of 1.5 mm<sup>2</sup>

2. Plug the power cable supplied with the outside temperature sensor into slot "X21".

3. Connect the outside temperature sensor to terminals 3 and 4 (see page 15).

**Electrical connections (cont.)****Routing connecting cables and closing the control unit casing****Please note**

Connecting cables will be damaged if they touch hot components.

When routing and securing cables/leads on site, ensure that the maximum permissible temperatures for these cables/leads are not exceeded.

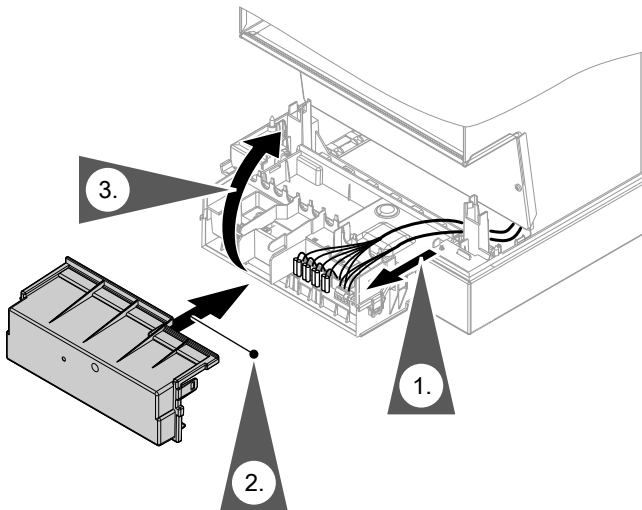

## Steps - commissioning, inspection and maintenance

For further information regarding the individual steps, see the page indicated

				Page
			Commissioning steps	
			Inspection steps	
			Maintenance steps	
•	•	•	1. Filling the heating system.....	19
•	•	•	2. Venting the boiler.....	20
•	•	•	3. Changing to operation with LPG.....	21
•	•	•	4. Checking the static and supply pressure.....	21
•	•	•	5. Checking the CO <sub>2</sub> or O <sub>2</sub> content.....	23
	•	•	6. Burner removal .....	24
	•	•	7. Checking the burner gasket and burner gauze assembly.....	25
	•	•	8. Checking and adjusting electrodes.....	26
	•	•	9. Cleaning the heat exchanger.....	27
	•	•	10. Checking the condensate drain and cleaning the siphon.....	27
	•	•	11. Burner installation .....	28
•	•	•	12. Checking all connections on the heating water side and DHW side for leaks	
•	•	•	13. Checking flue system for unrestricted flow and tightness	
•	•	•	14. Checking firm seating of electrical connections	
•	•	•	15. Checking all gas equipment for tightness at operating pressure .....	29
	•	•	16. Fitting the front panel.....	29
•			17. Instructing the system user.....	30

## Further details regarding the individual steps

### Filling the heating system



#### **Please note**

Unsuitable fill water increases the level of deposits and corrosion and may lead to boiler damage.

- Thoroughly flush the entire heating system prior to filling it with water.
- Only fill with water of potable quality.
- Soften fill water harder than 300 ppm.
- An antifreeze additive suitable for heating systems can be added to the fill water.

Fill and vent the heating system.

## Further details regarding the individual steps (cont.)

### Venting the boiler

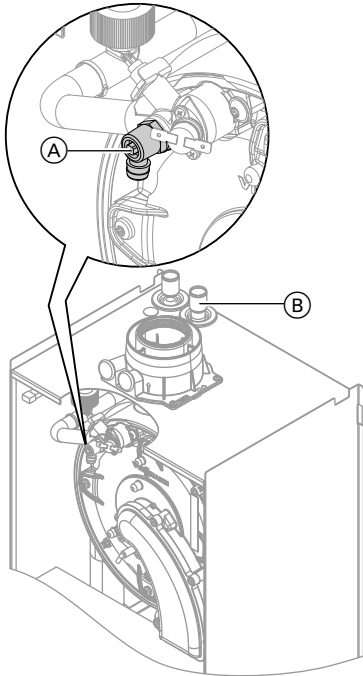

1. Close shut-off valve in heating water return.
2. Remove cover panel.
3. Connect drain hose to air vent valve (A) with a drain connection.
4. Open air vent valve (A) and on-site fill valve in heating water return (B). Vent (flush) under mains pressure until no more air noise can be heard.

#### **Note**

*If the heating system has not been completely vented, the heating water flow rate can be too low. This can lead to the burner being switched off by internal safety equipment before the specified set boiler water temperature is achieved.*

5. First close air vent valve (A) and then the fill valve in heating water return (B).
6. ■ Sealed unvented heating system:  
Adjust operating pressure to  $\geq 0.8$  bar with fill valve (B).  
■ Open vented heating system:  
The static head must be at least 0.2 bar.
7. Open shut-off valve in heating water return.

**Further details regarding the individual steps (cont.)**

**Changing to operation with LPG**

In the delivered condition, the boiler is set up for operation with natural gas. For operation with LPG, change the gas nozzle and convert the gas type in the control unit.

 Separate installation instructions.

Changing from LPG to natural gas - see page 44.

**Checking the static and supply pressure**



**Danger**

CO build-up as a result of incorrect burner adjustment can have serious health implications. Carry out a CO test before and after work on gas appliances.

**Operation with LPG**

*Flush the LPG tank twice during commissioning or replacement. Vent the tank and gas supply line thoroughly after flushing.*

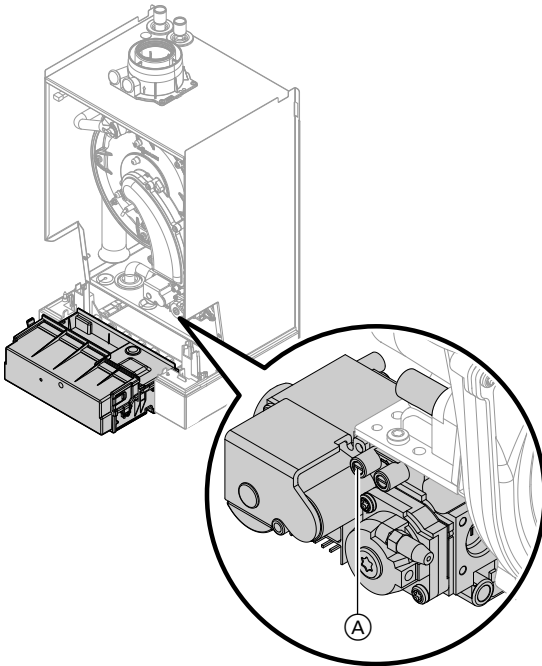

1. Close the gas shut-off valve.



**Further details regarding the individual steps** (cont.)

2. Undo the screw inside the test nipple (A) on the gas train, but do not remove it; then connect the pressure gauge.
3. Open the gas shut-off valve.
4. Check the static pressure.  
Set value: max. 57.5 mbar
5. Start the boiler.
7. Record the actual value in the report on page.  
Take the action shown in the following table.
8. Shut down the boiler, close the gas shut-off valve, remove the pressure gauge and close test nipple (A) with the screw.
9. Open the gas shut-off valve and start the appliance.

**Note**

*During commissioning, the boiler can enter a fault state because of airlocks in the gas line. After approx. 5 s, press **Reset** to reset the burner.*

6. Check the supply (flow) pressure.

Set value:

- Natural gas: 20 mbar
- LPG: 37 mbar

**Note**

*Use a suitable measuring device with a resolution of at least 0.1 mbar to check the supply pressure.*



**Danger**

Gas escaping from the test nipple leads to a risk of explosion.

Check gas tightness at test nipple (A).

**Note**

*The maximum pressure drop between the gas shut-off valve and test nipple (A) on the gas train is 0.5 mbar.*

Supply pressure (flow pressure)		Action
For natural gas	For LPG	
Below 17.4 mbar	Below 25 mbar	Do not start the boiler. Notify your gas supply utility or LPG supplier.
17.4 to 25 mbar	25 to 47 mbar	Start the boiler.
Above 25 mbar	Above 47 mbar	Install a separate gas pressure governor upstream of the system and regulate the pre-charge pressure to 20 mbar for natural gas or 37 mbar for LPG. Notify your gas supply utility or LPG supplier.

## Further details regarding the individual steps (cont.)

### Checking the CO<sub>2</sub> or O<sub>2</sub> content

The Vitodens100-W is factory-set for natural gas. During commissioning or maintenance, the CO<sub>2</sub> and CO have to be measured at the boiler flue adaptor test point to check the flue integrity. Subject to the Wobbe index, the CO<sub>2</sub> content fluctuates between 7.4 % and 10.5 %. CO of up to 500 ppm during ignition is acceptable.

We recommend measuring O<sub>2</sub> as the value is unmistakable regarding lambda (air/gas). The O<sub>2</sub> content fluctuates between 7.5 % and 3.2 %. The CO/CO<sub>2</sub> ratio has to be less than 0.004.

If the actual CO<sub>2</sub> or O<sub>2</sub> and CO values deviate from the stated range, check the balanced flue systems for leaks. If flue installation is OK, change the gas valve.

#### Note

*Operate the appliance with uncontaminated combustion air to prevent operating faults and damage.*

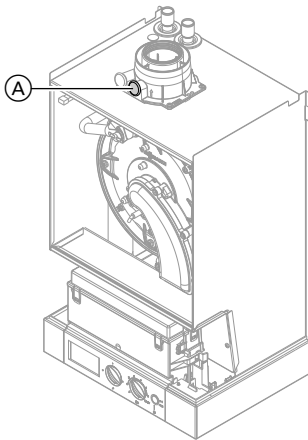

1. Connect a flue gas analyser to flue gas port (A) on the boiler flue connection.
2. Start the boiler.
3. Check the CO<sub>2</sub> or O<sub>2</sub> content.  
If the CO<sub>2</sub> content or O<sub>2</sub> content fall outside the range specified above, carry out the described measures.
4. Shut down the boiler, remove the flue gas analyser and close flue gas port (A).

## Further details regarding the individual steps (cont.)

### Burner removal

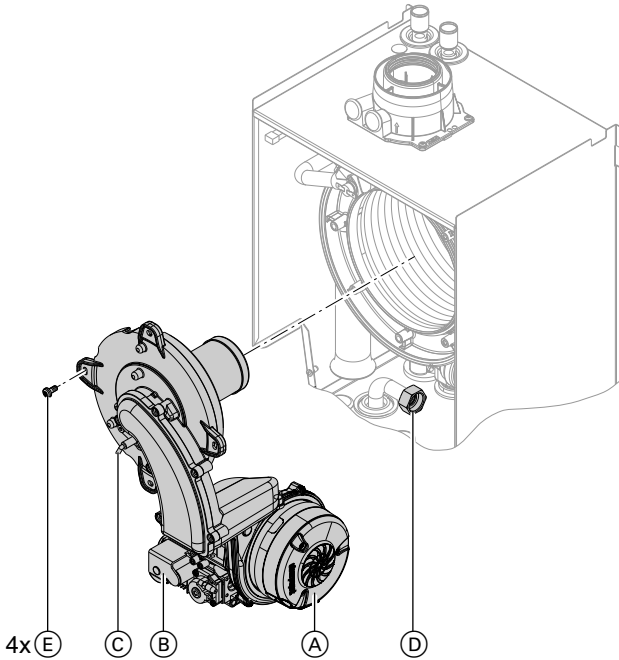

1. Switch off the power.
2. Shut off the gas supply.
3. Disconnect power cables from fan motor (A) and gas valve (B).
4. Open control unit casing (see page 14) and disconnect the lead to ignition electrode (C).
5. Disconnect the venturi extension from fan (A).
6. Release gas supply pipe fitting (D).
7. Undo four screws (E) and remove the burner.



#### Please note

To prevent damage, never rest the burner on the burner gauze assembly.

## Further details regarding the individual steps (cont.)

### Checking the burner gasket and burner gauze assembly

Check burner gasket (A) and burner gauze assembly (D) for damage and replace if necessary.

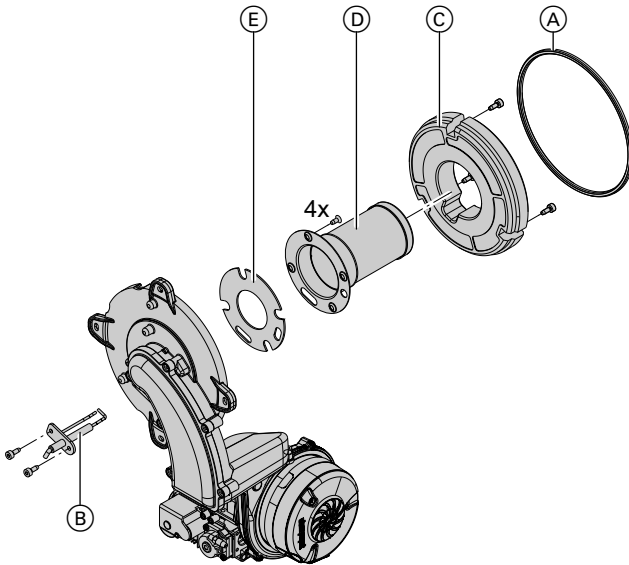

1. Remove electrode (B).
2. Undo the three cheese head screws and remove thermal insulating ring (C).
3. Undo four Torx screws and remove burner gauze assembly (D) with gasket (E).
4. Insert new burner gauze assembly (D) with new gasket (E) and secure.
  - ! **Please note**  
Tighten screws far enough to prevent the components being damaged and to ensure they function correctly.
5. Fit thermal insulation ring (C).
  - ! **Please note**  
Tighten screws far enough to prevent the components being damaged and to ensure they function correctly.



## Further details regarding the individual steps (cont.)

### 6. Fit electrode (B).



#### Please note

Tighten screws far enough to prevent the components being damaged and to ensure they function correctly.

## Checking and adjusting electrodes

1. Check the electrode for wear and contamination.
2. Clean the electrode with a small brush (not with a wire brush) or sandpaper.
3. Check the electrode gaps. If the gaps are not as specified or the electrode is damaged, replace and align the electrode together with a new gasket.

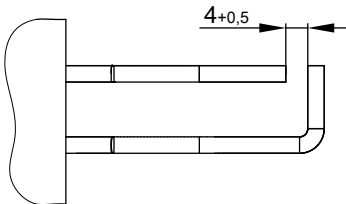
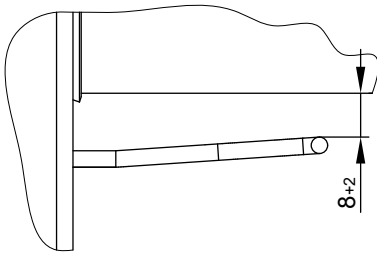

#### Please note

Tighten screws far enough to prevent the components being damaged and to ensure they function correctly.

## Further details regarding the individual steps (cont.)

### Cleaning the heat exchanger

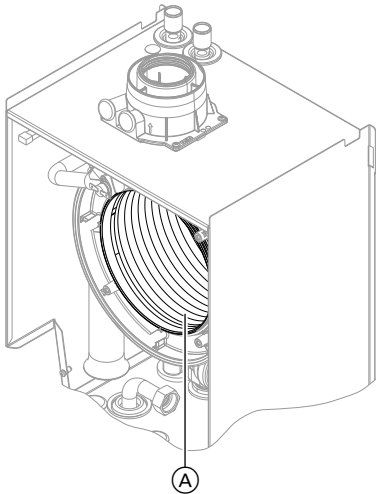

- !** **Please note**  
Scratches on parts that are in contact with flue gas can lead to corrosion.  
**Never use brushes to clean the heat exchanger.**

Use a vacuum cleaner to remove deposits from heat exchangers (A) in the combustion chamber.

- If necessary, spray heat exchanger (A) with slightly acidic, chloride-free cleaning agents based on phosphoric acid and let the solution soak in for at least 20 min.
- Flush heat exchanger (A) thoroughly with water.

### Checking the condensate drain and cleaning the siphon

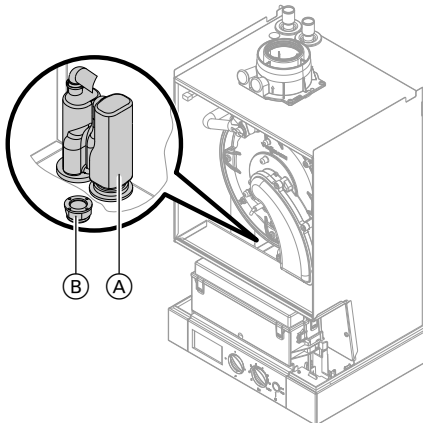

- Check that the condensate can drain freely at siphon (A).
- Place an appropriate drip pan below siphon (A).
- Undo locking cap (B) and drain the contents of siphon (A) into the drip pan.
- Refit locking cap (B) with a gasket.
- Fill siphon (A) with water. Also pour approx. 0.3 l of water into the combustion chamber.

## Further details regarding the individual steps (cont.)

### Burner installation

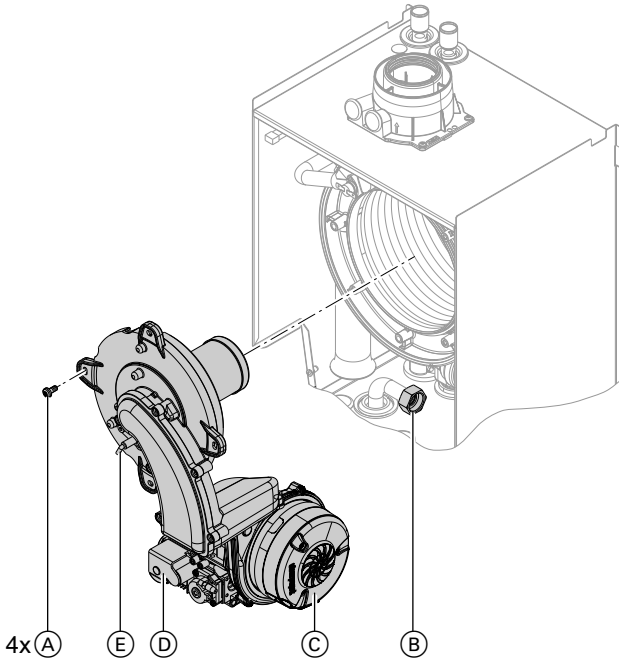

1. Fit burner and tighten four screws (A) crosswise.



#### Please note

Tighten screws far enough to prevent the components being damaged and to ensure they function correctly.

2. Insert new gasket and tighten the fittings on gas supply pipe (B).
3. Connect the venturi extension to fan (C).
4. Connect electrical cables to fan motor (C) and gas valve (D).
5. Plug ignition electrode cable (E) into the control unit and close the control unit casing.
6. Reopen gas supply and switch on power supply.
7. Check the gas connections for tightness.



#### Danger

Escaping gas leads to a risk of explosion.  
Check all fittings for gas tightness.

**Further details regarding the individual steps (cont.)**

**Checking all gas equipment for tightness at operating pressure**



**Danger**

Escaping gas leads to a risk of explosion.  
Check gas equipment for tightness.

**Note**

*Only use suitable and approved leak detection agents (EN 14291) and devices for the tightness test. Leak detection agents with unsuitable constituents (e.g. nitrites, sulphides) can cause material damage.*

*Remove residues of the leak detection agent after testing.*

**Fitting the front panel**

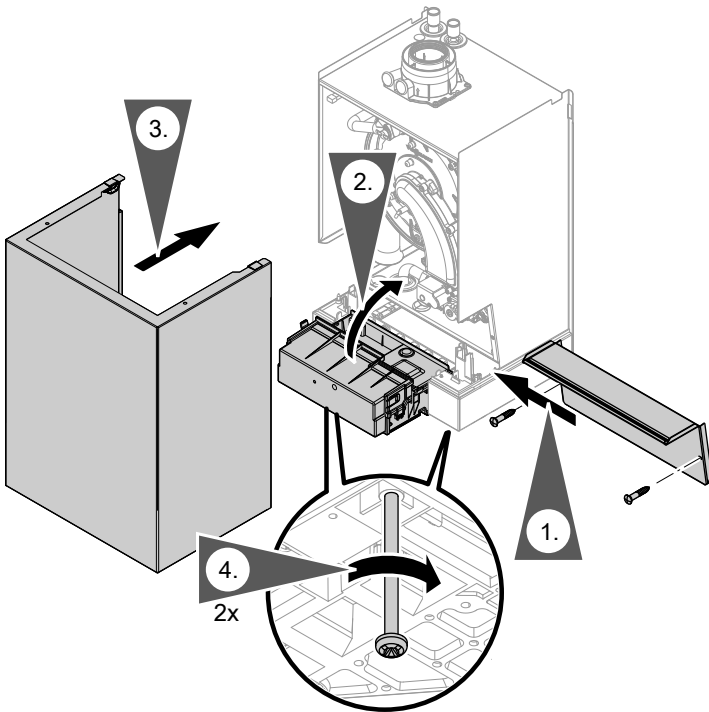

## **Further details regarding the individual steps (cont.)**

### **Instructing the system user**

The system installer must hand the operating instructions to the system user and instruct the user in operating the system.

## Function sequence and possible faults

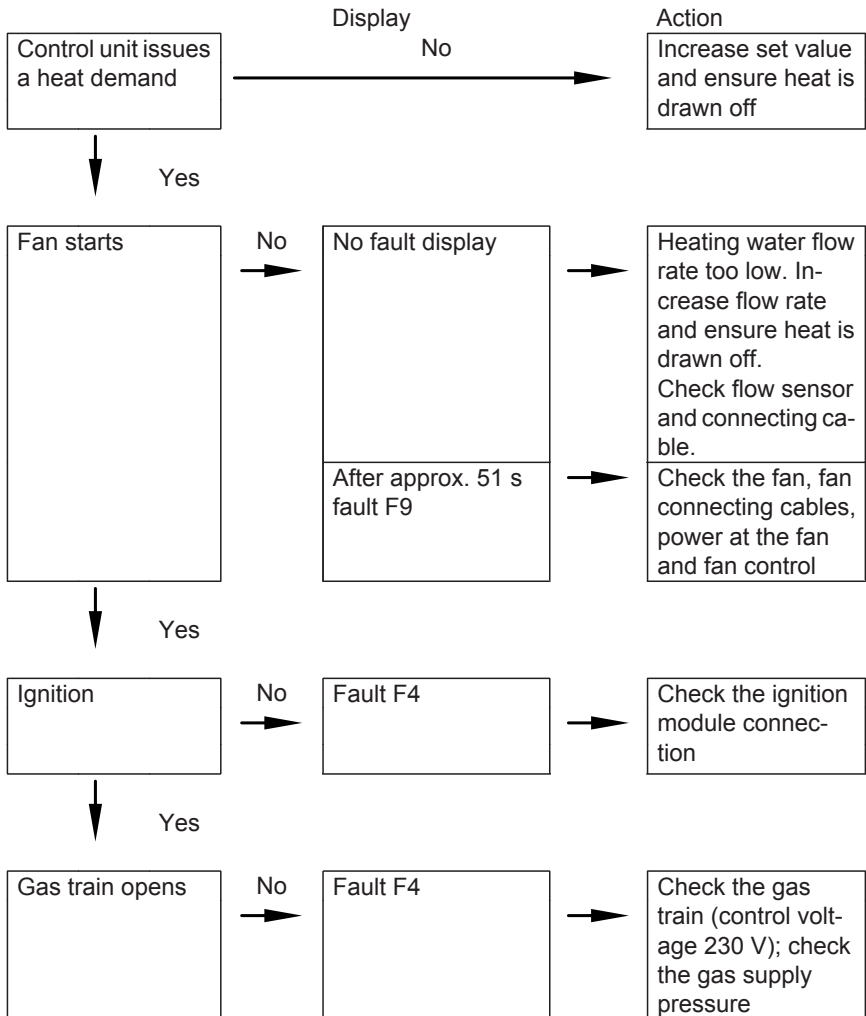

**Function sequence and possible faults (cont.)**

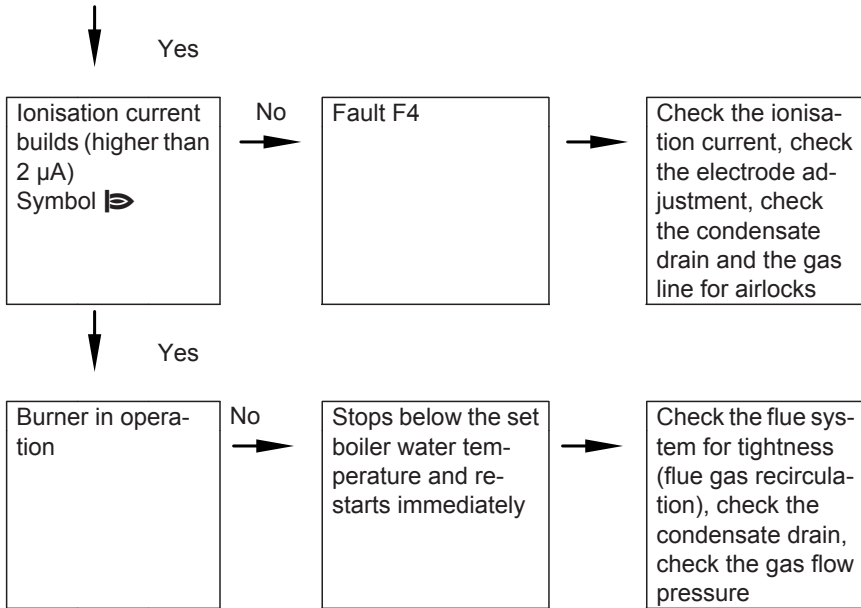

**Fault messages on the display**

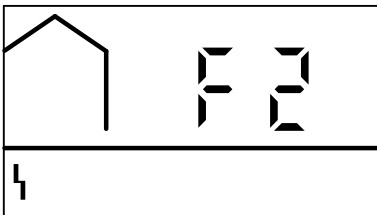

Faults are indicated by a flashing fault code with fault symbol "I" on the display.

For fault code explanations see the following table.

- Flashing fault symbol "I": Reset with "I RESET" (see page 36) after correcting the fault.
- Constantly displayed fault symbol "I": Automatic reset after the fault has been remedied.

**Fault messages on the display** (cont.)

<b>Displayed fault code</b>	<b>System characteristics</b>	<b>Cause</b>	<b>Measures</b>
10	Constant mode	Short circuit, outside temperature sensor	Check the outside temperature sensor and lead (see page 38).
18	Constant mode	Lead break, outside temperature sensor	Check the outside temperature sensor and lead (see page 38).
30	Burner blocked	Short circuit, boiler water temperature sensor	Check the boiler water temperature sensor (see page 39).
38	Burner blocked	Lead break, boiler water temperature sensor	Check the boiler water temperature sensor (see page 39).
50	No DHW heating	Terminal box cylinder demand fault	Check terminal box connections and replace the terminal box if required.
58	No DHW heating	Terminal box cylinder demand fault	Check terminal box connections and replace the terminal box if required.
60	Burner blocked	Short circuit, return temperature sensor	Check the return temperature sensor (see page 39).
68	Burner blocked	Lead break, return temperature sensor	Check the return temperature sensor (see page 39).
A9	Control mode without Open Therm device	Communication error Open Therm device	Check connections and cable; replace Open Therm device if required.
b0	Burner blocked	Short circuit, flue gas temperature sensor	Check the sensor (see page 41).
b8	Burner blocked	Lead break, flue gas temperature sensor	Check the sensor (see page 41).
E5	Burner blocked	Internal fault	Check the ionisation electrode and connecting cables. Press "Reset" (see page 36).
F0	Burner blocked	Internal fault	Replace control unit.

**Fault messages on the display (cont.)**

<b>Displayed fault code</b>	<b>System characteristics</b>	<b>Cause</b>	<b>Measures</b>
F1	Burner in a fault state	Max. flue gas temperature exceeded	Check heating system fill level. Check circulation pump. Vent the system. Press "Reset" (see page 36).
F2	Burner in a fault state	The temperature limiter has responded	Check heating system fill level. Check circulation pump. Vent the system. Check temperature limiter and connecting cables. Press "Reset" (see page 36).
F3	Burner in a fault state	Flame signal is already present at burner start	Check ionisation electrode and connecting cable. Press "Reset" (see page 36).
F4	Burner in a fault state	No flame signal detected	Check the ionisation electrode and connecting cables, check the gas pressure, check the gas train, ignition, ignition module and condensate drain. Press "Reset" (see page 36).
F8	Burner in a fault state	Fuel valve closes too late	Check gas train. Check both control paths. Press "Reset" (see page 36).
F9	Burner in a fault state	Fan speed too low during burner start	Check fan, fan connecting cables and power supply; check fan control. Press "Reset" (see page 36).
FA	Burner in a fault state	Fan not at standstill	Check fan, fan connecting cables and fan control. Press "Reset" (see page 36).

**Fault messages on the display (cont.)**

<b>Displayed fault code</b>	<b>System characteristics</b>	<b>Cause</b>	<b>Measures</b>
FC	Burner blocked	Electrical fan control (control unit) faulty	Check fan connecting cable; if required, replace or replace control unit.
Fd	Burner blocked	Fault, burner control unit	Check ignition electrodes and connecting cables. Check whether a strong interference (EMC) field exists near the appliance.  Press "Reset" (see page 36). Replace control unit if fault persists.
FF	Burner blocked	Fault, burner control unit	Check ignition electrodes and connecting cables. Check whether a strong interference (EMC) field exists near the appliance.  Press "Reset" (see page 36). Replace control unit if fault persists.

## Fault messages on the display (cont.)

### Press reset

**Note**

Only press RESET if fault symbol "⊥" flashes.

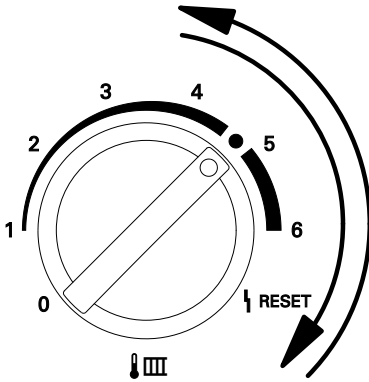

Turn rotary selector "⊥" between 1 s and 2 s to position "⊥ RESET" and then back to the control range.

Repairs

Remove front panel and pivot control unit downwards

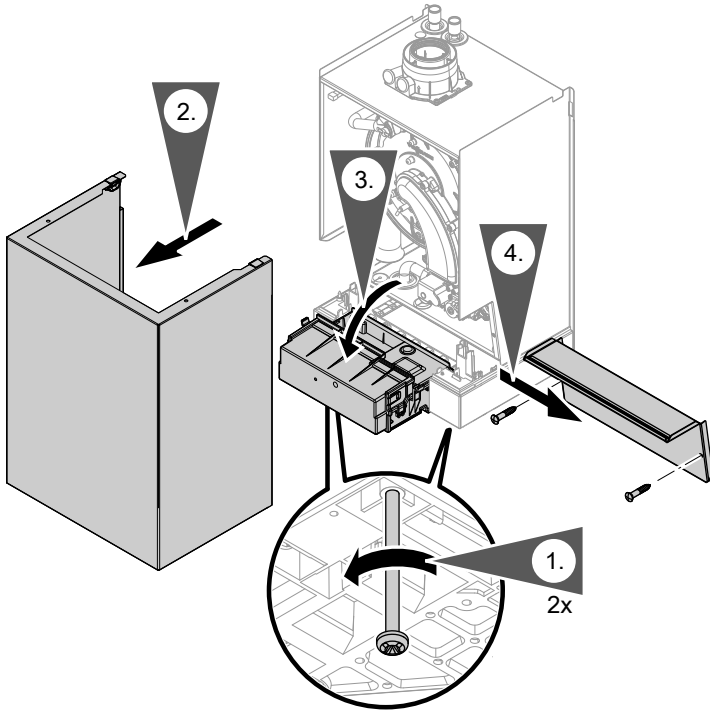

## Repairs (cont.)

### Outside temperature sensor

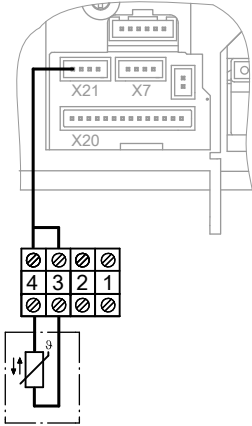

1. Open the control unit casing. See page 14.
2. Disconnect leads from outside temperature sensor.

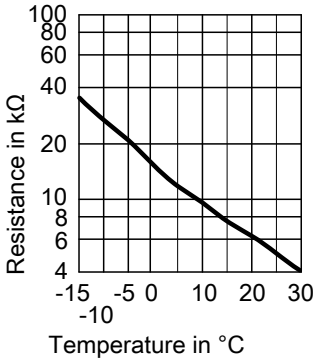

3. Check the sensor resistance and compare it with the curve.
4. Replace the sensor in the case of severe deviation.

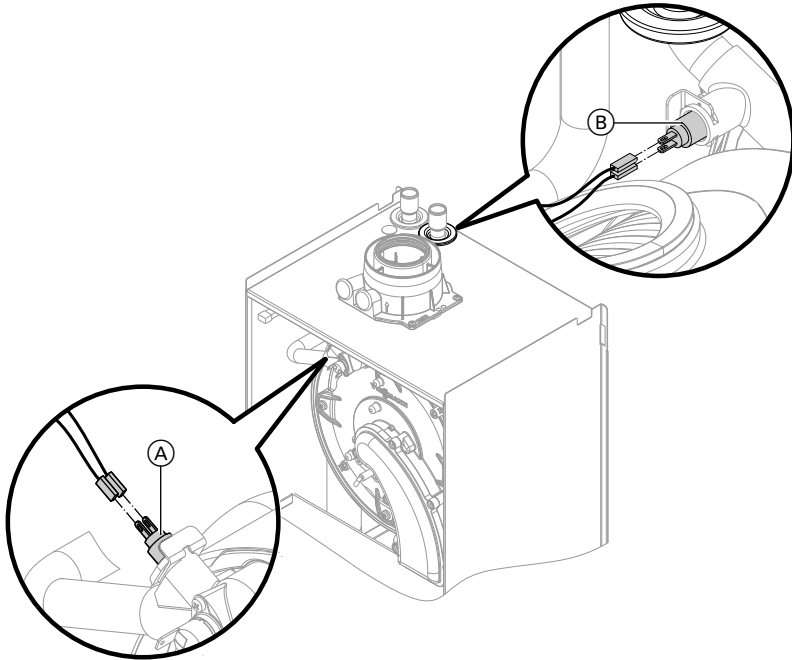
**Repairs** (cont.)**Checking the boiler water temperature sensor and return temperature sensor**

1. Remove the leads from the boiler water temperature sensor (A) or return temperature sensor (B) and check the resistance.

## Repairs (cont.)

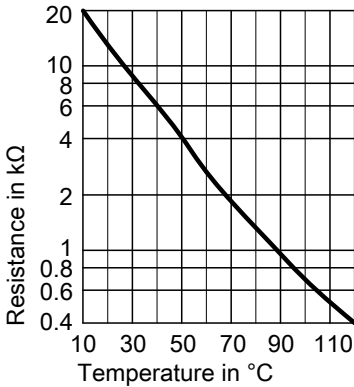

### Checking volumetric flow rate

The volumetric flow rate through the boiler is monitored by recording the differential between boiler water temperature and return temperature. Monitoring of the temperature spread with the boiler water temperature sensor and the return temperature sensor is an additional safety mechanism.

2. Check the sensor resistance and compare it with the curve.
3. In the case of severe deviation, drain the boiler on the heating water side and replace the sensor.



#### **Danger**

The boiler water temperature sensor is immersed in the heating water (risk of scalding).  
Drain the boiler before replacing the sensor.

- In the case of differentials  $> 25 \text{ K} / < 30 \text{ K}$ , the burner is operated at lower heating output.
  - In the case of differentials  $> 30 \text{ K}$ , the burner is switched off.
- In such cases, check whether the heating system is adequately vented and the circulation pump is pumping sufficient heating water.

**Repairs** (cont.)

**Checking the flue gas temperature sensor**

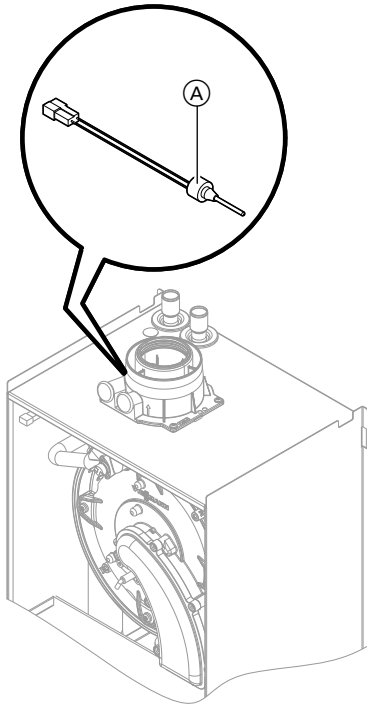

1. Remove the leads from the flue gas temperature sensor (A) and check the resistance.

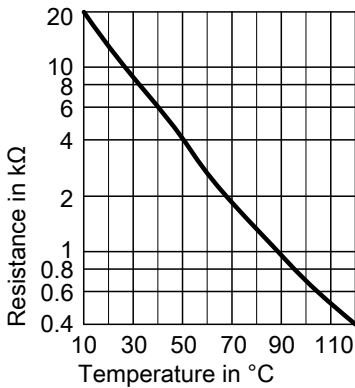

2. Check the sensor resistance and compare it with the curve.
3. Replace the sensor in the case of severe deviation.

## Repairs (cont.)

### Checking the temperature limiter

If the burner control unit cannot be reset after a fault shutdown, although the boiler water temperature is below approx. 95 °C, check the temperature limiter.

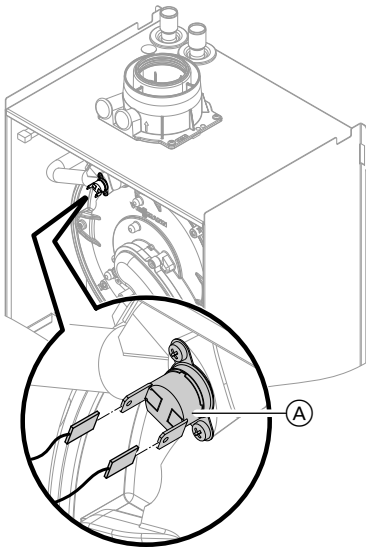

1. Disconnect the leads from temperature limiter (A).
2. Check the continuity of the temperature limiter with a multimeter.
3. Remove the faulty temperature limiter.
4. Install a new temperature limiter.
5. Press "Reset" at the control unit (see page 36).

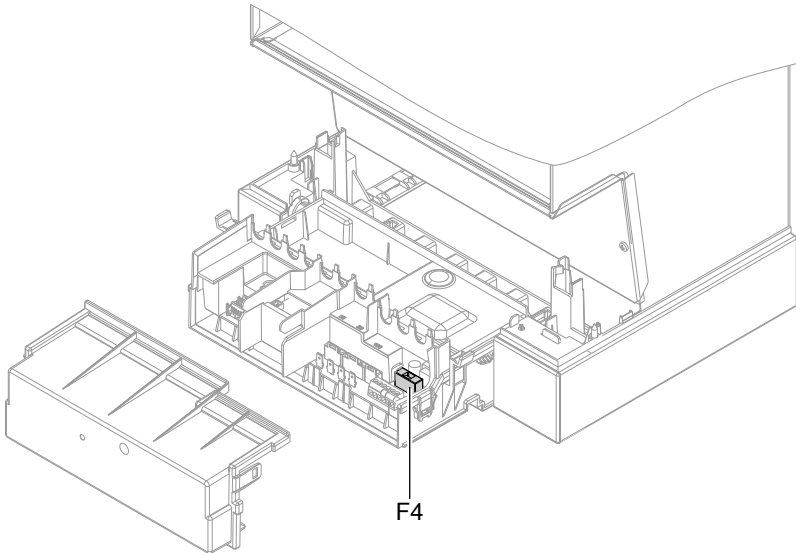
**Repairs** (cont.)**Checking the fuse**

1. Switch off the power.
2. Open control unit casing (see page 14).
3. Check fuse F4.

## Changing from LPG to natural gas

### Replacing the gas restrictor

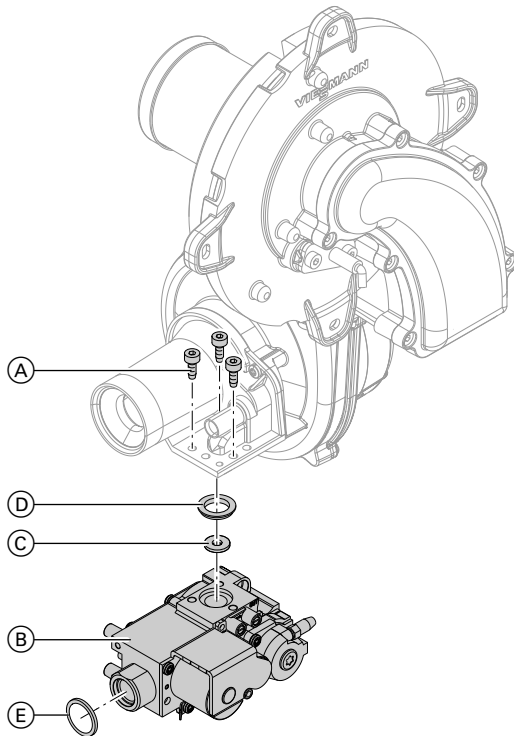

1. Removing the burner (see page 24).
2. Undo three screws (A) and remove gas train (B).
3. Remove gas restrictor (C) (if installed) from gas train (B) and insert new gas restrictor (C) into gas train (B).
4. Fit gas train (B) with new gasket (D).



#### **Please note**

Tighten screws far enough to prevent the components being damaged and to ensure they function correctly.

## Changing from LPG to natural gas (cont.)

5. Refit burner with new gasket (E) and tighten the union nuts.



### Please note

Tighten union nuts far enough

to prevent the components being damaged and to ensure they function correctly.

## Changing the gas type at the control unit

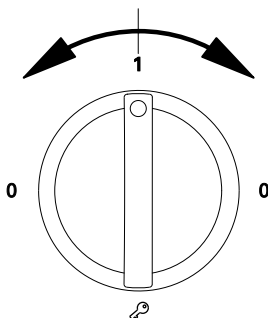
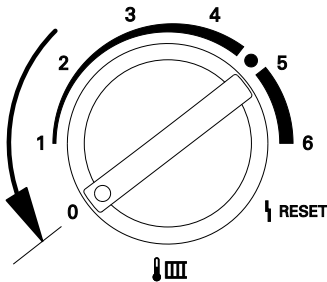
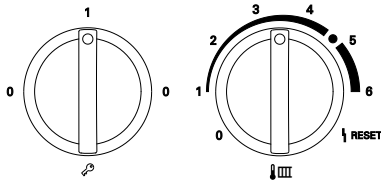

1. Turn ON/OFF switch ON.
2. Turn both rotary selectors "1" and "flame icon" simultaneously to their centre position.  
"SERV" appears on the display.
3. Turn rotary selector "flame icon" fully anti-clockwise within 2 s.  
The display shows "0" and the selected value flashes.
4. Turn the rotary selector "1" to convert the control unit to natural gas or LPG.  
The display shows:
  - "0" for operation with natural gas or
  - "1" for operation with LPG.



## Changing from LPG to natural gas (cont.)

5. Do **not** adjust the rotary selectors for 15 s. The set operating mode is then saved and the control unit returns to standard mode.
6. Switch ON/OFF switch OFF and ON again. The selected gas type is now enabled.

## Checking the CO<sub>2</sub> content

See page 23.

## Functions and operating conditions in weather-compensated mode

In weather-compensated mode, the boiler water temperature is regulated subject to the outside temperature.

### Note

*Y-plan and S-plan systems cannot be operated in weather-compensated mode.*

*For further information, see separate terminal box cylinder demand (accessory) installation instructions.*

### Heating curve of weather-compensated control unit

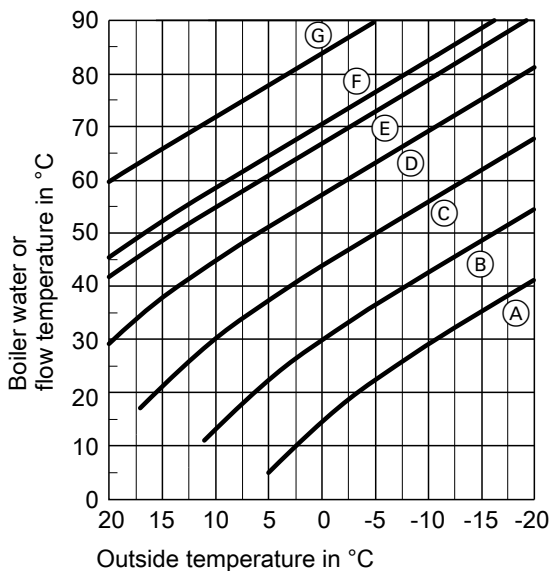

Rotary selector setting "🌡️📊"

- Ⓐ = 1
- Ⓑ = 2
- Ⓒ = 3
- Ⓓ = 4
- Ⓔ = delivered condition
- Ⓕ = 5
- Ⓖ = 6

### Frost protection function

Frost protection function is only possible when an outside temperature sensor is connected.

At an outside temperature  $< 5^{\circ}\text{C}$ , the frost protection function is enabled. The burner is switched on and the boiler water temperature is held at  $20^{\circ}\text{C}$ .

## Functions and operating conditions in... (cont.)

### **Note**

*The frost protection function is only enabled if the circulation pump is connected to the boiler control unit. Otherwise install an external frost stat.*

# Connection and wiring diagram

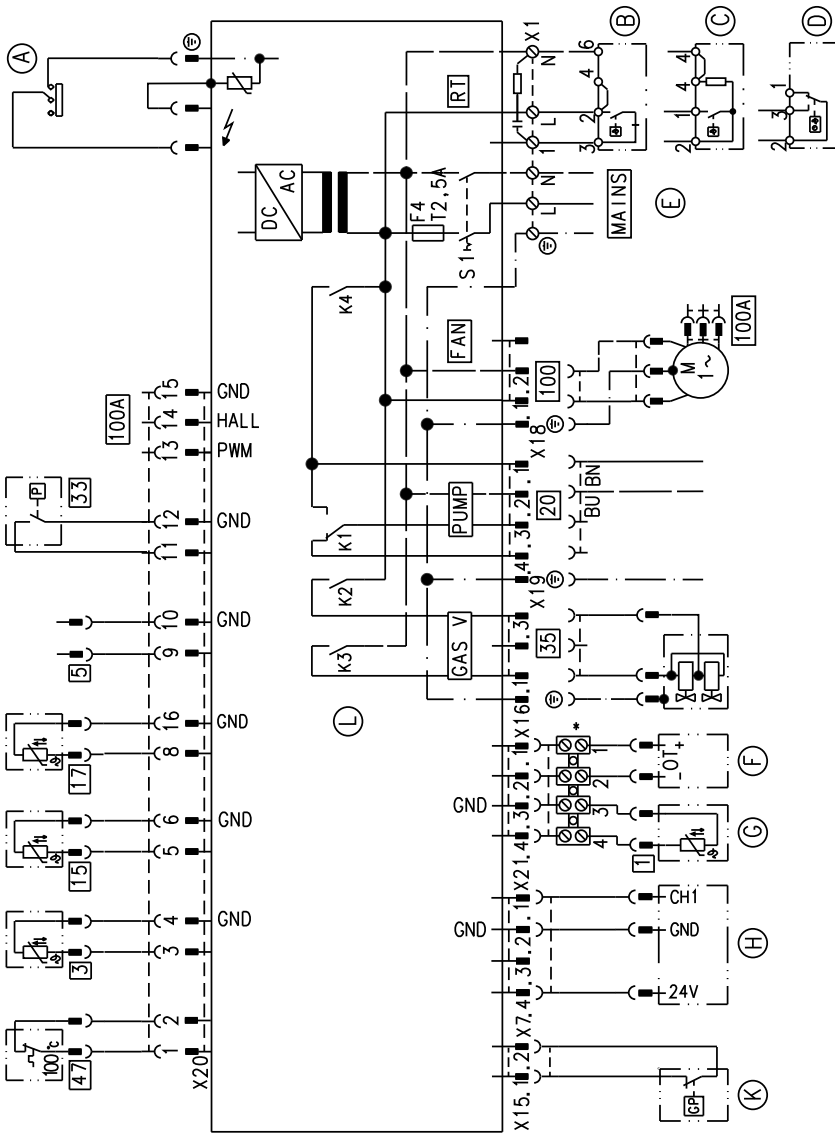

(A) Ignition/ionisation

(B) Vitotrol 100, type UTA or on-site room temperature controller (switched 230 V input)

**Connection and wiring diagram (cont.)**

- |   |   |
|---|---|
| <ul style="list-style-type: none"> <li>Ⓒ Vitotrol 100, type RT or on-site room temperature controller (switched 230 V input)</li> <li>Ⓓ Vitotrol 100, type UTD or on-site room temperature controller (switched 230 V input)</li> <li>Ⓔ Power supply 230 V/50 Hz</li> <li>Ⓕ Open Therm connection (remote control, if installed)</li> <li>Ⓖ Outside temperature sensor (accessory)</li> <li>Ⓗ Time switch (accessory)</li> <li>Ⓙ Gas pressure switch (accessory)</li> </ul> | <ul style="list-style-type: none"> <li>Ⓛ PCB inside the control unit</li> <li>X ... Electrical interface</li> <li>3 Boiler water temperature sensor</li> <li>5 Terminal box cylinder demand (accessory)</li> <li>15 Flue gas temperature sensor</li> <li>17 Return temperature sensor</li> <li>20 Circulation pump</li> <li>33 Flow limiter</li> <li>35 Gas solenoid valve</li> <li>47 Temperature limiter</li> <li>100 Fan motor 230 V~</li> <li>100A Fan control</li> </ul> |
|---|---|

## Parts lists

### **When ordering spare parts:**

*Quote the part and serial no. (see type plate) and the item number of the required part (as per this parts list).*

*Standard parts are available from your local supplier.*

- |  |   |
|--|---|
| 001 Heat exchanger                                   | 024 Venturi extension                     |
| 002 Heating water flow connection pipe               | 025 Control unit                          |
| 003 Heating water return connection pipe             | 026 Cover, wiring chamber                 |
| 004 Gas supply pipe                                  | 027 Thermal circuit breaker               |
| 005 Boiler flue connection with gasket               | 028 Boiler water temperature sensor       |
| 006 Siphon   | 029 Flow control switch                   |
| 007 Flue gas gasket                                  | 034 Fuse 2.5 A (slow) (10 pce)            |
| 008 Boiler flue connection plug                      | 039 Wall mounting bracket                 |
| 009 Thermal insulation block                         | 040 Front panel                           |
| 010 Condensate pipe                                  | 043 Flue gas temperature sensor           |
| 011 Condensate hose                                  | 046 Air vent valve                        |
| 012 Fixing clips                                     |   |
| 013 Clip $\varnothing$ 8 (5 pce)                     | Wearing parts                             |
| 014 Burner gasket                                    | 018 Ignition and ionisation electrode     |
| 015 Thermal insulation ring                          |   |
| 016 Burner gauze assembly                            | Parts not shown                           |
| 017 Burner gauze assembly gasket                     | 023 Conversion kit G 31                   |
| 018 Ignition and ionisation electrode                | 030 Gas solenoid valve cable harness 35   |
| 019 Gasket ignition and ionisation electrode (5 pce) | 031 Fan cable harness 100                 |
| 020 Fan  | 032 Cable harness X20                     |
| 021 Gas valve  | 033 Power cable, auxiliary earth          |
| 022 Burner door                                      | 035 Cable fixing                          |
|  | 036 Spray paint, Vitowhite                |
|  | 037 Touch-up paint stick, Vitowhite       |
|  | 038 Special grease                        |
|  | 041 Installation and service instructions |
|  | 042 Operating instructions                |
|  | 044 Power cable                           |
|  | 045 Circulation pump connecting cable     |
|  | Ⓐ Type plate                              |

**Parts lists** (cont.)

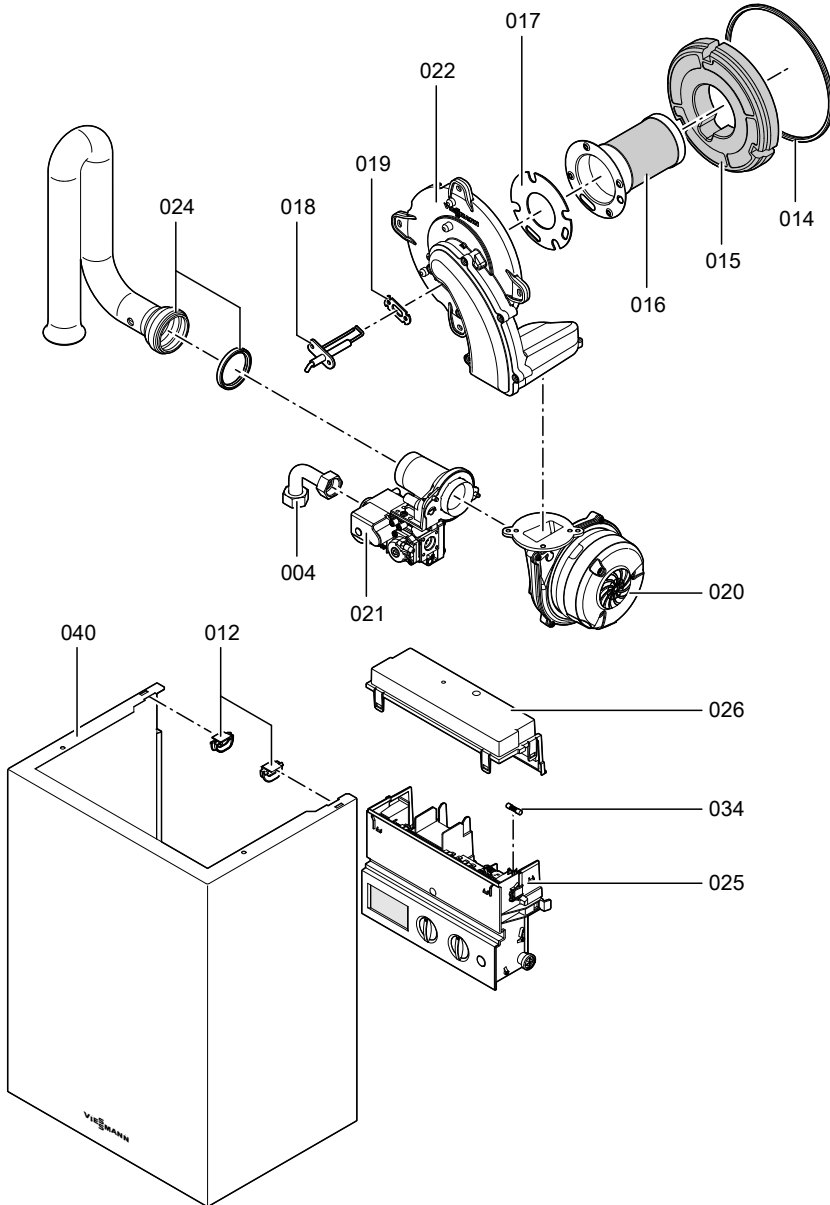

Parts lists (cont.)

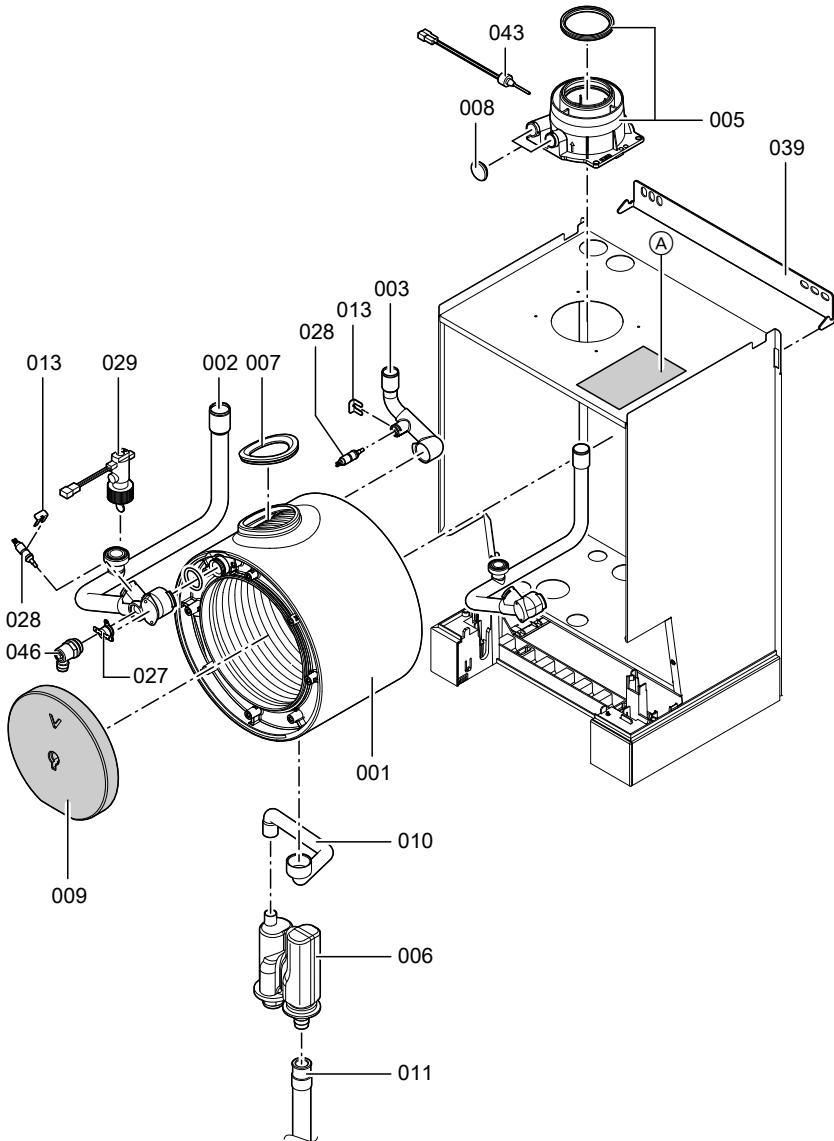

## Specification

### Specification

Rated voltage:	230 V~	Temperature limiter setting:	100 °C (fixed)
Rated frequency:	50 Hz	Backup fuse (power supply):	max. 16 A
Rated current:	2.0 A~		
Safety category:	I		
IP rating:	IP X4 to EN 60529		

Permissible ambient temperature

- during operation: 0 to +40 °C
- during storage and transport: -20 to +65 °C

<b>Rated heating output range</b>						
<b>T<sub>V</sub>/T<sub>R</sub> 50/30 °C</b>	<b>kW</b>	<b>7.9 - 13</b>	<b>7.9 - 16</b>	<b>7.9 - 19</b>	<b>7.9 - 26</b>	<b>11 - 35</b>
<b>T<sub>V</sub>/T<sub>R</sub> 80/60 °C</b>	<b>kW</b>	<b>7.2 - 11.9</b>	<b>7.2 - 14.6</b>	<b>7.2 - 17.3</b>	<b>7.2 - 23.7</b>	<b>10 - 31.9</b>
<b>Rated heat input range</b>	<b>kW</b>	<b>7.4 - 12.2</b>	<b>7.4 - 15.0</b>	<b>7.4 - 17.8</b>	<b>7.4 - 24.3</b>	<b>10.3 - 32.7</b>
<b>Connection values</b> *1						
relative to the max. load with natural gas H	m <sup>3</sup> /h	1.3	1.6	1.9	2.6	3.5
LPG P	kg/h	0.9	1.1	1.4	1.9	2.6
<b>Min. static head</b> (open vented systems)	bar	0.2	0.2	0.2	0.2	0.2
<b>Min. flow rate</b> (heating water)	l/h	200	200	200	200	200
<b>Power consumption</b> (max.)	W	45	50	55	60	65
<b>Weight without front panel</b> (installation)	kg	24	24	24	24	32
<b>Product ID</b>	C€-0085 BT 0029					

\*1 The connection values are only for documentation purposes (e.g. in the gas contract application) or to estimate a supplementary volumetric settings check. Due to the factory settings, the gas pressure must not be altered from these values. Reference: 15°C, 1013 mbar.

## Declaration of conformity

### Declaration of conformity for the Vitodens 100-W

We, Viessmann Werke GmbH&Co KG, D-35107 Allendorf, confirm as sole responsible body that the product **Vitodens 100-W** complies with the following standards:

DIN 4702-6	EN 55 014
EN 483	EN 60 335
EN 625	EN 61 000-3-2
EN 677	EN 61 000-3-3
EN 50 165	

In accordance with the following Directives, this product is designated with **CE-0085**:

90/396/EEC	2004/108/EC
92/42/EEC	2006/95/EC

This product complies with the requirements of the Efficiency Directive (92/42/EEC) for **condensing boilers**.

Allendorf, 01 December 2009

Viessmann Werke GmbH&Co KG



Authorised signatory Manfred Sommer

## Keyword index

### B

Boiler water temperature sensor.....	39
Burner gasket.....	25
Burner gauze assembly.....	25
Burner installation.....	28
Burner removal.....	24

### C

Checking volumetric flow rate.....	40
Combustion chamber cleaning.....	27
Commissioning.....	19
Condensate connection.....	12
Condensate drain.....	27
Connection diagram.....	49
Connections.....	10
Connections on the water side.....	10
Control unit, opening.....	14

### D

Declaration of conformity.....	55
--------------------------------	----

### E

Electrical connections.....	14
-----------------------------	----

### F

Fault code.....	32
Fault messages.....	32
Filling the system.....	19
Flue gas temperature sensor.....	41
Flue pipe.....	13
Frost limit.....	47
Frost protection.....	47
Function sequence.....	31
Fuse.....	43

### G

Gas connection.....	11
Gas supply pressure.....	22
Gas train .....	22
Gas type conversion	
■ LPG.....	21
■ Natural gas.....	44

### H

Heat exchanger cleaning.....	27
Heating curve.....	47

### I

Ignition.....	26
Ignition electrode.....	26
Ionisation electrode.....	26

### O

Outside temperature sensor .....	38
----------------------------------	----

### R

Reset.....	36
------------	----

### S

Safety chain .....	42
Siphon.....	13, 27
Spare parts.....	51
Specification .....	54
Static pressure.....	22
Supply pressure.....	21

### T

Temperature limiter.....	42
Troubleshooting.....	37

### V

Ventilation air pipe.....	13
Venting.....	20

### W

Wall mounting.....	7
Weather-compensated mode.....	47







## Applicability

**These service instructions apply for appliances with the following serial numbers (see type plate):**

7416302  
7499606

7416303

7416304

7416307

Viessmann Werke GmbH&Co KG  
D-35107 Allendorf  
Telephone: +49 6452 70-0  
Fax: +49 6452 70-2780  
[www.viessmann.com](http://www.viessmann.com)

Viessmann Limited  
Hortonwood 30, Telford  
Shropshire, TF1 7YP, GB  
Telephone: +44 1952 675000  
Fax: +44 1952 675040  
E-mail: [info-uk@viessmann.com](mailto:info-uk@viessmann.com)

5368 662 GB Subject to technical modifications.