

Installation and service instructions

for contractors

VIESSMANN

Vitodens 100-W

Type **WB1B**, 7.9 to 26.0 kW

Wall mounted gas fired condensing boiler

Natural gas and LPG version

Gas council no.: 41-819-21; 41-819-22; 41-819-23; 41-819-24



VITODENS 100-W



Safety instructions



Please follow these safety instructions closely to prevent accidents and material losses.

Safety instructions explained



Danger

This symbol warns against the risk of injury.



Please note

This symbol warns against the risk of material losses and environmental pollution.

Note

Details identified by the word "Note" contain additional information.

Target group

These instructions are exclusively designed for qualified personnel.

- Work on gas equipment must only be carried out by a qualified gas fitter.
- Work on electrical equipment must only be carried out by a qualified electrician.
- The system must be commissioned by the system installer or a qualified person authorised by the installer.

Regulations

Observe the following when working on this system

- all legal instructions regarding the prevention of accidents,
- all legal instructions regarding environmental protection,
- the Code of Practice of relevant trade associations,

- all current safety regulations as defined by DIN, EN, DVGW, TRGI, TRF, VDE and all locally applicable standards,
- Gas Safety (Installation & Use) Regulations
 - the appropriate Building Regulation either the Building regulations, the Building Regulation (Scotland), Building Regulations (Northern Ireland),
 - the Water Fittings Regulation or Water Bylaws in Scotland,
 - the current I.E.E. Wiring Regulations.

If you smell gas



Danger

Escaping gas can lead to explosions which may result in serious injury.

- Never smoke. Prevent naked flames and sparks. Never switch lights or electrical appliances ON or OFF.
- Close the gas shut-off valve.
- Open windows and doors.
- Remove all people from the danger zone.
- Notify your gas or electricity supplier from outside the building.
- Shut off the electricity supply to the building from a safe place (outside the building).

Safety instructions (cont.)

If you smell flue gas



Danger

Flue gas can lead to life-threatening poisoning.

- Shut down the heating system.
- Ventilate the boiler room.
- Close all doors leading to the living space.

Working on the system

- When using gas as fuel, also close the main gas shut-off valve and safeguard against unauthorised reopening.
- Isolate the system from the power supply and check that it is no longer 'live', e.g. by removing a separate fuse or by means of a main isolator.
- Safeguard the system against unauthorised reconnection.



Please note

Electronic modules can be damaged by electro-static discharges. Touch earthed objects, such as heating or water pipes, to discharge static loads.

Repair work



Please note

Repairing components which fulfil a safety function can compromise the safe operation of your heating system.

Replace faulty components only with original Viessmann spare parts.

Ancillary components, spare and wearing parts



Please note

Spare and wearing parts which have not been tested together with the heating system can compromise its function. Installing non-authorised components and non-approved modifications/conversion can compromise safety and may invalidate our warranty. For replacements, use only original spare parts from Viessmann or those which are approved by Viessmann.

Index

Installation instructions

Preparing for installation

Product information.....	5
Preparing for installation.....	5

Installation sequence

Installing the boiler and making all connections.....	8
Opening the control unit casing.....	11
Electrical connections.....	12

Service instructions

Commissioning, inspection, maintenance

Steps - commissioning, inspection and maintenance.....	15
Further details regarding the individual steps.....	16

Troubleshooting

Function sequence and possible faults.....	26
Fault messages on the display.....	27
Repairs.....	31

Gas type conversion

Converting from LPG to natural gas.....	37
---	----

Control unit

Functions and operating conditions in weather-compensated mode.....	39
---	----

Designs

Connection and wiring diagram.....	40
------------------------------------	----

Parts lists.....	42
------------------	----

Specification.....	45
--------------------	----

Certificates

Declaration of conformity.....	46
--------------------------------	----

Keyword index.....	47
--------------------	----

Product information

Vitodens 100-W, WB1B

Set up for operation with natural gas.

Preparing for installation

Preparing the boiler installation

Dimensions and connections

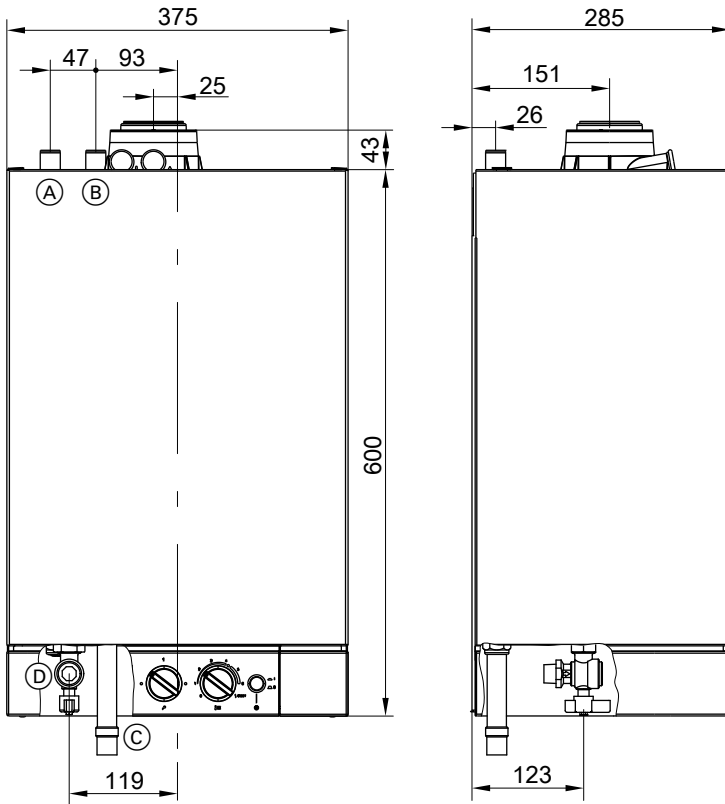

- Ⓐ Heating flow
- Ⓑ Heating return

- Ⓒ Condensate drain: Plastic pipe \varnothing 22 mm



Preparing for installation (cont.)

- Ⓓ Gas connection, 1/2" male iron

Fitting the wall retainer

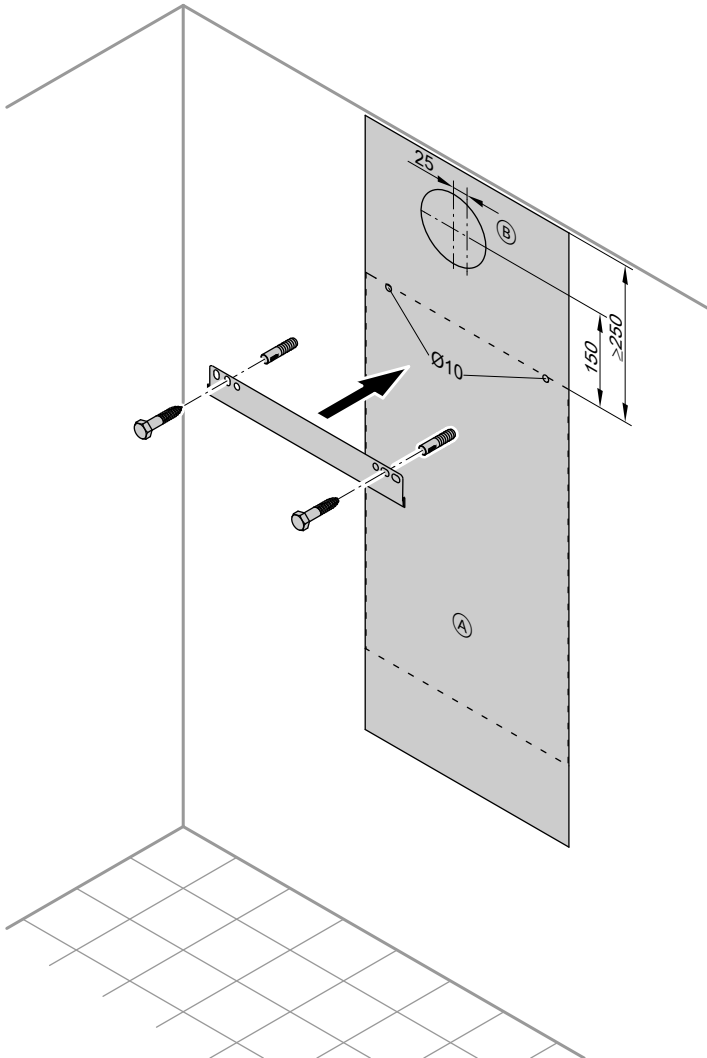

Ⓐ Vitodens installation template

Ⓑ Opening for the balanced flue

Preparing for installation (cont.)

1. Position the installation template provided on the wall.
2. Mark out the rawl plug holes.
3. Drill $\varnothing 10$ mm holes and insert the rawl plugs provided.
4. Secure wall retainer with screws provided.
2. Prepare gas connection.
3. Prepare the electrical connections. Observe valid IEEE standards.
 - A 1.5 m long power cable is fitted as standard.
 - Accessory cables:
NYM-O two-core min. 0.5 mm².

Preparing the connections

1. Prepare the water connections. Flush the heating system.

Installing the boiler and making all connections

Removing the front panel and mounting the boiler

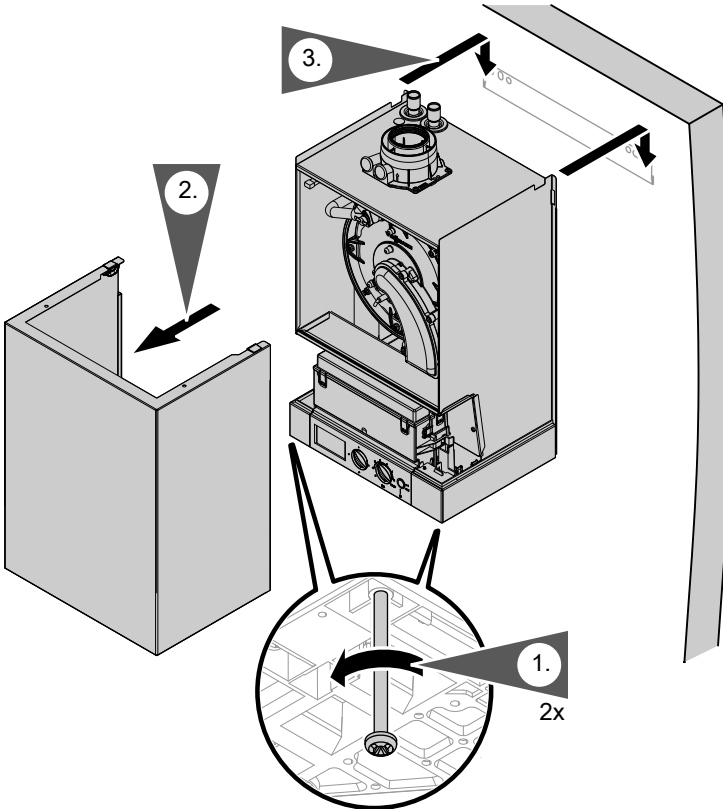

1. Release screws at the bottom of the boiler; do not remove completely.
2. Remove front panel.
3. Hook the boiler into the wall retainer.

Installing the boiler and making all connections (cont.)

Installing connections on the water side

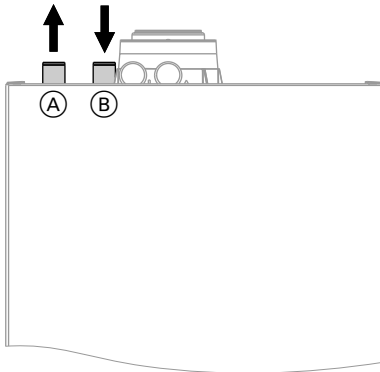

Ⓐ Heating flow

Ⓑ Heating return

Gas connection

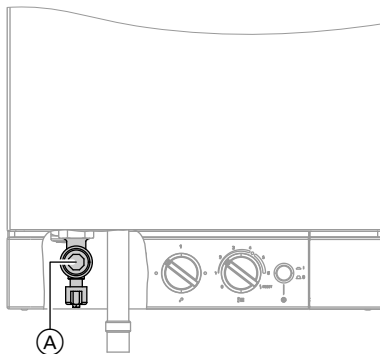

1. Connect gas shut-off valve to connection Ⓐ.
2. Carry out a tightness test.



Please note

Excessive test pressure may damage the boiler and gas valve.

Max. test pressure 150 mbar. Where higher pressure is required for tightness tests, separate the boiler and gas valves from the gas supply pipe (undo the fitting).

3. Vent the gas line.

Installing the boiler and making all connections (cont.)

Condensate connection

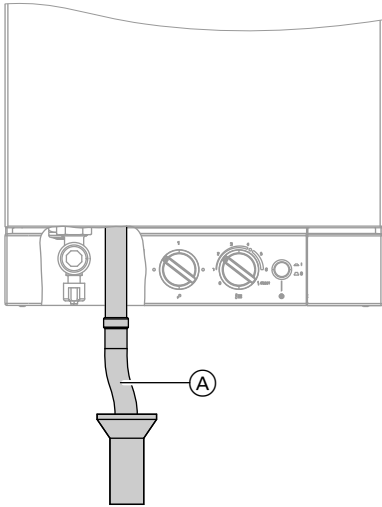

Connect condensate drain (A) with a slope and pipe vent to the public sewer. Observe the local waste water regulations.

Note

Fill the siphon with water before commissioning.

Filling the siphon with water

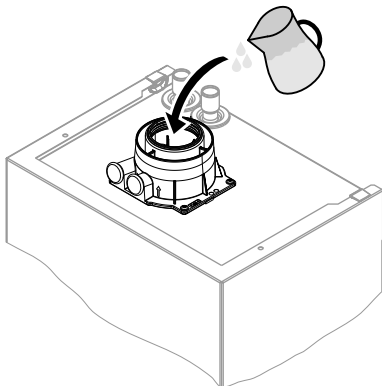

Fill the flue gas connection with a minimum of 0.3 l of water.



Please note

During commissioning, flue gas may be emitted from the condensate drain.

Fill the siphon with water immediately prior to commissioning.

Installing the boiler and making all connections (cont.)

Balanced flue connection

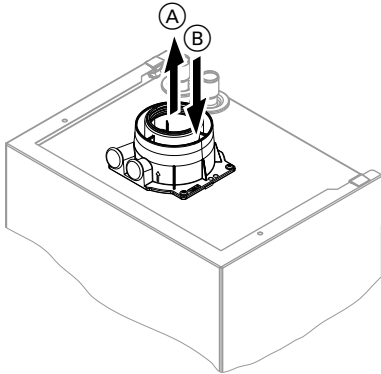

- (A) Flue gas
- (B) Ventilation air

Connect the balanced flue.
During installation and positioning of the flue system, observe building regulations part L, J and BS 5440 Part 1 and 2.



Flue system installation instructions.

Opening the control unit casing



Please note

Electronic modules can be damaged by electrostatic discharge. Before beginning work, touch earthed objects, such as heating or water pipes, to discharge static loads.

Opening the control unit casing (cont.)

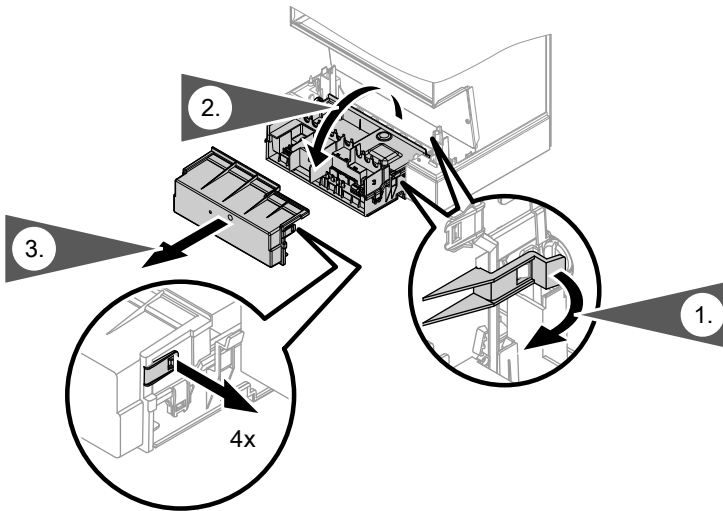

Electrical connections



Information regarding the connection of accessories

For connection of accessories, observe the separate installation instructions provided with the accessories.

Electrical connections (cont.)

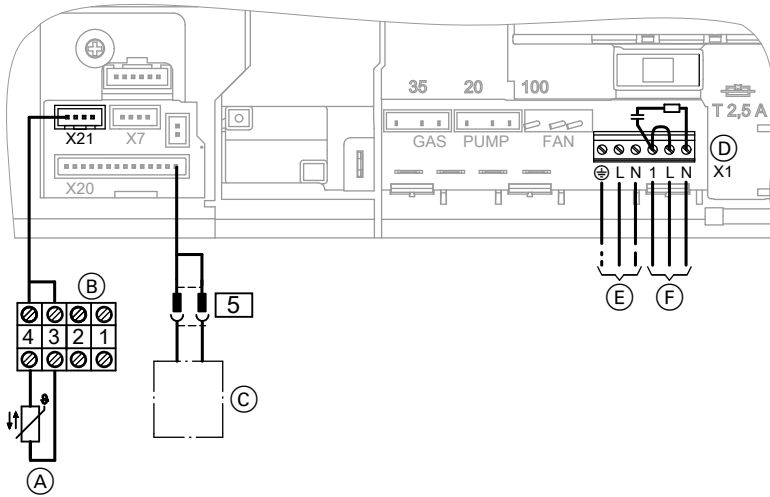

Note

Pump can be connected externally of the boiler through the external terminal box

- (A) Only for weather-compensated mode:
Outside temperature sensor (accessory)
- (B) Lead (accessory)
- (C) Terminal box cylinder demand (accessory; see separate installation instructions)
- (D) Jumper (remove when connecting a room thermostat or switched live for 'Y' or 'S' Plan installation)

- (E) Power supply (230 V, 50 Hz).



Danger

Incorrect wire allocation can cause severe injuries and damage to the equipment. Take care not to interchange wires "L1" and "N".

The power supply must be equipped with a neutral conductor. Water pipes should be connected to the earth bonding of the house in question.

- (F) Vitotrol 100 (room thermostat) or on-site room temperature controller



Separate installation instructions

or
Input for Y-plan or S-plan heating systems

Electrical connections (cont.)

Outside temperature sensor (accessory)

1. Plug the lead supplied with the outside temperature sensor into socket "X21".
2. Connect the outside temperature sensor to terminals 3 and 4.

Routing leads and closing control unit casing

- !** **Please note**
Leads will be damaged if they come into contact with hot parts. When routing and securing leads on site, ensure that the maximum permissible temperatures for these cables are not exceeded.

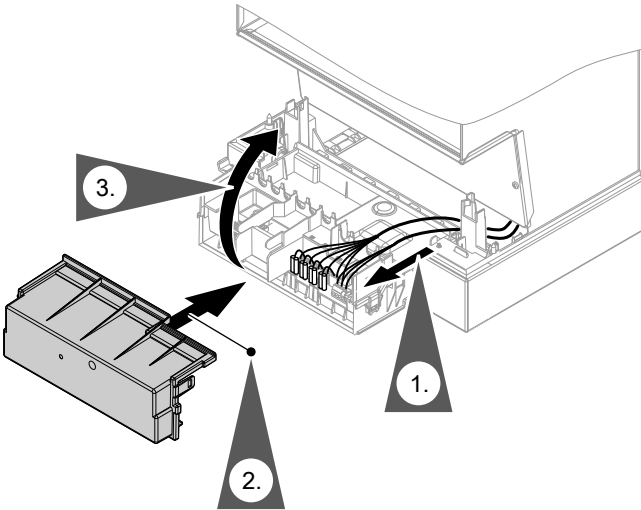

Further details regarding the individual steps

Filling the heating system



Please note

- Unsuitable fill water increases the level of deposits and corrosion and may lead to boiler damage.
 - Thoroughly flush the heating system prior to filling it with water.
 - Only use fill water of potable quality.
 - Soften fill water harder than 300 ppm.
 - An antifreeze additive suitable for heating systems can be mixed with the fill water.

Fill and vent heating system.

Converting to operation with LPG

In the delivered condition, the boiler is set up for operation with natural gas. For operation with LPG, the gas nozzle must be changed and the gas type converted in the control unit.

Changing from LPG to natural gas - see page 37.



Separate installation instructions.

Further details regarding the individual steps (cont.)

Checking and adjusting the ignition and ionisation electrodes

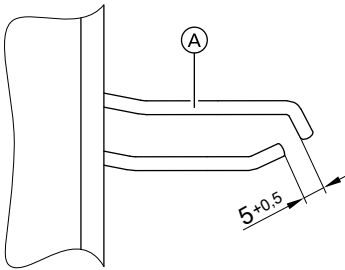
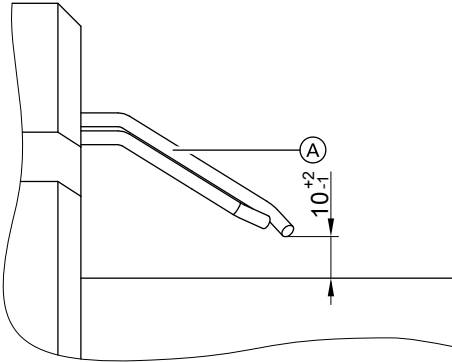

Ⓐ Ignition and ionisation electrode

Check the electrode for wear and contamination
Clean the electrode with a small brush (not with a wire brush) or emery paper.

Check all clearances. If the gaps are not as specified or the electrode is damaged, replace and align the electrode together with new gaskets. Tighten the electrode fixing screws. (2.5 Nm approx.).

Further details regarding the individual steps (cont.)

Checking the CO₂ or O₂ content

Vitodens 100-W is factory-set for natural gas. During commissioning or maintenance, the CO₂ and CO have to be measured at the boiler flue adaptor test point to check the flue integrity. Subject to the Wobbe index, the CO₂ content fluctuates between 7.4 % and 10.5 %. And CO of up to 500 ppm is acceptable.

We recommend to measure O₂ as the value is unmistakable regarding lambda (air/gas). The O₂-content fluctuates between 7.5 % and 3.2 %. Or alternatively CO/CO₂ ratio has to be less than 0.004.

If the actual CO₂ or O₂ and CO values deviate from the stated range, check the balanced flue systems for leaks. If flue installation is o.k., change the gas valve.

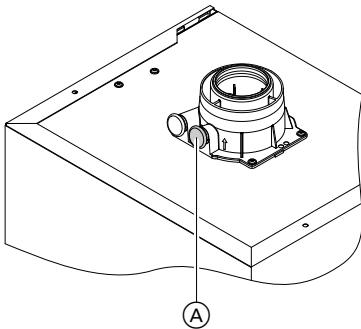

1. Connect a flue gas analyser at flue gas port (A) on the boiler flue connection.
2. Start the boiler.

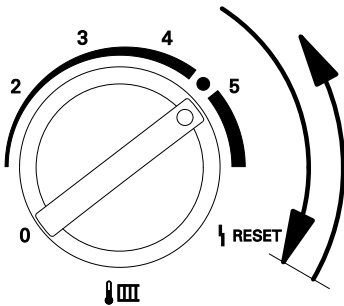

3. Turn rotary selector "🌡️ IIII" clockwise for less than 2 s and then anticlockwise back to the control range on the right. The display shows "**SERV**" and the boiler water temperature is shown.

Further details regarding the individual steps (cont.)

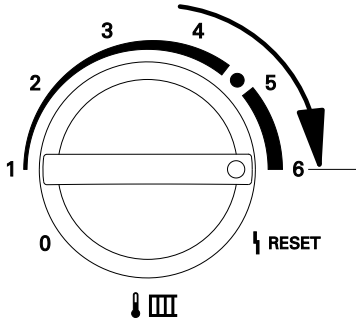

4. Adjust the upper output:
Turn rotary selector "🌡️ IIII" to the control range on the right.
The display shows 5 bars for upper output.

5. Measure the CO₂ content for upper output.
The CO₂ content must be between 7.4 and 10.5 %.

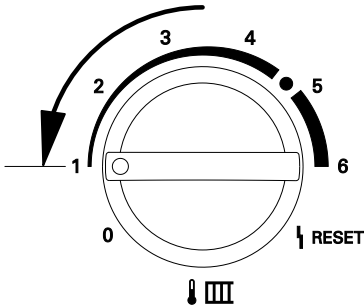

6. Adjust the lower output:
Turn rotary selector "🌡️ IIII" to the left control range.
The display shows 1 bar for lower output.

7. Test the CO₂ content for lower output.
The CO₂ content must be between 7.4 and 10.5 %.

8. If the CO₂ content is **not** within the given range, check the flue gas/ventilation air system for tightness.
Remedy any leaks.

9. Shut the boiler down, remove flue gas analyser and close flue gas port (A).

Further details regarding the individual steps (cont.)

Burner removal

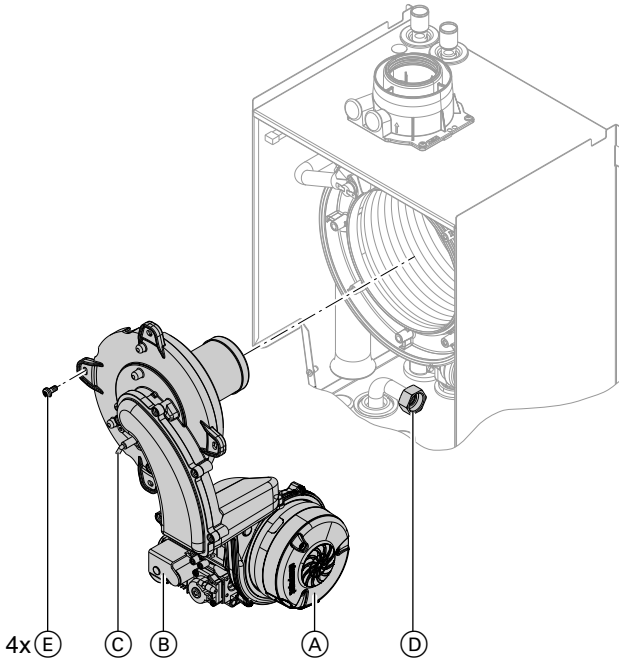

1. Switch OFF the power.
2. Shut off the gas supply.
3. Disconnect electrical cables from fan motor (A), gas valve (B).
4. Open control unit casing (see page 11) and pull out the lead to ignition electrode (C).
5. Disconnect the venturi extension from fan (A).
6. Disconnect gas supply pipe (D) fitting.
7. Undo four screws (E) and remove the burner.



Please note

To prevent damage, never rest the burner on the gauze assembly.

Further details regarding the individual steps (cont.)

Checking and adjusting electrodes

1. Check the electrode for wear and contamination.
2. Clean the electrode with a small brush (not with a wire brush) or emery paper.
3. Check the electrode gaps. If the gaps are not as specified or the electrode is damaged, replace and align the electrode together with a new gasket. Tighten the electrode fixing screws with 3.5 Nm.

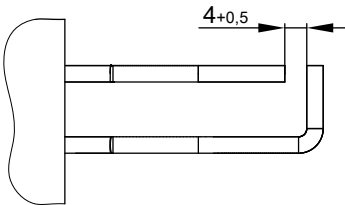
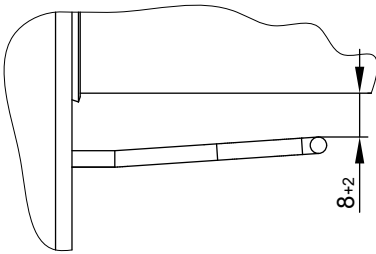

Cleaning the heat exchanger



Please note

Scratches on parts that come into contact with flue gas can lead to corrosion.

Never use brushes to clean the heat exchanger.

Further details regarding the individual steps (cont.)

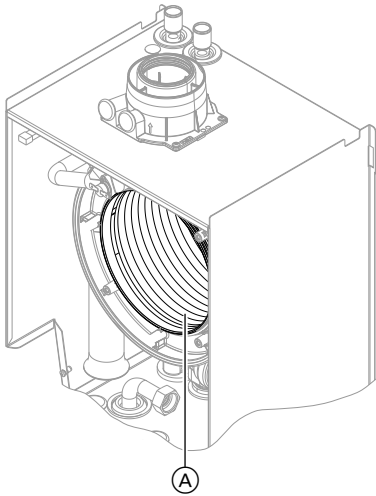

1. Use a vacuum cleaner to remove residues from heat exchanger (A) inside the combustion chamber.
2. If required, spray slightly acidic, chloride-free cleaning agents based on phosphoric acid onto heat exchanger (A) and let the solution soak in for approx. 20 min.
3. Thoroughly flush heat exchanger (A) with water.

Checking the condensate drain and cleaning the siphon

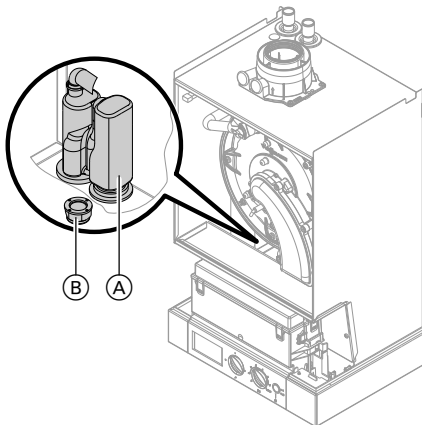

1. Check at siphon (A) that the condensate can drain freely.
2. Place an appropriate container under siphon (A).
3. Remove locking cap (B) and drain the contents of siphon (A) into the container.
4. Replace locking cap (B) with gasket.
5. Fill siphon (A) with water by pouring about 0.3 l of water into the combustion chamber.

Further details regarding the individual steps (cont.)

Burner installation

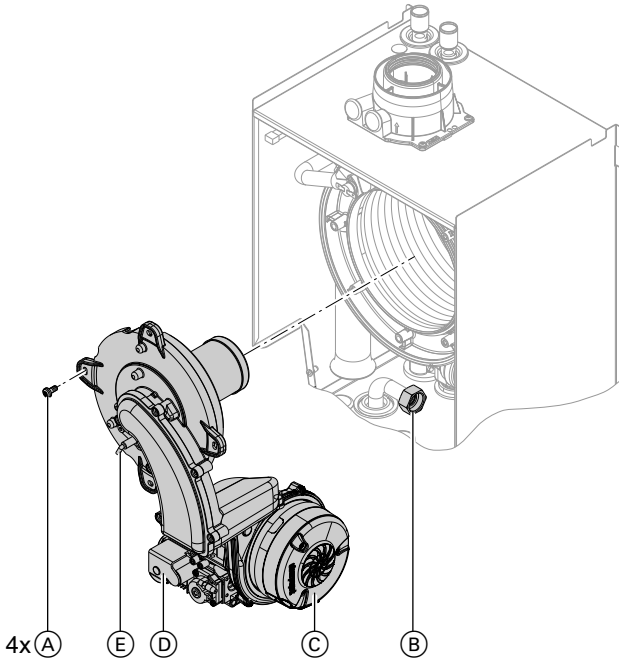

1. Fit the burner and torque screws (A) diagonally with 4.0 Nm.
2. Insert new gasket and tighten the fittings on gas supply pipe (B).
3. Push the venturi extension on to fan (C).
4. Attach electrical cables to fan motor (C) and gas valve (D).
5. Push ignition electrode cable (E) into the control unit and close the control unit casing.
6. Reopen gas supply and switch on power supply.
7. Check the gas connections for tightness.



Danger

Escaping gas leads to a risk of explosion.
Check all fittings for gas tightness.

Further details regarding the individual steps (cont.)

Checking gas equipment for tightness at operating pressure



Danger

Escaping gas leads to a risk of explosion.
Check gas equipment for tightness.

Fitting the front panel

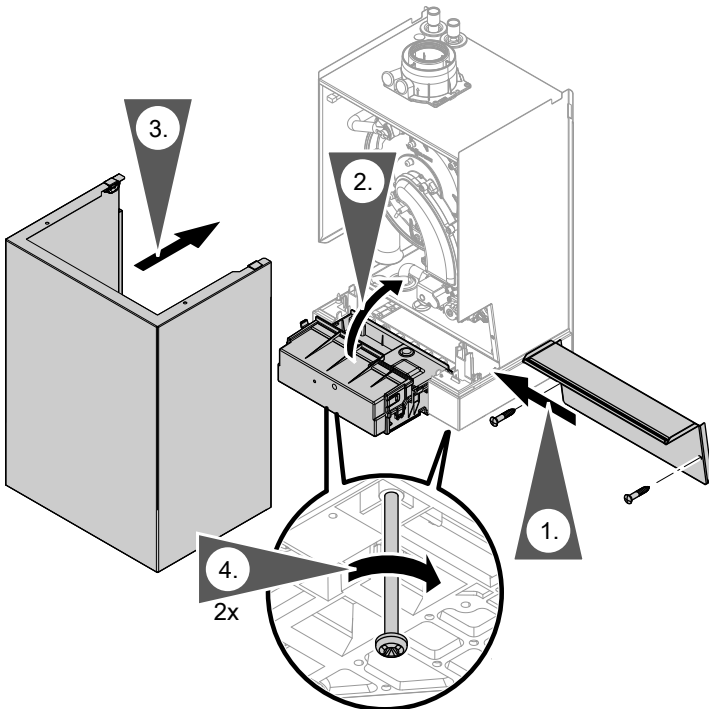

Instructing the system user

The system installer must hand the operating instructions to the system user and instruct him/her in the operation of the system.

Function sequence and possible faults

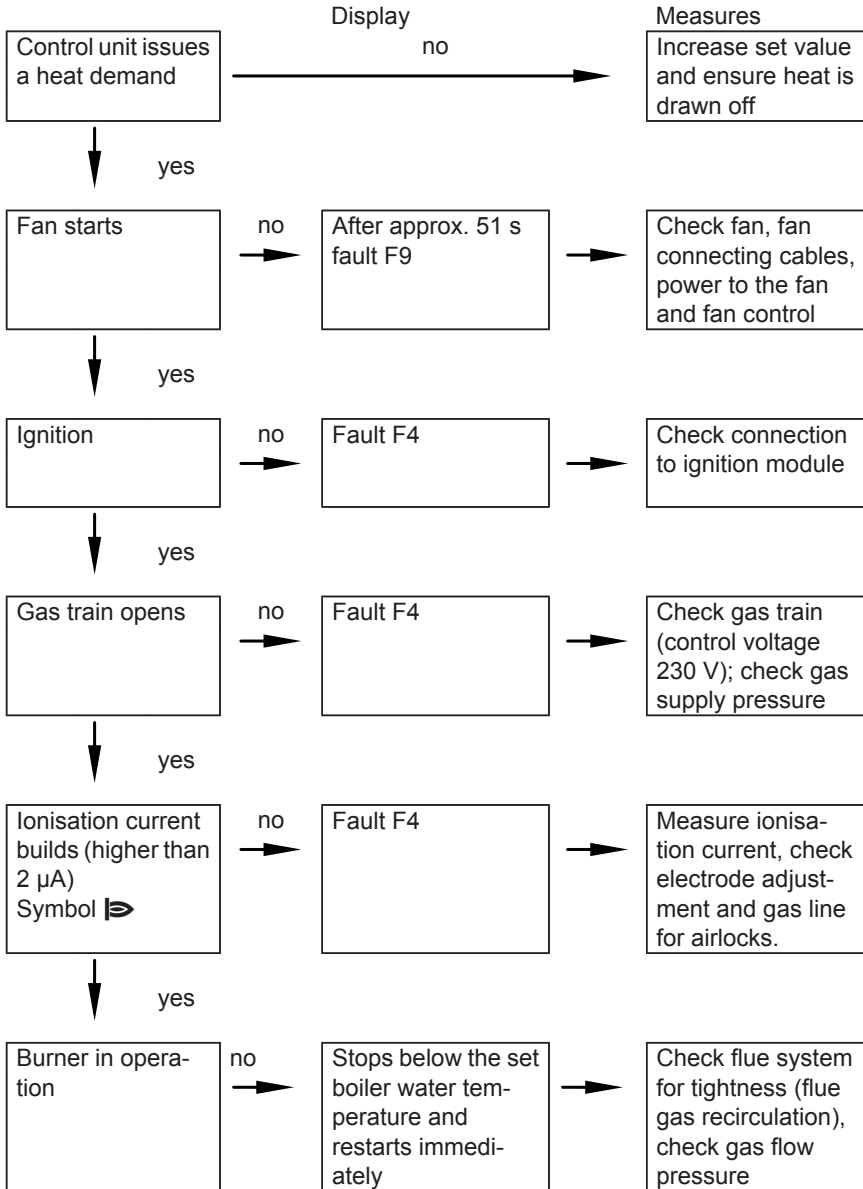

Fault messages on the display

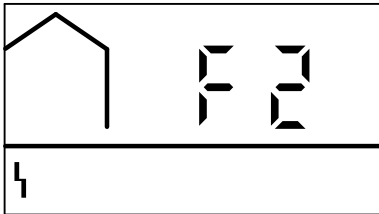

Faults are indicated by a flashing fault code with fault symbol "F" on the display.

For fault code explanations see the following table.

- Flashing fault symbol "F": To reset press "F RESET" (see page 30) after the fault has been remedied
- Constantly displayed fault symbol "F": Will automatically reset after the fault is remedied

Fault code on display	System characteristics	Cause	Measures
10	Constant mode	Short circuit, outside temperature sensor	Check outside temperature sensor and lead (see page 31).
18	Constant mode	Outside temperature sensor lead broken	Check outside temperature sensor and lead (see page 31).
30	Burner switched off	Short circuit, boiler water temperature sensor	Check boiler water temperature sensor (see page 33).
38	Burner switched off	Boiler water temperature sensor lead broken	Check boiler water temperature sensor (see page 33).
50	No DHW heating	Terminal box cylinder demand fault	Check terminal box connections and replace terminal box if required.
58	No DHW heating	Terminal box cylinder demand fault	Check terminal box connections and replace terminal box if required.
60	Burner switched off	Short circuit, return temperature sensor	Check return temperature sensor (see page 33).
68	Burner switched off	Return temperature sensor lead broken	Check return temperature sensor (see page 33).
A9	Control mode without Open Therm device	Communication fault Open Therm device	Check connections and lead; replace Open Therm device if required.

Fault messages on the display (cont.)

Fault code on display	System characteristics	Cause	Measures
b0	Burner switched off	Short circuit, flue gas temperature sensor	Check sensor (see page 34).
b8	Burner switched off	Flue gas temperature sensor lead broken	Check sensor (see page 34).
E5	Burner switched off	Internal fault	Check ionisation electrode and connecting leads. Press "Reset" (see page 30).
F0	Burner switched off	Internal fault	Replace control unit.
F1	Burner in a fault state	Max. flue gas temperature exceeded	Check heating system fill level. Check circulation pump. Vent system. Press "Reset" (see page 30).
F2	Burner in a fault state	Temperature limiter has responded	Check heating system fill level. Check circulation pump. Vent system. Check temperature limiter and connecting leads. Press "Reset" (see page 30).
F3	Burner in a fault state	Flame signal is already present at burner start	Check ionisation electrode and connecting lead. Press "Reset" (see page 30).
F4	Burner in a fault state	No flame signal is present	Check ignition/ionisation electrode and connecting leads, check gas pressure, check gas train, ignition, ignition module and condensate drain. Press "Reset" (see page 30).

Fault messages on the display (cont.)

Fault code on display	System characteristics	Cause	Measures
F8	Burner in a fault state	Fuel valve closes too late	Check gas train. Check both control paths. Press "Reset" (see page 30).
F9	Burner in a fault state	Fan speed too low during burner start	Check fan, check fan connecting cables and power supply, check fan control. Press "Reset" (see page 30).
FA	Burner in a fault state	Fan not at standstill	Check fan, fan connecting cables and fan control. Press "Reset" (see page 30).
FC	Burner blocked	Electrical fan control (control unit) faulty	Check fan connecting cables and replace if required, or replace control unit
Fd	Burner blocked	Burner control unit fault	Check ignition electrodes and connecting cables. Check whether a strong interference (EMC) field exists near the appliance. Press "Reset" (see page 30). Replace control unit if fault persists.
FF	Burner blocked	Burner control unit fault	Check ignition electrodes and connecting cables. Check whether a strong interference (EMC) field exists near the appliance. Press "Reset" (see page 30). Replace control unit if fault persists.

Fault messages on the display (cont.)

Press reset

Note

Only press RESET if fault symbol "I" is **flashing**.

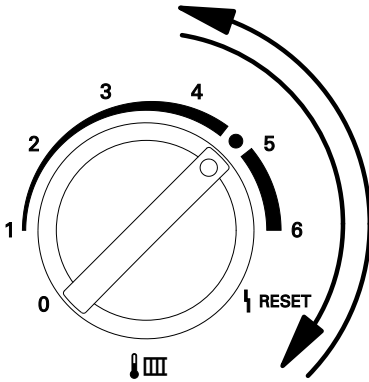

Turn rotary selector "III I" to "I
RESET" in under 2 s, then back to the control range.

Repairs

Removing front panel and pivoting control unit downwards

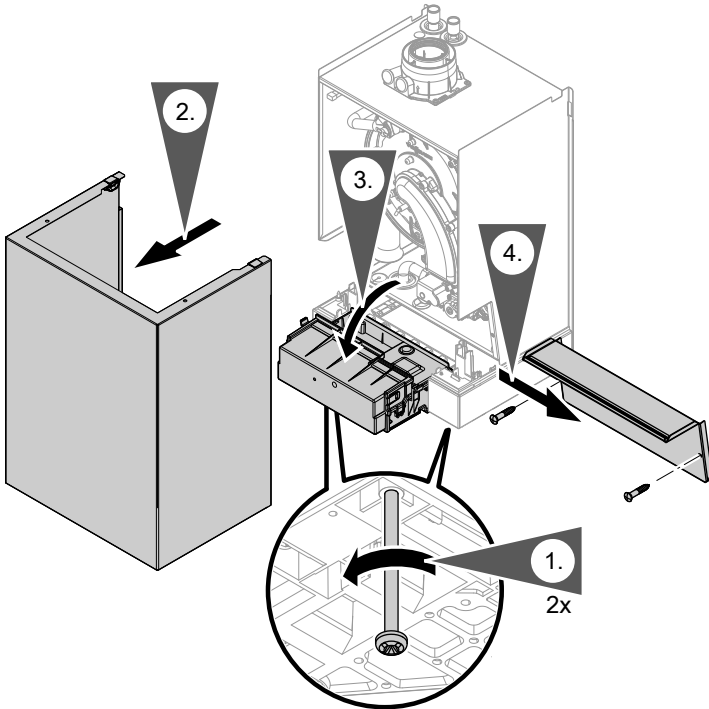

Outside temperature sensor

Note

The outside temperature sensor can only be connected if

- a) the boiler does heating only
- b) the boiler serves heating and hot water a separate switched live connection from the DHW programmer has to be connected to the boiler (see separate instructions control box)

Repairs (cont.)

1. Open the control unit casing. See page 11.
2. Disconnect outside temperature sensor leads.

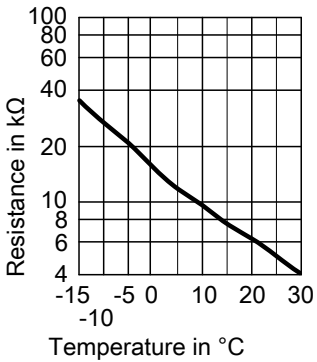
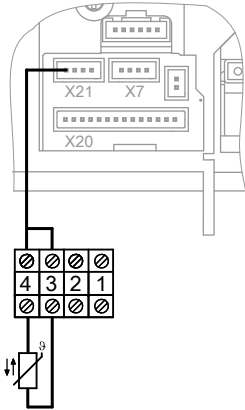

3. Check the sensor resistance and compare it with the curve.
4. Replace the sensor if the resistance varies significantly from the figure shown.

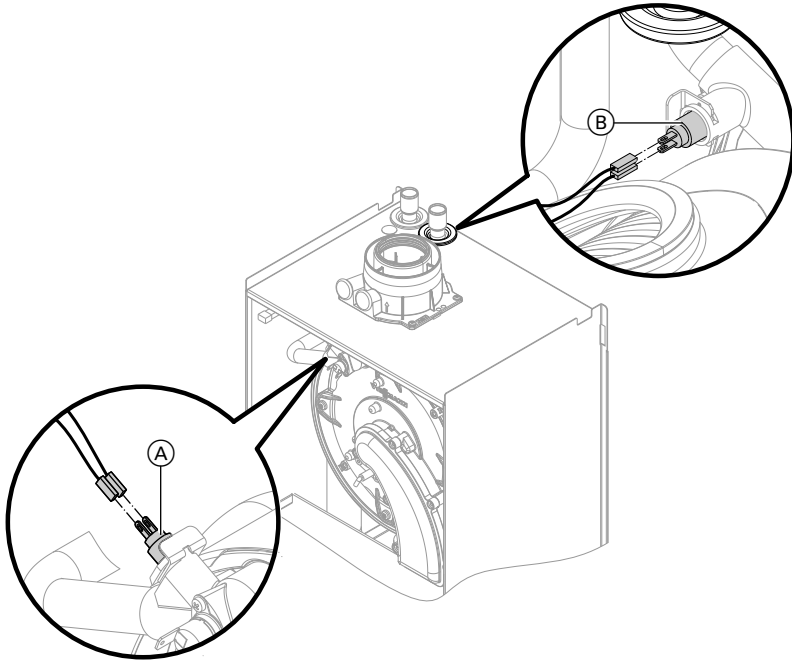
Repairs (cont.)**Checking the boiler water temperature sensor and return temperature sensor**

1. Pull the leads from boiler water temperature sensor (A) or return temperature sensor (B) and check the resistance.

Repairs (cont.)

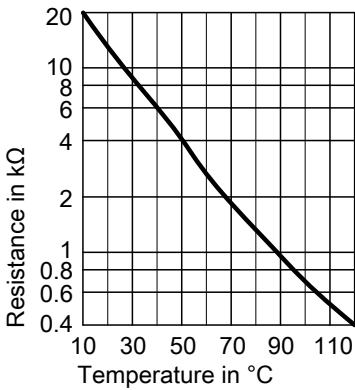

2. Check the sensor resistance and compare it with the curve.
3. If the resistance varies significantly from the figure shown, drain boiler on the heating water side and replace the sensor.



Danger

The boiler water temperature sensor is immersed in the heating water (risk of scalding).

Drain the boiler before replacing the sensor.

Checking the flue gas temperature sensor

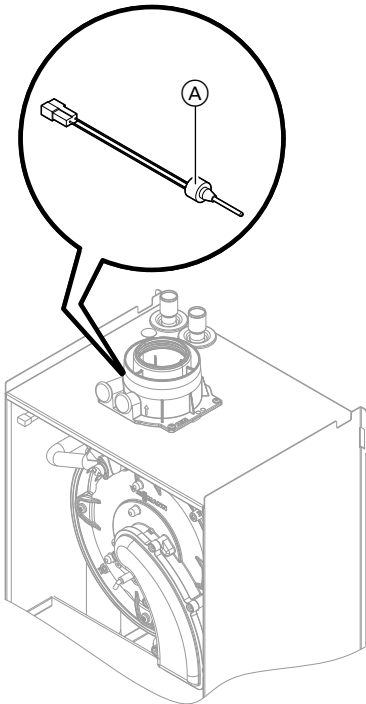

1. Pull the leads from flue gas temperature sensor (A) and check the resistance.

Repairs (cont.)

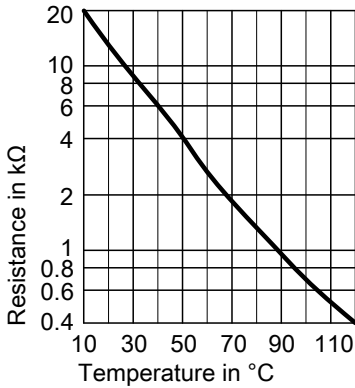

2. Check the sensor resistance and compare it with the curve.
3. Replace the sensor if the resistance varies significantly from the figure shown.

Checking the temperature limiter

If the burner control unit cannot be reset after a fault shutdown, although the boiler water temperature is below approx. 95 °C, check the temperature limiter.

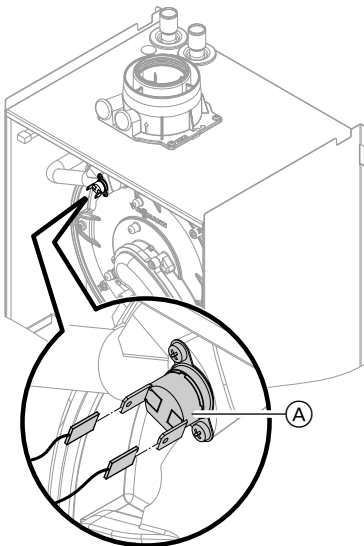

1. Pull the leads from temperature limiter (A).
2. Check the continuity of the temperature limiter with a multimeter.
3. Remove the faulty temperature limiter.
4. Install a new temperature limiter.
5. Press "Reset" on the control unit (see page 30).

Checking the fuse

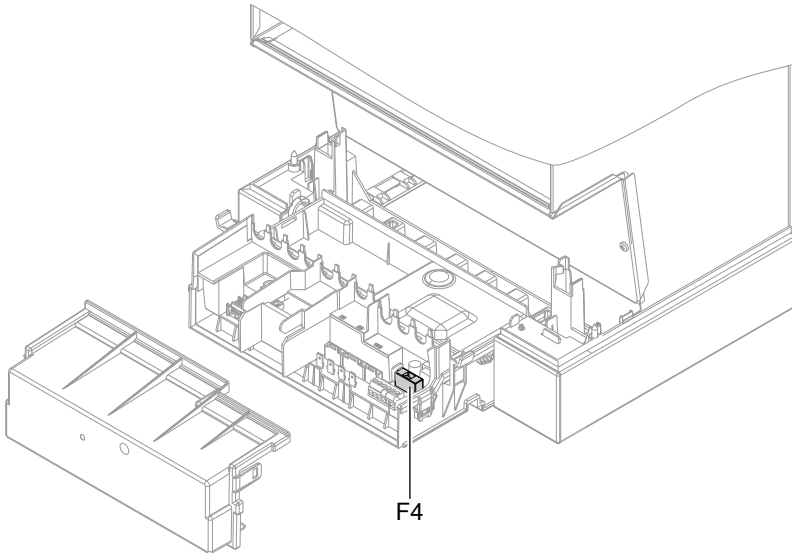

1. Switch OFF the power.
2. Open control unit casing (see page 11).
3. Check fuse F4.

Converting from LPG to natural gas

Removing gas restrictor

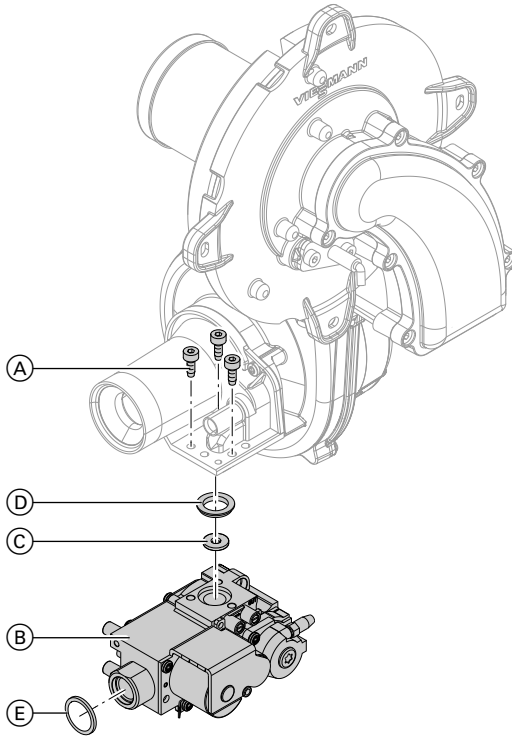

1. Remove the burner (see page 20).
2. Undo three screws (A) and remove gas train (B).
3. Remove gas restrictor (C) (if fitted) from gas train (B) and insert new gas restrictor (C) into gas train (B).
4. Fit gas train (B) with a new gasket (D).
Fixing screw torque (A): 3 Nm.
5. Refit the burner with a new gasket (E).
Union nut torque: 22 Nm.

Converting gas type on the control unit

1. Turn ON/OFF switch ON.



Converting from LPG to natural gas (cont.)

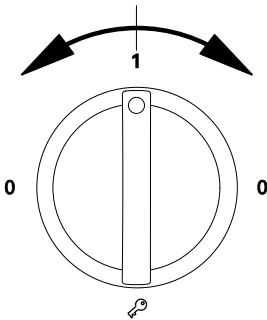
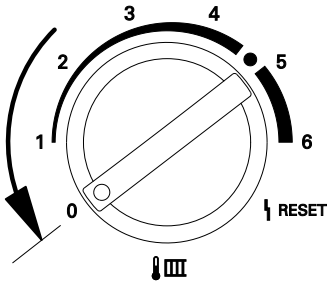
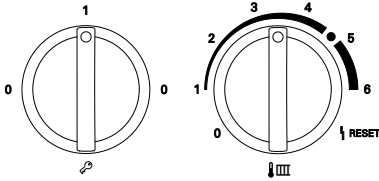

2. Simultaneously turn rotary selectors "🔥" and "🔥🔥🔥" to their central position.

"SERV" appears on the display.

3. Turn rotary selector "🔥🔥🔥" anticlockwise as far as it will go within 2 s. "🔥" Appears on the display and the set value flashes.

4. Adjust the control unit to natural gas or LPG by turning the left rotary selector "🔥".

The display shows:

- "0" for operation with natural gas
or
- "1" for operation with LPG.

5. Do **not** adjust the rotary selectors for 15 s. The set operating mode is then saved and the control unit returns to standard mode.

6. Switch ON/OFF switch off and on again. The selected gas type is now enabled

Checking the CO₂ content

See page 18.

Functions and operating conditions in weather-compensated mode

In weather-compensated mode, the boiler water temperature is regulated subject to the outside temperature.

Heating curve of weather-compensated control unit

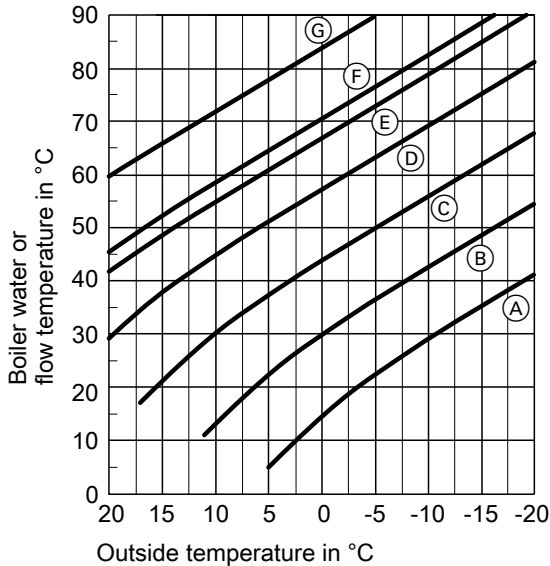

Rotary selector setting "📉📊"

- Ⓐ = 1
- Ⓑ = 2
- Ⓒ = 3
- Ⓓ = 4
- Ⓔ = Delivered condition
- Ⓕ = 5
- Ⓖ = 6

If the boiler temperature is less than 8C the circulating pump is ON and at a boiler temperature of 12C the pump is OFF. The burner will be switched on at a boiler temperature of 5°C and switched off at 15°C.

Frost protection function

The frost protection is generally active when the boiler is in 'Stand-by' mode.

Connection and wiring diagram

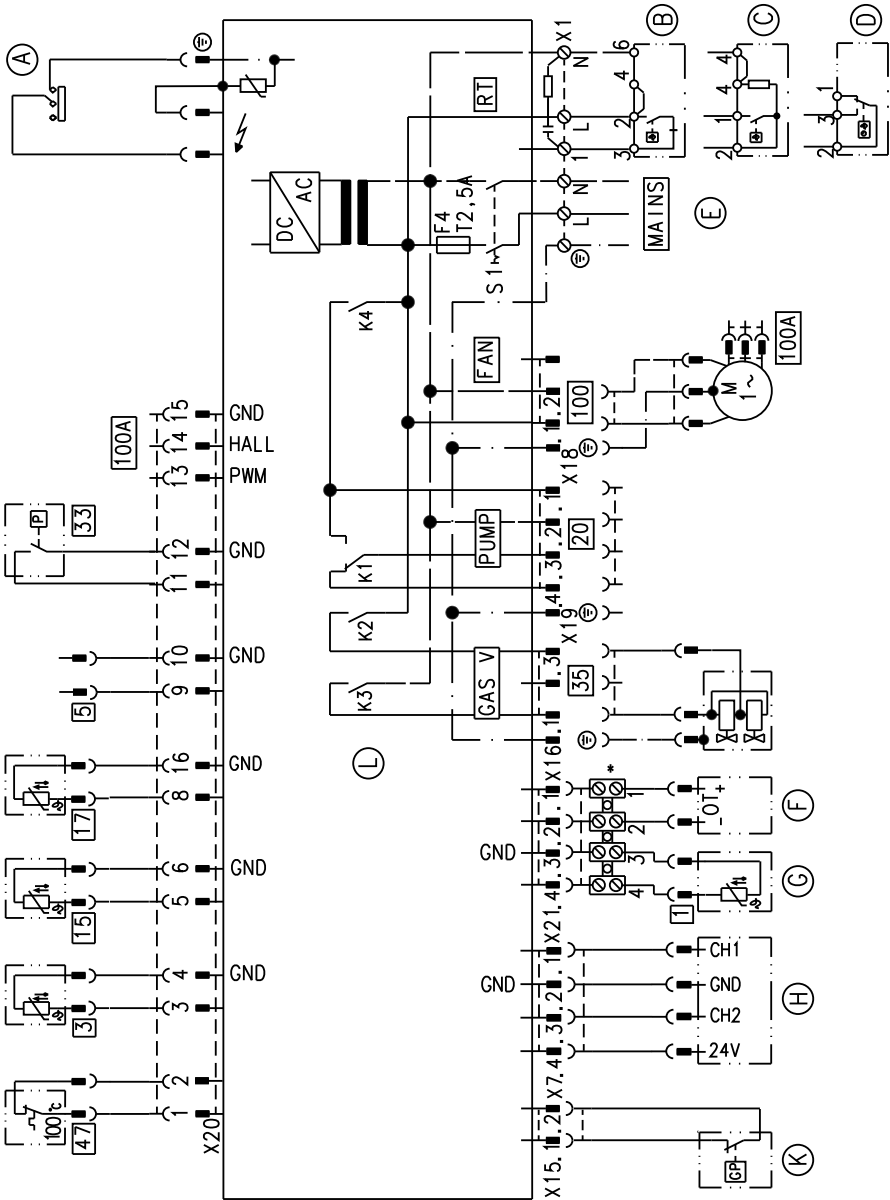

(A) Ignition/ionisation

Connection and wiring diagram (cont.)

Ⓑ	Vitotrol 100, type UTA or on-site room thermostat	Ⓛ	PCB inside the control unit
Ⓒ	Vitotrol 100, type RT or on-site room thermostat	X ...	Electrical interface
Ⓓ	Vitotrol 100, type UTD or on-site room thermostat	3	Boiler water temperature sensor
Ⓔ	Mains input 230 V/50 Hz	5	Cylinder demand terminal box (accessory)
Ⓕ	Open Therm connection (remote control)	15	Flue gas temperature sensor
Ⓖ	Outside temperature sensor (accessory)	17	Return temperature sensor
Ⓗ	Time switch (accessory)	20	Circulation pump
Ⓚ	Gas pressure limiter (accessory)	33	Flow switch
		35	Gas solenoid valve
		47	Temperature limiter
		100	Fan motor 230 V~
		100A	Fan control

Parts lists

When ordering spare parts:

Quote the part and serial no. (see type plate) and the item number of the required part (as per this parts list).

Obtain standard parts from your local supplier.

- 001 Heat exchanger
- 002 Heating water flow connection pipe
- 003 Heating water return connection pipe
- 004 Gas supply pipe
- 005 Boiler flue connection
- 006 Siphon
- 007 Flue gas gasket
- 008 Boiler flue connection plug
- 009 Thermal insulation block
- 010 Condensate pipe
- 011 Condensate hose
- 012 Fixing clips
- 013 Clip Ø 8 (5 pce.)
- 014 Burner gasket
- 015 Thermal insulation ring
- 016 Burner gauze assembly
- 017 Burner gauze assembly gasket
- 019 Gasket, ignition and ionisation electrode (5 pce.)
- 020 Fan
- 021 Gas valve

- 022 Burner door
- 024 Venturi extension
- 025 Control unit
- 026 Terminal box cover
- 027 Thermocouple
- 028 Boiler water temperature sensor
- 029 Flow control switch
- 034 Fuse 2.5 A (slow) (10 pce.)
- 039 Wall retainer
- 040 Front panel
- 043 Flue gas temperature sensor

Wearing parts

- 018 Ignition and ionisation electrode

Parts not shown

- 023 Conversion kit G 31
- 030 Gas solenoid valve cable harness 35
- 031 Fan cable harness 100
- 032 Cable harness X20
- 033 Power cable, auxiliary earth
- 035 Cable fixing
- 036 Spray paint, Vitowhite
- 037 Touch-up paint stick, Vitowhite
- 038 Special grease
- 041 Installation and service instructions
- 042 Operating instructions
- Ⓐ Type plate

Parts lists (cont.)

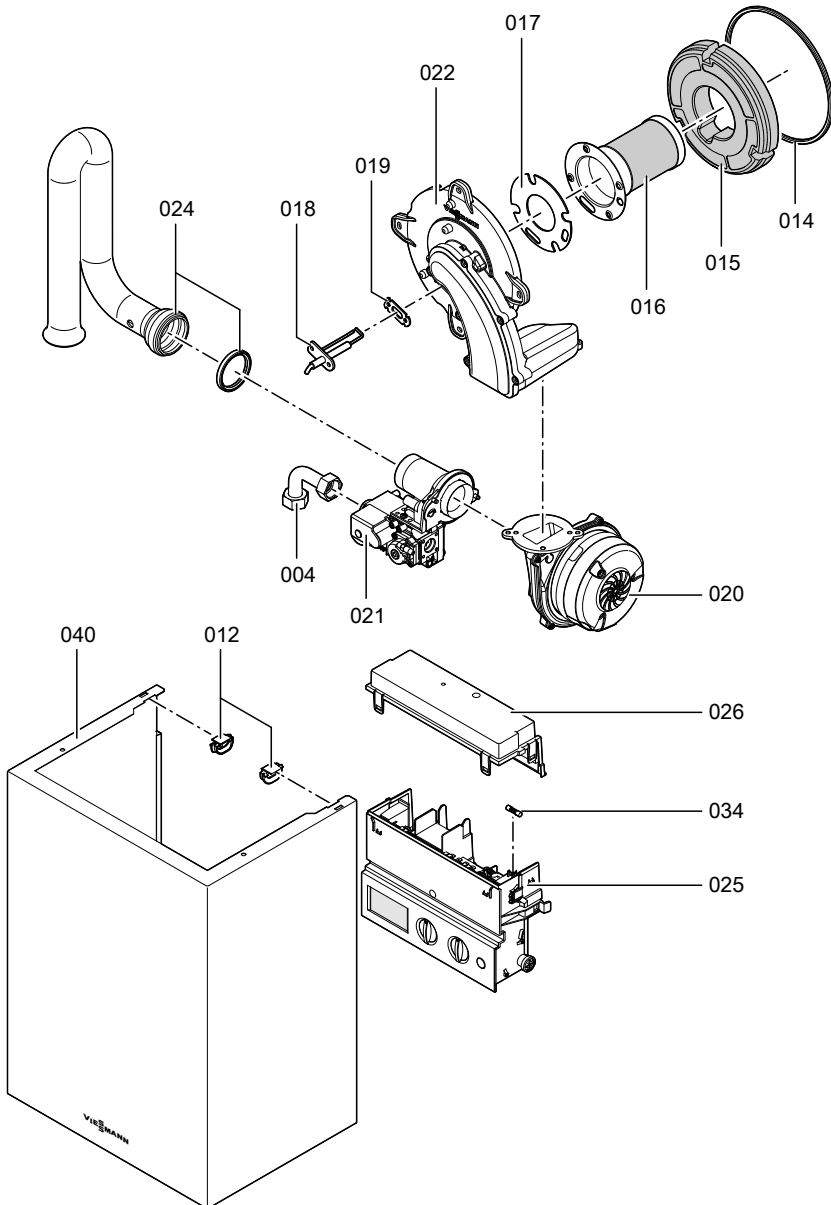

Parts lists (cont.)

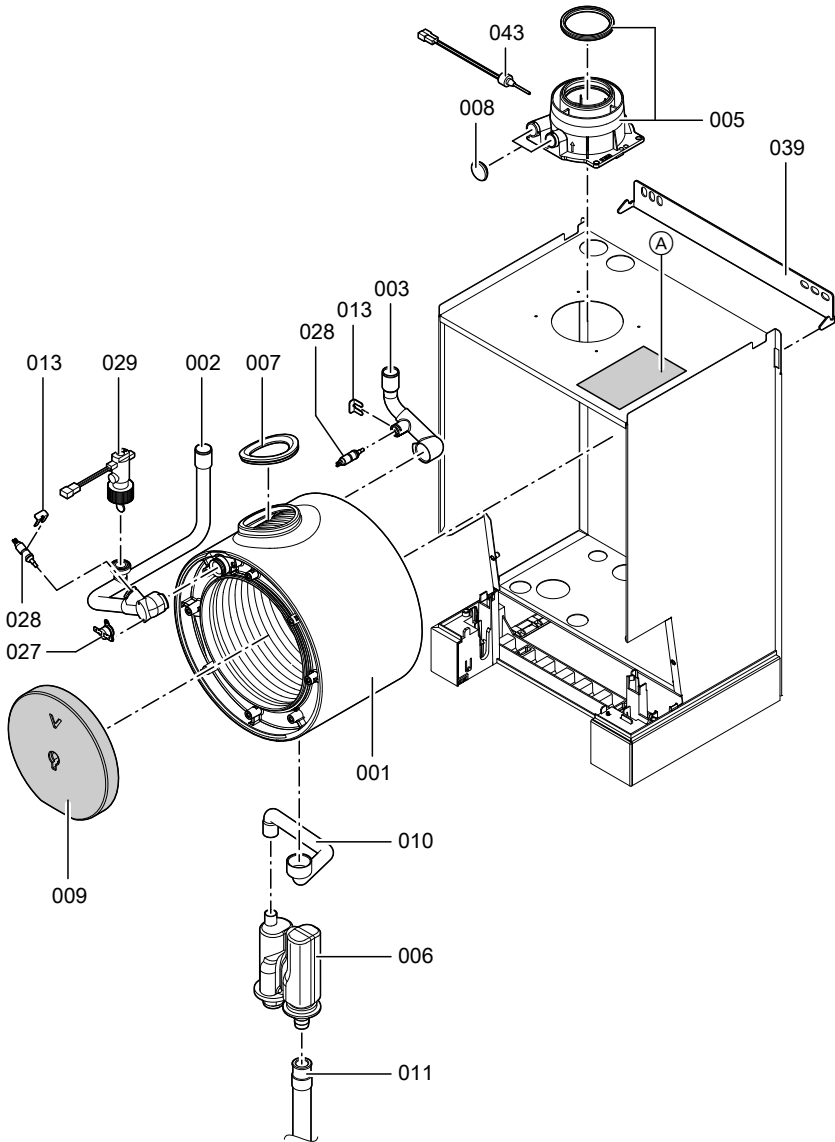

Specification

Rated voltage:	230 V~	Temperature limiter	
Rated frequency:	50 Hz	setting:	100 °C (fixed)
Rated current:	2.0 A~	Line fuse (mains):	max. 16 A
Safety class:	I		
Protection:	IP X4 to EN 60529		

Permissible ambient temperature

- During operation: 0 to +40 °C
- During storage
- and transport: -20 to +65 °C

Gas fired condensing boilers, class II_{2H3P}

Rated output range					
T_V/T_R 50/30 °C	kW	7.9 - 13	7.9 - 16	7.9 - 19	7.9 - 26
T_V/T_R 80/60 °C	kW	7.2 - 11.9	7.2 - 14.6	7.2 - 17.3	7.2 - 23.7
Rated thermal load range	kW	7.4 - 12.2	7.4 - 15.0	7.4 - 17.8	7.4 - 24.3
Connection values ^{*1}					
relative to the max. load with					
Natural gas H	m ³ /h	1.3	1.6	1.9	2.6
LPG P	kg/h	0.9	1.1	1.4	1.9
Power consumption (max.)	W	45	50	55	60
Weight without front panel (installation)	kg	24	24	24	24
Product ID	C€-0085 BT 0029				

Min. static pressure: 0,2 bar

Min. throughput: 200 l/h

^{*1} The connection values are only for documentation purposes (e.g. in the gas contract application) or to estimate the supplementary volumetric settings. Because of factory settings, the gas pressure must not be altered from these settings. Reference: 15 °C, 1013 mbar.

Declaration of conformity

Declaration of conformity for the Vitodens 100-W

We, Viessmann Werke GmbH & Co KG, D-35107 Allendorf, confirm as sole responsible body that the product **Vitodens 100-W** complies with the following standards:

DIN 4702-6	EN 55 014
EN 483	EN 60 335
EN 625	EN 61 000-3-2
EN 677	EN 61 000-3-3
EN 50 165	

In accordance with the following directives, this product is designated **CE-0085**:

90/396/EEC	2004/108/EC
92/ 42/EEC	2006/95/EC

This product complies with the requirements of the Efficiency Directive (92/42/EEC) for **condensing boilers**.

Allendorf, 4 February 2009

Viessmann Werke GmbH&Co KG



pp. Manfred Sommer

Keyword index

B

Boiler water temperature sensor.....	33
Burner gasket.....	21
Burner gauze assembly.....	21
Burner installation.....	24
Burner removal.....	20

C

Cleaning the combustion chamber... ..	22
Cleaning the heat exchanger.....	22
Commissioning.....	16
Condensate connection.....	10
Condensate drain.....	23
Connection diagram.....	40
Connections.....	9
Connections on the water side.....	9

D

Declaration of Conformity.....	46
--------------------------------	----

E

Electrical connections.....	12
-----------------------------	----

F

Fault code.....	27
Fault messages.....	27
Filling function.....	16
Filling the system.....	16
Flue gas temperature sensor.....	34
Flue pipe.....	11
Frost protection.....	39
Function sequence.....	26
Fuse.....	36

G

Gas connection.....	9
Gas type conversion	37
■ LPG.....	16
■ Natural gas.....	37

H

Heating curve.....	39
--------------------	----

I

Ignition.....	22
Ignition electrode.....	17, 22
Ionisation electrode.....	22

O

Opening the control unit casing.....	11
Outside temperature sensor	31

R

Reset.....	30
------------	----

S

Safety chain	35
Siphon.....	10, 23
Spare parts.....	42
Specification	45

T

Temperature limiter.....	35
Troubleshooting.....	31

V

Ventilation air pipe.....	11
---------------------------	----

W

Wall mounting.....	6
Weather-compensated mode.....	39

Viessmann Werke GmbH&Co KG
D-35107 Allendorf
Telephone: +49 6452 70-0
Fax: +49 6452 70-2780
www.viessmann.com

Viessmann Limited
Hortonwood 30, Telford
Shropshire, TF1 7YP, GB
Telephone: +44 1952 675000
Fax: +44 1952 675040
E-mail: info-uk@viessmann.com

5368 662 GB Subject to technical modifications.



Printed on environmentally friendly,
chlorine-free bleached paper