Wall hung, fan flue, room sealed, high efficiency gas boiler

Service manual

ActivA

Models:	G.C. Appl. No.
Activ A 25C	47-583-21
Activ A 30C	47-583-22
Activ A 35C	47-583-23
Activ A 18S	41-583-11
Activ A 25S	41-583-12
Activ A 30S	41-583-13

Leave this manual adjacent to the gas meter

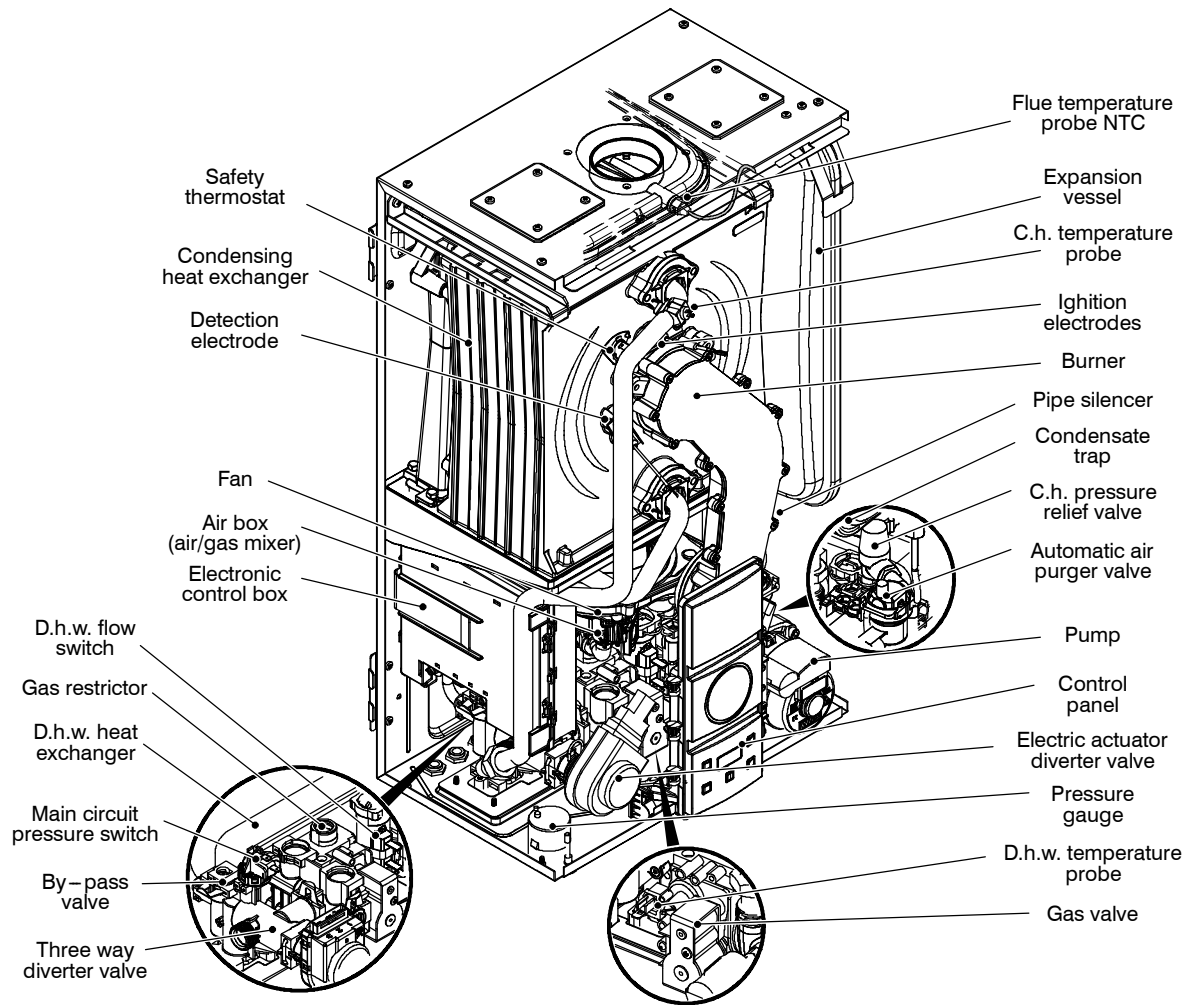

Table of contents

1	Overall information	1	11	Gas valve	27
1.1	Overall View	1	11.1	Function	27
1.2	Hydraulic diagram	1	11.2	Description of the parts	27
2	General access and emptying hydraulic circuits	2	11.3	Adjustment	27
2.1	Nomenclature	2	11.4	Checks	29
2.2	Body panels	2	11.5	Removal of the gas valve	29
2.3	Control panel	2	12	Primary circuit flow switch	30
2.4	Main electronic p.c.b. box	3	12.1	Function	30
2.5	Emptying the primary circuit	3	12.2	Checks	30
2.6	Emptying the d.h.w. circuit	4	12.3	Removal	30
3	Diagrams	5	13	Expansion vessel and pressure gauge	30
3.1	Wiring diagram Activ A 25C Activ A 30C. Activ A 35C.	5	13.1	Function	30
3.2	Wiring diagram Activ A 18S Activ A 25S Activ A 30S	6	13.2	Checks	30
3.3	Circuit voltages	7	13.3	Removal of the expansion vessel	31
4	Fault finding	8	13.4	Removal of the pressure gauge	31
4.1	Display diagnostic	10	14	D.h.w. flow switch, filter and flow limiter	33
5	Condensing heat exchanger	11	14.1	Function	33
5.1	Function	11	14.2	Description and location of parts	33
5.2	Removal	11	14.3	Checks	33
5.3	Cleaning	12	14.4	Removal of the sensor	33
6	D.h.w. heat exchanger	13	14.5	Removal of the flow switch group and d.h.w. circuit filter	33
6.1	Function	13	14.6	Flow limiter	34
6.2	Removal	13	15	Temperature probe	35
7	Pump	14	15.1	Function	35
7.1	Function	14	15.2	Checks	35
7.2	Checks	14	15.3	Removal of the c.h. Temperature probe ..	35
7.3	Removal pump	14	15.4	Removal of the d.h.w. Temperature probe	35
7.4	Removal electrical capacitor	15	16	By-pass valve	37
8	Three way diverter valve	16	16.1	Function	37
8.1	Function	16	16.2	Removal	37
8.2	Checks	16	17	Fan and Air box	38
8.3	Removal of the electric actuator	16	17.1	Function	38
8.4	Removal of the three way diverter valve ..	17	17.2	Removal of the Fan and the Air box	38
8.5	Removal of the diverter group	17	18	Ignition and detection electrodes and burner	39
9	Main electronic control/ignition p.c.b. ..	18	18.1	Function	39
9.1	Function	18	18.2	Removal of the Ignition and detection electrodes	39
9.2	Selection and adjustment devices	18	18.3	Removal of the burner	39
9.3	Checking the temperature	19	18.4	Checks	39
9.4	Setting the boiler control function modes	20	19	Safety thermostat	41
9.5	Checks	22	19.1	Function	41
9.6	Removal of the electronic control p.c.b. ..	22	19.2	Checks	41
9.7	Thermal control in the "☀" mode	23	19.3	Removal	41
9.8	Thermal control in the "☀" mode	24	20	Flue temperature probe NTC and Safety thermal fuse	42
10	Control panel electronic p.c.b.	25	20.1	Function	42
10.1	Function	25	20.2	Removal	42
10.2	Info modality	25	20.3	Checks	42
10.3	Function modes setting modality	25	21	Condensate trap	43
10.4	Removal of the control panel electr. p.c.b	25	21.1	Function	43
			21.2	Check the cleanness of the trap	43
			21.3	Removal	43
			22	Short spare parts list	44

1 Overall information

1.1 Overall View



1.2 Hydraulic diagram

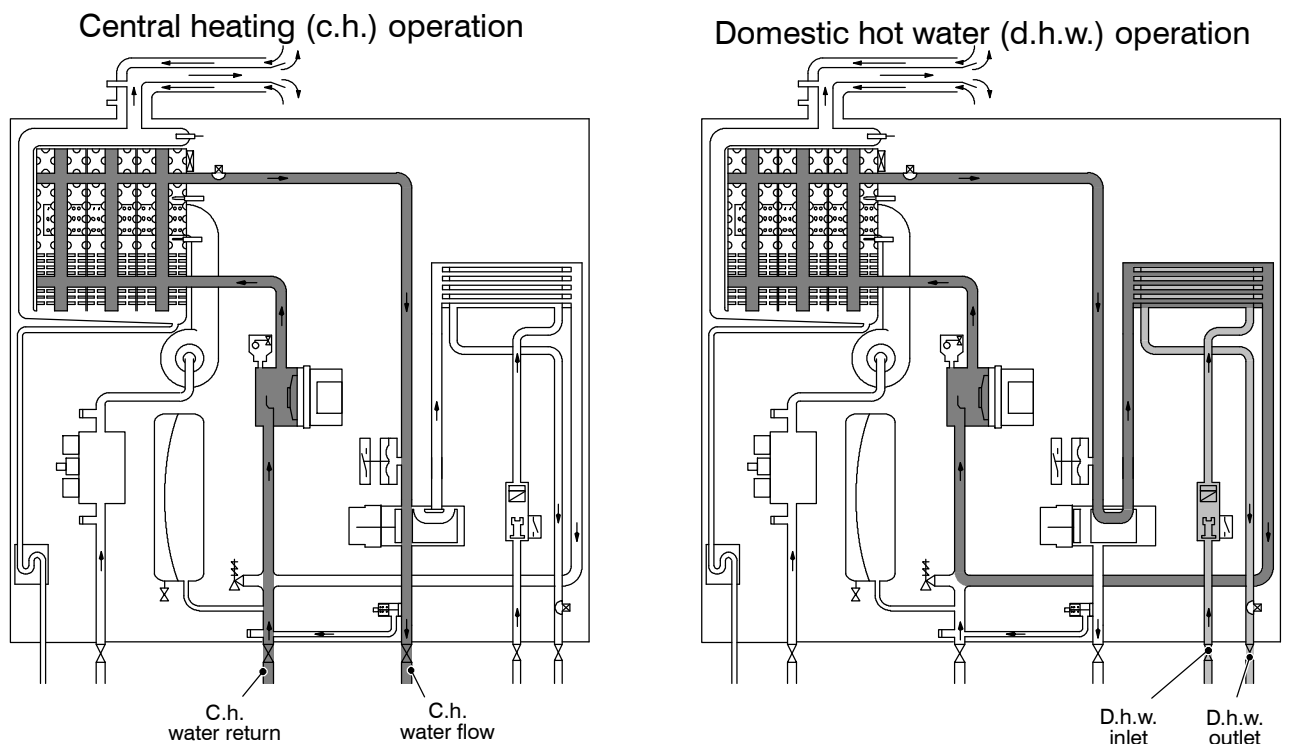

2 General access and emptying hydraulic circuits

2.1 Nomenclature

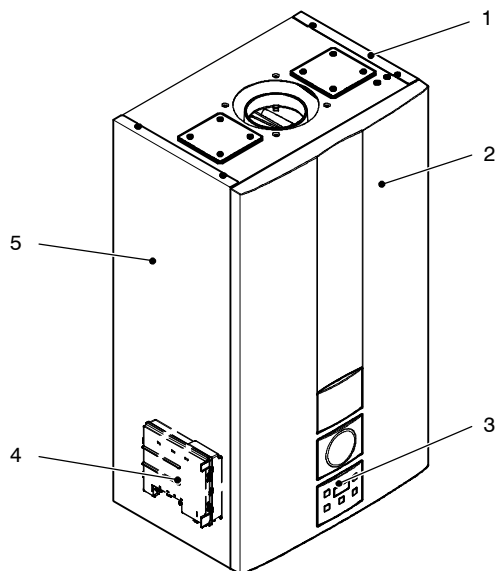

Fig. 2.1

- 1 Right side panel
- 2 Front panel
- 3 Control panel
- 4 Main electronic p.c.b. box
- 5 Left side panel

2.2 Body panels

Warning: isolate the boiler from the mains electricity supply before removing any covering or component.

For the most part of the check and maintenance operations it is necessary to remove one or more panels of the case.

The side panels can be removed only after the removal of the front panel.

To remove the front panel loosen screws A (Fig. 2.2).

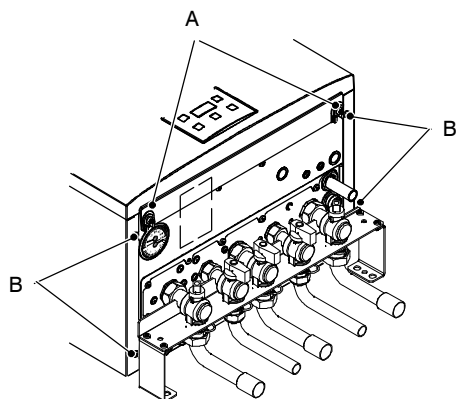

Fig. 2.2 – bottom view of the boiler

Pull the lower part of the front panel and lift it upwards (Fig. 2.3).

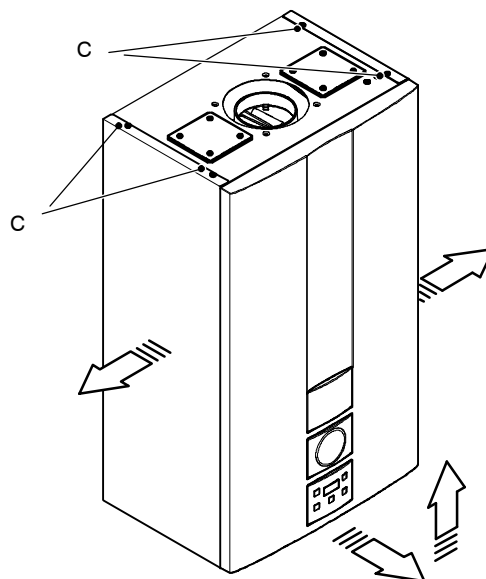

Fig. 2.3

To remove the side panels loosen the screws B (Fig. 2.2) and C (Fig. 2.3).

Pull the side panels towards the outside.

2.3 Control panel

Warning: isolate the boiler from the mains electricity supply before removing any covering or component.

To gain access to the parts located inside the control panel proceed as follows:

- 1 Remove the front panel of the case.
- 2 To open the control panel by levering with a screwdriver in as shown in Fig. 2.4

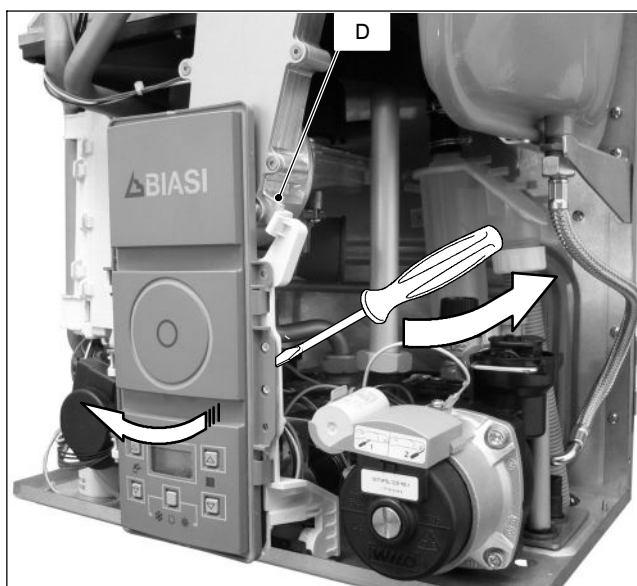

Fig. 2.4

- 3 To access to the parts located inside the control panel to free the hook D (Fig. 2.4) and turn it as shown in Fig. 2.5.

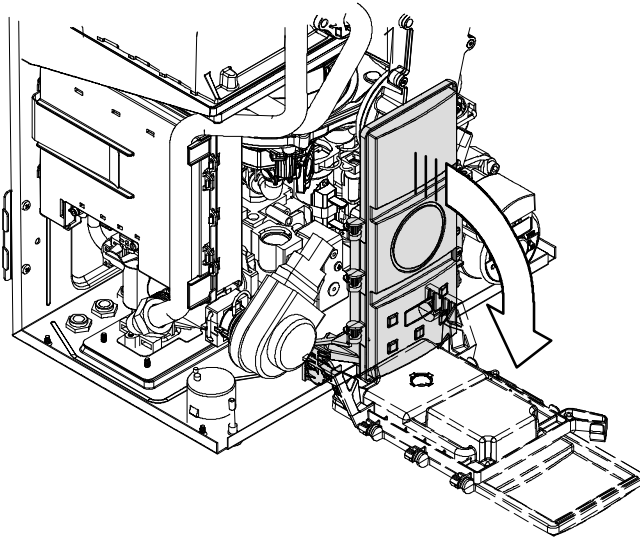

Fig. 2.5

2.4 Main electronic p.c.b. box

Warning: isolate the boiler from the mains electricity supply before removing any covering or component.

To gain access to the parts located into main electronic p.c.b. box proceed as follows:

- 1 Remove the front panel of the case.

Terminal block lid removal

- 2 To remove the terminal block lid *E* (Fig. 2.6), free the front hooks.

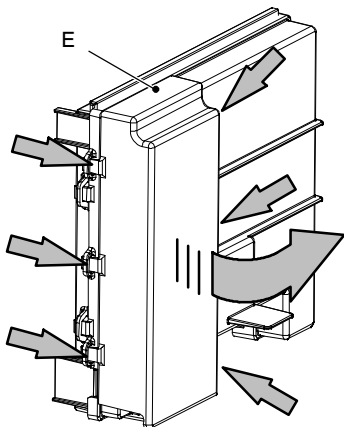

Fig. 2.6

- 3 Slightly rotate the lid as indicated by the curved arrow and free the rear hooks.
- 4 Remove the lid.

Main electronic p.c.b. lid removal

To get access to the main electronic p.c.b.:

- 5 Pull the box that contains the electronic p.c.b. and rotate it (Fig. 2.7).

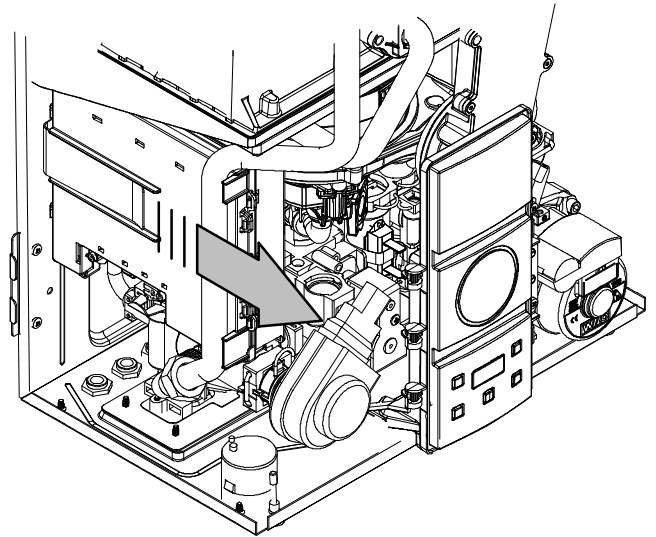

Fig. 2.7

- 6 Remove the terminal block lid *E* (Fig. 2.6).
- 7 Free the hooks placed on the three sides indicated and rotate the lid towards left (Fig. 2.8).

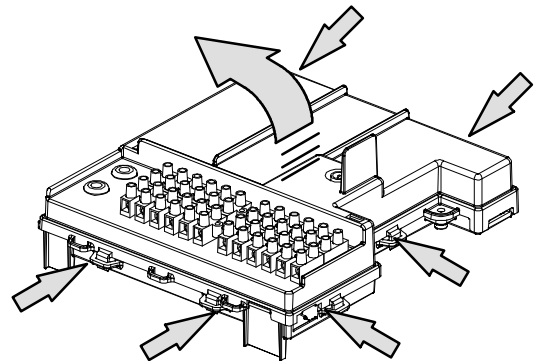

Fig. 2.8

2.5 Emptying the primary circuit

- 1 Close the c.h. circuit flow and return cocks *F*. (Fig. 2.9).

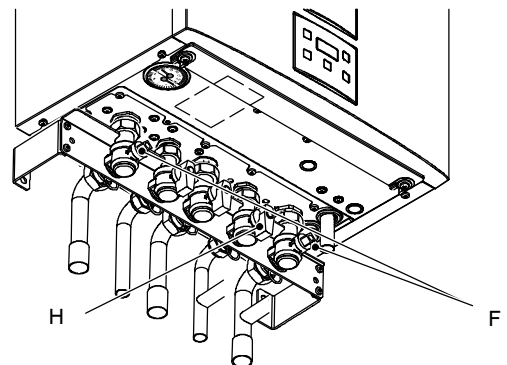

Fig. 2.9 – bottom view of the boiler

- 2 Remove the front and right panels of the boiler.
- 3 Open the drain tap *G* (Fig. 2.10 combi or Fig. 2.11 only c.h.) until the boiler is completely emptied.
- 4 Close drain tap once the emptying has been completed.

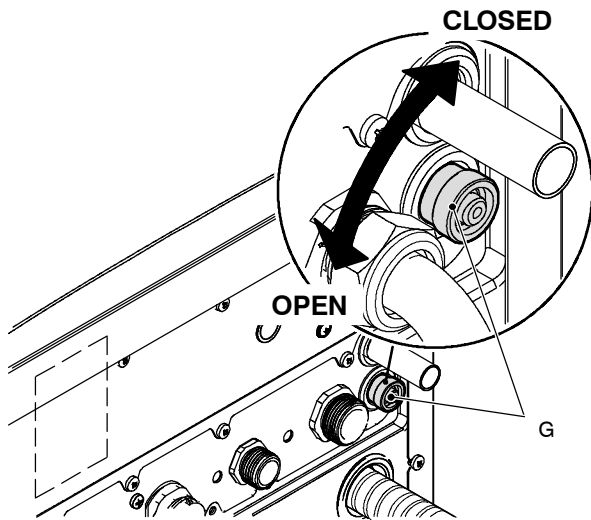

Fig. 2.10

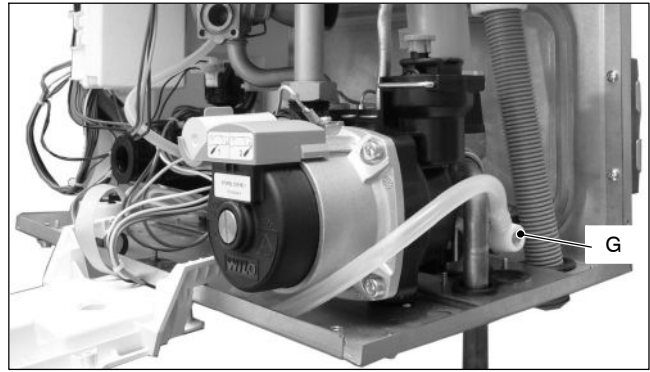

Fig. 2.11

2.6 Emptying the d.h.w. circuit

- 5 Close the d.c.w. inlet cock *H* (Fig. 2.9).
- 6 Open one or more hot water taps until the boiler has been completely emptied.

3 Diagrams

3.1 Wiring diagram Activ A 25C Activ A 30C. Activ A 35C.

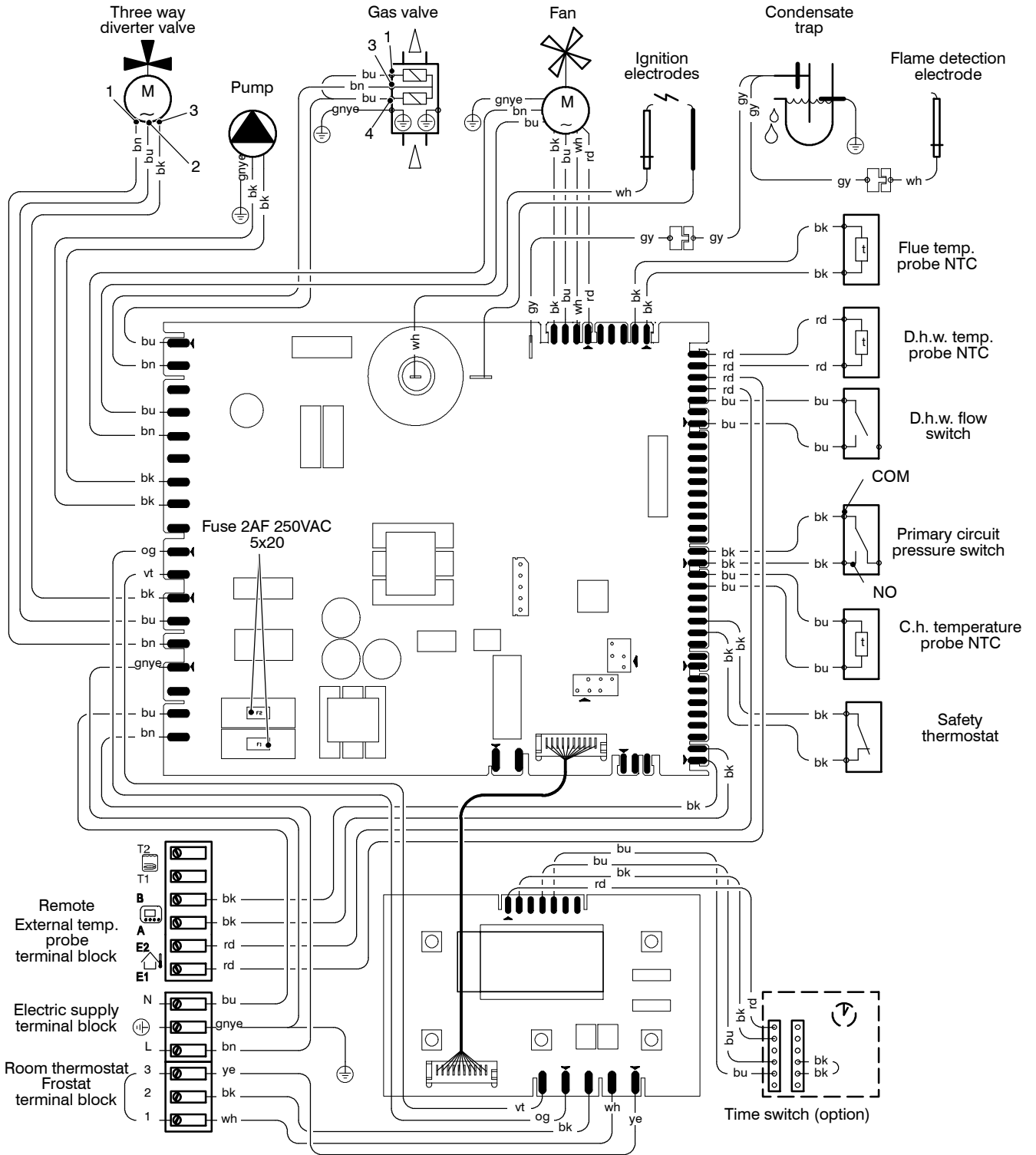

- | | |
|------------|---------------------|
| bn = brown | gn = green |
| bu = blue | ye = yellow |
| bk = black | vt = violet |
| wh = white | og = orange |
| rd = red | gnye = green/yellow |
| gy = grey | rdwh = red/white |

3.2 Wiring diagram
 Activ A 18S Activ A 25S Activ A 30S

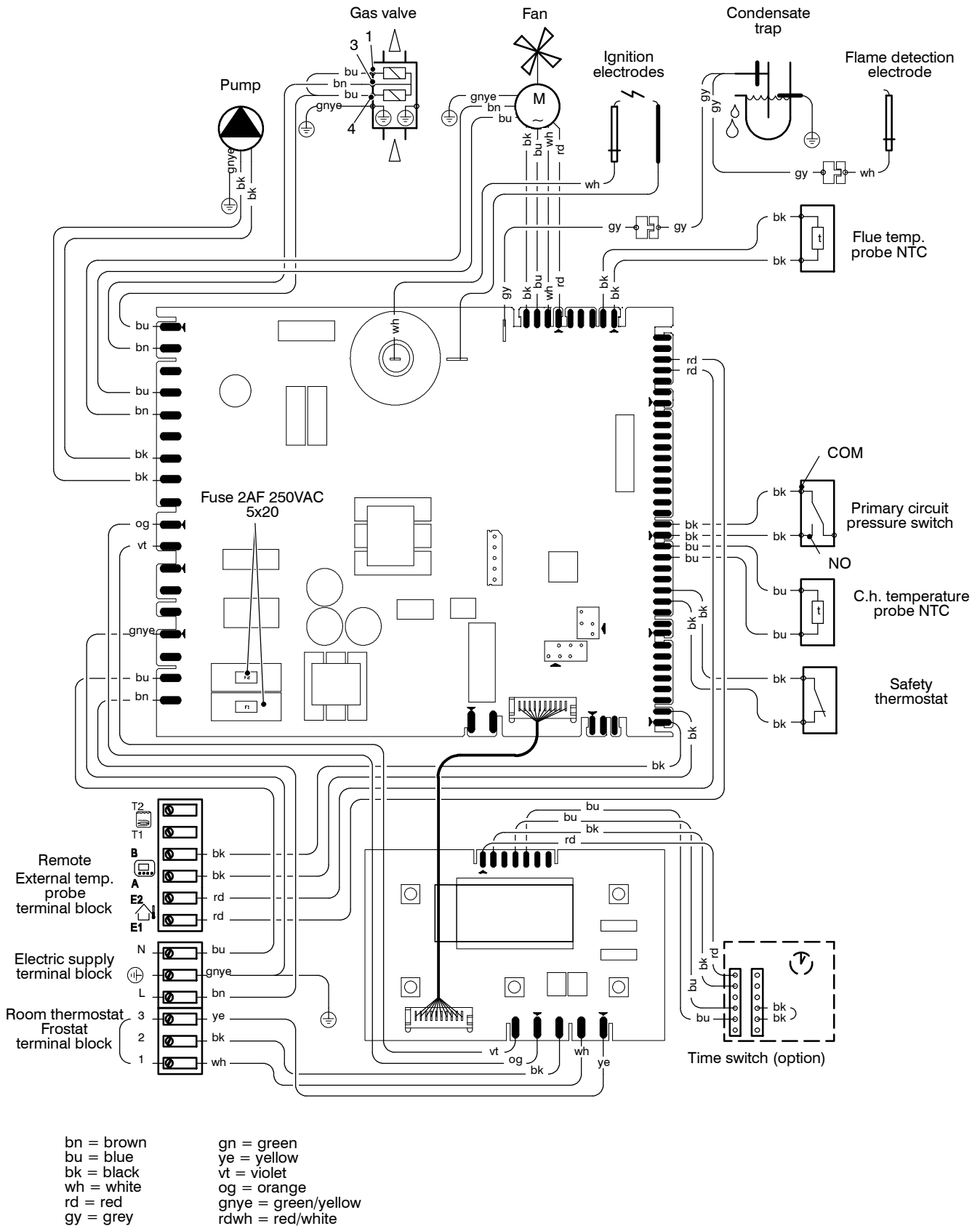

3.3 Circuit voltages

Electrical voltages with burner on

- during c.h. or d.h.w. operation
- only during **c.h.** operation
- only during **d.h.w.** operation

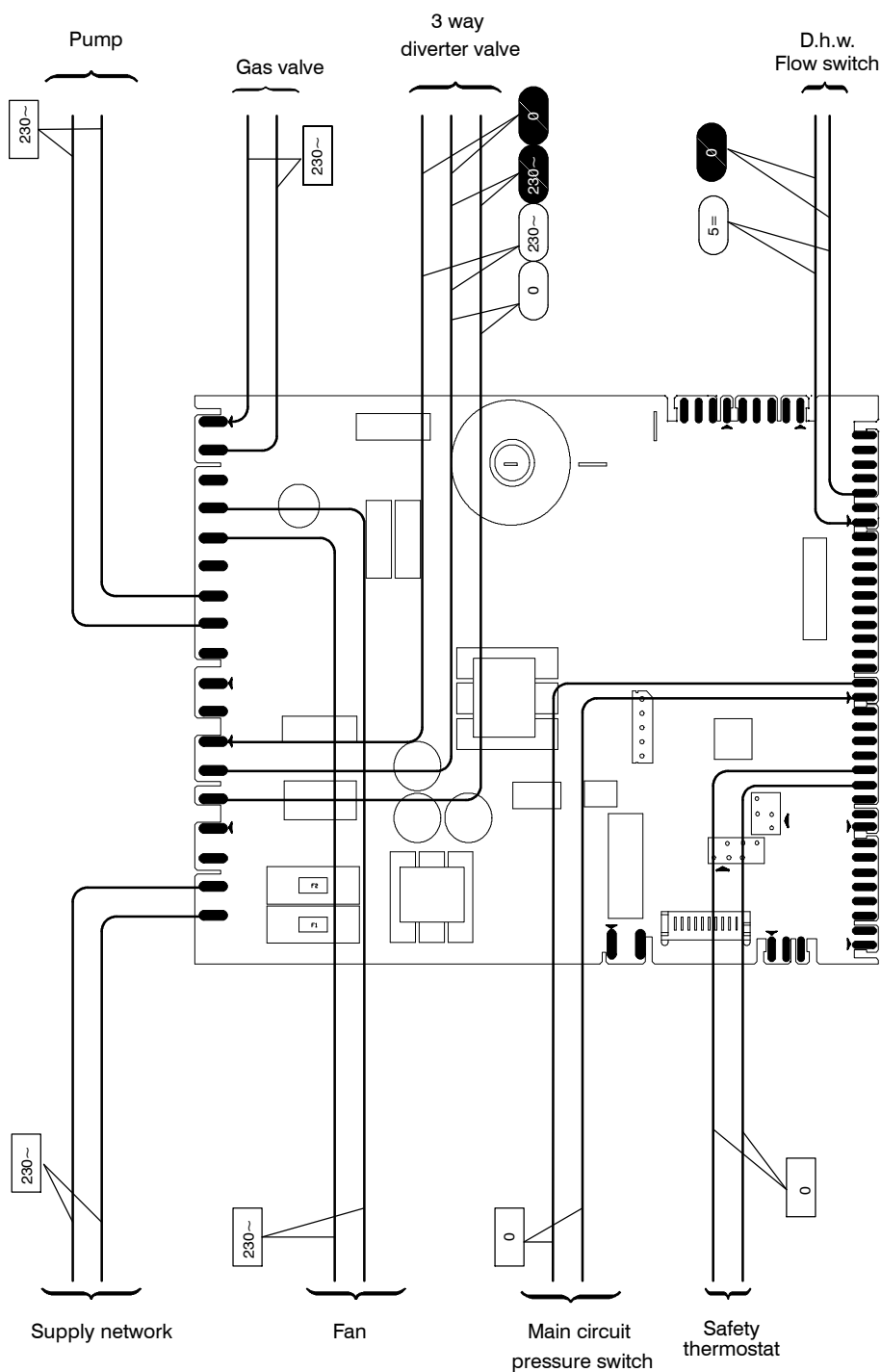







4.1 Display diagnostic

An help for the fault finding may be given by the display indications.

The display on the control panel gives many information.

Only the indications useful for the fault finding are here described.

The following table gives the relationship between the indications of error of the display and their meaning.

Er 01 + RESET	Lack of burner ignition
Er 02 + RESET	Safety thermostat lockout
Er 03 + RESET	Other faults
Er 04 + 	Faulty primary circuit (no water or absence of flow)
Er 05 + 	Faulty fan control system
Er 06 + 	Faulty c.h. temperature probe NTC
Er 07 + 	Faulty d.h.w. temperature probe NTC
Er 08 + 	Faulty external temperature probe NTC (if fitted)
Er 09 + 	Faulty flue temperature probe NTC
Er 10 + RESET	Lockout – flue temperature probe NTC (Flue temperature > 120 °C)
Er 11 + RESET	Parasite flame
Er 14 + 	Faulty primary circuit (no water or absence of flow) (temperature increase > 2K/s) (the boiler can't restart for 10 minutes)
Er 14 + RESET	Faulty pump (absence of water flow in the main circuit) or primary temperature above 105 °C
Li 01	Primary circuit temperature limit during d.h.w. operation

5 Condensing heat exchanger

5.1 Function

The Condensing heat exchanger *A* in Fig. 5.1 has the function of transferring heat produced from combustion of the gas and from the flue exhausted gas to the water circulating in it.

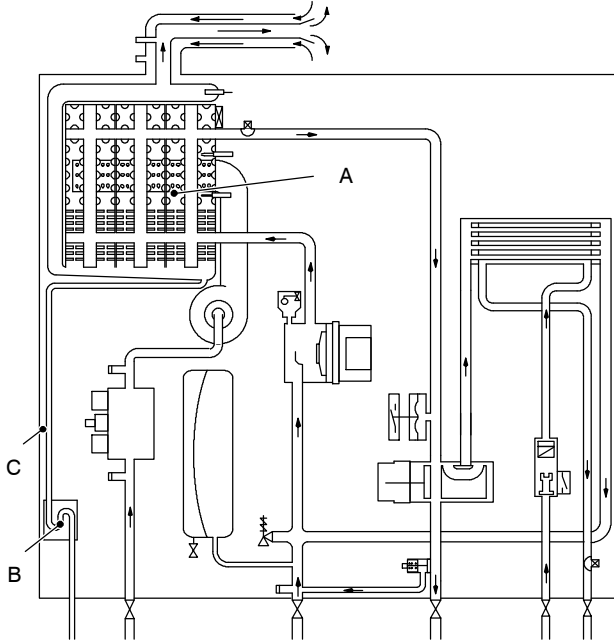

Fig. 5.1

By reducing the combustion products temperature, the latent heat of the vapour is transferred to the water circuit, allowing an extra gain of useful heat.

The condensed vapour is then drained through the condensate trap *B* and the draining pipe *C*.

5.2 Removal

Warning: isolate the boiler from the mains electricity supply before removing any covering or component.

- 1 Turn off the gas supply.
- 2 Remove all the case panels (see section 2).
- 3 Disconnect the flue system from the boiler.
- 4 Disconnect the air manifold *D* (Fig. 5.2) by pulling it.
- 5 Disconnect the rubber pipe *E*.
- 6 Unscrew the gas connector *F*.
- 7 Remove the fixing fork *G* and remove the gas pipe *H*.
- 8 Unscrew the screws and remove the detection electrode connector *I* (Fig. 5.2)
- 9 Unscrew the screws and remove the ignition electrodes connector *J*.
- 10 Unscrew the screw and remove the overheat thermostat *K*.
- 11 Disconnect the connector *L* by pressing the plastic hook placed on the side of the connector.
- 12 Disconnect the connector *M*

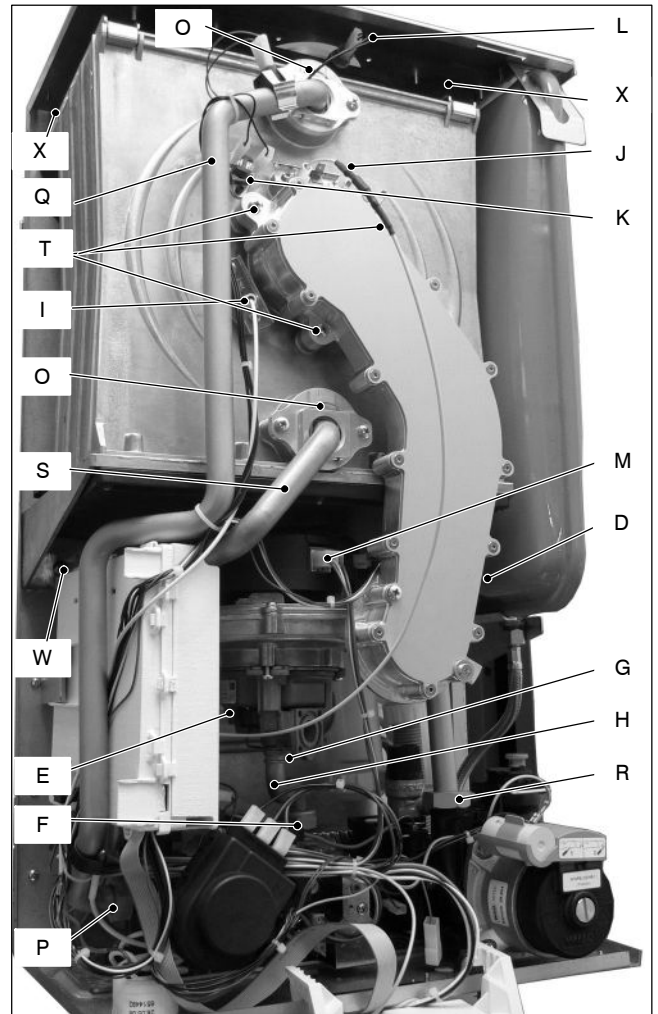

Fig. 5.2

- 13 Disconnect the fan connector *N* by pressing the plastic hook placed on the side of the connector (Fig. 5.3).

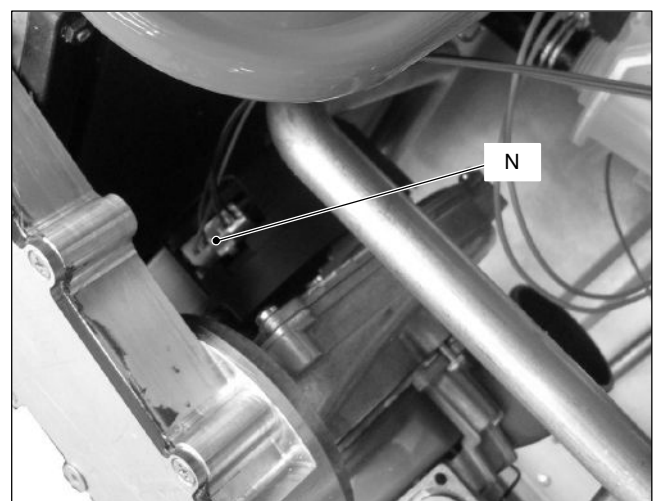

Fig. 5.3

- 14 Empty the primary circuit of the boiler.
- 15 Remove the expansion vessel following the instructions in section 13.3.
- 16 Remove the forks *O* (Fig. 5.2).
- 17 Loosen the connection *P* and remove the pipe *Q* from the Condensing heat exchanger.

Condensing heat exchanger

- 18 Loosen the connection *R* and remove the pipe *S* from the Condensing heat exchanger.
- 19 Unscrew the screws *T* .
- 20 Remove the fan–burner group.

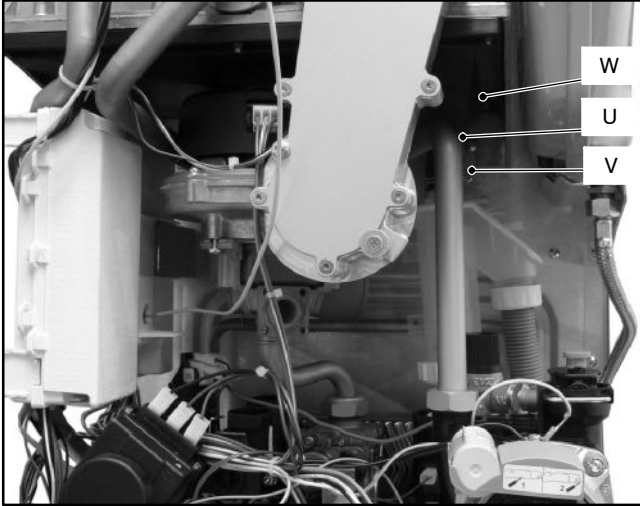

Fig. 5.4

- 21 Using pliers, remove the spring *U* moving it downwards and disconnect the rubber pipe *V* (Fig. 5.4).
- 22 Loosen the screws *W* (Fig. 5.4 – Fig. 5.2)
- 23 Unscrew the screws *X* (Fig. 5.2).
- 24 Remove the Condensing heat exchanger slightly move it upwards, turn it frontwards freeing it from the below screws *W* (Fig. 5.4 – Fig. 5.2) and then extract it forwards.
- 25 Reassemble the Condensing heat exchanger carrying out the removal operations in reverse order.

Ensure to tight the screws *T* – Fig. 5.2 firmly

5.3 Cleaning

If there are deposits of dirt between the fins of the Condensing heat exchanger, clean with a bristle paintbrush and remove the dust with a Hoover.



Warning: After cleaning or replacement as detailed above, if it deemed necessary to undertake a combustion analysis, refer to the appropriate chapter *Maintenance* of the installation instructions manual.

6 D.h.w. heat exchanger

6.1 Function

The d.h.w. heat exchanger *A* in Fig. 6.1 and Fig. 6.3 allows the instantaneous transfer of heat from the primary hydraulic circuit to the water destined for d.h.w. use.

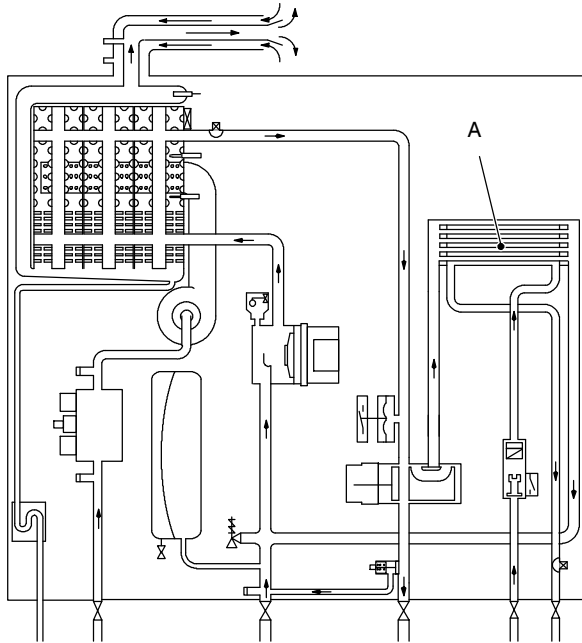
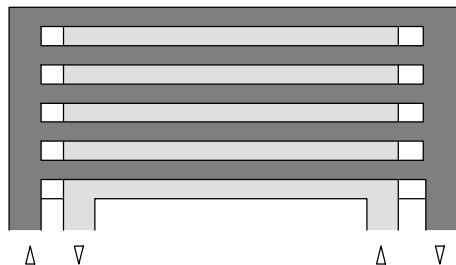

Fig. 6.1

The schematic structure is shown in Fig. 6.2.



- Primary hydraulic circuit
- Domestic hot water circuit

Fig. 6.2

6.2 Removal

Warning: isolate the boiler from the mains electricity supply before removing any covering or component.

- 1 Remove the panels of the case.
- 2 Empty the primary circuit and the d.h.w. circuit of the boiler.
- 3 Remove the control panel following the instructions from 3 in section 2.3.
- 4 Remove main electronic p.c.b. box following the instructions from 5 in section 2.4.
- 5 Remove the pump following the instructions in section 7.3.
- 6 Completely unscrew the Allen key screws *B* (Fig. 6.3) which hold the exchanger to the plastic groups.

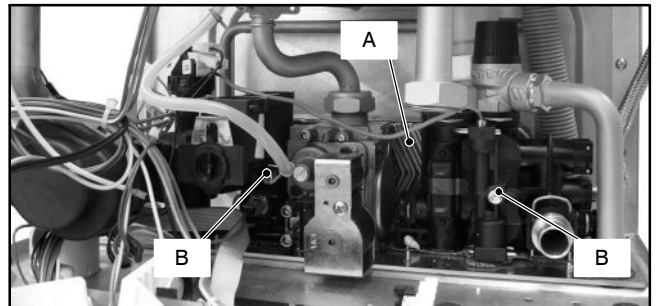

Fig. 6.3

- 7 Move the exchanger towards the rear of the boiler and extract it leftwards.

Reassemble the d.h.w. heat exchanger carrying out the removal operations in the reverse order.

Warning: to lubricate the O-ring gaskets exclusively use a silicone base grease compatible to be in contact with foods and approved by the local water Authorities.

Attention. When reassembling the exchanger be sure to put the off centre location/securing pin indicated in Fig. 6.4 towards the left side of the boiler.

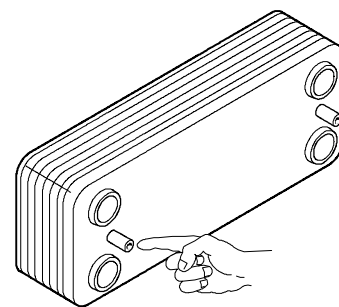

Fig. 6.4

7 Pump

7.1 Function

The pump A in Fig. 7.1 and Fig. 7.3 has the function of making the water in the main circuit circulate through the main condensing heat exchanger and therefore through the c.h. system (during the c.h. function) or through the secondary heat exchanger (during the d.h.w. function).

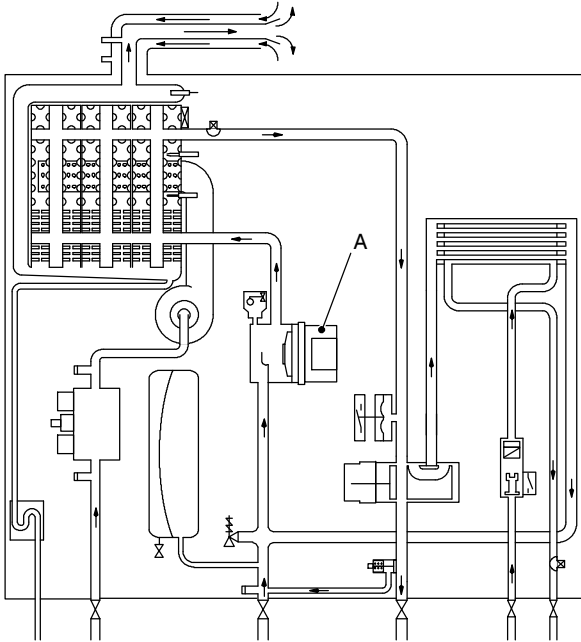

Fig. 7.1

7.2 Checks

Warning: isolate the boiler from the mains electricity supply before removing any covering or component.

Check that the pump is not seized and that the movement of the rotor is not subject to mechanical impediments.

With the boiler off, remove the front panel. Remove the air release plug of the pump and turn the rotor with a screwdriver.

Check the electrical continuity.

With the boiler off, remove the front panel and disconnect the connector B (Fig. 7.3 – Fig. 7.4).

Measure the electrical resistance between the pump supply connections.

Electrical resistance of the windings (at ambient temperature) must be about 213 Ω (coil 1) and 480 Ω (coil 2) (Fig. 7.2).

Check the absence of starting defects.

With the boiler off remove the front case panel.

Remove the air release plug from the pump. Start the boiler and with a screwdriver, turn the rotor in the direction of the arrow. If there is a defect in starting, the rotor will begin to turn normally only starting it manually.

Check that the impeller is integral with the rotor.

With the boiler off remove the front and right hand side case panels, lower the control panel and empty the primary circuit.

Remove the pump head by undoing the screws which hold it to the pump body and check that the impeller is firmly joined to the rotor.

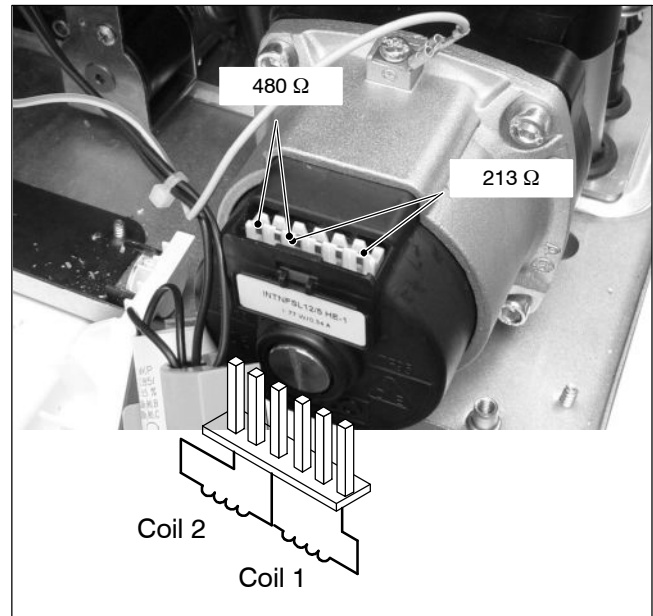

Fig. 7.2

7.3 Removal pump

Warning: isolate the boiler from the mains electricity supply before removing any covering or component.

- 1 Remove the front and right hand side case panels.
- 2 Empty the primary circuit of the boiler.
- 3 Disconnect the connector B (Fig. 7.3 – Fig. 7.4) following the indications given on the connector box.
- 4 Disconnect the earth connector C

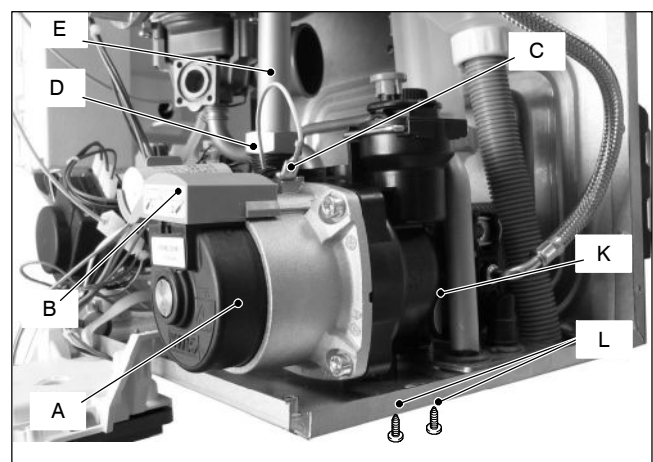

Fig. 7.3

- 5 Loosen the connection D, and pull up and turn to the left the pipe E.

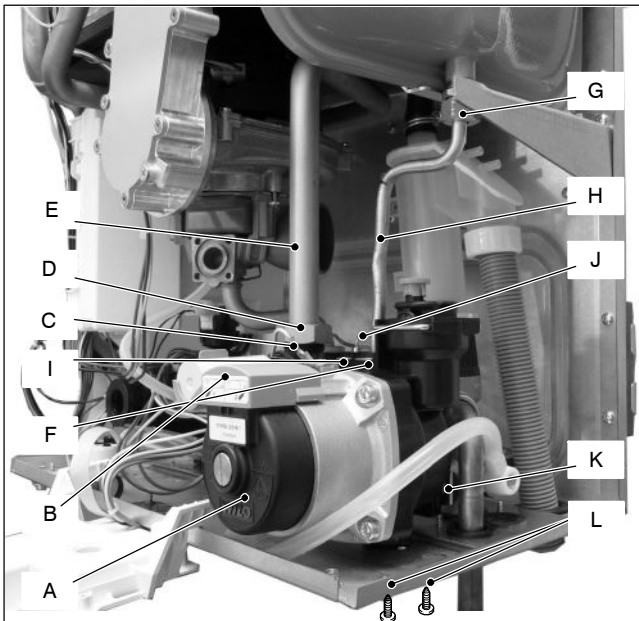

Fig. 7.4

- 6 C.H. only model remove the fork *F*, loosen the connection *G* and remove the pipe *H* (Fig. 7.4).
- 7 C.H. only model remove the fork *I* and remove the pressure gauge pipe *J* (Fig. 7.4).
- 8 Remove the locking plate *K* (Fig. 7.3 – Fig. 7.4).
- 9 Unscrew the two screws *L* that hold the pump on the frame and remove the pump.

Reassemble the pump carrying out the removal operations in the reverse order. When reassembling the pump, check the correct location of the O–ring gasket in the inlet port of the pump that seals the connection between the pump and the plastic group.

7.4 Removal electrical capacitor

Warning: isolate the boiler from the mains electricity supply before removing any covering or component.

- 1 Remove the front and right hand side case panels.
- 2 Disconnect the connector *B* (Fig. 7.3) following the indications given on the connector box.

- 3 Remove the connector *M* of the cover box by levering with a screwdriver in as shown in (Fig. 7.5)

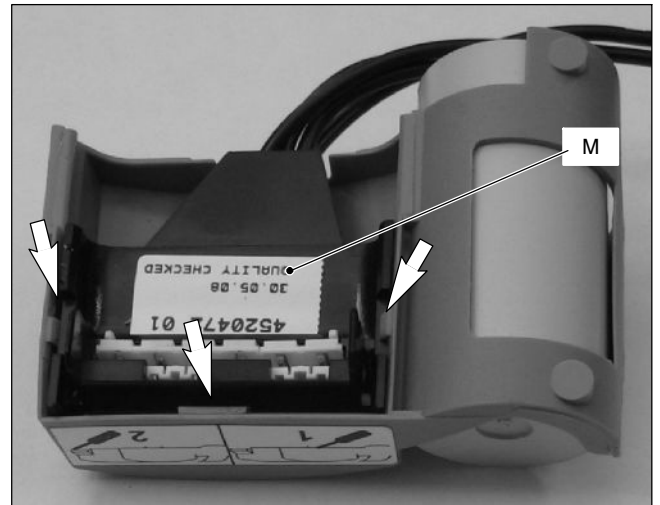

Fig. 7.5

- 4 Remove the capacitor connection block *N* freeing it from the hook *O* and pulling it as indicated by the arrow (Fig. 7.6).

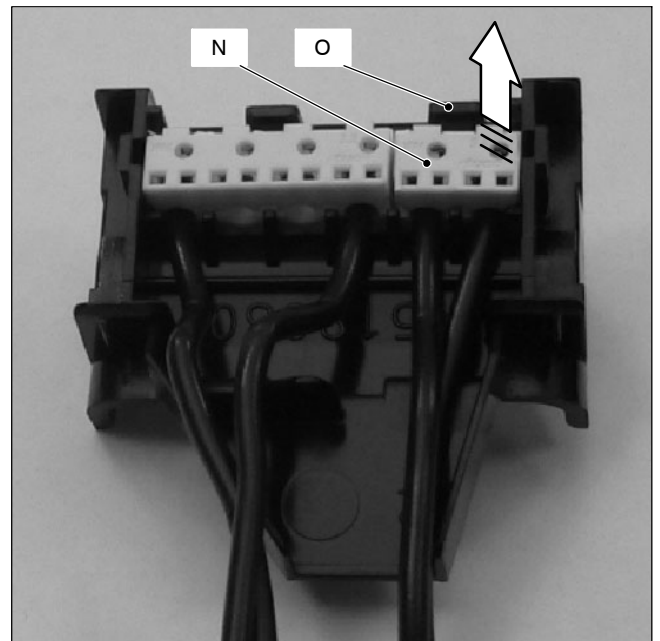

Fig. 7.6

8 Three way diverter valve

8.1 Function

The diverter valve A (Fig. 8.1) has the function of modifying the hydraulic circuit of the boiler by means of an electric command given by the electronic control p.c.b. in order to send the water that exits the primary heat exchanger towards the c.h. system or towards the d.h.w. heat exchanger.

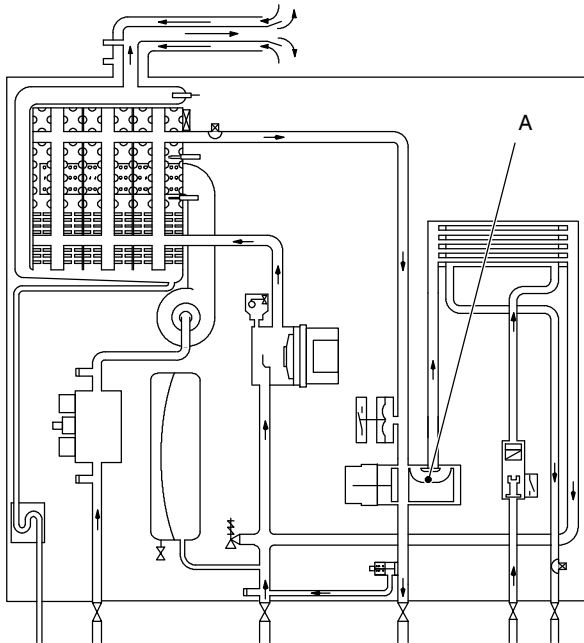

Fig. 8.1

8.2 Checks

✍ Check the electrical continuity

Fig. 8.2 indicates the relationship between the electric command coming from the electronic control p.c.b. and the position of the actuator B (brass spindle) when the boiler operates in **d.h.w. mode**.

Fig. 8.3 indicates the relationship between the electric command coming from the electronic control p.c.b. and the position of the actuator B (brass spindle) when the boiler operates in **c.h. mode**.

In both figures the relationship between the position of the actuator and the resistance of the motor windings (the motor must be disconnected from the wiring) is also given.

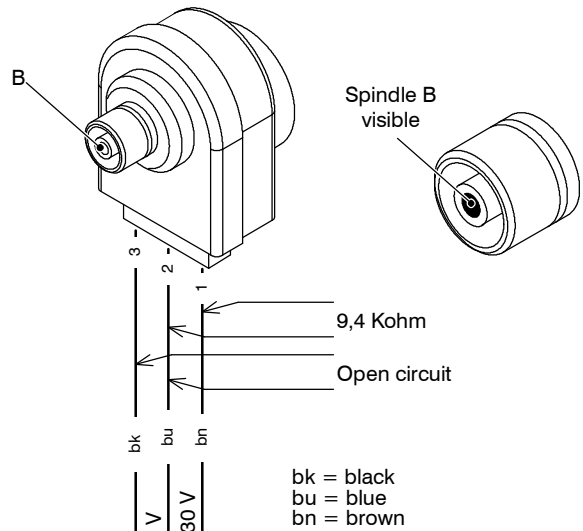

Fig. 8.2 – D.h.w. mode

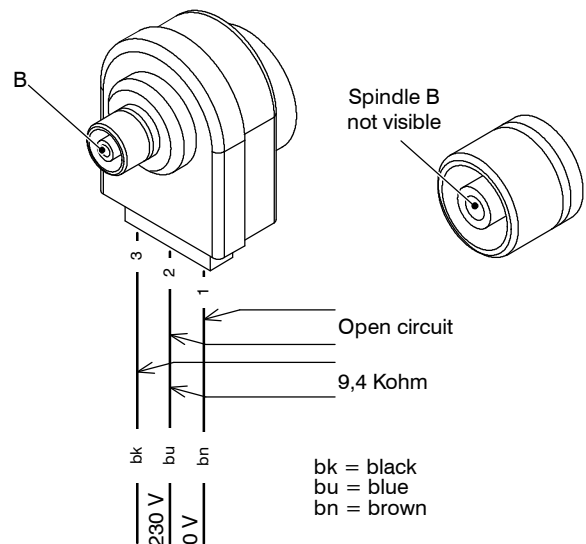

Fig. 8.3 – C.h. mode

8.3 Removal of the electric actuator

⚡ **Warning: isolate the boiler from the mains electricity supply before removing any covering or component.**

- 1 Remove the front case panel.
- 2 Disconnect the connectors C (Fig. 8.4).
- 3 Remove the fixing spring D and remove the actuator B.

Reassemble the actuator carrying out the removal operations in the reverse order.

When reassembling the actuator, refer to Fig. 8.2 or to the wiring diagram in section 8.2 for the correct wiring connection.

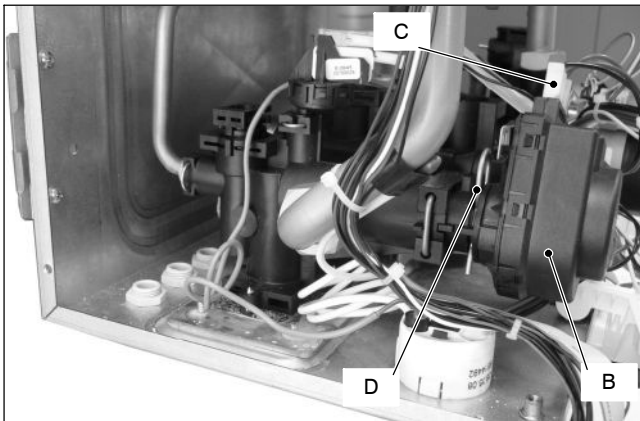

Fig. 8.4

8.4 Removal of the tree way diverter valve

- 1 Remove the front and both side case panels.
- 2 Empty the primary circuit and the d.h.w circuit of the boiler.
- 3 Remove the electric actuator (see section 8.3).
- 4 Remove the fixing spring *E* (Fig. 8.5)
- 5 Remove the tree way diverter valve *F* by levering with a screwdriver in as shown in Fig. 8.5.

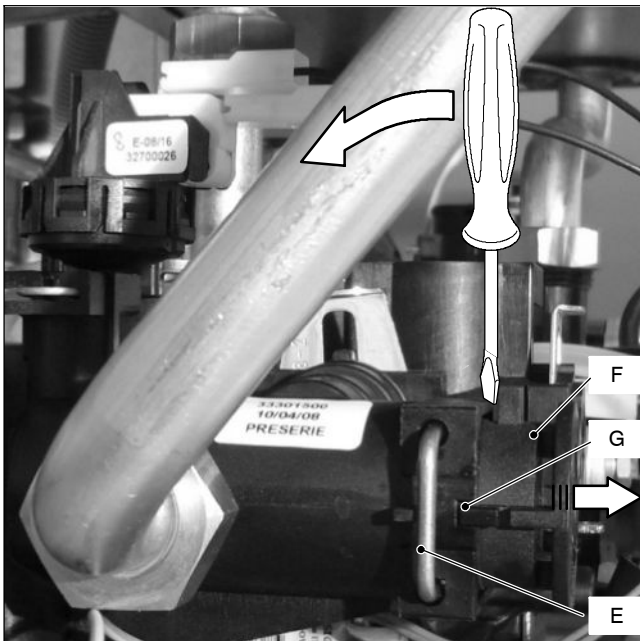

Fig. 8.5

Reassemble the tree way diverter valve carrying out the removal operations in the reverse order.

Warning: to lubricate the O-ring gaskets exclusively use a silicone base grease compatible to be in contact with foods and approved by the local water Authorities.

Attention. When reassembling the tree way diverter valve be sure that the tree way diverter is correctly oriented by matching the reference *G* with the notch of the water group Fig. 8.5

8.5 Removal of the diverter group

- 1 Remove the front and both side case panels.
- 2 Empty the primary circuit and the d.h.w circuit of the boiler.
- 3 Remove the electric actuator (see section 8.3).
- 4 Remove the fixing spring *H* (Fig. 8.6) and remove the primary circuit pressure switch *I*.

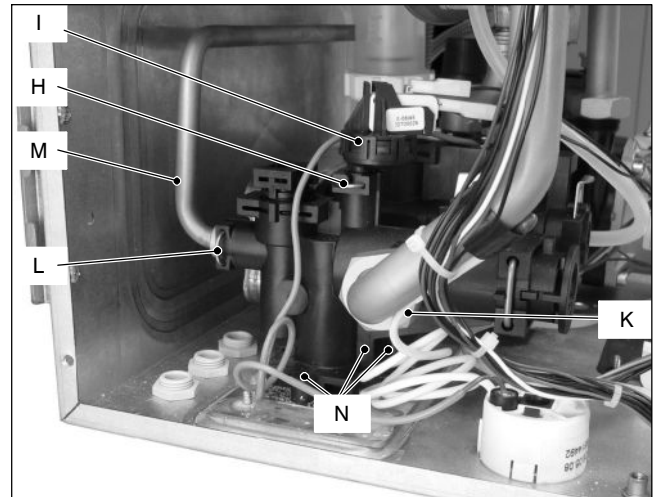

Fig. 8.6

- 5 Disconnect d.h.w. temperature probe, respectively *J* (Fig. 8.7).

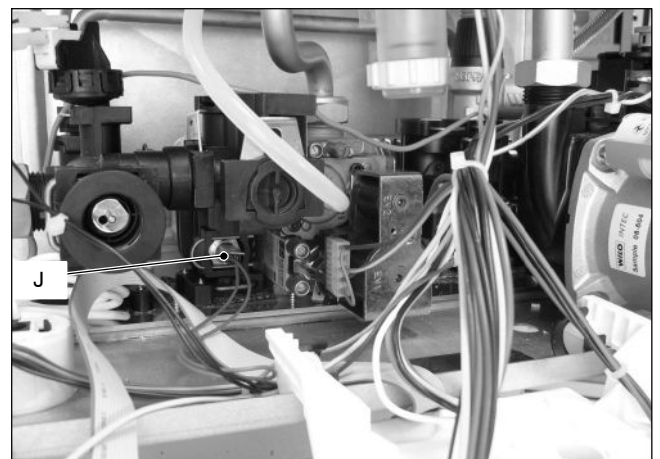

Fig. 8.7

- 6 Unscrew the connector *K* (Fig. 8.6), the c.h. flow connector and the d.h.w. outlet connector.
- 7 Remove the d.h.w. heat exchanger (see section 6.2).
- 8 Remove the fork *L* and move away the pipe *M* (Fig. 8.6).
- 9 Unscrew the screws *N* and remove the diverter group (Fig. 8.6).
- 10 Reassemble the diverter group carrying out the removal operations in the reverse order.

Warning: to lubricate the O-ring gaskets exclusively use a silicone base grease compatible to be in contact with foods and approved by the local water Authorities.

9 Main electronic control/ignition p.c.b.

9.1 Function

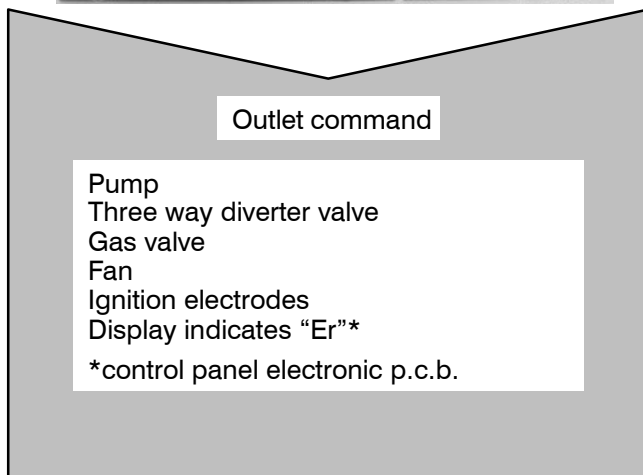
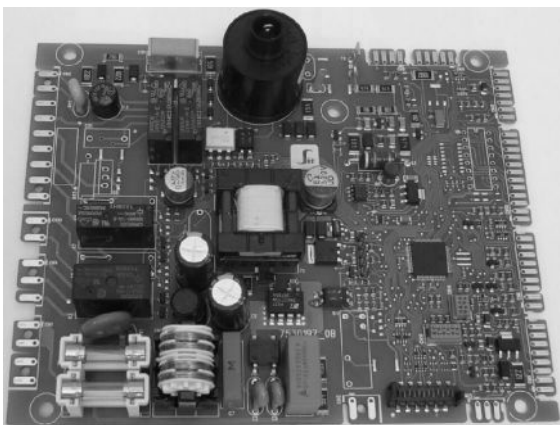
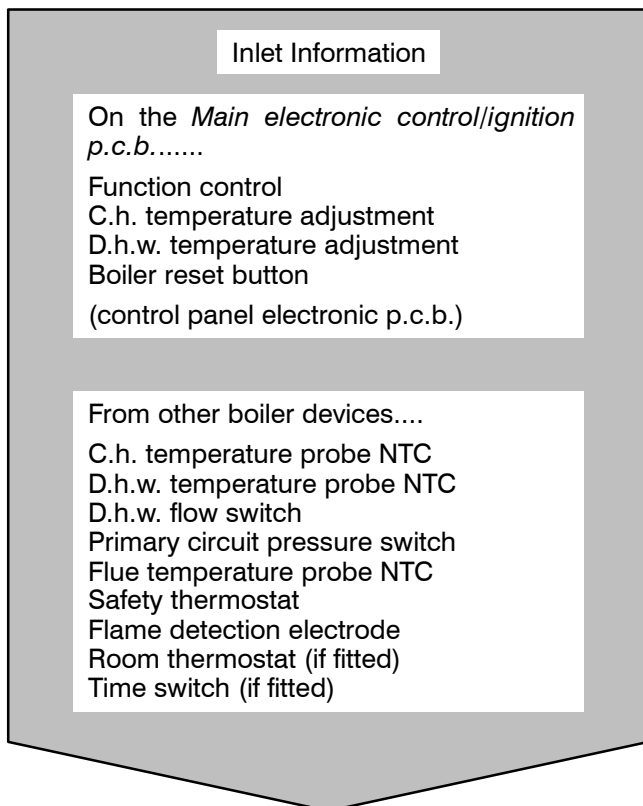

The fundamental function of the *Main electronic control/ignition p.c.b.* is that of controlling the boiler in relation to the external needs (i.e. heating the dwelling or heating the water for d.h.w. use) and operating in order to keep the temperature of the hydraulic circuits constant.

This is obviously possible within the useful power and maximum working temperature limits foreseen.

Generally, the *Main electronic control/ignition p.c.b.* receives inlet information coming from the boiler (the sensors) or from the outside (control panel electronic p.c.b., room thermostat, etc.), processes it and consequently acts with outlet commands on other components of the boiler (Fig. 9.1).

The *Main electronic control/ignition p.c.b.* is also a full sequence ignition device and does a sequence of operations (ignition cycle) which lead to the ignition of the gas at the burner

It checks the presence of the flame during the entire period in which it is activated and supplies the fan regulating its speed.

The *Main electronic control/ignition p.c.b.* has a **safety function** and any incorrect interventions or tampering can result in conditions of dangerous functioning of the boiler.

The *Main electronic control/ignition p.c.b.* can lock the functioning of the boiler (lock state) and stop its functioning up to the resetting intervention. The lock-out is signalled on the display of the control panel electronic p.c.b. and can be reset only by using the boiler reset button placed on the control panel electronic p.c.b. (see section 10.1).

Some components which are connected to the device can activate the lock state. The causes of a lock state could be:

- The intervention of the safety thermostat (overheat of the primary circuit).
- The intervention of the flue temperature probe (overheat of the combustion products).
- A fault on gas supply.
- Faulty ignition (faulty ignition electrodes, their wiring or connection).
- Faulty flame detection (faulty detection electrode, its wiring or connection).
- Faulty condensate drainage.
- Faulty gas valve (faulty on-off operators or not electrically supplied).
- Faulty *Main electronic control/ignition p.c.b.*

Other components like the primary circuit pressure switch can temporarily stop the ignition of the burner but allow its ignition when the cause of the intervention has stopped.

Fig. 9.13 and Fig. 9.14 show the sequence of the operations that are carried out at the start of every ignition cycle and during normal functioning.

9.2 Selection and adjustment devices

On the *Main electronic control/ignition p.c.b.* several selection, adjustment and protection devices are located. (Fig. 9.2).

Fig. 9.1

Some of these devices are directly accessible by the user (function control, temperature adjustment etc.) others, like the fuses, are accessible by removing the main electronic p.c.b. lid.

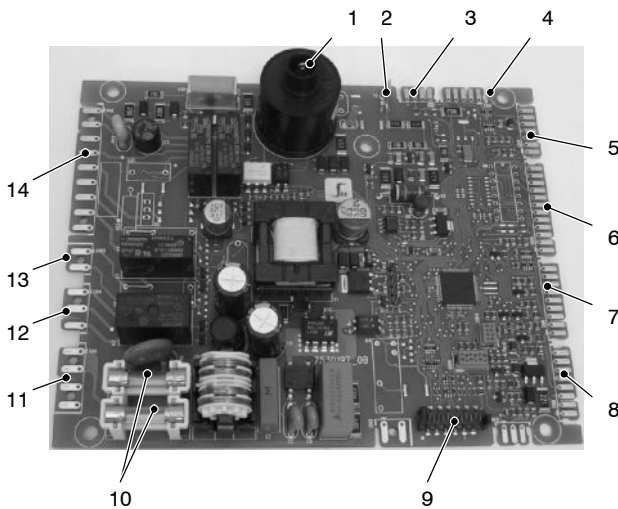



Fig. 9.2

- 1 Connector – ignition electrode.
- 2 Connector – flame detection electrode.
- 3 Connector – controller fan.
- 4 Connector – flue temperature probe NTC.
- 5 Connector – d.h.w. temperature probe NTC, d.h.w. flow switch and external temperature probe (optional).
- 6 Connector – Primary circuit pressure switch.
- 7 Connector – safety thermostat and c.h. temperature probe NTC.
- 8 Connector – remote control (optional).
- 9 Connector – display and function control / c.h. / d.h.w. temperature adjustment control panel p.c.b.
- 10 Fuse F1, F2 2A F
- 11 Connector – electric supply *Main electronic control/ignition p.c.b.*
- 12 Connector – 3way diverter valve.
- 13 Connector – electric supply control panel p.c.b.
- 14 Connector – gas valve, pump and fan.

9.3 Checking the temperature

The *Main electronic control/ignition p.c.b.* makes it possible to separately adjust the c.h. water flow temperature and d.h.w. outlet temperature.

The temperature of the water is converted into an electric signal by means of temperature probes.

The user, setting the desired temperature with the control panel p.c.b. key \triangle  ∇ or \triangle  ∇

If the power requested is lower than 40% of the maximum power output then control is achieved by switching ON the burner at minimum power, then switching OFF (ON/OFF function). If the power requested is higher, then the burner is switched ON at maximum power and will control by modulating to 40% of the maximum power output.

During the c.h. operation (Fig. 9.3), the signal coming from the c.h. temperature probe is compared to the signal given by the control panel p.c.b. through the adjustment made by the user (key \triangle  ∇). The result of such a comparison operates the fan speed thus regulating the gas flow rate and consequently changing the useful output of the boiler.

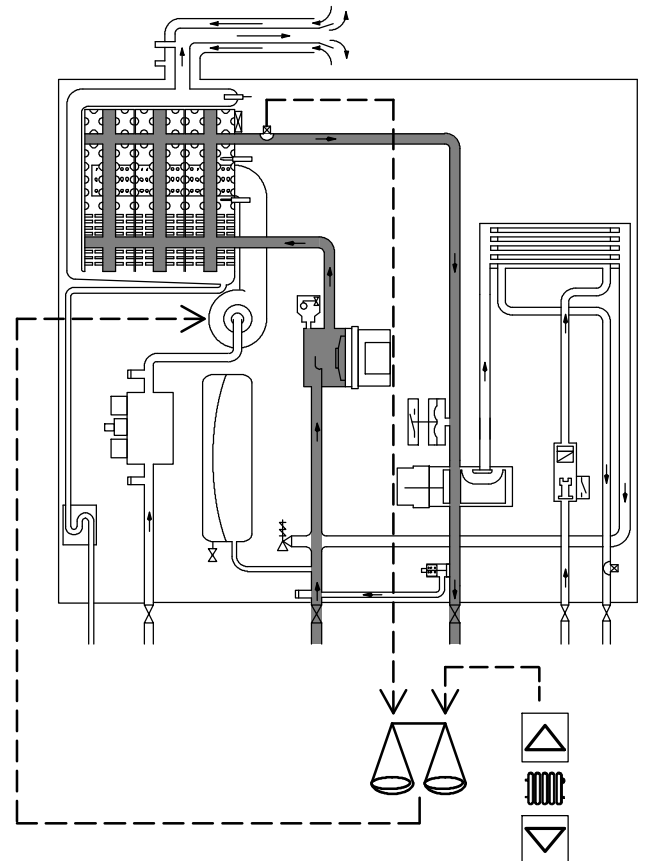



Fig. 9.3

When the boiler functions in d.h.w. (Fig. 9.4), the signal coming from the d.h.w. temperature probe is compared with the signal given by the control panel through the adjustment made by the user (key \triangle  ∇).

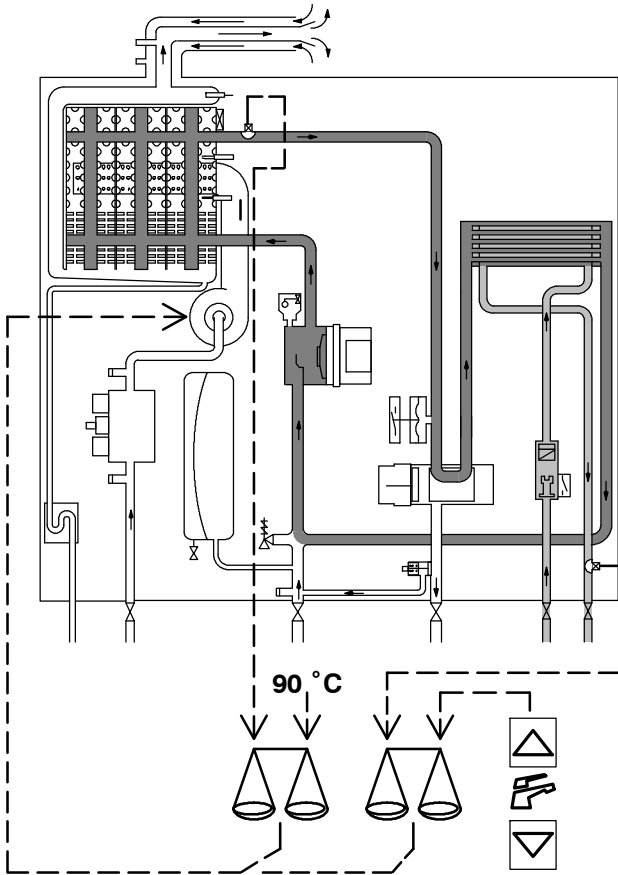

Fig. 9.4

Normally, the result of the comparison between these two signals directly operates the fan speed adjusting the useful output generated in order to stabilize the temperature of the exiting water.

If during the d.h.w. mode operation, the temperature of the primary circuit goes over 90°C, the useful output is automatically reduced so that the primary circuit cannot reach excessive temperatures.

The control sequences in ❄️ function and in ⚡ function are illustrated in detail in sections 9.7 and 9.8.

9.4 Setting the boiler control function modes

It is possible to select the various boiler control function modes hereafter named "parameters" by using the keys of the control panel p.c.b.

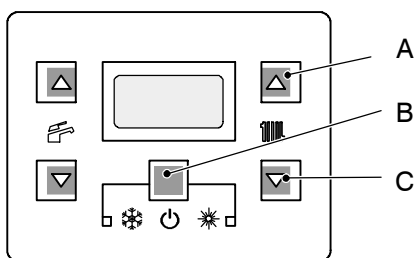

Fig. 9.5

- 1 To enter in the parameters setting mode press contemporary the 3 keys (A – B – C Fig. 9.5) for 10 second until the display shows Fig. 9.6

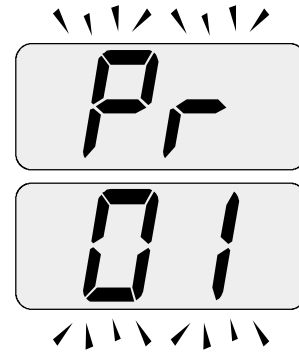

Fig. 9.6

- 2 To move trough the parameters press c.h. set keys (A or C Fig. 9.7)

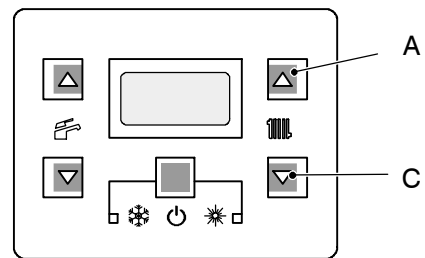

Fig. 9.7

- 3 The display shows Fig. 9.8

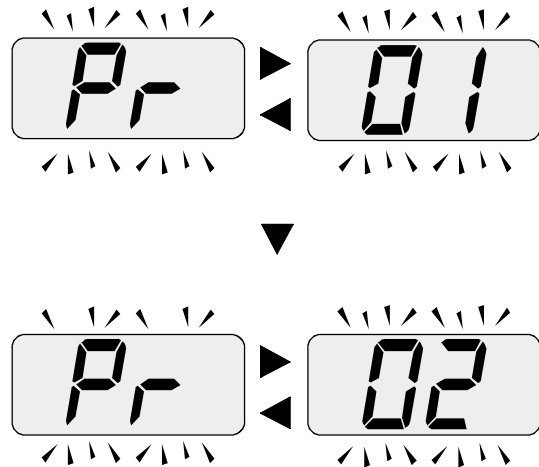

Fig. 9.8

- 4 To modify the parameter press contemporary the keys (A – B Fig. 9.9)

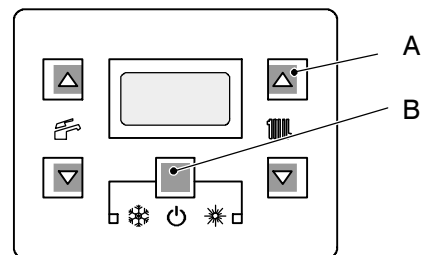

Fig. 9.9

- 5 To change the parameters press c.h. set keys (A or C Fig. 9.7)
- 6 To memorize the setting press the key (B Fig. 9.10)

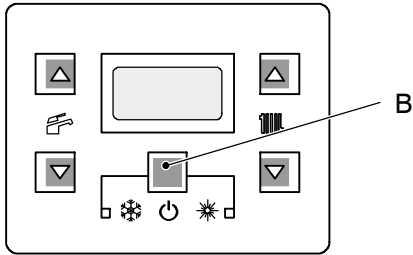

Fig. 9.10

7 To exit for setting without modifying the set press the keys (B – C Fig. 9.11)

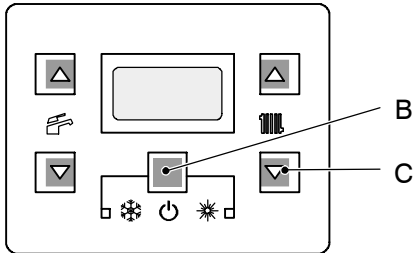

Fig. 9.11

To reset the boiler to the normal operation press contemporary the 3 keys (A – B – C Fig. 9.5) for 10 second.

The following table gives details of each parameter and the possible value that can be set.

Important: at the end of the setting operation it is important to fill/update the table in the installation manual see chapter COMMISSIONING section: Setting record.

PARAMETER	DIGIT	VALUES
Boiler type (to be updated with the complete range)	Pr 01	00 = No power Er 99 01 = Activ A 25C 02 = Activ A 30C. 03 = Activ A 35C. 06 = Activ A 18S 08 = Activ A 25S 09 = Activ A 30S
Not used	Pr 02	
Not used	Pr 03	
Not used	Pr 04	
Gas type	Pr 05	00 = G20 Natural 05 = G31 Propane
Not used	Pr 06	
C.h. flow max temperature °C	Pr 07	85 ÷ 45 (factory set 85 °C)
Factory parameters reset	Pr 08	00 = No reset 04 = All parameters return to factory set with the exclusion of Pr 01 and Pr 05 39 = All parameters return to factory set included Pr 01 and Pr 05

PARAMETER	DIGIT	VALUES
Chimney sweep function	Pr 09	00 = No chimney sweep fun (factory set) 01 = Low power sweep-test 04 = C.h. power sweep-test 07 = D.h.w. power sweep-test
C.h. reignition frequency	Pr 10	00 ÷ 99 (0 ÷ 600 sec.) (factory set 30 = 3 minutes)
C.h. pump post-circulation	Pr 11	00 ÷ 99 (0 ÷ 600 sec.) (factory set 10 = 1 minute)
Max. useful output in c.h. mode	Pr 12	00 ÷ 99 (0 ÷ 100%) factory set: 74 = Activ A 25C 79 = Activ A 30C. 86 = Activ A 35C. 99 = Activ A 18S 99 = Activ A 25S 99 = Activ A 30S
C.h. pump working type	Pr 13	00 = Depends on room thermostat (factory set) 04 = Always running
Ignition power	Pr 14	00 ÷ 99 (0 ÷ 100%) factory set: Natural gas (G20) 20 = Activ A 25C 30 = Activ A 30C. 26 = Activ A 35C. 32 = Activ A 18S 38 = Activ A 25S 30 = Activ A 30S Propane (G31) 31 = Activ A 25C 30 = Activ A 30C. 26 = Activ A 35C. 49 = Activ A 18S 37 = Activ A 25S 31 = Activ A 30S
K value (external probe diagram)	Pr 15	01 (=0,1) ÷ 60 (=6,0) K value factory set: 00 = Off
Not used	Pr 16	
D.h.w. burner turn off function	Pr 17	00 = Burner off at fixed d.h.w. = 65 °C (factory set) 01 = Brurner off at set point +5 °C
NTC on the c.h. return	Pr 18	00 = Probe not present 01 = Probe present

PARAMETER	DIGIT	VALUES
Not used	Pr 19	
Not used	Pr 20	
Not used	Pr 21	
Not used	Pr 22	
Not used	Pr 23	
Not used	Pr 24	
Not used	Pr 25	
Not used	Pr 26	
C.h. minimum set-point	Pr 27	25 ÷ 45 (factory set 25 °C)

Tab. 9.1

9.5 Checks

✓ Check that the fuses are complete

If the *Main electronic control/ignition p.c.b.* does not supply any device (pump, fan, etc.) check that the fuses 10 (Fig. 9.2) are complete.

If a fuse has blown replace it with one that has the same characteristics after having identified the reason for failure.

✓ Lock sequence

Start the boiler until the burner is ignited.

With the burner firing, interrupt the gas supply. The *Main electronic control/ignition p.c.b.* must carry out four complete ignition cycles and then, after about 4 minutes, goes to lock-out state.

Switch off and on the electricity supply to the boiler, by means of the fused spur isolation switch, the device must not unlock and the burner must not turn on

9.6 Removal of the electronic control p.c.b

⚡ **Warning: isolate the boiler from the mains electricity supply before removing any covering or component.**

When replacing the *Main electronic control/ignition p.c.b.* all parameters must be correctly checked / adjusted accordingly with the values noted in table in the installation manual see chapter COMMISSIONING section: Setting record (for information on parameters see also section 9.4).

- 1 Remove all the body panels (see section 2.2).
- 2 Gain access to the parts located inside the Main electronic p.c.b. box as explained in the section 2.4 of this manual.
- 3 Remove all the wiring connected to the *Main electronic control/ignition p.c.b.*

- 4 Delicately flex the hooks *D* in the directions indicated (Fig. 9.12) in order to release the circuit from the box.
- 5 Remove the *Main electronic control/ignition p.c.b.*

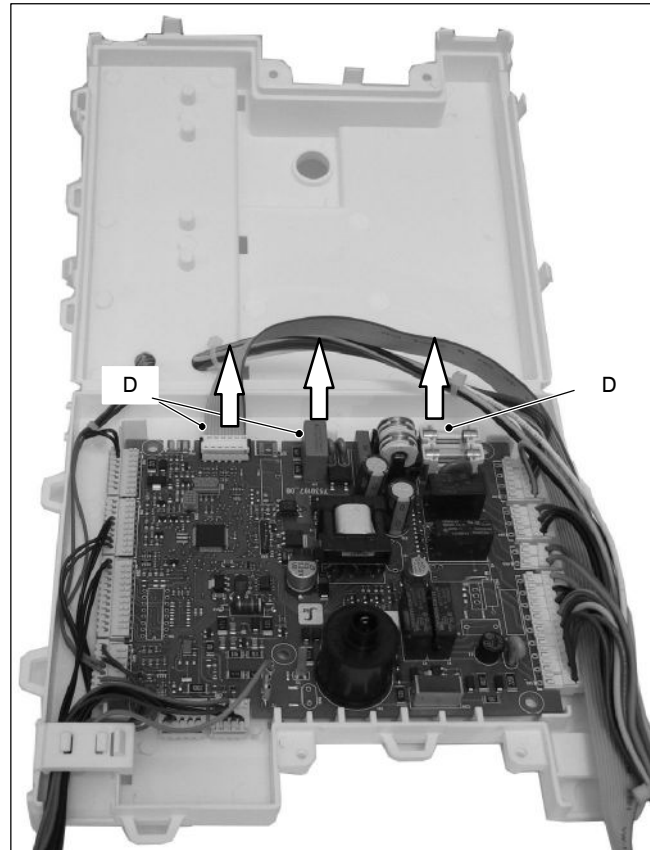

Fig. 9.12

- 6 Re-assemble the *Main electronic control/ignition p.c.b.* following the removal procedures in the reverse order.

Important

When re-assembling the *Main electronic control/ignition p.c.b.*:

- 7 It is not necessary to utilise static protections but it is advisable to ensure that the pcb is handled with care and held at the edges and with clean dry hands.

Attention

After installing the *Main electronic control/ignition p.c.b.* properly set the parameters.



Warning: After cleaning or replacement as detailed above, if it deemed necessary to undertake a combustion analysis, refer to the appropriate chapter *Maintenance* of the installation instructions manual.

9.7 Thermal control in the "☀" mode

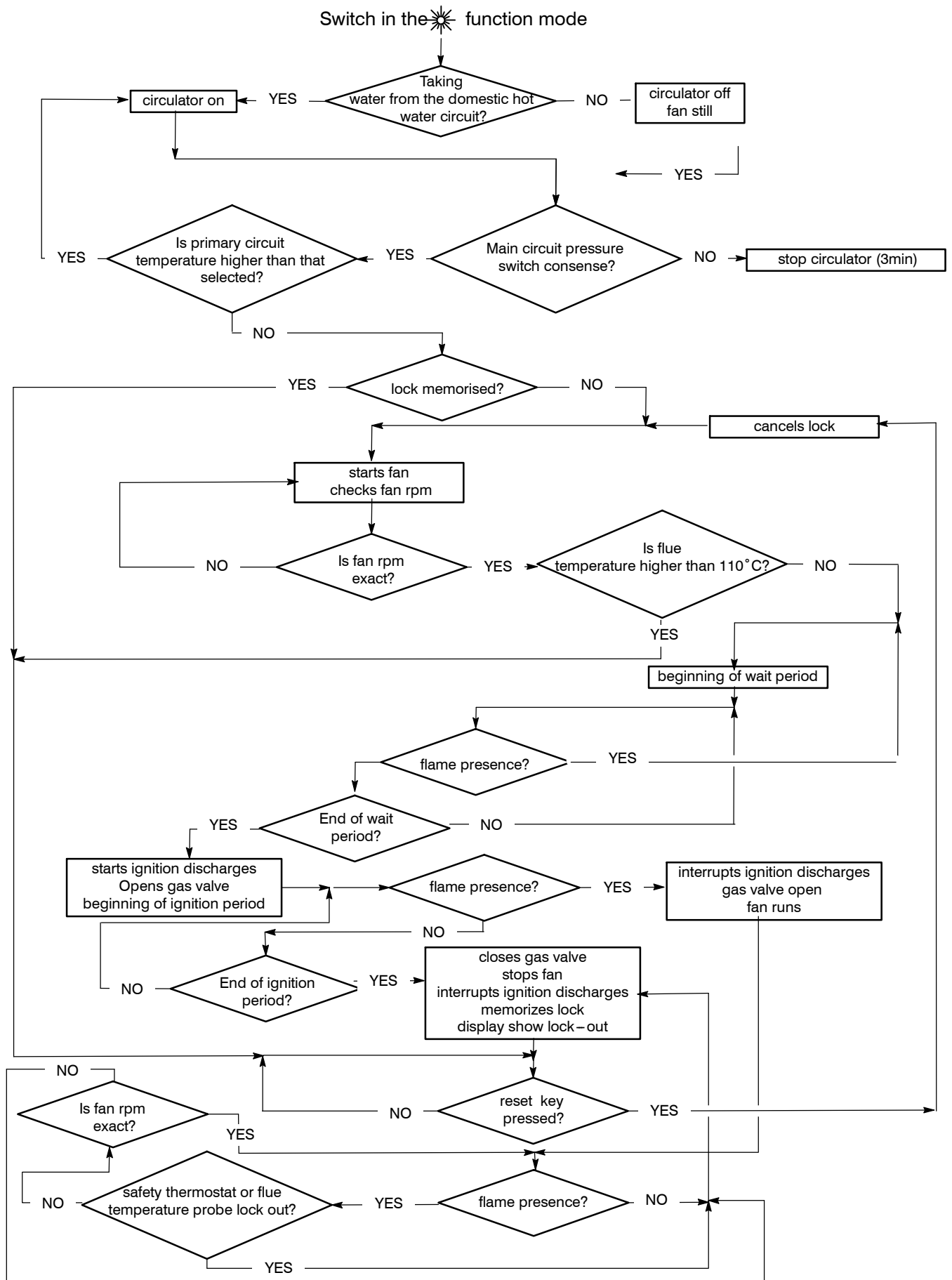

Fig. 9.13

9.8 Thermal control in the "❄️" mode

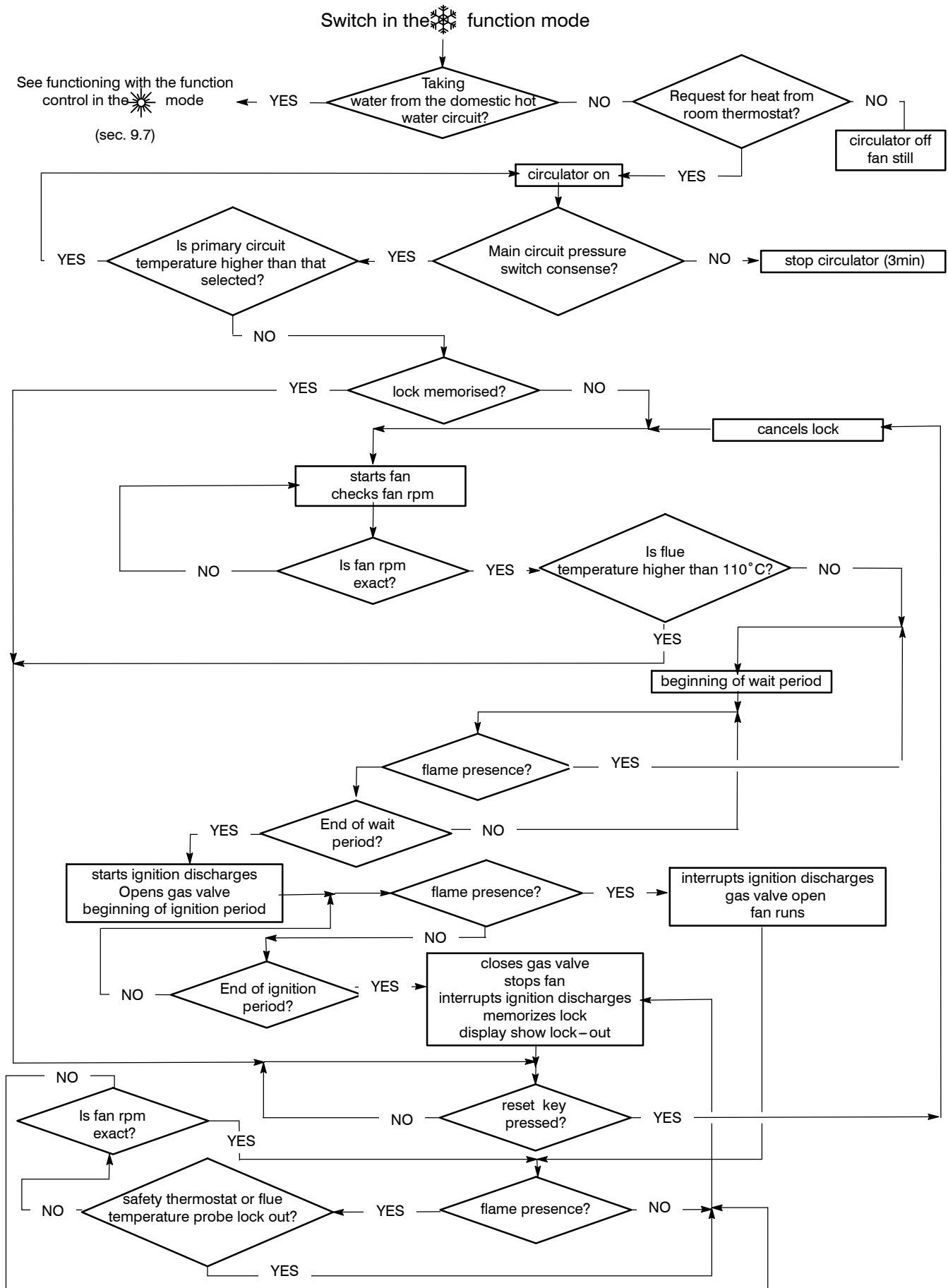

Fig. 9.14

10 Control panel electronic p.c.b.

10.1 Function

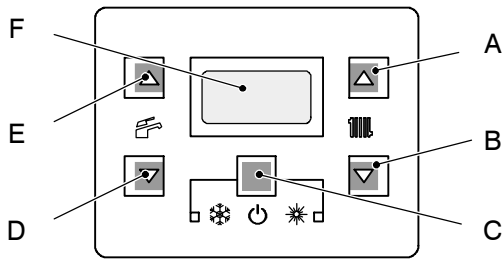

Fig. 10.1

- A) C.h. temperature increase key
- B) C.h. temperature reduce key
- C) Reset/Stand-by/Winter/Summer key
- D) D.h.w. temperature reduce key
- E) D.h.w. temperature increase key
- F) Display

The *Control panel electronic p.c.b.* can give to the service 3 levels of informations:

- Normally information (see the installation manual chapter APPLIANCE DESCRIPTION section LCD general features.
- Info modality
- Function modes setting modality

10.2 Info modality

The INFO mode allows the display of some information on the boiler functioning status. In case of malfunctioning of the boiler, it may be useful to communicate such information to the Authorised Service Centre Engineer so that the causes can be understood.

In order to access the INFO mode, press keys A and C (Fig. 10.1) at the same time until the letter **di** appears on the display that alternates with a code (Fig. 10.2).



Fig. 10.2

To scroll the values press B (reduce) and A (increase) keys (Fig. 10.1). In order to exit the INFO mode, hold keys A and C (Fig. 10.1) pressed at the same time.

The following table gives details of each parameter and the possible value that can be show.

Description	Parameter	Value
External temperature °C (if fitted)	d1	-5
K value (external probe diagram) (the value is x 10)	d2	12
Offset (Transaltion of K diagram ± 15°C)	d3	-10
C.h. temperature °C (calculated by external sensor)	d4	66
C.h. flow temperature °C	d5	78
C.h. return temperature °C (if fitted)	d6	44
D.h.w. temperature °C	d7	40
Flue temperature °C	d8	67
Fan speedy (the value has to be x 100 = 4400 rpm)	d9	44
SW version BC (burner control)	dc	01
SW version MB (main board)	dd	03

Tab. 10.1

10.3 Function modes setting modality

It is possible to select the various boiler control function modes hereafter named "parameters" by using the keys of the control panel p.c.b.

During the function modes setting, the boiler does not operate.

To get in function modes setting modality see section 9.4

10.4 Removal of the control panel electronic p.c.b

Warning: isolate the boiler from the mains electricity supply before removing any covering or component.

- 1 Remove all the body panels (see section 2.2).
- 2 Gain access to the parts located inside the *Control panel electronic p.c.b.* as explained in the section 2.3 of this manual.
- 3 Remove all the wiring A connected to the *Control panel electronic p.c.b.* (Fig. 10.3).

Control panel electronic p.c.b.

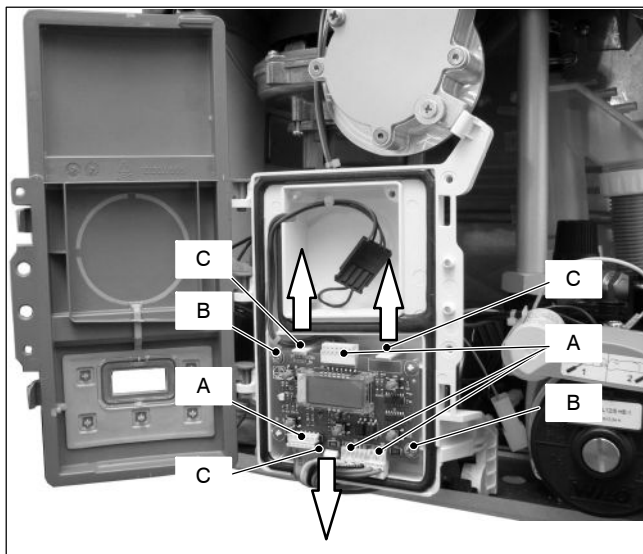

Fig. 10.3

- 4 Unscrew the screws *B*
- 5 Delicately flex the hooks *C* in the directions indicated (Fig. 10.3) in order to release the circuit from the box.
- 6 Remove the *Control panel electronic p.c.b.*
- 7 Reassemble the *Control panel electronic p.c.b.* carrying out the removal operations in the reverse order.

11 Gas valve

11.1 Function

The Gas valve A in Fig. 11.1 controls the gas inflow to the boiler burner.

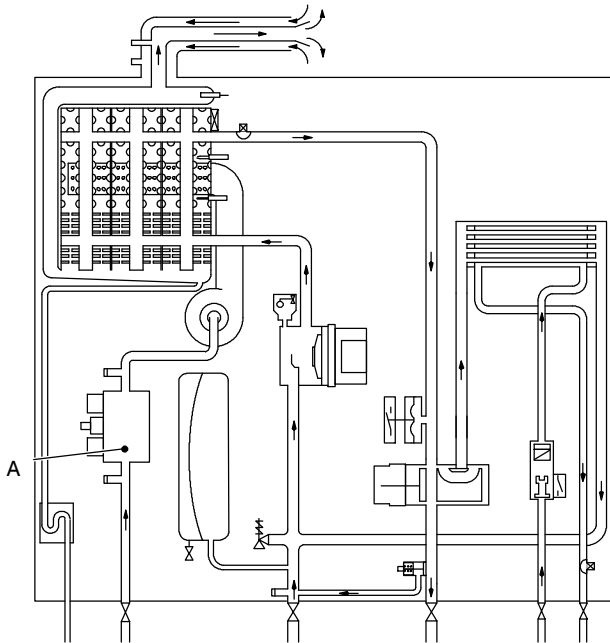

Fig. 11.1

By means of an electric command given to the on-off operators the passage of the gas through the Gas valve can be opened or closed.

11.2 Description of the parts (Fig. 11.2)

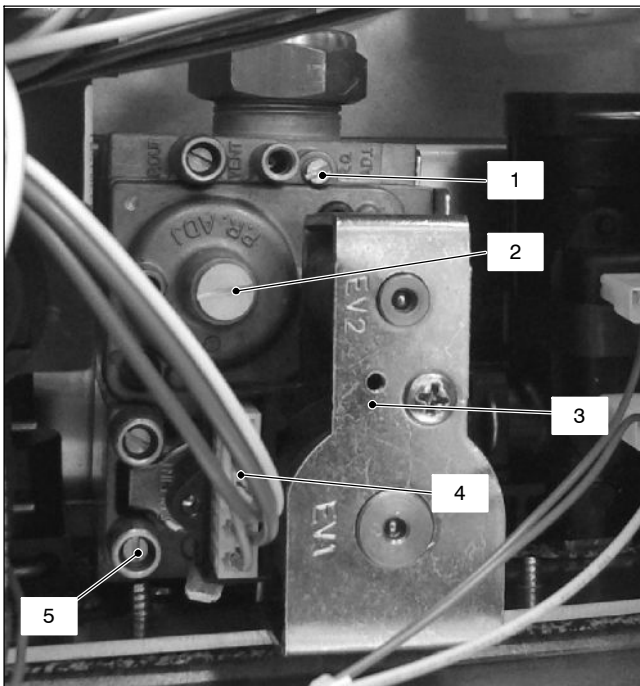

Fig. 11.2

- 1 Maximum gas pressure adjustment
- 2 Minimum gas pressure adjustment
- 3 On-off operators
- 4 On-off operators electric connector

- 5 Gas valve inlet pressure test point

11.3 Adjustment

Warning: isolate the boiler from the mains electricity supply before removing any covering or component.

Check the supply pressure before making any adjustment to the gas valve.

- 1 Close the gas inlet valve.
- 2 Remove the front panel of the case and lower the control panel (see sections 2.2 and 2.3).
- 3 Loosen the internal screw on the Inlet Pressure Test Point 5 (Fig. 11.2) of the Gas valve and connect a pressure gauge using a suitable hose.
- 4 Open the gas inlet valve.
- 5 Turn on the electricity supply to the boiler, switching on the fused spur isolation switch.
- 6 Set the boiler in c.h. / d.h.w. function as illustrated in Fig. 11.3

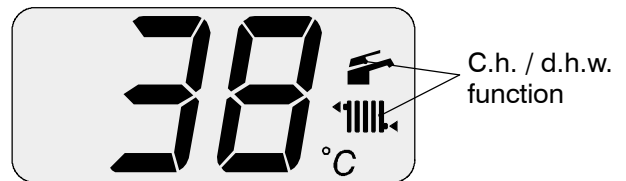

Fig. 11.3

- 7 Open at least one hot water tap fully.
- 8 Read the inlet pressure value and ensure that it is within the limits given in the table *Gas supply pressures*, of the user/installation manual. If it does not comply with the required pressure check the gas supply line and governor for faults and/or correct adjustment.
- 9 Switch off the boiler **close the gas inlet valve** and close the water tap.
- 10 Disconnect the pressure gauge and close the Inlet Pressure Test Point 5 (Fig. 11.2).

Gas valve adjustment

- 11 Fit the probe of the flue analyser in the flue exhaust sampling point located on the exhaust pipes of the boiler (Fig. 11.4).

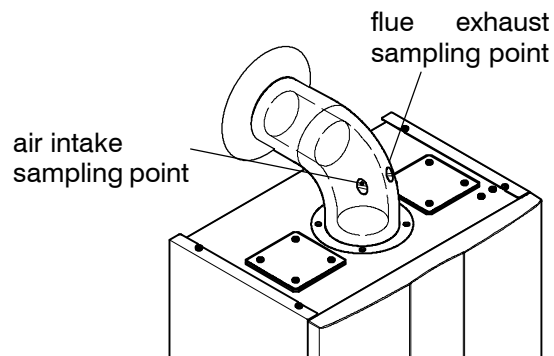

Fig. 11.4

- 12 Turn on the boiler, switching on the fused spur isolation switch.
- 13 Open the gas inlet valve.

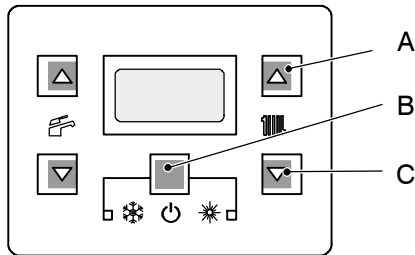

Fig. 11.5

- 14 To enter in the parameters setting mode press contemporary the 3 keys (A – B – C Fig. 11.5) for 10 second until the display shows Fig. 11.6



Fig. 11.6

Adjusting minimum gas valve setting

- 15 Press keys A and C (Fig. 11.5) at the same time until the display shows the letters **LP** that alternate with the heating water temperature value (e.g.**45**), indicating the activation of the "chimney sweep function" at minimum output (Fig. 11.7).

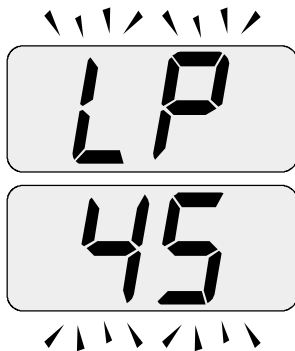

Fig. 11.7

- 16 Open at least one hot water tap fully.
 17 Allow the analyser to give a stable reading.
 18 Read the CO₂ % value.
 It should be between:

Model	Type gas	CO ₂ % value (range)
Activ A 25C Activ A 30C. Activ A 35C. Activ A 25S Activ A 30S	Natural (G20)	8,6 – 9,2
	Propane (G31)	9,5 – 10,1
Activ A 18S	Natural (G20)	8,6 – 9,2
	Propane (G31)	9,7 – 10,3

Tab. 11.1

To adjust the CO₂ % value remove the brass plug by unscrewing it and rotate the Allen key screw ø 4 mm (2 – Fig. 11.2) (by rotating it clockwise the CO₂ % increases).

Checking the maximum gas valve setting

- 19 Press key A to vary the output in chimney sweep mode: when the display shows the letters **cP** that alternate with the heating water temperature value (e.g.**60**), the "chimney sweep function" is at maximum output in heating mode (Fig. 11.8);

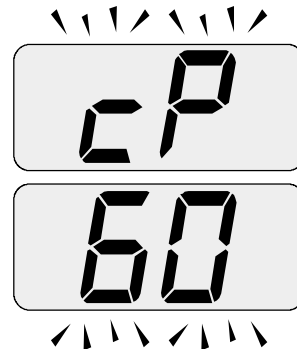

Fig. 11.8

- 20 Press further key A to vary again the output in chimney sweep mode: when the display shows the letters **dP** that alternate with the heating water temperature value (e.g.**60**), the "chimney sweep function" is at maximum output in domestic hot water mode" (Fig. 11.9);

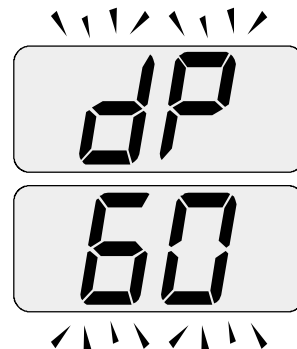

Fig. 11.9

- 21 Allow the analyser to give a stable reading.
 22 Read the CO₂ % value.
 It should be between:

Model	Type gas	CO ₂ % value (range)
Activ A 25C Activ A 30C. Activ A 35C.	Natural (G20)	9,3 – 9,9
	Propane (G31)	10,3 – 10,9
Activ A 18S	Natural (G20)	9,3– 9,9
	Propane (G31)	10,2 – 10,8
Activ A 25S Activ A 30S	Natural (G20)	9,2– 9,8
	Propane (G31)	10,3 – 10,9

Tab. 11.2

To adjust the CO₂ % value rotate screw (1 – Fig. 11.2) (by rotating it clockwise the CO₂ % decreases).

- 23 Press keys A – B – C (Fig. 11.5) at the same time again to exit the "chimney sweep mode" and return to the previously set boiler status (Fig. 11.10)

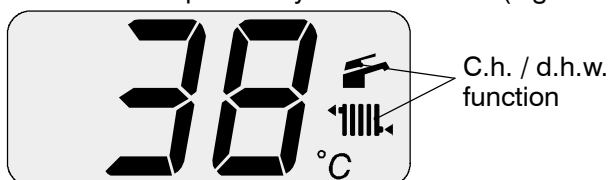

Fig. 11.10

- 24 Switch off the boiler and turn off the hot water tap(s).
- 25 Close the air–flue sampling points.
- 26 After adjustment fit the protective brass plug (2, Fig. 11.2).

Important: after the gas pressure checks and any adjustment operations, all of the test points must be sealed.

11.4 Checks

Warning: isolate the boiler from the mains electricity supply before removing any covering or component.

- ✓ Check the on–off operators coils
- 1 Remove the front panel of the case.
 - 2 Disconnect the electrical connector 4 (Fig. 11.2).
 - 3 Measure the electrical resistance between the connector pins of the on–off operators as illustrated in Fig. 11.11.

ON–OFF Operator
approx. 6 400 Ω*

ON–OFF Operator
approx. 920 Ω*

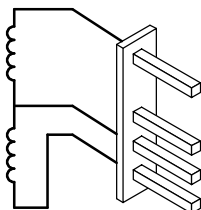

* at ambient temperature.

Fig. 11.11

11.5 Removal of the gas valve

Warning: isolate the boiler from the mains electricity supply before removing any covering or component.

- 1 Remove the front panel of the case as explained in the section 2.3 of this manual.
- 2 Disconnect the connector *D* (Fig. 11.12).

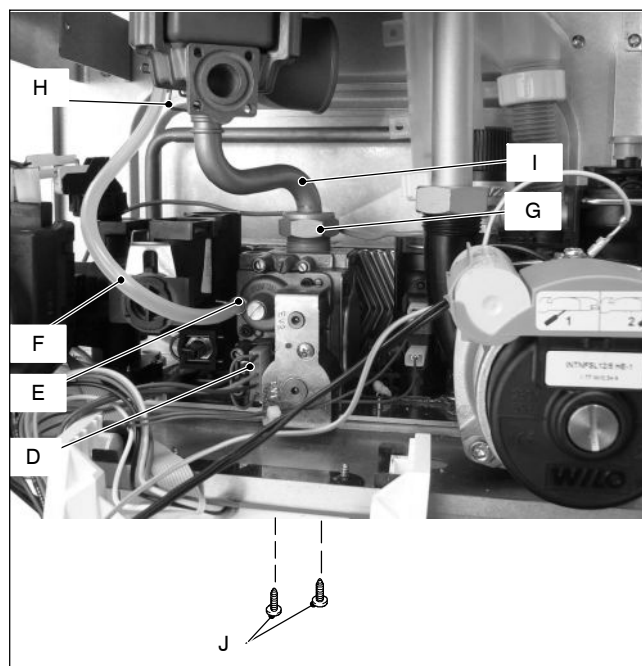

Fig. 11.12

- 3 Turn off the gas supply and disconnect the gas isolation cock connector from the inlet port of the gas valve.
- 4 Using pliers, remove the spring *E* and the rubber pipe *F* (Fig. 11.12).
- 5 Unscrew the connector *G* (Fig. 11.12), remove the fixing fork *H* and remove the pipe *I*.
- 6 Unscrew the screws *J* and remove the valve (Fig. 11.12).
- 7 Reassemble the valve carrying out the removal operations in reverse order.

Warning: Be careful not to damage the OR gasket of the gas pipe when inserting the pipe in the air box (air/gas mixer).

Before to fit a new valve it is advisable to pre–set it as follows.

- 8 Remove the brass plug and turn the plastic screw inside it fully clockwise until it stops. Do not over-tight.
- 9 Turn it counter–clockwise 2 and 3/4 turns.
- 10 Adjust the gas valve using the flue analyser as described in section 11.3.

After any service operation on the components of the gas circuit check all the connections for gas leaks.

Warning: After cleaning or replacement as detailed above, it is deemed necessary to undertake a combustion analysis as detailed in chapter 11.3 section 11.

12 Primary circuit flow switch

12.1 Function

The Primary circuit flow switch (A in Fig. 12.1) function is to check the presence of water in the primary hydraulic circuit and that the pressure is above the minimum.

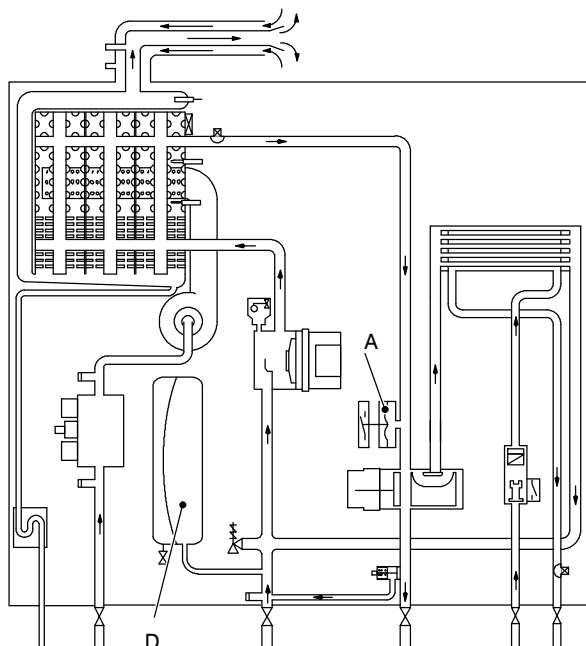

Fig. 12.1

This device is connected to the main electronic control p.c.b. and if, it does not activate the control board will indicate that a fault condition (see section 4.1 of this manual) has occurred.

12.2 Checks

Warning: isolate the boiler from the mains electricity supply before removing any covering or component.

Electrical check

It is possible to verify the general operation of the switch by measuring the electric resistance between the contacts C. and N.O. of the switch.

- 1 Measure the electrical resistance between the tabs marked C. and N.O. (Fig. 12.2). The contact must close (resistance zero) with c.h. pressure of 0,35 bar or higher.

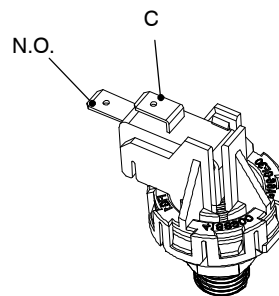

Fig. 12.2

12.3 Removal

Warning: isolate the boiler from the mains electricity supply before removing any covering or component.

- 1 Remove the front and right hand side panels of the case, turn off the flow and return isolation valves and empty the primary circuit.
- 2 Remove the fixing spring B (Fig. 12.3) and remove the primary circuit pressure switch A.
- 3 Disconnect the connectors C (Fig. 12.3).

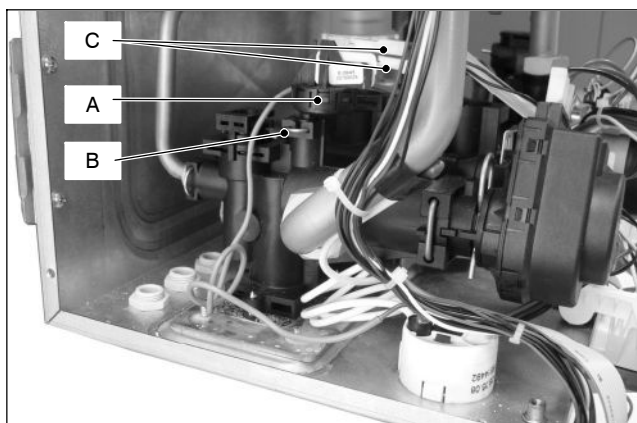

Fig. 12.3

- 4 Reassemble the primary circuit pressure switch in reverse order of removal.

Warning: to lubricate the O-ring gaskets exclusively use a silicone base grease compatible to be in contact with foods and approved by the local water Authorities.

13 Expansion vessel and pressure gauge

13.1 Function

The Expansion vessel (D in Fig. 12.1) function is to allow for the volume expansion of the c.h. circuit water due to the temperature rise.

13.2 Checks

- 1 Turn off the flow and return isolation valves and empty the primary circuit of the boiler.

- 2 Remove the protective cap *E* (Fig. 13.1) from the valve on the top of the expansion vessel and connect a suitable air pressure gauge.

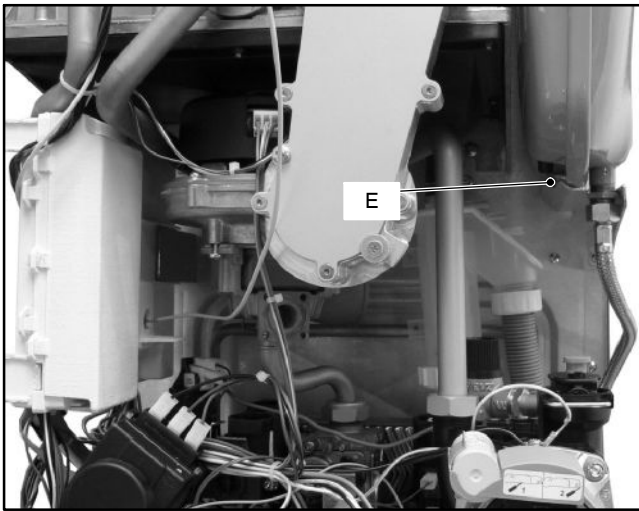

Fig. 13.1

- 3 Check the pre-load pressure and refer to the section *Expansion vessel* in the *User manual and installation instructions* for the correct value.

13.3 Removal of the expansion vessel

Warning: isolate the boiler from the mains electricity supply before removing any covering or component.

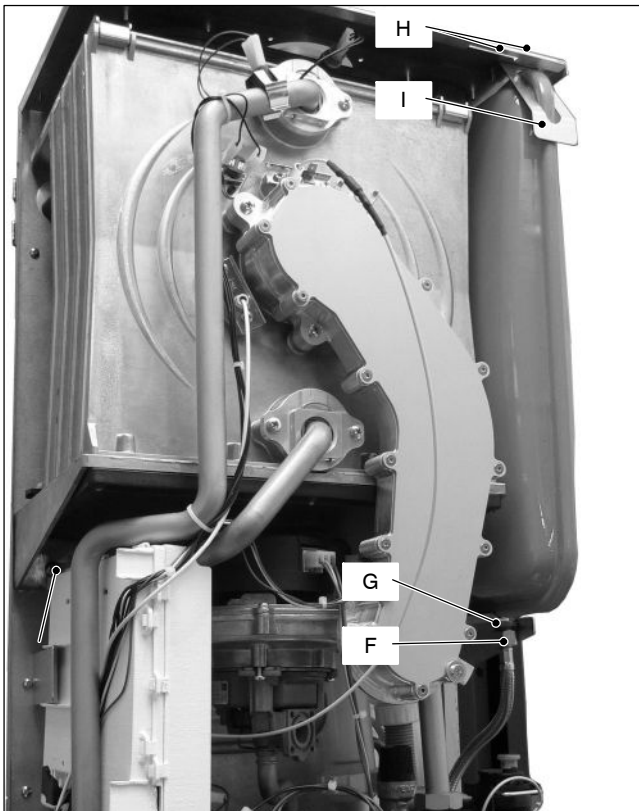

Fig. 13.2

- 1 Remove the front and right hand side panels of the case, turn off the flow and return isolation valves and empty the primary circuit.
- 2 Completely unscrew the connection *F*, the lock-nut *G* (Fig. 13.2).
- 3 Unscrew the screws *H* and remove the bracket *I* (Fig. 13.2).
- 4 Remove the expansion vessel from the front of the boiler.
- 5 Re-assemble the parts in reverse order of removal.

13.4 Removal of the pressure gauge

- 1 Remove the front and side panels of the case, turn off the flow and return isolation valves and empty the primary circuit.
- 2 Remove the fork *J* (Fig. 13.3).

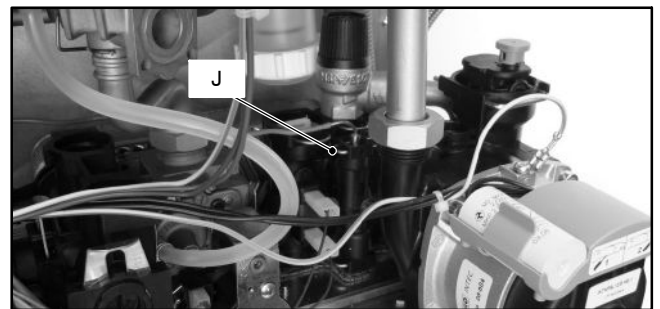
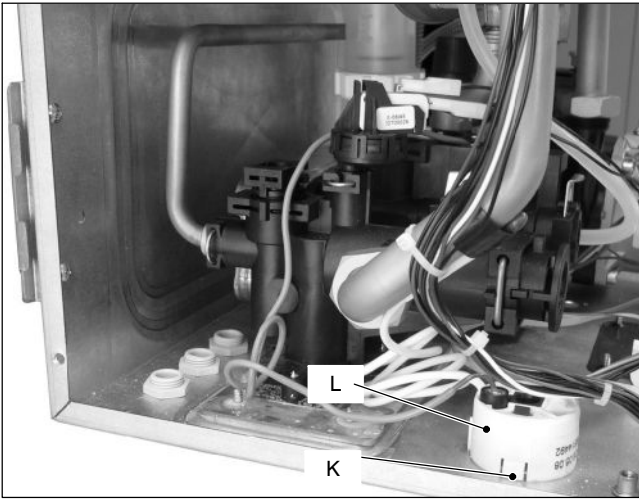

Fig. 13.3 Combi



Fig. 13.4 C.h. only

- 3 Squeeze the tabs *K* to release the pressure gauge *L* and remove it.



- 4 Re-assemble the parts in reverse order of removal.

Fig. 13.5

14 D.h.w. flow switch, filter and flow limiter

14.1 Function

The d.h.w. flow switch *A* in Fig. 14.1 is a device that generates an electrical signal when hot water is drawn.

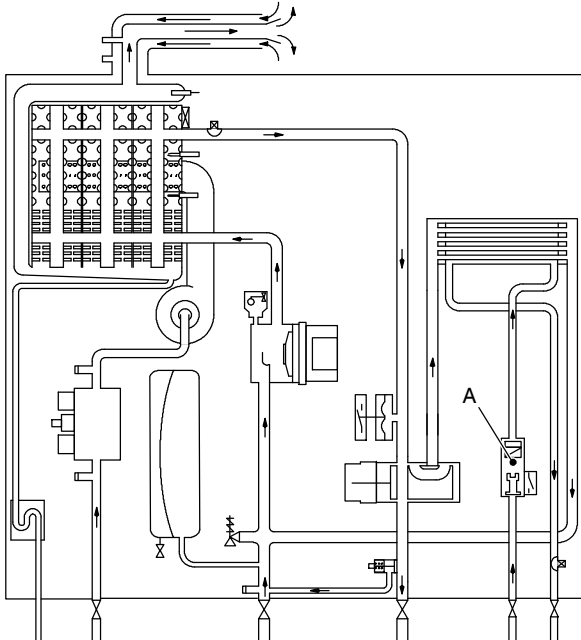

Fig. 14.1

When the flow rate through the d.h.w. circuit reaches about 2,5 litres/min', the float 5 (Fig. 14.3) is dragged upwards and the magnetic in it, getting closer to the sensor 8 closes the electric contact.

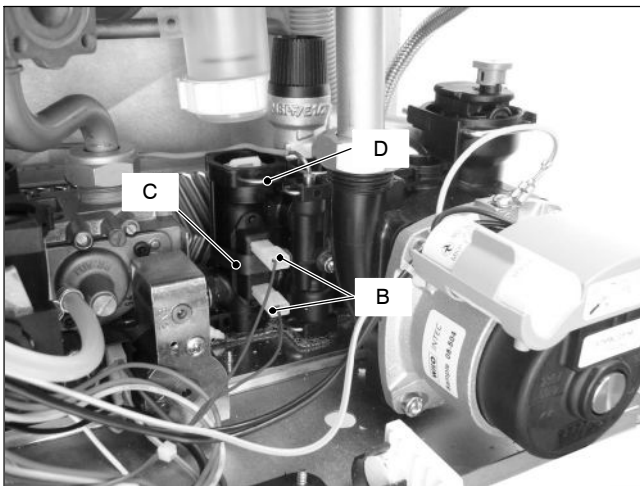

Fig. 14.2

14.2 Description and location of parts (Fig. 14.3)

- 1 Flow switch plug
- 2 O-ring
- 3 Flow limiter (Activ A 30C. Activ A 35C. optional accessory)
- 4 Body
- 5 Float

- 6 Filter
- 7 Sensor holder spring
- 8 Sensor

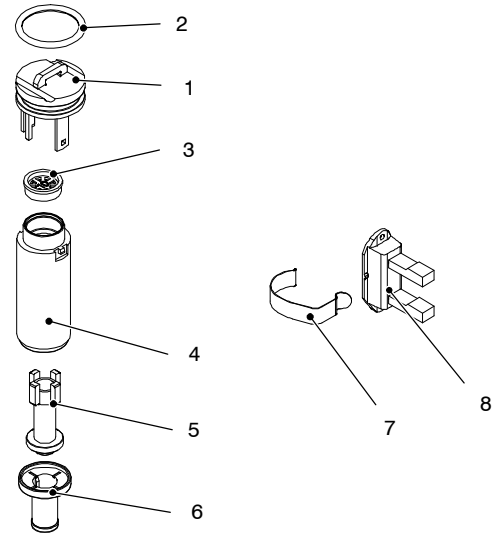

Fig. 14.3

14.3 Checks

Warning: isolate the boiler from the mains electricity supply before removing any covering or component.

➤ Sensor operation

- 1 Remove the front panel of the case.
- 2 Measure the electrical resistance at the leads of the sensor. Without water being drawn, the contact must be open. By opening a hot water tap the contact must be close (electrical resistance zero Ω).

14.4 Removal of the sensor

Warning: isolate the boiler from the mains electricity supply before removing any covering or component.

- 1 Remove the front panel of the case.
- 2 Disconnect the connectors *B* and remove the sensor holder spring *C* (Fig. 14.2).
- 3 Remove the sensor.

14.5 Removal of the flow switch group and d.h.w. circuit filter

Warning: isolate the boiler from the mains electricity supply before removing any covering or component.

- 1 Remove the front panel of the case and empty the d.h.w. circuit.
- 2 Remove the sensor (see section 14.4).
- 3 Remove the fork *D* and pull up the flow switch plug 1 with the help of a screwdriver.
- 4 To remove the filter from the flow switch group separate the filter 6 from the body 4 (Fig. 14.3) by levering it.
- 5 Reassemble the parts following the removing sequence in reverse order.

14.6 Flow limiter

The Activ A 25C model is factory fitted with a 10 litres/min. flow limiter.

The Activ A 30C. model is factory fitted with a 12 litres/min. flow limiter.

The Activ A 35C. model is factory fitted with a 14 litres/min. flow limiter.

The following sizes are available:

If the flow rate of the d.h.w. circuit is still too high, it is possible to limit it by replacing the flow limiter. The following sizes are available:

Nominal flow rate (litres/min)	Colour
10	Blue
12	Red
14	Pink

To install the flow limiter:

- 1 Remove the flow switch group as explained in the section 14.5.
- 2 Separate the flow switch plug 1 from the body 4 levering with a screwdriver one of the two hooks.

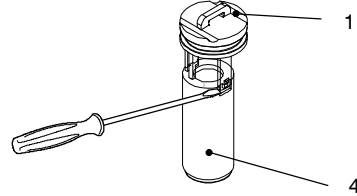

Fig. 14.4

- 3 Insert the flow limiter 3 as shown in Fig. 14.3
- 4 Reassemble the group following the above sequence in reverse order.

15 Temperature probe

15.1 Function

The Temperature probe has the function of converting the temperature of the water in the hydraulic circuit where it is installed into an electrical signal (resistance).

The relation between temperature and electrical resistance is stated in Fig. 15.1.

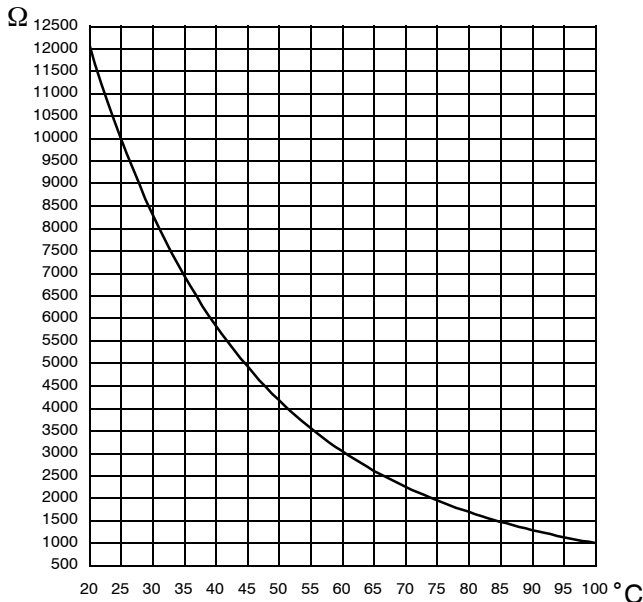

Fig. 15.1

On the boiler there are two Temperature probes. One on the output of the primary condensing heat exchanger (c.h. Temperature probe) *A* in Fig. 15.2 and Fig. 15.3; one on the output of the d.h.w. heat exchanger (d.h.w. Temperature probe) *B* in Fig. 15.2 and Fig. 15.4.

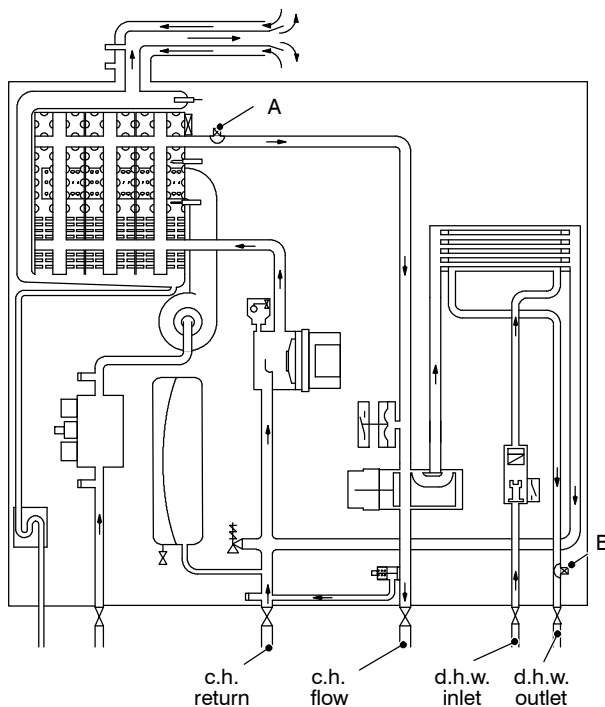

Fig. 15.2

15.2 Checks

✓ Temperature–resistance relationship

⚡ **Warning: isolate the boiler from the mains electricity supply before removing any covering or component.**

Disconnect the cable from the Temperature probe.

Measure the temperature of the pipe *C* (only c.h. Temperature probe) where the Temperature probe is located and check the electrical resistance according to the graph in Fig. 15.1.

15.3 Removal of the c.h. Temperature probe

⚡ **Warning: isolate the boiler from the mains electricity supply before removing any covering or component.**

- 1 Remove all the case panels.
- 2 Empty the primary circuit of the boiler.
- 3 Remove the electric connector *D* and remove the c.h. Temperature probe *A* – Fig. 15.3
- 4 Reassemble the c.h. Temperature probe carrying out the removal operations in reverse order.

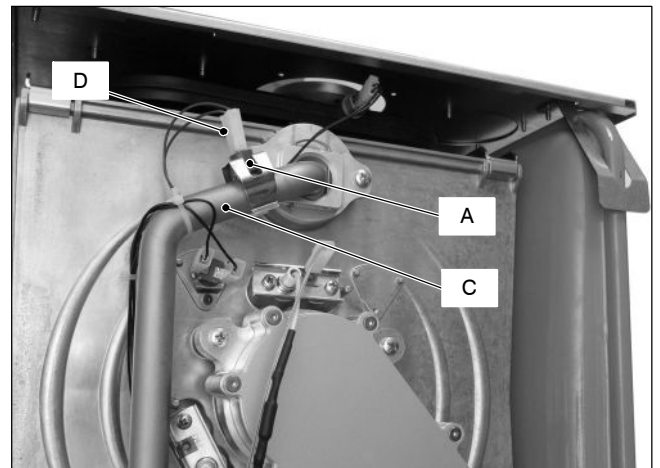

Fig. 15.3

15.4 Removal of the d.h.w. Temperature probe

⚡ **Warning: isolate the boiler from the mains electricity supply before removing any covering or component.**

- 1 Remove the front panel of the case and lower the control panel.
- 2 Empty the d.h.w. circuit of the boiler.
- 3 Remove the electric connector *E*
- 4 Remove the fork *F* and pull the d.h.w. Temperature probe *B* – Fig. 15.4
- 5 Reassemble the d.h.w. Temperature probe carrying out the removal operations in reverse order.

🔧 **Warning: to lubricate the O–ring gaskets exclusively use a silicone base grease compatible to be in contact with foods and approved by the local water Authorities.**

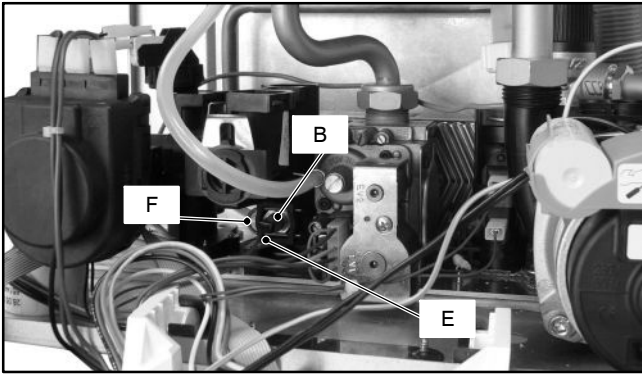

Fig. 15.4

16 By-pass valve

16.1 Function

The By-pass valve A in Fig. 16.1 is located between the c.h. water flow and return and its function is that of guaranteeing a minimum flow across the primary heat exchanger if the circulation across the c.h. system is completely closed.

The By-pass valve is fitted on the rear side of the diverter group.

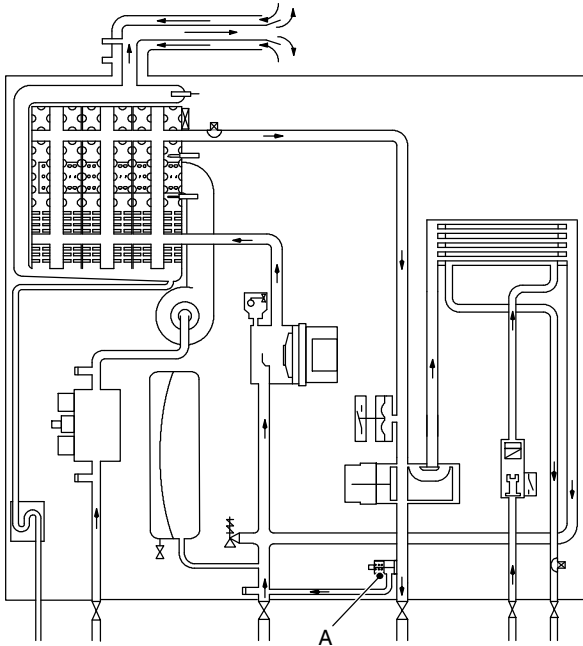

Fig. 16.1

16.2 Removal

Warning: isolate the boiler from the mains electricity supply before removing any covering or component.

- 1 Remove all the case panels.
- 2 Empty the primary circuit of the boiler.
- 3 Remove the locking plate B and pull up the by-pass valve A (Fig. 16.2).

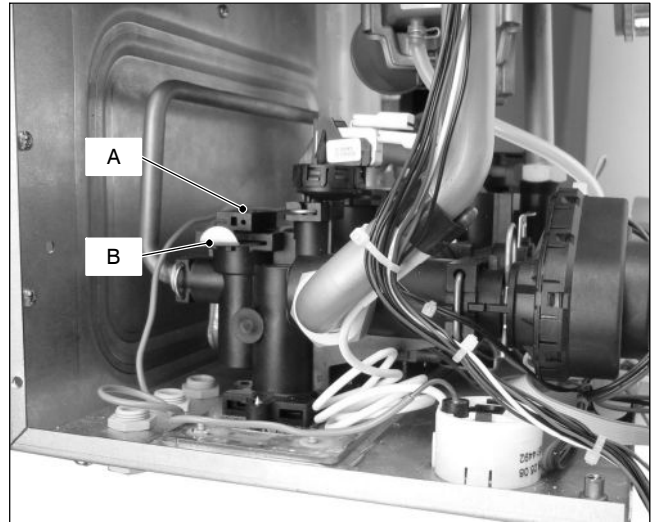

Fig. 16.2

- 4 Reassemble the by-pass valve as illustrated in Fig. 16.2 reversing the order of removal.

Warning: to lubricate the O-ring gaskets exclusively use a silicone base grease compatible to be in contact with foods and approved by the local water Authorities.

Attention. When reassembling the By-pass valve be sure that it is correctly oriented by matching the reference C with the notch D of the water group Fig. 16.3

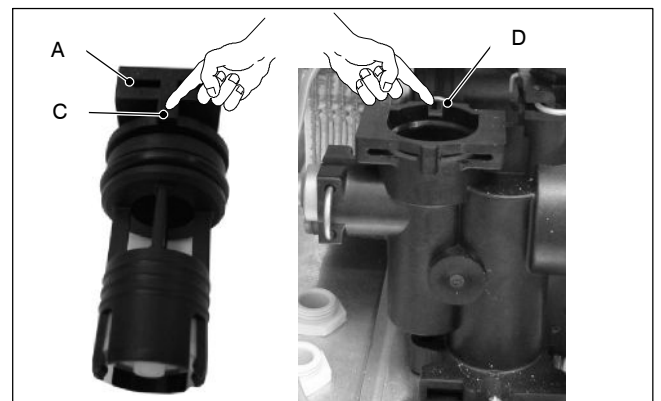

Fig. 16.3

17 Fan and Air box

17.1 Function

The function of the Fan *A* (Fig. 17.1) is to force the mixture of air and gas into the burner.

The function of the Air box *B* is to mix the gas and the air in the right proportion.

The flow rate of the air–gas mixture and consequently the input power of the boiler is proportional to the speed of the fan that is controlled by the electronic control p.c.b.

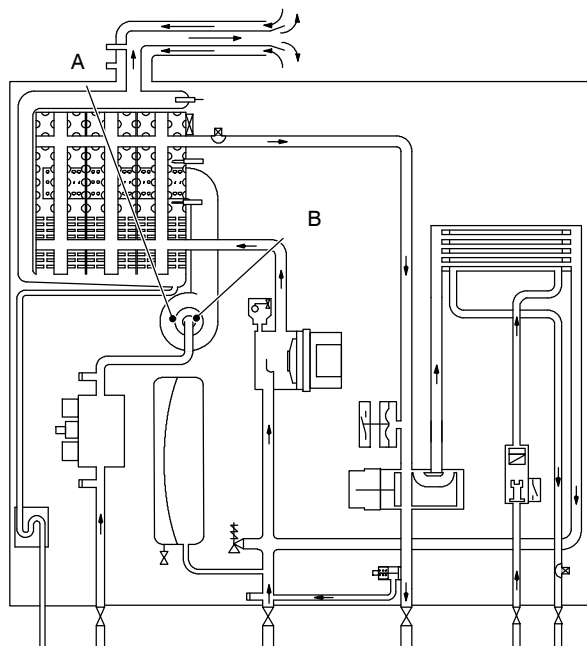

Fig. 17.1

17.2 Removal of the Fan and the Air box

Warning: isolate the boiler from the mains electricity supply before removing any covering or component.

- 1 Turn off the gas supply.
- 2 Remove all the case panels (see section 2).



Fig. 17.2

- 3 Disconnect the air manifold from pipe *C* by opening the strip (Fig. 17.2).

- 4 Disconnect the rubber pipe *D*.
- 5 Unscrew the gas connector *E*
- 6 Remove the fixing fork *F* and remove the gas pipe *G*.
- 7 Disconnect the connector *H*
- 8 Disconnect the fan connector *I* by pressing the plastic hook placed on the side of the connector.
- 9 Unscrew the screws *J*.
- 10 Remove the fan *A* with the air box *B*.
- 11 Remove the screws *K* and the air box *B* (Fig. 17.3).

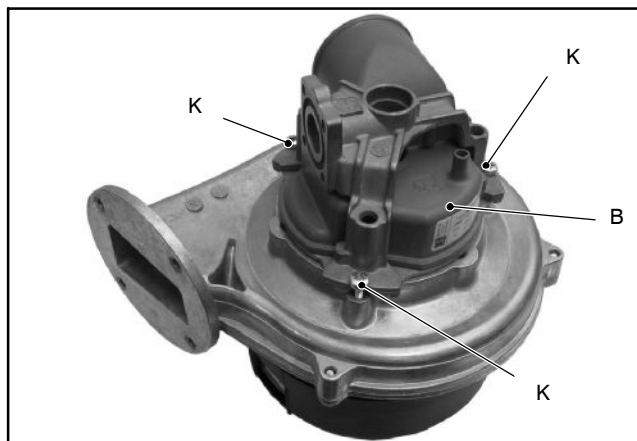

Fig. 17.3

- 12 Open the strip *L* by sliding the edges with the help of a screwdriver and remove the Air box (Fig. 17.4).

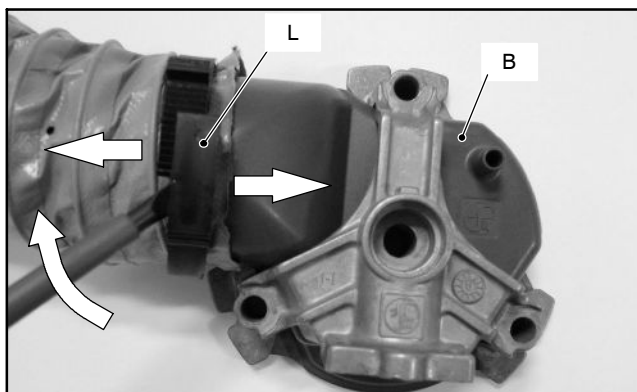

Fig. 17.4

- 13 Assemble the Fan and the Air box carrying out the removal operations in reverse sequence.

Before reassembling ensure the fan gasket (Fig. 17.2) is correctly mounted.

Warning: Be careful not to damage the OR gasket of the gas pipe when inserting the pipe in the air box (air/gas mixer).

After any service operation on the components of the gas circuit check all the connections for gas leaks.

Warning: After cleaning or replacement as detailed above, if it deemed necessary to undertake a combustion analysis, refer to the appropriate chapter *Maintenance* of the installation instructions manual.

18 Ignition and detection electrodes and burner

18.1 Function

Three electrodes are fitted on the fan–burner group. Two of them, fitted on the right side of the fan–burner group A, are the ignition electrodes B

On the left side is the detection electrode C and it detects the presence of the flame.

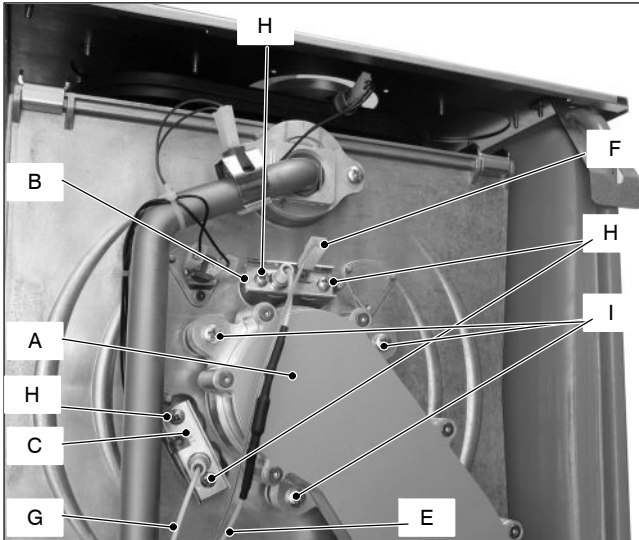

Fig. 18.1

The burner D is fitted on the rear of the fan–burner group A.

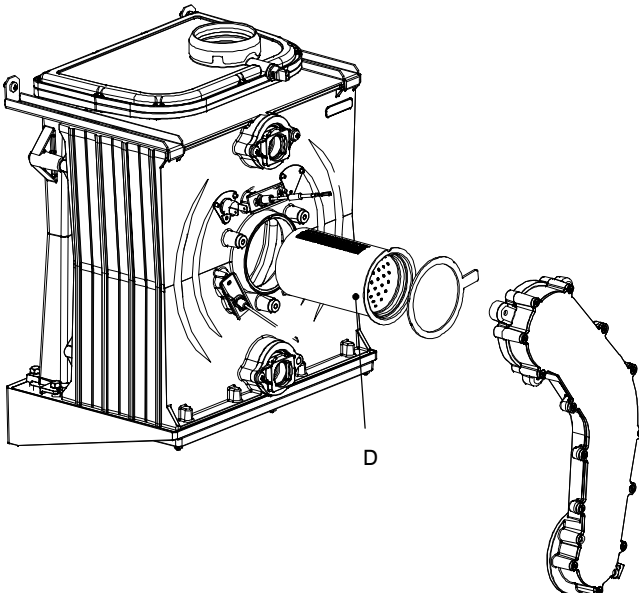

Fig. 18.2

18.2 Removal of the Ignition and detection electrodes

Warning: isolate the boiler from the mains electricity supply before removing any covering or component.

- 1 Remove all the case panels (see section 2) .

- 2 Disconnect the ignition electrodes connector E and the earth wire F (Fig. 18.1) and disconnect the detection electrode connector G.
- 3 Unscrew the screws H and remove the ignition electrodes B and the detection electrode C (Fig. 18.1).
- 4 Assemble the Ignition and detection electrodes carrying out the removal operation in reverse order.

18.3 Removal of the burner

Warning: isolate the boiler from the mains electricity supply before removing any covering or component.

- 1 Remove the air box and the fan (see section 17.2)
- 2 Unscrew the screws I (Fig. 18.1) and remove the fan–burner duct A.
- 3 Remove the burner by sliding it forward.

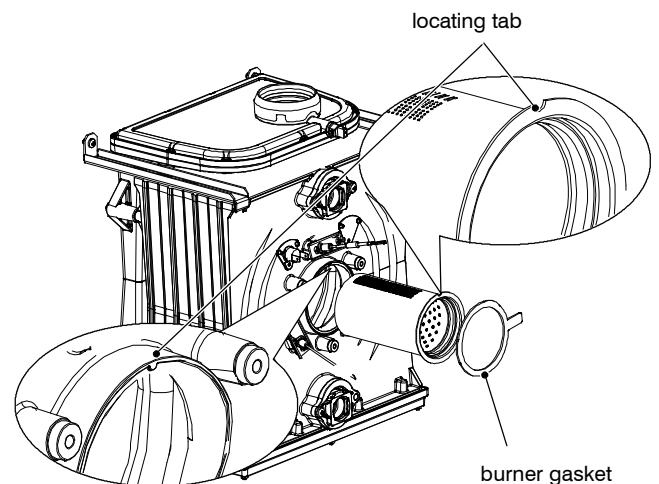

Fig. 18.3

- 4 Assemble the burner carrying out the removal operation in reverse order. Ensure the burner is correctly located by lining up the locating tab (Fig. 18.3).

Before reassembling ensure the burner gasket is correctly located.

Warning: After cleaning or replacement as detailed above, if it deemed necessary to undertake a combustion analysis, refer to the appropriate chapter *Maintenance* of the installation instructions manual.

18.4 Checks

- ✓ Check the position of the electrode edges
- Warning:** isolate the boiler from the mains electricity supply before removing any covering or component.
- 1 Remove the ignition electrodes (see section 18.2)
- 2 Check for the correct distance between the metallic edges of the ignition electrode (see Fig. 18.4).

Ignition and detection electrodes

✓ Check the connection wires.

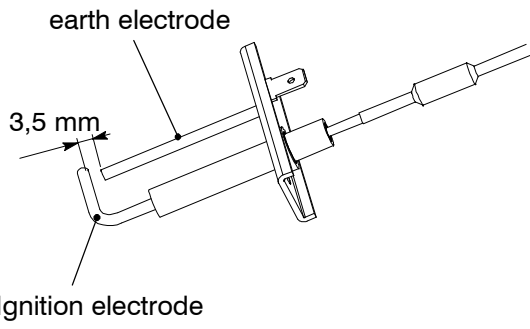

Fig. 18.4

19 Safety thermostat

19.1 Function

The safety thermostat *A* in Fig. 19.1 is a device that senses the temperature of the primary circuit water which flows in the outlet pipe of the condensing heat exchanger.

If the temperature control system of the boiler fails and the temperature of the primary circuit reaches a dangerous temperature, the safety thermostat opens the electric circuit that supplies the on – off operators of the gas valve.

Consequently, the full sequence ignition device attempts to light the burner and, at the end, locks the boiler and lights the lock – out signal lamp.

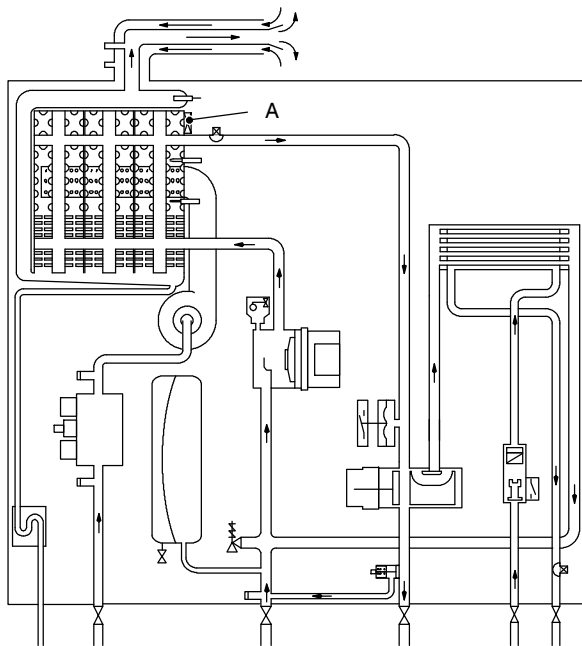

Fig. 19.1

19.2 Checks

- ✓ Overheat temperature value
- 1 Set the temperature control knobs to their max. position and run the boiler in d.h.w. and c.h.
- 2 Allow the boiler to reach its maximum operating temperature (monitor the temperature gauge on the instrument panel). The boiler should maintain a temperature below that of the safety thermostat and no overheat intervention should occur.

⚡ **Warning: isolate the boiler from the mains electricity supply before removing any covering or component.**

- ✓ Electrical function
- 1 Remove all the case panels and the lid of the sealed chamber.
- 2 Disconnect the safety thermostat and check its electrical function. Normally (no intervention) the contact must be closed (electrical resistance zero Ω).

19.3 Removal

⚡ **Warning: isolate the boiler from the mains electricity supply before removing any covering or component.**

- 1 Remove all the case panels and the lid of the sealed chamber.
- 2 Disconnect the wiring *B* (detail in Fig. 19.2).
- 3 Unscrew the screws *C* and remove the overheat thermostat.

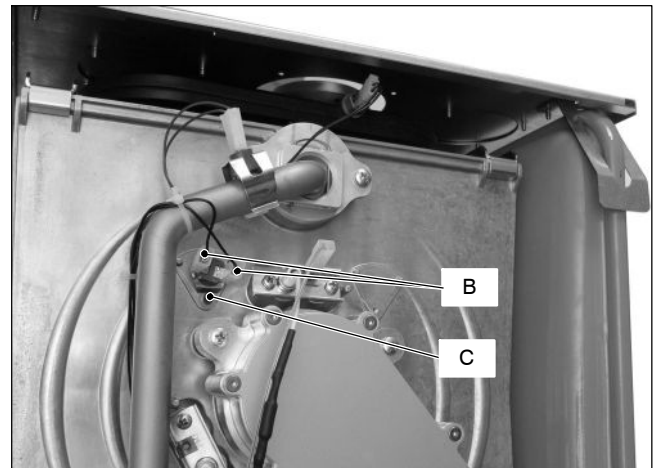

Fig. 19.2

- 4 Reassemble the overheat thermostat carrying out the operations in reverse order.
- 5 Apply an adequate quantity of heat conducting compound between the pipe and the thermostat.

⚠ **Warning: After cleaning or replacement as detailed above, if it deemed necessary to undertake a combustion analysis, refer to the appropriate chapter *Maintenance of the installation instructions manual*.**

20 Flue temperature probe NTC and Safety thermal fuse

20.1 Function

The Flue temperature probe NTC *A* in Fig. 20.1 and Fig. 20.2 senses the temperature of the combustion products that flow through the condensing heat exchanger.

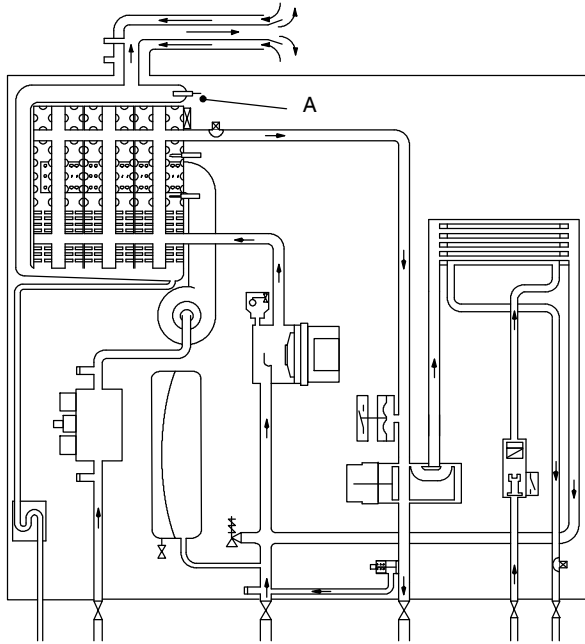

Fig. 20.1

If the temperature of the combustion products circuit reaches the limit temperature, the Flue temperature probe NTC reduces the gas flow rate to the burner. The temperature of the combustion products should decrease to a safe value temperature.

In the case that the temperature of the combustion products reaches a potentially dangerous value, it stops the boiler operation (lock-out).

This allows the use of plastic materials for the flue outlet pipes and bends.

The use of kits different from the original isn't however allowed, since the flue pipes are integral parts of the boiler.

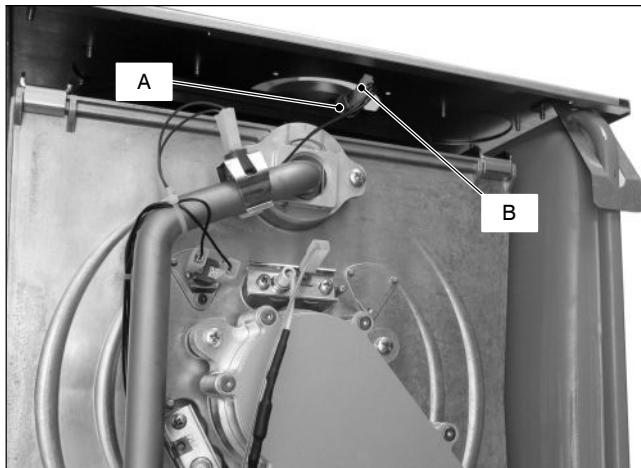

Fig. 20.2

20.2 Removal

Warning: isolate the boiler from the mains electricity supply before removing any covering or component.

- 1 Remove all the case panels.
- 2 Disconnect the connector *B* from the Flue temperature probe NTC by pressing the plastic hook placed on the side of the connector.
- 3 Unscrew and remove the flue temperature probe *A* (Fig. 20.2) from the condensing heat exchanger.
- 4 Assemble the Flue temperature probe NTC carrying out the removal operations in reverse sequence.

20.3 Checks

Overheat temperature value

- 1 Set the temperature control knobs to their max. position and run the boiler in d.h.w. and c.h.
- 2 Allow the boiler to reach its maximum operating temperature (monitor the temperature gauge on the instrument panel). The boiler should maintain a temperature below that of the Flue temperature probe NTC and no overheat intervention should occur.

Temperature-resistance relationship

- 1 Remove the Flue temperature probe NTC (see section 20.2).
- 2 Measure the Flue temperature probe NTC electrical resistance at the ambient temperature and check it according to the graph in Fig. 20.3

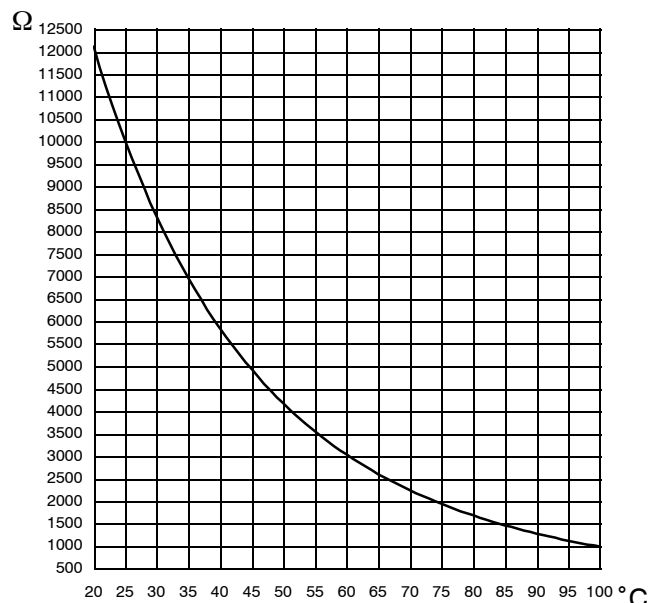

Fig. 20.3

21 Condensate trap

21.1 Function

The condensate trap *A* in Fig. 21.1 and Fig. 21.2 allows the discharge of the condensate via the condensate drain pipe avoiding in the mean time the escape of combustion products.

A plastic ball closes the trap outlet in case that the trap is empty.

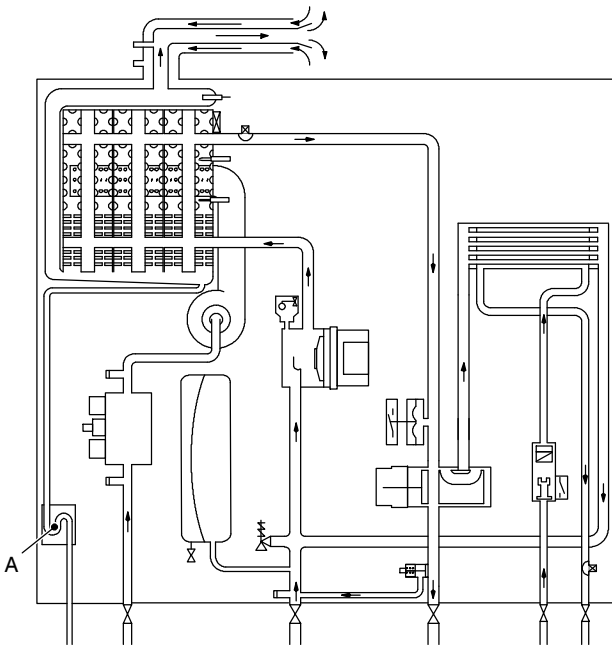

Fig. 21.1

If the drain pipe is plugged or in any case in which the condensate isn't correctly evacuated, the condensate level in the trap rises till it reaches a screw that is in contact with the flame detection circuit thus causing the boiler lock-out.

21.2 Check the cleanness of the trap

Unscrew the plug *B* on the bottom of the trap *A* and remove dirt eventually deposit (Fig. 21.2).

21.3 Removal

Warning: isolate the boiler from the mains electricity supply before removing any covering or component.

- 1 Remove the front and right case panels.
- 2 Unscrew the threaded locking ring *C* and remove the flexible pipe *D* (Fig. 21.2).
- 3 Disconnect the electric connector *E*
- 4 Using pliers, remove the spring *F* moving it upwards.
- 5 Remove the trap *A* from the pipe *G*.
- 6 Reassemble carrying out the removal operations in reverse order.

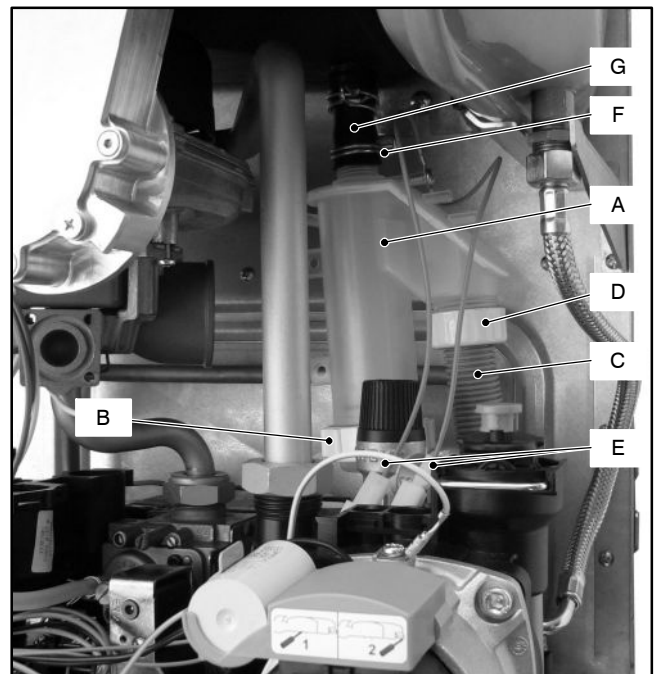
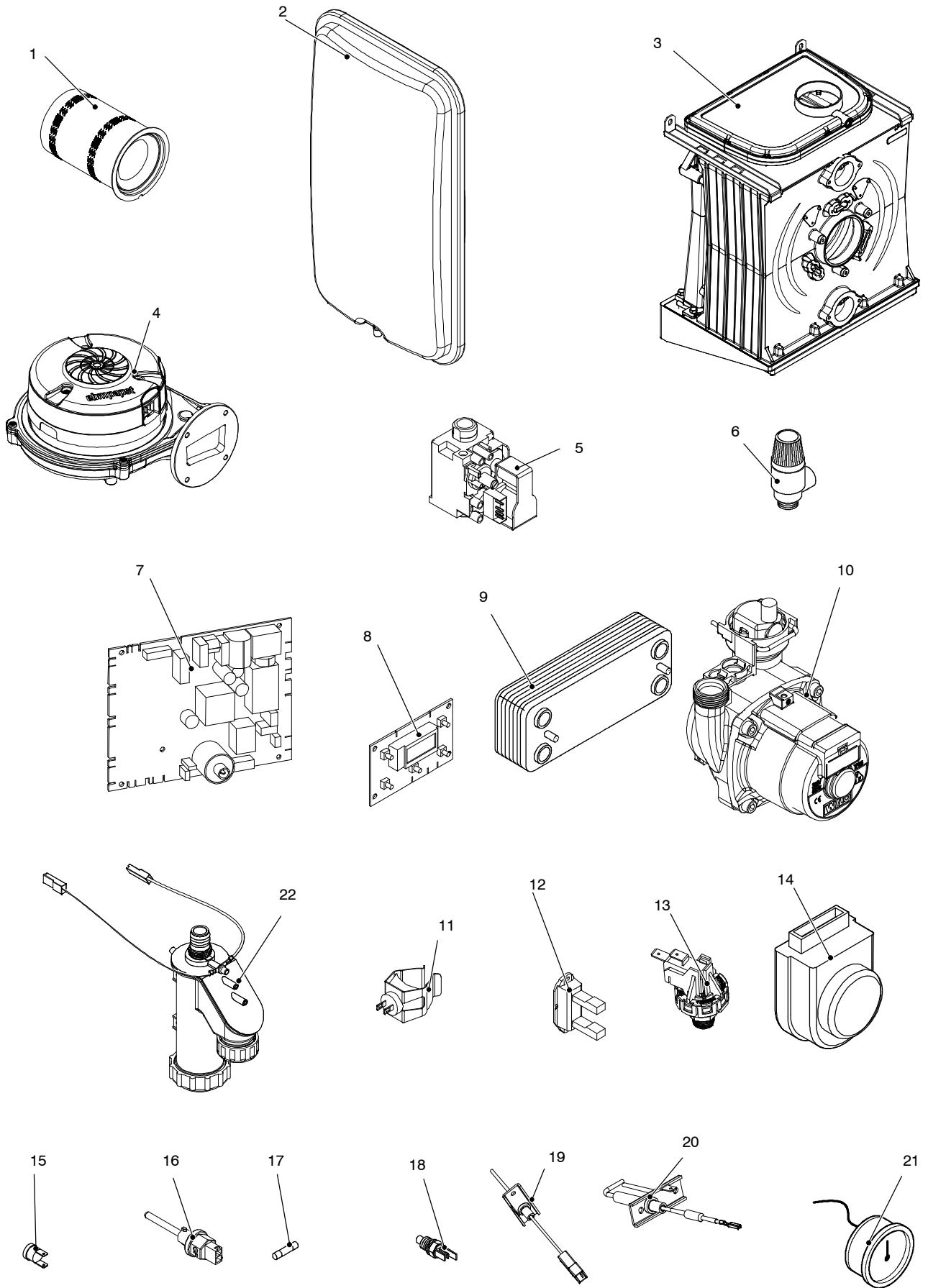

Fig. 21.2

22 Short spare parts list

Key	G.C. part no.	Description	Q.ty	Manufac- turer part no.	Manufacturer's reference
1		Burner (mod. Activ A 25C, Activ A 18S)	1	BI1313 100	
		Burner (mod. Activ A 30C., Activ A 35C., Activ A 25S, Activ A 30S)	1	BI1313 101	
2		Expansion vessel	1	BI1462 100	
3		Condensing heat exchanger (mod. Activ A 25C, Activ A 18S)	1	BI1462 101	
		Condensing heat exchanger (mod. Activ A 30C., Activ A 35C., Activ A 25S, Activ A 30S)	1	BI1462 102	
4		Fan	1	BI1313 102	
5		Gas valve	1	BI1313 103	SIT 848 Sigma 0848135
6	H50-189	Safety valve	1	BI1181 100	Watts
7		Main Electronic control/ignition p.c.b.	1	BI2035 100	
8		Control panel electronic p.c.b.	1	BI2035 101	
9	H22-543	D.h.w. heat exchanger (Activ A 25C)	1	BI1181 122	
	E01-204	D.h.w. heat exchanger (mod. Activ A 30C., Activ A 35C.)	1	BI1001 101	
10		Pump (mod. Activ A 25C, Activ A 30C., Activ A 35C.)	1	BI1462 103	
		Pump (mod. Activ A 18S, Activ A 25S, Activ A 30S)	1	BI1462 119	
11		Temperature probe (main circuit)	1	BI1442 106	
12	169-010	D.h.w. flow switch	1	KI1042 107	
13		Primary circuit pressure switch	1	BI1351 118	
14		Three way diverter valve (electric actuator)	1	BI1351 108	
15	E83-101	Overheat thermostat	1	BI1172 105	ELTH - type 261
16	H58-661	Flue temperature probe NTC	1	BI1432 102	
17	E23-792	Fuse 2 AF 250VAC 5x20	2	BI1165 112	
18		Temperature probe (D.h.w. circuit)	2	KI1042 501	
19		Detection electrode	1	BI1313 104	
20		Ignition electrode	1	BI1313 105	
21		Pressure gauge	1	BI1695 101	
22		Condensate trap	1	BI1462 104	





17962.1825.1 2909 48A4 UK

Biasi UK Ltd
Newman Park, Western Way
Wednesbury, WS10 7BJ
Sales Tel No: 0121 506 1340
Sales Fax No: 0121 506 1360
Service Tel No: 0121 506 1350
Service Fax No: 0121 506 1370
www.biasi.co.uk