

MAIN

Installation & Service Instructions

Main HE

Condensing
Central Heating Boiler

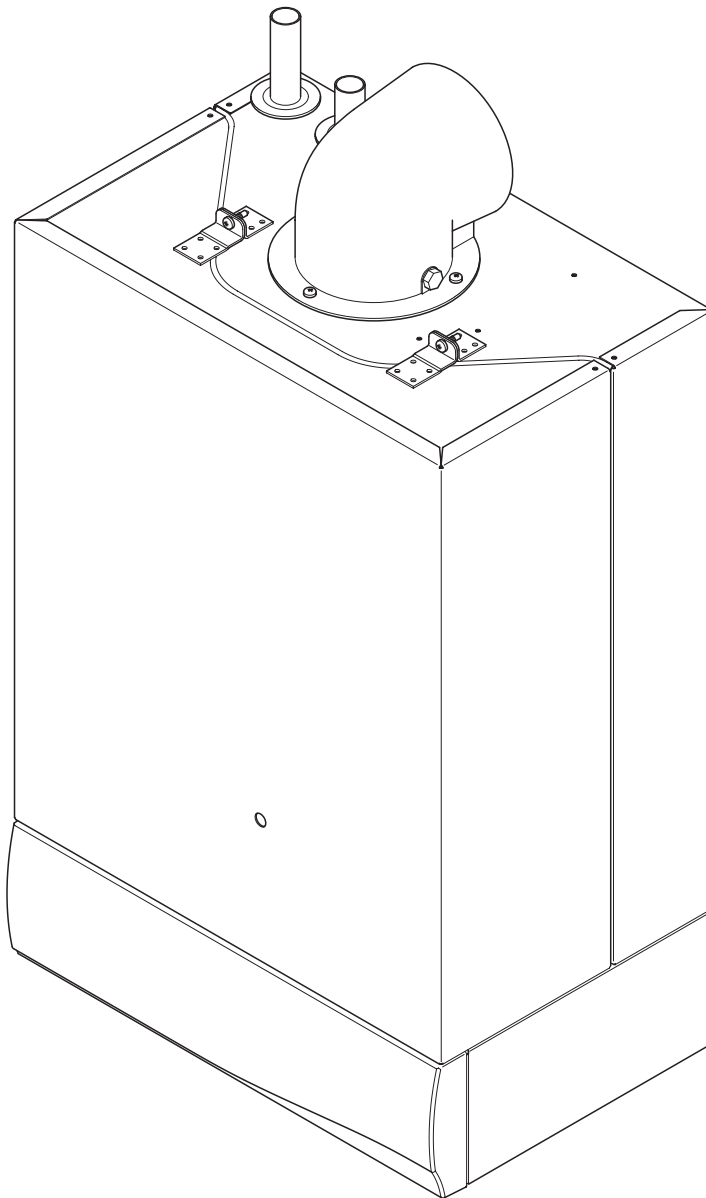

Only a flue approved for the Main HE can be used.

These instructions include the Benchmark Commissioning Checklist and should be left with the user for safe keeping.

Contents

1. Introduction.....	4
2. Technical Data.....	6
3. Installation Requirements.....	8
3.1 General Information.....	8
3.2 Legislation, Standards & Codes of Practice....	8
3.3 Gas Supply.....	8
3.4 Electricity Supply.....	9
3.5 Location of Boiler.....	9
3.6 Condensate Disposal.....	10
3.7 Air Supply.....	11
3.8 Flue Systems.....	11
3.9 Plume Displacement.....	18
3.10 Water Circulating Systems.....	22
4. Installation.....	26
4.1 Unpack, Prepare the Wall & Boiler.....	26
4.2 Install the Flue.....	27
4.3 Electrical Connections.....	28
4.4 Connect the Gas Supply.....	29
4.5 Connect the Water System.....	29
4.6 Connect the Condensate Drain.....	29
5. Wiring Diagrams.....	30
6. Commissioning.....	32
6.1 Commission the Systems.....	32
6.2 Commission the Boiler.....	32
6.3 Flush the System.....	32
6.4 Final Adjustments.....	33
6.5 Advise the User.....	33
6.6 Documentation.....	33
7. Control Sequence.....	34
8. Fault Finding Guides.....	35
9. Servicing & Parts Replacement.....	42
9.1 Servicing Procedure.....	42
9.2 General Access.....	44
9.3 PCB Enclosure.....	44
9.4 Gas Valve.....	44
9.5 Air Pressure Switch.....	45
9.6 Spark Igniter.....	45
9.7 Flow/Casting Sensors.....	45
9.8 Overheat Sensor.....	45
9.9 Fan & Flue Hood.....	46
9.10 Electrodes/Burner.....	47
9.11 Injector.....	47
9.12 Combustion Chamber Insulation.....	48
9.13 Condensate Trap.....	49
9.14 Primary Heat Exchanger.....	50
9.15 Secondary Heat Exchanger.....	51
10. Short Spares List.....	52
Benchmark Commissioning Checklist	54

Building Regulations and the Benchmark Commissioning Checklist

Building Regulations (England & Wales) require notification of the installation of a heating appliance to the relevant Local Authority Building Control Department. From 1 April 2005 this can be achieved via a Competent Persons Self Certification Scheme as an option to notifying the Local Authority directly. Similar arrangements will follow for Scotland and will apply in Northern Ireland from 1 January 2006.

The Health & Safety Executive operates the 'Gas Safe Register', a self-certification scheme for gas heating appliances.

These arrangements represent a change from the situation whereby compliance with Building Regulations was accepted as being demonstrated by completion of the Benchmark Logbook (which was then left on site with the customer).

With the introduction of Self Certification Schemes, the Benchmark Logbook is being withdrawn. However, a similar document in the form of a commissioning checklist and service interval record is incorporated at the back of these instructions.

This company is a member of the Benchmark initiative and fully supports the aims of the programme. Its aim is to improve the standards of installation and commissioning of central heating systems in the UK and to encourage the regular servicing of all central heating systems to ensure safety and efficiency.

Building Regulations require that installations should comply with manufacturer's instructions. It is therefore important that the commissioning checklist is completed by the installer. The relevant section of Building Regulations only relates to dwellings. Therefore the checklist only applies if the appliance is being installed in a dwelling or some related structure.

The flowchart opposite gives guidance for installers on the process necessary to ensure compliance with Building Regulations.



ISO 9001
FM 00866

Installer Notification Guidelines

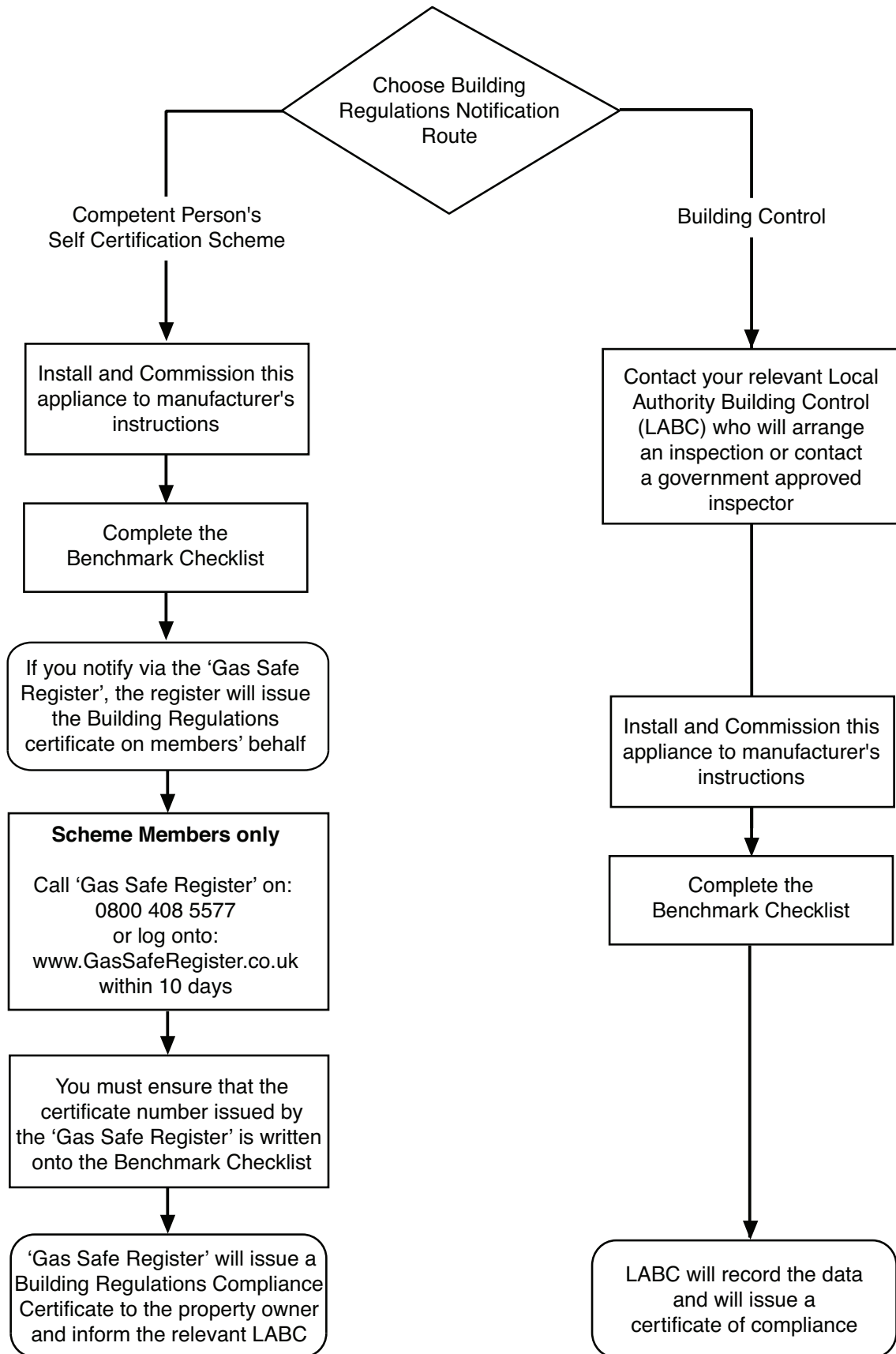

1. Introduction

Important Installation Notes

The boiler is suitable for use with fully pumped open vented and sealed systems with an indirect coil type high efficiency cylinder.

The gas type, supply size and pressure must be checked for suitability before connection.

Failure to install the condensate discharge pipework correctly could affect the reliable operation of the boiler.

For the boiler to operate correctly all air must be vented from the system prior to commissioning and the system itself must be suitably vented.

The system must be designed to always provide a route for water to circulate between the boiler flow and return.

For optimum boiler performance, pump performance must meet the requirements shown on Page 23.

Failure to flush and add inhibitor to the system may invalidate the boiler warranty.

Failure to commission the boiler correctly may result in the installer being charged for any visits made by Potterton.

The Benchmark Scheme

Benchmark places responsibilities on both manufacturers and installers. The purpose is to ensure that customers are provided with the correct equipment for their needs, that it is installed, commissioned and serviced in accordance with the manufacturer's instructions by competent persons and that it meets the requirements of the appropriate Building Regulations. The Benchmark Checklist can be used to demonstrate compliance with Building Regulations and should be provided to the customer for future reference.

Installers are required to carry out installation, commissioning and servicing work in accordance with the Benchmark Code of Practice which is available from the Heating and Hotwater Industry Council who manage and promote the Scheme. Visit www.centralheating.co.uk for more information.

© Baxi Heating UK Ltd 2009 All rights reserved. No part of this publication may be reproduced or transmitted in any form or by any means, or stored in any retrieval system of any nature (including in any database), in each case whether electronic, mechanical, recording or otherwise, without the prior written permission of the copyright owner, except for permitted fair dealing under Copyrights, Designs and Patents Act 1988.

Applications for the copyright owner's permission to reproduce or make other use of any part of this publication should be made, giving details of the proposed use, to the following address:

The Company Secretary, Baxi Heating UK Ltd, The Wyvern Business Park, Stanier Way, Derby, DE21 6BF.

Full acknowledgement of author and source must be given.

WARNING: Any person who does any unauthorised act in relation to a copyright work may be liable to criminal prosecution and civil claims for damages.

Potterton Main HE

Main 9 HE G.C. No. 41 474 01
Main 12 HE G.C. No. 41 474 02
Main 15 HE G.C. No. 41 474 03
Main 18 HE G.C. No. 41 474 04
Main 24 HE G.C. No. 41 474 05

Main HE boilers are fully automatically controlled, wall mounted, fan powered, balanced flue condensing boilers using a cast iron primary heat exchanger.

Main HE boilers meet the requirements of Statutory Instrument "The Boiler (Efficiency) Regulations 1993 No 3083" and deemed to meet the requirements of Directive 92/42/EEC on the energy efficiency requirements for new hot water boilers fired with liquid or gaseous fuels:-

Type test for purpose of Regulation 5 certified by:
Notified Body 0087.

Product/Production certified by:
Notified Body 0086.

For use with Natural Gas (G20) only at 20mbar and for use in GB/IE only.

Gas Safe

All Gas Safe registered engineers carry a ID card with their licence number and a photograph. You can check your engineer is registered by telephoning 0800 408 5500 or online at www.GasSafeRegister.co.uk

Identification

To gain access to the identification labels, pull the door down.

The data label is on a swing out plate located just above the operating lights and temperature control knob.

A seven digit version of the serial number is located on the operating label attached to the rear of the door.

Health and Safety Information for the Installer and Service Engineer

Under the Consumer Protection Act 1987 and Section 6 of the Health and Safety at Work Act 1974, we are required to provide information on substances hazardous to health.

Small quantities of adhesives and sealants used in the product are cured and present no known hazards. The following substances are also present.

Man-Made Mineral Fibre

- a) Some component parts of this boiler (insulation pads, gaskets and rope seals) are manufactured from man-made mineral fibre.
- b) Prolonged or excessive exposure to this material may result in some irritation to the eyes, skin or respiratory tract.
- c) It is advisable to wear gloves when handling these items.
- d) Irritant dust will only be released from the items if they are broken up or subjected to severe abrasion. In these instances a suitable dust mask and goggles should be worn.
- e) Always thoroughly wash hands after installation, servicing or changing components.
- f) When disposing of any items manufactured from man-made mineral fibre care must be exercised.
- g) If any irritation of the eyes or severe irritation of the skin is experienced seek medical attention.

2. Technical Data

Models		9 HE	12 HE	15 HE	18 HE	24 HE
Heat Input - Gross	kW	10.22	13.62	17.04	20.43	27.25
	Btu/h	34,877	46,465	58,129	69,717	92,968
Heat Output (Non Condensing)	kW	8.82	11.78	14.76	17.72	23.63
	Btu/h	30,093	40,181	50,350	60,466	80,641
Heat Output (Condensing)	kW	9.50	12.64	15.66	18.83	24.94
	Btu/h	32,430	43,111	53,431	64,232	85,105
Gas Rate	m ³ /h	0.98	1.30	1.63	1.95	2.60
	ft ³ /h	34.5	45.9	57.5	68.9	91.9
Burner Pressure - Hot	mbar	8.6	10.4	9.0	8.4	12.8
	in wg	3.44	4.16	3.6	3.36	5.12
Gas Supply Pressure	mbar	20	20	20	20	20
Injector Size	mm	2.8	3.1	3.5	3.9	4.1
Water Content	litres	2.3 - 9, 12 & 15			2.7 - 18 & 24	
Boiler Weight (Lift/Installed - Dry)	kg	39.0 - 9, 12 & 15			42.8 - 18 & 24	
Nox Class		2	2	2	2	2
Maximum Working Head		30.5m (100 ft)				
Minimum Working Head		150mm (6 in)				
Flow Temperature Range		63°C - 82°C				
Gas Supply Connection		15 mm Tail				
Flow/Return Connections		22 mm Copper				
Condensate System Connection		21.5 mm PP				
Electricity Supply		230v ~ 50Hz				
External Fuse		3A				
Internal Fuse		Type 3.15AT				
Power Consumption		80 Watts (excluding pump)				
Electrical Protection		IP20				
Boiler Type		C12, C32, C52				
Boiler Category		CAT 1 ₂ H 2H - G20 - 20 mbar				

Model	Seasonal Efficiency (SEDBUK) (%)	SEDBUK Declaration for Main HE This value is used in the UK Government's Standard Assessment Procedure (SAP) for energy rating of dwellings. The test data from which it has been calculated have been certified by 0087.
9	86.1	
12	86.4	
15	86.2	
18	86.2	
24	86.2	

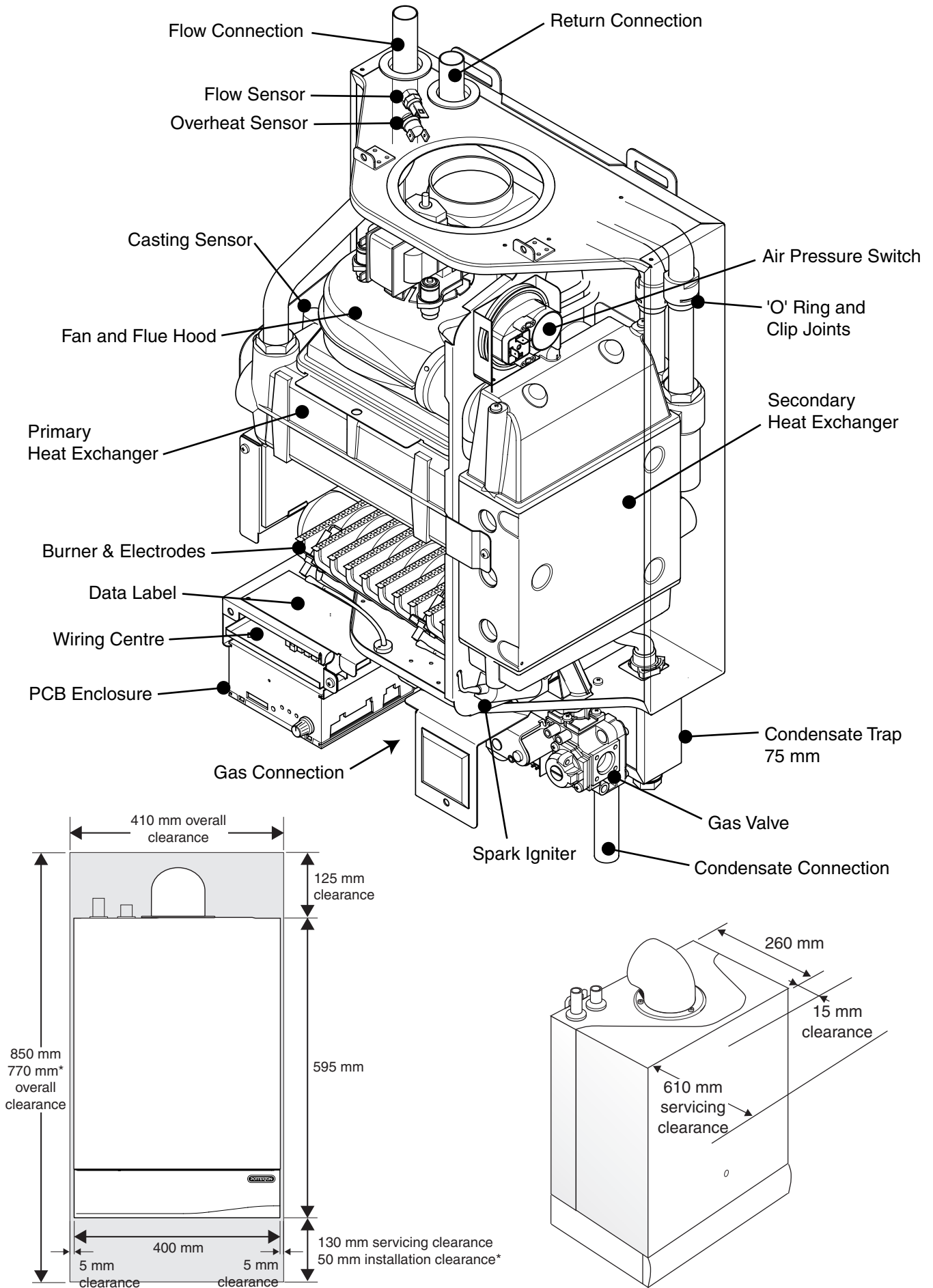

Fig. 1

3. Installation Requirements

3.1 General Information

Optional Extras

Various flue extensions, bends, vertical flue kits, control accessories etc. are available as optional extras. These are detailed in a separate publication.

Lifting

Important - This product should be lifted and handled by two people. Stooping should be avoided, and protective equipment worn when necessary. Carrying and lifting equipment should be used as required, for example when installing in a loft space.

3.2 Legislation, Standards & Codes of Practice

The boiler is suitable only for installation in GB and IE and **must be installed in accordance with the manufacturer's instructions and the rules in force, and only used in a suitably ventilated location.**

Any purpose provided ventilation should be checked periodically to ensure that it is free from obstruction.

Installation, Commissioning, Service & Repair

In GB, the installation must be carried out by a Competent Person. It must be carried out in accordance with the relevant requirements and current edition of:

The **GAS SAFETY (Installation and Use) REGULATIONS.**

The appropriate **BUILDING REGULATIONS** either the Building Regulations, The Building Regulations (Scotland), Building Regulations (Northern Ireland).

The **WATER FITTINGS REGULATIONS OR WATER BYELAWS** in Scotland.

The **I.E.E. WIRING REGULATIONS.**

Where no specific instructions are given, reference should be made to the relevant **BRITISH STANDARD CODES OF PRACTICE.**

Reference should also be made to **BRITISH GAS GUIDANCE NOTES FOR THE INSTALLATION OF DOMESTIC GAS CONDENSING BOILERS.**

Definition of competence: A person who works for a Gas Safe registered company and holding current certificates in the relevant ACS modules is deemed competent.

Important – Failure to install and commission this boiler to manufacturer's instructions may invalidate the warranty. This does not affect your statutory rights. In IE, the installation must be carried out by a competent person and installed in accordance with the current edition of:

I.S.813 "DOMESTIC GAS INSTALLATIONS".

The current **BUILDING REGULATIONS.**

Reference should also be made to the **ETCI** rules for electrical installation.

In GB the following Codes of Practice apply:

STANDARD	SCOPE
B.S. 6891	Gas Installation.
B.S. 5440: Pt 1	Flues.
B.S. 5440: Pt 2	Air Supply.
B.S. 5546	Installation of hot water supplies for domestic purposes.
B.S. 7074	Expansion vessels and ancillary equipment for sealed water systems.
B.S. 5449	Forced circulation hot water systems.
B.S. 6798	Installation of gas fired hot water boilers.
B.S. 7593	Treatment of water in domestic hot water central heating systems.
B.S. 7671	IEE Wiring Regulations

In IE:

STANDARD	SCOPE
I.S. 813	Domestic Gas Installations.
The following BS standards give valuable additional information	
B.S. 5546	Installation of hot water supplies for domestic purposes.
B.S. 7074	Expansion vessels and ancillary equipment for sealed water systems.
B.S. 5449	Forced circulation hot water systems.
B.S. 7593	Treatment of water in domestic hot water central heating systems.

3.3 Gas Supply

The meter and supply pipes must be capable of delivering the required quantity of gas in addition to the demand from any other appliances in the house and must be governed at the meter.

The pipe diameter required will depend on the boiler model and the pipe length from the gas meter.

The gas installation should be in accordance with BS6891.

3.4 Electricity Supply

230V ~ 50Hz via a fused double pole switch with a contact separation of at least 3 mm in both poles.

There must be only one common isolator for the boiler and its control system, it must provide complete electrical isolation and be fitted adjacent to the boiler.

There is no method of isolating the boiler at the user interface.

The power cable to the boiler must be 4-core to supply permanent live, neutral, earth and switched live.

Electrical installation should be in accordance with BS7671.

WARNING: THIS BOILER MUST BE EARTHED AND CORRECTLY POLARISED.

3.5 Location of Boiler

The boiler must be mounted on a flat wall which is sufficiently robust to take the weight of the boiler.

Location

The boiler should be fitted within the building unless otherwise protected by a suitable enclosure.

Clearances

The boiler requires only the clearances shown on Page 7, after installation.

Combustible Wall

The boiler is suitable for installation to a combustible wall e.g. wood cladding, provided that the flue duct is not closer than 25 mm to combustible material. A metal sleeve should be installed to surround the flue duct to provide a 25 mm annular space. Further guidance is given in BS5440: Pt 1.

Timber Frame

If the boiler is to be fitted into a building of timber frame construction then reference must be made to the current edition of Institution of Gas Engineers Publication IGE/UP/7/ (Gas Installation in Timber Framed Housing).

Bath or Shower Room

If the boiler is fitted in a room containing a bath or shower, it cannot be fitted in zone 0, 1 or 2 (Figs. A & B shows zone dimensions for a bathtub. For other examples refer to the Current I.E.E. Wiring Regulations) reference must be made to the relevant requirements.

In GB this is the current I.E.E. Wiring Regulations and Building Regulations.

In IE reference should be made to the current edition of I.S. 813 "Domestic Gas Installations" and the current ETCI rules.

Cupboard or Compartment

A cupboard or compartment used to enclose the boiler must be designed and constructed specifically for this purpose. An existing cupboard or compartment may be used provided that it is modified for the purpose. Details of essential features of cupboard/compartment design including airing cupboard installations are given in BS6798 and BS5546.

Service Access

Pipes and wiring must not restrict service access to the boiler

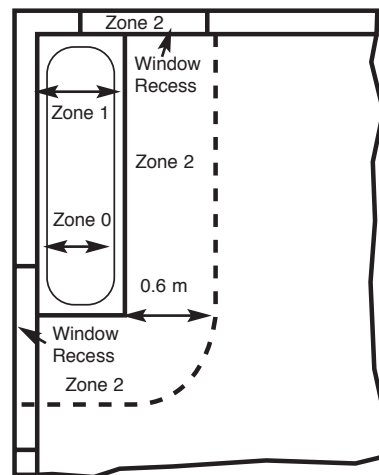

Fig. A In GB Only

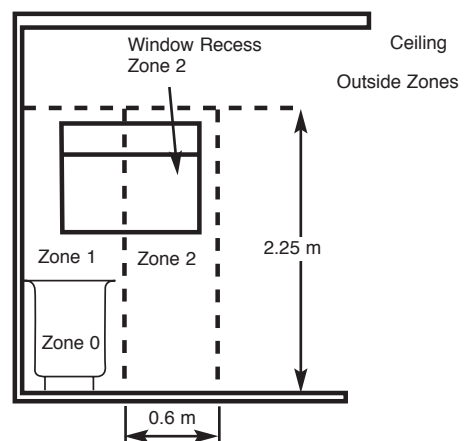

Fig. B In GB Only

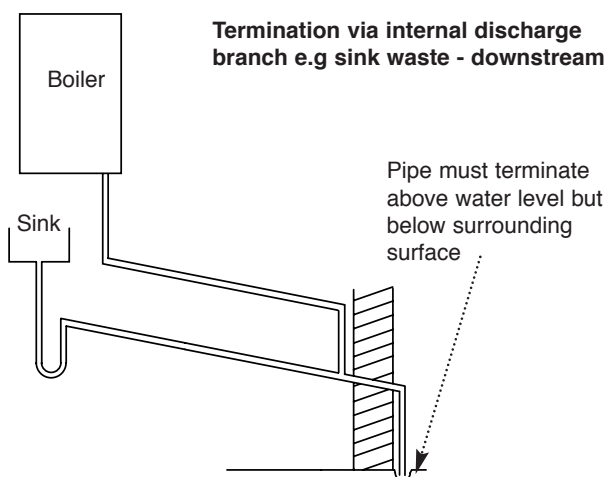

Fig. 4

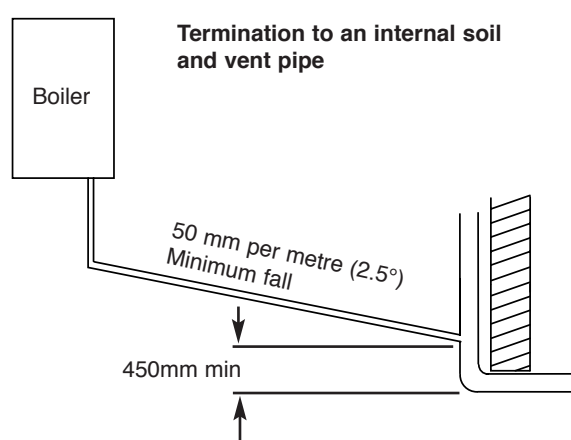

Fig. 5

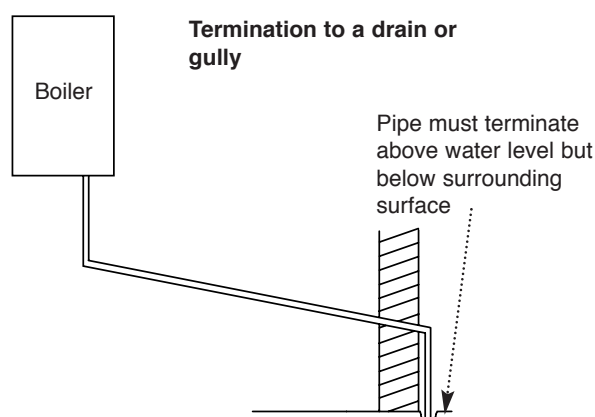

Fig. 6

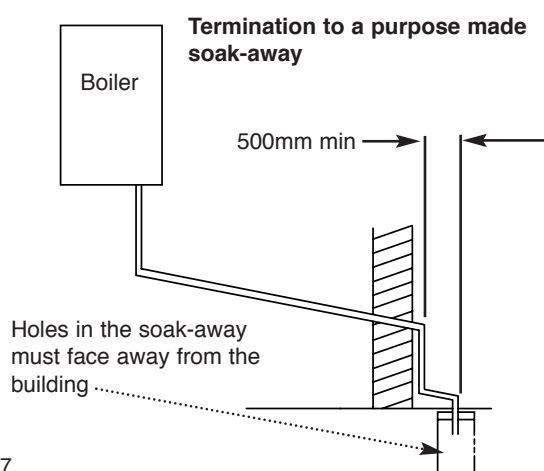

Fig. 7

3.6 Condensate Disposal

This boiler incorporates a 75 mm trap.

Ensure the disposal of condensate complies with any national or local regulations in force.

Failure to install the condensate disposal pipework correctly will affect the reliable operation of the boiler.

The pipe must always slope continually downward away from the boiler by at least 50 mm in every metre (approx. 2.5°). No air breaks are required in the pipe.

1. The pipe should be run in a proprietary drain pipe material e.g. PVC, PVC-U, ABS, PVC-C or PP. Metal pipework is NOT suitable for use in condensate disposal systems.
2. The pipe should be a minimum of 21.5 mm diameter and must be supported using suitably spaced clips to prevent sagging.
3. To reduce the risk of condensate being trapped, as few bends and fittings as possible should be used.
4. When disposing condensate into a soil stack or waste pipe the effects of existing plumbing must be considered. If soil pipes or waste pipes are subjected to internal pressure fluctuations when WC's are flushed or sinks emptied then back-pressure may force water out of the boiler trap and could affect the operation of the boiler.
5. Any condensate pipework external to the building (or in an unheated part of it e.g. garage) should not exceed 3 metres in length and when in an exposed position, waterproof insulation is recommended. It is also recommended that the pipe diameter is increased to 32 mm.

If the boiler is fitted in an unheated location the entire condensate pipe should be treated as an external run.

Examples are shown of the following methods of termination in order of preference:-

- i) via an internal discharge branch (e.g. sink waste) - Fig. 4.
- ii) to an internal soil & vent pipe - Fig. 5.
- iii) to a drain or gully - Fig. 6.
- iv) to a purpose made soakaway - Fig. 7.

BS 6798 & Part H1 of the Building Regulations give further guidance.

3.7 Air Supply

The room in which the boiler is installed does not require a purpose provided air vent.

3.7.1 Ventilated Cupboard/Compartment

If the boiler is installed in a cupboard or compartment (with the exception of those installations covered by Section 3.7.2), permanent air vents are required in the cupboard or compartment, one at high level and one at low level, either direct to the outside air or to a room. Both high level and low level air vents must communicate with the same room or must be on the same wall to outside air. Both the high level and low level vent to a room must each have a free area as stated below. The free area of each vent may be halved if the ventilation is provided directly from outside.

Models: 9 HE: 92 cm ²	18 HE: 184 cm ²
12 HE: 123 cm ²	24 HE: 246 cm ²
15 HE: 154 cm ²	

The minimum size of ventilated compartment is 850 mm high by 410 mm wide. If the cupboard or compartment has a door the depth must be a minimum of 275 mm. This will allow for a minimum of 15 mm clearance between the front of the boiler and the door for air movement.

3.7.2 Unventilated Compartment

The 9, 12 and 15 models can be installed in an unventilated compartment providing the following conditions are met and no other heat sources are present within the compartment:

1. Minimum sizes for alternative compartments that include the required clearances are shown in Table 1.

Unventilated Compartments

Example 1		Example 2	
Height	1295 mm	Height	990 mm
Width	550 mm	Width	750 mm
Depth	540 mm	Depth	750 mm
Minimum clearances within compartment			
Top	450 mm	Top	265 mm
Bottom	250 mm	Bottom	130 mm
Side	75 mm	Side	175 mm
Front	280 mm	Front	490 mm

Table 1

2. Maximum Horizontal flue length from turret for boiler in unventilated compartment is 560 mm.

Ventilation should be in accordance with BS 5440: Pt 2.

3.8 Flue Systems

Horizontal

The standard flue/terminal assembly can be cut and is suitable for an installed length from 160 mm up to 700 mm.

1 m flue extensions are available. Maximum straight flue length 3.55 m (3 extensions) (equivalent resistance = 3.55 m). It is recommended that the flue is supported at least once per metre.

All lengths quoted exclude the boiler elbow.

Example layouts are shown on the Page 13.

Bends

A 93° bend is equivalent to a 1m length of flue.

A 135° bend is equivalent to a 0.5m length of flue.

Vertical

For information on vertical flues consult the instructions supplied with the vertical flue kits.

3.8.1 Flue Terminal Location

The following guidelines indicate the general requirements for siting balanced flue terminals.

- With a condensing boiler a plume of water vapour will be discharged from the flue. This should be taken into account when siting the flue and the effect it could have on neighbouring property and occupants.
- If a terminal is less than 2 metres above a balcony, above ground, or above a flat roof to which people have access a suitable terminal guard must be fitted centrally about the terminal.
- If the terminal discharges onto a pathway or passageway, check that the combustion products will not cause a nuisance and that the terminal will not obstruct the passageway.
- For fitting under low soffits, eaves and to extend beyond guttering it is acceptable for the flue to project up to 500 mm from the face of the wall to the inside of the air intake. This can be painted if required using a suitable external paint.

The terminal location should be in accordance with, in GB, BS 5440 Pt. 1. and IE, I.S. 813 "Domestic Gas Installations".

Terminal Position with Minimum Distance (Fig. 8) (mm)

A ^a	Directly below an opening, air brick, opening windows, etc	300
B ^a	Above an opening, air brick, opening window etc.	300
C ^a	Horizontally to an opening, air brick, opening window etc.	300
D	Below gutters, soil pipes or drain pipes.	25
E	Below eaves.	25
F	Below balconies or car port roof.	25
G	From a vertical drain pipe or soil pipe.	25
H	From an internal or external corner.	25
I	Above ground, roof or balcony level.	300
J	From a surface or boundary line facing a terminal.	600
K	From a terminal facing a terminal (Horizontal flue).	1200
	From a terminal facing a terminal (Vertical flue).	600
L	From an opening in carport (e.g. door, window) into the dwelling.	1200
M	Vertically from a terminal on the same wall.	1500
N	Horizontally from a terminal on the same wall.	300
R	From adjacent wall to flue (vertical only).	300
S	From an adjacent opening window (vertical only).	1000
T	Adjacent to windows or openings on pitched and flat roofs	600
U	Below windows or openings on pitched roofs	2000

^a In addition, the terminal should be no nearer than 150 mm to an opening in the building fabric formed for the purpose of accommodating a built-in element such as a window frame. See BS 5440 Pt. 1.

IMPORTANT:

- Only **ONE** 25mm clearance is allowed per installation.
- Under car ports we recommend the use of the plume displacement kit.
- The terminal position must ensure the safe and nuisance-free dispersal of combustion products.

NOTE: The distance from a fanned draught appliance terminal installed parallel to a boundary may not be less than 300mm in accordance with the diagram below

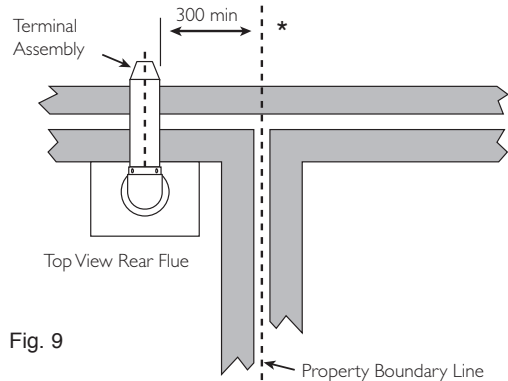

Fig. 9

IMPORTANT: If fitting a Plume Displacement Flue Kit, the air inlet must be a minimum of 100mm from any opening windows or doors (see Plume Displacement Section 3.9).

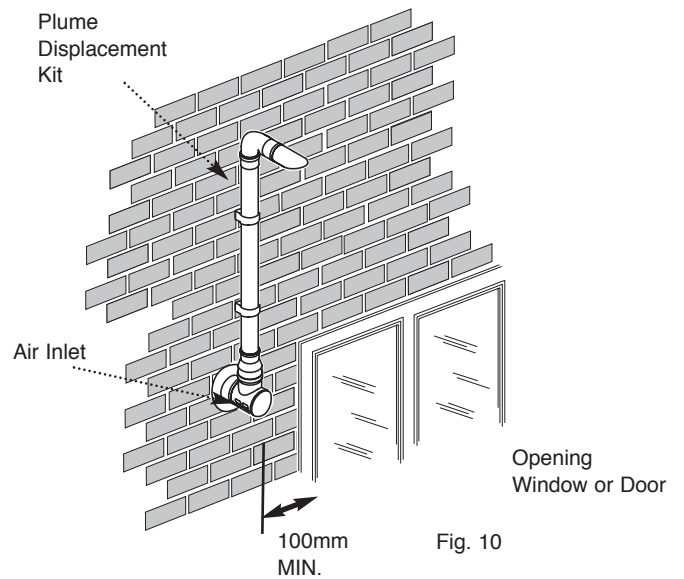

Fig. 10

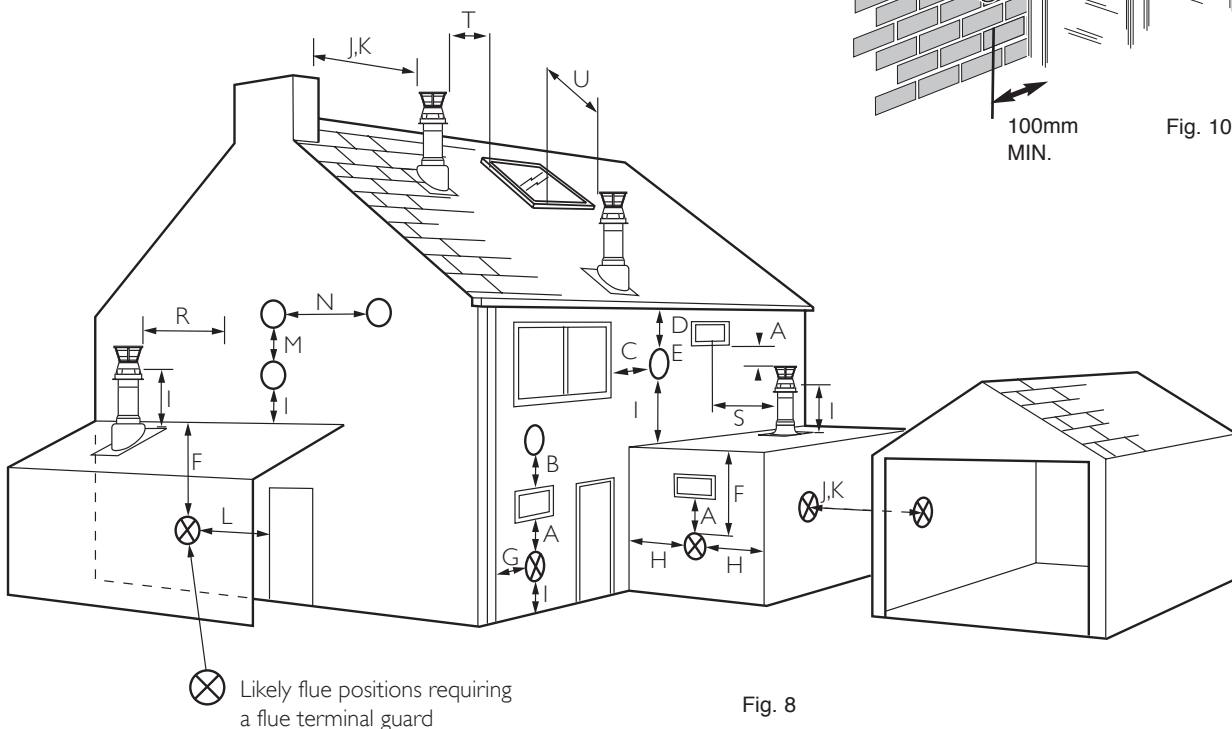
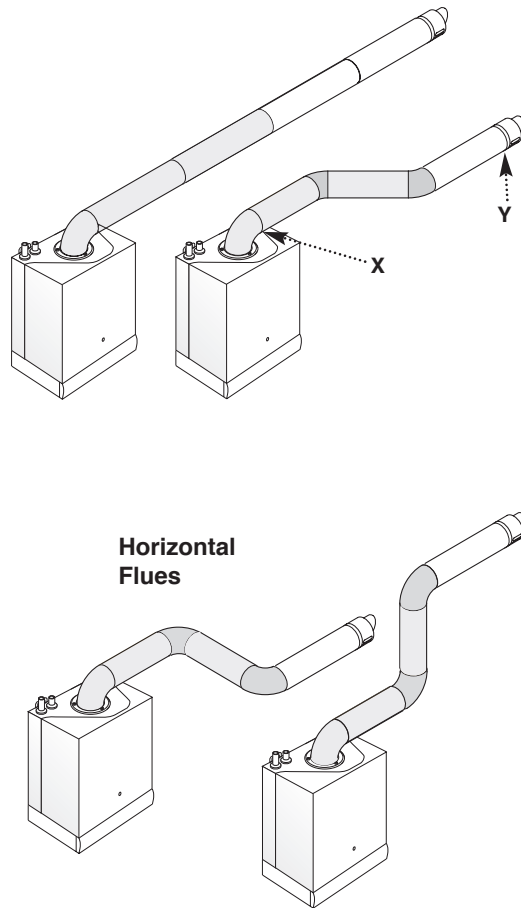
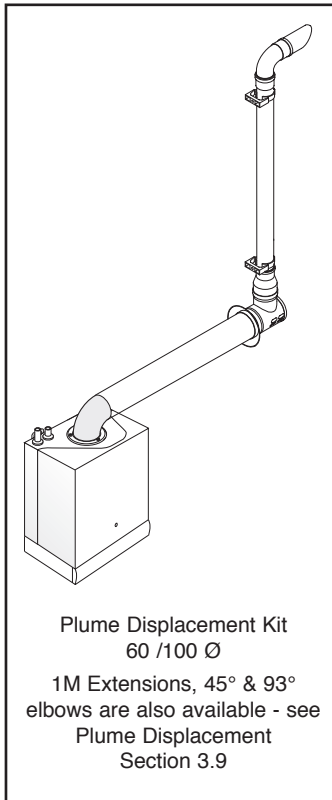

Fig. 8



3.8.2 Horizontal Flue Systems

1. The standard flue is suitable only for horizontal applications.
2. Maximum permissible equivalent flue lengths is:-

Horizontal Concentric 3.55m

3. Any additional "in line" bends in the flue system must be taken into consideration. Their equivalent lengths are:-

Concentric Pipes:

135° bend 0.5 metres

93° bend 1.0 metres

Twin Flue Pipe

135° bend 0.25 metres

91.5° bend 0.50 metres

The elbow supplied with the standard horizontal flue is not included in any equivalent length calculations.

NOTE: Flue length is measured from point X to Y as shown.

Important: All flue systems must be securely supported at least once every metre. Suitable pipe supports are available as accessories.

NOTE: Horizontal flue pipes should always be installed with at least a 1.5° fall from the terminal to allow condensate to run back to the boiler.

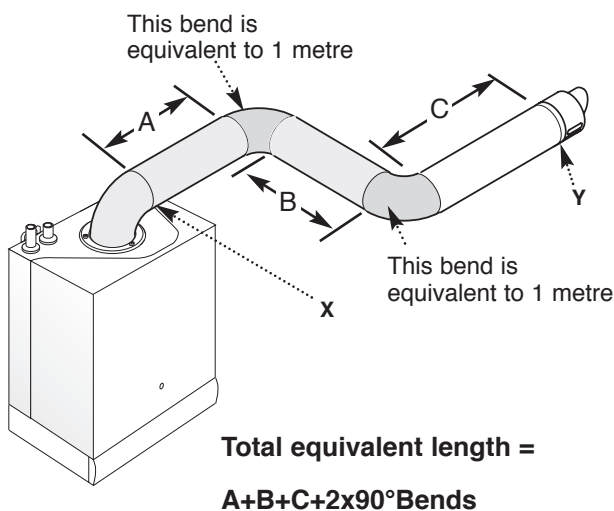

Vertical Flues (Twin Pipe)

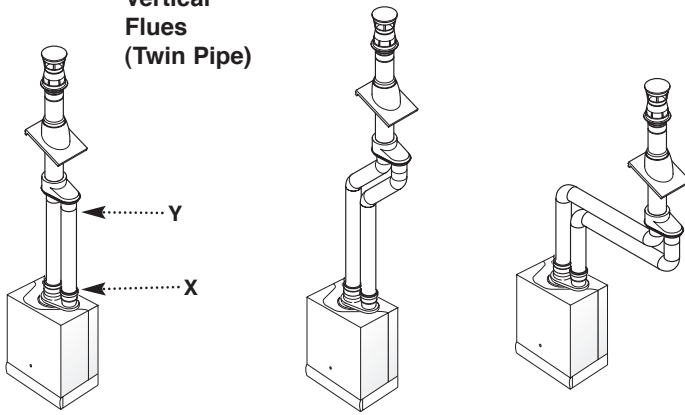

Vertical Flues

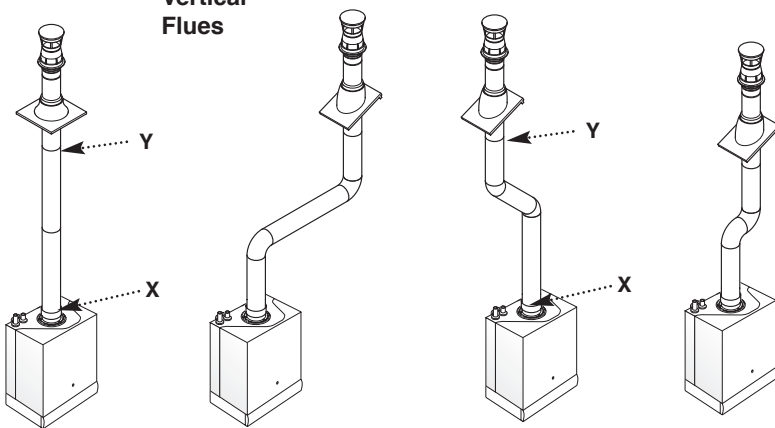

Total Equivalent Length = A+B+C+1x90° Bend

All vertical and angled runs must be included, measured from the boiler adaptor (point X) to the joint with the flue terminal (point Y). One 91.5° bend or two 135° bends can be included without reduction of the flue length.

If further elbows are required the flue length must be reduced by the following amounts:-

- 1 metre for each 91.5° bend
- 0.5 metre for each 135° bend

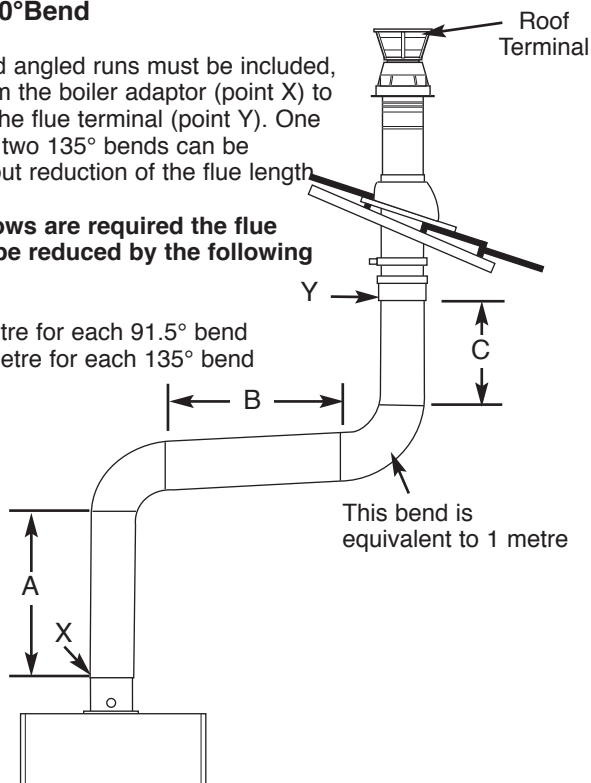

3.8.3 Twin & Vertical Flue Systems

1. Maximum permissible equivalent flue lengths are:-

Vertical Concentric	1.9m
Vertical Twin Pipe	6m*

* Both the air and flue duct can be up to 6 metres long each.

2. Any additional "in line" bends in the flue system must be taken into consideration. Their equivalent lengths are:-

Concentric Pipes:

135° bend	0.5 metres
93° bend	1.0 metres

Twin Flue Pipe

135° bend	0.25 metres
91.5° bend	0.50 metres

The elbow supplied with the standard horizontal flue is not included in any equivalent length calculations

NOTE: Flue length is measured from point X to Y as shown.

Important: All flue systems must be securely supported at least once every metre. Suitable pipe supports are available as accessories.

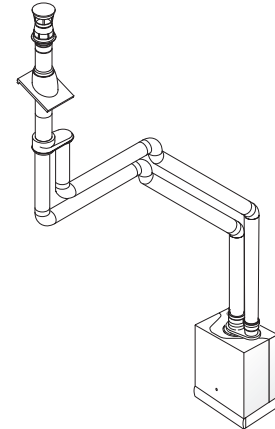

The total equivalent length for this example is = 5.5 metres.

AIR DUCT		
Equivalent Length Value	N° of fittings/pipes	Sub total
1m extension	4	4.0m
135° bend	2	0.5m
91.5° bend	2	1.0m
Equivalent Length Air Duct = 5.5m		

FLUE DUCT		
Equivalent Length Value	N° of fittings/pipes	Sub total
1m extension	4	4.0m
135° bend	2	0.5m
91.5° bend	2	1.0m
Equivalent Length Flue Duct = 5.5m		

3.8.4 Flue Accessories

Key No	Accessory	Size	Baxi Code
--------	-----------	------	-----------

FLUE GROUP A

Concentric Flue System 100mm diameter

A3	Telescopic Internal Flue Kit 315-500mm		5119654
A2	Telescopic Flue (incl elbow)		5118069
A	Horizontal flue Terminal (incl elbow)		5118489
B	Flue extension	1000mm	5111074
C	Flue Bend	93°	5111075
D	Flue Bend (pair)	135°	5111085
U	Pipe support (painted)	100mm	5111080
R	Vertical flue adaptor (use with 5111078)		5111070
T	Vertical flue boiler adaptor		5111065
P	Wall Liner		5111067
S	Flue Terminal Deflector		5111068

FLUE GROUP N

Twin Flue System 80mm diameter

E	Flue extension (pair)	1000mm	5111087
F	Flue Bend (pair)	90°	5111072
G	Flue Bend (2 pair)	135°	5111086
O	Vertical flue boiler adaptor kit		5111071
H	Vertical flue adaptor		5111084
W	Pipe support (pair)	80mm	5111081

FLUE GROUP A, N,

Vertical Flue Kits

K	Vertical flue terminal (use with 5111070)		5111078
L	Lead tile	25°/50°	5122151
M	Roof cover plate		246143
N	Flat roof flashing		246144

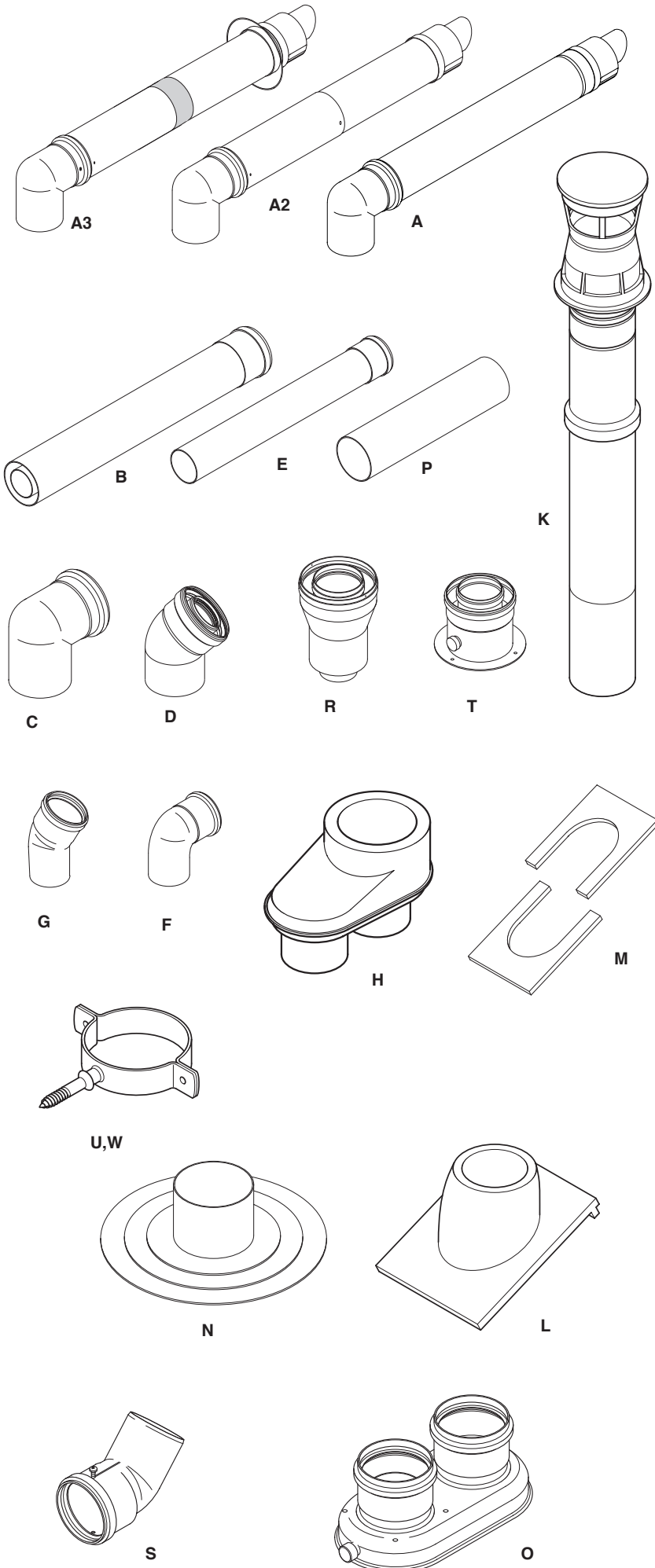

For Twin Flue Systems fit the adaptors as follows:-

3.8.5 Vertical Flue Duct Adaptor (Fig. 11)

1. Remove the flue elbow from top of the boiler and replace with the vertical flue duct adaptor ensuring the existing gasket is still in place.

3.8.6 Twin Vertical Flue Boiler Adaptor (Fig. 12)

1. Remove the flue elbow from top of the boiler and replace with the twin vertical flue duct adaptor ensuring the existing gasket is still in place.
2. Attach the rubber spacer to the base of the adaptor.
3. Fit the adaptor to the top of the boiler and secure it to the four hole fixing plate using the long screws supplied.
4. Continue to fit the twin flue system.

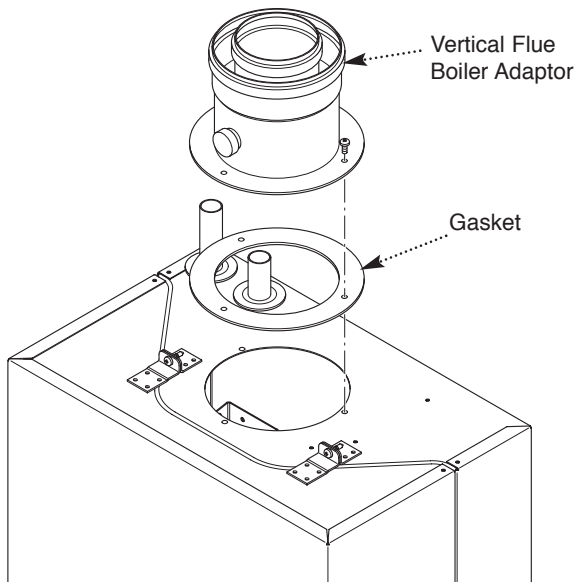

Fig. 11

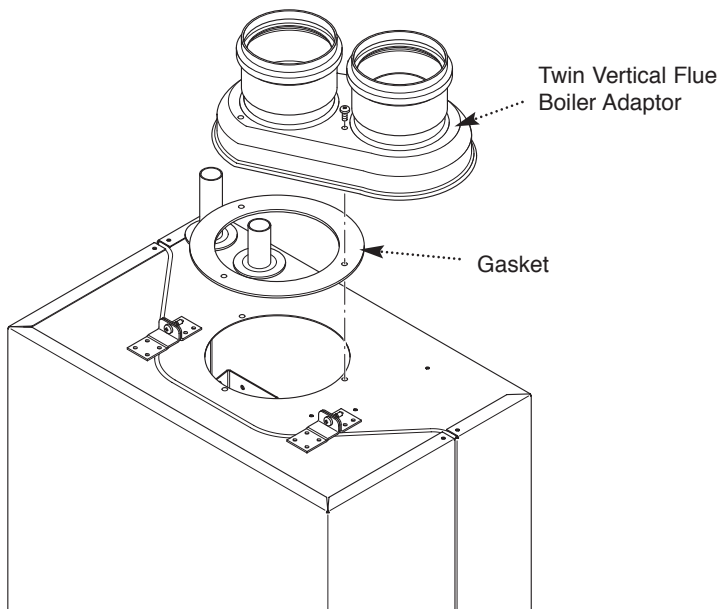
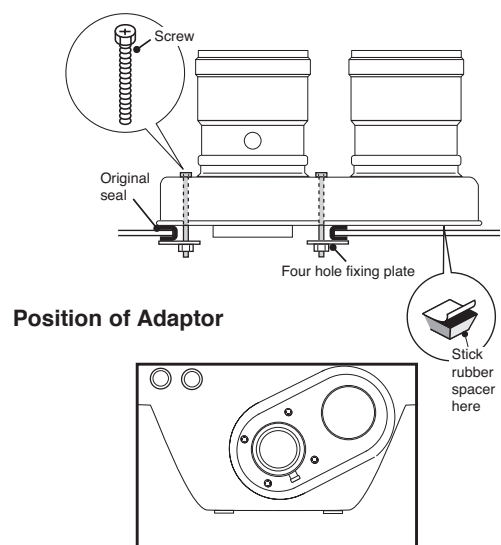
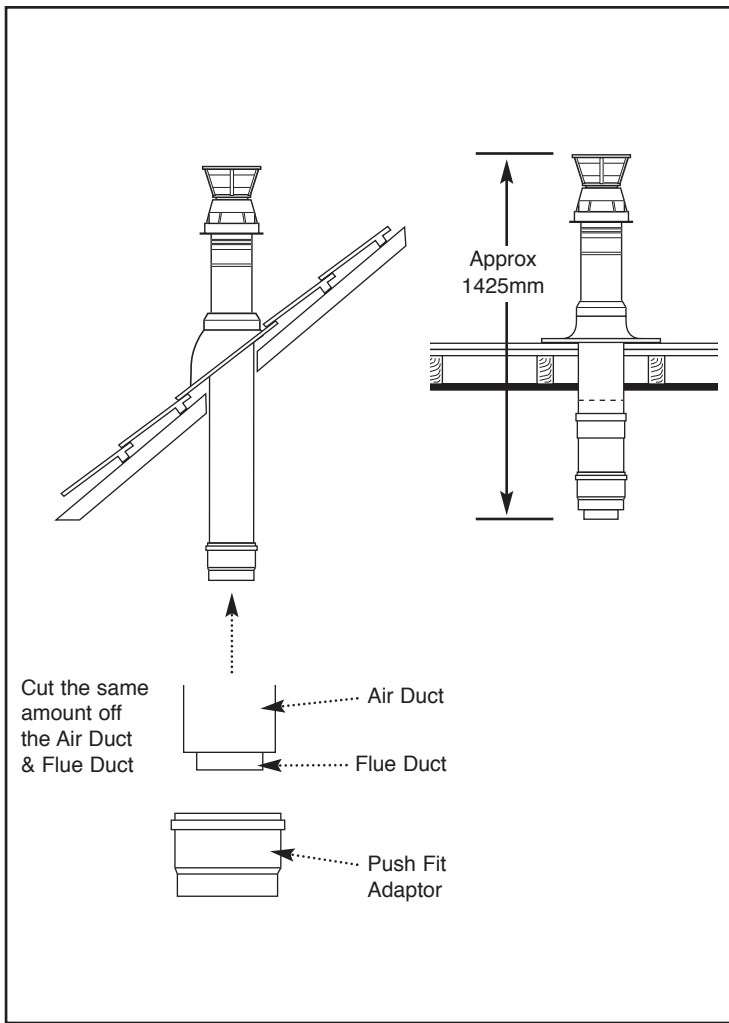

Fig. 12





3.8.7 For Roof Terminals

1. In the case of a pitched roof 25 - 50 degrees, position the lead tile to replace/flash over existing roof tiling. Make an aperture in the roof suitable for the lower tube of the roof terminal and ensure the integrity of the roof cover is maintained. The adjustable plastic collar can either be positioned on the lead tile or the lower tube of the roof terminal prior to the final positioning of the vertical flue through the tile. Check the collar is correctly located to suit required roof pitch (either 25° to 38° or 37° to 50°). From inside the roof adjust the flue to a vertical position and secure to the roof structure with the clamp supplied.

2. For flat roof installations the aluminium flashing must be incorporated into the roof covering and the appropriate aperture made in the roof decking. The vertical flue is lowered onto the flashing making sure the collar of the flue locates securely with the flashing. (A mastic seal may be necessary). From inside the roof, adjust the flue to a vertical position and secure to the roof structure with the clamp supplied.

3.8.8 Flue Dimensions

The standard horizontal flue kit allows for flue lengths between 100mm and 685mm from elbow to terminal (Fig. 13).

The maximum permissible equivalent flue length is: 3.55 metres

NOTE: Each additional 45° of flue bend will account for an equivalent flue length of 0.5m.

eg. 45° = 0.5m, 90° = 2 x 45° = 1m etc.

3.8.9 Flue Trim

1. The rubber flue trim supplied may be fitted to either the outside wall or on the inner wall of installation.

3.8.10 Terminal Guard (Fig. 14)

1. When codes of practice dictate the use of terminal guards, they can be obtained from most Plumbers' and Builders' Merchants.

2. There must be a clearance of at least 50mm between any part of the terminal and the guard.

3. When ordering a terminal guard, quote the appliance name and model number.

4. The flue terminal guard should be positioned centrally over the terminal and fixed as illustrated.

3.8.11 Flue Deflector (Fig. 13a)

1. If required a flue deflector is available from your Main stockist.

2. Push the flue deflector over the terminal end and rotate to the optimum angle for deflecting plume. Secure the deflector to the terminal with screws provided.

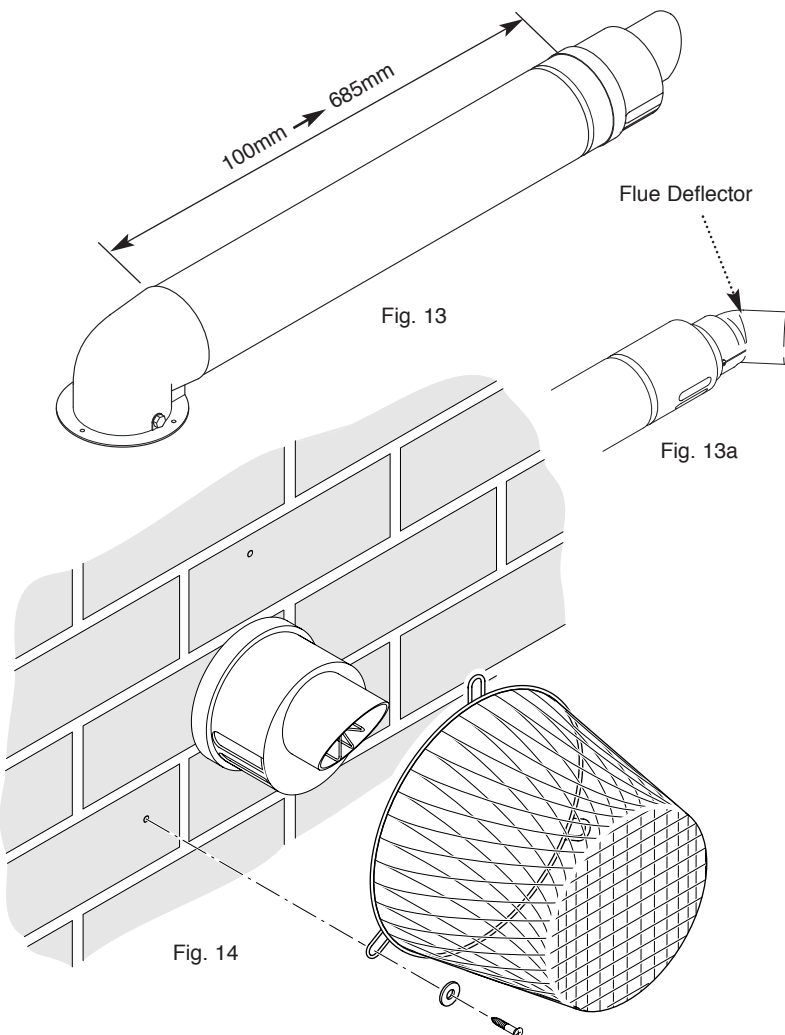

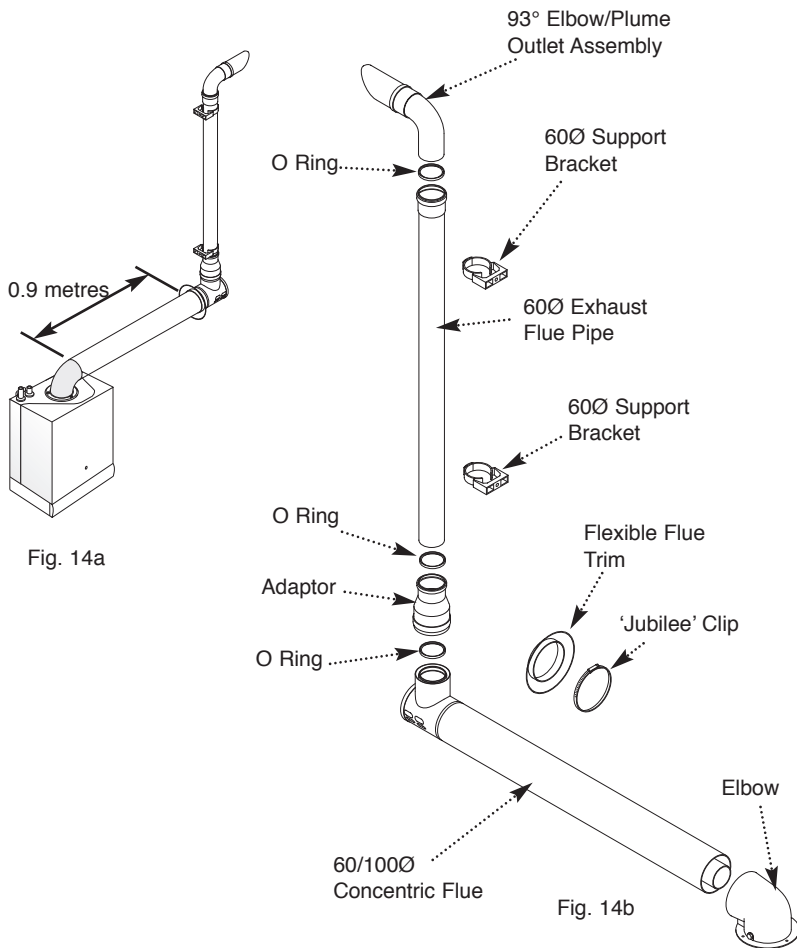

3.9 Plume Displacement Kit (Fig. 14b)

Kit No 5118638

Content of kit

1	0.9m 60/100 Concentric Flue
1	1m 60 Dia Exhaust Flue Pipe
1	Adaptor
2	60 Dia Support Brackets
1	93° Elbow/Plume Outlet Assembly
1	Flexible Flue Trim
3	"O" Rings
1	'Jubilee' Clip
1	Boiler Elbow

1. This kit is recommended for installations where the condensate plume emitted from the flue may cause a nuisance or affect the surroundings.

2. The terminal must be positioned outside the building with the air inlet facing downward and outlet connection upwards.

3. The plume outlet must always be at least 45° to the wall, with the 'peak' uppermost to prevent rain entry (Figs. 15 & 16), and be at least 2 metres above ground level. It must be secured as shown in Fig. 12a. The plume outlet must also be at least 500mm from the air inlet in any direction (Fig. 16).

NOTE: The outlet must be positioned so that any condensate plume is directed away from adjacent surfaces. There must be a constant fall along the entire length of the flue system from the outlet back to the boiler.

4. It is possible to reduce or increase (with the addition of extensions) the length of either or both the 60/100 concentric and 60Ø exhaust.

5. Standard concentric flue extension kits may be added between the boiler elbow and the terminal assembly.

6. The minimum length of the concentric flue is 100mm when measured from the edge of the flue elbow.

IMPORTANT: The maximum equivalent length of concentric flue is:-

3.55 metres Main (9,12,15,18 HE)

3.0 metres Main (24 HE)

Additional bends may be fitted in the concentric flue, but the equivalent length must be reduced by 1 metre (93° elbow) or 0.5 metres (45° elbow).

7. 60Ø 1 metre extensions (including support bracket), and additional 93° & 45° elbows are available. Any additional 93° & 45° elbows must be accounted for when calculating flue lengths.

NOTE: Permitted positions of the plume outlet relative to doors, windows etc. are the same as for conventional concentric flues as detailed in the main Installation & Servicing Instructions and BS5440 Pt. 1. It is **NOT** necessary to fit a terminal guard over the air inlet or the plume outlet.

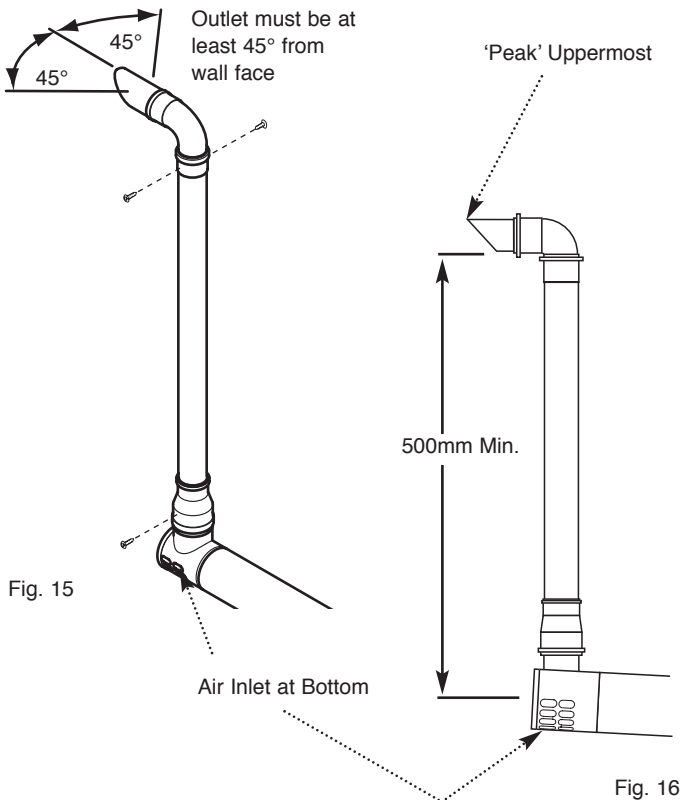

Graph Line F is suitable for Main 9, 12, 15, 18 HE
 Graph Line G is suitable for Main 24 HE

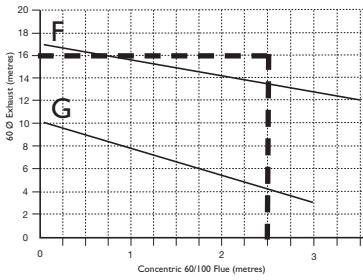

Example 1
Flue Lengths - Not Permissible

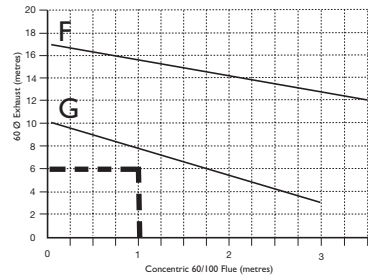

Example 2
Flue Lengths - OK

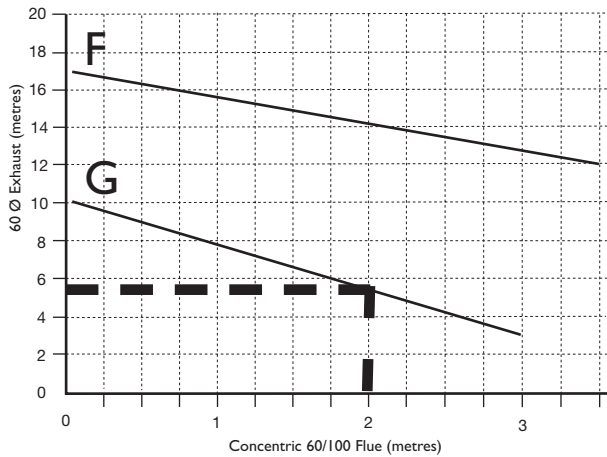

Example 3
Flue Lengths - OK

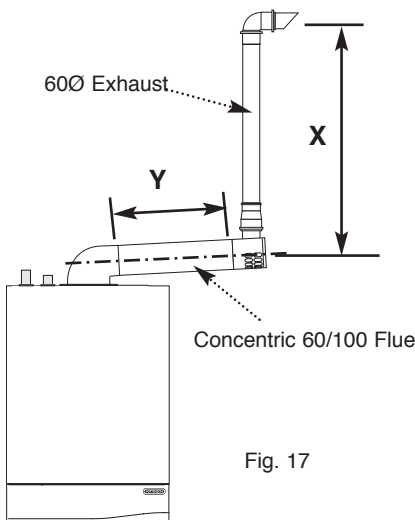

Fig. 17

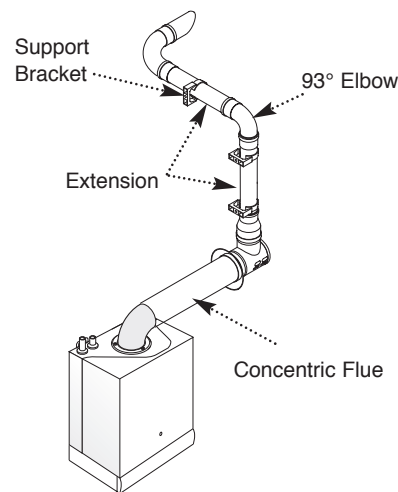

Fig. 18

Additional Accessories

A - 93° Elbow	5117381
B - 45° Elbow (Pair)	5117382
C - 1 metre 60Ø Extension	5117380

3.9.1 Determining Permissible Lengths

In the graph the solid line diagonal represents the relationship between the concentric flue assembly (and any extensions) and the 60Ø exhaust (and any extensions or additional bends).

Example 1 - Not Permissible

If, for instance, a concentric length of 2.5 metres was required and the 60Ø exhaust needed to be 16 metres the graph shows that this combination would NOT be permissible as the intersection point would be above the solid diagonal line.

Example 2 - Flue Lengths OK

Where both lengths have been determined they can be applied to the graph to check that the installation is permissible. For example, if it was known that 1 metre of concentric flue and 6 metres of 60Ø exhaust were required, the values could be applied to the graph as shown in Example 2. As the point of intersection of the dotted lines is below the solid diagonal line, the combination of lengths is shown to be acceptable.

Example 3 - Flue Lengths OK

In the example shown, assume that the concentric part of the flue needs to be 2 metres long. Find the position of '2' on the horizontal axis of the graph and then project upwards to the solid diagonal line. This is represented by the vertical thick dotted line. Where this dotted line intersects with the solid diagonal line on the graph, project across to the vertical axis. As can be seen this corresponds with 5.5 metres. Therefore, the total equivalent length of the 60Ø exhaust can be up to 5.5 metres. Any elbow equivalences must be accounted for i.e. 93° elbows are equal to 1 metre, each 45° elbow to 0.5 metres.

Flue Length - Worked Example
 Main 24 HE

In Fig. 18 opposite an additional 93° elbow has been included in the 60Ø exhaust. with 2 x 1 metre extensions which have been cut to 0.25metres and fitted. The waste is discarded.

To calculate total length:-

2 x 0.25 metre Lengths =	0.5 metres
1 x 93° Elbow =	1 metre
Total 60Ø Exhaust =	1.5 metres

After consulting the table in Example 3 it can be determined that the concentric flue could be up to approximately 6.25 metres long.

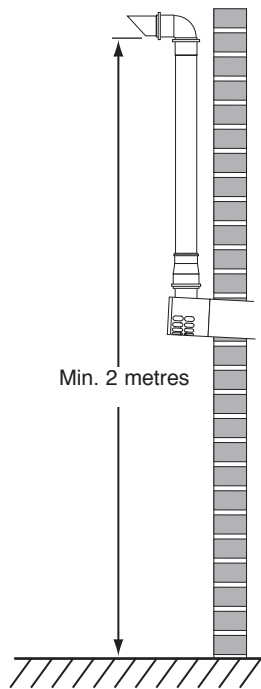

Fig. 19

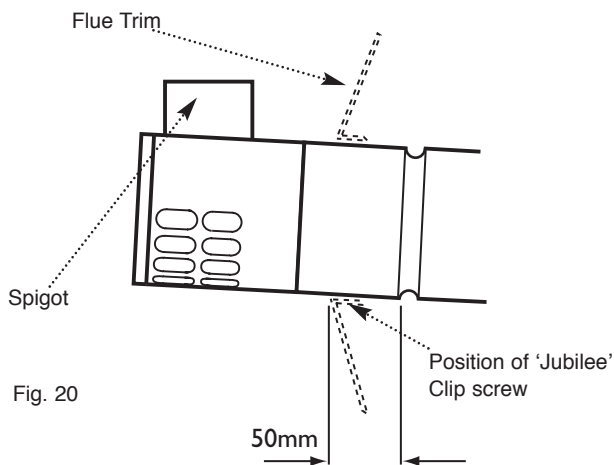

Fig. 20

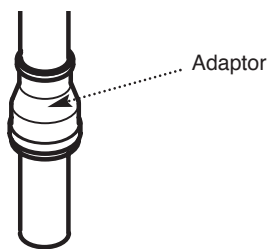

Fig. 22

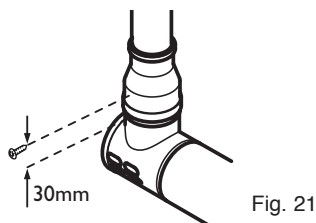

Fig. 21

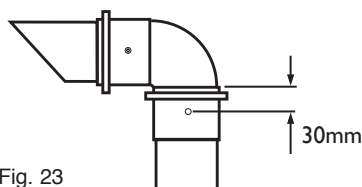

Fig. 23

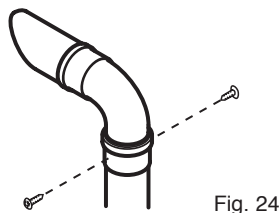

Fig. 24

3.9.2 General Fitting Notes

1. Cut a hole in the external wall which the concentric flue assembly will pass through. The hole should allow the flue to fall back to the boiler at an angle of at least 1.5°.
2. When completed the terminal must be at least 2 metres above ground level (Fig. 19).
3. Measure and cut to size the concentric assembly and any extensions that are being used.
4. Insert the concentric assembly through the hole from outside the building.
5. If required, the flexible flue trim should be fitted prior to this as it cannot be fitted after. Use the large 'Jubilee' clip to secure the trim to the flue (See Fig. 20, trim shown dotted), with the screw part of the clip at the bottom.
6. Connect any extensions or elbows that are being used to the concentric assembly. Engage the extension, elbow or concentric assembly in the boiler flue elbow. Fit the boiler flue elbow to the boiler adaptor.
7. Ensure that the concentric assembly and any extensions fall back to the boiler at an angle of at least 1.5° and that the external air inlet is to the bottom.
8. Use suitable brackets to support the concentric assembly and any extensions, and make good inside and outside.
9. The 60Ø exhaust can now be fitted. Slide the adaptor over the plain end of the 60Ø exhaust (Fig. 22) and engage the exhaust in the terminal. Slide the adaptor down over the spigot. Mark and drill the adaptor, using a 2mm bit, as shown in Fig. 21. Secure the adaptor to the spigot using one of the screws supplied.
10. If it is necessary to shorten the 60Ø exhaust or any of the extensions, the excess material must be cut from the plain end of the pipe.
11. Determine the position of the 60Ø exhaust and mark on the wall a suitable position for the support bracket. If extensions are being used, a support bracket is supplied in each kit.
12. Drill the wall, and fit the bracket(s) using the plug and screw provided.
13. Mark and drill the 60Ø exhaust, using a 2mm bit, as shown in Fig. 23. Complete the installation of the 60Ø exhaust, securing in the brackets.
14. Fit the 93° elbow/plume outlet and secure with the two remaining screws supplied. Ensure the plume outlet is at least 45° to the wall and that the 'peak' is uppermost (Fig. 24).

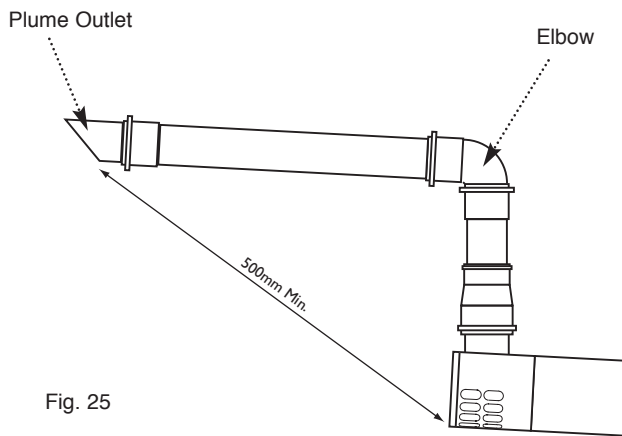

Fig. 25

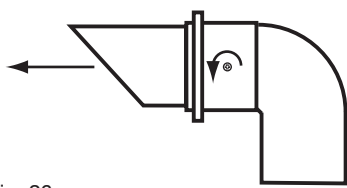

Fig. 26

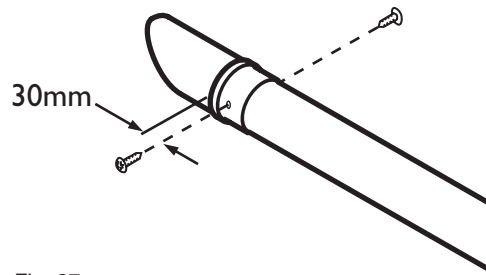

Fig. 27

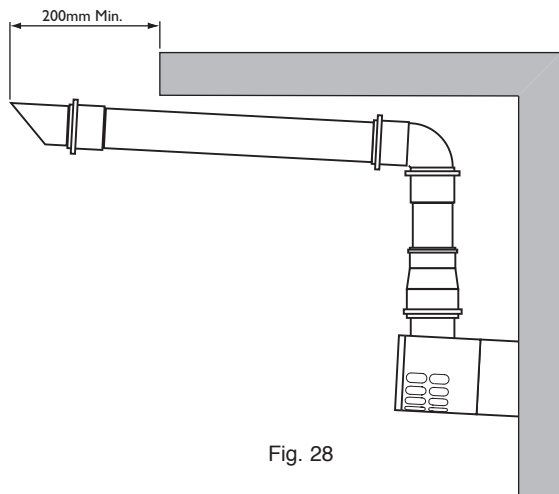

Fig. 28

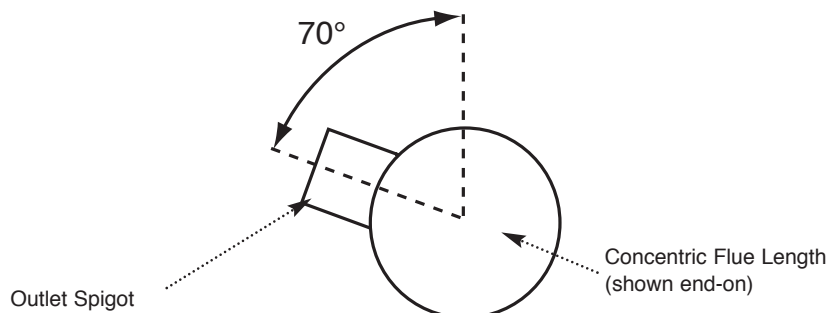

Fig. 29

3.9.2 General Fitting Notes (cont.)

15. For aesthetic purposes it is permissible to route the 60Ø exhaust in an enclosed box, but the air inlet and plume outlet MUST remain in free air.

16. It is also possible to separate the plume outlet from the 93° elbow to allow the flue to be installed as shown in Fig. 25.

17. To do this, first slacken the two screws retaining the plume outlet to the elbow, and remove the outlet (Fig. 26). The elbow can now be used to connect the vertical to horizontal 60Ø exhaust (Fig. 25). Retighten the screws in the elbow.

18. The outlet can now be fitted into the female end of an 60Ø extension piece. It must be secured using two of the screws supplied in the bag with the 'Jubilee' clip.

19. Mark the female end of the extension at 30mm as shown in two positions, directly opposite each other (Fig. 27).

20. Using a suitable bit (e.g. 2mm), drill through the extension and outlet. Secure using two of the screws supplied.

21. The remaining screw must be used to secure the adaptor to the concentric terminal.

22. When the plume outlet is positioned under a balcony or other projection (Fig. 28) it must protrude at least 200mm (it is not necessary to extend it further than this).

23. When under balconies or projections it is permissible to rotate the concentric flue length up to 70°, clockwise or anti-clockwise (Fig. 29), if there is insufficient space to connect vertically.

24. This will allow the connection of the exhaust to the outlet spigot.

25. All other minimum & maximum dimensions must be adhered to, and the air inlet positioned such that it will not be subject to rain entry.

3.10 Water Circulating Systems

The boiler is suitable for use with fully pumped open vented and sealed systems with an indirect coil type high efficiency cylinder.

The following conditions should be observed on all systems:

- The static head must not exceed 30.5 m (100ft) (3 bar) of water or be less than 150 mm (6 in).
- The flow pipe from the boiler must always be higher than the return pipe.
- To ensure correct operation, the pump must be wired to the boiler terminal block.

3.10.1 Treatment of Water Circulating Systems

All recirculatory water systems will be subject to corrosion unless they are flushed and an appropriate water treatment is applied.

To prevent this, follow the guidelines given in BS 7593 "Treatment of water in domestic hot water central heating systems" and the treatment manufacturers instructions.

Failure to flush and add inhibitor to the system may invalidate the boiler warranty.

Treatment must involve the use of a proprietary cleanser, such as BetzDearborn Sentinel X300 or X400, or Fernox Superfloc and an inhibitor such as BetzDearborn Sentinel X100, or Fernox MB-1 or Copal.

Full instructions are supplied with the products, for further information contact BetzDearborn (+44 151 420 9563) or Fernox (+44 1799 550 811) directly.

It is important to check the inhibitor concentration after installation, system modification and at every service in accordance with the inhibitor manufacturer's instructions. (Test kits are available from inhibitor stockists.)

3.10.2 System Design

Pipe Sizing

The flow and return connections on the boiler are 22 mm. The sizes of the system flow and return pipes from the boiler should be determined by normal methods, according to the system design requirements. See Fig. 30. and Table 2.

Air Vents

It is recommended that automatic air vents are fitted within the system pipework to prevent air locks during filling, commissioning and normal operation.

To ensure correct circulation, it is essential to vent all air from the system prior to commissioning the boiler.

System Drain Off Points

Drain off points should be fitted in the pipework close to the boiler and in the low points of the system.

Plastic Pipework

If plastic pipe is used for the central heating circuit there must be a run of at least 2 metres of uninsulated copper pipe from the boiler flow and return connections including any branches.

3.10.3 Bypass Requirements

The system must be designed to always provide a route for water to circulate between the boiler flow and return. Best Practice is to use an automatic bypass although it may be possible to use an existing fixed bypass such as a landing or bathroom radiator fitted with two lockshield valves or a bypass fitted with a balancing valve. See Fig. 30.

Systems with Two Port Valves

Where a pair of two port zone valves are used, the total length of the by-pass circuit taken from the boiler connections should be greater than 4 metres of 22 mm pipe. The bypass should be capable of maintaining a minimum flow through the boiler of 4.5 litres/min (1 gal/min).

Systems with Thermostatic Radiator Valves (TRV's)

Where mechanically operated thermostatic control valves are used, the total length of the by-pass circuit taken from the boiler connections should be greater than 2 metres of 22 mm pipe. The bypass should be capable of maintaining a minimum flow through the boiler of 9.0 litres/min (2 gal/min).

3.10.4 System Controls

For optimum operating efficiency, the heating system into which the boiler is installed should include a control system. Best Practice suggests such a system should comprise: a programmer, room and cylinder thermostats, control valves giving boiler interlock.

Frost Protection - System

The system pipework may require insulation and the protection of an additional frost thermostat.

If the system is drained isolate the external gas and electrical supplies.

3.10.5 Boiler Protection

- A frost thermostat is fitted within the boiler controls which operates even if the temperature control knob is at the (●) position. The boiler will operate as necessary to maintain the boiler temperature above freezing.
- The boiler is fitted with a timed pump overrun that will operate for around 2 minutes after boiler shutdown.
- The boiler control will operate the pump for around 2 minutes every 24 hours to maintain free running of the pump.

3.10.6 Pump Requirements

- Resistance through the heat exchanger is shown in the graph and Table 2 opposite.
- If other control valves are used in the system the resistance through them, quoted in their manufacturers literature must be taken into account.

3.10.7 Further Details

- Further details on systems are shown in BS5449 and BS6798

Hydraulic resistance

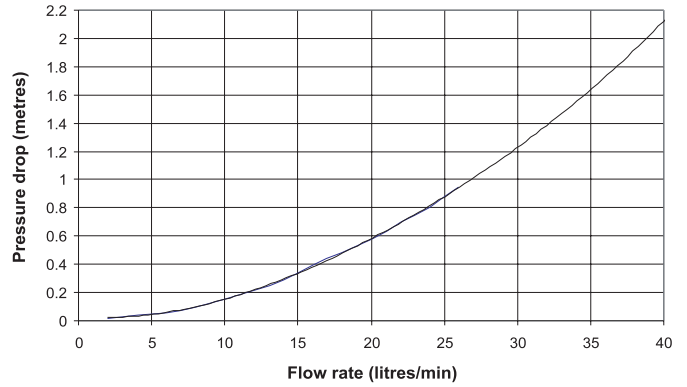

	Min. 11°C			Max. 20°C		
	Water Flow Rate (l/min) and Boiler Resistance (mbar/m)					
	l/min	mbar	m	l/min	mbar	m
9 HE	11.5	21.2	0.22	6.3	6.3	0.06
12 HE	15.2	34.1	0.35	8.4	10.8	0.11
15 HE	19.2	53.0	0.54	10.6	16.9	0.17
18 HE	22.9	73.5	0.75	12.6	23.7	0.24
24 HE	30.5	124.6	1.27	16.8	41.2	0.42

Table 2

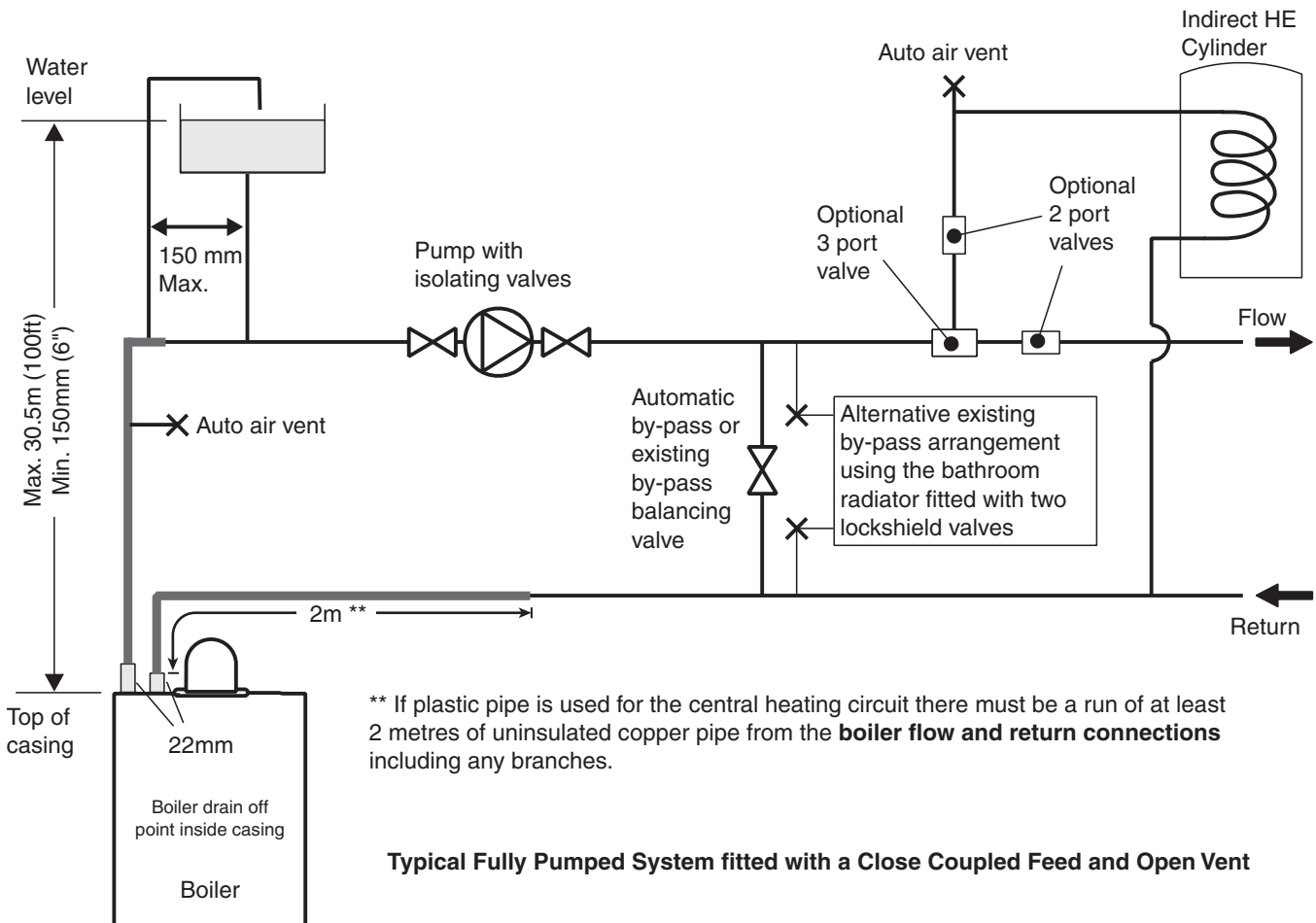

Fig. 30

3.10.6 Sealed Systems

System Components

All components used in the sealed system must be suitable for operation at 110°C and at the maximum pressure allowed by the pressure relief valve (normally 3 bar).

Pressure Relief Valve

A pressure relief valve, set to a maximum 3 bar opening pressure must be fitted.

Pressure Relief Valve Discharge Pipe

The pressure relief valve discharge pipe should be not less than 15mm diameter and run continuously downward. It should be routed in such a manner that no hazard occurs to occupants or damage caused to wiring or electrical components.

Consideration must be given to the possibility that boiling water/steam could discharge from the pipe.

The discharge must be outside the building, but must not be above a window, entrance or other public access.

The end of the pipe should terminate facing down, towards the wall and preferably over a drain.

Pressure Gauge

A pressure gauge of minimum range 0-4 bar with a fill pressure indicator must be connected to the system, preferably at the same point as the expansion vessel in a position easily visible from the filling point.

Expansion Vessel

An expansion vessel complying with the requirements of BS 4814 must be connected to the system close to the inlet side of the circulating pump in accordance with the manufacturers instructions, the connecting pipe being unrestricted and not less than 15mm nominal size.

The volume of the vessel should be suitable for the system water content and the nitrogen or air charge pressure should not be less than the system static head.

Calculation

To size the expansion vessel it is first necessary to calculate the volume of water in the system in litres. The following volumes may be used as a conservative guide to calculating the system volume.

Boiler Heat Exchanger:	2.7 litres
Small Bore Pipework:	1 litre per kW of system output
Micro Bore Pipework:	7 litres
Steel Panel Radiators:	8 litres per kW of system output
Low Water Capacity Radiators:	2 litres per kW of system output
Hot Water Cylinder:	2 litres

The vessel size can now be determined from the information in Table 3 where V = System size in litres.

Vessel Charge Pressure (bar)	0.5	1.5
Initial System Pressure (bar)	1.0	1.5
Expansion Vessel Size (litres)	V x 0.11	V x 0.125

Table 3

Where a vessel of the calculated size is not available, the next available larger size should be used.

If the system is extended, the expansion vessel volume may have to be increased unless provision has been made for extension.

Filling Point

A filling point connection on the return pipework must be provided to facilitate initial filling and pressurising and any subsequent water loss replacement/refilling.

The filling method adopted must be in accordance with all relevant water supply regulations and use approved equipment. Your attention is drawn to, in GB, Guidance G24.2 and recommendation R24.2 of the Water Regulations Guide. and IE, the current edition of I.S. 813 "Domestic Gas Installations".

The system may be filled or replenished by means of a temporary connection between the circuit and a supply pipe, provided a 'Listed' double check valve or some other no less effective backflow prevention device is permanently connected at the inlet to the circuit and the temporary connection is removed after use - See Fig. 32.

Further Details on Sealed Systems

Further details of sealed system design are shown in BS5449, BS6798 and BS7074.

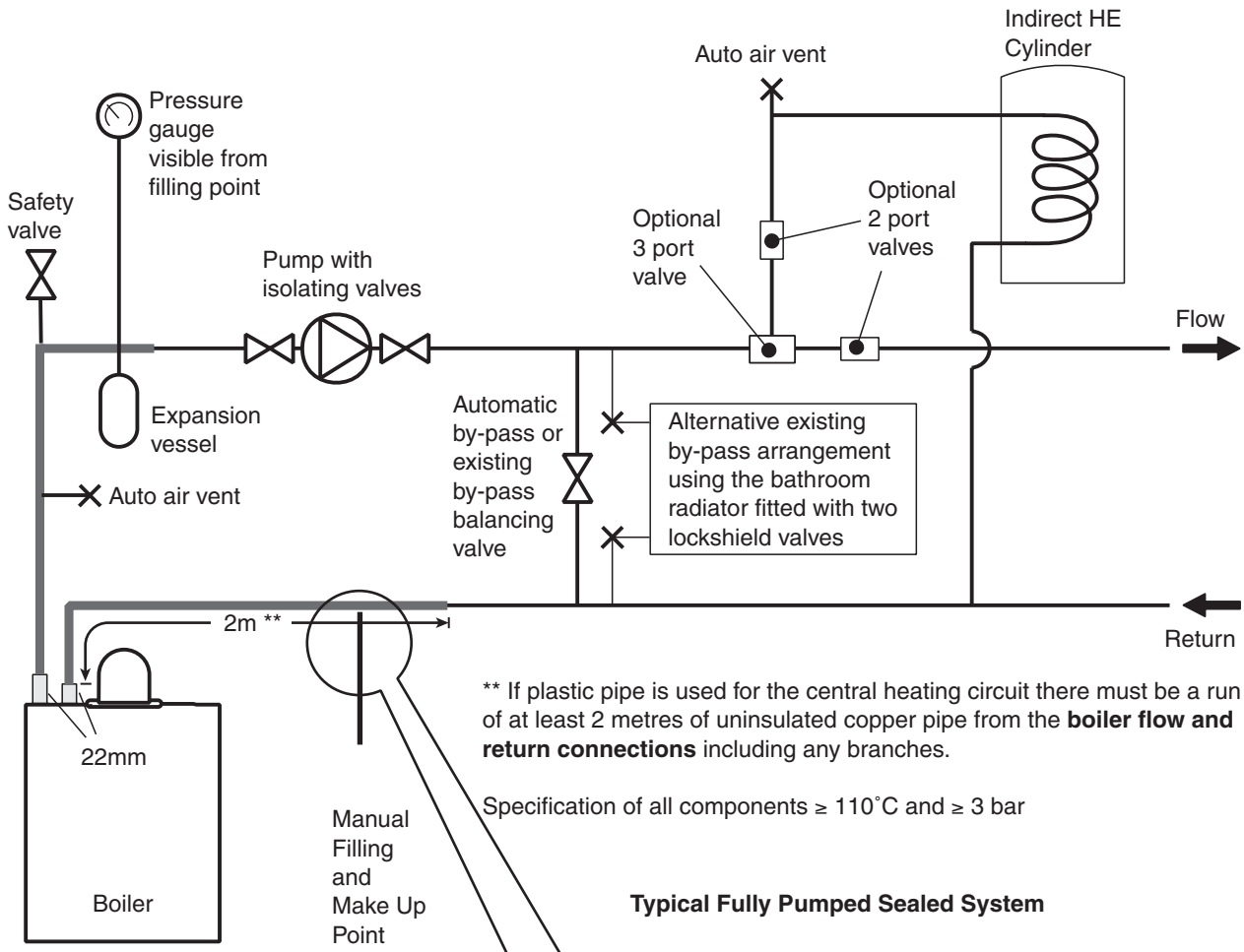

Fig. 31

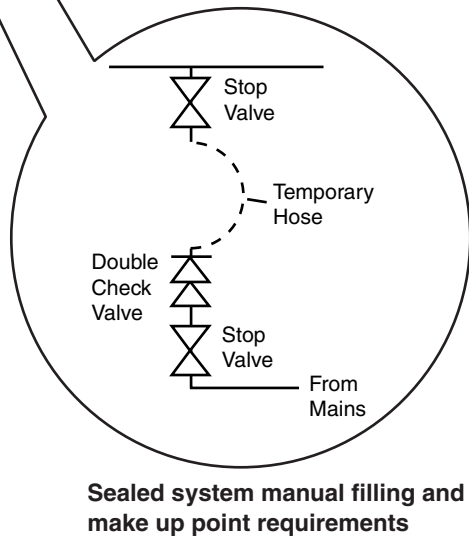

Fig. 32

4. Installation

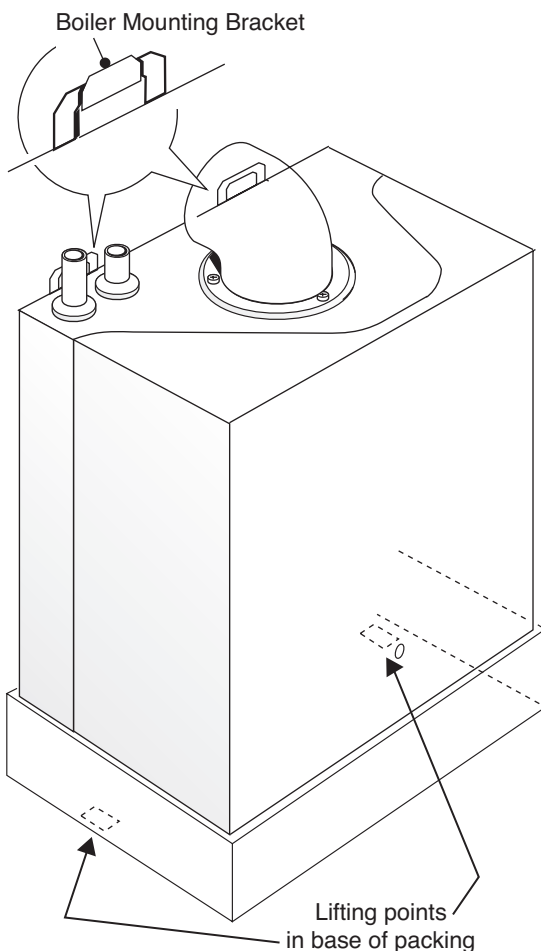
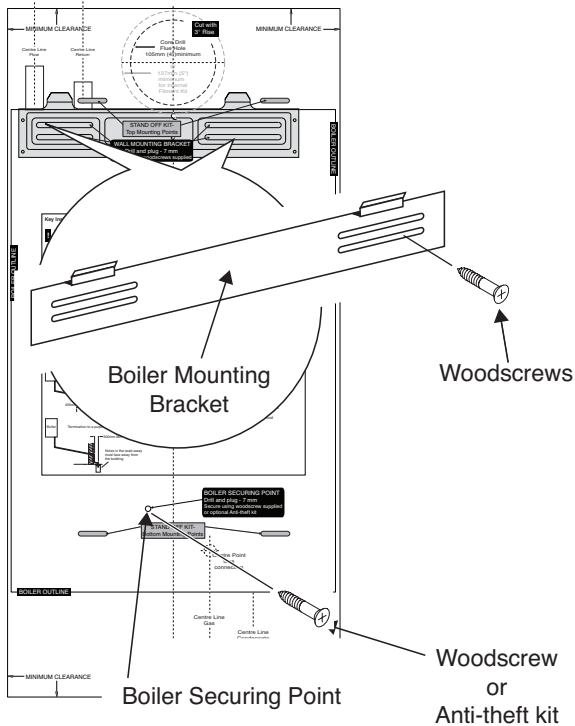

Fig. 33

4.1 Unpack & Prepare the Wall & Boiler

These instructions assume you have chosen a suitable boiler location which will also allow correct installation of the condensate and flue systems.

1. Carefully unpack the boiler, **leave the packing around the base of the boiler fitted**. Do not discard other packaging until all the items are accounted for and/or the boiler is installed.
2. Place the mounting template in the proposed boiler position ensuring that it is level.

Minimum clearances, fixing points, pipework centrelines and flue incline are all accounted for on the template.

3. Mark the flue hole, mounting bracket fixing positions (two), boiler securing point and pipework centre lines then remove the template.
4. Drill (7 mm drill) and plug the three mounting holes.

Drill (on an incline, approx. at least 1.5° to ensure the condensate drains back to the boiler) a 105mm diameter hole for the flue through the wall or a 127mm diameter hole if the Internal Fitment Kit is being used.

5. Secure the mounting bracket to the wall using two No. 12 x 2" woodscrews (supplied).
6. Lift the boiler **by the packing at the base** onto the mounting bracket.
7. Remove the packing from the base and square boiler to the wall using the alignment screws on the back panel. Pull the door panel down and remove the two securing screws. Slide off the controls cover assembly and put safely aside.
8. **Ensure the boiler is secured to the wall** (using the third No. 12 x 2" woodscrew) through the hole in the bracket at the rear of the boiler case.

Note: The anti-theft securing kit (Part No. 238035POT) may be used in place of the third woodscrew if required.

4.2 Install the Flue

These instructions are for standard horizontal rear and side flue applications which have a maximum horizontal installed length of 700 mm when fitted.

The flue elbow is supplied set to the rear. For side outlet slacken the screws and turn the elbow to the required position and re-tighten screws. Ensure all flue elbow seals are still correctly located.

If using a left hand side flue application we recommended you make the flow and return water connections before fitting the flue.

1. Measure dimension X from the centre point of the flue elbow to the outside of the wall and add 50 mm.
2. Mark the dimension to be cut onto the flue as shown. Re-check measurements and ensure the inner flue support bracket is pushed beyond the cut line before cutting.

Cut outer tube and then cut the inner tube flush with the outer. Deburr both tube ends.

3. Slide the wall seal along the flue and into position behind the terminal.
4. To ease assembly of the flue system apply the silicone grease (provided) to the inner seal of the flue elbow. Pass the flue through the wall and push firmly into the flue elbow. The flue is correctly located when the visual check holes are blocked.
5. Ensure the terminal shroud is vertical as shown opposite.
6. Make good the wall around the flue.
7. Refer to Page 17 for flue deflector and or terminal guard requirements

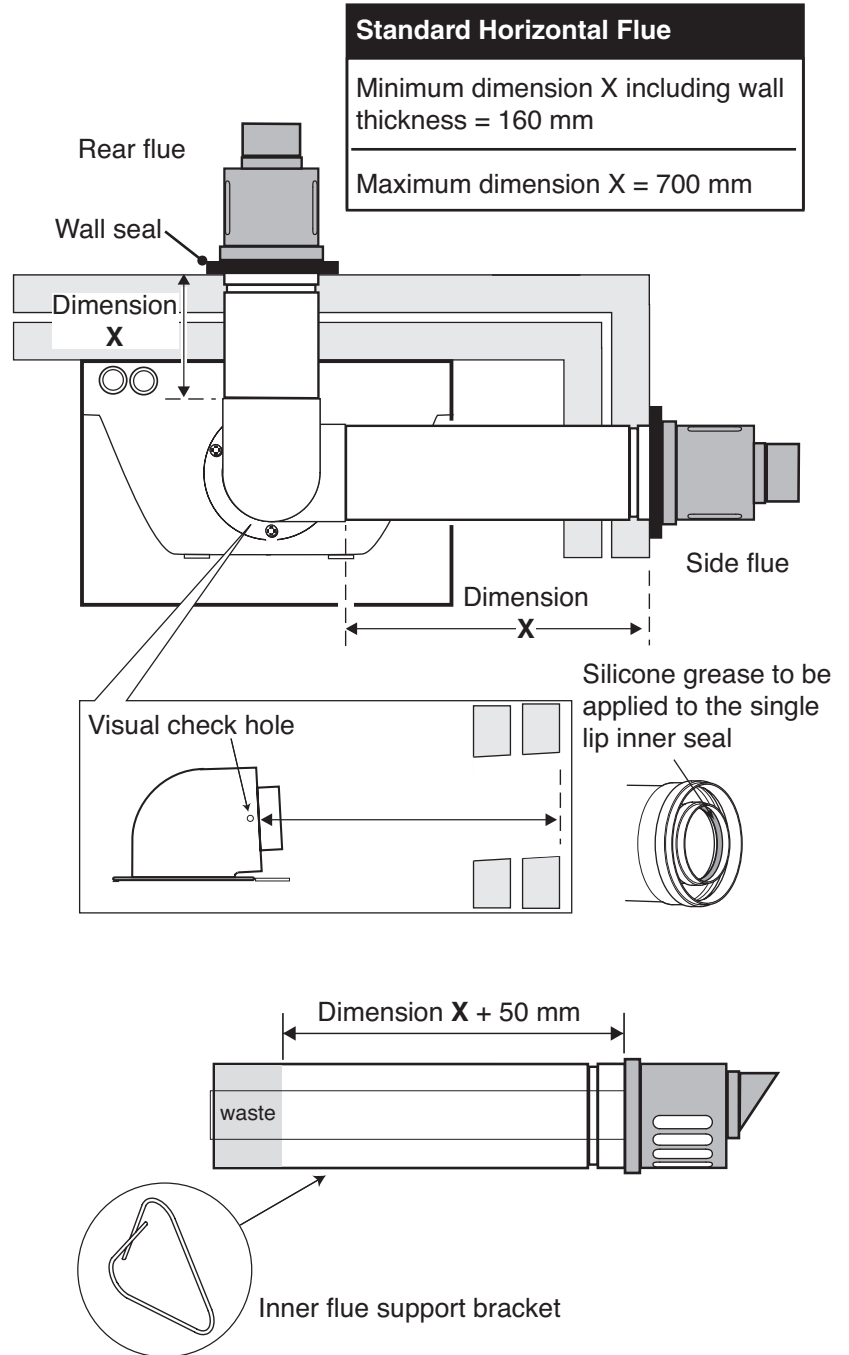

Silicone Grease Safety Data

The grease supplied is not regarded as a health or environmental hazard under current legislation.

First Aid Measures

Inhalation - Not relevant

Ingestion

Never make an unconscious person vomit or drink fluids ! Rinse mouth thoroughly and drink plenty of water. Get medical attention if any discomfort continues.

Skin Contact

Remove affected person from source of contamination. Get medical attention if irritation persists after washing.

Eye Contact

Make sure to remove any contact lenses from the eyes before rinsing. Promptly wash eyes with plenty of water while lifting the eye lids. Continue to rinse for at least 15 minutes. Get medical attention if any discomfort continues.

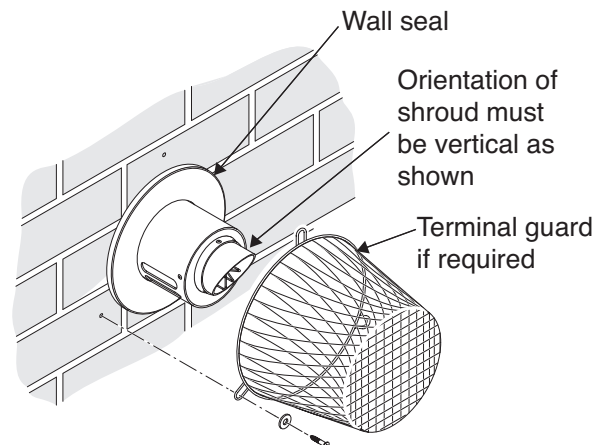

Fig. 34

Schematic wiring with boiler interlock

There **must** be both mains Permanent Live and Switched Live from the system to the boiler terminal block for the boiler protection devices to operate correctly.

The pump **must** be wired to the boiler terminal block for the pump overrun to operate correctly.

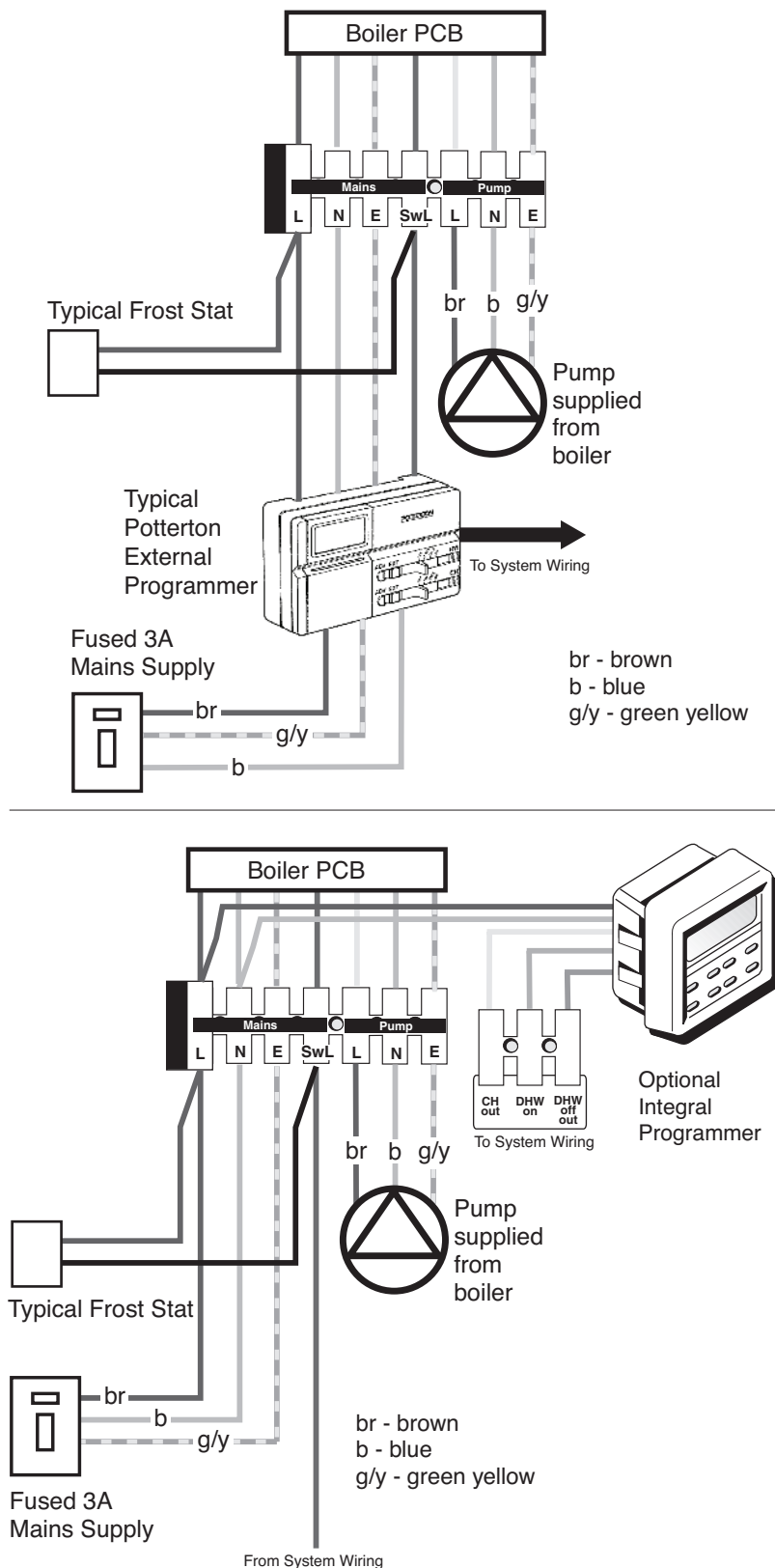

Fig. 35

4.3 Electrical Connections

For the boiler to operate correctly it requires a four wire connection. There must be mains Permanent Live, Neutral, Earth and a Switched Live from the system.

For the pump to operate correctly it must be wired back to the 'Pump' section of the boiler terminal block.

Ensure that the length of the earth wires are such, that if the supply cables are pulled out of the cable clamps the live and neutral wires become taut before the earth wire.

1. Remove the securing screw and pull the wiring centre (See Fig. 1) fully forward.

The wiring must be routed through the cable clamp.

Connect the power supplies as follows;

Permanent Live to 'Mains L'.
Neutral to 'Mains N'.
Earth to 'Mains E'.
Switched Live (from system) to 'SwL'

Pump Live to 'Pump L'
Pump Neutral to 'Pump N'
Pump Earth to 'Pump E'

2. If fitting a frost thermostat do so as described in the kit.
3. If fitting the optional integral programmer (Part No. 5111963) do so as described in the kit.
4. Carry out preliminary electrical system checks i.e. Earth Continuity, Short Circuit, Polarity and Resistance to Earth.

For safety, leave the electrical supply switched off and isolated until boiler installation is complete.

See Page 31 for typical system wiring.

4.4 Connect the Gas Supply

1. Ensure that the gas supply is isolated at the meter.
2. Solder the gas tail (supplied) to main gas supply before connecting the tail to the gas cock.

To prevent blow lamp damage to the wiring and condensate trap, any soldering of gas pipework must be done away from the boiler.

Do not turn the gas supply on until soundness test and boiler installation are complete.

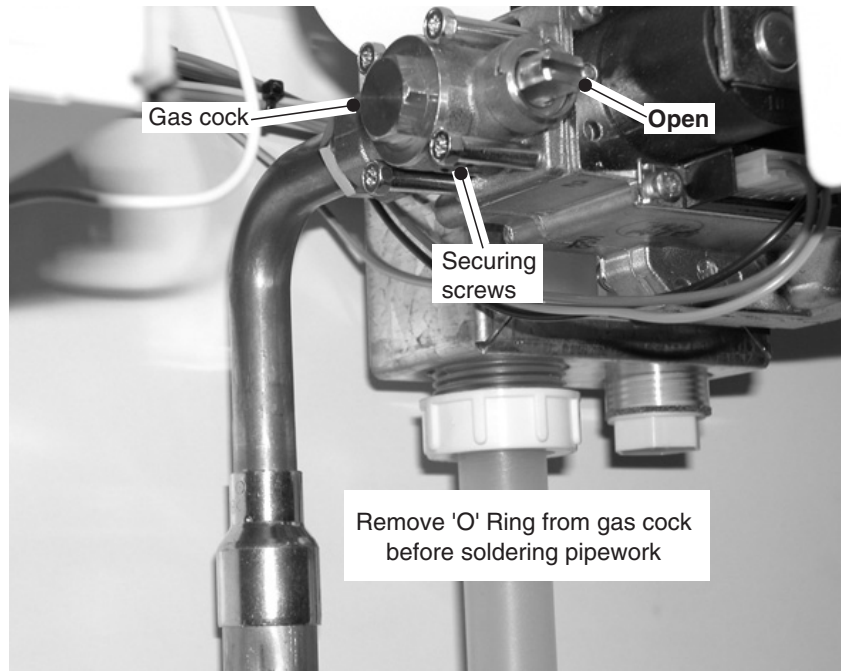

Fig. 36

4.5 Connect the Water System

1. Connect system pipework to the boiler.

Compression fittings must be used to allow future disconnection.

We recommend using two spanners when making the connections.

Heat from a blowlamp could damage the case seals.

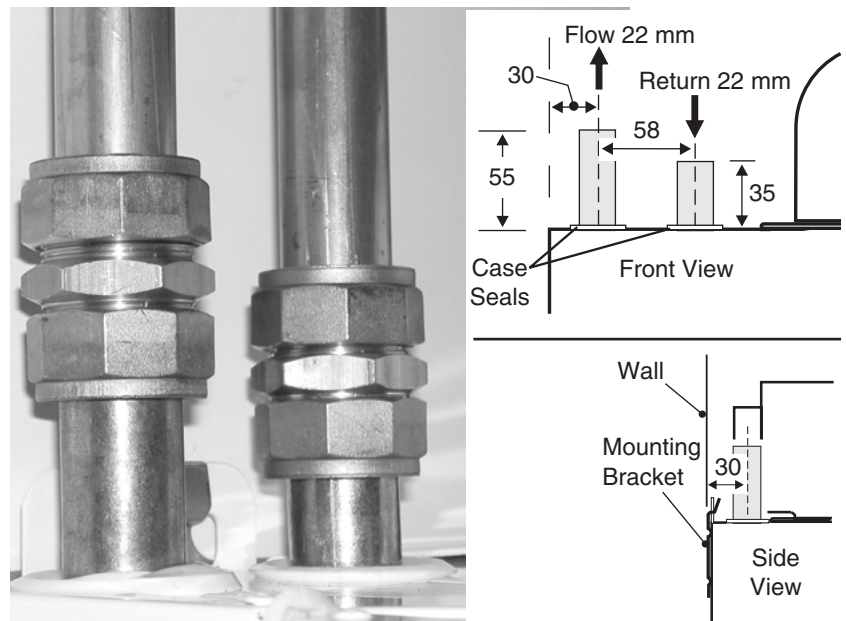

Fig. 37

4.6 Connect the Condensate System

1. The condensate connection is a 21.5 mm PP pipe. To allow access for servicing, we recommend the first connection to the system is a 'push fit' type.
2. Prime the condensate system to seal the trap.

Method 1 - Pour 1/2 litre of water down through the flue products (inner) tube at the terminal.

Method 2 - Pour 1/2 litre of water via a plastic tube inserted into one of the flue sample points on the flue elbow.

3. Check the the condensate disposal system for soundness.

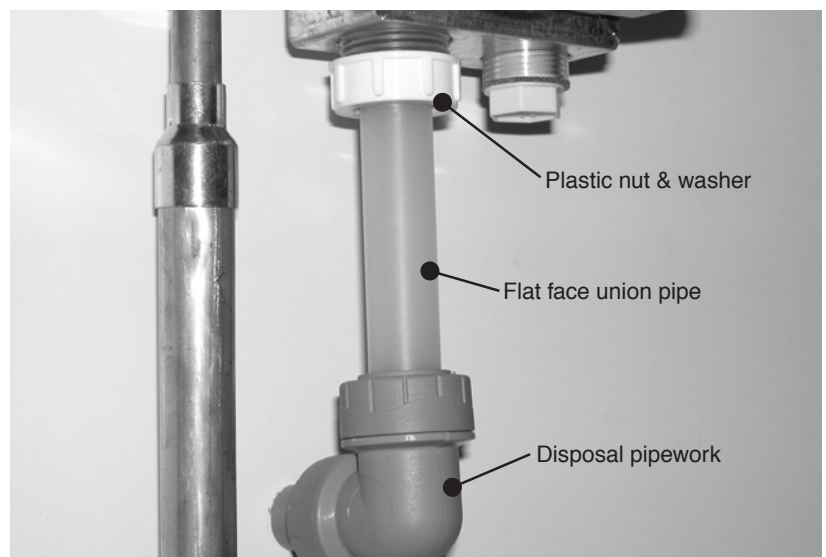

Fig. 38

5. Wiring Diagrams

Boiler Wiring

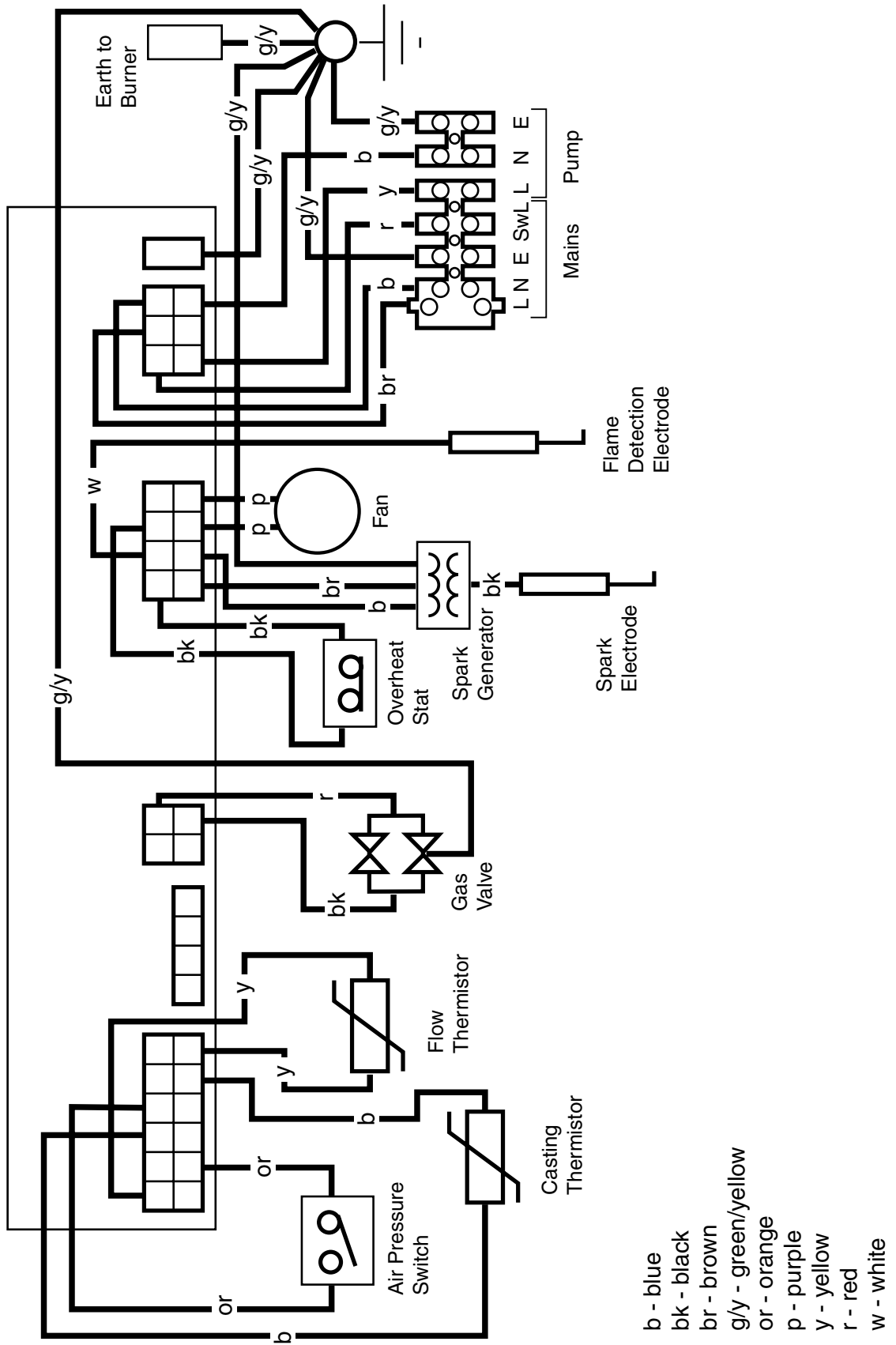

Fig. 39

6. Commissioning

6.1 Commission the Water, Electrical and Gas Systems

Water

The system should be cold flushed. After re-filling, all air must be vented from the system before the boiler is commissioned.

On Sealed Systems, manually test the safety valve and fill until the pressure gauge registers 1.5 bar.

Electrical

Ensure that the preliminary electrical safety checks detailed on Page 28 have been carried out.

Gas

The whole of the gas installation including the meter must be checked for soundness and purged according to in GB BS 6891 and in IE I.S. 813 "Domestic Gas Installations".

6.2 Commission the Boiler

Ensure the top cover and door are correctly fitted.

1. Ensure that the main electricity supply is 'On', the 'Mains On' (Green) light will flash.
2. Ensure that the main gas supply is turned 'On' and that the boiler gas service cock is in the 'On' position.
3. Check that the programmer and any other external controls, if fitted, are in an 'On' position and calling for heat.
4. Turn the temperature control knob to its maximum setting, the 'Burner On' (Green) light will flash and after several seconds, the burner will light automatically.
5. When the burner flame has established, the 'Burner On' (Green) light will be on and flames will be visible through the sight glass.
6. With the burner running, check the boiler for gas soundness using leak detection fluid.
7. Check that the gas supply pressure, burner pressure and gas rate are correct. See data label or refer to Page 6.

If adjustment of the burner pressure is required follow Section 9.4.

8. Check that the burner flames are blue and stable.

9. Turn the temperature control knob to (●) position and check that the burner shuts down.
10. Remove the pressure gauge, re-fit the screws and check for gas soundness.
11. Re-fit the controls cover assembly and secure with the screws previously removed.

6.3 Flush the system

1. Drain the system whilst still hot.
2. Re-fill, vent the system, make a final check for water soundness and add a suitable inhibitor.
3. Complete any labels supplied with the inhibitor and attach to the boiler for future reference.
4. Set the system flow rate to give the required temperature rise. Set the bypass flow rate.
5. On sealed systems fill until the pressure gauge registers 1.5 bar. Set the pressure gauge pointer to the system design pressure.

If the boiler fails to light

After five attempts (possibly due to air in the gas supply) it will lockout and the 'Lockout' (Red) light will be on.

To reset - Turn the temperature control knob to (●) position. Wait until the 'Lockout' (Red) light switches off. Turn the temperature control knob back to the required setting. The boiler should reset and return to normal operation.

If the boiler fails to operate

Check for fault or lockout codes on the control display and refer to one or a combination of the following:- User Operating label on the boiler. Wiring Diagram, Control Sequence and Fault Finding sections in these instructions.

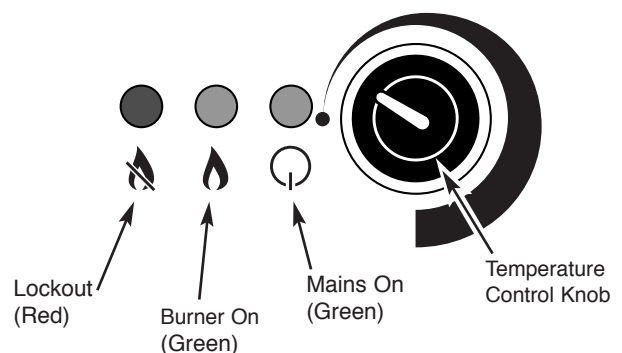

Fig. 41

6.4 Final Adjustments

Temperature Control

Turn the temperature control knob to adjust the radiator surface temperature and hot water tap temperature between approximately 63°C and 82°C.

Overheat Thermostat

The boiler will require re-setting if an overheat condition occurs (the 'Lockout' (Red) light will flash).

Other Boiler Controls

No further setting or checking is necessary as all boiler mounted controls are fail safe.

System Controls

Check that any other external controls connected in the system, such as thermostats are set as required. If a programmer is fitted, set the time and programme the required settings as shown in the instructions supplied with the programmer.

6.5 Advise the User

On completion of the installation, the installer should hand over all instructions and demonstrate the operation of the boiler and its associated controls.

Advise the user of the precautions necessary to prevent damage to the system and to the building in the event of the system remaining inoperative during frost conditions.

Advise the user that this boiler has frost protection, pump overrun and pump anti-seize features (See 3.9.4).

Advise the User that for continued efficient and safe operation of the boiler it is important that adequate servicing is carried out at least once a year.

6.6 Documentation

Carefully read and complete all sections of the "Benchmark" Commissioning Checklist at the rear of this publication that are relevant to the boiler and installation. The details will be required in the event of any warranty work. This publication must be handed to the user for safe keeping and each subsequent regular service visit recorded.

For IE, it is necessary to complete a "Declaration of Conformity" to indicate compliance to I.S. 813. An example of this is given in I.S. 813 "Domestic Gas Installations". This is in addition to the "Benchmark" Commissioning Checklist.

8. Fault Finding Guide

Lockout Codes

Key ○ = off ◻ = flashing ● = on



FAULT	CONTROL DISPLAY			RESET
				
	Lockout	Burner	Mains	
Electrical Supply Fault	○	○	○	
Ignition LOCKOUT	●	○	●	Manual
Overheat LOCKOUT	◻	○	●	Manual
False Flame Fault	◻	◻	◻	Automatic
Water Circulation LOCKOUT	●	◻	◻	Manual
PCB Fault (Replace PCB)	●	●	◻	Automatic
Air Proving LOCKOUT	●	○	○	Manual
APS Stuck Fault	◻	○	○	Automatic
Flow Thermistor Fault	●	◻	●	Automatic
Casting Thermistor Fault	◻	◻	○	Automatic

Fig. 43

Electrical Supply Fault

Refer to the boiler wiring diagram

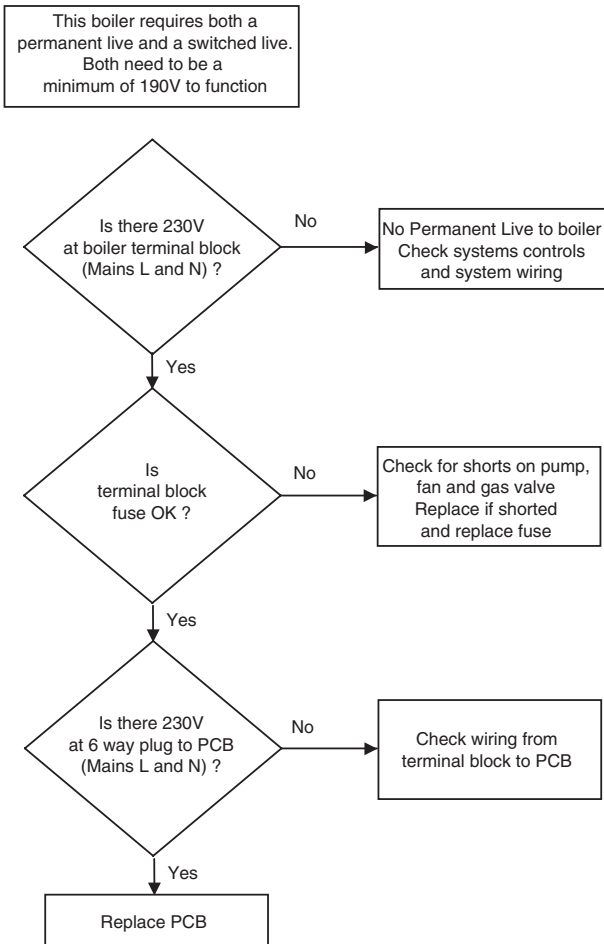
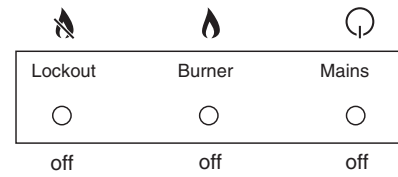

Fig. 44

Ignition Lockout

Refer to the boiler wiring diagram

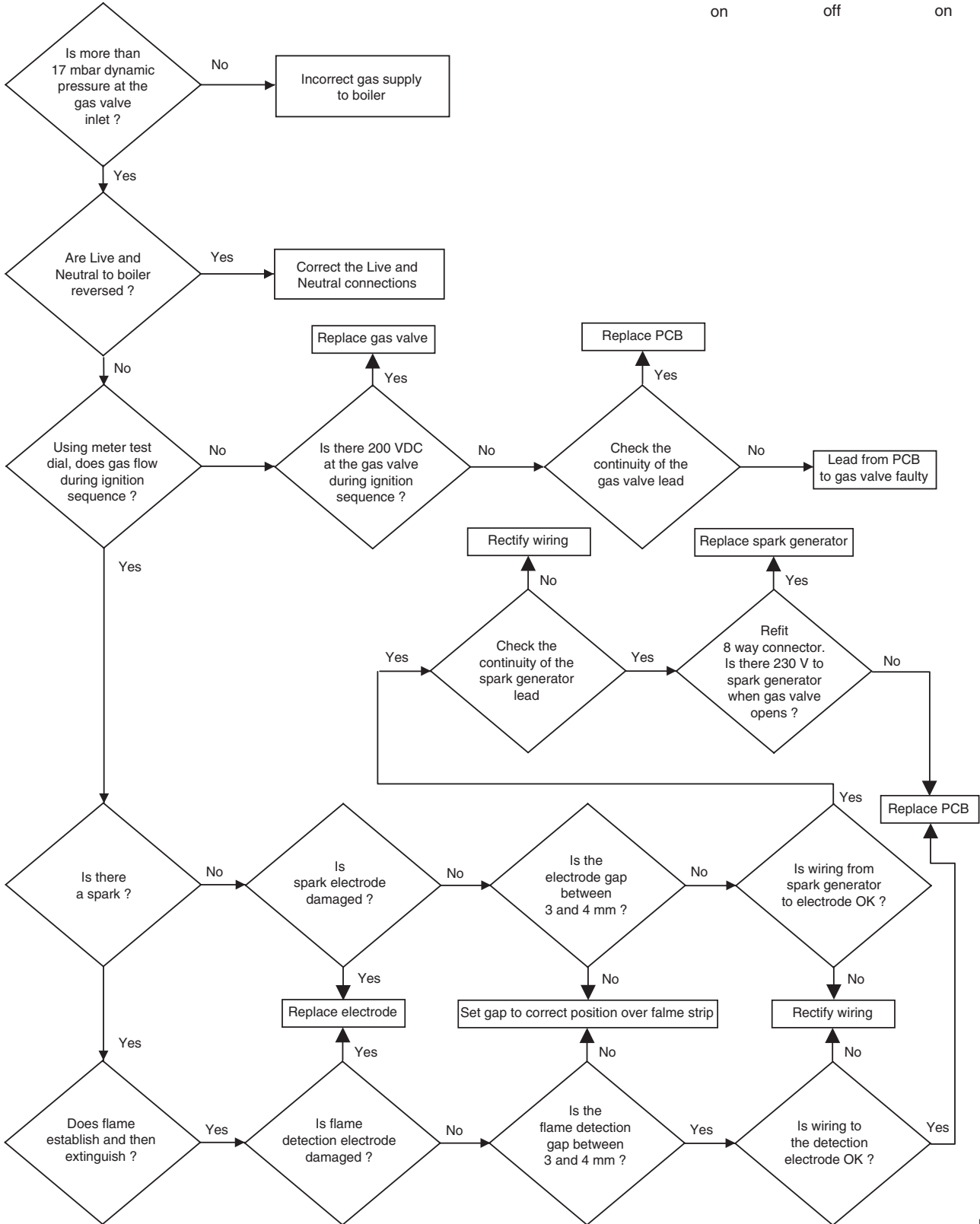
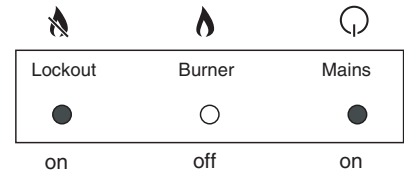
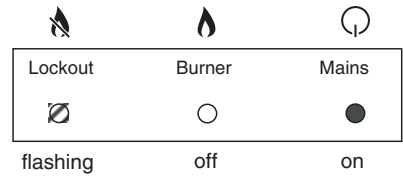
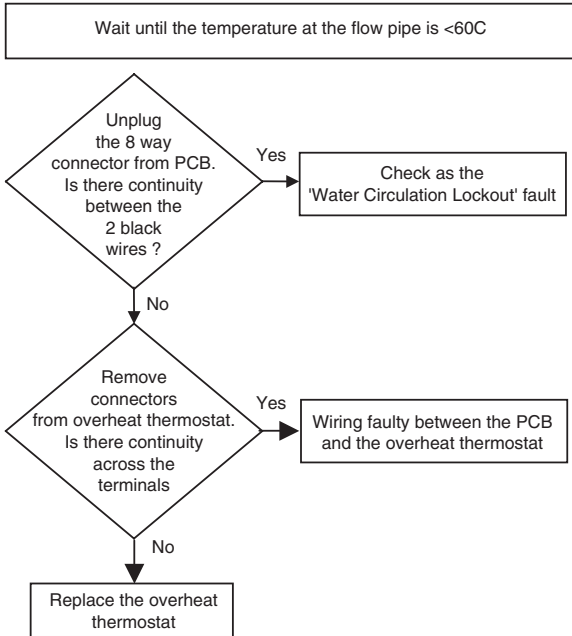

Fig. 45

Overheat Lockout

Refer to the boiler wiring diagram



False Flame Fault

Refer to the boiler wiring diagram

A check is made that no flame is present before an ignition attempt is made. The presence of flame is continually checked during the run period.
Note: An unstable flame will cause intermittent problems.

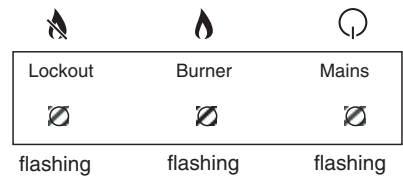
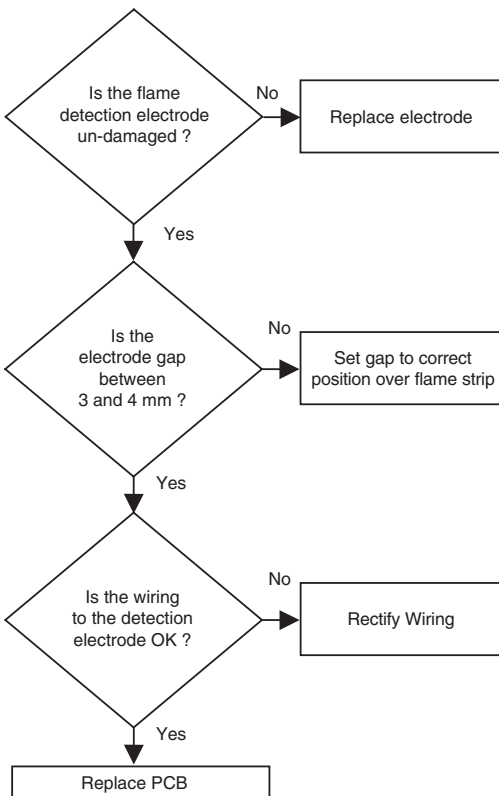

Fig. 46

Water Circulation Lockout

Refer to the boiler wiring diagram

This indication can be activated by two faults:

- 1) Flow direction is checked after 1 minute of burner fire. If the casting thermistor reads a higher temperature than the flow thermistor, the fault occurs. This does not cause a lockout.
- 2) Adequate circulation is checked continuously during burner fire. If the casting thermistor exceeds 80C the fault occurs. A lockout is activated if this happens 4 times.

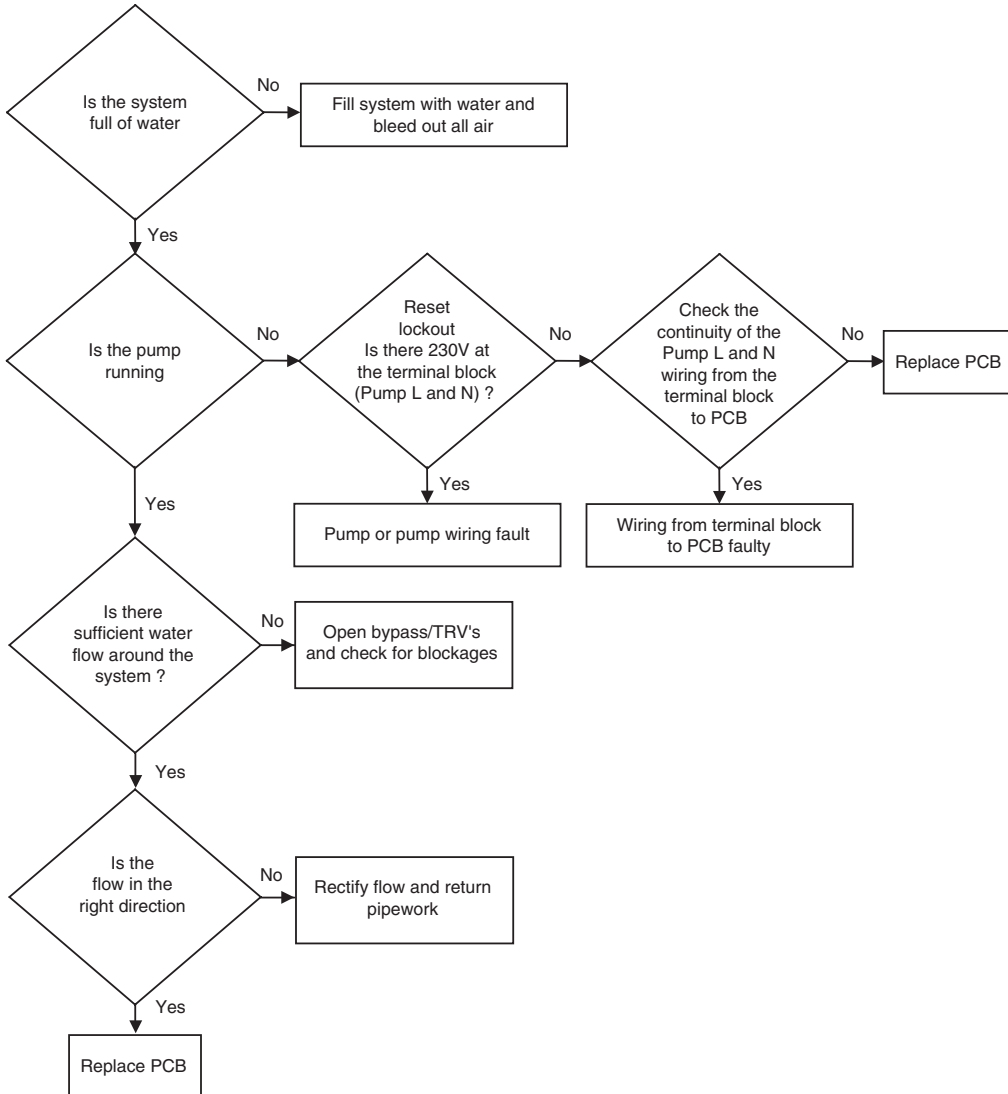
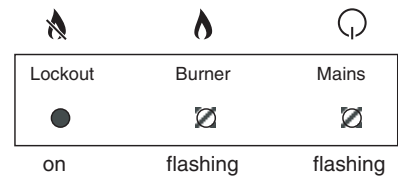

Air Proving Lockout

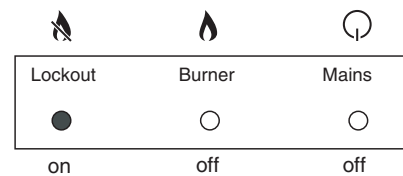







Fig. 47

Air Pressure Switch Stuck Fault

Refer to the boiler wiring diagram

		
Lockout	Burner	Mains
		
flashing	off	off

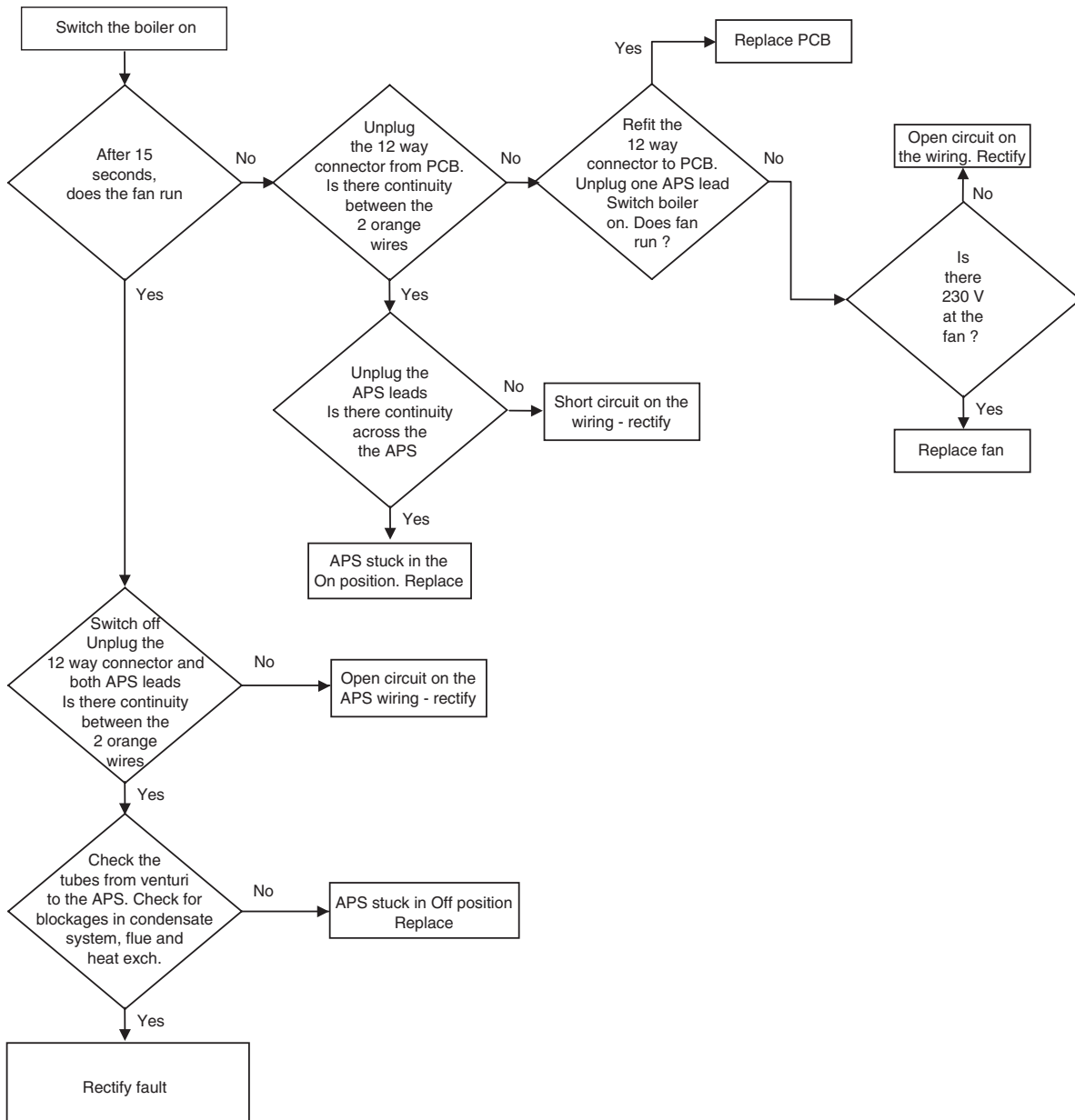

Fig. 48

Thermistor Fault - Flow and Casting

Refer to the boiler wiring diagram

There are two types of fault which can occur:
 1) The thermistors are reading outside of limits (this is checked before the PUMP is switched on and during Burner on).
 2) The difference between the thermistor readings are outside of limits (this is checked during PUMP on stage).

Check that the Pump is running and there is adequate circulation of water.

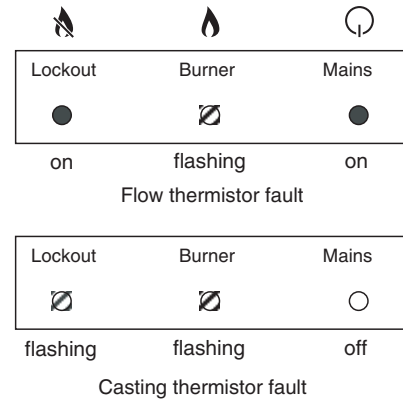
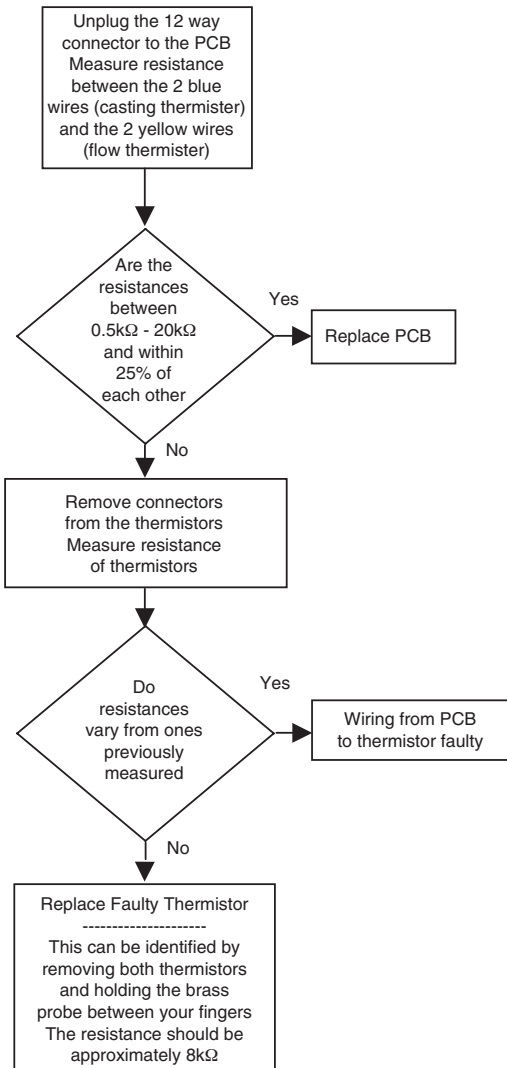

Fig. 49

9. Servicing

- For reasons of safety and economy the boiler should be serviced annually by a competent person.
- **Any 'O' rings, seals or gaskets disturbed during servicing or replacement of parts must be visually inspected and replaced if worn or damaged.**
- **Important: Always test for gas soundness after servicing or replacement of gas carrying components and carry out functional checks of controls.**
- Ensure you are using the correct Main approved spare part when replacing any items as incorrect or sub standard parts could affect the operation of the boiler.
- Some seals on this boiler are special 'wet' type designed for use with condensing boilers.

9.1 Servicing Procedure

1. With the outer case correctly fitted, fire the boiler and check that the flames visible through the sight glass are blue and stable. Yellow flame and excessive lifting indicate poor combustion.
2. Turn the temperature control knob to (●) position and check that the burner shuts off. Allow the boiler to cool and isolate the gas and electricity supplies.

The boiler cannot be isolated at the user interface. Isolate the electricity supply at the mains supply point.

Warning: The 24 model is fitted with a 325Vdc fan. Ensure the mains supply is isolated.

3. Pull the door panel down and remove the two screws. Carefully slide the bottom cover out and away from the boiler.
4. Remove the three screws and carefully lift the outer case away from the boiler.
5. Remove the combustion chamber cover - See 9.9.
6. Visually check for debris/damage and clean or replace if necessary the following.
 - a. Combustion Chamber Insulation - replace if required, see 9.12.
 - b. Fan - remove as shown in 9.9. Examine the fan impeller and carefully clean if necessary. Check the condition of the sensing tubes at the Fan and Air Pressure Switch.
 - c. Burner - remove if required, see 9.10. Brush the burner top and check that the flame ports are clear. Any blockage may be removed with a fine wire brush. Turn the burner upside down and tap gently to remove any debris (Protect the electrodes).
 - d. Electrodes - remove if required, see 9.10. If the electrodes require cleaning wipe the surface using a solvent.
 - e. Injector - remove if required, see 9.11. Omit this operation if the gas rate is correct, otherwise clean by blowing through. Do NOT clear the injector with a pin or wire.
 - f. Condensate trap - remove if required, see 9.13. Place a vessel underneath to catch the condensate then remove the trap drain plug. Take care as the condensate could be hot. Clear out any debris then re-prime the trap, see 4.6.
 - g. Primary heat exchanger - remove flue hood, see 9.9. Place a sheet of paper under the heat exchanger then using a flat blade tool (Part No. 907736), scrape the flueway fin surfaces in a downward movement. This will ensure that most of the deposits will be collected on the paper.
 - h. Secondary heat exchanger - remove the hood and sump as shown in 9.15 and clean as required.
 - j. Check the condition of all electrical cables and connectors.
 - k. On re-assembly ensure that the outer white case is correctly fitted and that the sealing strip fitted to the door is forming a tight seal with the boiler casing.
7. Inspect the flue terminal for blockage and integrity, rectify if necessary.
8. Inspect the condensate disposal system for damage, rectify if necessary.
9. Carry out a functional test of the controls and check the gas rate.
10. Check the dilution of the system inhibitor and top up as required. Failure to check and correct inhibitor concentration may damage the heat exchanger.
11. Complete the relevant Service Interval Record section of the 'Benchmark' Commissioning Checklist at the rear of this publication.

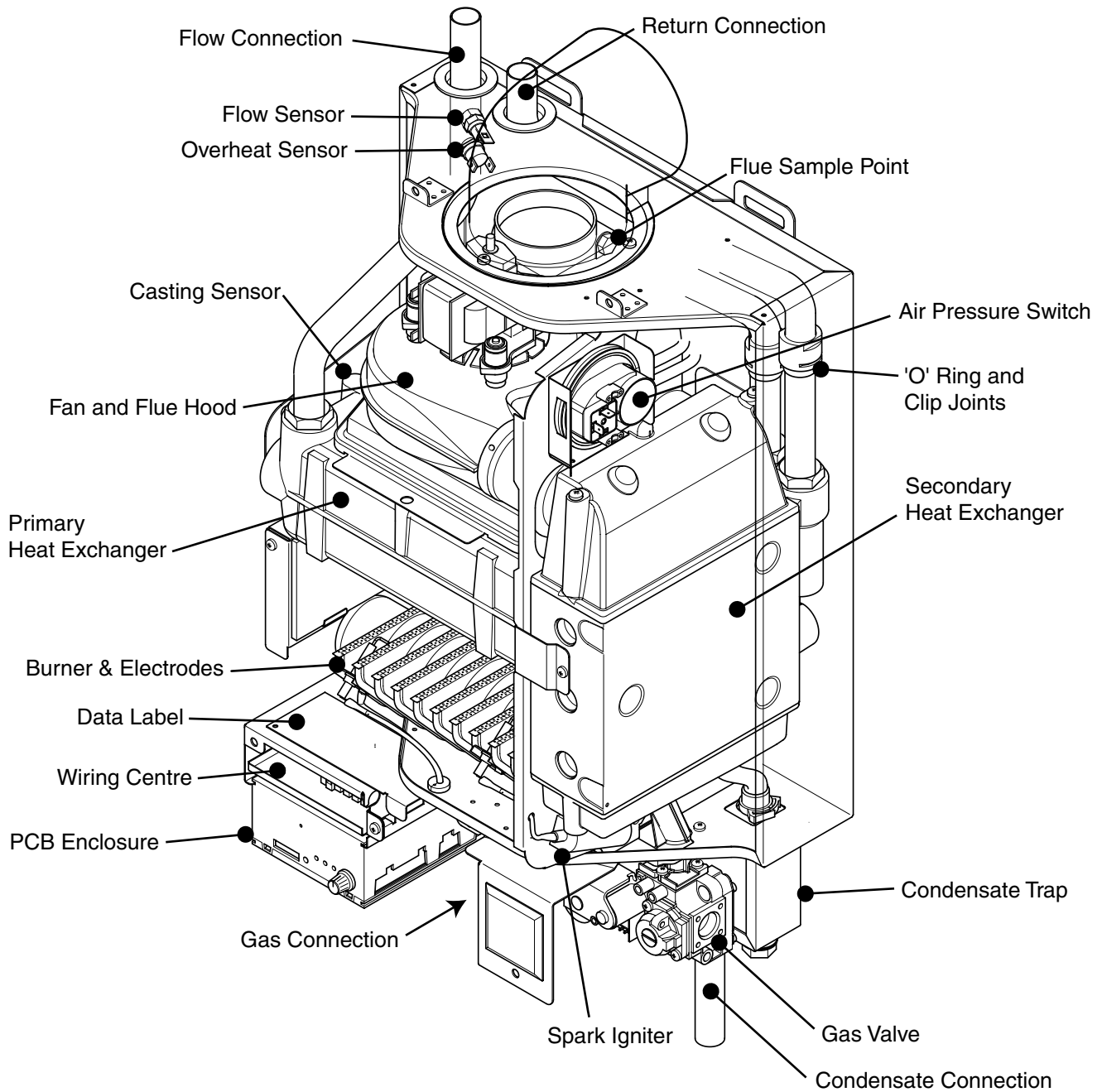
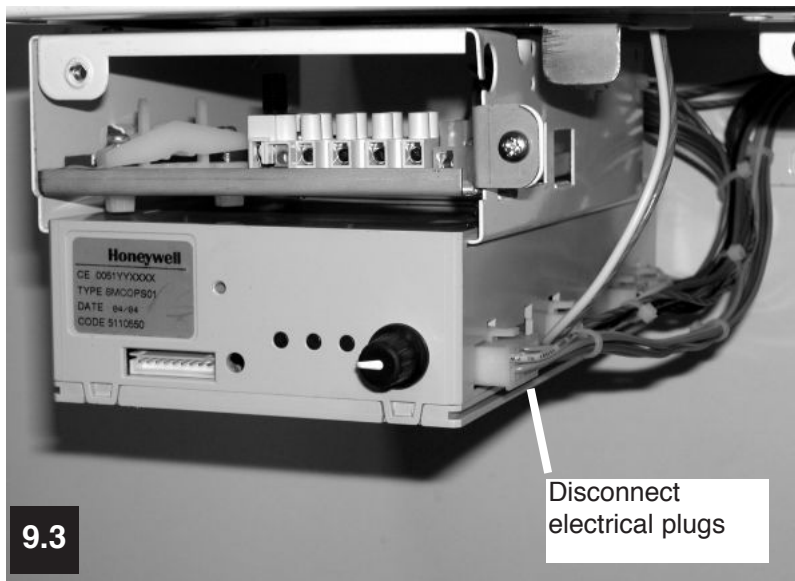

Fig. 50

9. Parts Replacement



9.2 General Access

1. Isolate the supplies as detailed in 9.1.2.
2. Pull the door panel down and remove the two screws. Carefully slide the bottom cover out and away from the boiler.
3. Remove the three screws and carefully lift the outer case away from the boiler.

9.3 PCB Enclosure

1. Perform General Access - See 9.2. Removal of the outer case is not necessary.
2. Disconnect all electrical plugs and slide the enclosure out of its frame.
3. On re-assembly refer to the wiring diagram when re-connecting electrical plugs.

Fig. 51

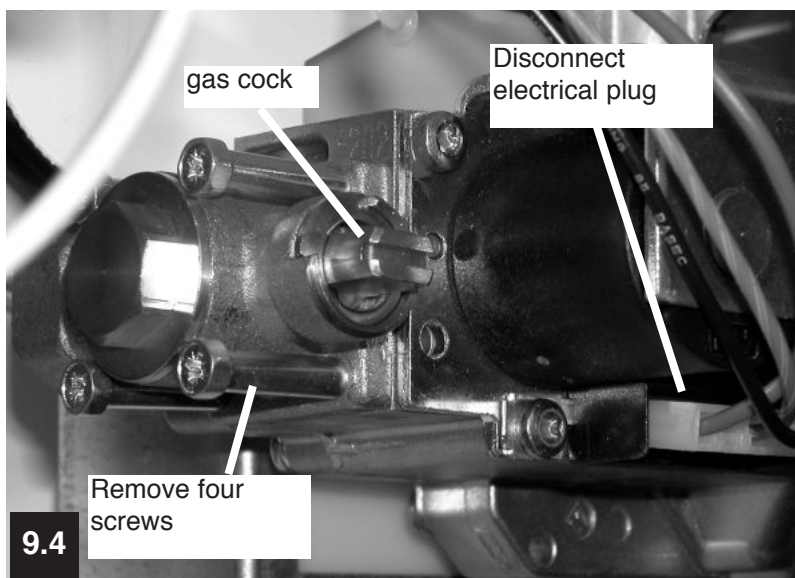

9.4 Gas Valve

1. Perform General Access - See 9.2. Removal of the outer case is not necessary.
2. Note how it fits then disconnect the electrical plug from the gas valve.
3. Remove the gas cock by unscrewing the four long hexagonal head screws from the side of the valve.

Note: Loosen the condensate trap securing screws to improve access to the gas valve.

4. Using the service spanner supplied with the new valve, remove the front screw and loosen the two rear screws securing the gas valve to the manifold.
5. Slide the valve backwards and carefully remove from the boiler.
6. Re-assemble in reverse order using a new 'O' ring. Remember to re-tighten the condensate trap and ensure the electrical plug to the gas valve is in the correct orientation.
7. Check the burner pressure (see data label for pressures). If adjustment is required, turn pressure adjusting screw anti-clockwise to increase pressure or clockwise to decrease.

Fig. 52

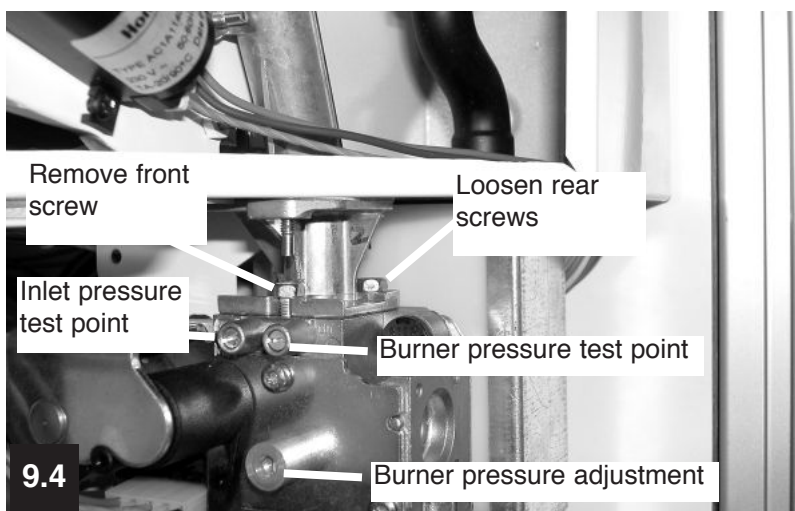

Fig. 53

9.5 Air Pressure Switch

1. Perform General Access - See 9.2.
2. Disconnect the wires at the switch.
3. Note how they are fitted then disconnect the sensing tubes at the switch.
4. Ease the front of the bracket forwards and carefully prise the switch out of the bracket. If the bracket is removed for any reason, note that the hole in the side face locates around a rivet head.
5. Re-assemble in reverse order, polarity is not important when connecting the wires.
The coloured sensing tube fits to the outer of the two connections.

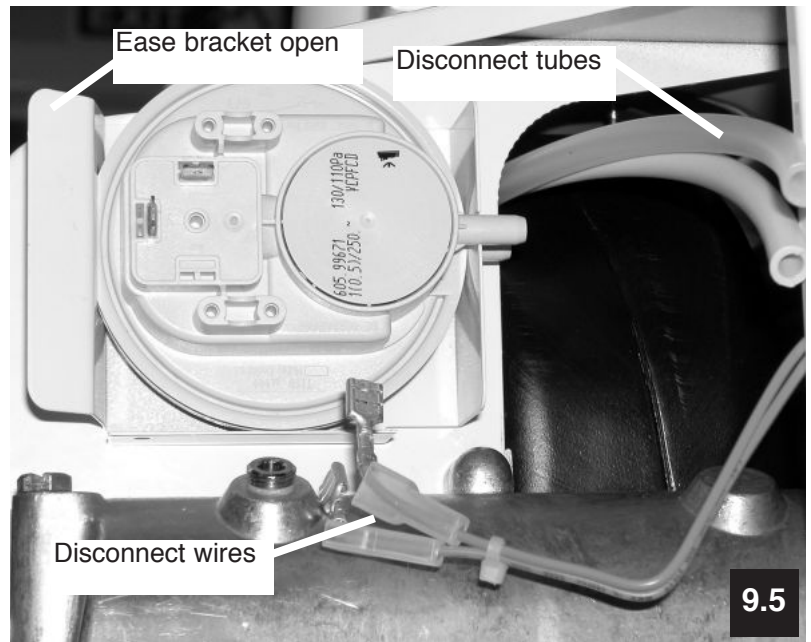

Fig. 54

9.6 Spark Igniter

1. Perform General Access - See 9.2.
2. Disconnect ignition lead at the ignition electrode.
3. Loosen securing screws, slide unit back to clear screws and lift away from the boiler.
4. Disconnect the electrical plug. Disconnect ignition lead if required.
4. Re-assemble in reverse order.

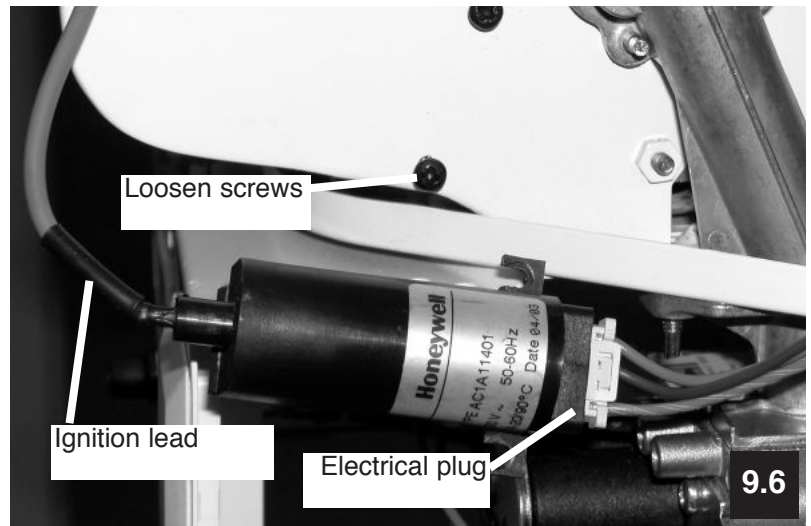

Fig. 55

9.7 Flow & Casting Sensors

1. Perform General Access - See 9.2.
2. Disconnect the electrical plug from the sensor and unscrew the sensor from the pocket.
3. Re-assemble in reverse order. Use a heat sink compound on the sensor shaft, insert and tighten to finger tight and a quarter turn.

9.8 Overheat Sensor

1. Perform General Access - See 9.2.
2. Disconnect the spade connectors from the sensor and unscrew the sensor from the pipe.
3. Re-assemble in reverse order, polarity is not important when connecting the wires. Insert and tighten to finger tight and a quarter turn.

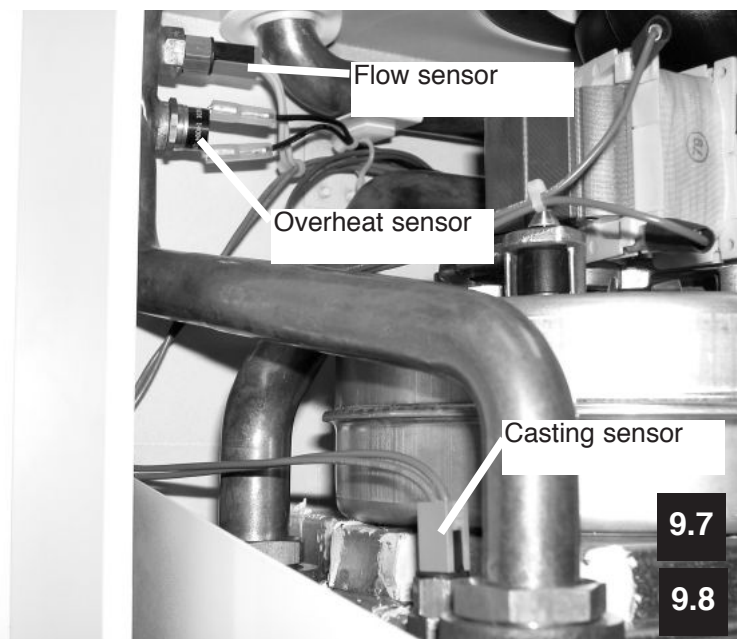

Fig. 56

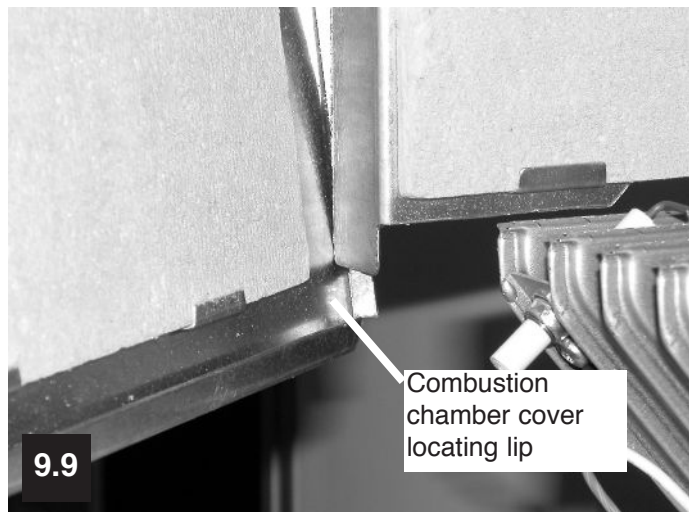
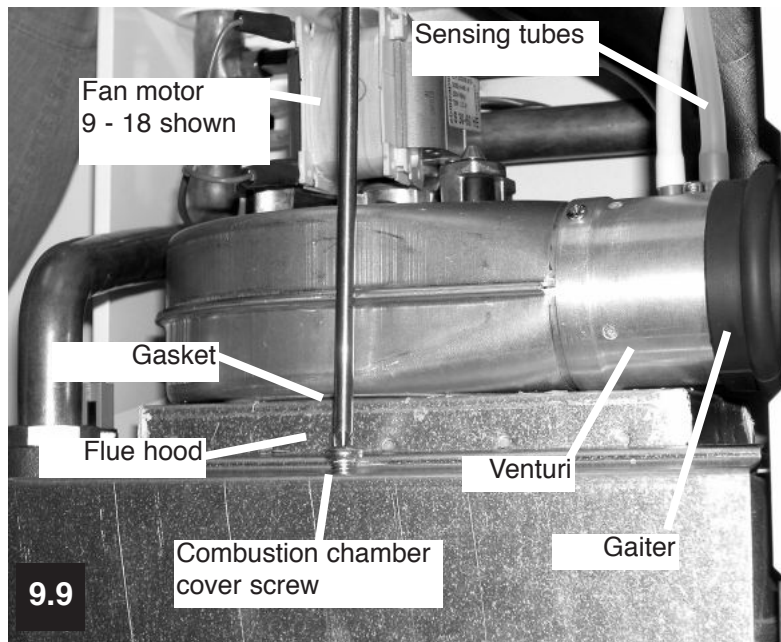

Fig. 57

9.9 Fan and Flue Hood

a.c fan - 9 to 18 models

d.c. fan - 24 model

1. Perform General Access - See 9.2.
2. Remove the screw securing the front combustion chamber cover. Pull the cover out slightly then down to unhook and lift away from the boiler.
3. Note how they are fitted then disconnect the sensing tubes from the venturi.
4. Disconnect the electrical spade connectors from the fan motor (9 to 18) or electrical plugs (24).
5. Roll the gaiter away from the venturi towards the secondary heat exchanger.
6. Slide the fan and flue hood forwards and away from the boiler.
7. Remove the four screws securing the fan to the flue hood and the screw securing the venturi to the fan.
8. On re-assembly:-

Remove all traces of gasket from the flue hood then attach new gasket. Fit the fan to the flue hood and secure using four screws previously removed. Fit the venturi assembly to the replacement fan.

Ensure that the flue hood locates under the clips at the rear of the chassis. The front of the flue hood will rise slightly under the pressure of the clips.

Re-assemble all remaining parts in reverse order. Polarity is not important when re-connecting a.c. fan wires.

Ensure the sensing tubes are fitted correctly, **the coloured tube will be nearest to the fan.**

9.10 Electrodes/Burner

1. Perform General Access - See 9.2.
2. Remove the combustion chamber cover - See 9.9.
3. Disconnect the ignition lead from the ignition electrode and the sensing lead and earth lead from the sensing electrode.

If replacing electrode(s), remove securing screw(s) as appropriate.

4. Remove the securing screw at the right hand side, hold the burner, apply greater pressure at the right hand side and pull to disconnect from the spring clips on the support bracket.
5. Transfer electrodes onto replacement burner before re-fitting.
6. Re-assemble in reverse order.

Check that the gap between the electrode tip and the burner face is 3 - 4 mm, adjustment can be made by careful use of pliers.

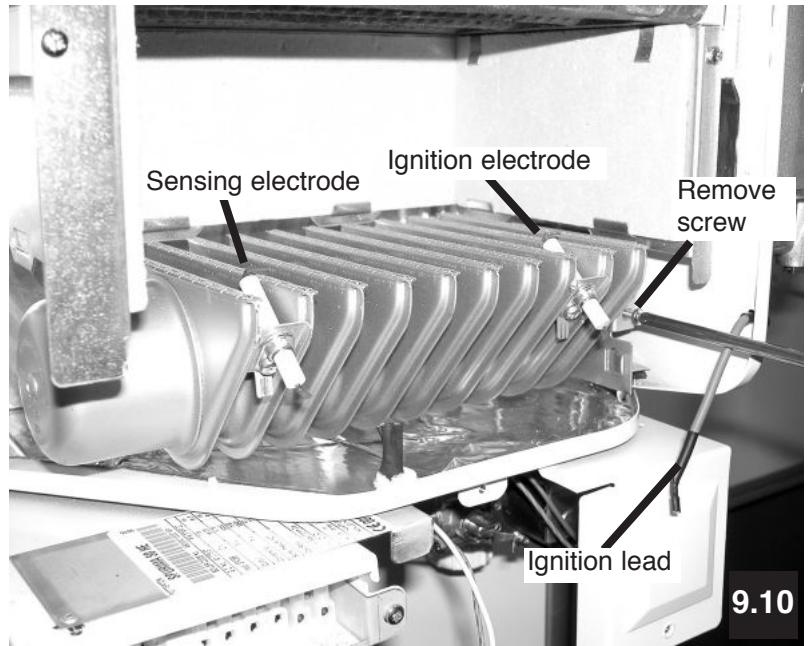

Ensure electrodes are sat over flame ports as shown and have 3 - 4 mm gaps between tip and burner face.

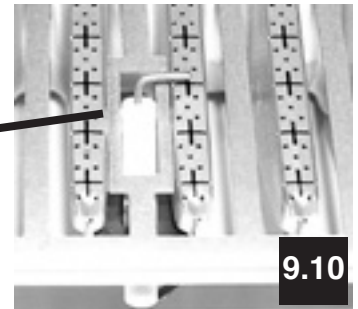

Fig. 58

9.11 Injector

1. Remove the Burner - See 9.10

Use a 13 mm (A/F) or 1/2" (A/F) socket spanner to remove the injector.

2. Unscrew the injector.
3. Re-assemble in reverse order. Use a new sealing washer on the injector and test for gas soundness.

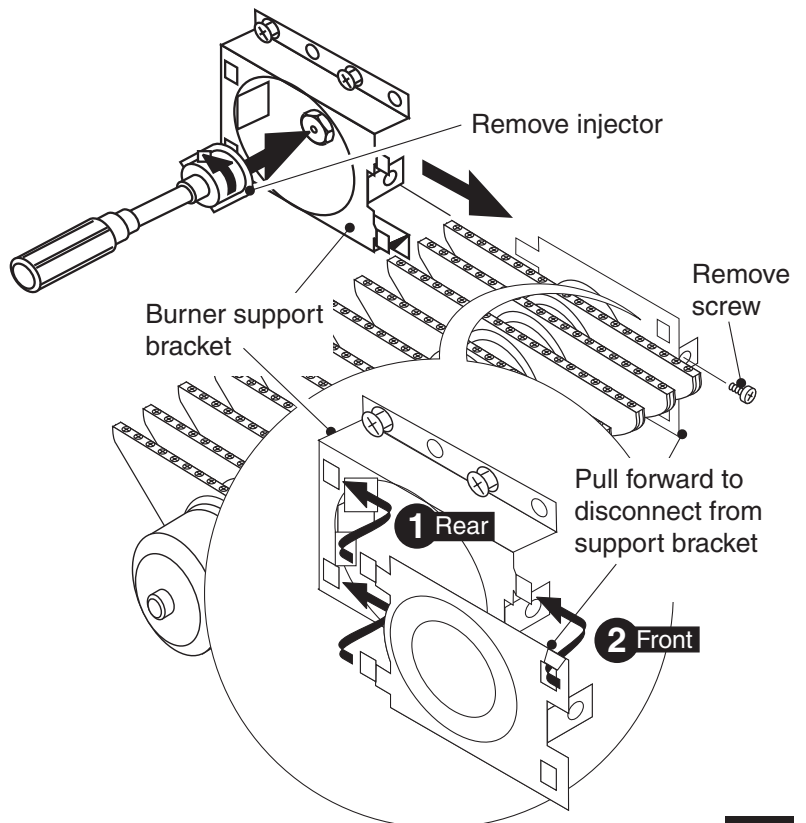
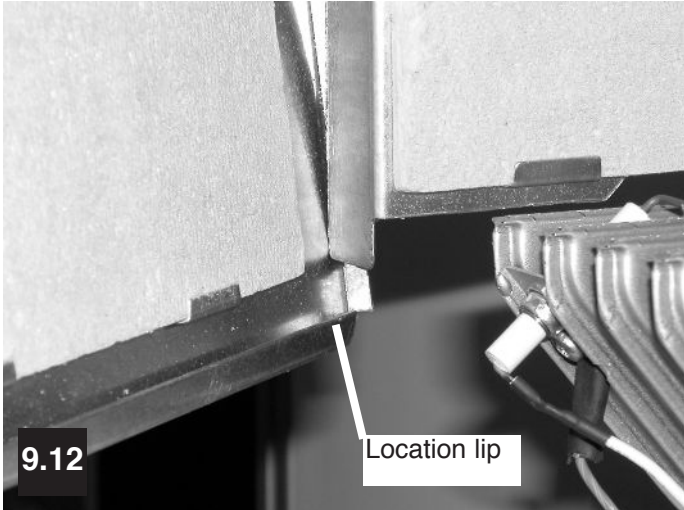

Fig. 59



9.12 Combustion Chamber Insulation

Important: See Section 3.1, Health and Safety information before handling insulation.

1. Perform General Access - See 9.2.
2. Remove the screw securing the front combustion chamber cover. Pull the cover out slightly then down to unhook and lift away from the boiler.
3. Remove the Burner - See 9.10.
4. Remove the two screws securing the side and rear insulation assembly to the front of the chassis.
5. Pull the assembly forwards and away from the boiler. Replace insulation pieces as required, replace any securing clip if damaged.
6. Re-assemble in reverse order, ensure the insulation assembly has located correctly over the tabs at the rear of the casing below the casting and is NOT hanging down.

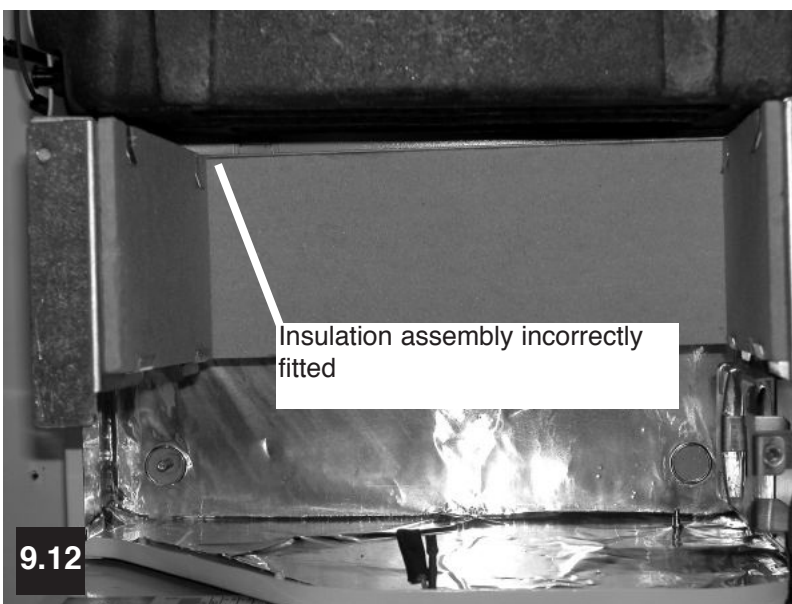
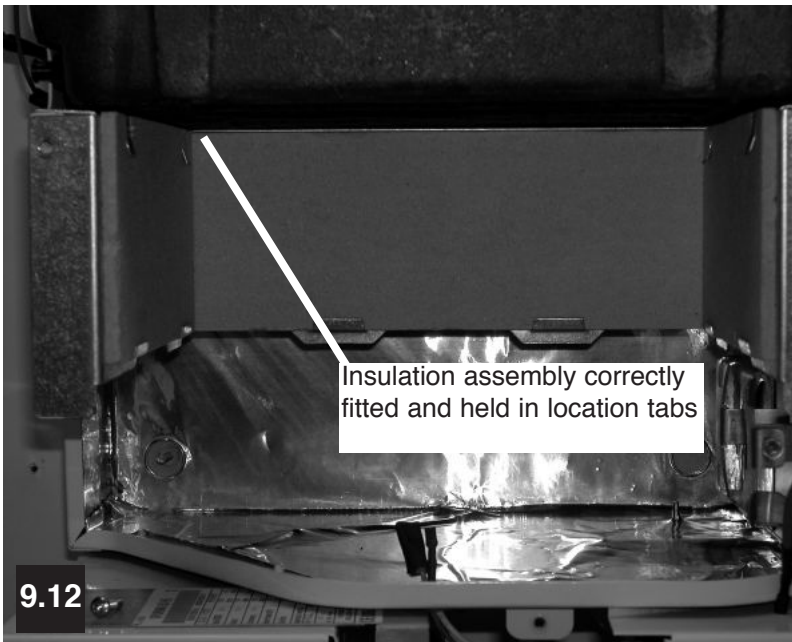

Fig. 60

9.13 Condensate Trap

1. Perform General Access - See 9.2.

Place a vessel underneath to catch the condensate then remove the drain plug. Take care as the condensate could be hot.

2. Disconnect condensate disposal pipework from the flat faced union on the trap and swing pipework away from boiler.
3. Release the spring clip securing the rubber tube to the base of the sump.
4. Loosen the left hand and remove the right hand screw securing the trap to the boiler.
5. Slide the trap to the right to release from the left hand screw then pull the unit (complete with tube) down and away from the boiler.
6. Re-assemble in reverse order using a new case seal.

Pour half a litre of water into the trap to prime it before re-fitting.

Ensure the tube and spring clip locate correctly onto the sump.

7. Re-connect condensate disposal pipework.

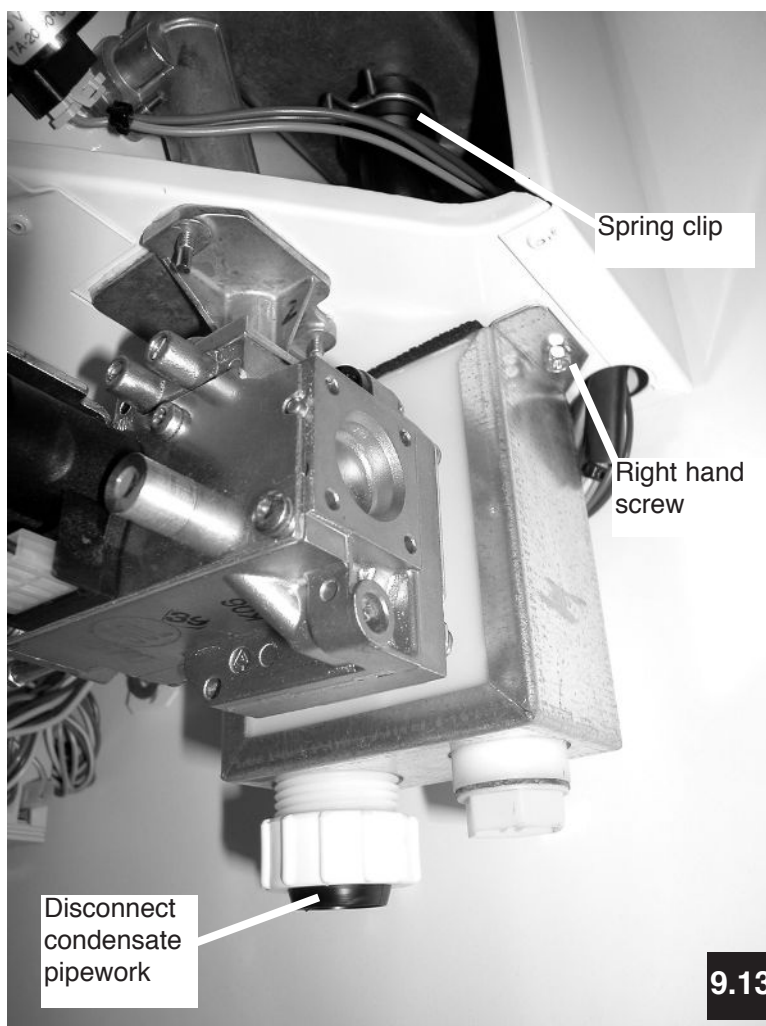

Fig. 61

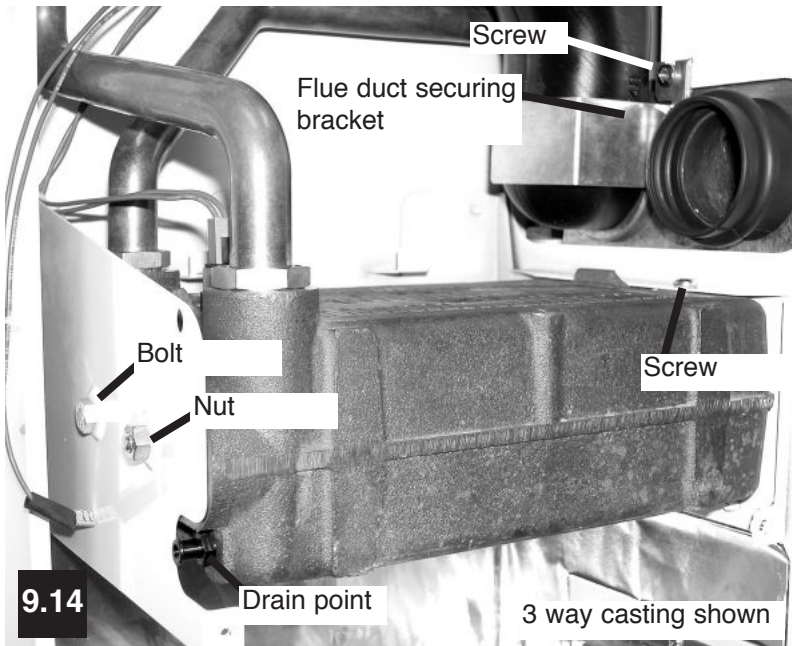

Fig. 62

9.14 Primary Heat Exchanger

1. Perform General Access - See 9.2.
 2. Drain the system as necessary.
 3. Remove the combustion chamber cover - See 9.9.
 4. Drain the heat exchanger, a drain point is located on the left hand side bottom of the heat exchanger. Attach a tube to the drain point, turn anti-clockwise to open and drain water away from the electronics.
 5. Remove the Casting Sensor - See 9.7.
 6. Remove the Fan and Flue Hood - See 9.9.
 7. Remove the Burner - See 9.10.
 8. Remove the Combustion Chamber Insulation - See 9.12.
- To ease the removal of the primary heat exchanger it may be necessary to:-
- Release the flow pipe compression fitting above the boiler.
 - Remove the clip securing the return pipe from the secondary to the primary heat exchanger.
9. Release the flow and return unions at the heat exchanger and lift the pipes clear.
 10. Remove the screw from the top right hand side and bolt and nut from the left hand side mounting brackets.
 11. Support the heat exchanger, spring out the left hand mounting bracket to clear the stud and withdraw the heat exchanger.
 12. Re-assemble in reverse order. Ensure all seals are replaced as necessary.
 - Ensure the return pipe is fully engaged and re-insert the pipe clip to lock it in position. Check the joint will not pull apart.
 13. Check the inhibitor concentration when re-commissioning the system.
 14. Vent all air from boiler and system before firing boiler.

9.15 Secondary Heat Exchanger

1. Perform General Access - See 9.2.
2. Drain the system as necessary.
3. Drain the Heat Exchanger - See 9.14, 4.
4. Remove the Spark Igniter - See 9.6.

To ease removal of the secondary heat exchanger it may be necessary to:-

- Remove the Air Pressure Switch - See 9.5.
 - Remove the air pressure switch mounting bracket.
 - Remove the Fan and Flue Hood - See 9.9.
 - Disconnect secondary to primary heat exchanger return pipe.
5. Remove the screw securing the flue duct mounting bracket to the inner case and remove the bracket - See Fig. 42.
 6. Remove the two pipe clips securing the flow and return pipes to the secondary heat exchanger.
 7. Remove the Condensate Trap - See 9.13. This will allow access through the hole in the case to the rear sump screw.
 8. Loosen the rear and remove the front sump screws. Carefully slide the sump forwards to remove from boiler.
 9. Support the heat exchanger then remove the screw and front supporting bracket.
 10. Manoeuvre the heat exchanger out to disconnect the gaiter and flue duct from the hood, pull down to release the pipe 'O' ring connections and lift away from the boiler.
 11. Check and replace seals, washers, 'O' rings etc as necessary. Lubricate 'O' rings prior to fitting.
 12. Re-assemble as follows:-
 - Align the flow and return pipes, lift the heat exchanger slightly to engage the 'O' ring joints and locate onto the rear case mounting bracket.
 - Re-fit the front mounting bracket and screw.
 - Ensure the flow and return pipes are fully engaged and re-insert the pipe clips to lock them in position. Check the joints will not pull apart.
 - Re-connect the secondary to primary heat exchanger return pipe.

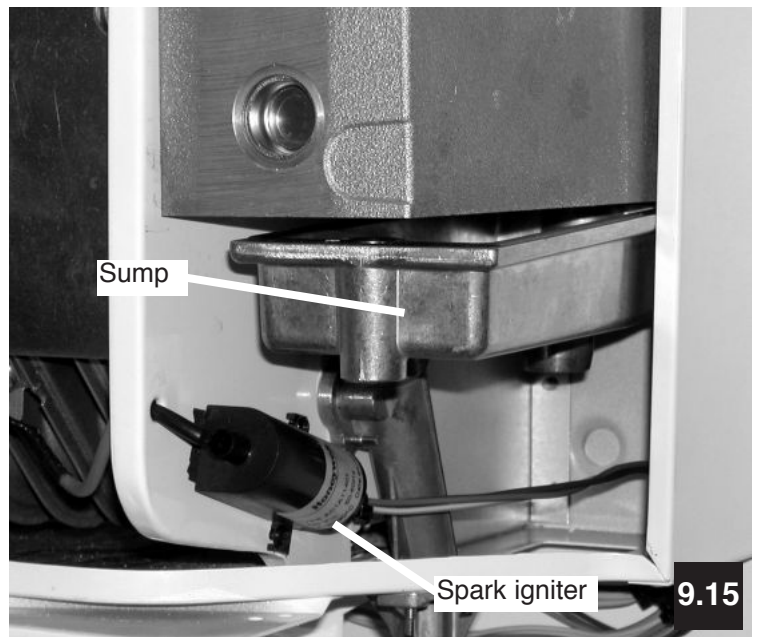
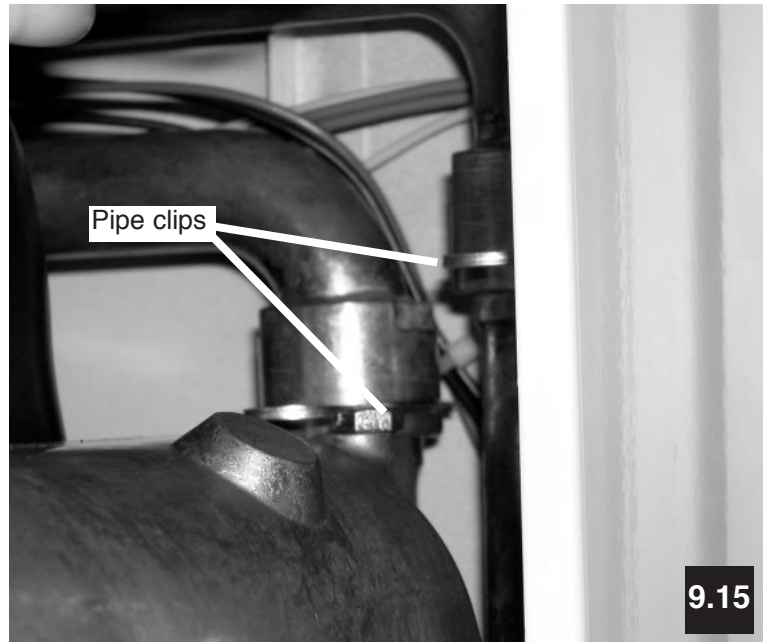

- Re-fit the sump.
- Re-fit the flue duct mounting bracket and screw.
- Re-assemble all remaining parts in reverse order.

13. Check the inhibitor concentration when re-commissioning the system.
14. Vent all air from boiler and system before firing boiler.

Fig. 63

10. Short Spares

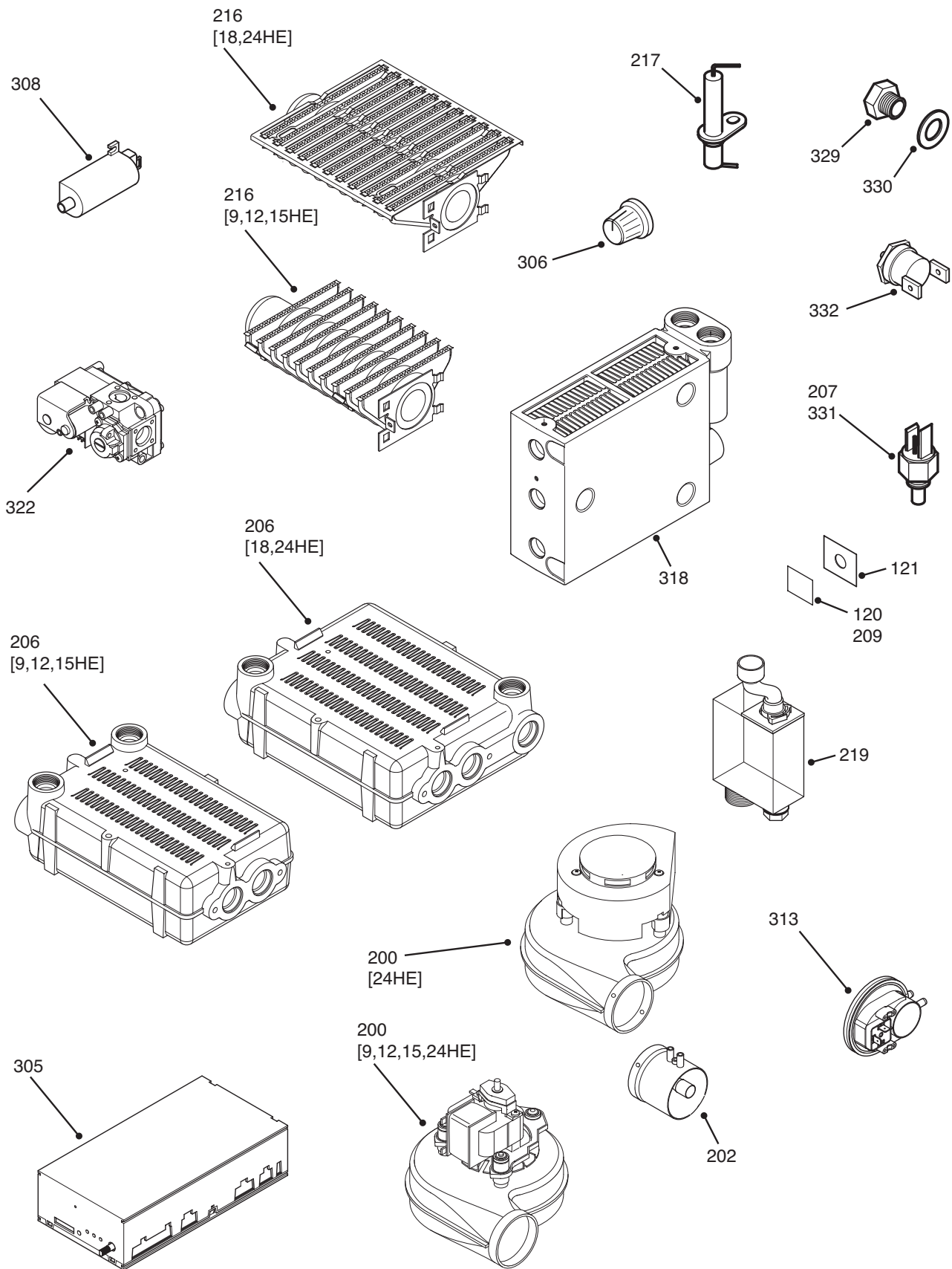

Fig. 64

Drg. Ref.	G.C. No.	Description	Qty	Part No.
120	114-852	Sight glass mica	1	238162
121	114-872	Mica retainer outer	1	238106
200		Fan and gasket kit 9 HE	1	5112318
		Fan and gasket kit 12 HE	1	5112319
		Fan and gasket kit 15 & 18 HE	1	5112320
		Fan and gasket kit 24 HE	1	5112321
202		Venturi assembly 9 & 12 HE	1	5112322
		Venturi assembly 15 HE	1	5112323
		Venturi assembly 18 HE	1	5112324
		Venturi assembly 24 HE	1	5112326
206		Heat exchanger - 3 way - primary	1	5113375
		Heat exchanger - 4 way - primary	1	5113376
207		Temperature sensor	1	5113044
209	114-852	Sight glass mica	1	238162
216	114-854	Burner sub-assembly 9,12,15 HE	1	238244
	114-856	Burner sub-assembly 18,24 HE	1	238246
217	E78-614	Electrode	2	407776
219		Condensate trap assembly	1	5111451
305		PCB assembly	1	5110550
306	364-866	Temperature control knob	1	230981
308		Igniter assembly	1	5111922
313		Air pressure switch 9 HE	1	5112195
		Air pressure switch 12 HE	1	5112196
		Air pressure switch 15 HE	1	5110350
		Air pressure switch 18 HE	1	5112197
		Air pressure switch 24 HE	1	5110393
318		Heat exchanger - secondary	1	5113517
322		Gas valve kit	1	5112334
329	173-133	Burner injector 9 HE 2.8 mm dia	1	411021
	173-134	Burner injector 12 HE 3.1 mm dia	1	411022
	173-135	Burner injector 15 HE 3.5 mm dia	1	411023
	173-137	Burner injector 18 HE 3.9 mm dia	1	411025
	173-138	Burner injector 24 HE 4.1 mm dia	1	411026
330		Washer - Injector	1	5112209
331		Temperature sensor	1	5113044
332	173-130	Overheat thermostat	1	404517

SERVICE RECORD

It is recommended that your heating system is serviced regularly and that the appropriate Service Record is completed.

Service Provider

Before completing the appropriate Service Record below, please ensure you have carried out the service as described in the manufacturer's instructions.

Always use the manufacturer's specified spare part when replacing controls.

SERVICE 1 Date

Energy Efficiency Checklist completed? Yes No

Engineer Name _____

Company Name _____

Telephone Number _____

Gas Safe Register licence No. _____

Comments _____

Signature _____

SERVICE 2 Date

Energy Efficiency Checklist completed? Yes No

Engineer Name _____

Company Name _____

Telephone Number _____

Gas Safe Register licence No. _____

Comments _____

Signature _____

SERVICE 3 Date

Energy Efficiency Checklist completed? Yes No

Engineer Name _____

Company Name _____

Telephone Number _____

Gas Safe Register licence No. _____

Comments _____

Signature _____

SERVICE 4 Date

Energy Efficiency Checklist completed? Yes No

Engineer Name _____

Company Name _____

Telephone Number _____

Gas Safe Register licence No. _____

Comments _____

Signature _____

SERVICE 5 Date

Energy Efficiency Checklist completed? Yes No

Engineer Name _____

Company Name _____

Telephone Number _____

Gas Safe Register licence No. _____

Comments _____

Signature _____

SERVICE 6 Date

Energy Efficiency Checklist completed? Yes No

Engineer Name _____

Company Name _____

Telephone Number _____

Gas Safe Register licence No. _____

Comments _____

Signature _____

SERVICE 7 Date

Energy Efficiency Checklist completed? Yes No

Engineer Name _____

Company Name _____

Telephone Number _____

Gas Safe Register licence No. _____

Comments _____

Signature _____

SERVICE 8 Date

Energy Efficiency Checklist completed? Yes No

Engineer Name _____

Company Name _____

Telephone Number _____

Gas Safe Register licence No. _____

Comments _____

Signature _____

SERVICE 9 Date

Energy Efficiency Checklist completed? Yes No

Engineer Name _____

Company Name _____

Telephone Number _____

Gas Safe Register licence No. _____

Comments _____

Signature _____

SERVICE 10 Date

Energy Efficiency Checklist completed? Yes No

Engineer Name _____

Company Name _____

Telephone Number _____

Gas Safe Register licence No. _____

Comments _____

Signature _____

All descriptions and illustrations provided in this leaflet have been carefully prepared but we reserve the right to make changes and improvements in our products which may affect the accuracy of the information contained in this leaflet. All goods are sold subject to our standard Conditions of Sale which are available on request.

MAIN

A Trading Division of Baxi Heating UK Ltd (3879156)

A Division of Baxi Group

Brooks House, Coventry Road, Warwick. CV34 4LL

After Sales Service 08701 655 644 Technical Enquiries 08706 049 049

Website www.mainheating.co.uk

e&oe

A BAXI GROUP company