

Installation and service instructions

for contractors

VIESMANN

Vitodens 242-F

Type FB2A

Compact Energy Tower with a gas condensing boiler

4.8 to 26 kW natural gas and LPG version

G.C. no: 47-819-18 (19 kW)

G.C. no: 47-819-19 (26kW)

For applicability, see the last page



VITODENS 242-F



Safety instructions



Please follow these safety instructions closely to prevent accidents and material losses.

Safety instructions explained



Danger

This symbol warns against the risk of injury.



Please note

This symbol warns against the risk of material losses and environmental pollution.

Note

Details identified by the word "Note" contain additional information.

Target group

These instructions are exclusively designed for qualified personnel.

- Work on gas equipment must only be carried out by a qualified gas fitter.
- Work on electrical equipment must only be carried out by a qualified electrician.
- The system must be commissioned by the system installer or a qualified person authorised by the installer.

Regulations

Observe the following when working on this system

- all legal instructions regarding the prevention of accidents,
- all legal instructions regarding environmental protection,
- the Code of Practice of relevant trade associations,

- all current safety regulations as defined by DIN, EN, DVGW, TRGI, TRF, VDE and all locally applicable standards,
- Gas Safety (Installation & Use) Regulations
 - the appropriate Building Regulation either the Building regulations, the Building Regulation (Scotland), Building Regulations (Northern Ireland),
 - the Water Fittings Regulation or Water Bylaws in Scotland,
 - the current I.E.E. Wiring Regulations.

If you smell gas



Danger

Escaping gas can lead to explosions which may result in serious injury.

- Never smoke. Prevent naked flames and sparks. Never switch lights or electrical appliances ON or OFF.
- Close the gas shut-off valve.
- Open windows and doors.
- Remove all people from the danger zone.
- Notify your gas or electricity supplier from outside the building.
- Shut off the electricity supply to the building from a safe place (outside the building).

Safety instructions (cont.)

If you smell flue gas



Danger

Flue gas can lead to life-threatening poisoning.

- Shut down the heating system.
- Ventilate the boiler room.
- Close all doors leading to the living space.

Working on the system

- When using gas as fuel, also close the main gas shut-off valve and safeguard against unauthorised reopening.
- Isolate the system from the power supply and check that it is no longer 'live', e.g. by removing a separate fuse or by means of a main isolator.
- Safeguard the system against unauthorised reconnection.



Please note

Electronic modules can be damaged by electro-static discharges.

Touch earthed objects, such as heating or water pipes, to discharge static loads.

Repair work



Please note

Repairing components which fulfil a safety function can compromise the safe operation of your heating system.

Replace faulty components only with original Viessmann spare parts.

Ancillary components, spare and wearing parts



Please note

Spare and wearing parts which have not been tested together with the heating system can compromise its function. Installing non-authorised components and non-approved modifications/conversion can compromise safety and may invalidate our warranty. For replacements, use only original spare parts from Viessmann or those which are approved by Viessmann.

Index

Installation instructions

Preparing for installation

Product information.....	6
Preparing for installation.....	6

Installation sequence

Installing the boiler.....	10
Opening the control unit casing.....	15
Electrical connections.....	16
Closing the control unit casing.....	20

Service instructions

Commissioning, inspection, maintenance

Steps - commissioning, inspection and maintenance.....	22
Further details regarding the individual steps.....	24

Code 1

Calling up code 1.....	61
General.....	61
Boiler.....	63
DHW.....	66
Solar.....	66
Heating circuit 1/heating circuit 2.....	67

Code 2

Calling up coding level 2.....	72
General.....	72
Boiler.....	74
DHW.....	75
Solar.....	76
Heating circuit 1/heating circuit 2.....	78

Diagnosis and service scans

Diagnosis.....	81
Checking outputs (relay test).....	83

Troubleshooting

Fault display.....	85
Fault codes.....	86
Repairs.....	93

Index (cont.)**Function description**

Internal extensions.....	108
External extensions (accessories).....	110
Control functions.....	112
Remote control DIP switches.....	118
Electronic combustion controller.....	119

Designs

Internal connection diagram.....	121
External connection diagram.....	122
Connection diagram solar control module.....	124

Parts lists	125
--------------------------	-----

Commissioning/service reports	135
--	-----

Specification	136
----------------------------	-----

Certificates

Declaration of conformity.....	137
Manufacturer's certificate according to the 1st BImSchV [Germany].....	138

Keyword index	139
----------------------------	-----

Product information

Vitodens 242-F, FB2A

Set up for operation with natural gas H.

For conversion to LPG P (without conversion kit), see page 30.

The Vitodens 242-F should generally only be delivered to those countries specified on the type plate. For deliveries to alternative countries, an approved contractor, on his own initiative, must arrange individual approval in accordance with the law of the land.

Preparing for installation

Transport

If possible, leave the boiler on the pallet during handling.

If space constraints make it necessary, the boiler can be split for handling.



Installation instructions provided



Please note

To prevent equipment damage, never set the boiler down on its front or side panels or apply loads to these areas.

Installation

Required room height: min. 2100 mm and the boiler weight is 161 (19kW) to 165kg (26kW) (dry).

Preparing the boiler installation

Use a connection set, available as an accessory, to make the connection on the gas and water sides. The following overview shows sample connection sets for installation on finished walls to the top or side.

Preparing the connections on site:



Connection set installation instructions.



Please note

To prevent equipment damage, install all pipework free of load and torque stresses.

Preparing for installation (cont.)

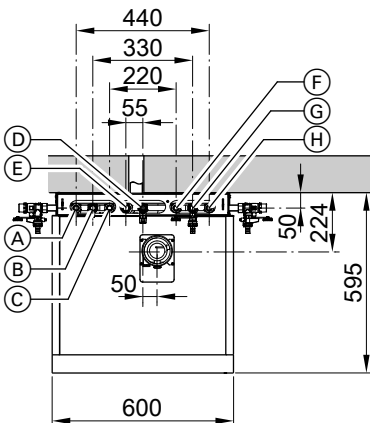
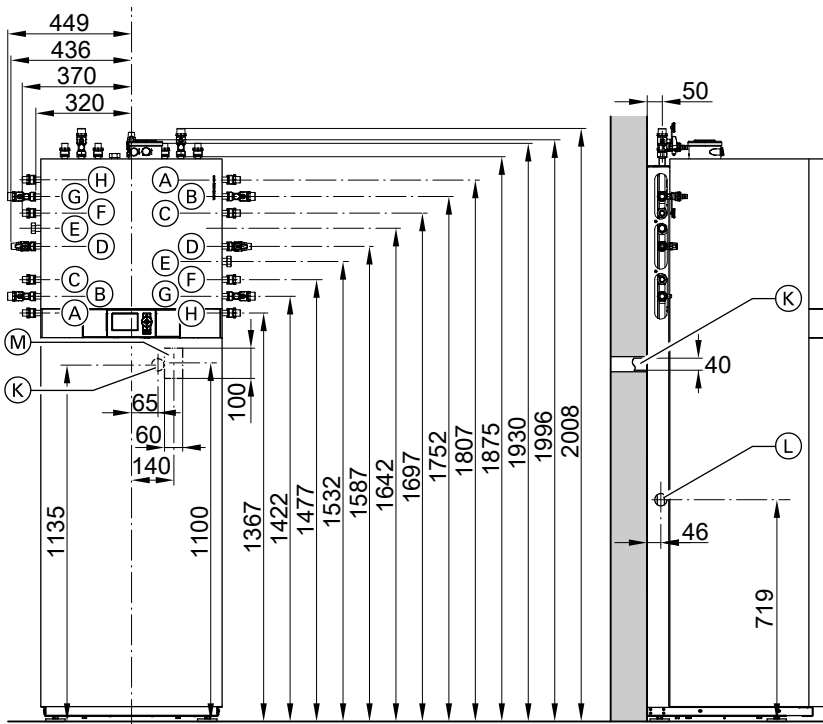

- (A) Solar return R 3/4"
- (B) Heating flow R 3/4"
- (C) DHW R 1/2"
- (D) Gas connection R 1/2"
- (E) DHW circulation R 1/2" (separate accessory)
- (F) Cold water R 1/2"
- (G) Heating return R 3/4"
- (H) Solar flow R 3/4"
- (K) Condensate drain to the back into the wall
- (L) Side condensate drain
- (M) Cable entry
- (N) DHW safety valve drain

Preparing for installation (cont.)

Note

The adjustable feet give all height measurements a tolerance of +15 mm.

1. Prepare the heating water connections.
Flush the heating system thoroughly.

Note

Should an additional diaphragm expansion vessel be required on site, connect that vessel into the heating return.

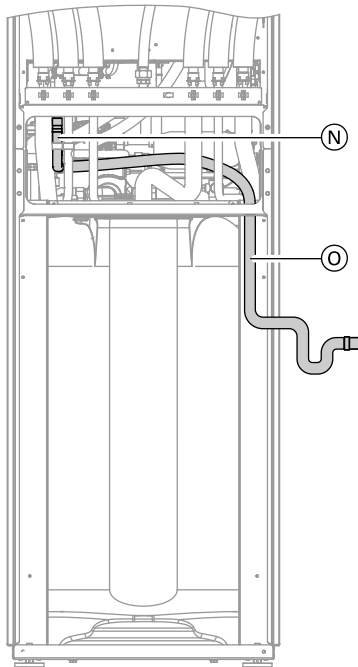

2. Prepare the DHW connections. Install the safety assembly (accessory or on-site provision) in accordance with The Water Fittings Regulations 1999 in the cold water line (see page 9).
Recommendation:
Install the safety valve above the DHW cylinder to protect it against contamination, scaling and high temperatures.
Connect the drain hose to the condensate collector. Remove plug from condensate collector.
3. Route condensate hose (O) to the back (drain in wall (K)) or to the side aperture (L) (see page 6).
Route condensate hose with a U-bend and connect to on-site drain line or siphon. Discharge pipes from expansion valves (safety valve) should not be connected directly to a drain and should pass through a visible tundish, with a AUK3 air gap, and be located adjacent to the device.

Preparing for installation (cont.)

4. Prepare the gas connection according to TRGI or TRF or all local regulations.
5. Prepare the electrical connections.
 - Power supply cable: NYM-J 3 x 1.5 mm², fuse max. 16 A, 230 V/50 Hz.
 - Accessory cables: NYM with the required number of conductors for the external connections.
 - Allow all cables in area "M" (see page 7) to protrude 2000 mm from the wall.

Safety assembly to Water Fittings regulations 1999

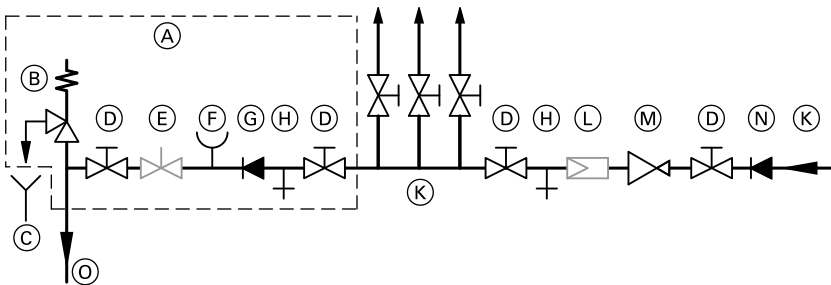

- | | |
|--|---|
| (A) Safety assembly to Water Fittings regulations 1999 (accessory to connection sets for unfinished walls) | (G) Non-return valve |
| (B) Safety valve | (H) Drain |
| (C) Visible blow-off line outlet | (K) Cold water |
| (D) Shut-off valve | (L) Drinking water filter |
| (E) Flow regulating valve (installation recommended) | (M) Pressure reducer to Water Fittings regulations 1999 |
| (F) Pressure gauge connection | (N) Non-return valve/pipe separator |
| | (O) Cold water connection at connection set (accessory) |

Installing the boiler

Assembling the boiler

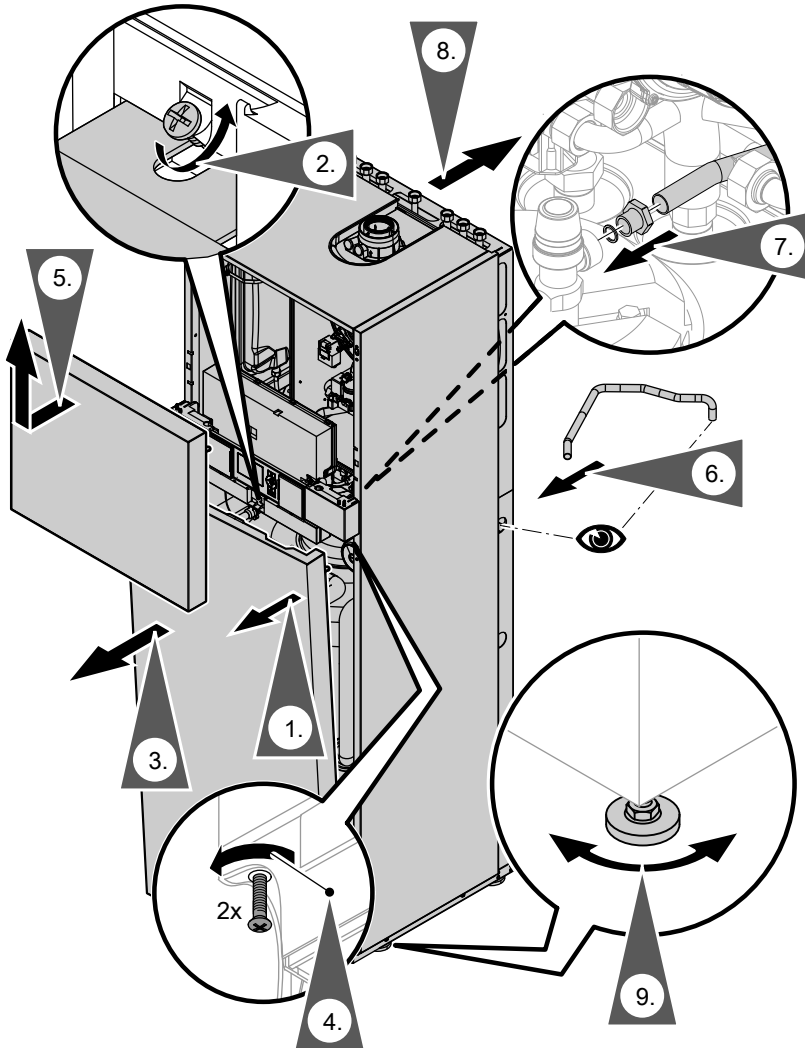

Installing the boiler (cont.)

Connections on the heating water and the DHW side

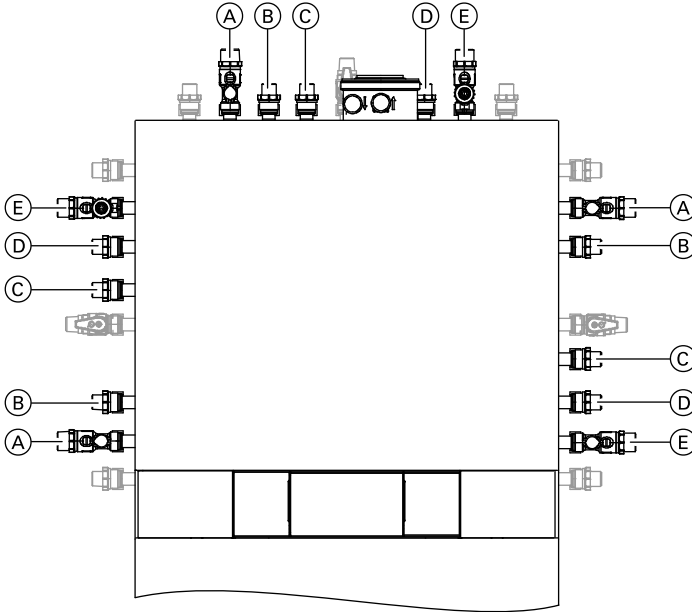

Shown with connection sets for finished walls (accessories)

- Ⓐ Heating flow R 3/4"
- Ⓑ DHW R 1/2"
- Ⓒ DHW circulation R 1/2" (separate accessory)
- Ⓓ Cold water R 1/2"
- Ⓔ Heating return R 3/4"

Fitting the drain outlet and drain line to the T&P valve



Separate installation instructions

Installing the boiler (cont.)

DHW circulation connection

DHW circulation connection with DHW circulation pump connection set (accessory)



Separate installation instructions

Connections on the solar side

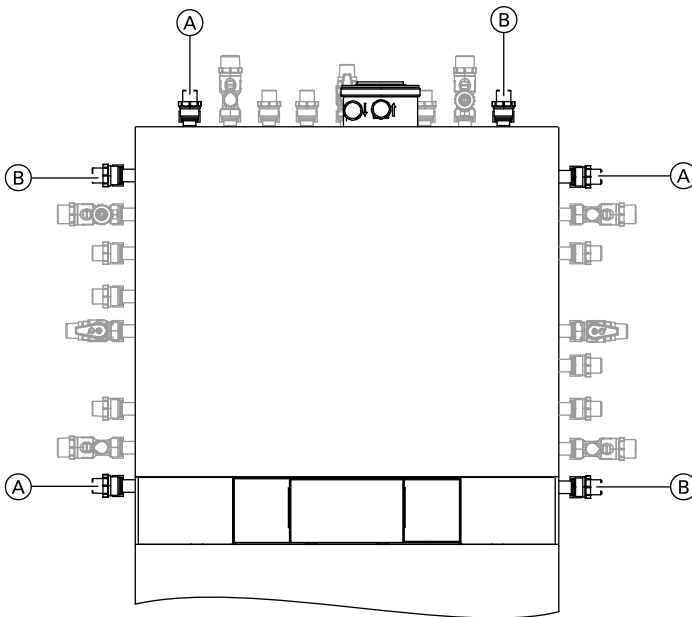

Shown with connection sets for finished walls (accessories)

(A) Solar return R $\frac{3}{4}$ "

(B) Solar flow R $\frac{3}{4}$ "

Note

The solar circuit pump is integrated into the boiler.

Install the expansion vessel, available as an accessory, in the solar return on site.

Installing the boiler (cont.)



Separate installation instructions

Note

Route the blow-off pipe for the safety valve on the solar side into a suitable and adequately sized drip container.

Set the safety valve on the solar side and the pressure gauge for the solar circuit on site.

Gas connection

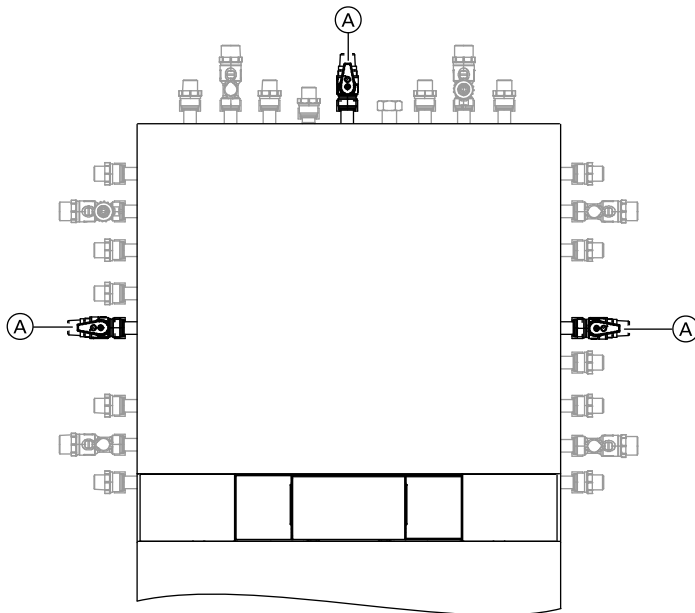

(A) Gas connection R ½"

Notes regarding operation with LPG.

We recommend the installation of an external safety solenoid valve when installing the boiler in rooms below ground level.

2. Carry out a tightness test.

1. Fix gas shut-off valve to gas connection (A).

Installing the boiler (cont.)

Note

For the tightness test, use only suitable and approved leak detecting agents (EN 14291) and devices.

Leak detecting agents with unsuitable contents (e.g. nitrides, sulphides) can lead to material damage.

Remove residues of the leak detecting agent after testing.



Please note

Excessive test pressure may damage the boiler and the gas valve.

Max. test pressure 150 mbar.

Where higher pressure is required for tightness tests, separate the boiler and the gas valves from the gas supply pipe (undo the fitting).

3. Vent the gas line.

For conversion to a different gas type see page 30

Flue gas connection

Connect the balanced flue. The flue terminals have to be installed as described in accordance with the Building Regulations Part J and BS 5440.



Flue gas system installation instructions.

Opening the control unit casing

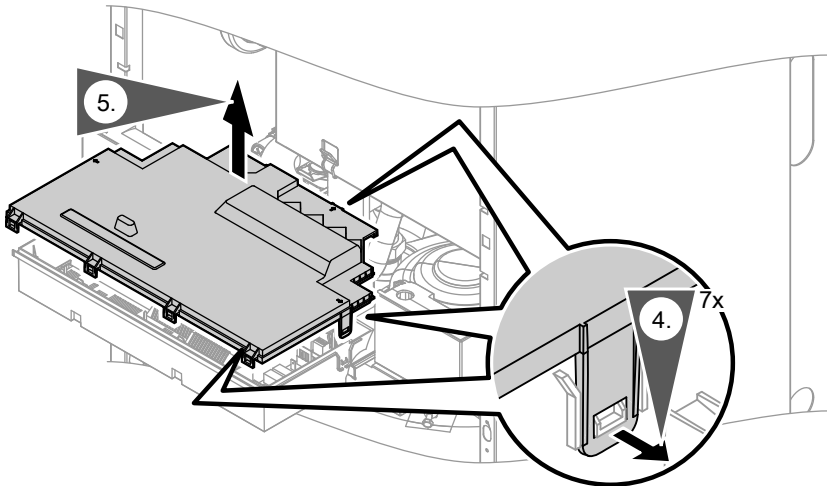
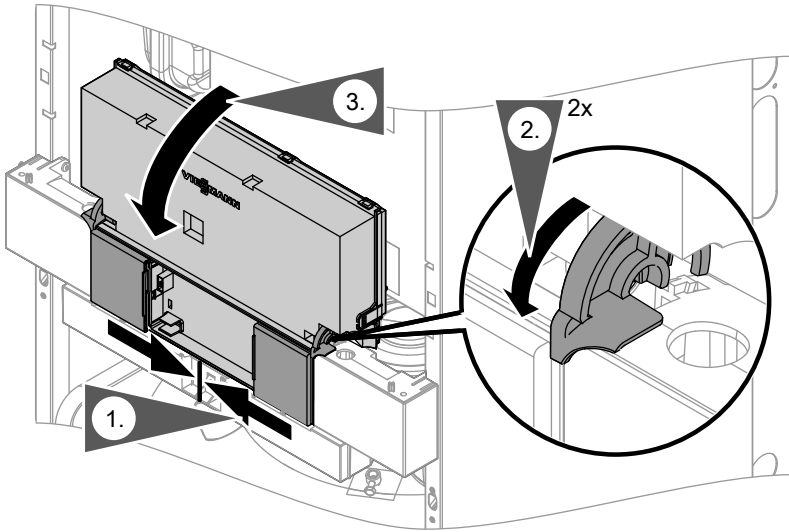

Electrical connections



Information regarding the connection of accessories

For the connection, observe the separate installation instructions provided with the accessory components.



Please note

Electronic modules can be damaged by electrostatic discharges. Before beginning work, touch earthed objects, such as heating or water pipes, to discharge static loads.

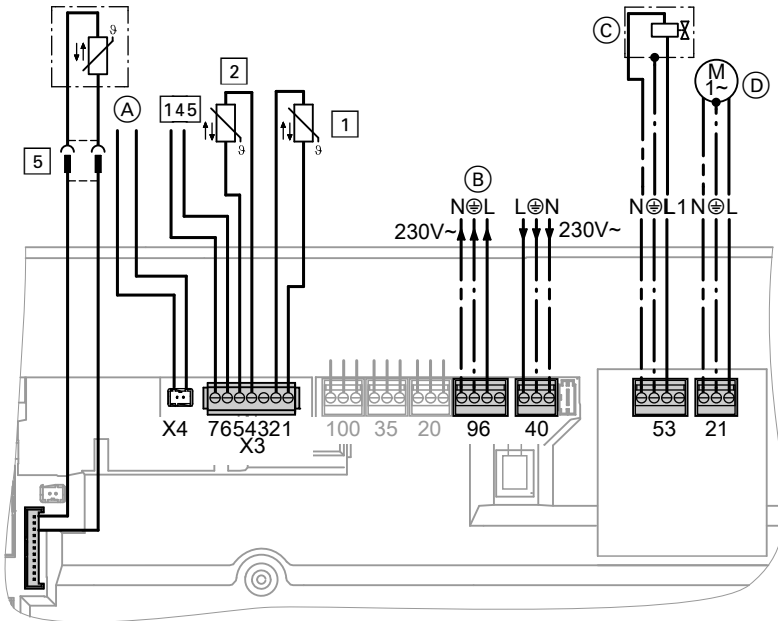

(A) Solar control module KM BUS connection (connected in the delivered condition)

(B) Solar control module power supply

(C) External safety solenoid valve (LPG)

(D) Cyl. primary pump

Plug 230 V~

[21] Cylinder primary pump (E) (fitted and connected)

[40] Power supply

Electrical connections (cont.)



Danger

Incorrect core termination can cause severe injuries and damage to the equipment.

Take care **not** to interchange cores "L1" and "N".

- Remove any existing individual cores.
- Install an isolator in the power supply line that simultaneously isolates all non-earthed conductors from the mains with at least 3 mm contact separation.

Remove the existing cable grommet when using larger cross-sections (up to $\varnothing 14$ mm). Secure the cable with cable grommet (F) (see page 19) integrated into the casing base.

- Max. fuse rating 16 A.

- 53 External safety solenoid valve (LPG) (D)

Do **not** remove jumper between "1" and "L" when making this connection.

- 96 Accessories and solar control module power supply

Where the boiler is installed in a wet area, the connection of accessories to the power supply must not be carried out at the control unit. The power supply connection for accessories can be made immediately at the control unit, if the boiler is installed outside wet areas. This connection is controlled directly with the system ON/OFF switch (max. 3 A)

Low voltage plug X3

- 1 Outside temperature sensor (only for weather-compensated control units)

Installation:

- North or north-western wall, 2 to 2.5 m above ground level; in multi-storey buildings, in the upper half of the second floor
- Not above windows, doors or ventilation outlets
- Not immediately below balconies or gutters
- Never render over
- Cable length max. 35 m with a cross-section of 1.5 mm²

- 2 Flow temperature sensor for low loss header (accessories)

- 5 Cylinder temperature sensor (fitted and connected)

- 145 KM BUS subscriber (accessory)

- Vitotrol 200 or 300 remote control (only for weather-compensated control units)
- Extension kit for one heating circuit with mixer (only for weather-compensated control units)
- External extension H1 or H2
- Open Therm extension

Electrical connections (cont.)

Connecting the collector temperature sensor

Note

Solar control module (A) is attached to the l.h. side of the air box.

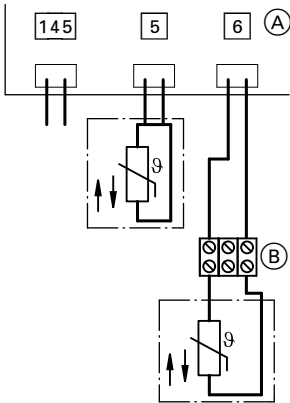

Connect collector temperature sensor (6) to terminal box (B) of the prewired lead connected to solar control module (A).

On-site extension cable: 2-core, cross-section 1.5 mm².

- 5 Cylinder temperature sensor (fitted and connected)

Electrical connections (cont.)

Routing the connecting cables



Please note

Connecting cables will be damaged if they touch hot parts. When routing and securing power cables on site, ensure that the maximum permissible temperatures for these cables are not exceeded.

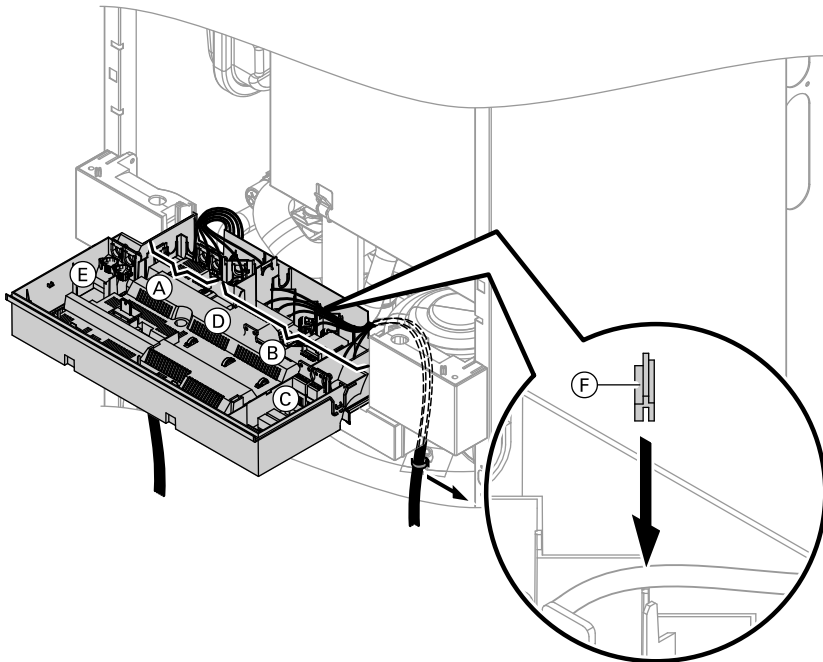

- (A) Low voltage connections
- (B) 230 V connections
- (C) Internal extension
- (D) Main PCB

- (E) Communication module (accessories)
- (F) Cable grommet for power supply cable

Closing the control unit casing

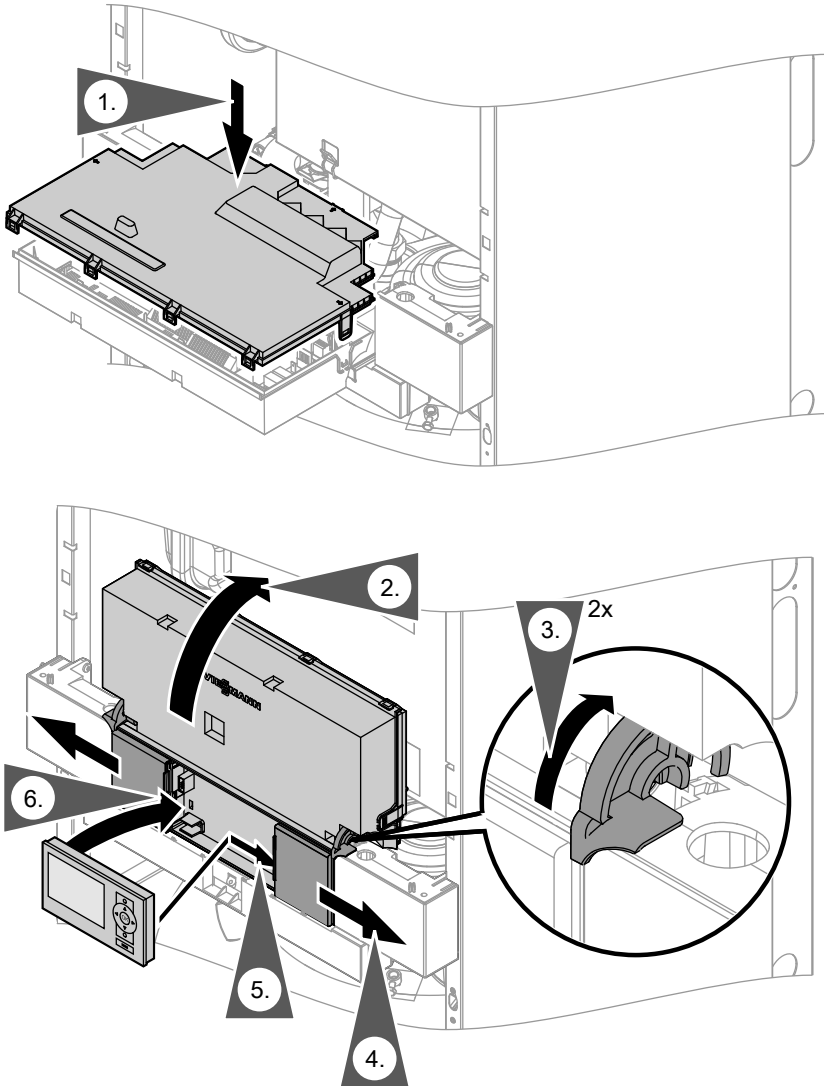

Close control unit casing and insert programming unit, packed separately.

Note

The programming unit can also be used in a wall mounting base (accessory) near the boiler.

Closing the control unit casing (cont.)



Wall mounting base installation
instructions

Steps - commissioning, inspection and maintenance

For further information regarding the individual steps, see the page indicated

				Page
			Commissioning steps	
			Inspection steps	
			Maintenance steps	
			1. Removing the front panels.....	24
			2. Filling the heating system.....	24
			3. Changing the language (if required).....	25
			4. Setting the time and date (if required).....	26
			5. Venting the boiler.....	26
			6. Venting the heating system.....	26
			7. Filling siphon with water.....	27
			8. Filling the solar circuit.....	28
			9. Checking all connections on the heating water side and DHW side for leaks	
			10. Checking power supply connection	
			11. Naming the heating circuits.....	28
			12. Checking the gas type.....	29
			13. Gas type conversion (only for operation with LPG)....	30
			14. Function sequence and possible faults.....	30
			15. Checking the static and supply pressure.....	32
			16. Setting the maximum output.....	33
			17. Checking the balanced flue system tightness (annular gap check).....	34
			18. Burner removal.....	35
			19. Checking the burner gasket and the burner gauze assembly.....	36
			20. Checking and adjusting the ignition and ionisation electrodes.....	37
			21. Cleaning the heat exchanger and fitting the burner....	37
			22. Checking the condensate drain and cleaning the siphon.....	39

Steps - commissioning, inspection and... (cont.)

				Page
			Commissioning steps	
			Inspection steps	
			Maintenance steps	
		•	23. Checking the neutralising system (if installed)	
•			24. Checking the anode connection.....	40
		•	25. Testing the anode earth current with an anode tester	40
		•	26. Draining the boiler on the DHW side.....	42
		•	27. Cleaning the primary cylinder.....	43
		•	28. Checking and replacing the magnesium anode (if required).....	44
		•	29. Returning the primary cylinder into use.....	45
	•	•	30. Checking the diaphragm expansion vessel and system pressure.....	46
•	•	•	31. Checking the function of safety valves	
•	•	•	32. Checking electrical connections for tightness	
•	•	•	33. Checking gas equipment for tightness at operating pressure.....	46
•	•	•	34. Checking the combustion quality.....	47
•	•	•	35. Checking the external LPG safety valve (if installed)	
•			36. Matching the control unit to the heating system.....	48
•			37. Adjusting the heating curves.....	54
•			38. Connecting the control unit to the LON.....	56
•	•	•	39. Scanning and resetting the "Service" display.....	58
•	•	•	40. Fitting the front panels.....	59
•			41. Instructing the system user.....	60

Further details regarding the individual steps

Removing the front panels

See page 10, steps 1 to 5.

Filling the heating system



Please note

- Unsuitable fill water increases the level of deposits and corrosion and may lead to boiler damage.
 - Thoroughly flush the entire heating system prior to filling it with water.
 - Only use fill water of potable quality.
 - Soften fill water with hardness exceeding 300ppm (3.0 mmol/l), e.g. use a small softening system for heating water (see Vitoset price list).
 - An antifreeze additive suitable for heating systems can be mixed with the fill water.

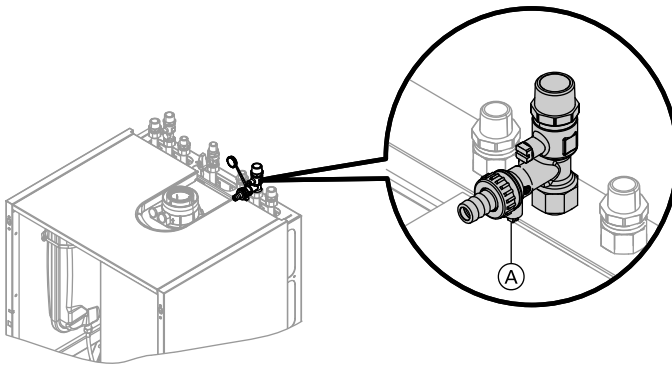

Shown with connection set for finished walls (accessory)

1. Check the pre-charge pressure of the diaphragm expansion vessel.
2. Close the gas shut-off valve.
3. Fill heating system via boiler fill & drain valve (A) in the heating return (at the connection set on the side or above the boiler). (Minimum system pressure > 1.0 bar).

Further details regarding the individual steps (cont.)

Note

If the control unit has not been switched ON prior to filling the system, then the servomotor of the diverter valve will still be in its central position, and the system will be completely filled.

Note

Lever on valve (B) must be in the "l.h." position.

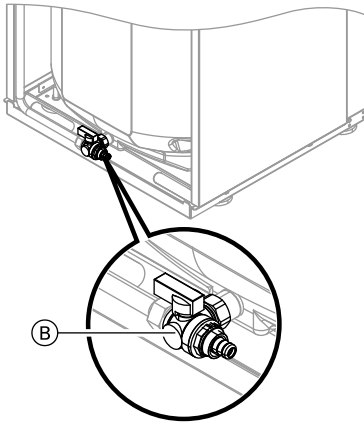

- If the control unit had already been switched ON before filling began: Switch control unit ON and activate filling program (see next steps).

Note

For function and details of the fill program, see page 113.

- Close boiler fill & drain valve (A).

Activating the filling function:

- Press **OK** and **≡**: simultaneously for approx. 4 s.
- "Service functions"
- "Filling"
- Ending filling function:
Press **OK** or **↶**.

Changing the language (if required)

Note

At the commissioning stage, the display is in German (default setting)

Extended menu:

- ≡**
- "Settings"

- "Language"

Sprache	
Deutsch	DE <input checked="" type="checkbox"/>
Cesky	CZ <input type="checkbox"/>
Dansk	DK <input type="checkbox"/>
English	GB <input type="checkbox"/>
Wählen mit ↕	

- Set the required language with **▲/▼**.

Further details regarding the individual steps (cont.)

Setting the time and date (if required)

During commissioning, or after prolonged time out of use, the time and date need to be reset.

Extended menu:

1. ☰:

2. "Settings"

3. "Time / Date"

4. Set current time and date.

Venting the boiler

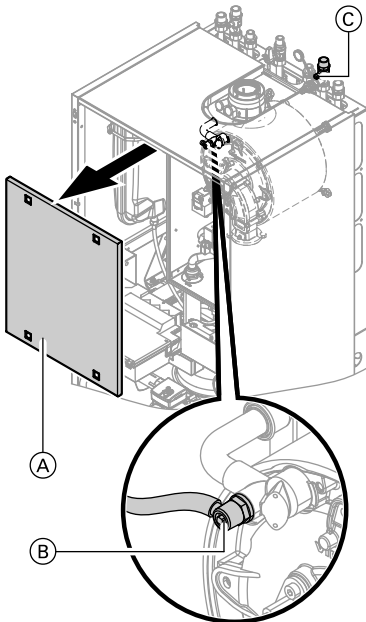

1. Close the shut-off valves on the heating water side.

2. Remove cover panel (A).

3. Connect the drain hose on valve (B) with a drain.

4. Open air vent valve (B) and fill valve (C) in the heating return and vent using mains pressure (flush) until no more air noise can be heard.

5. Close valve (B) and fill valve (C) in the heating return, and open the shut-off valves on the heating water side.

Venting the heating system

1. Close the gas shut-off valve and switch ON the control unit.

2. Activate venting program (see next steps).

Further details regarding the individual steps (cont.)

Note

For function and sequence of the venting program, see page 113.

3. Check the system pressure.

Activating the venting function:

1. Press **OK** and **≡** simultaneously for approx. 4 s.

Filling siphon with water

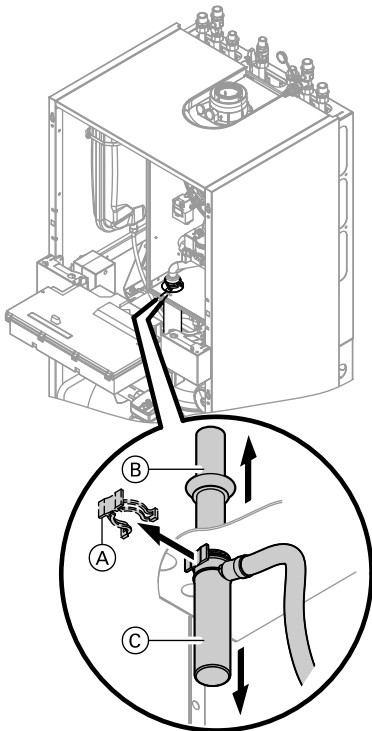

2. "Service functions"

3. "Air vent valve"

4. Ending venting function:
Press **OK** or ↶.

1. Pivot control unit forward.
2. Pull retaining clip (A) off.
3. Pull filler pipe (B) upwards.
4. Pull off lute (C) downwards.
5. Fill siphon with water and reassemble.
6. Refit cover panel.
7. Secure control unit back in operating position.

Further details regarding the individual steps (cont.)

Filling the solar circuit



Solar thermal system installation and service instructions

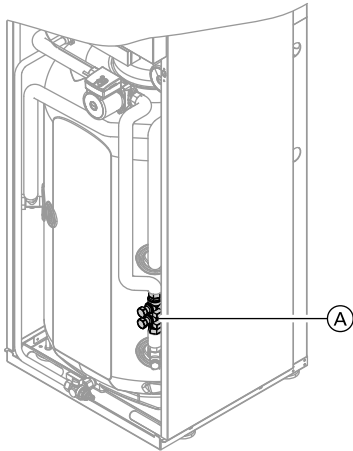

(A) Solar circuit fill valve



Please note

Overheated collector areas and overheated heat transfer medium can cause burns/scalding and equipment damage. When working on the collector and the solar circuit, protect the collector area against solar irradiation.

1. Thoroughly flush the on-site pipework.

Naming the heating circuits

In the delivered condition, the heating circuits are designated "Heating circuit 1" and "Heating circuit 2" (if installed).

2. Fill the solar circuit via fill valve (A) with "Tyfocor LS".
Minimum system pressure: 1.7 bar.
Permiss. operating pressure: 6 bar.



Please note

To prevent equipment damage, use only "Tyfocor LS".
Never fill with water!

3. Close ball valve of fill valve (A).
4. Open the air vent valve at the solar collector.
5. Start solar circuit pump via a relay test (see page 83).
6. Let the solar circuit pump run until the solar circuit is fully vented. At a system pressure below 1.7 bar top up with "Tyfocor LS".
7. Close the air vent valve at the solar collector.
8. Check system pressure. Below 1.7 bar top up with "Tyfocor LS".

If the system user prefers, the heating circuits can be designated differently to suit the specific system.

Further details regarding the individual steps (cont.)

Enter names for heating circuits:



Operating instructions

Checking the gas type

The boiler is equipped with an electronic combustion control unit that adjusts the burner for optimum combustion in accordance with the prevailing gas quality.

- Consequently, for natural gas there is no adjustment required across the entire Wobbe range.

The boiler can be operated in the Wobbe index range 9.5 to 15.2 kWh/m³ (34.2 to 54.7 MJ/m³).

- Convert the burner for operation with LPG (see "Gas type conversion" on page 30).

1. Determine the gas type and Wobbe index by asking your local gas supply utility or LPG supplier.
2. Convert the burner for operation with LPG (see page 30).
3. Record the gas type in the service report on page 135.

Further details regarding the individual steps (cont.)

Gas type conversion (only for operation with LPG)

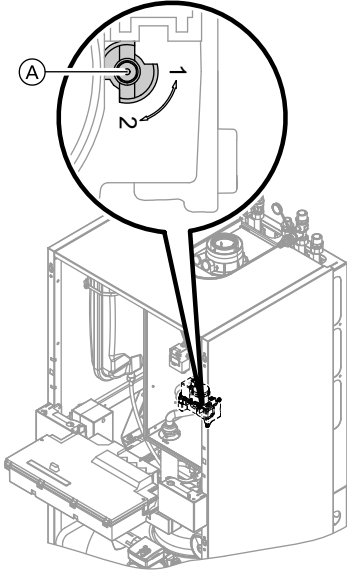

1. Set adjusting screw (A) at the gas train to "2".
2. Switch ON/OFF switch (D) ON.
3. Select the gas type in coding address "82":
 - Call up code 2 (see page 72)
 - Call up general
 - In coding address "11", select value "9".
 - In coding address "82", select value "1" (operation with LPG).
 - In code "11" select value \neq "9".
 - End service functions.
4. Open the gas shut-off valve.
5. Affix label "G31" (included with the technical documentation) adjacent to the type plate on the cover panel.

Function sequence and possible faults

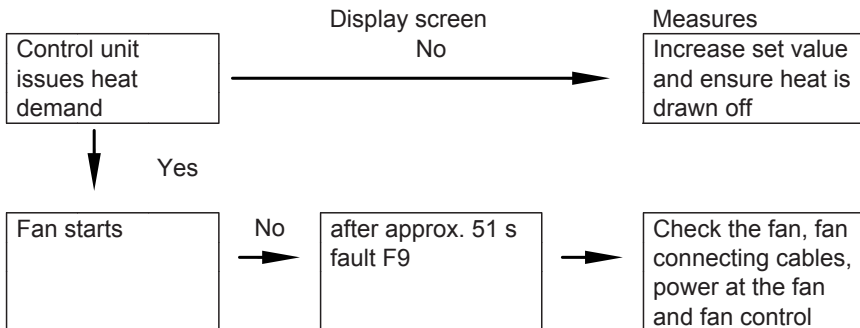

Further details regarding the individual steps (cont.)

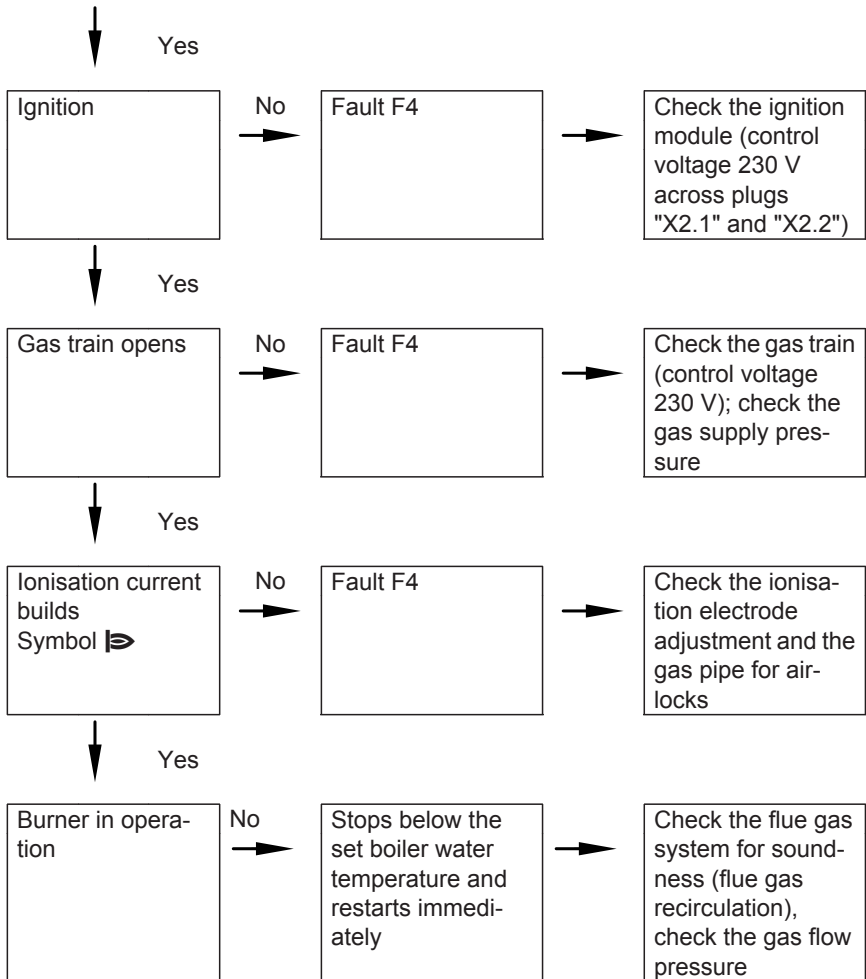

Further details regarding the individual steps (cont.)

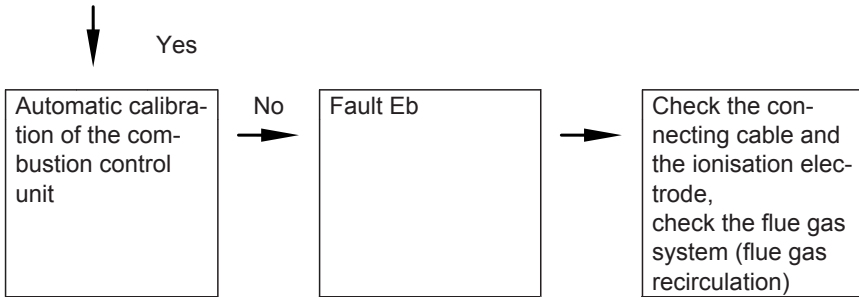

For further details regarding faults, see page 85.

Checking the static and supply pressure



Danger

CO build-up as a result of an incorrect burner setup can have serious health implications.

Carry out a CO test prior to and after work on gas equipment.

Operation with LPG

Flush the LPG tank twice during commissioning/replacement. Thoroughly vent the tank and gas supply lines after flushing.

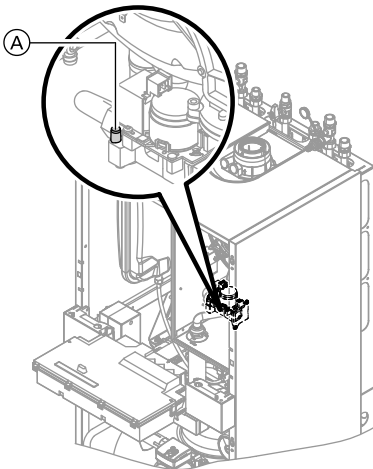

1. Close the gas shut-off valve.
2. Undo the screw inside test connector "PE" (A) at the gas train but do not remove it, and connect the pressure gauge.
3. Open the gas shut-off valve.
4. Measure the static pressure and record it in the service report on page 135.
Set value: max. 37 mbar

Further details regarding the individual steps (cont.)

5. Start the boiler.

Note

During commissioning, the boiler can enter a fault state because of airlocks in the gas line. After approx. 5 s press the reset button **R** (see operating instructions) to reset the burner.

6. Check the supply (flow) pressure.

Set value:

- Natural gas: 20 mbar
- LPG: 37 mbar

Note

Use suitable test equipment with a resolution of at least 0.1 mbar to measure the supply pressure.

7. Record the actual value in the service report on page 135.

Take the action shown in the following table.

8. Shut down the boiler, close the gas shut-off valve, remove the pressure gauge and close test nipple (A) with the screw.

9. Open the gas shut-off valve and start up the boiler.



Danger

Gas escaping from the test nipple leads to a risk of explosion.

Check test connector (A) for tightness.

Supply (flow) pressure for natural gas	Supply (flow) pressure for LPG	Measures
below 15 mbar	below 25 mbar	Do not start the boiler. Notify your mains gas or LPG supplier.
15 to 25 mbar	25 - 45 mbar	Start the boiler.
above 25 mbar	above 45 mbar	Install a separate gas pressure governor upstream of the system and regulate the pre-charge pressure to 20 mbar for natural gas or 37 mbar for LPG. Notify your mains gas or LPG supplier.

Setting the maximum output

You can limit the maximum output for **heating operation**. The limit is set via the modulation range. The max. adjustable heating output is limited upwards by the boiler coding card.

1. Press **OK** and  simultaneously for approx. 4 s.
2. "Service functions"
3. "Max. output"



Further details regarding the individual steps (cont.)

4. "Change?" Select "Yes".

A value flashes on the display (e.g. "85"). In the delivered condition, this value represents 100 % of rated output.

5. Set the required value.

Checking the balanced flue system tightness (annular gap check)

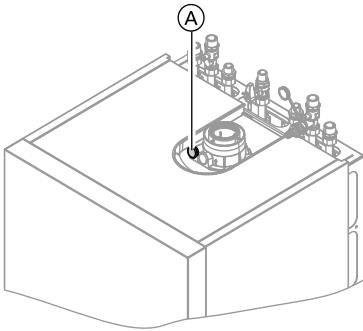

Ⓐ Combustion air port (ventilation air)

For balanced flue systems tested together with the wall mounted gas fired boiler, the requirement for a tightness test during commissioning by the flue gas inspector is not applicable.

We recommend that your heating engineer carries out a simple leak/tightness test during the commissioning of your system. For this, it would be sufficient to check the CO_2 or O_2 concentration in the combustion air at the annular gap of the balanced flue pipe.

The flue pipe is deemed to be gas-tight if the CO_2 concentration in the combustion air is no higher than 0.2 % or the O_2 concentration is at least 20.6 %.

If actual CO_2 values are higher or O_2 values are lower, then pressure test the flue pipe with a static pressure of 200 Pa.

Further details regarding the individual steps (cont.)

Burner removal

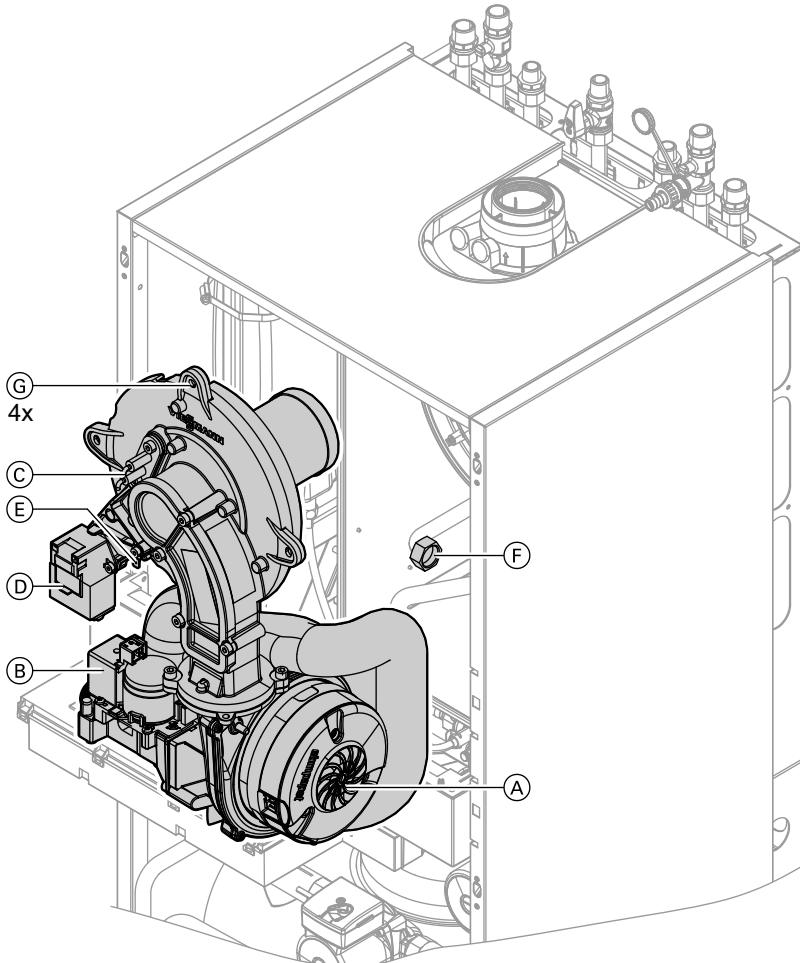

1. Switch ON/OFF switch ① at the control unit and the main power supply OFF.
2. Close the gas shut-off valve and safeguard against reopening.

Further details regarding the individual steps (cont.)

3. Pull electrical cables from fan motor (A), gas valve (B), ionisation electrode (C), ignition unit (D) and earth tab (E).
 4. Undo gas supply pipe fitting (F).
 5. Release four nuts (G) and remove the burner.
- !** **Please note**
Prevent damage to the wire gauze.
Never rest the burner on the gauze assembly.

Checking the burner gasket and the burner gauze assembly

Check burner gasket (A) and burner gauze assembly (E) for damage and replace, if required.

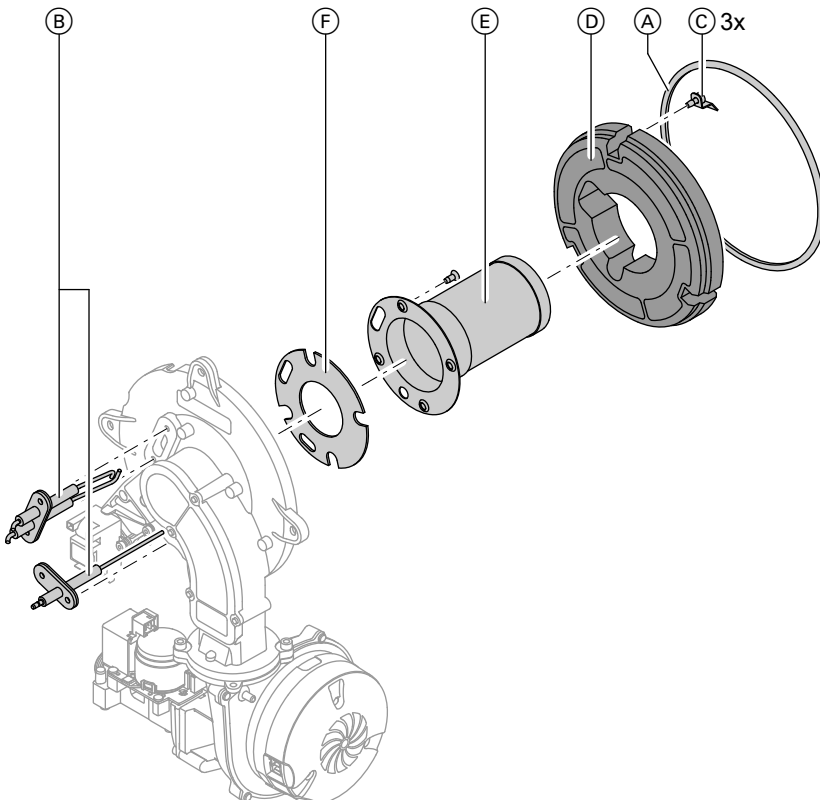

Further details regarding the individual steps (cont.)

1. Remove electrodes (B).
2. Undo three retaining clips (C) at thermal insulation ring (D) and remove thermal insulation ring (D).
3. Undo four Torx screws and remove burner gauze assembly (E) with its gasket (F).
4. Insert and secure a new burner gauze assembly (E) with a new gasket (F).
Torque: 3.5 Nm.
5. Refit thermal insulation ring (D).
6. Refit electrodes (B).
Torque: 2.5 Nm.

Checking and adjusting the ignition and ionisation electrodes

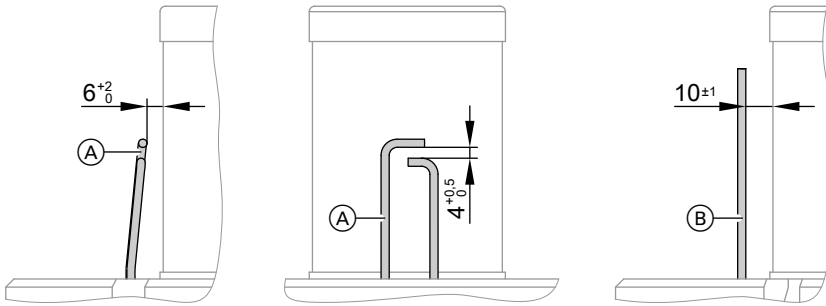

(A) Ignition electrodes

(B) Ionisation electrode

1. Check the electrodes for wear and contamination.
2. Clean the electrodes with a small brush (not with a wire brush) or sand paper.
3. Check the electrode gaps. If the gaps are not as specified or the electrodes are damaged, replace and align the electrodes together with new gaskets. Tighten the electrode fixing screws with 2.5 Nm.

Cleaning the heat exchanger and fitting the burner



Please note

Scratches on parts that are in contact with flue gas can lead to corrosion.
Never use brushes to clean the heat exchanger.

Further details regarding the individual steps (cont.)

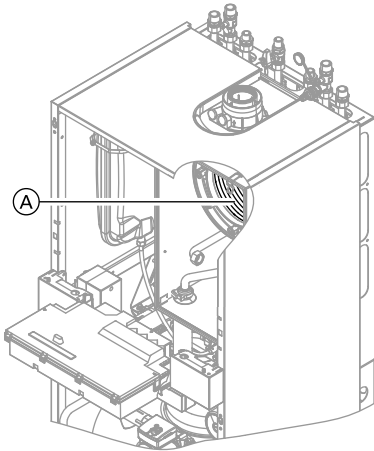

1. Use a vacuum cleaner to remove residues from the heat exchanger (A) inside the combustion chamber.
2. If required, spray slightly acidic, chloride-free cleaning agents based on phosphoric acid onto heat exchanger (A) and let the solution soak in for approx. 20 min.
3. Thoroughly flush the heat exchanger (A) with water.
4. Install the burner. Fit the screw with a serrated washer and the remaining screws, then tighten diagonally with 4 Nm torque.
5. Fit the gas supply pipe with a new gasket.
6. Check the gas connections for tightness.



Danger

Escaping gas leads to a risk of explosion.

Check all fittings for gas tightness.

7. Connect the electrical cables/leads to each corresponding component.

Further details regarding the individual steps (cont.)

Checking the condensate drain and cleaning the siphon

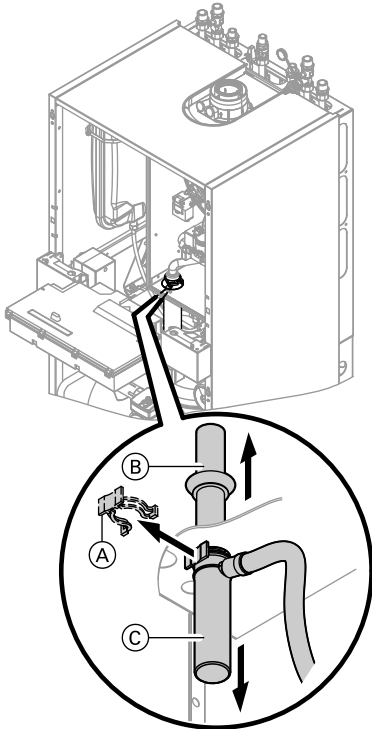

1. Check that the condensate can drain freely at the siphon.
2. Pull retaining clip (A) off.
3. Pull filler pipe (B) upwards.
4. Pull off lute (C) downwards.
5. Pull the condensate hose from lute (C).
6. Clean the siphon.
7. Fill siphon with water and reassemble.

Further details regarding the individual steps (cont.)

Checking the anode connection

Check that the earth lead is connected to the magnesium anode.

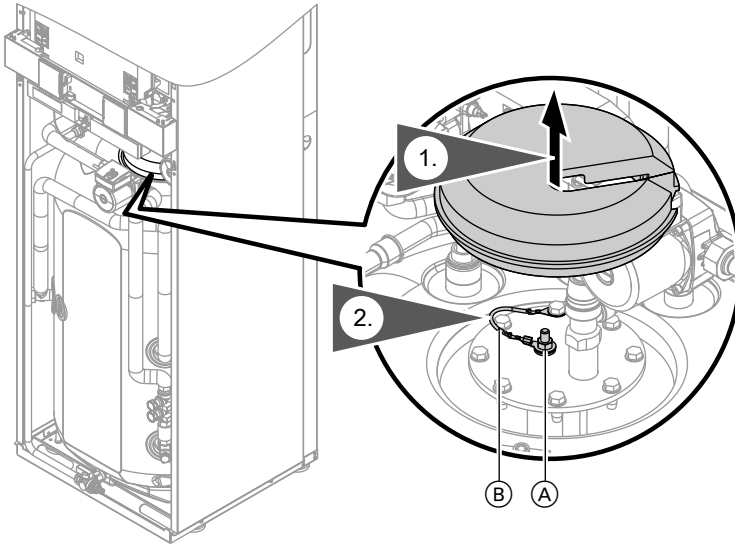

(A) Magnesium anode

(B) Earth cable

Testing the anode earth current with an anode tester

Note

We recommend that the magnesium anode function is checked annually. This function test can be carried out without interrupting operation, by measuring the earth current with an anode tester.

Further details regarding the individual steps (cont.)

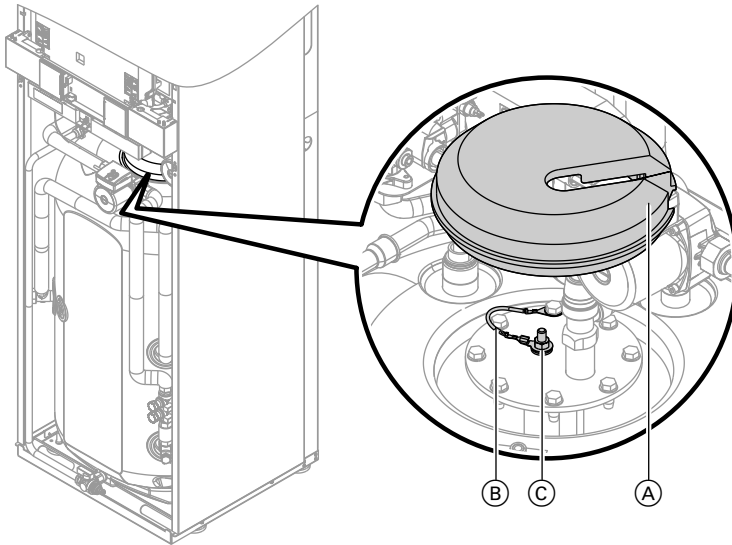

1. Remove cover (A).
2. Pull earth lead (B) from tab (C).
3. Connect the tester (up to 5 mA) in series between tab (C) and earth cable (B).
 - The anode is OK if the indicated current is > 0.3 mA.
 - Visually inspect the anode, if the current measures < 0.3 mA or if there is no current at all (see page 44).

Further details regarding the individual steps (cont.)

Draining the boiler on the DHW side

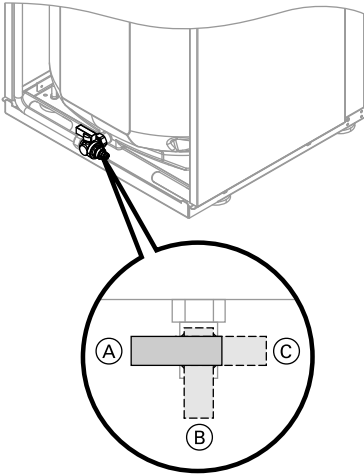

1. Connect hose to drain valve and route into a suitable container or drain outlet.

Note

Ensure adequate ventilation in the DHW pipework.

2. Turn drain valve from lever position (A) to lever position (B) or (C) as required.
 - Lever position (B): Drain heating system **excluding** cylinder via the cold water connection.
 - Lever position (C): Drain heating system **and** cylinder via the DHW connection. Cold water connection remains filled.

Further details regarding the individual steps (cont.)

Cleaning the primary cylinder

Note

EN 806 specifies a visual inspection and (if required) cleaning every two years after the cylinder has been taken into use and thereafter according to requirements.

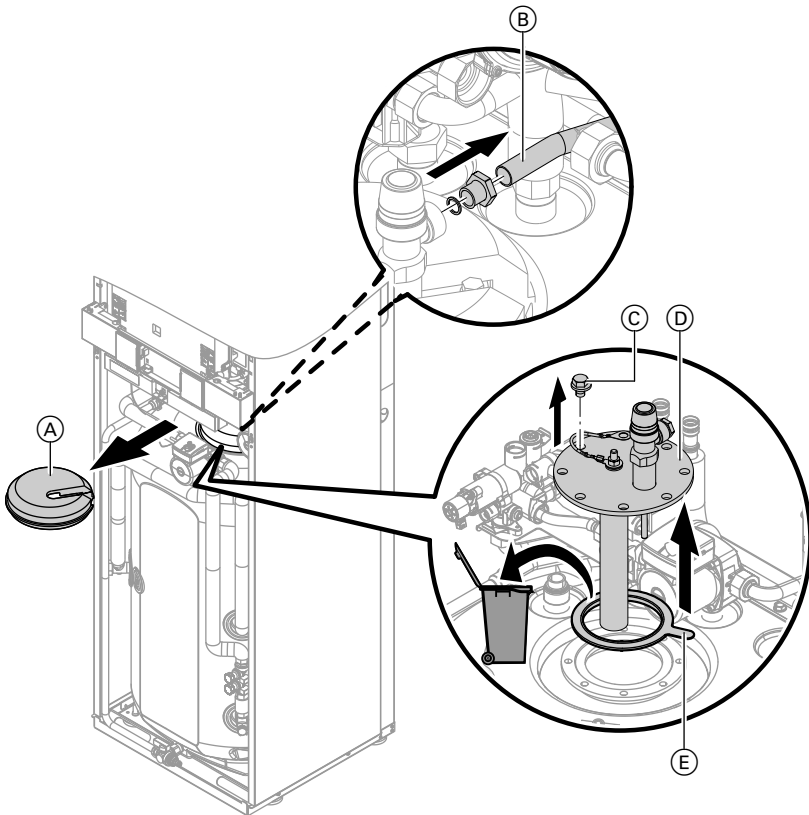

1. Drain the primary cylinder.
2. Remove flange lid (A).
3. Remove T&P valve (B).
4. Undo eight screws (C) and remove flange lid (D).
5. Dispose of gasket (E).
6. Disconnect the primary cylinder from the pipework to prevent contamination from entering the pipe system.

Further details regarding the individual steps (cont.)

7. Remove loose deposits with a high pressure cleaner.
9. Thoroughly flush the primary cylinder after cleaning.



Please note

When cleaning the inside, only use plastic cleaning utensils.

8. Use a chemical cleaning agent to remove hard deposits that cannot be removed by a high pressure cleaner.



Please note

Never use hydrochloric acid based cleaning agents.

Checking and replacing the magnesium anode (if required)

Check the magnesium anode. If it is discovered that the anode has degraded to 10 to 15 mm Ø, we recommend replacing the magnesium anode.

Further details regarding the individual steps (cont.)

Returning the primary cylinder into use

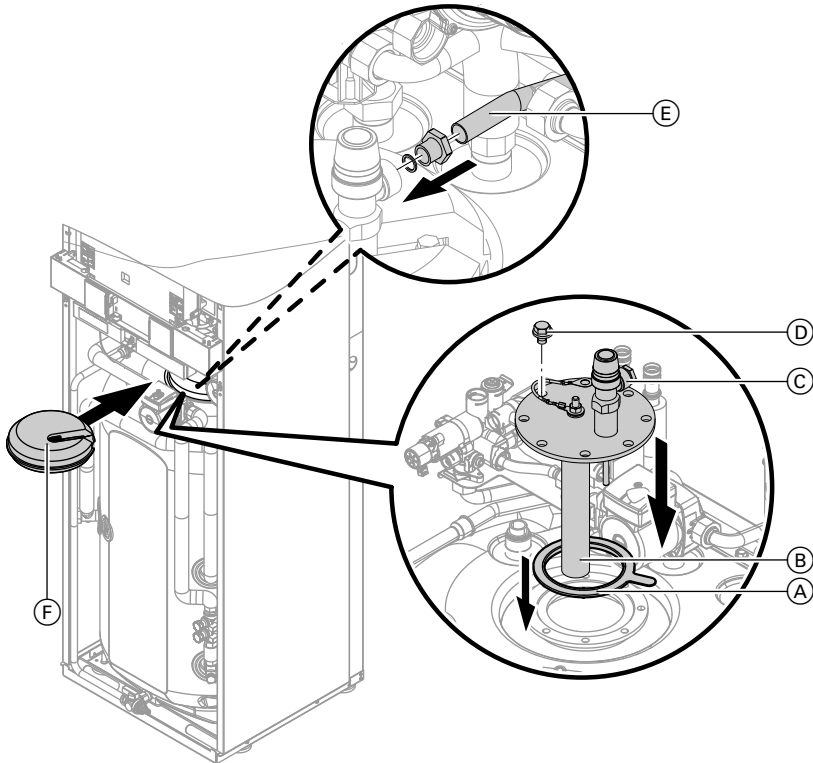

1. Reconnect the primary cylinder to the pipework.
2. Insert new gasket (A) underneath flange lid (B).
3. Fit flange lid (B) and tighten eight screws (D) with up to 25 Nm.
4. Push earth cable (C) onto the tab.
5. Fit T&P valve (E).
6. Fit cover (F).
7. Fill the primary cylinder with drinking water.

Further details regarding the individual steps (cont.)

Checking the diaphragm expansion vessel and system pressure

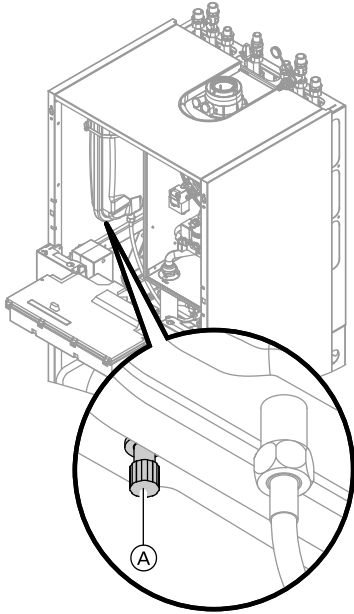

Note

Carry out this test on a cold system.

1. Drain the system, until the pressure gauge indicates "0".
2. If the diaphragm expansion vessel inlet pressure is lower than the static system pressure: Top up with nitrogen via connection (A), until the inlet pressure is 0.1 to 0.2 bar.
3. Top up your heating system with water and vent until the filling pressure of a cooled system is 0.1 to 0.2 bar higher than the inlet pressure of the diaphragm expansion vessel.
Permiss. operating pressure: 3 bar

Checking gas equipment for tightness at operating pressure



Danger

Escaping gas leads to a risk of explosion.
Check gas equipment for tightness.

Note

For the tightness test, use only suitable and approved leak detecting agents (EN 14291) and devices. Leak detecting agents with unsuitable contents (e.g. nitrides, sulphides) can lead to material damage.
Remove residues of the leak detecting agent after testing.

Further details regarding the individual steps (cont.)

Checking the combustion quality

The electronic combustion control unit automatically ensures an optimum combustion quality. Only the combustion values need to be checked during commissioning and maintenance. For this, check the CO₂ or O₂ content. For a function description of the electronic combustion control unit, see page 119.



Please note

- To prevent operating faults and equipment damage, never operate with dirty combustion air.

CO₂ or O₂ content

- The CO₂ content must be within the following ranges (upper and lower output):
 - 7.7 to 9.2% for natural gas H
 - 9.3 to 10.9% for LPG P
- For all gas types, the O₂ content must be between 4.4% and 6.9%.

If the actual CO₂ or O₂ values lie outside their respective ranges, proceed with the following steps:

- Check the balanced flue system for tightness, see page 34.
- Check the ionisation electrode and connecting cable, see page 37.

Note

During commissioning, the combustion control unit carries out an automatic calibration. Only test the emissions approx. 30 s after the burner has started.

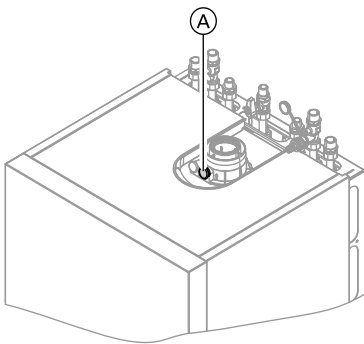

1. Connect a flue gas analyser at flue gas port (A) on the boiler flue connection.

2. Open the gas shut-off valve, start the boiler and create a heat demand.
3. Select the lower output (see page 48).
4. Check the CO₂ content. Should the actual value deviate from the above ranges by more than 1%, implement steps from page 47.
5. Enter actual values into the service report.
6. Select the upper output (see page 48).

Further details regarding the individual steps (cont.)

7. Check the CO₂ content. Should the actual value deviate from the above ranges by more than 1%, implement steps from page 47.
8. After testing, press **OK**.
9. Enter actual values into the service report.
2. **"Actuator test"**
3. Select the lower output:
Select **"Base load" "ON"** and confirm with **OK**.
4. Select the upper output:
Select **"Full load" "ON"** and confirm with **OK**.

To set the upper/lower output:

1. Press **OK** and  simultaneously for approx. 4 s.

Matching the control unit to the heating system

Subject to the equipment level, the control unit must be matched to the system. Various system components are recognised automatically by the control unit and the relevant codes are adjusted automatically.

- For the selection of an appropriate design, see the following diagrams.
- For coding steps, see page 61.

Further details regarding the individual steps (cont.)

System version 1

One heating circuit without mixer A1

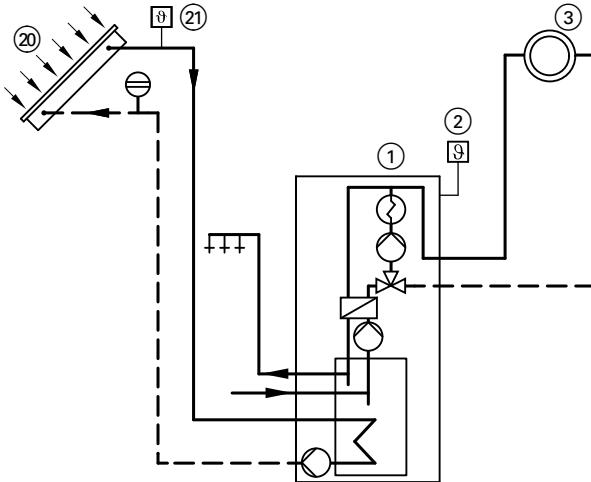

- ① Vitodens 242-F
- ② Outside temperature sensor
- ③ Heating circuit without mixer A1
- ⓪ Solar collectors
- ⓪ Collector temperature sensor

Required code

Operation with LPG

82:1

Further details regarding the individual steps (cont.)

System version 2

One heating circuit with mixer M2 and a low loss header

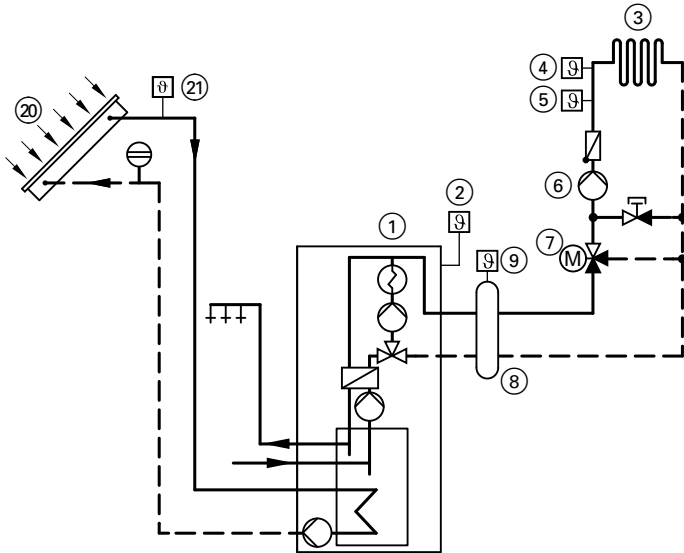

- | | |
|--|---|
| ① Vitodens 242-F | ⑦ Extension kit for one heating circuit with mixer M2 |
| ② Outside temperature sensor | ⑧ Low loss header |
| ③ Heating circuit with mixer M2 | ⑨ Flow temperature sensor, low loss header |
| ④ Temperature limiter for limiting the maximum temperature of underfloor heating systems | ⑩ Solar collectors |
| ⑤ Flow temperature sensor M2 | ⑪ Collector temperature sensor |
| ⑥ Heating circuit pump M2 | |

Required coding

Operation with LPG	82:1
System with only one heating circuit with mixer and DHW heating	00:4

Further details regarding the individual steps (cont.)

System version 3

One heating circuit without mixer A1 and one heating circuit with mixer M2

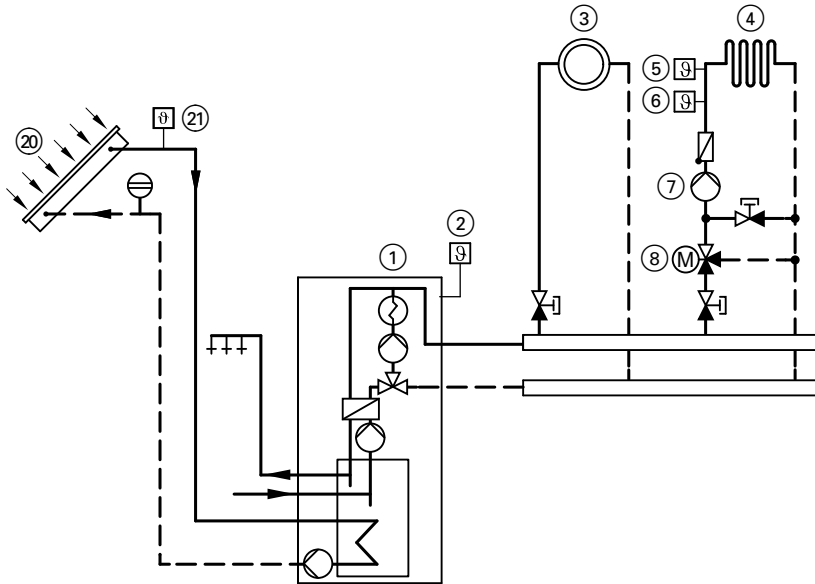

- | | |
|--|---|
| ① Vitodens 242-F | ⑥ Flow temperature sensor M2 |
| ② Outside temperature sensor | ⑦ Heating circuit pump M2 |
| ③ Heating circuit without mixer A1 | ⑧ Extension kit for one heating circuit with mixer M2 |
| ④ Heating circuit with mixer M2 | ⑩ Solar collectors |
| ⑤ Temperature limiter for limiting the maximum temperature of underfloor heating systems | ⑪ Collector temperature sensor |

Note

The volume flow of the heating circuit without mixer must be at least 30% greater than the volume flow of the heating circuit with mixer.

Required coding

Operation with LPG

82:1

Further details regarding the individual steps (cont.)

System version 4

One heating circuit without mixer A1, one heating circuit with mixer M2 and system separation

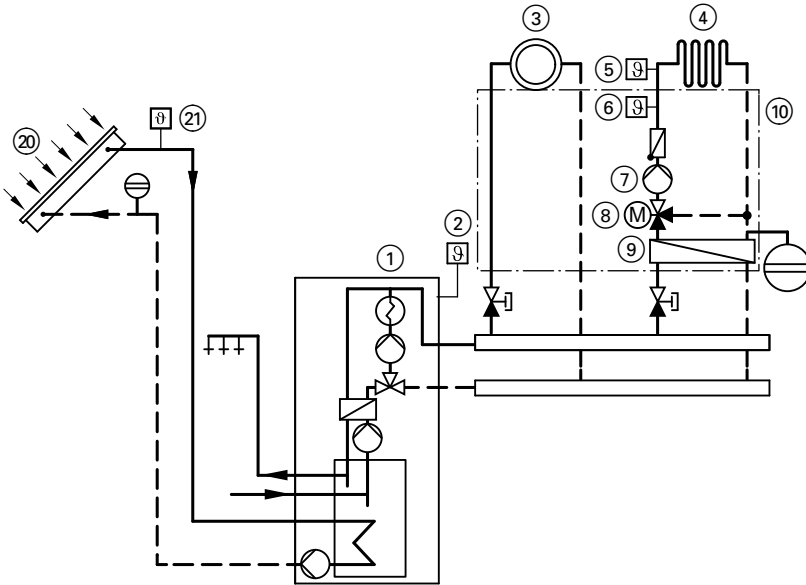

- ① Vitodens 242-F
- ② Outside temperature sensor
- ③ Heating circuit without mixer A1
- ④ Heating circuit with mixer M2
- ⑤ Temperature limiter for limiting the maximum temperature of underfloor heating systems
- ⑥ Flow temperature sensor M2
- ⑦ Heating circuit pump M2
- ⑧ Extension kit for one heating circuit with mixer M2
- ⑨ Heat exchanger for system separation
- ⑩ Construction kit with mixer (accessory)
- ⑳ Solar collectors
- ㉑ Collector temperature sensor

Required coding

Operation with LPG	82:1
--------------------	------

Further details regarding the individual steps (cont.)

System version 5

One heating circuit with mixer M1 (with Vitotronic 200-H), one heating circuit with mixer M2 (with extension kit) and low loss header (with/without DHW heating)

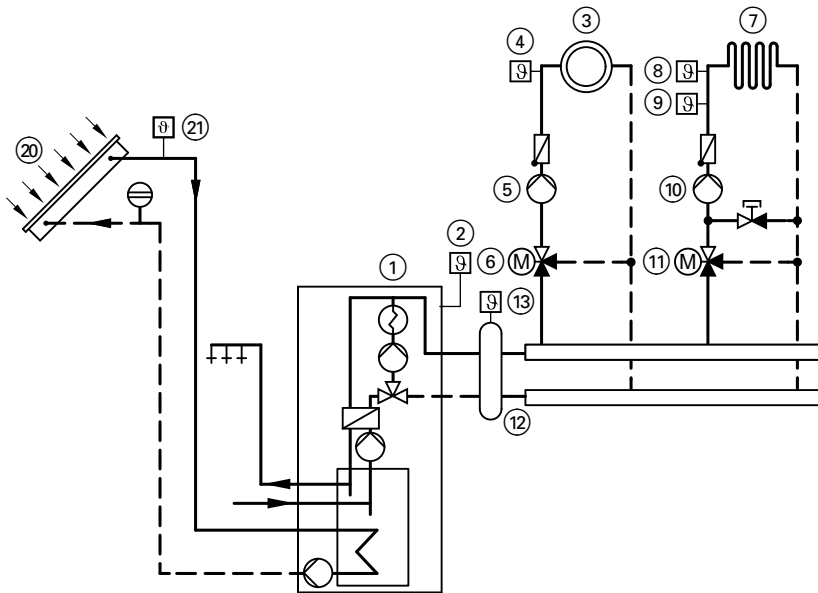

- | | |
|--|---|
| ① Vitodens 242-F | ⑨ Flow temperature sensor M2 |
| ② Outside temperature sensor | ⑩ Heating circuit pump M2 |
| ③ Heating circuit with mixer M1 | ⑪ Extension kit for one heating circuit with mixer M2 |
| ④ Flow temperature sensor M1 | ⑫ Low loss header |
| ⑤ Heating circuit pump M1 | ⑬ Flow temperature sensor, low loss header |
| ⑥ Vitotronic 200-H | ⑳ Solar collectors |
| ⑦ Heating circuit with mixer M2 | ㉑ Collector temperature sensor |
| ⑧ Temperature limiter for limiting the maximum temperature of underfloor heating systems | |

Required coding

Operation with LPG	82:1
System with only one heating circuit with mixer and DHW heating	00:4

Further details regarding the individual steps (cont.)

Adjusting the heating curves

The heating curves illustrate the relationship between the outside temperature and the boiler water or flow temperature.

To put it simply: The lower the outside temperature, the higher the boiler water or flow temperature.

The room temperature, again, depends on the boiler water or the flow temperature.

Settings in the delivered condition:

- Slope = 1.4
- Level = 0

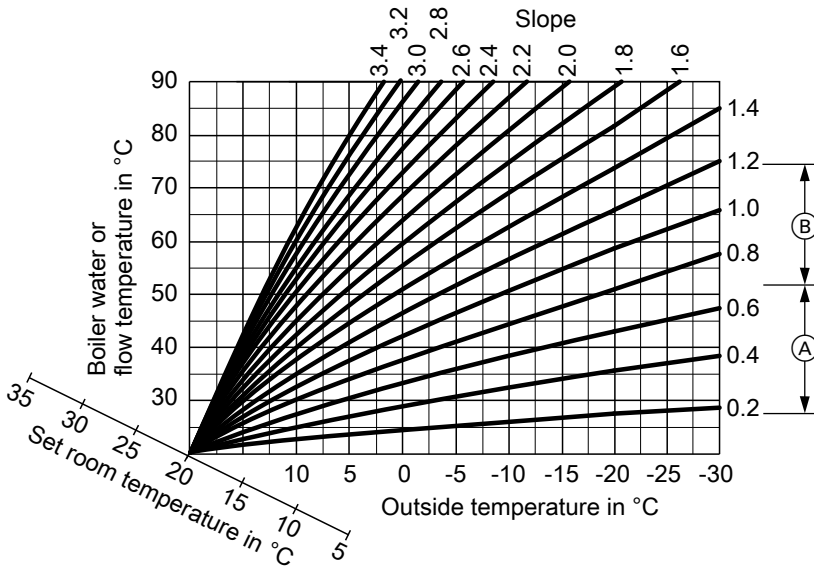

- (A) Heating curve slope for underfloor heating systems
- (B) Heating curve slope for low temperature heating systems (according to the Energy Savings Order [Germany])

Further details regarding the individual steps (cont.)

Changing the slope and level

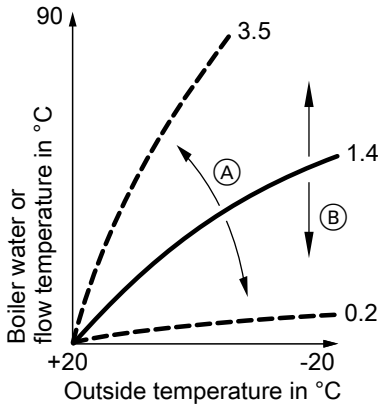

- (A) Changing the slope
- (B) Changing the level (vertical parallel offset of the heating curve)

Extended menu:

- 1.
2. "Heating"
3. Select a heating circuit: "HC1" or "HC2".
4. "Heating curve"
5. "Slope" or "Level"
6. Select heating curve according to the requirements of the system.

Adjusting the set room temperature

Standard room temperature

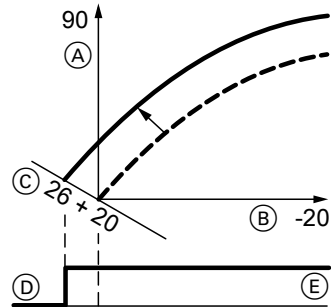

Example 1: Adjustment of the standard room temperature from 20 to 26°C

- (A) Boiler water temperature or flow temperature in °C
- (B) Outside temperature in °C
- (C) Set room temperature in °C
- (D) Heating circuit pump "OFF"
- (E) Heating circuit pump "ON"

Adjustment of the standard room temperature:

Operating instructions

Further details regarding the individual steps (cont.)

Reduced room temperature

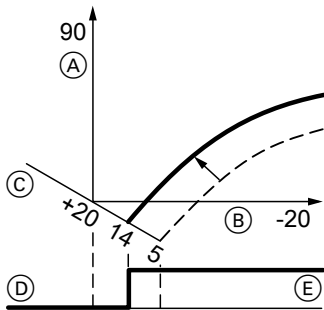

- (C) Set room temperature in °C
- (D) Heating circuit pump "OFF"
- (E) Heating circuit pump "ON"

Adjustment of the reduced room temperature:



Operating instructions

Example 2: Adjustment of the reduced room temperature from 5 °C to 14 °C

- (A) Boiler water temperature or flow temperature in °C
- (B) Outside temperature in °C

Connecting the control unit to the LON

The LON communication module (accessories) must be plugged in.



Installation instructions
LON communication module

Note

The data transfer via LON can take several minutes.

Single boiler system with Vitotronic 200-H and Vitocom 300 (example)

Set the LON subscriber numbers and further functions via code 2 (see the following table).

Note

In the same LON system, the same number **cannot** be allocated twice.

Only one Vitotronic may be programmed as fault manager.

Further details regarding the individual steps (cont.)

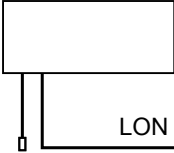
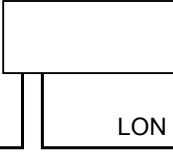
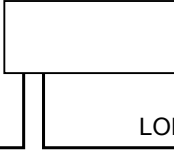
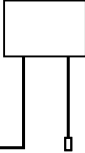
Boiler control unit	Vitotronic 200-H	Vitotronic 200-H	Vitocom
			
Subscriber no. 1 Code "77:1"	Subscriber no. 10 Code "77:10"	Subscriber no. 11 Set code "77:11"	Subscriber no. 99
Control unit is fault manager Code "79:1"	Control unit is not fault manager Code "79:0"	Control unit is not fault manager Code "79:0"	Device is fault manager
Control unit transmits the time Code "7b:1"	The control unit receives the time Set code "81:3"	The control unit receives the time Set code "81:3"	Device receives the time
Control unit transmits outside temperature Set code "97:2"	The control unit receives the outside temperature Set code "97:1"	The control unit receives the outside temperature Set code "97:1"	—
LON subscriber fault monitoring Code "9C:20"	LON subscriber fault monitoring Code "9C:20"	LON subscriber fault monitoring Code "9C:20"	—

Carrying out a LON subscriber check

Communication with the system devices connected to the fault manager is tested with a subscriber check.

Preconditions:

- The control unit must be programmed as **fault manager** (code "79:1")
- The LON subscriber number must be programmed in all control units (see page 57)
- The LON subscriber list in the fault manager must be up to date (see page 57)

2. "Service functions"

3. "Subscriber check"

Carrying out a subscriber check:

1. Press **OK** and  simultaneously for approx. 4 s.

Further details regarding the individual steps (cont.)

4. Select subscriber (e.g. subscriber 10).
The subscriber check for the selected subscriber is introduced.
 - Successfully tested subscribers are designated with **"OK"**.
 - Unsuccessfully tested subscribers are designated with **"Not OK"**.

Note

*To carry out a new subscriber check, create a new subscriber list with menu item **"Delete list?"***

Note

*If the subscriber check is carried out by another control unit, the subscriber number and **"Wink"** are shown on the display for approx. 1 min.*

Scanning and resetting the "Service" display

After the limit values specified in coding address "21" and "23" have been reached, "Service" and "🔧" appear on the programming unit display.

Scanning and resetting service

Press **OK** to acknowledge a service message.

Note

An acknowledged service message that was not reset reappears the following Monday.

After a service has been carried out (reset service)

1. Press **OK** and **≡** simultaneously for approx. 4 s.

2. "Service functions"

3. "Service reset"

Note

The selected service parameters for hours run and time interval restart at 0.

Further details regarding the individual steps (cont.)

Fitting the front panels

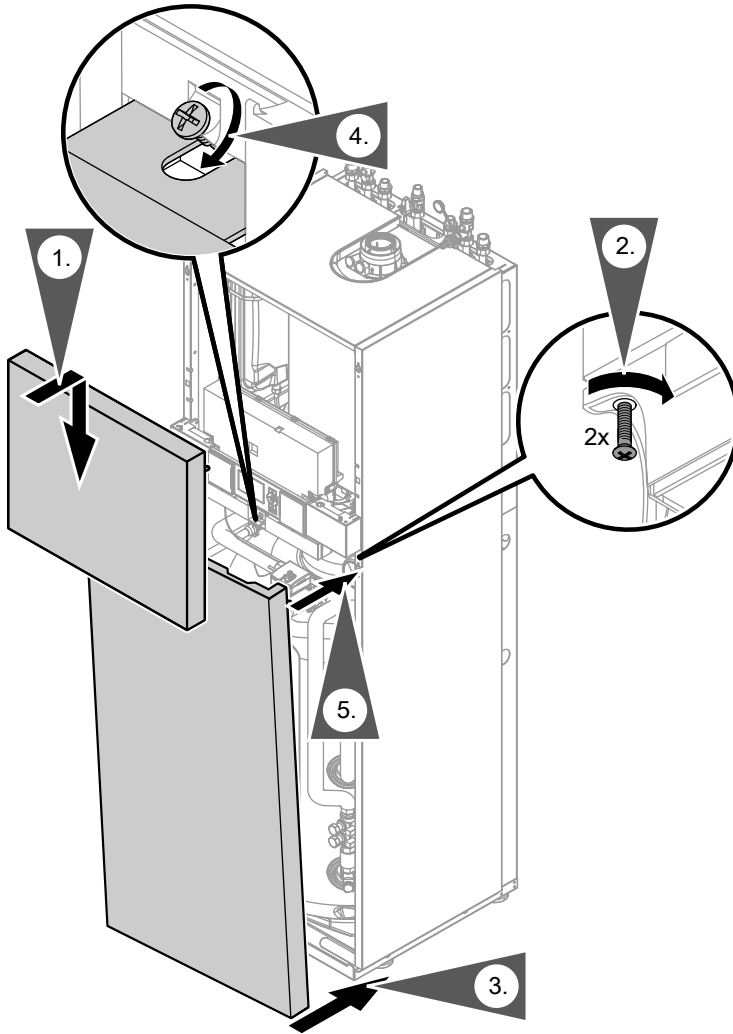

Further details regarding the individual steps (cont.)

Instructing the system user

The system installer must hand the operating instructions to the system user and instruct him/her in the operation of the system.

Calling up code 1

Note

- The codes are displayed as plain text.
- Codes that have no function due to the heating system equipment level or the setting of other codes are not displayed.
- Heating systems with one heating circuit without mixer and one heating circuit with mixer:
The heating circuit without mixer is designated with **"Heating circuit 1"** and the heating circuit with mixer with **"Heating circuit 2"**.
If the heating circuits were given individual designations (see page 28), the selected designation and **"HC1"** or **"HC2"** appear instead of the above.

1. Press **OK** and **≡** simultaneously for approx. 4 s.

2. "Coding level 1"

3. Select group of required coding address:
 - "General"
 - "Boiler"
 - "DHW"
 - "Solar"
 - "Heating circuit 1/heating circuit 2"
4. Select coding address.
5. Select value according to the following tables and confirm with **OK**.
6. **If you want to reset all codes to the delivered condition:**
Select **"Standard setting"** in **"Coding level 1"**.

General

Coding

Coding in the delivered condition		Possible change	
System design			
00:2	System version 1: One heating circuit without mixer A1, with DHW heating	00:4	System version 2, 5: One heating circuit with mixer M2, with DHW heating
		00:6	System version 3, 4: One heating circuit without mixer A1 and one heating circuit with mixer M2, with DHW heating

General (cont.)

Coding in the delivered condition		Possible change	
Internal circulation pump function			
51:0	Internal circulation pump is always started when there is a heat demand	51:1	When there is a heat demand, the internal circulation pump will only be started when the burner is operational. System with heating water buffer cylinder
User no.			
77:1	LON user number	77:2 to 77:99	LON subscriber number, adjustable from 1 to 99: 1 - 4 = Boiler 5 = Cascade 10 - 98 = Vitotronic 200-H 99 = Vitocom Note <i>Allocate each number only once</i>
Detached house/apartment building			
7F:1	Detached house	7F:0	Apartment building Separate adjustment of holiday program and time program for DHW heating, as option
Lock out controls			
8F:0	All control elements active	8F:1	All control elements locked out Only setting test mode possible
		8F:2	Standard menu and test mode enabled Extended menu locked out

General (cont.)

Coding in the delivered condition		Possible change	
Ext. Heating program changeover to heating circuit			
91:0	No external heating program changeover via external extension	91:1	The external heating program changeover affects the heating circuit without mixer
		91:2	The external heating program changeover affects the heating circuit with mixer
		91:3	The external heating program changeover affects the heating circuit without mixer and the heating circuit with mixer
Set flow temperature in case of ext. demand			
9b:0	No minimum flow temperature in case of external demand	9b:1 to 9b:127	Set value for minimum flow temperature in case of external demand, adjustable from 1 to 127 °C (limited by boiler-specific parameters)

Boiler**Coding**

Coding in the delivered condition		Possible change	
Burner service in 100 hours			
21:0	No maintenance interval (hours run) selected	21:1 to 21:100	The number of hours run before the burner should be serviced is adjustable from 100 to 10 000 h One adjusting step $\hat{=}$ 100 h
Service interval in months			
23:0	No time interval for burner service	23:1 to 23:24	Interval adjustable from 1 to 24 months



Boiler (cont.)

Coding in the delivered condition		Possible change	
Service status			
24:0	No "Service" display	24:1	"Service" display (the address is automatically set and must be manually reset after a service has been carried out)
Filling/venting			
2F:0	Venting program/fill program disabled	2F:1	Venting program enabled
		2F:2	Fill program enabled
Ext. pump blocking			
32:0	Influence of the signal "External blocking" on circulation pumps: All pumps in control function	32:1 to 32:15	Influence of the signal "External blocking" on circulation pumps: See the following table

Note

Generally, the burner will be blocked when signal "External blocking" is enabled.

Value address 32: ...	Internal circulation pump	Heating circuit pump Heating circuit without mixer	Heating circuit pump Heating circuit with mixer	Circulation pump for cylinder heating
0	Control funct.	Control funct.	Control funct.	Control funct.
1	Control funct.	Control funct.	Control funct.	OFF
2	Control funct.	Control funct.	OFF	Control funct.
3	Control funct.	Control funct.	OFF	OFF
4	Control funct.	OFF	Control funct.	Control funct.
5	Control funct.	OFF	Control funct.	OFF
6	Control funct.	OFF	OFF	Control funct.
7	Control funct.	OFF	OFF	OFF
8	OFF	Control funct.	Control funct.	Control funct.
9	OFF	Control funct.	Control funct.	OFF
10	OFF	Control funct.	OFF	Control funct.
11	OFF	Control funct.	OFF	OFF
12	OFF	OFF	Control funct.	Control funct.
13	OFF	OFF	Control funct.	OFF
14	OFF	OFF	OFF	Control funct.
15	OFF	OFF	OFF	OFF

Boiler (cont.)

Coding in the delivered condition		Possible change	
Ext. pump demand			
34:0	Influence of the signal "External demand" on the circulation pumps: All pumps in control function	34:1 to 34:23	Influence of the signal "External demand" on the circulation pumps: See the following table

Value address 34: ...	Internal circulation pump	Heating circuit pump Heating circuit without mixer	Heating circuit pump Heating circuit with mixer	Circulation pump for cylinder heating
0	Control funct.	Control funct.	Control funct.	Control funct.
1	Control funct.	Control funct.	Control funct.	OFF
2	Control funct.	Control funct.	OFF	Control funct.
3	Control funct.	Control funct.	OFF	OFF
4	Control funct.	OFF	Control funct.	Control funct.
5	Control funct.	OFF	Control funct.	OFF
6	Control funct.	OFF	OFF	Control funct.
7	Control funct.	OFF	OFF	OFF
8	OFF	Control funct.	Control funct.	Control funct.
9	OFF	Control funct.	Control funct.	OFF
10	OFF	Control funct.	OFF	Control funct.
11	OFF	Control funct.	OFF	OFF
12	OFF	OFF	Control funct.	Control funct.
13	OFF	OFF	Control funct.	OFF
14	OFF	OFF	OFF	Control funct.
15	OFF	OFF	OFF	OFF
16	ON	Control funct.	Control funct.	Control funct.
17	ON	Control funct.	Control funct.	OFF
18	ON	Control funct.	OFF	Control funct.
19	ON	Control funct.	OFF	OFF
20	ON	OFF	Control funct.	Control funct.
21	ON	OFF	Control funct.	OFF
22	ON	OFF	OFF	Control funct.
23	ON	OFF	OFF	OFF

DHW

Coding

Coding in the delivered condition		Possible change	
Set DHW temperature with reheating suppression			
67:40	Subject to the current output of the solar thermal system, DHW heating is started by the boiler between 40 °C actual cylinder temperature and set cylinder temperature.	67:0	Function switched off
		67:1 to 67:95	Start point adjustable from 1 to 95 °C
Enable DHW circulation pump			
73:0	DHW circulation pump "ON" according to time program	73:1 to 73:6	During the time program 1x/h "ON" for 5 min up to 6x/h "ON" for 5 min
		73:7	Constantly "On"

Solar

Coding

Coding in the delivered condition		Possible change	
Maximum cylinder temperature			
08:60	The solar circuit pump will be switched off when the actual cylinder temperature reaches 60 °C (maximum cylinder temperature).	08:10 to 08:90	The maximum cylinder temperature can be adjusted from 10 to 90 °C
Reducing stagnation time			
0A:5	To protect the system components and heat transfer medium, the speed of the solar circuit pump is reduced when the differential between the actual cylinder temperature and set cylinder temperature is less than 5 K.	0A:0 to 0A:40	The differential between the set cylinder temperature and the start point for reducing the stagnation time can be adjusted from 0 to 40 K.

Solar (cont.)

Coding in the delivered condition		Possible change	
Flow rate			
0F:70	The flow rate in the collector circuit at the maximum pump speed is set to 7 l/min.	0F:1 to 0F:255	Flow rate in the collector circuit adjustable from 0.1 to 25.5 l/min

Heating circuit 1/heating circuit 2

Coding

Coding in the delivered condition		Possible change	
Summer eco function outside temperature			
A5:5	With heating circuit pump logic function (economy circuit): Heating circuit pump "Off" when the outside temperature (AT) is 1 K higher than the set room temperature (RT_{set}) $AT > RT_{set} + 1 K$	A5:0	Without heating circuit pump logic function
		A5:1 to A5:15	With heating circuit pump logic function: Heating circuit pump "OFF" (see the following table)

Parameter address	With heating circuit pump logic function: Heating circuit pump "OFF"
A5:...	
1	$AT > RT_{set} + 5 K$
2	$AT > RT_{set} + 4 K$
3	$AT > RT_{set} + 3 K$
4	$AT > RT_{set} + 2 K$
5	$AT > RT_{set} + 1 K$
6	$AT > RT_{set}$
7	$AT > RT_{set} - 1 K$
to	
15	$AT > RT_{set} - 9 K$

Heating circuit 1/heating circuit 2 (cont.)

Coding in the delivered condition		Possible change	
Summer eco function absolute			
A6:36	Extended economy mode disabled	A6:5 to A6:35	Extended economy control enabled, i.e. the burner and heating circuit pump will be switched off and the mixer closed at a variable value, adjustable between 5 and 35 °C plus 1 °C. Base value is the adjusted outside temperature. This value is based on the actual outside temperature and a time constant that takes the cooling down of an average building into consideration.
Mixer economy function			
A7:0	Without mixer economy function (only for heating circuits with mixer)	A7:1	With mixer economy function (extended heating circuit pump logic): Heating circuit pump also "OFF": <ul style="list-style-type: none"> ■ If the mixer has been closed for longer than 20 min. Heating pump "ON": <ul style="list-style-type: none"> ■ If the mixer changes to control function ■ If there is a risk of frost
Pump idle time change red. mode			
A9:7	With pump idle time: Heating circuit pump "OFF" in case of set value modification by changing the operating mode or changing the set room temperature	A9:0 A9:1 to A9:15	Without pump idle time With pump idle time; adjustable from 1 to 15

Heating circuit 1/heating circuit 2 (cont.)

Coding in the delivered condition		Possible change	
Weather-compensated/ room temperature hook-up			
b0:0	With remote control: Heating mode/reduced mode: (change code only for heating circuit with mixer M2)	b0:1	Heating mode: weather-compensated Reduc. mode: with room temperature hook-up
		b0:2	Heating mode: with room temperature hook-up Reduc. mode: weather-compensated
		b0:3	Heating mode/reduced mode: with room temperature hook-up

Summer eco function room temperature

b5:0	With remote control: No room temperature-dependent heating circuit pump logic function (change the code only for heating circuit with mixer M2)	b5:1 to b5:8	Heating circuit pump logic function, see the following table:
------	---	--------------	---

Parameter address b5:...	With heating circuit pump logic function:	
	Heating circuit pump "OFF"	Heating circuit pump "ON"
1	$RT_{\text{actual}} > RT_{\text{set}} + 5 \text{ K}$	$RT_{\text{actual}} < RT_{\text{set}} + 4 \text{ K}$
2	$RT_{\text{actual}} > RT_{\text{set}} + 4 \text{ K}$	$RT_{\text{actual}} < RT_{\text{set}} + 3 \text{ K}$
3	$RT_{\text{actual}} > RT_{\text{set}} + 3 \text{ K}$	$RT_{\text{actual}} < RT_{\text{set}} + 2 \text{ K}$
4	$RT_{\text{actual}} > RT_{\text{set}} + 2 \text{ K}$	$RT_{\text{actual}} < RT_{\text{set}} + 1 \text{ K}$
5	$RT_{\text{actual}} > RT_{\text{set}} + 1 \text{ K}$	$RT_{\text{actual}} < RT_{\text{set}}$
6	$RT_{\text{actual}} > RT_{\text{set}}$	$RT_{\text{actual}} < RT_{\text{set}} - 1 \text{ K}$
7	$RT_{\text{actual}} > RT_{\text{set}} - 1 \text{ K}$	$RT_{\text{actual}} < RT_{\text{set}} - 2 \text{ K}$
8	$RT_{\text{actual}} > RT_{\text{set}} - 2 \text{ K}$	$RT_{\text{actual}} < RT_{\text{set}} - 3 \text{ K}$

Coding in the delivered condition		Possible change	
Flow temperature minimum limit			
C5:20	Electronic minimum flow temperature limit 20 °C	C5:1 to C5:127	Minimum limit adjustable from 1 to 127 °C (limited by boiler-specific parameters)

Heating circuit 1/heating circuit 2 (cont.)

Coding in the delivered condition		Possible change	
Flow temperature maximum limit			
C6:74	Electronic maximum flow temperature limit set to 74 °C	C6:10 to C6:127	Maximum limit adjustable from 10 to 127 °C (limited by boiler-specific parameters)
Heating program changeover			
d5:0	External heating program changeover changes to "Constant operation with reduced room temperature"	d5:1	The external heating program changeover changes to "Constant operation with standard room temperature"
Max. pump speed in standard mode			
E6:65	Maximum speed of the variable speed heating circuit pump: 65 % of the maximum speed	E6:0 to E6:100	Maximum speed adjustable from 0 to 100%
Min. pump speed			
E7:30	Minimum speed of the variable speed heating circuit pump: 30 %	E7:0 to E7:100	Minimum speed adjustable from 0 to 100% of the maximum speed
Screed function			
F1:0	Screed function disabled	F1:1 to F1:6	Screed drying function adjustable in accordance with 6 optional temperature/time profiles (see page 114)
		F1:15	Constant flow temperature 20 °C
Party mode time limit			
F2:8	Time limit for party mode or external heating program changeover via key: 8 h ^{*1}	F2:0	No time limit for party mode ^{*1}
		F2:1 to F2:12	Time limit adjustable from 1 to 12h ^{*1}

^{*1} Party mode ends **automatically** in the "Heating and DHW" program, when the system changes over to operation with standard room temperature.

Heating circuit 1/heating circuit 2 (cont.)

Coding in the delivered condition		Possible change	
Start temperature raising			
F8:-5	Temperature limit for terminating the reduced mode -5 °C, see example on page 116. Observe the setting of coding address "A3".	F8:+10 to F8:-60	Temperature limit adjustable from +10 to -60 °C
		F8:-61	Function disabled
End temperature raising			
F9:-14	Temperature limit for raising the reduced set room temp. -14 °C, see example on page 116.	F9:+10 to F9:-60	Temperature limit for raising the set room temperature to the value selected for standard mode adjustable from +10 to -60 °C
Increase set flow temperature			
FA:20	Raising the set boiler water temperature or the set flow temperature when changing from operation with reduced room temperature to operation with standard room temperature, by 20 %. See example on page 117.	FA:0 to FA:50	Temperature rise adjustable from 0 to 50 %
Duration set flow temperature increase			
Fb:30	Duration for raising the set boiler water temperature or the set flow temperature (see coding address "FA") 60 min. See example on page 117.	Fb:0 to Fb:150	Duration adjustable from 0 to 300 min; 1 step \cong 2 min

Calling up coding level 2

Note



- In coding level 2, all codes are accessible, including the codes from coding level 1.

The following lists only those codes not accessible in coding level 1.

- Codes that have no function due to the heating system equipment level or the setting of other codes are not displayed.
- Heating systems with one heating circuit without mixer and one heating circuit with mixer:

The heating circuit without mixer is designated with "**Heating circuit 1**" and the heating circuit with mixer with "**Heating circuit 2**".

If the heating circuits were given individual designations (see page 28), the selected designation and "**HC1**" or "**HC2**" appears instead of the above.

1. Press **OK** and  simultaneously for approx. 4 s.
2. Press **OK** and  simultaneously for approx. 4 s.

3. "Coding level 2"

4. Select group of required coding address:
 - "**General**"
 - "**Boiler**"
 - "**DHW**"
 - "**Solar**"
 - "**Heating circuit 1/heating circuit 2**"
5. Select coding address.
6. Select value according to the following tables and confirm with "**OK**".
7. **If you want to reset all codes to the delivered condition:**
Select "**Standard setting**" in "**Coding level 2**".

Note

The codes from coding level 1 are also reset.

General

Coding

Coding in the delivered condition		Possible change	
11:≠9	No access to the coding addresses for the parameters of the combustion controller	11:9	Access open to the coding addresses for the parameters of the combustion controller
52:0	Without flow temperature sensor for low loss header	52:1	With flow temperature sensor for low loss header (automatic recognition)
54:3	Never adjust		

General (cont.)

Coding in the delivered condition		Possible change	
6E:50	Never adjust		
76:0	Without LON communication module	76:1	With LON communication module (automatic recognition)
79:1	With LON communication module: Control unit is fault manager	79:0	Control unit is not fault manager
7b:1	With LON communication module: Control unit transmits the time	7b:0	Do not transmit time
80:6	A fault message is displayed, providing a fault is active for at least 5 s	80:0	Immediate fault message
		80:2 to 80:199	The minimum fault duration before a fault message is issued is adjustable from 10 s to 995 s; 1 step \triangleq 5 s
81:1	Automatic summer/winter time changeover	81:0	Manual summer/winter time changeover
		81:2	Use of the radio clock receiver (automatic recognition)
		81:3	With LON communication module: The control unit receives the time
82:0	Operation with natural gas	82:1	Operation with LPG (only adjustable if coding address 11:9 has been set)
86:0	Never adjust		
87:0	Never adjust		
88:0	Temperature displayed in °C (Celsius)	88:1	Temperature displayed in °F (Fahrenheit)
8A:175	Do not adjust		
90:128	Time constant for calculating the adjusted outside temperature 21.3 h	90:1 to 90:199	Fast (low values) or slow (high values) matching of the flow temperature, subject to the set value when the outside temperature changes; 1 step \triangleq 10 min



General (cont.)

Coding in the delivered condition		Possible change	
94:0	Without Open Therm extension	94:1	With Open Therm extension (automatic recognition)
95:0	Without Vitocom 100 communication interface	95:1	With Vitocom 100 communication interface (automatic recognition)
97:0	With LON communication module: The outside temperature of the sensor connected to the control unit is utilised internally	97:1	The control unit receives the outside temperature
		97:2	The control unit sends the outside temperature to the Vitotronic 200-H
98:1	Viessmann system number (in conjunction with monitoring several systems via Vitocom 300)	98:1 to 98:5	System number adjustable from 1 to 5
9C:20	Monitoring LON subscribers. If a subscriber fails to respond, the values specified inside the control unit will be used after 20 min. Only then will a fault message be issued.	9C:0	No monitoring
		9C:5 to 9C:60	The time is adjustable from 5 to 60 min
9F:8	Differential temperature 8 K; only in conjunction with mixer circuit	9F:0 to 9F:40	Differential temperature adjustable from 0 to 40 K

Boiler**Coding**

Coding in the delivered condition		Possible change	
06:...	Maximum limit of the boiler water temperature, specified in °C by the boiler coding card	06:20 to 06:127	Maximum limit of the boiler water temperature within the ranges specified by the boiler
12:0	Never adjust		

Boiler (cont.)

Coding in the delivered condition		Possible change	
28:0	No burner interval ignition	28:1 to 28:24	Time interval adjustable from 1 to 24 h. The burner is force-started once every 30 s (only when operating with LPG).
2E:0	Without external extension	2E:1	With external extension (automatic recognition)
30:0	Never adjust		
31:...	Set speed of the internal circulation pump when operated as boiler circuit pump %, specified by the boiler coding card	31:0 to 31:100	Set speed adjustable from 0 to 100 %
38:0	Status burner control unit: Operational (no fault)	38:≠0	Status burner control unit: Fault

DHW**Coding**

Coding in the delivered condition		Possible change	
DHW			
56:0	Set DHW temperature adjustable from 10 to 60 °C	56:1	Set DHW temperature adjustable from 10 to above 60 °C Note <i>Maximum value subject to boiler coding card. Observe the max. permissible DHW temperature.</i>
58:0	Without auxiliary function for DHW heating	58:10 to 58:60	Input of a second set DHW temperature, adjustable from 10 to 60 °C (observe coding addresses "56" and "63")

DHW (cont.)

Coding in the delivered condition		Possible change	
65:...	Information regarding the type of diverter valve; do not adjust. <ul style="list-style-type: none"> ■ 65:0 No diverter valve ■ 65:1 Viessmann diverter valve ■ 65:2 Wilo diverter valve ■ 65:3 Grundfos diverter valve 		
6C:100	Set speed; internal primary pump for DHW heating 100 %. Never adjust.		
71:0	DHW circulation pump "ON" according to time program	71:1	"OFF" during DHW heating to the first set value
		71:2	"ON" during DHW heating to the first set value
72:0	DHW circulation pump "ON" according to time program	72:1	"OFF" during DHW heating to the second set value
		72:2	"ON" during DHW heating to the second set value

Solar**Coding**

Coding in the delivered condition		Possible change	
Solar			
00:8	The solar circuit pump starts when the collector temperature exceeds the actual cylinder temperature by 8 K.	00:2 to 00:30	The differential between the actual cylinder temperature and the start point for the solar circuit pump can be adjusted from 2 to 30 K.

Solar (cont.)

Coding in the delivered condition		Possible change	
01:4	The solar circuit pump is stopped when the differential between the collector temperature and the actual cylinder temperature is less than 4 K.	01:1 to 01:29	The differential between the actual cylinder temperature and the stop point for the solar circuit pump can be adjusted from 1 to 29 K.
02:2	Solar circuit pump with wave pack control	02:0	Solar circuit pump without variable speed (e.g. temporarily for service)
		02:1	Do not adjust
03:10	The temperature differential between the collector temperature and actual cylinder temperature is regulated to 10 K.	03:5 to 03:20	The differential between the collector temperature and actual cylinder temperature can be adjusted from 5 to 20 K.
04:5	Controller amplification of the speed control 5%/K.	04:1 to 04:10	Controller amplification adjustable from 1 to 10%/K
05:10	Minimum speed of the solar circuit pump 10% of the maximum speed	05:1 to 05:100	Minimum speed of the solar circuit pump is adjustable from 1 to 100%
06:80	Maximum speed of the solar circuit pump 80% of the maximum possible speed	06:1 to 06:100	Maximum speed of the solar circuit pump is adjustable from 1 to 100%
07:0	Interval function of the solar circuit pump switched off	07:1	Interval function of the solar circuit pump switched on. To capture the collector temperature more accurately, the solar circuit pump is started for short cycles.
09:130	The solar circuit pump will be switched off when the collector temperature reaches 130 °C (maximum collector temperature).	09:20 to 09:200	The maximum collector temperature can be adjusted from 20 to 200 °C



Solar (cont.)

Coding in the delivered condition		Possible change	
0b:0	Collector frost protection function switched off	0b:1	Collector frost protection function switched on (not required with Viessmann heat transfer medium).
0C:1	Delta T monitoring switched on. No flow rate captured in the collector circuit, or flow rate too low.	0C:0	Delta T monitoring switched off.
0d:1	Night DHW circulation monitoring switched on. Unintentional flow rate is captured in the collector circuit (e.g. at night).	0d:0	Night DHW circulation monitoring switched off.
0E:1	Function check solar yield with Viessmann heat transfer medium	0E:2	Function check solar yield with heat transfer medium water (do not adjust)
		0E:0	Function check solar yield switched off

Heating circuit 1/heating circuit 2**Coding**

Coding in the delivered condition		Possible change	
A0:0	Without remote control	A0:1	With Vitotrol 200 (automatic recognition)
		A0:2	With Vitotrol 300 or control via Vitohome 200 (automatic recognition)
A3:2	Outside temperature below 1 °C: Heating circuit pump "ON" Outside temperature above 3 °C: Heating circuit pump "OFF"	A3:9 to A3:15	Heating circuit pump "ON/OFF" (see the following table)

Heating circuit 1/heating circuit 2 (cont.)



Please note

If a value is selected below 1 °C, there is a risk of pipes outside the thermal envelope of the building freezing up.
The standby mode, in particular, should be taken into consideration, e.g. during holidays.

Parameters Address A3:...	Heating circuit pump	
	"ON"	"OFF"
-9	-10 °C	-8 °C
-8	-9 °C	-7 °C
-7	-8 °C	-6 °C
-6	-7 °C	-5 °C
-5	-6 °C	-4 °C
-4	-5 °C	-3 °C
-3	-4 °C	-2 °C
-2	-3 °C	-1 °C
-1	-2 °C	0 °C
0	-1 °C	1 °C
1	0 °C	2 °C
2	1 °C	3 °C
to	to	to
15	14 °C	16 °C

Coding in the delivered condition		Possible change	
A4:0	With frost protection	A4:1	No frost protection; this setting is only possible if code "A3: -9" has been selected. Note <i>Observe the information regarding coding address "A3"</i>
A8:1	Heating circuit with mixer creates a demand for the internal circulation pump	A8:0	Heating circuit with mixer creates no demand for the internal circulation pump

Heating circuit 1/heating circuit 2 (cont.)

Coding in the delivered condition		Possible change	
b2:8	With remote control and for the heating circuit, operation with room temperature hook-up must be programmed: Room influence factor 8 (change code only for heating circuit with mixer)	b2:0	Without room influence
		b2:1 to b2:64	Room influence factor adjustable from 1 to 64
d3:14	Heating curve slope = 1.4	d3:2 to d3:35	Heating curve slope adjustable from 0.2 to 3.5 (see page 54)
d4:0	Heating curve level = 0	d4:-13 to d4:40	Heating curve level adjustable from -13 to 40 (see page 54)
E1:1	With remote control: Set value for standard room temperature adjustable at the remote control from 10 to 30 °C	E1:0	Set value for standard room temperature, adjustable from 3 to 23 °C
		E1:2	Set value for standard room temperature, adjustable from 17 to 37 °C
E2:50	With remote control: No display correction of the actual room temperature	E2:0 to E2:49	Display correction -5 K to Display correction -0.1 K
		E2:51 to E2:99	Display correction +0.1 K to Display correction +4.9 K
E5:0	Without external, variable speed heating circuit pump	E5:1	With external variable speed heating circuit pump (automatic recognition)
E8:1	Minimum speed in operation with reduced room temperature subject to the setting of coding address "E9"	E8:0	Speed subject to the setting in coding address "E7"
E9:45	Speed of the variable speed heating circuit pump: 45% of the maximum speed in operation with reduced room temperature	E9:0 to E9:100	Speed adjustable from 0 to 100% of the maximum speed during operation with reduced room temperature

Diagnosis

Operating data can be scanned in the following areas:

- General
- Heating circuit 1
- Heating circuit 2 (if heating circuit with mixer installed)
- DHW
- Solar
- Brief scan (for further information, see page 81)
- Reset data

Note

If a sensor that has been scanned is not connected, "- - -" appears on the display.

Calling up operating data

1. Press **OK** and **≡**: simultaneously for approx. 4 s.
2. "Diagnosis"
3. Select required group, e.g. "General".

Resetting operating data

Saved operating data (e.g. hours run) can be reset to 0.
The value "Adjusted outside temp" is reset to the actual value.

1. Press **OK** and **≡**: simultaneously for approx. 4 s.
2. "Diagnosis"
3. "Reset data"

Brief scan

In the brief scan, you can scan temperatures, software versions and connected components, for example.

1. Press **OK** and **≡**: simultaneously for approx. 4 s.
2. "Diagnosis"
3. "Brief scan".
4. Press **OK**.
The display shows 8 lines with 6 fields each.

Diagnosis (cont.)

Diagnose Kurzabfrage						
1:	1	F	0	A	1	2
2:	0	0	0	0	0	0
3:	0	0	0	0	0	0
4:	0	0	0	0	0	0

Wählen mit

For an explanation of the relevant values in the individual lines, see the following table:

Line (brief scan)	Field					
	1	2	3	4	5	6
1:	Software version Control unit		Equipment version		Burner control unit version	
2:	System designs 01 to 06		Number of KM BUS users	Maximum demand temperature		
3:	0	Software version Programming unit	Software version Mixer extension 0: no mixer extension	0	Software version LON module	Software version External extension 0: no external extension
4:	Software version Burner control unit		Type Burner control unit		Appliance type	
5:	0: no external demand 1: external demand	0: no external blocking 1: external blocking	0	External 0 to 10 V hook-up Display in °C 0: no external hook-up		
6:	Number of LON subscribers		Check digit	Max. output Details in %		

Diagnosis (cont.)

Line (brief scan)	Field					
	1	2	3	4	5	6
	Boiler		Heating circuit A1 (without mixer)		Heating circuit with mixer M2	
7:	0	0	Remote control 0 w/o 1 Vitotrol 200 2 Vitotrol 300	Software version Remote control 0: no remote control	Remote control 0 w/o 1 Vitotrol 200 2 Vitotrol 300	Software version Remote control 0: no remote control
	Internal circulation pump		Heating circuit pump to connection extension			
8:	0	0	Variable speed pump 0 w/o 1 Wilo 2 Grundfos	Software version Variable speed pump 0: no variable speed pump	Variable speed pump 0 w/o 1 Wilo 2 Grundfos	Software version Variable speed pump 0: no variable speed pump

Checking outputs (relay test)

1. Press **OK** and  simultaneously for approx. 4 s.
2. "Actuator test"

The following relay outputs can be controlled subject to system design:

Display	Explanation
Base load	Burner modulation base load
Full load	Burner modulation full load
Internal pump ON	Int. output 20
Htg. system valve	Diverter valve set to heating mode
Valve Centre	Diverter valve in central position (filling/draining)
Valve Cylinder	Diverter valve set to DHW mode
Heating circ pump M2 ON	Extension heating circuit with mixer
Mix.valve open	Extension heating circuit with mixer
Mix.valve closed	Extension heating circuit with mixer



Checking outputs (relay test) (cont.)

Display	Explanation
Output internal ON	Output 28 Internal extension
Heating circ pump A1 ON	Connection to external extension H1
Cyl. prim. pump ON	Connection to external extension H1
DHW circ pump ON	Connection to external extension H1
Central fault ON	Connection to external extension H1
Solar circuit pump ON	Solar circuit pump output on solar control module active
Solar circ pmp min ON	Solar circuit pump output on solar control module switched to minimum speed
Solar circ pmp max ON	Output solar circuit pump on solar control module switched to maximum speed

Fault display

If there is a fault, the red fault indicator **(A)** flashes. "**Δ**" flashes on the display and "**Fault**" is shown.

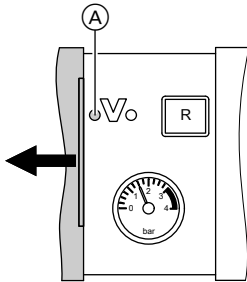

The fault code is displayed with **OK**. For an explanation of the fault code, see the following pages.

For some faults, the type of fault is also displayed in plain text.

Acknowledging a fault

Follow the instructions on the display.

Note

*Fault indicator **(A)** continues to flash. The fault message goes into the standard display of the short menu.*

A fault messaging facility, if connected, will be switched off.

If an acknowledged fault is not remedied, the fault message will be re-displayed the following day.

Calling up acknowledged faults

Select "**Fault**" in the standard menu. The current faults will be displayed in a list.

Calling up fault codes from the fault memory (fault history)

The 10 most recent faults (including resolved ones) are saved and can be scanned.

Faults are sorted by date.

1. Press **OK** and **≡** simultaneously for approx. 4 s.
2. "**Fault history**"
3. "**Display?**"

Fault codes

Fault code on the display	System characteristics	Cause	Measures
10	Controls as if the outside temperature were 0 °C	Short circuit, outside temperature sensor	Check the outside temperature sensor (see page 95)
18	Controls as if the outside temperature were 0 °C	Lead break, outside temperature sensor	Check the outside temperature sensor (see page 95)
20	Regulates without flow temperature sensor (low loss header)	Short circuit, system flow temperature sensor	Check the low loss header sensor (see page 96)
28	Regulates without flow temperature sensor (low loss header)	Lead break, system flow temperature sensor	Check the low loss header sensor (see page 96)
30	Burner blocked	Short circuit, boiler water temperature sensor	Check the boiler water temperature sensor (see page 96)
38	Burner blocked	Lead break, boiler water temperature sensor	Check the boiler water temperature sensor (see page 96)
40	Mixer closes	Short circuit, flow temperature sensor, heating circuit 2 (with mixer)	Check flow temperature sensor
48	Mixer closes	Lead break, flow temperature sensor, heating circuit 2 (with mixer)	Check flow temperature sensor
50	No DHW heating	Short circuit, cylinder temperature sensor	Check sensors (see page 96)
51	No DHW heating	Short circuit, outlet temperature sensor	Check sensors (see page 96)
58	No DHW heating	Lead break, cylinder temperature sensor	Check sensors (see page 96)

Fault codes (cont.)

Fault code on the display	System characteristics	Cause	Measures
59	No DHW heating	Lead break, outlet temperature sensor	Check sensors (see page 96)
92	No DHW heating	Short circuit, collector temperature sensor; connection to the solar control module	Check sensor 6 on the solar control module.
94	No DHW heating	Short circuit, cylinder temperature sensor; connection to the solar control module	Check sensor 5 on the solar control module.
9A	No DHW heating	Lead break, collector temperature sensor; connection to the solar control module	Check sensor 6 on the solar control module.
9C	No DHW heating	Lead break, cylinder temperature sensor; connection to the solar control module	Check sensor 5 on the solar control module.
9E	Control mode	No flow rate in the collector circuit or flow rate too low, or temperature limiter has responded	Check solar circuit pump and solar circuit. Acknowledge fault message.
9F	Control mode	Solar control module fault	Check solar control module
A7	Control mode as per delivered condition	Faulty programming unit	Replace programming unit
A8	Burner blocked The venting program is started automatically (see page 61)	Air lock in the internal circulation pump or minimum flow rate not achieved	Vent the system if the fault message continues to be displayed



Fault codes (cont.)

Fault code on the display	System characteristics	Cause	Measures
A9	The burner operates at its lower output if a heating circuit with mixer is connected. The burner is blocked if only one heating circuit without mixer is connected.	Internal circulation pump blocked	Check the circulation pump
b0	Burner blocked	Short circuit, flue gas temperature sensor	Checking the flue gas temperature sensor
b1	Control mode as per delivered condition	Communication error, programming unit	Check connections and replace the programming unit, if required
b4	Controls as if the outside temperature were 0 °C	Internal fault	Replacing the control unit
b5	Control mode as per delivered condition	Internal fault	Replacing the control unit
b7	Burner blocked	Boiler coding card fault	Plug in boiler coding card or replace, if faulty
b8	Burner blocked	Lead break, flue gas temperature sensor	Checking the flue gas temperature sensor
bA	Mixer regulates to 20 °C flow temperature.	Communication error, extension kit for heating circuit 2 (with mixer)	Check the extension kit connections and coding
bC	Control mode without remote control	Communication error, remote control Vitotrol heating circuit 1 (without mixer)	Check connections, cable, coding address "A0" and remote control DIP switches (see page 118)
bd	Control mode without remote control	Communication error, remote control Vitotrol heating circuit 2 (with mixer)	Check connections, cable, coding address "A0" and remote control DIP switches (see page 118)

Fault codes (cont.)

Fault code on the display	System characteristics	Cause	Measures
bE	Control mode	Vitotrol remote control incorrectly programmed	Check remote control DIP switch setting (see page 118)
bF	Control mode	Incorrect LON communication module	Replace the LON communication module
C4	Control mode	Communication error, Open Therm extension	Check Open Therm extension
C5	Control mode, max. pump speed	Communication fault, variable speed internal pump	Check the setting of coding address "30"
C6	Control mode, max. pump speed	Communication error, external variable speed heating circuit pump, heating circuit 2 (with mixer)	Check setting of coding address "E5".
C7	Control mode, max. pump speed	Communication error, external variable speed heating circuit pump, heating circuit 1 (without mixer)	Check setting of coding address "E5".
Cd	Control mode	Communication fault, Vitocom 100 (KM BUS)	Check connections, Vitocom 100 and coding address "95"
CE	Control mode	Communication fault, ext. extension	Check connections and coding address "2E"
CF	Control mode	Communication fault, LON communication module	Replace the LON communication module
dA	Control mode without room influence	Short circuit, room temperature sensor, heating circuit 1 (without mixer)	Check room temperature sensor, heating circuit 1



Fault codes (cont.)

Fault code on the display	System characteristics	Cause	Measures
db	Control mode without room influence	Short circuit, room temperature sensor, heating circuit 2 (with mixer)	Check room temperature sensor, heating circuit 2
dd	Control mode without room influence	Lead break, room temperature sensor, heating circuit 1 (without mixer)	Check room temperature sensor, heating circuit 1 and remote control DIP switch settings (see page 118)
dE	Control mode without room influence	Lead break, room temperature sensor, heating circuit 2 (with mixer)	Check room temperature sensor, heating circuit 2 and remote control DIP switch settings (see page 118)
E4	Burner blocked	Fault, supply voltage 24 V	Replace the control unit.
E5	Burner blocked	Fault – flame amplifier	Replace the control unit.
E8	Burner in a fault state	The ionisation current lies outside the permissible range	Check the ionisation electrode and cable. Press reset button R .
E9	Burner in a fault state	The ionisation current lies outside the permissible range during calibration	Check the ionisation electrode and cable. Check the flue gas system for tightness. Press reset button R .
EA	Burner in a fault state	The ionisation current lies outside the permissible range during calibration	Check the ionisation electrode and cable. Press reset button R .
Eb	Burner in a fault state	Heat draw-off repeatedly too low during calibration	Initiate a heat draw-off. Switch the boiler OFF and ON again. Press reset button R . Set coding address 12:1. This special function leads to heat being transferred to the heating circuit during calibration.

Fault codes (cont.)

Fault code on the display	System characteristics	Cause	Measures
EC	Burner in a fault state	The ionisation current lies outside the permissible range during calibration	Check the ionisation electrode and cable. Press reset button R .
Ed	Burner in a fault state	Internal fault	Replace the control unit.
F0	Burner blocked	Internal fault	Replace the control unit.
F1	Burner in a fault state	Flue gas temperature limiter has responded.	Check the heating system fill level. Vent the system. Press reset button R after the flue system has cooled down.
F2	Burner in a fault state	The temperature limiter has responded	Check the heating system fill level. Check the circulation pump. Vent the system. Check the temperature limiter and connecting cables. Press reset button R .
F3	Burner in a fault state	Flame signal is already present at burner start.	Check the ionisation electrode and connecting cable. Press reset button R .
F4	Burner in a fault state	No flame signal	Check the ionisation electrode and connecting cable, measure the ionisation current, check the gas pressure, check the gas train, ignition, ignition module, ignition electrodes and the condensate drain. Press reset button R .
F8	Burner in a fault state	The fuel valve closes too late	Check the gas train. Check both control paths. Press reset button R .

Fault codes (cont.)

Fault code on the display	System characteristics	Cause	Measures
F9	Burner in a fault state	Fan speed too low during the burner start	Check the fan, check the fan connecting cables and power supply; check the fan control. Press reset button R .
FA	Burner in a fault state	Fan not at standstill	Check the fan, fan connecting cables and fan control. Press reset button R .
FC	Burner in a fault state	Gas train faulty or faulty modulation valve control; or flue gas path blocked	Check the gas train. Check flue gas system. Press reset button R .
Fd	Burner in a fault state	Burner control unit fault	Check ignition electrodes and connecting cables. Check whether a strong interference (EMC) field exists near the equipment. Press reset button R . Replace control unit if the fault persists.
FE	Burner blocked or in a fault state	Boiler coding card or main PCB faulty	Press reset button R . Replace boiler coding card or control unit if the fault persists.
FF	Burner blocked or in a fault state	Internal fault or reset button R blocked	Start the equipment again. Replace the control unit if the equipment will not restart.

Repairs

Putting control unit in maintenance position

If required for commissioning and servicing, the control unit can be put in a different position.

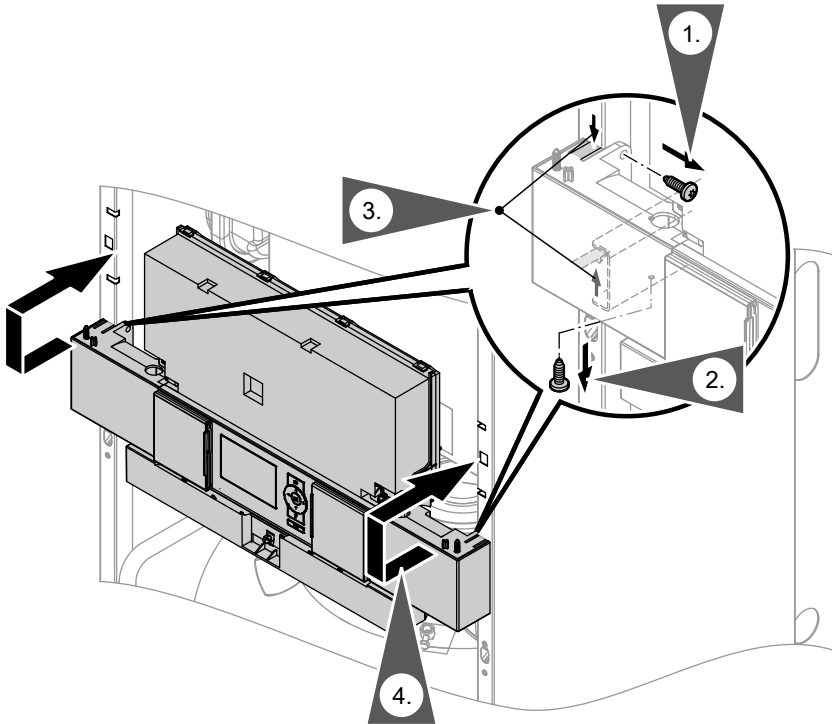

Repairs (cont.)

Draining the boiler on the heating water side

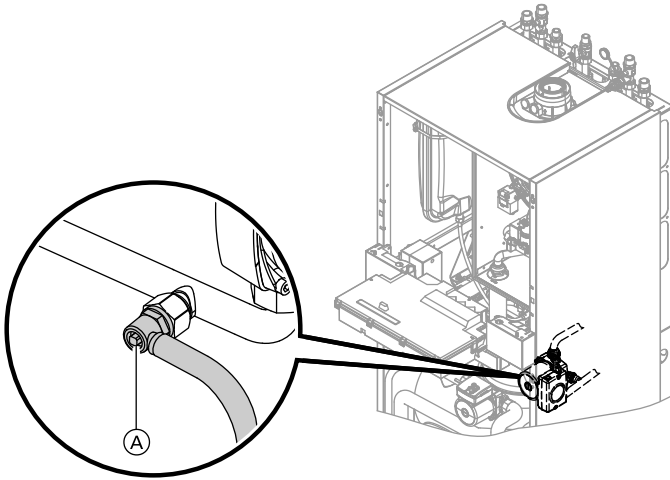

1. Close the shut-off valves on the heating water side.
2. Route hose at drain valve (A) into a suitable container or drain outlet.
3. Open drain valve (A) and drain the boiler as much as required.

Repairs (cont.)

Checking the outside temperature sensor

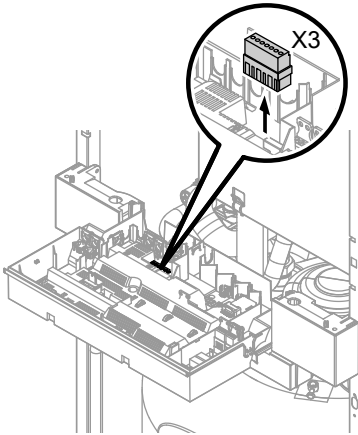

1. Pull plug "X3" from the control unit.
2. Test the resistance of the outside temperature sensor across terminals "X3.1" and "X3.2" on the disconnected plug and compare it with the curve.
3. Where actual values strongly deviate from the curve values, disconnect the wires at the sensor and repeat test on the sensor itself.
4. Subject to result, replace the lead or the outside temperature sensor.

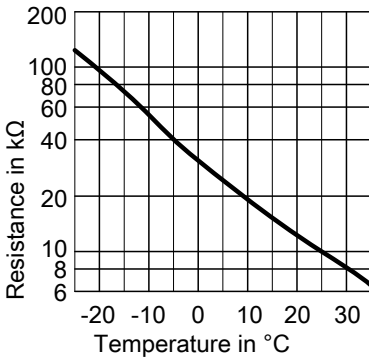

Repairs (cont.)

Checking the boiler temperature sensor, cylinder temperature sensor or flow temperature sensor for the low loss header

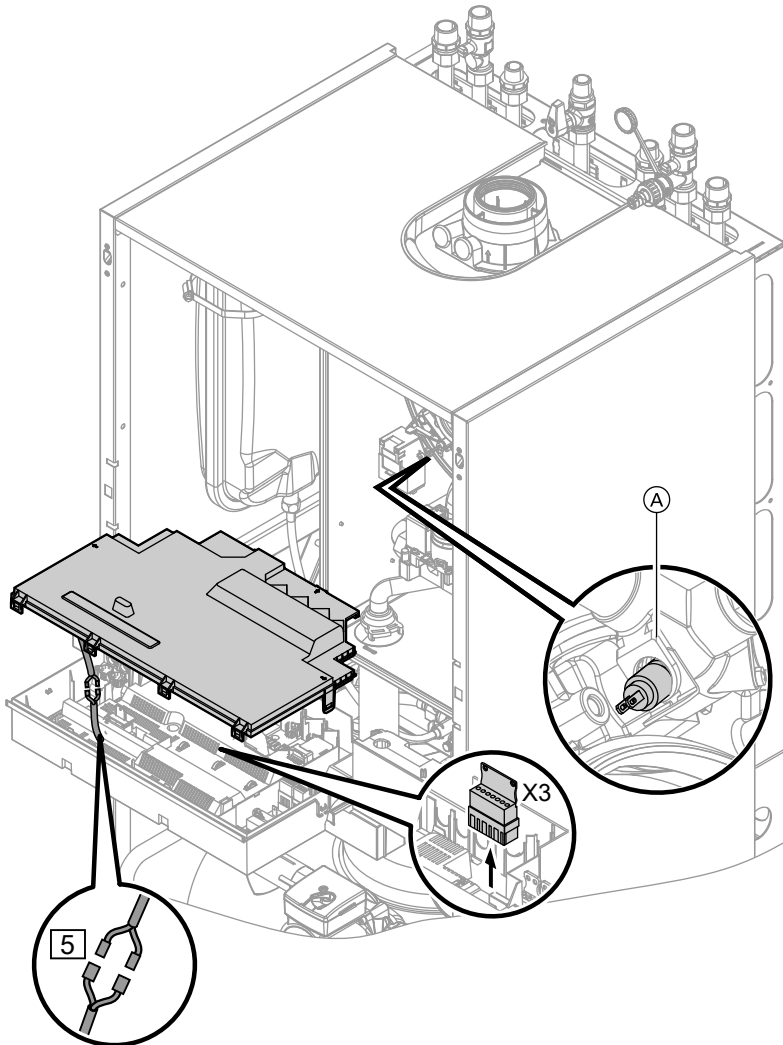

Repairs (cont.)

1. ■ **Boiler water temperature sensor**
Pull the leads from boiler water temperature sensor (A) and check the resistance.
- **Cylinder temperature sensor**
Pull plug [5] from the cable harness at the control unit and check the resistance.
- **Flow temperature sensor**
Pull plug "X3" from the control unit and check the resistance across terminals "X3.4" and "X3.5".
2. Check the sensor resistance and compare the actual values with the curve.
3. Replace the sensor in case of severe deviation.

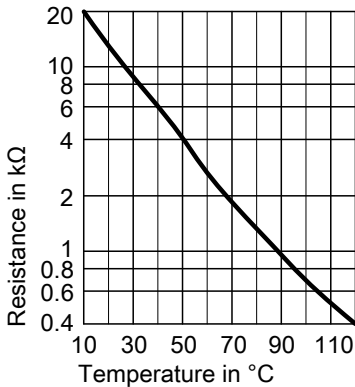

Danger

The boiler water temperature sensor is immersed in the heating water (risk of scalding).
Drain the boiler on the heating water side before replacing the sensor.

Checking collector temperature sensor or cylinder temperature sensor on the solar control module

The solar control module is attached to the l.h. side of the air box.

Repairs (cont.)

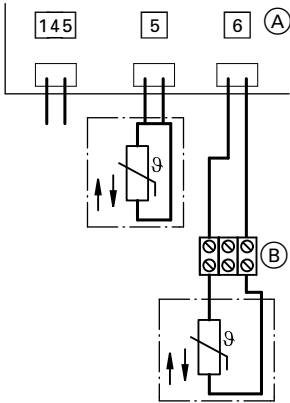

1. ■ **Cylinder temperature sensor**
Remove plug **5** from solar control module **(A)** and measure the resistance.
- **Collector temperature sensor**
Remove plug **6** from solar control module **(A)** and or disconnect lead from terminal box **(B)** and measure the resistance.

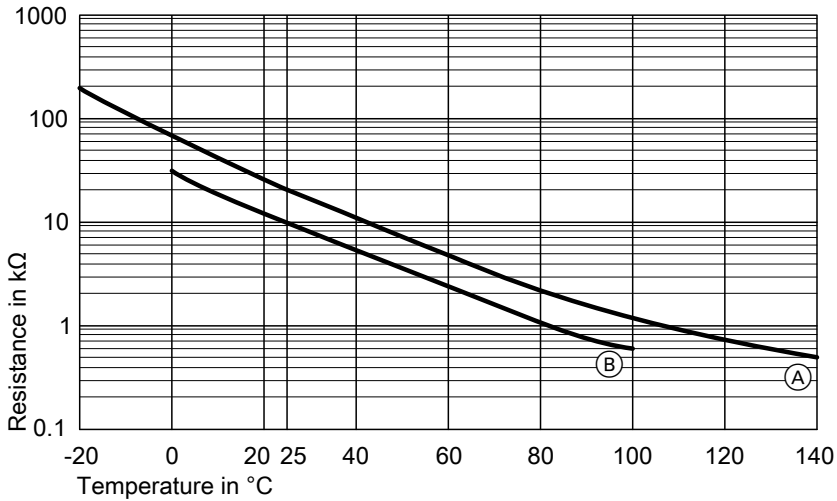

- (A) Collector temperature sensor
- (B) Cylinder temperature sensor

2. Compare the sensor resistance with the curve.
3. Replace the sensor in case of severe deviation.

Repairs (cont.)

Checking the outlet temperature sensor

1. Pull the leads from outlet temperature sensor (A).

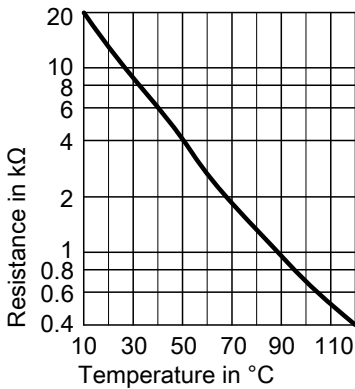
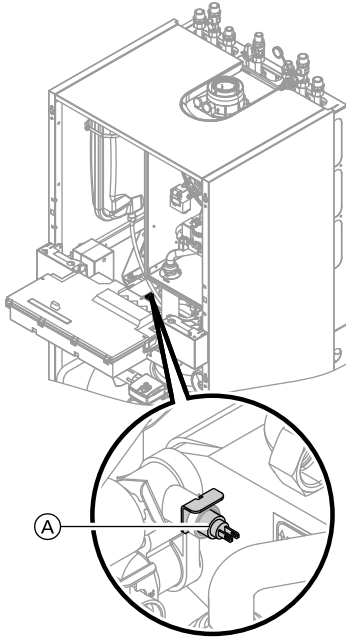

2. Check the sensor resistance and compare it with the curve.
3. Replace the sensor in case of severe deviation.



Danger

The outlet temperature sensor is immersed in the DHW (risk of scalding). Drain the DHW side of the boiler before replacing the sensor.

Repairs (cont.)

Check the flue gas temperature sensor

The flue gas temperature sensor locks out the boiler when the permissible flue gas temperature is exceeded. Reset the interlock after the flue system has cooled down by pressing reset button **R**.

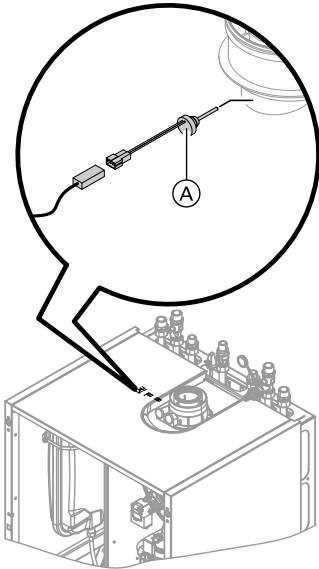

1. Pull the leads from flue gas temperature sensor (A).

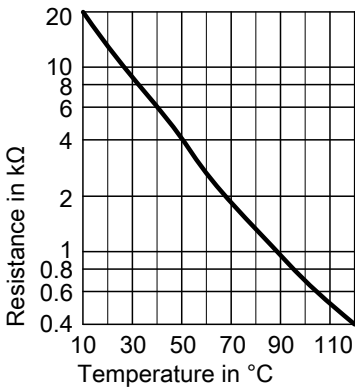

2. Check the sensor resistance and compare it with the curve.
3. Replace the sensor in case of severe deviation.

Repairs (cont.)

Checking the plate heat exchanger

Note

Drain the boiler on its heating water and DHW side.

During removal, small amounts of water may trickle out and escape from the removed plate heat exchanger.

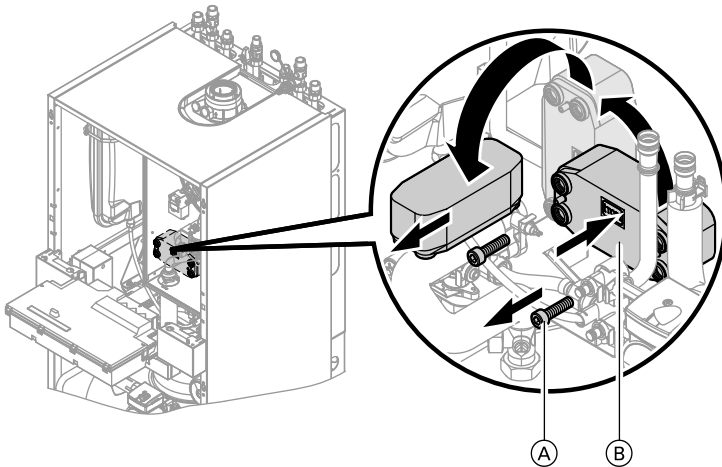

1. Shut off and drain the boiler on its heating water and DHW side.
2. Release the side closures and pivot the control unit forward.
3. Remove the siphon (see page 27).
4. Undo two screws (A) and pull out plate heat exchanger (B) with insulation to the front.
5. Check the connections on the heating water and DHW side for contamination and scaling; if required, replace the plate heat exchanger.
6. Lubricate the new gaskets/seals. Install in reverse order with new gaskets.

Checking the temperature limiter

If the burner control unit cannot be reset after a fault shutdown, although the boiler water temperature is below approx. 75 °C, check the following:

Repairs (cont.)

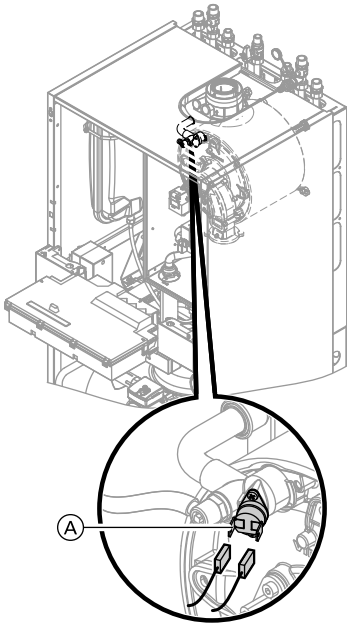

1. Pull the leads from temperature limiter **A**.
2. Check the continuity of the temperature limiter with a multimeter.
3. Remove the faulty temperature limiter.
4. Coat the replacement temperature limiter with heat conducting paste and install it.
5. After commissioning, press reset button **R** on the control unit.

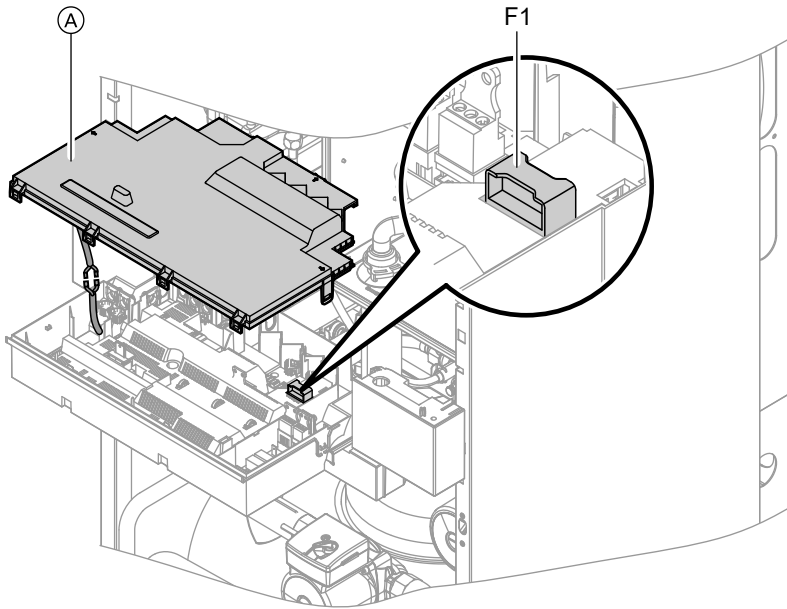
Repairs (cont.)**Checking the fuse**

1. Switch OFF the power.
2. Release the side closures and pivot the control unit down.
3. Remove cover (A).
4. Check fuse F1 (see connection and wiring diagram).

Repairs (cont.)

Checking the solar control module fuse

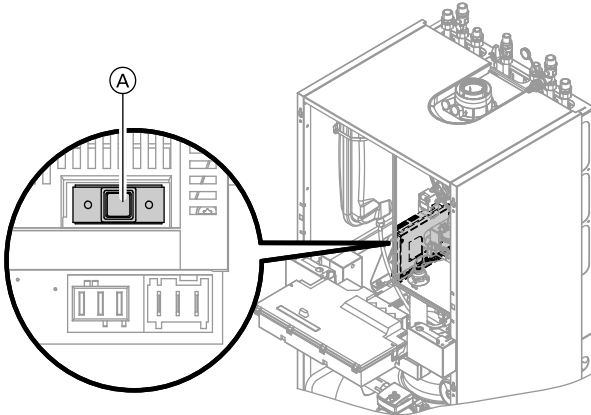

1. Switch OFF the power.
2. Check fuse (A) in the solar control module (see connection and wiring diagram).

Extension kit for heating circuit with mixer

Note

The DIP switch on the PCB of the extension set must be set to "2".

Checking the rotational direction of the mixer motor

After being switched on, the boiler implements a self-test. During this, the mixer is opened and closed again.

Note the rotational direction of the mixer motor during its self-test.

Then set the mixer manually to "Open" again.

Note

The flow temperature sensor must now capture a higher temperature. If the temperature drops, either the motor is turning in the wrong direction or the mixer set is incorrectly fitted.



Mixer installation instructions

Repairs (cont.)

In the delivered condition, the mixer motor is set up for the following mixer arrangement (heating return from the left).

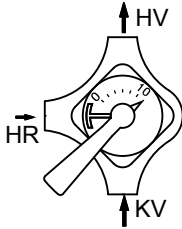

For the following mixer arrangement (heating return from the right), change the rotational direction.

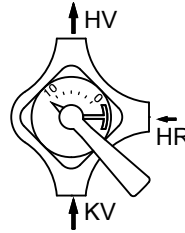

Changing the rotational direction of the mixer motor (if required)



Danger

An electric shock can be life-threatening.

Before opening the boiler, disconnect from the mains voltage, for example at the fuse or the main isolator.

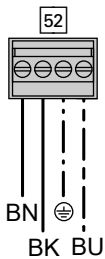

1. Remove the upper casing cover of the extension kit.
2. Change the rotational direction by switching wires BN and BK at plug 52.

Checking the Vitotronic 200-H (accessories)

The Vitotronic 200-H is connected to the control unit via the LON cable. To test the connection, carry out a subscriber check at the boiler control unit (see page 57).

(cont.)

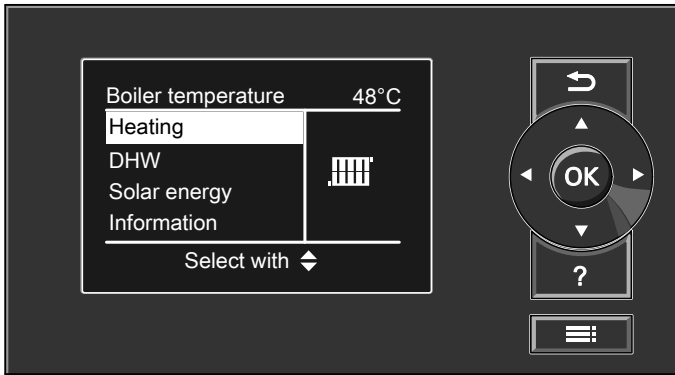

Heating operation

The control unit determines a set boiler water temperature subject to outside temperature or room temperature (if a room temperature-dependent remote control is connected) and to the slope/level of the heating curve.

The determined set boiler water temperature is transferred to the burner control unit. From the set and actual boiler water temperatures, the burner control unit calculates the modulation level and regulates the burner accordingly.

The electronic temperature limiter inside the burner control unit limits the boiler water temperature to 82 °C.

Heating the DHW primary cylinder from cold

The heating circuit pump is switched ON and the three-way diverter valve will be changed over, if the cylinder temperature sensor captures a temperature lower than the defaulted set temperature.

- The cylinder primary pump is switched ON if the boiler water temperature \geq set DHW temperature.
- The burner is switched ON if the boiler water temperature \leq set DHW temperature, and the cylinder primary pump is switched ON when the required boiler water temperature is reached.

(cont.)

The primary cylinder is heated up to the set DHW temperature. Heating stops when the set temperatures have been reached at the cylinder temperature sensor and at the outlet temperature sensor.

After heating, the cylinder primary pump and the three-way diverter valve remain ON for a further 30 s.

Boosting when DHW is drawn off

When DHW is drawn off, cold water enters at the bottom of the primary cylinder.

The heating circuit pump is switched ON and the three-way diverter valve is changed over, if the cylinder temperature sensor recognises a temperature lower than the set temperature.

- The cylinder primary pump is switched ON if the boiler water temperature \geq set DHW temperature.
- The burner is switched ON if the boiler water temperature \leq set DHW temperature, and the cylinder primary pump is switched ON when the required boiler water temperature is reached.

The DHW is controlled to the specified temperature via the cylinder temperature sensor.

The primary cylinder continues to be heated up after the draw off process has terminated, until the set DHW temperature has been reached at the cylinder temperature sensor.

The cylinder primary pump and the three-way diverter valve remain ON for a further 30 s.

DHW heating via solar collectors

If a temperature differential is measured between the collector temperature sensor and the cylinder temperature of the solar control module, which is greater than the start temperature differential set in the control unit, the solar circuit pump is started and the DHW cylinder is heated.

The pump is stopped when the value falls below the shutdown temperature differential between the collector temperature sensor and the cylinder temperature sensor of the solar control unit.

The solar circuit pump is stopped when the set maximum temperature or the temperature set at the high limit safety cut-out is reached.

Internal extensions

Internal extension H1

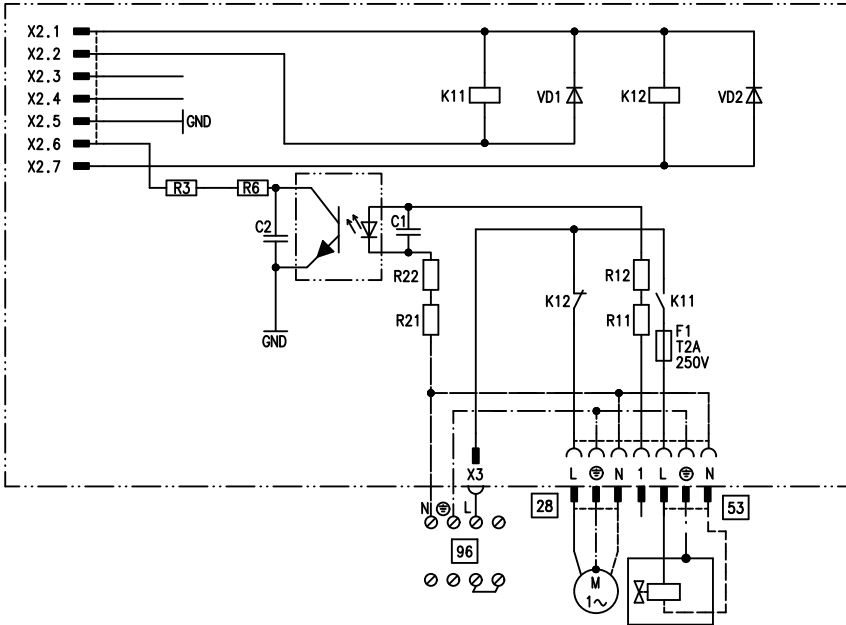

The internal extension H1 is integrated into the control unit casing. The cylinder primary pump is connected to relay output [28].

An external safety valve can be connected to [53].

Internal extensions (cont.)

Internal extension H2 (accessories)

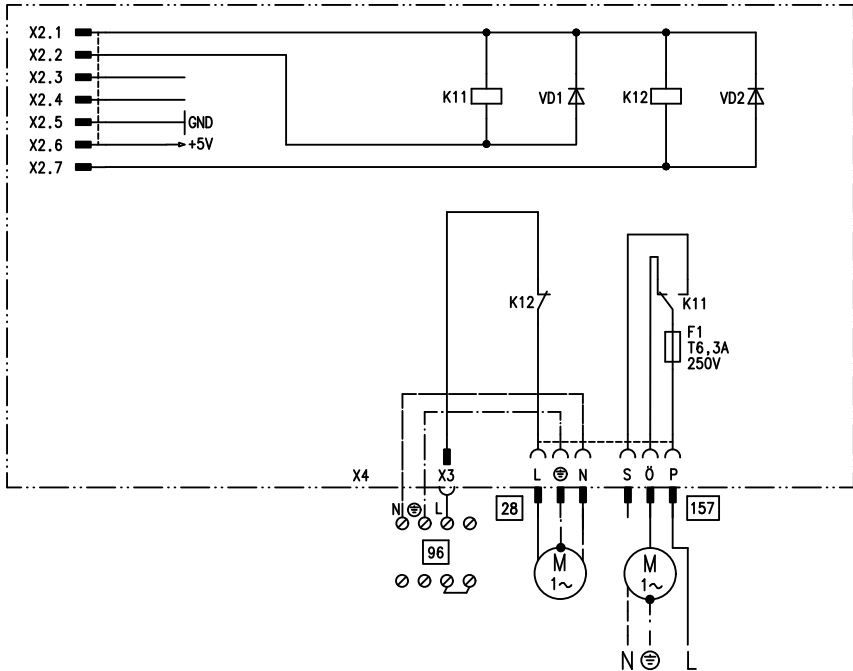

The internal extension H2 is integrated into the control unit casing instead of the internal extension H1. The cylinder primary pump is connected to relay output **28**.

An external extractor interlock can be connected to **157**.

External extensions (accessories)

External extension H1

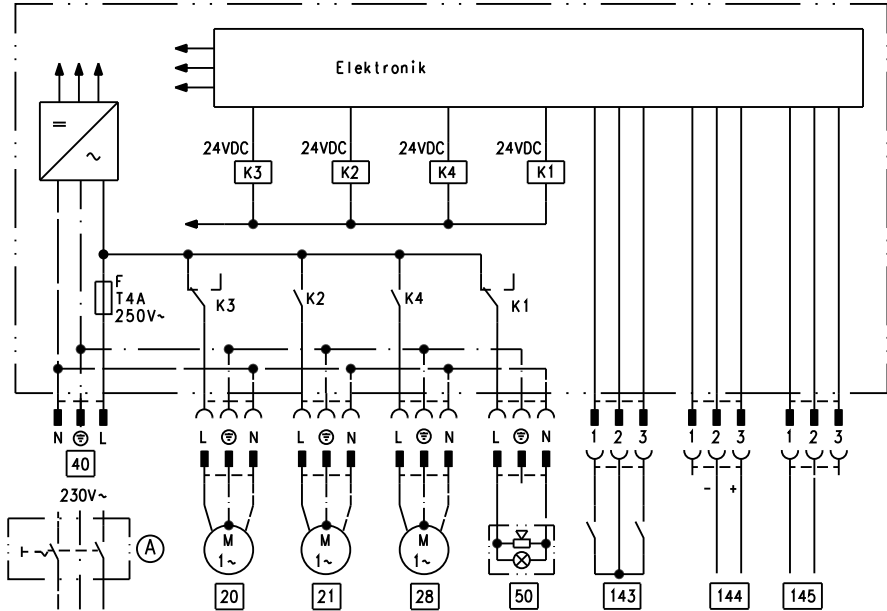

The external extension is connected to the boiler control unit via the KM BUS. The following functions can be controlled or processed simultaneously via the extension:

- Ⓐ ON/OFF switch (on site)
- 20 Heating circuit pump for the heating circuit without mixer
- 21 Circulation pump for cylinder heating
- 28 DHW circulation pump (only for weather-compensated operation)
- 40 Power supply
- 50 Central fault message

- 143 ■ External blocking (terminals 2 - 3)
- External demand (terminals 1 - 2)
- External heating program changeover (terminals 1 - 2) (only for weather-compensated operation)
The allocation of function "External heating program changeover" is set via coding address "91"
- 144 External set value 0 to 10 V
- 145 KM BUS

External extensions (accessories) (cont.)

External extension H2

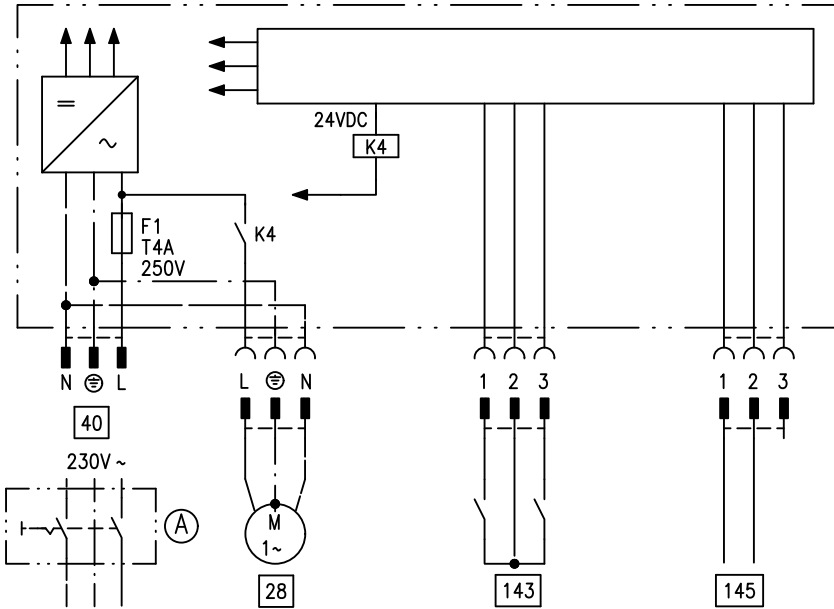

The external extension is connected to the boiler control unit via the KM BUS. The following functions can be controlled or processed simultaneously via the extension:

- Ⓐ ON/OFF switch (on site)
- 28 DHW circulation pump (only for weather-compensated operation)
- 40 Power supply

- 143 ■ External blocking (terminals 2 - 3)
- External demand (terminals 1 - 2)
- External heating program changeover (terminals 1 - 2) (only for weather-compensated operation)
The allocation of the function "External heating program changeover" is set via coding address "91".
- 145 KM BUS

Control functions

External heating program changeover

The "External heating program changeover" function is connected via external extension input "143". You can select which heating circuits the heating program changeover affects in coding address "91":

Heating program changeover	Coding
No changeover	91:0
Heating circuit without mixer A1	91:1
Heating circuit with mixer M2	91:2
Heating circuit without mixer and heating circuit with mixer	91:3

You can select in which direction the heating program changes over in coding address "D5":

Heating program changeover	Coding
Changeover towards "Permanently reduced" or "Permanent standby" mode (subject to the selected set value)	d5:0
Changeover towards "Constant heating mode"	d5:1

The duration of the heating program changeover can be adjusted in coding address "F2":

Heating program changeover	Coding
No heating program changeover	F2:0
Duration of the heating program changeover 1 to 12 hours	F2:1 to F2:12

The heating program changeover stays enabled for as long as the contact remains closed, but at least as long as the duration selected in coding address "F2".

Control functions (cont.)

External blocking

The "External blocking" function is connected via external extension input "143".

In coding address "32" you can select the influence the "Ext. blocking" signal should have on the connected circulation pumps.

External demand

The "External demand" function is connected via external extension input "143".

In coding address "34" you can select the influence the "Ext. demand" signal should have on the connected circulation pumps.

The minimum set boiler water temperature in case of external demand is selected in coding address "9b".

Venting program

During the venting program, the circulation pump will be alternately switched ON and OFF for 30 s respectively over a period of 20 min.

For a certain period, the diverter valve is alternately set towards heating and DHW heating. The burner is switched OFF during the venting program.

The venting program is activated via code "2F:1". The program is automatically disabled after 20 min, and coding address "2F" is set to "0".

Fill program

In the delivered condition, the diverter valve is set to its central position, enabling the system to be filled completely. After switching ON the control unit, the diverter valve no longer goes into its central position.

Afterwards, the diverter valve can be moved via code "2F:2" into the central position. In this position, the control unit can be switched OFF, and the system can be filled completely.

Filling with the control unit switched ON

If the system is to be filled with the control unit switched ON, the diverter valve will be moved to its central position via code "2F:2" and the pump will be started.

The burner shuts down if this function is enabled via coding address "2F". The program is automatically disabled after 20 min, and coding address "2F" is set to "0".

Control functions (cont.)

Screed drying function

The screed function enables screeds to be dried. For this, always observe the details specified by the screed manufacturer.

When the screed drying function is activated, the heating circuit pump of the mixer circuit is switched ON and the flow temperature will be held at the selected profile. After completion (30 days), the mixer circuit will again be regulated automatically via the set parameters.

Observe EN 1264. The report to be provided by the heating contractor must contain the following heat-up details:

- Heat-up data with respective flow temperatures
- Max. flow temperature achieved
- Operating condition and outside temperature during handover

The various temperature profiles are adjustable via coding address "F1".

The function continues after power failure or after the control unit has been switched OFF. "Heating and DHW" will be started after the screed drying function has been terminated or if code "F1:0" is manually adjusted.

Temperature profile 1: (EN 1264-4) code "F1:1"

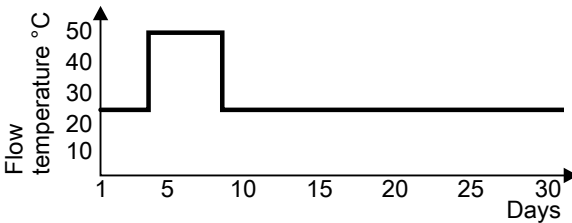

Temperature profile 2: (ZV parquet and flooring technology) code "F1:2"

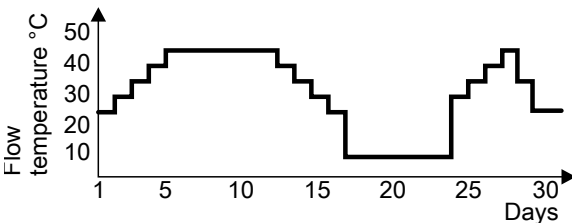

Control functions (cont.)

Temperature profile 3: Code "F1:3"

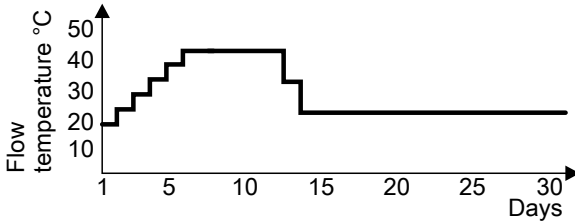

Temperature profile 4: Code "F1:4"

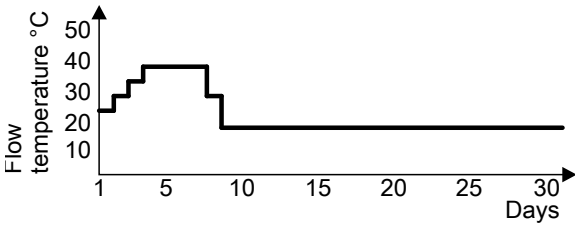

Temperature profile 5: Code "F1:5"

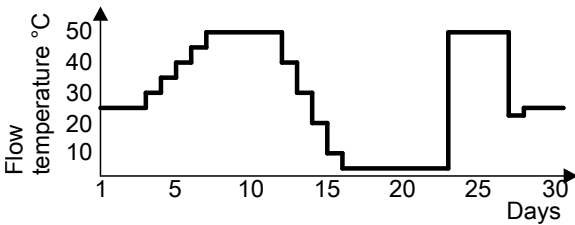

Control functions (cont.)

Temperature profile 6: Code "F1:6"

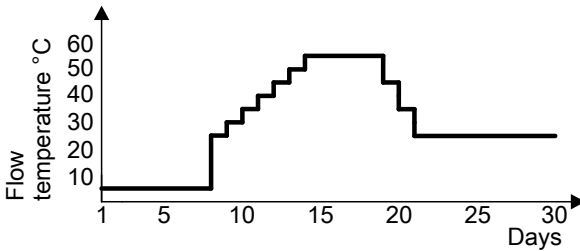

Temperature profile 7: Code "F1:15"

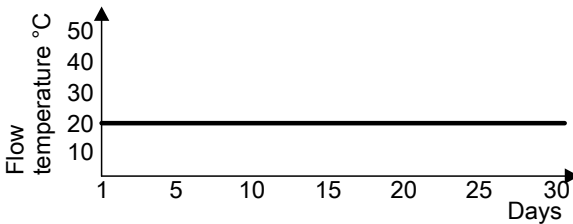

Raising the reduced room temperature

During operation with reduced room temperature, the reduced set room temperature can be automatically raised subject to the outside temperature. The temperature is raised in accordance with the selected heating curve, but no higher than the set standard room temperature.

The outside temperature limits for the start and end of the temperature raising can be adjusted via coding addresses "F8" and "F9".

Control functions (cont.)

Example using the settings in the delivered condition

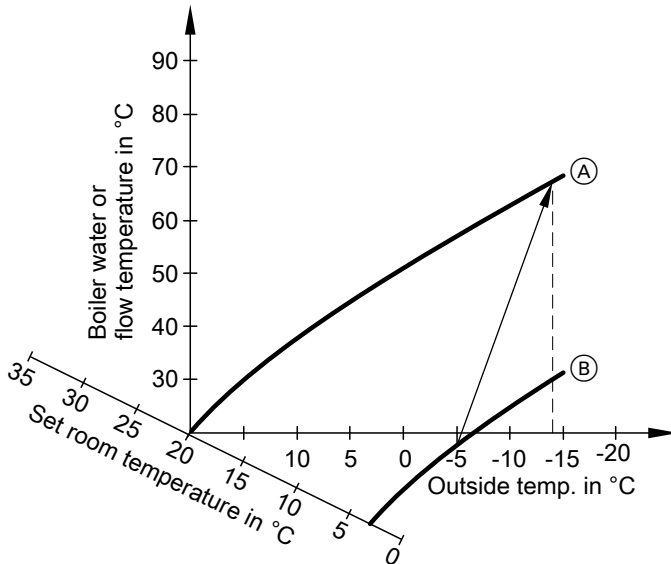

Ⓐ Heating curve for operation with standard room temperature

Ⓑ Heating curve for operation with reduced room temperature

Reducing the heat-up time

During the transition from operation with reduced room temperature to operation with standard room temperature, the boiler water or flow temperature will be raised in accordance with the selected heating curve. The boiler water or flow temperature can be automatically increased.

The value and duration of the additional increase of the set boiler water or flow temperature can be adjusted in coding addresses "FA" and "Fb".

Control functions (cont.)

Example using the settings in the delivered condition

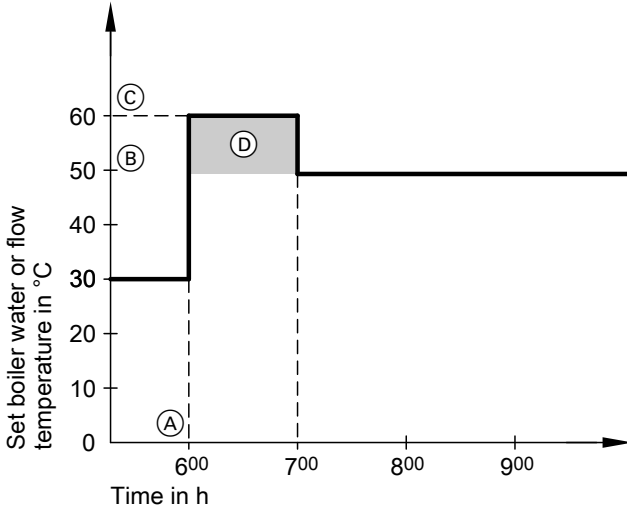



- (A) Start of operation with standard room temperature
- (B) Set boiler water or flow temperature in accordance with the selected heating curve
- (C) Set boiler water or flow temperature in accordance with coding address "FA":
 $50\text{ °C} + 20\% = 60\text{ °C}$
- (D) Duration of operation with raised set boiler water or flow temperature in accordance with coding address "Fb":
60 min

Remote control DIP switches

The DIP switches are located on the PCB in the top part of the casing.

Remote control DIP switches (cont.)

Remote control	DIP switch setting
The remote control affects the heating circuit without mixer A1	<p>ON</p>  <p>1 2 3 4</p>
The remote control affects the heating circuit with mixer M2	<p>ON</p>  <p>1 2 3 4</p>
When connecting a separate room temperature sensor, set DIP switch "3" to "ON".	<p>ON</p>  <p>1 2 3 4</p>

Electronic combustion controller

The electronic combustion controller utilises the physical correlation between the level of the ionisation current and the air factor λ . For all gas qualities, the maximum ionisation current results with air factor 1.

The ionisation signal is evaluated by the combustion controller, and the air factor is adjusted to between $\lambda=1.24$ and 1.44. This range provides for an optimum combustion quality. Thereafter, the electronic gas valve regulates the required gas volume subject to the prevailing gas quality.

To check the combustion quality, the CO_2 content or the O_2 content of the flue gas is measured. The actual values enable the prevailing air factor to be determined. The relationship between the CO_2 or O_2 content and air factor λ is illustrated in the following table.

Electronic combustion controller (cont.)**Air factor λ – CO₂/O₂ content**

Air factor λ	O₂ content (%)	CO₂ content (%) for natural gas E	CO₂ content (%) for natural gas LL	CO₂ content (%) for LPG P LL
1.24	4.4	9.2	9.1	10.9
1.27	4.9	9.0	8.9	10.6
1.30	5.3	8.7	8.6	10.3
1.34	5.7	8.5	8.4	10.0
1.37	6.1	8.3	8.2	9.8
1.40	6.5	8.1	8.0	9.6
1.44	6.9	7.8	7.7	9.3

To achieve an optimum combustion control, the system regularly carries out an automatic self-calibration; also after a power failure (shutdown). For this, the combustion is briefly regulated to max. ionisation current (equals air factor $\lambda=1$). The automatic calibration is carried out shortly after the burner start and lasts approx. 5 s. During calibration, higher than normal CO emissions may occur briefly.

Internal connection diagram

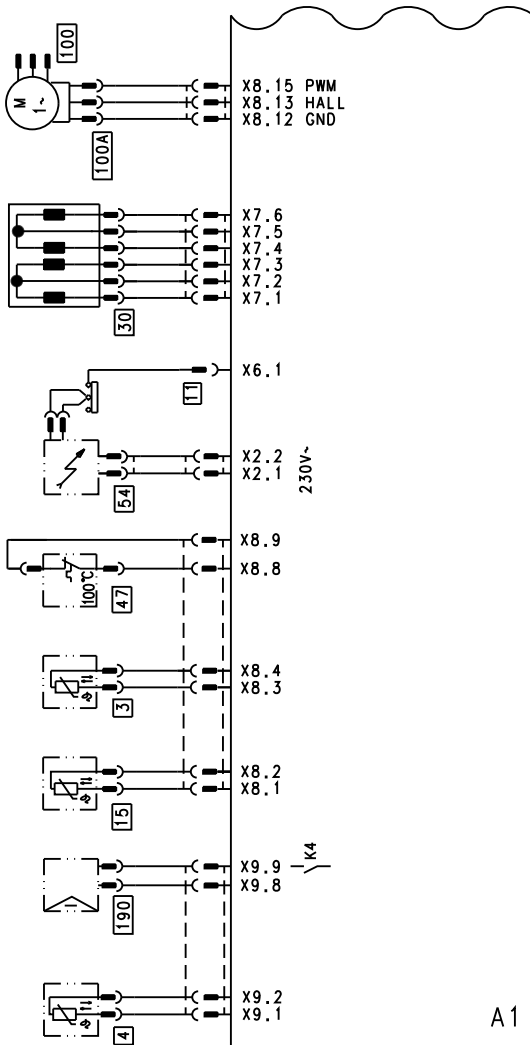

- | | | | |
|------|---------------------------------|------|----------------------------------|
| A1 | Main PCB | 30 | Stepper motor for diverter valve |
| X... | Electrical interfaces | 47 | Thermal circuit breaker |
| 3 | Boiler water temperature sensor | 54 | Ignition unit |
| 4 | Outlet temperature sensor | 100 | Fan motor |
| 11 | Ionisation electrode | 100A | Fan motor control |
| 15 | Flue gas temperature sensor | 190 | Modulation coil |

External connection diagram

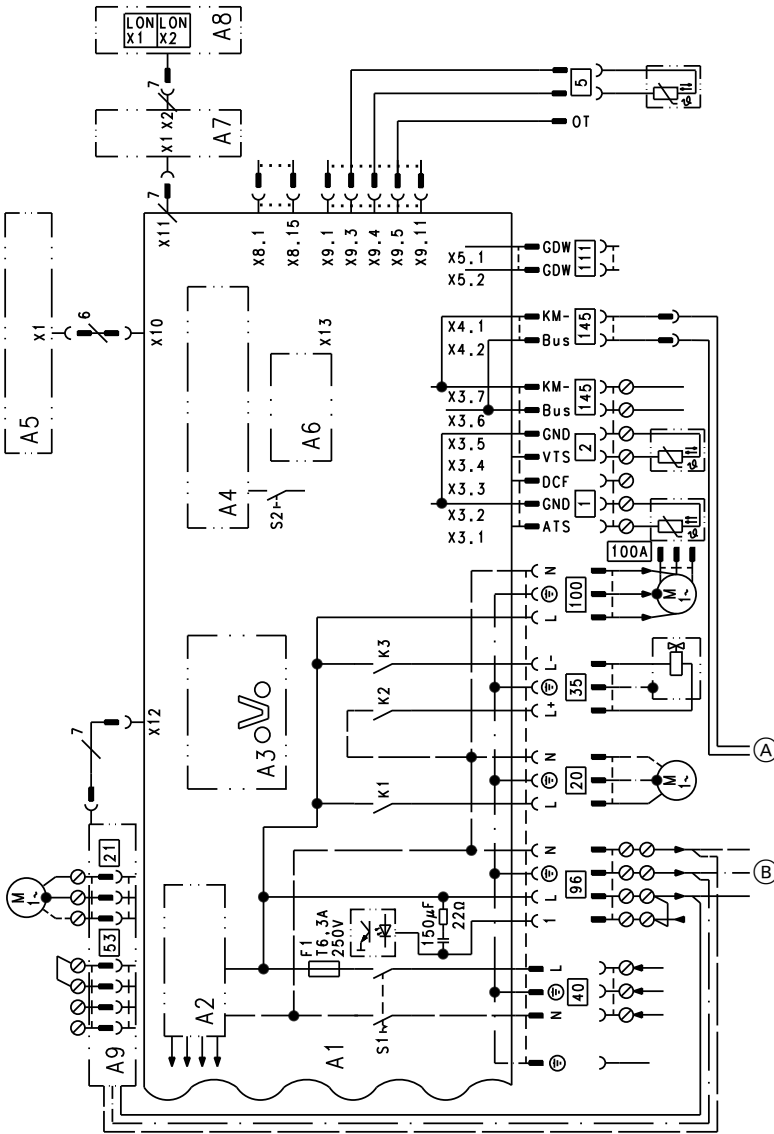

- | | | | |
|----|-------------------|----|---------------------|
| A1 | Main PCB | A4 | Burner control unit |
| A2 | Power supply unit | A5 | Programming unit |
| A3 | Optolink | A6 | Coding card |

External connection diagram (cont.)

A7	Connection adaptor	5	Cylinder temperature sensor (plug on the cable harness)
A8	LON communication module	20	Internal circulation pump
A9	Internal extension H1	35	Gas solenoid valve
S1	ON/OFF switch	40	Power supply
S2	Reset button	96	Power supply accessories and Vitolrol 100
X...	Electrical interfaces	100	Fan motor
Ⓐ	KM BUS to the solar control module	100A	Fan motor control
Ⓑ	Solar control module power supply	111	Gas pressure limiter
1	Outside temperature sensor	145	KM BUS
2	Flow temperature sensor, low loss header		

Connection diagram solar control module

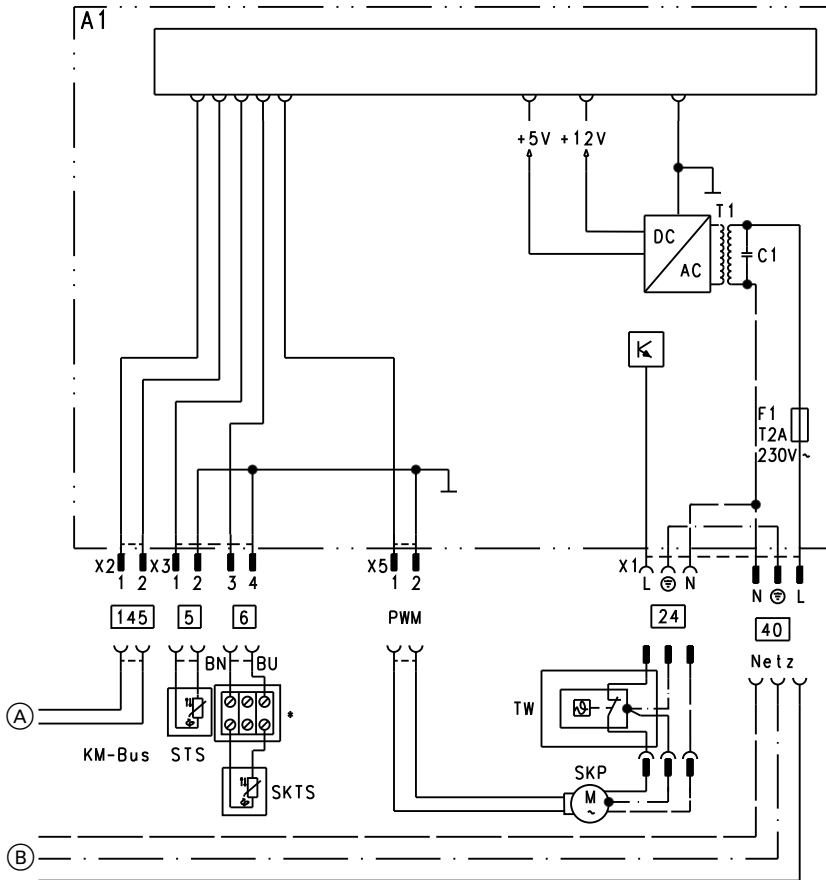

- | | | | |
|------|------------------------------------|-----|------------------------------|
| A1 | Main PCB | 6 | Collector temperature sensor |
| X... | Electrical interfaces | 24 | Solar circuit pump |
| (A) | KM BUS from the control unit | 40 | Power supply |
| (B) | Power supply from the control unit | 145 | KM BUS |
| 5 | Cylinder temperature sensor | | |

Parts lists

Spare parts information

Quote the part and serial no. (see type plate) and the item number of the required part (as per this parts list). Obtain standard parts from your local supplier.

- | | | | |
|-----|--|-----|---|
| 001 | Diaphragm expansion vessel | 035 | Connection pipework, heating water return |
| 002 | Connection line; diaphragm expansion vessel | 036 | Connection pipework, cold water |
| 003 | Cap panel with gasket | 037 | DHW connection pipe |
| 004 | Profiled seal | 038 | Heating water flow connection pipe |
| 005 | Boiler flue connection | 039 | Cold water connection |
| 006 | Plug | 040 | Heating water return connection pipe |
| 007 | Ventilation air gasket | 041 | Connecting pipe, central draw-off |
| 008 | Flue gas gasket | 042 | Solar return connecting pipe |
| 010 | Heat exchanger | 043 | Solar circuit pump connecting pipe |
| 011 | Moulded hose, return | 044 | Solar flow connecting pipe |
| 012 | Condensate hose | 045 | Connector for solar filling equipment |
| 013 | Siphon | 046 | Filling facility for solar heat transfer medium |
| 015 | Hose 19 x 800 mm, corrugated | 047 | Solar connection elbow |
| 016 | Condensate hose (400 mm long) | 048 | Sensor well |
| 017 | Hose 19 x 1100 mm, corrugated | 050 | Flow unit |
| 019 | Condensate manifold | 051 | Return unit |
| 020 | Spacer | 052 | Overflow valve |
| 021 | Safety valve | 053 | Plug \varnothing 8/10 mm |
| 022 | Right-angle shut-off valve, central draw-off | 054 | Plate heat exchanger |
| 023 | Hose ferrule | 055 | Profiled gasket |
| 024 | Right-angle shut-off valve, DHW cylinder heating | 056 | Valve insert |
| 025 | Connection line, DHW heating | 057 | Overflow pipe |
| 026 | Bezel | 058 | Plate heat exchanger insulation shell |
| 027 | Non-return valve | 059 | Plate heat exchanger insulation board |
| 028 | Air vent valve G 3/8" | 062 | Burner gauze assembly |
| 029 | Pressure gauge | 063 | Burner gauze assembly gasket |
| 030 | Right-angle shut-off valve, cylinder cold water | 066 | Gasket burner flange |
| 031 | Gas pipe | 067 | Fan |
| 032 | Flow pipe | 068 | Gas train |
| 033 | Connection pipe, cold water, cylinder | 069 | Burner door |
| 034 | Heating water flow connection pipe | 070 | Ignition unit |
| | | 071 | Ionisation electrode gasket |
| | | 072 | Ignition electrode gasket |
| | | 074 | Gas nozzle |
| | | 075 | Venturi extension |
| | | 080 | Gasket set A 16 x 24 x 2.0 |
| | | 081 | Gasket set A 17 x 24 x 2.0 |

Parts lists (cont.)

- | | | | |
|-----|---|-----|---|
| 310 | Cable harness X8/X9/Ionisation | 320 | Plug set, LV |
| 311 | Cable harness 100/35/54 (auxiliary earth) | 321 | Plug set, 230 V |
| 312 | Cable harness stepper motor | 401 | Operating instructions for weather-compensated mode |
| 313 | Mating plug set | 402 | Installation and service instructions |
| 314 | Cable fixing | Ⓐ | Type plate |
| 317 | Collector temperature sensor | | |
| 319 | Adaptor lead for collector temperature sensor | | |

Parts lists (cont.)

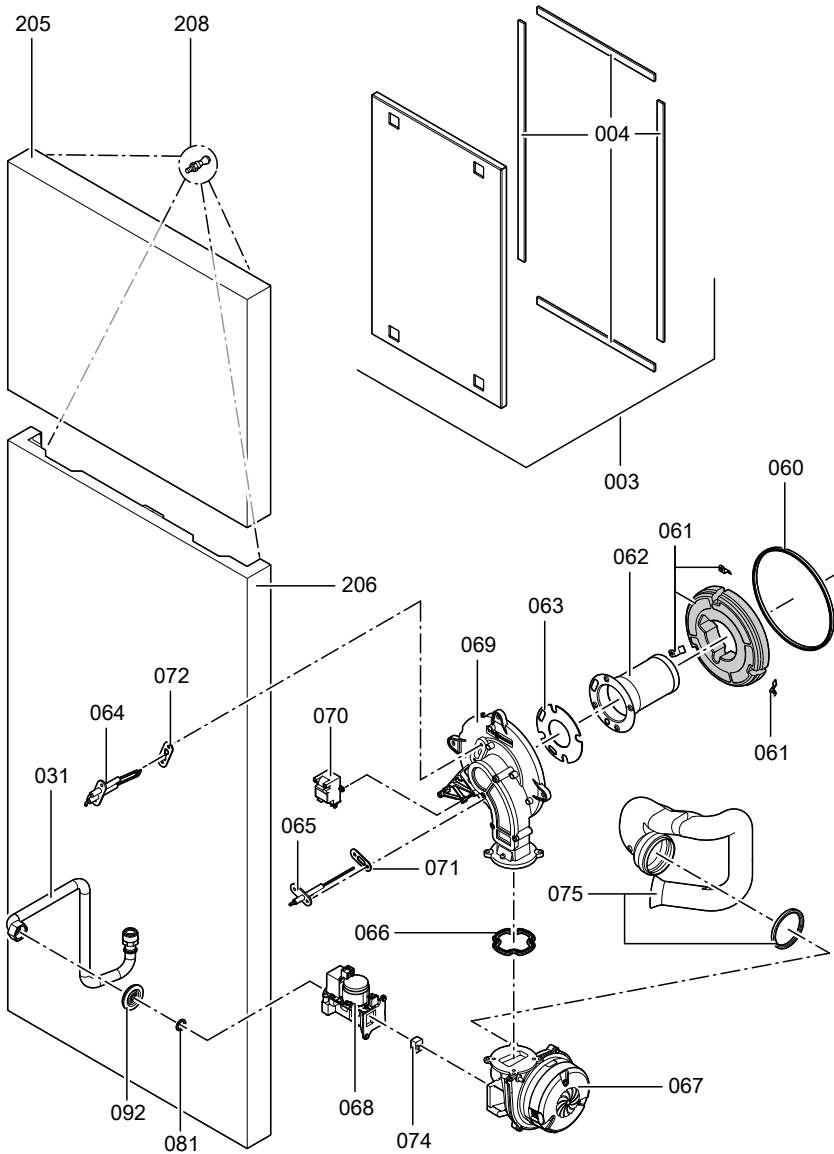

Parts lists (cont.)

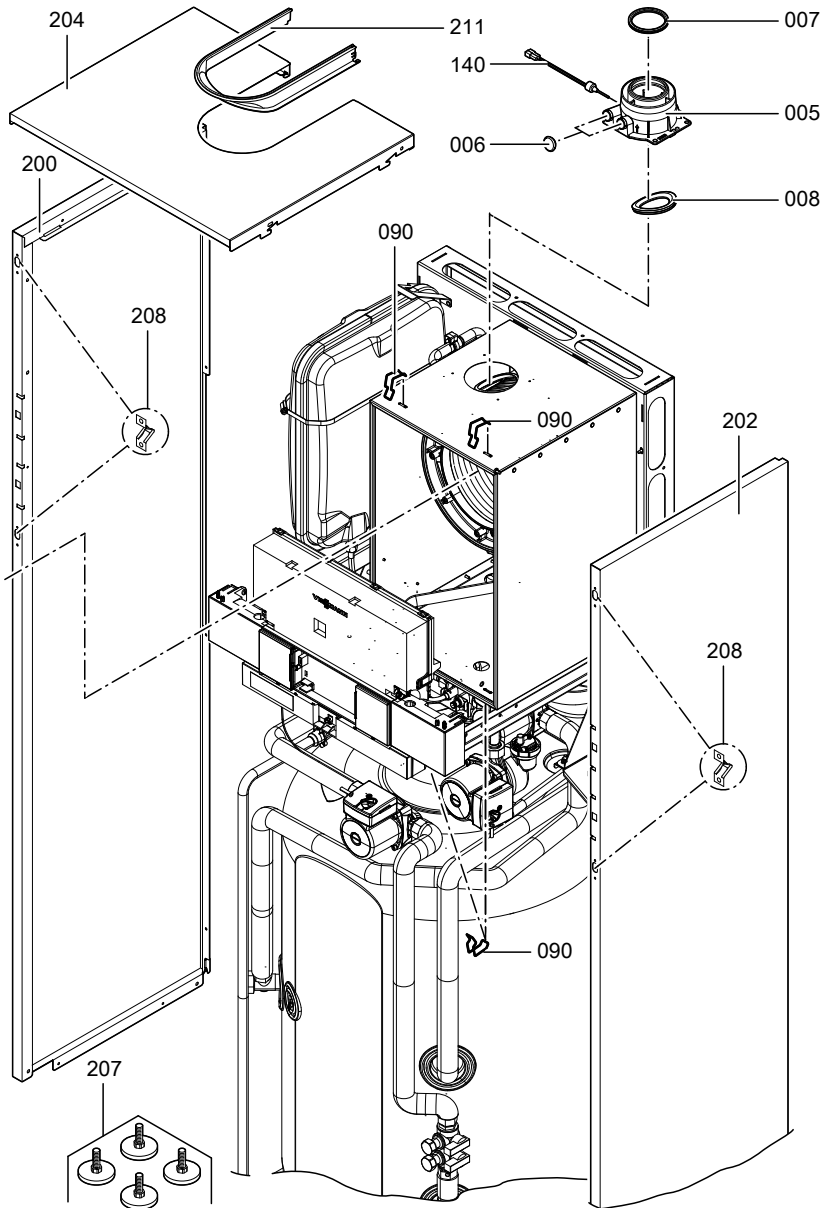

Parts lists (cont.)

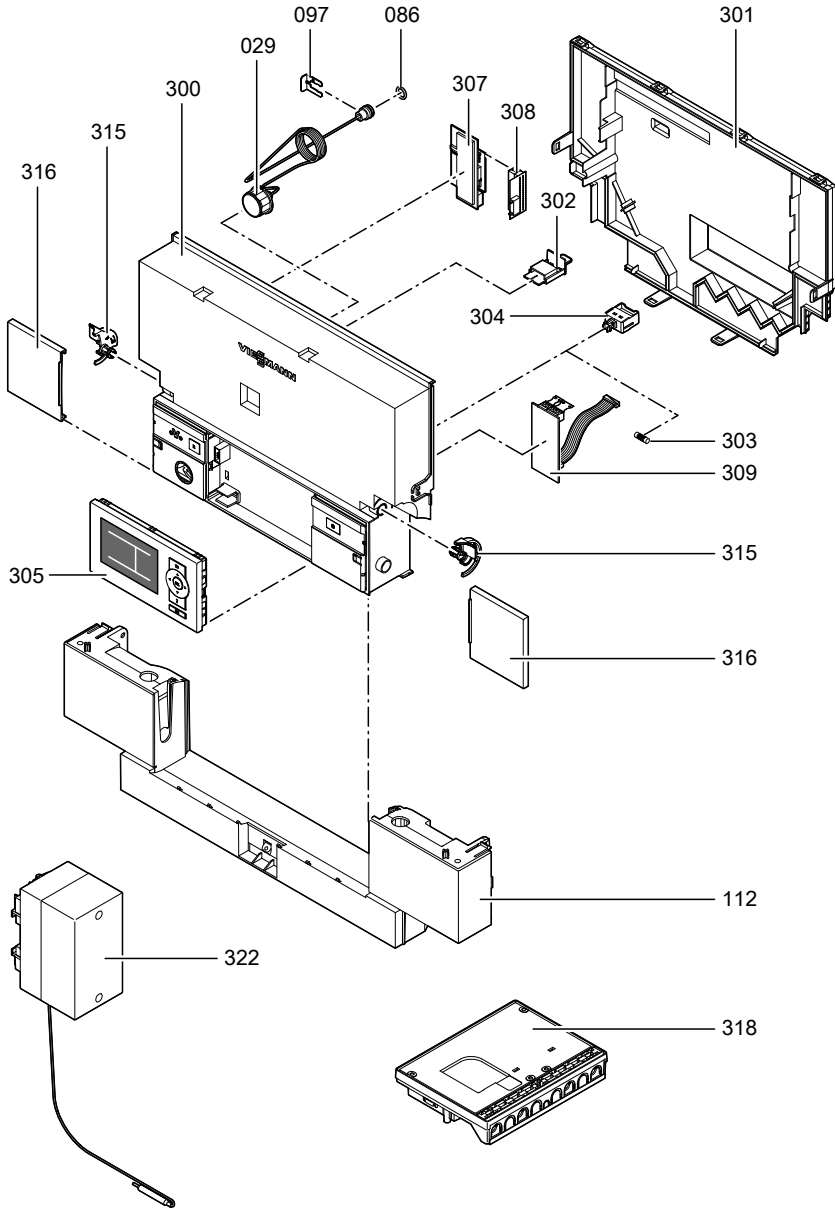

Parts lists (cont.)

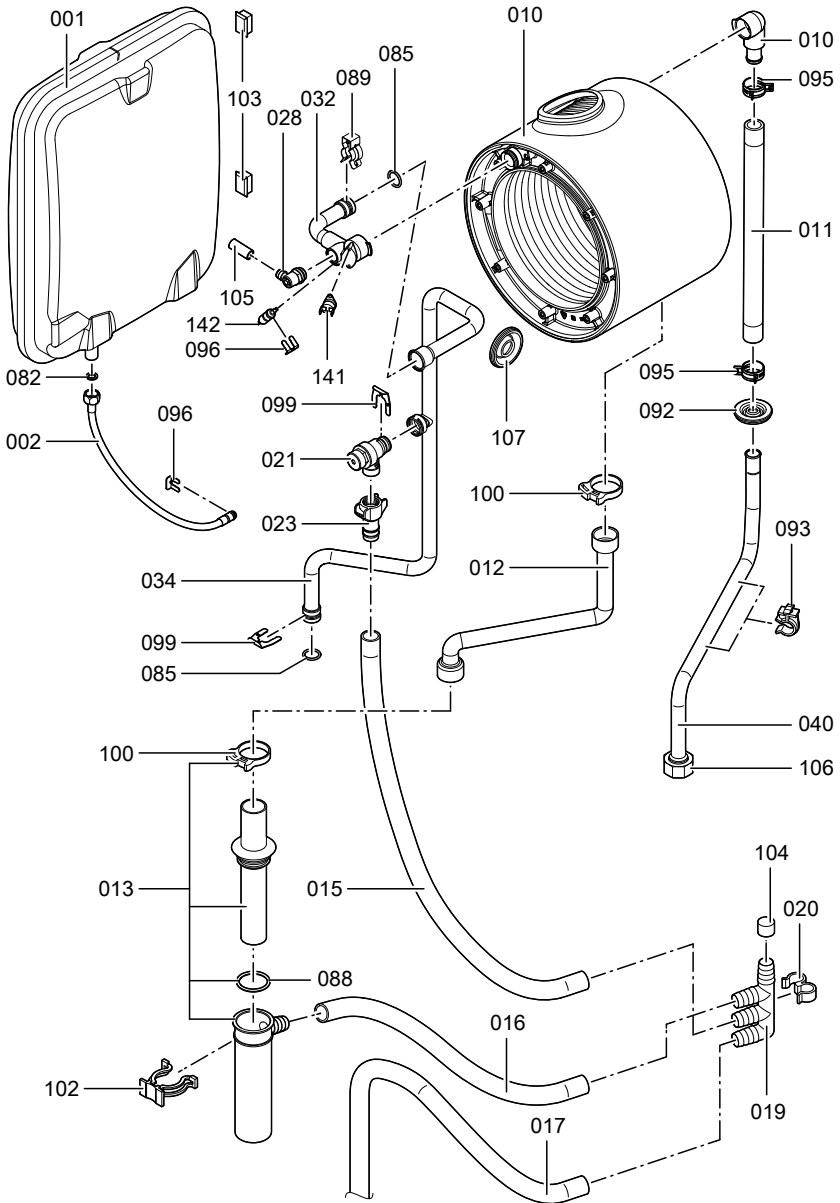

Parts lists (cont.)

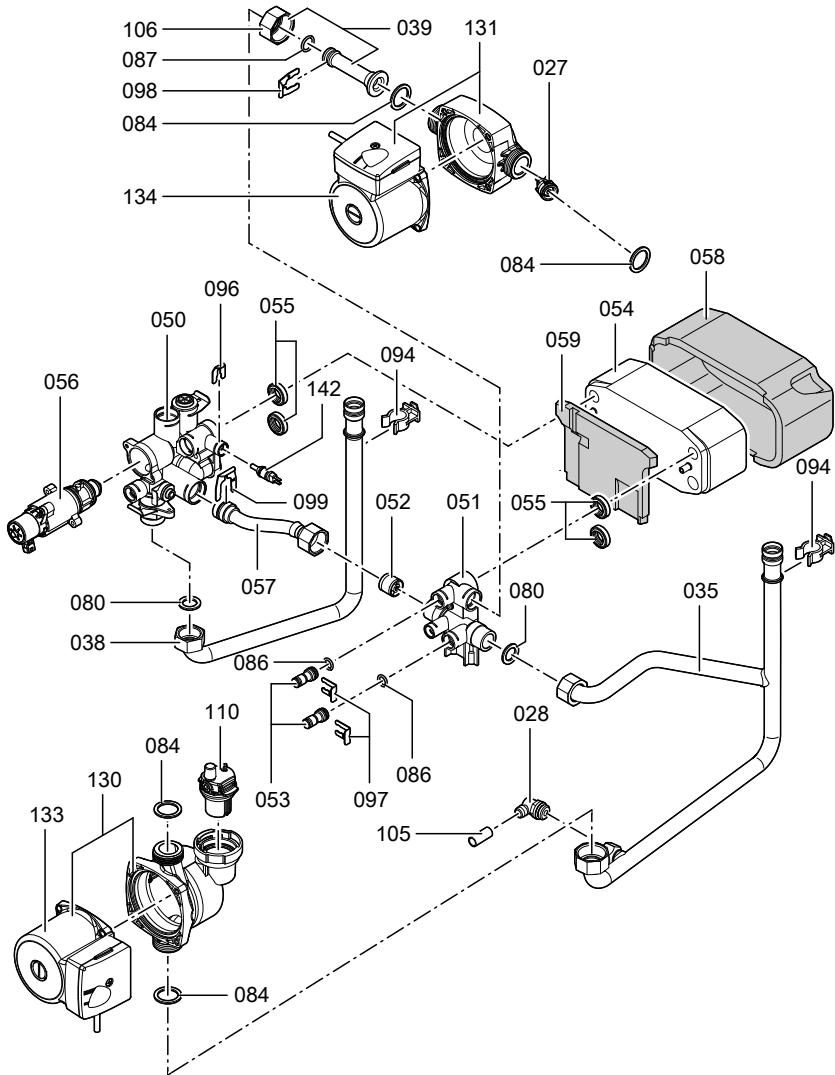

Parts lists (cont.)

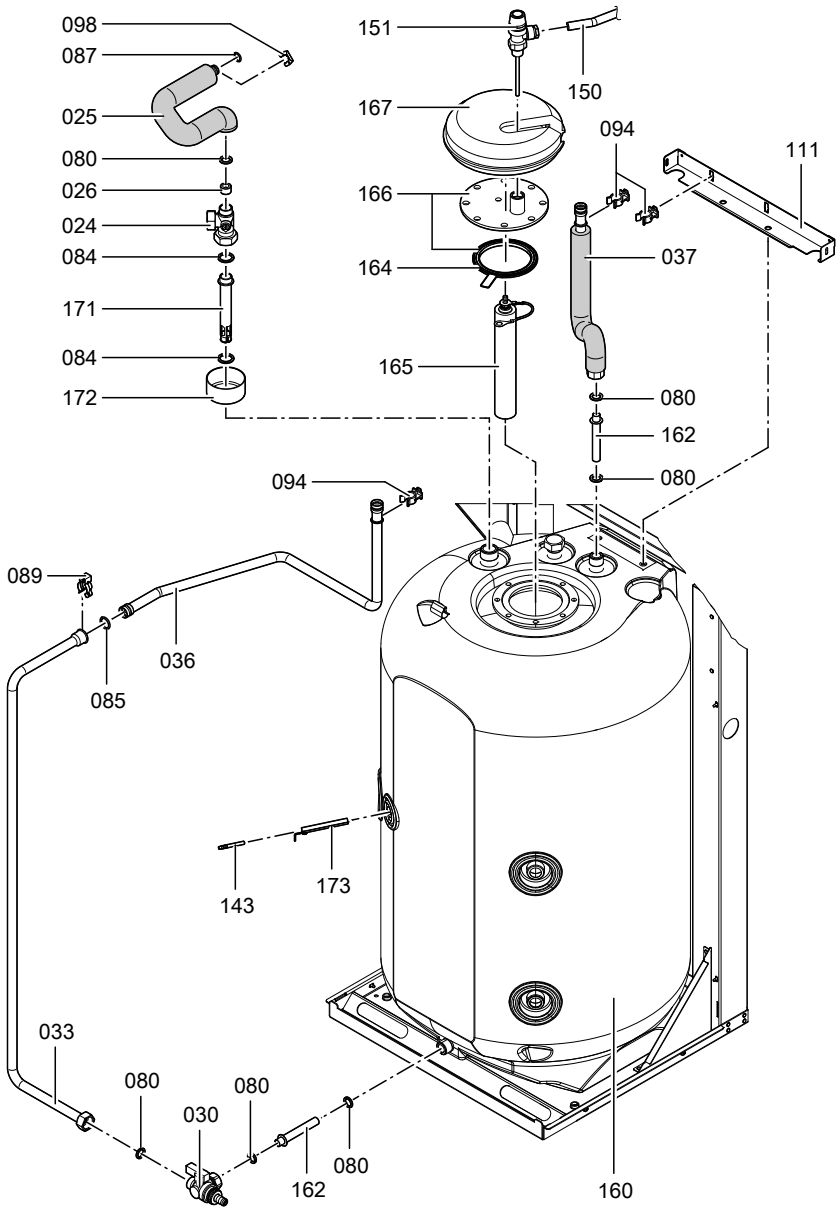

Parts lists (cont.)

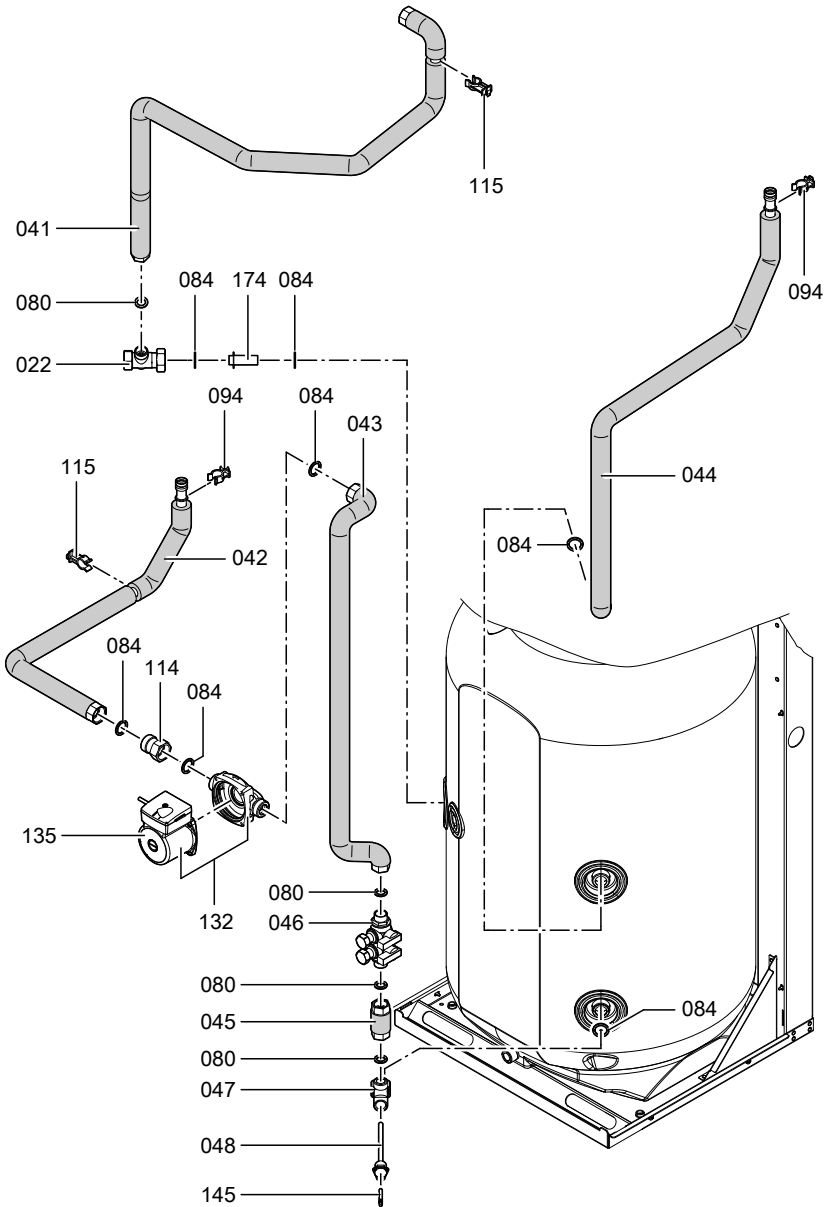

Commissioning/service reports

Setting and test values	Set value	Commissioning	Service
Date: By:			
Static pressure <i>mbar</i>	max. 57.5 mbar		
Supply pressure (flow pressure)			
<input type="checkbox"/> for natural gas E <i>mbar</i>	17.4-25 mbar		
<input type="checkbox"/> for natural gas LL <i>mbar</i>	17.4-25 mbar		
<input type="checkbox"/> for LPG <i>mbar</i>	42.5-57.5 mbar		
<i>Tick gas type</i>			
Carbon dioxide content CO₂			
■ at lower output <i>% by vol.</i>			
■ at upper output <i>% by vol.</i>			
Oxygen content O₂			
■ at lower output <i>% by vol.</i>			
■ at upper output <i>% by vol.</i>			
Carbon monoxide content CO			
■ at lower output <i>ppm</i>			
■ at upper output <i>ppm</i>			

Specification

Specification

Rated voltage	230 V	Electronic temperature limiter setting	82 °C
Rated frequency	50 Hz	Temperature limiter setting	100 °C (fixed)
Rated current	6 A	Line fuse (mains)	max. 16 A–
Protection class	I		
Protection	IP X 4 D to EN 60529		
Permissible ambient temperature			
■ during operation	0 to +40 °C		
■ during storage and transport	-20 to +65 °C		

Gas boilers

Rated output range			
at T_V/T_R 50/30 °C	kW	4.8 to 19	6.5 to 26
with DHW heating T_V/T_R 80/60 °C	kW	4.3 to 17.2	5.9 to 23.7
Rated thermal load range			
for central heating	kW	4.5 to 19.7	6.2 to 30.5
Power consumption (max.)			
Circulation pumps	W	231	231
Burner	W	40	40
Control unit	W	10	10
Connection values			
in relation to the max. load			
Natural gas E	m ³ /h	1.89	3.23
Natural gas LL	m ³ /h	2.20	3.75
LPG	kg/h	1.40	2.39
Product ID	C€-0085 BU 0051		

Note

The supply values are only for documentation purposes (e.g. in the gas contract application) or to estimate the supplementary volumetric settings. Because of factory settings, the gas pressure must not be altered from these settings. Reference: 15°C, 1013 mbar.

Declaration of conformity

Declaration of conformity for the Vitodens 242-F

We, Viessmann Werke GmbH&Co KG, D-35107 Allendorf, confirm as sole responsible body that the product **Vitodens 242-F** complies with the following standards:

DIN 4702-6	EN 55 014
DIN 4753	EN 60,335-1
EN 483	EN 60 335-2-102
EN 625	EN 61 000-3-2
EN 677	EN 61 000-3-3
EN 806	

In accordance with the following Directives, this product is designated **CE-0085**:

97/23/EC	2004/108/EC
90/396/EEC	2006/ 95/EC
92/42/EEC	

This product meets the requirements of the Efficiency Directive (92/42/EEC) for **condensing boilers**.

Allendorf, 1 May 2009

Viessmann Werke GmbH & Co KG



pp. Manfred Sommer

Manufacturer's certificate according to the 1st BImSchV [Germany]

We, Viessmann Werke GmbH&Co KG, D-35107 Allendorf, confirm that the product **Vitodens 242-F** complies with the NO_x limits specified by the 1st BImSchV paragraph 7 (2) [Germany].

Allendorf, 1 May 2009

Viessmann Werke GmbH & Co KG

A handwritten signature in black ink, appearing to read 'M. Sommer', written in a cursive style.

pp. Manfred Sommer

Keyword index

- A**
Acknowledging a fault display.....85
- B**
Boiler temperature sensor.....96
Brief scans.....81
Burner gasket.....36
Burner gauze assembly.....36
Burner removal.....35
- C**
Calling up fault messages.....85
Changing the language.....25
Checking the combustion quality.....47
Cleaning the combustion chamber...37
Cleaning the cylinder.....43
Cleaning the heat exchanger.....37
Code 1
■ Calling up.....61
Code 2
■ Calling up.....72
Coding during commissioning.....48
Combustion controller.....119
Commissioning.....24
Commissioning/service report.....135
Condensate drain.....39
Connection diagrams.....121
Control unit maintenance position.....93
Cylinder temperature sensor.....96
- D**
Diaphragm expansion vessel.....24
Draining the boiler
■ On the DHW side.....42
■ On the heating water side.....94
- E**
Electronic combustion controller.....119
Extension
■ external H1.....110
■ external H2.....111
■ internal.....108, 109
Extension kit for heating circuit with mixer104
External blocking.....113
External demand.....113
- F**
Fault codes.....86
Fault history.....85
Fault manager.....57
Fault memory.....85
Faults.....85
Fill function.....113
Filling the system.....24
Fitting the burner.....37
Flow temperature sensor.....96
Flue gas temperature sensor.....100
Function descriptions.....106
Function testing.....83
Fuse.....103
- G**
Gas supply pressure.....33
Gas train32
Gas type.....29
Gas type conversion.....30
- H**
Heating curve.....54
Heating curve level.....55
Heating curve slope.....55
Heating program changeover.....112
Heat-up time.....117
Hiding a fault display.....85
- I**
Ignition.....37
Ignition electrodes.....37
Ionisation electrode.....37

Keyword index (cont.)

L

LON.....56
 ■ Fault monitoring.....57
 ■ Setting subscriber numbers.....56
 LON communication module.....56
 LON subscriber check.....57

M

Magnesium anode
 ■ Checking the anode.....44
 ■ Checking the anode connection.....40
 ■ Replacing the anode.....44
 ■ Testing the anode current.....40
 Manufacturer's certificate138

O

Outlet temperature sensor.....99
 Output setting.....33
 Outside temperature sensor.....95

P

Parts list.....125
 Plate heat exchanger.....101
 Protective anode
 ■ Checking the anode.....44
 ■ Checking the anode connection.....40
 ■ Replacing the anode.....44
 ■ Testing the anode current.....40

R

Reduced room temperature.....56
 Reduced room temperature raising. 116
 Reducing the heat-up output.....116
 Reducing the heat-up time.....117
 Relay test.....83
 Remote control.....118
 Removing the front panels.....24
 Reports.....135

Resetting codes.....61, 72
 Room temperature adjustment.....55
 Rotational direction of mixer motor
 ■ Changing.....105
 ■ Checking.....104

S

Safety chain101
 Scanning operating conditions.....81
 Scanning operating data.....81
 Screed drying.....114
 Screed drying function.....114
 Setting the date.....26
 Setting the time.....26
 Siphon.....39
 Solar control module fuse.....104
 Specification136
 Standard room temperature.....55
 Static pressure.....32
 Supply pressure.....32
 System designs.....48
 System pressure.....24
 System schemes.....61
 System version.....49

T

Temperature limiter.....101
 Tightness test, balanced flue system.34

V

Venting.....26
 Venting program.....113
 Vitocom 300.....56
 Vitotronic 200-H.....56, 105

W

Wiring diagram.....121





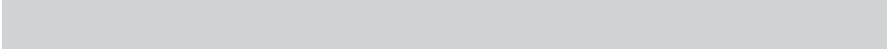



Applicability

Compact gas condensing boiler

Type FB2A	from serial no.
4.8 to 19 kW	7423 015 ...
6.5 to 26 kW	7374 980 ...

Viessmann Werke GmbH&Co KG
D-35107 Allendorf
Telephone: +49 6452 70-0
Fax: +49 6452 70-2780
www.viessmann.com

Viessmann Limited
Hortonwood 30, Telford
Shropshire, TF1 7YP, GB
Telephone: +44 1952 675000
Fax: +44 1952 675040
E-mail: info-uk@viessmann.com