

**GALAXIE
GALAXIE**

**246 &
246 'N'**

**COMBINED CENTRAL
HEATING BOILER
AND SPACE HEATER**

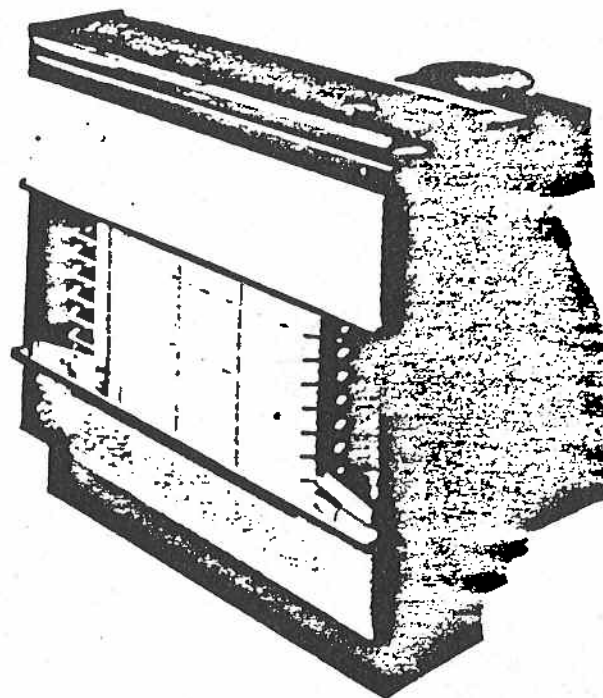

G.C. Nos.

44 315 15 Galaxie 246 (Cat. II TN)

44 315 16 Galaxie 246 'N' (Cat. IN)

INSTALLATION AND SERVICE INSTRUCTIONS

(To be left with the user or at the gas service meter)

GLOW-WORM



OVERALL DIMENSIONS

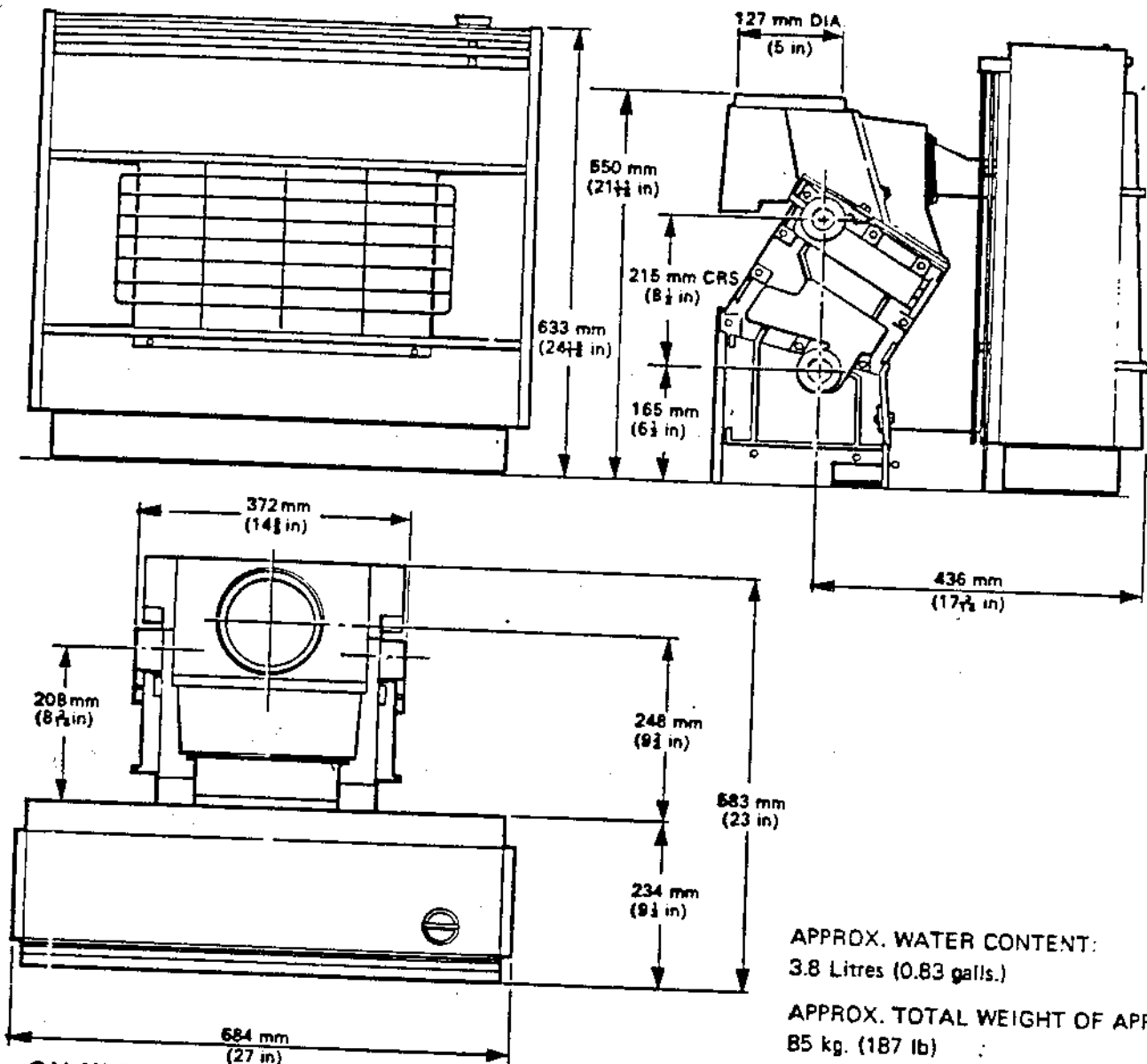

GALAXIE 246

Gas group	BOILER				FIRE			
	Injector		Pressure setting		Injector	Pressure setting		
	Furigas	Bray	mbar	in. w.g.	Bray	mbar	in. w.g.	
1st Family (Manufactured Gas)	G4	1 hole x 5.8mm dia.	Cat.37	5.0	2.0	Cat. 29 No. 900	4.0	1.6
	G5		No.500	5.9	2.4	Cat. 29 No. 900	4.8	1.9
2nd Family (Natural Gas)		5 hole x 1.6mm dia.	Cat.37 No.150	14.1	5.7	Cat. 16 No. 300	10.6	4.2

GALAXIE 246 'N'

IMPORTANT NOTICE: The GALAXIE 246 'N' is for use on natural gas only and CANNOT be used on any other gas.

Gas group	BOILER				FIRE		
	Injector		Pressure setting		Injector	Pressure setting	
	Furigas	Bray	mbar	in. w.g.	Bray	mbar	in. w.g.
2nd Family (Natural Gas)	5 hole x 1.6mm dia.	Cat.37 No.150	14.1	5.7	Cat. 28 No. 220	19.4	7.8

These instructions are applicable to both models. Where differences in procedure occur between the GALAXIE 246 and GALAXIE 246 'N', these are noted in the relevant section. If in doubt of the model, it may be identified from the data badge, visible on the lower L.H. side of the back panel when the casing is removed.

RATINGS (Both Models)

BOILER UNIT

Maximum Heat Input 17.9 kw (61,000 Btu/h).

Heat Output 13.5 kw (46,000 Btu/h).

GAS FIRE UNIT

Maximum Heat Input 6.15 kw (21,000 Btu/h).

SITE REQUIREMENTS

The Glow-worm GALAXIE 246 combined central heating boiler and radiant convector gas fire is delivered on site as three separate packages. Check that the unit delivered is suitably marked for your gas supply.

The boiler body and base is packed on a pallet, the boiler controls in one container and the fire assembly in a second container.

THE BUILDER'S OPENING

For all types of installation the GALAXIE 246 requires a standard sized builder's brickwork opening, irrespective of the type of fire surround or mounting used.

That is, a clear brickwork opening, measuring in plan 580 mm. (22¾ in.) wide x 359 mm. (14¼ in.) deep, inclusive of plaster finish with local infill pieces as shown. (See diagram 1.)

It is important that the back wall of the builder's opening is cleared of any adhesive debris (mortar, etc.) and that the actual gathering into the 229 mm. x 229 mm. (9 in. x 9 in.) chimney is at a minimum height of 914 mm. (36 in.) above hearth level.

The required holes for all heating, domestic hot water (and gas pipe where applicable) should be prepared as suggested in diagram 1.

The prepared boiler base must be flat and horizontal.

NOTES

1. All electrical wiring must be carried out by a qualified electrician.
All external components shall be of the approved type and shall be wired in accordance with the I.E.E. Regulations.
2. Electrical Supply 240V., 3A., 50Hz.
3. This boiler shall only be connected to a cistern water supply, with a head not exceeding 27 metres (ninety feet) and have an open vent in the system.
The appliance must be earthed and connections to the mains supply must be through a 3 amp fused double pole isolating switch or spur box, or an unswitched shuttered socket outlet and 3 amp fused 3-pin plug.
Heat resistant cable of at least 3 amp (16/0.20) capacity must be used for all wiring to control box.

5. THE INSTALLATION OF THIS APPLIANCE MUST BE CARRIED OUT BY A QUALIFIED INSTALLER AND THE HEATING SYSTEM MUST BE IN ACCORDANCE WITH BRITISH STANDARD BS5376 PART 2, CODE OF PRACTICE CP3006, CP331 PARTS 2 AND 3, B.S.5440:1 & 2, THE BUILDING REGULATIONS, GAS COUNCIL PUBLICATION "VENTILATION REQUIREMENTS OF GAS APPLIANCES 1970, THE REQUIREMENTS OF THE LOCAL GAS REGION, THE LOCAL AUTHORITY AND WHERE APPLICABLE THE GAS SAFETY REGULATIONS 1972".

DIAGRAM 1

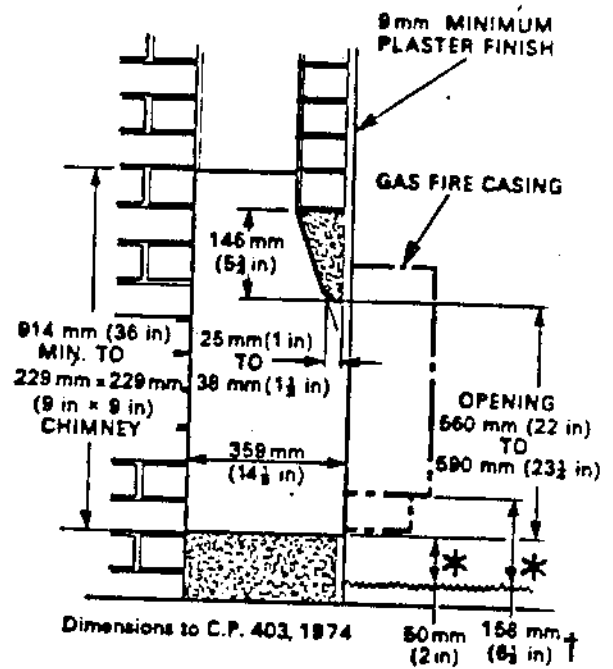

N.B. * Minimum dimensions. These dimensions refer to minimum clearance after carpet or any floor covering has been fitted.
† (It may be necessary to allow up to 50 mm (2 in) additional height from actual floor level if a deep pile carpet is fitted below the fire).

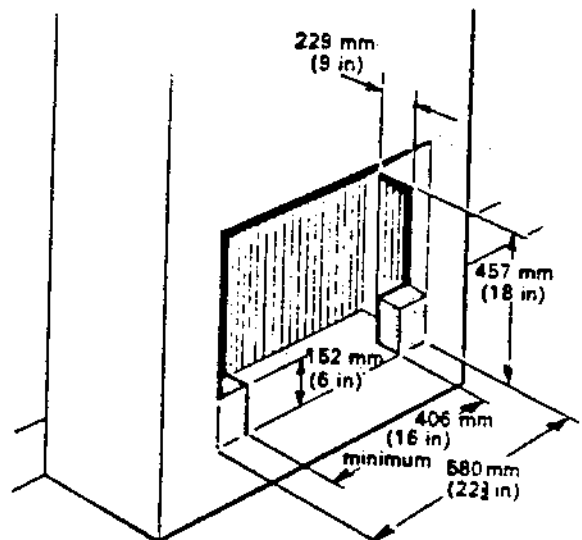

Builders brickwork opening showing access in the breastwork for pipes (which may be either right-hand or left-hand side). Illustration for wall mounting only. It is suggested that the dotted areas are filled with a part brick to obscure view of pipes etc.

TYPES OF FIXING

a. Wall Mounted (that is, without tiled surround).

The builder's opening dimensions given earlier still apply. The frontal opening required is 580 mm. wide x 590 mm. high (22 $\frac{3}{4}$ in. x 23 $\frac{3}{4}$ in.), which means that a lintel must be fixed at a height of 590 mm. (23 $\frac{3}{4}$ in.) above the base of the builder's opening, and the wall is plastered up to the two sides and top to form the 580 mm. x 590 mm. frontal access. Wall decoration can be taken right up to the sides of the opening, no further register or closure plate is required.

In this type of installation it is quite normal to carpet the floor directly below the fire, and for this reason it is necessary to arrange the floor of the builder's opening at a minimum height of 107 mm. (4 $\frac{1}{4}$ in.) above room floor level to allow the necessary minimum height of 158 mm. (6 $\frac{1}{4}$ in.) from floor level to the underside of the fire casing, after carpet or floor covering has been fitted to avoid overheating of the carpet or unprotected floor fabric.

Under no circumstance must the prepared base in the brickwork setting be closer to the room floor level, unless a fireproof and insulating protection plate or base with minimum dimensions of 700 mm. (27 $\frac{1}{2}$ in.) wide x 300 mm. (12 in.) deep x 12.5 mm. ($\frac{1}{2}$ in.) thick, be fitted below the fire.

b. Tile Surround Fixing

The GALAXIE 246 can be installed with the tiled surround and hearth in position.

All tile surrounds vary in dimensions, it is important therefore to check that the thickness of the existing surround does not bring the boiler too far forward so that it fouls the flue. It must also have a flat face.

The minimum opening required in the tiled surround is 406 mm. (16 in.) wide x 560 mm. (22 in.) high. The maximum opening permitted is 580 mm. (22 $\frac{3}{4}$ in.) wide x 590 mm. (23 $\frac{3}{4}$ in.) high.

The prepared boiler base of the builders opening **MUST** be level with or above, the top surface of the hearth to give a minimum gap of 21 mm ($\frac{1}{2}$ in.) from the bottom of the fire plinth to the hearth. See diagram 2.

THE FLUE

The general recommendations of B.S.5440:1 should be observed. In common with all central heating boilers the integral draught diverter on the GALAXIE 246 boiler makes the combustion performance independent of conditions in the chimney flue. It is essential that the flue be an efficient ventilator for the flue products to ensure a trouble-free installation, and of at least 3 metres (10 feet) equivalent height.

An existing brick chimney must be thoroughly swept and must be lined with a British Gas approved liner sleeve of 127 mm. (5 in.) dia., which must be connected and sealed directly into the flue outlet socket of the boiler. The termination of the liner at chimney top must be adequately sealed and clamped, using proprietary fittings appropriate to the flue liner used. (See diagram 2.)

THE EXISTING FLUE MAY NOT BE COMPLETELY SOUND, TO OVERCOME ANY DOUBTS IN THIS RESPECT ADDITIONAL SEALING MUST BE CARRIED OUT BETWEEN THE BASE OF THE CHIMNEY AND THE FLUE LINER, AS RECOMMENDED IN DIAGRAM 2.

A newly-built chimney can be lined with a moisture resistant lining, such as salt glazed pipe, 152 mm. (6 in.) dia.

In the case of a 'salt glazed' lined flue, it is recommended that a short length of flue pipe, possibly flexible metallic as described above, be fixed and sealed to the boiler flue socket and made good with asbestos rope packing into the chimney liner. (See diagram 3.)

All flues must terminate in a British Gas approved terminal. Your local Gas Region will be pleased to advise.

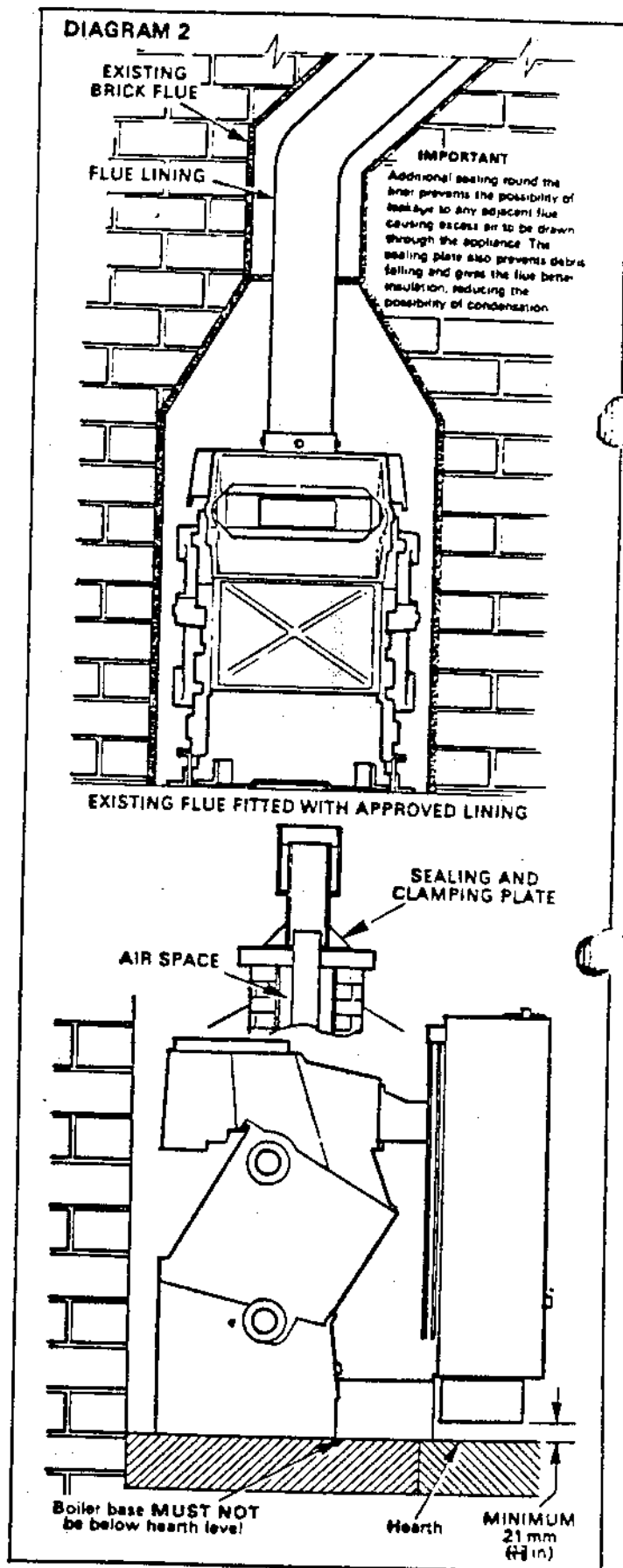

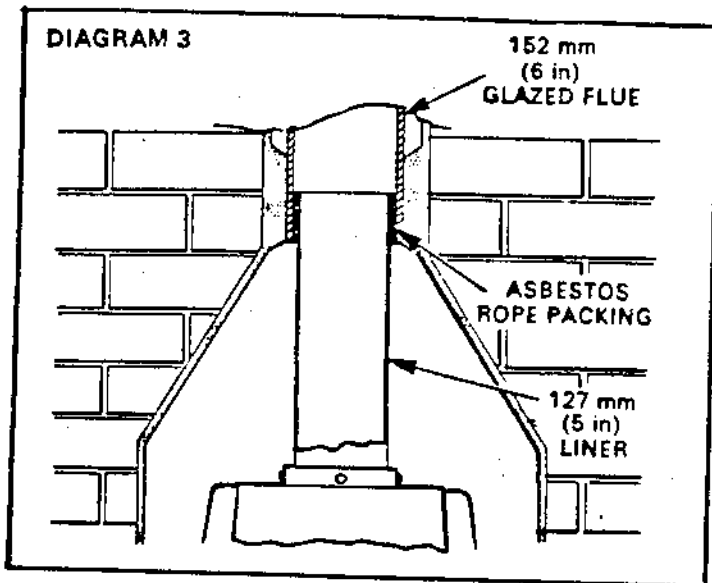

ROOM VENTILATION

It is important that the room in which the GALAXIE 246 is fixed must have adequate air inlets to ensure correct operation of the appliance. A permanent air vent of effective area 77 cm^2 (12 in^2) should be fitted. It may communicate direct with outside or with an internal room or space (such as a hall) which is itself provided with a permanent air vent of the same effective area. The permanent air vent should be located in a position which minimises nuisance to occupants due to draughts.

HEATING SYSTEM

The design and installation of the system should be in accordance with British Standard Code of Practice CP 3006. When used to supply a domestic hot water system combined with a central heating circuit, the hot water cylinder must be indirect. The boiler should never be used on a direct domestic hot water system.

DRAINING

Key operated taps to BS 2879 should be fitted in accessible positions to facilitate complete emptying of the system, except small dips under doors, etc.

SAFETY VALVE

When fitted it should be adjacent to the boiler on the flow pipe. It should not be possible to isolate the valve from the boiler by any intermediate cock.

BOILER CONNECTIONS

The boiler body has two Rp1 (1 in. BSP) tappings on each side.

GAS CONNECTION

The gas installation should comply with the recommendations of CP 331, Parts 2 and 3. The gas supply and meter must be large enough to supply the boiler, together with any other gas appliance connected to them. If in doubt, your local Gas Region should be consulted.

If the gas supply is entering from the right hand side of the appliance, the gas supply should be laid before the boiler is positioned.

If the builders opening and flue were previously used with a solid fuel appliance, the gas supply pipe within the opening should be protected. A suitable method is to wrap with PVC tape.

STAGE 1

INSTALLATION PROCEDURE

It is assumed that the builder's opening has been prepared as described previously.

IMPORTANT

Remove the combustion chamber front cover and extension piece assembly from the boiler body before taking the boiler from the wooden pallet by removing the two slotted hex. head screws and washers securing it to the boiler.

Remove the boiler body and base assembly from its packing and check that the three flueway baffles have not become dislodged in transit and are pushed firmly down into the flueways. (See diagram 4.)

Place the boiler in its approximate position, centrally in the builder's opening. The gas fire flue off-take should not be used to lift the boiler. From the fire assembly container remove the formed steel channel, the sheet steel angled template and plastic bag containing screws, nuts and metal Rawlplugs. Attach the gas fire support channel to the top of the gas fire flue duct using the two M6 x 12 mm. long hex. hd. screws, nuts and shakeproof washers. Insert the screws upward through the flue duct into the channel so that the nut and shakeproof washer are uppermost. (See diagram 5.) Make sure that the two captive nuts are on the front face of the channel and that it is parallel with the front face of the flue duct. Check that the front face of the channel overhangs the front face of the flue duct by 3 mm., as shown in diagram 5.

The gas fire support channel should not be used to lift the boiler.

Offer one end of the flue liner into the boiler flue outlet, mark off and pierce three holes to suit the setscrews in the flue socket, then fit the flue liner into the chimney — leaving the lower pierced end approximately 525 mm. (20½ in.) above hearth level, make good at chimney top and trim off any surplus liner. (See diagram 2.)

Re-fit the combustion chamber front cover temporarily with the two slotted hex. head screws and washers previously removed.

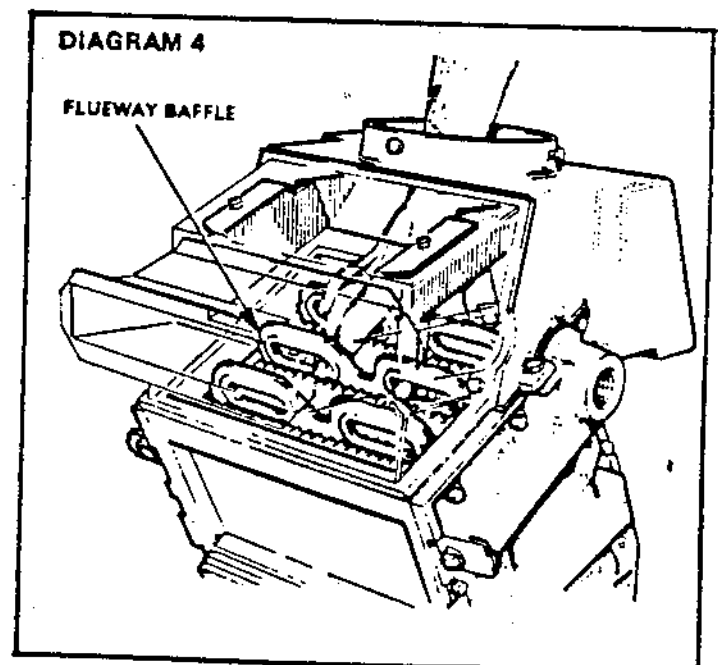

STAGE 2

BOILER FIXING

Offer up the angle template, as shown in diagram 5, so that the fire support plate is correctly aligned to the finished face of the plastered wall surface or tiled surround. This will ensure that the gas fire rear panel is fitted in the correct position. Pack under the full width of the boiler base, front or rear as required, to ensure that the boiler is located in the correct position.

After positioning the boiler use the level adjusting screws shown in diagram 5 to align the gas fire support plate and boiler combustion chamber extension, front to rear and across the width, with the base of the builder's opening.

Levelling screws are for fire support purposes and should only be used after levelling boiler by packing, as required. When adjusted lock up the screws with the locknuts provided. If further packing up at the front or rear is required, it must be fitted under the full width of the boiler base.

Ensure that the boiler is central in the builder's opening. With the boiler in position, drill through the holes in the brackets each side of the boiler base to take the metal Rawlplugs, and firmly secure the base to the hearth with the 2 in. x No. 12 wood screws and washers provided.

NOTE.—There should be sufficient tolerance in this fixing to allow final adjustment prior to completing the installation. Re-check from time to time with the template, as described earlier, to see that the boiler has not become mis-aligned.

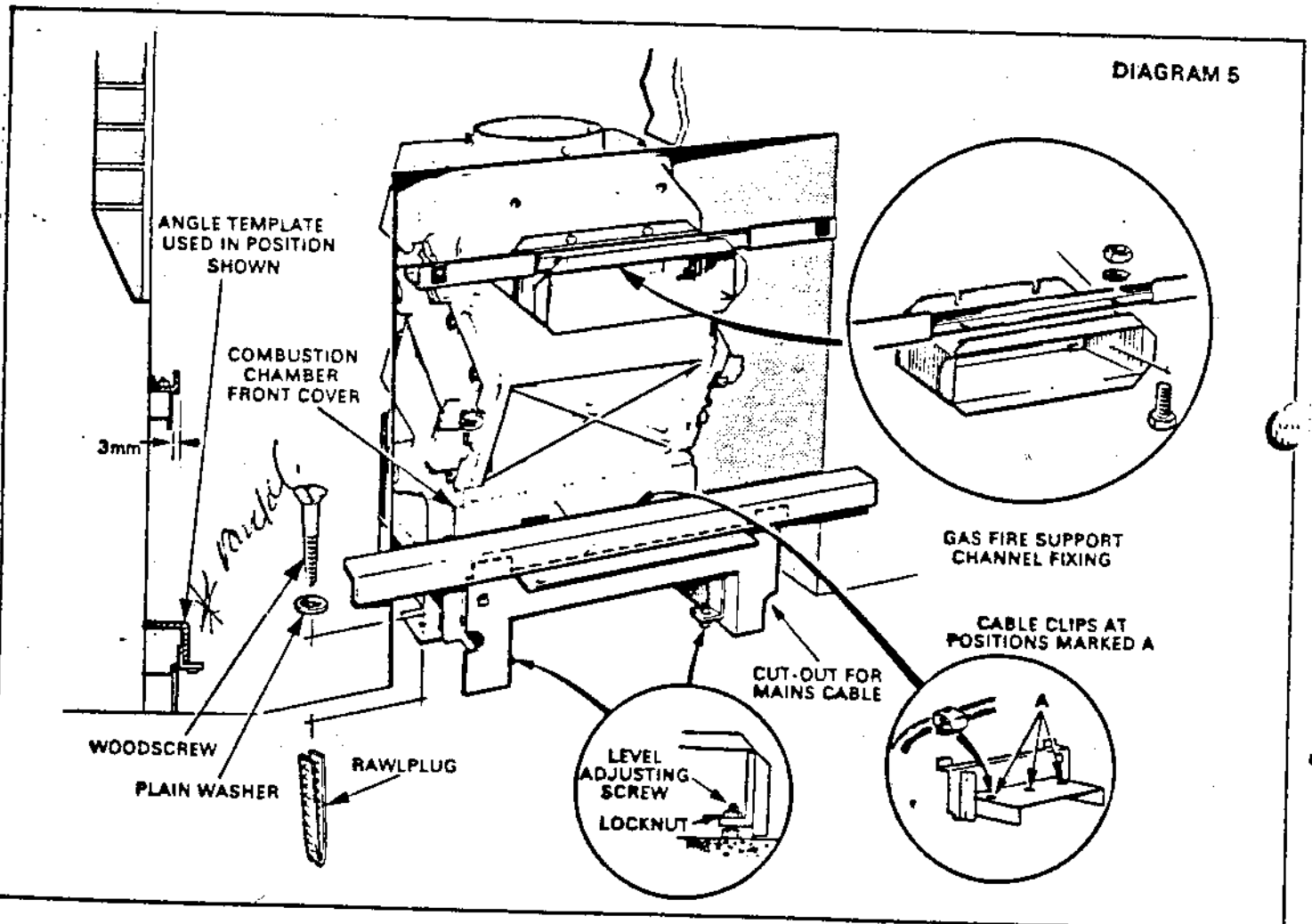

STAGE 3

WATER CONNECTIONS

All water pipes to the boiler can now be installed (see diagram 6).

IT IS EXTREMELY IMPORTANT THAT NO SERVICE PIPES CROSS THE FRONT OF THE COMBUSTION CHAMBER FRONT COVER AND FLUE COLLECTOR, AS THIS WOULD MAKE THE REMOVAL OF THESE COVERS FOR SERVICING IMPOSSIBLE.

No pipework should obscure the bottom of the draught diverter, the phial pocket, or the 1/2 in. BSP plug in the boiler body.

Flush the whole of the system, then fill and vent.

Check for water leakage.

All pipes within the fireplace opening should be protected.

A suitable method is to wrap with PVC tape.

Pumped heating with gravity hot water.

It is important that the scheme illustrated in diagram 6 is adopted when the connections are being prepared. The thermostat phial pocket must be fitted into the same side of the boiler as the heating flow connection. The connections may be fitted on opposite sides to that shown, but always in the same relative positions, including the thermostat phial pocket.

Pumped heating and hot water

Where single flow and return is taken from the boiler, the thermostat phial pocket must be on the same side as the flow connection is made (see diagram 6). It is important that all connections are made as illustrated in diagram 6. The connections may be fitted on opposite side to that shown, but always in the same relative positions, including the thermostat phial pocket.

DIAGRAM 6

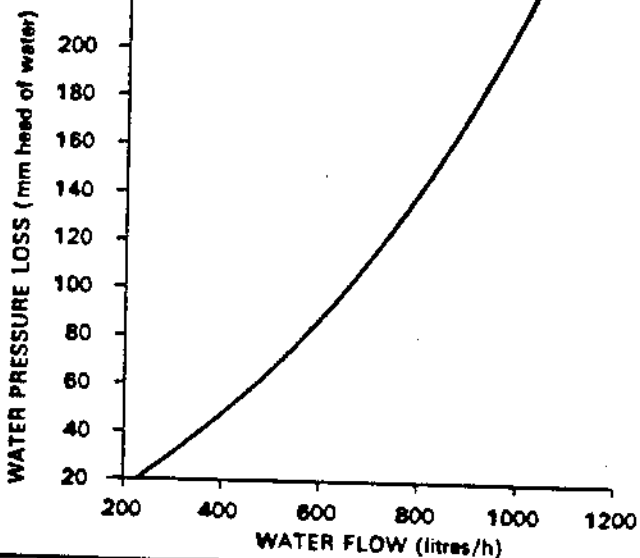
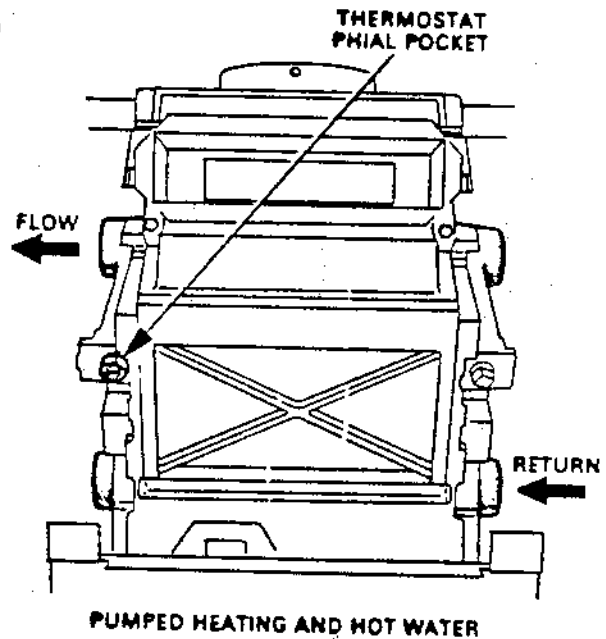
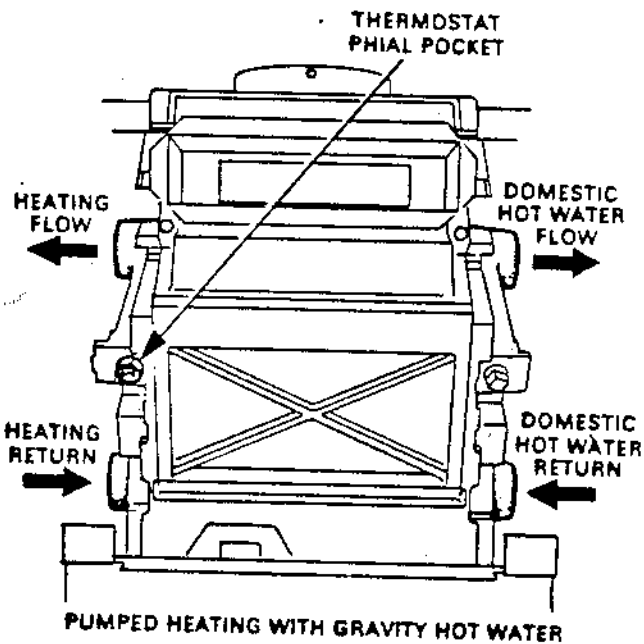

CIRCULATING PUMP

The pump should preferably be fitted in the flow from the boiler. If required, it may be fitted in the return.

Boiler Fixing—continued

Use the installation template from time to time to check that the setting has not been disturbed and correct as required.

Fit the lower end of the flue liner into the flue socket, secure with setscrews and seal with fire cement.

STAGE 4

CONTROLS

Remove the two slotted hex. hd. screws and washers securing the combustion chamber front cover and extension piece assembly to the boiler body and remove the cover assembly.

Remove the controls and burner assembly from its packing, unscrew the two hex. hd. screws holding the burner supply pipe securing strap to the electrical control box support bracket.

Place the electrical control box and burner support tray assembly on to the two studs in the boiler base. Secure with the two M6 hex. nuts provided. Take the burner and gas valve assembly and place into position in the burner base, entering the burner stub end into the location hole at the rear of the burner support tray, taking care not to disturb or damage the pilot burner or electrode. Ensure that the burner bars are horizontal then secure the assembly to the electrical control box support bracket with the two hex. hd. screws previously removed.

Check the boiler ignition electrode position relative to the pilot burner (see diagram 7).

DIAGRAM 7

BOILER PILOT IGNITION ELECTRODE

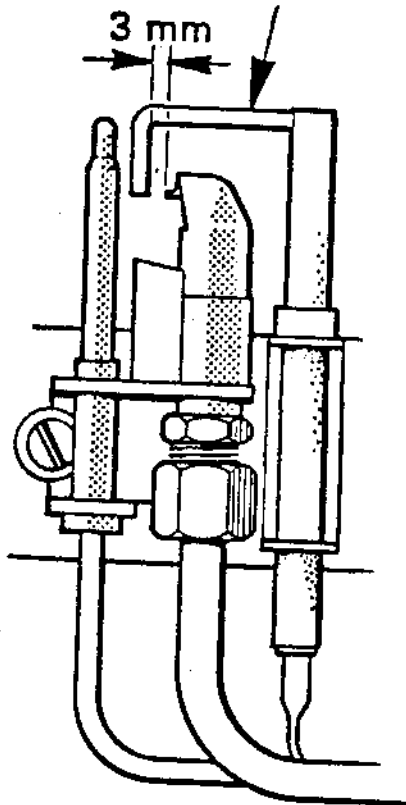

The gas service pipe run can now be made and connected to the union cock which is packed loose within the fire assembly carton. Assemble the cock to the gas valve in the position shown in diagram 17 and tighten the union nut.

The service can now be connected, care being taken to ensure that the service pipe does not impose strain upon the union as this may cause mis-alignment in the build-up.

Re-fit the combustion chamber front cover and extension assembly, ensuring an airtight seal between the cover and the boiler base, with the two M6 hex. hd. screws and washers previously removed.

Ensure that the gas service tap is in the 'OFF' position (see diagram 8), and check for gas soundness using soap solution.

DIAGRAM 8

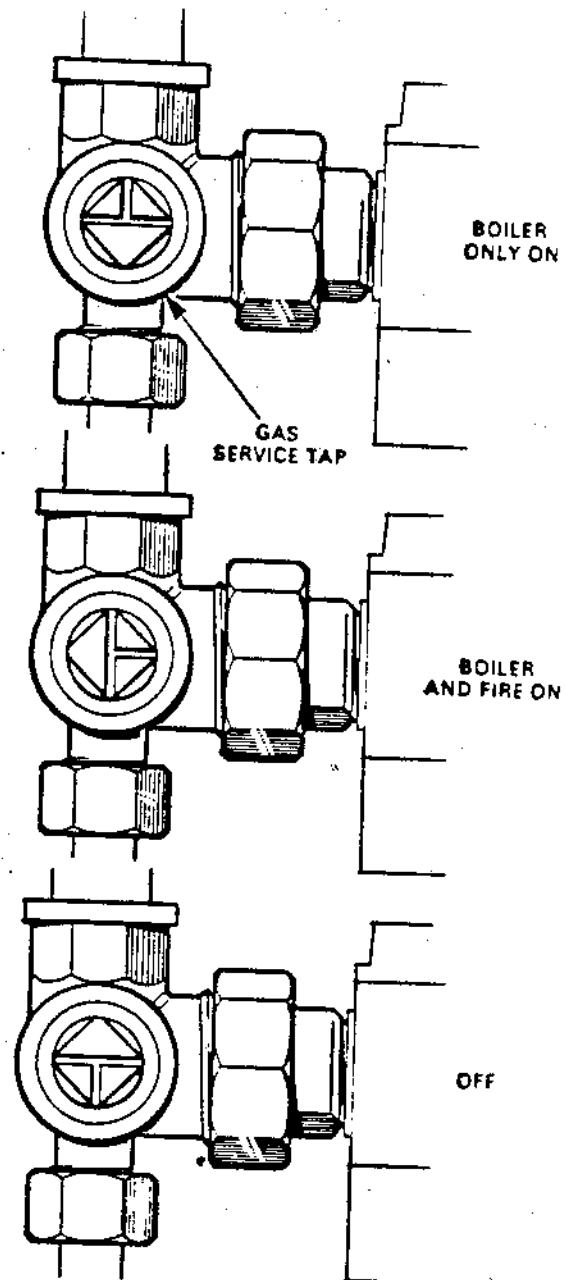
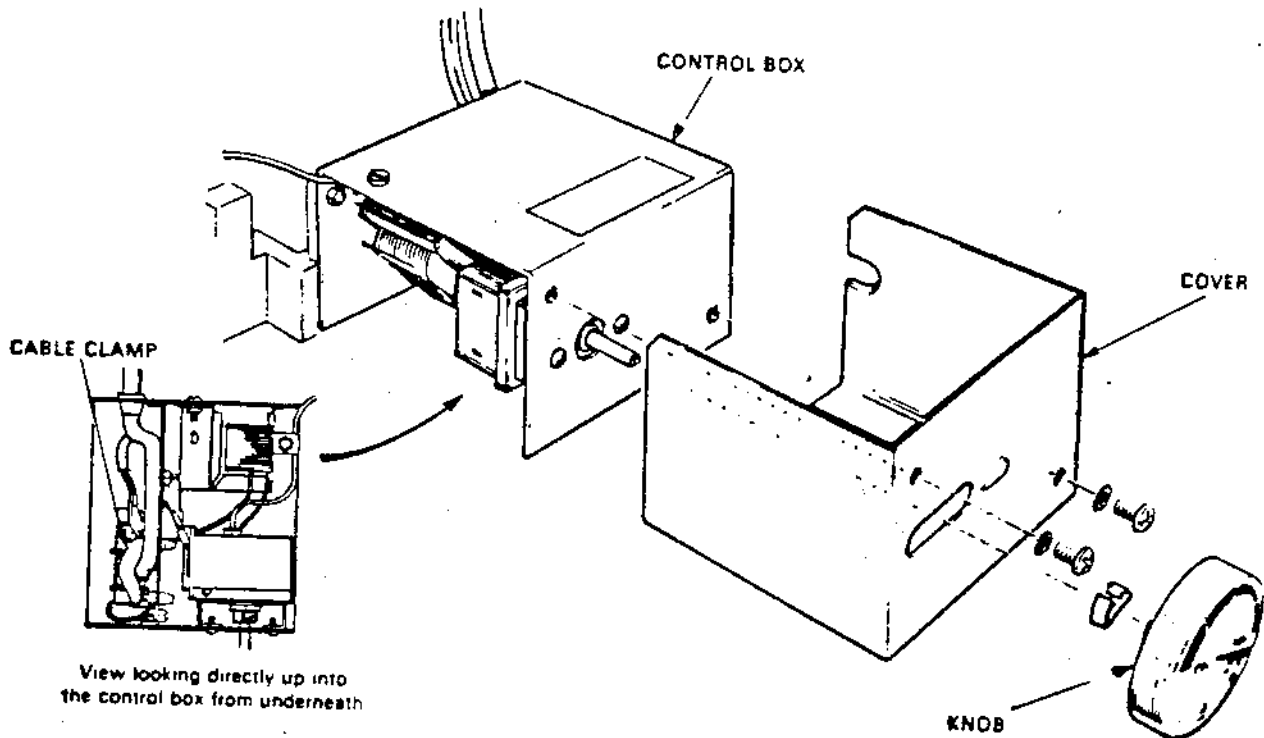

DIAGRAM 9



STAGE 5

ELECTRICAL WIRING

Complete the wiring to the control box.

NOTE.—The mains cable must not cross the fire opening. If concealed wiring is required, i.e. the supply from within the fire opening, for a cable coming from the left-hand side of the opening, safely position the cable away from hot surfaces by leading it across the front of the combustion chamber extension (see diagram 5), using the three cable clips supplied to fix it at the positions marked 'A'.

A cable entering from the right-hand side of the opening should pass via the cut-out at the bottom right-hand side of the extension piece (see diagram 5).

- a. Remove the boiler thermostat control knob by pulling from its spindle. (See diagram 9.)
- b. Remove the two Pozidriv pan hd. screws and shake-proof washers securing the cover to the control box and remove the cover.
- c. Bring the mains cable into the control box through the lower grommet in its rear surface. Slacken off the screws holding the mains cable clamp, pass the mains cable through the clamp and connect the three wires to the appropriate terminals in the terminal strip. See diagram 10. Tighten the screws holding the mains cable clamp.
- d. Complete the remainder of the wiring leading all cables in through the grommets, see diagrams 10 to 16, replace the control box cover and screws, then push the boiler thermostat control knob on to its spindle. Reconnect the ignition lead to the spark generator and the gas valve leads to the gas valve.

- e. Fit the boiler thermostat phial into the phial pocket. Ensure that it is inserted **fully** into the pocket and **retained with the fix provided**. The capillary should be positioned to pass vertically down the side of the boiler and then horizontally along the base unit.

NOTE.—When the thermostat phial is fitted on the left-hand side, route and secure the capillary as shown in diagram 17, using the clip provided.

X

WIRING INSTRUCTIONS FOR CONTROL BOX

THE INSTALLER IS REQUESTED TO ADVISE THE USER OF THE CONTROLS SCHEME USED WITH THIS APPLIANCE AND TO GIVE GUIDANCE ON THE OPERATION OF THE CONTROLS.

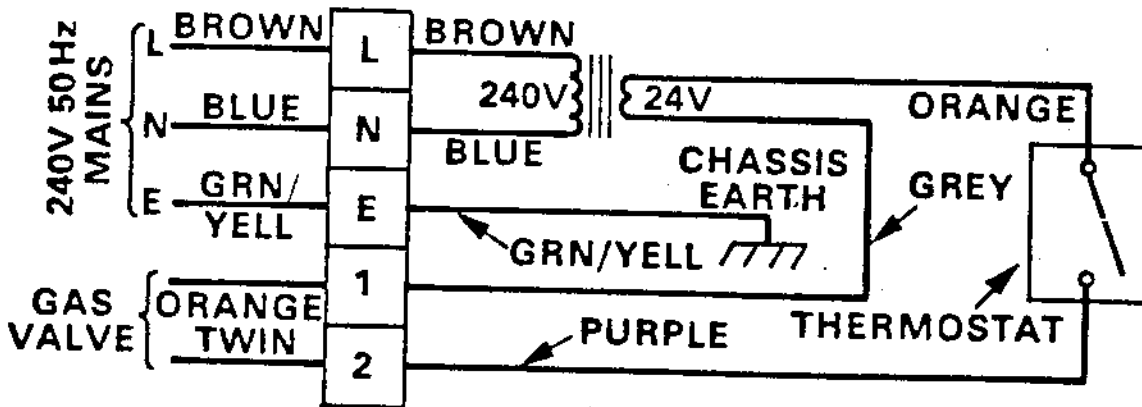

NOTE:—
ELECTRICITY SUPPLY MUST BE
240 V, 3A, 50 Hz.
IT IS ESSENTIAL THAT A 3-AMP FUSE
IS FITTED INTO THE "LIVE" WIRING
BETWEEN THE SUPPLY AND THE
BOILER

WIRING DIAGRAM FOR CONTROL BOX

STAGE 6

INITIAL LIGHTING AND ADJUSTMENT OF BOILER

CAUTION.—The following procedure should be carried out by a qualified gas service engineer. The pipes and fittings to the gas control and burner and to some extent the gas pipe to the appliance will contain an appreciable amount of air. It is, therefore, necessary to purge the air from the pipes before the appliance can operate normally. Purging should be carried out as described in CP331, Part 3. Identify the boiler controls with relevant details on diagram 17.

Set all the controls to the 'OFF' position.

Turn the gas service tap to the "Boiler only on" position (see diagram 8). Remove the gas pressure test nipple screw 'S' (see diagram 17), and fit a suitable pressure gauge. Switch on the electrical power to the boiler. Ensure that the boiler thermostat knob 'C' is in the 'OFF' position. Set the boiler gas valve control knob to the pilot position, depress and hold in. Press and release the spark generator button 'B', a single spark should ignite the pilot burner. Hold the boiler gas valve knob in for one minute. The boiler gas valve control knob can then be released.

Adjust the pilot flame as necessary at the gas valve adjustment screw 'M' (see diagram 17), after removing the cover screw, until a pilot flame length of 25 mm. (1 in.) for Natural Gas or 16 mm. ($\frac{1}{2}$ in.) for Town Gas is obtained (see diagram 7). The thermocouple should be enveloped 10 mm. to 13 mm. ($\frac{3}{8}$ in. to $\frac{1}{2}$ in.) by the pilot flame. Turn anti-clockwise to increase. When the pilot is stable and set, turn the boiler gas valve control knob 'A' to the 'ON' position and ensure that all other controls are set for heating. Then turn the boiler thermostat control knob 'C' to 'MAX'. The burner should light smoothly and the primary cones should be well defined when the pressure setting has been adjusted at the governor screw 'L' to the correct gas pressure, see page 2.

Turn the boiler thermostat to 'OFF'. Remove the pressure gauge and replace the gas pressure test nipple screw.

Turn boiler thermostat to 'MAX' and allow system to reach maximum operating temperature. Examine the whole system for leaks, turn boiler thermostat to 'OFF' and then drain whilst still hot to give a final effective flushing. Re-fill and vent. Give final examination for leaks.

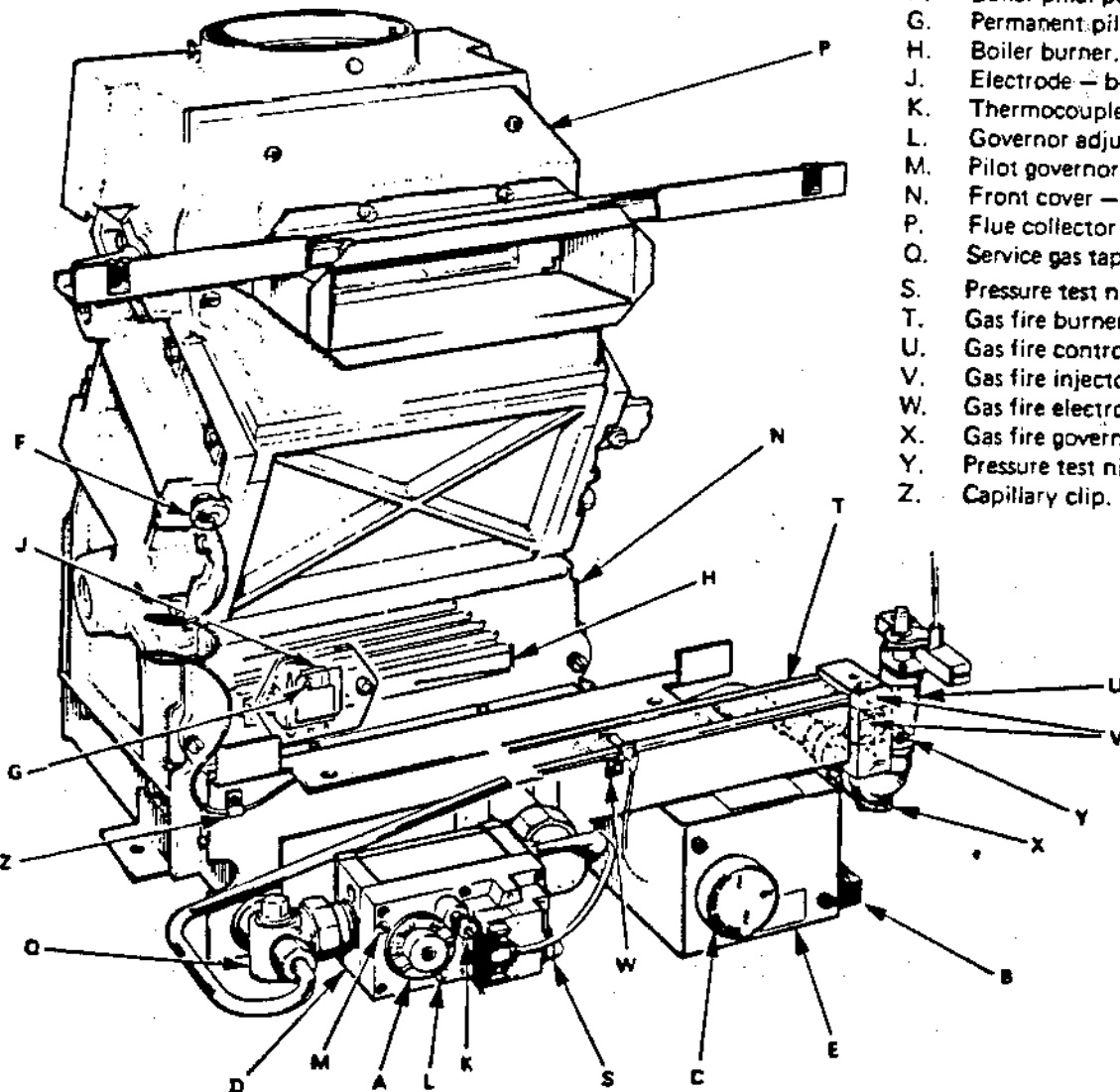

Key

- A. Gas control knob.
- B. Spark generator — boiler.
- C. Thermostat control knob.
- D. Gas valve.
- E. Electrical control box.
- F. Boiler phial pocket.
- G. Permanent pilot — boiler.
- H. Boiler burner.
- J. Electrode — boiler.
- K. Thermocouple union.
- L. Governor adjustment — boiler.
- M. Pilot governor adjustment.
- N. Front cover — combustion chamber.
- P. Flue collector — front.
- Q. Service gas tap.
- S. Pressure test nipple — boiler.
- T. Gas fire burner.
- U. Gas fire control tap and spark generator.
- V. Gas fire injectors.
- W. Gas fire electrode.
- X. Gas fire governor (Galaxie 246 only).
- Y. Pressure test nipple — fire.
- Z. Capillary clip.

DIAGRAM 17

STAGE 7

INSTALLATION CONTINUED

Remove the gas fire unit from its packing by opening the four carton flaps outward and turning the complete unit and carton up the correct way. The carton can then be lifted off leaving the fire unit standing in its base packing. Remove the dress guard by easing it forward in the centre until the side location wires are clear of the reflector and pulling forward at the top and upward. Remove the radiant packing piece and the radiants. Lift the gas fire unit from its base packing and lay the assembly on its back on the floor. The casing can now be removed. First remove the gas fire control knob by pulling it off the spindle. Unscrew the two lower casing securing screws, positioned just below the bottom reflector strip (see diagram 18). Pull the bottom of the casing forward slightly and raise the casing approximately 13 mm. (½ in.), easing the bottom forward and lifting vertically to clear the spindle.

Unscrew the four Pozidriv pan head screws securing the inclined upper casing protection plate to the sides of the rear panel and remove the protection plate.

Remove the two louvres from the packing and fit on to the sides of the fire heat exchanger and rear panel assembly by engaging the louvre brackets in the slotted locations in the rear panel (see diagram 19).

Lower the fire heat exchanger and rear panel assembly on to the combustion chamber extension piece tilting the top of the assembly forward slightly, ensuring that the dowels on the bottom of the heat exchanger assembly locate in the holes in the extension piece, and incline backward to make a seal between the fire flue spigot and the boiler flue mouth. Secure the fire heat exchanger assembly to the fire support channel with the two M6 x 20 mm. lg. slotted hex. head dogpoint screws and M6 large dia. plain washers provided in positions shown in diagram 19. Connect the gas fire supply pipe to the union gas cock at the left hand side of the fire by means of the tubing nut.

Check that all the joints on the gas fire supply pipe are secure and gas tight.

Re-fit the upper casing protection plate to the sides of the rear panel using the four Pozidriv pan hd. screws previously removed.

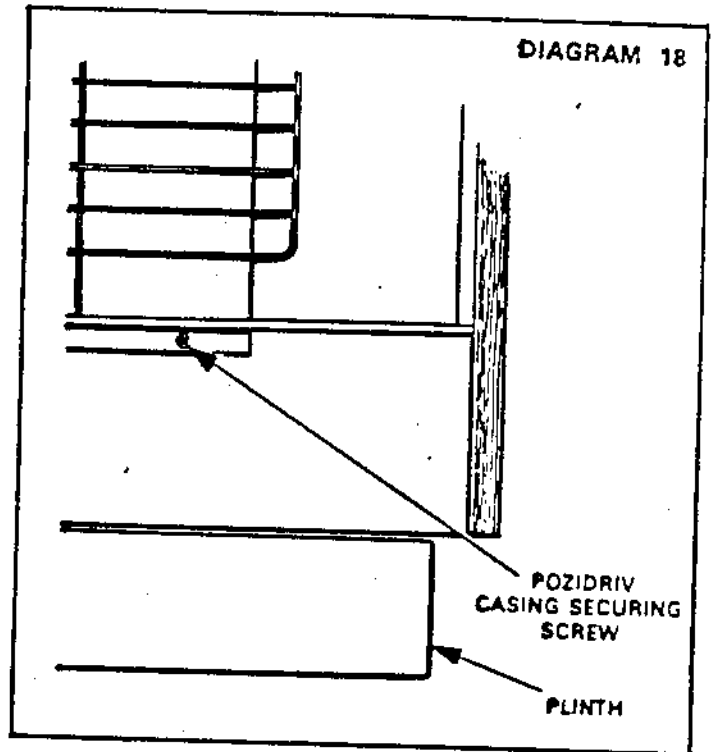

DIAGRAM 19

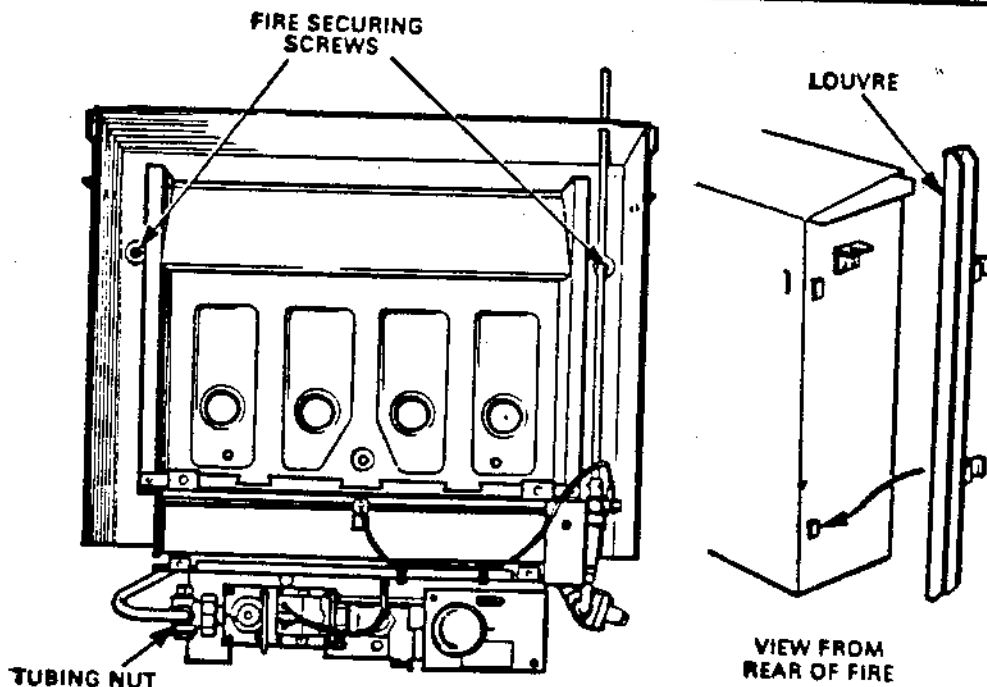
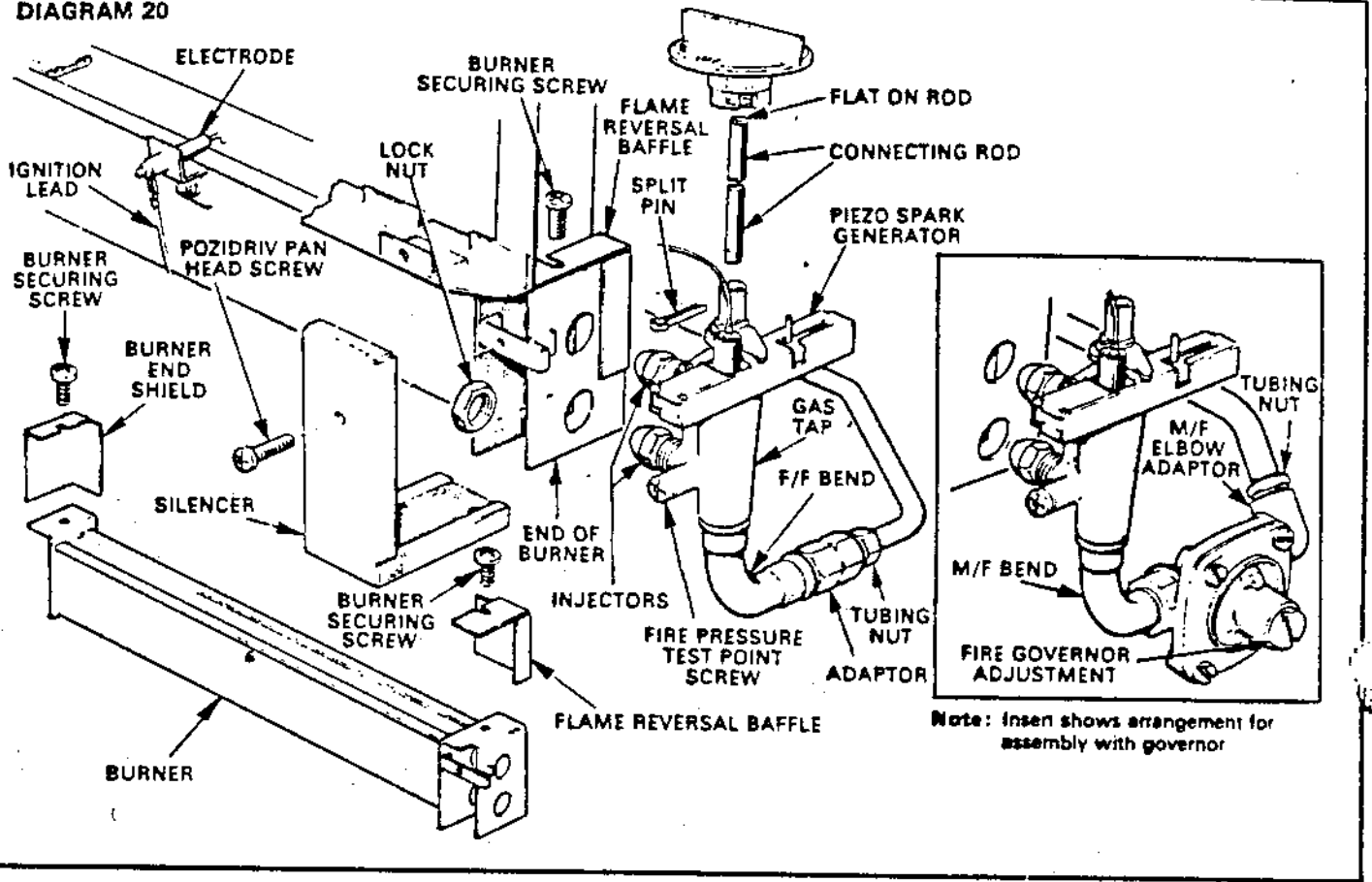

DIAGRAM 20



STAGE 8

INITIAL LIGHTING AND ADJUSTMENT OF FIRE

Set all controls to the 'OFF' position.
 Fit the gas fire control knob temporarily to the connecting rod. Ensure the gas fire is turned off. The 'OFF' on the control knob should be facing the front of the fire. Remove the gas fire test point screw from the fire gas tap (see diagram 20), and fit the pressure gauge. Turn the gas service tap to the "Boiler and fire on" position (see diagram 8), ensuring that all other controls are set for heating and turn the boiler thermostat to 'MAX' to re-light the boiler burner. Light the fire by pushing in the fire control knob and turning fully anti-clockwise until the 'H' marking is facing the front of the fire (see diagram 21). The fire burner should now be alight. If the fire fails to light it may be due to air being present in the gas fire piping, which may require purging. Set the gas pressure to that indicated on page 2, by adjusting fire governor screw 'X' (see diagram 17), after removing cover screw.

NOTE.—On the GALAXIE 246 'N', the gas fire pressure is pre-set at the factory and can be checked only.
 The primary cones on the gas fire burner should be 20 mm. (¾ in.) to 25 mm. (1 in.) in height with a clean burner. Turn off the fire by turning the control knob fully clockwise depressing slightly to pass 'L' and remove the control knob. Turn the boiler thermostat to the 'OFF' position, remove the pressure gauge and replace the test point screw.
 Fit the gas fire radiants by offering the top upwards into the heat exchanger, before pushing backwards and lowering on to the support strip.

STAGE 9

CASING FITTING

Lower the gas fire casing on to the heat exchanger assembly, tilting the bottom forward slightly, so that the dowels in the brackets on the sides of the casing locate in the holes in the brackets on the sides of the fire rear panel. Ensure that the gas control tap connecting rod passes through the hole in the casing top. Secure the casing with the two Pozidriv screws, just below the bottom reflector strip (see diagram 18). Fit the fire control knob to the connecting rod.

NORMAL BOILER LIGHTING PROCEDURE

It is assumed that the assembly and initial commissioning have been completed in accordance with described procedure.

1. Turn on gas and electricity at the supply point outside the unit.
2. See that all other controls are set for heating. The clock, room thermostat and programmer, if fitted, will be situated away from the unit.
3. Turn thermostat knob 'C' to the 'OFF' position (see diagram 17).
4. Turn the boiler gas control knob 'A' until 'PILOT' is opposite the red arrow.
5. Push in knob 'A' as far as it will go, and hold it there.
6. Press and release ignition button 'B' until the pilot burner is lit, and keep knob 'A' pushed in for approx. 20 secs. Look underneath the fire casing above the gas control valve for a circular viewing aperture where the pilot flame should be visible.
7. If pilot fails to light or to remain alight, do not force knob 'A' from the 'OFF' position; wait three minutes, then repeat from stage 4.
8. Make sure that the burner pilot is alight and stable, and then turn gas control knob 'A' to the 'ON' position. Set the boiler thermostat to maximum. The main burner will light at once.

DIAGRAM 21

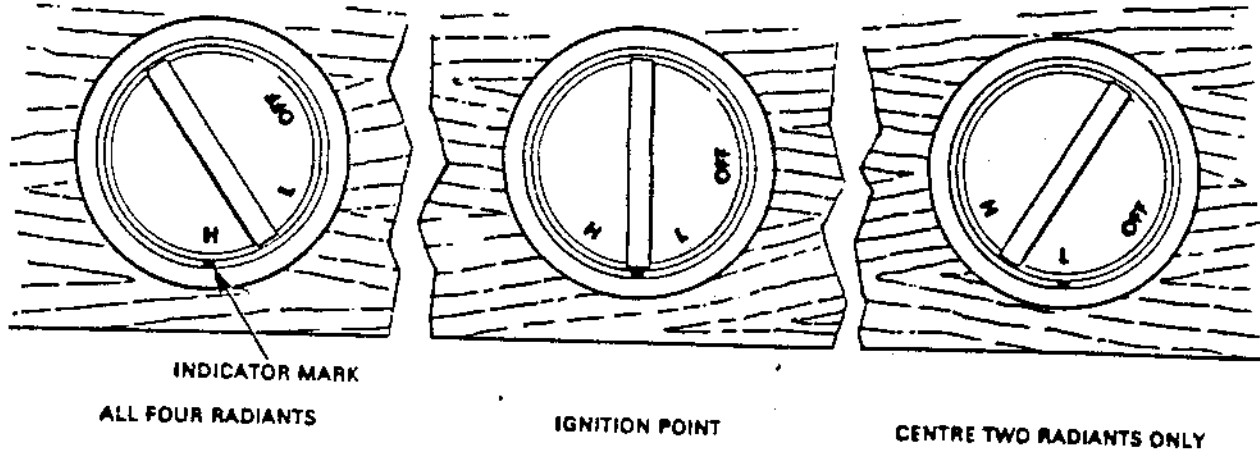

NORMAL FIRE LIGHTING PROCEDURE

The fire features spark ignition. This is actuated by pushing down the control knob and rotating it anti-clockwise. Ignition then occurs as the bar between 'H' and 'L' on the knob passes the indicator mark on the bezel on the top panel (see diagram 21).

To light the fire, push in and turn the control knob fully anti-clockwise to the 'H' position as indicated by the mark on the bezel on the top panel. All four radiants will light.

If the fire fails to light, turn the knob to the 'OFF' position and repeat the above lighting sequence.

To adjust the heat from the fire after it has been lit turn the control knob clockwise to the 'L' position. The centre two radiants only will be alight (see diagram 21).

TO TURN OFF

Turn the gas tap knob fully clockwise, depressing slightly to pass 'L' position to reach 'OFF'.

TO EXTINGUISH THE BOILER BURNER

The burner may be extinguished and re-established in any of the following ways:

1. By turning gas control knob 'A' to the 'OFF' position. This results in complete shut-down of both main and pilot burners. Thermostat knob 'C' should be turned to the 'OFF' position to de-energise the gas control electric operator leaving the electric clock running, but not controlling. Follow the Users' Lighting Instructions to re-light when THREE MINUTES have elapsed.
2. By turning the gas control knob 'A' to the 'pilot' position. This shuts off the main burner only. Thermostat knob 'C' should be turned to the 'OFF' position, as above; electric clock running, but not controlling; pilot burner alight. Re-light by turning gas control knob 'A' to the 'ON' position, re-set thermostat knob 'C' to the required temperature.

3. By turning the thermostat knob 'C' to the 'OFF' position. This shuts off the main burner only, leaving the electric clock running, but not controlling, and the pilot burner alight. Re-light by turning thermostat knob 'C' to the required temperature.
4. By switching off the electricity supply. This cuts out all electrical controls and the main burner, leaving the pilot burner alight. Re-light by switching on the electricity supply. Re-set electric clock to correct time.

CONTROL CHECK-OUT

After the initial lighting and adjustments have been carried out, the following check-out procedure may be used to ensure the correct operation of the controls.

OPERATION OF THERMOSTAT

1. With the main burner alight, turn the thermostat knob to the 'OFF' position. Result — the main burner should shut off.
2. Turn thermostat knob to the original setting. Result — the main burner should re-light.

OPERATION OF FLAME FAILURE DEVICE

With the main burner alight, turn the gas control knob 'A' to the 'OFF' position. After one minute the flame failure device should have closed. (A click from the control valve will indicate its operation.) After the flame failure device has closed, it will be possible to re-set knob 'A' back to pilot position.

It should not be possible to re-light the appliance without following the sequence of the Users' Lighting Instructions detailed earlier.

SETTING OF FIRE

Having completed the boiler control check-out, re-light the boiler burner and set the control devices to maintain the boiler burner on whilst the fire burner is checked for ignition.

PLINTH FITTING

Engage the upper return flanges of the plinth in the channels in the casing and slide the plinth backward as far as it will go.

MAINTENANCE

Servicing must be carried out by a qualified gas service engineer and where appropriate a qualified electrician.

SERVICING IN GENERAL

1. Gas Control Valve

The servicing of this control should only be undertaken by an engineer conversant in every respect with the equipment. Thermocouple union 'K' should be tightened only a quarter turn beyond finger tight to give good electrical continuity. Do not tighten further or damage may result.

2. Boiler Flueways

Regular cleaning of the boiler flue passages is necessary for efficient operation. Thorough cleaning should take place annually, preferably at the end of the heating season. The following directions should be followed to ensure correct servicing procedure.

- a. Isolate the appliance from the electricity supply. Ensure the gas fire control knob is turned to the 'OFF' position, then remove the control knob by pulling it vertically off the spindle. Unscrew the two lower fire casing securing screws, positioned just below the bottom reflector strip (see diagram 18). Pull the bottom of the casing forward slightly and raise the casing approximately 13 mm. ($\frac{1}{2}$ in.), easing the bottom forward and lifting vertically to clear the spindle.
- b. Remove the plinth by withdrawing it forwards.
- c. Turn the gas service tap 'O' to the 'OFF' position (see diagram 8). Remove the four Pozidriv pan head screws securing the inclined upper casing protection plate to the sides of the rear panel, and remove the protection plate.
- d. Remove the two side louvres from the slotted locations in the rear panel (see diagram 19).
- e. Unscrew the tubing nut securing the gas fire supply pipe and disconnect pipe from gas service tap. Remove the two slotted hex. head screws and washers securing the fire assembly to the fire support channel (see diagram 19). The top of the fire assembly can now be tilted forward slightly at the top to clear the flue duct, and lifted vertically to disengage the dowel location at the base of the fire assembly.
- f. Release the thermostat capillary from its clip on the fire support plate (see diagram 17). This is only necessary when the thermostat phial is fitted into the left-hand side of the boiler. Remove the phial from its pocket.
- g. Remove the two M6 hex. hd. screws and M6 washers securing the front cover and combustion chamber extension to the boiler body and remove the cover assembly, taking care not to damage the seal to the boiler body. Disconnect the electrical connections to the gas valve and disconnect the spark ignition lead at the spark generator.
- h. Disconnect the union at the service tap and unscrew the two M6 hex. head screws holding the burner supply pipe securing strap to the control box support bracket. Remove the gas valve and burner assembly from the boiler base by lifting slightly and withdrawing forward over the top of the control box, taking care not to damage the pilot burner or spark electrode.
- i. Unscrew the two M6 brass hex. head screws securing the front half of the flue collector to the rear half and remove the complete assembly of fire support channel, fire flue duct and flue collector front. Do not damage the asbestos seal.

- j. Lift out the three flueway baffles and clean out the flueway passages from the top and bottom, using a suitable stiff brush. A sheet of paper placed in the boiler combustion chamber will help in collecting the dust.

NOTE.—When re-fitting the thermostat phial ensure that it is inserted fully into its pocket and retained with the fix provided. If the phial pocket is fitted on the left-hand side of the boiler secure the capillary in the clip as shown in diagram 17.

3. Boiler Burner

With the boiler burner and gas valve assembly removed as under "Boiler Flueways" above, clean all accumulated lint and dust from around the burner, pilot burner, lint arrester and controls. Use a vacuum cleaner to avoid brushing the dust, etc., into the holes on the burner top. Remove the lint arrester from the burner assembly by unscrewing the retaining screw and clamping plate, (see diagram 23) and sliding the lint arrester forward from the burner. Thoroughly clean the lint arrester and around the injector. Replace the lint arrester by sliding on to the burner and secure with the clamping plate and screw.

4. Fire Burner

Clean all accumulated lint and dust from the fire burner using a vacuum cleaner. Also clean around the fire chassis.

5. Duplex Gas Tap

The gas tap may be serviced in situ after removing the plinth and casing as described under "Boiler flueways".

- a. Remove the split pin securing the connecting rod to the gas tap, noting the position of the flat at the top of the rod.
- b. Disconnect the ignition lead at the spark generator.
- c. With the tap in the 'OFF' position, remove the two screws and washers securing the niting plate, lift off the niting plate and remove the spring (see diagram 22).
- d. Remove the plug, clean and lightly re-grease.
- e. To re-assemble, insert the plug with the holes in the plug to the rear of the fire.
- f. Refit the spring and with the spindle in the 'OFF' position, replace the niting plate and secure with the two screws. Ensure that the spindle engages with the slots on the plug.
- g. Re-fit the connecting rod and split pin, making sure that the flat on the connecting rod is facing left. Re-fit the casing and control knob.

REPLACEMENT OF PARTS

Before removing or replacing any parts, make sure that the appliance is isolated from the electricity supply and the gas supply is turned off at service tap (see diagram 8).

1. Gas Fire Ignition Electrode

With the gas fire casing removed as described in Maintenance Instructions 2, a, Boiler Flueways, the gas fire ignition electrode, complete with bracket, can be removed after disconnecting the lead at the fire electrode

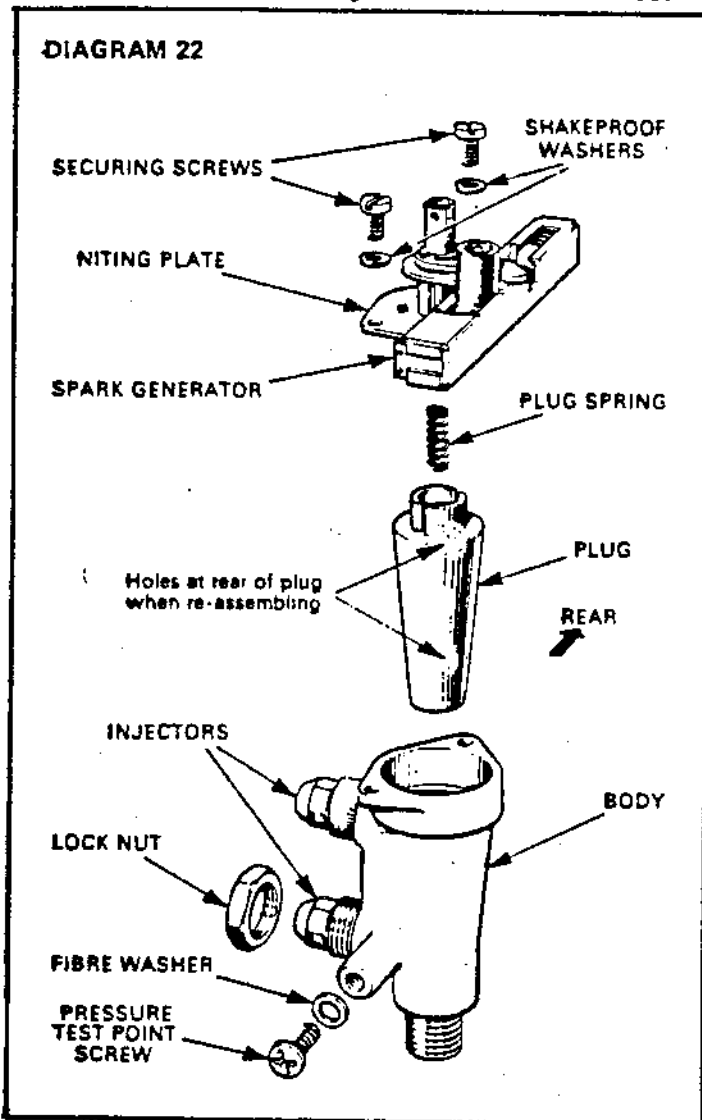

2. Fire Burner

First remove the plinth and outer casing as described in Maintenance Instructions, 2, Boiler Flueways a. and b. Disconnect the ignition lead at the fire electrode (see diagram 20). Unscrew the pan head screw securing the silencer and remove the silencer. Remove the split pin securing the control knob connecting rod to the gas tap spindle and withdraw the rod, noting the position of the flat at the top of the rod. Loosen the gas fire supply pipe tubing nut on the left hand side (see diagram 19), but do not remove. Unscrew the 19 mm. A/F locknut from the lower injector boss on the gas tap. Supporting the burner, unscrew the two Pozidriv pan head screws, one at each end of the burner at the side of the fire heat exchanger. When removing the two screws securing the burner, note that these screws also secure an end shield on the left and a flame reversal baffle on the right, (see diagram 20.) Ensure that these parts are fitted in the same positions as removed and immediately under the screw heads. Allow the gas tap and pipe assembly to rest on the electrical control box and remove the burner by moving to the left and forward, taking care not to damage the spark electrode. Re-fit in reverse order to that described. Re-fit the split pin making sure that the flat on the connecting rod is facing left. The two holes in the tap spindle for the split pin should be in line front to rear of the fire, indicating that the tap is in the 'OFF' position. Ensure that the tubing nut is re-tightened when the gas tap and burner are secured.

3. Fire Injectors

With the fire burner removed as previously described the injectors can be removed from the gas tap. When replacing the injectors a thread sealing compound must not be used, but care should be taken to ensure that the injectors are tightened sufficiently to provide a gas tight seal.

4. Duplex Gas Tap

To remove the gas tap proceed as in 2. above then unscrew the tubing nut and ease out the gas supply tube. Remove the gas tap and control assembly. When replacing make sure that the gas tap is in the 'OFF' position, i.e. when the two holes in the gas tap spindle for the split pin are in line front to rear of the fire.

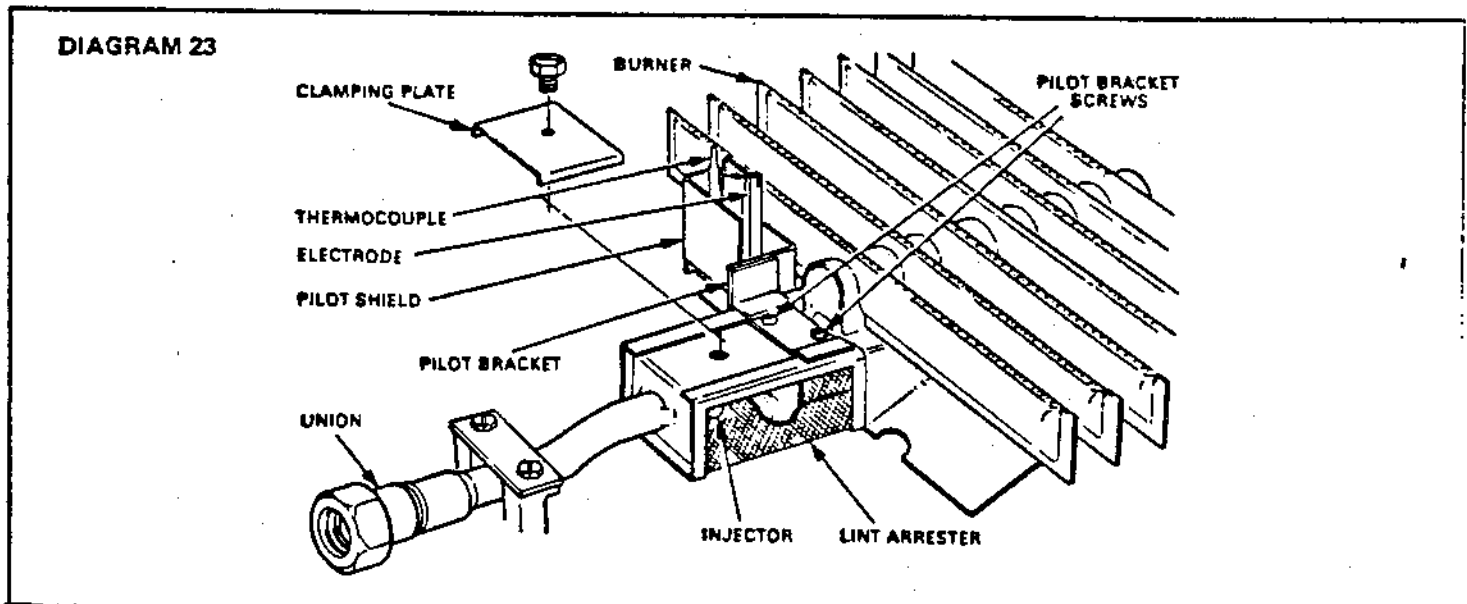

5. Gas Valve

First remove the gas fire as described in Maintenance Instructions under 2. Boiler Flueways, paragraphs a. to e. Make sure the gas service tap is in the 'OFF' position (see diagram 8). Disconnect the pilot supply pipe union and ease out connection. Disconnect thermocouple union 'K'. Disconnect the electrical wiring to the gas valve. Unscrew and disconnect the union at service tap 'Q', and the union elbow at the right hand side of the gas valve. The valve can now be removed and replaced. Re-fit the service tap and union elbow fittings to the replacement valve. Remove the pressure test nipple elbow from the original valve and re-fit in a similar position on the replacement valve. When re-assembling ensure that all joints are re-made gas tight, and that thermocouple union 'K' is not tightened more than one quarter turn beyond finger tight. It will be found necessary to purge the system of air after this operation, and re-lighting should be carried out in accordance with the initial lighting procedure as detailed on page 12.

6. Thermocouple

First remove the plinth, casing, fire heat exchanger assembly and combustion chamber front cover assembly as described in Maintenance Instructions (2. Boiler Flueways - paragraph a-h).

Remove the screw securing the pilot shield, (see diagram 23) and the clip securing the thermocouple to the pilot burner. Unscrew the thermocouple union 'K' on the gas valve, and remove the thermocouple completely. Replace taking care not to tighten thermocouple union 'K' more than a quarter turn beyond finger tight.

7. Boiler Burner

First remove the plinth, casing, fire heat exchanger assembly and combustion chamber front cover assembly as described in Maintenance Instructions (2. Boiler Flueways - paragraphs a-h).

Remove the two screws securing the pilot bracket and unscrew the union nut at the gas inlet to the burner, (see diagram 23). The burner will then be free. Transfer the union connection from the old burner to the replacement, using a little sealant on the threads.

CARE MUST BE TAKEN WHEN REMOVING AND REPLACING BURNER.

8. Boiler electrode

First remove the plinth, casing, fire heat exchanger assembly and combustion chamber front cover assembly as described in Maintenance Instructions (2. Boiler Flueways - paragraphs a-h).

With the boiler burner and gas control assembly removed remove the screw securing the pilot shield, (see diagram 23). Unscrew the pilot tube union at the gas valve, remove the two Pozidriv Taptite screws securing the pilot bracket to the burner and unscrew the hex. nut from the stud securing the electrode to the pilot bracket. Pull the ignition lead from the tag connection on the electrode. When re-fitting the electrode, replace the nut on the lower stud and ensure that the spark gap is as shown in diagram 7.

9. Boiler pilot burner

First remove the plinth, casing, fire heat exchanger assembly and combustion chamber front cover assembly as described in Maintenance Instructions (2. Boiler Flueways - paragraphs a-h).

Remove the pilot shield, gas valve pilot union and pilot

bracket screws as in 8. Boiler electrode, remove the clip securing the thermocouple to the pilot burner and withdraw the thermocouple. Unscrew the hex. nut from the stud securing the electrode to the pilot bracket and the cheese head screw, washer and nut securing the pilot burner. Disconnect the pilot tube at the base of the pilot burner by using two spanners, one on the union and the other on the hexagon immediately above the union nut and thread.

When re-fitting, secure electrode by the lower stud and ensure that the spark gap is as shown in diagram 7.

10. Boiler injector

First remove the plinth, casing, fire heat exchanger assembly and combustion chamber front cover assembly as described in Maintenance Instructions (2. Boiler Flueways - paragraphs a-h).

Remove the lint arrester from the burner assembly by unscrewing the retaining screw and removing the clamping plate, (see diagram 23). Slide the lint arrester forward from the burner. Unscrew the injector and replace using a little sealing compound on the threads.

11. Electrical Control Box

Remove the plinth, casing and the fire heat exchanger and rear panel assembly as described in Maintenance Instructions. Pull the thermostat control knob forwards off its spindle and disconnect the spark ignition lead at the spark generator. Remove the two Pozidriv pan head screws and shakeproof washers securing the cover to the control box body and remove the cover. Disconnect all external leads at the terminal strip, slackening off the screw securing the mains cable clip to enable the mains cable to be withdrawn.

Release the thermostat capillary from its clip on the fire support plate (see diagram 17). This is only necessary when the thermostat phial is fitted into the left-hand side of the boiler. Remove the phial from its pocket. The control box is secured to a bracket with two M5 hex. head screws and hex. nuts. Remove these and the control box may then be withdrawn. Replace in the reverse order. For details of the wiring see relevant wiring diagrams under "Installation".

Note.—When re-fitting the thermostat phial ensure that it is inserted *fully* into its pocket and retained with the fix provided. If the phial pocket is fitted on the left-hand side of the boiler secure the capillary in the clip as shown in diagram 17.

12. Boiler piezo generator

Remove the plinth, casing and the fire heat exchanger and rear panel assembly as described in Maintenance Instructions, 2: Boiler Flueways. Remove the boiler thermostat knob and control box cover as described in 11. Electrical Control Box, above. The generator can then be removed as necessary. Replace in the reverse order.

13. Fire piezo generator

Remove the plinth and casing as described in Maintenance Instructions, 2: Boiler Flueways, and remove the piezo generator and niting plate assembly as described in Maintenance Instructions, 5: Duplex Gas Tap, (a), (b) and (c). Replace in reverse order as described in 5: Duplex Gas Tap, (e) to (g).

NOTE: Where a replacement generator is required, it is important to note whether the gas tap is a Concentric (brass body) or Harper Wyman (aluminium body) assembly.

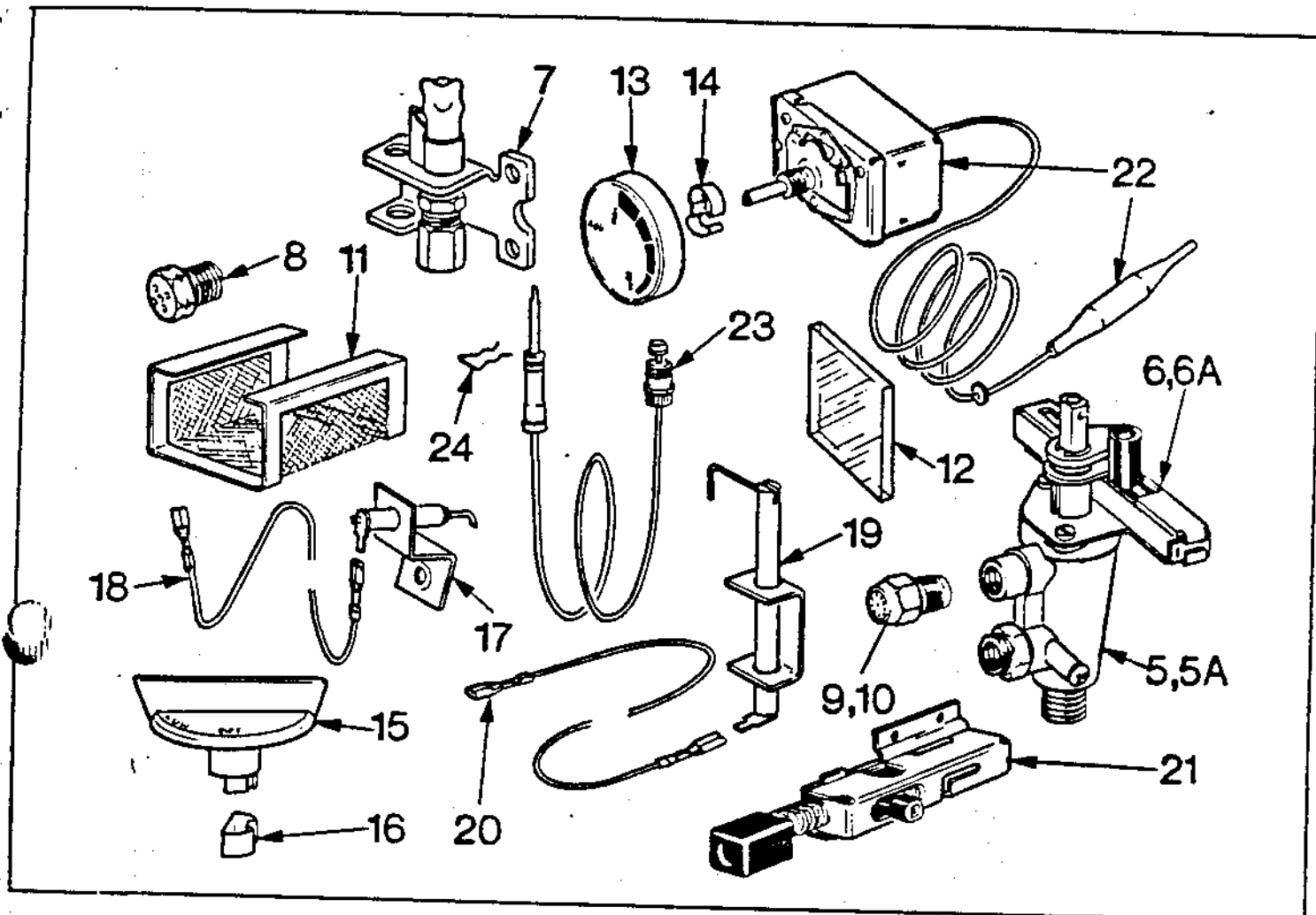

REPLACEMENT PARTS

Item No.	G.C. Part No.	Description	Maker's Part No.
5	387 696	Gas tap - fire (brass body) c/w Piezo generator, Concentric JC/A/385	K7344
5A	384 765	Gas tap - fire (aluminium body) c/w Piezo generator, Harper Wyman 1A-2610-06	K7344
6	388 062	Piezo generator - fire, Concentric JC/SA/1260 (for Item 5 only)	K8059
6A	393 776	Piezo generator - fire, Harper Wyman 1A-2619-06 (for Item 5A only)	K9265
7	391 535	Pilot burner c/w straight adaptor, Maclaren 26T0166 TL016	K8356
8	384 673	Injector - boiler (NG) Furigas 015.015.000	K9207
9	398 321	Injector - fire (N.G. Cat 2TN); Bray Cat. 16 No.300	K6267
10	398 455	Injector - fire (N.G. Cat 1N), Bray Cat. 28 No.220	K7348
11	384 669	Lint arrester, Furigas 018.014.000	K9210
12	351 661	Sight glass	K5226
13	351 912	Control knob - boiler thermostat	M7969
14	396 216	Clip - control knob, Lewis Spring LS/402/17	K4158
15	152 443	Control knob - fire	K6946
16	152 554	Clip - control knob, KC 1/4/0148/BD35	K8548
17	387 982	Electrode - fire, Kigass E5446	K7343
18	387 983	Ignition lead - fire, Kigass E5451	K7707
19	393 713	Electrode - boiler, Kigass E6645	K9206
20	135 945	Ignition lead - boiler	K9218
21	397 907	Piezo generator - boiler, Kigass D5037	K6587
21	393 563	Piezo generator - boiler, Vernitron Variant 66108	K6587
22	382 312	Thermostat - boiler, Ranco G1-11683	K7958
23	390 929	Thermocouple, Maclaren 2500M-24	K4860
24	390 983	Clip - thermocouple	K3580

Alternatives

Alternatives

Because of our constant endeavour for improvement, details may vary slightly from those given in this booklet.

Replacement Parts continued overleaf

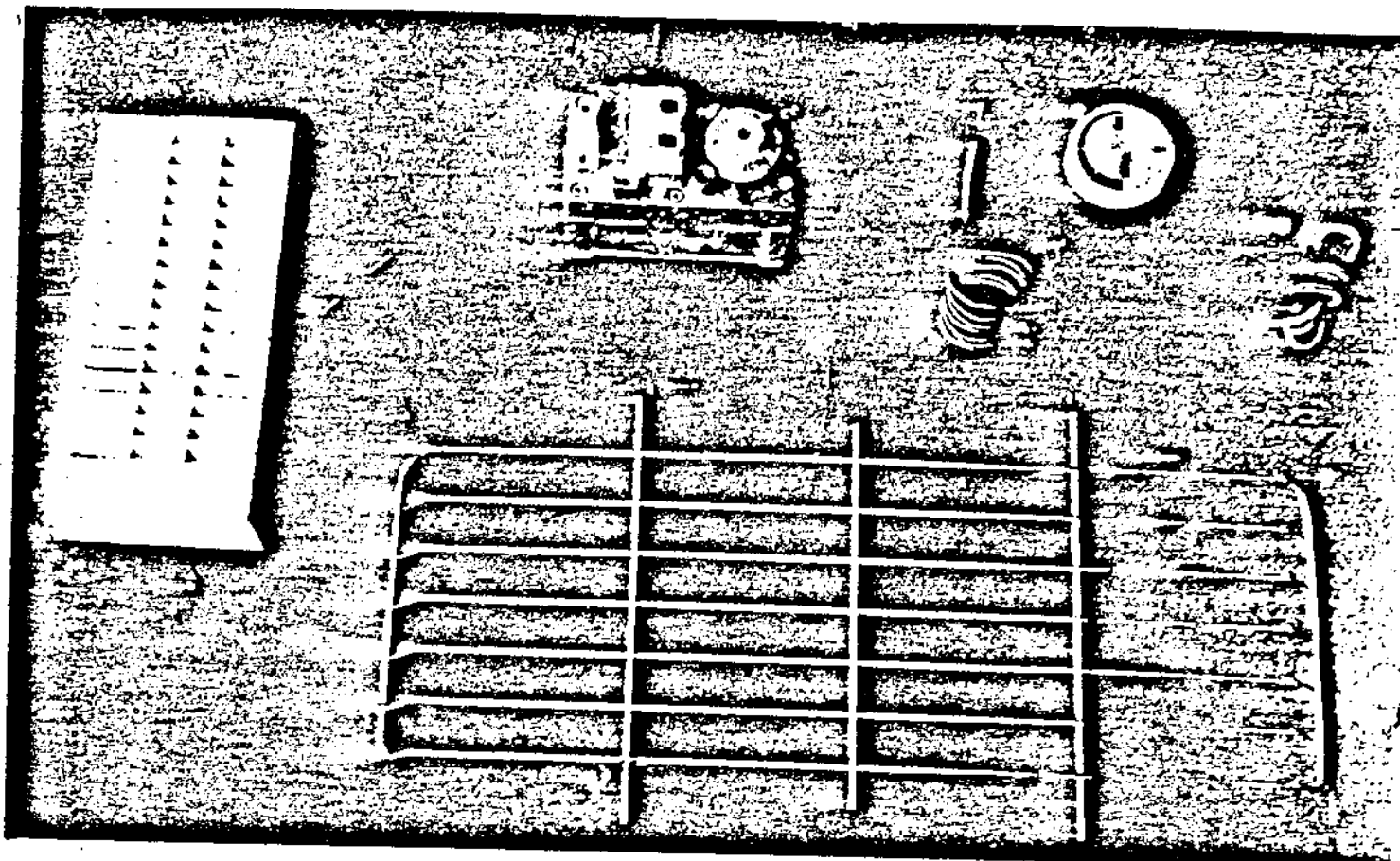

REPLACEMENTS PARTS—continued

Item No.	G.C. Part No.	Description	Maker's Part No.
1	152 405	Dress guard	
2	152 442	Radiant	K6223
3	191 199	Electrical control box	K6936
4	392 767	½in. BSP Midgitrol gas valve, Maclaren UK 48RBB05	M9057 K9049

MANUFACTURED BY Glow-worm Limited, Nottingham Road, Belper, Derby DE5 1JT

Tel. Belper 4141 Telex 37586 Gloworm Belper Service Engineer Enquiries only Belper 6516

DOMESTIC BOILER AND HEATING APPLIANCE MANUFACTURERS

