



17562.0007.0

Spare parts list series 100

Edition 12/2002



Savio[®]
caldaie

Spare parts list series 100

1 REPLACEMENT PARTS CATALOGUE

This catalogue includes all the replacement parts required for the maintenance and service of SAVIO boilers. This edition of the catalogue supersedes all previous editions.

2 MODELS AND SPECIFICATIONS

SAVIO produces a number of boilers to satisfy a wide range of user needs and installation requirements.

All SAVIO boilers are wall mounted, with instantaneous operation and modulating heat regulation; that is, the amount of heat from gas combustion is automatically varied according to the heat required by the heating system.

SAVIO boilers differ in four basic characteristics:

2.1 Maximum useful heating power during operation as a building heat source

Three models are available with different maximum useful heating power when used as a building heat source. Each of these models is identified by its own model number:

Models 120 (20 000 Kcal) and 124 (24 000 Kcal)

2.2 Mixed-type operation/operation as a building heat source only

Mixed-type boilers are used to heat water for use in a building heating system, and can also heat hot water for domestic use. This type of boiler alternates between the two operating modes, with the "domestic hot water" function taking precedence over the "building heat source" function. These boilers are identified by the letter "M" in their model number.

2.3 Type of gas lighting system

The gas in a boiler can be lit in two different ways:

a) By a pilot burner in the combustion chamber; this burner uses a continuously-operating flame to light the main burner.

b) The other lighting system used in SAVIO boilers is automatic electronic ignition. Models with electronic ignition are identified by the letter "E" in their model number, except models "MFS", which are not produced in versions using a pilot burner.

2.4 Fume exhaust method

The fumes in the combustion chamber can be exhausted in one of three different ways:

A – Natural drafting (by the atmosphere)

boilers using this system must be connected to an adequately-sized exhaust duct system (chimney), and use air from the installation area for combustion.

B – Forced exhaust from a sealed combustion chamber

boilers using this system are equipped with a fan which forces the fumes through an adequately-sized exhaust duct system; however, the combustion chamber is enclosed in a sealed chamber and is isolated from the installation area. boilers using this system are identified by the letter "MFS" in their model number, and do not use air from the installation area for combustion.

3 MODEL IDENTIFICATION CODE/SERIAL NUMBER

Every boiler produced by SAVIO carries its own model identification code/serial number.

It is important for the service centre to mention this number when contacting the factory (the number must be listed on guarantee claims and service reports; when making requests for technical information, etc.).

The following is a breakdown of the model identification code/serial number and its meaning (reading from left to right):

- A) The maximum useful heating power during operation as a building heat source (see 2.1).
- B) The type of boiler according to its functions (see 2.2, 2.3 and 2.4)
- C) The type of gas used by this boiler. The letter "M" is used for methane; the letter "G" is used for liquefied petroleum gas (LPG).
- D) The first four numbers are the actual serial number.
- E) The last four numbers indicate the month (first two numbers) and the year of construction.

These numbers are used in this catalogue to distinguish between versions of the same model with different modifications.

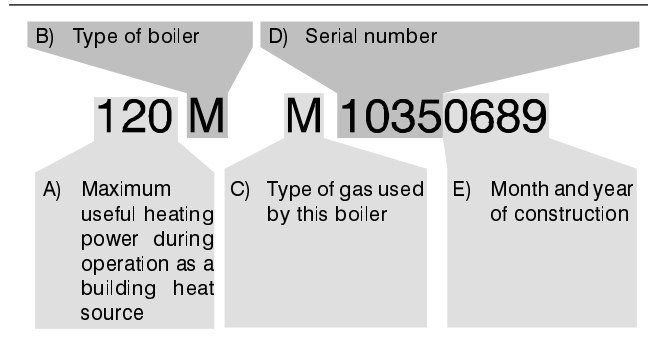

4 REPLACEMENT PARTS CODE

Each currently available replacement part is uniquely identified by its own replacement parts code. The replacement parts code consists of a table code and a position code.

4.1 Table code

The table code is a sequence of letters and numbers which uniquely and clearly identify each table. The table code can be found on the upper right of each table (see 4.3).

A validity chart for the table is located at the bottom of the table. This chart lists the models covered by the table.

	120ME			120MFS	
	124ME			124MFS	

4.2 Position Code

The position code is a number which is used to identify a particular object on the table.

To make identification easier, position codes for kits have a different format from position codes for individual parts.



A label can be found next to the position code. This label is used to provide additional information on the replacement part and makes identification of the part easier:

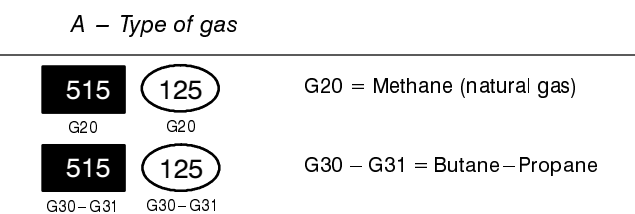

B – Gasket types and dimensions

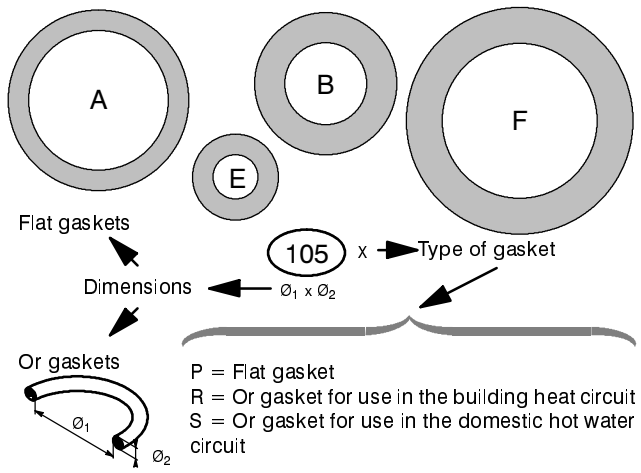

The dimensions of flat gaskets are indicated by the actual-size representation (A, B, C, D, E) in the figure above.

ATTENTION

If two or more of the same type of gasket have the same dimensions, the gaskets are identical (even though they have different replacement part codes).

515 120M	125 120M	For model 120M, only
515 M	125 M	For mixed-type models (M), only

4.3 Composition of the replacement part code

Each replacement part code includes a table identification code and a position code. A position code is only listed for replacement parts which are currently available.

The replacement part code consists of the table code (which can be found on the upper right of the table) plus the position code (in two formats: individual part or kit).

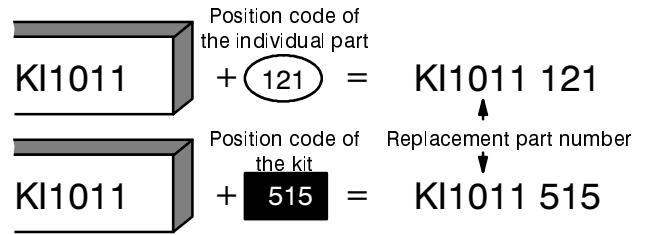

The components of a kit are enclosed in a broken line. A kit may contain other complete kits, or portions of other kits.

In some tables, a replacement part may be identified with an arrow and a complete replacement part code (table code + position code). This means that the part is available, but must be ordered with the code listed. Also, any explanatory notes must be read before ordering.

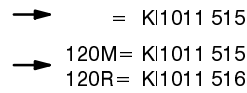

4.4 Using the replacement parts code

The replacement parts code must be included on all documents which are used in service reports, orders for replacement parts, guarantee claims, etc.

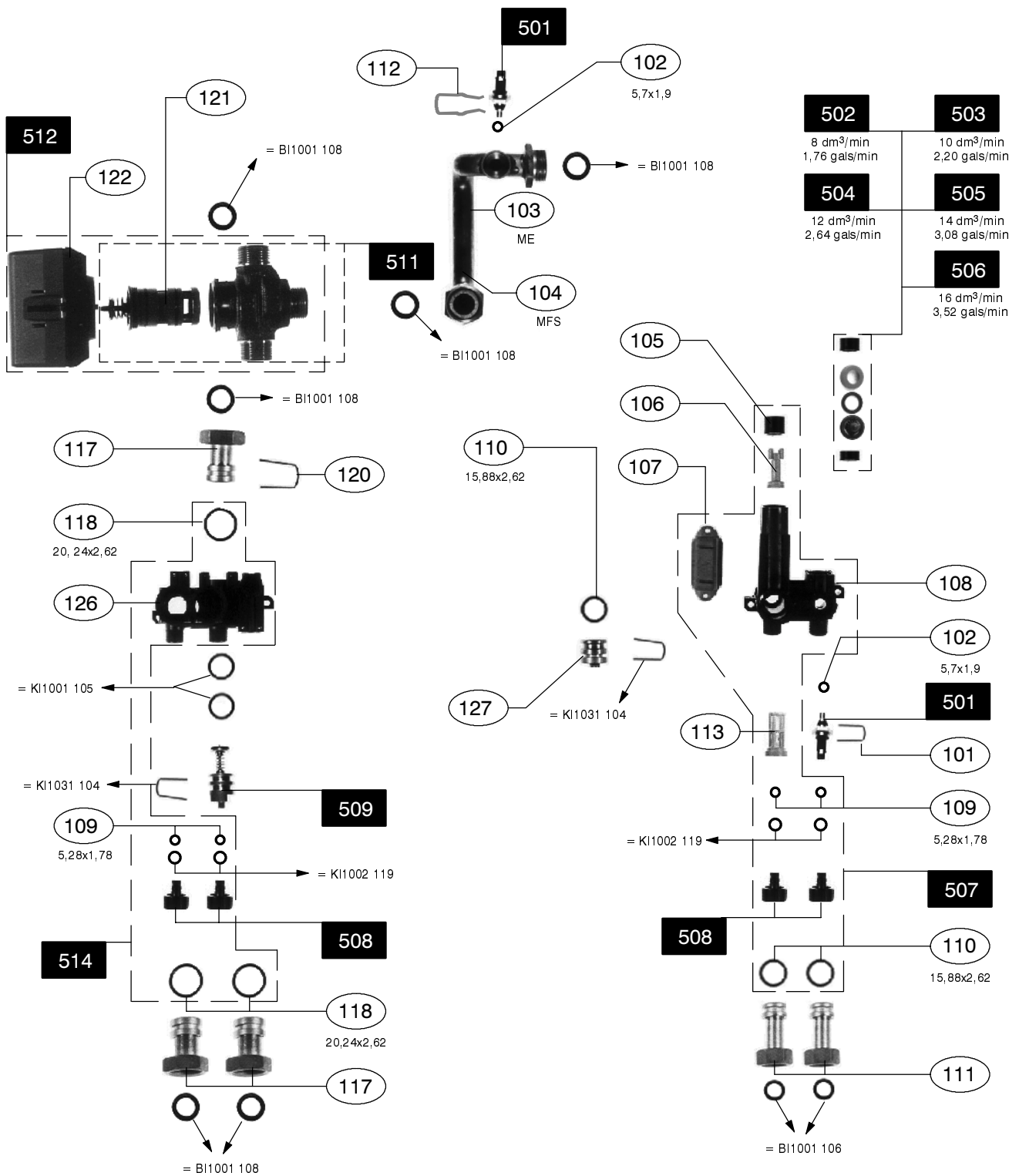

P = Flat packing
R = O-Ring packing

	120ME			120MFS					
	124ME			124MFS					



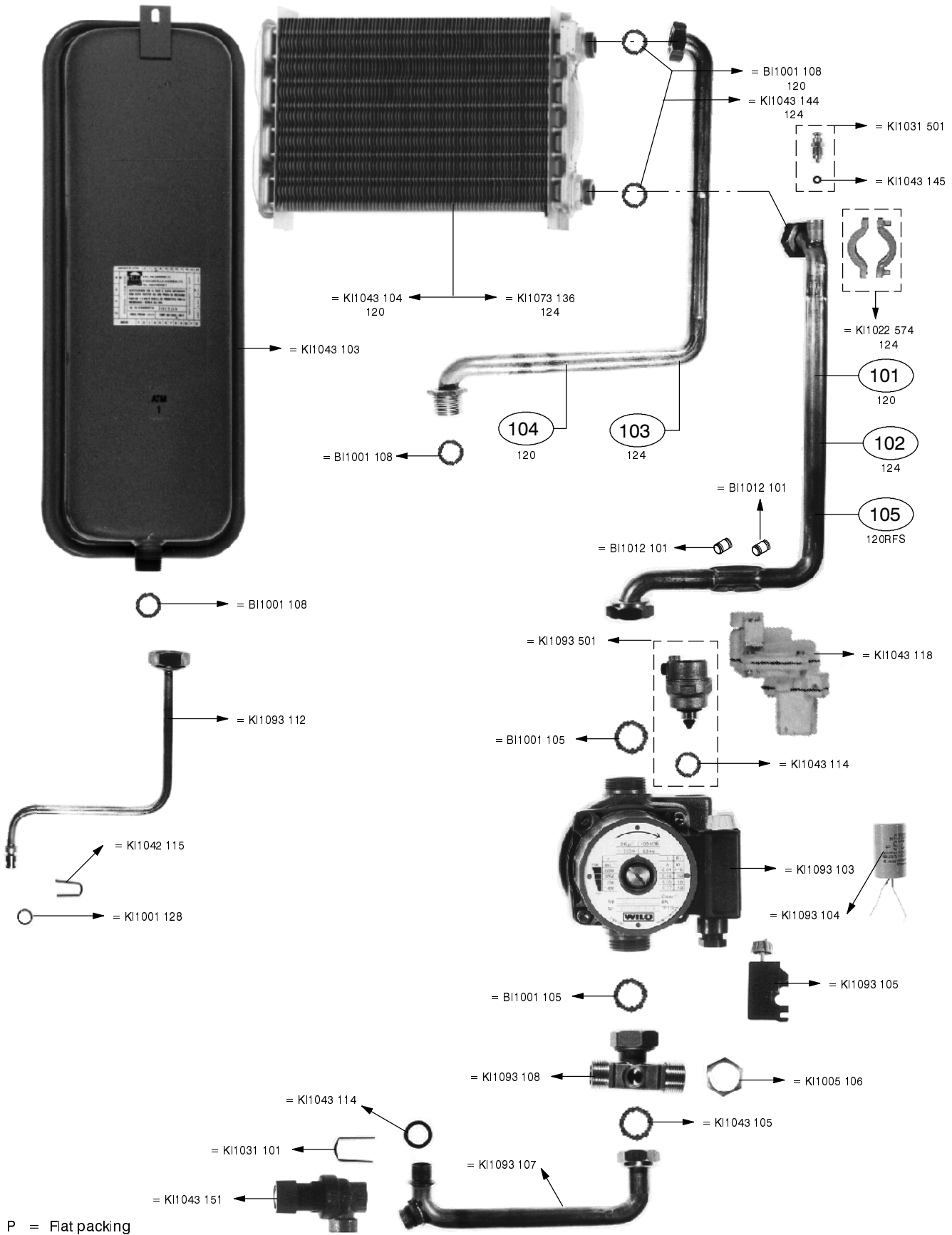

120MFS
124MFS

120RFS



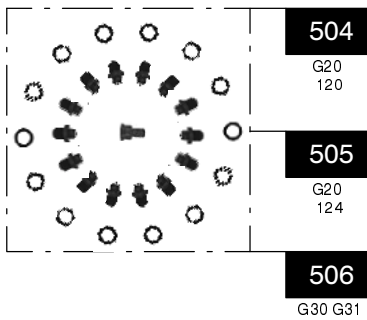
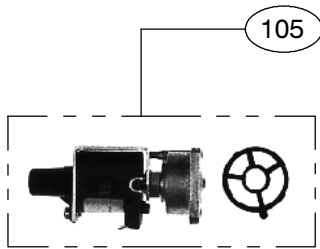
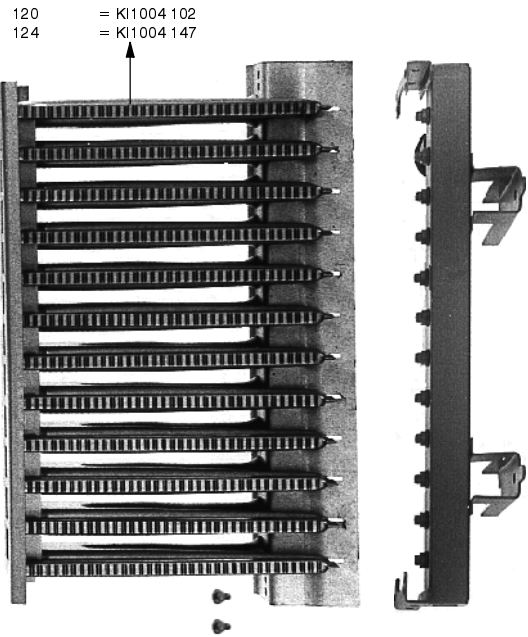
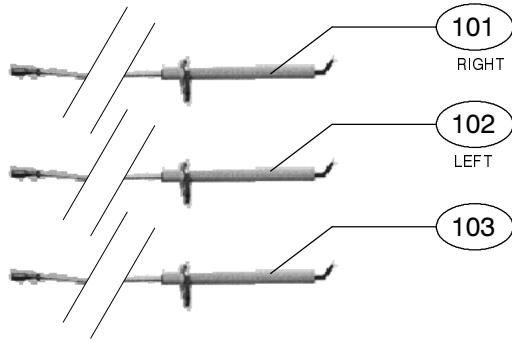

504

G20
120

505

G20
124

506

G30 G31

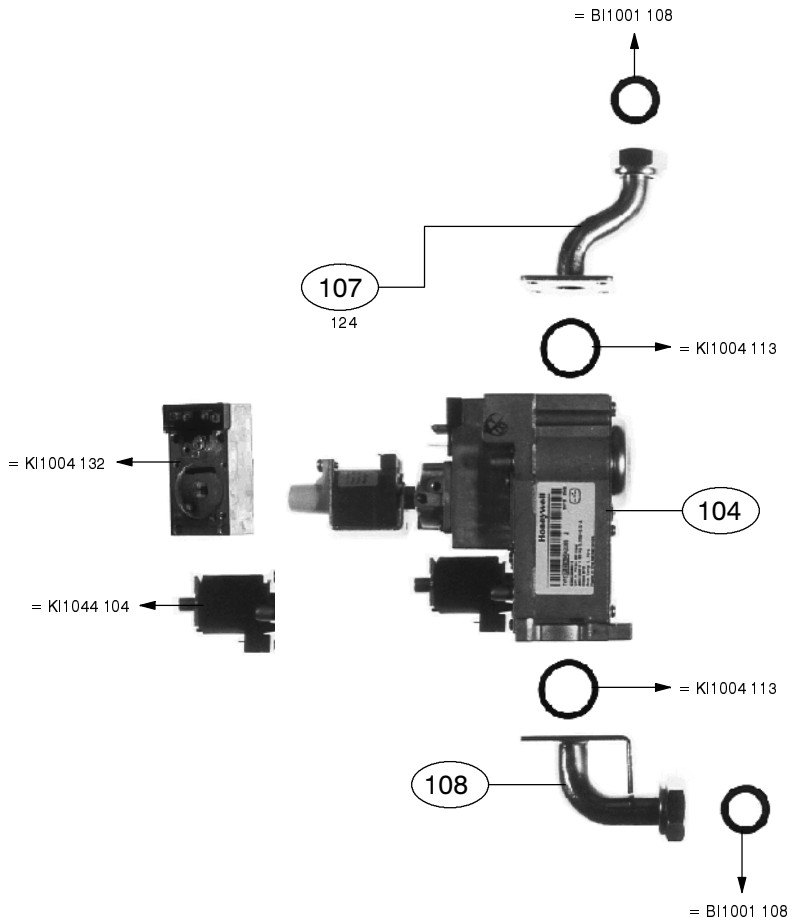

P = Flat packing
R = O-Ring packing

	120ME																		
	124ME																		



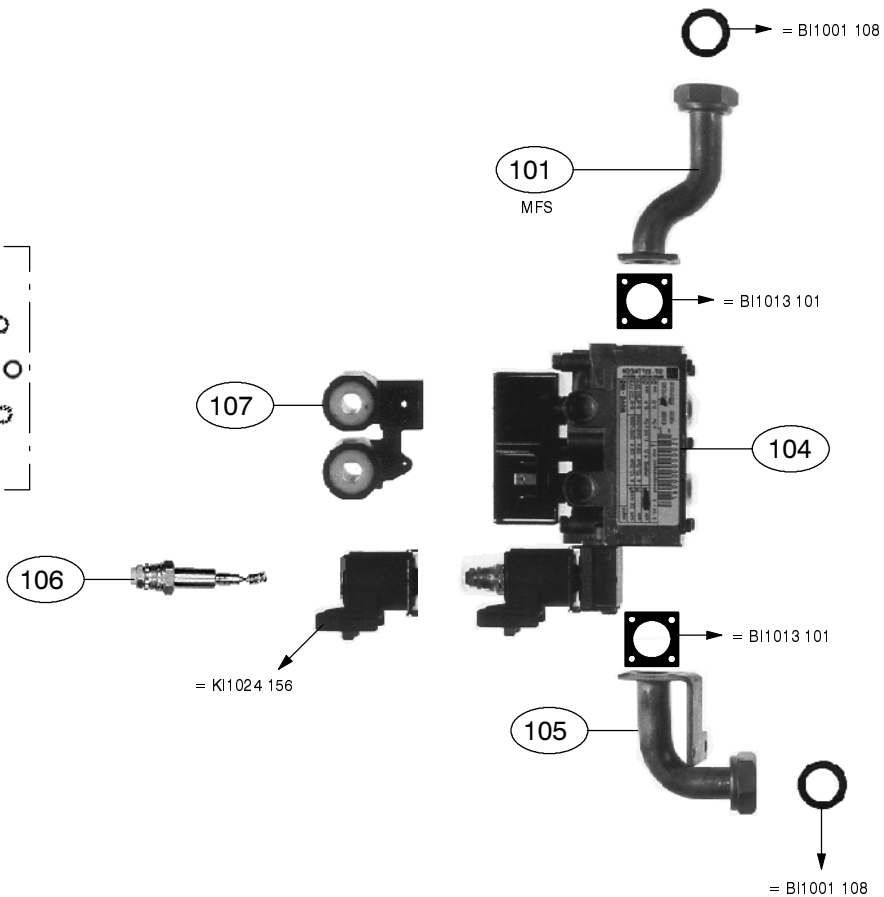
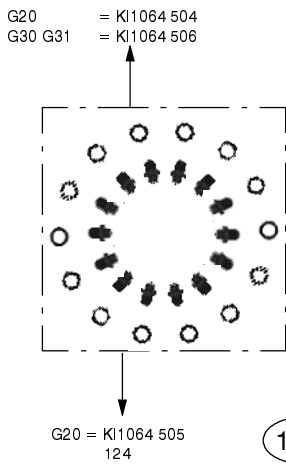
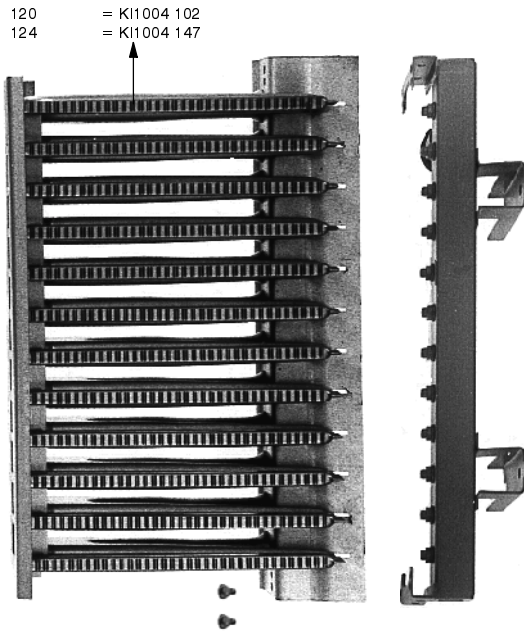
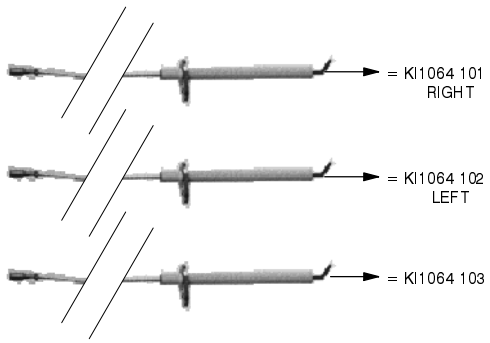

P = Flat packing
R = O-Ring packing

0699

				120MFS					120RFS
				124MFS					



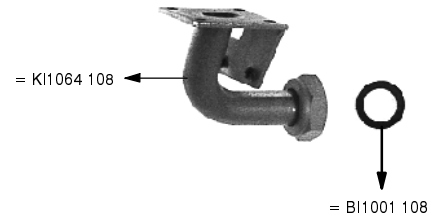
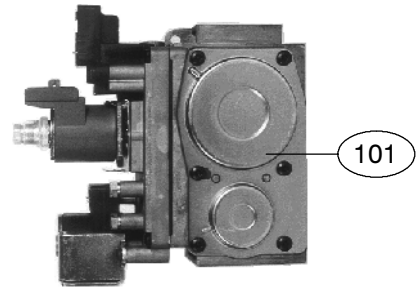
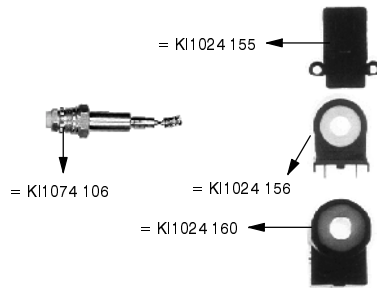
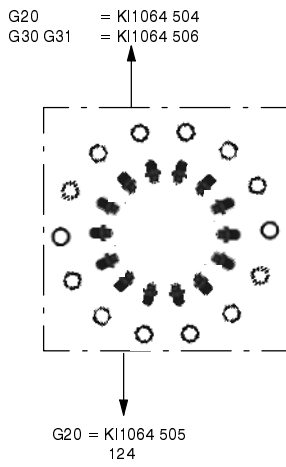
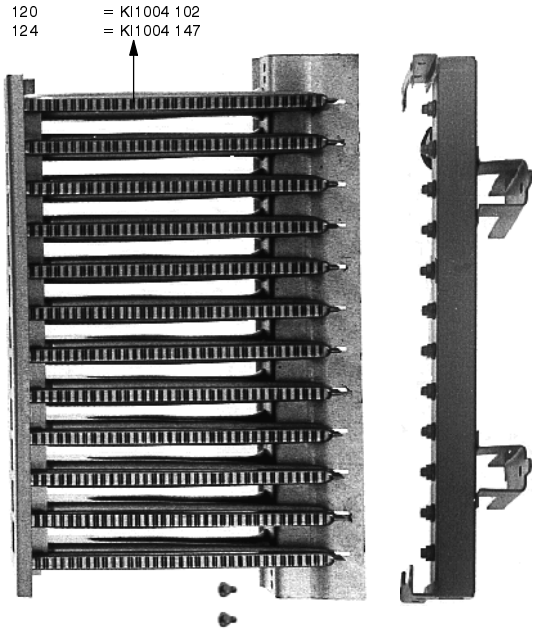
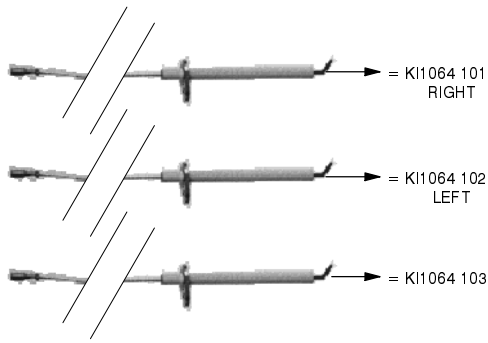

P = Flat packing
R = O-Ring packing

				120MFS					120RFS
				124MFS					



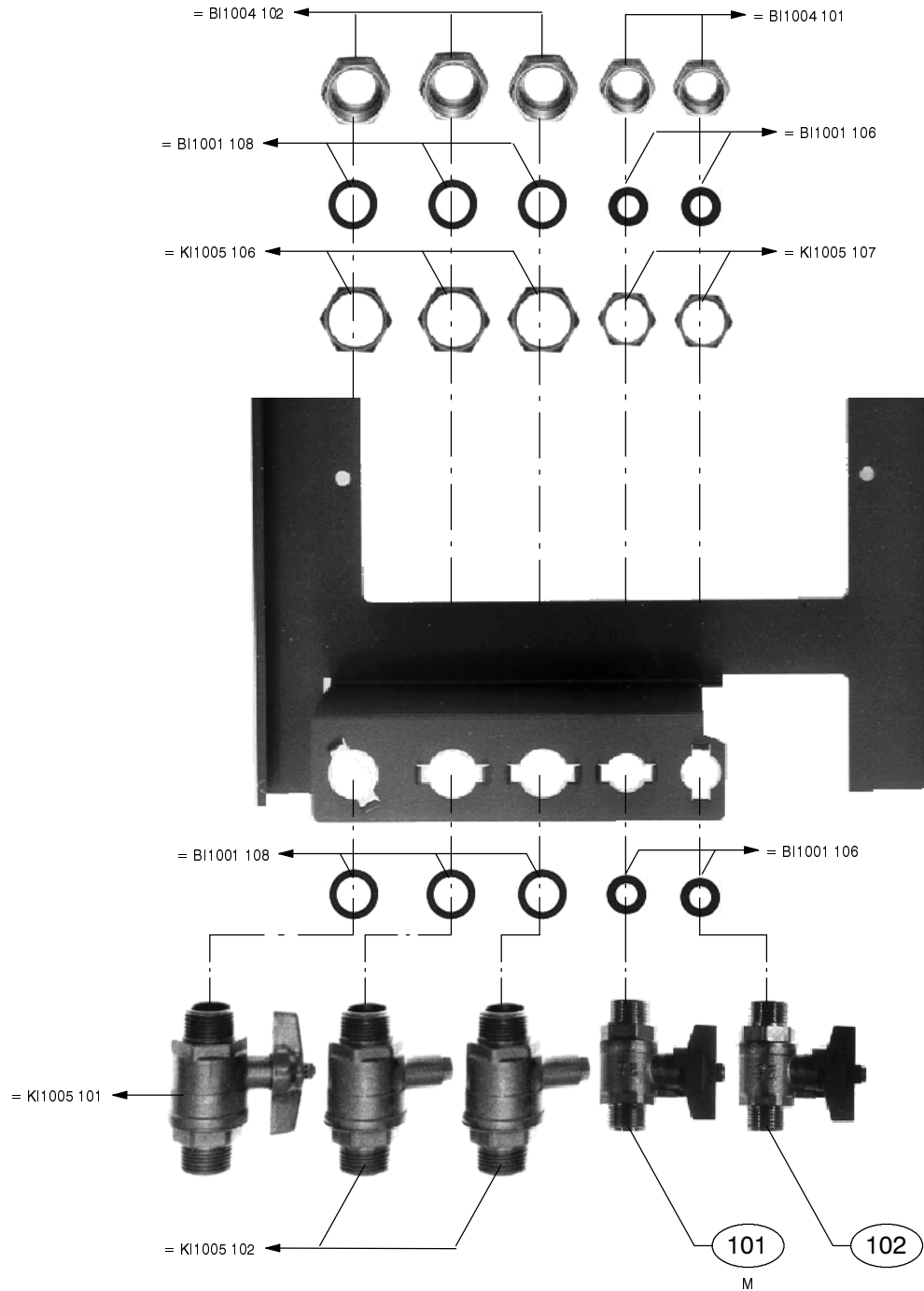

P = Flat packing
R = O-Ring packing

0798

	120ME			120MFS					120RFS
	124ME			124MFS					



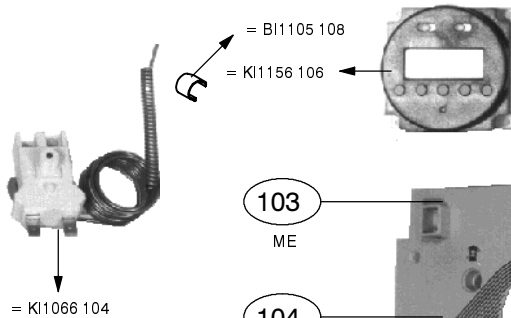
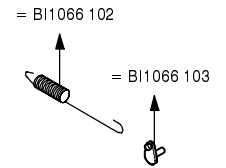
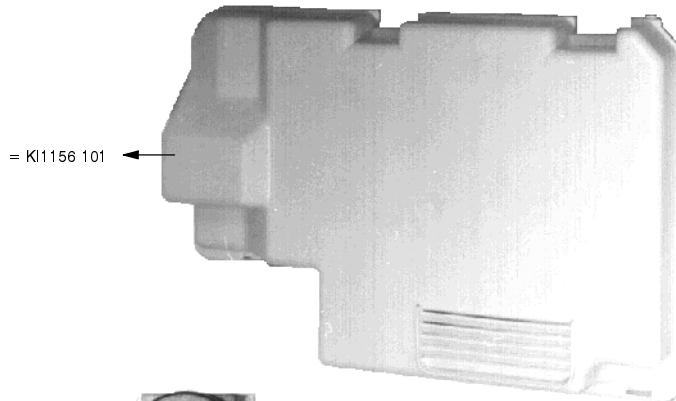
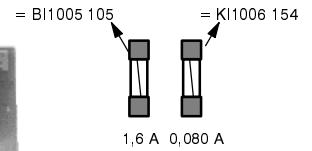
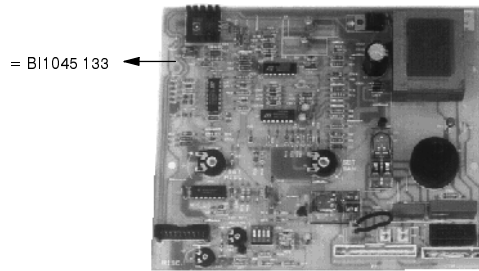
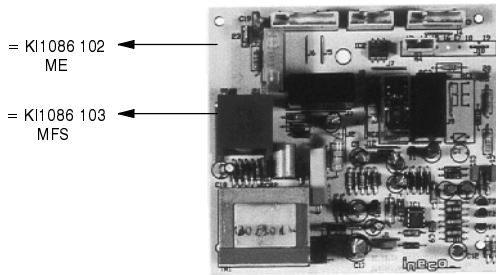
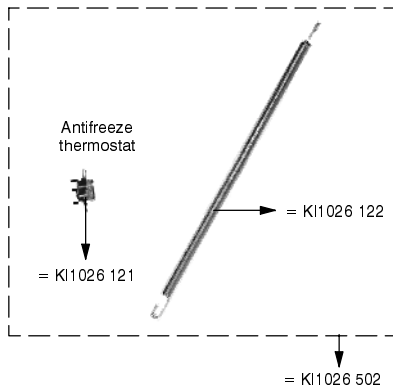

103
ME

104
MFS

106

107
RFS

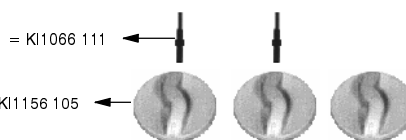
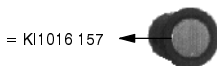
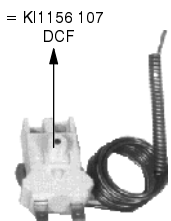

P = Flat packing
R = O-Ring packing

	120ME			120MFS				120RFS
	124ME			124MFS				



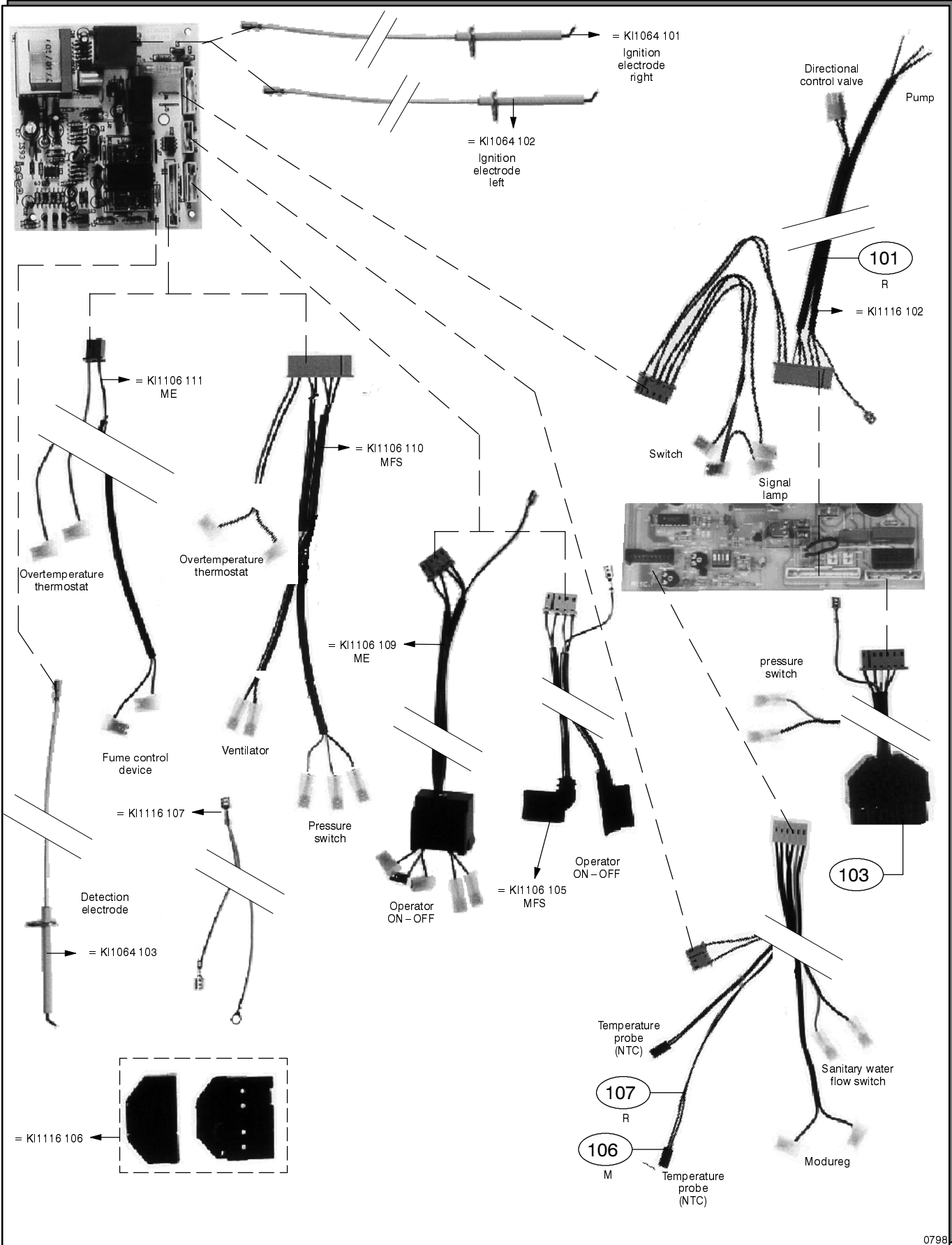

0798

	120ME		120MFS			120RFS
	124ME		124MFS			



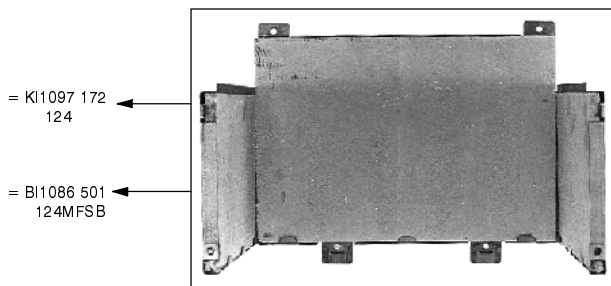
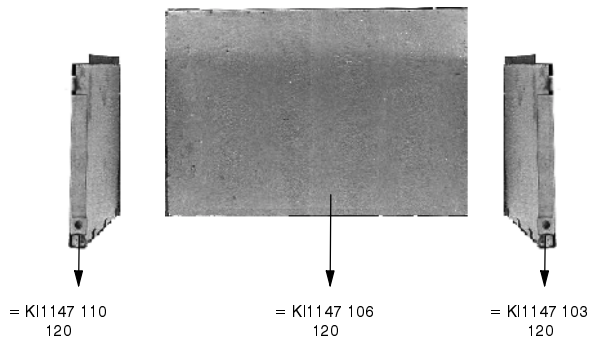
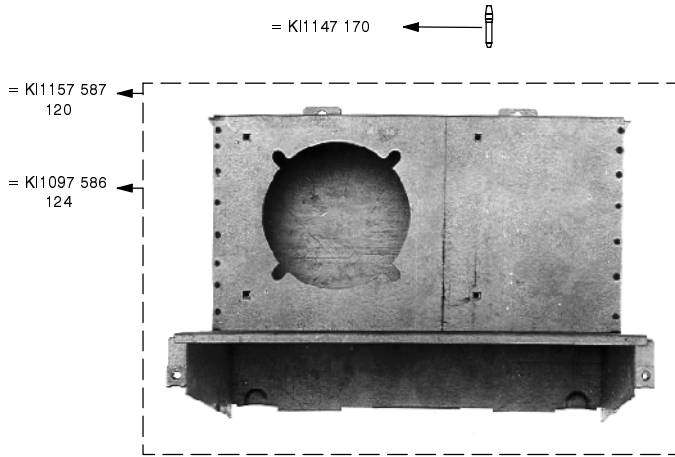

501

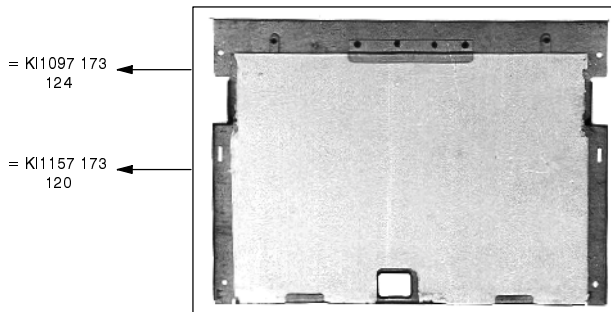
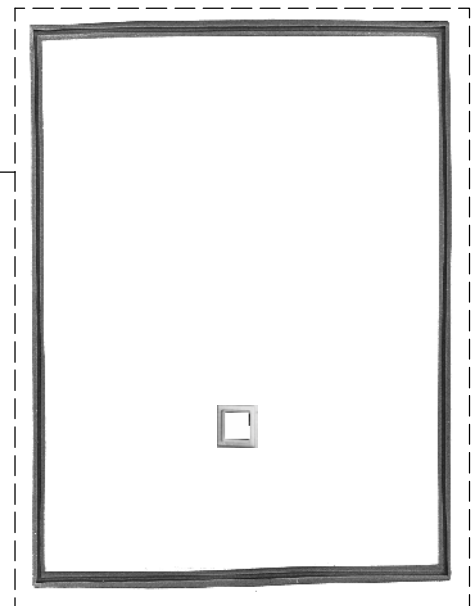

0700

				120MFS					120RFS
				124MFS					



= KI1147 586
120

= KI1127 587
124



= KI1097 172
124

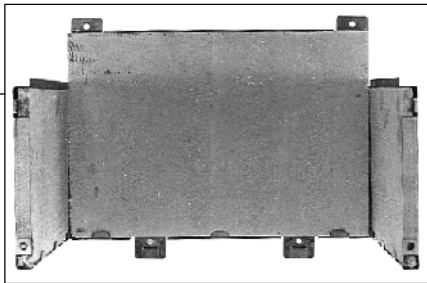

= KI1147 110
120



= KI1147 106
120

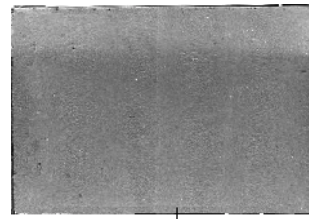

= KI1147 103
120



= KI1147 173
120

= KI1127 173
124

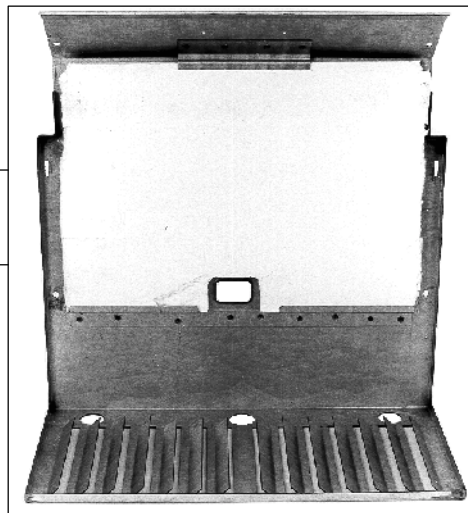

P = Flat packing
R = O-Ring packing

	120ME									
	124ME									



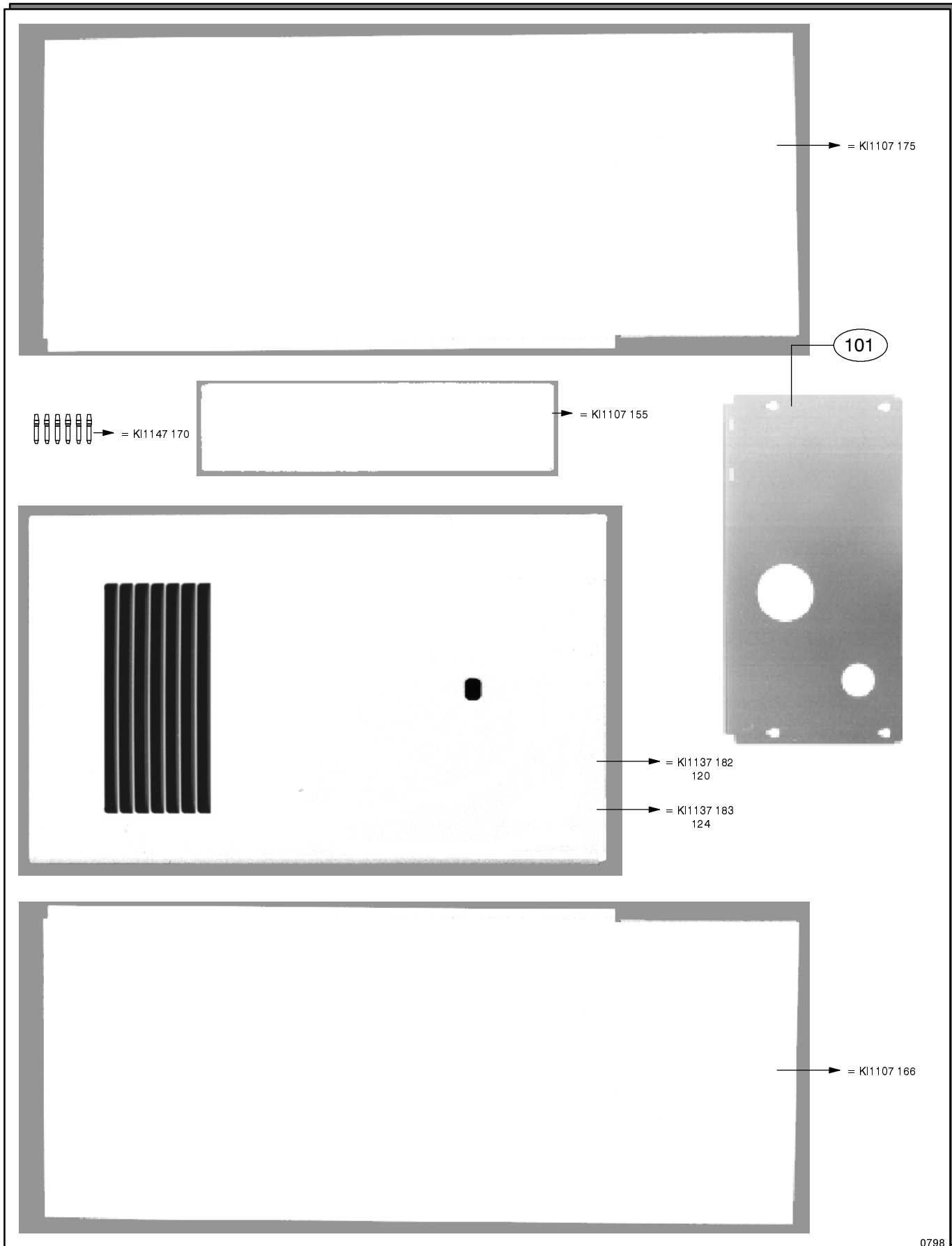

0798

	120ME																			
	124ME																			



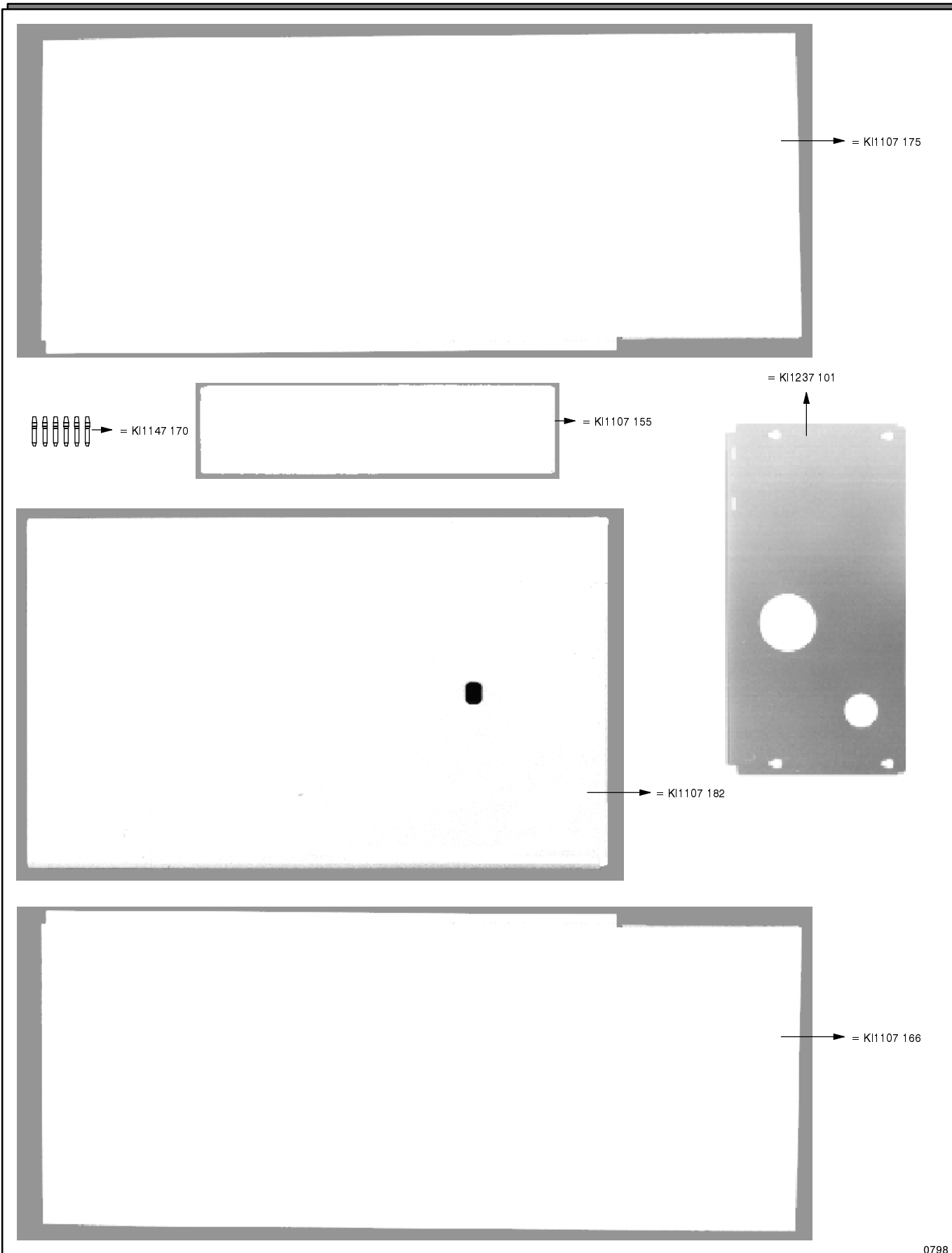

0798

				120MFS					120RFS
				124MFS					



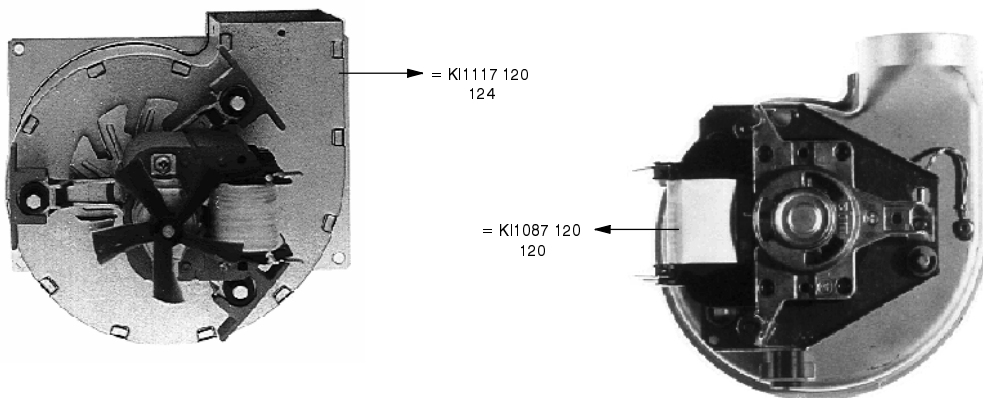
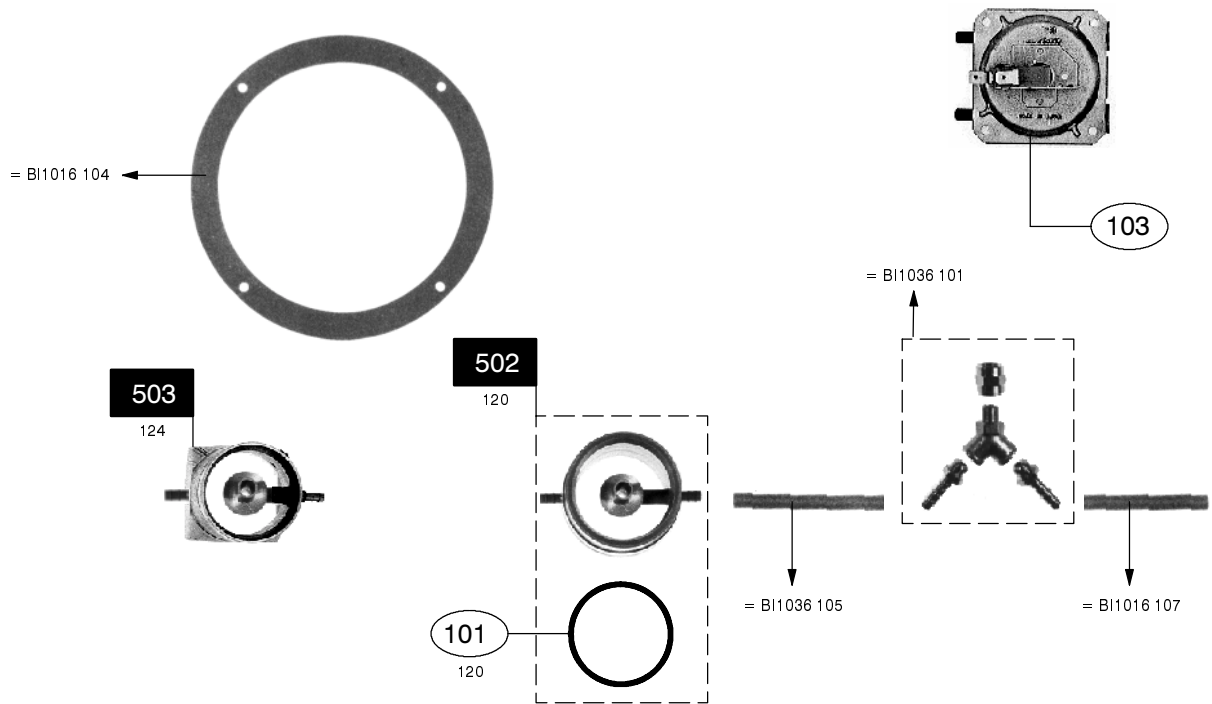

P = Flat packing
R = O-Ring packing

				120MFS					120RFS
				124MFS					



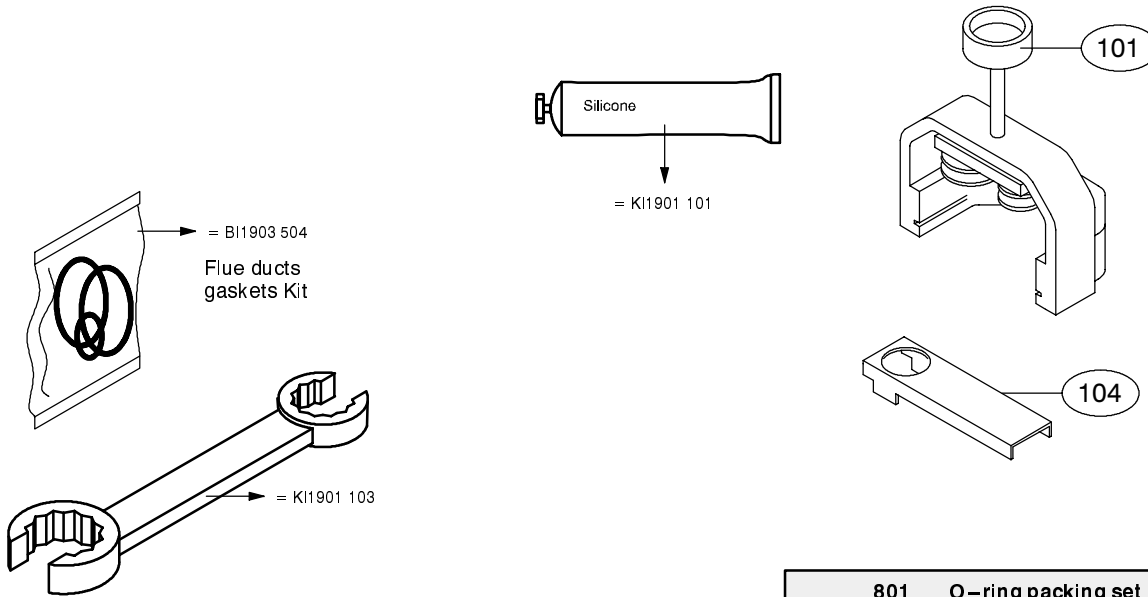

801 O-ring packing set		
KI1043	114 10	17,04 x 3,53
KI1001	130 10	13,95 x 2,62
KI1001	108 10	56,52 x 5,34
KI1031	107 10	43,82 x 5,34
KI1001	109 10	40,65 x 5,34
KI1031	109 10	37,47 x 5,34
KI1042	102 10	5,70 x 1,90
KI1042	109 10	5,28 x 1,78
KI1042	110 10	15,88 x 2,62
KI1002	119 10	6,07 x 1,78
KI1001	128 10	9,25 x 1,78
KI1042	118 10	20,24 x 2,62
KI1002	121 10	10,78 x 2,62
KI1001	105 10	17,13 x 2,62
KI1043	145 10	2,90 x 1,78
KI1004	113 10	26,58 x 3,53
BI1013	101 10	
KI1267	101 10	
KI1043	144 10	18,64 x 3,53

802 Flat packing set		
BI1001	107 10	P E
BI1001	106 10	P B
BI1001	108 10	P A
BI1001	105 10	P F

P = Flat packing
R = O-Ring packing

0798

	120ME		120MFS				120RFS
	124ME		124MFS				



803 Basic spares		
Part	Pos. N.	Description
KI1031	101	5 Fork
KI1031	104	5 Fork
KI1031	110	5 Fork
KI1031	503	1 D.H.W. exchanger
KI1031	504	1 Upper D.H.W. exchanger plung kit
KI1031	505	1 Lower D.H.W. exchanger plung kit
KI1042	112	5 Fork
KI1042	115	5 Fork
KI1042	120	5 Fork
KI1042	122	1 3 way valve motor
KI1042	501	2 Temperature probe kit (NTC)
KI1042	502	3 Flow limiter 8 L. kit
KI1042	504	3 Flow limiter 12 L. kit
KI1042	507	1 D.H.W. water unit
KI1042	509	1 By pass valve kit
KI1042	511	1 Directional valv body
KI1042	514	1 C.H. water unit
KI1043	103	1 Expansion vessel
KI1043	118	1 Pressure switch
KI1043	151	1 3 bar safety valve
KI1093	103	1 Pump kit
KI1093	501	1 Automatic purger kit
KI1064	504	1 G20 injector kit
KI1064	506	1 G30–G31 injector kit
KI1024	155	1 Electrovalve Sit
KI1024	156	1 Electrovalve Sit
KI1024	160	1 Electrovalve Sit
KI1064	505	1 G20 injector kit
KI1064	101	2 Ignition electrode right
KI1064	102	2 Ignition electrode left
KI1064	103	2 Detection electrode
KI1064	104	1 Regulator gas Honeywell
KI1104	101	1 Regulator gas Sit
BI1005	105	10 Fuse 1.6A
KI1006	530	1 Thermo–manometer kit
KI1066	104	1 Overtemperature thermostat
KI1086	102	1 Electronic circuit board SB (80.13)
KI1086	103	1 Electronic circuit board SA (80.12)
KI1156	106	1 Watch
KI1156	107	1 Flue gas thermostat
BI1045	133	1 Electronic circuit board
KI1087	120	1 Fan 120
KI1117	120	1 Fan 124
KI1267	103	1 Flue pressure switch
BI1016	104	1 Gasket
KI1903	101	1 Grease
KI1903	801	1 O–Ring packing set
KI1903	802	1 Flat packing set
KI1903	101	1 D.H.W. extractor kit

P = Flat packing
R = O–Ring packing

	120ME			120MFS					120RFS
	124ME			124MFS					



