



Glow-worm

206300/1/84

~~Installation and Servicing Instructions~~

To be left with user, or at gas meter

CAPRICORN 240/6 Gas Fire Front with either Glow-worm 240 or 246 Back Boiler Unit

G.C. Numbers: Fire Front — 3731406
240 Boiler Unit — 4431526 246 Boiler Unit — 4431525

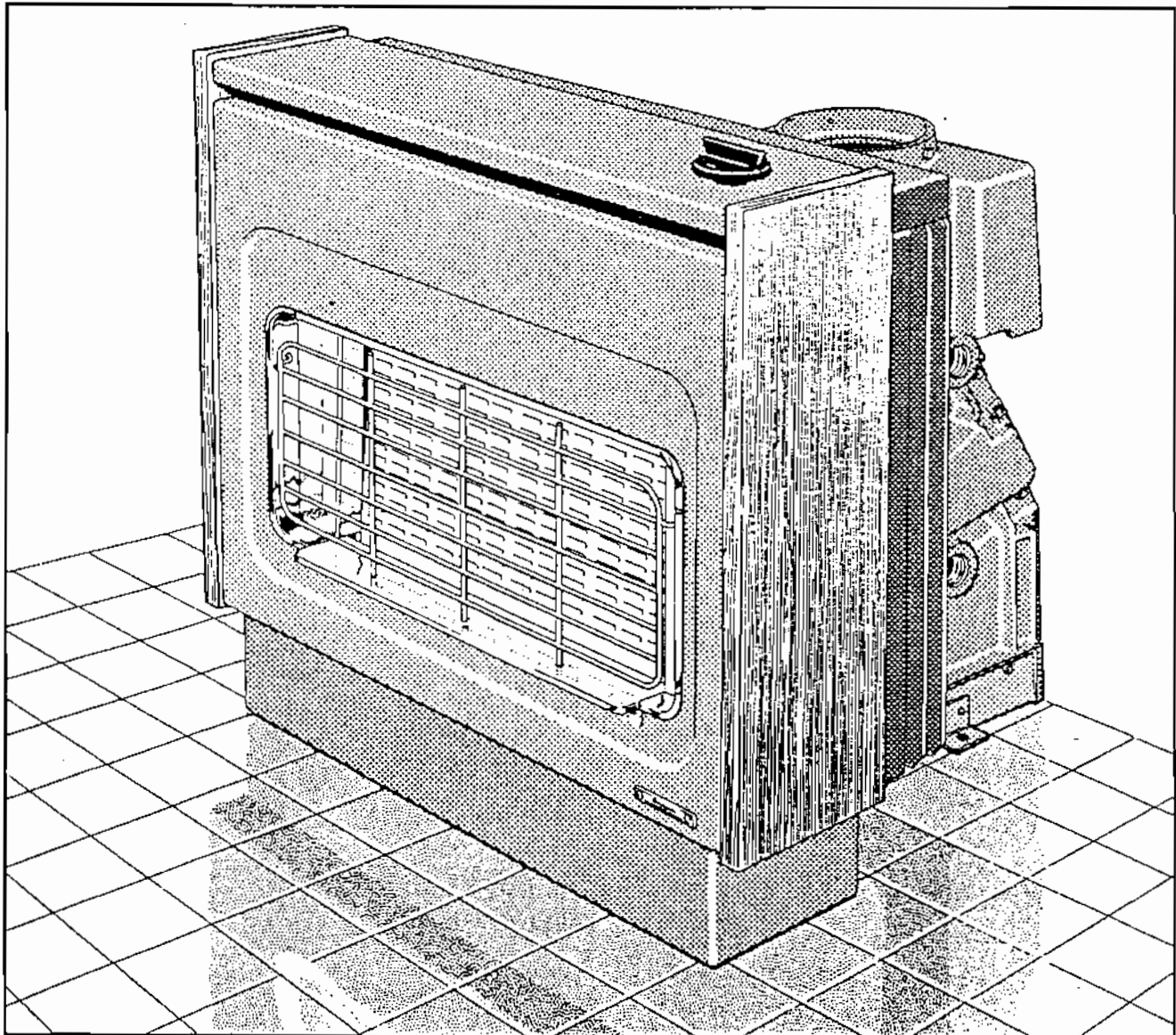

1 SPECIFICATION

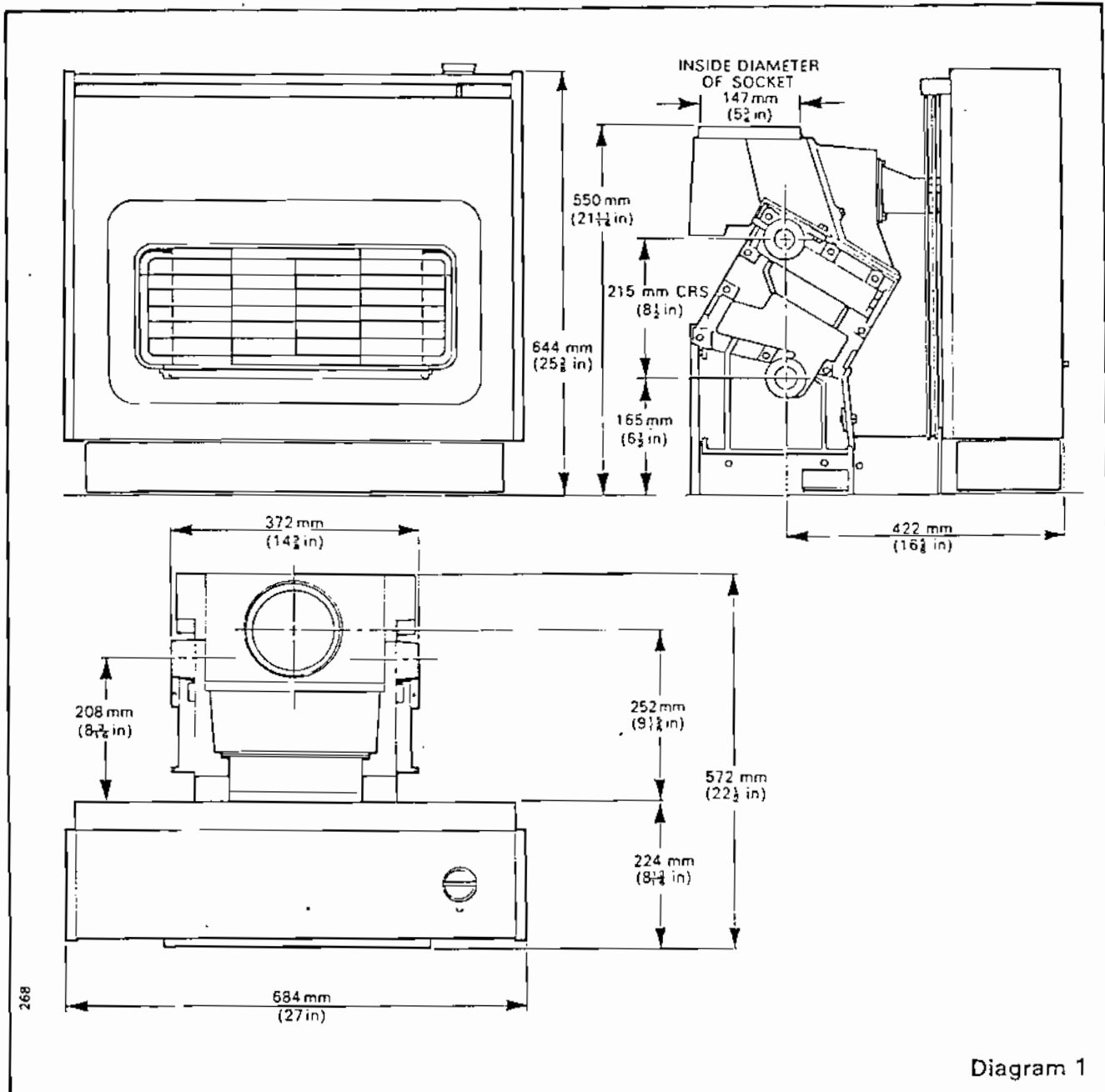

Diagram 1

240 and 246 Boiler Units				
Injector		Furigas 5 holes 1.6 mm diameter		
		240 Boiler		246 Boiler
		min	max	
Input	kW	11.84	15.56	17.9
	Btu/h	40,400	53,100	61,000
Output	kW	8.79	11.72	13.5
	Btu/h	30,000	40,000	46,000
Hot Setting Pressure	m.bar	9.9	16.3	14.1
	in. w.g.	4.0	6.5	5.7

IMPORTANT NOTICE: This appliance is for use on natural gas only and CANNOT be used on any other gas.

CAPRICORN 240/6		
Fire Unit		
Injector		Bray Cat. 28 No. 200
Input	kW	5.9
	Btu/h	20,000
Setting Pressure	m.bar	19.4
	in. w.g.	7.8

2. SITE REQUIREMENTS

The Glow-worm CAPRICORN 240/6 fire together with a 240 or 246 back boiler unit are delivered on site as three separate packages.

The boiler body and base are packed on a pallet, the boiler controls in one container and the fire assembly in a second container.

2.1 THE BUILDER'S OPENING

For all types of installation the appliance requires a standard sized builder's brickwork opening, irrespective of the type of fire surround or mounting used.

That is a clear brickwork opening measuring in plan 580mm (22³/₄in) wide x 359mm (14¹/₈in) deep inclusive of plaster finish.

It is important that the back wall of the builder's opening is cleared of any adhesive debris (mortar, etc.) and that the actual gathering into the 229mm x 229mm (9in x 9in) chimney is at a minimum height of 914mm (36in) above the hearth level.

The required holes for all heating, domestic hot water (and gas pipe where applicable) should be prepared as suggested in diagram 2. The prepared back boiler base must be flat and horizontal.

2.2 NOTES

2.2.1 All electrical wiring must be carried out by a qualified electrician.

All external components shall be of the approved type and shall be wired in accordance with the I.E.E. Regulations.

2.2.2 Electrical supply 240V., 3A., 50Hz.

2.2.3 This boiler shall only be connected to a cistern water supply with a head not exceeding 27 metres (ninety feet) and have an open vent in the system.

2.2.4 The appliance must be earthed, and connections to the mains supply must be through a 3 amp fused double pole isolating switch or spur box, or a shuttered socket outlet and 3 amp fused 3-pin plug. Heat resistant cable of at least 3 amp (16/0.20) capacity having a temperature rating of 90°C minimum must be used for all wiring to the control box.

2.2.5 THE INSTALLATION OF THIS APPLIANCE MUST BE CARRIED OUT BY A QUALIFIED INSTALLER AND MUST BE IN ACCORDANCE WITH THE RELEVANT REQUIREMENTS OF THE GAS SAFETY REGULATIONS, LOCAL BUILDING REGULATIONS, I.E.E. REGULATIONS, THE LOCAL GAS REGION, THE LOCAL AUTHORITY, THE BYELAWS OF THE LOCAL WATER UNDERTAKING AND RELEVANT RECOMMENDATIONS OF BRITISH STANDARD CODES OF PRACTICE CP331 PART 3: 1974, BS 5440 PART 1: 1978, BS 5440 PART 2: 1976, BS 5449 PART 1: 1977, BS 5546 : 1979 and BS 5871 : 1980.

2.2.6 When installing or servicing this appliance, care should be taken when handling the edges of sheet metal parts, to avoid any possibility of injury.

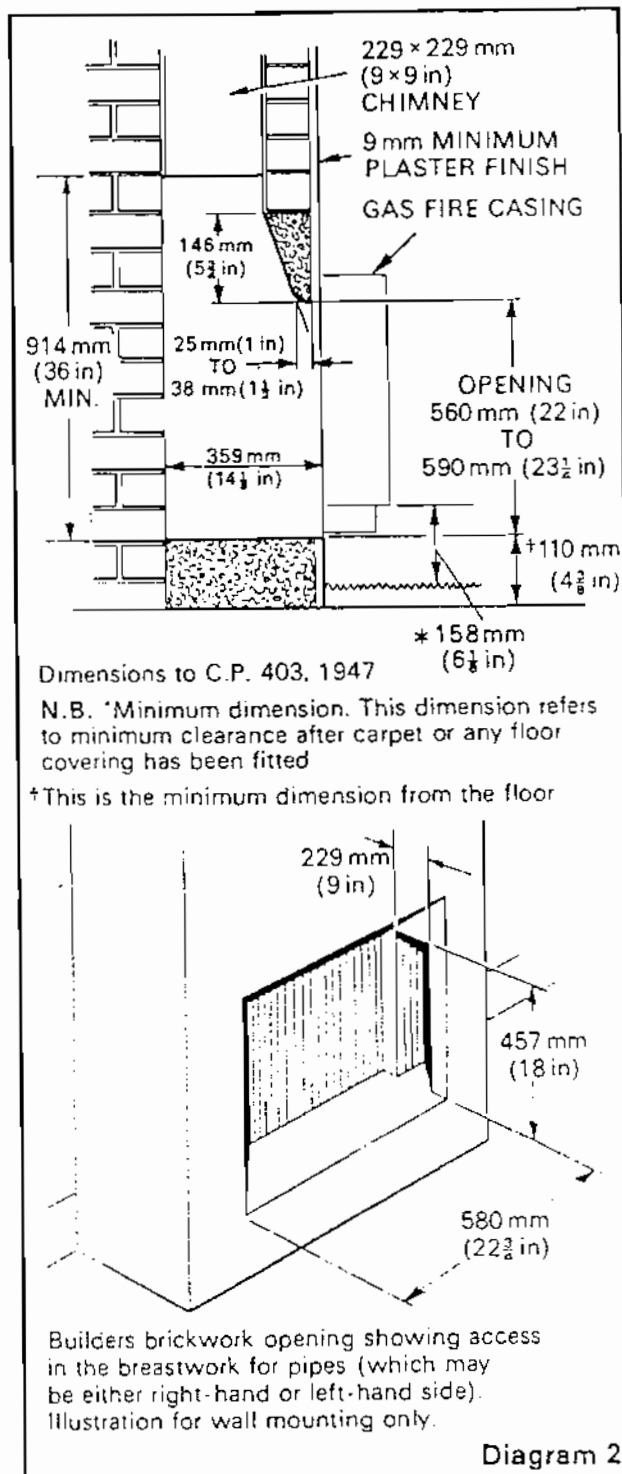

2.3 TYPES OF FIXING

2.3.1 Wall Mounted (that is, without tiled surround).

The builder's opening dimensions given earlier still apply. The frontal opening required is 580mm wide x 590mm high, (22³/₄ x 23¹/₄in) which means that a lintel must be fixed at a height of 590mm (23¹/₄in) above the base of the builder's opening, and the wall is plastered up to the two sides and top to form the 580mm x 590mm frontal access. Wall decorations can be taken right up to the sides of the opening, no further register or closure plate is required.

2 INSTALLATION -- SITING

In this type of installation it is quite normal to carpet the floor directly below the fire, and for this reason it is necessary to arrange the floor of the builder's opening at a minimum height of 110mm ($4\frac{3}{8}$ in) above room floor level to allow the necessary minimum height of 158mm ($6\frac{1}{8}$ in) from floor level to the underside of the fire casing, after carpet or floor covering has been fitted, to avoid over heating of the carpet or unprotected floor fabric.

A hearth manufactured from a fireproof and insulating material with a maximum thermal conductivity of 0.1 to 0.12 Wm/ $^{\circ}$ K and with minimum dimensions of 700mm ($27\frac{1}{2}$ in) wide and 300mm (12in) deep x 12.5mm ($\frac{1}{2}$ in) thick may be fitted provided that a gap of at least 50mm (2in) exists between the hearth and the bottom of the fire plinth.

2.3.2 Tile Surround Fixing

The appliance can be installed with the tiled surround and hearth in position.

All tile surrounds vary in dimensions, it is important therefore to check that the thickness of the existing surround does not bring the boiler too far forwards so that it fouls the flue. It must also have a flat face.

The minimum opening required in the tiled surround is 406mm (16in) wide x 560mm (22in) high. The maximum opening permitted is 580mm ($22\frac{3}{4}$ in) wide x 590mm ($23\frac{1}{4}$ in) high.

The prepared boiler base of the builder's opening **MUST** be level with, or above, the top surface of the hearth to give a minimum gap of 21mm ($\frac{13}{16}$ in) from the bottom of the fire plinth to the hearth. See diagram 3.

2.3.3 A minimum distance of 150mm (6in) must exist between the side of the fire and any fixture.

2.4 THE FLUE

2.4.1 The general recommendations of BS 5440: 1 should be observed. In common with all central heating boilers the integral draught diverter on the back boiler unit makes the combustion performance independent of conditions in the chimney flue. It is essential that the flue be an efficient ventilator for the flue products to ensure a trouble-free installation, with an equivalent height of at least 2.5m (8.2 ft) measured from the flue connection on the appliance.

2.4.2 An existing brick chimney must be thoroughly swept and must be lined with a British Gas approved liner sleeve of 127mm (5in) dia. which must be connected and sealed directly into the flue outlet socket of the boiler.

2.4.3 The termination of the liner at chimney top must be adequately sealed and clamped, using proprietary fittings appropriate to the flue liner used. (See diagram 3).

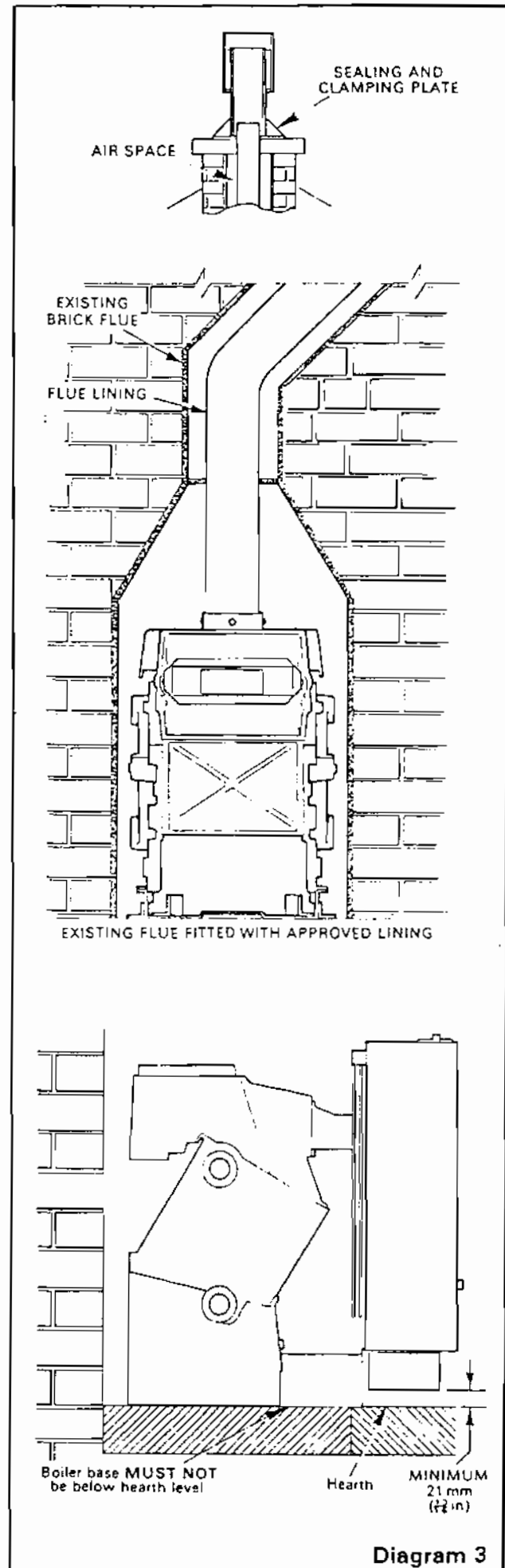

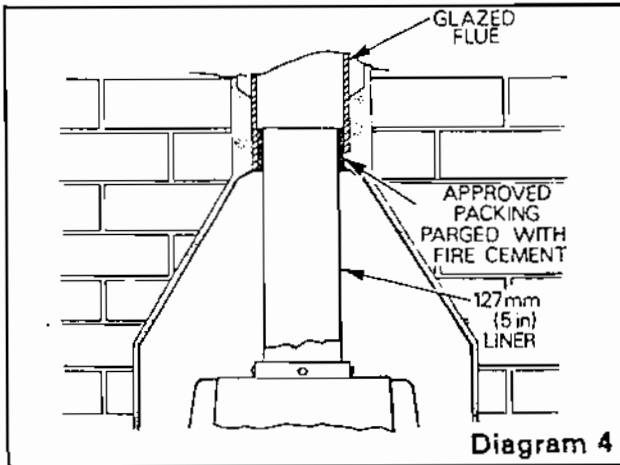

2.4.4 THE EXISTING FLUE MAY NOT BE COMPLETELY SOUND. TO OVERCOME ANY DOUBTS IN THIS RESPECT, ADDITIONAL SEALING MUST BE CARRIED OUT BETWEEN THE BASE OF THE CHIMNEY AND THE FLUE LINER. THIS WILL PREVENT THE POSSIBILITY OF LEAKAGE TO AN ADJACENT FLUE, CAUSING EXCESS AIR TO BE DRAWN THROUGH THE APPLIANCE.

THE SEALING PLATE ALSO PREVENTS DEBRIS FALLING, AND GIVES THE FLUE BETTER INSULATION, REDUCING THE POSSIBILITY OF CONDENSATION. SEE DIAGRAM 3.

2.4.5 A newly built chimney can be lined with a moisture resistant lining, such as salt glazed pipe, of an appropriate diameter as specified in the Building Regulations.

In the case of a 'salt-glazed' lined flue, it is recommended that a short length of flue pipe, possibly flexible metallic as described above, be fixed and sealed to the boiler flue socket, made good with approved packing into the chimney liner and parged with fire cement. (See diagram 4).

2.4.6 All flues must terminate in a British Gas approved terminal. Your local Gas Region will be pleased to advise.

2.5 ROOM VENTILATION

It is important that the room in which the appliance is fixed must have adequate air inlets to ensure correct operation of the appliance. A permanent air vent of effective area 77cm^2 (12in^2) should be fitted. It may communicate direct with outside or with an internal room or space (such as a hall) which is itself provided with a permanent air vent of the same effective area. The permanent air vent should be located in a position which minimises nuisance to occupants due to draughts

2.6 HEATING SYSTEM

The design and installation of the system should be in accordance with British Standard 5449 Pt.1. When used to supply a domestic hot water system combined with a central heating circuit, the hot water cylinder must be indirect. The boiler should never be used on a direct domestic hot water system.

2.7 DRAINING

Key operated taps to BS 2879 should be fitted in accessible positions to facilitate complete emptying of the system, except small dips under doors etc.

2.8 SAFETY VALVE

When fitted it should be adjacent to the boiler on the flow pipe. It should not be possible to isolate the valve from the boiler by any intermediate cock.

2.9 BOILER CONNECTIONS

The boiler body has two Rpl (1" BSP) tappings on each side.

2.10 GAS CONNECTION

The gas installation should comply with the recommendations of CP 331, Parts 2 and 3. The gas supply and meter should be large enough to supply the boiler, together with any other gas appliance connected to them. If in doubt, your local Gas Region should be consulted.

If the gas supply is entering from the right hand side of the appliance, the gas supply should be laid before the boiler is positioned.

If the builder's opening and flue were previously used with a solid fuel appliance, the gas supply pipe within the opening should be protected. A suitable method is to wrap with PVC tape.

Your local Gas Region will advise.

2 INSTALLATION – BOILER FIXING

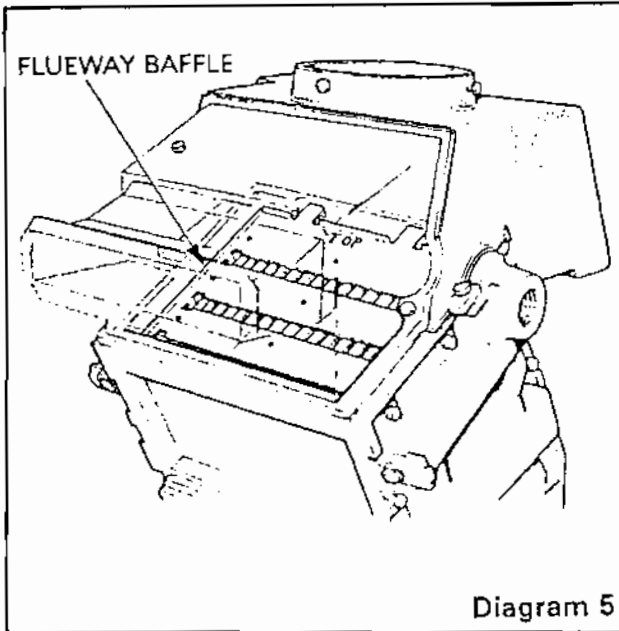

Diagram 5

2.11 BOILER FIXING

It is assumed that the builder's opening has been prepared as described previously.

2.11.1 IMPORTANT. Remove the combustion chamber front cover and extension piece assembly from the boiler body before taking the boiler from the wooden pallet by removing the two slotted hex. head screws and washers securing it to the boiler.

2.11.2 Remove the boiler body and base assembly from its packing.

Check that the flueway baffle has not been dislodged in transit, and is still sitting in the top of the boiler, this can be done by inserting a hand up and through the rear of the draught diverter. (See diagram 5).

2.11.3 Place the boiler in its approximate position, centrally in the builder's opening. The gas fire flue offtake should not be used to lift the boiler. From the fire assembly container remove the formed steel channel, the sheet steel angled template and plastic bag containing phial pocket, 1/2in BSP plug, screws, nuts and metal Rawlplugs.

2.11.4 Attach the gas fire support channel to the top of the gas fire flue duct using the two M6 x 12mm lg. hex. hd. screws, nuts and shakeproof washers. Insert the screws upward through the flue duct into the channel so that the nut and shakeproof washer are uppermost. (See diagram 6). Make sure that the two captive nuts are on the front face of the channel and that it is parallel with the front face of the flue duct.

2.11.5 Check that the front face of the channel overhangs the front face of the flue duct by 3mm, as shown in diagram 6.

The gas fire support channel should NOT be used to lift the boiler.

2.11.6 Offer one end of the flue liner into the boiler flue outlet, mark off and pierce three

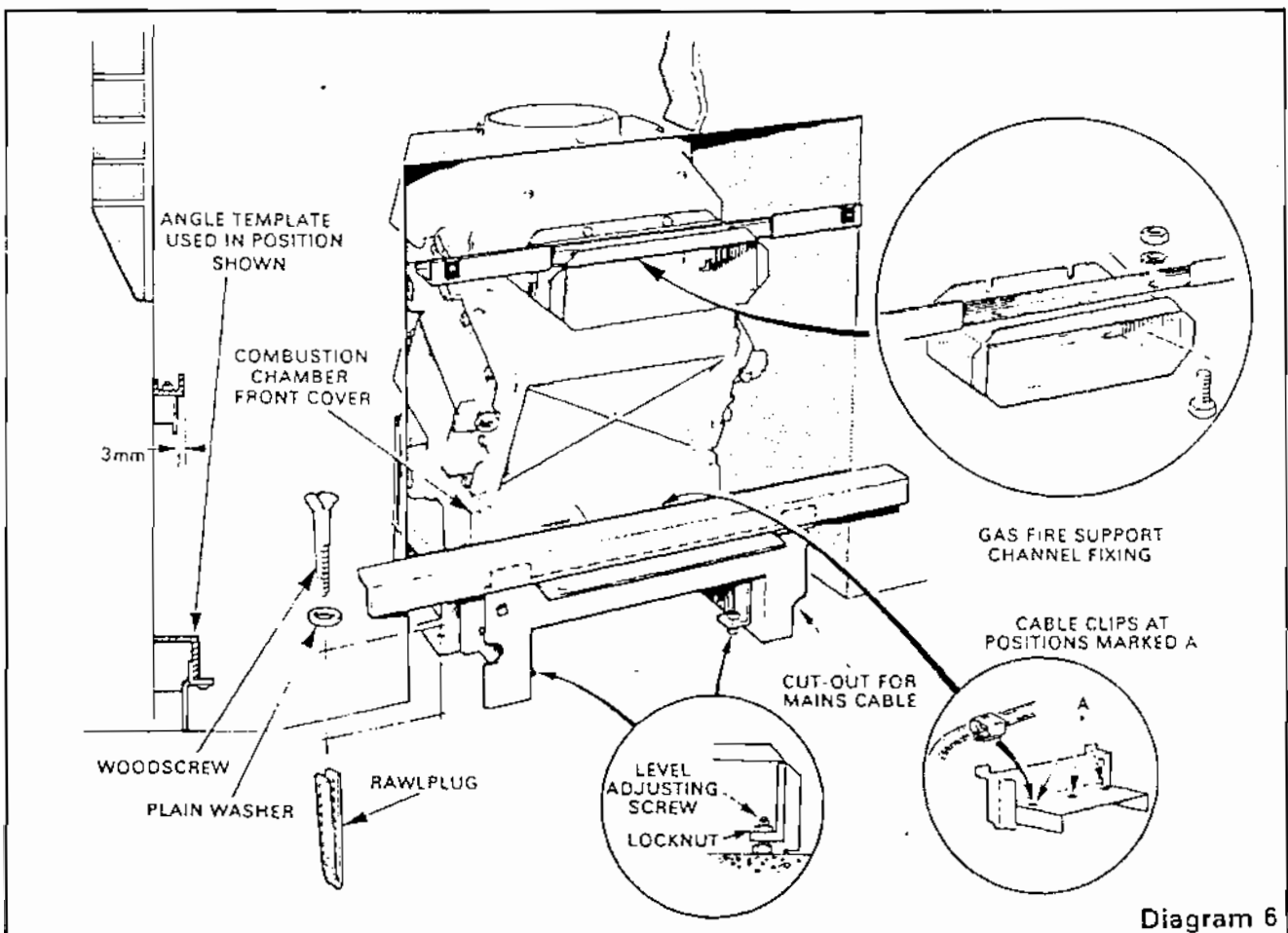

Diagram 6

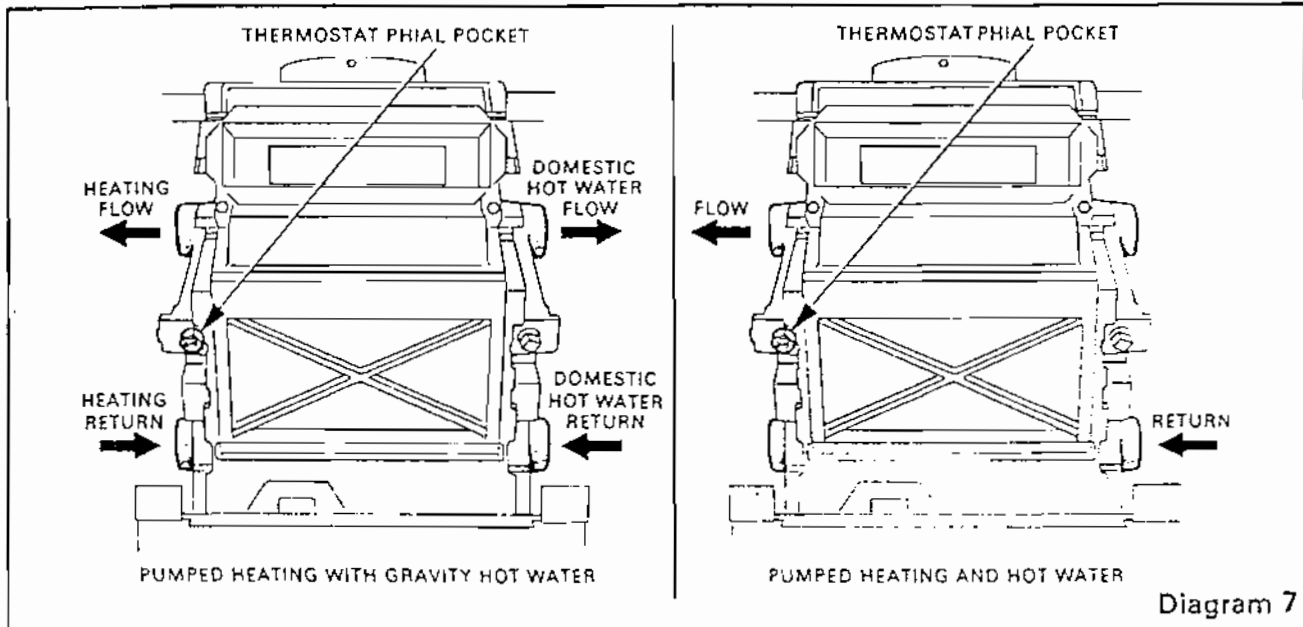

Diagram 7

holes to suit the setscrews in the flue socket, then fit the flue liner into the chimney - leaving the lower pierced end approximately 525mm (20 1/2 in) above hearth level, make good at chimney top and trim off any surplus liner. (See diagram 3).

2.11.7 Re-fit the combustion chamber front cover temporarily with the two slotted hex. head screws and washers previously removed.

2.11.8 Offer up the angle template, as shown in diagram 6, so that the fire support plate is correctly aligned to the finished face of the plastered wall surface or tiled surround. This will ensure that the gas fire rear panel is fitted in the correct position.

2.11.9 Pack under the full width of the boiler base, front or rear as required, to ensure that the boiler is located in the correct position.

2.11.10 After positioning the boiler, use the level adjusting screws shown in diagram 6 to align the gas fire support plate and boiler combustion chamber extension, front to rear and across the width, with the base of the builder's opening.

Levelling screws are for fire support purposes and should only be used after levelling boiler by packing, as required. When adjusted, lock up the screws with the locknuts provided. If further packing up at the front or rear is required, it must be fitted under the full width of the boiler base.

2.11.11 Ensure that the boiler is central in the builder's opening. With the boiler in position, drill through the holes in the brackets each side of the boiler base to take the metal Rawlplugs, and firmly secure the base to the hearth with the 2in x No.12 wood screws and washers provided.

NOTE:- There should be sufficient tolerance in this fixing to allow final adjustment prior to completing the installation. Re-check from time to time with the template, as described earlier, to see that the boiler has not become mis-aligned. Correct as necessary.

2.11.12 Fit the lower end of the flue liner into the flue socket, secure with setscrews and seal with fire cement.

2.12 WATER CONNECTIONS

Fit phial pocket and 1/2 in B.S.P. plug in required positions. See diagram 7.

All water pipes to the boiler can now be installed (see diagram 7).

IT IS EXTREMELY IMPORTANT THAT NO SERVICE PIPES CROSS THE FRONT OF THE COMBUSTION CHAMBER FRONT COVER AND FLUE COLLECTOR, AS THIS WOULD MAKE THE REMOVAL OF THESE COVERS FOR SERVICING IMPOSSIBLE.

No pipework should obscure the bottom of the draught diverter, the phial pocket, or the 1/2" BSP plug in the boiler body. Flush the whole of the system, then fill and vent. Check for water leakage. All pipes within the fireplace opening should be protected. A suitable method is to wrap with PVC tape.

2.13 PUMPED HEATING WITH GRAVITY HOT WATER

It is important that the scheme illustrated in diagram 7 is adopted when the connections are being prepared. The thermostat phial pocket must be fitted into the same side of the boiler as the heating flow connection. The connections may be fitted on opposite sides to that shown, but always in the same relative positions, including the thermostat phial pocket.

2.14 PUMPED HEATING AND HOT WATER

Where single flow and return is taken from the boiler, the thermostat phial pocket must be fitted on the same side as the flow connection is made (See diagram 7). It is important that all connections are made as illustrated in diagram 7. The connections may be fitted on opposite side to that shown, but always in the same relative positions, including the thermostat phial pocket.

2.15 CIRCULATING PUMP

The pump should preferably be fitted in the flow from the boiler.

2 INSTALLATION – BOILER FIXING

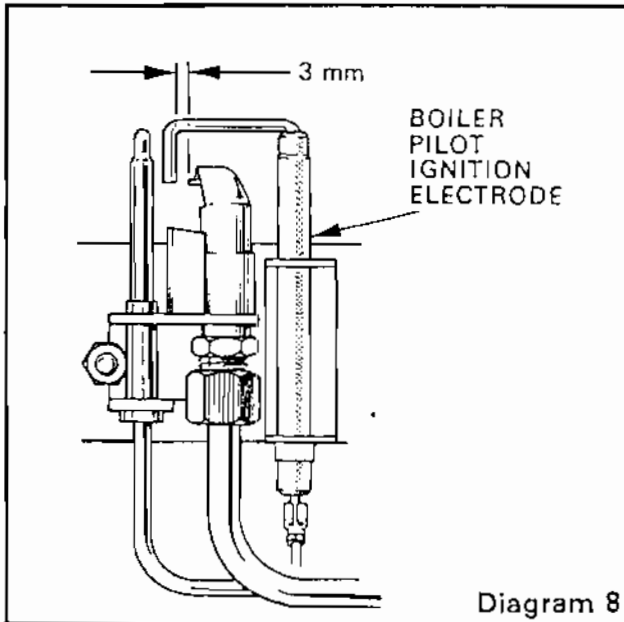
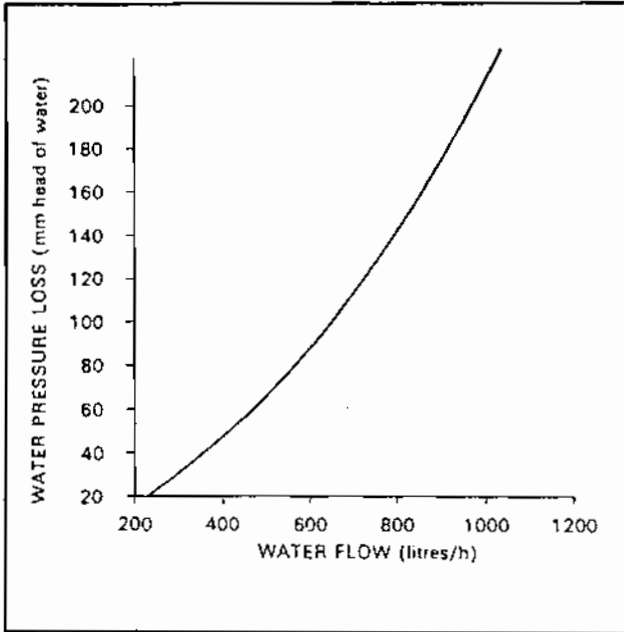

2.16 Check that the flue seal has not been broken.

2.17 CONTROLS

Remove the two slotted hex. hd. screws and washers securing the combustion chamber front cover and extension piece assembly to the boiler body and remove the cover assembly.

2.17.1 Remove the controls and burner assembly from its packing and unscrew the two hex. hd. screws holding the burner supply pipe securing strap to the electrical control box support bracket. Place the electrical control box and burner support tray assembly on to the two studs in the boiler base. Secure with the M6 hex. nuts provided. Take the burner and gas valve assembly and place in position in the boiler base, entering the burner stub end into the location hole at the rear of the burner support tray. Take care not to disturb or damage the pilot burner or electrode. Ensure that the burner bars are horizontal then secure the assembly to the electrical control box

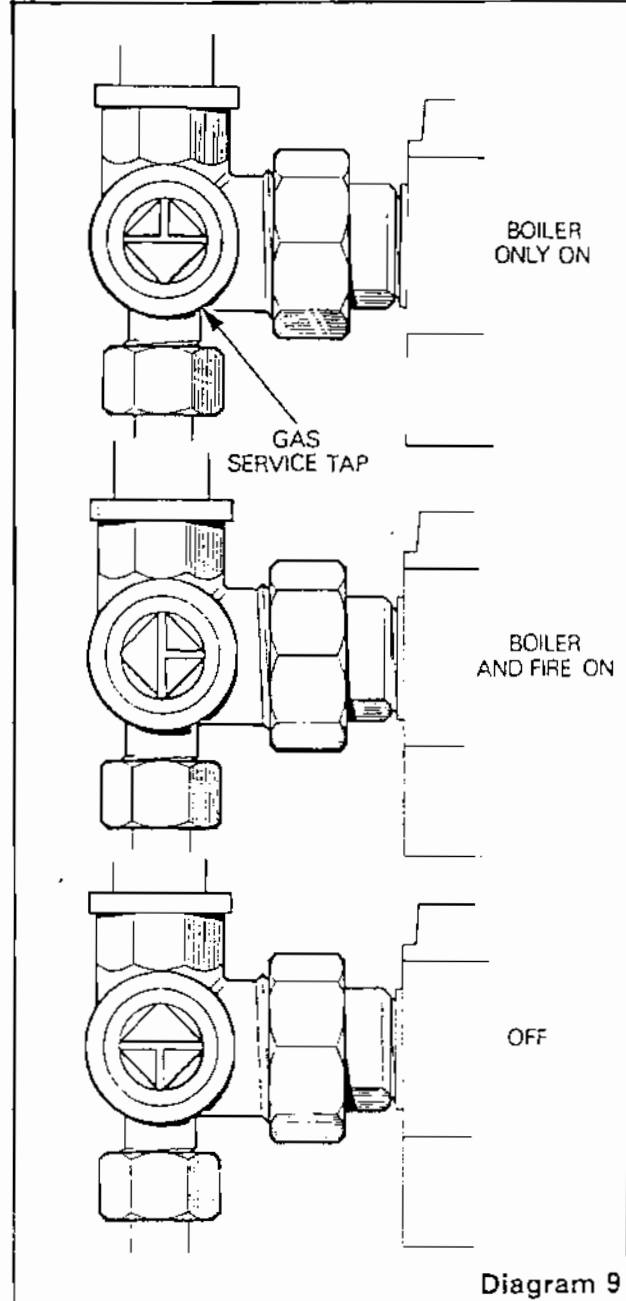

support bracket with the two hex. hd. screws previously removed. Check the boiler ignition electrode position relative to the pilot burner (See Diagram 8).

2.17.2 The gas service pipe run can now be made and connected to the union cock which is packed loose within the fire assembly carton. Assemble the cock to the gas valve in the position shown in diagram 12 and tighten the union nut. The service can now be connected, care being taken to ensure that the service pipe does not impose strain upon the union as this may cause mis-alignment in the build-up.

2.17.3 Re-fit the combustion chamber front cover and extension assembly, ensuring an airtight seal between the cover and the boiler base, with the two M6 hex. hd. screws and washers previously removed.

2.17.4 Ensure that the gas service tap is in the 'OFF' position (See diagram 9) and check for gas soundness.

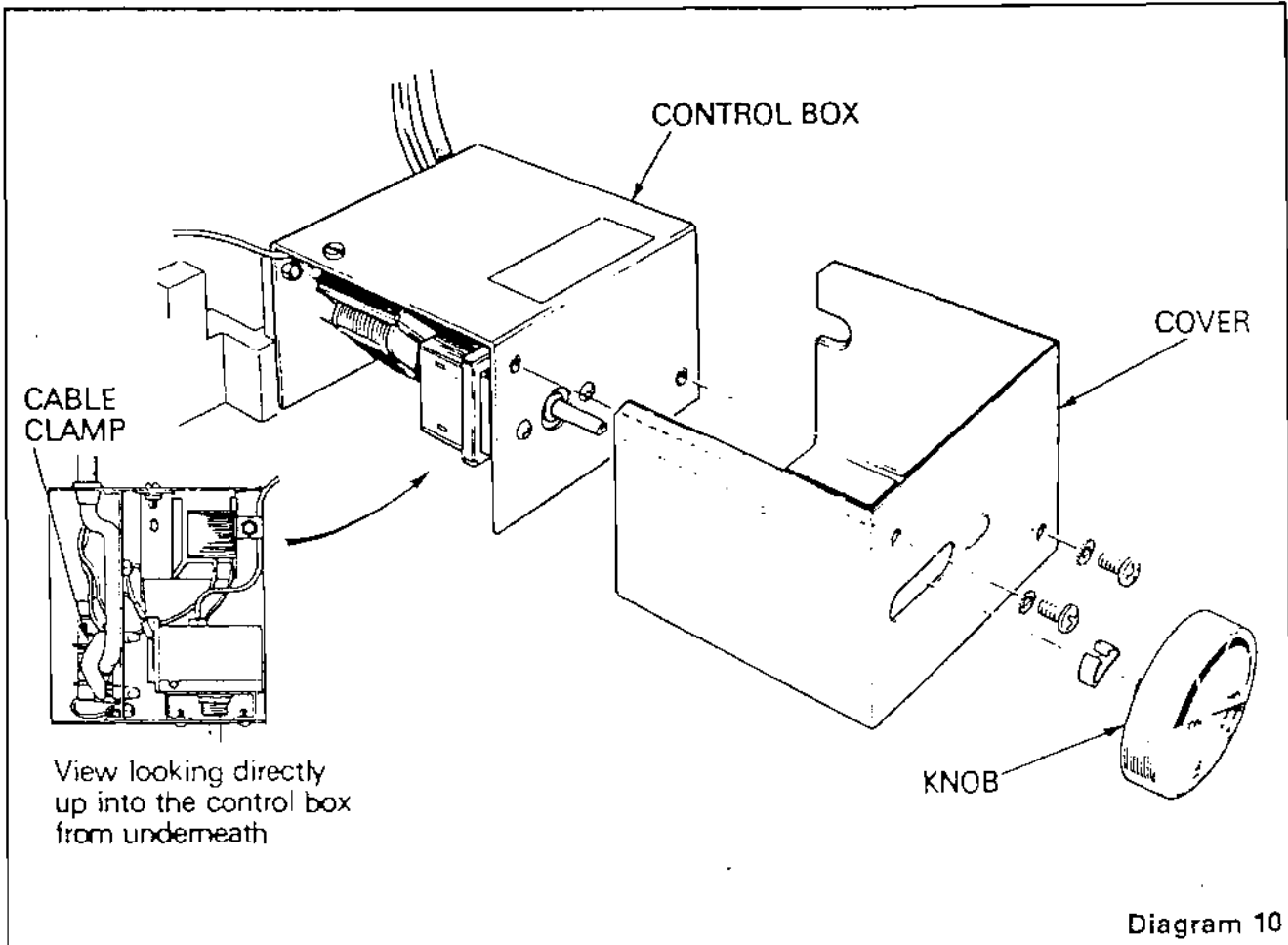

3.1 ELECTRICAL WIRING

Route external wiring to the control box.

NOTE: The mains cable must not cross the fire opening. If concealed wiring is required, i.e. the supply from within the fire opening, for a cable coming from the left-hand side of the opening, run the cable safely away from the hot surfaces by leading it across the front of the combustion chamber extension (see diagram 6), using the three cable clips supplied to fix it at the positions marked 'A'.

A cable entering from the right-hand side of the opening should pass via the cut-out at the bottom right-hand side of the extension piece (see diagram 6).

- 3.1.1 Remove the boiler thermostat control knob by pulling from its spindle (See diagram 10).
- 3.1.2 Remove the two Pozidriv pan hd. screws and shakeproof washers securing the cover to the control box and remove the cover.
- 3.1.3 Bring the mains cable into the control box through the lower grommet in its rear surface. Slacken off the screws holding the mains cable clamp, pass the mains cable through the clamp and connect the three wires to the appropriate terminals in the terminal strip. See diagram 11. Tighten the screws holding the mains cable clamp.

3 INSTALLATION – ELECTRICAL

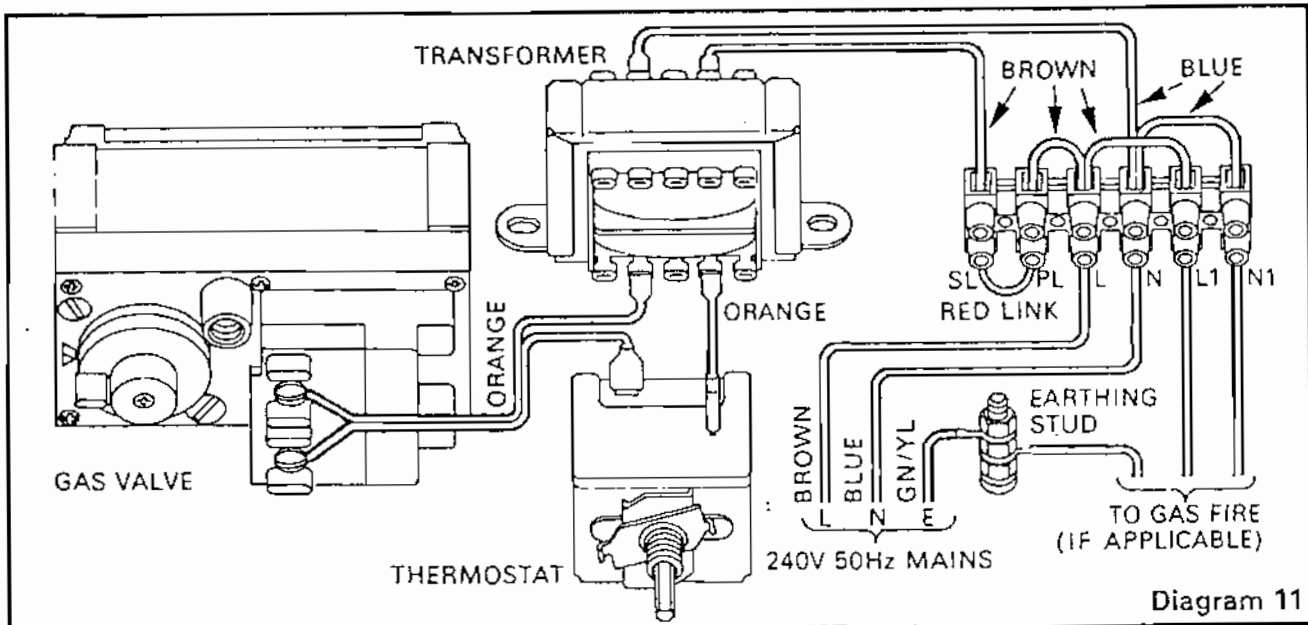

3.1.4 Complete the remainder of the wiring leading all cables in through the grommets, see diagram 11 and schemes 1 to 6, replace the control box cover and screws, then push the boiler thermostat control knob on to its spindle. Reconnect the ignition lead to the piezo unit and the gas valve leads to the gas valve.

3.1.5 Fit the boiler thermostat phial into the phial pocket. Ensure that it is inserted fully into the pocket and retained with the fix provided. The capillary should be positioned to pass vertically down the side of the boiler and then horizontally along the base unit.

NOTE: When the thermostat phial is fitted on the left-hand side, route and secure the capillary as shown in diagram 12, using the clip provided.

3.3 PRELIMINARY ELECTRIC SYSTEM CHECKS

At this stage preliminary system checks must be carried out i.e. earth continuity, polarity and resistance to earth as described in the British Gas Multimeter Instruction Book.

Gravity hot water, pumped central heating (ten position programmer).
Remove red link between SL and PL.

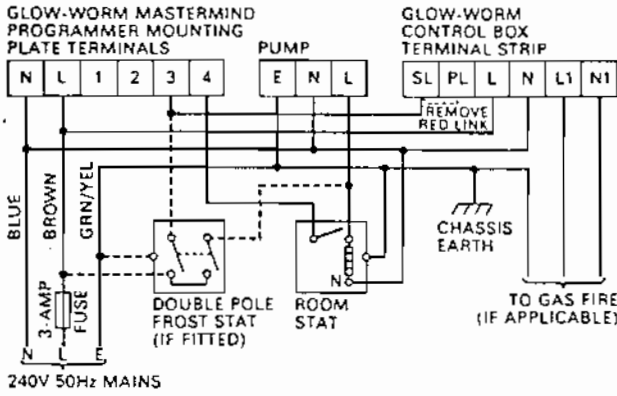

Scheme 1

Wiring diagram for fitting the Honeywell Sundial Plan Y.

NOTE: The piping arrangement and the installation of the controls should be in accordance with the Honeywell instructions.
Remove red link between SL and PL.

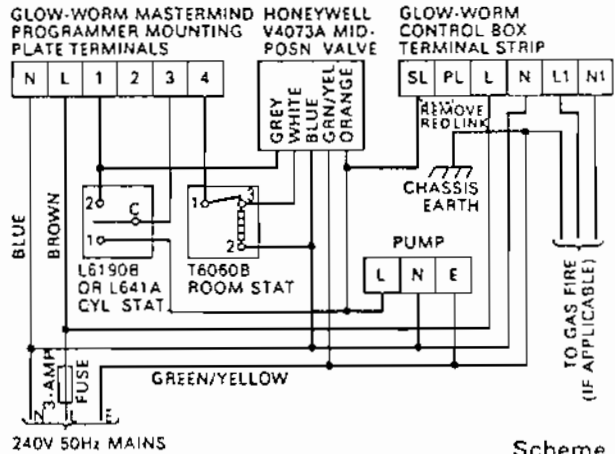

Scheme 2

Domestic hot water and central heating, both pumped, using a Drayton flow-share valve.
Remove red link between SL and PL.

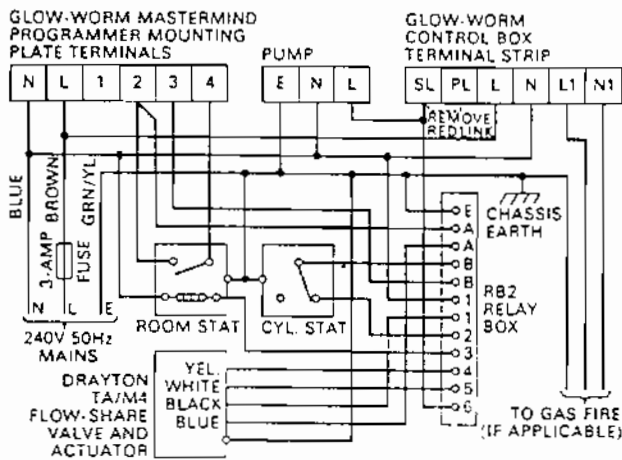

Scheme 3

Wiring diagram for fitting the Satchwell Duoflow system, using the sixteen position programmer. Remove red link between SL and PL.

Remove link A and B from RJ 2802 wiring centre.

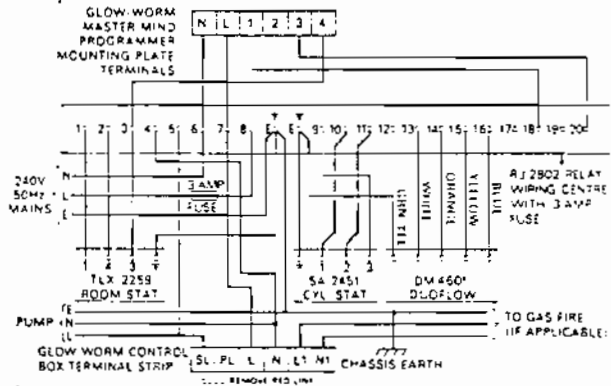

Scheme 4

Independent control of domestic hot water and central heating, both pumped, using two motorised valves (sixteen position programmer).
Remove red link between SL and PL.

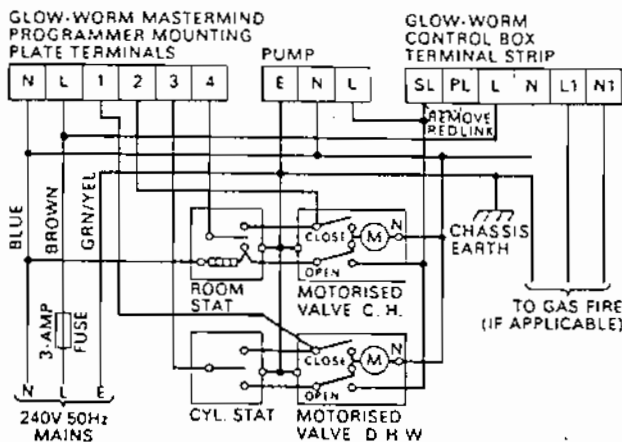

Scheme 5

Independent control of domestic hot water and central heating, both pumped, using two spring return motorised valves (sixteen position programmer).
Remove red link between SL and PL.

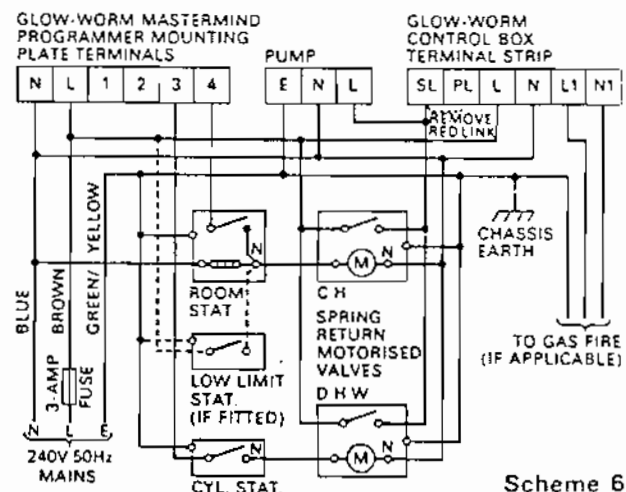

Scheme 6

4 COMMISSIONING — BOILER

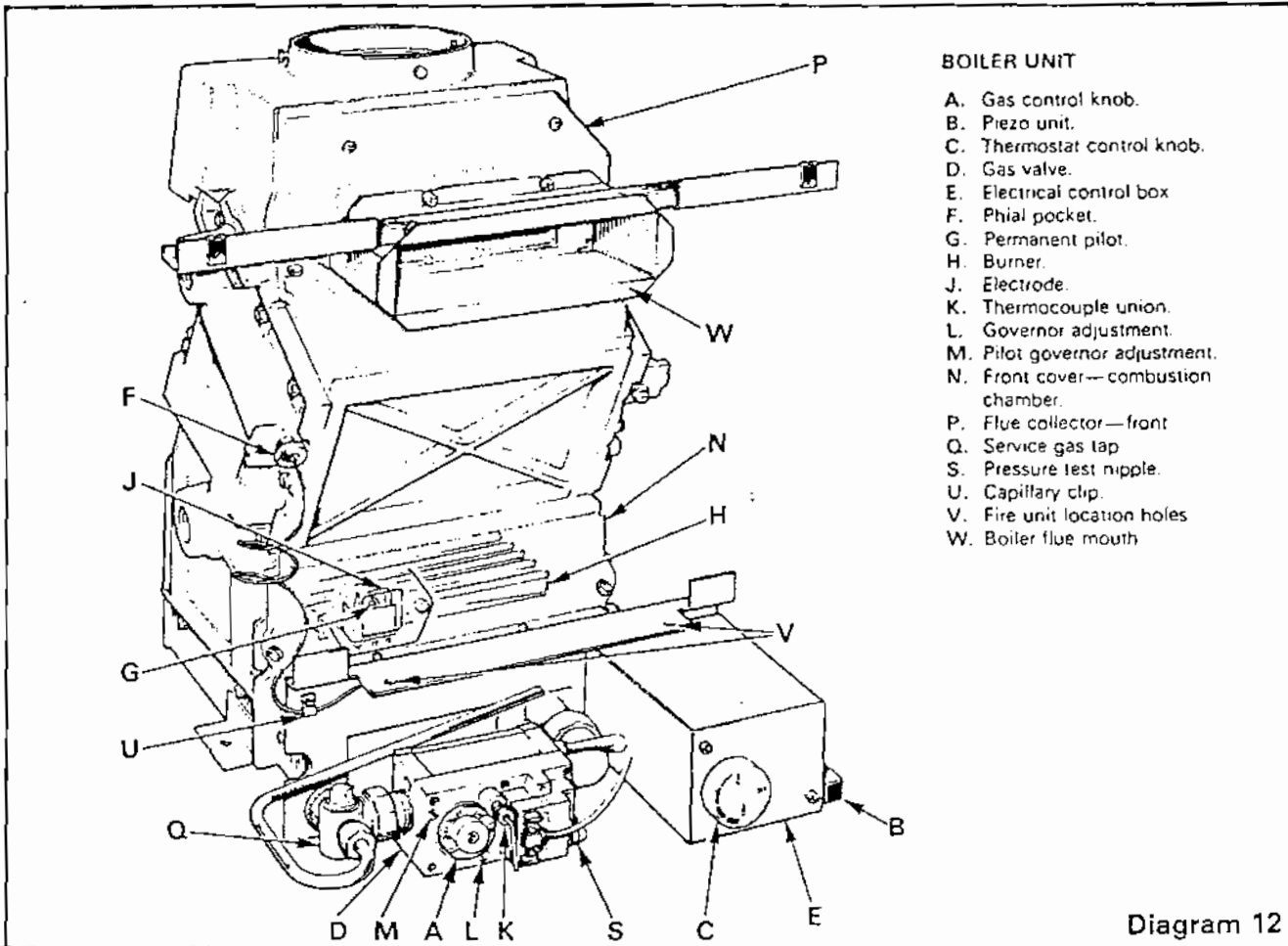

Diagram 12

4.1 INITIAL LIGHTING AND ADJUSTMENT OF BOILER

CAUTION: The following procedure should be carried out by a qualified gas service engineer. The pipes and fittings to the gas control and burner and to some extent the gas pipe to the appliance will contain an appreciable amount of air. It is, therefore, necessary to purge the air from the pipes before the appliance can operate normally. Purging should be carried out as described in CP 331 Part 3. Identify the boiler controls with relevant details on diagram 12.

- 4.1.1 Set all the controls to the 'OFF' position. Turn the gas service tap to the "Boiler only on" position (See diagram 9).
- 4.1.2 Remove the gas pressure test nipple screw 'S' (See diagram 12), and fit a suitable pressure gauge. Switch on the electrical power to the boiler. Ensure that the boiler thermostat knob 'C' is in the 'OFF' position. Set the boiler gas valve control knob to the pilot position, depress and hold in. Press and release the piezo unit button 'B', a single spark should ignite the pilot burner. Hold the boiler gas valve control knob in for one minute. The boiler gas valve control knob can then be released.
- 4.1.3 Adjust the pilot flame as necessary at the gas valve adjustment screw 'M' (see diagram 16). After removing the cover, turn screw, until a pilot flame length of 25mm (1in) is obtained.
- 4.1.4 The thermocouple should be enveloped 10mm to 13mm (3/8 in to 1/2 in) by the pilot flame. Turn anticlockwise to increase. When the pilot is stable and set, turn the boiler gas valve control knob 'A' to the 'ON' position and ensure that all other controls are set for heating. Then turn the boiler thermostat control knob 'C' to the 'Max'. The burner should light smoothly and the primary cones should be well defined when the pressure setting has been adjusted at the governor screw 'L' to the correct gas pressure, see page 2.
- 4.1.5 Turn the boiler thermostat to 'OFF'. Remove the pressure gauge and replace the gas pressure test nipple screw.
- 4.1.6 Turn the boiler thermostat to 'MAX' and allow system to reach maximum operating temperature. Examine the whole system for leaks, turn boiler thermostat to 'OFF' and then drain whilst still hot to give final effective flushing. Re-fill and vent. Give final examination for leaks.

4.2 INSTALLATION - FIRE

4.2.1 Remove the gas fire unit from its packing by opening the four carton flaps outward and turning the complete unit and carton up the correct way. The carton can then be lifted off leaving the fire unit standing in its base packing. Remove the dressguard by easing it forward in the centre until the side location wires are clear of the reflector and pulling forward at the top and upward. Remove the radiant packing piece and the radiants. Lift the gas fire unit from its base packing and lay the assembly on its back on the floor.

4.2.2 Remove the gas fire control knob by pulling it off the spindle. The casing can now be removed from the fire heat exchanger and rear panel assembly by unscrewing the two lower casing securing screws, positioned just below the bottom reflector strip, (see diagram 13).

4.2.3 Pull the bottom of the casing forward slightly and raise the casing approximately 13mm (1/2in), easing the bottom forward and lifting vertically to clear the spindle.

4.2.4 Unscrew the four Pozidriv pan head screws securing the inclined upper casing protection plate to the sides of the rear panel and remove the protection plate.

4.2.5 Remove the two louvres from the packing and fit on to the sides of the fire heat exchanger and rear panel assembly by engaging the louvre brackets in the slotted locations in the rear panel (see diagram 14).

4.2.6 Lower the fire heat exchanger and rear panel assembly on to the combustion chamber extension piece, tilting the top of the assembly forward slightly, ensuring that the dowels on the bottom of the heat exchanger assembly locate in the holes in the extension piece, and incline backward to make a seal between the fire flue spigot and the boiler flue mouth. Secure the fire heat exchanger assembly to the fire support channel with the two M6 x 20mm lg. slotted hex head dogpoint screws and M6 large dia. plain washers provided in positions

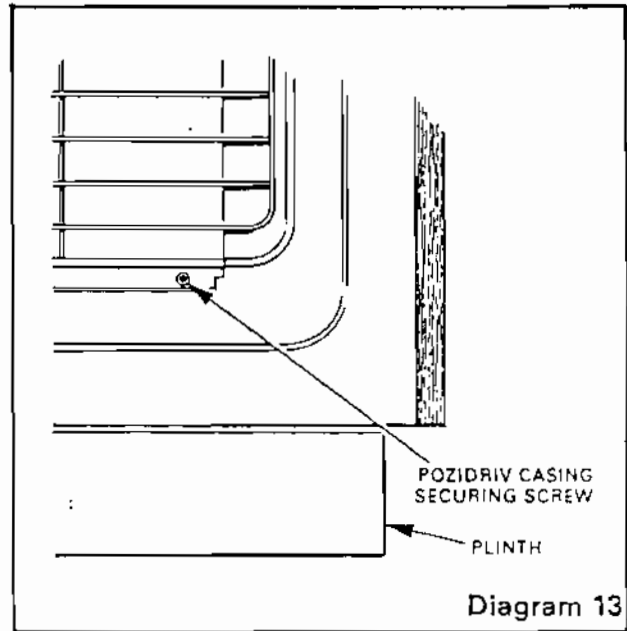

Diagram 13

shown in diagram 14. Connect the gas fire supply pipe to the union gas cock at the left hand side of the fire by means of the tubing nut.

4.2.7 Check that all the joints on the gas fire supply pipe are secure and gas tight.

4.2.8 Re-fit the upper casing protection plate to the sides of the rear panel, using the four Pozidriv pan head screws previously removed.

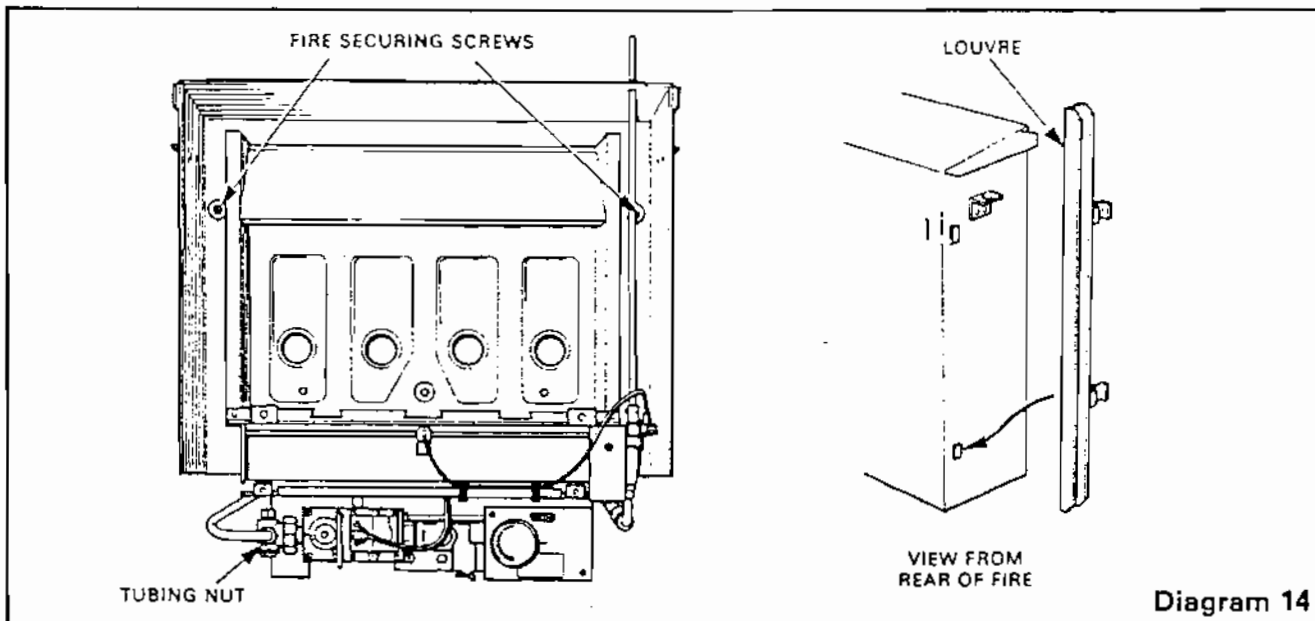

Diagram 14

5 COMMISSIONING – FIRE

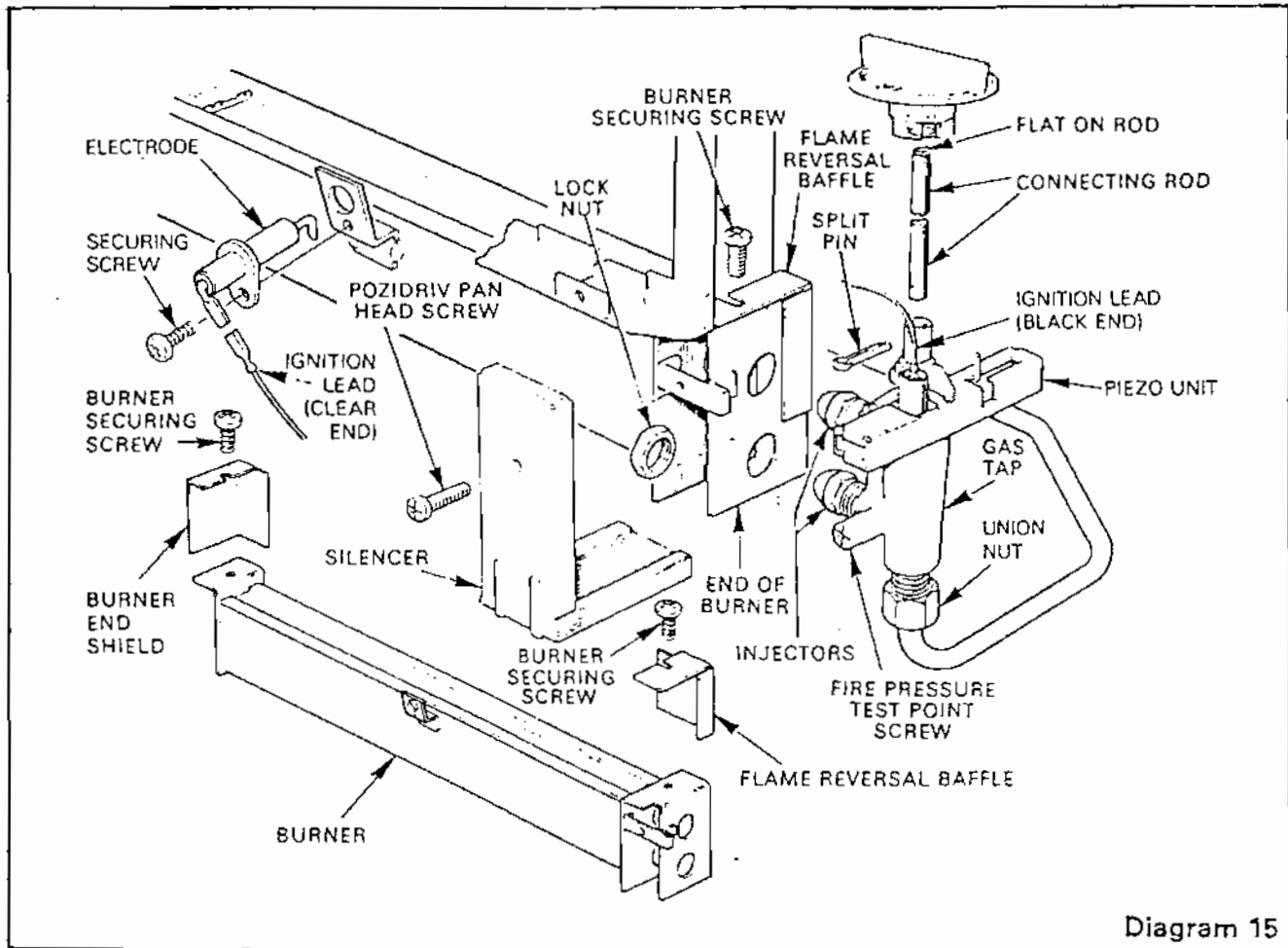

Diagram 15

5.1 INITIAL LIGHTING AND TESTING OF FIRE

- 5.1.1 Set all controls to the 'OFF' position.
- 5.1.2 Fit the gas fire control knob temporarily to the connecting rod. Ensure the gas fire is turned off. The 'OFF' on the control knob should be facing the front of the fire. Remove the gas fire test point screw from the gas fire tap, (See diagram 15), and fit the pressure gauge. Turn the gas service tap to the "Boiler and fire on" position, (See diagram 9) ensuring that all other controls are set for heating. Turn the boiler thermostat to 'MAX' to re-light the boiler burner. Light the fire by pushing in the fire control knob and turning fully anti-clockwise until the "HIGH" marking is facing the front of the fire. (See diagram 16).
- 5.1.3 The fire burner should now be alight. If the fire fails to light it may be due to air being present in the gas fire piping which may require purging.
- NOTE: On the CAPRICORN 240/6 the gas fire pressure is pre-set at the factory and can be checked only.
- 5.1.4 The primary cones on the gas fire burner should be 27mm (3/4 in) to 24mm (1in) in height with a clean burner. Turn off the fire by turning the control knob fully clockwise depressing slightly to pass 'LOW' and remove the control knob.
- 5.1.5 Turn the boiler thermostat to the 'OFF' position, remove the pressure gauge and replace the test point screw.

- 5.1.6 Fit the gas fire radiants by offering the top upwards into the heat exchanger, before pushing backwards and lowering on to the support strip.

5.2 CASING FITTING

Lower the gas fire casing on to the heat exchanger assembly, tilting the bottom forward slightly, so that the dowels in the brackets on the sides of the casing locate in the holes in the brackets on the sides of the fire rear panel. Ensure that the gas control tap connecting rod passes through the hole in the casing top.

- 5.2.1 Secure the casing with the two Pozidriv screws, positioned just below the bottom reflector strip, (See diagram 13).

- 5.2.3 Fit the fire control knob to the rod.

5.3 NORMAL BOILER LIGHTING PROCEDURE

It is assumed that the assembly and initial commissioning have been completed in accordance with the described procedure.

- 5.3.1 Turn on the gas and electricity at the supply point outside the unit.
- 5.3.2 See that all other controls are set for heating. The clock, room thermostat and programmer, if fitted, will be situated away from the unit.
- 5.3.3 Turn thermostat knob 'C' to the 'OFF' position (See diagram 12).

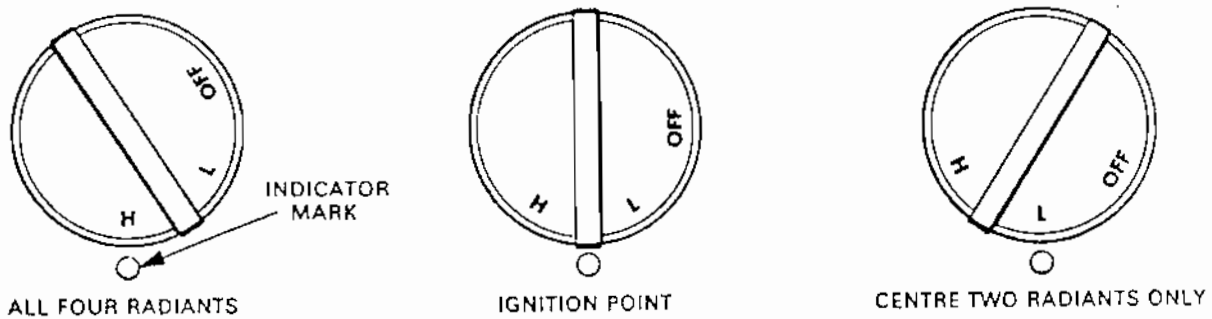

Diagram 16

- 5.3.4 Turn the boiler gas control knob 'A' until 'PILOT' is opposite the red arrow.
- 5.3.5 Push in knob 'A' as far as it will go, and hold it there.
- 5.3.6 Press and release ignition button 'B' until the pilot burner is lit, and keep knob 'A' pushed in for approx. 20 secs. Look underneath the fire casing above the gas control valve for a circular viewing aperture where the pilot flame should be visible.
- 5.3.7 If pilot fails to light or to remain alight, do not force knob 'A' from the 'OFF' position, wait three minutes, then repeat from 5.3.4
- 5.3.8 Make sure that the burner pilot is alight and stable, and then turn gas control knob 'A' to the 'ON' position. Set the boiler thermostat to maximum. The main burner will light at once.

5.4 NORMAL FIRE LIGHTING PROCEDURE

The fire spark ignition is actuated by pushing down the gas tap control knob and rotating it anticlockwise. Ignition then occurs as the bar between 'H' and 'L' on the knob passes the indicator mark, (See diagram 16).

To light the fire, push in and turn the control knob fully anticlockwise to the 'H' position as indicated by the mark. All four radiants will light. If the fire fails to light, turn the knob to the 'OFF' position and repeat the above lighting sequence.

To adjust the heat from the fire after it has been lit, turn the control knob clockwise to the 'L' position. The centre two radiants only will be alight. (See diagram 16).

5.5 TO TURN OFF

Turn the gas tap knob fully clockwise, depressing slightly to pass 'L' position to reach "OFF".

6 CONTROL CHECK-OUT

6. CONTROL CHECK-OUT

After the initial lighting and adjustments have been carried out, the following check-out procedures may be used to ensure the correct operation of the controls.

6.1 OPERATION OF THERMOSTAT

6.1.1 With the main burner alight, turn the thermostat knob to the 'OFF' position. Result - the main burner should shut off.

6.1.2 Turn thermostat knob to the original setting. Result - the main burner should re-light.

6.2 OPERATION OF FLAME FAILURE DEVICE

With the main burner alight, turn the gas control knob 'A' to the 'OFF' position. After one minute the flame failure device should have closed. (A click from the control valve will indicate its operation). After the flame failure device has closed, it will be possible to re-set knob 'A' back to pilot position.

It should not be possible to re-light the appliance without following the sequence of the Users' Lighting Instructions detailed earlier.

6.3 TO EXTINGUISH THE BOILER BURNER

The burner may be extinguished and re-established in any of the following ways:

6.3.1 By turning gas control knob 'A' to the 'OFF' position. This results in complete shut-down of both main and pilot burners. Thermostat knob 'C' should be turned to the 'OFF' position to de-energise the gas control electric operator leaving the electric clock running, but not controlling.

Follow the User's Lighting Instructions to re-light when THREE MINUTES have elapsed.

6.3.2 By turning the gas control knob 'A' to the 'pilot' position. This shuts off the main burner only. Thermostat knob 'C' should be turned to the 'OFF' position, as above; electric clock running, but not controlling, pilot burner alight. Re-light by turning gas control knob 'A' to the 'ON' position, re-set thermostat knob 'C' to the required temperature.

6.3.3 By turning the thermostat knob 'C' to 'OFF' position. This shuts off the main burner, only, leaving the electric clock running, but not controlling, and the pilot burner alight.

Re-light by turning thermostat knob 'C' to the required temperature.

6.3.4 By switching off the electricity supply. This cuts out all electrical controls and the main burner, leaving the pilot burner alight. Re-light by switching on the electricity supply. Re-set electric clock to correct time.

6.4 SETTING OF FIRE

Having completed the boiler control check-out, re-light the boiler burner and set the control devices to maintain the boiler burner on whilst the fire burner is checked for ignition.

6.5 PLINTH FITTING

Engage the upper return flanges of the plinth in the channels in the casing base and slide the plinth backwards as far as it will go.

6.6 In the event of an electrical fault after installation of the appliance, preliminary system checks must be carried out, i.e. earth, continuity, polarity and resistance to earth as described in the British Gas Multimeter Instruction Book.

6.7 INSTRUCT USER IN THE CORRECT OPERATION OF THE APPLIANCE.

IT IS MOST IMPORTANT THAT THE INSTALLER SHOULD DESCRIBE TO THE USER THE CONTROL SCHEME WHICH HAS BEEN INSTALLED. HAND THE 'NOTES FOR USERS' TO THE USER AND ENSURE THAT HE UNDERSTANDS HOW TO OPERATE THE USER'S CONTROLS.

ADVISE THE USER THAT ANY SMELL WHICH IS NOTICED AT FIRST FIRING IS DUE TO NEWNESS. LEAVE THIS BOOK WITH THE USER, OR AT THE METER.

7. SERVICING

Servicing in general must be carried out by a qualified gas service engineer, and where appropriate by a qualified electrician. Before commencing a service, ISOLATE THE GAS AND ELECTRICITY SUPPLIES TO THE APPLIANCE. AFTER SERVICING, ALWAYS TEST FOR GAS SOUNDNESS.

All components are replaced in reverse order to that described for dismantling.

7.1 GAS CONTROL VALVE

The servicing of this control should only be undertaken by an engineer conversant in every respect with the equipment. Thermocouple union 'K' should be tightened only a quarter turn beyond finger tight to give good electrical continuity. Do not tighten further or damage may result.

7.2 BOILER FLUEWAYS

Regular cleaning of the boiler flue passages is necessary for efficient operation. Thorough cleaning should take place annually, preferably at the end of the heating season. The following directions should be followed to ensure correct servicing procedure.

- 7.2.1 Ensure the gas fire control knob is turned to the 'OFF' position, then remove the control knob by pulling it vertically off the spindle. Unscrew the two lower casing securing screws, positioned just below the bottom reflector strip, (see diagram 13). Pull the bottom of the casing forward slightly and raise the casing approximately 13mm (1/2in), easing the bottom forward and lifting vertically to clear the spindle.
- 7.2.2 Remove the plinth by withdrawing it forwards.
- 7.2.3 Turn the gas service tap 'Q' to the 'OFF' position (See diagram 9). Remove the four Pozidriv pan head screws securing the inclined upper casing protection plate to the sides of the rear panel and remove the protection plate.
- 7.2.4 Remove the two side louvres from the slotted locations in the rear panel, (See diagram 14).
- 7.2.5 Unscrew the tubing nut securing the gas fire supply pipe and disconnect pipe from gas service tap. Remove the two slotted hex. head screws and washers securing the fire assembly to the fire support channel (See diagram 14). The top of the fire assembly can now be tilted forward slightly at the top to clear the flue duct, and lifted vertically to disengage the dowel location at the base of the fire assembly.
- 7.2.6 Release the thermostat capillary from its clip on the fire support plate, (See diagram 12). This is only necessary when the thermostat phial is fitted into the left-hand side of the boiler. Remove the phial from its pocket.
- 7.2.7 Remove the two M6 hex hd. screws and M6 washers securing the front cover and combustion chamber extension to the boiler body and remove the cover assembly, taking

care not to damage the seal to the boiler body. Disconnect the electrical connections to the gas valve and disconnect the spark ignition lead at the spark generator.

- 7.2.8 Disconnect the union at the service tap and unscrew the two M6 hex. head screws holding the burner supply pipe securing strap to the control box support bracket. Remove the gas valve and burner assembly from the boiler base by lifting slightly and withdrawing forward over the top of the control box. Take care not to damage the pilot burner or spark electrode.
 - 7.2.9 Unscrew the two M6 brass hex. head screws securing the front half of the flue collector to the rear half and remove the complete assembly of fire support channel, fire flue duct and flue collector front. Do not damage the seal.
 - 7.2.10 Lift out the flueway baffle and clean out the flueway passages from top to bottom, using a suitable stiff brush. A sheet of paper placed in the boiler combustion chamber will help in collecting the dust.
 - 7.2.11 When refitting the baffle ensure that it is correctly fitted, the word 'Top' must be at the top rear of the boiler waterway. The baffle must be pushed down into the flueways. (See diagram 5).
- NOTE: When re-fitting the thermostat phial ensure that it is inserted fully into its pocket and retained with the fix provided. If the phial pocket is fitted on the left-hand side of the boiler secure the capillary in the clip as shown in diagram 12.

7 MAINTENANCE – SERVICING

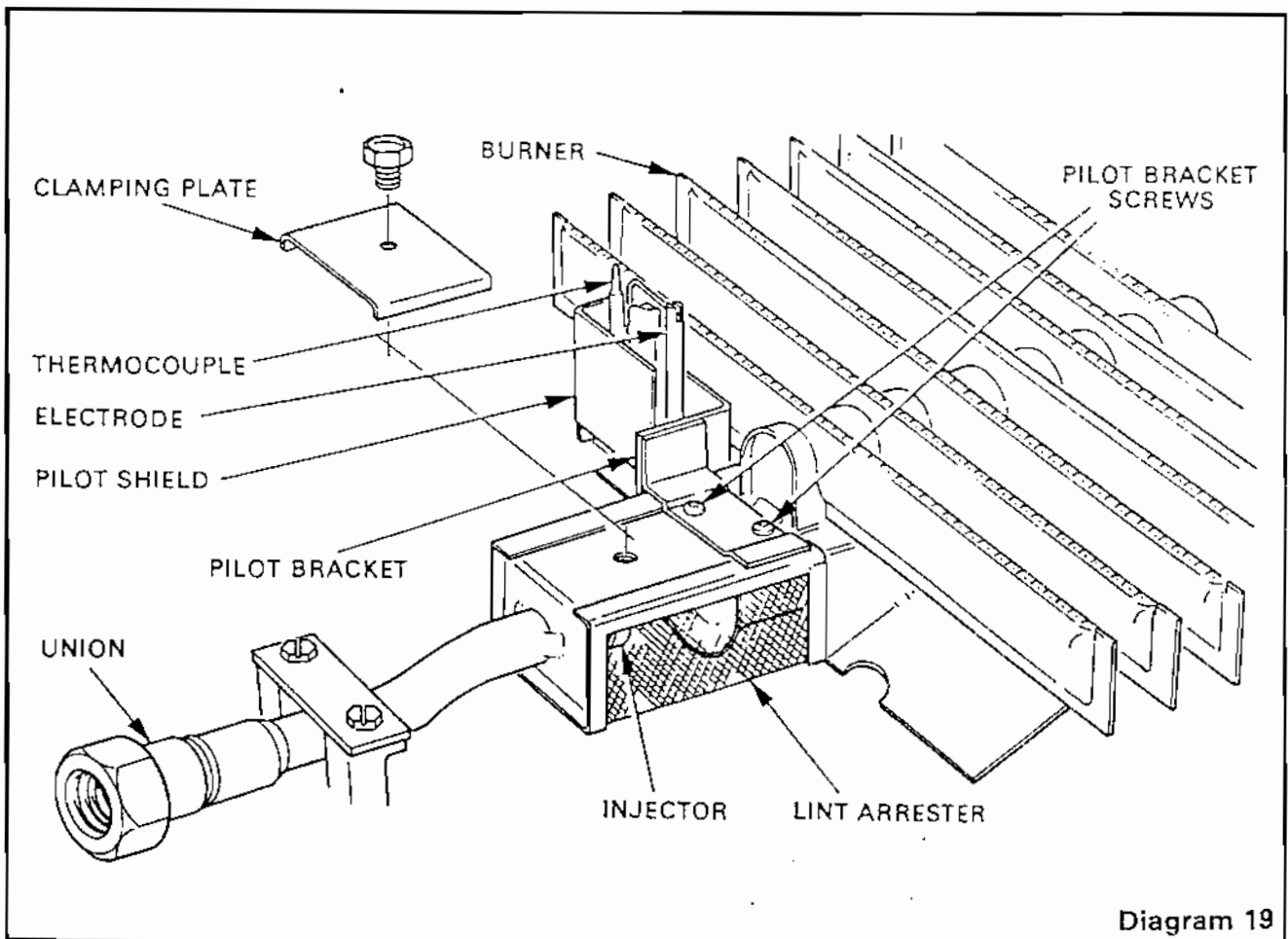
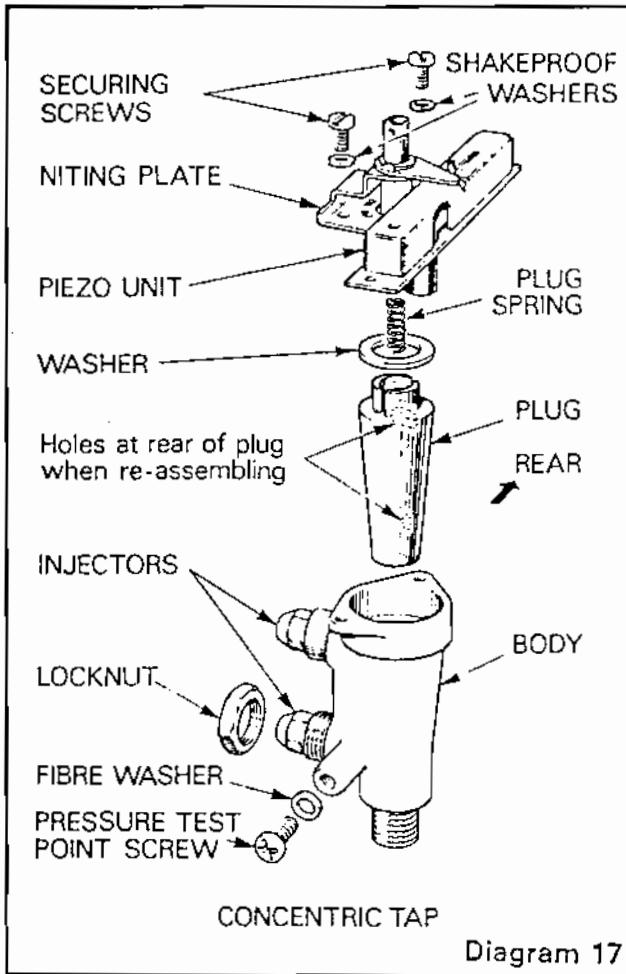

7.3 BOILER BURNER

With the boiler burner and gas valve assembly removed as under "Boiler Flueways" above, clean all accumulated lint and dust from around the burner, pilot burner, lint arrester and controls. Use a vacuum cleaner to avoid brushing the dust etc. into the holes on the burner top.

Remove the lint arrester from the burner assembly by unscrewing the retaining screw and clamping plate, see diagram 19 and sliding the lint arrester forward from the burner. Thoroughly clean the lint arrester and around the injector. Replace the lint arrester by sliding on to the burner and secure with the clamping plate and screw.

7.4 FIRE BURNER

Clean all accumulated lint and dust from the fire burner using a vacuum cleaner. Also clean around the fire chassis.

7.5 DUPLEX GAS TAP

7.5.1 Remove the split pin securing the connecting rod to the gas tap, noting the position of the flat at the top of the rod.

7.5.2 Disconnect the ignition lead at the piezo unit.

7.5.3 With the tap in the 'OFF' position, remove the two screws and washers securing the niting plate and lift off the niting plate. Remove the spring and washer, see diagram 17.

7.5.4 Remove the plug, clean and lightly re-grease.

7.5.5 To re-assemble, insert the plug with the holes in the plug to the rear of the fire.

7.5.6 Refit the spring and washer, and with the spindle in the 'OFF' position replace the niting plate and secure with the two screws and washers. Ensure that the spindle engages with the slots in the plug.

7.5.7 Refit the connecting rod through the rear of the two holes in the top panel. Fit the split pin making sure that the flat on the connecting rod is facing left. Refit the casing and control knob.

8 MAINTENANCE -- REPLACEMENT OF PARTS

8 REPLACEMENT OF PARTS

Before removing or replacing any parts, make sure that the appliance is isolated from the electricity supply and the gas supply is turned off at service tap (See diagram 9).

8.1 GAS FIRE IGNITION ELECTRODE

With the gas fire casing removed as described in Maintenance Instructions 7.2 Boiler Flueways, the gas fire ignition electrode can be removed after disconnecting the lead at the fire electrode and removing the screw securing the electrode to the fire burner, (see diagram 15). When replacing the electrode ensure that the spark gap between electrode tip and burner tip is 3.5mm to 4mm.

8.2 FIRE BURNER

First remove the plinth and outer casing as described in Maintenance Instructions 7.2 Boiler Flueways. Disconnect the ignition lead at the fire electrode (See diagram 15). Unscrew the pan head screw securing the silencer and remove the silencer. Remove the split pin securing the control knob connecting rod to the gas tap spindle and withdraw the rod, noting the position of the flat at the top of the rod. Loosen the gas fire supply pipe tubing nut on the left hand side, (See diagram 14) but do not remove. Unscrew the 19mm A/F locknut from the lower injector boss on the gas tap. Supporting the burner, unscrew the two Pozidriv pan head screws, one at each end of the burner at the side of the fire heat exchanger. When removing the two screws securing the burner, note that these screws also secure an end shield on the left and a flame reversal baffle on the right, (see diagram 15). Ensure that these parts are fitted in the same positions as removed and immediately under the screw heads. Allow the gas tap and pipe assembly to rest on the electrical control box, and remove the burner by moving to the left and forward, taking care not to damage the spark electrode. Refit in reverse order to that described ensuring that the connecting rod is fitted through the rear of the two holes in the top panel. Re-fit the split pin making sure that the flat on the connecting rod is facing left. The two holes in the tap spindle for the split pin should be in line front to rear of the fire, indicating that the tap is in the 'OFF' position. Ensure that the tubing nut is re-tightened when gas tap and burner are secured.

8.3 FIRE INJECTORS

With the fire burner removed as previously described the injectors can be removed from the gas tap. When replacing the injectors a thread sealing compound must not be used, but care should be taken to ensure that the injectors are tightened sufficiently to provide a gas tight seal. (See diagram 15).

8.4 DUPLEX GAS TAP

To remove the gas tap proceed as in 8.2 above but unscrew the tubing nut and ease out the gas supply tube. Remove the gas tap and control assembly. When relacing make sure that the gas tap is in the 'OFF' position, i.e.
....

when the two holes in the gas tap spindle for the split pin are in line front to rear of the fire.

8.5 GAS VALVE

First remove the gas fire as described in 'Maintenance Instructions' under 7.2 'Boiler Flueways'. Make sure the gas service tap is in the 'OFF' position (See diagram 9). Disconnect the pilot supply pipe union and ease out connection. Disconnect thermocouple union 'K'. Disconnect the electrical wiring to the gas valve. Unscrew and disconnect the union at service tap 'Q', and the union elbow at the right hand side of the gas valve. The valve can now be removed and replaced. Re-fit the service tap and union elbow fittings to the replacement valve. Remove the pressure test nipple elbow from the original valve and re-fit in a similar position on the replacement valve. When re-assembling ensure that all joints are re-made gas tight, and that thermocouple union 'K' is not tightened more than one quarter turn beyond finger tight. It will be found necessary to purge the system of air after this operation, and re-lighting should be carried out in accordance with the initial lighting procedure (See section 4.1).

8.6 THERMOCOUPLE

First remove the plinth, casing, fire heat exchanger assembly and combustion chamber front cover assembly as described in Maintenance Instructions 7.2 Boiler Flueways.

Remove the screw securing the pilot shield, (see diagram 19) and the clip securing the thermocouple to the pilot burner. Remove the buckle clip securing the thermocouple to the pilot tube and disconnect pilot tube at the gas valve.

Unscrew the two pilot bracket securing screws to enable the pilot assembly to be fitted). Unscrew the thermocouple union 'K' on the gas valve, and remove the thermocouple completely. Replace taking care not to tighten thermocouple union 'K' more than one quarter turn beyond finger tight.

8.7 BOILER BURNER

First remove the plinth, casing, fire heat exchanger assembly and combustion chamber front cover assembly as described in Maintenance Instructions 7.2 Boiler Flueways.

Remove the two screws securing the pilot bracket and unscrew the union nut at the gas inlet to the burner, see diagram 19. The burner will then be free. Transfer the union connection from the old burner to the replacement, using a little sealant on the threads.

CARE MUST BE TAKEN WHEN REMOVING AND REPLACING BURNER.

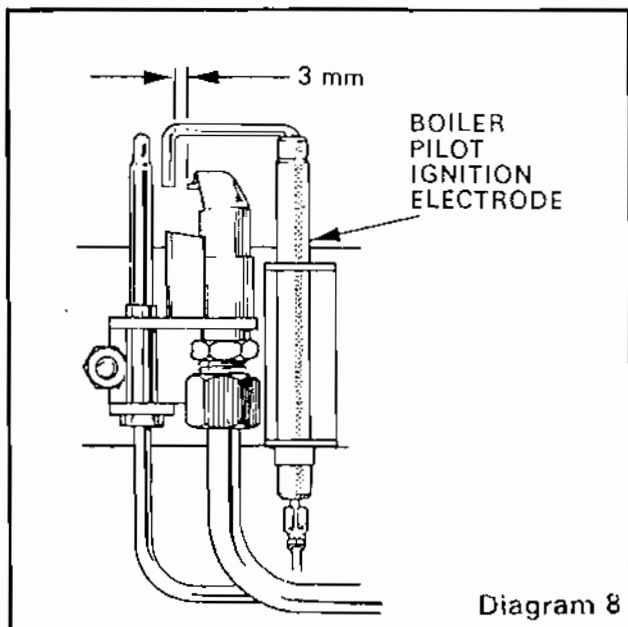

8.8 BOILER ELECTRODE

First remove the plinth, casing, fire heat exchanger assembly and combustion chamber front cover assembly as described in Maintenance Instructions 7.2 Boiler Flueways.

With the boiler burner and gas control assembly removed, remove the screw securing the pilot shield, see diagram 19. Unscrew the pilot tube union at the gas valve, remove the two Pozidriv Taptite screws securing the pilot bracket to the burner and unscrew the hex. nut from the stud securing the electrode to the pilot bracket. Pull the ignition lead from the tag connection on the electrode. When re-fitting the electrode, replace the nut on the lower stud and ensure that the spark gap is as shown in diagram 8.

8.9 BOILER PILOT BURNER

First remove the plinth, casing, fire heat exchanger assembly and combustion chamber front cover assembly as described in Maintenance Instructions 7.2 Boiler Flueways. Remove the pilot shield, gas valve pilot union and pilot bracket screws as in 8.8 Boiler electrode, remove the clip securing the thermocouple to the pilot burner and withdraw the thermocouple. Unscrew the hex. nut from the stud securing the electrode to the pilot bracket and the screw and nut securing the pilot burner. Disconnect the pilot tube at the base of the pilot burner by using two spanners, one on the union and the other on the hexagon immediately above the union nut and thread. When re-fitting, secure electrode by the lower stud and ensure that the spark gap is as shown in diagram 8.

8.10 BOILER INJECTOR

First remove the plinth, casing, fire heat exchanger assembly and combustion chamber front cover assembly as described in Maintenance Instructions 7.2 Boiler Flueways.

Remove the lint arrester from the burner assembly by unscrewing the retaining screw and removing the clamping plate, see diagram 19.

Slide the lint arrester forward from the burner. Unscrew the injector and replace using a little sealing compound on the threads.

8.11 ELECTRICAL CONTROL BOX

Remove the plinth, casing and the fire heat exchanger and rear panel assembly as described in Maintenance Instructions. Pull the thermostat control knob forwards off its spindle and disconnect the spark ignition lead at the piezo unit. Remove the two Pozidriv pan head screws and shakeproof washers securing the cover to the control box body and remove the cover. Disconnect all external leads at the terminal strip, slackening off the screw securing the mains cable clip to enable the mains cable to be withdrawn. Release the thermostat capillary from its clip on the fire support plate, (see diagram 12). This is only necessary when the thermostat phial is fitted into the left-hand side of the boiler. Remove the phial from its pocket. The control box is secured to a bracket with two M5 Pozidriv screws and hex. nuts. Remove these and the control box may then be withdrawn. Replace in the reverse order. For details of the wiring see relevant wiring diagrams under 'Installation'.

NOTE: When re-fitting the thermostat phial, ensure that it is inserted fully into its pocket and retained with the fix provided. If the phial pocket is fitted on the left-hand side of the boiler, secure the capillary in the clip as shown in diagram 12.

8.12 BOILER PIEZO UNIT

Remove the plinth, casing and the fire heat exchanger and rear panel assembly as described in Maintenance Instructions, 7.2 : Boiler Flueways. Remove the boiler thermostat knob and control box cover as described in 8.11 Electrical Control Box, above. The piezo unit can then be removed as necessary. Replace in the reverse order.

8.13 FIRE PIEZO UNIT/NITING PLATE ASSEMBLY

Remove the plinth and casing as described in Maintenance Instructions, 7.2 : Boiler Flueways and remove the piezo unit and niting plate assembly as described in Maintenance Instructions : Duplex Gas Tap 7.5.1, 7.5.2 and 7.5.3. Replace in reverse order as described in 7.5.5, 7.5.6 and 7.5.7.

9 FAULT FINDING – BOILER

9 FAULT FINDING CHART

9.2 PILOT WILL NOT LIGHT

Cause	Remedy
9.2.1 Air in gas line	Purge out air.
9.2.2 Gas supply to pilot restricted: (Check by applying match to pilot instead of pressing igniter).	Rectify blockage in multi-function control. Ensure pilot throttle is fully open.
(a) On undoing the tubing nut at pilot multi-functional control and pressing knob, gas does not flow freely.	Change blocked pilot tube.
(b) On undoing tubing nut at burner and pressing control knob, gas does not flow freely.	Rectify blockage in pilot injector or pilot head.
(c) As 9.2.2 (b) but gas does flow freely.	Pull ignition lead off electrode. Hold end of lead close to burner, and operate piezo unit. If no spark, change ignition lead and/or piezo unit.
9.2.3 No spark.	Re-position electrode as shown in diagram 8.
9.2.4 Electrode not correctly positioned in relation to pilot head.	
9.3 PILOT WILL NOT STAY ALIGHT WHEN CONTROL KNOB IS RELEASED.	

Cause	Remedy
9.3.1 Pilot flame not impinging on thermocouple.	Check pilot injector or pilot gas adjustment.

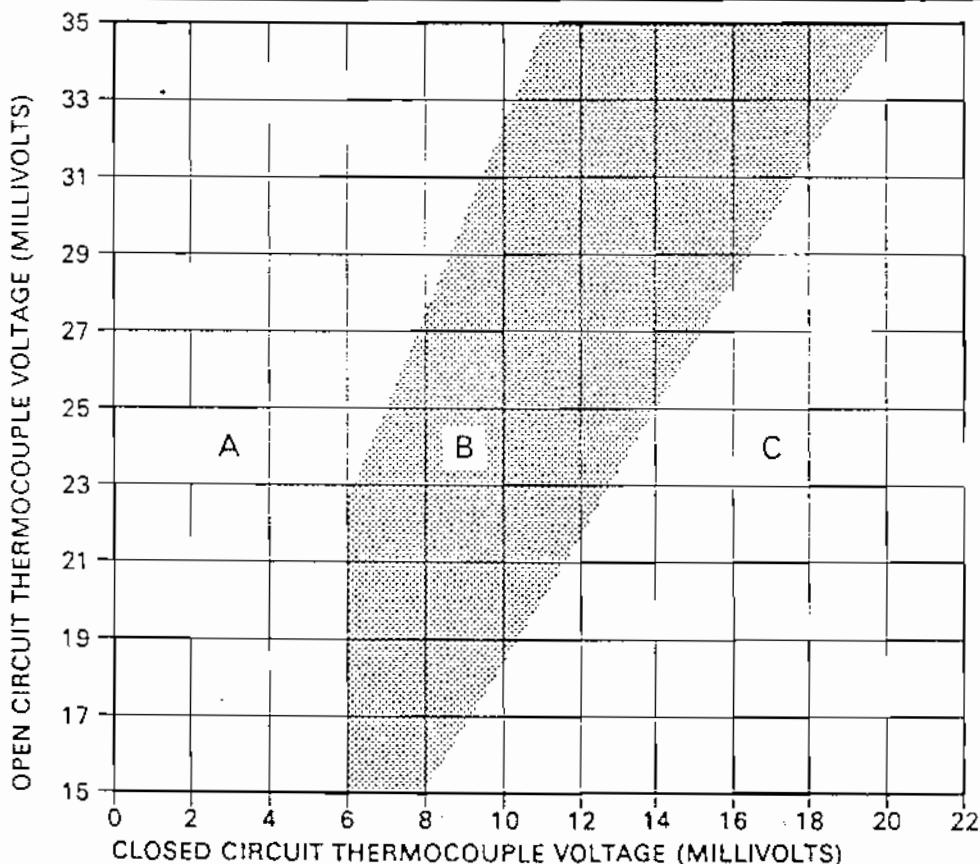

DIAGNOSIS GRAPH FOR THERMOCOUPLE CIRCUIT

Diagram 20

9.3.2 To test the thermocouple, a meter with a range of 0 - 30 mV is required, together with a thermocouple interrupter test unit similar to the B.G.C. (Minitest 6) Multimeter and interrupter.

Refer to Thermocouple diagnosis graph (diagram 20) when using this chart.

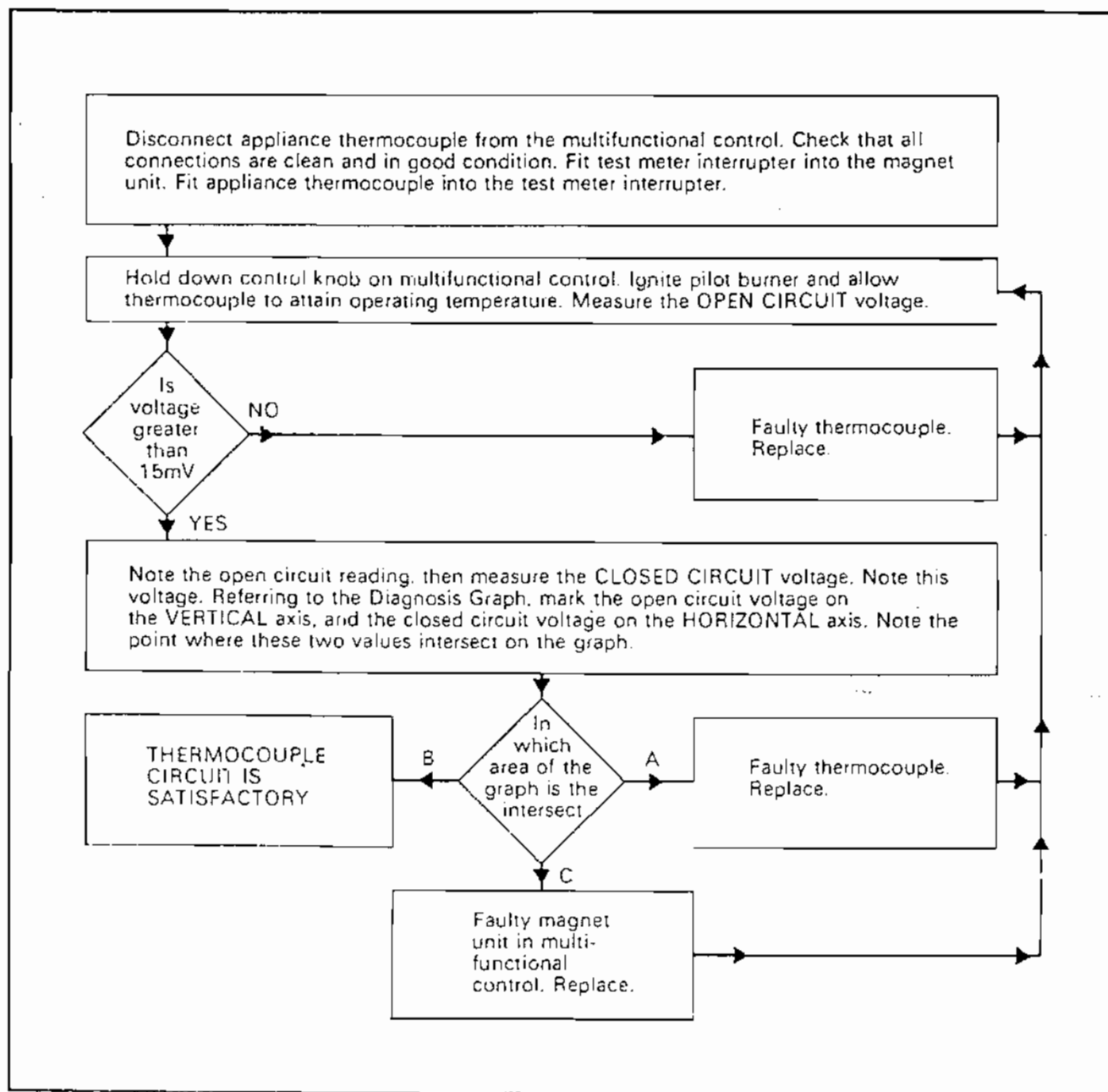

9 FAULT FINDING — BOILER

9.4 ELECTRICAL FAULT FINDING. Refer to wiring diagram when using this chart (diagram 21).

9.5 IMPORTANT: The preliminary electrical system checks as contained in the British Gas Multimeter instructions book are the first

checks to be carried out during a fault-finding procedure. On completion of the service fault-finding task which has required the breaking and re-making of electrical connections then the checks 'A' Earth continuity, 'C' Polarity and 'D' Resistance to Earth must be repeated.

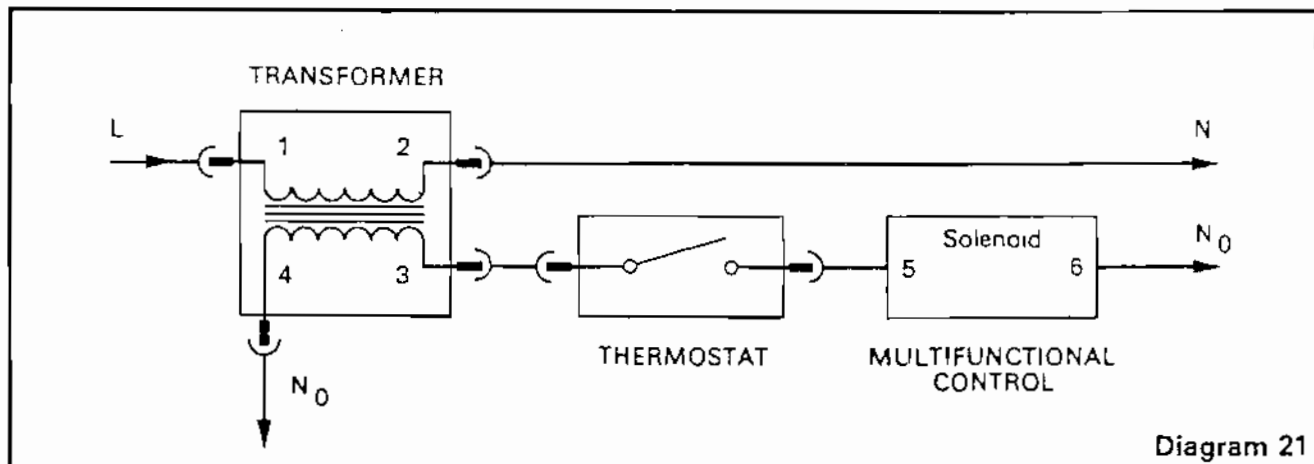
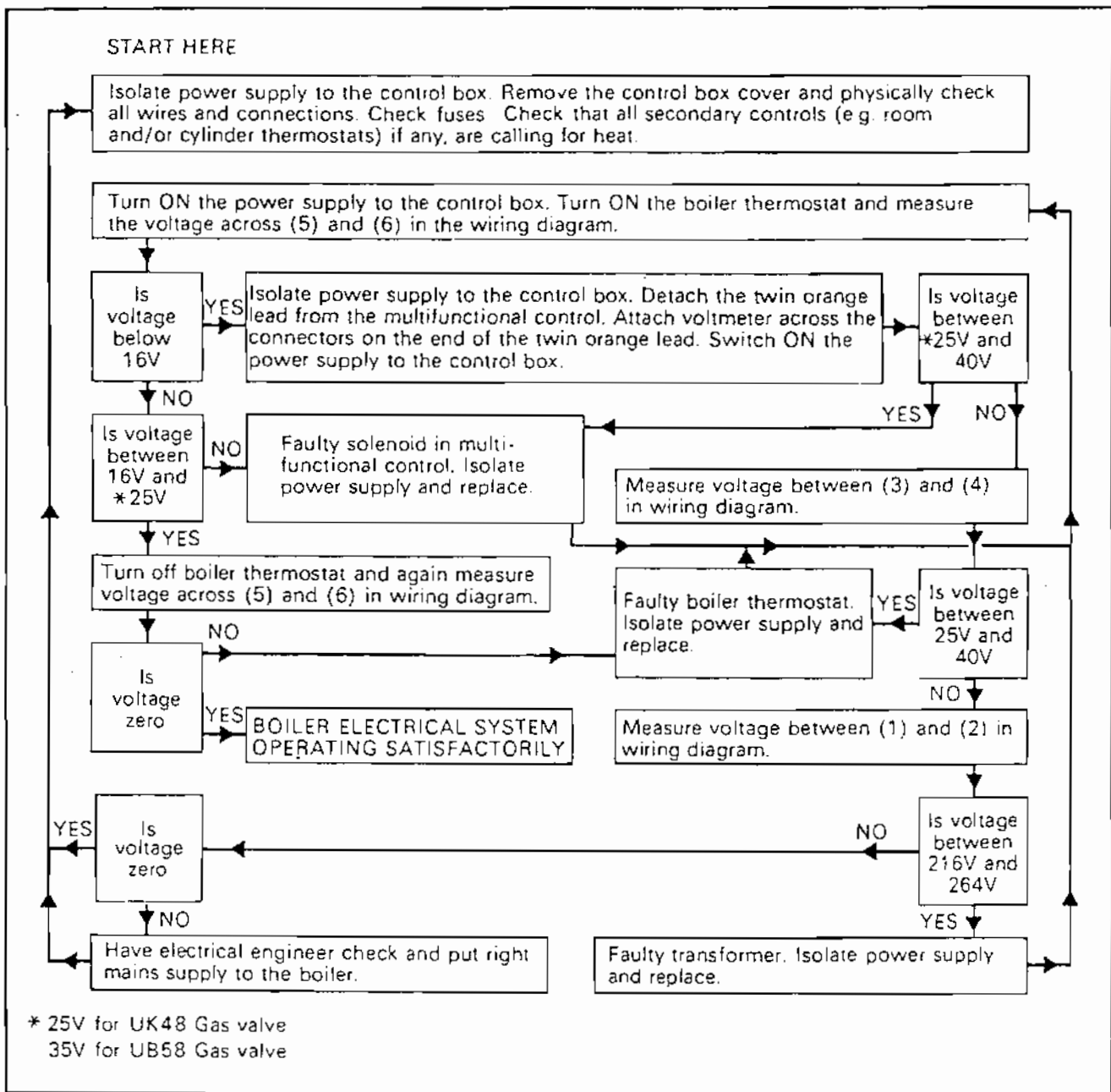

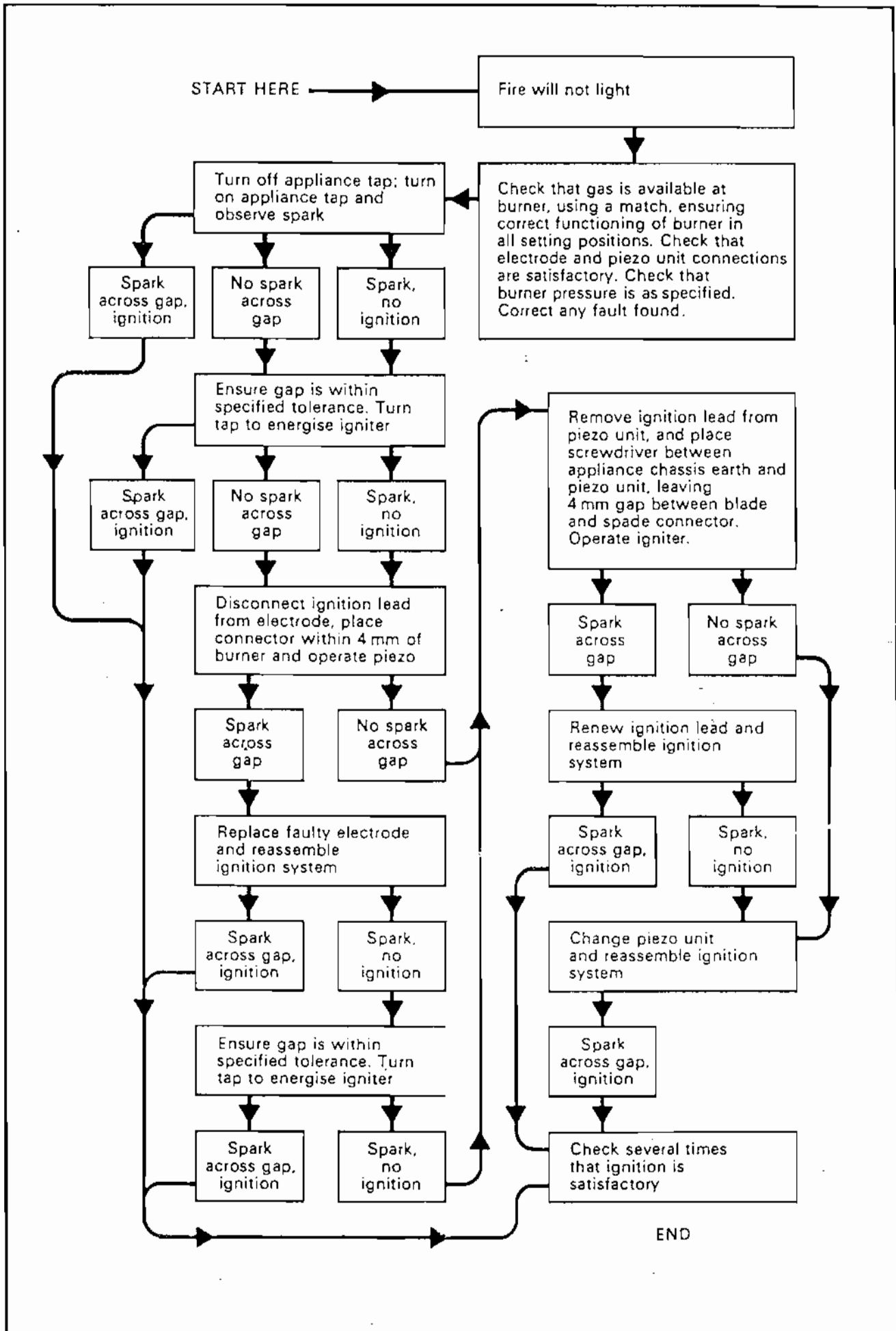

10 REPLACEMENT PARTS

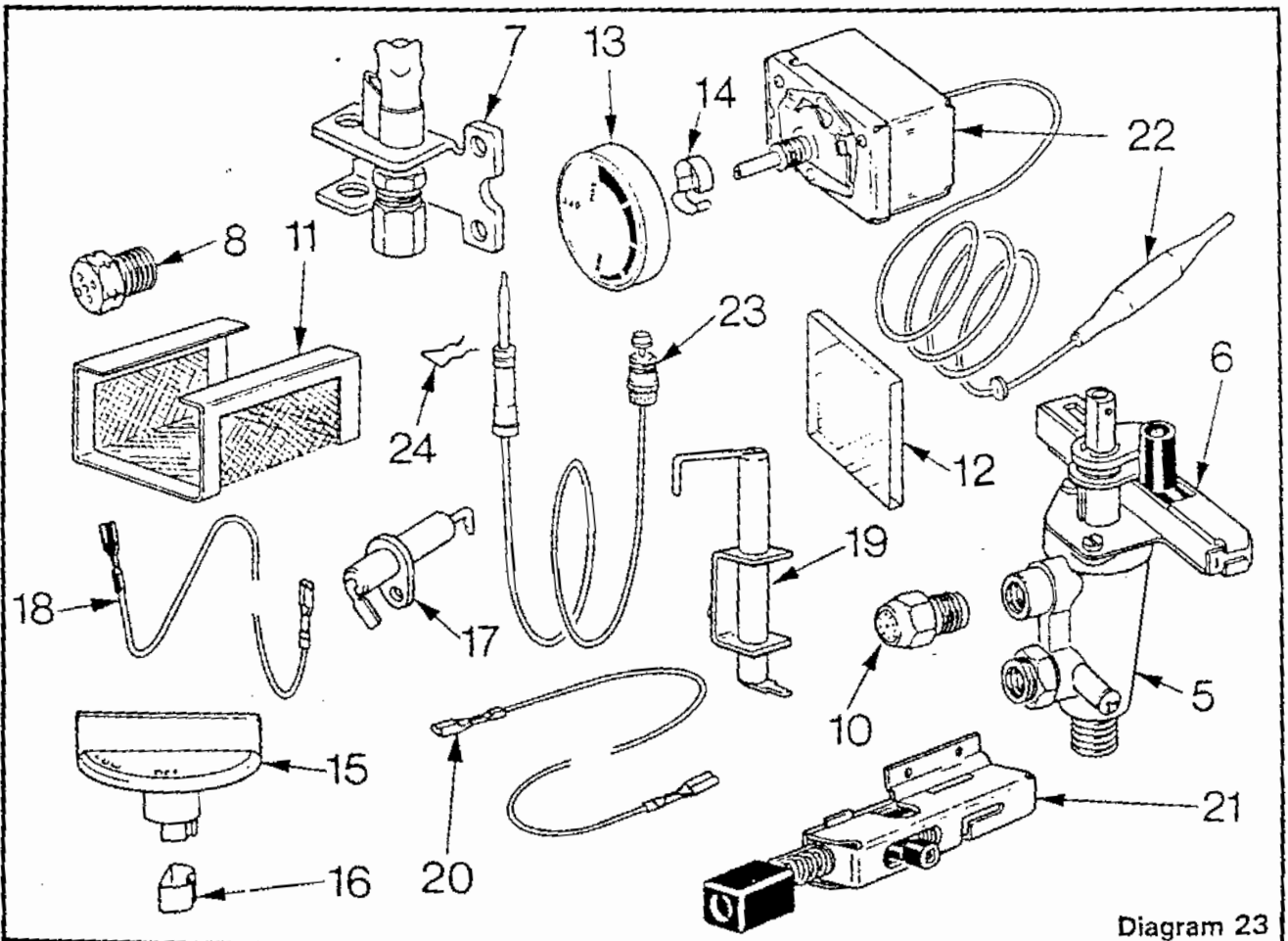
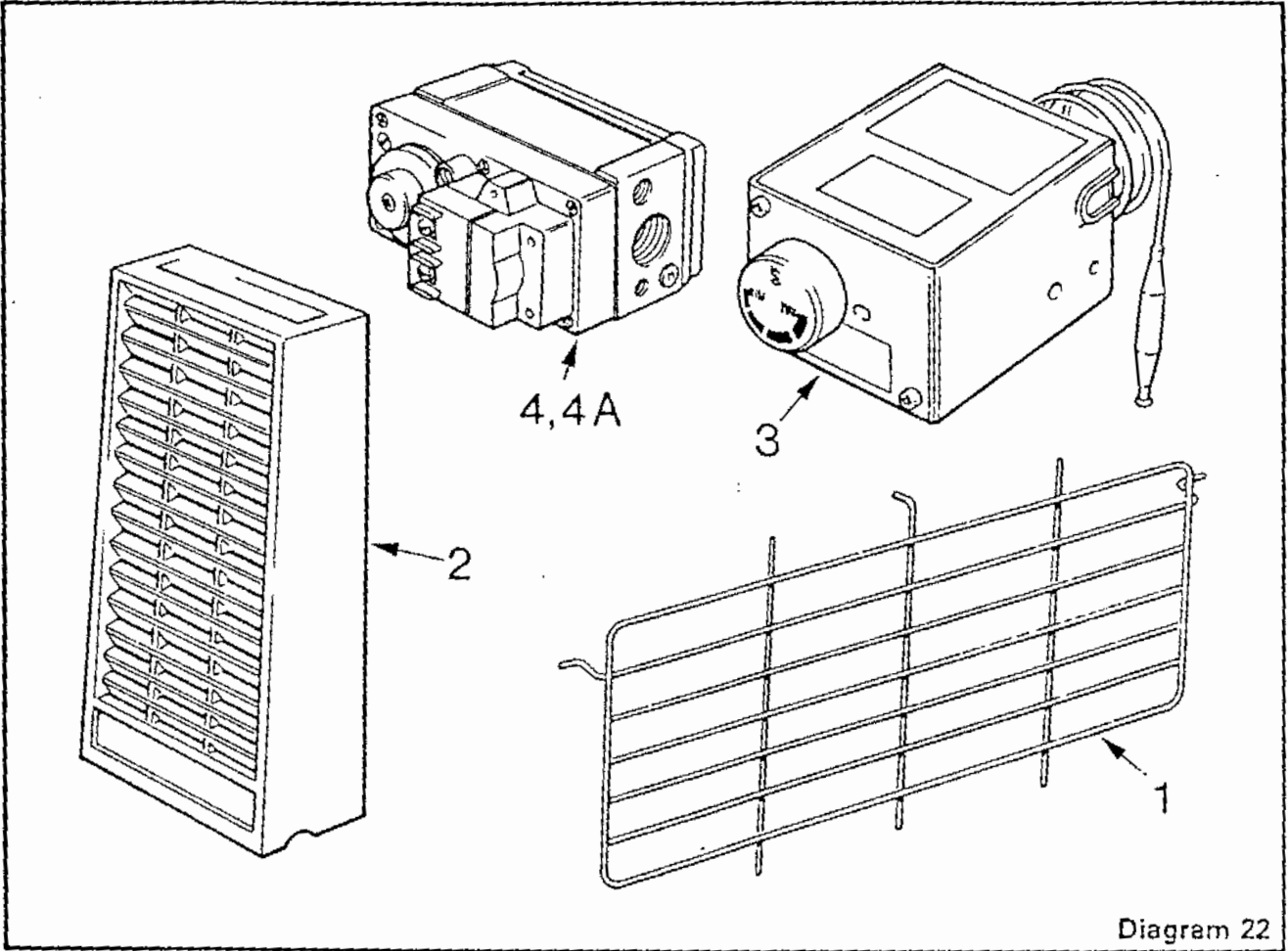

REPLACEMENT PARTS 10

Item No.	G.C. Part No.	Description	Glow-worm Part No.
1	152 405	Dressguard	K6223
2	152 442	Radiant	K6936
3	191 232	Electrical control box	FF1210
4	392 767	1/2 in. BSP Midgitrol gas valve, Maclaren UK 48RBB 05	K9049
4A	383 540	1/2 in. BSP Midgitrol gas valve, Maclaren UB 58RAB 29	FF2109
5	387 696	Gas tap-fire c/w Piezo unit, Concentric JC/A/638	K7344
6	388 062	Piezo unit fire, Concentric JC/SA/1260 (for item 5 only)	K8059
7	391 535	Pilot burner c/w straight adaptor, Maclaren 26T0166 TL016	K8356
8	384 673	Injector-boiler Furigas 015.015.000	K9207
10	398 349	Injector-fire Bray Cat. 28 No. 200	K6463
11	384 669	Lint arrester, Furigas 018.014.000	K9210
12	351 661	Sight glass	K5226
13	191 229	Control knob - boiler thermostat	FF2224
14	396 216	Clip-control knob, Lewis spring LS/402/17	K4158
15	152 443	Control knob - fire	K6946
16	152 554	Clip-control knob, KC 1/4/0148/BD35	K8548
17		Electrode-fire, Buccleuch BE/3163/S1	415062
18		Ignition lead - fire	WW4609
19	393 713	Electrode - boiler, Kigass E6645	K9206
20	135 945	Ignition lead - boiler	WW4604
21	397 907	Piezo unit - boiler, Kigass D5037	K6587
21	393 563	Piezo unit - boiler, Vernitron Variant 66108	K6587
22	382 388	Thermostat - boiler, Ranco C26 - PO641	FF2129
23	390 929	Thermocouple, Maclaren 2500M-24	K4860
24	390 983	Clip - Thermocouple	K3580

If replacement parts are required, apply to your local supplier. Please quote the name of the appliance "Glow-worm Capricorn 240/6" and preferably serial numbers which can be found on the data badges positioned in the lower L.H. of the fire back panel and on the side of the boiler control box.

Because of our constant endeavour for improvement, details may vary slightly from those in this booklet.



TI Glow-worm Ltd
A member of the TI Group



Nottingham Road, Belper, Derby DE5 1JT
Telephone Belper 4141 Telex 37586
Service Engineer Enquiries only Belper 6516