

Wall hung, fan flue, room sealed gas boiler

SERVICE MANUAL

Models: G.C. Appl. No.

24S 47 970 06

28S 47 970 07

24SR 41 970 03

Leave this manual adjacent to the gas meter

Biasi U.K. Ltd
Unit 32/33, Planetary Road
Industrial Estate, Neachells Lane
Willenhall, Wolverhampton WV 13 3XB
Tel: 01902 304 400



Table of contents

1 Overall information	1	10 Full sequence ignition device	22
1.1 Overall View	1	10.1 Function	22
1.2 Hydraulic diagram	1	10.2 Checks	22
2 General access and emptying hydr. circuits	2	10.3 Removal	22
2.1 Nomenclature	2	10.4 Ignition sequence	23
2.2 Body panels	2	11 Gas valve	24
2.3 Control panel	2	11.1 Function	24
2.4 Access to the electric parts of the control panel	3	11.2 Nomenclature of the parts	24
2.5 Access to the sealed chamber	3	11.3 Adjustment	24
2.6 Emptying the main circuit	3	11.4 Checks	24
2.7 Emptying the d.h.w. circuit	4	11.5 Removal	25
3 Diagrams	5	12 Main circuit flow switch	26
3.1 Wiring diagram	5	12.1 Function	26
3.2 Functional flow diagrams	6	12.2 Checks	26
3.3 Control circuit voltages	8	12.3 Removal	26
4 Fault finding	9	13 D.h.w. filter and flow limiter	28
5 Main heat exchanger	12	13.1 General notes	28
5.1 Characteristics	12	13.2 Removal of the filter	28
5.2 Removal	12	13.3 Flow limiter	28
5.3 Cleaning	12	14 Temperature probes	29
6 D.h.w. heat exchanger	13	14.1 Function	29
6.1 Function	13	14.2 Checks	29
6.2 Removal	13	14.3 Removal	29
7 Pump	14	15 By-pass valve	31
7.1 Function	14	15.1 Function	31
7.2 Checks	14	15.2 Removal	31
7.3 Removal	14	16 Flue fan, venturi, air pressure switch	32
8 Diverter valve and d.h.w. pressure switch	15	16.1 Function	32
8.1 Function	15	16.2 Checks	32
8.2 Checks	15	16.3 Removal of the fan	33
8.3 Removal	15	16.4 Removal of the air pressure switch	33
9 Electronic control circuit	18	17 Ignition and detection electrodes	34
9.1 Function	18	17.1 Function	34
9.2 Selection and adjustment devices	18	17.2 Checks	34
9.3 Checking the temperature	18	17.3 Removal	34
9.4 Function selectors	19	18 Safety thermostat	35
9.5 Ignition gas pressure regulator	20	18.1 Function	35
9.6 Max. c/h power regulator	20	18.2 Checks	35
9.7 Checks	20	18.3 Removal	36
9.8 Removal of the control circuit	20	19 Short spare parts list	38
9.9 Thermal control in the "winter" mode	21		
9.10 Thermal control in the "summer" mode	21		

1 Overall information

1.1 Overall View

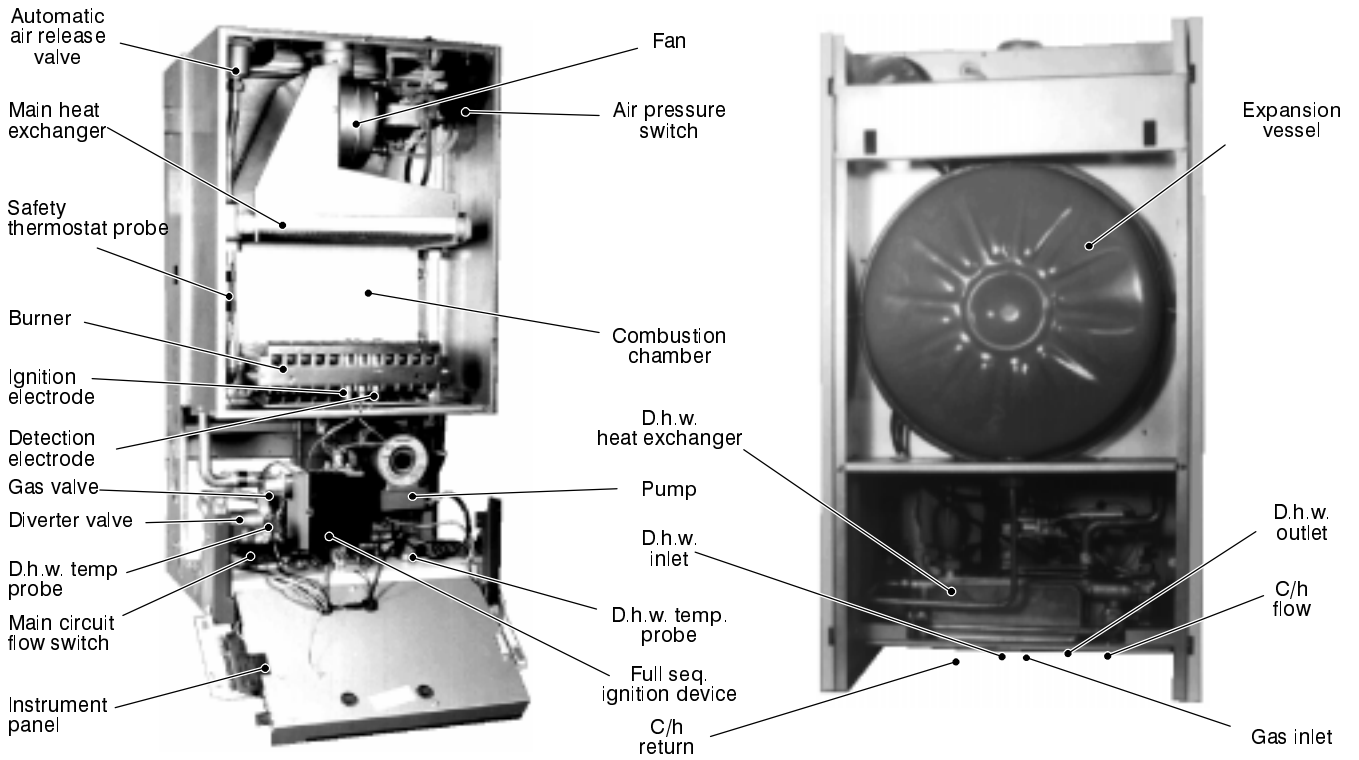

fig. 1

1.2 Hydraulic diagram

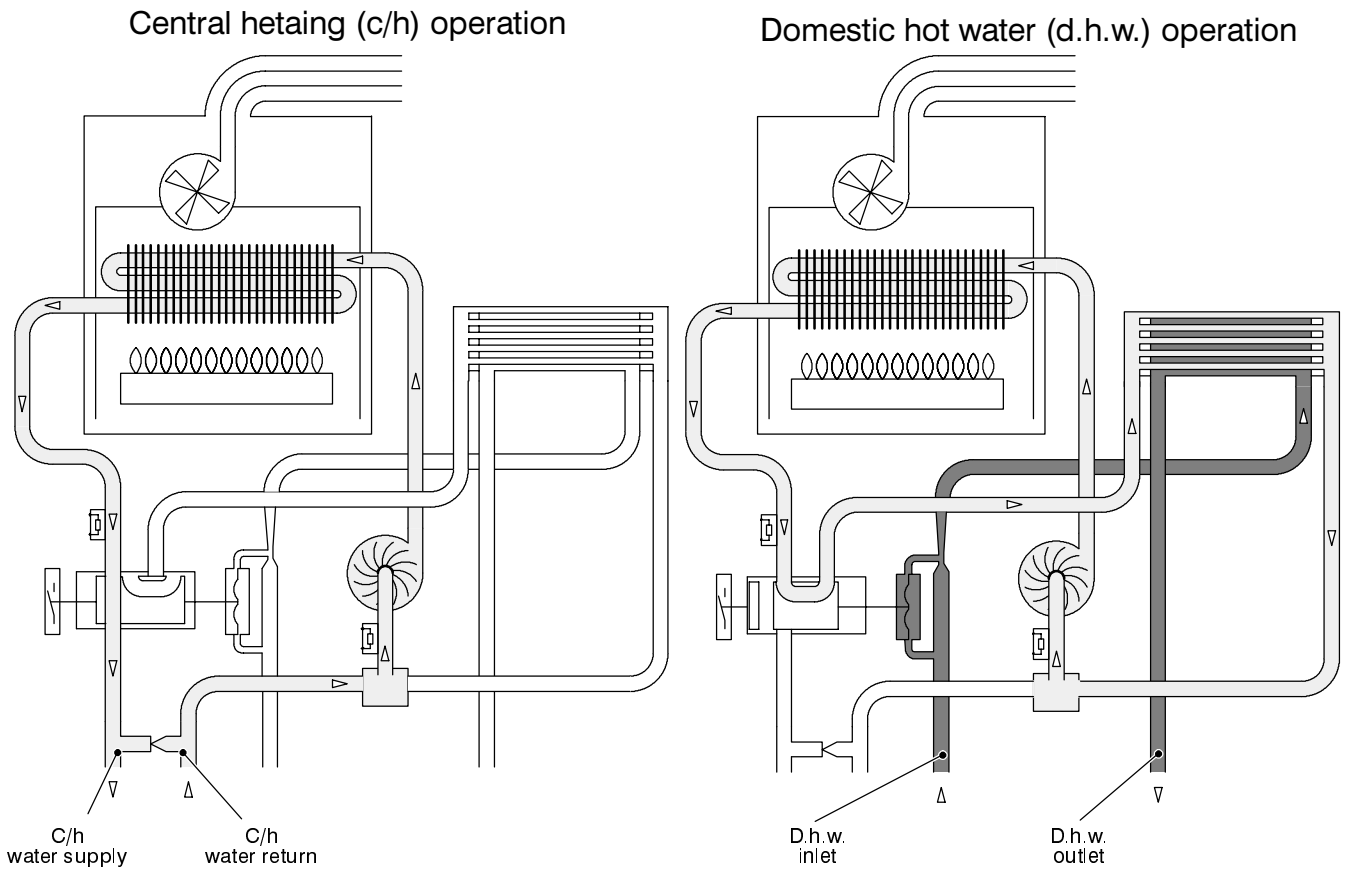

fig. 2

2 General access and emptying hydraulic circuits

2.1 Nomenclature

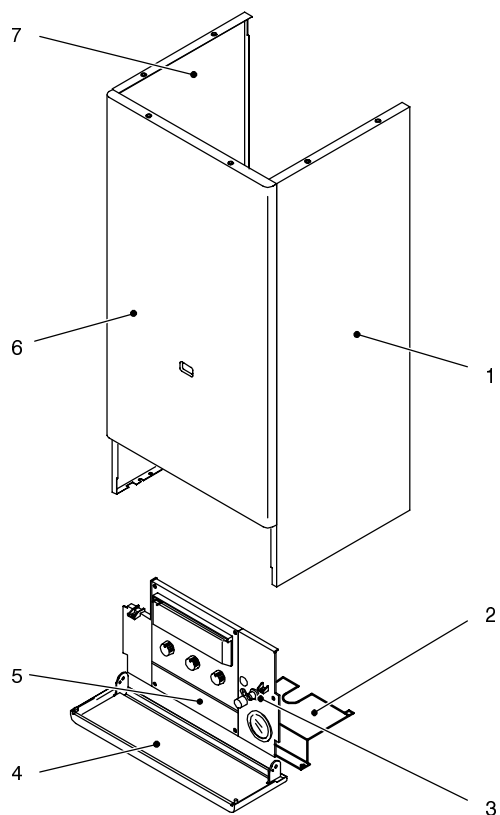

fig. 3

- 1 Right side panel
- 2 Lower protection plate
- 3 Instrument panel
- 4 Control-panel cover
- 5 Service panel
- 6 Front panel
- 7 Left side panel

2.2 Body panels

Warning: isolate the boiler from the mains electricity supply before removing any covering or component.

For the most part of the check and maintenance operations it is necessary to remove one or more panels of the body.

The side panels can be removed only after the removal of the front panel.

To remove the front panel remove screws A (fig. 4), bring the base of the panel far from the boiler and lift it, freeing it from the top hooks.

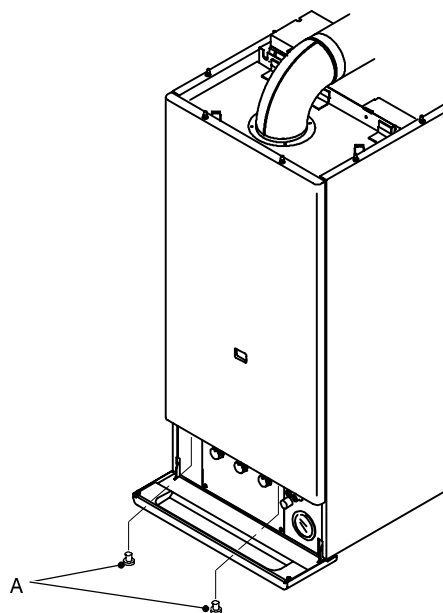

fig. 4

To remove the side panels bring the base of the panels far from the boiler and lift them, freeing them from the side hooks.

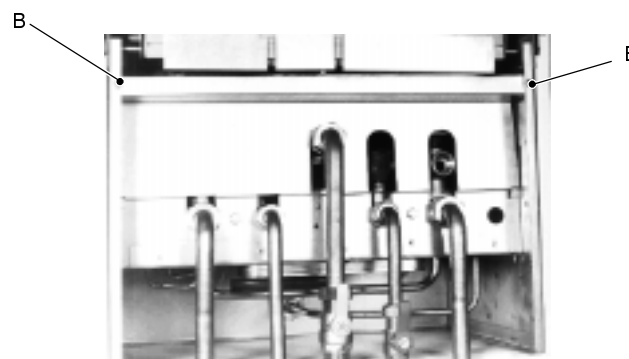

fig. 5

To remove the lower protection loosen the screws B (fig. 5).

2.3 Control panel

To gain access to the parts located behind the instrument panel proceed as follows:

- 1 Remove the front panel of the body
- 2 Remove the two screws C (fig. 6) and lower the instrument panel.

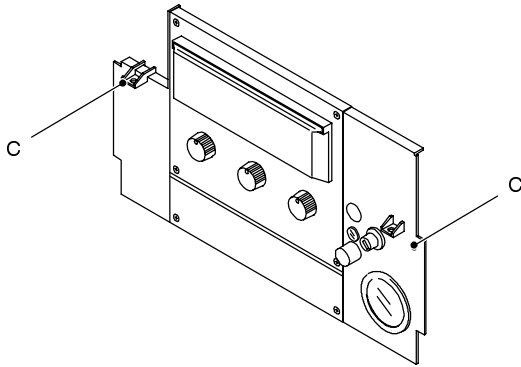

fig. 6

2.4 Access to the electric parts of the control panel

Warning: isolate the boiler from the mains electricity supply before removing any covering or component.

- To remove the service panel "5":

Remove the two screws *D* and remove the service panel (fig. 7);

- To gain access to the electronic regulation PCB

Remove the four screws *E* and remove the controls panel (fig. 7);

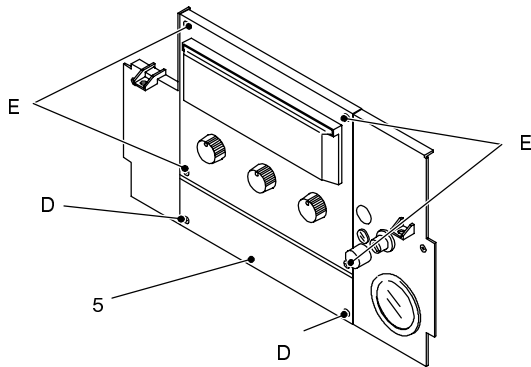

fig. 7

- To gain access to the thermostats and other electric parts (rear side of the panel);
- 1 Remove the front panel of the body and lower the instrument panel.
 - 2 Remove the four screws *F* (fig. 8) and remove the metallic cover.

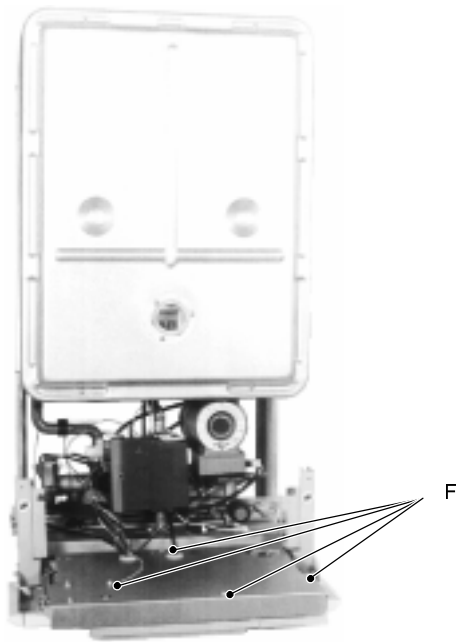

fig. 8

2.5 Access to the sealed chamber

To gain access to the parts contained in the sealed chamber it is necessary to remove the cover of the sealed chamber.

For this purpose, remove the front panel of the body, remove the screws *G* as indicated in fig. 9.

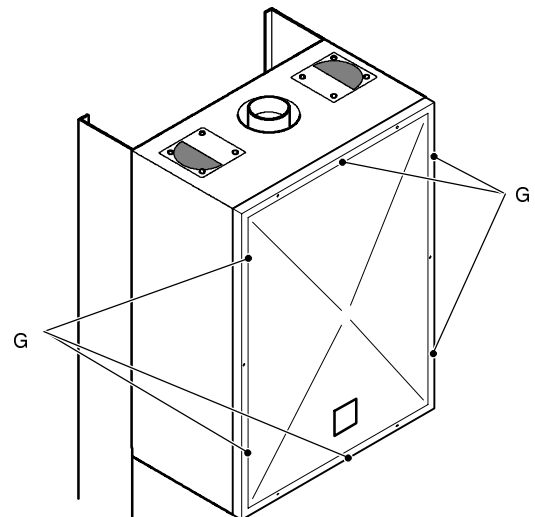

fig. 9

2.6 Emptying the main circuit

- 1 Close the c/h circuit isolation valves.

- 2 Open the draining tap *H* (fig. 10) until the boiler is completely emptied.

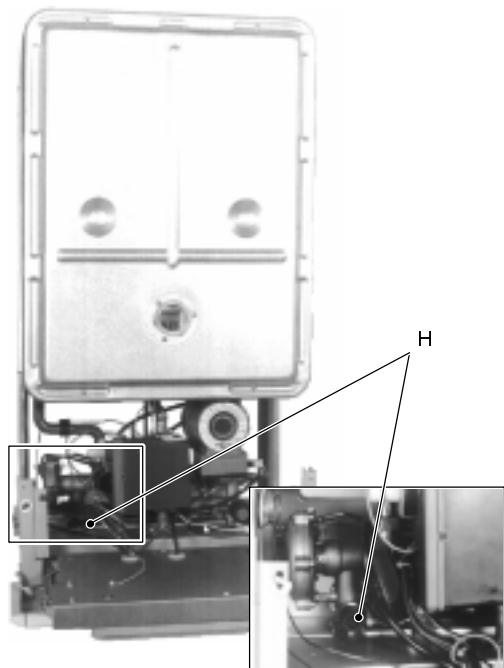

fig. 10

To facilitate the downflow of water, remove the front panel, also remove the sealed chamber lid and loosen the nut *I* (fig. 11) of the automatic air bleed valve. Tight it again once the emptying has been completed.

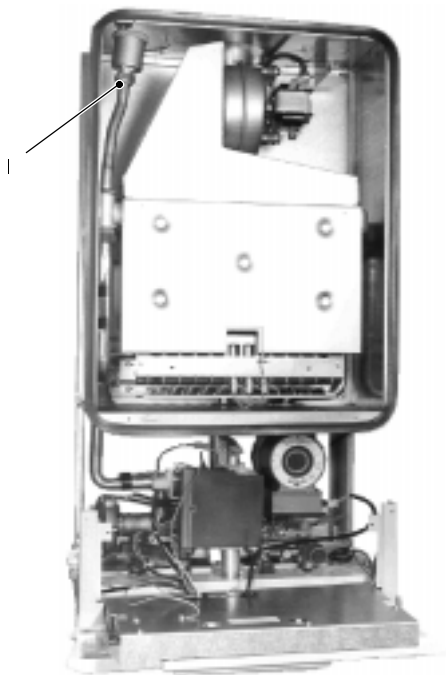

fig. 11

2.7 Emptying the d.h.w. circuit

- 1 Remove the lower protection of the boiler;
- 2 Close the d.h.w. circuit cut-off valve *J* (fig. 12);
- 3 Open one or more hot water taps of the plant until the boiler has been completely emptied.



fig. 12

3 Diagrams

3.1 Wiring diagram

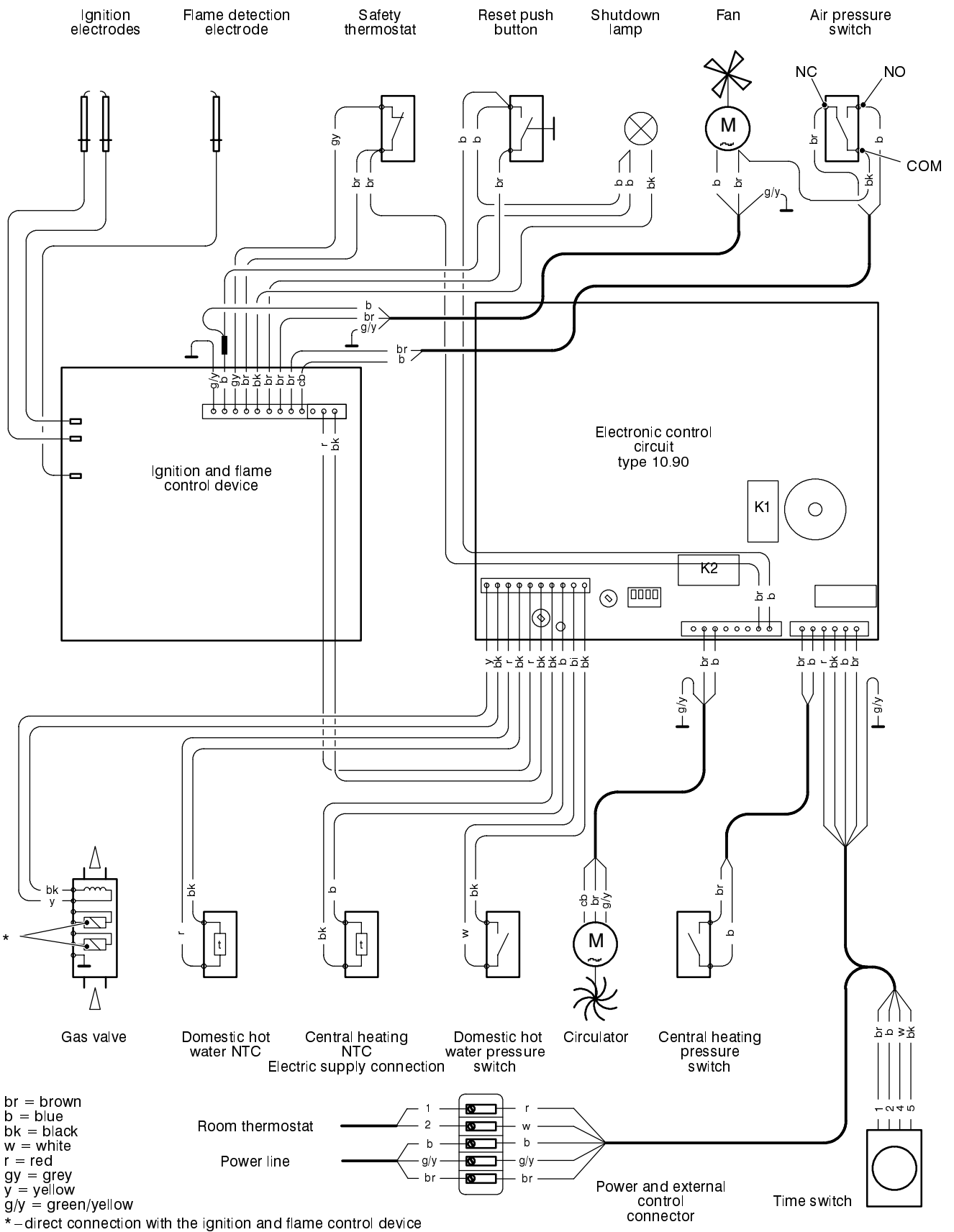

3.2 Functional flow diagrams

General layout
function switch position off

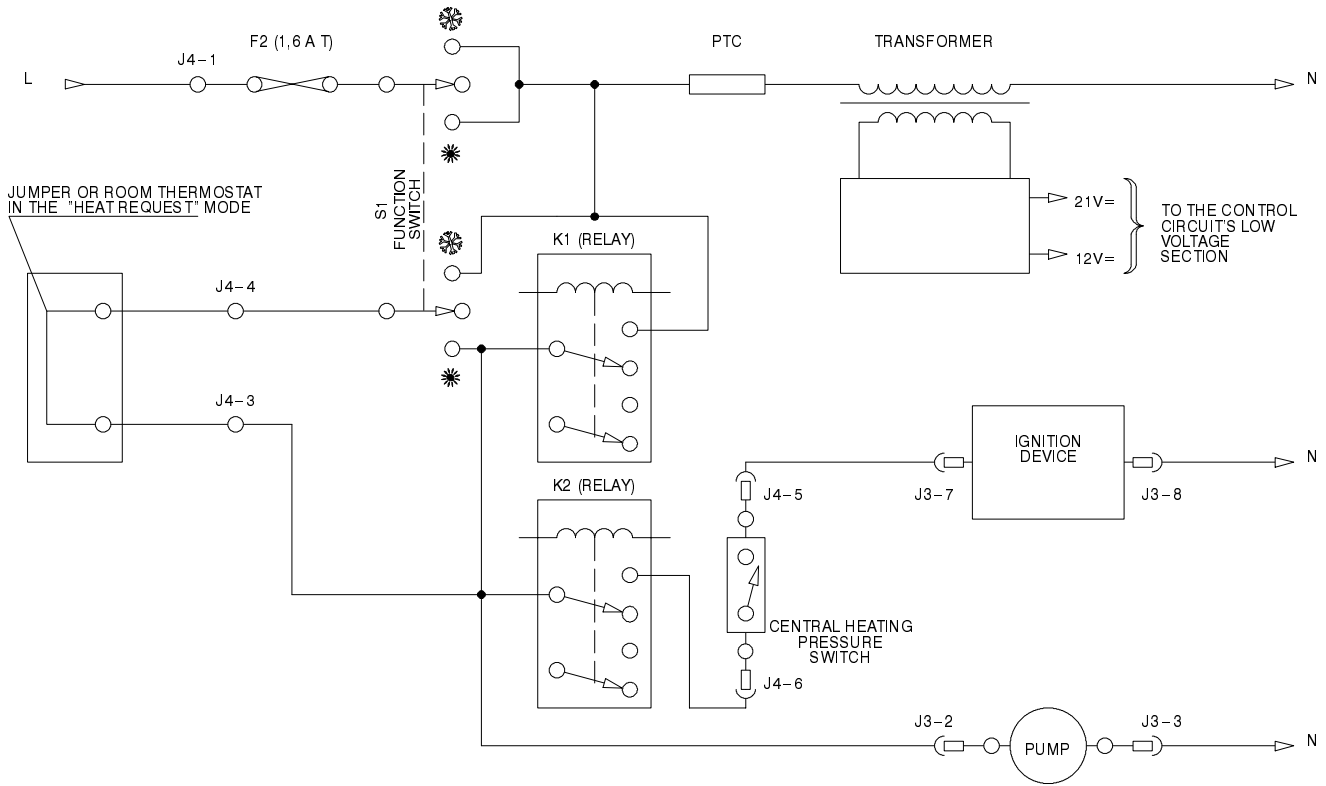
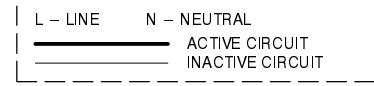

Function switch position Heat request on c/h

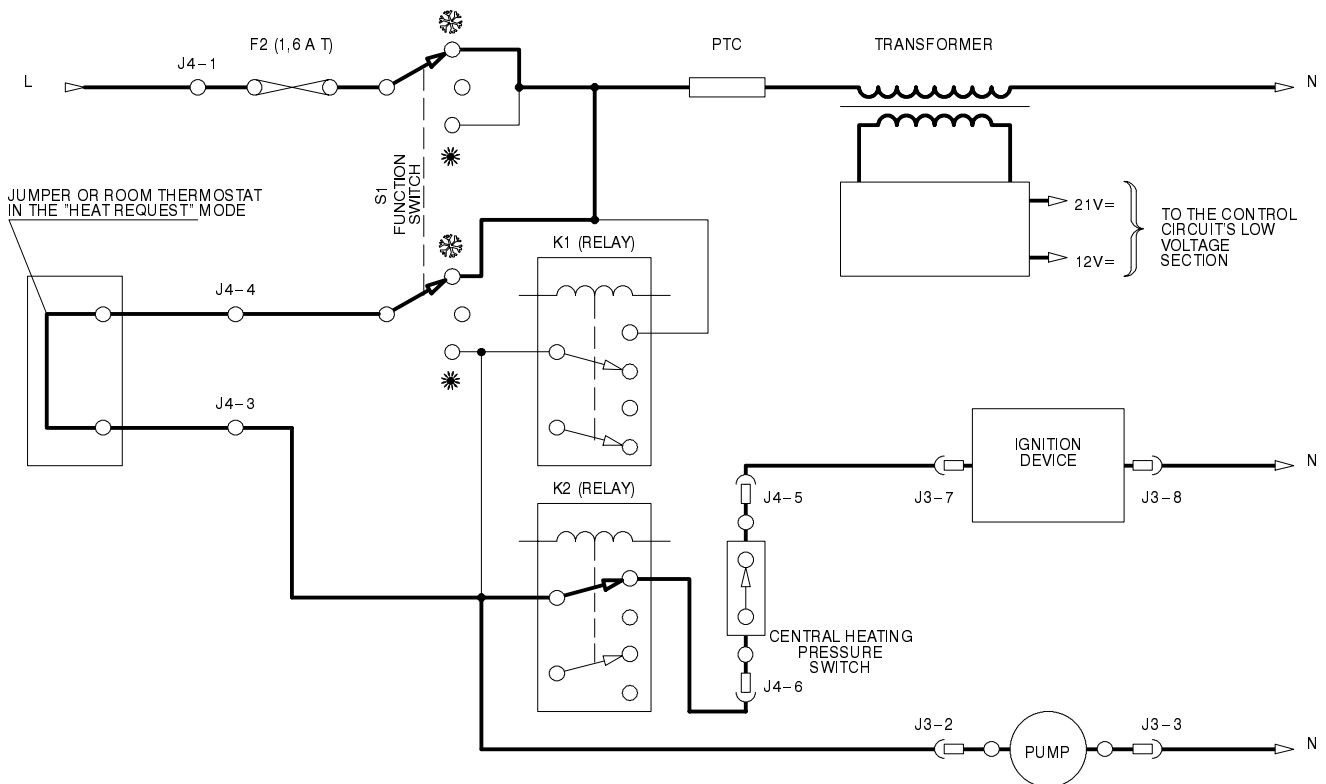

Function switch position ❄️
Heat request on d.h.w.

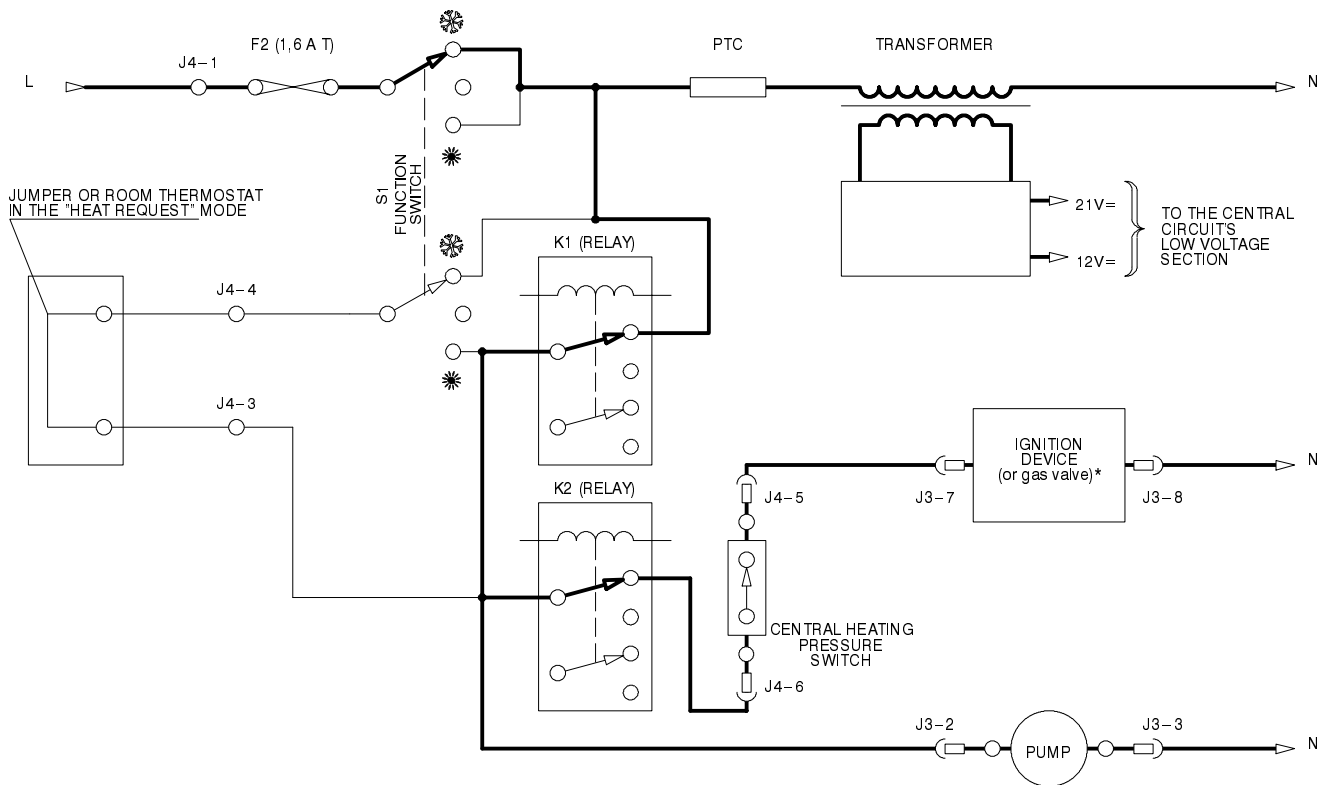
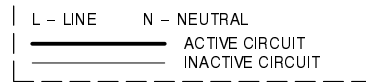

Function switch position *
Heat request on d.h.w.

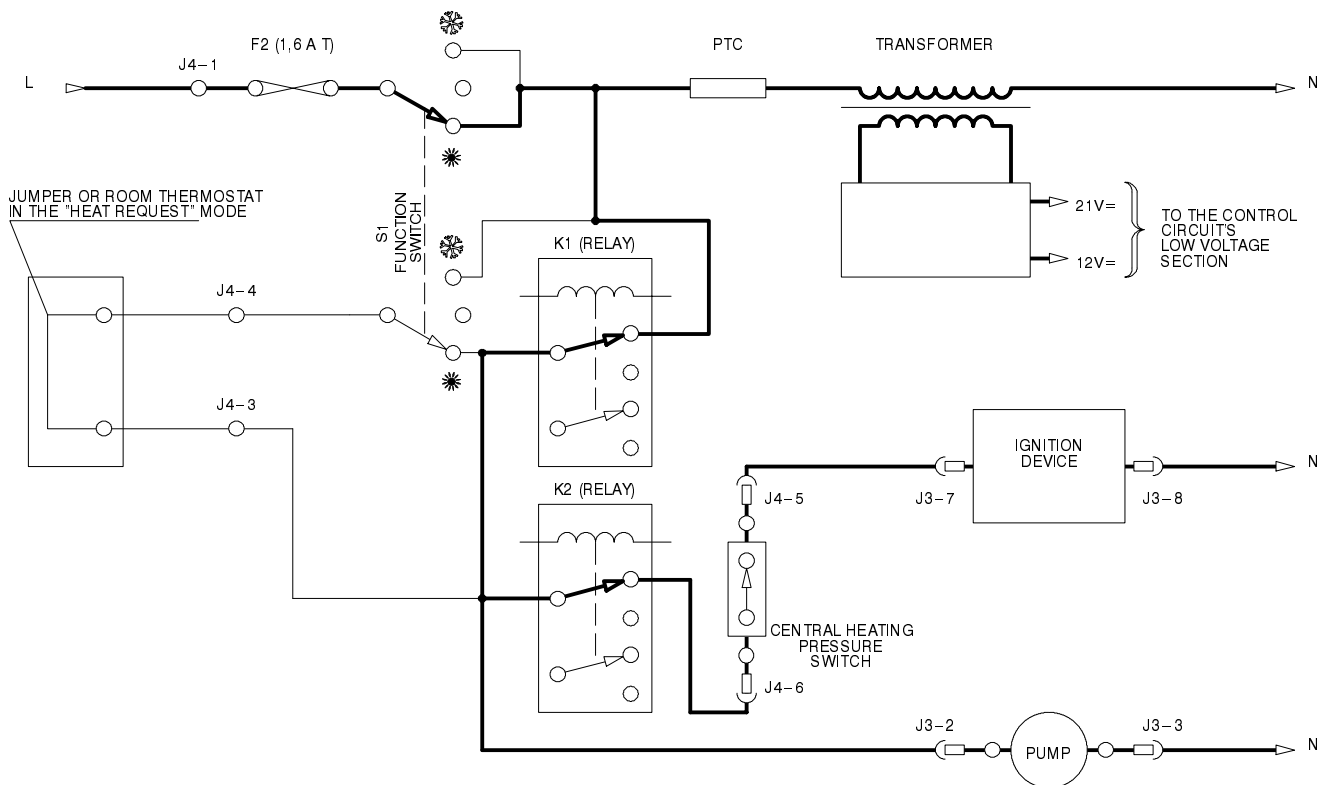

3.3 Control circuit voltages

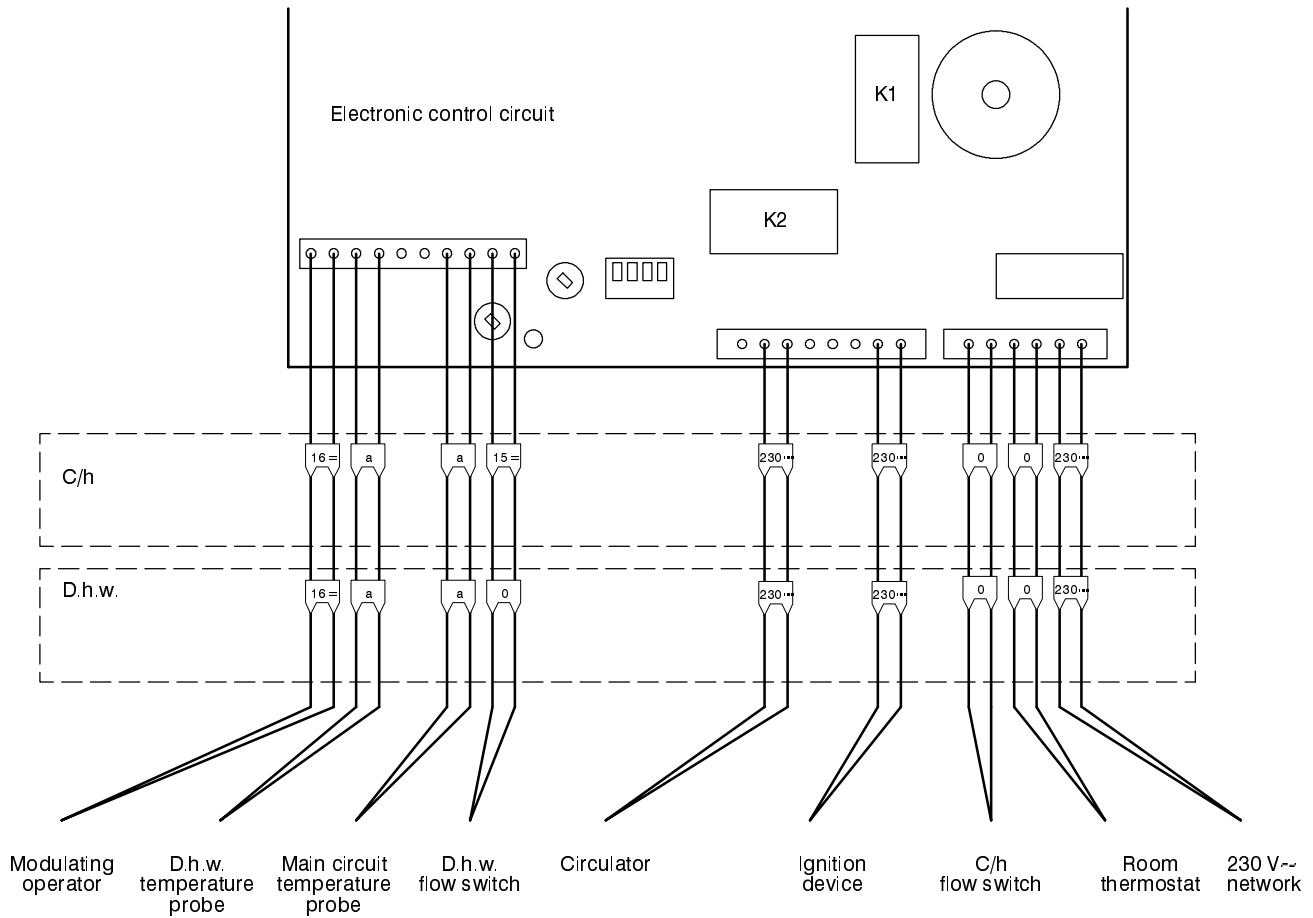

a: never zero (short circuit) never 12V= (open circuit)

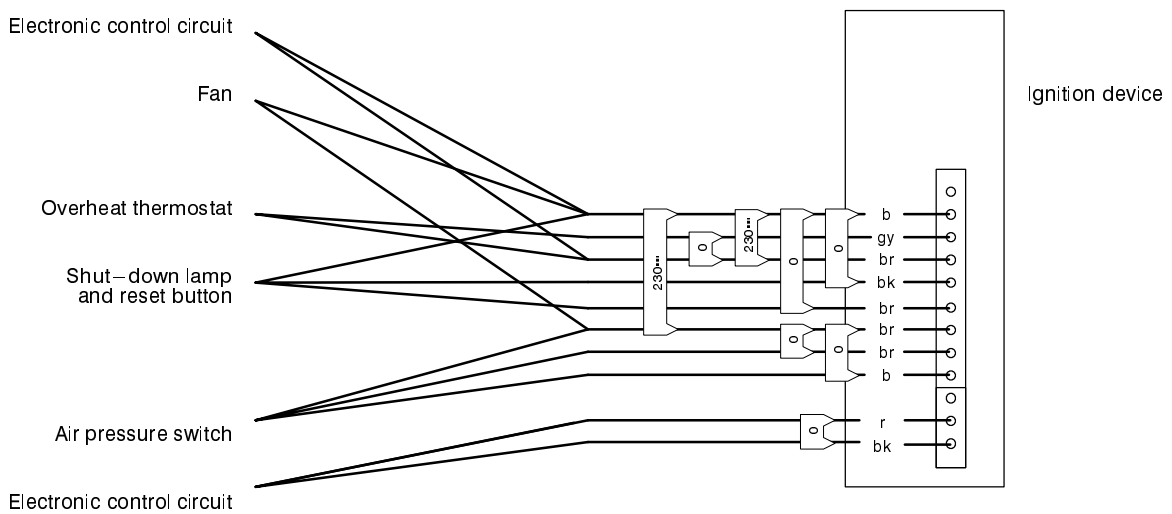

Electrical voltages in Volts during normal operation with burner on at maximum power

4 Fault finding

Section of the manual → (note ref. in brackets)	Components to check																						
	(1)	(2)	(3)	(4)	6	7.2	8.2	9.7	10.2	11.4	12.2	13.2	14.2	15	16.2	17.2	18.2	(7)	(8)	I	I		
Defect ↓																							
The boiler does not start either in c/h or d.h.w. mode. Fan still. Instrument panel light (green) off . Lockout lamp (red) off .	■							■															
The boiler does not start either in c/h or d.h.w.. mode. Fan still. Instrument panel light (green) on . Lockout lamp (red) off .				■																			
Lockout lamp (red) on . By pressing the reset push–button the boiler turns on and operates correctly.		■																					
Lockout lamp (red) on . By pressing the reset push–button the boiler starts the ignition cycle. The burner lights on , the ignition sparks continue and the boiler locks again.	■	■																					
Lockout lamp (red) on . By pressing the reset push–button the boiler starts the ignition cycle. The burner doesn't light on , the ignition sparks continue and the boiler locks again.		■																					
The boiler runs but the combustion is noisy and there is flame lift effect.			■																				
Incorrect modulation																							
The boiler switches on and off the burner to a fixed gas pressure																							

5 Main heat exchanger

5.1 Characteristics

The main heat exchanger (A in fig. 13) has the function of transferring heat of the gas produced by combustion to the water circulating in it.

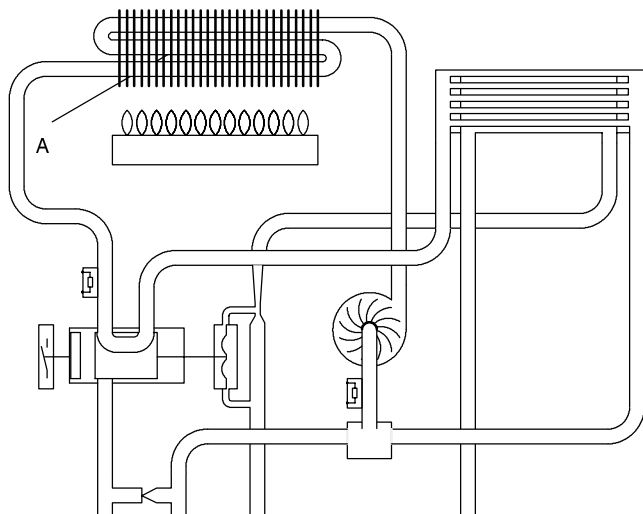

fig. 13

The hydraulic circuit consists of five elliptic pipes connected together in series (fig. 14).

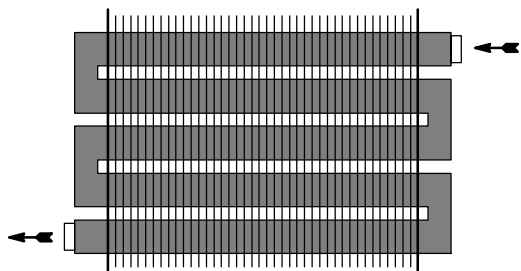

fig. 14

5.2 Removal

Warning: isolate the boiler from the mains electricity supply before removing any covering or component.

- 1 Empty the main circuit of the boiler
- 2 Remove the front panel of the body
- 3 Remove the sealed chamber cover.

For models 24S 24SR...

- 4a Remove the cover of the combustion chamber;
- 5a Remove the front part of the flue gas hood by unscrewing the screw B (fig. 15a)

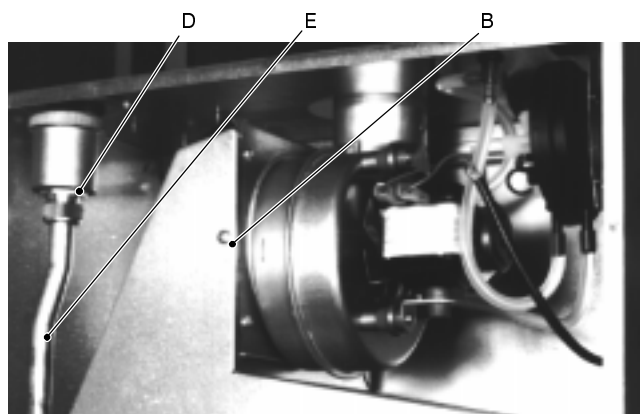

fig. 15a

For model 28S...

- 4b Remove the front part of the flue gas hood by unscrewing the four screws C (fig. 15b)
- 5b Remove the cover of the combustion chamber

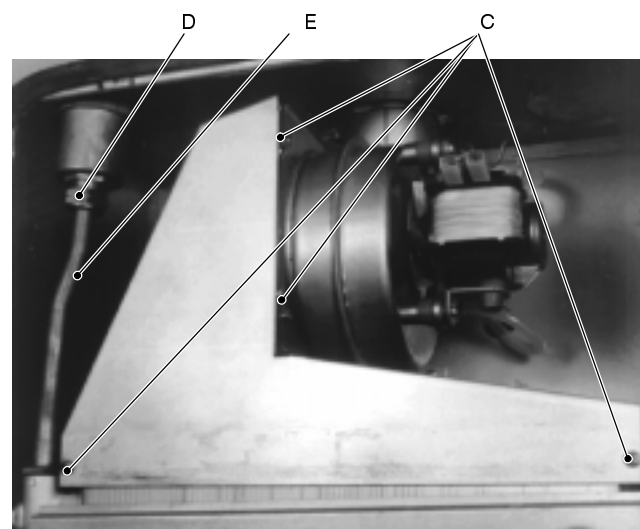

fig. 15b

- 6 Unscrew the automatic air valve connection nut D and remove the valve (fig. 15a);
- 7 Separate the heat exchanger from the hydraulic circuit, loosening the inlet and outlet pipe fittings);

For models 24S 24SR...

- 8a move the right pipe and free the right connection; lower the right side of the exchanger and extract it from the front;

For model 28S...

- 8b Extract the heat exchanger, from the front;
- 9 Unscrew the pipe E (fig. 15b) from the heat exchanger;
- 10 Assemble the heat exchanger carrying out the removal operations in reverse sequence.

5.3 Cleaning

If there are deposits of soot or dirt between the blades of the heat exchanger, clean with a brush or non-metallic bristle brush.

In any case, avoid any actions that can damage the protective varnish with which the exchanger has been covered.

6 D.h.w. heat exchanger

6.1 Function

The d.h.w. heat exchanger (A in fig. 16) allows the instantaneous transferral of heat from the primary hydraulic circuit to the water destined for d.h.w. use.

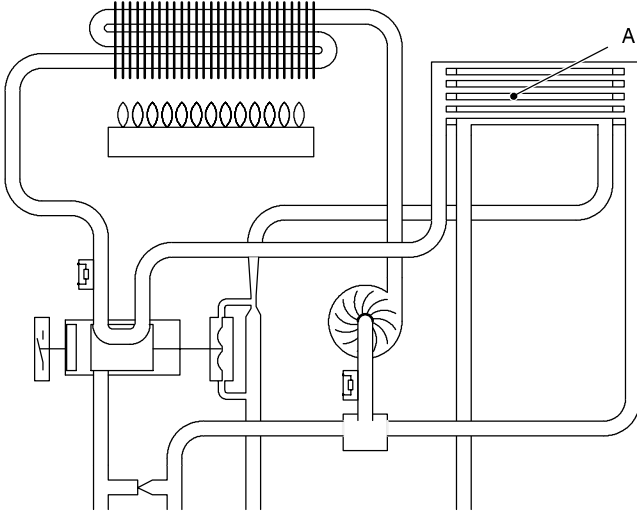
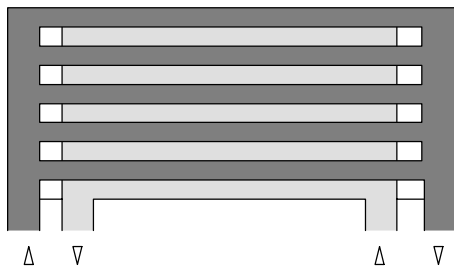

fig. 16

The schematic structure is shown in fig. 17.



- Primary hydraulic circuit
- Domestic hot water circuit

fig. 17

6.2 Removal

Warning: isolate the boiler from the mains electricity supply before removing any covering or component.

- 1 Empty the primary circuit and the d.h.w. circuit of the boiler
- 2 Remove the front panel of the body and lower the instrument panel

- 3 Completely unscrew the two screws B (in fig. 18 the right one is shown) which hold the exchanger to the brass deviator groups;

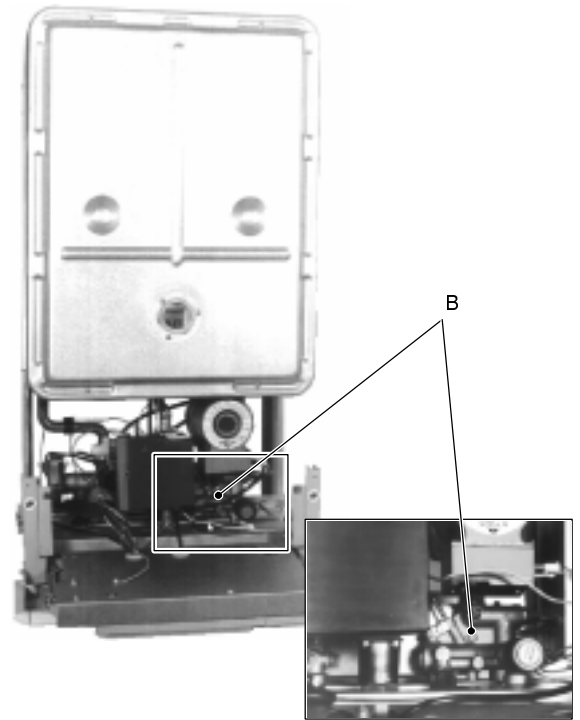

fig. 18

- 4 Move the exchanger towards the rear side of the boiler and extract it.

Reassemble the d.h.w. heat exchanger carrying out the removal operations in the reverse order.

Attention. Reassembling the exchanger be sure to put the off center location/securing pin indicated in fig. 19 towards the left side of the boiler.

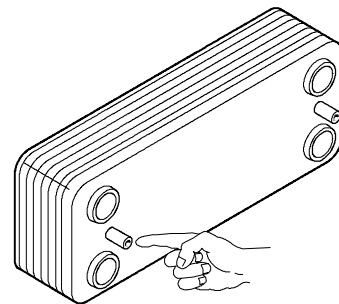

fig. 19

7 Pump

7.1 Function

The pump (A in fig. 20) has the function of making the water in the main circuit circulate through the main heat exchanger and therefore through the c/h system (during the c/h function) or through the secondary heat exchanger (during the d.h.w. function).

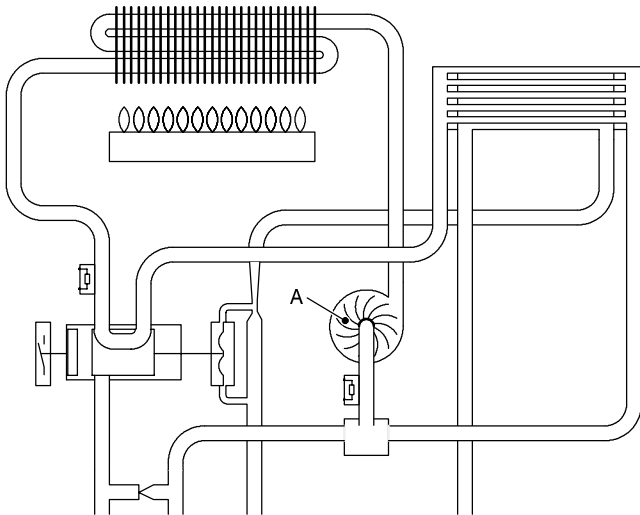

fig. 20

7.2 Checks

Warning: isolate the boiler from the mains electricity supply before removing any covering or component.

Check that the pump is not seized and that the movement of the rotor is not subject to mechanical impediments.

With the boiler off, remove the front panel and lower the instrument panel. Remove the air release plug of the pump and turn the rotor with a screwdriver.

Check the electrical completeness.

Remove the service panel, disconnect the connector to the electronic control circuit (see electrical diagram) and measure the electrical resistance between the pump supply conductors. (fig. 21).

Electrical resistance of the windings (at ambient temperature) on switch position 3 must be about:

- 210 Ω – Myson CP53
- 180 Ω – Myson CP63 (high head alternative)
- 220 Ω – Salmson MYE30
- 120 Ω – Salmson MYL50 (high head alternative)

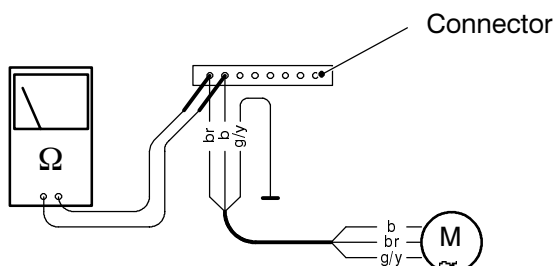

fig. 21

Check the absence of starting defects.

With the boiler off remove the front panel, lower the instrument panel

for Myson pump: unscrew the plug of the pump by hand (the plug cannot be removed). Pull it and turn the rotor. Start the boiler and verify if the motor runs.

for Salmson pump (high head alternative): remove the air release screw of the pump. Start the boiler and with a screwdriver, have the rotor turn in the direction of the arrow. If there is a defect in starting, the rotor will begin to turn normally only starting it manually.

Check that the impeller is integral with the rotor.

Remove the pump head losing the screws which hold it to the pump body and check that the impeller is firmly jointed with the rotor.

7.3 Removal

Warning: isolate the boiler from the mains electricity supply before removing any covering or component.

If the clearance to the right side of the boiler is restricted, the removal of the pump can be easily achieved by first removing the head by unscrewing the four Allen keys screws (B in fig. 22, the two on the upper side indicated).

- 1 Empty the main circuit of the boiler.
- 2 Remove the front panel of the body, the right side panel and overturn the instrument panel.
- 3 Disconnect the connector C (fig. 22).
- 4 Completely unscrew the connection nuts D and remove the pump.
- 5 Before the reassembling, carefully clean the support seat of the gasket.
- 6 Reassemble the pump carrying out the removal operations in the reverse order.

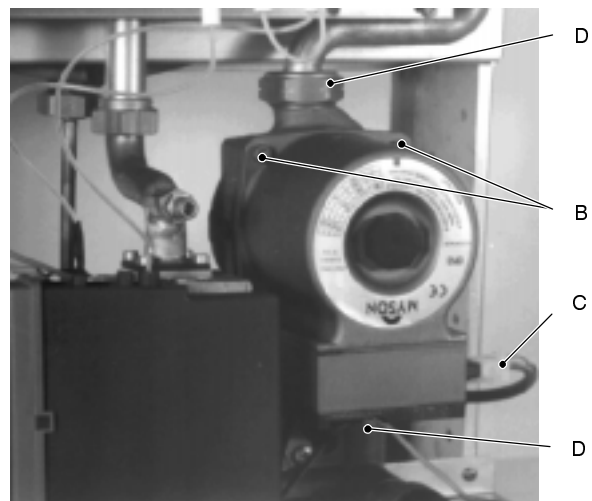

fig. 22

8 Diverter valve and d.h.w. pressure switch

8.1 Function

The diverter valve (A in fig. 23) has the function of modifying the hydraulic circuit of the boiler by means of an hydraulic command given by the opening of a d.h.w. tap in order to send the water that exits the main heat exchanger towards the c/h system or towards the d.h.w. heat exchanger.

Moreover it operates the d.h.w. pressure switch which acts on the electronic control circuit.

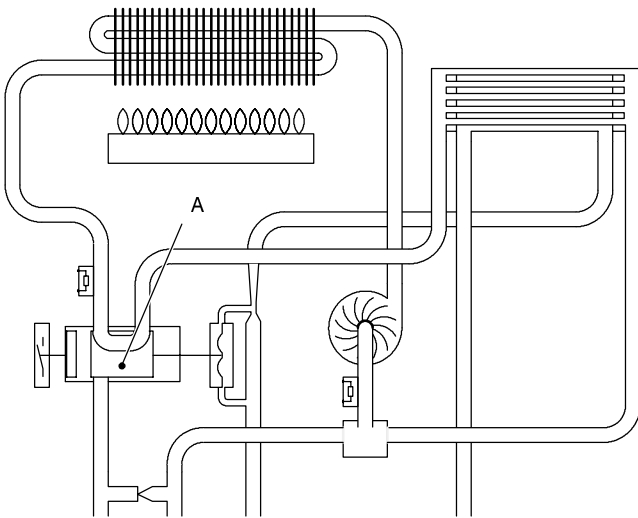



fig. 23

8.2 Checks

General check

It is possible to verify the general operation of the valve by measuring the voltage between the leads of the d.h.w. pressure switch during the operation on c/h and d.h.w.

Warning: isolate the boiler from the mains electricity supply before removing any covering or component.

- 1 Switch off the boiler and open the service panel.
- 2 Connect a meter, set for direct voltage measurement, to the points indicated in fig. 24.
- 3 Switch the boiler on  position and verify the voltages during c/h and d.h.w. by matching the readings with the values indicated in the section 3.3.

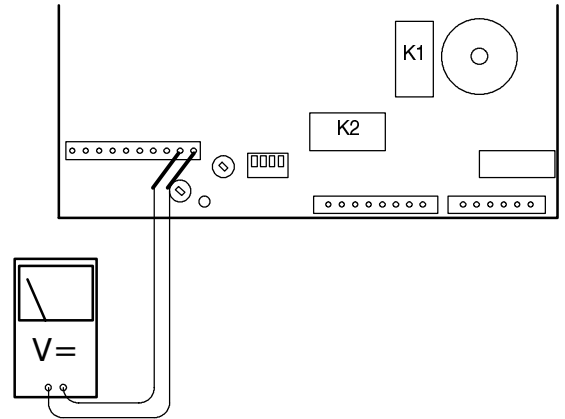

fig. 24

Check the mechanical function

- 1 Switch off the boiler; remove the front panel of the case, the lower protection plate and lower the control panel.
- 2 Remove the pressure switch as explained in the section 8.3 "Removal of the switch".
- 3 Open and close a d.h.w. tap and verify the position of the shaft B referring to fig. 25.

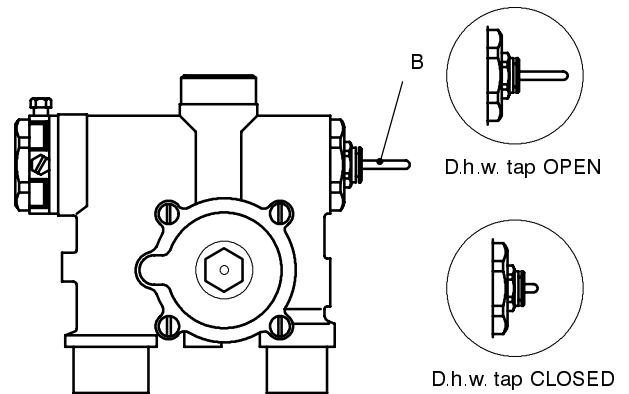

fig. 25

8.3 Removal

Warning: isolate the boiler from the mains electricity supply before removing any covering or component.

Removal of the membrane

- 1 Remove the front panel of the case, lower the control panel and empty the d.h.w. circuit.
- 2 Remove the forks C and move away the pipes D. (fig. 26 – rear view of the boiler).

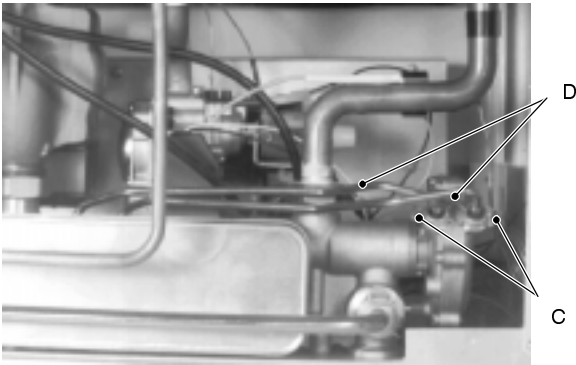

fig. 26

- 3 Loosen the screws *E* and remove the hydraulic actuator *F* (fig. 27).

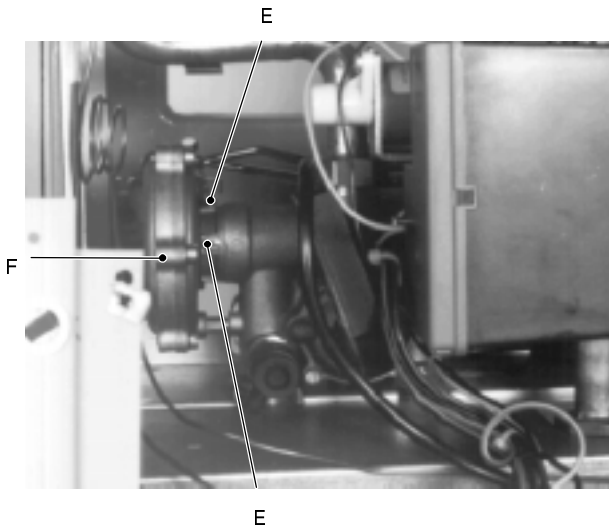

fig. 27

- 4 Unscrew the six screws *G*, open the hydraulic actuator and remove the membrane *H*. (fig. 28).

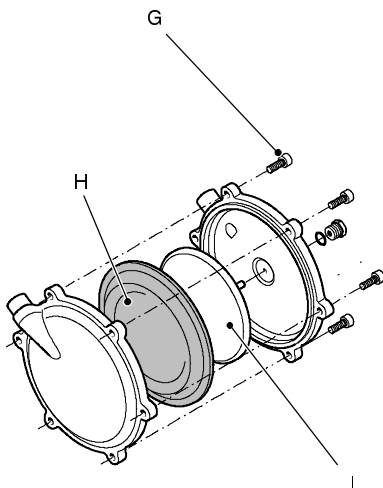

fig. 28

- 5 Assemble the part proceeding in reverse order.

Assembling the part, ensure to place the concave side of the membrane towards the actuator plate *I* (fig. 28).

When fixing the actuator to the valve, fit the reference shaft *J* in the seat of the valve (fig. 29).

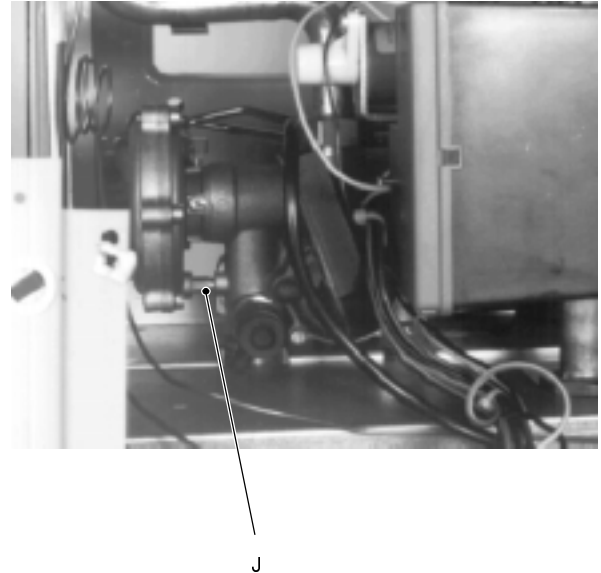

fig. 29

✓ Removal of the switch

- 1 Switch off the boiler; remove the front panel of the case, the lower protection plate and lower the control panel.
- 2 Remove the fork *K* that holds the d.h.w. pressure switch *L* placed on the right side of the valve and remove the switch (fig. 30).
- 3 Open the box and disconnect the switch.
- 4 Reassemble the switch proceeding in the reverse order.

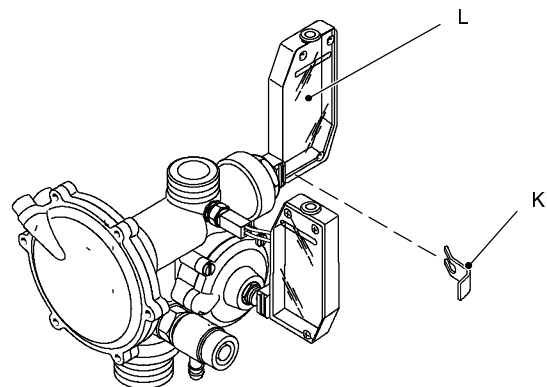

fig. 30

✓ Removal of the valve and the diverter mechanism

- 1 Switch off the boiler; remove the front panel of the case, the lower protection plate and lower the control panel.
- 2 Drain the d.h.w. and the c/h circuits.
- 3 Completely loosen the connections to the hydraulic circuits indicated in fig. 31.

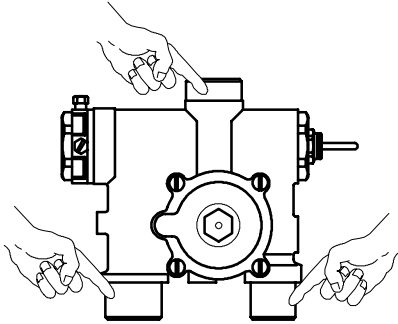

fig. 31

- 4 Remove the forks *M* and move away the pipes *N* (fig. 32).

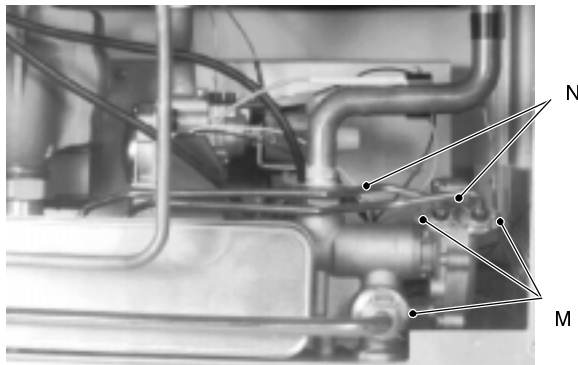

fig. 32

- 5 Remove the forks that hold the d.h.w. pressure switch *O* and the main circuit flow switch *P* and separate the switches from the valve (fig. 33).
- 6 Disconnect the temperature probe *Q*.

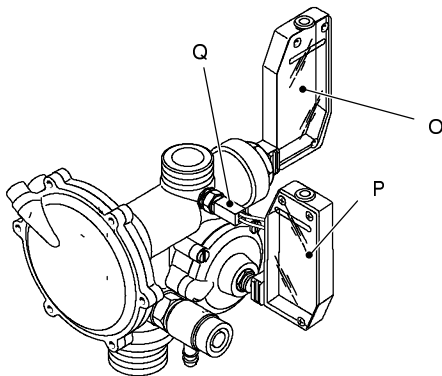

fig. 33

- 7 Unscrew the screw *R* that holds the d.h.w. heat exchanger, the bolt *S* that holds the valve to the frame (fig. 34) and remove the valve.

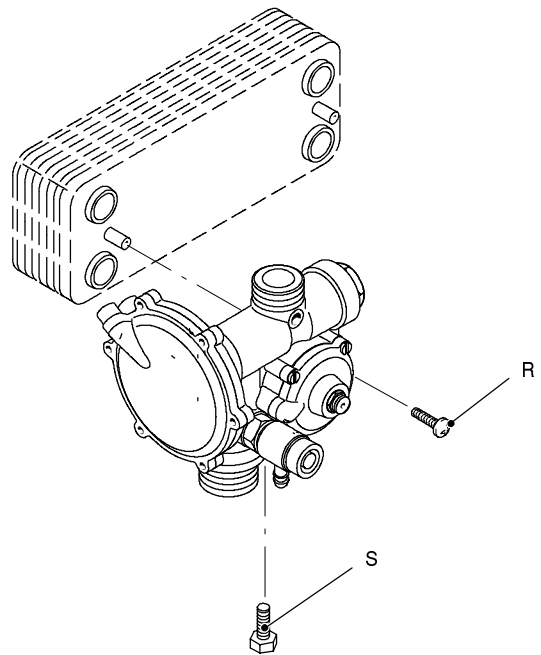

fig. 34

The diverter mechanism is composed by two parts. To reach them remove the hydraulic actuator as explained at the step 3 of the part *Removal of the membrane* of this chapter.

With a suitable spanner unscrew both plugs indicated in fig. 35 and remove the parts of the diverter mechanism.

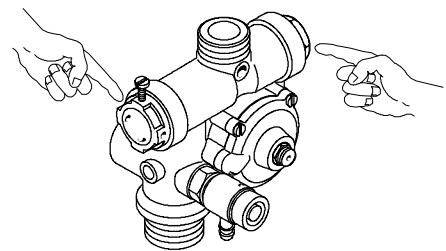

fig. 35

Reassemble the valve proceeding in the reverse order.

9 Electronic control circuit

9.1 Function

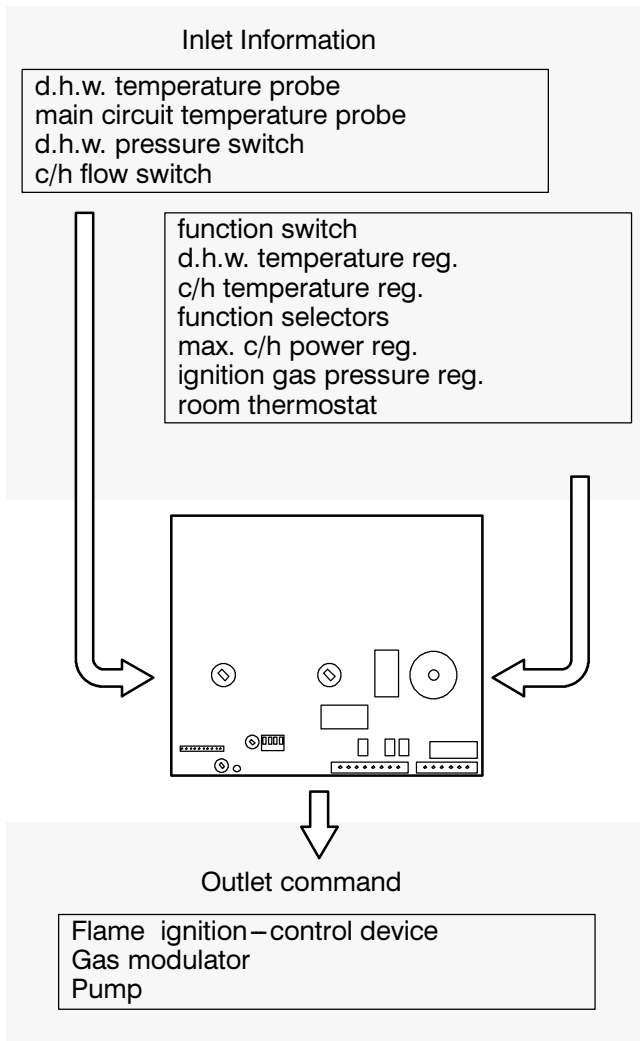

fig. 36

The fundamental function of the control circuit is that of controlling the boiler in relation to the external needs (heating the room, heating the water for d.h.w. use) operating in order to keep the temperature of the hydraulic circuits constant.

This is obviously possible within the useful power and maximum working temperature limits foreseen.

Generally, the control circuit receives inlet information coming from the boiler (the sensors) or from the outside (knobs, room thermostat, etc.), processes them and consequently acts with outlet commands on other components of the boiler (fig. 36).

9.2 Selection and adjustment devices

On the control circuit several selection, adjustment and protection devices are located. (fig. 37).

Several of these devices are directly accessible by the user (function switch, temperature adjustment potentiometers etc.) others are accessible by removing the service panel.

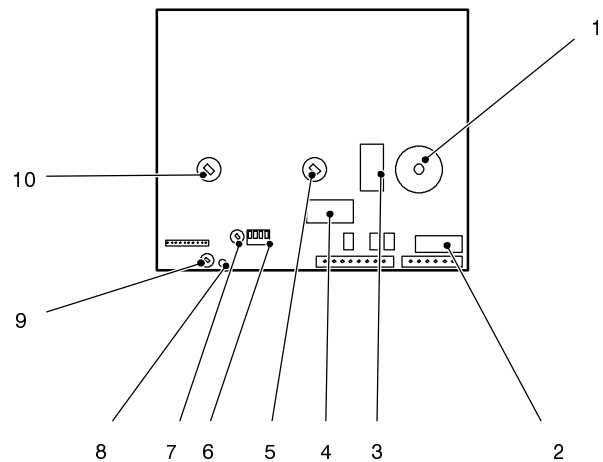

fig. 37

- 1 function switch
- 2 fuse F2 (1,6 A)
- 3 K1 relay
- 4 K2 relay (ignition device control)
- 5 d.h.w. temperature reg. potentiometer
- 6 function selectors
- 7 ignition gas pressure adjustment (ACC.)
- 8 green LED (boiler on)
- 9 c/h maximum power adjustment (RISC.)
- 10 c/h temperature reg. potentiometer

9.3 Checking the temperature

The control circuit makes it possible to separately adjust the c/h water flow and d.h.w. outlet temperature.

The temperature of the water is converted into an electric signal by means of temperature probes.

The user, setting the desired temperature with the knobs of the instrument panel operates the variable elements (5 and 10 in fig. 37) of the control circuit.

If the power requested is lower by about 40% of the maximum useful output, the control is done by igniting at the minimum power and turning off the burner (on-off function). If the power is higher the boiler will modulate down to 40% of its maximum power output.

When the boiler functions in c/h (fig. 38), the signal coming from the primary temperature probe is compared to the signal given by the instrument panel through the adjustment made by the user (knob 10). The result of such a comparison operates the modulation of the gas valve, consequently changing the instantaneous useful output of the boiler.

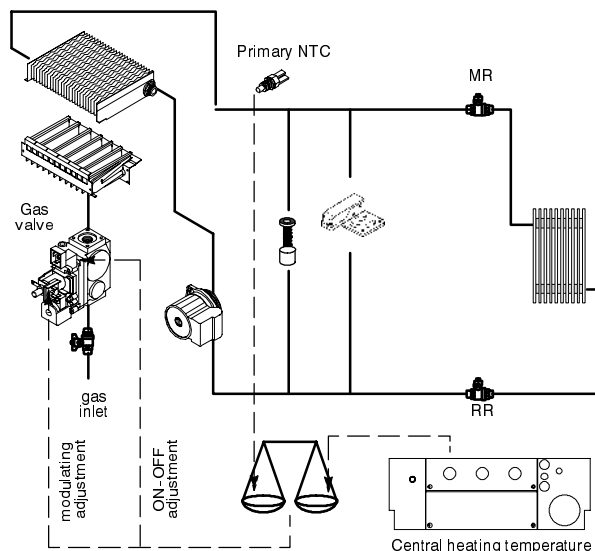

fig. 38

When the boiler functions in d.h.w. (fig. 39), the signal coming from the d.h.w. temperature probe is compared with the signal given by the instrument panel through the adjustment made by the user (knob).

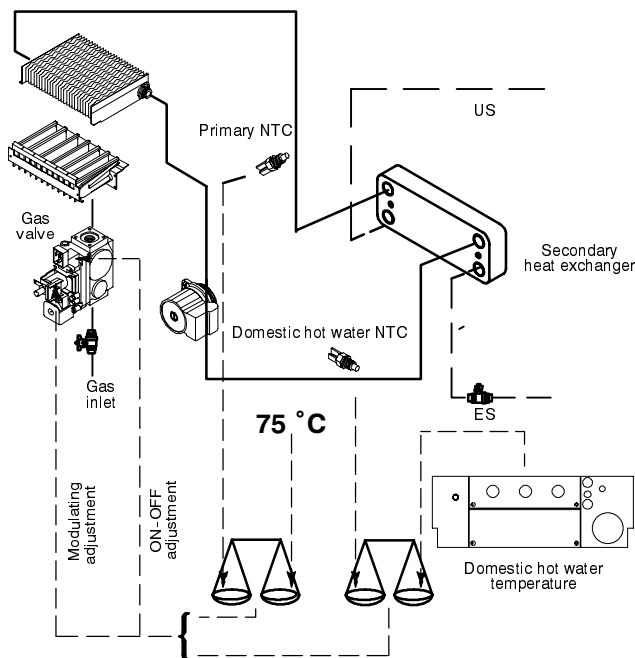

fig. 39

Normally, the result of the comparison between these two signals directly operates the adjustment elements of the gas valve, adjusting the useful output generated in order to stabilize the temperature of the exiting water.

If during the functioning in d.h.w. mode, the temperature of the primary circuit goes over 75°C, the useful output is automatically reduced so that the primary circuit cannot reach excessive temperatures.

The control sequences in function and in function are illustrated in detail in sections 9.9 and 9.10.

9.4 Function selectors

The function selectors "6" (fig. 37 and fig. 40) are microswitches with which it is possible to select the various modes of functioning of the boiler.

In fig. 40 the selectors are illustrated in the configuration in which the p.c.b. is set in the factory (natural gas boiler).

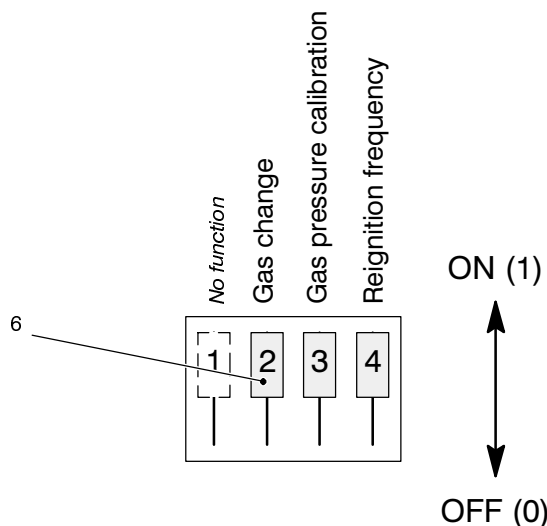

fig. 40

○ Selector 2

It selects the functioning of the boiler on the basis of the type of gas used.

It allows the selection of the maximum supply current given to the modulator device.

To set correctly the selector follow the table of fig. 41.

Gas supply	Position of selector	Approx. Max current trough the modulator device
Natural gas	On	120 mA
L.P.G.	Off	165 mA

fig. 41

○ Selector 3

It forces the functioning of the boiler in order to permit the optimal gas pressure at the burner to be adjusted during the ignition phase.

The adjustment (see section 9.5) is done by means of the potentiometer "7" marked "ACC" (fig. 37).

After the adjustment operations bring the selector back to the normal position (ON).

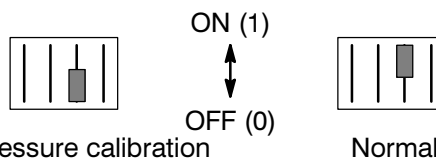

fig. 42

○ Selector 4

It makes it possible to select the minimum time that must pass between two ignitions of the burner in c/h function.

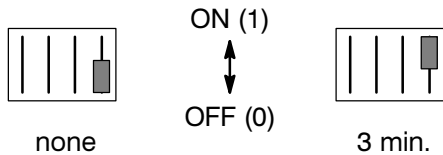

fig. 43

9.5 Ignition gas pressure regulator

By using the device "7" (fig. 37) marked "ACC." on the circuit board, it is possible to adjust the gas pressure at the injectors in the ignition phase.

This pressure is maintained at the injectors until ignition occurs (ionization signal).

To carry out the adjustment move the function selector n° 3 downwards (adjustment) and use the adjustment device "7" (ACC).

Bring the gas pressure at the injectors to the value indicated in the tables "data for gas adjustment" stated for each model in the second part of the manual (ignition pressure).

By rotating the device clockwise the pressure increases.

Check the regular ignition of the burner by turning the boiler on and off repeatedly.

After the adjustment operation move the selector upwards (normal).

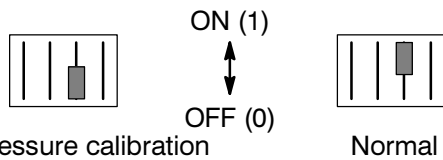

fig. 44

9.6 Max. c/h power regulator

By using device 9 (fig. 37) marked "RISC." on the circuit board, you can limit the maximum useful output delivered in the c/h function. This adjustment does not influence the maximum useful output delivered in d.h.w. function.

By rotating the device clockwise the pressure increases.

9.7 Checks

✓ Check that the fuse is complete

If the control circuit does not supply any device (pump, gas valve, etc.) check that the fuse F2 is complete (fig. 45).

The F2 fuse can be reached by removing the service panel.

If the fuse is blown replace it with one that has the same characteristics after having identified the cause of the interruption.

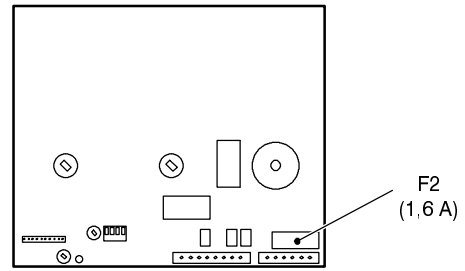

fig. 45

9.8 Removal of the control circuit

Warning: isolate the boiler from the mains electricity supply before removing any covering or component.

- 1 Remove the boiler's front panel;
- 2 unscrew the six screws A (fig. 46) and remove both panels;

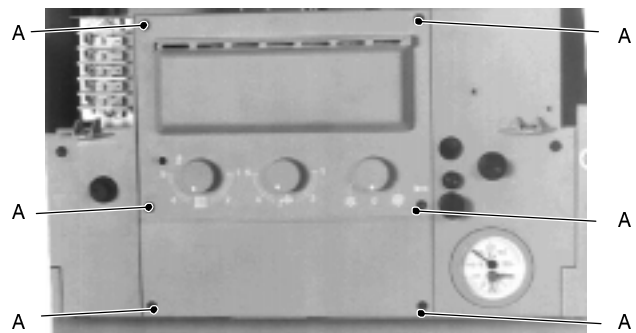

fig. 46

- 3 Delicately flex the hooks indicated in fig. 47 and disconnect the connectors B
- 4 Unscrew the four screws C and remove the circuit (fig. 47);

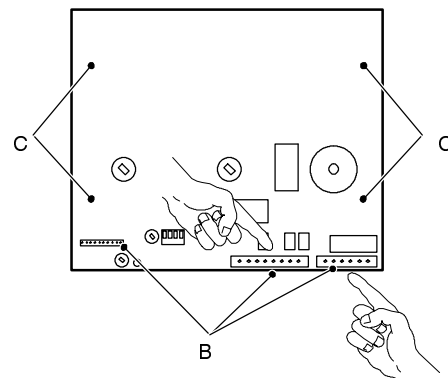

fig. 47

- 5 assemble the control circuit following the disassembly procedures in the reverse order.

Attention: after having installed the control panel make sure the central heating () and domestic hot water temperature () adjustment knobs can move freely (half a turn).

9.9 Thermal control in the "❄" mode

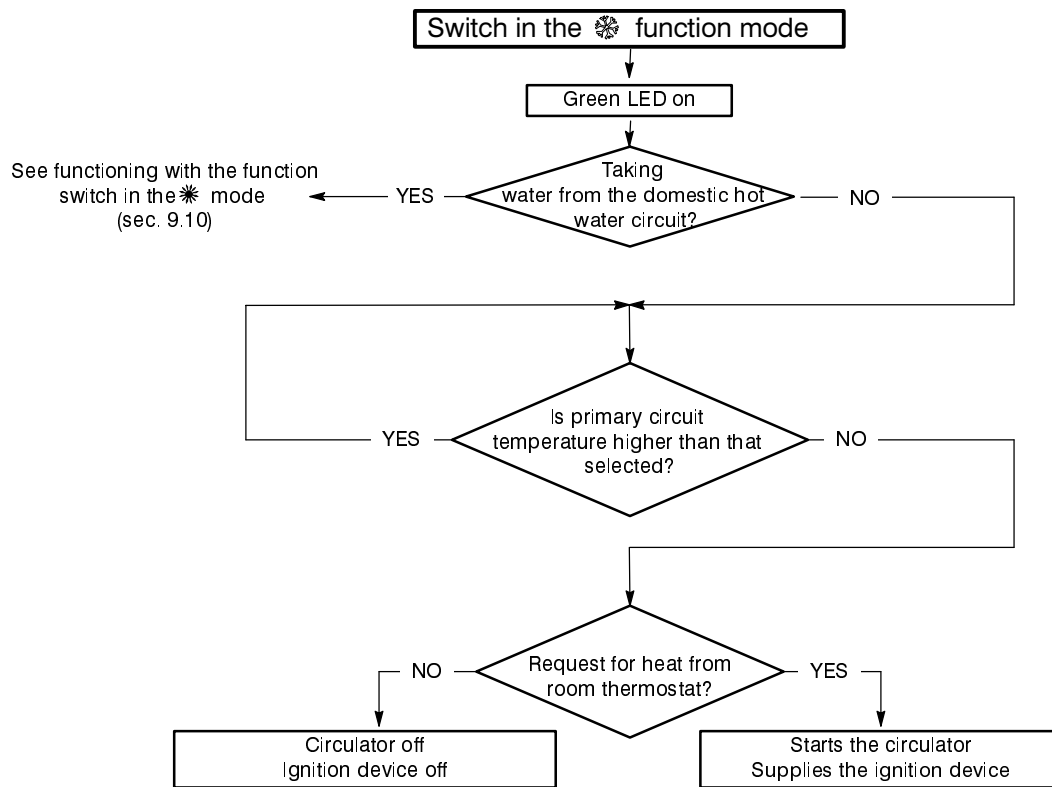

fig. 48

9.10 Thermal control in the "❄" mode

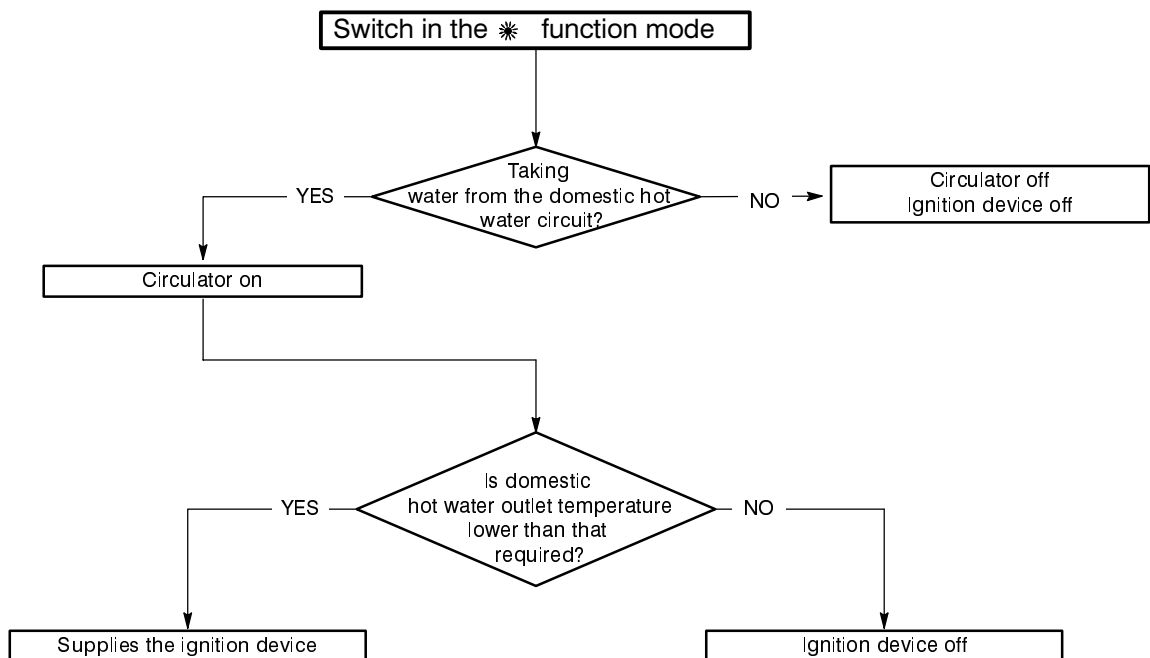

fig. 49

10 Full sequence ignition device

10.1 Function

The ignition and flame control device, type S4565DD, used on electronic ignition boilers with forced flue gas expulsion carries out the following fundamental functions:

- does a sequence of operations (ignition cycle) which lead to the ignition of the gas at the burner
- checks the presence of the flame during the entire period in which it is activated
- supplies the fan and checks its functioning by means of the signal coming from the flue gas pressure switch.

The ignition device is supplied by the electronic control circuit when the ignition of the burner is requested.

The ignition device has a **safety function** and any incorrect interventions or tampering can result in conditions of dangerous functioning of the boiler.

The ignition device can lock the functioning of the boiler (lock state) and stop its functioning up to the resetting intervention. The lock is signalled by the ignition of the lock lamp and the device can be reset only by using the reset push-button placed on the instrument panel.

Some components which are connected to the device that, can activate the lock state. The causes of a lock state could be:

- the intervention of the safety thermostat (primary hydraulic circuit)
- a fault on gas feeding
- faulty ignition (ignition electrode, its wiring and connection)
- faulty flame detection (detection electrode, its wiring and connection)
- gas injectors plugged
- faulty gas valve (on-off operators) or not electrically supplied
- faulty ignition device

other components like the flue gas pressure switch can temporarily stop the ignition of the burner but allow its ignition when the cause of the intervention has stopped.

fig. 52 shows the sequence of the operations that are carried out at the starting of every ignition cycle and during normal functioning.

10.2 Checks

➤ Shutdown sequence

Start the boiler until the burner is ignited.

While the burner is on, turn the gas supply off. The device should carry out a complete ignition cycle and then shutdown.

When turning the boiler on and off with the function switch, the device should not reset itself and the burner should not turn on.

10.3 Removal

⚡ **Warning: isolate the boiler from the mains electricity supply before removing any covering or component.**

- 1 Remove the front panel of the case and lower the control panel;
- 2 Unscrew screw *A* and remove the protection cover *B*; disconnect the flame detection cable *C* and the ignition cable *D* (fig. 50);

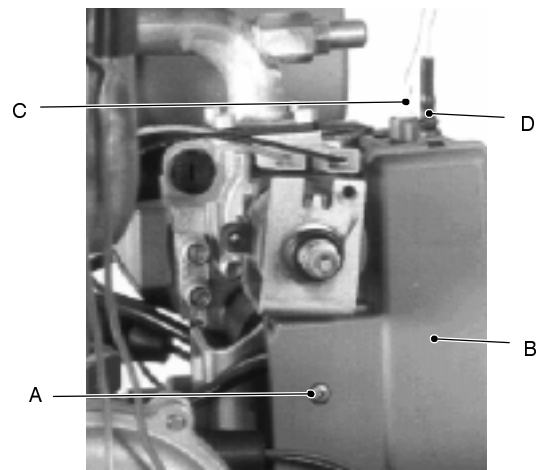

fig. 50

- 3 remove the cable clamp and disconnect the two wires;
- 4 remove the ignition device by moving it from towards left (fig. 51);

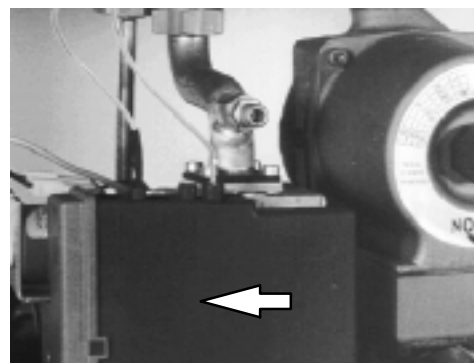

fig. 51

10.4 Ignition sequence

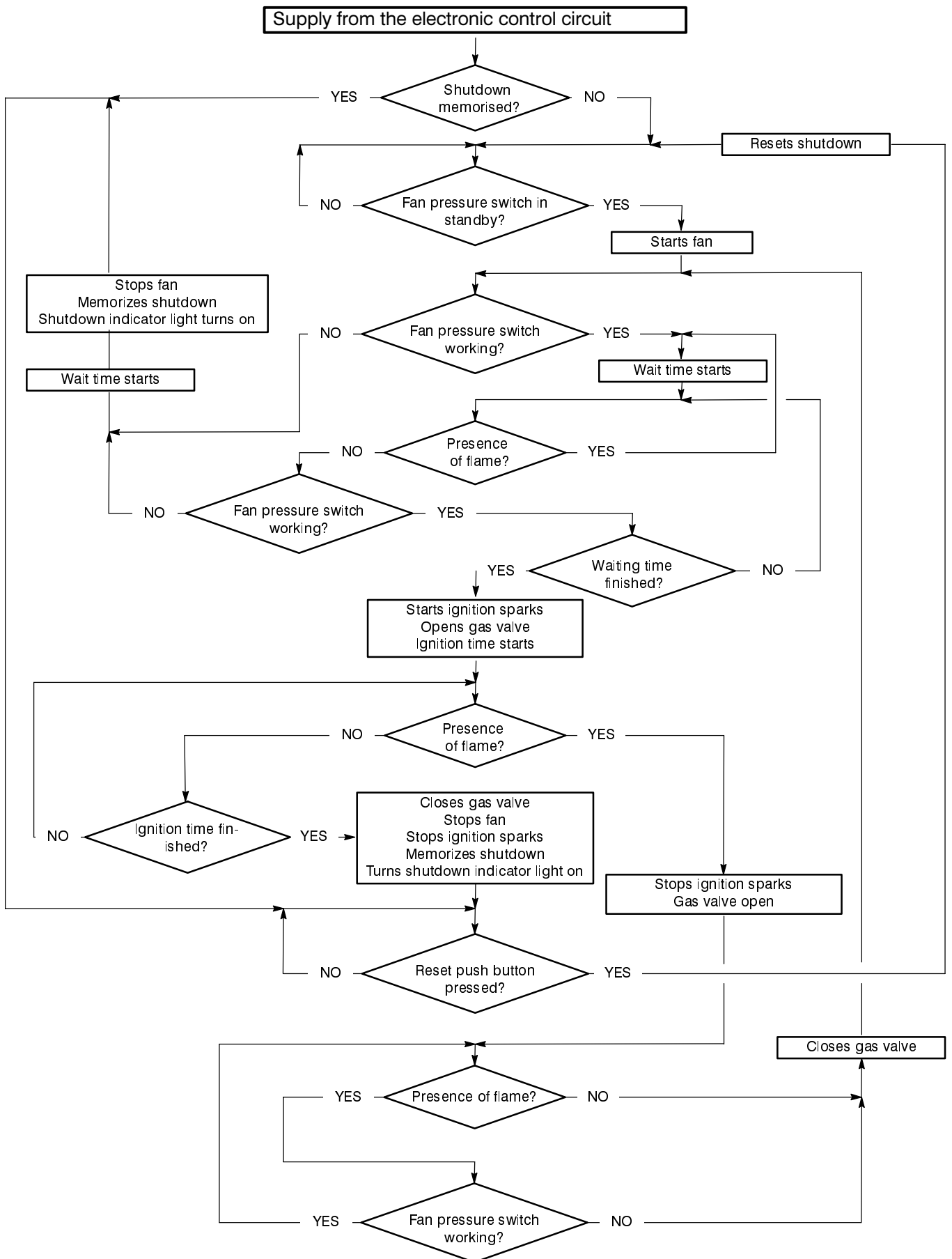

fig. 52

11 Gas valve

11.1 Function

The gas valve controls the gas inflow to the boiler burner.

By means of an electric command given to the on-off operators the passage of the gas through the valve can be opened or closed.

By means of an electric command given to the modulating operator the pressure can be varied and therefore the gas flow rate to the burner (modulation). The modulator device has mechanical organs which permit the adjustment of the minimum and maximum pressure exiting the valve.

11.2 Nomenclature of the parts

- 1 On-off operators
- 2 Modulating operator
- 3 Modulating operator's electric connectors
- 4 Valve inlet gas pressure test point
- 5 Valve outlet gas pressure test point
- 6 Gas pressure maximum adjuster
- 7 Gas pressure minimum adjuster

11.3 Adjustment

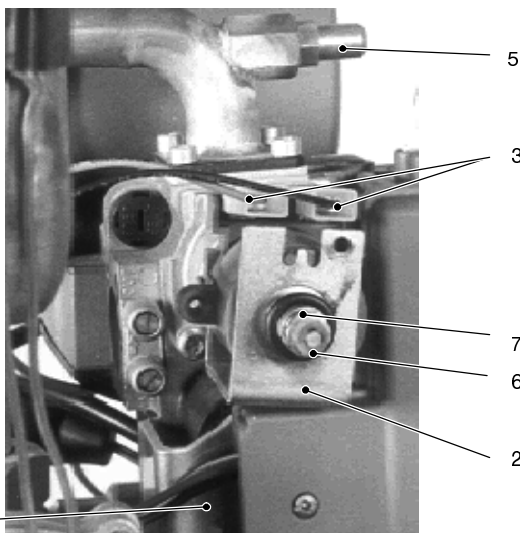

fig. 53

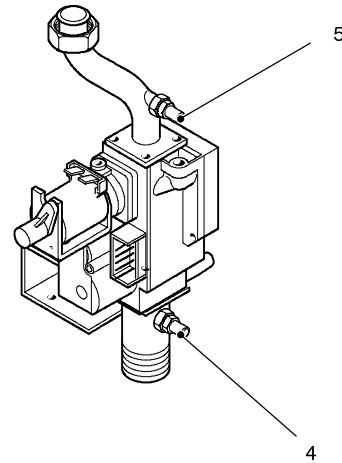

fig. 54

Warning: isolate the boiler from the mains electricity supply before removing any covering or component.

- 1 Open the gas pressure tap "4" at the valve input, connect a gauge and check the gas pressure of the supply network;
- 2 close the gas pressure tap "4";
- 3 open the gas pressure tap "5" at the valve output and connect a pressure gauge;
- 4 remove the protection cap from the mechanical pressure adjustment elements;
- 5 disconnect one of the two connectors "3" of the modulating operator;
- 6 start the boiler;
- 7 rotate the minimum pressure adjuster "7" until you obtain the expected pressure (by rotating clockwise the pressure increases);
- 8 turn the boiler off and connect the wire to the modulating operator;
- 9 start the boiler;
- 10 rotate the maximum pressure adjuster "6" until you obtain the expected pressure (by rotating clockwise the pressure increases);
- 11 turn the boiler off and disconnect the gauge;

At the end of the adjustment ensure to seal the gas test point.

11.4 Checks

Warning: isolate the boiler from the mains electricity supply before removing any covering or component.

- ✓ Check the modulating operator coil
- 1 Remove the front panel of the case and lower the control panel.
 - 2 Disconnect one of the two connectors "3" of the modulating operator and measure the electrical resistance of the coil.
Its electrical resistance value must be approx. 125 Ω.

- ✓ Check the modulating operator coil
- 1 Remove the front panel of the case and lower the control panel.
- 2 Remove the full sequence ignition device (see the related chapter of this manual).
- 3 Measure the electrical resistance between the leads of the on–off operators as illustrated in fig. 55.

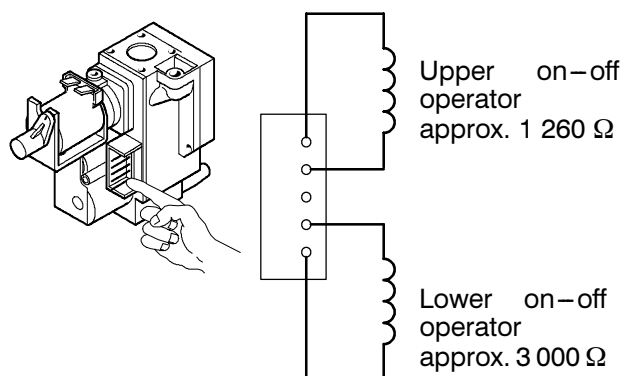

fig. 55

11.5 Removal

- ⚡ **Warning:** isolate the boiler from the mains electricity supply before removing any covering or component.

- 1 Remove the front panel of the case and lower the control panel.
- 2 Remove the full sequence ignition device (see the related chapter of this manual).
- 3 Disconnect the modulating operator.
- 4 Unscrew the eight screws indicated in fig. 56 and remove the valve.
- 5 Reassemble the valve carrying out the removal operations in reverse order.

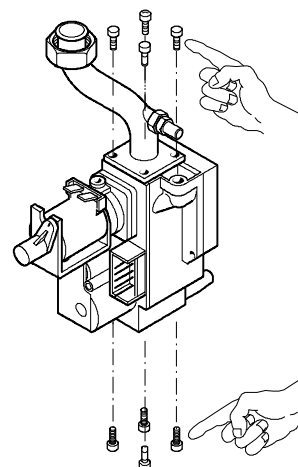

fig. 56

12 Main circuit flow switch

12.1 Function

The main circuit flow switch (A in fig. 57) is a device that controls the speed of water that crosses the main heat exchanger.

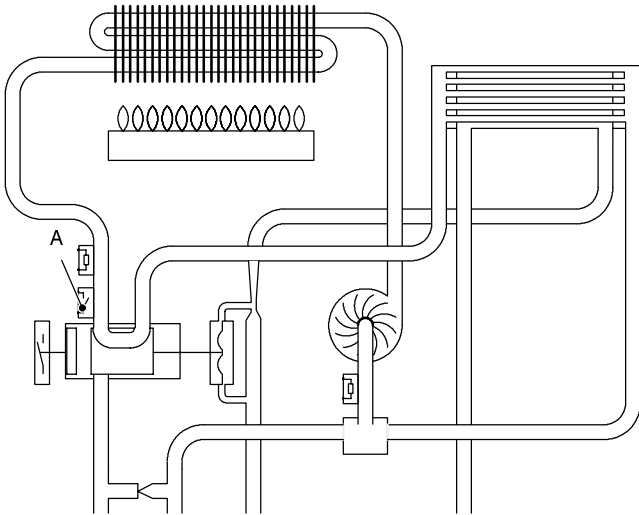

fig. 57

This device controls the regular functioning of the pump, the presence of water in the primary circuit of the boiler and the absence of obstructions of the main heat exchanger during the c/h function as well as during the d.h.w. function.

As a consequence of any one of these causes the main circuit flow switch cuts – off an electric circuit by means of a microswitch (B in fig. 59) installed on it.

The main circuit flow switch is connected to the electronic control circuit and its intervention prevents or stops the burner ignition cycle but does not send the boiler in the lock state.

12.2 Checks

Warning: isolate the boiler from the mains electricity supply before removing any covering or component.

General check

It is possible to verify the general operation of the switch by measuring the voltage between its leads during the operation on c/h or d.h.w.

Warning: isolate the boiler from the mains electricity supply before removing any covering or component.

- 1 Switch off the boiler and open the service panel.
- 2 Connect a meter, set for alternating voltage (230V) measurement, to the points indicated in fig. 58.
- 3 Switch the boiler on  position and verify the voltage by matching the readings with the values indicated in the section 3.3.

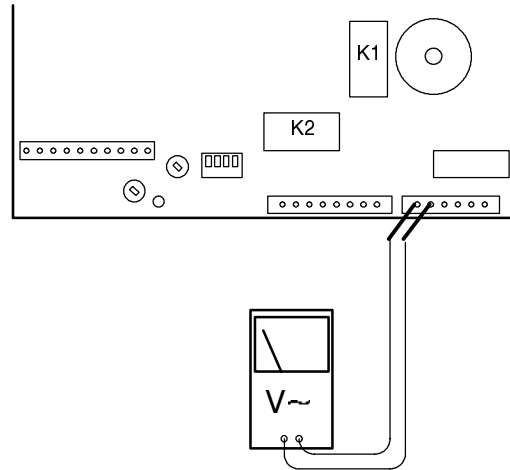

fig. 58

Mechanical function

- 1 Remove the front panel of the case and lower the control panel.
- 2 Remove the fork C that holds the main circuit flow switch B (fig. 59).

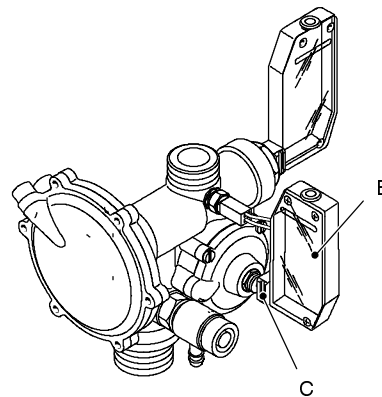

fig. 59

- 3 Start and stop the boiler in c/h operation (time switch and external controls must call for heat) and verify the position of the shaft D referring to fig. 60

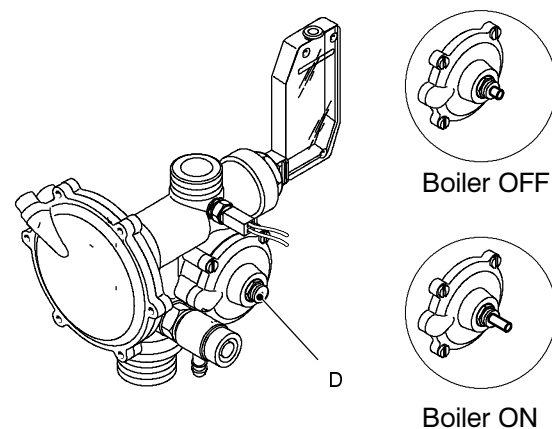

fig. 60

12.3 Removal

Warning: isolate the boiler from the mains electricity supply before removing any covering or component.

- ✓ Removal of the membrane
- 1 Remove the front panel of the case, lower the control panel and empty the main circuit.
- 2 Remove the fork *E* that holds the main circuit flow switch *B* (fig. 59).
- 3 Unscrew the four screws *F*, open the hydraulic operator and remove the membrane *G* (fig. 61).

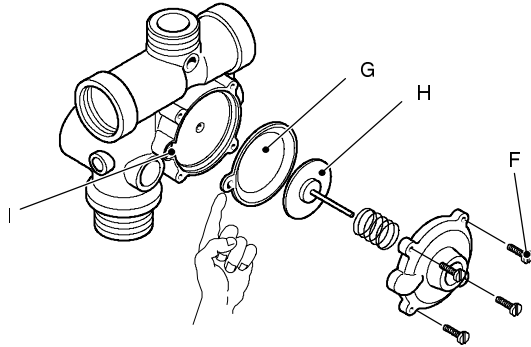

fig. 61

- 4 Assemble the part proceeding in reverse order.

Assembling the part, ensure to place the concave side of the membrane towards the actuator plate *H* and the reference hole indicated in the seat *I* (fig. 61).

- ✓ Removal of the switch
- 1 Switch off the boiler; remove the front panel of the case, the lower protection plate and lower the control panel.
- 2 Remove the fork *C* that holds the switch placed on the valve and remove the switch (fig. 59).
- 3 Open the box and disconnect the switch.
- 4 Reassemble the switch proceeding in the reverse order.

13 D.h.w. filter and flow limiter

13.1 General notes

The input port of the d.h.w. circuit is provided with a net filter and its function is to stop the passage of any impurities through the circuit.

The d.h.w. filter is located in the c.h. return group (indicated in fig. 62).

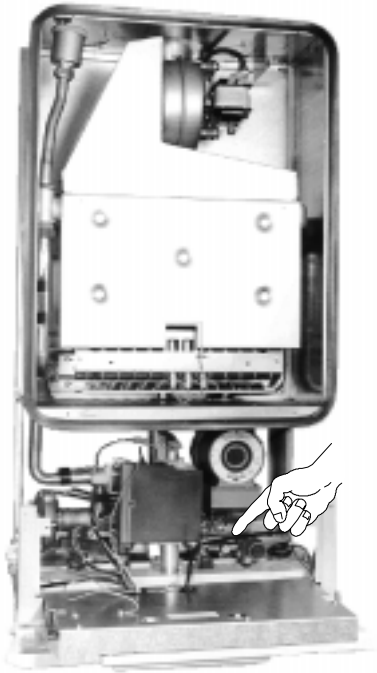

fig. 62

13.2 Removal of the filter

Warning: isolate the boiler from the mains electricity supply before removing any covering or component.

- 1 Remove the front panel of the case, the lower protection plate, lower the control panel and empty the d.h.w. circuit.
- 2 Unscrew the plug A (fig. 63) and extract the filter.

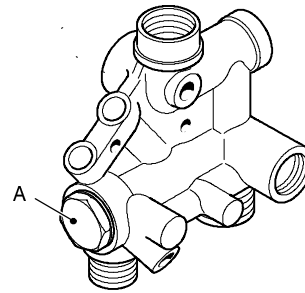

fig. 63

13.3 Flow limiter

If the flow rate of the d.h.w. circuit is too high, it is possible to limit it installing a flow limiter. The following sizes are available:

Nominal flow rate (litres/min)	Colour
10	Blue
12	Red

To install the flow limiter operate as in the following sequence:

- 1 Remove the d.h.w. filter as explained in the section 13.2.
- 2 Unscrew the part B (fig. 64) and remove it from the body of the filter.
- 3 Install the flow limiter C putting its smaller diameter side towards the part B.
- 4 Install the filter following the removing sequence in reverse order.

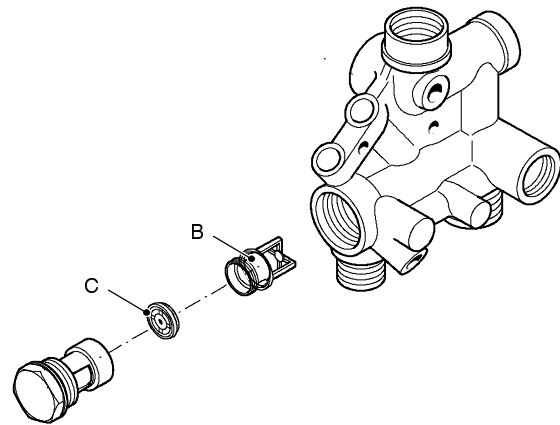

fig. 64

14 Temperature probes

14.1 Function

The temperature probe has the function of converting the temperature of the water of the hydraulic circuit where it is installed into an electric signal (resistance).

The relation between temperature and electrical resistance is stated in fig. 65.

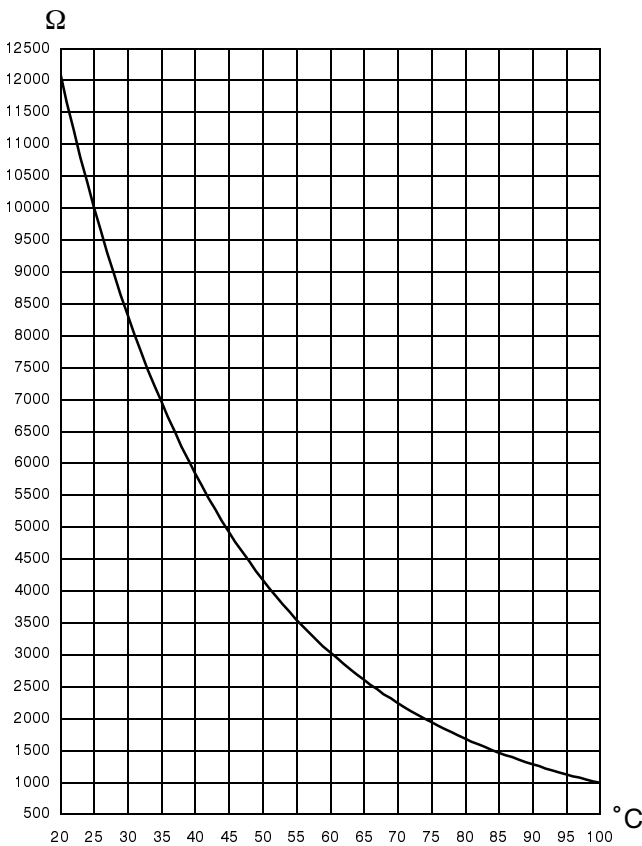

fig. 65

In the boilers with mixed function (c/h + d.h.w.) two temperature probes are assembled, one on the output of the main heat exchanger (main circuit temperature probe) A, (fig. 66 and fig. 67) one on its input, before the pump (d.h.w. temperature probe) B (fig. 66 and fig. 68).

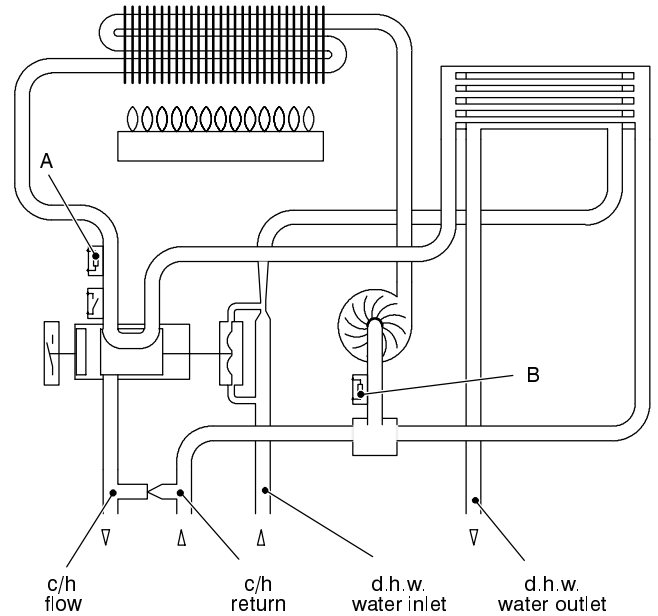

fig. 66

14.2 Checks

✓ Temperature-resistance relationship

⚡ **Warning: isolate the boiler from the mains electricity supply before removing any covering or component.**

Disconnect the cable from the temperature probe. Measure the temperature of the pipe near the temperature probe and check the electrical resistance according to the graph in fig. 65.

Remember that a temperature probe failed in short circuit sends a signal to the control circuit at a temperature equivalent to 100°C. A disconnected or interrupted temperature probe sends a signal at a temperature equivalent 0°C thus the burner will always be on maximum power.

14.3 Removal

⚡ **Warning: isolate the boiler from the mains electricity supply before removing any covering or component.**

To remove the main circuit or the d.h.w. temperature probes follow the same sequence.

Refer to fig. 67 for the main circuit temperature probe, to fig. 68 for the d.h.w. temperature probe.

- 1 remove the front panel of the case and lower the instrument panel
- 2 empty the main circuit of the boiler.
- 3 remove the electric connector of the temperature probe and unscrew it.
- 4 assemble the temperature probe carrying out the removal operations in reverse order.

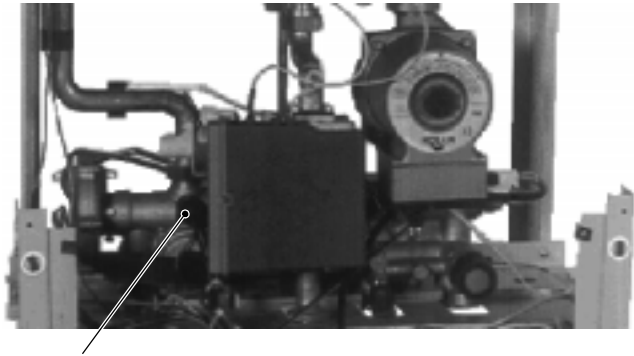

A

fig. 67

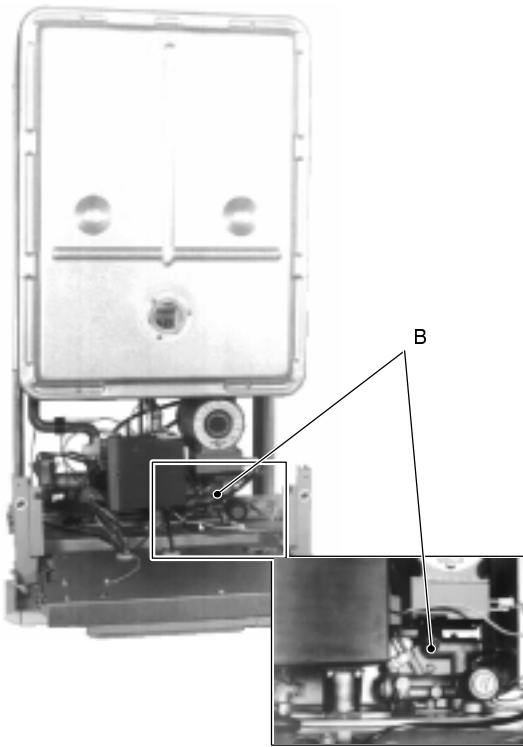

B

fig. 68

15 By-pass valve

15.1 Function

The by-pass valve is located between the c/h water flow and return (A in fig. 69) and its function is that of guaranteeing a minimum flow across the main heat exchanger also if the circulation across the c/h system is completely closed.

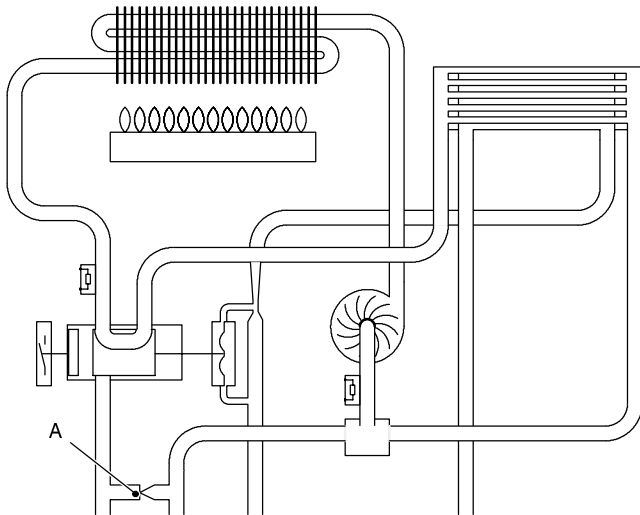

fig. 69

15.2 Removal

Warning: isolate the boiler from the mains electricity supply before removing any covering or component.

- 1 remove the front panel of the case and lower the instrument panel
- 2 empty the main circuit and the d.h.w. circuits of the boiler.

- 3 Remove the hydraulic actuator B (fig. 70) as explained in the section *Diverter valve and d.h.w. pressure switch* of this manual.
- 4 Remove the fork C and the pipe D.



fig. 70 (rear view of the boiler)

- 5 Unscrew the connector E and remove the by-pass valve F (fig. 71).

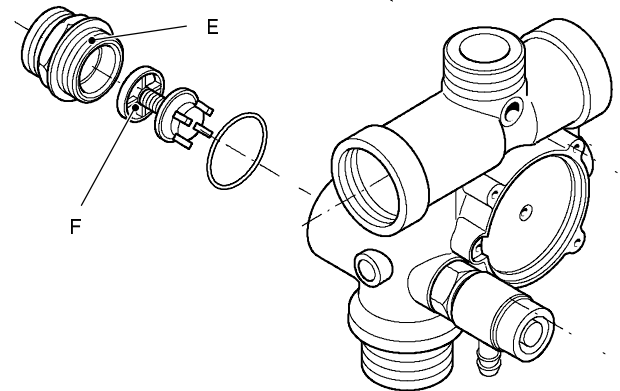

fig. 71

- 6 Reassemble the by-pass valve as illustrated in fig. 71 and proceeding in reverse order.

16 Flue fan, venturi, air pressure switch

16.1 Function

The boiler has a fan whose function is that of forcing the expulsion of the products of combustion.

The fan is supplied by the full sequence ignition device at the beginning of the ignition cycle.

Its correct functioning is controlled by means of a system of a built in venturi device and an air pressure switch.

16.2 Checks

✓ Check of the fan

⚡ **Warning: isolate the boiler from the mains electricity supply before removing any covering or component.**

Remove the front panel of the body and the lid of the sealed chamber.

Disconnect the connectors A (fig. 72) and measure the electrical resistance of the motor that has to be about 47 Ω.

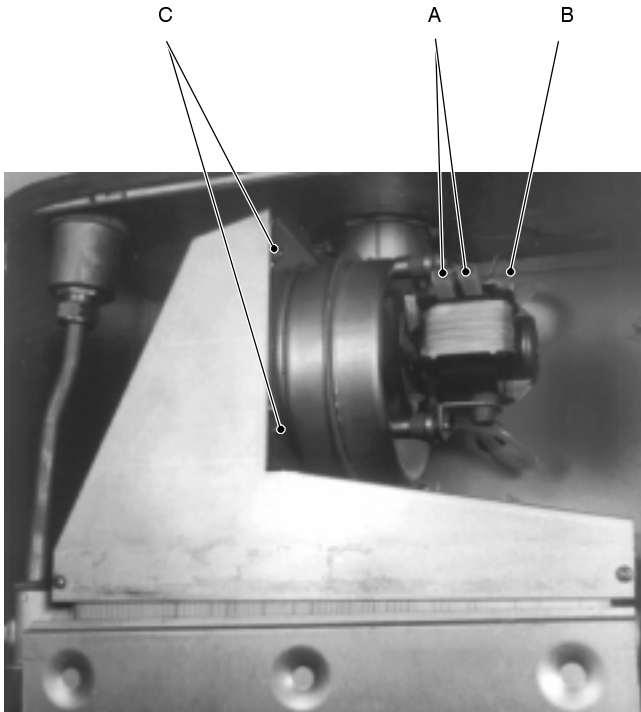

fig. 72

✓ Check of the air pressure switch operation

⚡ **Warning: isolate the boiler from the mains electricity supply before removing any covering or component.**

- 1 Remove the front panel of the body and the lid of the sealed chamber
- 2 Disconnect the wires and check the electrical resistance between its connections

Between COM and NO the contact must be open.

Between COM and NC the contact must be closed (electrical resistance zero).

Refer to the fig. 73a b or c in accordance with the type of air pressure switch used.

These switches are interchangeable.

- 3 Connect the black wire (COM) and the brown wire (NC).
 - 4 Run the boiler (the fan must run) and check the the electric resistance between COM and NO
- Between COM and NO the contact must be closed (electrical resistance zero)

Remember that in this condition the boiler runs only for the ignition safety time and than it goes on safety lock-out. The above described test has to be carried out during this period.

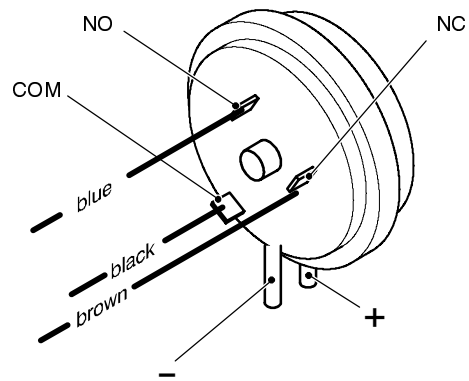

fig. 73a

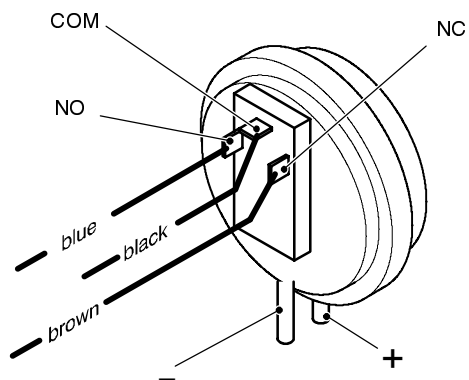

fig. 73b

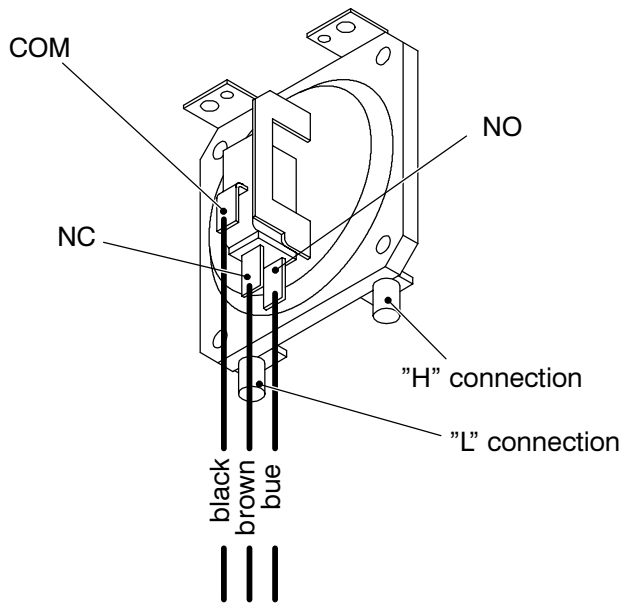

fig. 73c

16.3 Removal of the fan

Warning: isolate the boiler from the mains electricity supply before removing any covering or component.

- 1 Remove the front panel of the body and the lid of the sealed chamber;
- 2 disconnect the connectors *A* and the earth connection *B* (fig. 72);
- 3 disconnect pipes which connect the venturi device to the air pressure switch;
- 4 unscrew the screws *C* and extract it from the exhaust flue duct than move it towards the front of the boiler;
- 5 remove the fan;
- 6 assemble the fan carrying out the removal operations in reverse sequence.

Warning: reassembling the fan, refer to fig. 74 to connect correctly the venturi device to the air pressure switch.

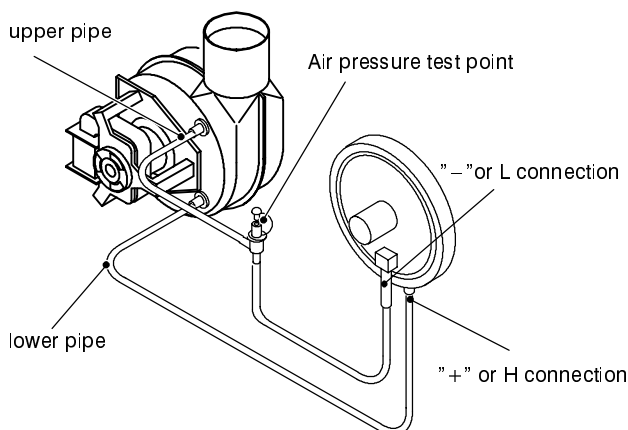

fig. 74

16.4 Removal of the air pressure switch

Note that there are two different air pressure switches with different operating values for the 24S–SR and 28S boilers.

Refer to the short spare parts list for the correct selection of the switch.

Warning: isolate the boiler from the mains electricity supply before removing any covering or component.

- 1 Remove the front panel of the body and the lid of the sealed chamber;
- 2 Disconnect the wires of the air pressure switch;
- 3 Remove the two pipes from the air pressure switch;
- 4 Unscrew the screw *D* (two for the pressure switch of fig. 73c) which holds the air pressure switch to the frame (fig. 75);

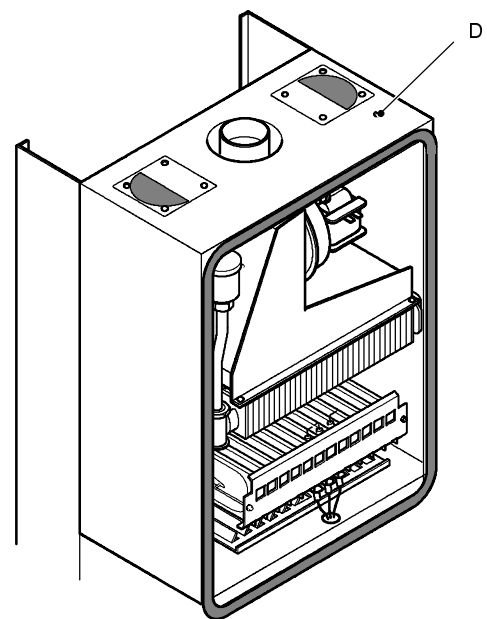

fig. 75

Warning: reassembling the air pressure switch, refer to fig. 73a b or c to connect correctly the wirings and to fig. 74 to connect the venturi device to the air pressure switch.

17 Ignition and detection electrodes

17.1 Function

Three electrodes are fitted on the burner. Two of them are the ignition electrodes and are fitted near the front part of the burner. The ignition sparks take place between their metallic edges over the central ramp of the burner during the ignition sequence.

The third electrode is the detection electrode and it detects the presence of the flame.

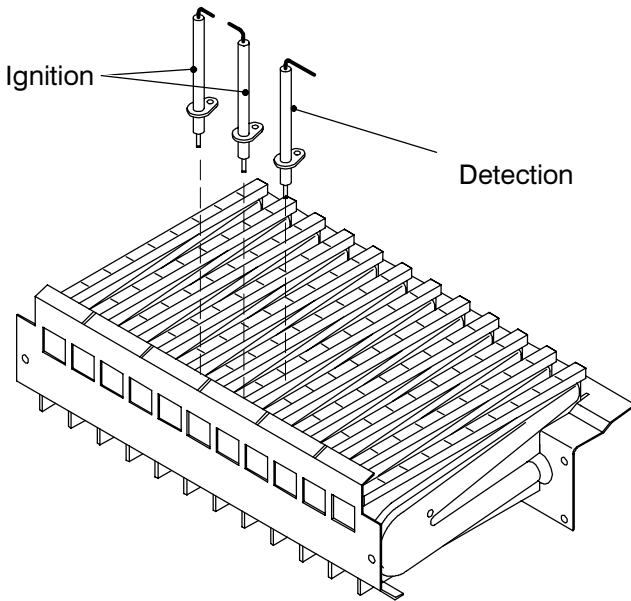

fig. 76

17.2 Checks

✓ Check the position of the electrode edges

⚡ **Warning: isolate the boiler from the mains electricity supply before removing any covering or component.**

Remove the front panel of the body, the sealed chamber cover and the combustion chamber panel.

Check for the correct distance between the metallic edges of the ignition electrodes and refer it to the fig. 77.

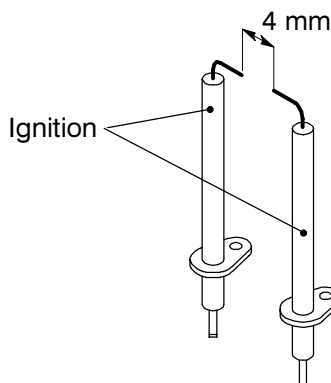

fig. 77

Check the integrity of the detection electrode and ensure that its metallic edge is correctly placed over the ramp of the burner.

✓ Check the connection wires

⚡ **Warning: isolate the boiler from the mains electricity supply before removing any covering or component.**

Remove the front panel of the body, the lid of the sealed chamber and the cover of the combustion chamber.

Check for the integrity of the insulation of wires which connect the electrodes to the ignition device.

17.3 Removal

- 1 Remove the front panel of the body, the sealed chamber lid and the combustion chamber panel.
- 2 Remove the burner unscrewing the four screws placed at the right and left sides of the burner.
- 3 Remove the grid unscrewing the two screws placed on the rear side of the burner.
- 4 Unscrew the screws A (fig. 78) which hold the electrodes to the burner.

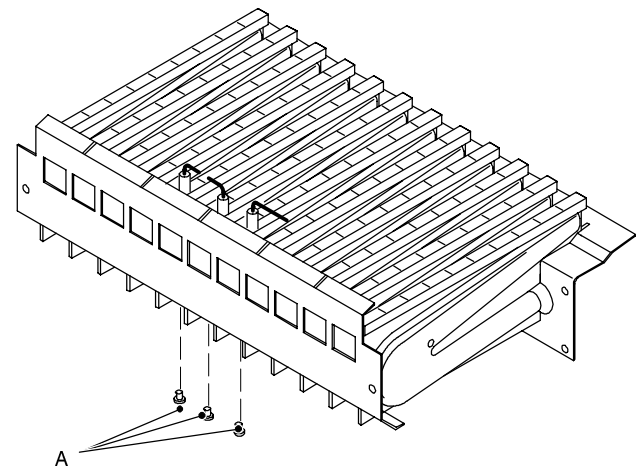

fig. 78

- 5 Extract the electrodes from the burner.
- 6 disconnect the electrode wires from the full sequence ignition device.
- 7 Assemble the electrodes carrying out the removal operation in reverse order.
In order to recognize the electrodes refer to fig. 76.

Note: the metallic edge of the detection electrode is longer than the one of the ignition electrodes.

18 Safety thermostat

18.1 Function

The safety thermostat (A in fig. 79) is a device that senses the temperature of the main circuit water which flows in the outlet pipe of the main heat exchanger.

If the temperature control system of the boiler fails and the temperature of the main circuit reaches a dangerous temperature, the safety thermostat opens the electric circuit which supply the full sequence ignition device.

Consequently, the gas valve operators are no more activated and the gas flow to the burner is stopped.

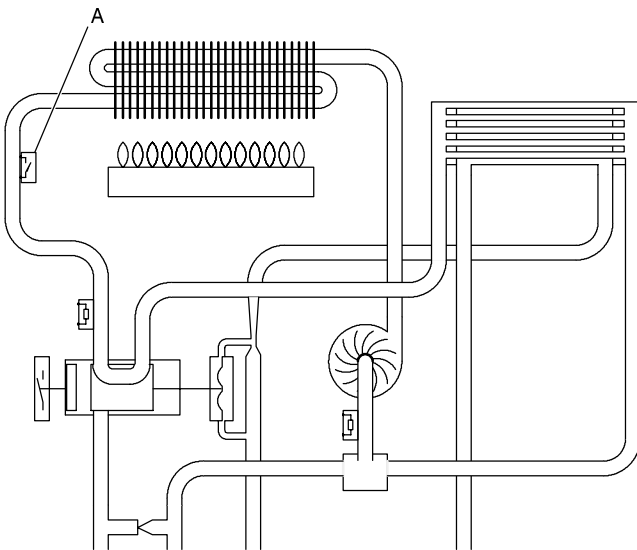

fig. 79

The safety thermostat does not re-set automatically. To reset, it is necessary to push the button B with the help of a tool on the instrument panel (fig. 80).

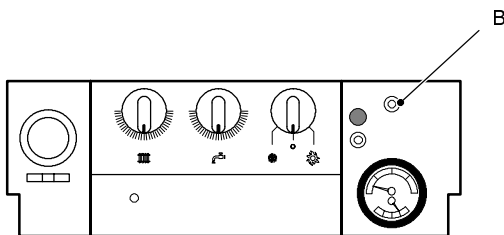

fig. 80

The safety thermostat has two parts:

- the temperature probe C which is fitted on the outlet pipe of the main heat exchanger (fig. 81)

and the electric switch D which is fitted in the instrument panel (fig. 82)

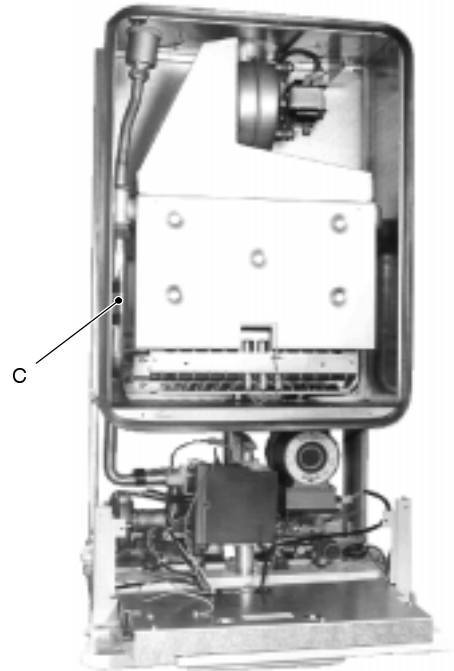

fig. 81

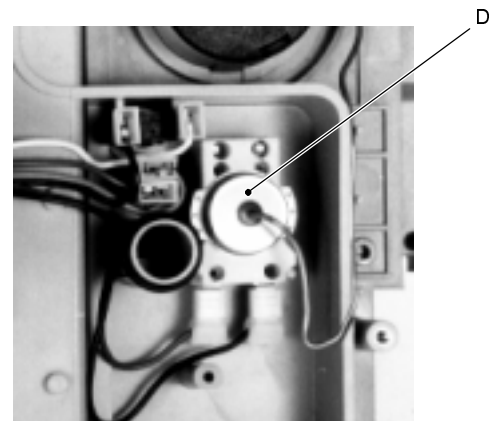

fig. 82

18.2 Checks

⚡ **Warning:** isolate the boiler from the mains electricity supply before removing any covering or component.

✓ Position of probe and integrity

Remove the front panel of the case and the sealed chamber cover.

Verify the soundness of the fitting between the main circuit pipe and the temperature probe C (fig. 81).

Verify the integrity of the capillary which connects the probe to the switch. If the capillary is broken the switch opens automatically.

✓ Overheat temperature value

Set the temperature control knobs to their max. position and run the boiler in d.h.w. and c/h. Allow the boiler to reach its maximum operating temperature (monitor the

temperature gauge on the instrument panel). The boiler should operate and maintain a temperature below that of the safety thermostat and no overheat intervention should occur.

It is not permissible to change the factory setting of the safety thermostat. The safety thermostat must be replaced if its operation temperature is too low and therefore constantly interrupts the correct functioning of the boiler and not allowing it to reach its maximum permissible operating temperatures.

✍ Electrical function

Remove the rear lid of the instrument panel (see chapter *access to and emptying hydraulic circuits*).

Disconnect the switch and check its electrical function. Normally (no intervention) the contact must be closed (electrical resistance zero Ω).

18.3 Removal

- 1 Remove the front panel of the body and the sealed chamber cover.
- 2 Remove the springs which hold the temperature probe and extract the probe from the sealed chamber
- 3 Remove the rear lid of the instrument panel (see chapter *access to and emptying hydraulic circuits*) section 2.4;
- 4 Disconnect the switch
- 5 From the front side of the instrument panel remove the protective cap, unscrew the nut which holds the switch and remove it.
- 6 Reassemble the switch carrying out the operations in reverse order.

19 Short spare parts list

Key	G.C. part no.	Description	Q.ty	Manufacturer part no.	Manufacturer's reference
1	E01 167	13 ramps burner (mod. 24)	1	BG1003 101	Polidoro
	E01 224	15 ramps burner (mod. 28)	1	BG1013 105	
2	E01 155	Injectors for natural	15	BG1013 502	
	E01 156	Injectors for LPG	15	BG1013 501	
3	E01 161	Gas valve	1	BG1013 108	Honeywell VK4105 M 2014
4	E00 690	Expansion vessel	1	BG1012 110	Zilmet 305008
5	E00 691	Main heat exchanger (mod. 24)	1	BG1002 102	
	E01 218	Main heat exchanger (mod. 28)	1	BG1002 103	
6	E01 199	Fan (mod. 24)	1	BG1016 108	LN Natalini A30 CO009
	E01 240	Fan (mod. 28)	1	BG1016 109	LN Natalini B25 CO009
7	E01 185	Air pressure switch (mod. 24)	1	BG1016 106	LN Natalini Type M 1,4 mbar Honeywell C6065 1,4 mbar*
	E01 232	Air pressure switch (mod. 28)	1	BG1016 105	LN Natalini Type M 1,6 mbar Honeywell C6065 1,6 mbar*
8	379 085	Safety valve	1	BG1001 112	Caleffi 512 1/2"
9	E01 189	Combustion chamber panels (mod. 24)	1	BG1006 503	
	E01 234	Combustion chamber panels (mod. 28)	1	BG1006 502	
10	E01 175	Electronic regulation p.c.b.	1	BG1015 108	
11	E01 172	Full sequence control device	1	BG1015 501	Honeywell S4565DD
12	E01 204	D.h.w. heat exchanger (mod. 24)	1	BG1001 101	
	E01 205	D.h.w. heat exchanger (mod. 28)	1	BG1001 102	
13	114 988	Pump	1	BG1002 101	Myson CP53 Salmson MYE 30-15 C-H*
	E00 699	Pump (high head)	1	BG1901 104	Myson CP63 Salmson MYL 50-15 CH3-K*
14	E00 684	Flow switch (main or d.h.w. circuit)	1	BG1011 105	
15	E01 217	D.h.w. flow switch membrane	1	BG1011 102	
16	E00 688	Main. flow switch membrane	1	BG1011 103	
17	379 086	Overheat thermostat	1	BG1015 111	Firt STB/901
18	169 083	Fuse 1,6 A T	1	BG1005 105	
19	164 026	Temperature probe (main or d.h.w. circuit)	1	BG1001 117	
20	E01 042	Automatic air release valve	1	BG1002 111	Caleffi 502040 Minical
21	E01 164	Ignition electrode (left)	1	BG1013 104	
22	E01 165	Ignition electrode (right)	1	BG1013 103	
23	E01 166	Detection electrode	1	BG1013 102	
24	379 087	Reset button	1	BG1015 107	
25	379 088	Shut down warning light	1	BG1015 109	
26	169 096	Temperature-pressure gauge	1	BG1005 501	

* alternative

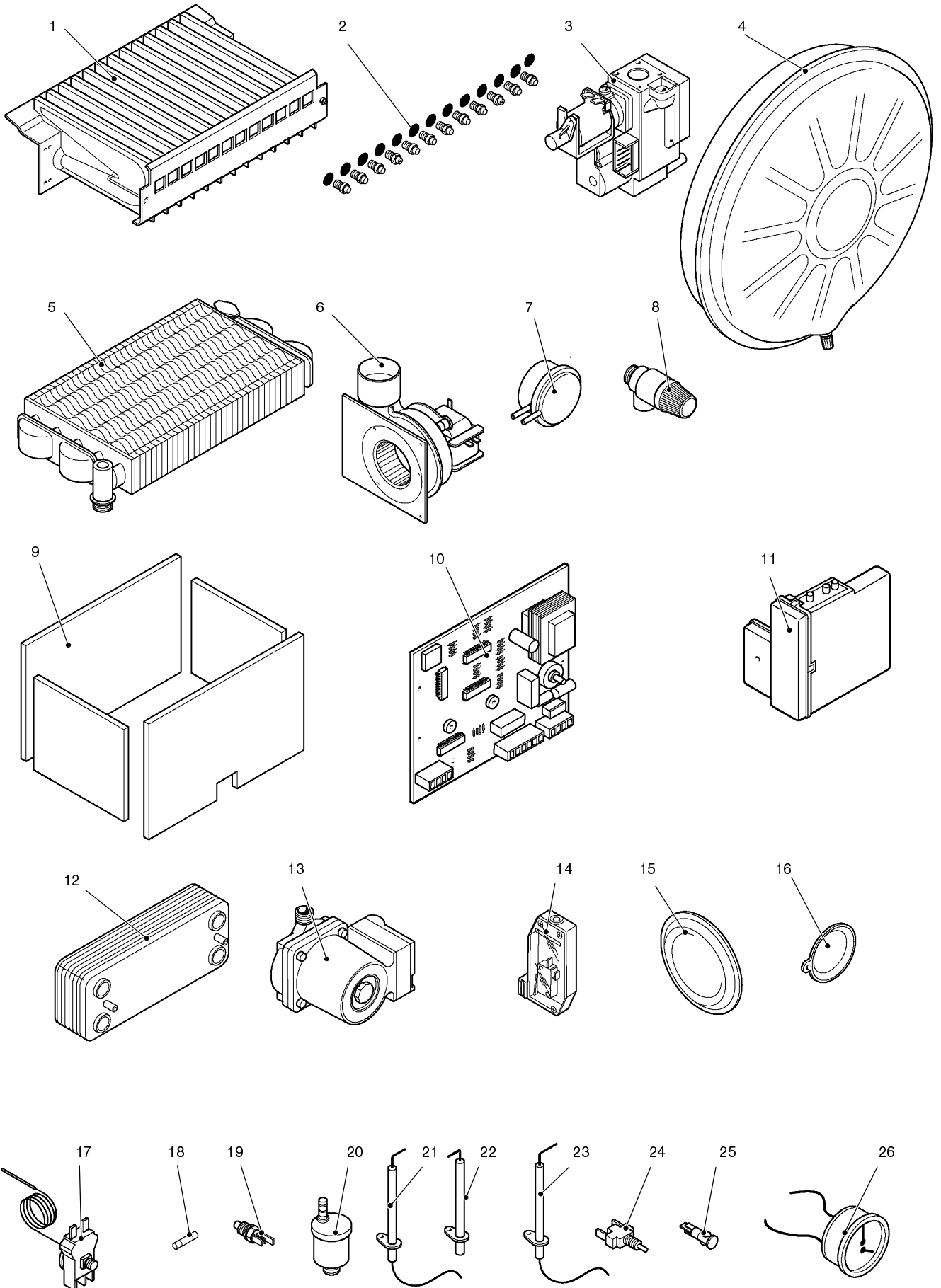



17962.0499.2 (9711)