

# Instructions for Use Installation and Servicing

To be left with the user

# 23c

## Fanned Flue Combination Boiler

G.C. No. 47-047-18



The mark of quality for domestic heating

This is a Cat I<sub>2H</sub> Appliance



10139

optional electro mechanical clock timer shown fitted

*The instructions consist of three parts, User, Installation and Servicing Instructions, which includes the Guarantee Registration Card. The instructions are an integral part of the appliance and must, to comply with the current issue of the Gas Safety (Installation and Use) Regulations, be handed to the user on completion of the installation.*

## Guarantee Registration

Thank you for installing a new Glow-worm appliance in your home.

Glow-worm appliances' are manufactured to the very highest standard so we are pleased to offer our customers' a Comprehensive Guarantee.

This product is guaranteed for 24 months from the date of installation or 30 months from the date of manufacture, whichever is the shorter, for parts. In addition this product is guaranteed for 12 months from the date of installation or 18 months from the date of manufacture, whichever is the shorter, for labour.

The second year of the parts guarantee, from the beginning of the 13th month onwards after installation or manufacture, is conditional upon the boiler having been serviced by a CORGI registered gas installer, in accordance with the manufacturer's recommendations. We strongly recommend regular servicing of your gas appliance, but where the condition is not met, any chargeable spare parts or components issued within the applicable guarantee period still benefit from a 12 month warranty from the date of issue by the manufacturer.

We recommend you complete and return as soon as possible your guarantee registration return literature, supplied in the document envelope.

If your guarantee registration return literature is missing you can obtain a copy or record your registration by telephoning the Heatcall Customer Service number 01773 828100.

REGISTER YOUR GLOW-WORM APPLIANCE

**CALL 0208 247 9857**

**HEATCALL**

Customer Services:

Tel: (01773) 828100

**One Contact Local Service** Fax: (01773) 828070

**Hepworth Heating Ltd.,**

Nottingham Road, Belper, Derbyshire. DE56 1JT

**General/Sales enquiries:**

Tel: (01773) 824141 Fax: (01773) 820569

## Important Information

### Testing and Certification

This boiler is tested and certificated for safety and performance. It is therefore important that no alteration is made to the boiler, without permission, in writing, from Hepworth Heating Ltd.

Any alteration not approved by Hepworth Heating Ltd., could invalidate the certification, boiler warranty and may also infringe the current issue of the Statutory Requirements. The requirements are: The installation of this boiler must be carried out by a competent person in accordance with the current rules in force in the countries of destination at the time of installation. Manufacture's instructions supplied. Manufacture's instructions must not be taken as overriding statutory requirements.

**Note:** The boiler serial number is marked on the label attached to the inside of the drop down door. Refer to the 'Introduction' section for a description of the basic functions of the boiler. The 'Users' section describes how to safely operate the boiler.

### Mandatory warning for CEE countries

**Warning:** This appliance is designed, approved and inspected to meet the requirements of the market. The identification plate located on the inside of the appliance **certifies the origin** where the product was manufactured and the **country** for which it is intended.

If you see any exception to this rule, please contact your nearest **Glow-worm** dealer.

Thank you in advance for your assistance.

### CE Mark

This boiler meets the requirements of Statutory Instrument No. 3083 The boiler (Efficiency) Regulations, and therefore is deemed to meet the requirements of Directive 92/42/EEC on the efficiency requirements for new hot water boilers fired with liquid or gaseous fuels.

Type test for purposes of Regulation 5 certified by: Notified body 0063.

Product/production certified by: Notified body 0063.

The CE mark on this appliance shows compliance with:

1. Directive 90/396/EEC on the approximation of the laws of the Member States relating to appliances burning gaseous fuels.
2. Directive 73/23/EEC on the harmonization of the Laws of the Member States relating to the electrical equipment designed for use within certain voltage limits.
3. Directive 89/336/EEC on the approximation of the Laws of the Member States relating to electromagnetic compatibility.

### Substances Hazardous to Health

Under section 6 of the Health and Safety at Work Act 1974, we are required to provide information on substances hazardous to health.

The adhesives and sealants used in this appliance are cured and give no known hazard in this state.

INSULATION PADS/CERAMIC FIBRE, GLASSYARN, MINERAL WOOL

These can cause irritation to skin, eyes and the respiratory tract.

If you have a history of skin complaint you may be susceptible to irritation. High dust levels are usual only if the material is broken.

Normal handling should not cause discomfort, but follow normal good hygiene and wash your hands before eating, drinking or going to the lavatory.

If you do suffer irritation to the eyes or severe irritation to the skin seek medical attention.

The insulation is composed of non-combustible material.

### Spare Parts

REMEMBER, When replacing a part on this appliance, use only spare parts that you can be assured conform to the safety and performance specification that we require. Do not use reconditioned or copy parts that have not been clearly authorised by Hepworth Heating Ltd.

### Manual Handling Guidance

During the appliance installation it will be necessary to employ caution and assistance whilst lifting as the appliance exceeds the recommended weight for a one man lift.

In certain situations it may be required to use a mechanical handling aid.

Take care to avoid trip hazards, slippery or wet surfaces.

## Contents

CONTENTS	DESCRIPTION	SECTION	PAGE No.
<b>INSTRUCTION FOR USE</b>	Important Information		2
	Introduction		4
	Controls and Lighting		4
	Clock-timer (Optional)		6
	Draining		6
	Safety Devices		7
	Servicing and Maintenance		7
<b>INSTALLATION INSTRUCTIONS</b>	Technical Data	1	8
	Dimensions	2	9
	Heating System Design	3	10
	Domestic Hot Water System Design	4	10
	Boiler Schematic	5	11
	Boiler Location, flue and ventilation	6	12
	Fixing jig pack	7	13
	Piping System Installation	8	14
	Boiler installation	8	15
	Flue Installation telescopic and standard	10	16
	Electrical Connection	11	19
	Commissioning	12	20
	Settings	14	22
<b>SERVICING INSTRUCTIONS</b>	Routine Cleaning and Inspection	15	22
	Fault Finding	16	27
	Wiring Diagram	17	34
	Replacement of Parts	18	35
	Spare Parts	19	44

## Introduction

The 23c boiler is a wall mounted modulating combination boiler with electronic ignition providing central heating and instantaneous hot water.

The boiler is of the **I2H** category for use with Natural Gas (G20) as distributed in the United Kingdom.

The boiler has a fan assisted balanced flue which both discharges the products of combustion to and draws the combustion air from the outside of the room.

The boiler is suitable for top outlet flue connection only but can be fitted with horizontal flue, vertical flue or twin-pipe flue. Refer to flue options guide for further information, this is available from your nearest stockist.

Both the central heating and domestic hot water temperature are user adjustable from the boiler control panel.

Domestic hot water demand always has priority over heating demand.

The pump, expansion vessel and associated safety devices are all fitted within the boiler.

The boiler can be installed against either an external wall or on an adjacent inside wall, that is, the flue system will pass directly to the rear or to either side to the terminal fitted on the outside wall face.

The installation must be carried out by a qualified registered person in accordance with the relevant requirements of The Building Regulations, The Water Byelaws, The Building Standards (Scotland) Regulations and any applicable local regulations.

These instructions should be carefully followed for the safe and economical use of your boiler.

### Electrical Supply

**WARNING:** This boiler must be earthed.

All system components shall be of an approved type and shall be connected in accordance with the current issue of BS7671 and any applicable local regulations.

All external wiring between the appliance and the electrical supply and earthing requirements shall comply with the current IEE Regulations.

Connection of the boiler and system controls to the mains supply must be through a common isolator and must be fused 3A, maximum. This method of connection must be by a fused double pole isolating switch, with a minimum contact separation of 3mm on both poles. The switch should be readily accessible

and preferably adjacent to the appliance. It should supply the appliance only and be easily identifiable as so doing.

Alternatively, an unswitched shuttered socket outlet and 3A fused 3 pin plug, both to the current issue of BS1363 may be used provided that they are not used in a room containing a bath or shower.

Wiring to the boiler must be PVC 85°C insulated cable, not less than 0.75mm<sup>2</sup> (24/0.20mm).

### Gas safety (Installation and use) Regulations

In your interests and that of gas safety, it is the law that ALL gas appliances are installed and serviced by a qualified registered person in accordance with the above regulations.

### Gas leak or fault

If a gas leak or fault exists or is suspected, turn the boiler off and consult the local gas supply company or your installation/service company.

### Air in the heating system

Persistent air in the heating system may indicate leaks in the system or corrosion taking place. Call your Installation/Service company.

### Overheating safety

In the event of a problem, the overheating safety devices cause safety shutdown of the boiler. If this happens, call your Installation/Service company.

### Boiler controls

The control panel, located at the lower front of the boiler casing, **see diagram 1**, allows the boiler to be started, shut down, controlled and monitored during use.

### Flue

Do not obstruct the outside terminal of the flue.

### Ancillary equipment

A range of flue accessories are available including vertical flues, twin-pipe flues, bends etc.

For further information contact your supplier.

## Controls and lighting

Your 23c boiler has been factory configured to operate at the heart of an existing installation. However, because many installations are specially designed, do not hesitate to contact your installer who will be able to ensure that you get the best performance from your installation, by adjusting the heating circuit's maximum output or temperature.

Once these settings have been made, you can still adjust the temperature to suit your needs.

### Central heating adjustment

The selector switch enables you to vary the temperature of the water in the central heating circuit from the minimum setting (approx. 38°C) up to the maximum temperature set by your installer. Most of the time, the mid position will meet your needs but the selector should be moved nearer to the maximum setting in very cold weather when your home is not reaching the required temperature.

### Domestic hot water

The selector switch can be adjusted from a temperature of (approx. 35°C up to 60°C or more).

The **ECO** setting is ideally suited for all the requirements of normal family use (showers, washing up etc.). The maximum setting should be reserved for occasional use when very hot water is required.

## Controls and Lighting

- 1 - On/Off switch
- 2 - Central heating temperature selector
- 3 - Domestic hot water temperature selector
- 4 - Pressure gauge (bar) and temperature gauge (°C)
- 5 - Fault display (faults indicated by a red flashing light)
- 6 - Clock-timer (Optional)

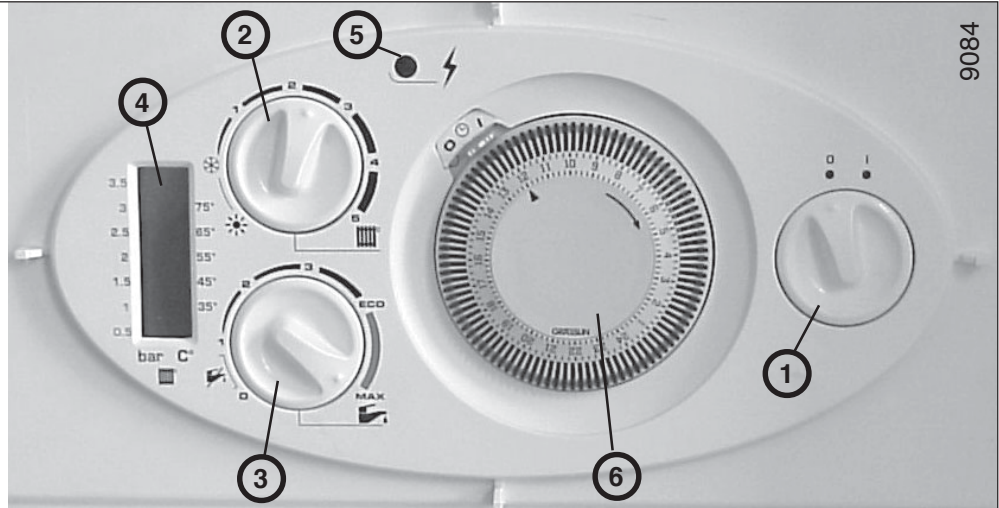

Diagram 1

### 1. Lighting the boiler :

#### Make sure that:

- The boiler is connected to the electrical supply.
- The gas service cock is open.

Turn the switch **ON ( I )**



### 2. Stop the boiler :

- Turn the switch **OFF ( 0 )** the electrical supply is OFF.
- Turn the gas supply OFF at the gas service cock if the boiler is to be out of use for a long time.

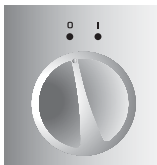

### 3. Domestic hot water adjustment :

- **Position ( 0 )**: Domestic hot water OFF
- **Position ( I ) and ECO**: Domestic hot water between approx. 35°C and 50°C
- **ECO**: Maximum recommended for constant use
- **Between ECO and maxi**: Occasional use for water above approx. 50°C

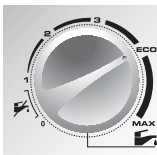

### 4. Heating temperature adjustment :

- **Winter**: Set the control knob between ❄️ 1 and 5
- **Summer**: Set the control knob to ☀️



### 5. If a fault occurs (indicated by red flashing light) :

- **Reset boiler**: Turn the On/Off switch to ( 0 ), wait for five seconds. Turn the On/Off switch to ( I ) the boiler is reset. If the fault continues call your Installation/Service company or Heatcall. (Glow-worm's own service organisation) using the telephone number on the front cover of this literature.



### 6. Installation filling :

- **If the boiler loses water**: the pressure gauge (a) and fault display (b) will flash. Fill the system by the filling device (c) at the bottom of the boiler until the pressure gauge reads 1.5 bar.

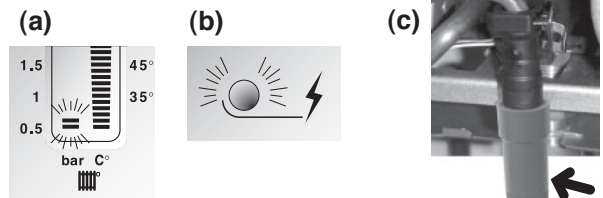

- **Warning**: Take care not to overfill the boiler. At a pressure of 2.5 bar or above indicating over pressure, the fault display (b) will flash. The pressure must be reduced to 1.5 bar by bleeding a radiator. If the fault continues call your Installation/Service company or Heatcall. (Glow-worm's own service organisation) using the telephone number on the front cover of this literature.

Diagram 2

## Clock-timer instructions for use

**Optional Clock-timers inclusive of installation and user instructions:-** These are available from your nearest stockist.

**Electro/Mechanical Part No. 4000122022**

**Digital Part No. 4000120494**

## Draining

### Protection against freezing

The boiler has a built in frost protection programme as long as the electricity and gas are left switched on.

If the temperature within the appliance falls to 3°C the burner and system pump are activated.

When the temperature inside the appliance reaches 10°C the burner will shut down and after a short period the pump will stop.

This device primarily protects the boiler. Any other exposed areas of the system should be protected by a separate frost thermostat.

If the boiler is to be out of use for any long periods during severe weather conditions, it is recommended that the whole system, including the boiler, be drained to avoid the risk of freezing.

If in doubt, consult your servicing company.

### Draining and filling

**Caution:** The boiler is installed as part of a sealed system which must only be drained and filled by a competent person.

## Safety Devices

The 23c incorporates a visual fault display that indicates certain fault conditions, (red flashing light) should they occur.



Should the boiler fail to operate during Commissioning, the most likely fault is that the gas supply to the boiler has not been turned on or purged sufficiently or that there is no pressure in the heating system.

### General safety devices

#### Air flow rate safety device

If an obstruction, even partial, of the flue occurs, for any reason whatsoever, the built in safety system of the boiler will turn the boiler OFF, the red light will flash and the fan will continue to run. The boiler will be ready to operate when the fault has been cleared.

#### Heating safety valve

**CAUTION:** A heating safety valve with a discharge pipe is fitted to this boiler.

The valve **MUST NOT BE TOUCHED** except by a qualified registered person. If the valve discharges at any time, switch the boiler off and isolate it from the electrical supply. Contact your installation/service company.

#### In case of power supply failure

The boiler no longer operates. As soon as power supply is restored, the boiler will be automatically restarted.

#### If the gas supply is interrupted

The boiler switches over to safety mode, the red light will flash. Call a qualified service engineer or Heatcall (Glow-worm's own service organisation) using the telephone on the front cover of this literature.

#### Air in pipes

**Important:** A central heating system can not operate correctly unless it is filled with water and air bled from the system. If these conditions are not met the system may be noisy.

Bleed the air in the radiators and adjust the pressure if system requires. If the system requires filling to often this may be due to minor leaks or corrosion in the system. Call a qualified service engineer or Heatcall (Glow-worm's own service organisation) using the telephone number on the front cover of this literature.

#### Frost protection

The **23c** has a built in frost protection device that protects the boiler from freezing. If the boiler is to be left and there is a risk of frost, ensure that the gas and electrical supplies are left connected. The frost protection device will light the boiler when the temperature of the boiler water falls below 6°C. When the temperature reaches 16°C, the boiler stops.

**Note :** This device works irrespective of any room thermostat setting and will protect the complete heating system.

## Servicing and Maintenance

To ensure the continued efficient and safe operation of the appliance it is recommended that it is checked and serviced as necessary at regular intervals. The frequency of servicing will depend upon the particular installation conditions and usage, but in general once a year should be enough.

If this appliance is installed in a rented property there is a duty of care imposed on the owner of the property by the current issue of the Gas Safety (Installation and Use) Regulations, Section 35.

Servicing/maintenance should be carried out by a competent person in accordance with the rules in force in the countries of destination.

To obtain service, please call your installer or **Heatcall (Glow-worm's own service organisation)** using the telephone number behind the controls cover door.

Please be advised that the 'Benchmark' logbook should be completed by the installation engineer on completion of commissioning and servicing.

All CORGI Registered Installers carry a CORGI ID card, and have a registration number. Both should be recorded in your boiler Logbook. You can check your installer is CORGI registered by calling CORGI direct on: 01256 372300.

#### Cleaning

The boiler casing can be cleaned with a damp cloth followed by a dry cloth to polish.

**Do not use abrasive or solvent cleaners.**

#### Boiler casing

**CAUTION.** Do not remove or adjust the casing in any way, as incorrect fitting may result in faulty operation. If in doubt, consult your installation/service company.

# 1 Technical Data

## Heating

Heat input (max) NET Q	25 kW 85,300 BTU/H
Heat input (min) NET Q	10,4 kW 35,490 BTU/H
Heat output (max) NET P	23 kW 78,480 BTU/H
Heat output (min) NET P	8,7 kW 29,670 BTU/H
Efficiency - Sedbuk D	79,90%
Maximum heating temperature	87° C
Expansion vessel effective capacity	5 l
Expansion vessel charge pressure	0,5 bar
Maximum system capacity at 75°C	110 l
Safety valve, maximum service pressure	3 bar

## Hot water

Heat input (max) NET Q	25 kW 85,300 BTU/H
Heat input (min) NET Q	10,4 kW 35,490 BTU/H
Heat output (max) NET P	23 kW 78,480 BTU/H
Heat output (min) NET P	8,7 kW 29,670 BTU/H
Maximum hot water temperature	63 °C
Minimum hot water temperature	35 °C
Specific flow rate (for 30°C temp rise)	11L/min.
Threshold flow rate	1,7 L/min.
Maximum supply pressure	10 bar
Minimum supply pressure	0,5 bar

## Combustion

Products outlet diameter	60 mm
Fresh air inlet diameter	100 mm
Combustion products values	CO (52 ppm) CO <sub>2</sub> (6,40%) NO <sub>x</sub> (92ppm)

## Electrical

Electrical supply	230 V ~ 50Hz
Electrical rating	122 W fused at 3A
Level of protection	IPX4D
Fuse rating	125mA

## Natural Gas (G20)

Ø Burner injector	1,2 mm
Inlet pressure	20 mbar
Maxi. Burner pressure	12 mbar
Mini. Burner pressure	2 mbar
Gas rate maximum	2,64 m <sup>3</sup> /h

## 1 Technical Data

- 1** Bypass fully shut
- 2** Open 1/4 turn
- 3** Open 1/2 turn
- 4** Open 1 turn
- 5** Open 2 turns

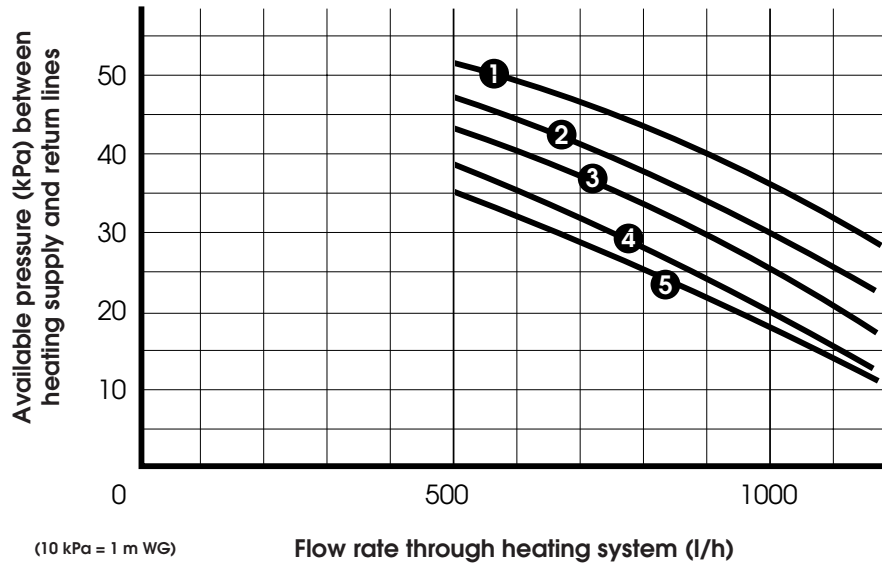

10086

Diagram 1.1

## 2 Dimensions

The 23c is delivered in three separate packages:

- The boiler
- The fixing jig and hanging bracket
- The flue system

**Net lift weight (boiler only) 36 kg**

**Gross lift weight (boiler and packaging) 37 kg**



Optional electro mechanical clock timer shown fitted

Diagram 2.1

## 3 Heating System Design

- The 23c is compatible with any type of installation.
- Heating surfaces may consist of radiators, convectors or fan assisted convectors.
- Pipe sectional areas shall be determined in accordance with normal practices, using the output/pressure curve (**diagram 1.1**). The distribution system shall be calculated in accordance with the output requirements of the actual system, not the maximum output of the boiler. However, provision shall be made to ensure sufficient flow so that the temperature difference between the flow and return pipes be less than or equal to 20°C. The minimum flow is 500 l/h.
- The piping system shall be routed so as to avoid any air pockets and facilitate permanent venting of the installation. Bleed fittings must be provided at every high point of the system and on all radiators.
- The total volume of water permitted for the heating system depends, amongst other things, on the static head in the cold condition. The expansion vessel on the boiler is pressurised at 0.5 bar and allows a maximum system volume of 110 litres for

an average temperature of 75°C and a maximum service pressure of 3 bar. This pressure setting can be modified at commissioning stage if the static head differs. An additional expansion vessel can be fitted to the system if required, see **diagram 8.2**.

- Provision shall be made for a drain valve at the lowest point of the system.
- Where thermostatic radiator valves are fitted, not all radiators must be fitted with this type of valve, and in particular, where the room thermostat is installed.
- In the case of an existing installation, it is **ESSENTIAL** that the system is thoroughly flushed prior to installing the new boiler, using a proprietary product such as Fenox or Sentinel. Contact the product manufacturers for specific details.

### 3.1 Filling the system

A filling device is fitted to the boiler to initially fill the system and replace water lost during servicing, **see the relevant parts of diagram 2 controls and lighting and diagram 8.2**.

## 4 Domestic Hot Water System Design

- Copper tubing or plastic Hep<sub>2</sub>0 may be used for the domestic hot water system. Unnecessary pressure losses should be avoided.
- The flow restrictor must be fitted limiting the flow through the boiler to a maximum of 10 l/min.
- The boiler will operate with a minimum supply pressure of 0,6 bar, but under reduced flow rate.

Best operating comfort will be obtained from a supply pressure of 1 bar.

### 4.1 Hard Water Areas

In areas where the water is 'hard', more than 200mg/litre, it is recommended that a proprietary scale reducer is fitted in the cold water supply to the boiler.

## 5 Boiler Schematic

- |   |   |  |
|---|---|--|
| <ul style="list-style-type: none"> <li>1 - Fan.</li> <li>2 - Air pressure switch.</li> <li>3 - Heat exchanger.</li> <li>4 - Overheat thermostat.</li> <li>5 - Combustion chamber.</li> <li>6 - Expansion vessel.</li> <li>7 - Ignition electrode.</li> <li>8 - Burner.</li> <li>9 - Flame sense electrode.</li> <li>10 - Pump.</li> <li>11 - Heating thermistor.</li> </ul> | <ul style="list-style-type: none"> <li>12 - Ignition module.</li> <li>13 - By-pass.</li> <li>14 - Gas valve.</li> <li>15 - Loss of water sensor.</li> <li>16 - Domestic hot water thermistor</li> <li>17 - Automatic air vent</li> <li>18 - Domestic water flow sensor</li> <li>19 - Filter cold water inlet</li> <li>20 - Filling system</li> <li>21 - Discharge safety valve (3bar)</li> <li>22 - Heating filter</li> <li>23 - Drain valve</li> </ul> | <ul style="list-style-type: none"> <li>A - Heating flow</li> <li>B - Domestic hot water outlet</li> <li>C - Gas</li> <li>D - Cold water inlet</li> <li>E - Heating return</li> </ul> |
|---|---|--|

9720

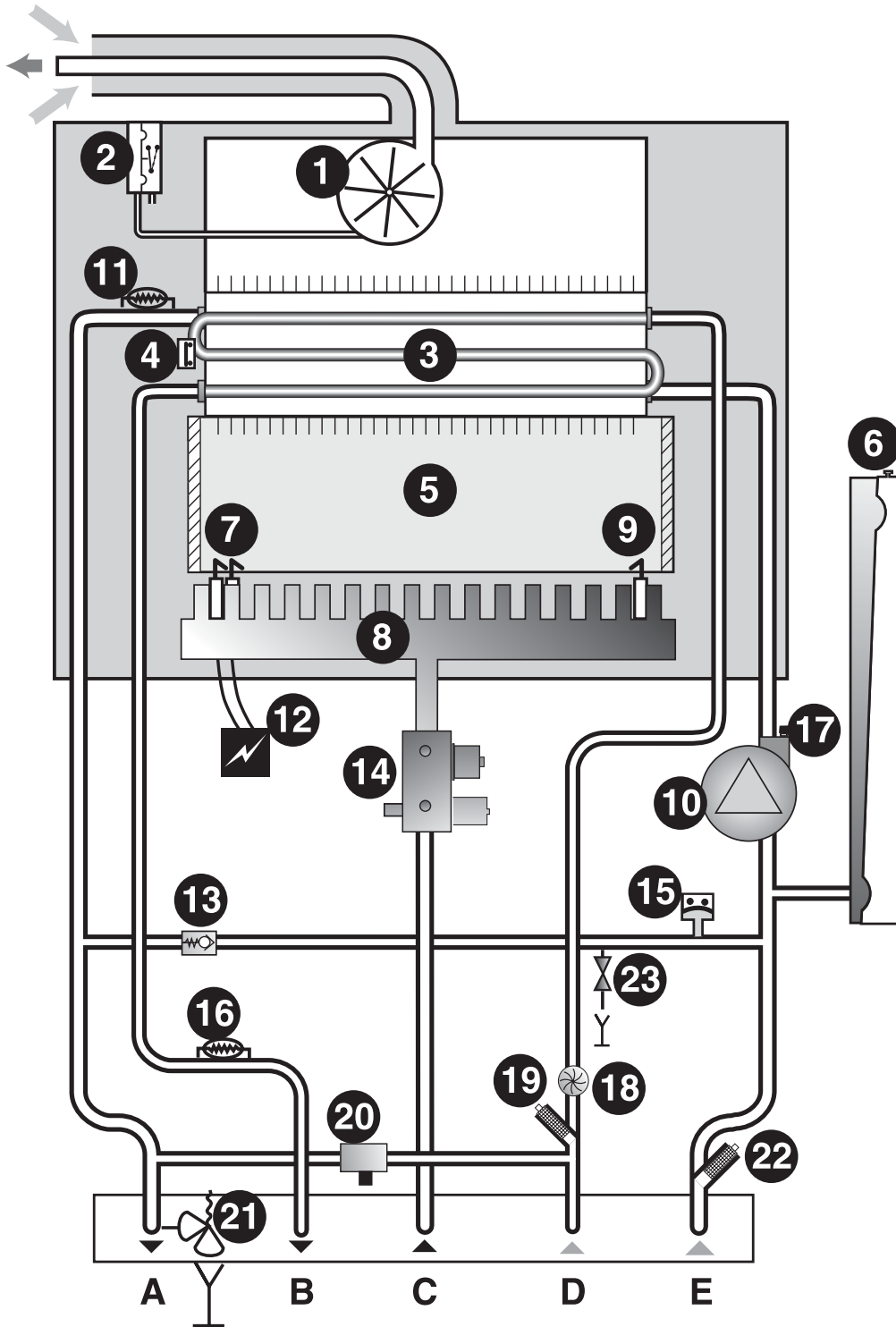

9321

Diagram 5.1

## 6 Boiler Location, Flue and Ventilation

If the appliance has to be stored for any length of time before installation it should be kept in a safe place where it will not be a hazard to persons or obstruct any access.

### 6.1 Clearances

The position of the boiler must be such that there is adequate space for servicing.

The recommended clearances are:

20 mm either side of the boiler.

600 mm at the front of the boiler.

300 mm below the boiler.

25 mm above the flue elbow.

**Note:** The boiler must be mounted on a flat wall which is sufficiently robust to take its weight when full, that is, 36 kg. If in doubt, expert advice should be obtained, in the event of the wall being found not suitable.

**Note:** It is permissible to install the boiler with smaller clearances than those quoted above PROVIDING that adequate consideration is given for Servicing/Repairs at a later date. If any doubt exists, contact the **Glow-worm's Technical Helpline 01773 828300**.

The minimum acceptable spacings from the terminal to obstructions and ventilation openings are shown in **diagram 6.1**.

The boiler must be installed so that the terminal is exposed to the external air.

Should any doubt exist as to the permissible position of the terminal, contact the **Glow-worm's Technical Helpline 01773 828300**.

### 6.2 Terminal guard

A terminal guard is required if persons could come into contact with the terminal or the terminal could be subject to damage.

If a terminal guard is required, it must be positioned to provide a minimum of 50mm clearance from any part of the terminal and to be central over the terminal.

Terminal guard type K3 supplied by:

*Tower flue components Ltd.*  
Morley road  
Tonbridge  
Kent  
TN9 1RA

### 6.3 Flue options

There are various flue systems to choose from as follows:

Telescopic horizontal flue pack, (rear only).

Standard horizontal flue pack, (left or right only).

Standard horizontal extended flue pack, for use with standard horizontal flue pack.

Vertical flue pack.

Twin flue pack.

Extensions, 90° and 45° bends.

Flue options and accessories.

For detailed information refer to flue options guide for further information, this is available from your nearest stockist.

### 6.4 Cupboard or compartment ventilation

The boiler can be fitted in a cupboard or compartment without the need for permanent ventilation.

#### MINIMUM SITING DIMENSIONS FOR THE POSITIONING OF FLUE TERMINALS MM

A	DIRECTLY BELOW, ABOVE OR HORIZONTALLY TO AN OPENING, AIR BRICK, OPENING WINDOWS, AIR VENT, OR ANY OTHER VENTILATION OPENING	300
B	BELOW GUTTER, DRAIN/SOIL PIPE	75
C	BELOW EAVES	200
D	BELOW A BALCONY OR CAR PORT	300
E	FROM VERTICAL DRAIN PIPES AND SOIL PIPES	300
F	FROM INTERNAL CORNERS AND EXTERNAL CORNERS	300
G	ABOVE ADJACENT GROUND OR BALCONY LEVEL	300
H	FROM SURFACE FACING THE TERMINAL	600
I	FACING TERMINALS	1200
J	FROM OPENING (DOOR/WINDOW) IN CAR PORT INTO DWELLING	1200
K	VERTICAL FROM A TERMINAL	1500
L	HORIZONTALLY FROM A TERMINAL	600

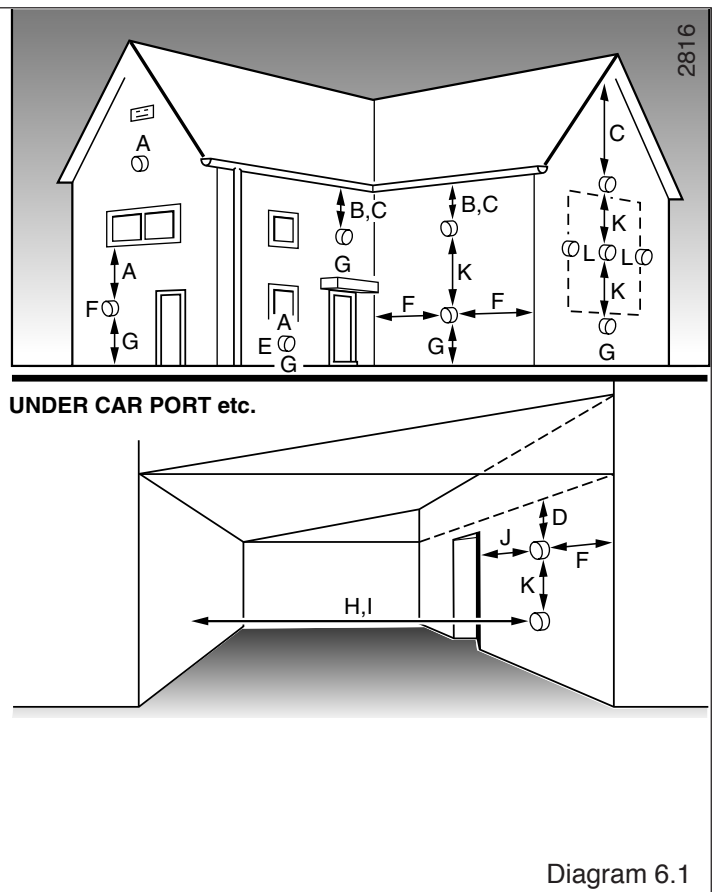

## 7 Fixing Jig Pack

The fixing jig is made up as follows:

- A** - Heating return fitting with isolating valve (v).
- B** - Cold water inlet fitting with isolating valve (m).
- The cold water inlet restrictor supplied with boiler is fitted when the boiler is installed. Refer to Section 9.
- C** - Heating flow fitting with isolating valve (q).
- D** - Domestic hot water outlet.
- E** - Gas fitting.

Other components within the fixing jig pack.

- F** - Hanging bracket
- G** - wall template
- H** - copper connections
- J** - sealing washers and screws

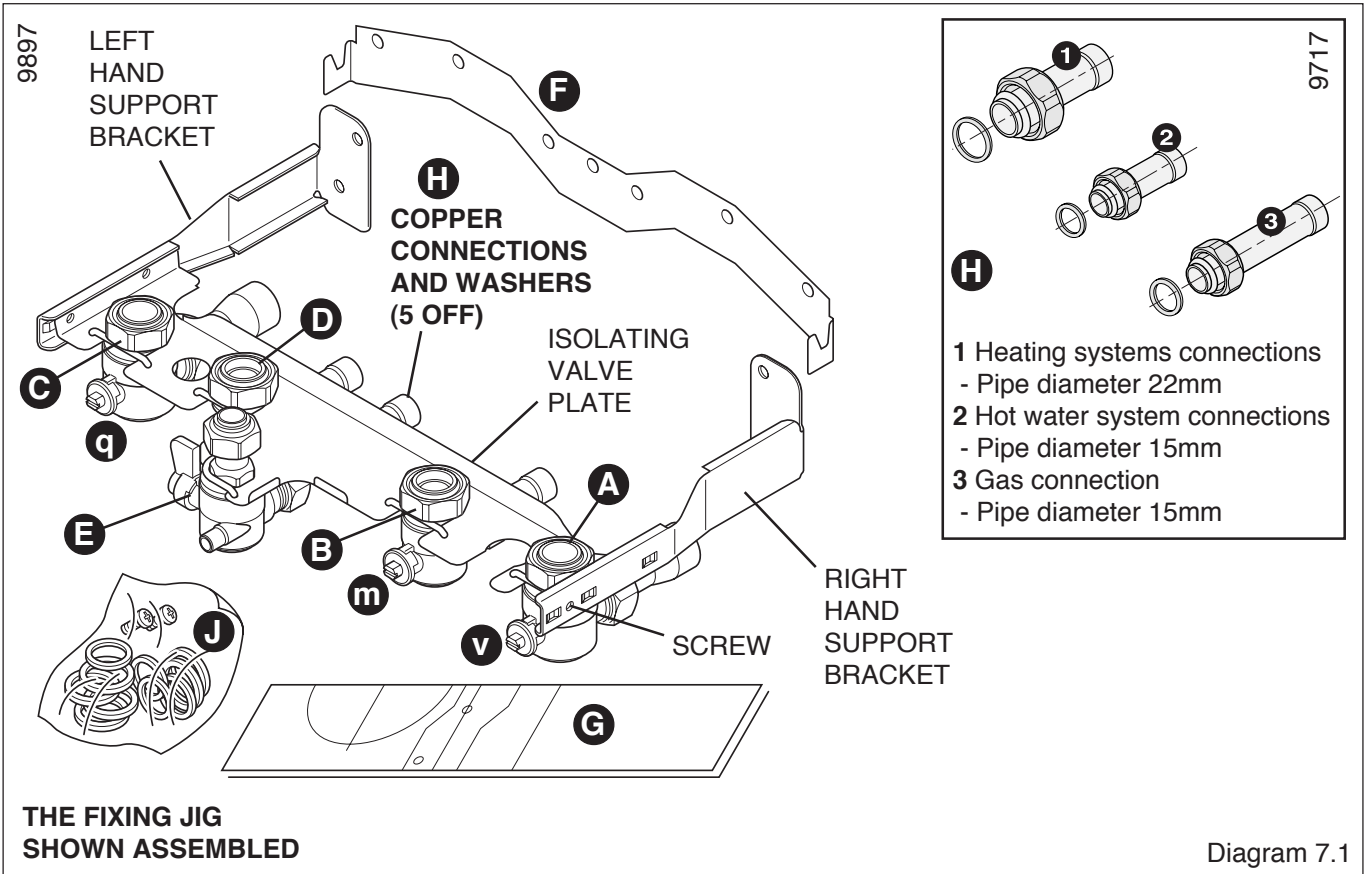

## 8 Piping System Installation

### 8.1 Fixing jig, see diagram 7.1

- Remove the contents of the fixing jig pack.
- Secure the left and right hand support brackets to the isolating valve plate with the securing screws (2 OFF) supplied.
- Connect the five copper connections and sealing washers to the isolating valves.

1 Heating system connections - Pipe diam. 22mm

2 Hot water system connections - Pipe diam. 15mm

3 Gas connection - Pipe diam. 15mm

### 8.2 Wall template

- Remove the wall template, follow the instructions given on the wall template.
- Note: It is important the hanging bracket and service cock bracket are fitted to a flat and true wall area for correct alignment with the boiler. If this cannot be achieved it is acceptable to pack out the service cock bracket to obtain the correct alignment.
- Position the wall template, **see diagram 8.1**.
- Mark the position of the holes for the hanging bracket and jig.
- Drill, plug and fix the hanging bracket to the wall using suitable screws (not supplied).
- Check that the hanging bracket is level.
- Drill plug and fix the fixing jig to the wall.
- For horizontal flue system, mark the position for the flue hole as follows:

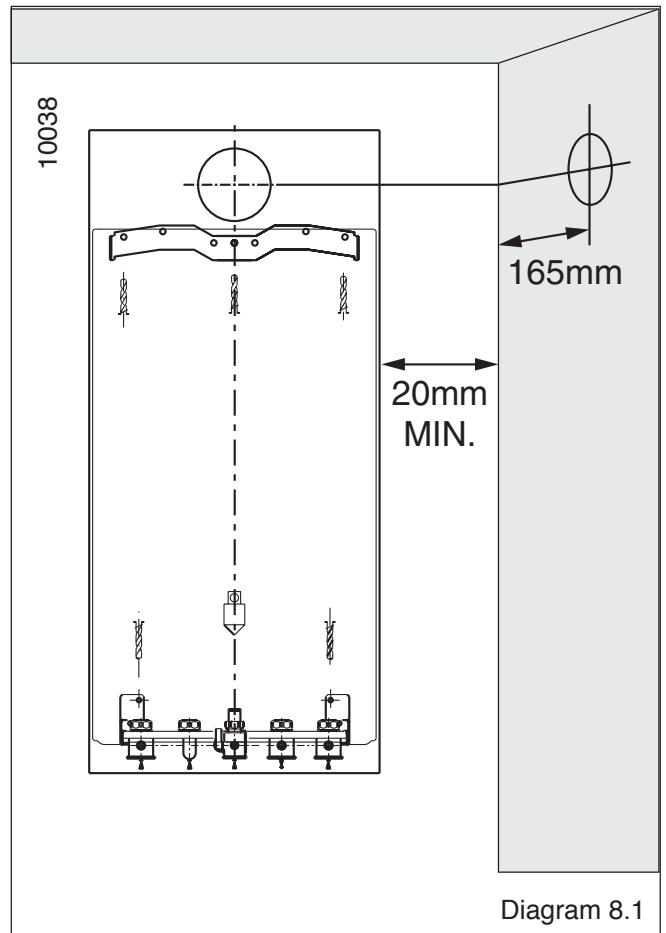

### 8.3 Flue to rear of boiler

- Mark correct position of hole from template.

### 8.4 Flue to side of boiler

- Mark the horizontal centre line for the hole on the rear wall. Extend the horizontal centre line to the side wall and mark the vertical centre line of flue hole as shown in **diagram 8.1**.

### 8.5 Cutting the flue hole

- Making allowance for the slope of the flue, cut hole in external wall, preferably using a core drill. For installations with internal and external access use a 105 mm diameter core drill.

For installations with internal access only use a 125 mm diameter core drill.

### Important

When cutting the flue hole and when extending the flue centre line to a side wall, remember that the flue system must have a fall of about 35 mm per metre of flue DOWNWARD towards the terminal. There must NEVER be a downward incline towards the boiler.

### 8.6 Water connection

Connect the system pipework to the copper connections on the fixing jig observing the correct flow and return format as shown in **diagram 8.2**. Do not subject the isolating valves to heat.

### 8.7 Gas connection

- The supply from the governed gas meter must be of adequate size to provide a constant inlet working pressure of 20 mbar (8 in w.g.).

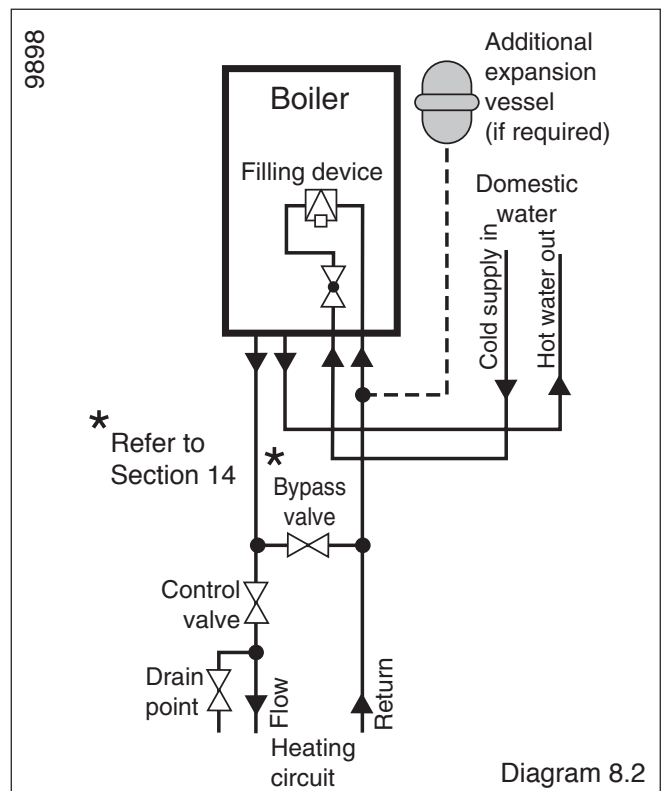

## 8 Piping System Installation

To avoid low gas pressure problems, it is recommended that the 15 mm gas supply on the boiler is connected to using 22 mm pipe (as close as possible to the boiler within 1 metre).

- On completion, the gas installation must be tested using the pressure drop method and purged in accordance with the current issue of BS6891.

## Gas Safety (Installation and use) Regulations

In your interests and that of gas safety, it is the law that ALL gas appliances are installed and serviced by a competent person in accordance with the above regulations.

## 9 Boiler Installation

### 9.1 Statutory requirements

The installation of this boiler must be carried out by a qualified registered person in accordance with the relevant requirements of the current issue of:

The Gas Safety (Installation and Use) Regulations

The Building Regulations

The local water company Byelaws

The Building Standards Regulations (Scotland)

The Health and Safety at Work Act

### 9.2 Sheet metal parts

**WARNING.** When installing or servicing this boiler, care should be taken when handling the edges of sheet metal parts to avoid the possibility of personal injury.

### 9.3 Installing the boiler

Prior to starting work, the system must be thoroughly flushed using a propriety cleanser such as **Sentinel X300** to eliminate any foreign matter and contamination e.g. metal filings, solder particles, oil, grease etc.

**Note.** Solvent products could cause damage to the system.

The boiler pack consists of the boiler and a document envelope and fittings pack which contain, literature, self adhesive wiring diagram label, magnetic user instruction label, external controls connector, guarantee return form, sealing washers, screws, flue restrictor, cold water inlet restrictor, filling loop extension, discharge safety valve pipe.

• **IMPORTANT:** With regards to the manual handling operations, 1992 regulations, the following operation exceeds the recommended weight for one man lift.

- Stand the boiler upright.
- Remove all packaging from around the boiler.
- Remove the transit plate from the fan outlet, on top of the boiler, secured with two screws.
- Remove front panel, unscrew and remove the two retaining screws from the bottom of the front panel. Remove front panel by lifting up and forward.
- If applicable remove the self adhesive wiring diagram label from the document envelope. Fit the self adhesive wiring diagram label to the inside of the front panel, put front panel in a safe place to avoid damaging it.
- Ensure the plastic plugs are removed from water and gas pipes. **NOTE:** There will be some spillage of water.
- Fit water flow restrictor into cold water inlet isolating valve, **see diagram 18.4.**

Lift the boiler up and engage boiler upper part onto the hanging bracket.

- Fit the washers between the boiler pipes and the inlet and outlet fittings on the fixing jig and connect the various couplings between the boiler and jig.

### 9.4 Discharge safety valve, refer to diagram 9.1.

**WARNING.** It must not discharge above an entrance or window or any type of public access area.

A short discharge pipe is supplied in the fittings pack, when fitted to the safety valve it will end below the boiler. The discharge pipe must be extended using not less than 15 mm o.d. pipe, to discharge in a visible position outside the building, facing downward preferably over a drain.

**Note:** Fit a compression fitting to facilitate service of the appliance.

The pipe must have a continuous fall and be routed to a position so that any discharge of water, possibly boiling or steam, cannot create any danger to persons, damage to property or external electrical components and wiring. Tighten all pipe connection joints.

### 9.5 Filling loop extension

Remove the filling loop extension knob from the fittings kit. Fit to the filling device on/off knob this is a push fit, see diagram 9.2.

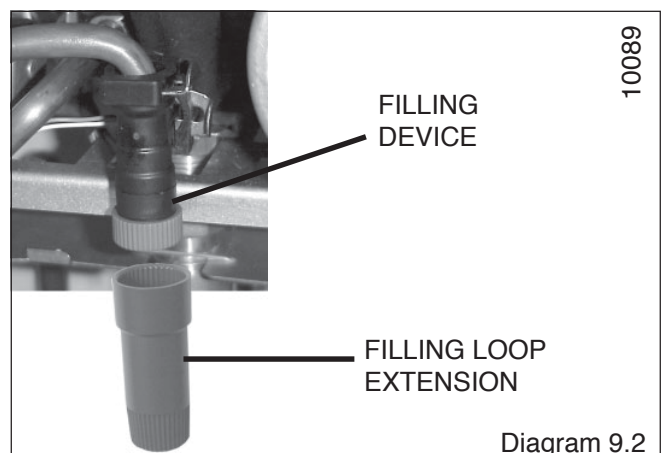
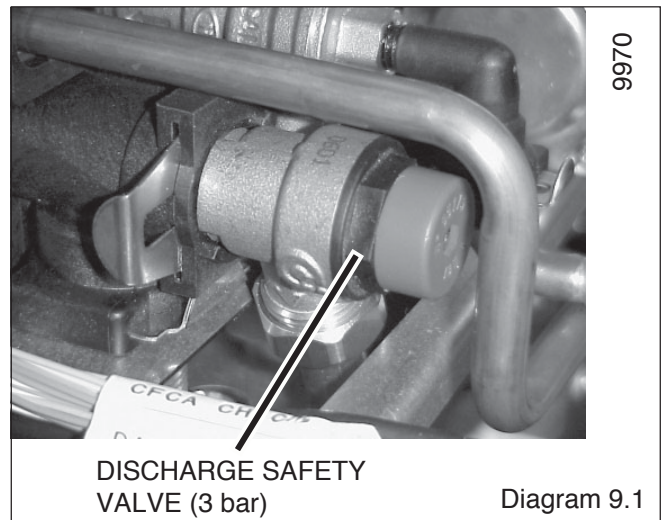

# 10 Flue Installation Telescopic and Standard

The *Telescopic flue*, (adjustable without cutting) is suitable for installations that require a flue length from 425 minimum to 659.5 maximum. There are no extensions or bends available for this flue.

The *Standard flue, suitable for side only*, (adjustable by cutting) is suitable for installations that require a flue length from 300 minimum to 930 maximum (without extensions).

**Note:** Additional 1 metre extensions, 90° and 45° bends are available. The maximum extended flue is 3m. The use of flue bends requires the flue lengths to be reduced by 1m. for 90° and 0.5m. for 45°.

The boiler is only suitable for top outlet flue connection.

## 10.1 Top outlet flue

Telescopic kit A2004500, Standard kit 86285

## 10.2 Flue systems rear

### Telescopic Flue

Extend to suit flue length required.

## 10.3 Flue systems side

### Telescopic Flue

Extend to suit flue length required.

Standard Flue, Refer to diagram 10.1.

## 10.4 Flue cutting.

### Telescopic Flue

The telescopic flue cannot be cut.

Standard Flue, refer to diagram 10.2.

**Important:** Do not leave any burrs or sharp edges on the cut ends of the pipes.

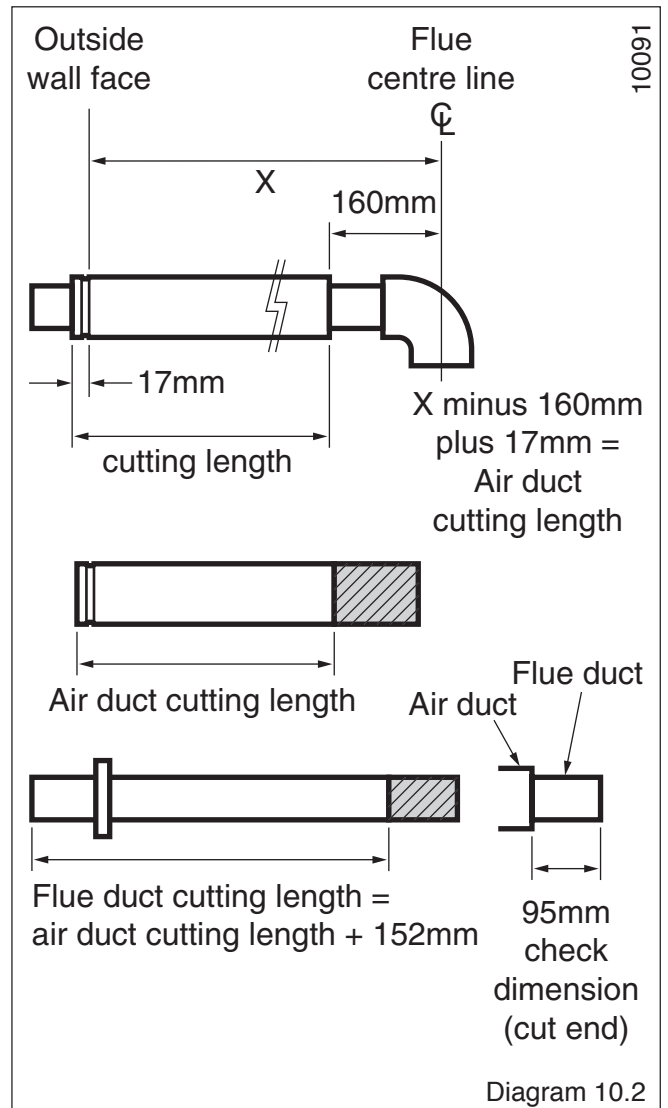
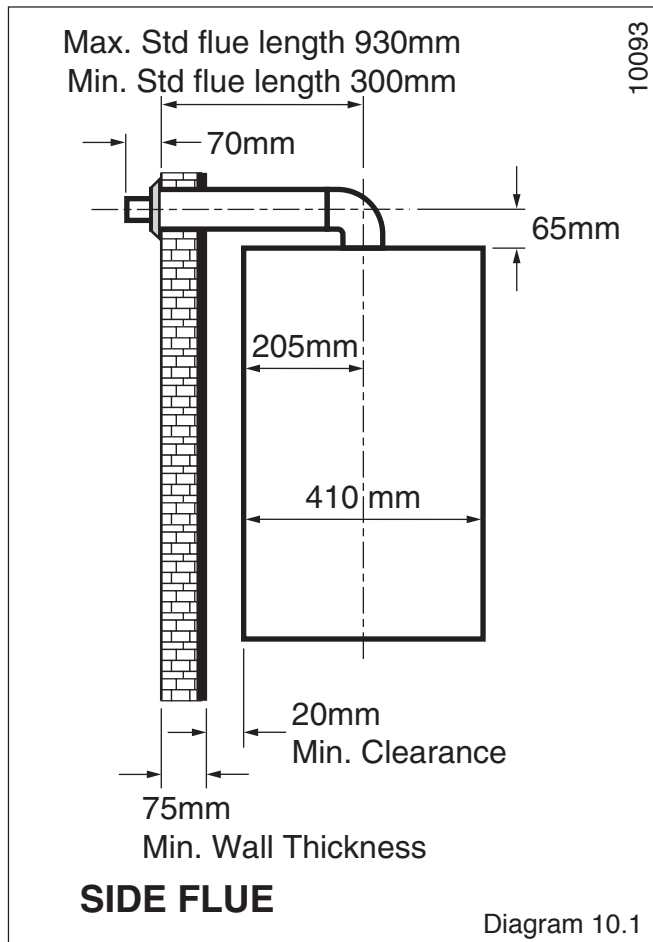

## 10 Flue Installation Telescopic and Standard

### 10.5 Installation of telescopic flue assembly

- The elbow must be removed from the air and flue duct pipes.
- Extend the telescopic flue assembly approximately 10 cm. If the telescopic flue is pulled apart care must be taken not to damage the 'O' ring on the flue duct when re-assembling.
- Remove the 2 securing screws on either side of the air elbow end of the air duct pipe, carefully pull the air duct pipe off the air elbow taking care not to disconnect the telescopic flue duct pipes.
- Remove the 2 securing screws on either side of the flue elbow to release the flue duct pipe, pull the flue duct pipe out of the flue elbow, note the 'O' ring inside the flue elbow.
- Fit rubber sealing collar (B), see diagram 10.3, into groove at the outer end of the air duct pipe (A).
- Fit air/flue duct pipe assembly (A) into wall from the outside with rubber sealing collar to the outside.
- Pull pipe assembly inwards to bring rubber sealing collar hard up against external wall, see diagram 10.5.
- Fit 'O' ring (E) into the underside of the flue elbow. Apply a small amount of silicone grease to the 'O' ring when fitting.
- Remove the backing from the self adhesive gasket (C) and carefully fit gasket to base of flue elbow.
- Leave the restrictor (a) fitted inside the fan outlet, see diagram 10.6.
- Ensure transit plate has been removed from the fan outlet, on top of the boiler.
- Fit elbow onto boiler and secure with the four screws (D).
- Re-fit the telescopic flue duct pipe to the flue elbow taking care not to tear the 'O' ring, fit the 2 securing screws.
- Re-fit the telescopic air duct pipe to the air elbow, fit the 2 securing screws.

### 10.6 Installation of standard flue assembly

- Ensure transit plate has been removed from the fan outlet, on top of the boiler.
  - Fit rubber sealing collar (F), see diagram 10.4, into groove at the outer end of pipe (A).
  - Fit air duct pipe (A) into wall with groove to the outside.
  - Pull pipe inwards to bring rubber sealing collar hard up against external wall, see diagram 10.5.
  - Fit internal plastic flange (G) onto air duct pipe. Push along the pipe until engaged against internal wall.
  - From inside, insert flue duct pipe (B) into air duct pipe.
  - Fit both 'O' rings (J) into the flue elbow (C), one at the inlet, one at the outlet. By necessity, they are a loose fit, apply a small amount of silicone grease to each 'O' ring when fitting.
  - Fixing collar (D) over air duct pipe (A) and elbow (C) ensuring it is the correct way round (Note: the fixing collar can only be fitted one way due to the different diameters of the flue elbow and air duct).
  - Take hold of the flue duct pipe and push gently onto the elbow outlet taking care not to tear the 'O' ring.
  - Open fixing collar (D) and locate between elbow and air duct pipe (A). Close fixing jig.
  - Engage the two fixing clips (E) onto the collar (D) and press down to lock into position. Secure clips with screws provided.
- Important:** If the flue has been cut, ensure that there are no burrs that could damage the 'O' ring.

- For flue systems less than 1,5 m long, fit the restrictor (a) in the fan outlet, see diagram 10.7.
- Remove the backing from the self adhesive gasket (H) and carefully fit gasket to base of flue elbow.
- Fit elbow onto boiler and secure with the four screws (I).

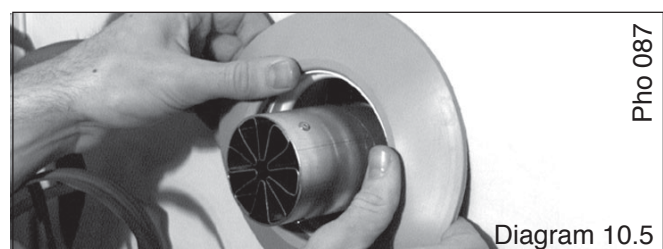
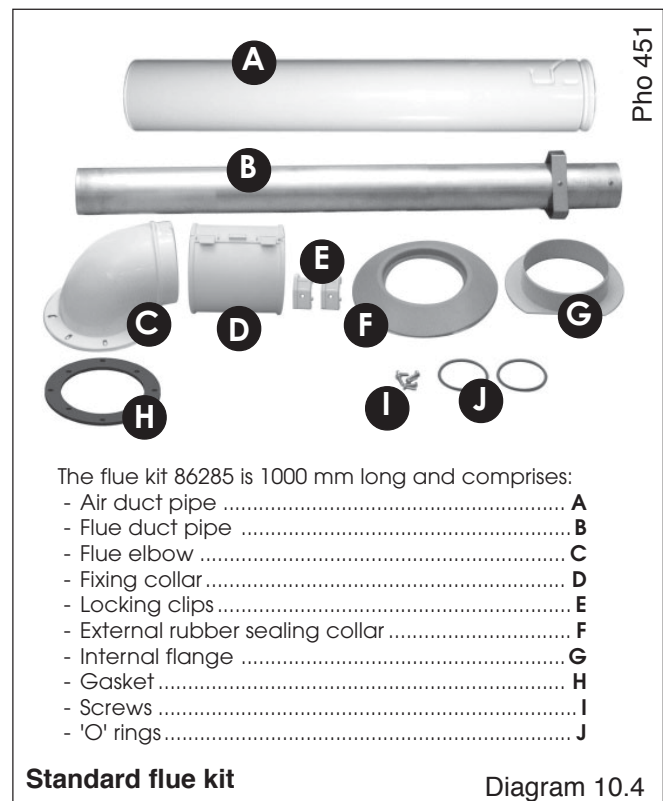
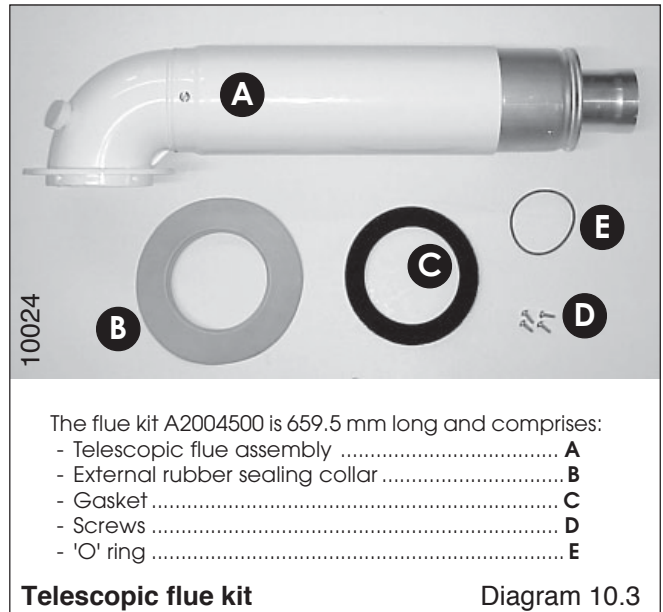

## 10 Flue Installation

### Telescopic flue system (rear and side)

The maximum permissible length (L) for the telescopic flue system is 659.5mm. The restrictor (a) must be fitted inside the fan outlet.

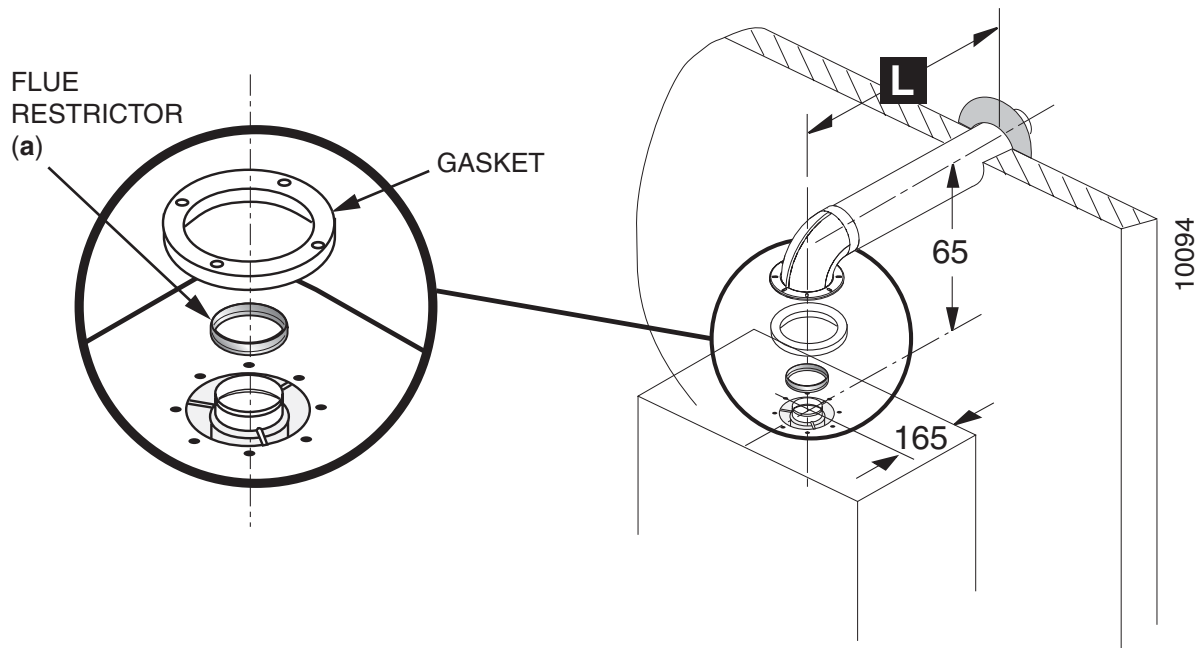

Diagram 10.6

### Standard flue system (side only)

The maximum permissible length (L) for the standard flue system is 3.0m. For flue systems up to 1.5m, the flue restrictor (a) must be fitted inside the fan outlet. For longer flue systems the restrictor must be removed. For each 90° flue elbow used, or (two 45° elbows) the maximum permissible length (L) must be reduced by 1 metre.

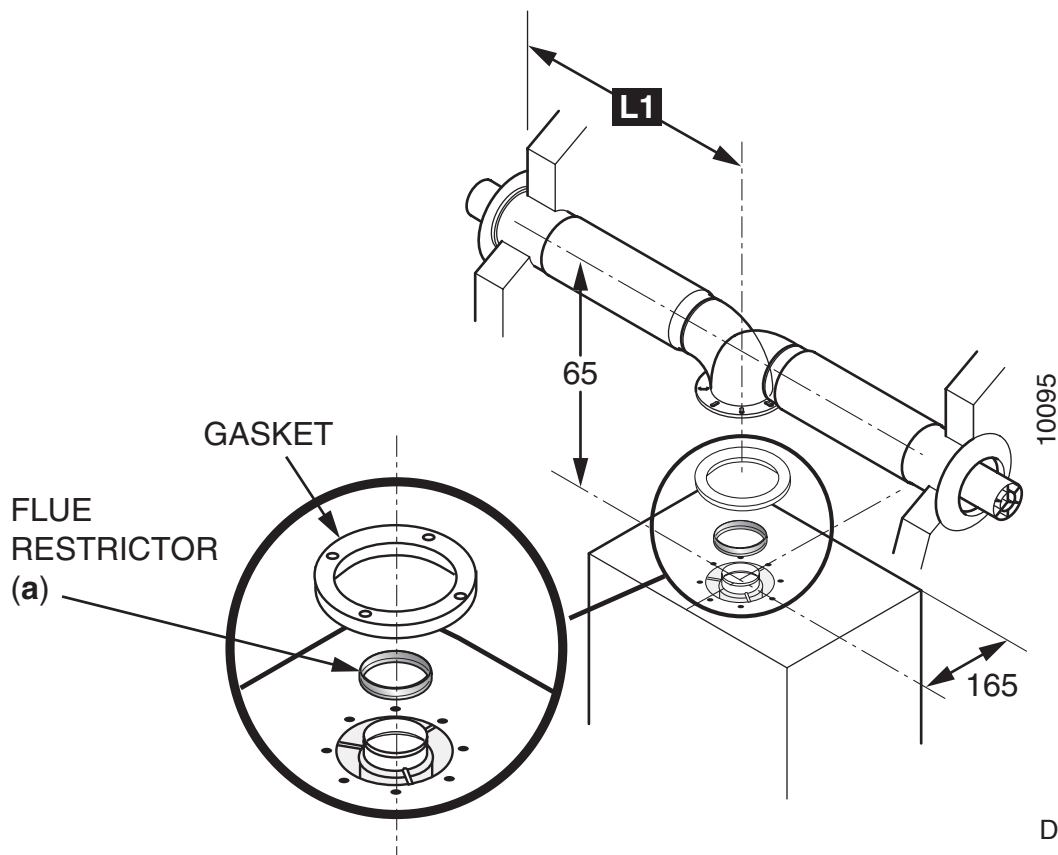

Diagram 10.7

# 11 Electrical Connection

## Warning. This boiler must be earthed

All system components must be of an approved type.

Electrical components have been tested to meet the equivalent requirements of the BEAB.

Connection of the whole electrical system and any heating system controls to the electrical supply must be through a common isolator.

Isolation should preferably be by a double pole switched fused spur box having a minimum contact separation of 3 mm on each pole. The fused spur box should be readily accessible and preferably adjacent to the boiler. It should be identified as to its use.

A fused three pin plug and shuttered socket outlet may be used instead of a fused spur box provided that:

- a) They are not used in a room containing a fixed bath or shower.
- b) Both the plug and socket comply with the current issue of BS1363.

The mains electrical supply must be maintained at all times in order to provide domestic hot water.

Do not interrupt the mains supply with a time switch or programmer.

**WARNING: UNDER NO CIRCUMSTANCES MUST ANY MAINS VOLTAGE BE APPLIED TO ANY OF THE TERMINALS ON THE VOLTAGE FREE HEATING CONTROLS CONNECTION PLUG.**

**Warning:** This appliance must be wired in accordance with these instructions. Any fault arising from incorrect wiring cannot be put right under the terms of the **Glow-worm** guarantee.

Important: If a replacement supply cable is required it must be purchased. Part No. S1008600.

## 11.1 External controls - Voltage Free

This boiler will operate on heating as supplied, provided that the wire link (E) fitted between the two terminals of the heating controls connection plug is left in place, see **diagram 11.1**.

External controls e.g. room thermostat, frost thermostat etc. should be fitted in accordance with the rules in force.

**WARNING: UNDER NO CIRCUMSTANCES MUST ANY MAINS VOLTAGE BE APPLIED TO ANY OF THE TERMINALS ON THE VOLTAGE FREE HEATING CONTROLS CONNECTION PLUG.** If mains voltage controls are required, see **section 11.2**.

Refer to the wiring diagram **Section 17**.

## 11.2 External controls - Mains Voltage

Remove the MAINS VOLTAGE HEATING CONTROLS CONNECTION PLUG from the fittings pack and install on the 230V interface control board as shown on the instruction sheet, also provided in the fittings pack and **diagram 11.2**

Gain access to the 230V interface by unclipping the control panel and hinge forward.

The wire link (E) must be removed from the voltage free heating controls connection plug.

External controls e.g. room thermostat, frost thermostat etc. should be fitted in accordance with the rules in force.

Refer to the wiring diagram **Section 17**.

## 11.3 Testing - Electrical

Checks to ensure electrical safety must be carried out by a competent person.

After installation of the system, preliminary electrical system checks as below should be carried out.

1. Test insulation resistance to earth.
2. Test earth continuity and short circuit of all cables.
3. Test the polarity of the mains.

The installer is requested to advise and give guidance to the user of the controls scheme used with the boiler.

**Note:** For further information, see the building regulations 1991 - Conservation of Fuel and Power - 1995 edition - appendix G, Table 4b.

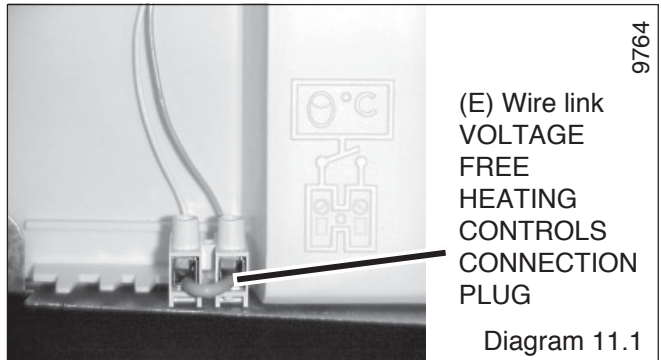
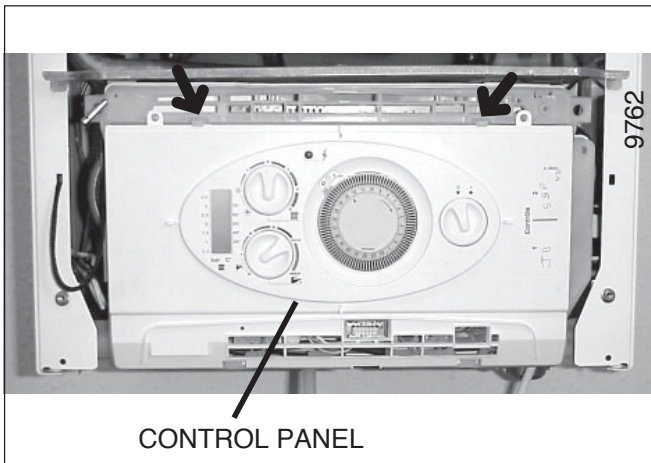

Diagram 11.1



CONTROL PANEL

MAINS VOLTAGE EXTERNAL CONTROLS CONNECTION PLUG

230V CONTROLS BOARD

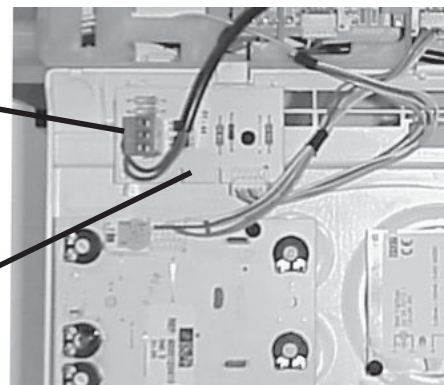

Diagram 11.2

## 12 Commissioning

Please ensure the "Benchmark" logbook is completed and left with the user.

The commissioning and first firing of the boiler must only be done by a qualified registered person.

### Gas installation

It is recommended that any air is purged from the supply at the gas inlet test point on the gas valve, see **diagram 12.1**.

### Filling the system 1 to 8

1.

#### Make sure that:

- The boiler is connected to the electrical supply.
- The gas service cock is open.

Turn the switch **OFF ( 0 )**

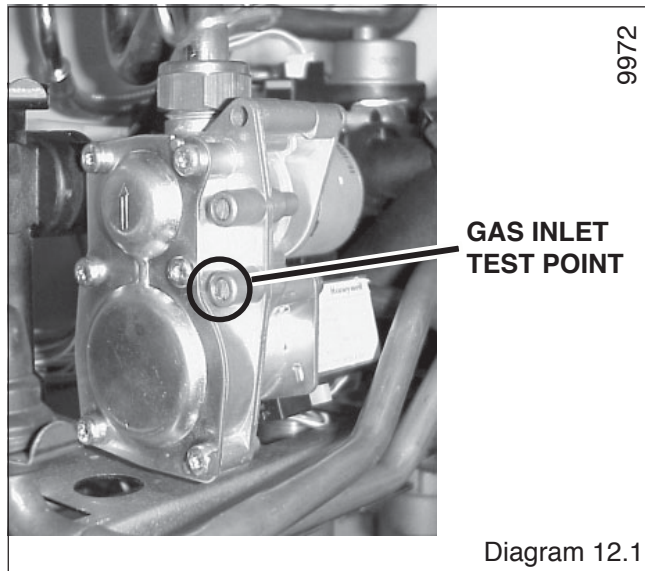

2.

- Open the three boiler isolating valves. The slot of the screw corresponds to flow direction. (To unscrew turn anti-clockwise).

Fully open valves by turning anti-clockwise.

9838

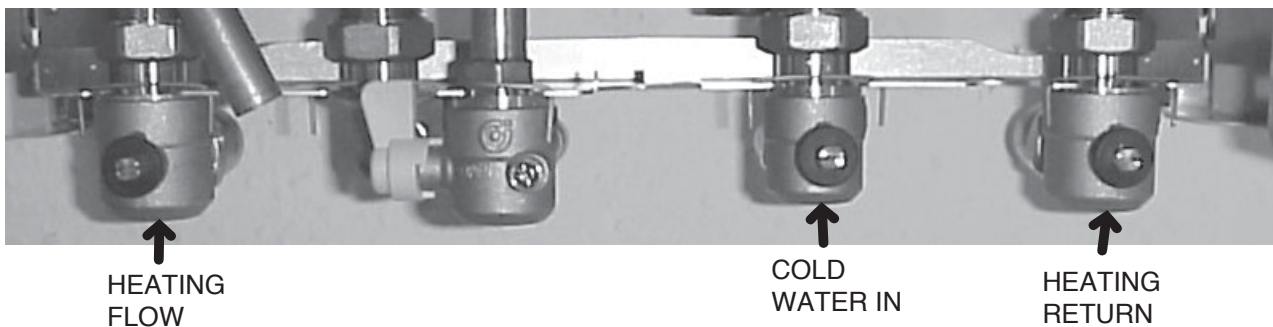

3.

- Undo cap on automatic air vent on top of pump and leave undone.

9973

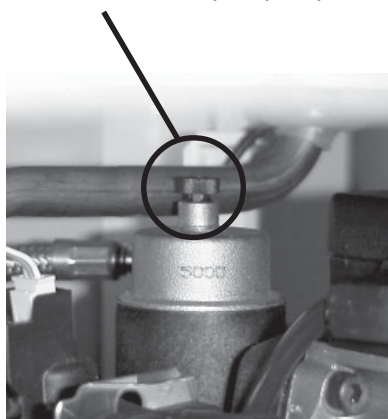

4.

- Turn the switch **ON ( I )**
- Open the tap on the filling device and fill the system until the pressure indicated on the display is 2 bar. Close filling device.

9974

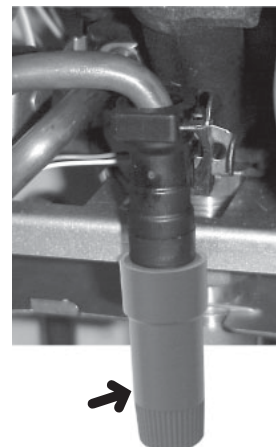

## 12 Commissioning

5.

- Bleed each radiator to remove air, ensure all bleed screws are re-tightened.
- If necessary repressurise the system, refer to procedure 4



Ins 061a

6.

- Leave cap on automatic air vent on top of pump open.

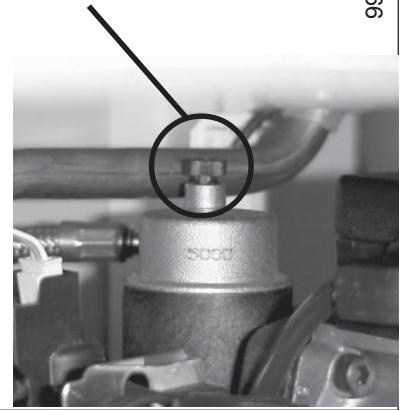

9973

7.

- Open various hot water taps to bleed system



Ins 062a

8.

- Ensure the display indicates a system pressure of 1.5 bar adjust if necessary.

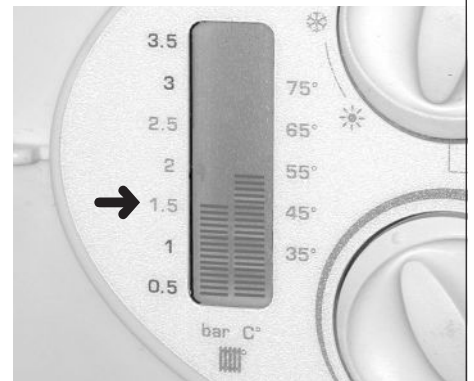

9696

- Adjust heating temperature to maximum .
- Check that any external controls, if fitted, are calling for heat (set room thermostat to maximum).
- Allow the temperature to rise to the maximum value, with all radiator valves open. The temperature rise will cause release of the gases contained in the water of the central heating system.
- Gases driven towards the boiler will be automatically released through the automatic air vent.
- The gases trapped at the highest point of the system must be released by bleeding the radiators. Check the burner gas rate required, ten minutes from lighting. Refer to Data Label on electrical controls box. Should there be any doubt about the gas rate it should be checked at the meter.

On reaching maximum temperature, the boiler should be turned off and the system drained as rapidly as possible whilst still hot.

- Refill system to a pressure of between 1 and 2 bar and vent as before.
- Restart boiler and operate until a maximum temperature is reached. Shut down boiler and vent heating system. If necessary, top up heating system and make sure that a pressure of at least 1 bar is indicated when system is COLD.

Flush the domestic hot water system by opening the hot water taps for several minutes.

Remove the magnetic lighting instructions label from the document envelope and position it on the surface of the boiler casing.

### Instruct the User

Instruct and demonstrate the lighting procedure and advise the user on the safe and efficient operation of the boiler.

Instruct on and demonstrate the operation of any heating system controls.

Advise the user on the use and maintenance of any scale reducer and pass on any relevant instructional documents.

Advise that to ensure the continued efficient and safe operation of the boiler it is recommended that it is checked and serviced at regular intervals. The frequency of servicing will depend upon the installation conditions and usage, but in general, once a year should be enough.

Draw attention, if applicable, to the current issue of the Gas Safety (Installation and Use) Regulations, Section 35, which imposes a duty of care on all persons who let out any property containing a gas appliance.

It is the Law that any servicing is carried out by a competent person.

Advise the user of the precautions necessary to prevent damage to the system, boiler and the building, in the event of the heating system being out of use during frost or freezing conditions.

Advise the user that the permanent mains electrical supply SHOULD NOT be switched off, as the built in frost protection and pump saver program would not be operable.

Reminder, leave these instructions and the 'Benchmark' logbook with the user.

## 14 Settings

### Bypass

The 23c boiler has a built-in bypass. This must be adjusted according to the requirements of the system, refer to the flow rate pressure curve (**diagram 1.1**). The boiler is supplied with the built-in bypass open a half a turn. It is adjusted by turning the bypass screw (**a**), **see diagram 14.1**. Turn the screw clockwise to close the bypass. When using thermostatic radiator valves (TRV's) on all of the radiators, it is essential that a separate, adjustable bypass of 15 mm minimum diameter is fitted between the flow and return of the heating circuit, **see diagram 8.1**. Any bypass must be fitted before system controls.

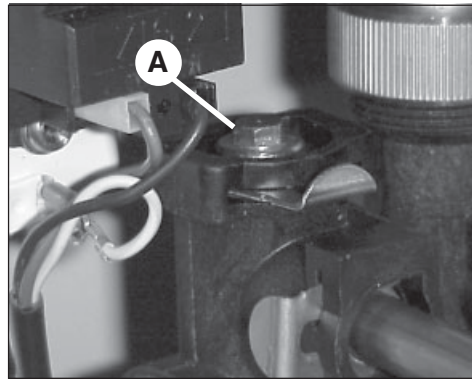

9975

Diagram 14.1

## 15 Routine Cleaning and Inspection

REMEMBER, when replacing a part on this appliance, use only spare parts that you can be assured conform to the safety and performance specification that we require. Do not use reconditioned or copy parts that have not been clearly authorised by Hepworth Heating.

To ensure the continued efficient and safe operation of the boiler it is recommended that it is checked and serviced at regular intervals. The frequency of servicing will depend upon the particular installation conditions and usage, but in general once a year should be enough.

It is the law that any servicing is carried out by a qualified registered person.

### 15.1 Products of combustion check

Note: To obtain a products of combustion reading, unscrew the left hand sampling point cap on the flue elbow, located on top of boiler, see diagram 15.1.

Connect the analyser tube onto sampling point.

Refer to the combustion product values in **Section 1 Technical Data**.

Switch on the electrical supply and gas supply, then operate the boiler.

On completion of the test switch off the electrical supply and the gas supply, remove analyser tube and replace sampling point cap.

### 15.2 Service Check and Preparation.

- Isolate boiler from the gas and electrical supplies.
- Drain the Domestic hot water circuit and the boiler, refer to diagram 15.2.
- On completion check all gas-carrying parts for soundness with leak detection fluid.
- Remove boiler casing as follows:

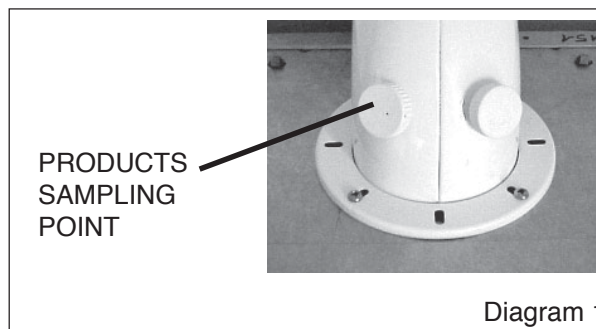

9532

Diagram 15.1

### 15.3 Front panel

- Unscrew and remove the two retaining screws from the bottom of the front panel.
- Remove front panel by pulling forward and lifting up.

### 15.4 Control panel

- Lower forwards to gain access to lower part of boiler.

### 15.5 Sealed chamber cover

- Unclip the two toggle clips holding the sealed chamber cover, **see diagram. 15.3**.
- Lift cover up and off pins on the top of the boiler.

## 15 Routine Cleaning and Inspection

### To Drain the Domestic hot water circuit

- Close boiler isolating valve (c). • Turn on one or more hot water taps.

### To Drain the boiler

- Close isolating screws on the isolating valves (b), (c) and (d) turn from vertical to horizontal to close.
- Open the boiler drain valve (a). • Turn on one or more hot water taps.

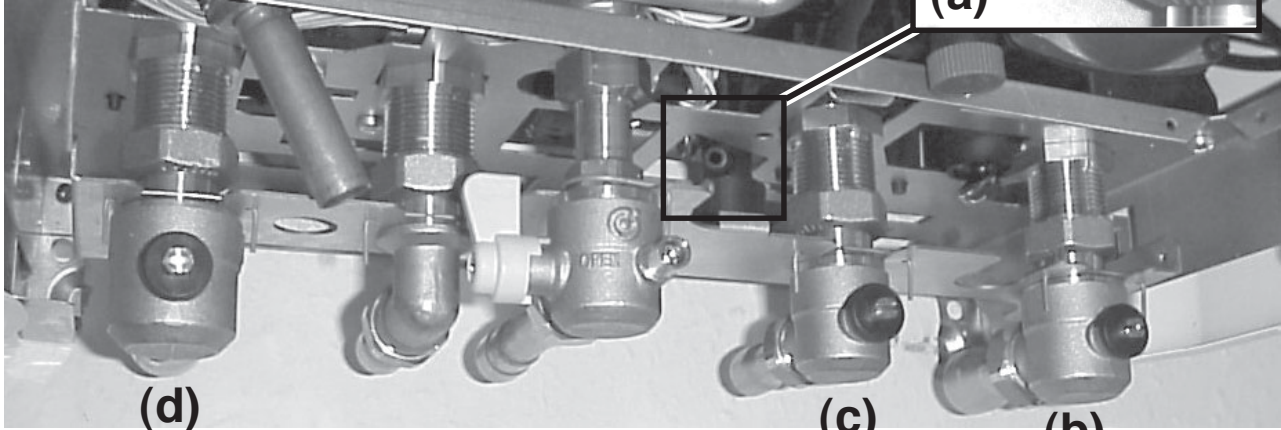
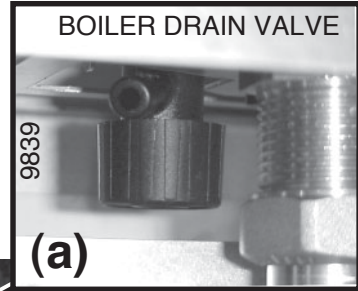

**(d)**  
HEATING  
FLOW

Note: Isolating cocks water and gas  
are shown in the: OFF position

**(c)**  
COLD  
WATER IN

**(b)**  
HEATING  
RETURN

Diagram 15.2



Diagram 15.3

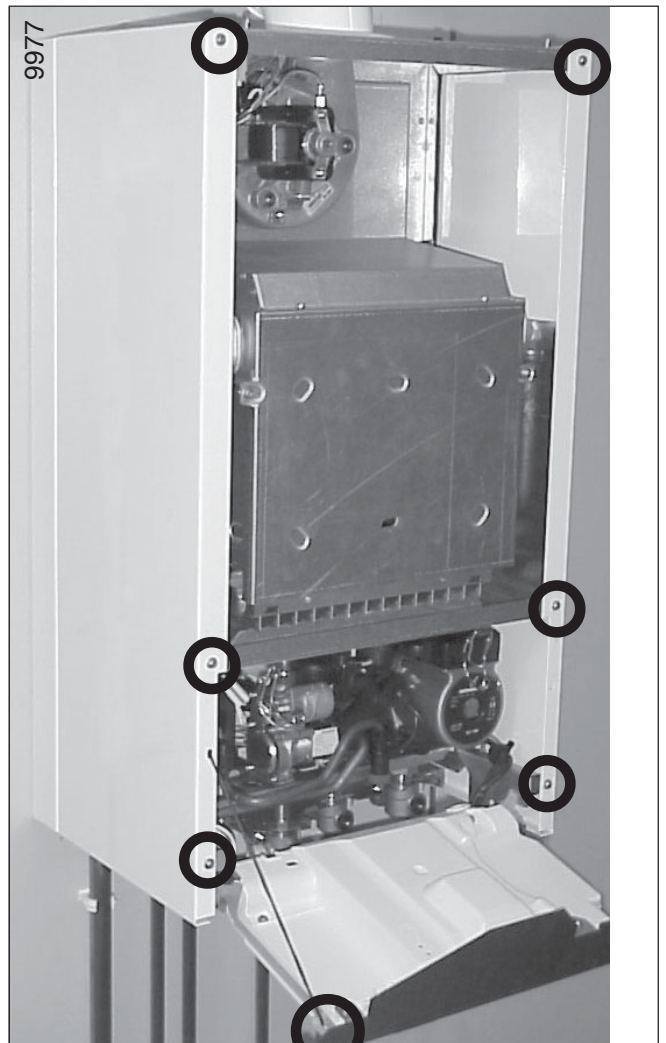

Diagram 15.4

## 15 Routine Cleaning and Inspection

### 15.6 Side panels (for ease of access if required), refer to diagram 15.4.

- Support the side panels as you remove them.
- Unscrew and remove the three retaining screws from front of each side panel.
- Left hand side panel only disconnect the control panel retaining strap at the control panel.
- Pull each panel forward from the rear retaining pins to remove.

### 15.7 Combustion chamber cover

- Unscrew and remove the four screws securing combustion chamber cover to combustion chamber, **see diagram 15.5**.
- Remove combustion chamber cover from boiler.
- Take care not to damage the insulation.

### 15.8 Spark and Sense Gaps

- Check that the spark and sense gaps as shown in **diagram 15.6**. Note: To gain access to spark and sense electrodes for removal, refer to **Section, 18.12 and 18.13 in Replacement of Parts**.

### 15.9 Burner, refer to diagram 15.7.

- Unscrew and remove the two burner retaining screws.
- Remove burner from boiler by easing it forward off the two burner guides.
- Clean burner by washing in soapy water. Dry thoroughly before refitting.

Note: To gain access to injectors for removal and cleaning, refer to **Section, 18.8 in Replacement of Parts**.

### 15.10 Fan, refer to diagram 15.8.

- Disconnect power supply leads and earth lead from fan.
- Remove air pressure switch sensing tube from the side of the fan.
- Unscrew and remove the fan retaining screw.
- Ease the fan down and forwards to remove.

### 15.11 Heat exchanger, refer to diagram 15.9.

- Remove the two flue hood retaining screws to remove the flue hood.
- Use a soft brush or vacuum clean the heat exchanger.

**DO NOT USE ANY TOOL LIKELY TO DAMAGE PAINTED FINISH OF HEAT EXCHANGER.**

### 15.12 Domestic water inlet filter, refer to diagram 15.10.

If the water flow rate through the appliance has reduced it may be necessary to clean or replace the domestic water inlet filter.

- Pull out slotted clip securing the filter in its housing, remove the filter to clean or renew if necessary.

Replace the filter into its housing and replace the securing clip.

- Open isolating valve (c) on cold water inlet and test the Domestic Hot Water circuit for soundness.

### 15.13 Central Heating Filter, refer to diagram 15.11.

Remove the filter retaining clip and filter clean or renew if necessary.

Refit the filter, ensuring the correct orientation. The flat and hole in the filter as shown. Secure with retaining clip.

### 15.14 Reassembly of parts removed for servicing

All parts are replaced in reverse order to removal.

### 15.15 Flue system

- Check externally to make sure that flue is not blocked
- Inspect flue system to make sure that all fittings are secure.

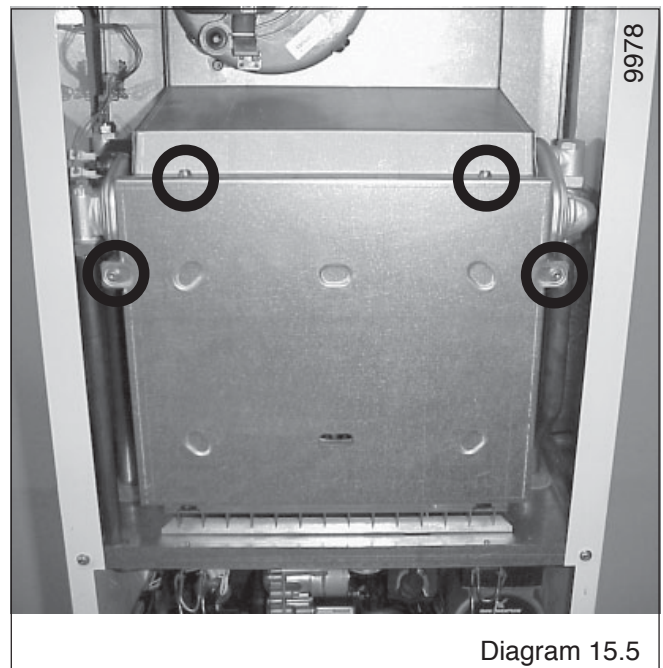

Diagram 15.5

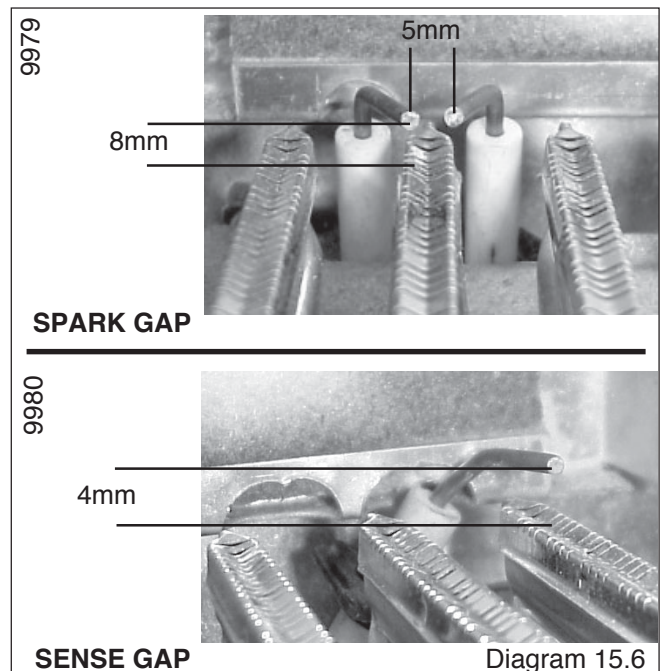
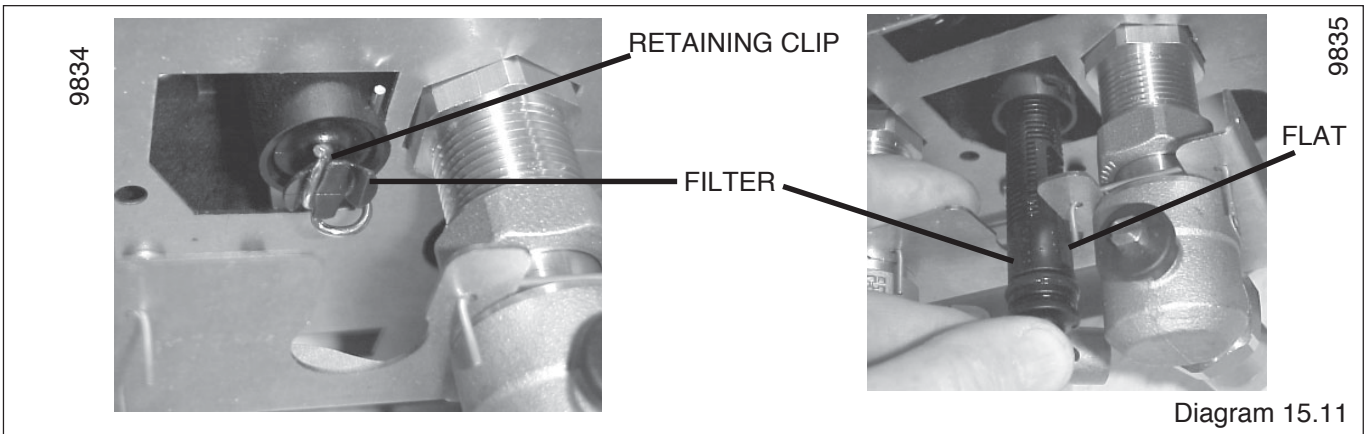
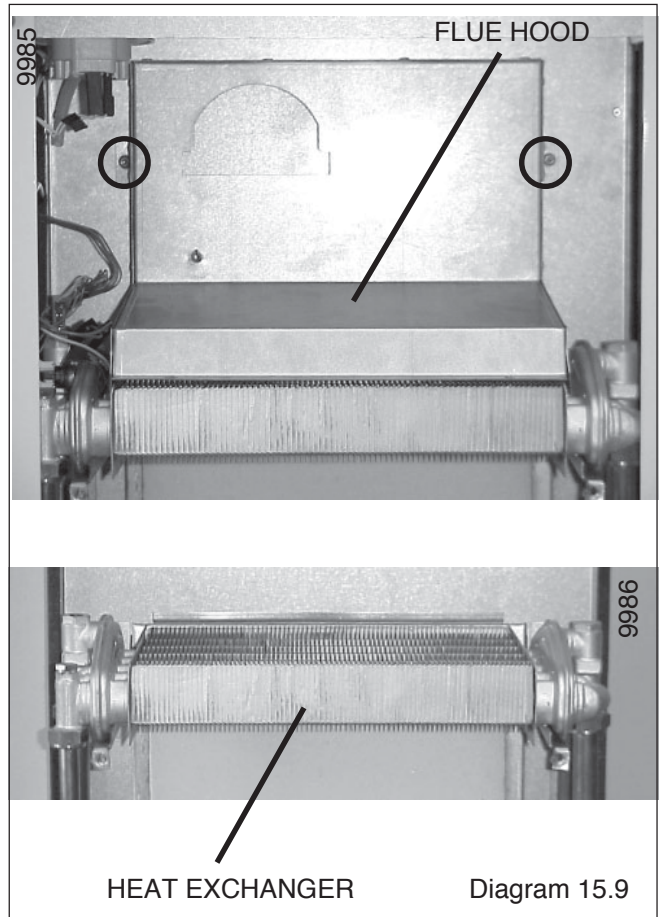
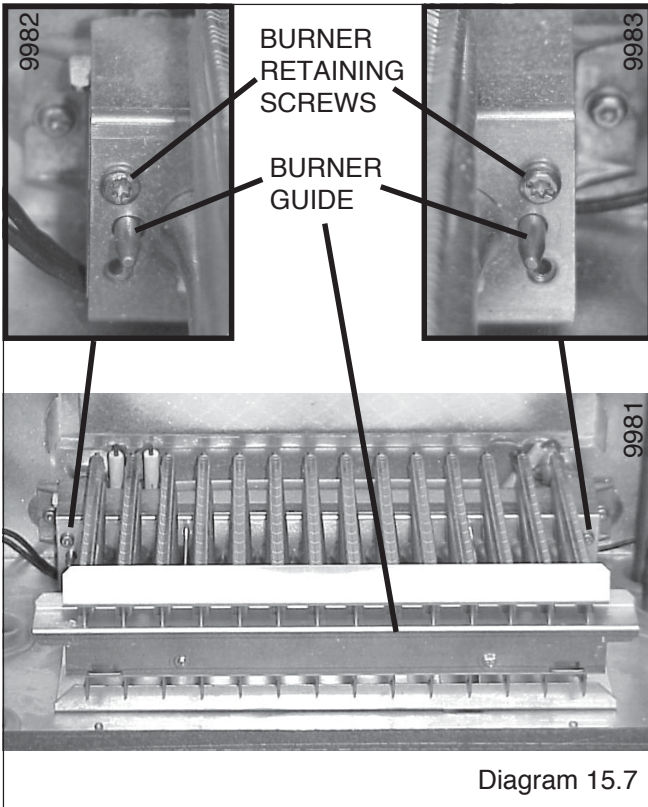

Diagram 15.6

# 15 Routine Cleaning and Inspection



## 16 Fault Finding

Before trying to operate the boiler make sure that :

- All gas supply cocks are open and that the gas supply has been purged of air.
- The heating system pressure is at least 1 bar.
- There is a permanent mains supply to the boiler.
- The fuse on the PCB is intact.

**WARNING.** Always isolate the boiler from the electrical supply before carrying out any electrical replacement work.

Always check for gas soundness after any service work.

Should there be any doubt about the voltage supply to any of the components, it is possible to carry out a simple electrical test to ensure all is operational in that area.

To carry out the electrical test, gain access to the main Printed Circuit Board (PCB), as described previously, and measure the voltages according to table 2.

**IMPORTANT:** On completion of the fault finding task which has required the breaking or remaking of the electrical connections, the continuity, polarity, short circuit and resistance to earth checks must be repeated using a suitable multimeter.

**Table 2**

Voltage	Measured value	Measuring point
<b>230 Volt</b>	<b>230V AC</b>	<b>Between terminals H8.1 and H8.2</b>
<b>24 Volt</b>	<b>maximum 33V DC minimum 20V DC</b>	<b>Between terminals J5.3 and J15.1</b>
<b>18 Volt</b>	<b>18V ± 1V</b>	<b>Between terminals J2.9 and J2.10</b>
<b>Display</b>	<b>5V ± 0.5V</b>	<b>Between terminals J13.4 and J13.1</b>

TYPE OF FAULT	CHECK
No domestic hot water or central heating (No flashing warning light on control panel)	<ul style="list-style-type: none"> <li>• 230V supply</li> <li>• Is fuse blown</li> <li>• Loose connections on control board (PCB)</li> <li>• Faulty control or interface board (PCB's)</li> </ul>
No domestic hot water or central heating (A flashing warning light on control panel)	<ul style="list-style-type: none"> <li>• Water pressure</li> <li>• Shortage of air or gas</li> <li>• Faulty temperature sensor</li> <li>• Overheating</li> <li>• Wrong flue length</li> <li>• Connections on air pressure switch (electrical or tubes) disconnected</li> </ul>
No hot water but central heating ok	<ul style="list-style-type: none"> <li>• Loose connections at hot water flow sensor.</li> <li>• Faulty hot water flow sensor.</li> <li>• Faulty control board (PCB).</li> </ul>

## 16 Fault Finding

COMPONENT	NORMAL MEASURE	CHECK
Gas control valve Resistance of coil 116Ω	<i>Under demand during ignition sparks:</i> 24V dc for 1 to 2 seconds, then 12Vdc (constant) at the gas control valve electrical connection.	<i>If 0 Volt:</i> the gas control valve is not faulty. <i>If 24 Volts and then 12 Volts but no gas at the burner:</i> Check if the gas control valve is stuck. If not, check the stepper valve.
Adjustment valve ( step motor)	<i>Close the gas inlet:</i> Dismantle the step motor (screw not sealed in). Trigger a demand and check that the valve opens during the ignition.	<i>If the valve does not move:</i> Check the connections at both motor and control board (PCB). Change the motor. Replace the control board (PCB).
Domestic water flow		<i>To test:</i> Use a new detector and connect it electrically in place of the faulty one . Blow through to simulate a demand for water.

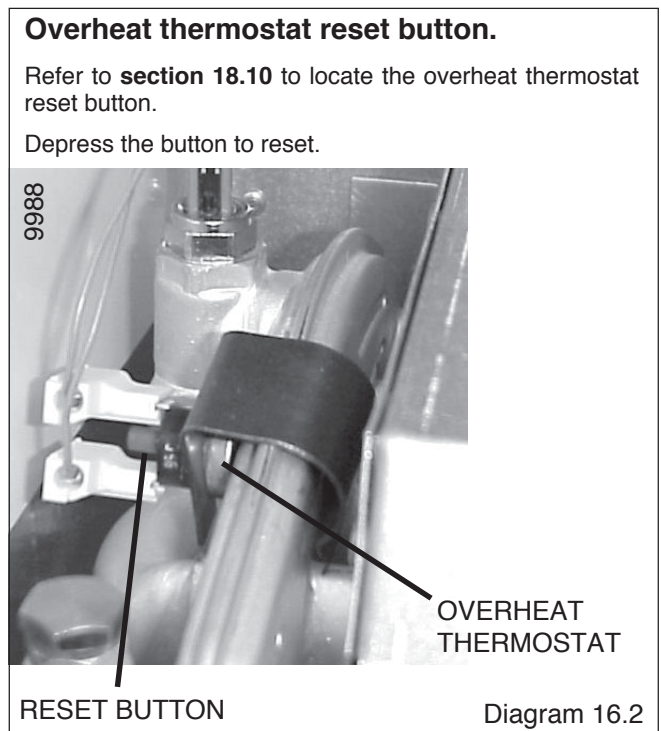
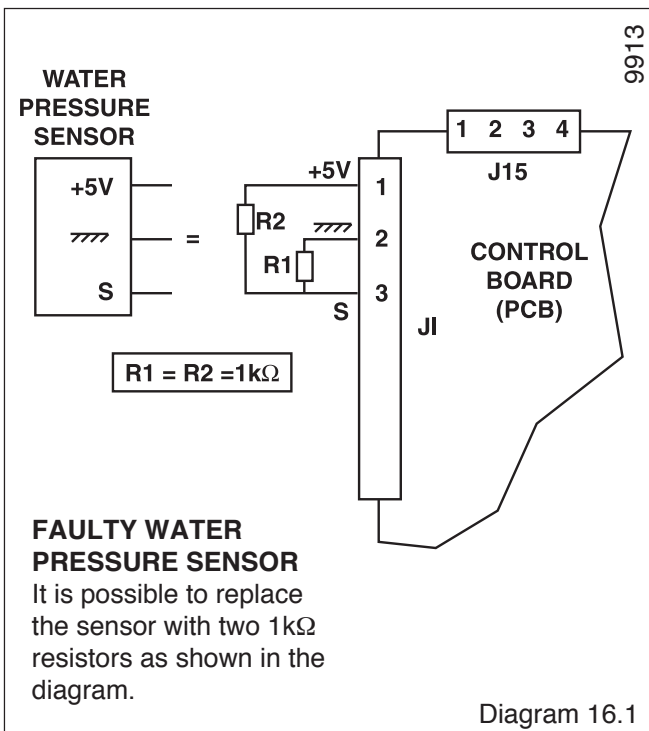

## 16 Fault Finding

### FAULT: NO HEATING, BUT HOT WATER AT TAPS

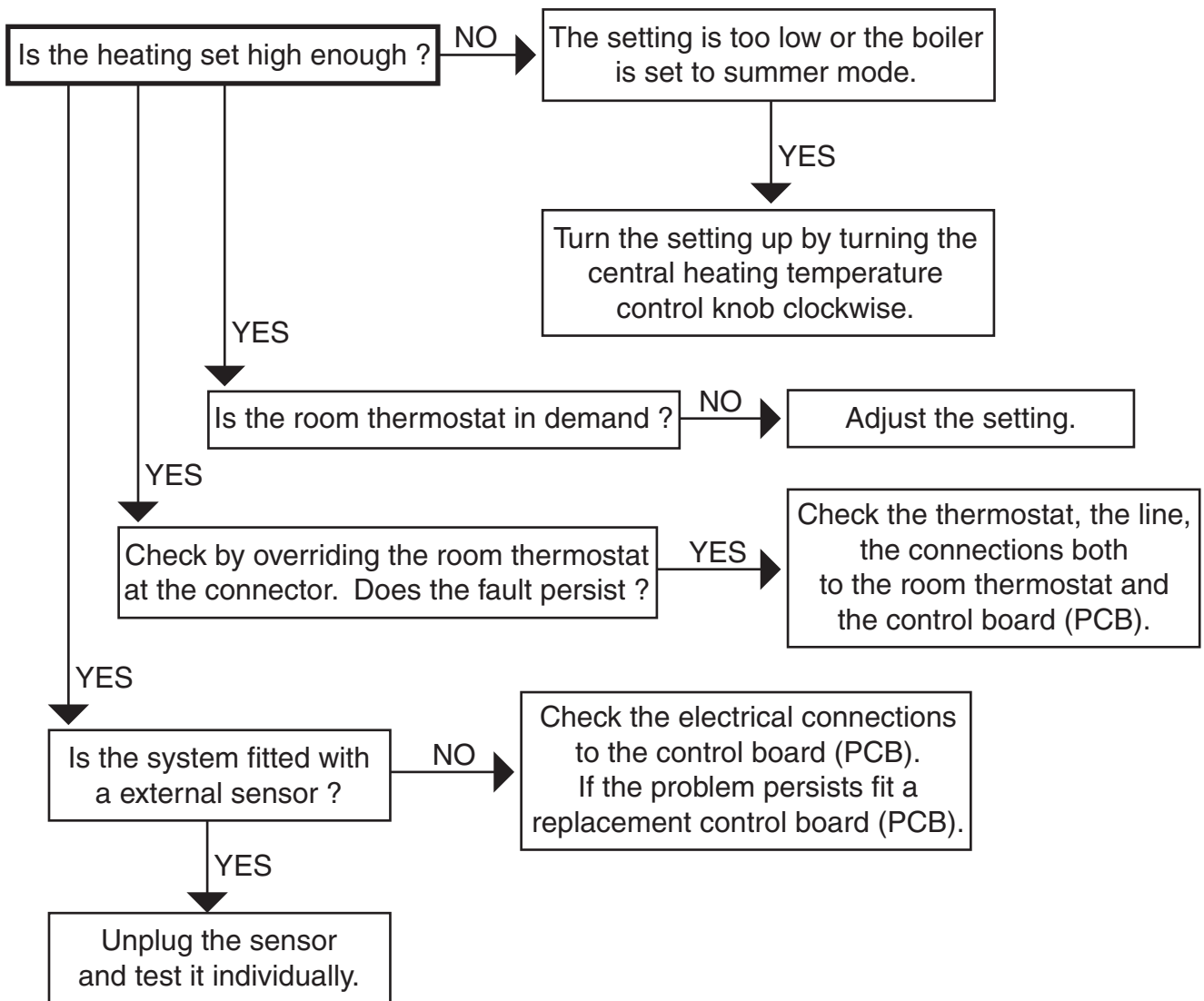

## 16 Fault Finding

### FAULT: NO HOT WATER, BUT THE HEATING IS WORKING

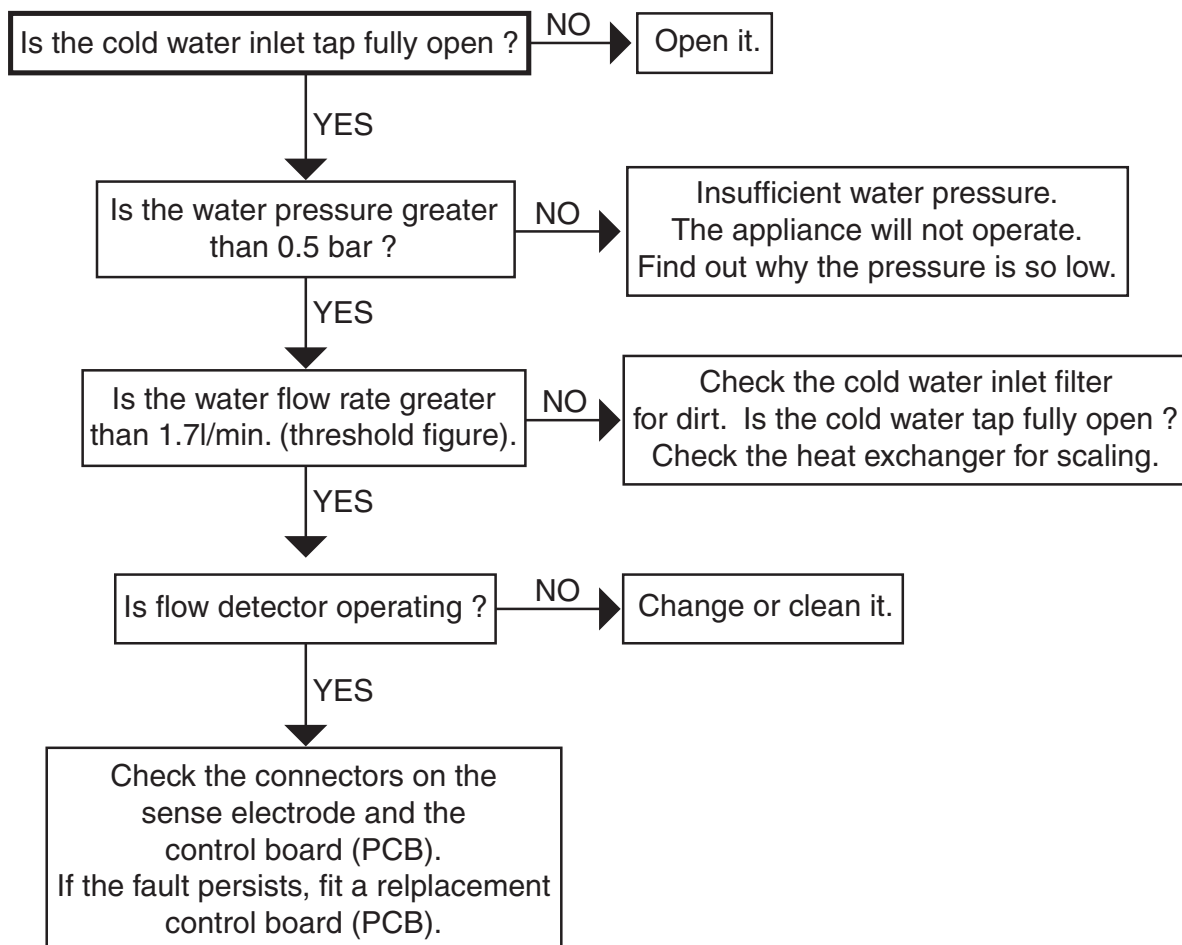

### FAULT: THE BURNER LIGHTS BUT THEN GOES OUT. THERE IS NO FLAME DETECTED.

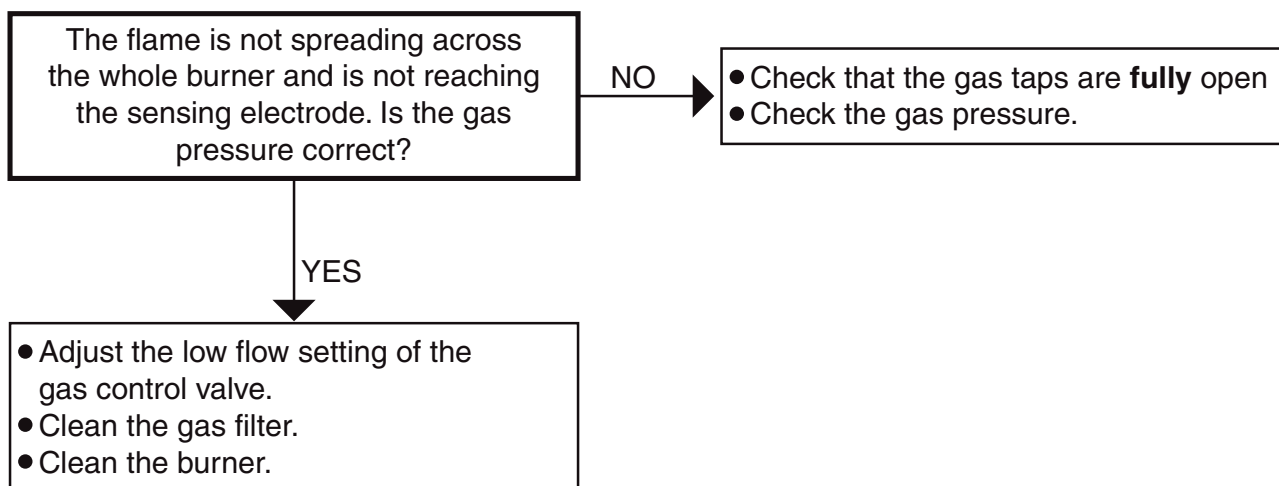

## 16 Fault Finding

### FAULT: THE BURNER LIGHTS, THEN GOES OUT.

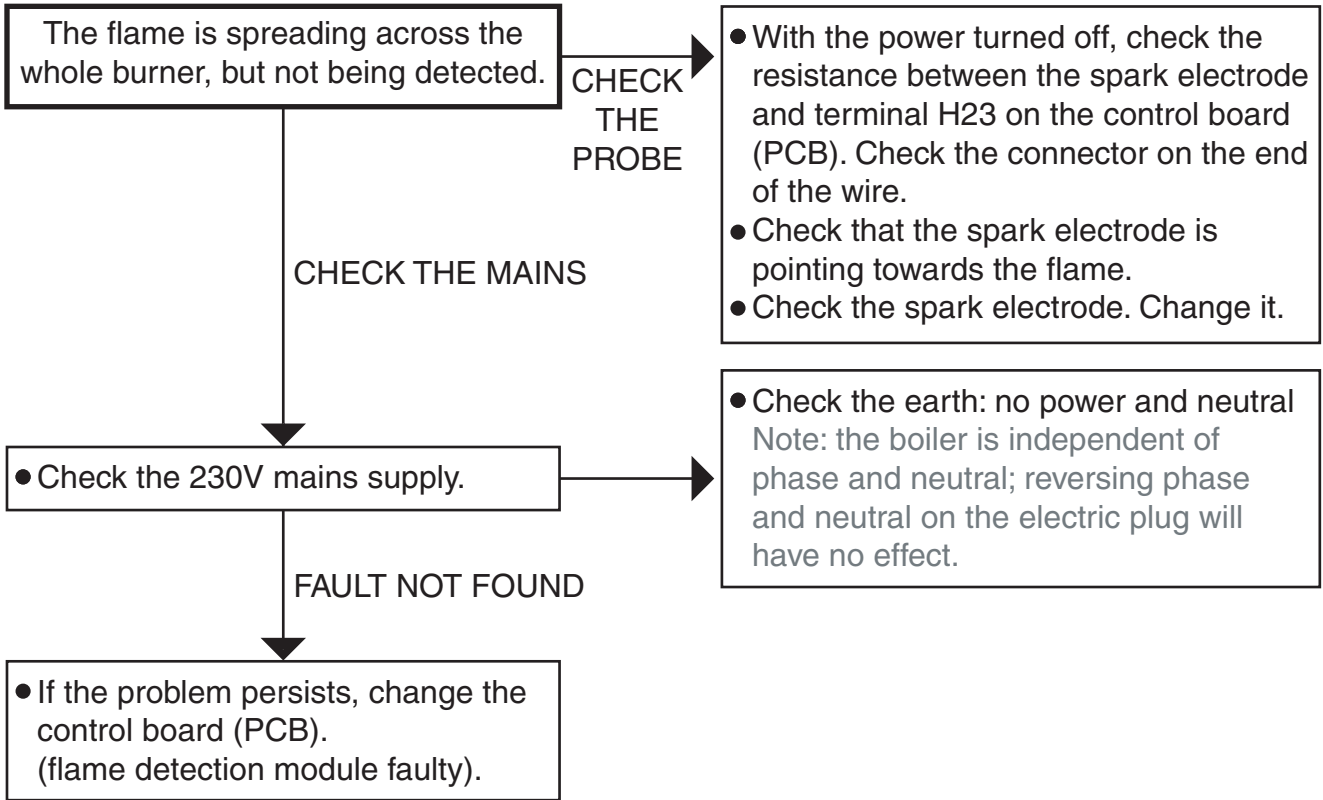

### FAULT: THE BURNER DOES NOT LIGHT AT ALL, BUT THERE IS AN IGNITION SPARK.

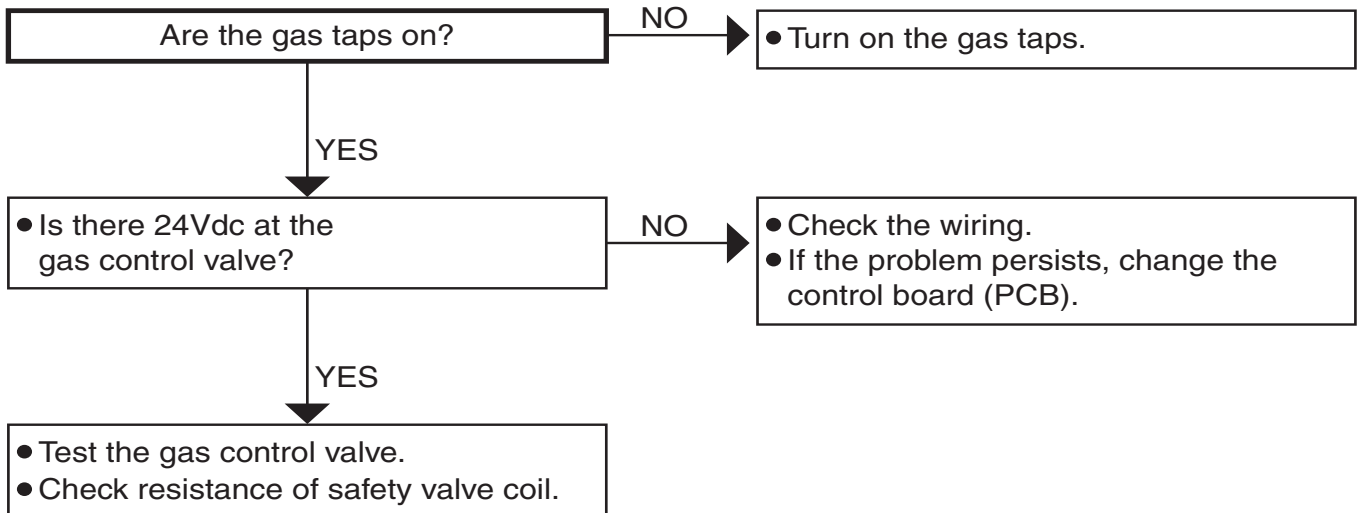

## 16 Fault Finding

### FAULT: THE RADIATORS ARE LUKE-WARM.

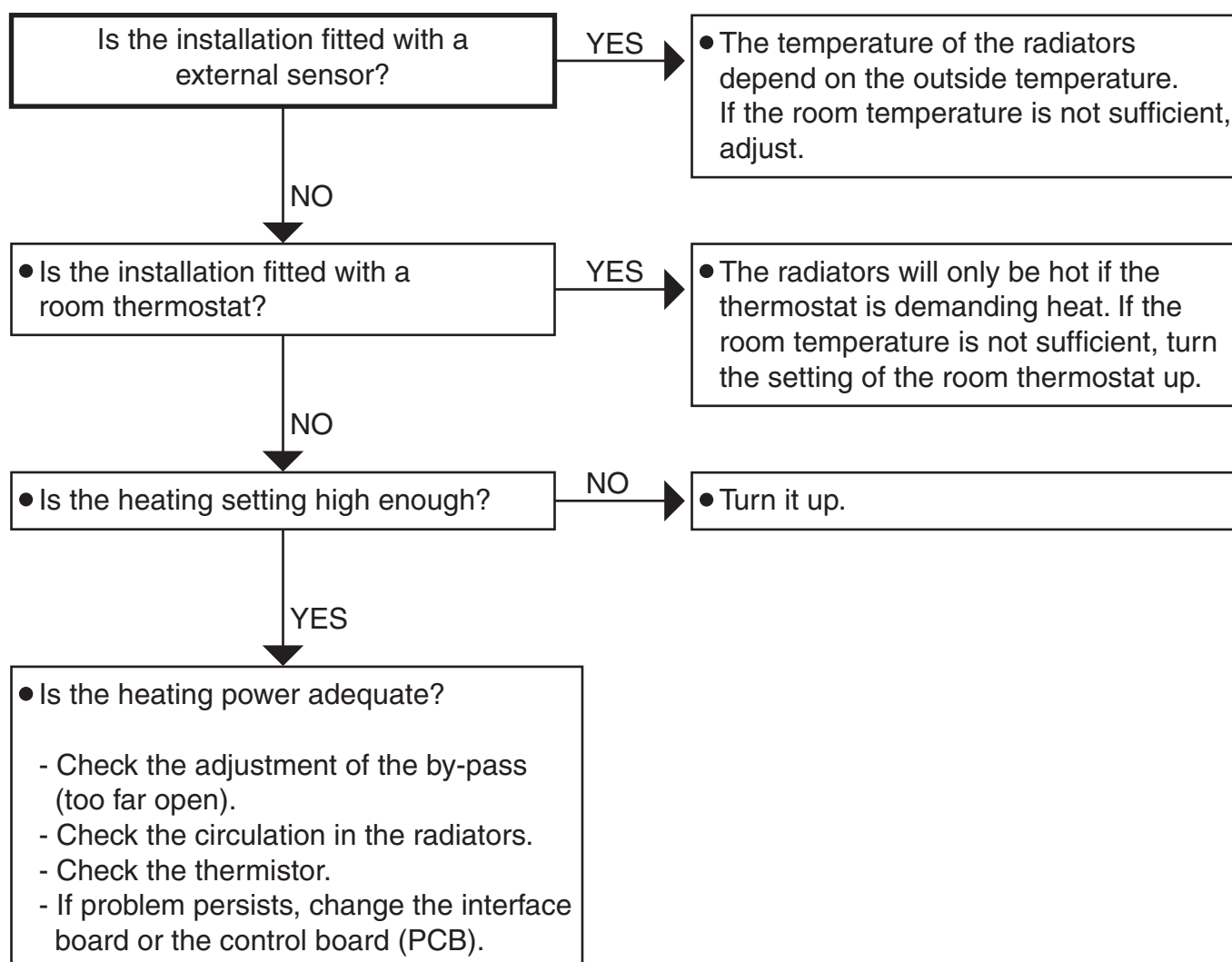

### FAULT: THE WATER AT THE TAPS IS LUKE-WARM.

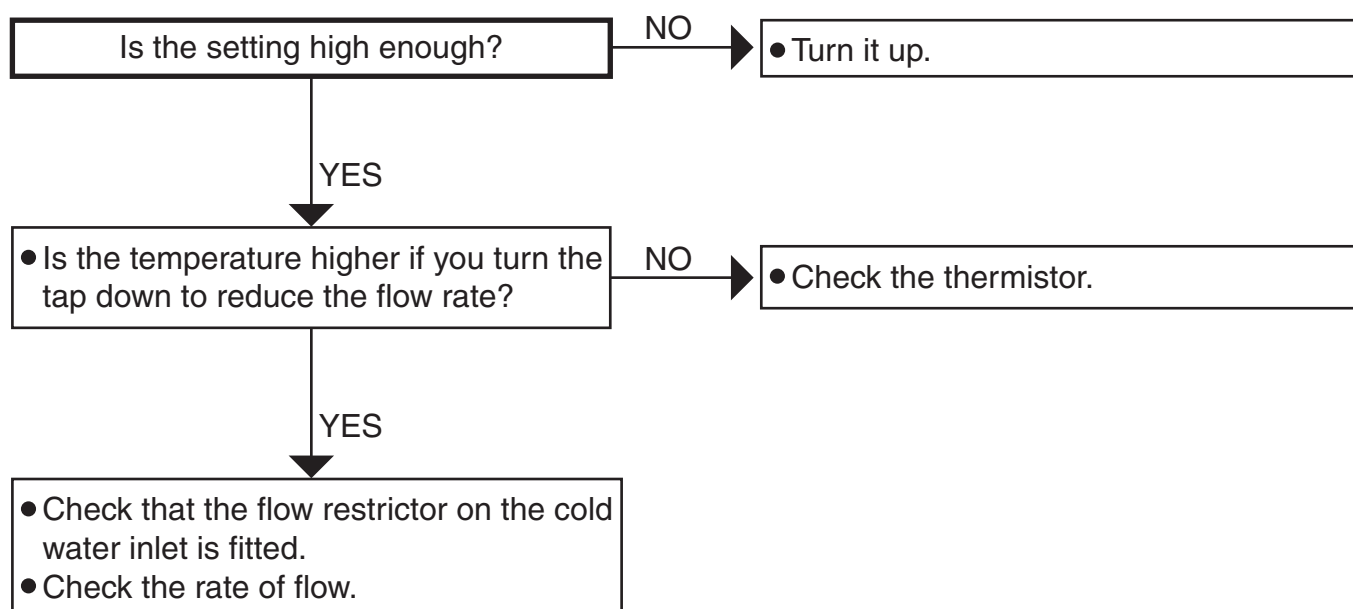

## 16 Fault Finding

### FAULT: THE FAN DOES NOT START.

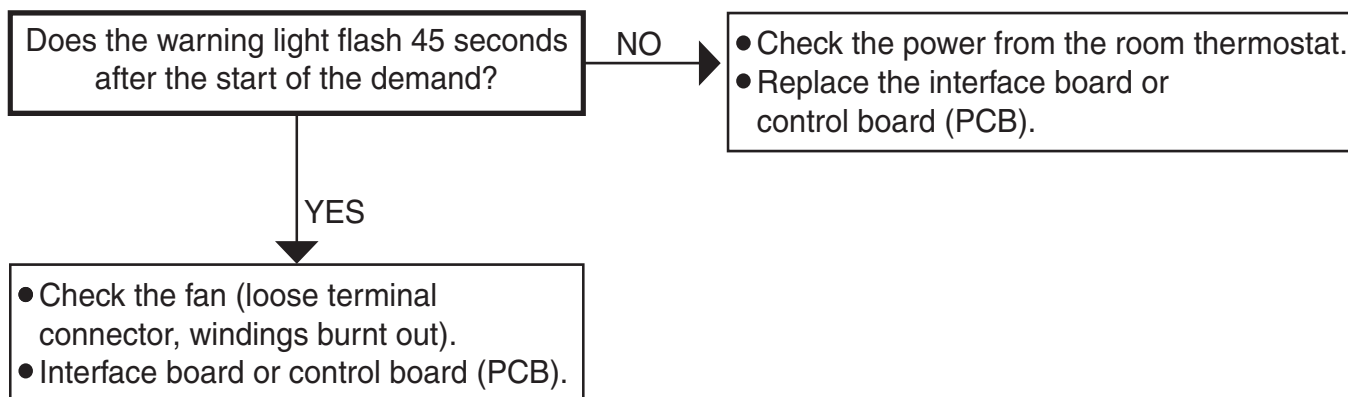

### FAULT: THE FAN RUNS BUT THERE ARE NO SPARKS.

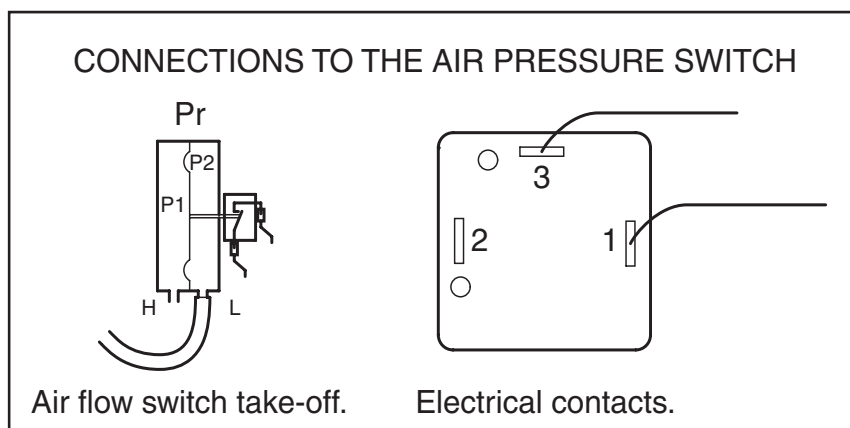
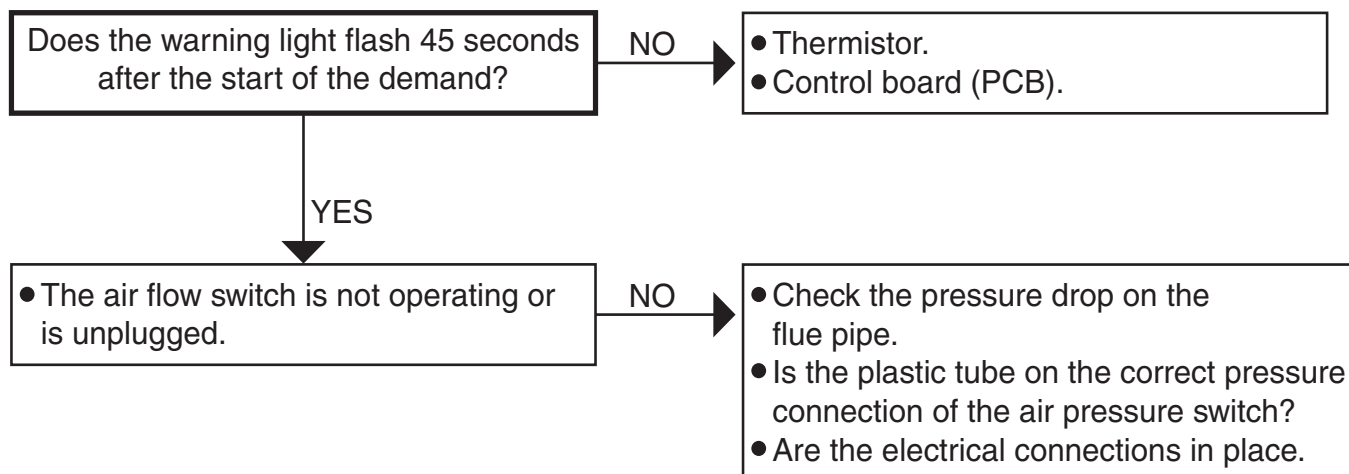

# 17 Wiring Diagram

10016

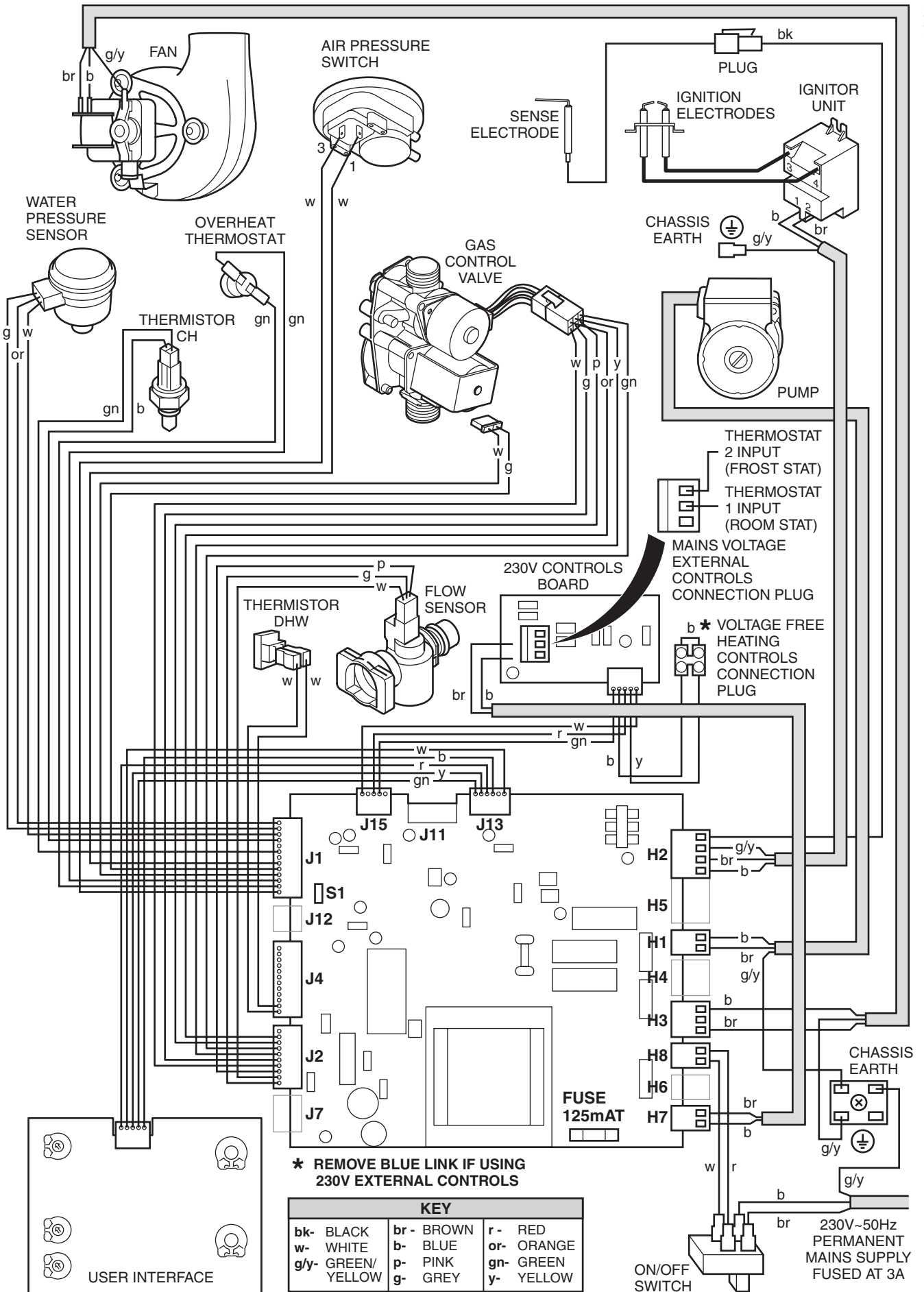

## 18 Replacement of Parts

### To Drain the central heating circuit

- Open drain valve fitted at the lowest point in the system.
- Allow air into the system by opening a radiator bleed screw or the boilers drain valve (a).

### To Drain the Domestic hot water circuit

- Close boiler isolating valve (c).
- Turn on one or more hot water taps.

### To Drain the boiler

- Close isolating screws on the isolating valves (b), (c) and (d) turn from vertical to horizontal to close.
- Open the boiler drain valve (a).
- Turn on one or more hot water taps.

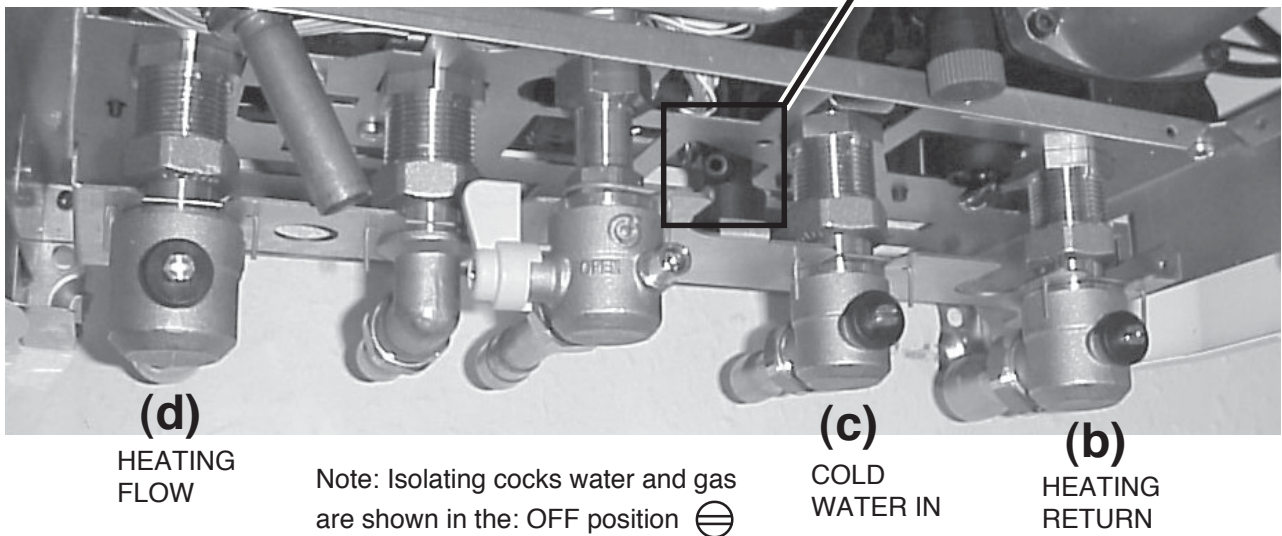
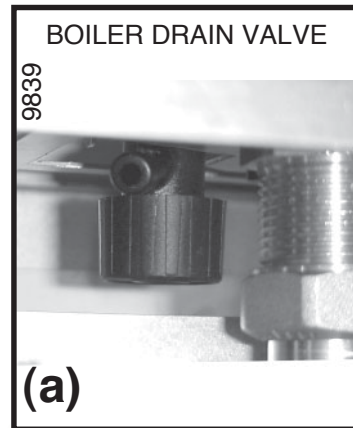

Diagram 18.1

## IMPORTANT INFORMATION

**WARNING:** Before commencing the replacement of any component, isolate appliance from electrical supply and turn off gas at service cock.

Replacement of parts must be carried out by a competent person.

When replacing components it may be necessary to renew sealing washers, gaskets and 'O' rings. If new ones are supplied with replacement components they must be used.

All parts are replaced in reverse order to removal.

If any gas-carrying components are disturbed, removed or replaced it will be necessary on completion to check for gas soundness with leak detection fluid.

### 18.1 Central heating thermistor

Before starting refer to the front of **Section 18 Important information**.

- Remove the front panel, refer to **Section 15.3**.
- Lower the control panel, refer to **Section 15.4**.
- Remove the sealed chamber cover, refer to **Section 15.5**.
- Locate central heating thermistor on the top left hand side of the heat exchanger, see **diagram 18.2**.

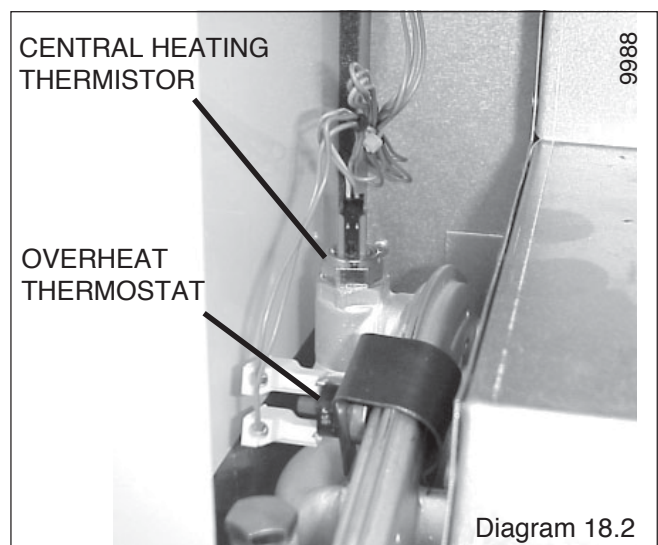

Diagram 18.2

- Disconnect electrical connections from thermistor.
- Remove the thermistor from the heat exchanger.
- Fit replacement thermistor.
- Refit electrical connections.

## 18 Replacement of Parts

### 18.2 Fan, refer to 'Section 15.10 Routine Cleaning and Inspection'.

### 18.3 Air pressure switch

Before starting refer to the front of **Section 18 Important information**.

- Remove the front panel, refer to **Section 15.3**.
- Lower the control panel, refer to **Section 15.4**.
- Remove the sealed chamber cover, refer to **Section 15.5**.
- Locate air pressure switch situated inside combustion chamber on top left hand side, see **diagram 18.3**.
- Remove air pressure switch tube from sensing probe on fan.
- Disconnect air pressure switch electrical connections.
- Unclip to remove air pressure switch.

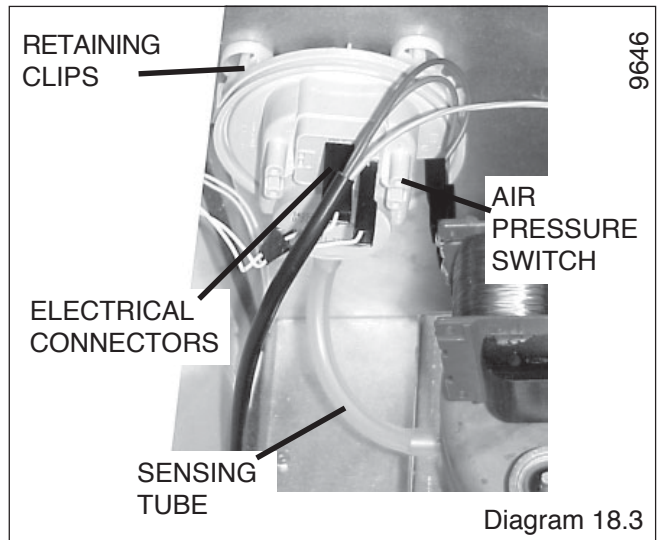

### 18.4 Domestic water inlet filter

Before starting refer to the front of **Section 18 Important information**.

If the water flow rate through the appliance has reduced it may be necessary to clean or replace the water inlet filter, refer to **section 15.12**.

### 18.5 Central Heating Filter

Before starting refer to the front of **Section 18 Important information**.

It may be necessary to clean or replace the central heating filter, refer to **section 15.13**.

### 18.6 Cold water inlet restrictor

Before starting refer to the front of **Section 18 Important information**.

- Remove the front panel, refer to **Section 15.3**.
  - Lower the control panel, refer to **Section 15.4**.
- Drain down domestic hot water circuit of boiler only, refer to **relevant part of diagram 18.1**.
- Remove the retaining wire.
  - Undo union nuts from boiler cold water in isolating valve.
  - Clean and inspect restrictor, replace if necessary, see **diagram 18.4**.

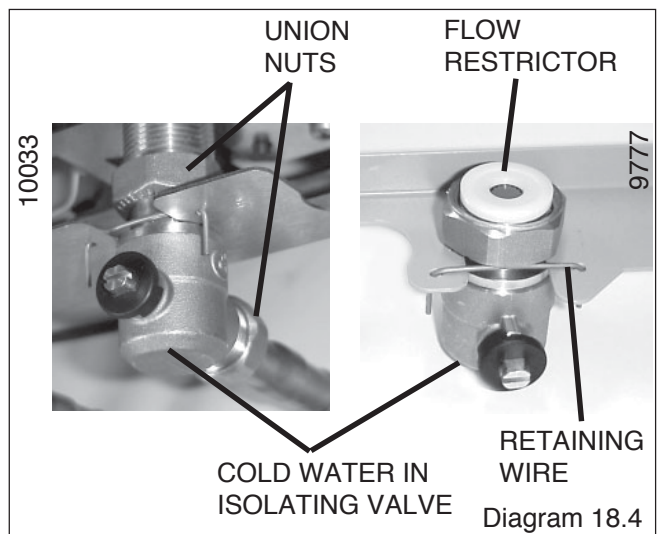

### 18.7 Burner, refer to Section 15.9.

Before starting refer to the front of **Section 18 Important information**.

### 18.8 Burner injectors, refer to diagram 18.5.

Before starting refer to the front of **Section 18 Important information**.

- Remove burner from boiler, refer to **Section 15.9**.
- Remove and replace injectors as required.

Note: The injectors may be cleaned, remove injectors inspect and clean. **Do not use a wire or sharp instrument**.

Note: Make sure that injector size, marked on each injector, is the same as that given in 'Section 1 Technical Data' for the type of gas being used.

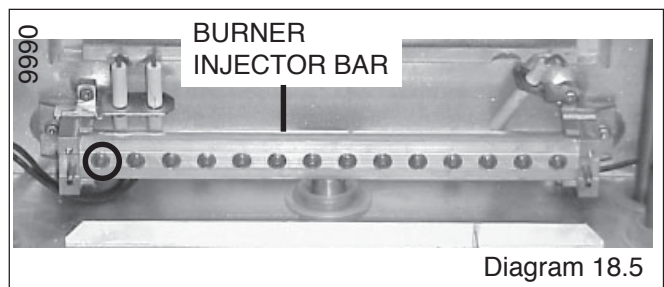

## 18 Replacement of Parts

### 18.9 Burner injector assembly, refer to diagram 18.6.

Before starting refer to the front of **Section 18 Important information**.

- Remove burner from boiler, **refer to Section 15.9**.
- Undo the gas supply union nut from under the sealed chamber.

Note: The fibre washer between the burner injector assembly and gas supply must be kept for use on reassembly.

- Undo and remove the sense and ignition electrode assemblies.
- Remove the burner injector assembly securing screws.
- Remove the burner injector assembly by lifting up, easing the gas connection through the grommet in the sealing chamber.
- When refitting burner injector assembly ensure the gas connection locates correctly through the grommet.

Note: Make sure that injector size, marked on each injector, is the same as that given in 'Section 1 Technical Data' for the type of gas being used.

### 18.10 Overheat thermostat

Before starting refer to the front of **Section 18 Important information**.

- Remove the front panel, **refer to Section 15.3**.
- Lower the control panel, **refer to Section 15.4**.
- Remove the sealed chamber cover, **refer to Section 15.5**.
- Locate overheat thermostat on left hand side of heat exchanger, **see part of diagram 18.8**.
- Disconnect electrical connections from thermostat
- Unclip thermostat from heat exchanger.
- When refitting electrical connections to replacement thermostat the polarity is not important.

### 18.11 Domestic hot water thermistor

Before starting refer to the front of **Section 18 Important information**.

- Remove the front panel, **refer to Section 15.3**.
- Lower the control panel, **refer to Section 15.4**.
- Locate domestic hot water thermistor on domestic hot water pipe to the left of centre of the boiler, **see part of diagram 18.7**.
- Disconnect electrical connections from thermostat
- Unclip thermostat from flow pipe to the heat exchanger.
- When refitting electrical connections to replacement thermostat the polarity is not important.

### 18.12 Ignition electrode

Before starting refer to the front of **Section 18 Important information**.

- Remove burner, **refer to Section 15.9**.
- Remove the left hand side panel, **refer to Section 15.6**.
- Undo and remove screw securing electrode assembly to the burner injector assembly, **see diagram 18.6**.
- Disconnect the electrical connections at the igniter unit, **see diagram 18.21**. Note the routing of the cables.

### 18.13 Flame sense electrode

Before starting refer to the front of **Section 18 Important information**.

- Remove burner, **refer to Section 15.9**.
- Remove the right hand side panel, **refer to Section 15.6**.
- Undo and remove screw securing sense assembly to the burner injector assembly, **see diagram 18.6**.
- Disconnect the electrical connection from the inline connector, Note the routing of the cable.

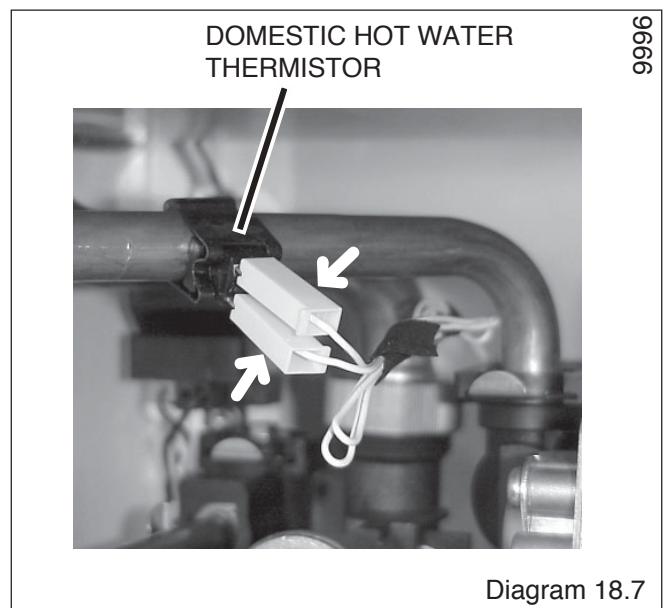
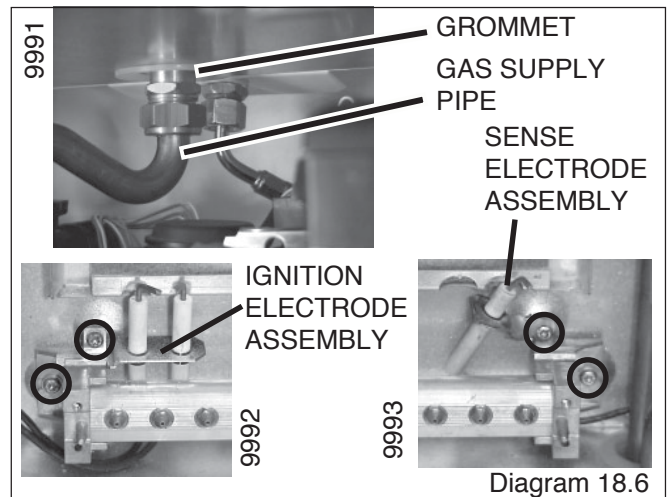

## 18 Replacement of Parts

### 18.14 Heat exchanger, refer to diagram 18.8.

Before starting refer to the front of **Section 18 Important information**.

- Remove the front panel, refer to **Section 15.3**.
- Lower the control panel, refer to **Section 15.4**.
- Remove the sealed chamber cover, refer to **Section 15.5**.
- Remove the combustion chamber cover, refer to **Section 15.7**.
- Drain down central heating water circuit and domestic hot water circuit of the boiler only, refer to relevant part of **diagram 18.1**.
- Remove the fan, refer to **Section 15.10**.
- Remove the flue hood, retained by two screws lift up and off.
- Remove the electrical leads from the overheat thermostat, refer to **diagram 18.8**.
- Disconnect the four union nuts.
- Lift to remove the heat exchanger taking care not to damage the insulation.

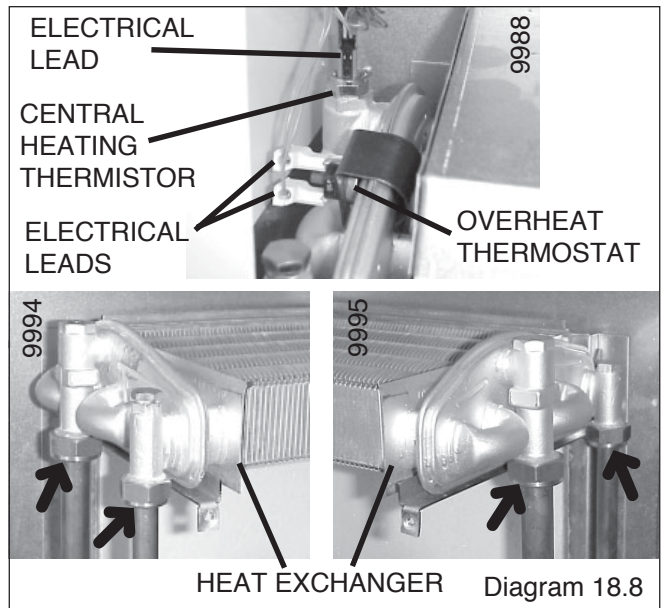

### 18.15 Combustion chamber insulation, refer to diagram 18.9.

Before starting refer to the front of **Section 18 Important information**.

- Remove the front panel, refer to **Section 15.3**.
- Lower the control panel, refer to **Section 15.4**.
- Remove the sealed chamber cover, refer to **Section 15.5**.
- Remove the combustion chamber cover, refer to **Section 15.7**.
- Remove the heat exchanger, refer to **Section 18.14**.
- Carefully bend back side insulation retaining tabs, pull out side and front insulation panels from combustion chamber.
- Tilt rear insulation panel forwards slide up and out.
- Fit replacement insulation.

### 18.16 Printed circuit board (PCB), refer to diagram 18.10.

Before starting refer to the front of **Section 18 Important information**.

- Remove the front panel, refer to **Section 15.3**.
- Lower the control panel, refer to **Section 15.4**.
- Gain access to rear of control panel.
- Undo and remove the two cover retaining screws. This will disconnect the metal plate heat reflector.
- Hinge up the control panel cover and ease forwards from the rear retaining lugs to gain access to PCB. Do not strain the cables attached to the PCB. Note the routing of the cables.
- Carefully pull off electrical connections to PCB.
- Unclip and lift out PCB.
- Fit replacement PCB in reverse order to removal. Be careful not to trap any of the cables.

Make sure that PCB connections are fully pushed onto replacement PCB.

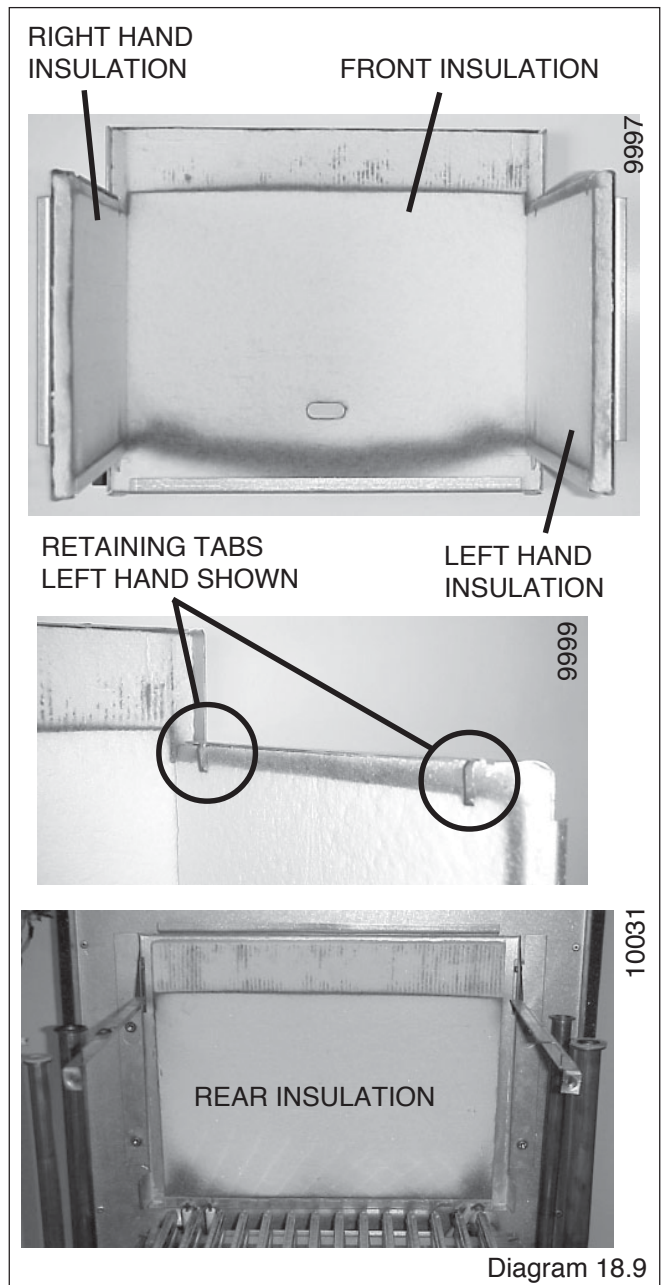

## 18 Replacement of Parts



10000

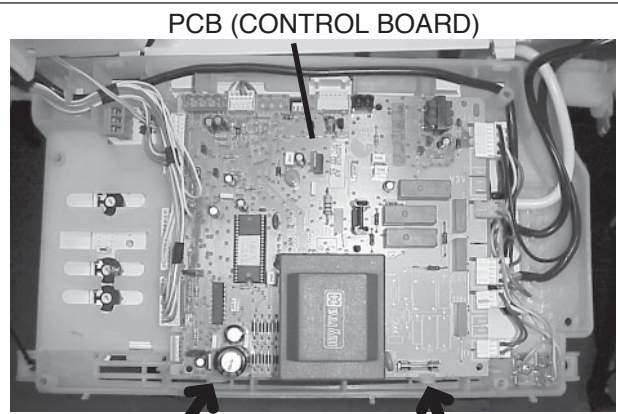

10001

Diagram 18.10

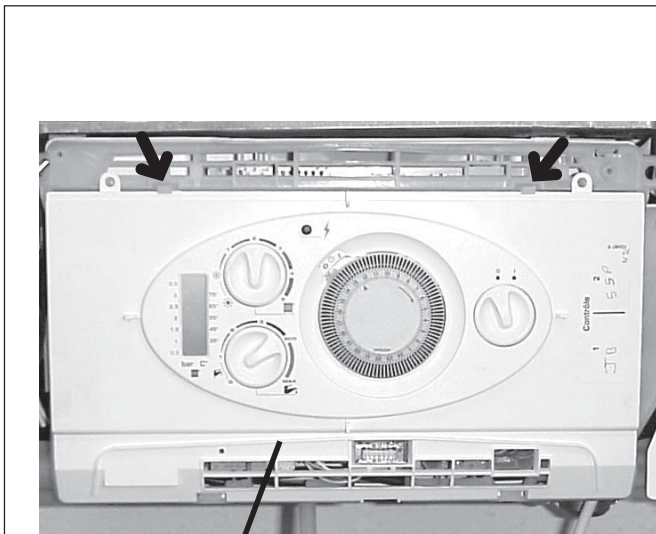

9762

CONTROL PANEL

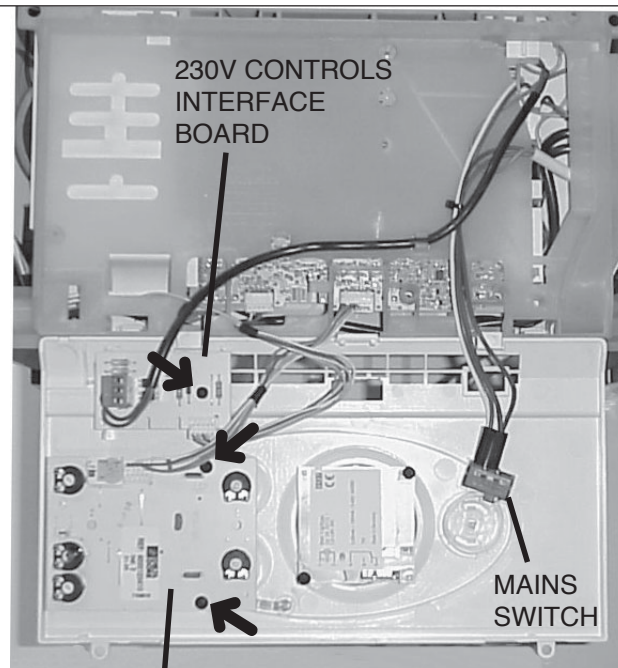

10019

USER INTERFACE BOARD

Diagram 18.11

### 18.17 User interface board, refer to diagram 18.11.

Before starting refer to the front of **Section 18 Important information.**

- Remove the front panel, refer to **Section 15.3.**
- Lower the control panel, refer to **Section 15.4.**
- Unclip control panel user interface and hinge forward . Do not strain the cables.
- Disconnect the electrical connections from the user interface board.
- Remove the two user interface board retaining screws.
- Remove the user interface board.

### 18.18 Mains switch, see diagram 18.11.

Before starting refer to the front of **Section 18 Important information.**

- Remove the front panel, refer to **Section 15.3.**
- Lower the control panel, refer to **Section 15.4.**

- Unclip control panel user interface and hinge forward . Do not strain the cables.

- Disconnect the electrical connections from the mains switch.
- Remove and replace the mains switch.

### 18.19 230V Controls board, refer to diagram 18.11.

Before starting refer to the front of **Section 18 Important information.**

- Unclip control panel user interface and hinge forward . Do not strain the cables.
- Disconnect the electrical connection from the 230V controls board and the electrical connection from printed circuit board (PCB).
- Remove the 230V controls board retaining screw.
- Remove the 230V controls board.

## 18 Replacement of Parts

### 18.20 Central heating pump head, refer to diagram 18.12.

Before starting refer to the front of **Section 18 Important information**.

- Remove the front panel, refer to **Section 15.3**.
- Lower the control panel, refer to **Section 15.4**.
- Drain down central heating water circuit of the boiler only, refer to relevant part of **diagram 18.1**.

Note: it is not necessary to drain down the entire heating system to carry out this work.

- For ease of access if required remove the right hand side panel, refer to **Section 15.6**.
- Undo four fixing screws and remove pump head.
- Gain access to the pump electrical connection box and remove cover.
- Disconnect pump cable from pump (avoid straining cables).
- Connect electrical connection to replacement pump head.
- Fit replacement pump head in reverse order to removal.
- Check for leaks.

### 18.21 Filling system tap, refer to diagram 18.13.

Before starting refer to the front of **Section 18 Important information**.

- Remove the front panel, refer to **Section 15.3**.
- Lower the control panel, refer to **Section 15.4**.
- Drain down the boiler only, refer to relevant part of **diagram 18.1**.
- Pull out slotted metal clip securing tap into housing, remove tap.
- Pull out slotted metal clip and remove pipe from tap.

### 18.22 Reduced pressure zone valve (RPZ), refer to diagram 18.13.

Before starting refer to the front of **Section 18 Important information**.

- Remove the front panel, refer to **Section 15.3**.
- Lower the control panel, refer to **Section 15.4**.
- Drain down the boiler only, refer to relevant part of **diagram 18.1**.
- Pull out slotted metal clip securing pipe to RPZ.
- Pull out slotted metal clip securing RPZ into housing, remove RPZ.

### 18.23 Boiler drain point, refer to diagram 18.14.

Before starting refer to the front of **Section 18 Important information**.

- Remove the front panel, refer to **Section 15.3**.
- Lower the control panel, refer to **Section 15.4**.
- Drain down the boiler only, refer to relevant part of **diagram 18.1**.

Pull out slotted metal clip securing boiler drain valve into housing, remove boiler drain valve.

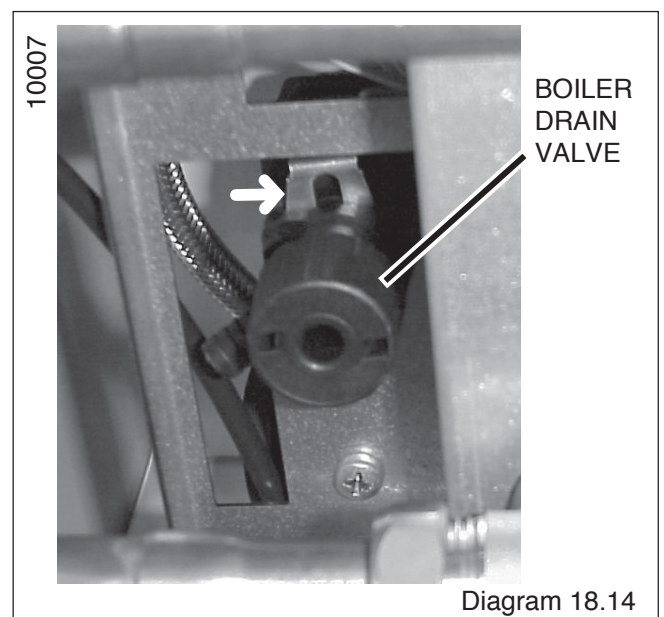
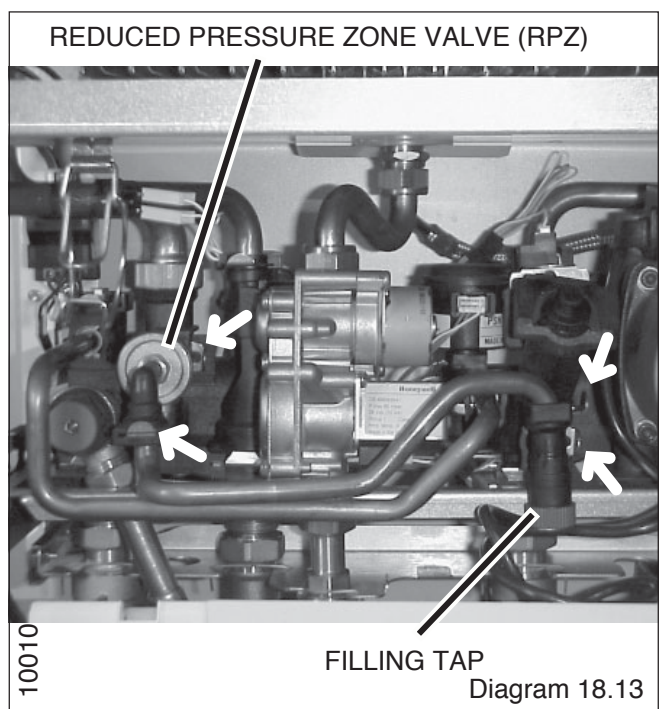
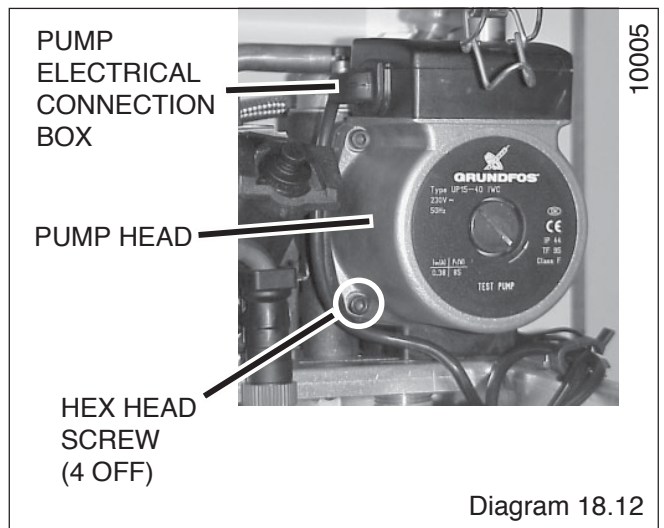

## 18 Replacement of Parts

### 18.24 Water flow sensor, refer to diagram 18.15.

Before starting refer to the front of **Section 18 Important information.**

- Remove the front panel, refer to **Section 15.3.**
- Lower the control panel, refer to **Section 15.4.**

Drain down the boiler, refer to relevant part of **Section 18.1.**

- Undo the union on the cold water inlet isolating tap.
- Pull out slotted metal clip securing filling system tap into housing, swing the tap forwards.
- Pull out the two slotted metal clips retaining the domestic water inlet filter housing.
- Remove domestic water inlet filter housing.
- Remove electrical connections from water flow sensor.
- Pull off slotted metal clip and remove water flow sensor.

### 18.25 System water pressure sensor, refer to diagram 18.16.

Before starting refer to the front of **Section 18 Important information.**

- Remove the front panel, refer to **Section 15.3.**
  - Lower the control panel, refer to **Section 15.4.**
- Drain down the boiler, refer to relevant part of **Section 18.1.**
- Remove electrical connections from water pressure sensor.
  - Pull off slotted metal clip and remove water pressure sensor.

### 18.26 Bypass valve, refer to diagram 18.17.

Before starting refer to the front of **Section 18 Important information.**

- Remove the front panel, refer to **Section 15.3.**
- Lower the control panel, refer to **Section 15.4.**

Drain down the boiler, refer to relevant part of **Section 18.1.**

Pull out slotted metal clip and remove bypass valve.

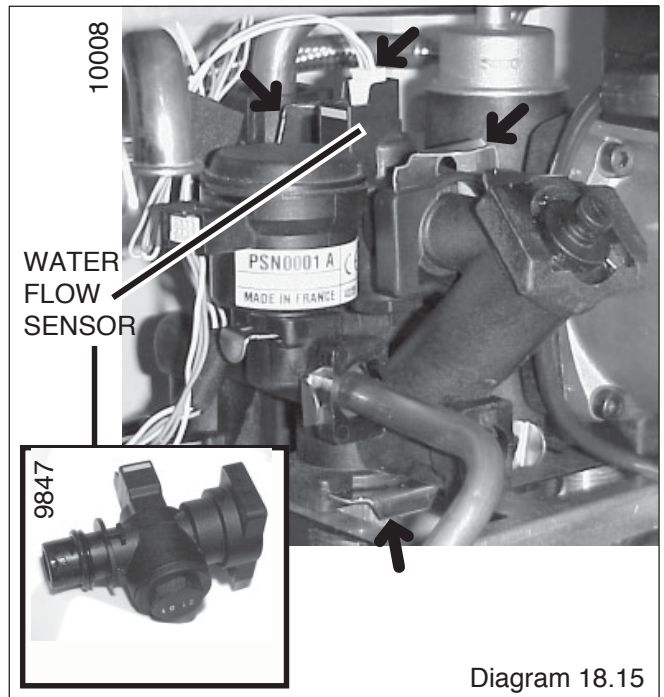

Diagram 18.15

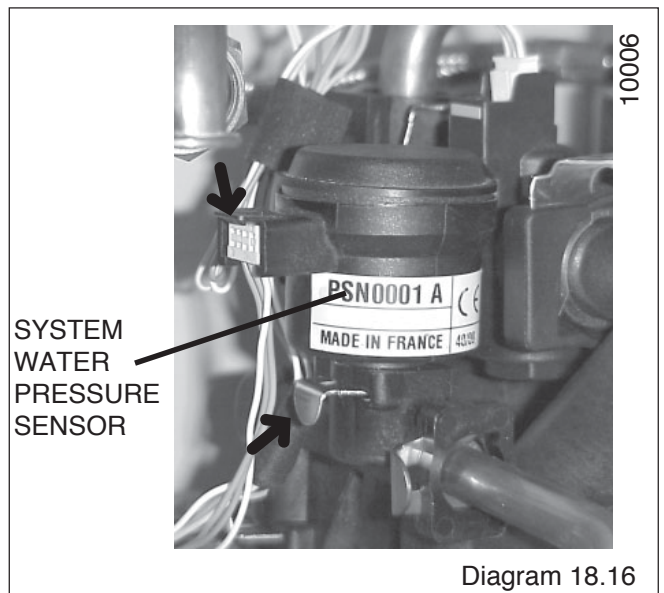

Diagram 18.16

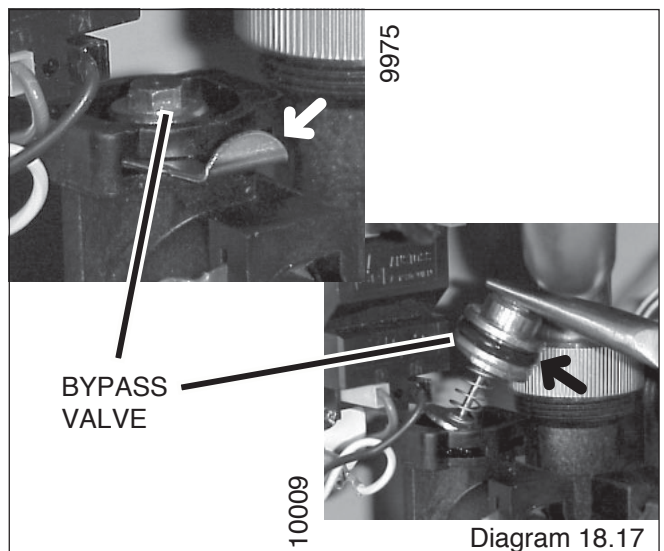

Diagram 18.17

## 18 Replacement of Parts

### 18.27 Automatic air vent, refer to diagram 18.18.

Before starting refer to the front of **Section 18 Important information**.

- Remove the front panel, refer to **Section 15.3**.
- Lower the control panel, refer to **Section 15.4**.
- Drain down the boiler only, refer to relevant part of diagram 18.1.
- Unscrew to remove automatic air vent.
- After fitting replacement automatic air vent ensure the cap is open.

### 18.28 Gas Control valve, refer to diagram 18.19.

Before starting refer to the front of **Section 18 Important information**.

- Remove the front panel, refer to **Section 15.3**.
- Lower the control panel, refer to **Section 15.4**.
- Disconnect gas supply pipe union nuts at the gas control valve.
- Disconnect injector supply pipe union nut at the gas control valve. Slacken the union nut at the burner injector bar.
- Remove gas control valve retaining clip from the underside of gas control valve.
- Ease gas control valve forwards and disconnect electrical connections to gas control valve.

**Note:** The washers must be kept for use on reassembly.

- Withdraw gas control valve assembly.
- After fitting replacement gas control valve test for gas soundness.

### 18.29 Gas control valve stepper motor

Before starting refer to the front of **Section 18 Important information**.

- Remove the front panel, refer to **Section 15.3**.
- Lower the control panel, refer to **Section 15.4**.
- Disconnect the electrical connection from stepper motor, see diagram 18.19.
- Remove the two screws securing stepper motor to the gas control valve, see diagram 18.20.
- Fit replacement gas control valve stepper motor.
- Note: Take care not to damage the 'O' ring.

### 18.30 Discharge safety valve, refer to diagram 18.21.

Before starting refer to the front of **Section 18 Important information**.

- Remove the front panel, refer to **Section 15.3**.
- Lower the control panel, refer to **Section 15.4**.
- Undo discharge pipe union nut.
- Pull out slotted metal clip from valve body and remove valve.

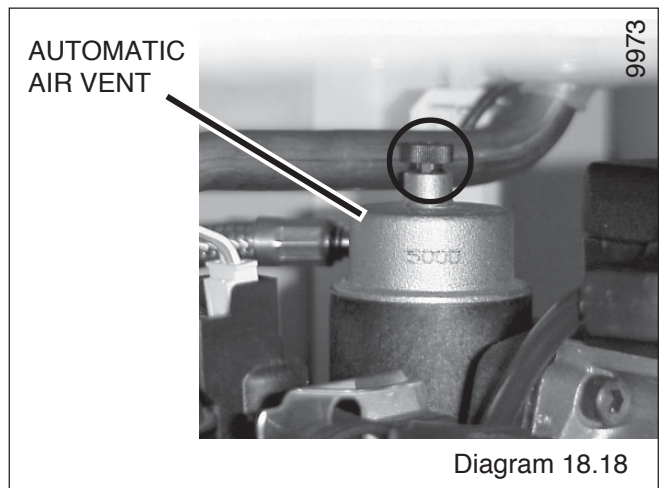

Diagram 18.18

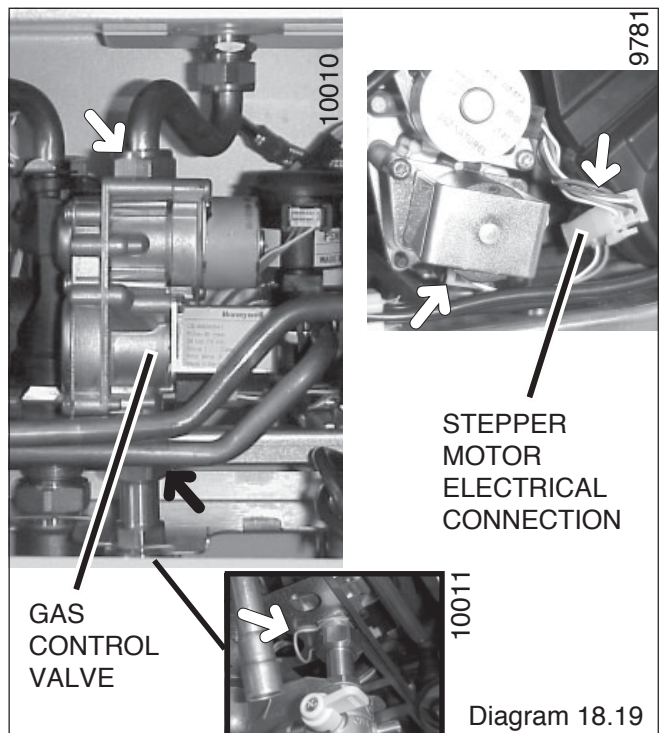

Diagram 18.19

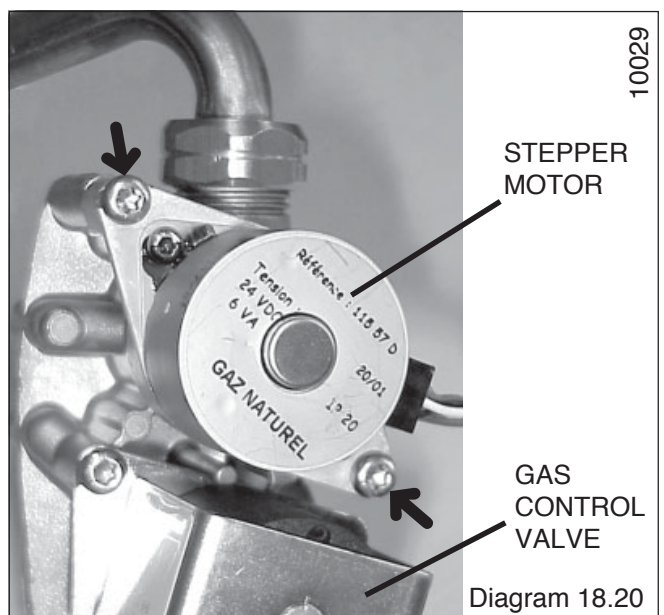

Diagram 18.20

## 18 Replacement of Parts

### 18.31 Igniter unit, refer to diagram 18.22.

Before starting refer to the front of **Section 18 Important information**.

- Remove the front panel, refer to **Section 15.3**.
- Lower the control panel, refer to **Section 15.4**.
- For ease of access remove the left hand side panel, refer to **Section 15.6**.
- Disconnect electrical connections.
- Remove ignition unit securing screw.
- Pull upwards to release and remove the ignition unit from the retaining slot.

### 18.32 Expansion vessel, refer to diagram 18.23.

Before starting refer to the front of **Section 18 Important information**.

• **IMPORTANT:** With regards to the manual handling operations, 1992 regulations, the following operation exceeds the recommended weight for one man lift.

Renewal of the expansion vessel requires the boiler to be removed from the wall. As an alternative, a separate expansion vessel of the same specification may be connected as close as possible to the boiler, leaving the original in position, refer to the installation instructions.

- Remove the front panel, refer to **Section 15.3**.
- Lower the control panel, refer to **Section 15.4**.
- Disconnect the mains cable and any external controls cables.
- Drain down the boiler only, refer to relevant parts of **diagram 18.1**.
- For this operation the boiler must be removed from the wall.
- Disconnect the flue system.
- Disconnect the union connections at the fixing jig.
- Disconnect the pressure relief valve discharge pipe.
- Lift up to remove the boiler from the wall.
- From the rear of the boiler. Undo pipe coupling on expansion vessel.
- Undo and remove expansion vessel retaining nut.
- Slide expansion vessel up to remove.

Note: Check that expansion vessel pressure is correct, see **'Section 1 Technical Data'**.

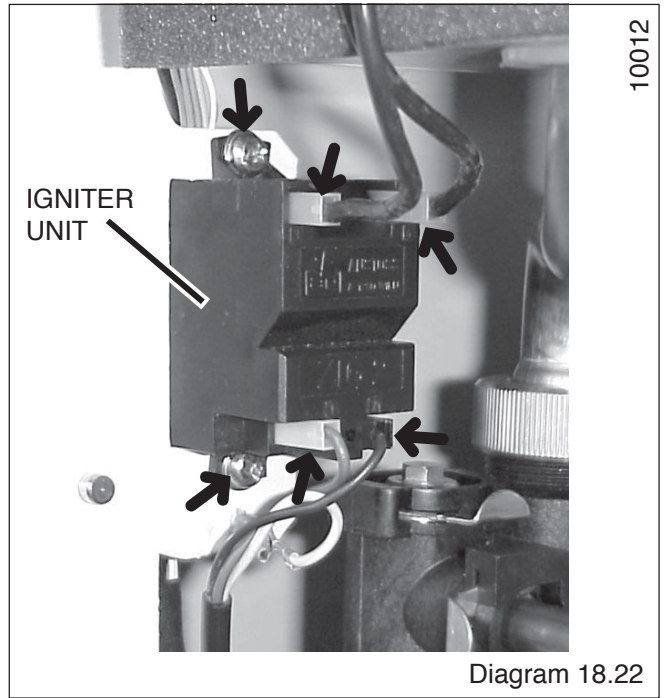

Diagram 18.22

10012

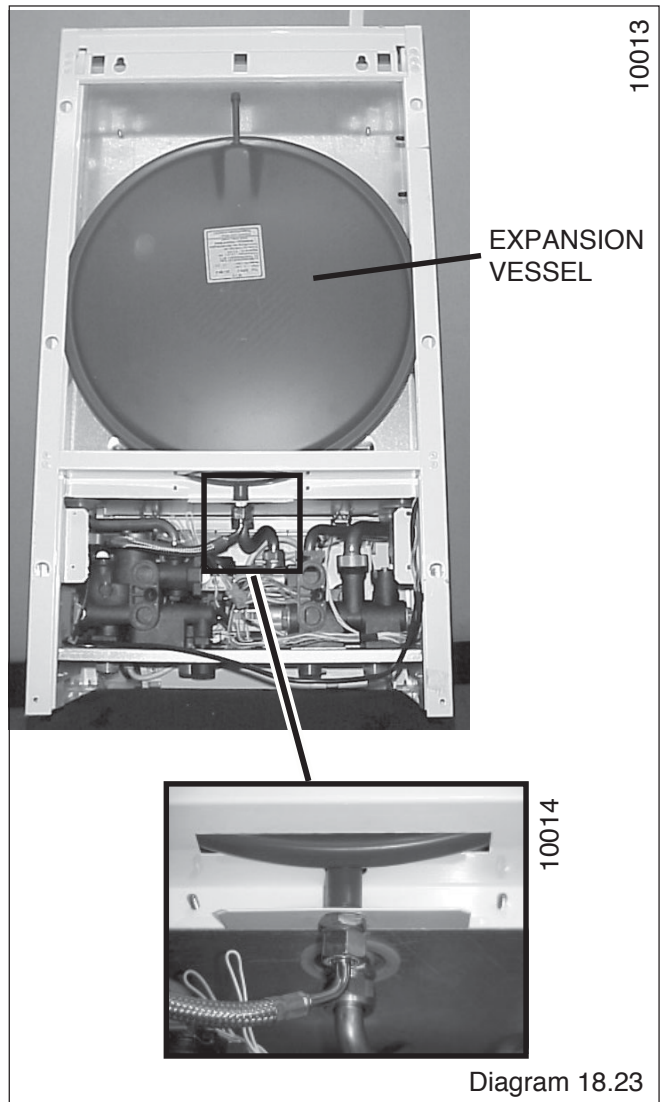

Diagram 18.23

10013

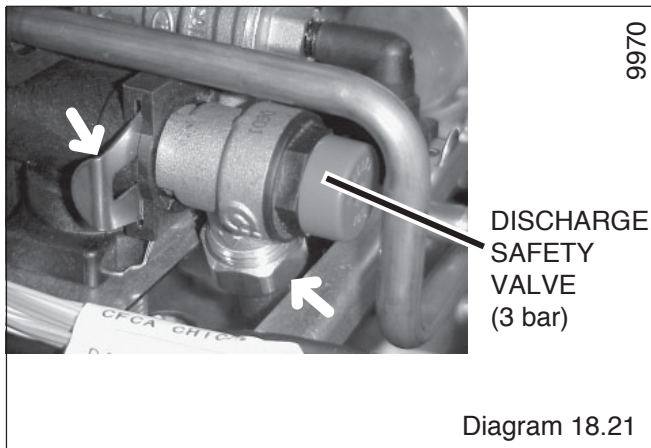

Diagram 18.21

9970

10014

## 19 Spare Parts

When ordering spare parts, quote the part number and description, stating the appliance model number and serial number from the data badge.

### Short parts list

No.	Description	Part No.	G.C. No.
1	Central heating thermistor	801933	
2	Fan	801926	
3	Air pressure switch	801928	
4	Domestic water flow sensor	801910	
5	Printed circuit board - Main	801915	
6	Pump head	801896	
8	System water pressure sensor	801911	
9	Gas control valve	801911	
10	Discharge safety valve	801904	
11	Overheat thermostat	801927	
12	Ignition electrode	801888	
13	Flame sense electrode	801887	
14	230V controls board		
15	User interface PCB	801914	
16	Stepper motor	801892	
17	Ignitor unit		
18	Pressure releif valve	801094	
19	Heat exchanger		
20	Burner		

*Because of our constant endeavour for improvement details may vary slightly from those in the instructions.*