Wall hung, fan flue, room sealed, high efficiency gas boiler

Service manual

ActivA

Models: G.C. Appl. No.

Activ A 12OV

Activ A 15OV

Activ A 20OV

Activ A 25OV

Leave this manual adjacent to the gas meter

Warning

Service / repairs must be carried out, only by a qualified Gas Safety Registered Engineer, who will be responsible for the current Regulations for gas appliances.

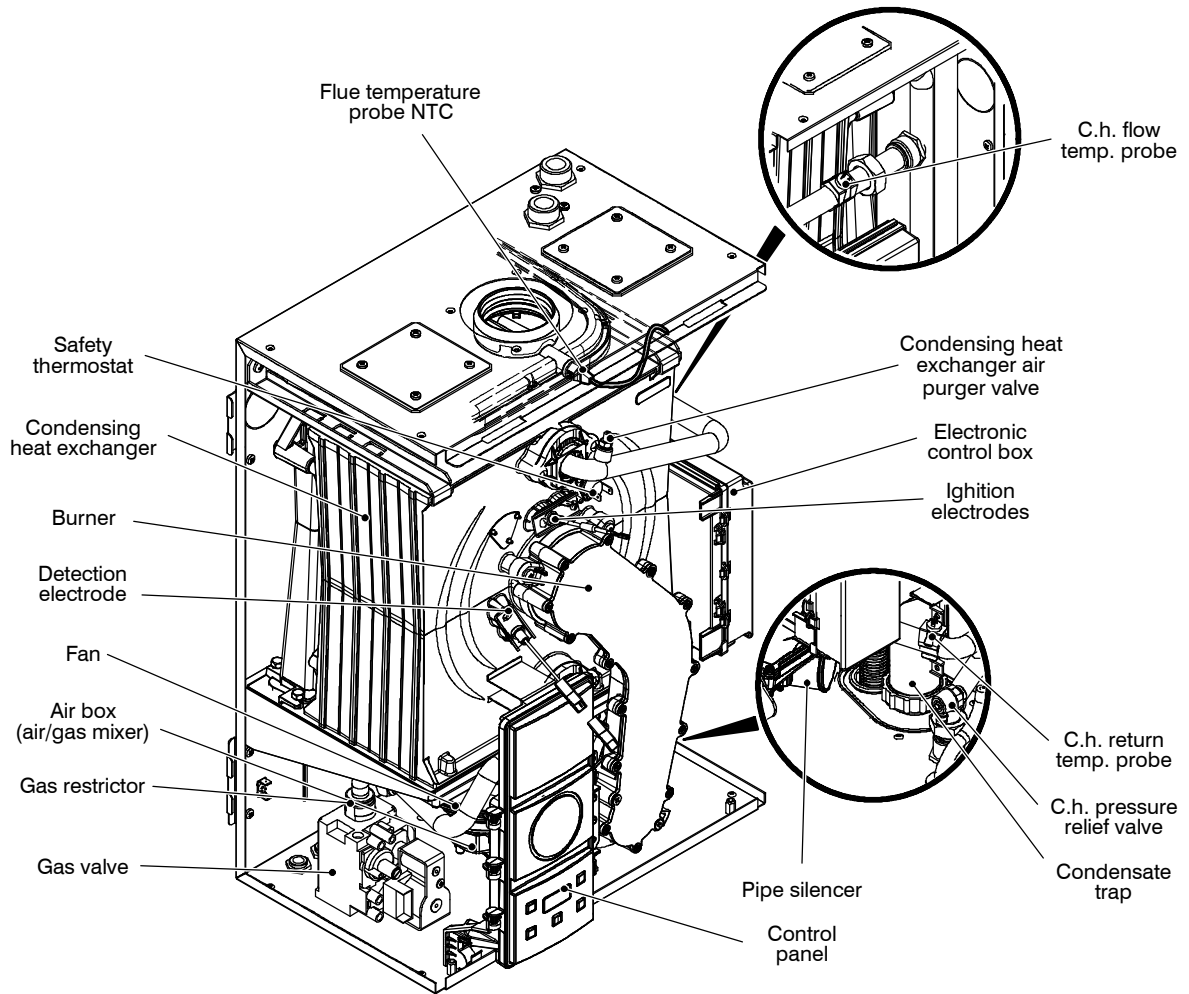

Table of contents

1	Overall information	1	8	Gas valve	21
1.1	Overall View	1	8.1	Function	21
1.2	Hydraulic diagram	1	8.2	Description of the parts	21
2	General access and emptying hydraulic circuits	2	8.3	Adjustment	21
2.1	Nomenclature	2	8.4	Checks	23
2.2	Case panels	2	8.5	Removal of the gas valve	23
2.3	Control panel	2	9	Temperature probe	25
2.4	Main electronic p.c.b. box	3	9.1	Function	25
2.5	Emptying the primary circuit	4	9.2	Checks	25
3	Diagrams	5	9.3	Removal of the c.h flow temp. probe	25
3.1	Wiring diagram	5	9.4	Removal of the c.h. return temp. probe	25
3.2	Circuit voltages	6	10	Fan and Air box	27
4	Fault finding	7	10.1	Function	27
4.1	Display diagnostic	9	10.2	Removal of the Fan and the Air box	27
5	Condensing heat exchanger	10	11	Ignition and detection electrodes and burner	28
5.1	Function	10	11.1	Function	28
5.2	Removal	10	11.2	Removal of the Ignition and detection electrodes	28
5.3	Cleaning	11	11.3	Removal of the burner	28
6	Main electronic control/ignition p.c.b.	12	11.4	Checks	28
6.1	Function	12	12	Safety thermostat	30
6.2	Selection and adjustment devices	12	12.1	Function	30
6.3	Checking the temperature	13	12.2	Checks	30
6.4	Setting the boiler control function modes	13	12.3	Removal	30
6.5	Checks	15	13	Flue temperature probe NTC and Safety thermal fuse	31
6.6	Removal of the electronic control p.c.b.	15	13.1	Function	31
6.7	Thermal control in the "c.h." mode	17	13.2	Removal	31
7	Control panel electronic p.c.b.	18	13.3	Checks	31
7.1	Function	18	14	Condensate trap	32
7.2	Normaly information	18	14.1	Function	32
7.3	Info modality	19	14.2	Check the cleanness of the trap	32
7.4	Function modes setting modality	19	14.3	Removal	32
7.5	Removal of the control panel electr. p.c.b	19	15	Short spare parts list	33

1 Overall information

1.1 Overall View



1.2 Hydraulic diagram

Central heating (c.h.) operation

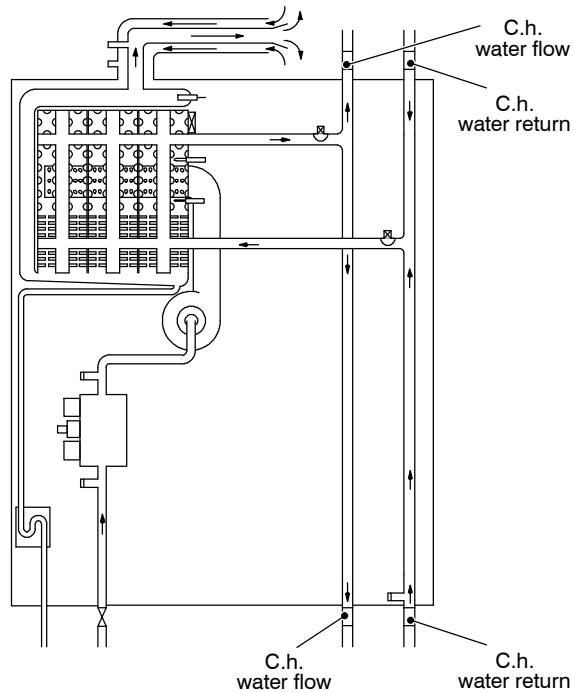

2 General access and emptying hydraulic circuits

2.1 Nomenclature

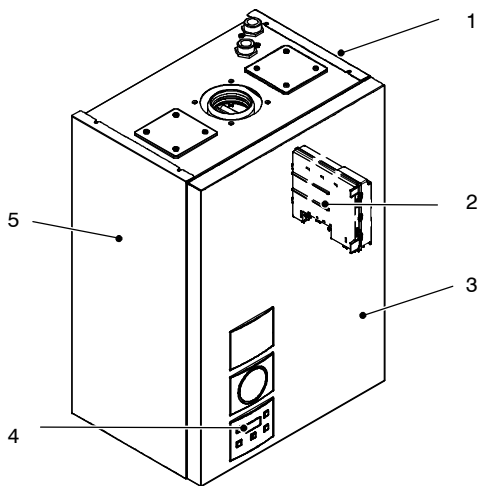

Fig. 2.1

- 1 Right side panel
- 2 Main electronic p.c.b. box
- 3 Front panel
- 4 Control panel
- 5 Left side panel

2.2 Case panels

Warning: isolate the boiler from the mains electricity supply before removing any covering or component.

For the most part of the check and maintenance operations it is necessary to remove one or more panels of the case.

The side panels can be removed only after the removal of the front panel.

To remove the front panel loosen screws A (Fig. 2.2).

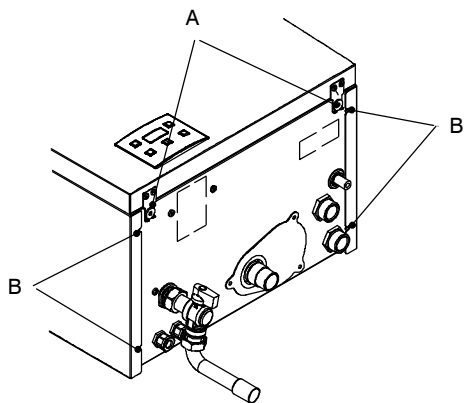

Fig. 2.2 – bottom view of the boiler

Pull the lower part of the front panel and lift it upwards (Fig. 2.3).

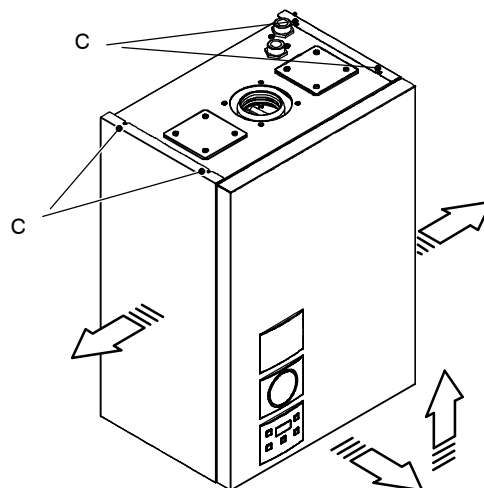

Fig. 2.3

To remove the side panels loosen the screws B (Fig. 2.2) and C (Fig. 2.3).

Pull the side panels towards the outside.

To Fit the case panels

Fit the side case panels

Warning:

Fit the front panel hooking it on the upper side.

Push the front case panel until it is completely hold in place (Fig. 2.4).

Ensure that the front panel edge is close-fitting to the side panels.

Lock in place the panel with the appropriate screws.

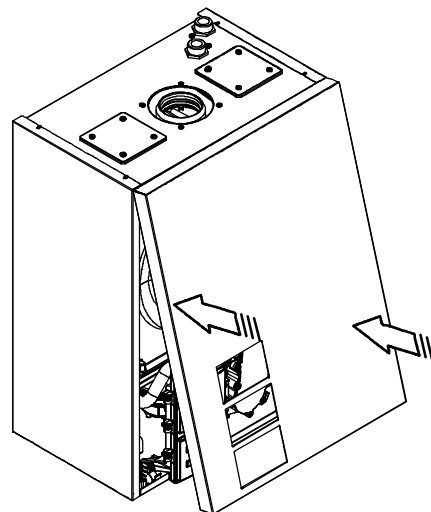

Fig. 2.4

2.3 Control panel

Warning: isolate the boiler from the mains electricity supply before removing any covering or component.

To gain access to the parts located inside the control panel proceed as follows:

- 1 Remove the front panel of the case.
- 2 Unscrew the screw D (Fig. 2.5)

- Free the hooks indicated and rotate the lid towards left (Fig. 2.5).

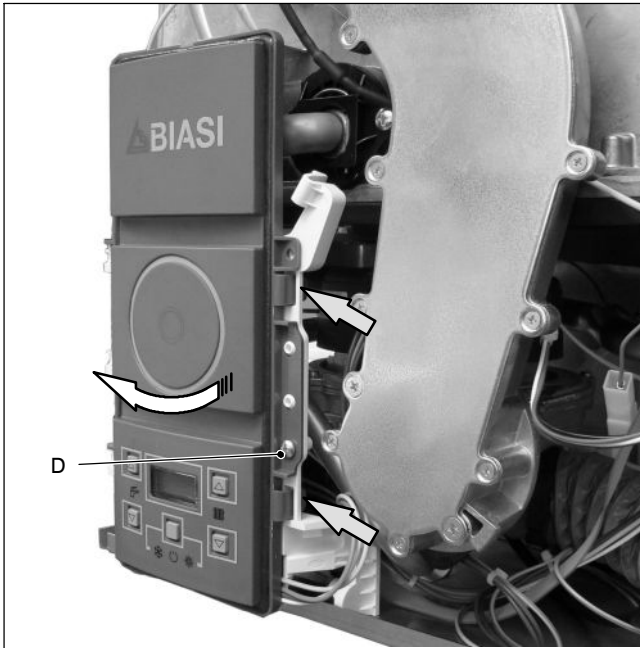

Fig. 2.5

- To access to the parts located inside the control panel turn it as shown in Fig. 2.6.

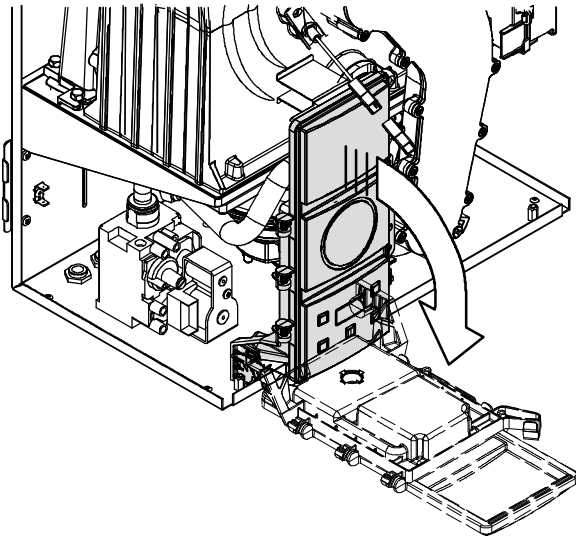

Fig. 2.6

2.4 Main electronic p.c.b. box

Warning: isolate the boiler from the mains electricity supply before removing any covering or component.

To gain access to the parts located into main electronic p.c.b. box proceed as follows:

- Remove the front panel of the case.

Terminal block lid removal

- To remove the terminal block lid *E* (Fig. 2.7), free the front hooks.

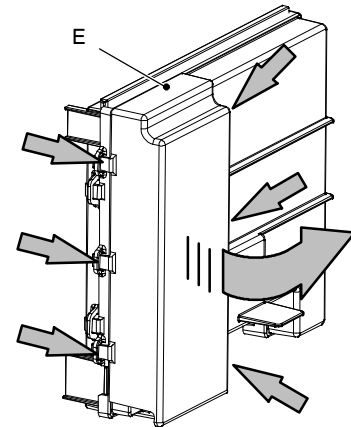

Fig. 2.7

- Slightly rotate the lid as indicated by the curved arrow and free the rear hooks.
- Remove the lid.

Main electronic p.c.b. lid removal

To get access to the main electronic p.c.b.:

- Pull the box that contains the electronic p.c.b. and rotate it (Fig. 2.8).

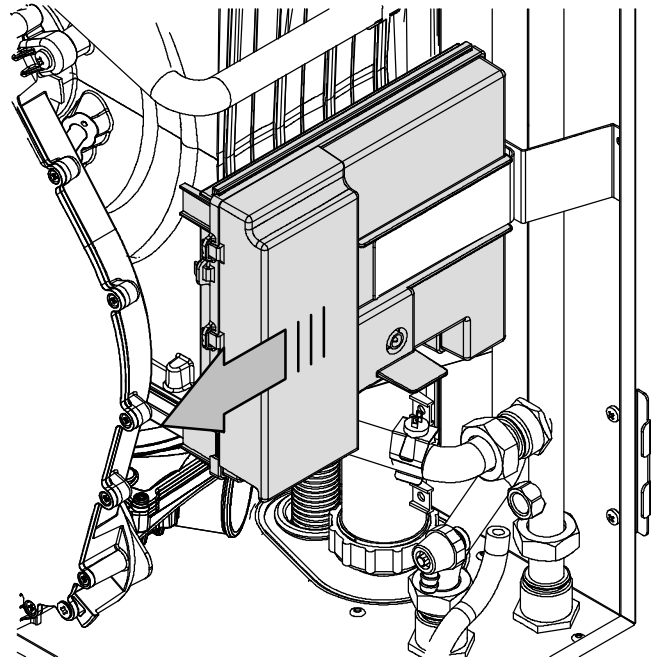

Fig. 2.8

- Remove the terminal block lid *E* (Fig. 2.7).
- Free the hooks placed on the three sides indicated and rotate the lid towards left (Fig. 2.9).

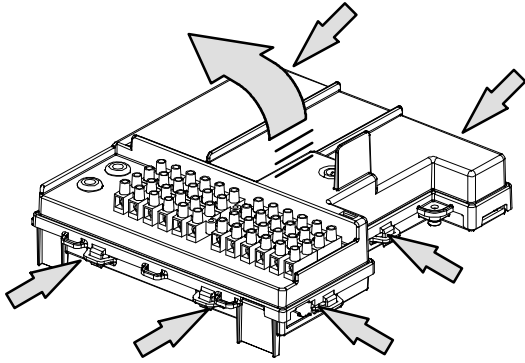

Fig. 2.9

2.5 Emptying the primary circuit

- 1 Close the c.h. circuit flow and return cocks.
- 2 Remove the front and right panels of the boiler.
- 3 Open the drain tap *F* (Fig. 2.10) until the boiler is completely emptied.

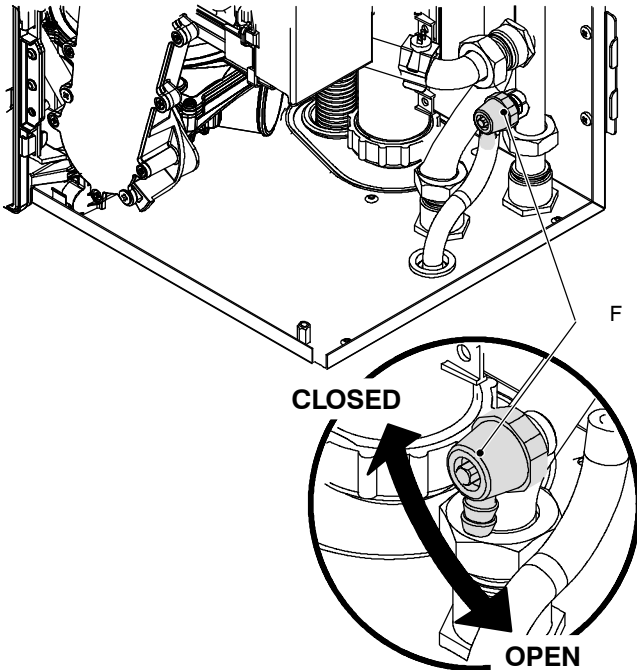

Fig. 2.10

- 4 To help the draining of the primary circuit loose the condensing heat exchanger air purger valve *G* (Fig. 2.11)

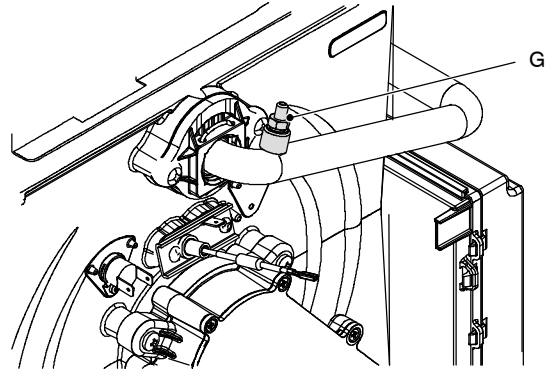

Fig. 2.11

Attention: some water could remain in the condensing heat exchanger.

- 5 Close drain tap once the emptying has been completed.

3 Diagrams

3.1 Wiring diagram

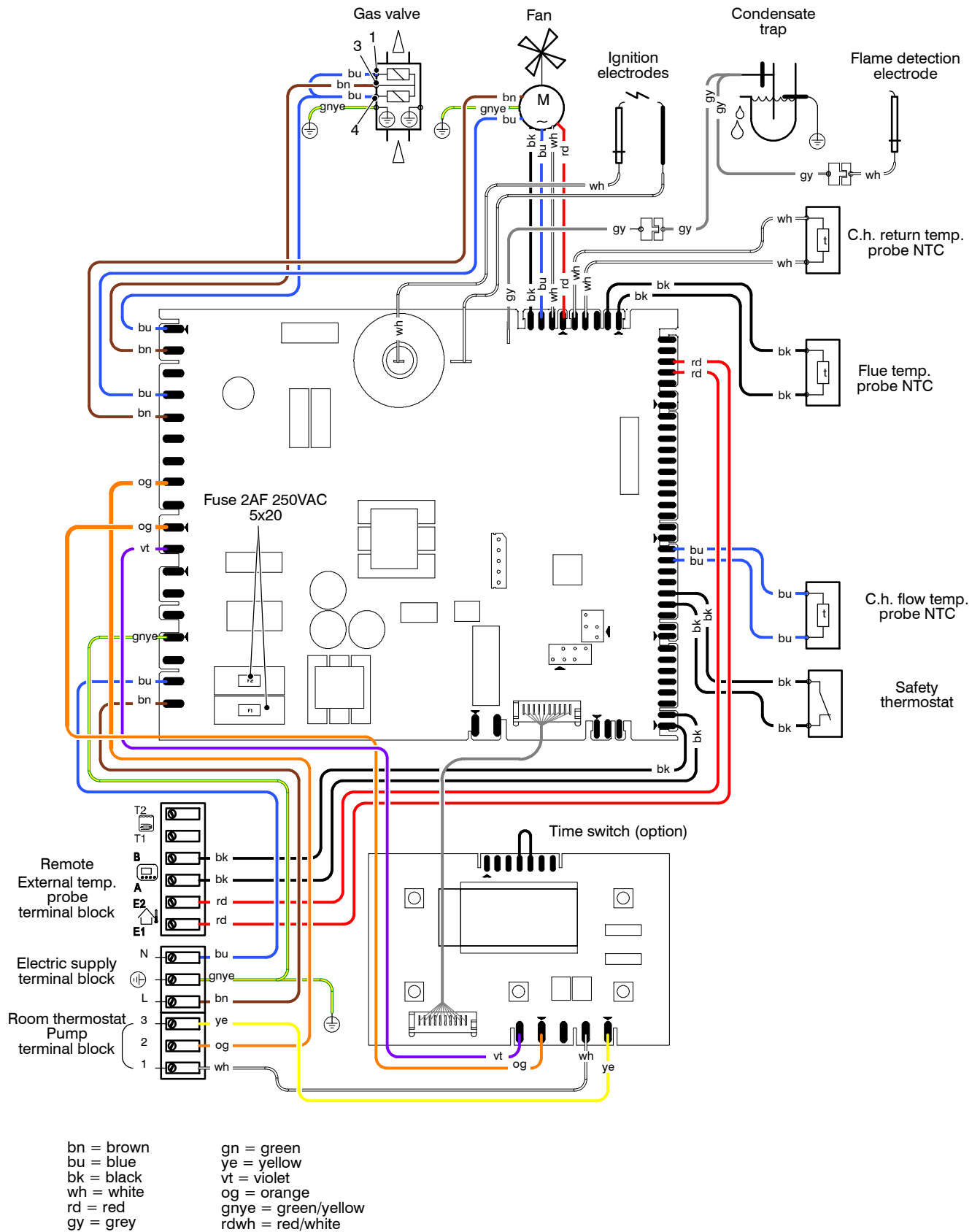

3.2 Circuit voltages

Electrical voltages with burner on — during c.h. operation

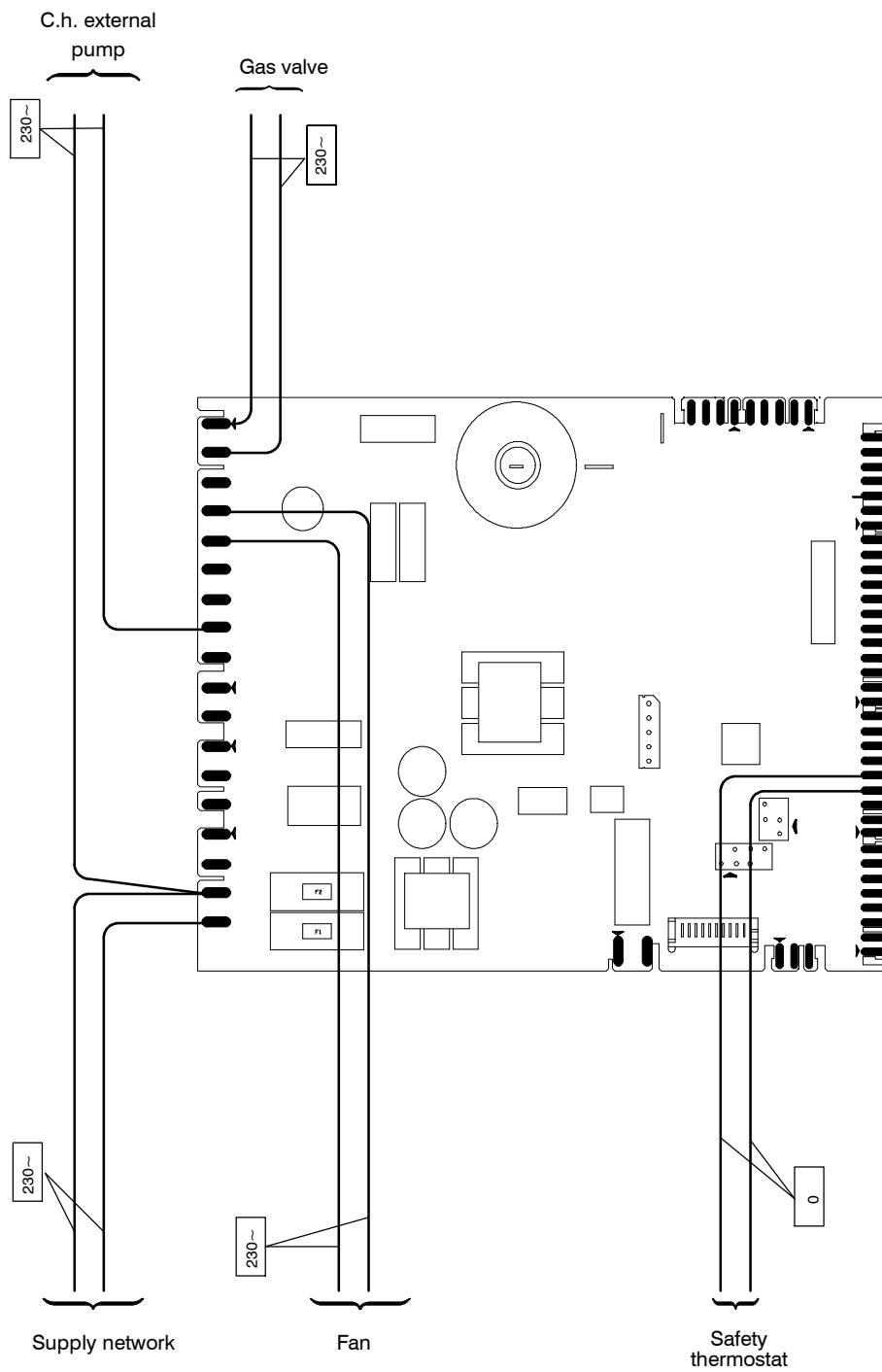

Section of the manual → (note ref. in brackets)	Components to check																						
	(1)	(2)	(3)	14.1	(4)	5	External pump	6.5	7	8.4	9.2	10	11.4	12.2	12.2	13.1	(7)	(1)	(1)	(1)	(1)		
Defect ↓																							
Appliance lock-out (*)																							
The boiler does not start. The control panel display OFF Fan still.	■						■	■	■														
Incorrect modulation								■				■											
Noisy boiler							■					■											
Water leaks from the safety valve during operation on c/h																					■		■
Water leaks from the safety valve when the boiler is off.																						■	■

* Lock out is indicated as "Er" on the display.

Note

Useful information can be obtained also from the optical indication given by the appliance display (see section 4.1).

- 1 Check for 230V~ between line (L) and neutral (N)

- 2 Verify the integrity of supply cable, plug and external fuses. Check the polarity of line and neutral connection

- 3 Check the gas supply pipe and isolation tap for gas tightness. Check for soundness and absence of obstructions. Verify that the flue terminal is correctly installed (see clearances) and ensure that exhaust gas is not sucked back by the boiler.

- 4 Check for soundness of the circuit and verify its correct filling (see also installation manual).

- 5 Verify the integrity of supply cable, plug and external fuses. Check the polarity of line and neutral connection

- 6 Check the gas supply pipe and isolation tap for gas tightness. Check for soundness and absence of obstructions. Verify that the flue terminal is correctly installed (see clearances) and ensure that exhaust gas is not sucked back by the boiler.

- 7 Check for soundness of the circuit and verify its correct filling (see also installation manual).

- 8 A jammed by-pass could cause the over-heating of the main circuit and the intervention of the safety thermostat.

- 9 Using the flue analyzer, check the CO₂ value of the flue gases. This reading is a reference value for the gas valve setting.

- 10 Check the pressurization of the expansion vessel. Refer to the installation manual for proper values.





- 11 The boiler doesn't reach the nominal heat input.

4.1 Display diagnostic

The display indications provide help in the diagnosis of fault finding.

The control panel display gives other information for the user.

The following table gives fault code, error and the reason for the fault.

Er 01 + RESET	Lack of burner ignition
Er 02 + RESET	Safety thermostat lockout
Er 03 + RESET	Other faults
Er 04 + 	Faulty primary circuit (no water or absence of flow)
Er 05 + 	Faulty fan control system
Er 06 + 	Faulty c.h. temperature probe NTC
Er 08 + 	Faulty external temperature probe NTC (if fitted)
Er 09 + 	Faulty flue temperature probe NTC
Er 10 + RESET	Lockout – flue temperature probe NTC (Flue temperature > 120 °C)
Er 14 + RESET	Faulty pump (absence of water flow in the main circuit) or primary temperature above 105 °C
Er 15 + RESET	None or too low water flow; Faulty pump (temp. difference between probes higher than 35° C)
Er 16 + RESET	Possible exchange of NTC probes (Flow or Return) or pump wrongly mounted (upside – down)
Er 17 + RESET	Faulty c.h. temperature probe NTC (Flow or Return)
Er 18 + RESET	Faulty primary circuit (no water or absence of flow)
L3	Useful output limitation (temperature difference between probes higher than 25° C) : Boiler test performing
Td	Thermostat Delayed : Boiler test performing
An 11	Parasite flame

5 Condensing heat exchanger

5.1 Function

The Condensing heat exchanger *A* in Fig. 5.1 has the function of transferring heat produced from combustion of the gas and from the flue exhausted gas to the water circulating in it.

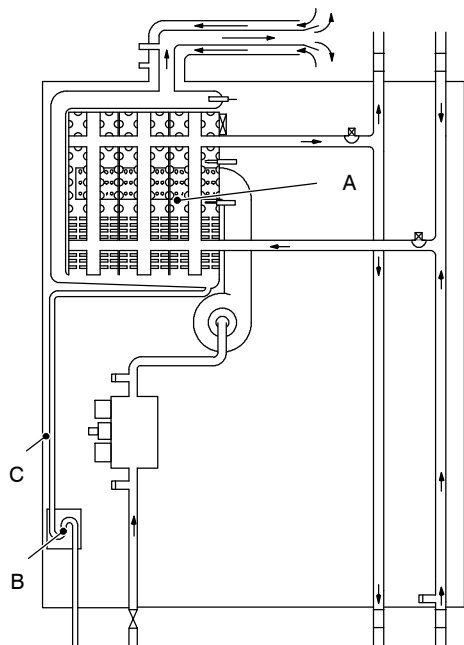

Fig. 5.1

By reducing the combustion products temperature, the latent heat of the vapour is transferred to the water circuit, allowing an extra gain of useful heat.

The condensed vapour is then drained through the condensate trap *B* and the draining pipe *C*.

5.2 Removal

Warning: isolate the boiler from the mains electricity supply before removing any covering or component.

- 1 Turn off the gas supply.
- 2 Remove all the case panels (see section 2).
- 3 Disconnect the flue system from the boiler.
- 4 Disconnect the air manifold *D* (Fig. 5.4) by pulling it.
- 5 Disconnect the rubber pipe *E* (Fig. 5.2).
- 6 Unscrew the gas connectors *F*.
- 7 Remove gas pipe *G*.
- 8 Unscrew the screws and remove the detection electrode connector *H*.
- 9 Unscrew the screws and remove the ignition electrodes connector *I*.
- 10 Unscrew the screw and remove the overheat thermostat *J*.
- 11 Disconnect the connector *K* by pressing the plastic hook placed on the side of the connector.
- 12 Disconnect the connector *L*

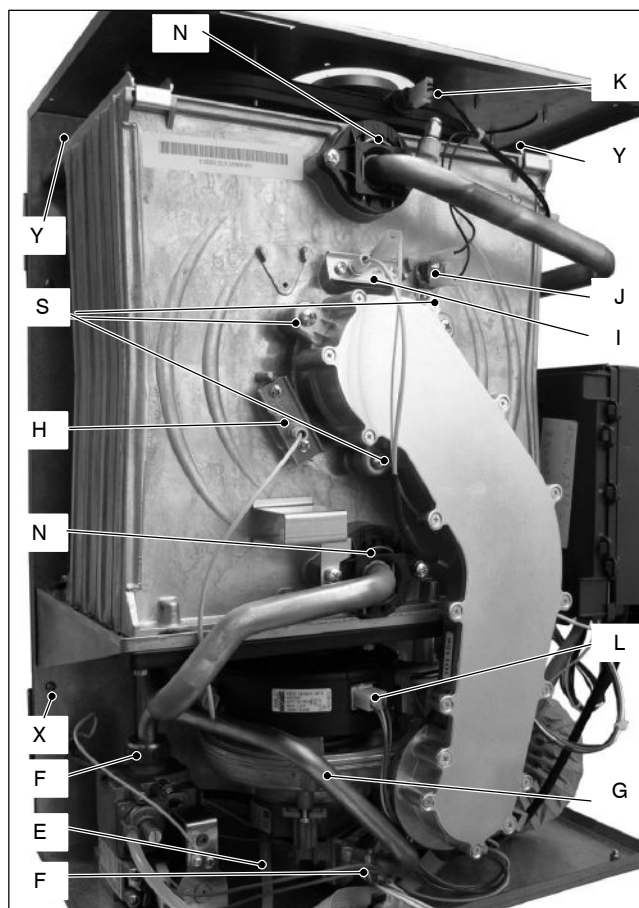

Fig. 5.2

- 13 Disconnect the fan connector *M* by pressing the plastic hook placed on the side of the connector (Fig. 5.4).

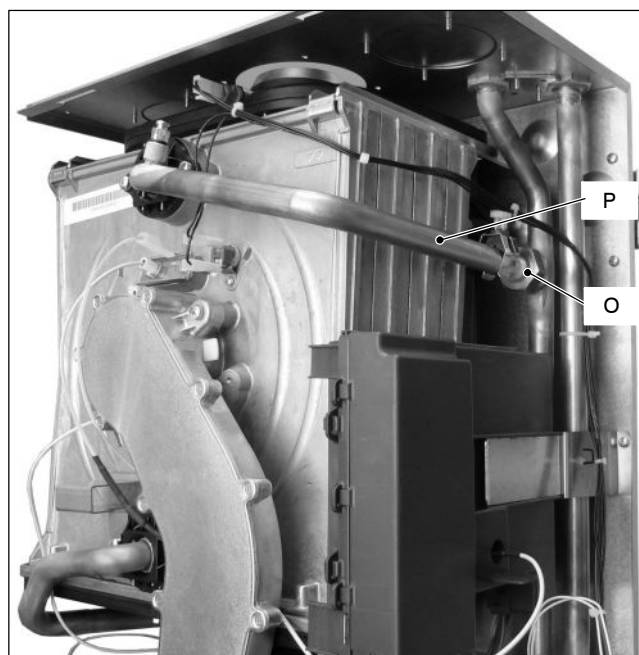

Fig. 5.3

- 14 Empty the primary circuit of the boiler.
- 15 Remove the forks *N* (Fig. 5.2).
- 16 Loosen the connection *O* and remove the pipe *P* (Fig. 5.3) from the Condensing heat exchanger.

- 17 Loosen the connection *Q* and remove the pipe *R* (Fig. 5.4) from the Condensing heat exchanger.
- 18 Unscrew the screws *S* .
- 19 Remove the fan – burner group.

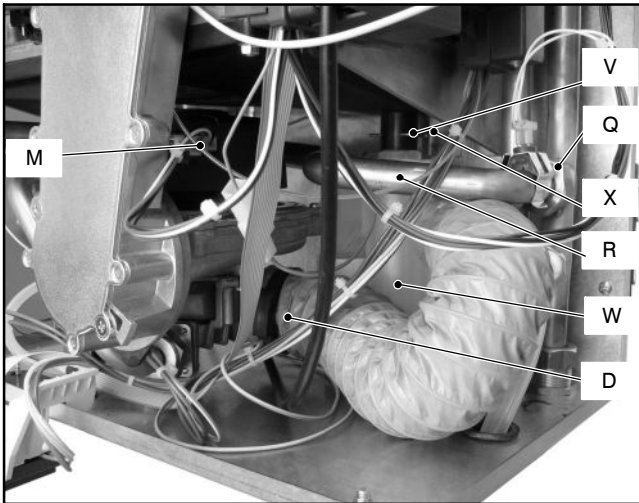

Fig. 5.4

- 20 Unscrew the screws *T* and remove the plate *U* (Fig. 5.5).
- 21 Remove the forks *V* and remove the condensate trap *W* moving it downwards (Fig. 5.4).

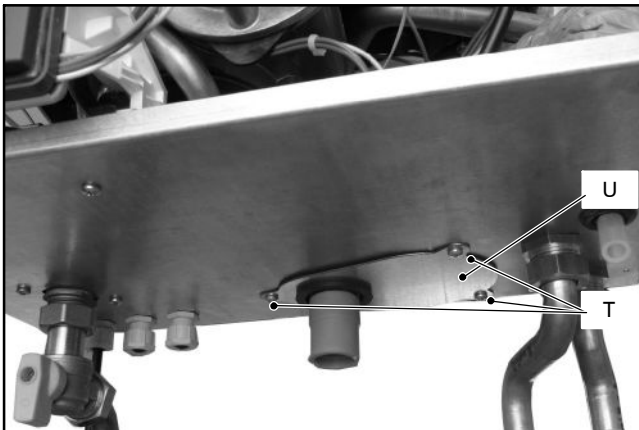

Fig. 5.5

- 22 Loosen the screws *X* (Fig. 5.4 – Fig. 5.2)
- 23 Unscrew the screws *Y* (Fig. 5.2).
- 24 Remove the Condensing heat exchanger slightly move it upwards, turn it frontwards freeing it from the below screws *X* (Fig. 5.4 – Fig. 5.2) and then extract it forwards.
- 25 Reassemble the Condensing heat exchanger carrying out the removal operations in reverse order.

Ensure to tighten the screws *S* – Fig. 5.2 firmly

5.3 Cleaning

If there are deposits of dirt between the fins of the Condensing heat exchanger, clean with a bristle paintbrush and remove the dust with a Hoover.

Warning: After cleaning or replacement as detailed above, it is deemed necessary to undertake a combustion analysis as detailed in chapter 8.3 section 11.

6 Main electronic control/ignition p.c.b.

6.1 Function

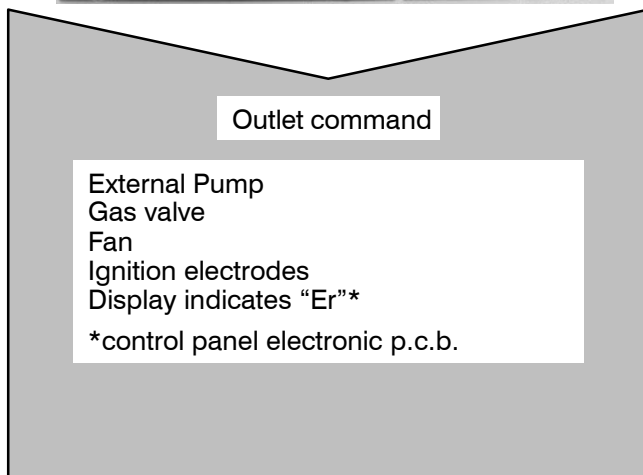
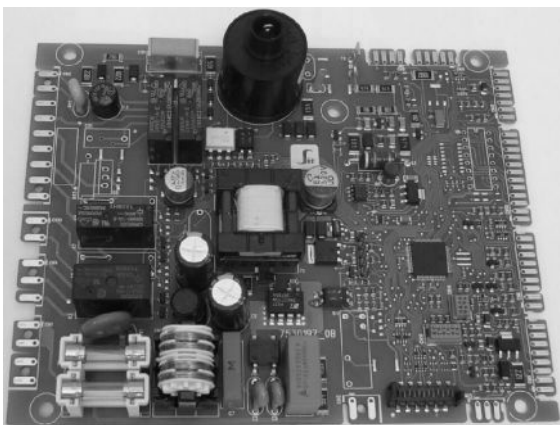
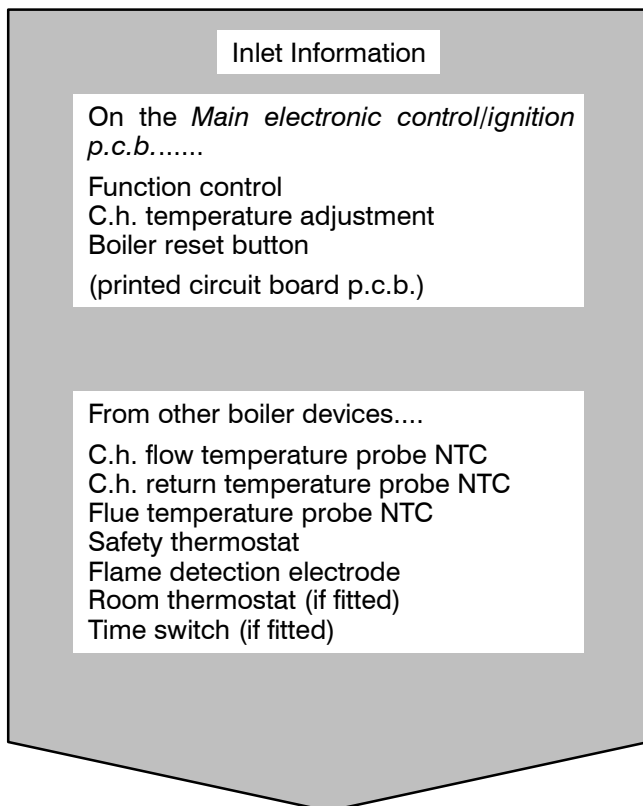

The fundamental function of the *Main electronic control/ignition p.c.b.* is that of controlling the boiler in relation to the external needs (i.e. heating the dwelling) and operating in order to keep the temperature of the hydraulic circuits constant.

This is obviously possible within the useful power and maximum working temperature limits foreseen.

Generally, the *Main electronic control/ignition p.c.b.* receives inlet information coming from the boiler (the sensors) or from the outside (printed circuit board p.c.b., room thermostat, etc.), processes it and consequently acts with outlet commands on other components of the boiler (Fig. 6.1).

The *Main electronic control/ignition p.c.b.* is also a full sequence ignition device and does a sequence of operations (ignition cycle) which lead to the ignition of the gas at the burner

It checks the presence of the flame during the entire period in which it is activated and supplies the fan regulating its speed.

The *Main electronic control/ignition p.c.b.* has a **safety function** and any incorrect interventions or tampering can result in conditions of dangerous functioning of the boiler.

The *Main electronic control/ignition p.c.b.* can lock the functioning of the boiler (lock state) and stop its functioning up to the resetting intervention. The lock – out is signalled on the display of the control panel electronic p.c.b. and can be reset only by using the boiler reset button placed on the printed circuit board p.c.b. (see section 7.1).

Some components which are connected to the device can activate the lock state. The causes of a lock state could be:

- The intervention of the safety thermostat (overheat of the primary circuit).
- The intervention of the flue temperature probe (overheat of the combustion products).
- A fault on gas supply.
- Faulty ignition (faulty ignition electrodes, their wiring or connection).
- Faulty flame detection (faulty detection electrode, its wiring or connection).
- Faulty condensate drainage.
- Faulty gas valve (faulty on–off operators or not electrically supplied).
- Faulty *Main electronic control/ignition p.c.b.*

Other components like the c.h. temperature probes NTC switch can temporarily stop the ignition of the burner but allow its ignition when the cause of the intervention has stopped.

NO TAG and Fig. 6.12 show the sequence of the operations that are carried out at the start of every ignition cycle and during normal functioning.

6.2 Selection and adjustment devices

On the *Main electronic control/ignition p.c.b.* several selection, adjustment and protection devices are located. (Fig. 6.2).

Fig. 6.1

Some of these devices are directly accessible by the user (function control, temperature adjustment etc.) others, like the fuses, are accessible by removing the main electronic p.c.b. lid.

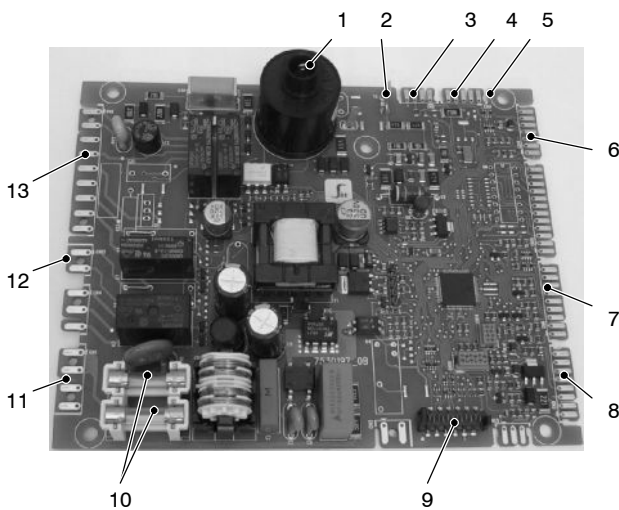

Fig. 6.2

- 1 Connector – ignition electrode.
- 2 Connector – flame detection electrode.
- 3 Connector – controller fan.
- 4 Connector – c.h. return temperature probe NTC
- 5 Connector – flue temperature probe NTC.
- 6 Connector – external temperature probe (optional).
- 7 Connector – safety thermostat and c.h. flow temperature probe NTC.
- 8 Connector – remote control (optional).
- 9 Connector – display and function control / c.h. temperature adjustment control panel p.c.b.
- 10 Fuse F1, F2 2A F
- 11 Connector – electric supply *Main electronic control/ignition p.c.b.*
- 12 Connector – electric supply control panel p.c.b.
- 13 Connector – gas valve, external pump and fan.

6.3 Checking the temperature

The *Main electronic control/ignition p.c.b.* makes it possible adjust the c.h. water flow temperature.

The temperature of the water is converted into an electric signal by means of temperature probes. The user, setting the desired temperature with the control panel p.c.b. key .

If the power requested is lower than 40% of the maximum power output then control is achieved by switching ON the burner at minimum power, then switching OFF (ON/OFF function). If the power requested is higher, then the burner is switched ON at maximum power and will control by modulating to 40% of the maximum power output.

During the c.h. operation (Fig. 6.3), the signal coming from the c.h. temperature probe is compared to the signal given by the control panel p.c.b. through the adjustment made by the user (key). The result of such a comparison operates the fan speed thus regulating the gas flow rate and consequently changing the useful output of the boiler.

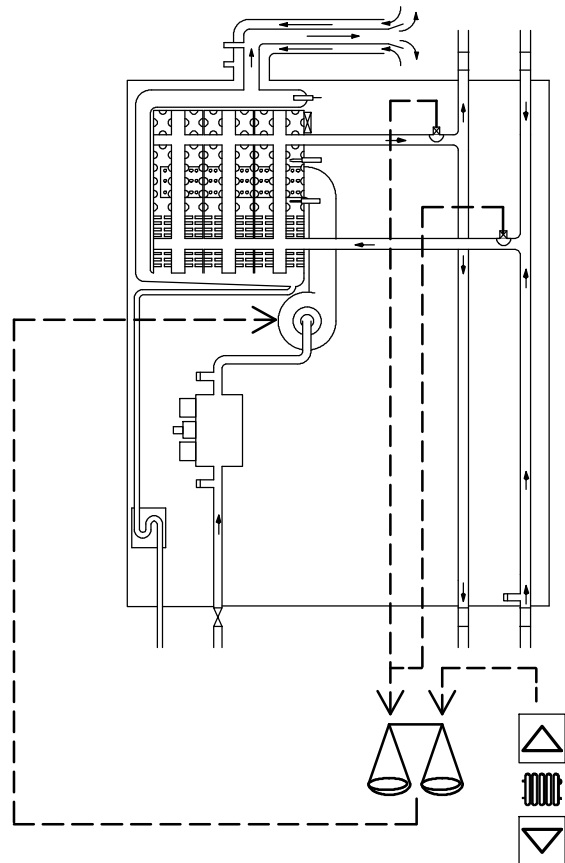

Fig. 6.3

The control sequences in c.h. function are illustrated in detail in section 6.7.

6.4 Setting the boiler control function modes

It is possible to select the various boiler control function modes hereafter named “parameters” by using the keys of the control panel p.c.b.

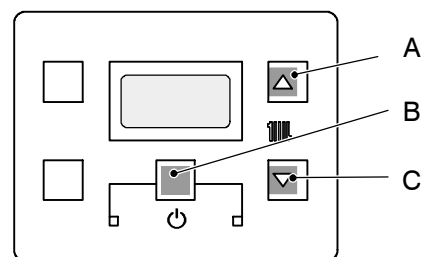

Fig. 6.4

- 1 To enter in the parameters setting mode press contemporary the 3 keys (A – B – C Fig. 6.4) for 10 second until the display shows Fig. 6.5

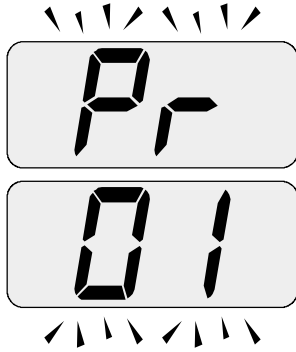

Fig. 6.5

- 2 To move through the parameters press c.h. set keys (A or C Fig. 6.6)

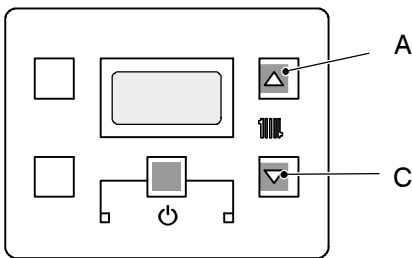

Fig. 6.6

- 3 The display shows Fig. 6.7

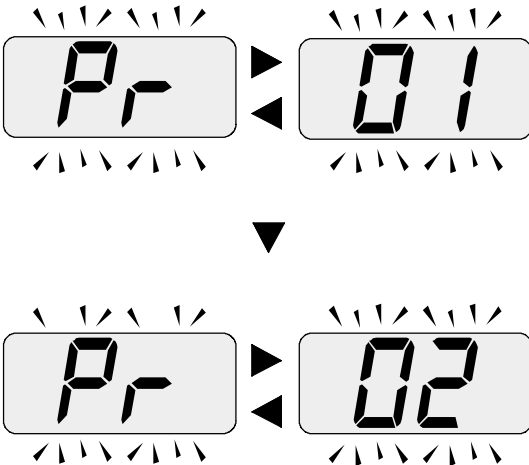

Fig. 6.7

- 4 To modify the parameter press contemporary the keys (A – B Fig. 6.8)

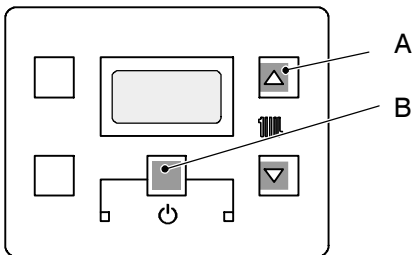

Fig. 6.8

- 5 To change the parameters press c.h. set keys (A or C Fig. 6.6)
6 To memorize the setting press the key (B Fig. 6.9)

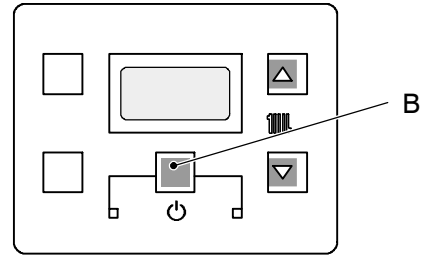

Fig. 6.9

- 7 To exit for setting without modifying the set press the keys (B – C Fig. 6.10)

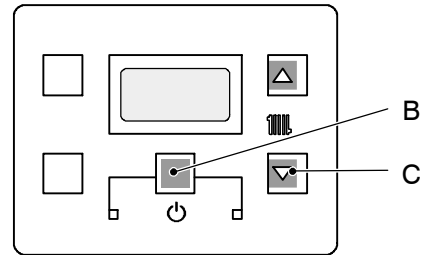

Fig. 6.10

To reset the boiler to the normal operation press contemporary the 3 keys (A – B – C Fig. 6.4) for 10 second.

The following table gives details of each parameter and the possible value that can be set.

Important: at the end of the setting operation it is important to fill/update the table in the installation manual see chapter COMMISSIONING section: Setting record.

PARAMETER	DIGIT	VALUES
Boiler type (to be updated with the complete range)	Pr 01	00 = No power Er 99 18 = Activ A 12OV 19 = Activ A 15OV 20 = Activ A 20OV 21 = Activ A 25OV
Not used	Pr 02	
Not used	Pr 03	
Not used	Pr 04	
Gas type	Pr 05	00 = G20 Natural 05 = G31 Propane
Not used	Pr 06	
C.h. flow max temperature °C	Pr 07	85 ÷ 45 (factory set 85 °C)
Factory parameters reset	Pr 08	00 = No reset 04 = All parameters return to factory set with the exclusion of Pr 01 and Pr 05 39 = All parameters return to factory set included Pr 01 and Pr 05

PARAMETER	DIGIT	VALUES
Chimney sweep function	Pr 09	00 = No chimney sweep fun (factory set) 01 = Low power sweep-test 04 = C.h. power sweep-test 07 = D.h.w. power sweep-test
C.h. reignition frequency	Pr 10	00 ÷ 99 (0 ÷ 600 sec.) (factory set 30 = 3 minutes)
C.h. pump post-circulation	Pr 11	00 ÷ 99 (0 ÷ 600 sec.) (factory set 10 = 1 minute)
Max. useful output in c.h. mode	Pr 12	00 ÷ 99 (0 ÷ 100%) factory set: 99 = Activ A 12OV 99 = Activ A 15OV 99 = Activ A 20OV 99 = Activ A 25OV
C.h. pump working type	Pr 13	00 = Depends on room thermostat (factory set) 04 = Always running
Ignition power	Pr 14	00 ÷ 99 (0 ÷ 100%) factory set: Natural gas (G20) 30 = Activ A 12OV 30 = Activ A 15OV 30 = Activ A 20OV 40 = Activ A 25OV Propane (G31) 40 = Activ A 12OV 40 = Activ A 15OV 40 = Activ A 20OV 40 = Activ A 25OV
K value (external probe diagram)	Pr 15	01 (=0,1) ÷ 60 (=6,0) K value factory set: 00 = Off
Not used	Pr 16	
D.h.w. burner turn off function	Pr 17	00 = Burner off at fixed d.h.w. = 65 °C (factory set) 01 = Burner off at set point +5 °C
NTC on the c.h. return	Pr 18	00 = Probe not present (factory set) 01 = Probe present

PARAMETER	DIGIT	VALUES
Not used	Pr 19	
Not used	Pr 20	
Not used	Pr 21	
Not used	Pr 22	
Not used	Pr 23	
Not used	Pr 24	
Not used	Pr 25	
Not used	Pr 26	
C.h. minimum set-point	Pr 27	25 ÷ 45 (factory set 25 °C)

Tab. 6.1

6.5 Checks

✓ Check that the fuses are complete

If the *Main electronic control/ignition p.c.b.* does not supply any device (pump, fan, etc.) check that the fuses 10 (Fig. 6.2) are complete.

If a fuse has blown replace it with one that has the same characteristics after having identified the reason for failure.

✓ Lock sequence

Start the boiler until the burner is ignited.

With the burner firing, interrupt the gas supply. The *Main electronic control/ignition p.c.b.* must carry out four complete ignition cycles and then, after about 4 minutes, goes to lock-out state.

Switch off and on the electricity supply to the boiler, by means of the fused spur isolation switch, the device must not unlock and the burner must not turn on

6.6 Removal of the electronic control p.c.b

⚠ **Warning: isolate the boiler from the mains electricity supply before removing any covering or component.**

When replacing the *Main electronic control/ignition p.c.b.* all parameters must be correctly checked / adjusted accordingly with the values noted in table in the installation manual see chapter COMMISSIONING section: Setting record (for information on parameters see also section 6.4).

- 1 Remove all the body panels (see section 2.2).
- 2 Gain access to the parts located inside the Main electronic p.c.b. box as explained in the section 2.4 of this manual.
- 3 Remove all the wiring connected to the *Main electronic control/ignition p.c.b.*

Main electronic control/ignition p.c.b.

- 4 Delicately flex the hooks *D* in the directions indicated (Fig. 6.11) in order to release the circuit from the box.
- 5 Remove the *Main electronic control/ignition p.c.b.*

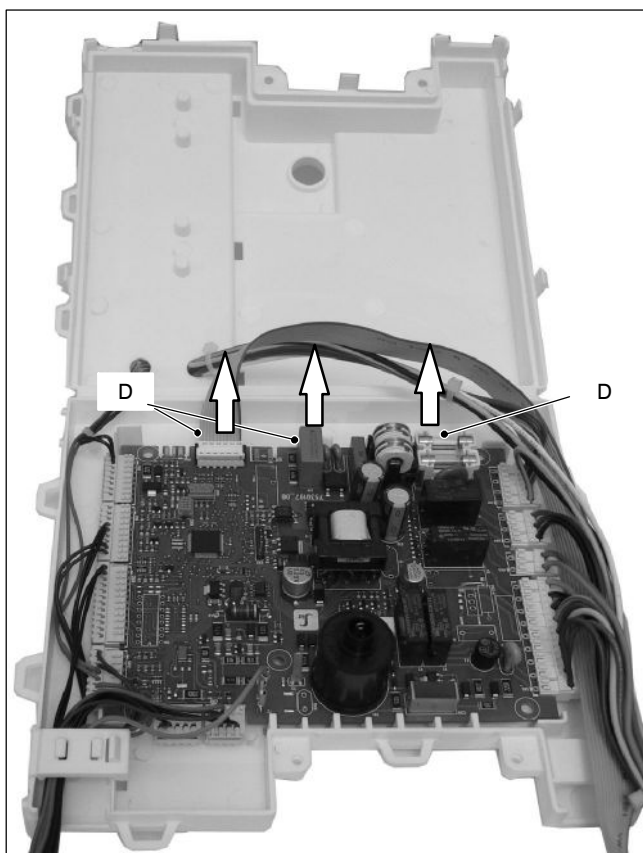

Fig. 6.11

- 6 Re-assemble the *Main electronic control/ignition p.c.b.* following the removal procedures in the reverse order.

Important

When re-assembling the *Main electronic control/ignition p.c.b.*:

- 7 It is not necessary to utilise static protections but it is advisable to ensure that the pcb is handled with care and held at the edges and with clean dry hands.

Attention

After installing the *Main electronic control/ignition p.c.b.* properly set the parameters.

 **Warning: After cleaning or replacement as detailed above, it is deemed necessary to undertake a combustion analysis as detailed in chapter 8.3 section 11.**

6.7 Thermal control in the "c.h." mode

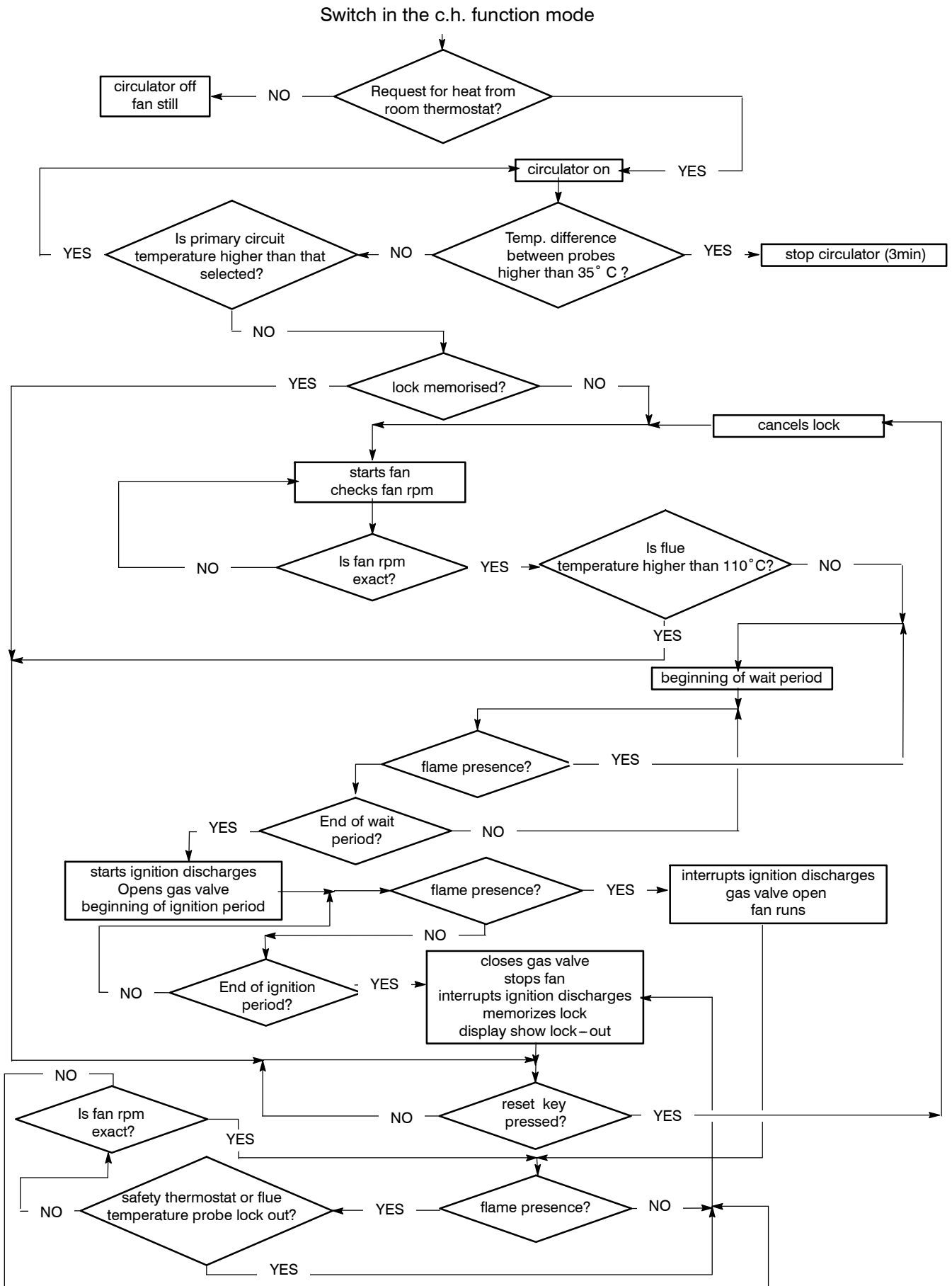

Fig. 6.12

7 Control panel electronic p.c.b.

7.1 Function

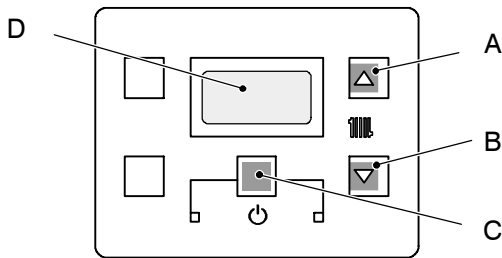

Fig. 7.1

A) C.h. temperature increase key

B) C.h. temperature reduce key

C) Reset/Stand-by/Winter/Summer key

D) Display

The Control panel electronic p.c.b. can give to the service 3 levels of informations:

- Normally information
- Info modality
- Function modes setting modality

7.2 Normally information

KEY

RESET	The symbol indicates that the boiler can be directly reactivated by the user, by pressing the reset button.
	The symbol indicates that the fault requires intervention on behalf of specialised technical assistance.
	All symbols represented with lines that surround them, indicate that the symbol is flashing.

SIGNAL DISPLAYED BY THE LCD

LCD	FUNCTION
Er 01 + RESET	Lack of burner ignition on safety lockout
Er 02 + RESET	Safety thermostat intervention lockout
Er 03 + RESET	General lockout
Er 10 + RESET	Flue probe interven lockout
Er 14 + RESET	Faulty pump or primary temperature above 105° C
Er 15 + RESET	None or too low water flow; Faulty pump (temp. difference between probes higher than 35° C)
Er 16 + RESET	Possible exchange of NTC probes (Flow or Return) or pump wrongly mounted (upside – down)

LCD	FUNCTION
Er 17 + RESET	Faulty c.h. temp. probe NTC (Flow or Return)
Er 18 + RESET	Faulty primary circuit (no water or absence of flow)
Er 04 +	Faulty primary circuit (no water or absence of flow)
Er 05 +	Faulty fan control system
Er 06 +	Faulty c.h. temp. probe NTC
Er 08 +	Faulty external temp. probe NTC
Er 09 +	Faulty flue temp. probe NTC
00	Boiler Stand-By (anti-freeze protection activated)
30 °C	Boiler waiting for heat request.
32 °C	Boiler in winter mode. The primary circuit temperature is displayed.
34 °C	Boiler on demand for c.h. power.
	Burner ignition (spark)
0	Flame present (Burner on)
bP °C	Boiler in anti-freeze phase (bP flashing + temperature flashing)
15	
AF °C	Boiler in antifrost phase (AF flashing + temperature flashing)
16	
78	Set c.h. (all other symbols are disabled)
Po	Pump activated for the post-circulation phase (Po flashing + temperature flashing)
35	

LCD	FUNCTION
uu 56	Delayed burner ignition for setting the system (uu flashing + temperature flashing)
65	Boiler in chimney sweep functioning mode. The chimney sweep is activated by setting "parameter 09=01" and is visualised by the switching on of the hand and alternate flashing between the temperature and the communication and radiator symbol.
td	Thermostat Delayed: Boiler test performing.
L3	Useful output limitation (temp. difference between probes higher than 25°C): Boiler test performing.
An 11	Flame detection error (An flashing + error flashing number)

7.3 Info modality

The INFO mode allows the display of some information on the boiler functioning status. In case of malfunctioning of the boiler, it may be useful to communicate such information to the Authorised Service Centre Engineer so that the causes can be understood.

In order to access the INFO mode, press keys A and C (Fig. 7.1) at the same time until the letter **di** appears on the display that alternates with a code (Fig. 7.2).

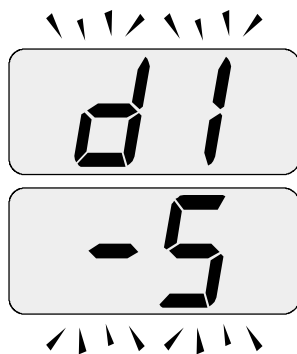

Fig. 7.2

To scroll the values press B (reduce) and A (increase) keys (Fig. 7.1). In order to exit the INFO mode, hold keys A and C (Fig. 7.1) pressed at the same time.

The following table gives details of each parameter and the possible value that can be show.

Description	Parameter	Value
External temperature °C (if fitted)	d1	-5
K value (external probe diagram) (the value is x 10)	d2	12
Offset (Transaltion of K diagram ± 15°C)	d3	-10
C.h. temperature °C (calculated by external sensor)	d4	66
C.h. flow temperature °C	d5	78
C.h. return temperature °C	d6	44
Flue temperature °C	d8	67
Fan speedy (the value has to be x 100 = 4400 rpm)	d9	44
SW version BC (burner control)	dc	01
SW version MB (main board)	dd	03

Tab. 7.1

7.4 Function modes setting modality

It is possible to select the various boiler control function modes hereafter named "parameters" by using the keys of the control panel p.c.b.

During the function modes setting, the boiler does not operate.

To get in function modes setting modality see section 6.4

7.5 Removal of the control panel electronic p.c.b

Warning: isolate the boiler from the mains electricity supply before removing any covering or component.

- 1 Remove all the body panels (see section 2.2).
- 2 Gain access to the parts located inside the *Control panel electronic p.c.b.* as explained in the section 2.3 of this manual.
- 3 Remove all the wiring *A* connected to the *Control panel electronic p.c.b.* (Fig. 7.3).

Control panel electronic p.c.b.

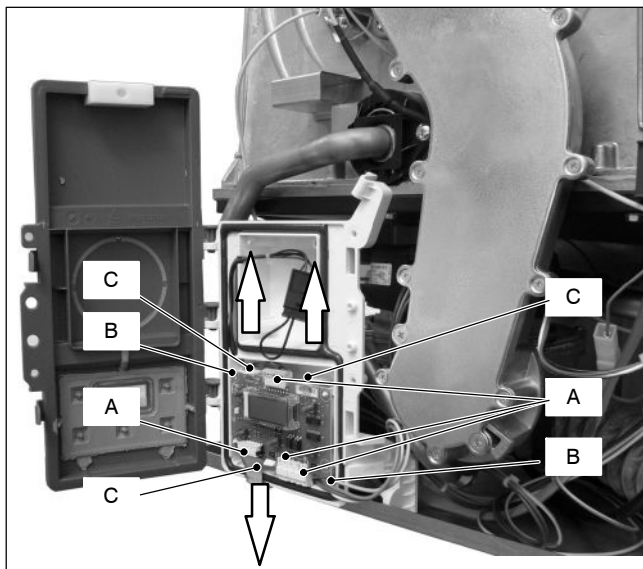

Fig. 7.3

- 4 Unscrew the screws *B*
- 5 Delicately flex the hooks *C* in the directions indicated (Fig. 7.3) in order to release the circuit from the box.
- 6 Remove the *Control panel electronic p.c.b.*
- 7 Reassemble the *Control panel electronic p.c.b.* carrying out the removal operations in the reverse order.

8 Gas valve

8.1 Function

The Gas valve A in Fig. 8.1 controls the gas inflow to the boiler burner.

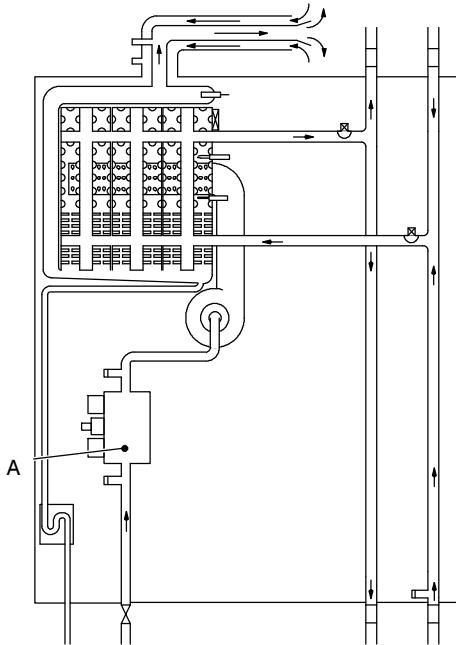

Fig. 8.1

By means of an electric command given to the on–off operators the passage of the gas through the Gas valve can be opened or closed.

8.2 Description of the parts (Fig. 8.2)

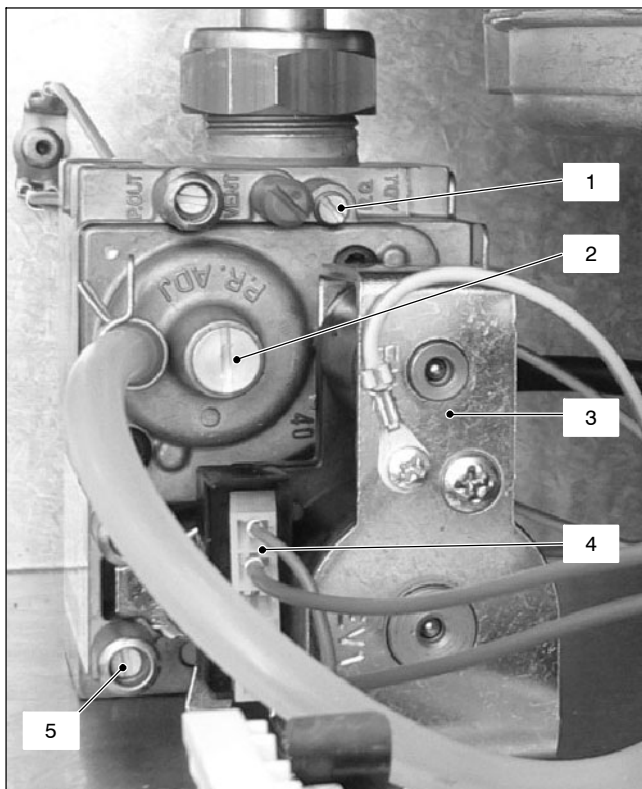

Fig. 8.2

- 1 Maximum gas pressure adjustment
- 2 Minimum gas pressure adjustment
- 3 On–off operators
- 4 On–off operators electric connector
- 5 Gas valve inlet pressure test point

8.3 Adjustment

Warning: isolate the boiler from the mains electricity supply before removing any covering or component.

Check the supply pressure before making any adjustment to the gas valve.

- 1 Close the gas inlet valve.
- 2 Remove the front panel of the case and lower the control panel (see sections 2.2 and 2.3).
- 3 Loosen the internal screw on the Inlet Pressure Test Point 5 (Fig. 8.2) of the Gas valve and connect a pressure gauge using a suitable hose.
- 4 Open the gas inlet valve.
- 5 Turn on the electricity supply to the boiler, switching on the fused spur isolation switch.
- 6 Set the boiler in c.h. function as illustrated in Fig. 8.3

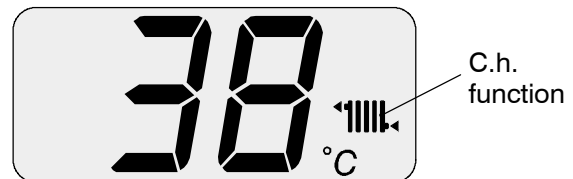

Fig. 8.3

- 7 Make sure that the room thermostat is in the “heat request” position.
- 8 Read the inlet pressure value and ensure that it is within the limits given in the table *Gas supply pressures*, of the user/installation manual. If it does not comply with the required pressure check the gas supply line and governor for faults and/or correct adjustment.
- 9 Switch off the boiler **close the gas inlet valve**.
- 10 Disconnect the pressure gauge and close the Inlet Pressure Test Point 5 (Fig. 8.2).

Gas valve adjustment

⚠ The person carrying out a combustion measurement should have been assessed as competent in the use of a flue gas analyser and the interpretation of the results. The flue gas analyser used should be one meeting the requirements of BS7927 or BS–EN50379–3 and be calibrated in accordance with the analyser manufacturers’ requirements, and have a current calibration certificate.

- 11 Fit the probe of the flue analyser in the flue exhaust sampling point located on the exhaust pipes of the boiler (Fig. 8.4).

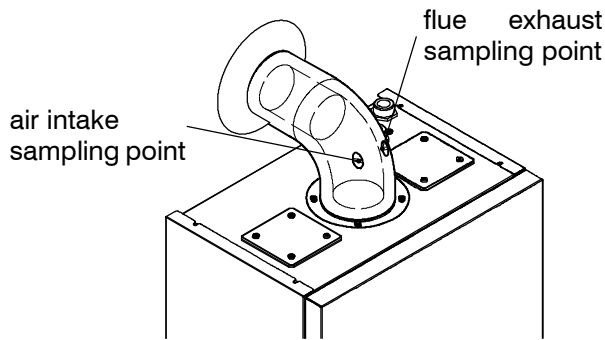

Fig. 8.4

- 12 Turn on the boiler, switching on the fused spur isolation switch.
- 13 Open the gas inlet valve.
- 14 Turn on the boiler and operate for 2 minutes to pre-heat the flue, before commencing any adjustments

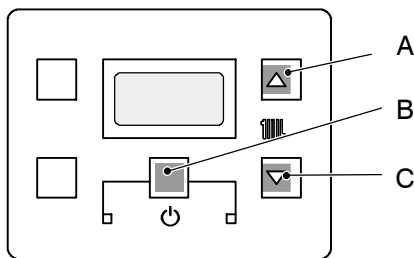

Fig. 8.5

- 15 To enter in the parameters setting mode press contemporary the 3 keys (A – B – C Fig. 8.5) for 10 second until the display shows Fig. 8.6

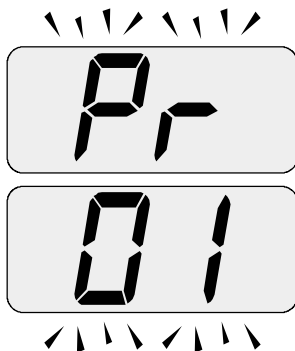

Fig. 8.6

Adjusting minimum gas valve setting

- 16 Press keys A and C (Fig. 8.5) at the same time until the display shows the letters **LP** that alternate with the heating water temperature value (e.g. **45**), indicating the activation of the "chimney sweep function" at minimum output (Fig. 8.7).

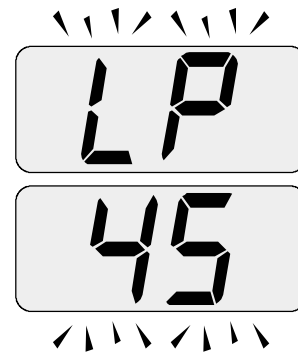

Fig. 8.7

- 17 Make sure that the room thermostat is in the "heat request" position.
- 18 Allow the analyser to give a stable reading.
- 19 Read the CO₂ % value. It should be between:

Model	Type gas	CO ₂ % value (range)
Activ A 120V Activ A 150V	Natural (G20)	8,2 – 9,0
	Propane (G31)	9,2 – 10,2
Activ A 200V Activ A 250V	Natural (G20)	8,2 – 9,2
	Propane (G31)	9,2 – 10,2

Tab. 8.1

To adjust the CO₂ % value remove the brass plug by unscrewing it and rotate the Allen key screw \varnothing 4 mm (2 – Fig. 8.2) (by rotating it clockwise the CO₂ % increases).

Checking the maximum gas valve setting

- 20 Press key A to vary the output in chimney sweep mode: when the display shows the letters **CP** that alternate with the heating water temperature value (e.g. **60**), the "chimney sweep function" is at maximum output in heating mode (Fig. 8.8);

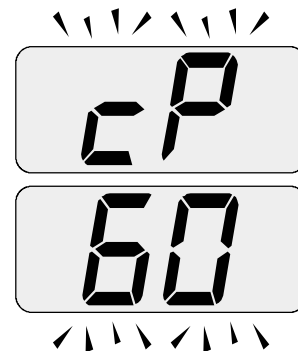

Fig. 8.8

- 21 Press further key A. The display shows the letters **dP** that alternate with the heating water temperature value (e.g. **60**) (Fig. 8.9). On this models this step is not relevant and the value shown is the same of the step 20. No setting is needed on this step.



Fig. 8.9

- 22 Allow the analyser to give a stable reading.
- 23 Read the CO₂ % value.
It should be between:

Model	Type gas	CO ₂ % value (range)
Activ A 12OV Activ A 15OV Activ A 20OV Activ A 25OV	Natural (G20)	8,9 – 9,8
	Propane (G31)	9,9 – 10,8

Tab. 8.2

To adjust the CO₂ % value rotate screw (1 – Fig. 8.2) (by rotating it clockwise the CO₂ % decreases).

- 24 Press keys A – B – C (Fig. 8.5) at the same time again to exit the "chimney sweep mode" and return to the previously set boiler status (Fig. 8.10)



Fig. 8.10

- 25 Switch off the boiler and turn off the room thermostat.
- 26 Close the air-flue sampling points.
- 27 After adjustment fit the protective brass plug (2, Fig. 8.2).

Important: after the gas pressure checks and any adjustment operations, all of the test points must be sealed.

8.4 Checks

Warning: isolate the boiler from the mains electricity supply before removing any covering or component.

- ✓ Check the on-off operators coils
- 1 Remove the front panel of the case.
- 2 Disconnect the electrical connector 4 (Fig. 8.2).
- 3 Measure the electrical resistance between the connector pins of the on-off operators as illustrated in Fig. 8.11.

ON–OFF Operator
approx. 6 400 Ω*

ON–OFF Operator
approx. 920 Ω*

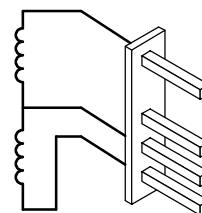

* at ambient temperature.

Fig. 8.11

8.5 Removal of the gas valve

Warning: isolate the boiler from the mains electricity supply before removing any covering or component.

- 1 Remove the front panel of the case as explained in the section 2.3 of this manual.
- 2 Disconnect the connector *D* (Fig. 8.12).
- 3 Unscrew the screws *E* and disconnect the earth connector *F*.

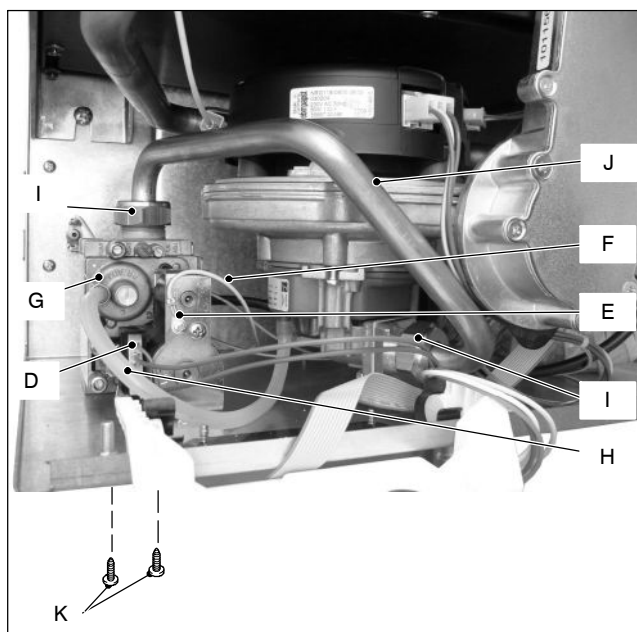

Fig. 8.12

- 4 Turn off the gas supply and disconnect the gas isolation cock connector from the inlet port of the gas valve.
- 5 Using pliers, remove the spring *G* and the rubber pipe *H* (Fig. 8.12).
- 6 Unscrew the connectors *I* (Fig. 8.12) and remove the pipe *J*.
- 7 Unscrew the screws *K* and remove the valve (Fig. 8.12).
- 8 Reassemble the valve carrying out the removal operations in reverse order.

Before fitting a new valve, it is advisable to pre-set it as follows.

- 9 Remove the brass plug and turn the plastic screw inside it fully clockwise until it stops. Do not over-tight.
- 10 Turn it counter-clockwise 2 and 3/4 turns.

- 11 Adjust the gas valve using the flue analyser as described in section 8.3.

After any service operation on the components of the gas circuit check all the connections for gas leaks.



Warning: After cleaning or replacement as detailed above, it is deemed necessary to undertake a combustion analysis as detailed in chapter 8.3 section 11.

9 Temperature probe

9.1 Function

The Temperature probe has the function of converting the temperature of the water in the hydraulic circuit where it is installed into an electrical signal (resistance).

The relation between temperature and electrical resistance is stated in Fig. 9.1.

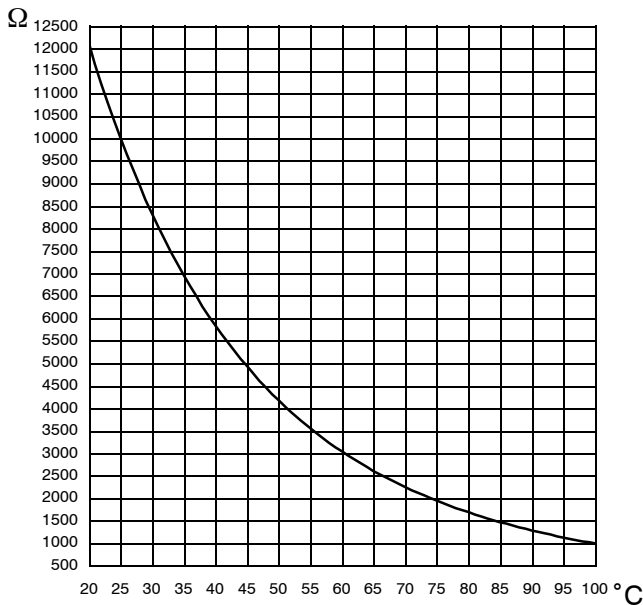

Fig. 9.1

On the boiler there are two Temperature probes. One on the output of the primary condensing heat exchanger (c.h. flow Temperature probe) *A* in Fig. 9.2 and Fig. 9.3; one on the input of the primary condensing heat exchanger (c.h. return Temperature probe) *B* in Fig. 9.2 and Fig. 9.4.

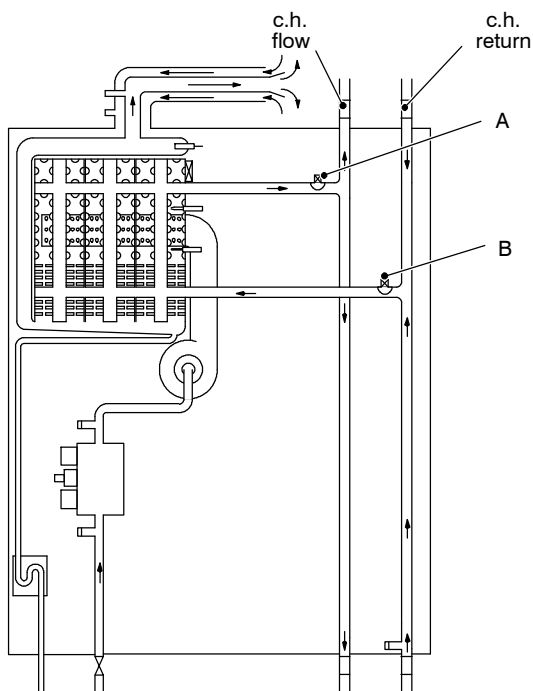

Fig. 9.2

9.2 Checks

- ✓ Temperature–resistance relationship
- ⚡ **Warning: isolate the boiler from the mains electricity supply before removing any covering or component.**

Disconnect the cable from the Temperature probe.

Measure the temperature of the pipe *C* (c.h. flow Temperature probe) (Fig. 9.3) or of the pipe *D* (c.h. return Temperature probe) (Fig. 9.4) where the Temperature probe is located and check the electrical resistance according to the graph in Fig. 9.1.

9.3 Removal of the c.h. flow Temperature probe

- ⚡ **Warning: isolate the boiler from the mains electricity supply before removing any covering or component.**

- 1 Remove all the case panels.
- 2 Remove the electric connector *E* and remove the c.h. Temperature probe *A* – Fig. 9.3
- 3 Reassemble the c.h. flow Temperature probe carrying out the removal operations in reverse order.



Fig. 9.3

9.4 Removal of the c.h. return Temperature probe

- ⚡ **Warning: isolate the boiler from the mains electricity supply before removing any covering or component.**

- 1 Remove all the case panels.
- 2 Remove the electric connector *F* and c.h. return Temperature probe *B* – Fig. 9.4
- 3 Reassemble the c.h. return Temperature probe carrying out the removal operations in reverse order.

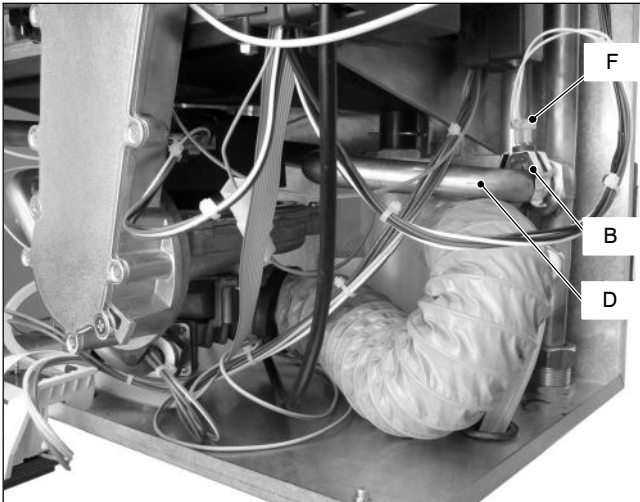

Fig. 9.4

10 Fan and Air box

10.1 Function

The function of the Fan *A* (Fig. 10.1) is to force the mixture of air and gas into the burner.

The function of the Air box *B* is to mix the gas and the air in the right proportion.

The flow rate of the air–gas mixture and consequently the input power of the boiler is proportional to the speed of the fan that is controlled by the electronic control p.c.b.

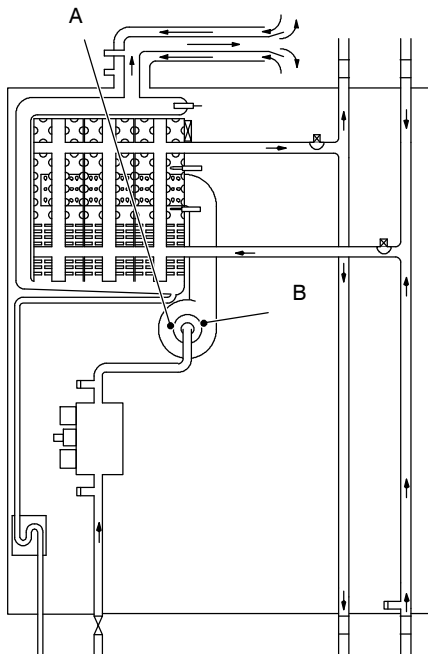

Fig. 10.1

10.2 Removal of the Fan and the Air box

Warning: isolate the boiler from the mains electricity supply before removing any covering or component.

- 1 Turn off the gas supply.
- 2 Remove all the case panels (see section 2).

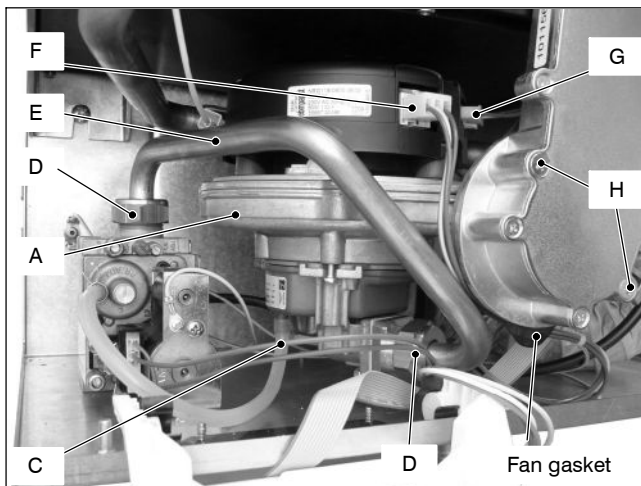

Fig. 10.2

- 3 Disconnect the rubber pipe *C* (Fig. 10.2).
- 4 Unscrew the gas connectors *D* and remove the gas pipe *E*.
- 5 Disconnect the connector *F*
- 6 Disconnect the fan connector *G* by pressing the plastic hook placed on the side of the connector.
- 7 Unscrew the screws *H*.
- 8 Remove the fan *A* with the air box *B*.
- 9 Remove the screws *I* and the air box *B* (Fig. 10.3).

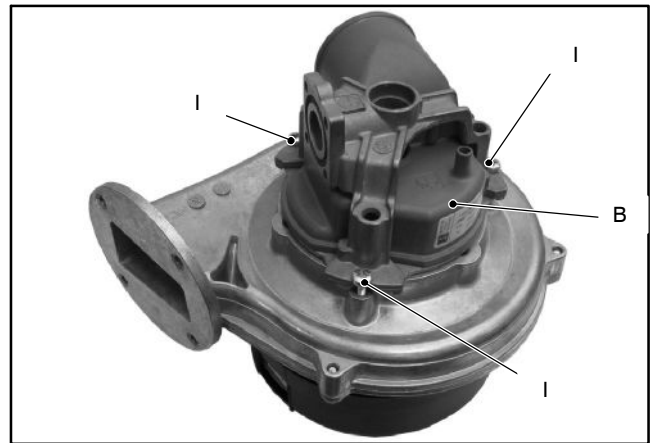

Fig. 10.3

- 10 Open the strip *J* by sliding the edges with the help of a screwdriver and remove the Air box (Fig. 10.4).

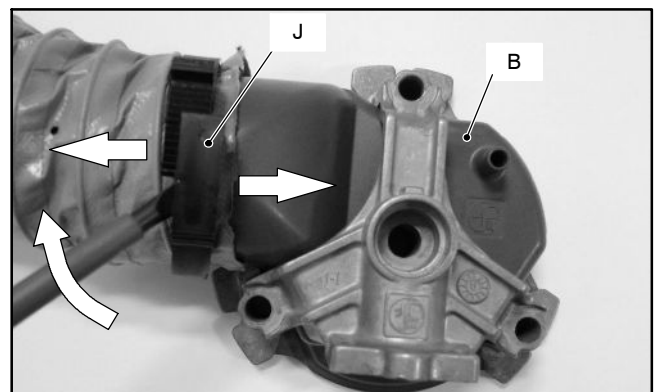

Fig. 10.4

- 11 Assemble the Fan and the Air box carrying out the removal operations in reverse sequence.

Before reassembling ensure the fan gasket (Fig. 10.2) is correctly mounted.

After any service operation on the components of the gas circuit check all the connections for gas leaks.

Warning: After cleaning or replacement as detailed above, it is deemed necessary to undertake a combustion analysis as detailed in chapter 8.3 section 11.

11 Ignition and detection electrodes and burner

11.1 Function

Three electrodes are fitted on the fan–burner group. Two of them, fitted on the right side of the fan–burner group *A*, are the ignition electrodes *B*

On the left side is the detection electrode *C* and it detects the presence of the flame.

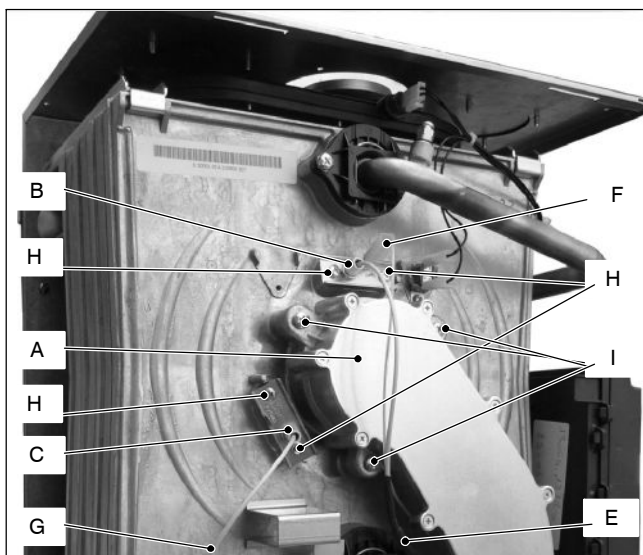

Fig. 11.1

The burner *D* is fitted on the rear of the fan–burner group *A*.

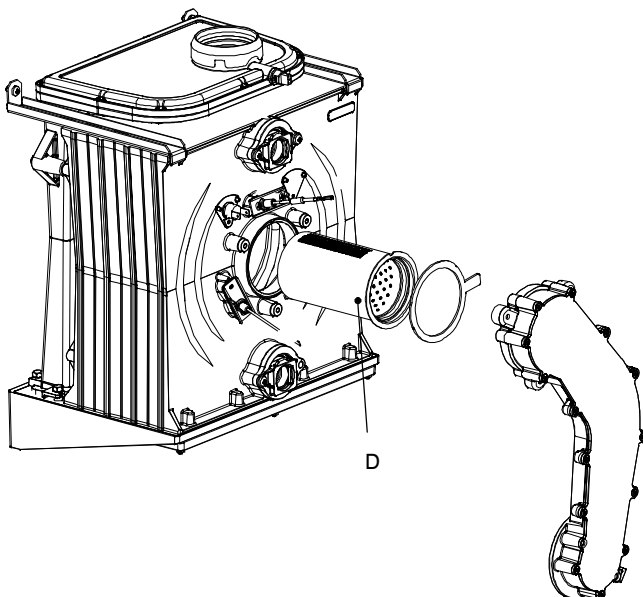

Fig. 11.2

11.2 Removal of the Ignition and detection electrodes

Warning: isolate the boiler from the mains electricity supply before removing any covering or component.

- 1 Remove all the case panels (see section 2) .

- 2 Disconnect the ignition electrodes connector *E* and the earth wire *F* (Fig. 11.1) and disconnect the detection electrode connector *G*.
- 3 Unscrew the screws *H* and remove the ignition electrodes *B* and the detection electrode *C* (Fig. 11.1).
- 4 Assemble the Ignition and detection electrodes carrying out the removal operation in reverse order.

11.3 Removal of the burner

Warning: isolate the boiler from the mains electricity supply before removing any covering or component.

- 1 Remove the air box and the fan (see section 10.2)
- 2 Unscrew the screws *I* (Fig. 11.1) and remove the fan–burner duct *A*.
- 3 Remove the burner by sliding it forward.

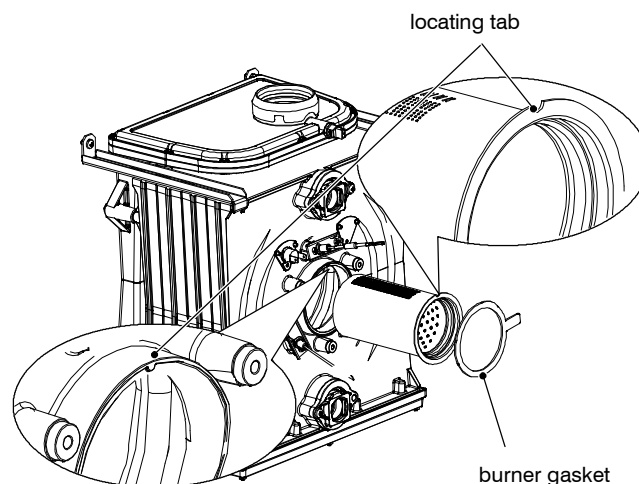

Fig. 11.3

- 4 Assemble the burner carrying out the removal operation in reverse order. Ensure the burner is correctly located by lining up the locating tab (Fig. 11.3).

Before reassembling ensure the burner gasket is correctly located.

Warning: After cleaning or replacement as detailed above, it is deemed necessary to undertake a combustion analysis as detailed in chapter 8.3 section 11.

11.4 Checks

- ✓ Check the position of the electrode edges

Warning: isolate the boiler from the mains electricity supply before removing any covering or component.

- 1 Remove the ignition electrodes (see section 11.2)
- 2 Check for the correct distance between the metallic edges of the ignition electrode (see Fig. 11.4).

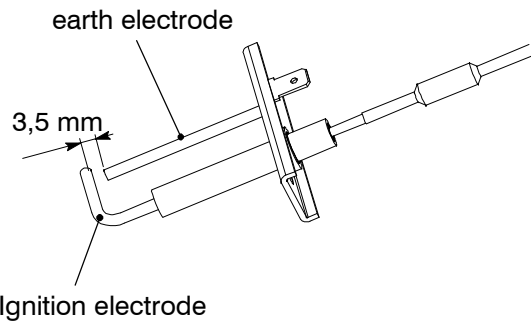

✓ Check the connection wires.

Fig. 11.4

12 Safety thermostat

12.1 Function

The safety thermostat *A* in Fig. 12.1 is a device that senses the temperature of the primary circuit water which flows in the outlet pipe of the condensing heat exchanger.

If the temperature control system of the boiler fails and the temperature of the primary circuit reaches a dangerous temperature, the safety thermostat opens the electric circuit that supplies the on-off operators of the gas valve.

Consequently, the full sequence ignition device attempts to light the burner and, at the end, locks the boiler and lights the lock-out on the display.

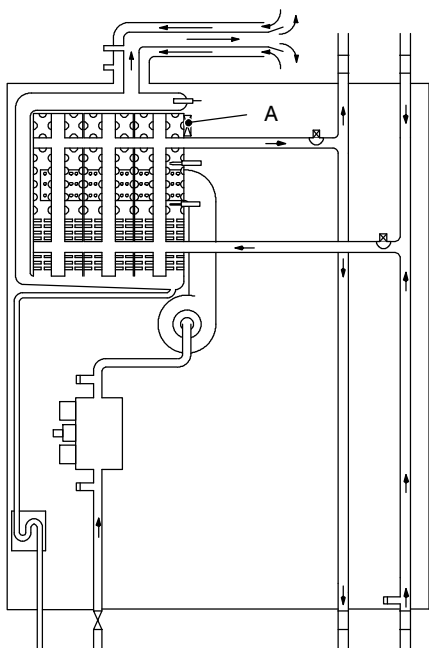

Fig. 12.1

12.2 Checks

- ✓ Overheat temperature value
- 1 Run the boiler and set the temperature at maximum by pressing the appropriate key.
- 2 Allow the boiler to reach its maximum operating temperature. The boiler should maintain a temperature below that of the safety thermostat and no overheat intervention should occur.

⚡ **Warning: isolate the boiler from the mains electricity supply before removing any covering or component.**

- ✓ Electrical function
- 1 Remove all the case panels.
- 2 Disconnect the safety thermostat and check its electrical function. Normally (no intervention) the contact must be closed (electrical resistance zero Ω).

12.3 Removal

⚡ **Warning: isolate the boiler from the mains electricity supply before removing any covering or component.**

- 1 Remove all the case panels.
- 2 Disconnect the wiring *B* (detail in Fig. 12.2).
- 3 Unscrew the screws *C* and remove the safety thermostat.

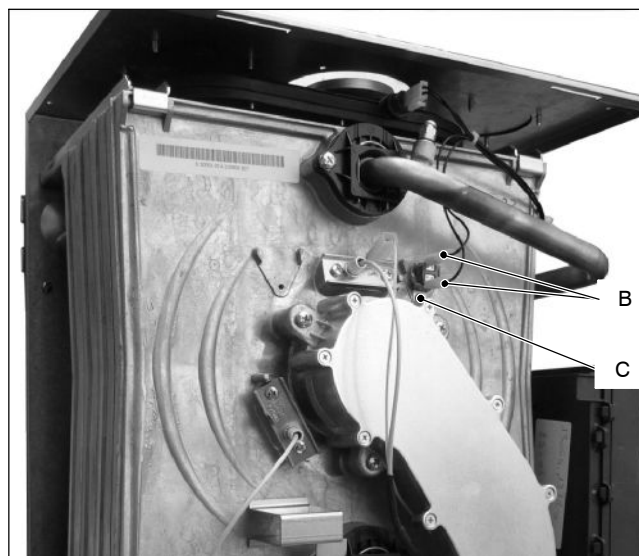

Fig. 12.2

- 4 Reassemble the safety thermostat carrying out the operations in reverse order.
- 5 Apply an adequate quantity of heat conducting compound between the condensing heat exchanger and the thermostat.

⚠ **Warning: After cleaning or replacement as detailed above, it is deemed necessary to undertake a combustion analysis as detailed in chapter 8.3 section 11.**

13 Flue temperature probe NTC and Safety thermal fuse

13.1 Function

The Flue temperature probe NTC A in Fig. 13.1 and Fig. 13.2 senses the temperature of the combustion products that flow through the condensing heat exchanger.

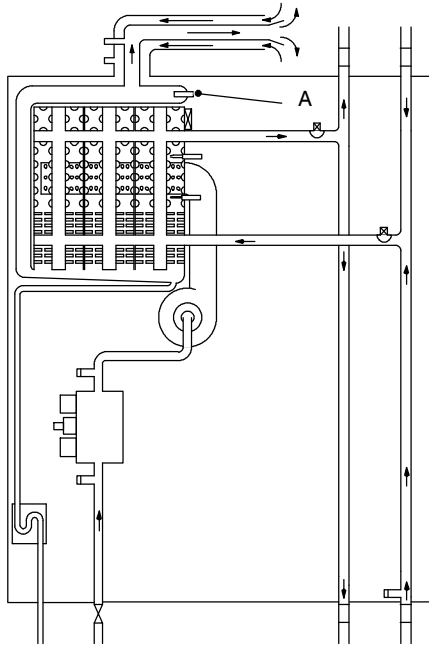

Fig. 13.1

If the temperature of the combustion products circuit reaches the limit temperature, the Flue temperature probe NTC reduces the gas flow rate to the burner. The temperature of the combustion products should decrease to a safe value temperature.

In the case that the temperature of the combustion products reaches a potentially dangerous value, it stops the boiler operation (lock-out).

This allows the use of plastic materials for the flue outlet pipes and bends.

The use of kits different from the original isn't however allowed, since the flue pipes are integral parts of the boiler.

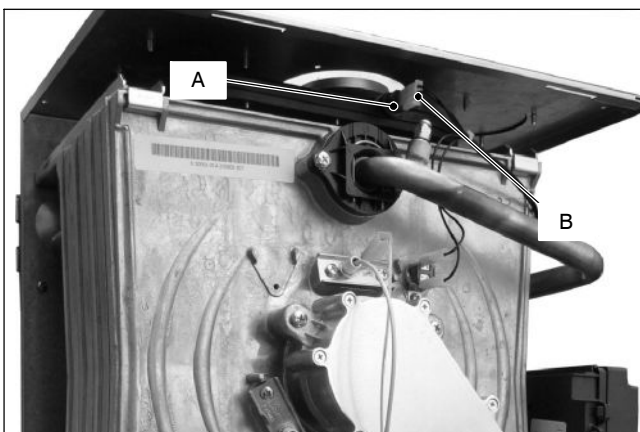

Fig. 13.2

13.2 Removal

Warning: isolate the boiler from the mains electricity supply before removing any covering or component.

- 1 Remove all the case panels.
- 2 Disconnect the connector B from the Flue temperature probe NTC by pressing the plastic hook placed on the side of the connector.
- 3 Unscrew and remove the flue temperature probe A (Fig. 13.2) from the condensing heat exchanger.
- 4 Assemble the Flue temperature probe NTC carrying out the removal operations in reverse sequence.

13.3 Checks

✓ Overheat temperature value

- 1 Run the boiler and set the temperature at maximum by pressing the appropriate key.
- 2 Allow the boiler to reach its maximum operating temperature. The boiler should maintain a temperature below that of the Flue temperature probe NTC and no overheat intervention should occur.

✓ Temperature-resistance relationship

- 1 Remove the Flue temperature probe NTC (see section 13.2).
- 2 Measure the Flue temperature probe NTC electrical resistance at the ambient temperature and check it according to the graph in Fig. 13.3

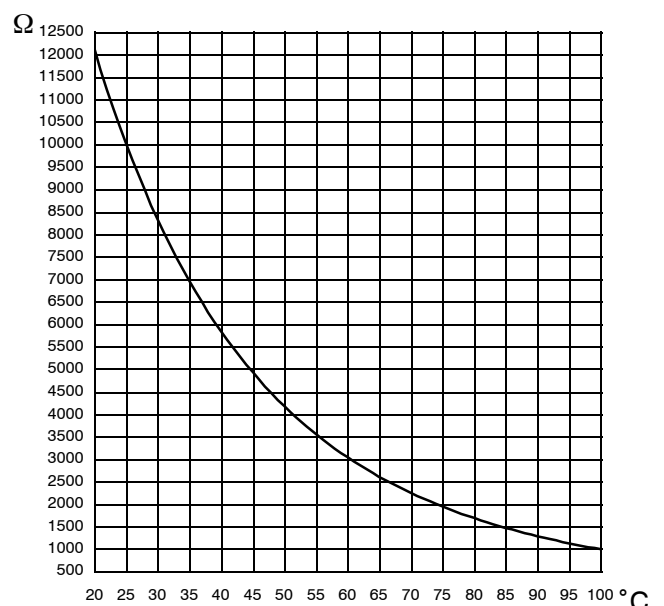

Fig. 13.3

14 Condensate trap

14.1 Function

The condensate trap *A* in Fig. 14.1 and Fig. 14.3 allows the discharge of the condensate via the condensate drain pipe avoiding in the mean time the escape of combustion products.

A plastic ball closes the trap outlet in case that the trap is empty.

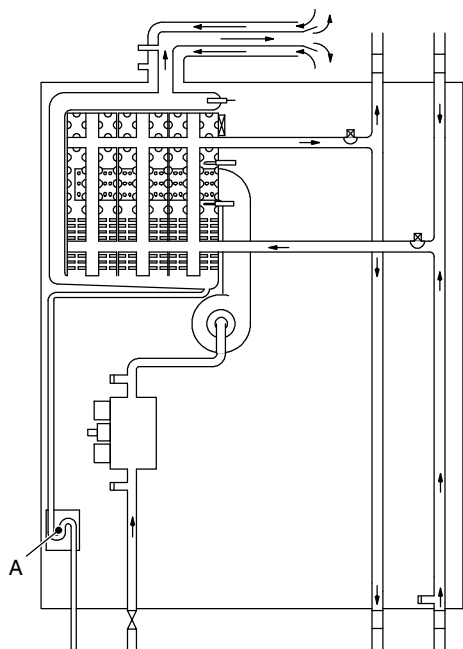

Fig. 14.1

If the drain pipe becomes blocked, or condensate cannot drain, the condensate level in the trap rises until it reaches the screw attached to the flame detection electrode, this will cause the boiler lock-out.

14.2 Check the cleanness of the trap

- 1 Unscrew the screws *B* and remove the plate *C* (Fig. 14.2).



Fig. 14.2

Unscrew the plug *D* on the bottom of the trap *A* and remove dirt eventually deposit (Fig. 14.3).

14.3 Removal

Warning: isolate the boiler from the mains electricity supply before removing any covering or component.

- 1 Remove the front and right case panels.
- 2 Unscrew the screws *B* and remove the plate *C* (Fig. 14.2)
- 3 Unscrew the threaded locking ring *E* and remove the flexible pipe *F* (Fig. 14.3).
- 4 Disconnect the electric connector *G* (Fig. 14.3 – Fig. 14.4)

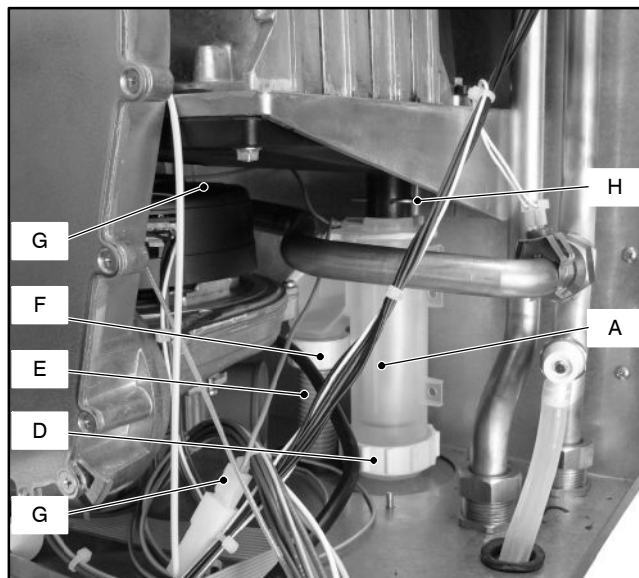

Fig. 14.3

- 5 Remove the forks *H* and remove the condensate trap *A* moving it downwards (Fig. 14.3).

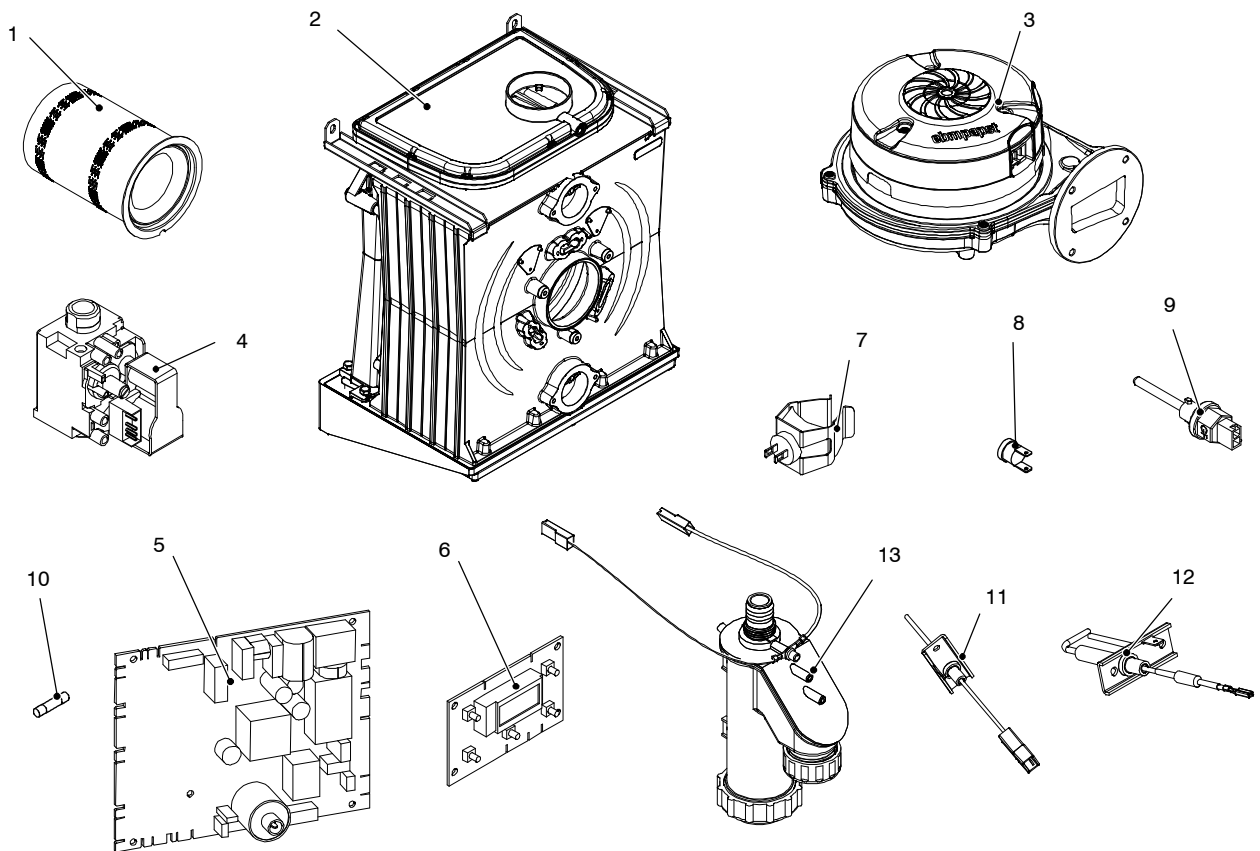

Fig. 14.4

- 6 Reassemble carrying out the removal operations in reverse order.

15 Short spare parts list

Key	G.C. part no.	Description	Q.ty	Manufacturer part no.	Manufacturer's reference
1		Burner (mod. Activ A 12OV, Activ A 15OV, Activ A 20OV)	1	BI1313 100	
		Burner (mod. Activ A 25OV)	1	BI1313 101	
2		Condensing heat exchanger (mod. Activ A 12OV, Activ A 15OV, Activ A 20OV)	1	BI1462 101	
		Condensing heat exchanger (mod. Activ A 25OV)	1	BI1462 102	
3		Fan	1	BI1313 102	
4		Gas valve	1	BI1313 103	SIT 848 Sigma 0848135
5		Main Electronic control/ignition p.c.b.	1	BI2035 113	
6		Control panel electronic p.c.b.	1	BI2035 101	
7		Temperature probe (main circuit)	1	BI1442 106	
8	E83-101	Overheat thermostat	1	BI1172 105	ELTH – type 261
9	H58-661	Flue temperature probe NTC	1	BI1432 102	
10	E23-792	Fuse 2 AF 250VAC 5x20	2	BI1165 112	
11		Detection electrode	1	BI1313 104	
12		Ignition electrode	1	BI1313 105	
13		Condensate trap	1	BI1462 104	





17962.2017.0 1710 36A4 UK

Biasi UK Ltd
Commercial Road
Leamore Enterprise Park
WALSALL
WS2 7NQ
Tel : 01922 714600
www.biasi.co.uk