

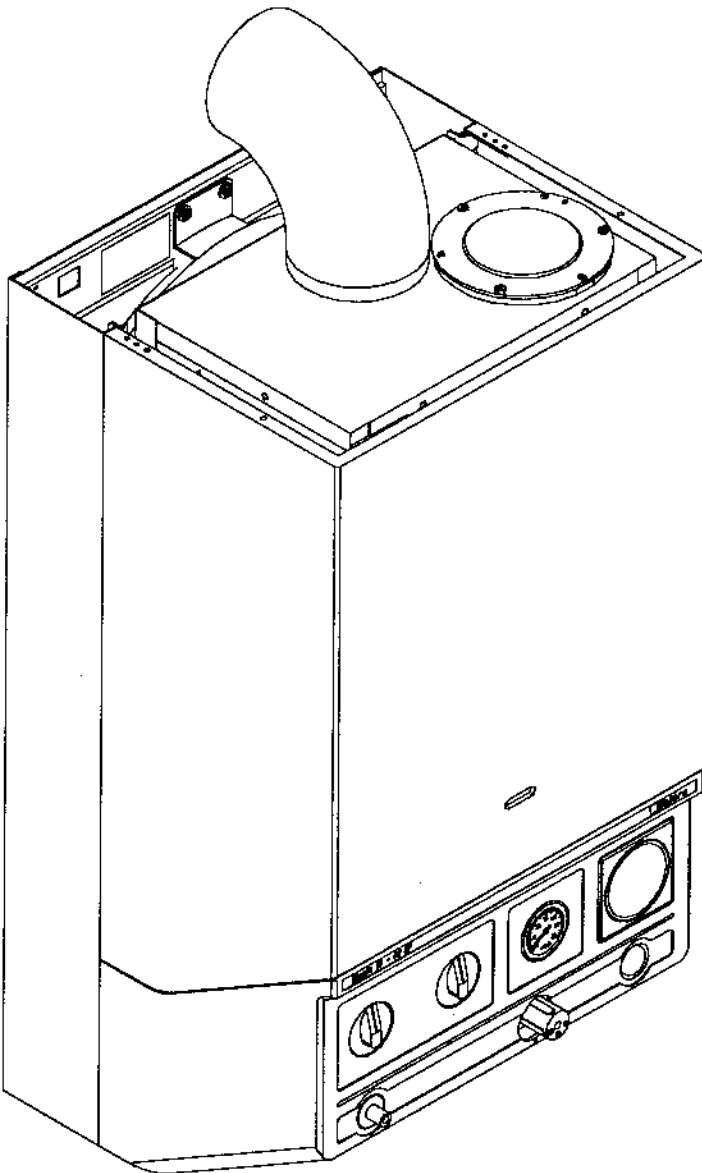

Vokèra

DOMESTIC HEATING APPLIANCES

Mynute 14/48SP



Installation and Servicing Instructions



British Gas Service Listed
G.C. No. 41 094 09

**HAND THESE
INSTRUCTIONS
TO THE USER**

This Appliance is for use
with Natural Gas only.



SECTION 1 INTRODUCTION

The Vokera 14/48 SP Mynute is a central heating boiler which by design incorporates a circulating pump, expansion vessel, safety valve, pressure gauge, automatic by-pass and permanent pilot.

It is produced as a room sealed category 12H appliance suitable for wall mounting applications only. It is provided with a fan powered flue outlet with an annular co-axial combustion air intake which can be rotated through 360 degrees. There is also a vertical flue option.

This appliance is designed for use with a sealed system only and is not intended for use on open vented systems.

The provision of stored domestic hot water is possible by the addition of an indirect cylinder with 'Y' or 'S' plan controls.

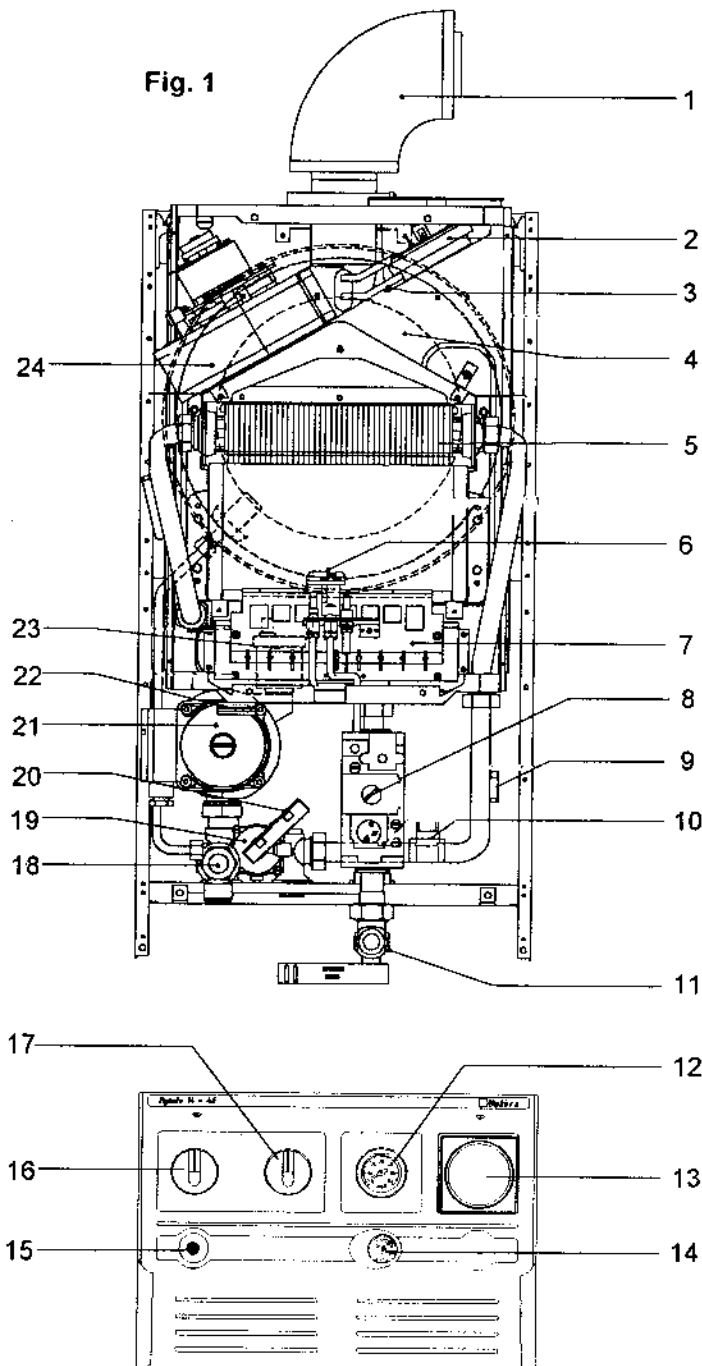

Fig.1 General Layout

- 1 Air Intake
- 2 Pressure Differential Switch
- 3 Silicone Pressure Tubes
- 4 Expansion Vessel
- 5 Main Heat Exchanger
- 6 Pilot Assembly
- 7 Main Burner
- 8 Gas Valve
- 9 High Limit Thermostat
- 10 Safety Thermostat
- 11 Gas Cock
- 12 Pressure Gauge
- 13 Time Clock Aperture (optional)
- 14 Gas Control knob
- 15 Piezo Ignitor
- 16 Mode Selector Switch
- 17 Boiler Thermostat
- 18 Safety Valve
- 19 Central Heating Manifold
- 20 Boiler Flow Switch
- 21 Pump
- 22 Fan Speed Resistor
- 23 Automatic Air Vent
- 24 Fan

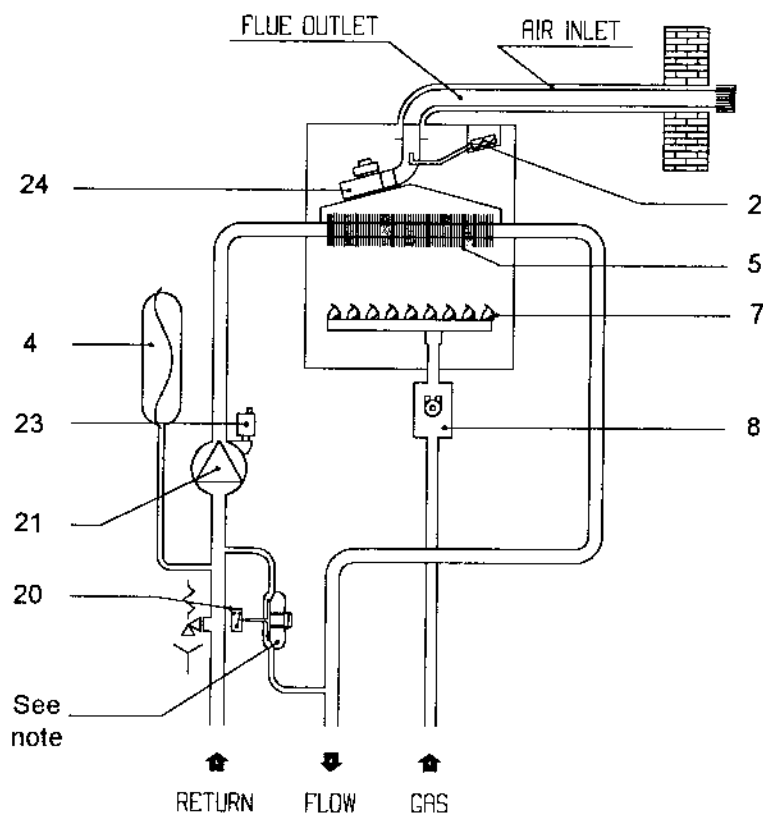

Fig. 2

Note

Differential pressure unit senses water flow rate to the pump and main heat exchanger and operates the flow switch.

SECTION 2 DESIGN PRINCIPLES AND OPERATING SEQUENCE

2.1 Fig. 1 illustrates the general layout of components. Fig. 2 illustrates the operating principles described below.

2.2 CENTRAL HEATING

2.2.1 With the pilot lit and the various switches and controls imposing a demand for heat, the pump is switched on, and the flow of water operates a flow switch at the same time the relay is energised via the control thermostat and pressure differential switch changes over energising the gas valve permitting gas flow and be ignited by the permanent pilot flame.

2.2.2 As water temperature increases this is sensed by the thermostat (17) which eventually operates to switch the burner off.

2.3 SAFETY DEVICES

2.3.1 (A) Differential pressure unit in the circuit which prevents burner operation if the water flow rate is too low.

(B) A high limit thermostat, which interrupts the control circuit shutting off the gas valve.
(C) At the same time the fan will still run.

2.3.2 A safety valve is provided to relieve excess pressure.

SECTION 3 TECHNICAL DATA

3.1 UNITS

Dimensions and values are given in the preferred SI Units with Imperial units in brackets where applicable.

3.2 DIMENSIONS AND CONTENTS

Height: 880mm (34.6in) overall (700mm casing)
 Width: 366mm (14.4in)
 Depth: 325mm (12.7in)
 Weight (empty 30.0kg) (full 31.0kg)
 Water content 0.8 litres (0.2 gals)

3.3 CONNECTION SIZES

Heating flow and return: Threaded tail for 22mm tap connector (not supplied)
 Gas Service Rc 1/2 (1/2in BSP int)
 Safety valve outlet: Rc 1/2 (1/2 BSP int)
 Flue outlet: nom. dia. 100mm specially supplied with boiler

3.4 INSTALLATION REQUIREMENTS

3.4.1 CLEARANCES

Minimum-above 225mm (9in)(above casing)
 Minimum-below 200mm (8in)(from casing)
 Minimum-in front 600mm (24in) (from casing)
 Minimum-at sides 25mm (1in.)(from casing)

3.4.2 Maximum heating system contents approx. 47 litres (10.4 gals) Acceptance capacity of expansion vessel 4.5 litres (1.0 gals)

3.4.3 Air supply/ventilation: To requirements of BS 5440 Part 2 1989.

3.4.4 Means of filling sealed system: To accord with BS and/or local Water Authority requirements.

3.4.5 The standard horizontal flue duct assembly allows a maximum length of duct as follows: Rear flue: 700mm (Wall thickness) Side flue: 890mm (to centre line of boiler)

Using extension tubes the flue may be extended to:

Horizontally: 4.5m max. in a straight line.

Vertically: 4.5m max. in a straight line (see cl. 5.5)

The maximum number of bends/offsets that may be used, and the reduction in flue length for each fitting are listed below (section 5.5.20) gives further details.

BEND	REDUCTION IN FLUE LENGTH FOR EACH BEND	MAX. BENDS
90° *	750mm	2
45°	375mm	4
OFFSET	750mm	2

* 90° Bend not to be used on vertical flue

3.5 ELECTRICAL DETAILS

Mains supply 240/250v ~ 50Hz Fused 3A
 Power consumption: 190W

3.6 PERFORMANCE

Central Heating
 Nominal Heat Input
 Max. 16.9kW (57,680Btu/h)
 Min. 9.2kW (31,400Btu/h)
 Designed temperature rise 20°C

Nominal Heat Output
 Max. 13.9kW (47,440 Btu/h)
 Min. 7.3kW (24,910 Btu/h)
 Max. flow temperature 85°C

Max. Gas Pressure 11.2 mbar (4.41in wg)
 Min. Gas Pressure 3.5 mbar (1.37in wg)

Max. Gas Rate 1.63m³/h 57.6ft³/h
 Min. Gas Rate 0.88m³/h 31.3ft³/h

Working Pressures Heating System
 Maximum 1.5bar/15m.w.g./50ft w.g.
 Minimum 0.5bar/5m.w.g./16ft w.g.
 Safety valve setting 3bar/30m/102ft.

3.7 BURNER DETAILS

Main Burner: Polidoro type NP7
 Main burner injectors 7 x 1.30
 Pilot Burner: Polidoro.
 Pilot Injector: 27 (marking) 2 holes.

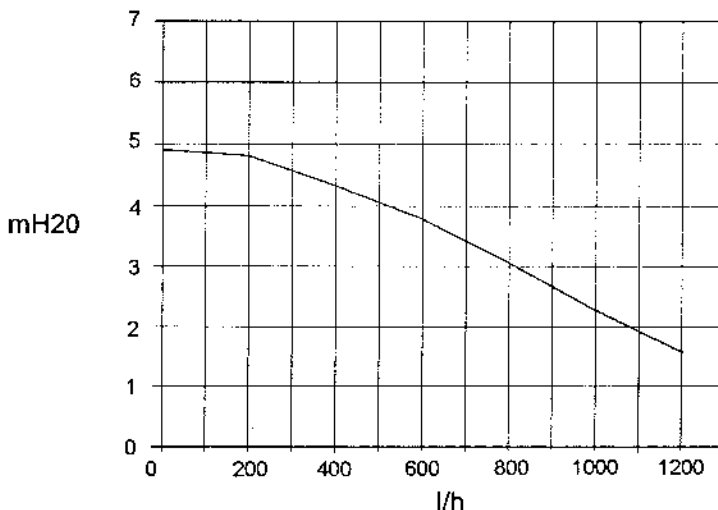

Fig. 3

Fig. 3 shows the residual pump head available for the central heating system after allowing for the pressure loss through the appliance.

SECTION 4 GENERAL REQUIREMENTS

4.0 GENERAL REQUIREMENTS

This appliance must be installed by a competent person in accordance with the Gas Safety (Installation and Use) Regulations 1984.

4.1 RELATED DOCUMENTS

The installation of this boiler must be in accordance with the relevant requirements of the Gas Safety (Installation and Use) Regulations, the Local Building Regulations, the current I.E.E. Wiring Regulations, the bylaws of the local water undertaking, and in Scotland, in accordance with the Building Standards (Scotland) Regulation.

It should be in accordance also with any relevant requirements of the local gas region and local authority and the relevant recommendations of the following British Standard Codes of Practice:

BS 6891		1988	Low pressure installation pipes
BS 6798		1987	Boilers of rated input not exceeding 60kW.
BS 5449		1990	Forced circulation hot water systems
BS 5440	Part 1	1990	Flues
BS 5440	Part 2	1989	Ventilation.

4.2 LOCATION OF APPLIANCE

This boiler may be installed in any room or internal space, although particular attention is drawn to the requirements of the current I.E.E. Wiring Regulations, and in Scotland, the electrical provisions of the Building Regulations applicable in Scotland, with respect to the installation of the boilers in a room or internal space containing a bath or shower.

Where a room-sealed appliance is installed in a room containing a bath or shower, any electrical switch or appliance control utilising mains electricity should be located in such a position that it cannot be touched by a person using the bath or shower.

The location chosen for a boiler must permit the provision of a satisfactory flue and termination. The location must also permit an adequate air supply for combustion purposes and an adequate space for servicing and air circulation around the boiler. Where the installation of the boiler will be in an unusual location special procedures may be necessary and BS 6798:1987 gives detailed guidance on this aspect.

A compartment used to enclose a boiler must be designed and constructed specifically for this purpose. An existing cupboard or compartment may be used provided that it is modified for this purpose.

Details of essential features of cupboard/compartment design including airing cupboard installations are given in BS 6798 1987 and BS 5440 pt 2 1989. These appliances are not suitable for external installation.

4.3 GAS SUPPLY

A gas meter is connected to the service pipe by the local gas region or a local gas region contractor. An existing meter should be checked, preferably by the gas region to ensure that the meter is adequate to deal with the rate of gas supply required for all appliances it serves. Installation pipes should be fitted in accordance with BS 6891.

Pipework from the meter to the boiler must be of adequate size. Pipes of a smaller size than the boiler inlet connection should not be used.

The complete installation must be tested for soundness as described in the above code.

N.B. If the gas supply for the boiler serves other appliances ensure that an adequate supply is available both to the boiler and the other appliance(s) when they are in use at the same time.

4.4 FLUE SYSTEM

The terminal should be located where dispersal of combustion products is not impeded and with due regard for the damage or discoloration that might occur to building products in the vicinity (see fig 4).

In cold and/or humid weather water vapour may condense on leaving the flue terminal. The effect of such steaming must be considered.

For protection of combustibles, refer to BS 5440:1 where the terminal is less than 2m (6.6ft) above a pavement or platform to which people have access (including any balcony or flat roof) the terminal must be protected by a guard of durable material.

A suitable guard is manufactured by G.R. Claudio (Vokèra) Ltd. Part No 018, (GC No 301 106). This guard must be fitted centrally over the terminal.

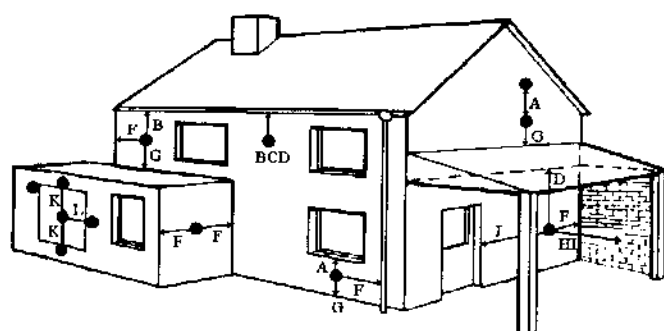

Fig. 4

Terminal position for fan assisted boiler (minimum distance)

	mm
A - Directly below an open window or other opening (e.g. air brick)	300
B - Below gutters, soil pipes or drain pipes	75
C - Below eaves	200
D - Below balconies or car port roof	200
E - From vertical drain pipes and soil pipes	75
F - From internal or external corners	300
G - Above ground or below balcony level	300
H - From a surface facing a terminal	600
I - From a terminal facing a terminal	1200
J - From an opening in the car port (e.g. door window) into dwelling	1200
K - Vertically from a terminal on the same wall	1500
L - Horizontally from a terminal on the same wall	300

4.5 AIR SUPPLY

Recommendations for air supply are detailed in BS5440:2;1989. The following notes are intended for general guidance.

The roomsealed fan flued boiler does not require a permanent air vent for combustion air supply.

Where installed in a cupboard or compartment ventilation is required for cooling.

The table shown gives the recommended minimum effective areas of such air vents.

POSITION OF AIR VENTS	AIR VENT AREAS	
	AIR FROM ROOM OR INTERNAL SPACE	AIR DIRECT FROM OUTSIDE
HIGH LEVEL	154 cm ² 23.9 in ²	77 cm ² 12.0 in ²
LOW LEVEL	154 cm ² 23.9 in ²	77 cm ² 12.0 in ²

- N.B.**
- Both vents must either communicate with the same room or space or be on the same outside wall.
 - Where vents communicate with an adjacent internal space, it is suggested that the space is adequately ventilated.

4.6 WATER CIRCULATION

4.6.1 Detailed recommendations are given in BS 6798:1987 and BS 5449:1990 (for smallbore and microbore central heating systems). The following notes are given for general guidance.

4.6.2 PIPEWORK

Copper tubing to BS 2871:1:1971 is recommended for water pipe. Jointing should be either by capillary soldered or with compression fittings.

Where possible, pipes should have a gradient to ensure air is carried naturally to air release points and water flows naturally to drain taps.

It should be ensured as far as possible that the appliance heat exchanger is not a natural collecting point for air.

Except where providing useful heat, pipes should be insulated to prevent heat loss and to avoid freezing. Particular attention should be paid to pipes passing through ventilated spaces in roofs and under floors.

4.6.3 BY-PASS

An automatic by-pass is incorporated in the boiler and systems should be designed to ensure that with only one radiator turned on a flow rate of at least 350 litres/hour (1.28 gals/min) is achieved through the boiler. See clause 6.10.4.

4.6.4 SYSTEM DESIGN

Figs 5 & 6 illustrate typical heating only layouts, but the boiler is also suitable for installation with a 'Y' or 'S' plan system.

Figures 7 & 8 illustrate layouts.

Section 10 appendix (C) gives wiring details.

4.6.5 DRAINING TAPS

These must be located in accessible positions to permit the draining of the whole system. The taps must be at least 15mm nominal size and manufactured in accordance with BS 2879:1980.

SALIENT FEATURES OF EACH SYSTEM

2 PIPE

- Radiators connected in parallel
- Water flow to each directly affected by pump
- Shutting off radiators affects total flow in system
- Radiators have approx. same mean temperature
- Low flow rate affects all radiators equally

1 PIPE

- Each radiator is on individual circuit off main pipe
- Water flow not directly affected by pump.
- Flow in each radiator depends on thermosyphon + pressure differential between connection to main circuit.
- Shutting off individual radiators hardly affects total flow in system.
- Radiator mean temperature progressively drops around systems.
- Low flow rate seriously affects last radiators on circuit.

N.B. Vokera Ltd recommend a 2-pipe system. Single pipe systems are more liable to be troublesome unless carefully designed and installed.

4.6.8 FILLING POINT

A method for initially filling the system and replacing water lost during servicing must be provided, and it must comply with local water authority regulations. A method is shown in fig. 9 using the Vokera filling loop which is acceptable in most areas. In the event that this method is not suitable in a particular area, contact the local authority for preferred methods.

N.B. The installer should ensure that no leaks exist as frequent filling of the system could cause premature scaling of the main heat exchanger

4.7 ELECTRICAL SUPPLY

The appliance is supplied for operation on 240/250V ~50Hz electricity supply. It should be protected with a 3-amp fuse.

THIS APPLIANCE MUST BE EARTHED.

The method of connection to the mains electricity must allow complete isolation from the supply.

The preferred method is by using a fused double pole switch with a contact separation of at least 3mm.

The switch must supply ONLY the appliance and immediate electrical control circuits (e.g. programmer/room thermostat)

Alternatively, use an unswitched shuttered socket outlet with a fused 3-pin plug both complying with BS 1363.

4.6.6 AIR RELEASE POINT

These must be fitted at all high points where air will naturally collect, and must be sited to facilitate complete filling of the system.

4.6.7 EXPANSION VESSEL

The appliance has an integral sealed expansion vessel to accommodate the increase of water volume when the system is heated. It can accept up to 4.5 litres (1.0 gals) of expansion water.

If the appliance is connected to a system with an unusually high water content, calculate the total expansion and add additional sealed expansion capacity as appropriate.

In general, modern systems will present no problem.

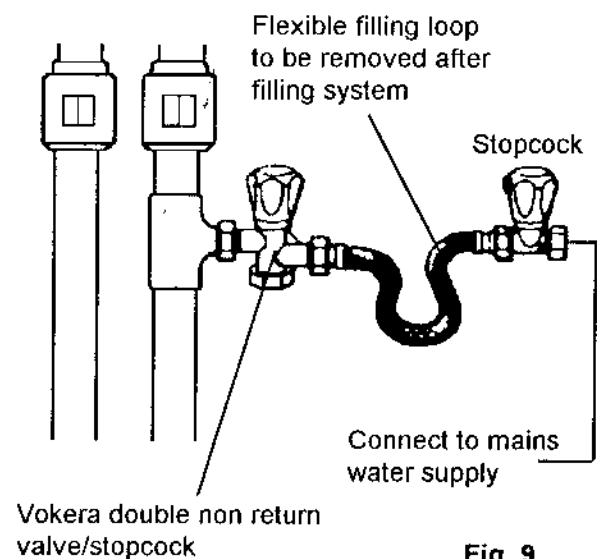

Fig. 9

SECTION 5 INSTALLATION

5.1 DELIVERY

The appliance is delivered in a heavy duty cardboard carton. A template is printed on the inside flap of the carton. This should be carefully cut out and used prior to installation to mark the locations for fixing holes for the upper bracket and the flue.

Packed with the boiler are:

- 1 - Hanging bracket
- 1 - Fittings pack containing:
 - Central heating valves (2)
 - Gas service tap (1)
 - Fibre washers (2)
- 1 - Installation Manual.
- 1 - Users Instructions

5.2 UNPACKING

- 5.2.1 Open the top of the carton and remove accessories and top packing.
- 5.2.2 Lay the carton with the words 'truck here' on the floor, restrain the carton, grip the black frame (not the flue or casing) and withdraw the appliance.

5.3 PREPARING FOR MOUNTING

- 5.3.1 Release the centre screw of the gas control knob and pull knob forward remove the 2 screws securing the lower control panel to the upper outer casing. (Fig.10)
- 5.3.2 Lower the control panel, disengage the outer casing from the 2 locating pins at the bottom left and bottom right corners by pulling the casing forwards. Slightly lift the casing to disengage from the top suspension hooks.
- 5.3.3 Ensure the casing, control knob and screws are put to one side in a safe place.

- 5.3.4 Loosely fit (hand tight) the valves and fittings using the washers supplied (Fig.10a).

5.4 MOUNTING THE APPLIANCE (Ref. Fig.11)

- 5.4.1 Place the template on a smooth, vertical, non-combustible surface and use it to locate the upper bracket, bottom fixing and flue pipe hole. Alternatively, position bracket and holes to dimensions in Fig. 11.
NOTE: (If the appliance is to be fitted on a wall of combustible material, the wall must be protected by a sheet of fireproof material).
If the appliance is to be fitted in a timber framed building it should fitted in accordance with the British Gas publication 'Guide for Gas Installations in Timber Framed Housing'. Reference DM2. If in doubt advice must be sought from the local Gas Region of British Gas.

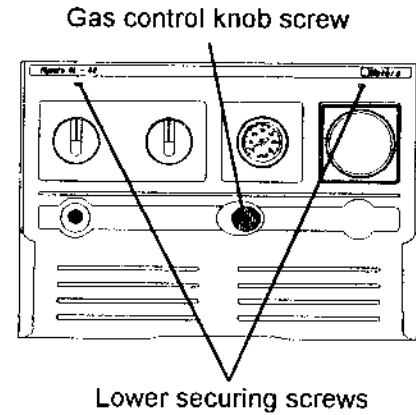

Fig.10

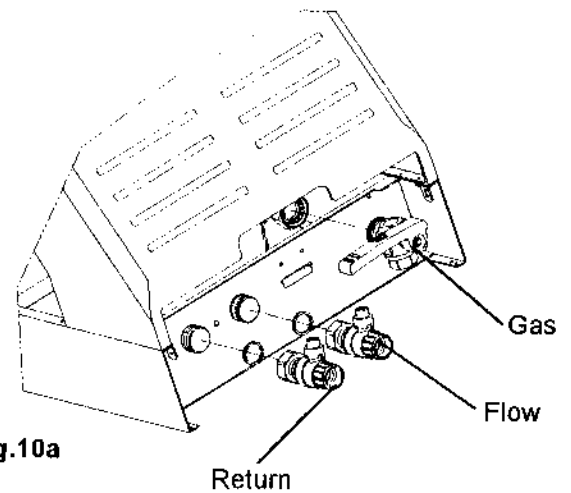

Fig.10a

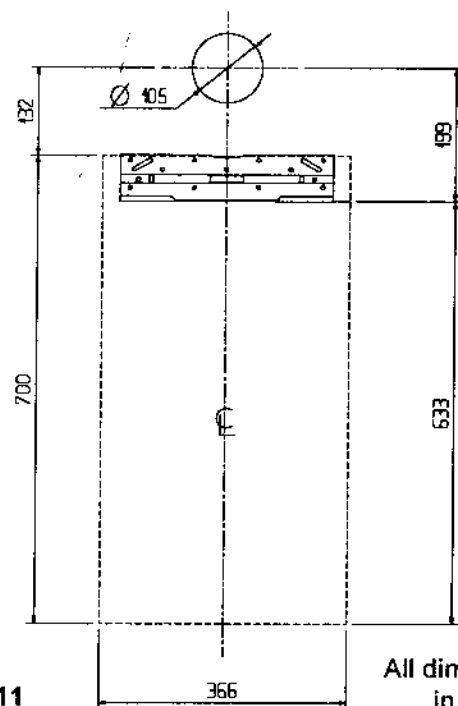

Fig. 11

All dimensions in mm

5.4.2 Drill and plug the wall for 2-2" No 10 screws for upper bracket and screw the bracket firmly into position using rust proof counter-sunk screws.

5.4.3 Hang the boiler on the bracket and adjust to final position.

5.4.4. Drill a 105mm hole through the wall to allow passage of the flue pipe

Refer to fig. 11 and figs. 12 - 16 for relevant dimensions for locating the hole. Where it is remote from the boiler take special care to ensure the hole is at the correct level so that the finished flue is horizontal.

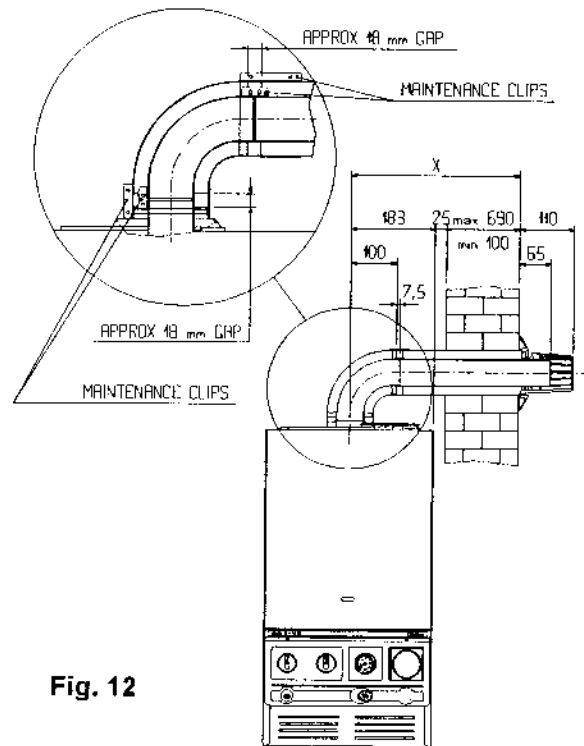

Fig. 12

5.5 FITTING THE FLUE

Vertical flue instructions are on pages 44-46 of this booklet

5.5.1 Refer to figures 12 - 16

5.5.2 The flue outlet elbow may be rotated 360 degrees on its vertical axis. The flue may be extended from this in the horizontal plane.

The standard flue pipe supplied may be used for lengths up to 890mm - from the outside of the wall to the centre of the flue elbow. Extension kits are available to order for flue extensions of up to 4.5 metres total length, in a straight line.

5.5.3 Hang the boiler on the bracket. Adjust the boiler sideways to its correct position. Locate the small maintenance clip on to the flue elbow (figs. 12 & 13) and assemble onto the flue outlet on the top of the boiler. Twist the flue bend to the outlet direction required, and tighten the maintenance clip to secure the flue bend in place. Carefully level across to check that the hole through the wall is at the same level as the flue bend.

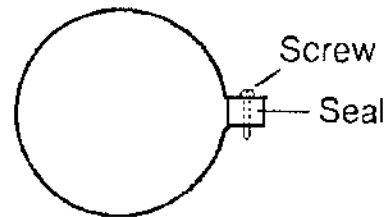

Fig. 13

5.5.4 Measure carefully from the actual face of the outside wall to the centre of the flue bend. (Dimension X on Figs 12 & 14)

5.5.5 The flue kit supplied is suitable for an exact dimension of 890mm.

5.5.6 Where X is less than 890mm, the supplied flue must be shortened as follows:- Subtract the measured length from 890mm. The difference is the precise length to be removed from the inner flue tube (890 - X = length to be cut off)

NOTE: The two tubes must be separated by removing screw G (fig. 15) before cutting. The outer air tube should also be shortened by the same amount to allow a gap for easy working (see inset on fig. 12).

EXAMPLE

X is measured as 630mm. Amount to be cut off inner tube is 890 - 630 = 260

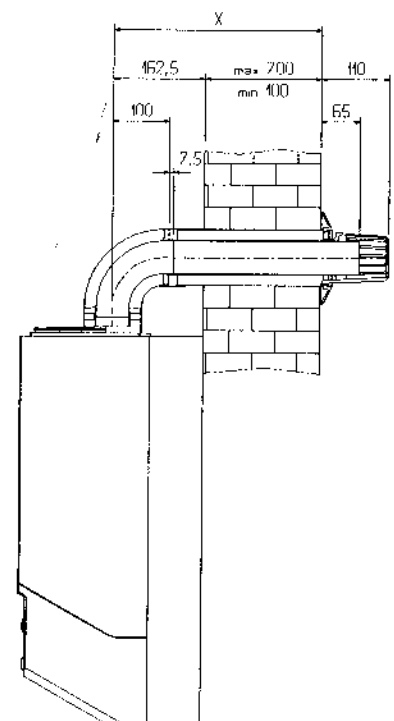

Fig. 14

5.5.7 Where X is more than 890mm an extension kit (or kits) is needed. The standard uncut length with extension(s) is as follows:-
 Supplied flue plus one extension 1740mm
 Supplied flue plus two extensions 2590mm
 Supplied flue plus three extensions 3440mm
 Supplied flue plus four extensions 4290mm
 Cut a fifth extension for a maximum length of 4.5metres.

The same procedure is followed:

1. Measure X
2. Subtract X from appropriate figure and shorten the last tube accordingly. X = 1295 so $1740 - 1295 = 445$

Shorten inner and outer tubes of last extension by 445mm

X = 1920 so $2590 - 1920 = 670$

Shorten inner and outer tubes of last extension 670mm

CUT CLEAN AND SQUARE WITH FINE TOOTH SAW AND REMOVE BURRS.

5.5.8 Loosen the small maintenance clip and lift off the flue bend

5.5.9 Ensure inner and outer terminal tubes are firmly fitted together with screw G (Fig. 15). Push the terminal tubes through the wall until the face of the outer tube protrudes 18mm from the face of the wall (Fig. 15). The terminal grill (D) will then protrude 110mm from the wall face.

5.5.10 If extension pieces are used assemble these using the maintenance clips provided.

5.5.11 Make sure the entire length of the flue is truly horizontal and adequately supported. Use at least one bracket for each extension. (Conventional adjustable strap supports suffice, Vokèra stockist can supply if necessary. Part No 03 (GC No 301 105)

5.5.12 Assemble the second small maintenance clip on the end of the inner flue tube.

5.5.13 Refit the flue elbow onto the boiler. Align the flue elbow with the flue pipe and tighten the maintenance clip between the flue elbow and the boiler.

5.5.14 Draw the flue pipe towards the boiler and tighten the second clip over the joint between the inner flue pipe and the flue elbow.

5.5.15 There must now be a gap of approximately 18mm from the elbow to the end of the outer tube.

5.5.16 Check also that the outer end of the flue projects as indicated in Fig. 15 or Fig. 16 if installed in a S.E. duct.

5.5.17 Referring to Fig. 12 fit the large maintenance clips into position and secure the clip screws.

5.5.18 Check adjust and tighten all supports.

5.5.19 Seal the peripheral gap around the outer tube with cement or mastic and slip the cosmetic flexible plastic collar (Fig. 15) item C) into groove on the pipe.

This operation can only be carried out with external access.

N.B. Absence of the collar will not affect operation of the appliance.

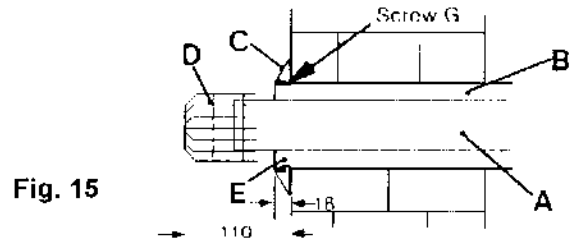

Fig. 15

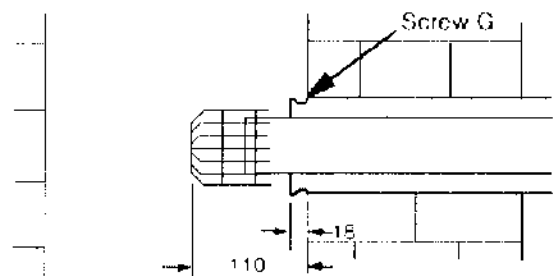

Fig. 16

S.E. DUCT INSTALLATION

5.5.20 **INSTALLING OPTIONAL 90° FLUE BEND**
 Part No. 02 (GC No 301 104)

5.5.21 Assemble the large and small maintenance clips as shown in Fig. 12.

5.5.22 Carry out steps 5.5.2-5.5.3

5.5.23 Ensure when siting the flue hole position that the total length of the straight flue pipe used does not exceed the maximum permissible. See chart under section 3.4.5.

NOTE: Extension kit(s) Part No. 026 (GC No. 370 346) will be required if the distance measured (Y + Z) is greater than 780mm.

5.5.24 Measure carefully the distance between the centre of the flue bend on the boiler to the centre of the hole through the wall (dimension X fig. 17).

5.5.25 Subtract 230mm from the measured dimension, separate the two tubes and cut the plain end of the outer tube to this dimension.

- 5.5.26 Cut the plain end of the inner tube 15mm longer than the outer tube.
- 5.5.27 Referring to Fig. 13 assemble a small maintenance clip on the outlet of the boiler flue bend. Push the inner flue tube into clip and tighten clip screws.
- 5.5.28 Slide the outer flue tube into place leaving approx. 18mm between the bend and the flue tube.
- 5.5.29 Referring to Fig. 12 fit the large maintenance clip into position and tighten clip screws.
- 5.5.30 Connect the flue tube to the extra bend using the same method ensuring that the bend outlet is in line with the hole through the wall.
- 5.5.31 Ensure that the flue pipe runs parallel to the wall then carefully measure the distance from the outside face of the wall to the centre of the extra bend (dimension W Fig. 17).
- 5.5.32 Subtract 97mm from the dimension and cut the outer tube to this length. NOTE: The two tubes must be separated by removing screw G Fig. 15 before cutting.
- 5.5.33 Ensure that any shortening of the tube is done from the plain end.
- 5.5.34 Reassemble the inner and outer flue tubes and refix screw G.
- 5.5.35 Mark the inner tube 7mm longer than the outer and cut off the inner tube at this point.
- 5.5.36 Remove the large maintenance clip, loosen the small clip and remove the bend.
- 5.5.37 Push the flue tubes through the wall, loosely refit the extra flue bend.
- 5.5.38 Assemble a small maintenance clip onto the inner flue tube, draw the flue tube towards the flue bend until the inner tubes butt. Tighten the screws on the small clip.
- 5.5.39 Referring to Fig. 12 fit the large maintenance clip into position and secure clip screws.
- 5.5.40 Check and adjust if necessary so that the outer flue tube protrudes 18mm from the outside face of the wall.
- 5.5.41 Tighten all maintenance clips, make sure that the entire flue is horizontal and adequately supported. Use at least one bracket (Part No 03, G.C. No 301 105) for each extension.

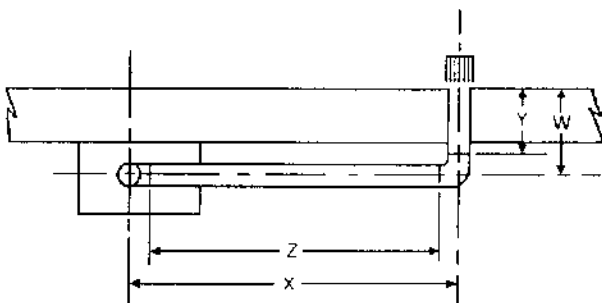

Fig.17

5.6 CONNECTING THE GAS AND WATER

5.6.1 Figs. 10a & 18 show the locations of the fittings.

5.6.2 Do not over tighten nuts and use another spanner to apply counter force to avoid damaging the appliance.

5.6.3 GAS SUPPLY

Connecting the gas supply.

Connect a 15mm gas pipe to the gas service tap and tighten the union nut securing the tap to the appliance.

5.6.4 CENTRAL HEATING

Connect the central heating pipework via 22mm tap connectors (not supplied) to the respective valves, right hand = flow, left hand = return, and tighten the nuts.

5.6.5 SAFETY VALVE DISCHARGE

The safety valve is located beneath the pump. It has a threaded outlet (Rc 1/2" BSP Int) to permit a discharge pipe to be connected.

When connecting, ensure the discharge pipe does not restrict access to or operation of the central heating valves. The discharge should terminate facing downwards exterior to the building in a position where discharging (possibly boiling) water will not create danger or nuisance; but in an easily visible position.

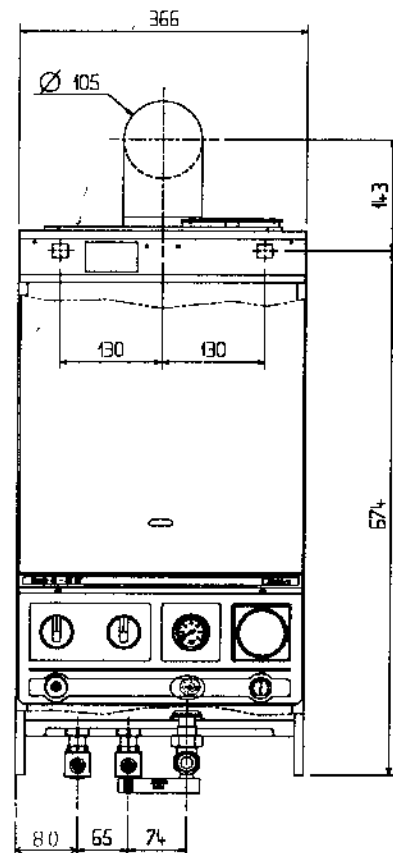

Fig. 18

5.7 ELECTRICAL CONNECTIONS

- 5.7.1 The electricity supply must be as specified in clause 4.7. If controls external to the appliance are required design of the external electrical circuits should be undertaken by a competent person.

See section 10 for further electrical wiring details.

Factory fitted internal wiring must not be disturbed when wiring external controls

N.B. IT IS ESSENTIAL THAT ALL EXTERNAL CONTROL CIRCUITS AND WIRING IS WIRED FROM THE SAME ELECTRICAL ISOLATOR AS SERVES THE APPLIANCE.

- 5.7.2 To gain access to the terminals release screw in centre of gas control knob (14) and pull end of control knob forward, release the 2 screws securing the lower control fascia to the upper outer casing.

Note these 2 screws are not captive. Ensure they are not lost.

The panel is bottom hinged. Lower the panel until it rests just past the horizontal position.

The terminal block is easily accessible inside the lower tray on the right hand side. Locate and unscrew two screws securing protective cover to terminals.

- 5.7.3 The electricity supply cable from the isolator and the appliance terminal block must be 3 core flexible sized 0.75mm² (24 x 0.2mm) to table 15-16 BS 6500.

Wiring to the appliance should be rated for operation in contact with surfaces up to 90°C.

- 5.7.4 Pass the cable through the cord anchorage and connect the wires Brown to L Blue to N and Green/Yellow to the earth connector on the input terminal block. Arrange the wires so that should the cable slip the anchorage the current carrying conductors become taut before the earthing conductor.

- 5.7.5 Securely tighten all terminal screws and arrange the cable with slack between the anchor and the terminal block. Tighten the cord anchorage.

- 5.7.6 Neatly arrange the external cable in such a way that unrestricted opening of the controls fascia is possible without strain on the cable.

- 5.7.7 External controls may be wired from terminals 1 and 3 of the controls terminal block (after removing the factory fitted link). If a neutral is needed use terminal N.

If required pass this cable through the same cord anchorage.

The conductors should be so connected that the conductor to terminal 1 becomes taut before those to 3 or Earth should the cable be strained.

SECTION 6 COMMISSIONING

6.1 Where the text bears identifying numbers in brackets, refer to figs. 1 and 2 unless otherwise instructed.

6.2 GAS SUPPLY INSTALLATION

Inspect the entire installation including the meter, test for soundness and purge, all as described in BS 6891.

6.3 CENTRAL HEATING SYSTEM

6.3.1 **IMPORTANT:** Do not release air from the red sealed expansion tank. It is charged with air at the factory to 1 bar (15psig).

6.3.2 INITIAL FLUSHING OF THE PIPEWORK

6.3.2.1 The appliance contains components likely to be damaged or blocked by grease and dirt from the system. It is recommended therefore that the appliance be disconnected from the system for the initial flush.

6.3.2.2 Close the appliance central heating valves (fig.10a) and disconnect from the appliance.

Connect a temporary water supply to the return and a drain pipe to the flow and flush the entire system until the drain discharges clean water (for at least five minutes).

Drain the system by opening the drain taps at all low points. Close the drain taps and reconnect the flow and return pipes to the appliance.

6.3.3 INITIAL FILLING OF THE SYSTEM

6.3.3.1 See Clause 3.4.4. and 4.6.8

6.3.3.2 Open central heating flow and return valves Unscrew the cap on the automatic air release valve (23) one full turn (leave open permanently).

6.3.3.3 Close all air release taps on central heating system.

6.3.3.4 Gradually open stopcock at the filling point connection to the central heating system until water is heard to flow. Do not open fully.

6.3.3.5 Starting with the lowest radiator open each air release tap in turn closing it when clear water, free of bubbles, flows out. In the same way release air from any high points in the pipework.

6.3.3.6 Continue filling the system until at least 1.5bar registers on the gauge (12) then turn off the filling stopcock.

6.3.3.7 Inspect the system for water soundness and remedy any leaks discovered.

6.3.4 SETTING THE SYSTEM DESIGN PRESSURE

6.3.4.1 The design pressure must be a minimum 10mH₂O and a maximum of 15mH₂O

6.3.4.2 The actual reading should ideally be 10mH₂O plus the height in metres to the highest point of the system above the base of the appliance (up to the maximum of 15mH₂O total).

N.B. The safety valve is set to lift at 3 bars (30m/45psig).

6.3.4.3 To lower the system pressure to the required value turn the red knob of the safety valve (18) a quarter turn to release water until the required figure registers on the gauge (12).

6.4 CHECKING ELECTRICITY SUPPLY

6.4.1 Carry out preliminary checks for earth continuity, polarity, short circuit and resistance to earth. (See page 43 for further details). Gaining access as required according to clause 5.7.2 in this manual.

6.4.2 Leave the appliance with the control fascia closed and secured and with the mains electricity switched OFF.

6.5 ESTABLISHING THE PILOT FLAME

6.5.1 Turn OFF the main electricity supply

6.5.2 Ensure the main gas supply is ON.

6.5.3 Turn ON the appliance gas service tap.

6.5.4 Press the gas control knob (14) and turn until the  symbol is towards the bottom. Repress the g.c. knob and hold it in. At the same time repeatedly press the peizo button (15) to light the pilot burner. Once a flame is seen through the viewing window, hold in the g.c. knob for a further 20 seconds then release the knob slowly.

6.5.5 The pilot flame should remain alight and envelope the thermocouple (see fig.19). if it goes out, wait 3 minutes and repeat from 6.5.4

N.B. Thermocouple output 12-15 mv

Fig. 19

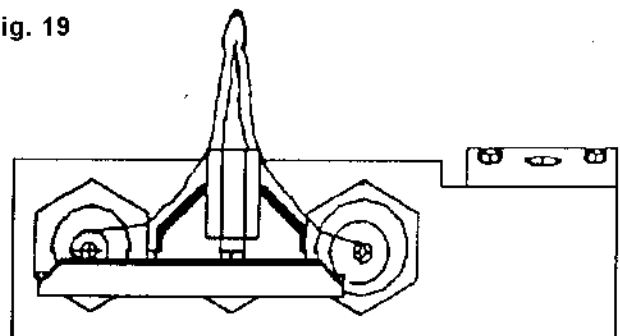



6.5.6 When the pilot flame is established, depress and turn g.c.knob (14) to show the  symbol at the bottom. Turn on the mains electricity and ensure the appliance mode selector switch is turned to rest. This permits slow speed operation of the flue fan to maintain the pilot.

6.5.7 Refer to fig. 19 and check that the pilot flame is correct. If it is necessary to adjust the flame refer to cl. 5.7.2 for access instructions. Fig. 21 shows the location of the adjustment screw. Turning clockwise decreases flame and vice versa.

6.6 LIGHTING THE BOILER

6.6.1 Before lighting, open flow and return valves (CI 6.3.3.2).

If external controls are fitted (e.g. timeclock and thermostat) ensure they 'call for heat'. The commissioning of the appliance may be easier if the external controls are temporarily disconnected and terminals 1 and 3 linked. (For access procedure turn off electricity and refer to clause 5.7.2 for instructions).

6.6.2 Ensure that the mains electricity is on and the appliance mode selector switch (16) is turned to . Ensure that the g.c. knob (14) shows the  symbol at the bottom.

6.6.3 Set the control thermostat (17) to the highest setting.

6.6.4 The boiler will now go through an ignition sequence and the burner will light.

N.B. The most common cause of failure to light is insufficient water flow. See cl. 4.6.3.

6.7 CHECK BURNER PRESSURE

(Before checking burner pressures allow the appliance to warm up for approx. 10 minutes).

6.7.1 The heat input is factory set to the maximum value given in section 3.6 but it is necessary to check/adjust this when commissioning.

The maximum heat input may be reduced by a simple adjustment to suit the system load.

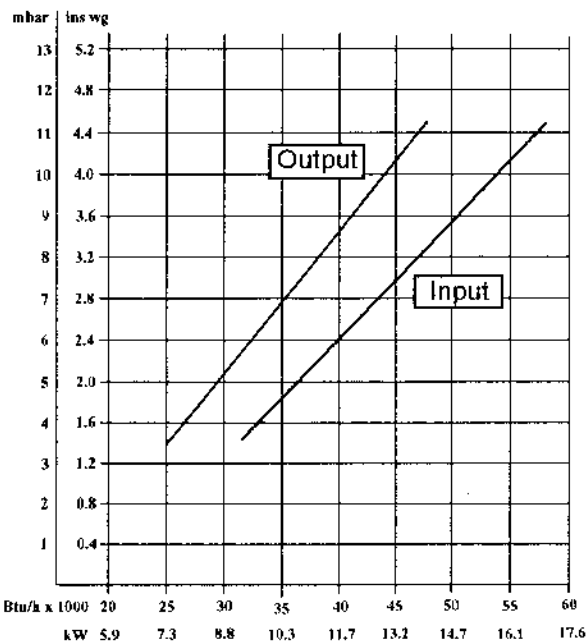

Fig. 20

Refer to fig 20 to determine the pressure for the heating output you need (e.g. for 35,000 Btu/h a pressure of 7 mbar is needed)

6.7.2 Turn off the main electricity supply. Gain access to the interior as instructed in clause 5.7.2.

6.7.3 Locate the main burner pressure test point (Fig. 21) and slacken the screw in an anti-clockwise direction. Attach a suitable pressure gauge. Turn on the boiler for central heating.

6.7.4 The pressure reading for maximum output should be:
11.2 mbar/4.40in wg (plus or minus 1.1mbar/ 0.40in wg).

If the pressure is wrong or if it is required lower it can be adjusted. Identify the regulating screw on the front of the gas valve (Fig. 21), turning the regulating screw clockwise will increase the pressure or turning the screw anti-clockwise will decrease the gas pressure. Once this pressure has been fixed it should be indelibly recorded on the label provided and stuck next to the data badge. This is to ensure that the burner can be reset when any service operation involves alteration of burner settings.

6.8 CHECKING THE FLUE SYSTEM

6.8.1 The flue system should be visually checked for soundness. Check all clamps and fixings are secure and tight.

6.9 CHECKING THE HEATING THERMOSTAT

6.9.1 Allow the system to warm up and manipulate the control thermostat to ensure the burner switches from 'on' to 'off' and vice versa (scale range covers approx. 45°C - 85°C).

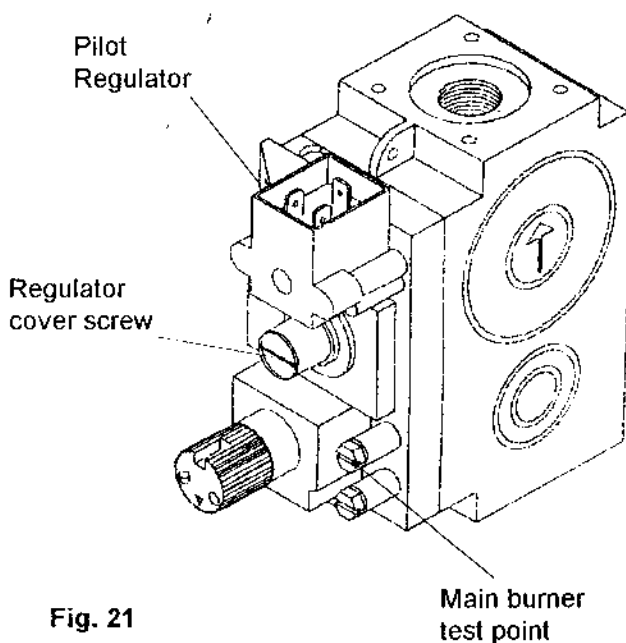

Fig. 21

6.10 REGULATING THE CENTRAL HEATING SYSTEM

- 6.10.1 Fully open all radiators and circuit valves and run the appliance in the central heating mode until heated water is circulating. If conditions are warm, remove any thermostatic valve heads.
- 6.10.2 If the burner will not light, ensure that water is in fact circulating. See cl 4.6.3.
- 6.10.3 Adjust radiator return valves and any branch circuit return valves until the individual return temperatures are correct and are approximately equal.
- 6.10.4 When all is adjusted, progressively close all radiator valves to ensure that the appliance still operates when flow through the system is limited. If the burner cuts out prematurely due to lack of water flow through the appliance, the system should be regulated to ensure a flow rate of at least 350 litres/hour (1.28 gals/min). This may mean the addition of a small manual by-pass being fitted to the system if a fully TRV system is used.

6.11 FINAL FLUSHING OF THE HEATING SYSTEM

- 6.11.1 After the system has been thoroughly heated to about 60°C (140°F) or above, and hot water has circulated to all parts, any residual grease flux and other foreign material will have been dislodged.
- 6.11.2 Inspect the system for soundness. Turn the appliance mode selector switch to off (Fig 1, 16).

Open all drain taps and quickly drain the system whilst still hot to remove offending substances. Refill as instructed in clause 6.3.3.

For further details on flushing systems refer to BS 7593 : 1992.

6.12 FINAL CHECK FOR OPERATIONS

- 6.12.1 Disconnect pressure gauge, tighten screw. Relight boiler.
- 6.12.2 Re-check for gas soundness.
- 6.12.3 Re examine heating system for water soundness.
- 6.12.4 Check the appearance of the gas flame to assess adequacy of combustion air supply.
- 6.12.5 Re-check the flue system for soundness and adequacy of supports.

6.13 CONCLUDING OPERATIONS

- 6.13.1 If external controls have been disconnected and terminals 1 and 3 temporarily linked remove the link and reconnect the external control circuit, check the operation of the external controls.

6.14 REFIXING THE FRONT CASING. (Fig. 22)

- 6.14.1 Offer up the front casing to the back frame in a near vertical attitude and locate the hooks on the casing over the hooks on the frame. Slide the casing downwards to fully engage the hooks, locate the bottom of the case onto the lower lugs and push home. Lift the lower control facia into place and replace the 2 screws.

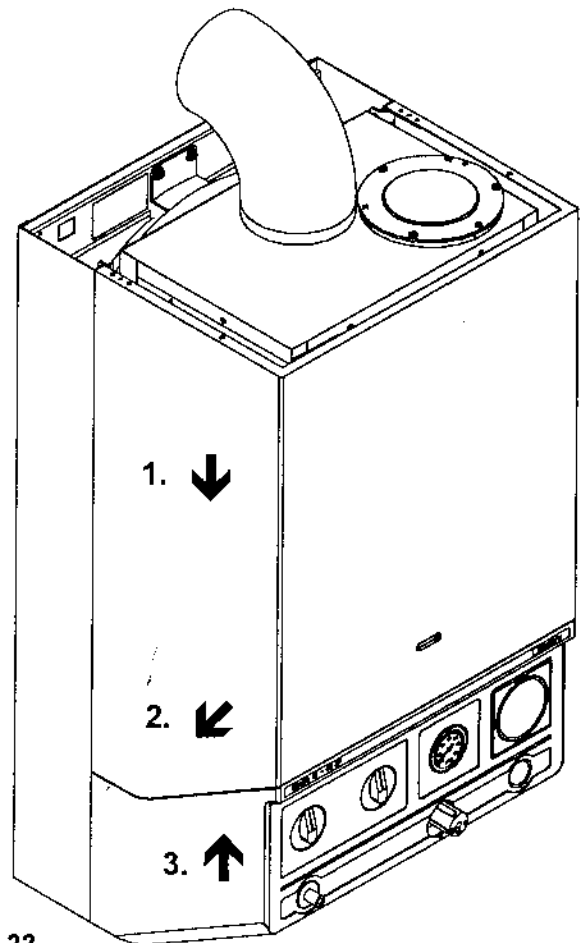

Fig. 22

SECTION 7 INSTRUCTING THE USER

- | | | | |
|-----|-------------------------------------------------------------------------------------------------------------------------------------------------------------------------------------------------------------|-----|---------------------------------------------------------------------------------------------------------------------------------------------------------------------------------------------------------|
| 7.1 | Hand over the copy of the user instructions supplied together with this installation book, and explain how to operate the boiler correctly. Explain how to use the timeclock and room thermostat if fitted. | 7.4 | Inform the user of the location of all drain cocks and air vents. |
| 7.2 | Show the user how to switch off the appliance quickly and indicate the position of the electric supply isolator. | 7.5 | Explain how to turn the appliance off for both long and short periods and advise on the precautions necessary to prevent damage should the appliance be inoperative when freezing conditions may occur. |
| 7.3 | Explain that air supply grilles must not be blocked in any way. | 7.6 | Finally advise the user that, for continued safe and effective operation, the appliance must be serviced by a competent person at least once a year. |

N.B. EXPLAIN TO THE USER THAT MANUAL RELIGHTING OF THE PILOT MAY BE NECESSARY FOLLOWING INTERRUPTION OF THE ELECTRICITY SUPPLY.

SECTION 8 SERVICING INSTRUCTIONS

8.1 GENERAL

To ensure efficient safe operation of the appliance it is necessary to carry out routine servicing at regular intervals.

The frequency of servicing will depend upon the particular installation conditions and usage but in general once per year should be adequate. It is the law that all servicing work is carried out by a competent person such as British Gas or other CORGI registered personnel.

The following instructions apply to the boiler and its controls, but it should be remembered that the central heating system will also require attention from time to time.

8.2 IMPORTANT NOTES

WARNING: Having carried out preliminary flame checks and before starting any servicing work, switch OFF the mains electricity supply and disconnect the plug at the main isolating switch and socket. (If a switch is used remove the fuse.)

Turn off gas supply at the gas service tap fitted to the appliance.

Always test for gas soundness after any service work and after exchanging any gas carrying component.

8.3 RECOMMENDED ROUTINE SERVICING

8.3.1 ANNUAL SERVICING

The following procedures should be carried out at least once per year.

1. Inspect exterior for signs of damage and deterioration particularly of flue pipework and electrical connections.
2. Inspect air supply and ventilation arrangements comparing them with the requirements laid down in clauses 4.5 to ensure no alterations have been made since installation.
3. Turn off mains electricity and remove front casing (see clause 8.4).
4. Replace fuse if previously removed (8.2 above) and turn on electricity, run the boiler for a few minutes to permit inspection of its operation, inspect the burner for yellowing of flame tip, flame lift off or sooting.
5. Ensure central heating valves (fig.10a) are open. Note these are $\frac{1}{4}$ turn valves which are open when the line on the square shank is vertical, closed when line is horizontal.
Observe pressure gauge reading (fig. 1 no. 12) which should be approximately 10 mbar when the system is cold (see clause 6.3.4).
6. Turn off mains electricity and turn off gas service tap on the appliance.
7. Gain general access as described below in clause 8.4.
8. Remove pilot burner assembly and brush clean. Inspect pilot injector and blow clean (see cl 8.6.7).
9. Remove main burner. cl 8.6 to 8.7.6 Lightly clean with a soft brush and inspect for damage. If during initial inspection, any combustion irregularity was suspected, remove injectors and clean or replace (see clause 8.7).
10. Place cloth below combustion chamber to catch debris. Clean heat exchanger using suitable brushes and rods if necessary.
11. Inspect combustion chamber lining. The insulating material is easily damaged. Do not scrape, but clean off lightly.
If any panels are damaged these should be replaced (see Clause 8.11).
12. Replace all parts in reverse order but leave the controls fascia open and outer casing off.
13. Undertake a complete commissioning check as detailed in section 6.
14. Refix the front casing and close up the lower control panel.
15. Clean off casing using soft cloth and dilute detergent.

8.3.2 REPLACEMENT OF PARTS

The life of individual components varies and they will need servicing as and when faults develop. The fault finding sequence charts in section 9 will serve to locate which component is the cause of any malfunction, and instructions for removal, inspection and replacement of the individual parts are given in the following pages.

**8.4 TO GAIN GENERAL ACCESS/
REASSEMBLY**

To remove components access to the interior is essential.

Refer to figs. 23 & 24

Ensure gas and electricity supplies are isolated before carrying out any servicing.

8.4.1 To lower the control facia.

Release the centre screw of the gas control knob and pull knob forward, remove the 2 screws securing the lower control facia to the upper outer casing, the lower control facia will now hinge downwards. (Fig. 23)

8.4.2 To remove the upper outer casing disengage the 2 locating pins at the bottom left and bottom right corners by pulling the casing forwards. Slightly lift the casing to disengage from the top suspension hooks. (Fig. 24)

8.4.3 Reassembly is always carried out in reverse order to dismantling, unless otherwise stated. Electrical connections must be remade in accordance with the wiring diagram fig.40.

8.4.4 Wherever gas control components are replaced, check the burner pressures and adjust if necessary. cl. 6.7.

8.5 ROOM SEALED CHAMBER FRONT COVER (including viewing window)

Part No 5957 Refer to fig. 25

8.5.1 Gain general access as 8.4

8.5.2 Remove room sealed front cover plate by releasing six screws (fig. 25) and easing cover off. The screws are not captive. inspect gasket for damage. If damaged, replace.

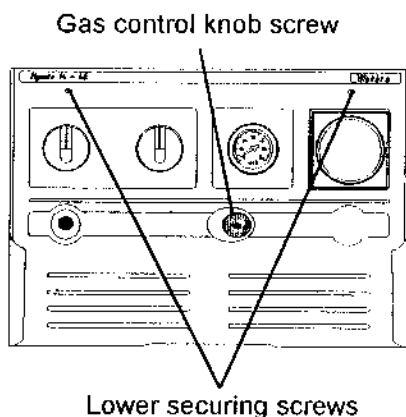

Fig. 23

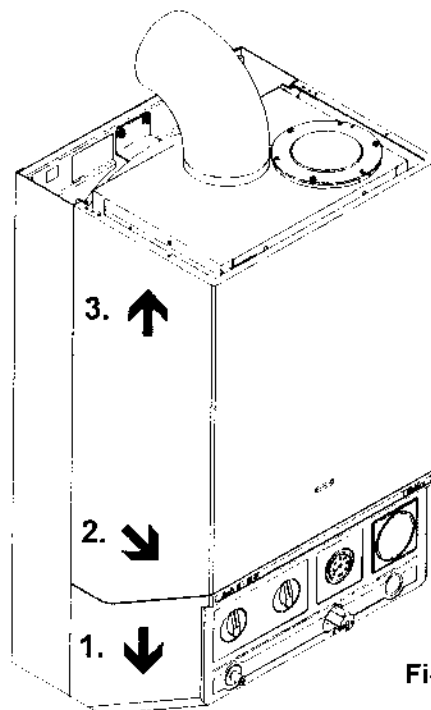

Fig. 24

- 1. Lower the control facia.
- 2. Pull the outer casing forwards to disengage the lower locating pins.
- 3. Slightly lift casing to disengage from the top suspension hooks.

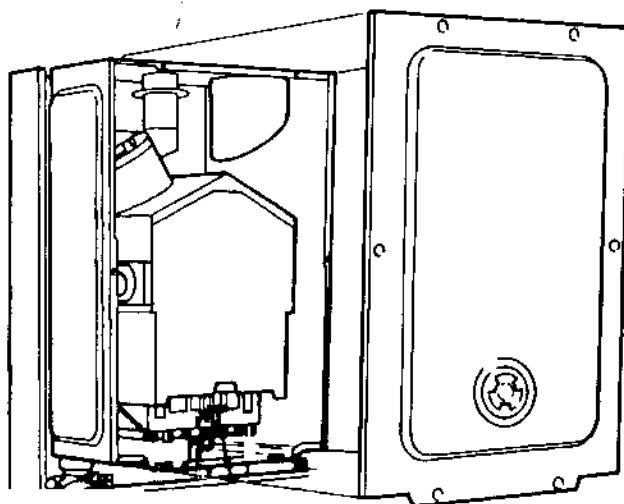
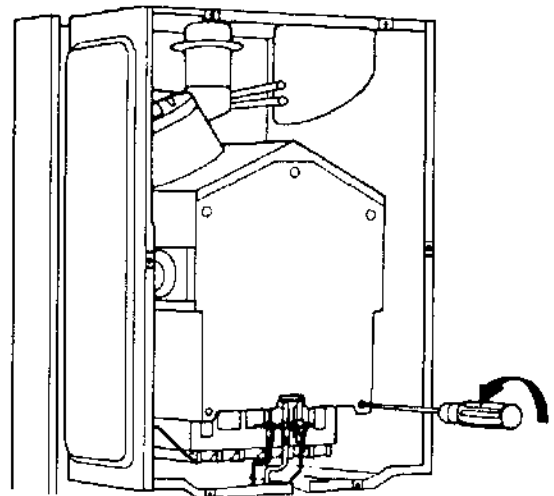

Fig. 25

8.6 TO REMOVE /REPLACE ELECTRODE, THERMOCOUPLE AND PILOT BURNER
Refer to Figs. 26,27 & 28

Fig. 26



- 8.6.1 Gain general access as 8.4.
- 8.6.2 Remove room-sealed chamber front cover plate as 8.5.2.
- 8.6.3 Remove front of combustion chamber by releasing five screws (fig. 26).
- 8.6.4 **TO REMOVE PILOT BURNER ASSEMBLY**
- 8.6.4.1 Pull off electrode lead.
- 8.6.4.2 Disconnect pilot pipe and thermocouple at gas valve end.
- 8.6.4.3 Release screw securing pilot burner assembly. (fig. 27). Ease pilot burner assembly and pipe forward, sliding rubber gasket from frame. Remove electrode, thermocouple and pilot pipe.

8.6.5 REMOVE ELECTRODE

- 8.6.5.1 Pull off electrode lead.
- 8.6.5.2 Unscrew electrode retaining nut.
- 8.6.5.3 Remove electrode.

8.6.6 TO REMOVE/REPLACE THERMOCOUPLE

- 8.6.6.1 Remove pilot burner assembly (8.6.4). Unscrew retaining nut at burner end and pull out probe. ease it through the rubber gasket.
N.B. Retaining nut is compression fit and slides off the probe in an upwards direction.

- 8.6.6.2 If a new thermocouple is to be fitted, bend it to approximate shape of old one and replace in reverse order.
N.B. Make sure rubber gasket is intact and properly fitted to boiler case to ensure an air tight seal.

8.6.7 TO REMOVE/REPLACE PILOT BURNER AND/OR INJECTOR

- 8.6.7.1 Remove pilot assembly (8.6.4)-(8.6.6.2)
- 8.6.7.2 Unscrew pilot supply pipe union, and withdraw pipe.
N.B. Pilot injector is held captive by bush on the end of the connecting pipe. it may drop out as the pipe is removed.

- 8.6.7.3 Reassemble in reverse order ensuring correct engagement of pips on pilot assembly

8.7 MAIN BURNER/INJECTORS

- 8.7.1 Gain general access as (8.4 & 8.5.2)
- 8.7.2 Remove combustion chamber front (8.6.3).
- 8.7.3 Remove pilot assembly as 8.6.4
- 8.7.4 Remove four burner retaining screws (see fig. 28).
- 8.7.5 Remove main burner and unscrew injectors.
- 8.7.6 Reassemble in reverse. order.

Fig. 27

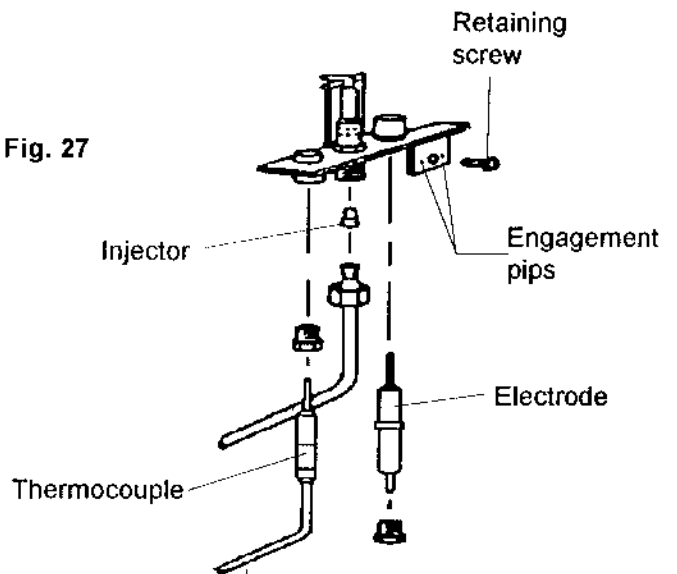
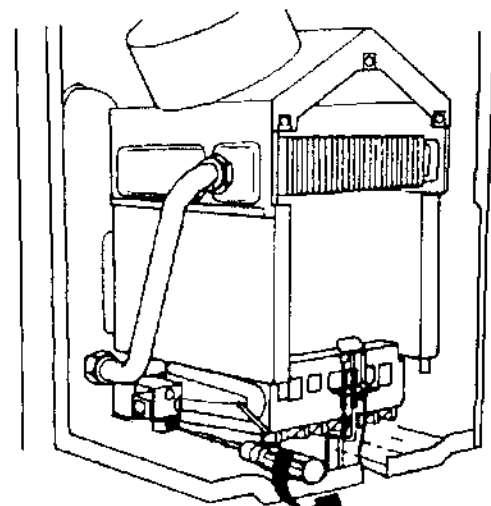

Fig. 28



8.8 MAIN HEAT EXCHANGER

Part No 5388 Refer to fig. 29.

- 8.8.1 Gain general access as 8.4.
- 8.8.2 Remove room-sealed front cover plate as 8.5.2
- 8.8.3 Remove front of combustion chamber as 8.6.3.
- 8.8.4 Remove both side panels, 2 screws each and slide panels forwards.
- 8.8.5 Close heating flow and return valves fig. 10a by turning $\frac{1}{4}$ turn until the line on the square shanks are horizontal. Turn safety valve $\frac{1}{4}$ turn to drain the boiler.
- 8.8.6 Place a cloth under the heat exchanger to catch surplus water.
- 8.8.7 Unscrew unions on both sides.
- 8.8.8 Carefully slide out heat exchanger avoid spillage of water on boiler electric's.
- 8.8.9 Reassemble in reverse order using new fibre washers on both unions.

8.9 FLUE FAN

Part No 5963

- 8.9.1 Gain general access as 8.4.
- 8.9.2 Remove room-sealed front cover plate as 8.5.2
- 8.9.3 Remove front of combustion chamber as 8.6.3
- 8.9.4 Unscrew maintenance clip securing screws and remove clip (fig. 30)
- 8.9.5 Remove 2 silicone air tubes from nozzles on inner flue bend.
- 8.9.6 Remove 3 flue hood retaining screws (fig. 30)
- 8.9.7 Carefully slide flue hood forward disconnecting electrical leads on fan in the process.
- 8.9.8 Unscrew 3 screws retaining fan to flue hood and remove fan. Transfer aluminium manifold (2 screws) to new fan.
- 8.9.9 Reassemble in reverse order, replacing centre screw first.

8.10 FLUE PRESSURE DIFFERENTIAL SWITCH

Part No 5926 Refer to fig. 30

- 8.10.1 Gain general access as 8.4.
- 8.10.2 Remove room-sealed front cover plate as 8.5.2
- 8.10.3 Remove 3 screws holding pressure differential switch cover (fig. 30) and remove cover.
- 8.10.4 Pull the 2 air tubes from nozzle on inner flue bend.

- 8.10.5 Pull off tab connectors and ease pressure switch upwards, disconnecting air pressure pipe in the process.

- 8.10.6 Reassemble in reverse order. See fig. 40 for correct fitting of electrical connections. The air pipes must be reconnected to the correct nozzles. (The upper nozzle on the pressure switch connects to the upper nozzle on the flue bend).

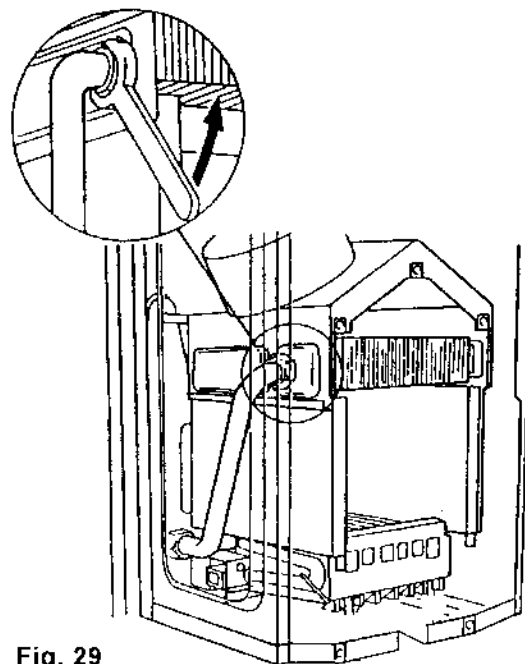

Fig. 29

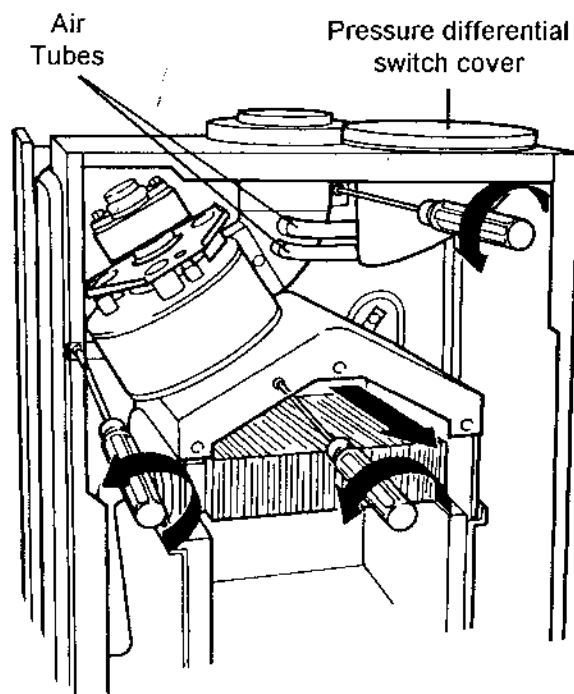

Fig. 30

8.11 COMBUSTION CHAMBER INSULATION BOARDS

- 8.11.1 Gain general access as 8.4.
- 8.11.2 Remove room-sealed front cover 8.5.2.
Remove front of combustion chamber 8.6.3
Remove main heat exchanger 8.8
- 8.11.3 To remove side combustion chamber insulation boards, gently prise upwards and pull out.
- 8.11.4 To remove rear board, gently prise upwards and pull out.
- 8.11.5 Fourth board (front) is replaced complete with combustion chamber front panel.

8.12 TO REMOVE/REPLACE GAS CONTROL VALVE OPERATOR

Refer to fig. 31 Part No. 0563

- 8.12.1 Pull off all electrical leads from operator tab connector.
- 8.12.2 Remove the two screws securing the operator to the gas valve body. (Fig.31)
- 8.12.3 Lift solenoid from stem.
- 8.12.4 Replace in reverse order.
(see fig. 40 for electrical connections).
- 8.12.5 Check burner pressures (cl. 6.7).

8.13 GAS CONTROL VALVE (COMPLETE)

Refer to fig. 31 Part No. 5438

- 8.13.1 Gain general access as 8.4. Turn off the gas supply. Pull off all electrical connections to solenoid.
- 8.13.2 Remove the solenoid (cl. 8.12.2 - 8.12.3) the solenoid can be transferred to a new valve.
- 8.13.3 Remove 4 flange securing screws at the lower end of the gas valve.
- 8.13.4 Loosen the 2 bracket fixing screws by 2 complete turns.
- 8.13.5 Undo pilot pipe to gas valve connection
- 8.13.6 Unscrew thermocouple where it connects to the rear of valve and pull black interuptor lead from captive slot.
- 8.13.7 Remove spade connector cover joining blue interuptor lead and disconnect spade ends
- 8.13.8 Undo the union above the gas control valve and withdraw valve.
- 8.13.9 Transfer the gas connecting pipe from the gas valve to the new valve using a new gasket.
- 8.13.10 Replace the gas valve assembly into the appliance in reverse order using a new gasket on the lower flange.
- 8.13.11 Tighten the 2 bracket fixing screws through the base frame.
- 8.13.12 Test all joints for gas soundness.
- 8.13.13 Check burner pressures (cl. 6.7).

Fig. 31

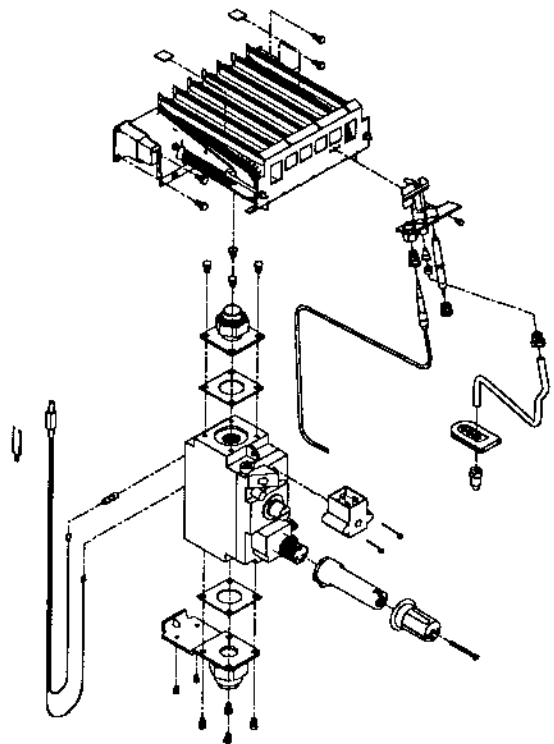

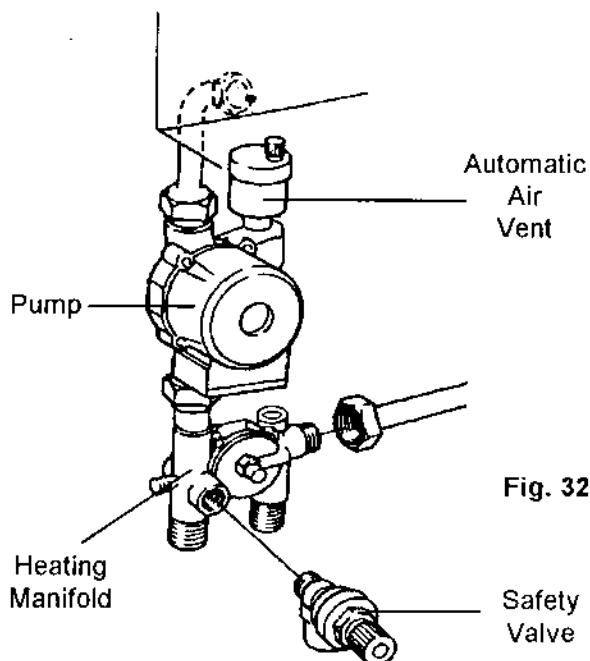

Fig. 32

8.14 PUMP

Part No. 6025 Refer fig. 32

8.14.1 Gain general access as 8.4

8.14.2 Close heating flow and return valves fig. 10a by turning $\frac{1}{4}$ turn until the line on the square shanks are horizontal. Turn safety valve $\frac{1}{4}$ turn to drain the boiler.

(A) PUMP HEAD ONLY

8.14.3 Unscrew 4 allen screws, withdraw head, disconnect electrical leads. (If replacement required, use the head from a standard 15-50 pump.)

(B) COMPLETE PUMP

8.14.4 Disconnect pipe union connection at rear left corner of combustion chamber. (Access to connection is around right hand side of gas valve using flat jaw adjustable spanner - 30mm across flats).

8.14.5 Undo lower pump union and remove pump.

8.14.6 Disconnect electrical leads from pump.

Reassemble in reverse order. Reconnect electrical leads. Brown to L, Blue to N, Yellow/green to E.

8.15 HEATING MANIFOLD

Part No 3175 Refer to fig. 33

8.15.1 Remove pump as 8.14.

8.15.2 Disconnect safety valve discharge pipe and heating valve unions.

8.15.3 Remove retaining screw (securing manifold to frame).

8.15.4 Disconnect expansion vessel pipe union, pressure gauge connection and heating flow pipe union.

8.15.5 Unscrew and remove retaining nut and remove micro switch.

8.15.6 Remove manifold

MANIFOLD ASSEMBLY

Release cover retaining screws and ease off with a screwdriver.

Refer to fig. 33 for location of components.

Replace in reverse order, ensuring that washers are replaced in all union connections.

8.16 CHECKING/REPLACING MAIN EXPANSION VESSEL

8.16.1 The expansion vessel is factory pressurised to 1 bar (14.7psi) and should be checked during servicing. Should it have lost pressure it can be repressurised in situ. Drain the boiler. Fit a suitable pump and gauge (ie car foot pump and gauge) to the nipple at the top right-hand side of the expansion vessel, and pressurise to 1 bar (14.7psi) and remove the pump.

NOTE: Access to the nipple can be improved by loosening the upper vessel retaining screws and rocking the vessel forwards.

If the vessel cannot be repressurised or if pressure loss is very frequent the expansion vessel will require changing. Alternatively, a new vessel can be fitted in the return to the appliance, and the old vessel isolated in situ.

N.B. If the boiler is installed with a clearance above of 345mm (13.5in) or more and with a side exit flue it is possible to remove the expansion vessel in situ. follow steps 8.16.9 - 8.16.10

If the clearance above is less than 345 mm (13.5in) or with a back exit flue it is not possible to remove the expansion vessel in situ, follow steps 8.16.2 - 8.16.10.

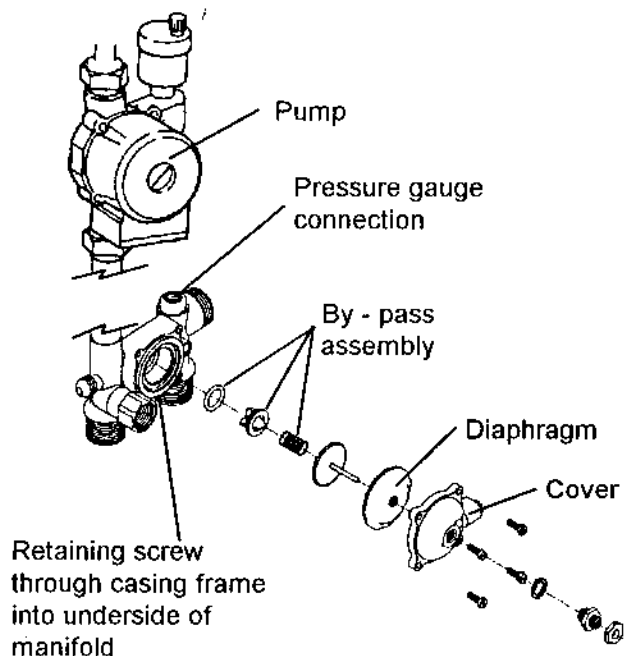

Fig. 33

- 8.16.2 Gain general access as 8.4
- 8.16.3 Close central heating flow and return valves fig. 10a by turning ¼ turn until the line on the square shanks are horizontal.
- 8.16.4 Drain appliance via safety valve by ¼ turn of knob.
- 8.16.5 Remove screws on large maintenance clips (fig. 34) and remove clips, loosen screws on the small clips and remove flue elbow.
- 8.16.6 Disconnect all pipe unions at the appliance base.
- 8.16.7 Switch OFF mains electricity and disconnect electrical connections at terminal block.
- 8.16.8 Remove lower fixings and lift appliance off upper bracket.
- 8.16.9 Remove 2 screws securing vessel at top. Disconnect expansion pipe at heating manifold, lift vessel & pipe out of appliance.(fig. 35)

8.16.10 Reassemble and remount all in reverse order.

8.17 SAFETY VALVE

- 8.17.1 Gain general access as 8.4
- 8.17.2 Close heating flow and return valves fig.10a by turning ¼ turn until the line on the square shanks are horizontal. Turn safety valve ¼ turn to drain the boiler.
- 8.17.3 Remove Heating Microswitch as 8.19.2.

- 8.17.4 Unscrew safety valve discharge pipe.
- 8.17.5 Unscrew complete valve from Heating Manifold.
- 8.17.6 Replace in reverse order.

8.18.1 PRESSURE GAUGE

- 8.18.1 Gain general access as 8.4
- 8.18.2 Close heating flow and return valves fig.10a by turning ¼ turn until the line on the square shanks are horizontal. Turn safety valve ¼ turn to drain the boiler.
- 8.18.3 Trace capillary from back of gauge to connecting point on heating manifold (fig. 33).

- 8.18.4 Unscrew union on manifold.
- 8.18.5 Squeeze plastic locking lugs behind fascia and press gauge from aperture.
- 8.18.6 Replace in reverse order.

8.19 REMOVAL OF ELECTRICAL COMPONENTS

8.19.1 Ensure electricity is switched off at main isolator. Gain general access as 8.4

8.19.2 FLOW MICRO SWITCH
Part No 4302 Refer to fig. 33

- 8.19.3 Hold switch and unscrew retaining nut.
- 8.19.4 Remove switch and remove cover.
- 8.19.5 Pull off electrical tab connections.

8.19.6 HIGH LIMIT THERMOSTAT
Part No. 6614

- 8.19.7 Gain general access as 8.4
- 8.19.8 Loosen thermocouple where it connects to the rear of gas valve and remove black interutor lead from captive slot.
- 8.19.9 Remove spade connector cover joining blue interuptor lead and disconnect spade ends.
- 8.19.10 Trace wires to sensor in capilliary tube, remove retaining clip from the flow tube and withdraw sensor probe.
- 8.19.11 Reassemble in reverse order ensuring the sensor is fully located in the pocket.

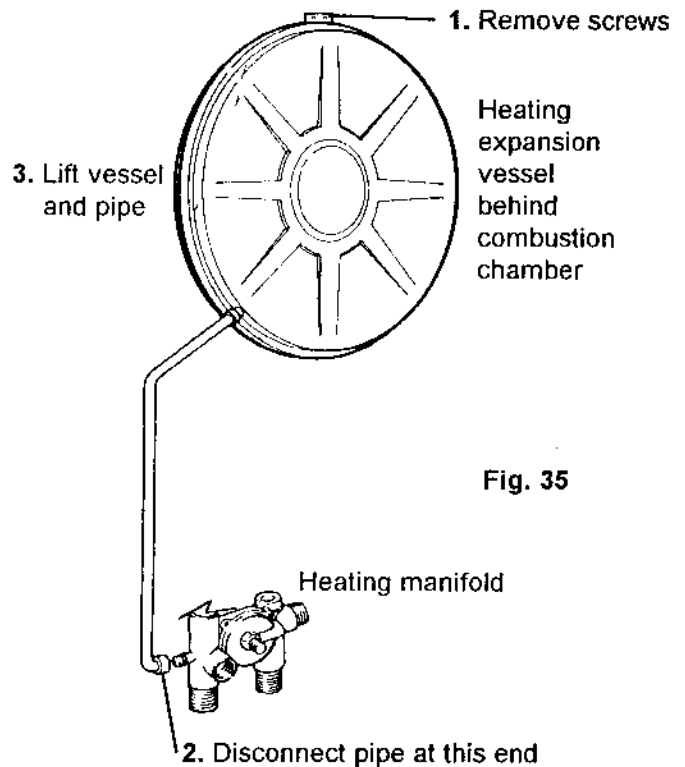
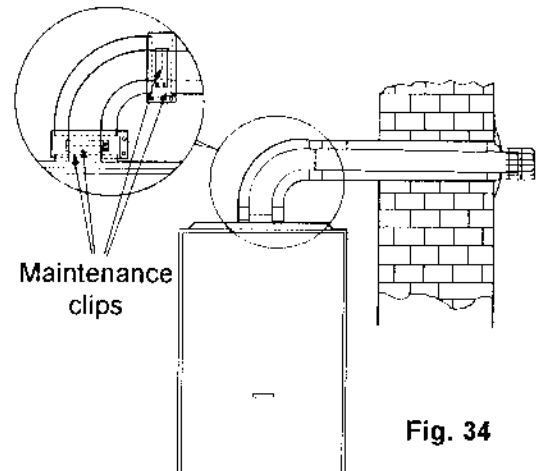

8.19.12 SAFETY THERMOSTAT
Part number 5441 Refer to fig. 36.

8.19.13 Pull off two electrical tab connectors on safety thermostat (marked with a yellow spot).

8.19.14 Ease off thermostat retaining clip.

8.19.15 Reassemble in reverse order.

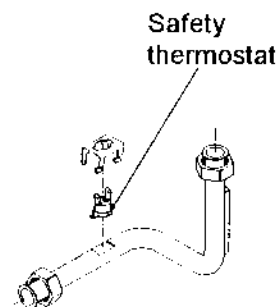

8.19.16 HEATING THERMOSTAT
Part No 3267

Fig.36

8.19.17 Remove room-sealed front cover 8.5.2

8.19.18 Trace capillary tube to sensor, and remove the sensor from it's pocket.

8.19.19 Pull electrical tabs off back of thermostat.

8.19.20 Remove the earth lead from thermostat.

8.19.21 Pull knob off front facia panel revealing 2 retaining screws.

8.19.22 Remove screws to release thermostat.

8.19.23 Reassemble in reverse order ensure the wires connect to the correct terminals (p1 & 1). Terminal 2 is a spare terminal.

8.19.24 Replace earth wire onto thermostat.

8.19.25 PRINTED CIRCUIT BOARD
Part No. 8166

8.19.26 Ref 8.4

8.19.27 Remove the 2 plugs from p.c.b.

8.19.28 Gently squeeze the four retaining clips and ease the circuit board up and out.

8.19.29 Reassemble in reverse order.

8.19.30 MODE SELECTOR SWITCH
Part No. 5591

8.19.31 Pull knob off front facia panel revealing 2 retaining screws

8.19.32 Remove screws to release switch.

8.19.33 Pull electrical tabs off back of switch.

8.19.34 Reassemble in reverse order.

8.19.35 FAN SLOW SPEED RESISTOR

8.19.36 Unplug inline connector below fan resistor.

8.19.37 Remove two screws securing resistor.

8.19.38 Reassemble in reverse order.

8.20 END OF SERVICING

Run through the general commissioning as described in Section 6 as far as they apply.

Refit casings and clean up.

- 9.1** On completion of any service/fault finding task which has required the breaking and remaking of electrical connections the checks Earth Continuity, polarity and Resistance to Earth must be repeated.

The following flow diagrams suggest the logical sequence of steps for fault finding.

They are not exhaustive but cover all that can reasonably be carried out on site by the installer or service engineer.

Acquaintance with the functional sequence will prove helpful for some, and this is included for reference. As further help, the role of each part is briefly described.

Also included in this section are wiring diagrams and schematics to assist in fault location and servicing as described in the text.

9.2 SEQUENCE OF FUNCTIONS

When following this sequence, refer to figs. 38 & 39. It is assumed that the mode selector switch and gas supply are ON and the pilot flame is lit.

9.2.1 AT REST

No call for heat. current flows via the normally closed contacts of R1, through the 560Ω resistor then through the normally closed contacts of the boiler flow switch to the fan which runs at slow speed

N.B. If the electricity supply is switched off or fails the fan will cease to operate and there may be insufficient air to maintain the pilot. A relighting of the pilot would be necessary.

9.2.2 DEMAND FOR HEAT

With all the controls calling for heat the pump will start changing over the boiler flow switch, at the same time a supply through the boiler thermostat will energise terminal 3 (common) and in turn 1 (normally closed) on the pressure differential switch.

The relay is energised causing the contact of R1 to be made. The fan will start and the pressure differential switch will change over energising the gas valve. The gas will flow and be lit by the permanent pilot.

The boiler will produce heat while there is a demand, or until the boiler thermostat is satisfied and P1-1 breaks.

The boiler circuitry will go to rest, but the pump will remain running to circulate water around the circuit.

If the supply to P1 is broken (e.g. by a room thermostat) both the boiler and pump are switched off.

FAULT FINDING STEP ONE CHECK GAS CONTROL PILOT BURNER FLAME SUPERVISING SYSTEM

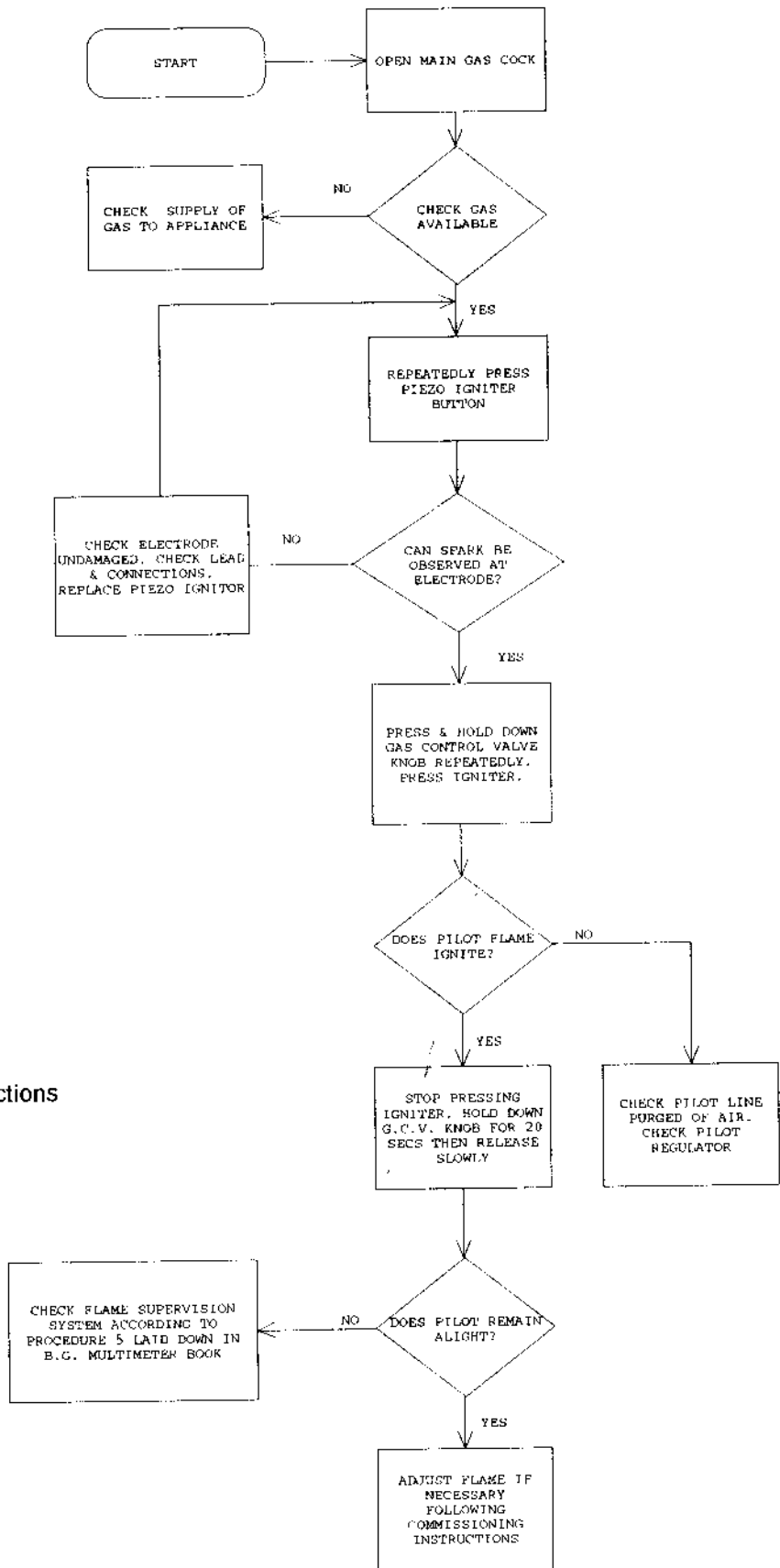

NOTE See commissioning instructions

FAULT FINDING STEP TWO CHECK ELECTRICAL SUPPLIES, SWITCHES & CONNECTIONS

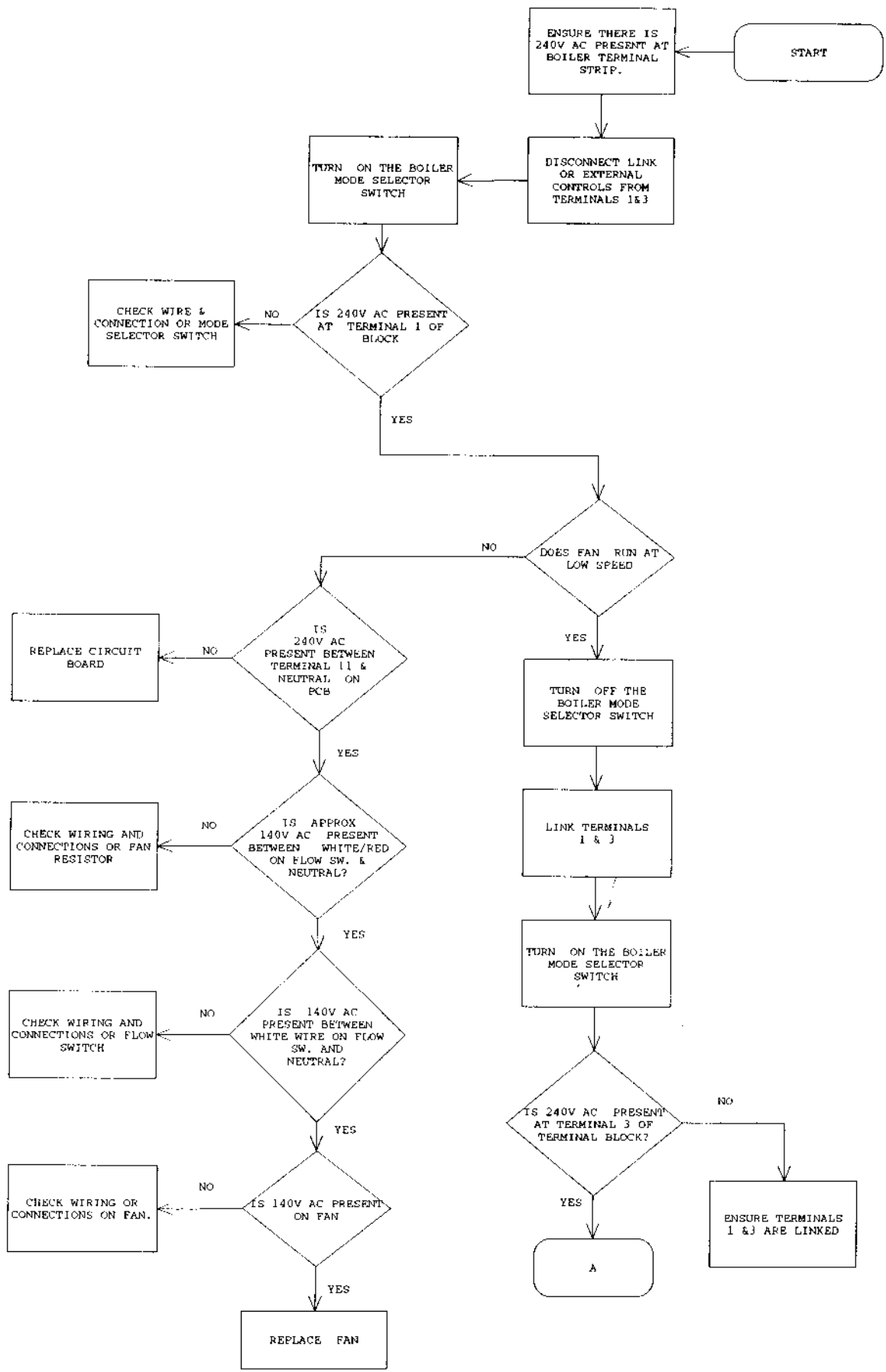

FAULT FINDING STEP THREE CHECKING INTERNAL ELECTRICAL CIRCUITS

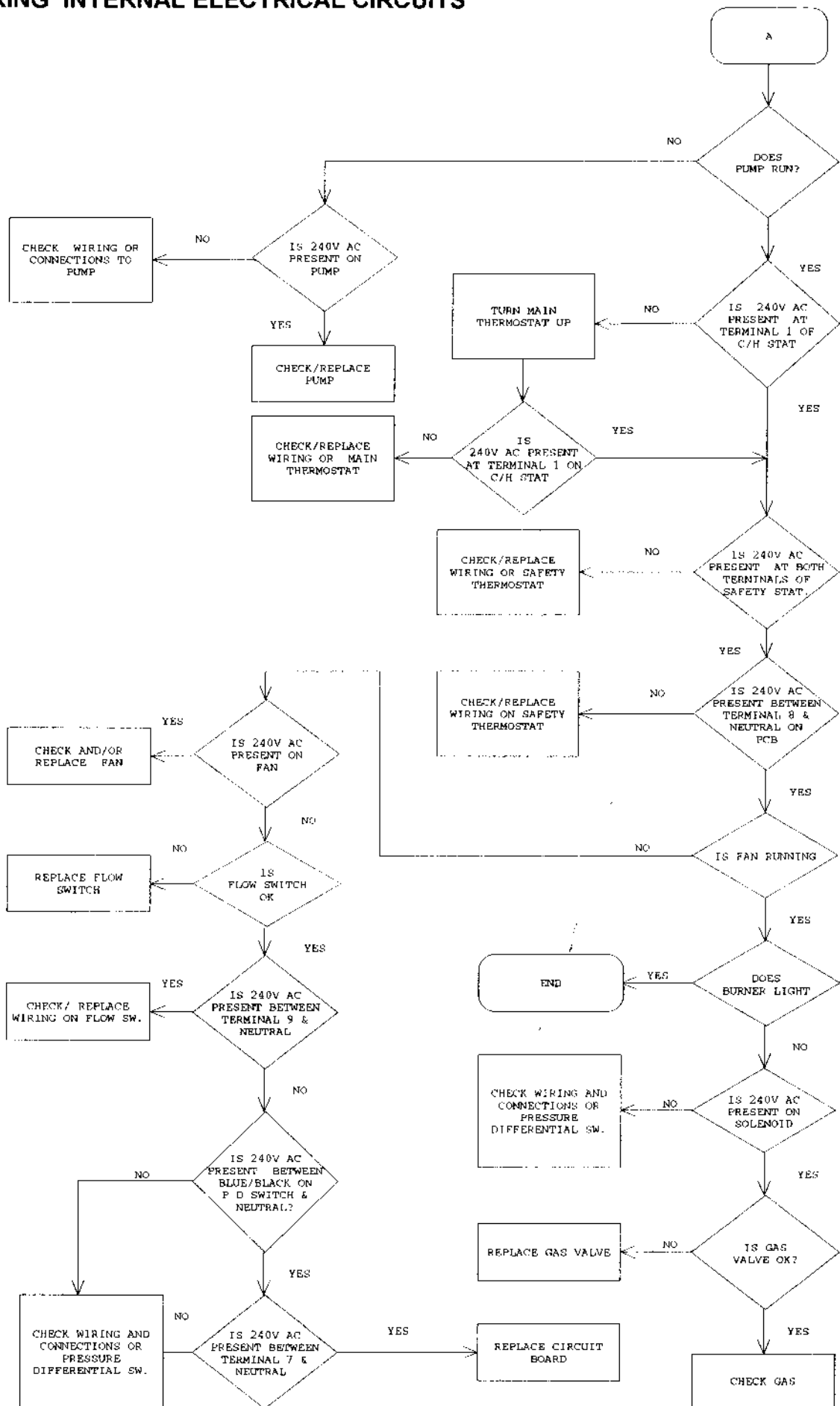

Instructions for:

- (A) Fitting Vokera 24 hour time switch (part no. 032 G.C. no. 301 110), fitting Vokera digital 7 day time switch (part no.005 G.C. no. 301 109) and Vokera 2 channel programmer (7 Day) (part no. 081 G.C. no. 370 395).**
- (B) Wiring to external time switches, room thermostats and frost thermostats.**
- (C) Wiring to 'Y' plan or 'S' plan installations.**

A. INSTALLATION OF VOKERA TIME SWITCHES (24 HOUR AND 7 DAY).

Remove the clock aperture blanking plate (1) (fig. 1) by squeezing the four lugs on the rear of the plate together and push the plate out.

Push out the centre of the blanking plate to leave a circular hole to which the clocks can be fitted.

Remove the clock from its box.

Wire the clock as shown in fig. 4.

Insert the clock into the aperture from the back of the control panel. Push the mounting bezel through the front panel and secure to the clock using the four screws provided.

Connect the other ends of the wires to the main controls terminal block as detailed below.

Red/White: Cut off the spade connector, strip the end of the wire and connect to the output terminal block marked L.

Blue: Connect to the output terminal block marked N.

Red/Black: Cut off the spade connector, strip the end of the wire and connect to the controls terminal block marked 1.

FOR INTERNAL CLOCK ONLY

White: Connect to the controls terminal block marked 3, remove the link wire connected between terminals 1-3.

FOR INTERNAL CLOCK AND ROOM STAT

White: Connect to the controls terminal block marked 2, remove the link wire between terminals 1-3 and connect the room thermostat between terminals 2-3.

ROOM THERMOSTAT ONLY

Remove the loop between terminals 1-3 and connect the room thermostat as fig. 3

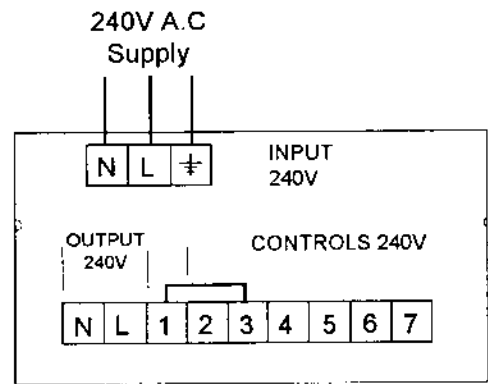

Fig. 2

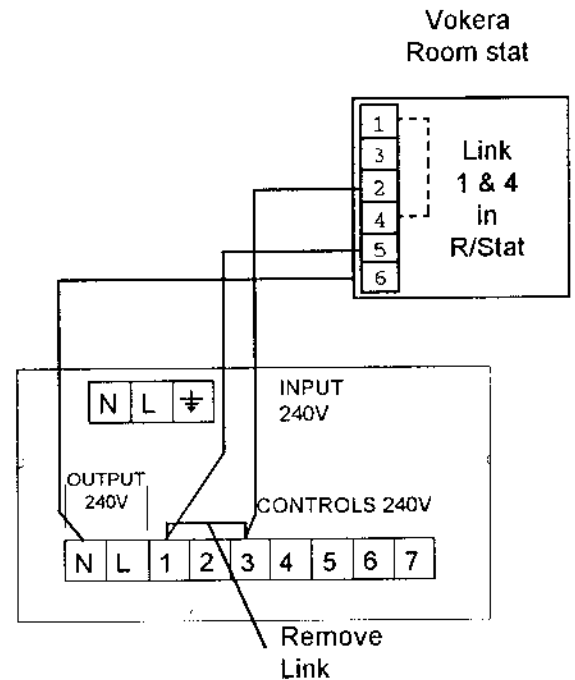

Fig. 3

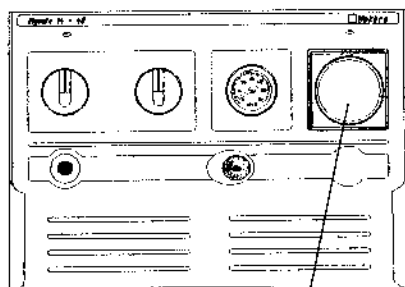

Fig. 1

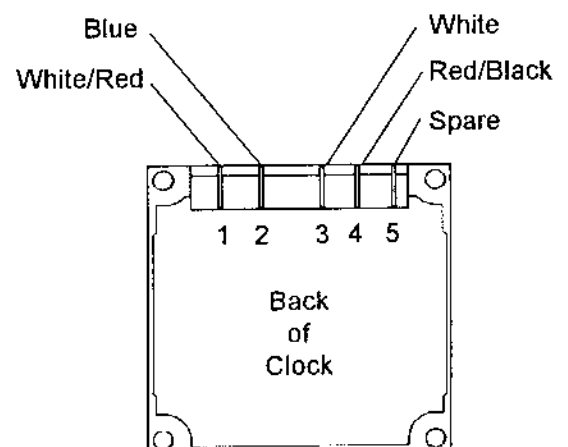

Fig. 4

INSTALLATION OF VOKERA 2 CHANNEL PROGRAMMER (7 Day).

Remove the clock aperture blanking plate (1) Fig. 1. by squeezing the four lugs on the rear of the plate together and push the plate out.

Remove the clock from its box.

Wire the clock as shown in fig. 5.

Insert the clock into the aperture from the front of the control panel fig. 6.

Connect the other ends of the wires to the main controls terminal block as detailed below. See fig. 5.

Brown: Connect to terminal marked L on the controls terminal block.

Blue: Connect to terminal marked N on the controls terminal block.

Red: Connect to terminal marked 4 on the controls terminal block.

Pink: Connect to terminal marked 5 on the controls terminal block.

Grey: Connect to terminal marked 6 on the controls terminal block.

Purple: Connect to terminal marked 7 on the controls terminal block.

Remove the loop between terminals 1 & 3 on the controls terminal block. See section 10 (C) for 'S' & 'Y' plan wiring details.

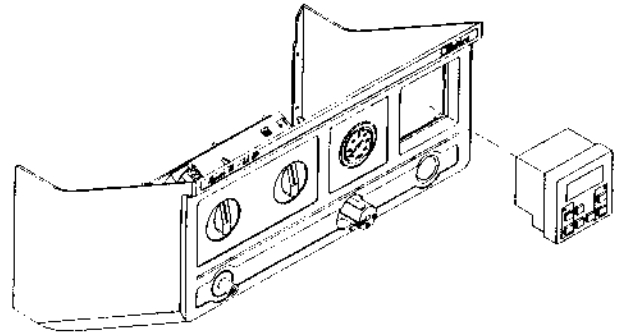

Fig. 6

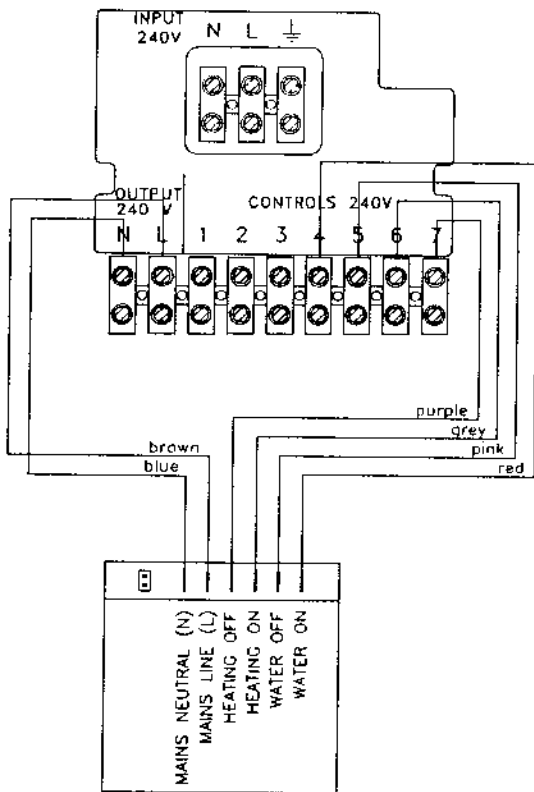
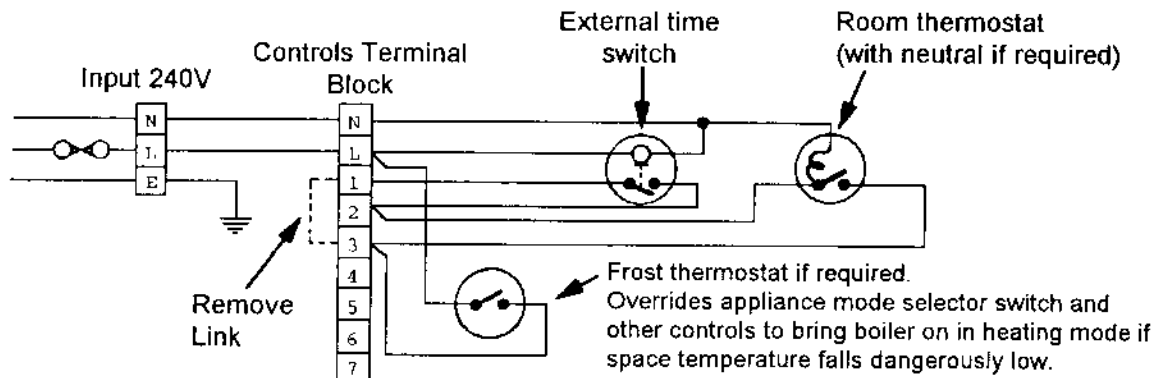
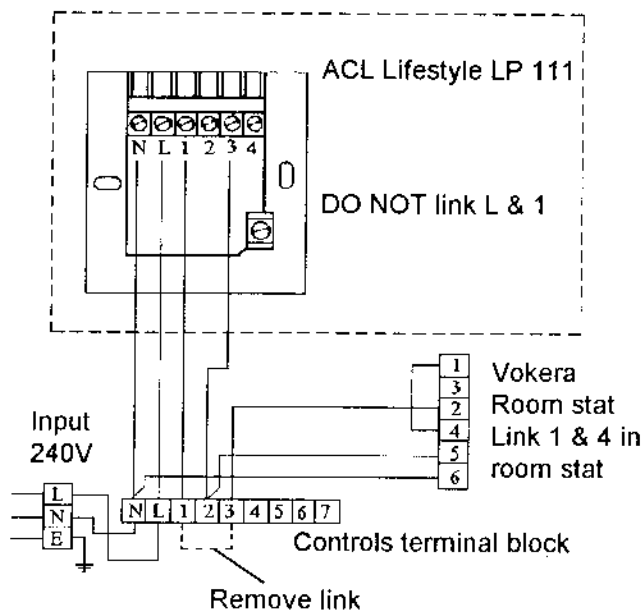

Fig. 5

B: Wiring to External Time Switches and Thermostats.
(i) General Schematic Diagram.



(ii) Time switch and Vokera room thermostat



(iii) Randall time switch and Vokera room thermostat

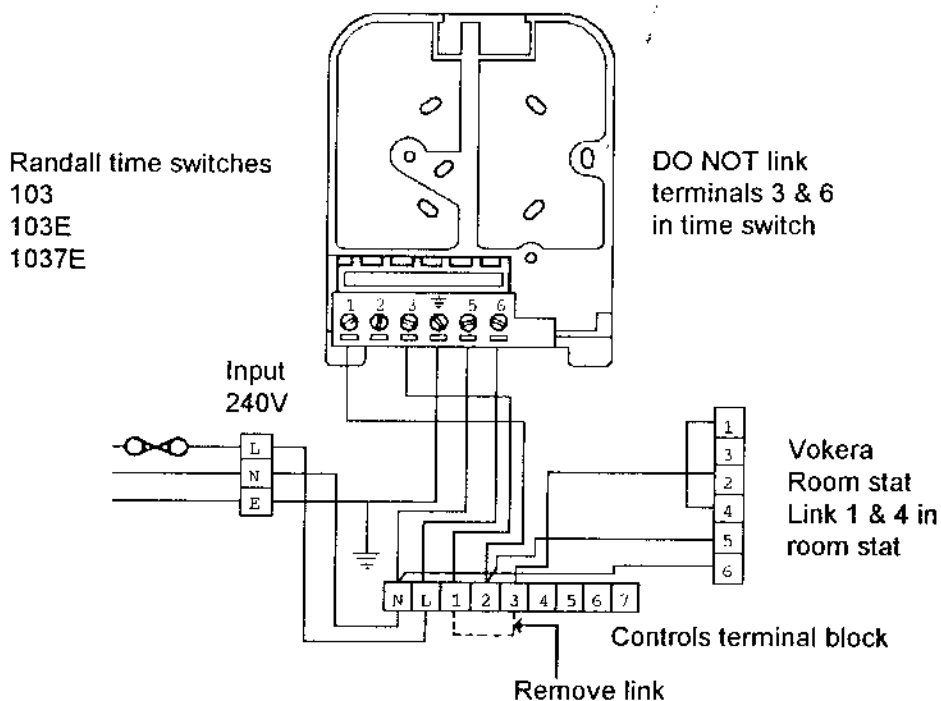

(C) Wiring to 'Y' & 'S' Plan Installations using the Vokera 2 channel programmer.

(i) 'Y' Plan

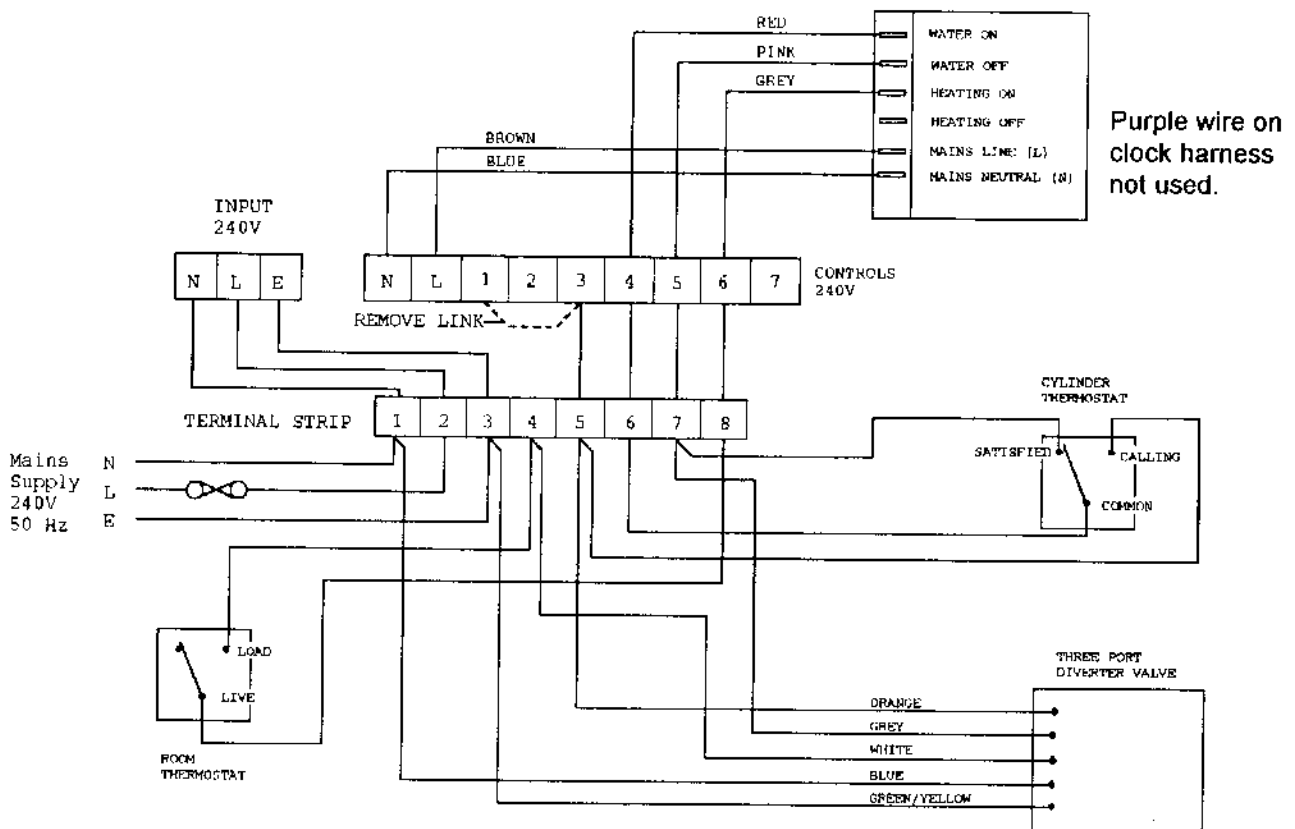

(ii) 'S' Plan

Pink and purple wires on clock harness not used with sprung return motorised valves. Use only if power on and power off motorised valves are used (not shown).

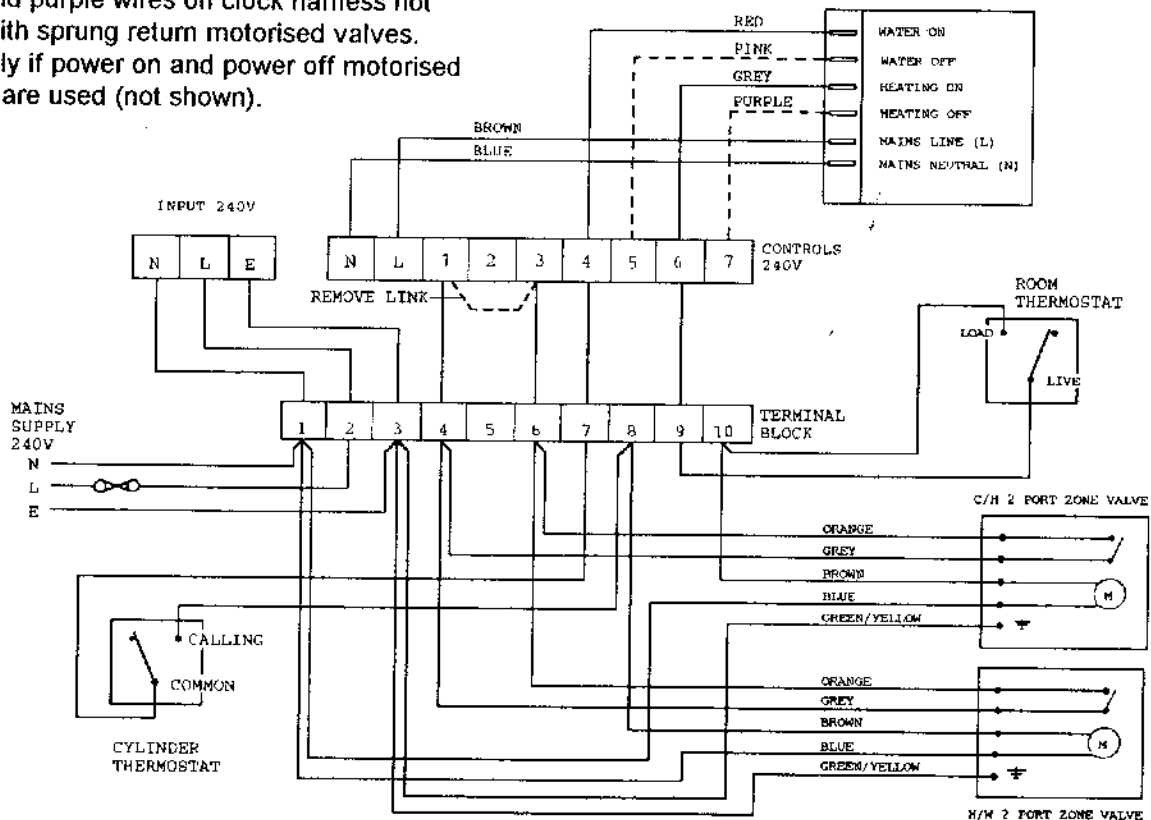

Wiring to 'Y' and 'S' plan installations using an external programmer

(i) Y Plan

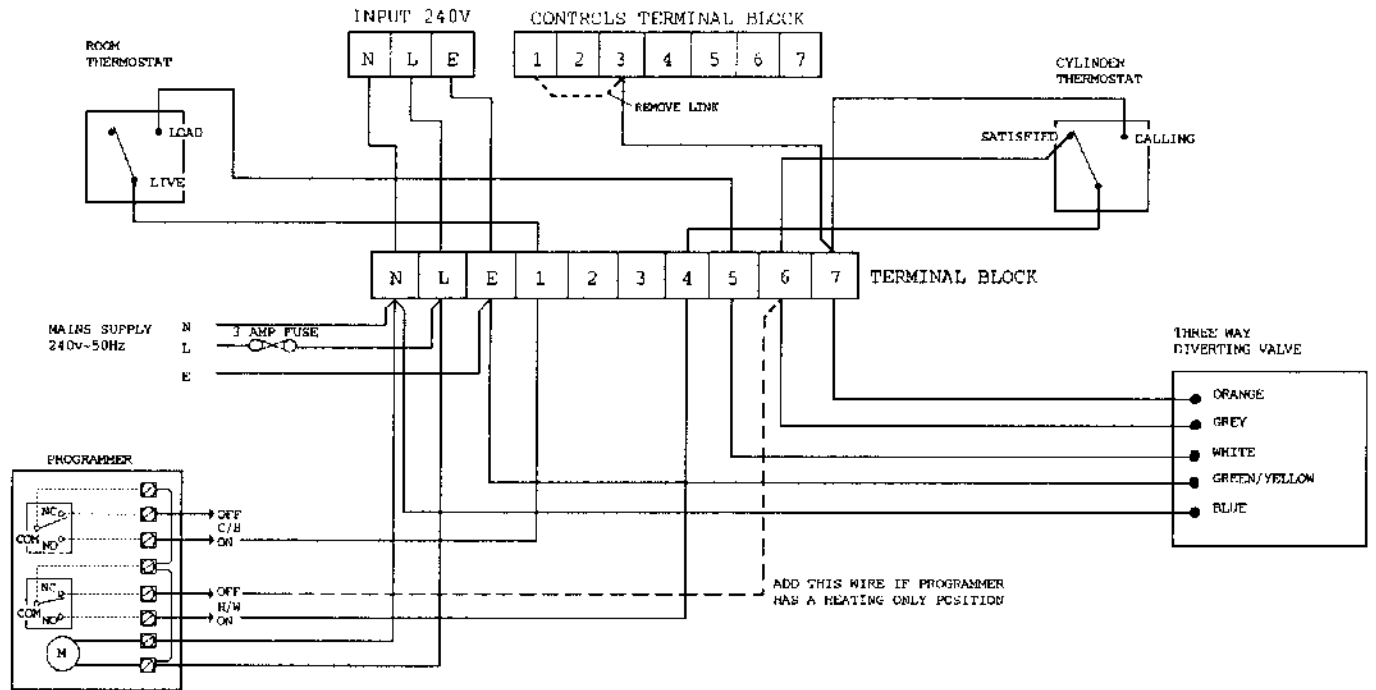

(ii) S Plan

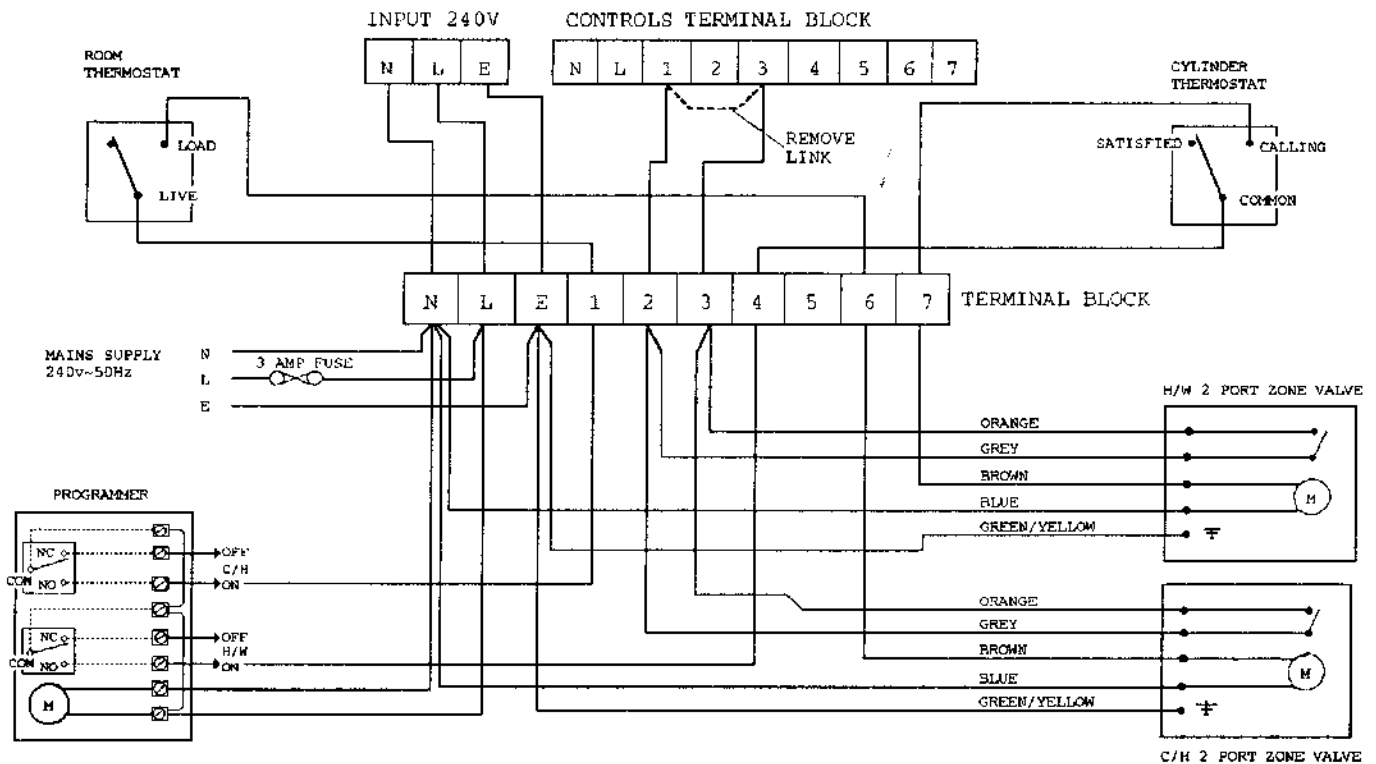

EXPLODED DIAGRAMS Fig. 37

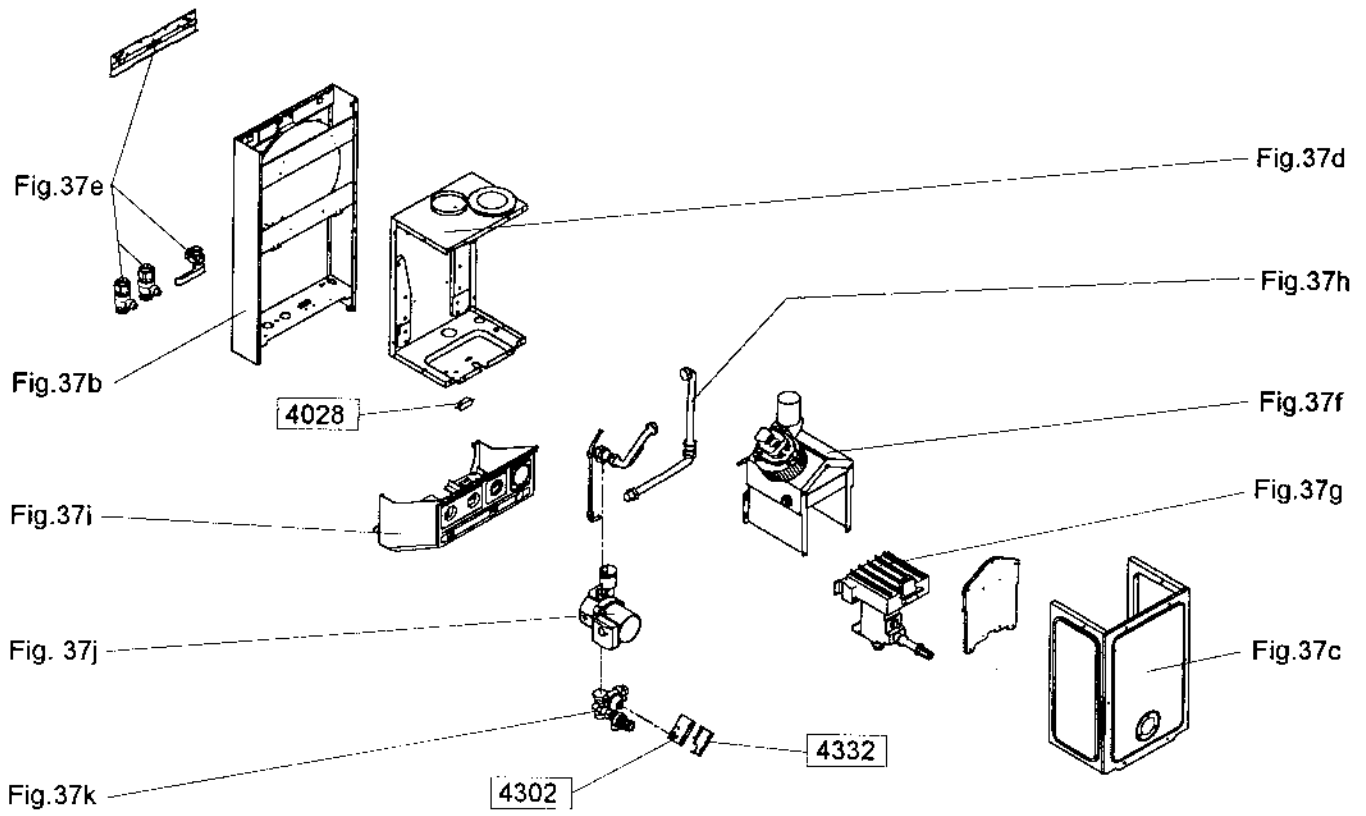

Fig. a

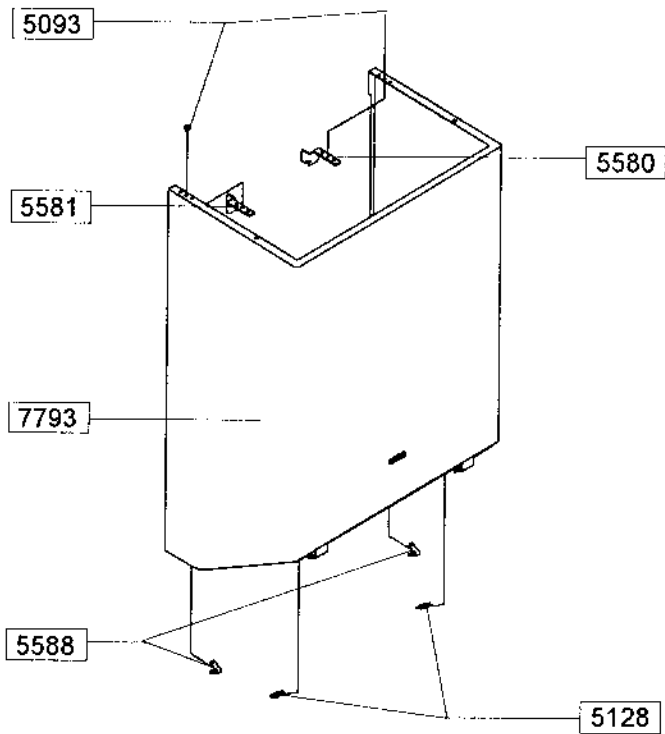

Fig. b

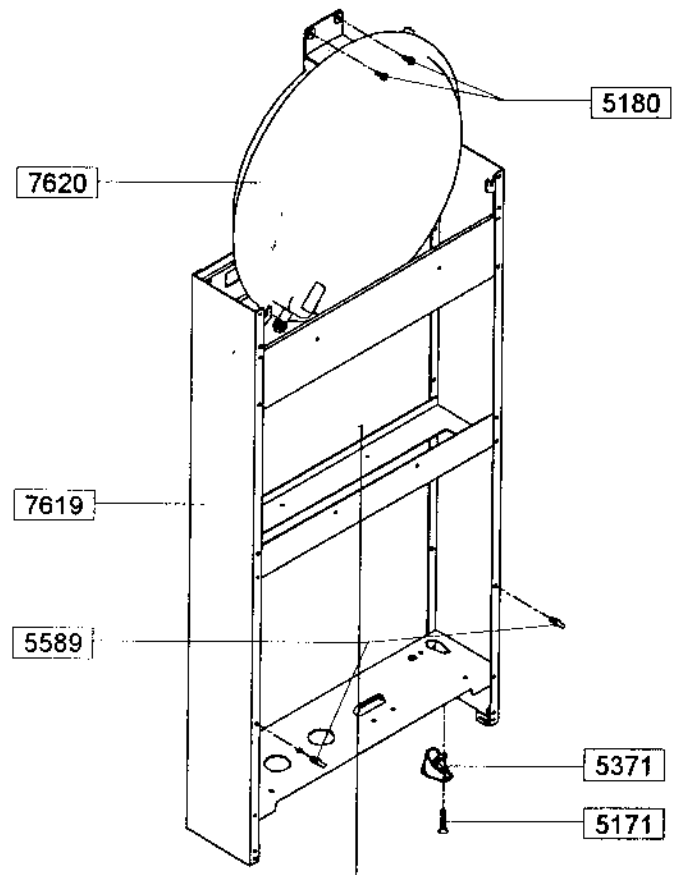

Fig. c

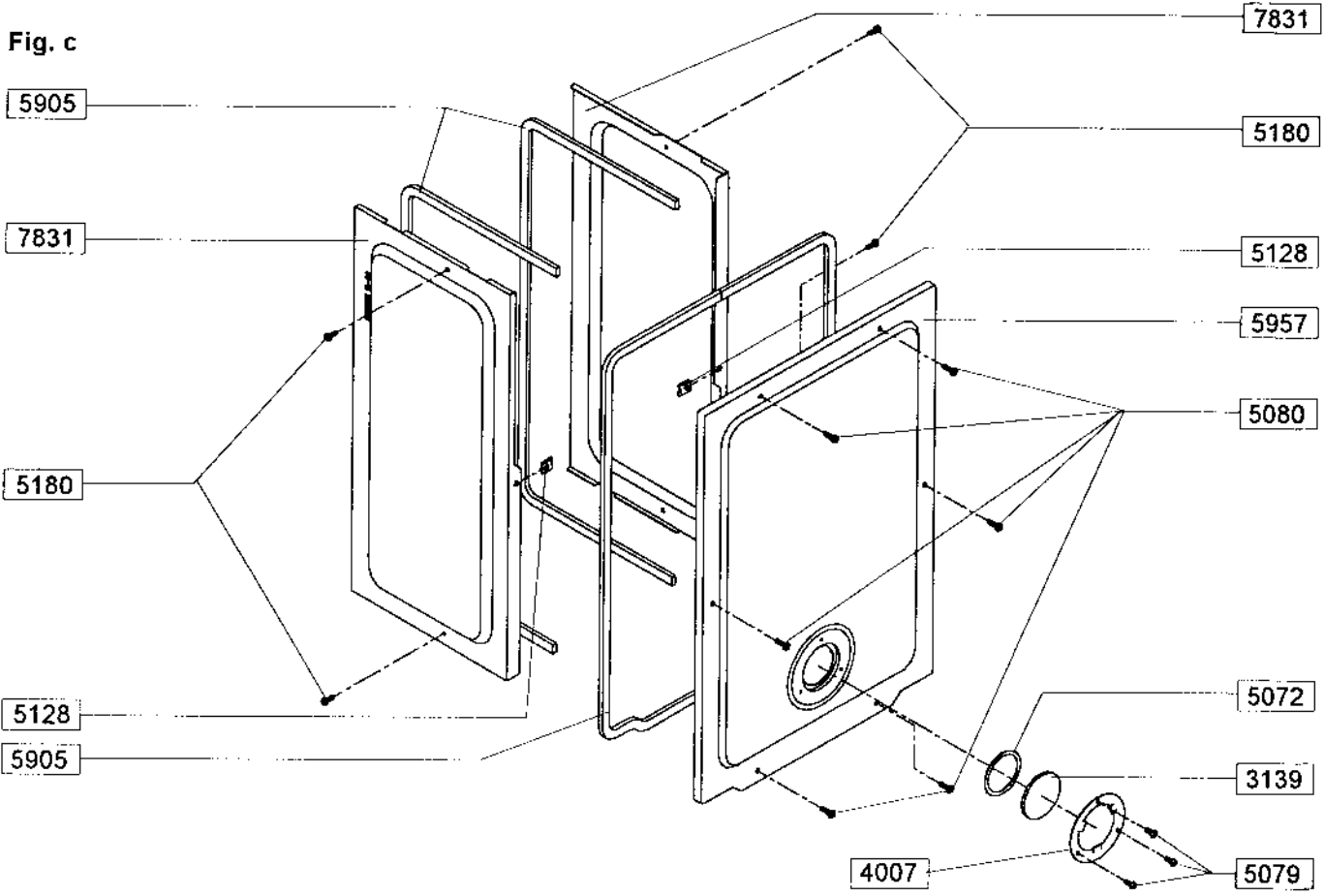

Fig. d

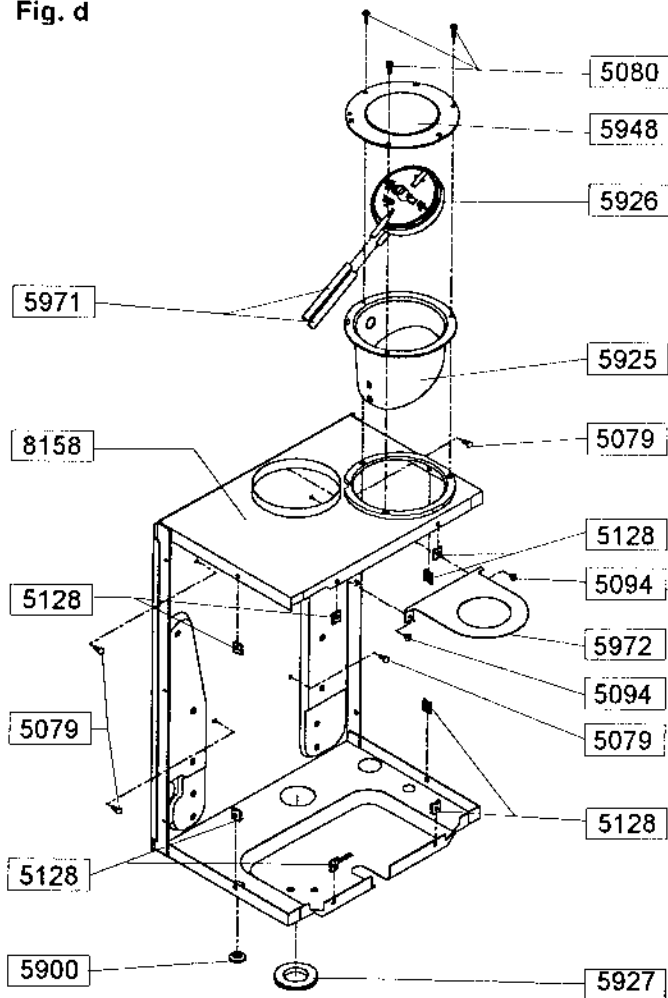
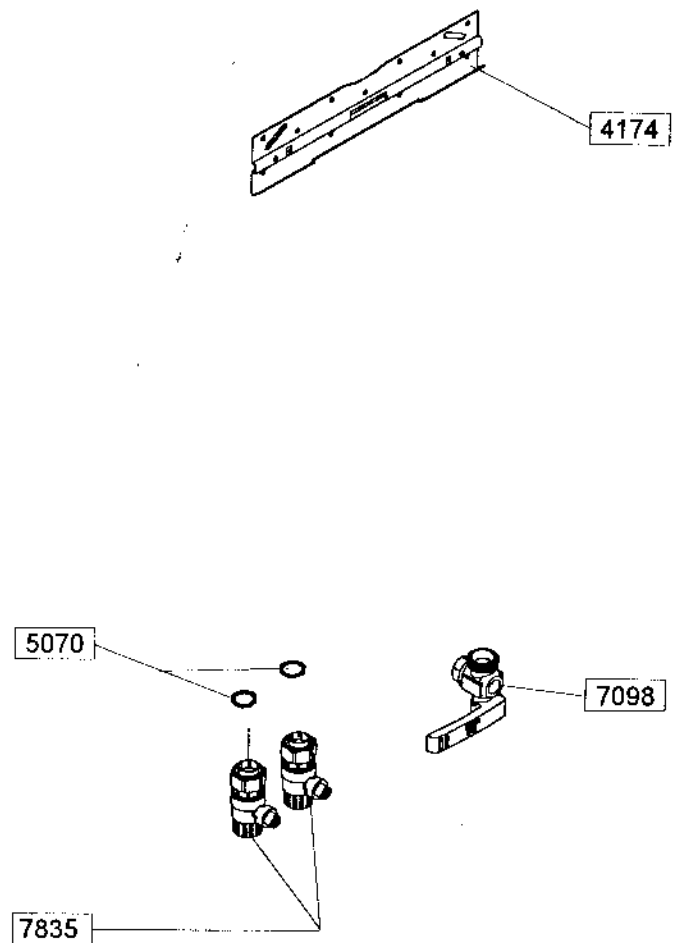

Fig. e



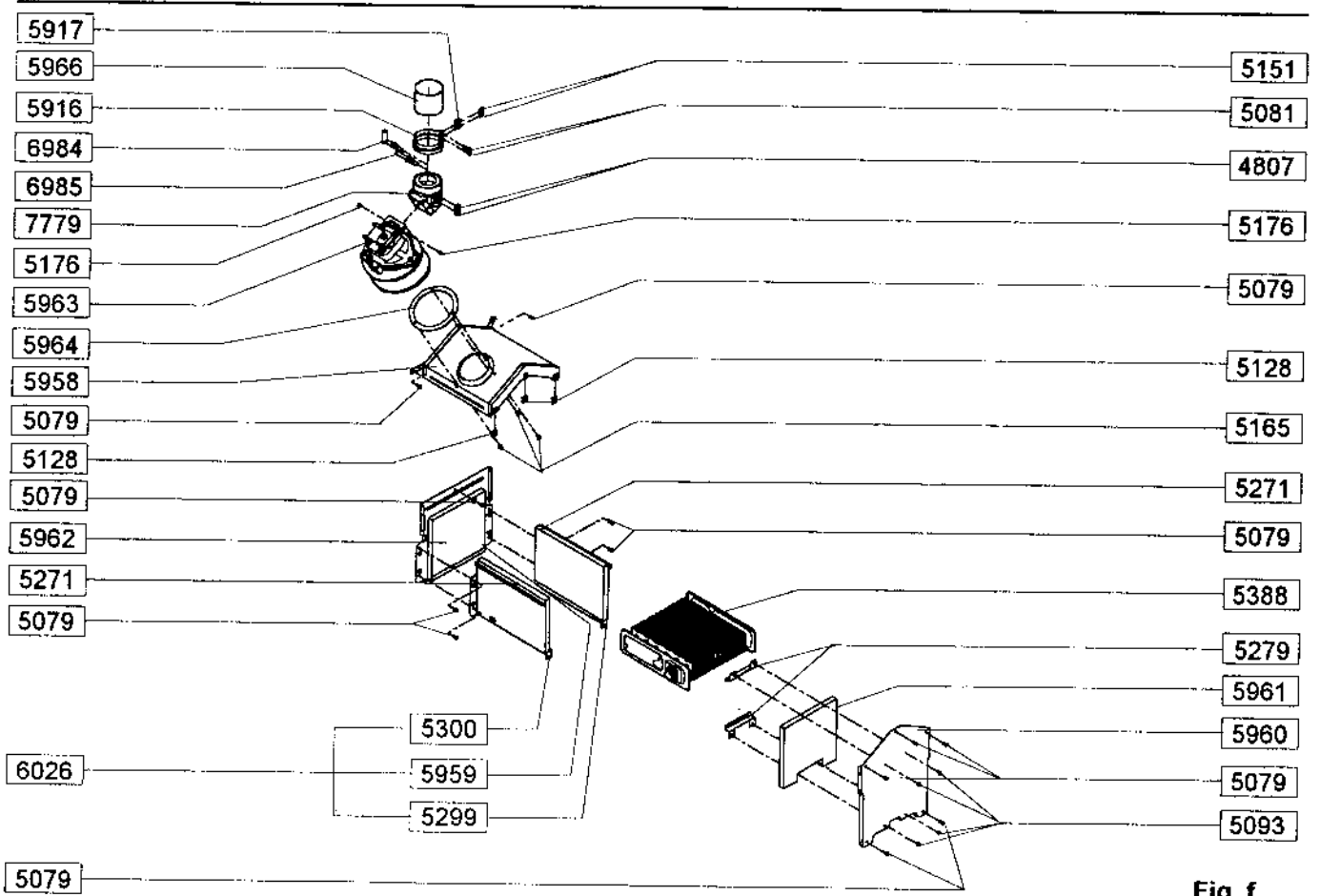

Fig. f

Fig. g

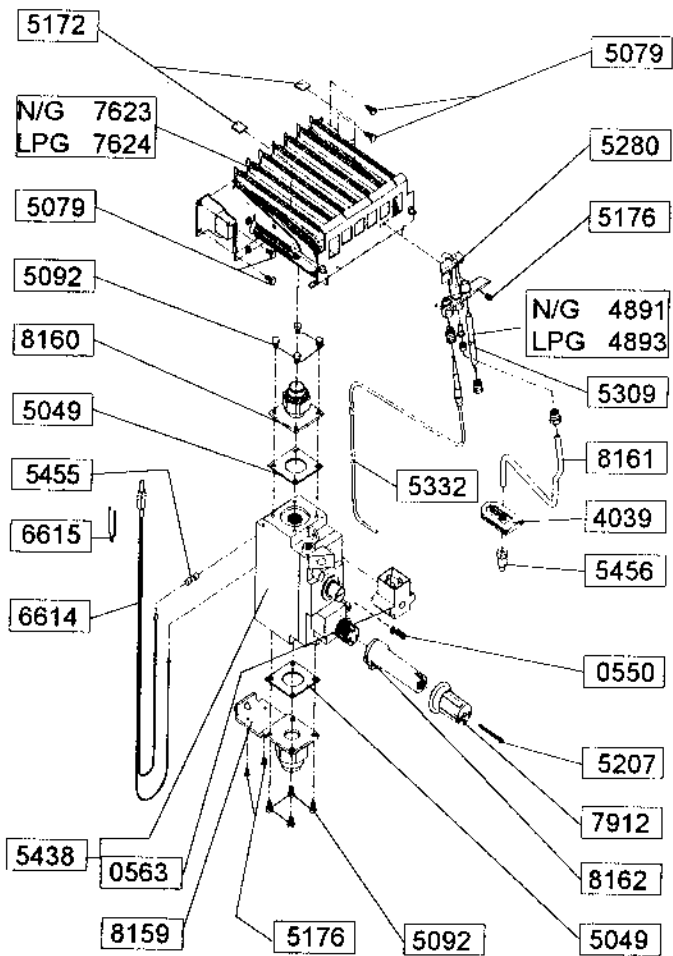

Fig. h

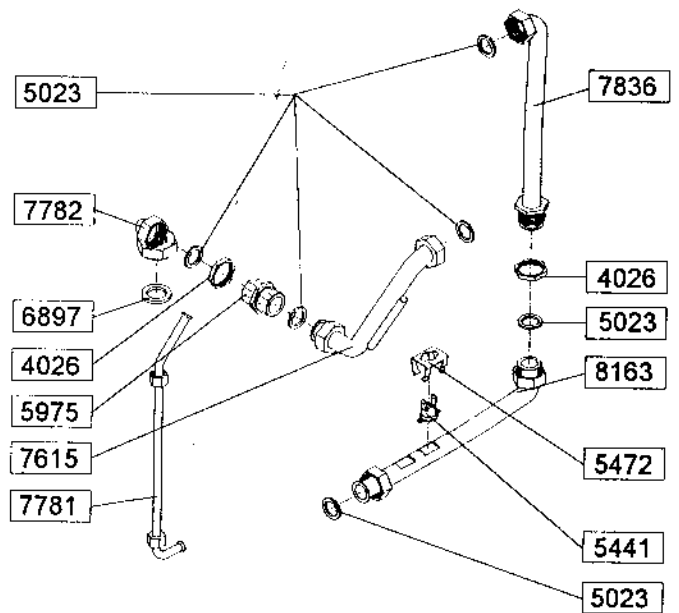

Fig. i

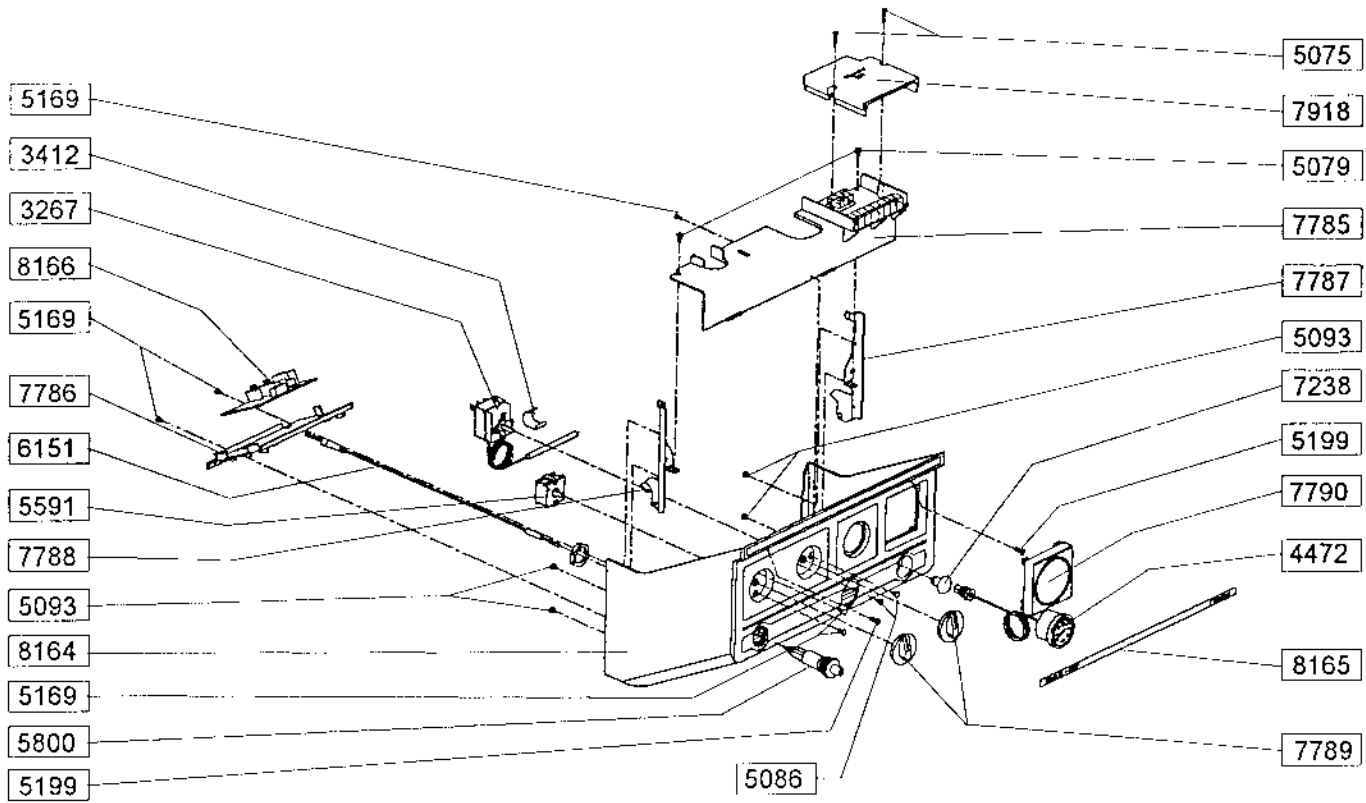

Fig. j

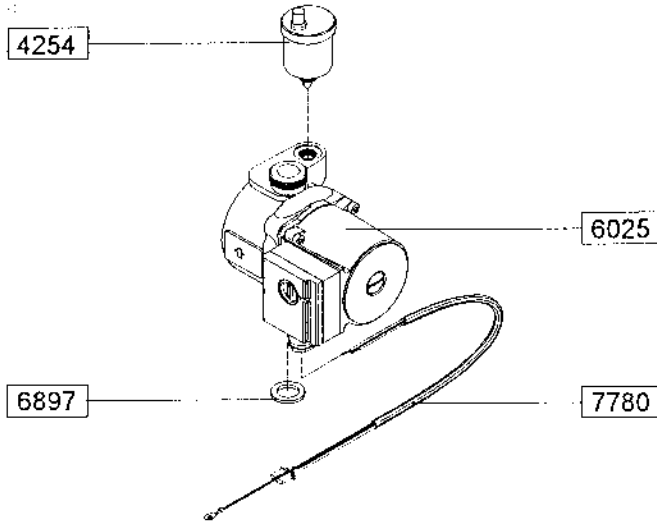
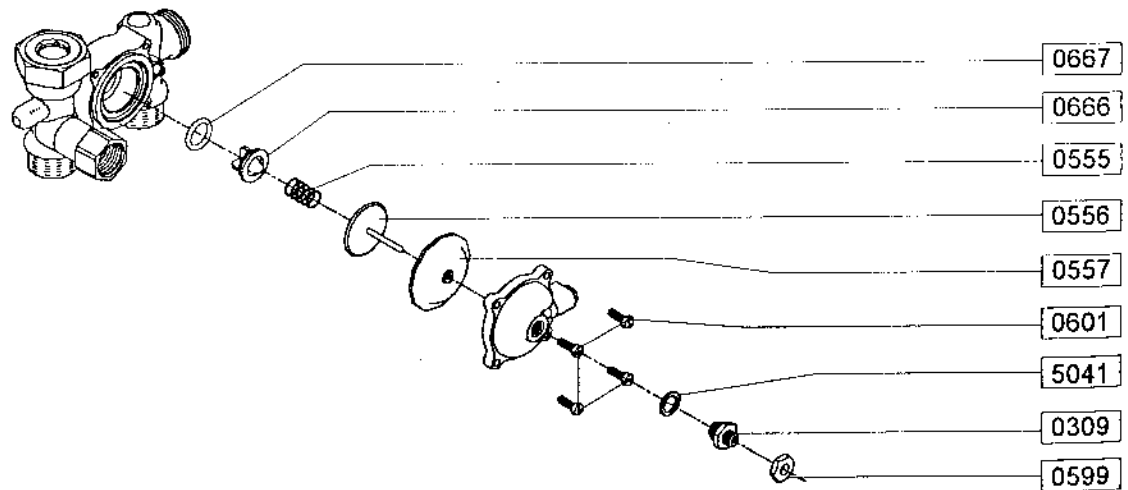
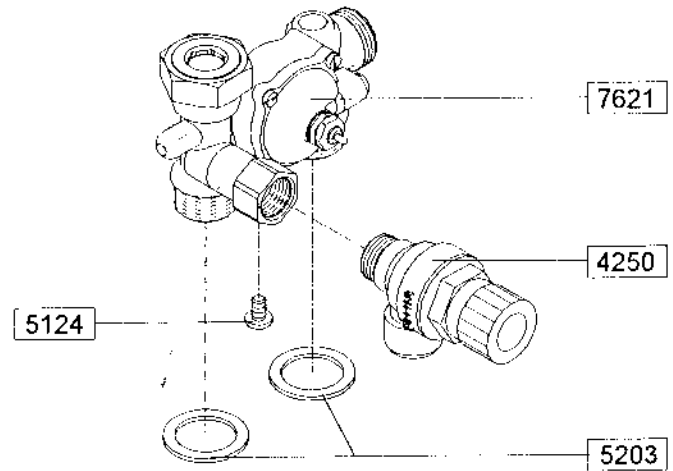

Fig. k



SHORT SPARE PARTS LIST

Code	G.C. No.	Description
0557	333 941	Flow Switch Diaphragm
3267	370 345	Boiler Thermostat
4250	333 772	Safety Valve
4254	333 722	Automatic Air Vent
4302	333 773	Single Microswitch
4472	333 776	Pressure Gauge
5280	301 112	Pilot Assembly
5309	301 083	Spark Electrode
5388	370 315	Main Heat Exchanger
5441	301 027	Safety Thermostat
5591	370 408	Mode Selector Switch
5800	301 090	Piezo Ignitor
5926	301 063	Pressure Differential Switch
5963	397 760	Fan
6025	379 297	Pump
7623	379 614	Main Burner

FUNCTIONAL FLOW DIAGRAM

Fig.38

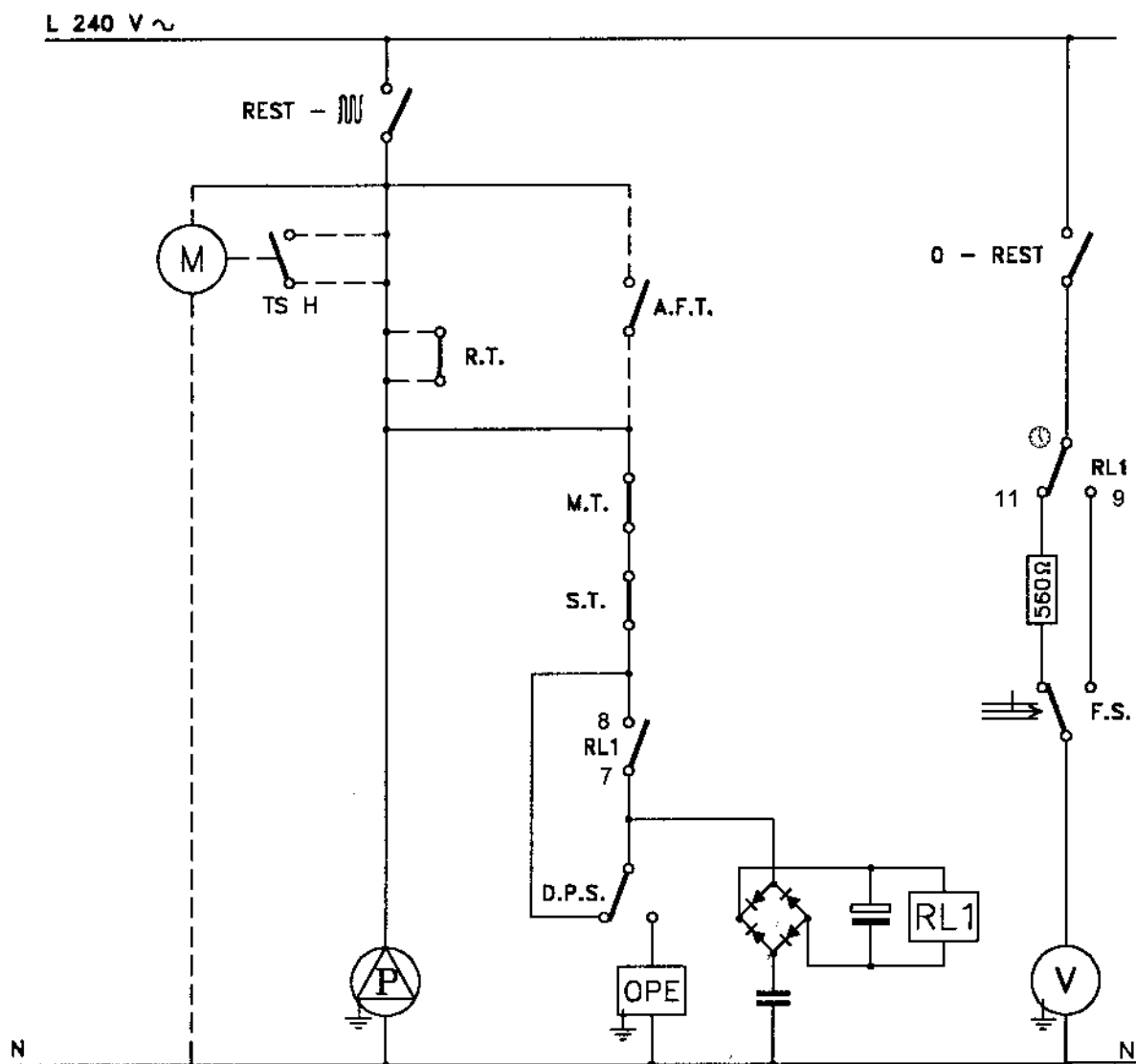

LEGEND

- | | |
|----------|--------------------------------|
| TS H | Time Switch |
| M | Clock Motor |
| R.T. | Room Thermostat |
| P | Pump |
| A.F.T. | Frost Thermostat |
| M.T. | Main Thermostat |
| S.T. | Safety Thermostat |
| RL1 | Relay |
| D.P.S. | Pressure Differential Switch |
| OPE | Solenoid |
| V | Fan |
| F.S. | Flow Switch |
| 7,8,9,11 | Relay Connection Points to PCB |

GENERAL LAYOUT

Fig. 39

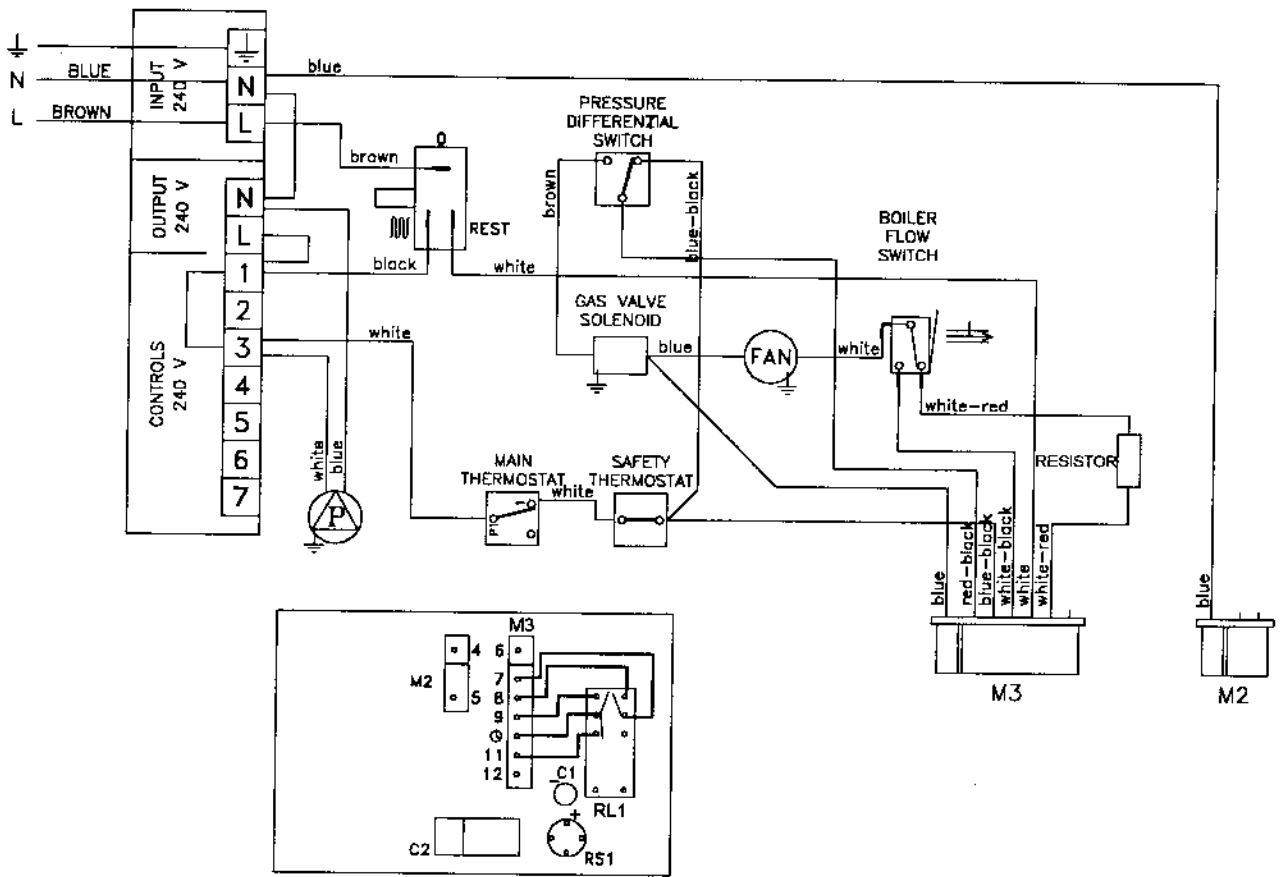

ILLUSTRATED WIRING DIAGRAM

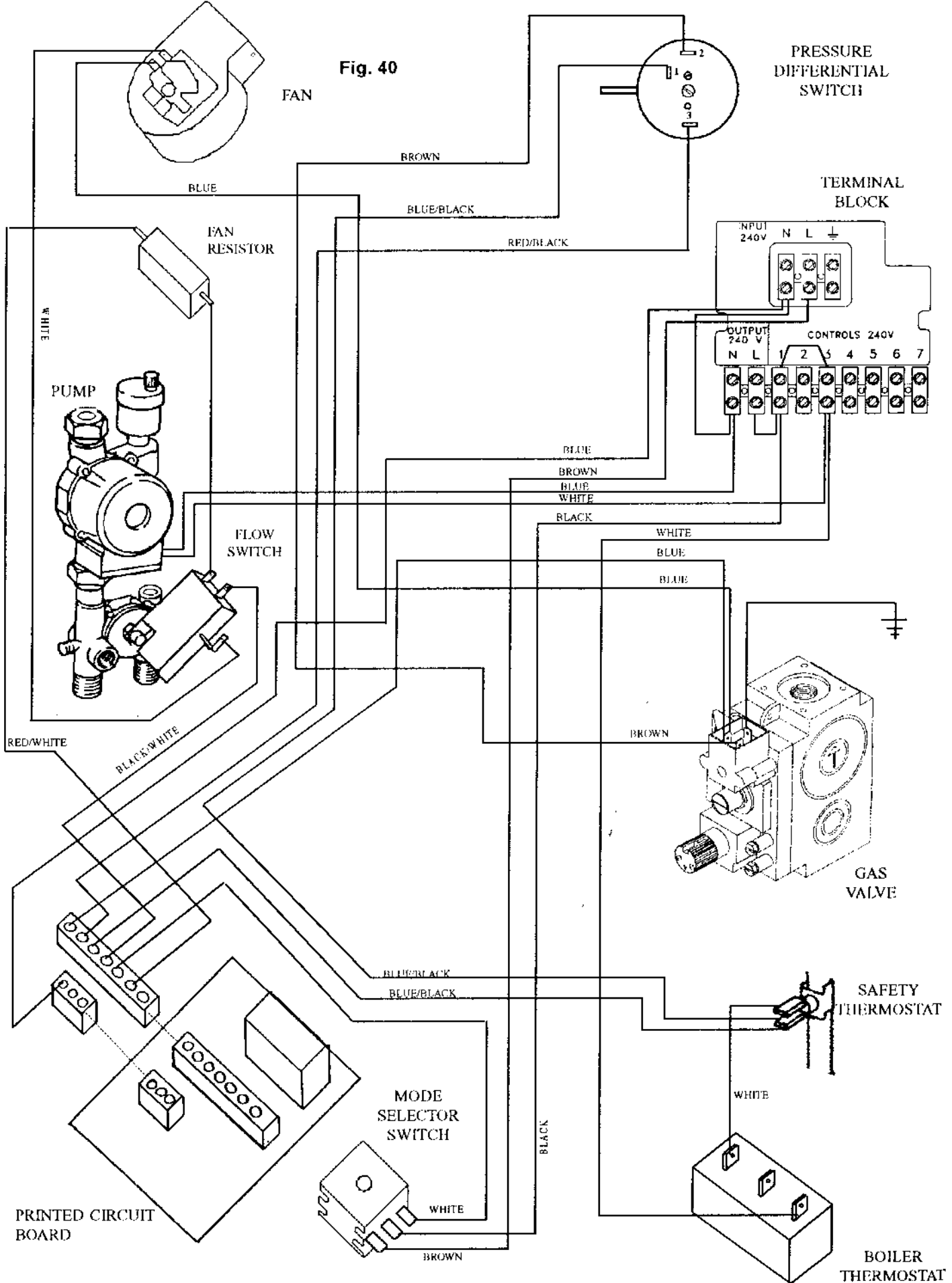

PRELIMINARY ELECTRICAL SYSTEM CHECKS

A. EARTH CONTINUITY CHECK - appliance must be electrically disconnected - meter set on Ω (ohms) x 1 scale and adjust zero if necessary.

a) Test leads from any appliance earth point to earth pin on plug - resistance should be less than 0.1 Ω (ohm).

If the resistance is greater than 0.1 Ω (ohm) check all earth wires for continuity and all contacts clean and tight.

If resistance of earth is still greater than 0.1 Ω (ohm) then this should be reported to your supervisor.

B. SHORT CIRCUIT CHECK - appliance electrically disconnected, all switches ON (including stats) -

a) meter set on Ω (ohms) x 1 scale.

Test leads from L to N in appliance terminal strip/block - if meter reads 0 then there is a short circuit.

b) meter set on Ω (ohms) x 100 scale

Repeat test with leads from L to E. If meter reads less than ∞ (infinity) there is a fault.

NOTE - Should it be found that the fuse has failed but no fault is indicated - a detailed continuity check (i.e. by disconnecting and checking each component) is required to trace the faulty component. It is possible that a fault could occur as a result of local burning/ arcing but no fault could be found under test. However, a detailed visual inspection should reveal evidence of burning around the fault.

C. POLARITY CHECK

Appliance connected to mains supply and meter set on 300 Vac scale. Test at appliance terminal strip:-

a) Test leads from L to N - meter reads approx 240 Vac

b) Test leads from L to E (\oplus) - meter reads approx 240 Vac

c) Test leads from N to E (\oplus) - meter reads from 0-15 Vac*

Thus the terminal marked L is the live terminal. If the low* Vac reading is given on terminals other than N to E (\oplus) there is an electrical fault.

Repeat the test at the appliance plug/inlet spur to check the wiring system up to the appliance and rectify any fault. If necessary repeat the test at the supply system socket/spur - if the fault also occurs at this stage then there is a house system fault which requires attention by the ELECTRICITY AUTHORITY. The customer should be warned not to use the appliance until this examination has been carried out.

D. RESISTANCE TO EARTH CHECK

Appliance must be disconnected from mains supply and meter set on Ω (ohms) x 100 scale. All switches, including stats, ON - Test leads from L to E - if meter reads other than infinity (∞) there is a fault which should be isolated. A detailed continuity check is required to trace the faulty component.

IMPORTANT - This series of checks are the first electrical checks to be carried out during a fault finding procedure. On completion of the service/fault finding task which has required the breaking and remaking of electrical connections then the checks - A. Earth Continuity. C. Polarity and D. Resistance to Earth - must be repeated.

APPENDIX A VERTICAL FLUE INSTRUCTIONS

The Vokera Room sealed vertical flue terminal assembly is intended for use where a horizontal flue outlet is not possible or desired. It can be used with either a flat or pitched roof (max pitch 60 Degrees)(see figs 1,2, & 3). The vertical flue assembly consists of an annular co-axial combustion air intake, with a specially designed terminal fitted to the top. As supplied the flue assembly is 1050mm long overall and must not be cut to shorter dimensions, but may be extended using 850mm long extension tubes Part No. 026 (G.C. No 370 346) or 1700mm extension tubes part no. 016 to a maximum overall dimension of 4.5metres on the14/48 SP. Where a straight flue run is impossible due to an obstruction the flue may be offset using either a maximum of two fixed offsets (100mm) Part No. 060 (G.C. No 301 108) or four 45 Degree bends Part No 059 (G.C. No 301 107). If either a fixed offset or a pair of 45 Degree bends are used the maximum permissible flue height is reduced by 750mm. (See 3.4.5).

This assembly must be installed in accordance with BS 5440 part 1.

NOTE:
90° DEGREE FLUE BENDS MUST NOT BE USED ON THE VERTICAL FLUE.

NOTE
The 45° bends have one long and one short limb so may be assembled back to back in three different ways to give offsets of 130mm,192mm or 254mm (fig. 4). Offsets of greater distance may be made by using a straight length between the bends. (fig. 2)

VOKERA FLASHING PLATES

Flat - Part No. 061

Angled - Part No. 017 (adjustable 20° - 40°)

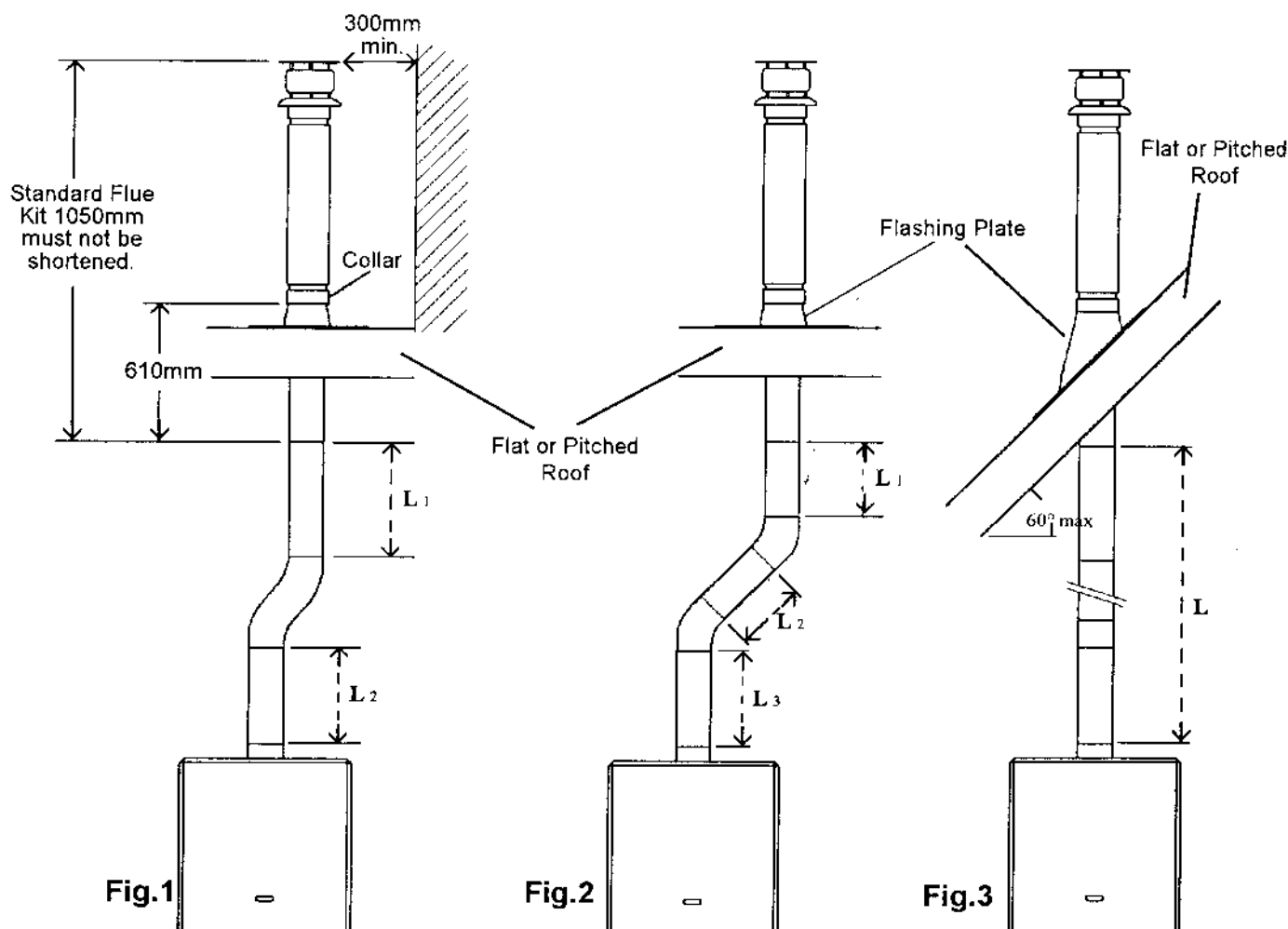

With 1 x Offset
 $L = L_1 + L_2 = 2700\text{mm (max)}$
 $2700 + 750 + 1050 = 4500\text{ (max)}$.

With 2 x 45° Bends
 $L = L_1 + L_2 + L_3 = 2700\text{mm (max)}$
 $2700 + 750 + 1050 = 4500\text{ (max)}$.

Straight Flue
 $L = 3450\text{mm}$
 (3 extension tubes)
 $3450 + 1050 = 4500\text{ (max)}$.

Fig. 4

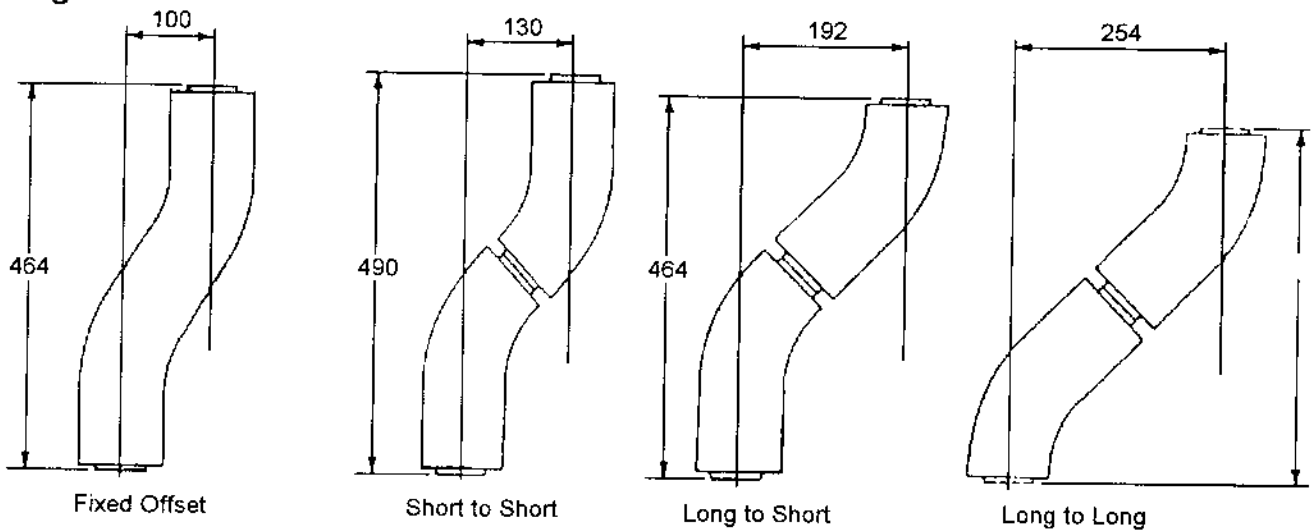

Proceed with installation as detailed in section 5 of the main installation and servicing Instructions, ignoring all references to the flue installations. It is advisable not to proceed beyond hanging the appliance on the bracket until the flue system is installed.

NOTE Where the vertical flue terminal assembly is used without extension, then the dimension W (fig 5) is dictated by the particular flashing plate used and is not variable. In this case calculate dimensions W before fixing the appliance mounting bracket. (See steps 5-10).

1. Mark the position of the flue hole in the ceiling and/or roof using the dimension Y in fig 5.
2. Ensure that the maximum permissible flue length is not exceeded and that allowance has been made for any bends or offset used. (figs 1,2 & 3)
3. Cut a 105mm diameter hole through the ceiling and/or roof.
4. Fit 100mm(4in) diameter flashing plate to the roof.

TO CONNECT THE FLUE DIRECTLY TO THE APPLIANCE PROCEED BELOW. (PRIOR TO FIXING APPLIANCE BRACKET) IF USING EXTENSION TUBES/OFFSET/BENDS START AT NUMBER 11.

5. Insert the vertical flue terminal assembly through the flashing plate from the outside.
6. Measure W. Then $W+X$ mm (see table) = distance from ceiling for appliance hanging bracket.

7. Fix the appliance hanging bracket and hang the appliance in accordance with section 5 of these Installation and Servicing Instructions.
8. Locate the small maintenance clip onto the appliance flue outlet spigot, (see insert fig.5) draw the flue assembly fully towards the appliance until it locates fully into the clip. Tighten clip retaining screws.
9. There should now be a gap approximately 15mm between the outer sleeve of the air duct and the air duct spigot, (see insert fig.5). Finally fit the large maintenance clip to seal this gap, ensure the screws are fully tightened.
10. Ensure that the collar on the flue assembly is located over the edge of the flashing plate. (fig.5)

FLUE CONNECTION USING EXTENSIONS/OFFSETS/BENDS

NOTE: The Offset or 45° Bends must not be cut.

11. Insert the vertical flue terminal through the flashing from the outside.
12. Measure the distance L between the inner flue tubes, or offset/bends (figs 1,2&3). Using the list below determine how many extension tubes are required.

- 1 extension - 850mm
 - 2 extensions - 1700mm
 - 3 extensions - 2550mm
 - 4 extensions - 3400mm
- (14/48 max. straight flue only)

13. Any shortening of extension tubes must be carried out on the end which does not have the screw retaining the inner and outer tubes together.
14. Remove the screw retaining the inner and outer tubes together.
15. Measure the distance between the inner tubes and cut the inner tube to this length. Using the piece cut off the inner tube mark the same length to be cut from the outer tube, which will leave the inner tube approximately 15mm longer than the outer tube.
16. Replace the screws to retain the inner and outer tube together.
17. Starting at the appliance end assemble the extension duct sections and Offset or Bends (if used) making each join by butting the inner (flue) tubes and securing with a small maintenance clip, then fitting a large maintenance clip to bridge the gap between the sections of the outer (air) tubes.
18. After making the last joint to the flue terminal assembly ensure that the collar on the outlet tube is still fully located over the edge of the flashing plate to give a waterproof seal. (fig.1) Trim the last section of the extension if necessary.
19. Tighten all maintenance clips, make sure that the entire flue is adequately supported. Use at least one bracket Part No. 03 (G.C. No 301 105) for each extension used.
20. Continue with installation as detailed in these Installation and Servicing Instructions.

Dimensions in mm

Boiler	X	Y
14/48 SP	87	162.5

Fig. 5

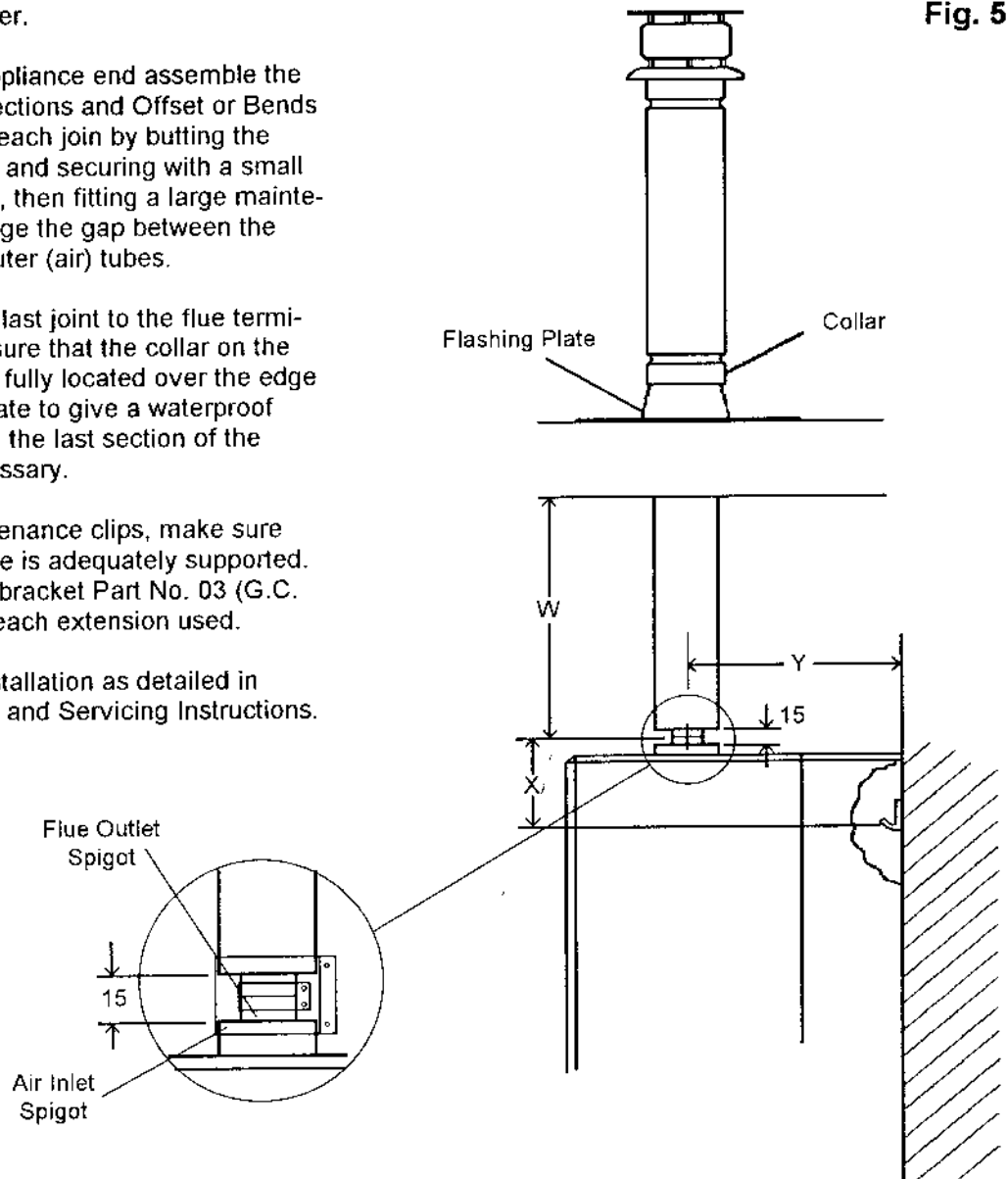





G.R. Claudio (Vokèra) Ltd

Head Office and Accounts: Clarisham House, Morson Road, Enfield, Middlesex EN3 4NQ Tel. 0181-804 7202 Fax 0181-804 8163

Northern Region: 360 Bowling Back Lane, Bradford, West Yorkshire BD4 8TS Tel. 01274 660314 Fax 01274-660446

Scottish Region: Shuna Street, Maryhill, Glasgow G20 9NW Tel. 0141-945 4944 Fax 0141-945 5136