

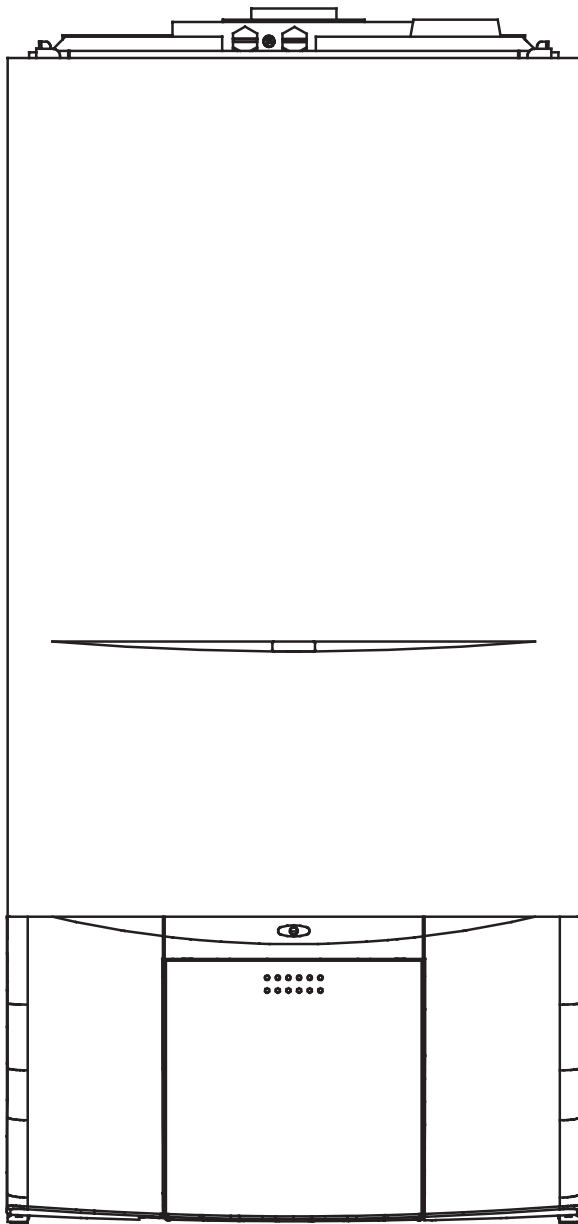

Linea



Installation & Servicing Instructions

CE

**THESE INSTRUCTIONS
TO BE RETAINED
BY USER**



The code of practice for the installation,
commissioning & servicing of central heating systems

Contents

Design principles and operating sequence		Page
1.1	Principle components	2
1.2	Mode of operation (at reset)	2
1.3	Mode of operation (Heating)	2
1.4	Mode of operation (DHW)	2
1.5	Safety devices	2
1.6	Optional accessories	2
Technical data		Page
2.1	Central heating	3
2.2	Domestic hot water	3
2.3	Gas pressure	3
2.4	Expansion vessel	3
2.5	Dimensions	3
2.6	Clearances	3
2.7	Connections	3
2.8	Electrical	3
2.9	Flue details (concentric)	3
2.9A	Flue details (twin pipes)	3
2.10	Efficiency	3
2.11	Pump duty	4
2.12	Emissions	4
General requirements (UK)		Page
3.1	Related documents	5
3.2	Location of appliance	5
3.3	Gas supply	5
3.4	Flue system	5
3.5	Air supply	5
3.6	Water circulation	5
3.6.1	Pipework	6
3.6.2	Automatic by-pass	6
3.6.3	Drain cocks	6
3.6.4	Air release points	6
3.6.5	Expansion vessel	6
3.6.6	Filling point	6
3.6.7	Low pressure sealed system	6
3.6.8	Frequent filling	6
3.7	Electrical supply	6
3.8	Showers	6
3.9	Mounting on a combustible surface	6
3.10	Timber framed building	7
3.11	Inhibitors	7
General requirements (EIRE)		Page
3.A1	Related documents	7
3.A2	Location of appliance	7
3.A3	Gas supply	7
3.A4	Flue system	8
3.A5	Air supply	8
3.A6	Water circulation	8
3.A6.1	Pipework	8
3.A6.2	Automatic by-pass	8
3.A6.3	Drain cocks	8
3.A6.4	Air release points	8
3.A6.5	Expansion vessel	8
3.A6.6	Filling point	8
3.A6.7	Low pressure sealed system	8
3.A6.8	Frequent filling	8
3.A7	Electrical supply	8
3.A8	Showers	8
3.A9	Mounting on a combustible surface	9
3.A10	Timber framed building	9
3.A11	Inhibitors	9
3.A12	Declaration of conformity	9
Installation		Page
4.1	Delivery	9
4.2	Contents	9
4.3	Unpacking	9
4.4	Preparation for mounting the appliance	9
4.5	Fitting the flue	9
4.5.1	Concentric horizontal flue	9
4.5.2	Concentric vertical flue	11
4.5.3	Twin flue system	12
4.6	Connecting the gas and water	14
4.6.1	Gas	14
4.6.2	Flow and return	14
4.6.3	Cold water inlet	14
4.6.4	Hot water outlet	15
4.6.5	Safety valve	15
4.7	Electrical connections	15
4.7.1	Casing removal	15
4.7.2	Appliance terminal block	15
4.7.3	Connecting the mains (230V) input	15
4.7.4	Connecting the Vokera time clock	16
Commissioning		Page
5.1	Gas supply installation	17
5.2	The heating system	17
5.3	Initial filling of the system	17
5.4	Initial flushing	17

5.5	Filling the hot water system	17
5.6	Pre-operation checks	17
5.7	Initial lighting	17
5.7.1	Checking burner pressures	17
5.8	Final flushing of the heating system	18
5.8.1	Inhibitors	18
5.9	Setting the boiler operating temperature	18
5.9.1	Setting the domestic hot water temperature	18
5.10	Setting the system design pressure	18
5.11	Regulating the hot water	18
5.11.1	Changing the flow restrictor	18
5.11.2	Regulating the central heating system	18
5.12	Final checks	19
5.13	Instructing the user	19
Servicing instructions		Page
6.1	General	19
6.2	Routine annual servicing	19
6.4	Component removal procedure	20
6.5	Pump assembly	20
6.6	Safety valve	20
6.7	Automatic air release valve	20
6.8	Water pressure switch	20
6.9	Pressure gauge	21
6.10	Primary thermistors	21
6.11	High limit thermostat	21
6.12	Printed circuit board	21
6.13	Gas valve	22
6.14	Integral time switch	22
6.15	Electrode, burner thermostat, burner & injectors	22
6.16	Flue fan	22
6.17	Main heat exchanger	24
6.18	Air pressure switch	24
6.19	Flow restrictor	24
6.20	DHW flow switch	25
6.21	DHW heat exchanger	25
6.22	Valve actuator	25
6.23	Divertor valve assembly	25
6.24	Secondary thermistor	25
6.25	Automatic by-pass	26
6.26	DHW non-return valve	26
6.27	Expansion vessel	26
6.27.1	Expansion vessel removal	26
6.27.2	Expansion vessel removal	26
Checks, adjustments and fault finding		page
7.1	Checking appliance operation	27
7.2	Appliance mode of operation	27
7.2.1	Selector switch in the off position	27
7.2.2	Selector switch in the hot water only position	27
7.2.3	Selector switch in the heating & hot water position	27
7.2.4	Appliance functions	27
7.2.5	Heating mode	27
7.2.6	DHW mode	28
7.3	Checking and adjusting burner pressure	28
7.3.1	Setting the maximum burner pressure	28
7.3.2	Setting the minimum burner pressure	28
7.4	Combustion analysis test	29
7.5	Checking the expansion vessel	29
7.6	External faults	29
7.6.1	Installation faults	29
7.7	Electrical checks	29
7.7.1	Earth continuity test	29
7.7.2	Short circuit test	29
7.7.3	Polarity check	29
7.7.4	Reversed polarity or supply fault	30
7.7.5	Resistance to earth check	30
7.8	Fault finding	30
7.8	Fault codes	31-38
Wiring diagrams		Page
8.1	External wiring	39
8.2	Typical control applications	39
8.3	Vokera time clock	39
8.4	Vokera remote control	39
8.5	Vokera room thermostat	39
8.6	Other controls	39
Exploded diagrams		Page
Table 1		43
Table 2		44
Table 3		45
Table 4		46
Table 5		47
L.P.G. instructions		Page
10.1	Related documents	48
10.3	Converting the appliance gas type	48
10.4	Gas supply	48
10.5	Gas supply installation	48
10.6	Checking and adjusting burner pressure	48
10.6.1	Setting the maximum burner pressure	48
10.6.2	Setting the minimum burner pressure	48

INTRODUCTION

The Linea 7 range is comprised of 3 models of combination boiler – 726, 730, 735 – with outputs to heating & DHW of 26, 30 & 35 kW respectively. Each appliance – by design – incorporates electronic ignition, circulating pump, expansion vessel, safety valve, pressure gauge, and automatic by-pass.

The Linea 7 range are produced as room sealed, category II2H3+ appliances, suitable for internal wall mounting applications only. They are provided with a fan powered flue outlet with an annular co-axial combustion air

intake that can be rotated – horizontally – through 360 degrees for various horizontal or vertical applications. The Linea 7 range can also be used with the Vokera twin flue system.

The Linea 7 range is approved for use with C12, C22, & C32 type flue applications.

These appliances are designed for use with a sealed system only; consequently they are not intended for use on open vented systems.

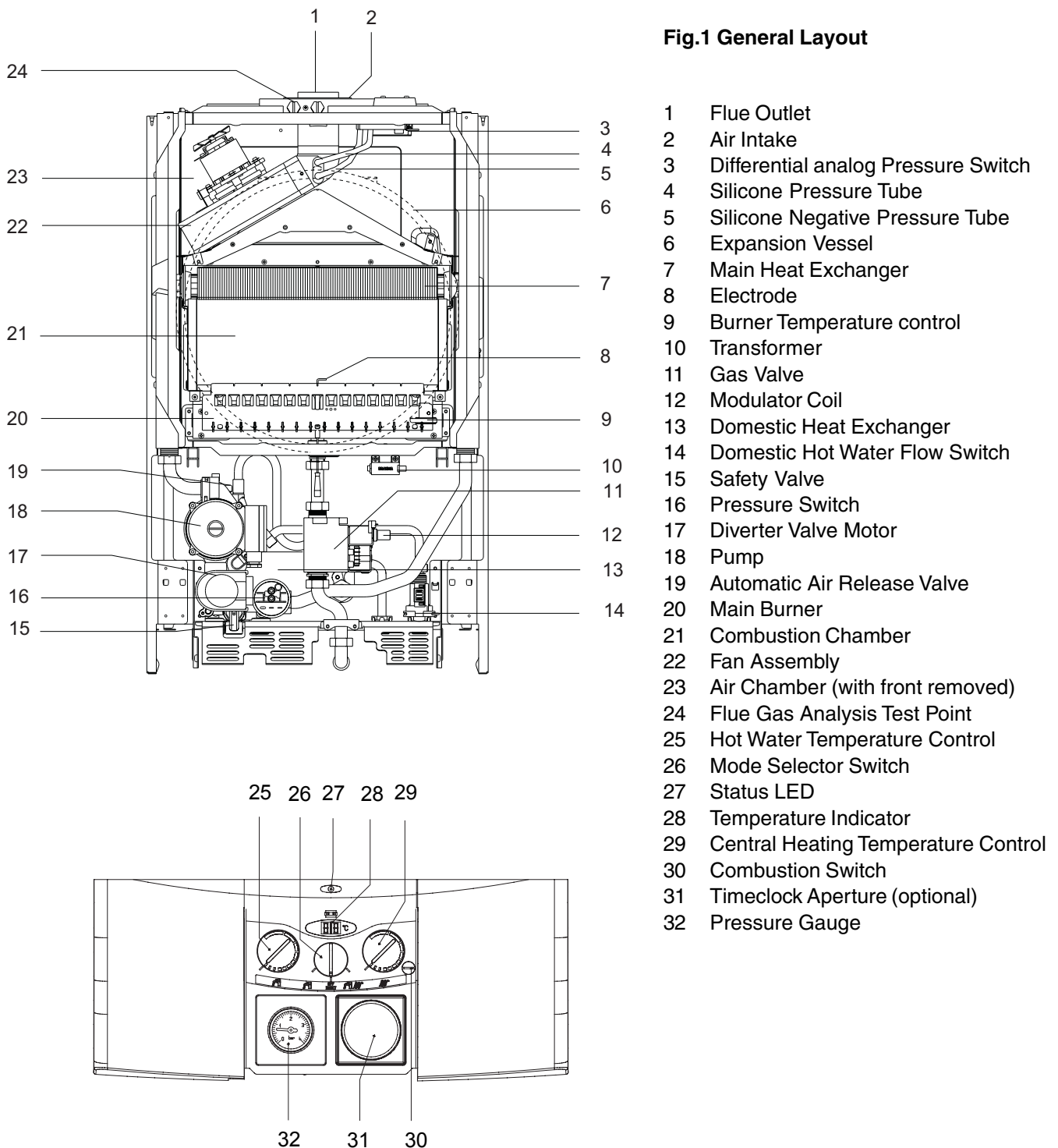

Fig. 1

1.1 PRINCIPLE COMPONENTS

- A fully integrated electronic control board featuring electronic temperature control, anti-cycle control, pump over-run, self-diagnostic fault indicator, full air/gas modulation.
- Low-water-content, copper heat exchanger.
- Electronic ignition with flame supervision
- Integral high-head pump
- Fan
- Expansion vessel
- Analogue pressure switch (PAD)
- Water pressure switch
- Two-stage gas valve
- Pressure gauge
- Safety valve
- Burner Temperature control

1.2 MODE OF OPERATION (at rest)

When the appliance is at rest and there are no requests for heating or DHW, the following functions are active:

- Pre-heat function – the pre-heat function enables the appliance to periodically light and maintain the temperature of the DHW heat exchanger. This “keep-hot” facility enables the appliance to provide an instantaneous response to DHW requests.
- 2-stage frost-protection system – the frost-protection system protects the appliance against the risk of frost damage. The first stage enables activation of the pump should the temperature of the appliance fall to 7°C. The second stage becomes active when the temperature has dropped to 3°C. Should the second stage become active, the appliance will function on minimum power until it reaches 30°C.
- Anti-block function – the anti-block function enables the pump and divertor valve actuator, to be energised for short periods, when the appliance has been inactive for more than 19-hours.

1.3 MODE OF OPERATION (Heating)

When there is a request for heat via the programmer/time clock and/or any external control, the pump and fan are started, the fan speed will modulate until the correct signal voltage is received at the control PCB. At this point an ignition sequence is enabled.

Ignition is sensed by the electronic circuitry to ensure flame stability at the burner. Once successful ignition has been achieved, the electronic circuitry increases the gas rate to 75% for a period of 15 minutes. Thereafter, the boiler’s output will either be increase to maximum or modulate to suit the set requirement.

When the appliance reaches the desired temperature the burner will shut down and the boiler will perform a three-minute anti-cycle (timer delay). When the request for heat has been satisfied the appliance pump and fan may continue to operate to dissipate any residual heat within the appliance.

1.4 MODE OF OPERATION (DHW)

When there is a request for DHW via a hot water outlet or tap, the pump and fan are started, the fan speed will modulate until the correct signal voltage is received at the control PCB. At this point an ignition sequence is enabled. Ignition is sensed by the electronic circuitry to

ensure flame stability at the burner. Once successful ignition has been achieved, the electronic circuitry increases the gas rate to maximum or will modulate output to stabilise the temperature. In the event of the appliance exceeding the desired temperature the burner will shut down until the temperature drops.

When the request for DHW has been satisfied the appliance pump and fan may continue to operate to dissipate any residual heat within the appliance.

1.5 SAFETY DEVICES

When the appliance is in use, safe operation is ensured by:

- A water pressure switch that monitors system water pressure and will de-activate the pump, fan, and burner should the system water pressure drop below the rated tolerance.
- A high limit thermostat that over-rides the temperature control circuit to prevent or interrupt the operation of the burner.
- An analogue pressure switch (PAD) that checks the operation of the fan and flue thereby allowing safe operation of the burner.
- A safety valve which releases excess pressure from the primary circuit.
- Burner Temperature control

1.6 OPTIONAL ACCESSORIES

The Linea 7 is suitable for use with a range of optional accessories that enable enhanced operation and/or applications. These include:

- RC05 remote control – the RC05 remote control enables the appliance to be controlled, adjusted, and monitored from another location or room. The RC05 can also be used as a room thermostat or programmable room thermostat.
- External sensor – used in conjunction with the RC05 the external sensor enables the appliance to automatically adjust its outlet flow temperature in response to the outside temperature.

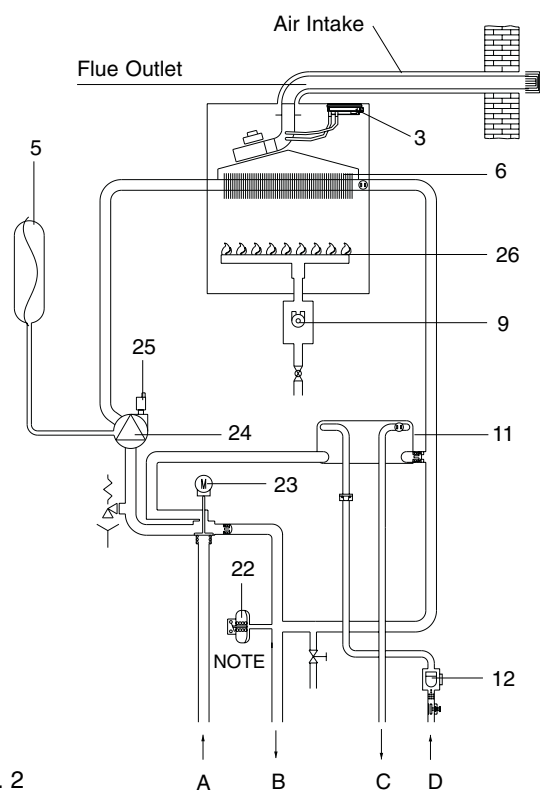

Fig. 2

SECTION 2 TECHNICAL DATA

2.1 Central heating	726	730	735
Heat input (kW)	28.2	32.6	37.8
Maximum heat output (kW)	26.0	30.1	35.2
Minimum heat output (kW)	8.28	8.93	9.22
Minimum working pressure	0.45 bar		
Maximum working pressure	3.0 bar		
Minimum flow rate	350 l/h		
2.2 Domestic hot water			
Maximum input (kW)	28.2	32.6	37.8
Maximum output (kW)	26.0	30.1	35.2
Minimum output (kW)	8.28	8.93	9.22
Flow rate (35°C rise)	10.6 l/min	12.3 l/min	14.4 l/min
Maximum inlet pressure	6.0 bar		
Minimum inlet pressure	0.15 bar		
Minimum flow rate	2.5 l/min		
2.3 Gas pressures			
Inlet pressure (G20)	20.0 mbar		
Burner pressure maximum	9.8 mbar		9.6 mbar
Burner pressure minimum	1.1 mbar	0.8 mbar	0.7 mbar
Maximum gas rate	2.98 m ³ /h	3.45 m ³ /h	4 m ³ /h
Minimum gas rate	0.95 m ³ /h	1.02 m ³ /h	1.05 m ³ /h
Injector size (quantity)	12 x 1.4 mm	14 x 1.4 mm	16 x 1.4 mm
2.4 Expansion vessel			
Capacity	8-litres		10-litres
Maximum system volume	76-litres		95-litres
Pre-charge pressure	1.0 bar		
2.5 Dimensions			
Height	820mm		
Width	400mm	450mm	500mm
Depth	350mm		
Dry weight (kg)	37.0	40.0	46.0
2.6 Clearances			
Sides	12mm		
Top	150mm from casing or 25mm above flue elbow (whichever is applicable)		
Bottom	150mm		
Front	600mm		
2.7 Connections			
Flow & return	22mm		
Hot & cold water	15mm		
Gas	15mm		
Safety valve	15mm		
2.8 Electrical			
Voltage (V/Hz)	230/50		
Power consumption	140W	150W	160W
Internal fuse	2A		
External fuse	3A		
2.9 Flue details (concentric)			
Maximum horizontal flue length (60/100mm)	4.0m	3.4m	2m
Maximum vertical flue length (60/100mm)	4.8m	4.2m	2.8m
Maximum horizontal flue length (80/125mm)	10.0m	8.5m	5m
Maximum vertical flue length (80/125mm)	10.8m	9.3m	5.8m
2.9A Flue Details (twin pipes)			
Maximum horizontal flue length (80mm + 80mm)	14m+14m	14m+14m	7m+7m
Maximum vertical flue length (80mm + 80mm)	14m+14m	14m+14m	7.8m+7.8m
2.10 Efficiency			
SEDBUK (%)	80.3	80.3	80.3

SECTION 2 TECHNICAL DATA

2.11 PUMP DUTY

Fig. 3 shows the flow-rate available – after allowing for pressure loss through the appliance – for system requirements. When using this graph, apply only the pressure loss of the system. The graph is based on a 20°C temperature differential.

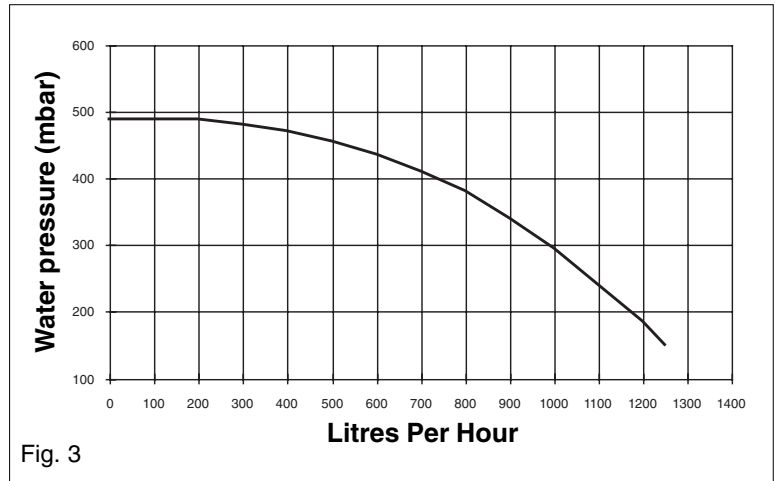
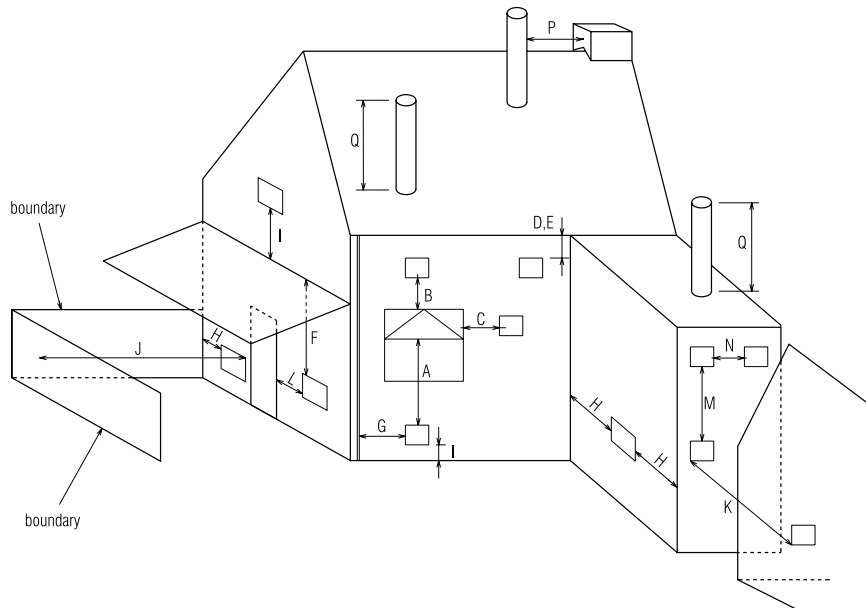

Fig. 3

2.12 Emissions

Appliance	726	730	735
NOx max/min	160/140	180/120	150/130
CO max/min	120/120	140/100	130/130
CO2 max/min	6.95/3.45	6.70/3.20	7.0/3.40
CO/CO2 ratio max/min	0.0017 to 1/0.0035 to 1	0.0021 to 1/0.0031 to 1	0.0019 to 1/0.0038 to 1

Fig. 4



Key	Location	Minimum distance
A	Below an opening (window, air-brik, etc.)	300 mm
B	Above an opening (window, air-brik, etc.)	300 mm
C	To the side of an opening (window, air-brik, etc.)	300 mm
D	Below gutter, drain-pipe, etc.	75 mm
E	Below eaves	200 mm
F	Below balcony, car-port roof, etc.	200 mm
G	To the side of a soil/drain-pipe, etc.	150 mm
H	From internal/external corner or boundary	300 mm
I	Above ground, roof, or balcony level	300 mm
J	From a surface or boundary facing the terminal	600 mm
K	From a terminal facing a terminal	1200 mm
L	From an opening in the car-port into the building	1200 mm
M	Vertically from a terminal on the same wall	1500 mm
N	Horizontally from a terminal on the same wall	300 mm
P	From a structure to the side of the vertical terminal	300 mm
Q	From the top of the vertical terminal to the roof flashing	As determined by the fixed collar of the vertical terminal

SECTION 3 GENERAL REQUIREMENTS (UK)

This appliance must be installed by a competent person in accordance with the Gas Safety (Installation & Use) Regulations.

3.1 RELATED DOCUMENTS

The installation of this boiler must be in accordance with the relevant requirements of the Gas Safety (Installation & Use) Regulations, the local building regulations, the current I.E.E. wiring regulations, the bylaws of the local water undertaking, the Building Standards (Scotland) Regulation and Building Standards (Northern Ireland) Regulations.

It should be in accordance also with any relevant requirements of the local authority and the relevant recommendations of the following British Standard Codes of Practice.

3.2 LOCATION OF APPLIANCE

The appliance may be installed in any room or internal space, although particular attention is drawn to the requirements of the current I.E.E. wiring regulations and in Scotland, the electrical provisions of the Building Regulations, with respect to the installation of the appliance in a room or internal space containing a bath or shower.

3.3 GAS SUPPLY

The gas meter – as supplied by the gas supplier – must be checked to ensure that it is of adequate size to deal with the maximum rated input of all the appliances that it serves. Installation pipes must be fitted in accordance with BS 6891.

Pipe work from the meter to the appliance must be of adequate size. Pipes of a smaller size than the appliance gas inlet connection must not be used. The installation must be tested for soundness in accordance with BS6891.

If the gas supply serves more than one appliance, it must be ensured that an adequate supply is maintained to each appliance when they are in use at the same time.

3.4 FLUE SYSTEM

The terminal should be located where the dispersal of combustion products is not impeded and with due regard for the damage and discoloration that may occur to building products located nearby. The terminal must not be located in a place where it is likely to cause a nuisance (see fig. 4).

BS 5440	PART 1	FLUES
BS 5440	PART 2	FLUES & VENTILATION
BS 5449	PART 1	FORCED CIRCULATION HOT WATER SYSTEMS
BS 5546		INSTALLATION OF GAS HOT WATER SUPPLIES FOR DOMESTIC PURPOSES (2 nd FAMILY GASES)
BS 6798		INSTALLATION OF BOILERS OF RATED INPUT NOT EXCEEDING 60kW
BS 6891		LOW PRESSURE INSTALLATION PIPES
BS 7074	PART 1	APPLICATION, SELECTION, AND INSTALLTION OF EXPANSION VESSELS AND ANCILLARY EQUIPMENT FOR SEALED WATER SYSTEMS

When an appliance is installed in a room or internal space containing a bath or shower, the appliance or any control pertaining to it must not be within reach of a person using the bath or shower. The location chosen for the appliance must permit the provision of a safe and satisfactory flue and termination. The location must also permit an adequate air supply for combustion purposes and an adequate space for servicing and air circulation around the appliance. Where the installation of the appliance will be in an unusual location special procedures may be necessary. BS 6798 gives detailed guidance on this aspect.

A compartment used to enclose the appliance must be designed and constructed specifically for this purpose. An existing compartment/cupboard may be utilised provided that it is modified to suit. Details of essential features of compartment/cupboard design including airing cupboard installations are given in BS 6798. This appliance is not suitable for external installation.

3.4 FLUE SYSTEM (Cont'd.)

In cold and/or humid weather, water vapour may condense on leaving the terminal; the effect of such plumbing must be considered.

If installed less than 2m above a pavement or platform to which people have access (including balconies or flat roofs) the terminal must be protected by a guard of durable material. The guard must be fitted centrally over the terminal. Refer to BS 5440 Part 1, when the terminal is 0.5 metres (or less) below plastic guttering or 1 metre (or less) below painted eaves.

3.5 AIR SUPPLY

The following notes are intended for general guidance only.

This appliance is a room-sealed, fan-flued boiler, consequently it does not require a permanent air vent for combustion air supply. When installed in a cupboard or compartment, ventilation for cooling purposes is also not required.

3.6 WATER CIRCULATION

Detailed recommendations are given in BS 5449 Part 1 and BS 6798. The following notes are for general guidance only.

3.6.1 PIPEWORK

It is recommended that copper tubing to BS 2871 Part 1 is used in conjunction with soldered capillary joints.

Where possible pipes should have a gradient to ensure air is carried naturally to air release points and that water flows naturally to drain cocks.

Except where providing useful heat, pipes should be insulated to avoid heat loss and in particular to avoid the possibility of freezing. Particular attention should be paid to pipes passing through ventilated areas such as under floors, loft space, and void areas.

3.6.2 AUTOMATIC BY-PASS

The appliance has a built-in automatic by-pass, consequently there is no requirement for an external by-pass, however the design of the system should be such that it prevents boiler 'cycling'.

3.6.3 DRAIN COCKS

These must be located in accessible positions to facilitate draining of the appliance and all water pipes connected to the appliance. The drain cocks must be manufactured in accordance with BS 2879.

3.6.4 AIR RELEASE POINTS

These must be positioned at the highest points in the system where air is likely to be trapped. They should be used to expel trapped air and allow complete filling of the system.

3.6.5 EXPANSION VESSEL

The appliance has an integral expansion vessel to accommodate the increased volume of water when the system is heated. It can accept up to 8 litres (726/730) of expansion from within the system, generally this is sufficient, however if the system has an unusually high water content, it may be necessary to provide additional expansion capacity (see 6.19).

3.6.6 FILLING POINT

A method for initial filling of the system and replacing water lost during servicing etc. has been provided. This method of filling complies with the current Water Supply (Water Fittings) Regulations 1999 and Water Bylaws 2000 (Scotland).

3.6.7 LOW PRESSURE SEALED SYSTEM

An alternative method of filling the system would be from an independent make-up vessel or tank mounted in a position at least 1 metre above the highest point in the system and at least 5 metres above the boiler (see fig. 5).

The cold feed from the make-up vessel or tank

must be fitted with an approved non-return valve and stopcock for isolation purposes. The feed pipe should be connected to the return pipe as close to the boiler as possible.

3.6.8 FREQUENT FILLING

Frequent filling or venting of the system may be indicative of a leak. Care should be taken during the installation of the appliance to ensure all aspects of the system are capable of withstanding pressures up to at least 3 bar.

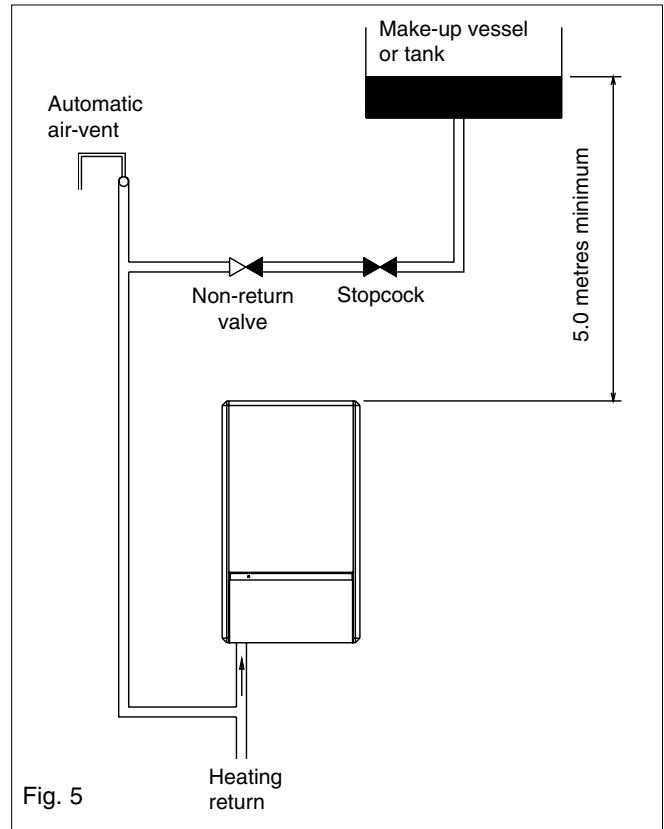

3.7 ELECTRICAL SUPPLY

The appliance is supplied for operation on 230V @ 50Hz electrical supply; it must be protected with a 3-amp fuse. The method of connection to the mains electricity supply must allow for complete isolation from the supply. The preferred method is by using a double-pole switch with a contact separation of at least 3mm. The switch must only supply the appliance and its corresponding controls, i.e. time clock, room thermostat, etc. Alternatively an un-switched shuttered socket with a fused 3-pin plug both complying with BS 1363 is acceptable.

3.8 SHOWERS

If the appliance is intended for use with a shower, the shower must be thermostatically controlled and be suitable for use with a combination boiler.

3.9 MOUNTING ON A COMBUSTIBLE SURFACE

If the appliance is to be fitted on a wall of combustible material, a sheet of fireproof material must protect the wall.

Pipe work from the meter to the appliance must be of adequate size. Pipes of a smaller size than the appliance gas inlet connection must not be used. The installation must be tested for soundness in accordance with I.S. 813.

If the gas supply serves more than one appliance, it must be ensured that an adequate supply is maintained to each appliance when they are in use at the same time.

3A.4 FLUE SYSTEM

The terminal should be located where the dispersal of combustion products is not impeded and with due regard for the damage and discoloration that may occur to building products located nearby. The terminal must not be located in a place where it is likely to cause a nuisance (see I.S. 813).

In cold and/or humid weather, water vapour may condense on leaving the terminal; the effect of such plumbing must be considered.

If installed less than 2m above a pavement or platform to which people have access (including balconies or flat roofs) the terminal must be protected by a guard of durable material. The guard must be fitted centrally over the terminal. Refer to I.S. 813, when the terminal is 0.5 metres (or less) below plastic guttering or 1 metre (or less) below painted eaves.

3A.5 AIR SUPPLY

The following notes are intended for general guidance only.

This appliance is a room-sealed, fan-flued boiler, consequently it does not require a permanent air vent for combustion air supply.

When installed in a cupboard or compartment, ventilation for cooling purposes is also not required.

3A.6 WATER CIRCULATION

Specific recommendations are given in I.S. 813. The following notes are for general guidance only.

3A.6.1 PIPEWORK

It is recommended that copper tubing be used in conjunction with soldered capillary joints.

Where possible pipes should have a gradient to ensure air is carried naturally to air release points and that water flows naturally to drain cocks.

Except where providing useful heat, pipes should be insulated to avoid heat loss and in particular to avoid the possibility of freezing. Particular attention should be paid to pipes passing through ventilated areas such as under floors, loft space, and void areas.

3A.6.2 AUTOMATIC BY-PASS

The appliance has a built-in automatic by-pass, consequently there is no requirement for an external by-pass, however the design of the system should be such that it prevents boiler 'cycling'.

3A.6.3 DRAIN COCKS

These must be located in accessible positions to facilitate draining of the appliance and all water pipes connected to the appliance.

3A.6.4 AIR RELEASE POINTS

These must be positioned at the highest points in the system where air is likely to be trapped. They should be used to expel trapped air and allow complete filling of the system.

3A.6.5 EXPANSION VESSEL

The appliance has an integral expansion vessel to accommodate the increased volume of water when the system is heated. It can accept up to 8 litres (726/730) or 10 litres (735) of expansion from within the system, generally this is sufficient, however if the system has an unusually high water content, it may be necessary to provide additional expansion capacity (see 6.19).

3A.6.6 FILLING POINT

A method for initial filling of the system and replacing water lost during servicing etc. has been provided. You should ensure this method of filling complies with the local water authority regulations.

3A.6.7 LOW PRESSURE SEALED SYSTEM

An alternative method of filling the system would be from an independent make-up vessel or tank mounted in a position at least 1 metre above the highest point in the system and at least 5 metres above the boiler (see fig. 5).

The cold feed from the make-up vessel or tank must be fitted with an approved non-return valve and stopcock for isolation purposes. The feed pipe should be connected to the return pipe as close to the boiler as possible.

3A.6.8 FREQUENT FILLING

Frequent filling or venting of the system may be indicative of a leak. Care should be taken during the installation of the appliance to ensure all aspects of the system are capable of withstanding pressures up to at least 3 bar.

3A.7 ELECTRICAL SUPPLY

The appliance is supplied for operation on 230V @ 50Hz electrical supply; it must be protected with a 3-amp fuse. The method of connection to the mains electricity supply must allow for complete isolation from the supply. The preferred method is by using a double-pole switch with a contact separation of at least 3mm. The switch must only supply the appliance and its corresponding controls, i.e. time clock, room thermostat, etc.

3A.8 SHOWERS

If the appliance is intended for use with a shower, the shower must be thermostatically controlled and be suitable for use with a combination boiler.

3A.9 MOUNTING ON A COMBUSTIBLE SURFACE

If the appliance is to be fitted on a wall of combustible material, a sheet of fireproof material must protect the wall.

3A.10 TIMBER FRAMED BUILDINGS

If the appliance is to be fitted in a timber framed building, it should be fitted in accordance with I.S. 813 and local Building Regulations.

The Institute of Gas Engineers publication (IGE/UP/7) 'Guide for Gas Installations in Timber Frame Buildings' gives specific advice on this type of installation.

3A.11 INHIBITORS

Vokera recommend that a inhibitor – suitable for use with low water-content, copper heat exchang-

ers – is used to protect the boiler and system from the effects of corrosion and/or electrolytic action. The inhibitor must be administered in strict accordance with the manufacturers* instructions. *Ferrox and Sentinel manufacture products that have proved suitable for use with Vokera appliances. Vokera Ltd. cannot comment on the suitability of any other such product with our appliances.

3A.12 DECLARATION OF CONFORMITY

A Declaration of Conformity (as defined in I.S. 813) must be provided on completion of the installation

A copy of the declaration must be given to the responsible person and also to the gas supplier if required.

SECTION 4 INSTALLATION

4.1 DELIVERY

Due to the weight of the appliance it may be necessary for two people to lift and attach the appliance to its mounting. The appliance is contained within a heavy-duty cardboard carton. Lay the carton on the floor with the writing the correct way up.

4.2 CONTENTS

Contained within the carton is:

- The boiler
- The fixing jig and wall bracket
- Template
- An accessories pack containing appliance service connections and washers
- The instruction pack containing the installation & servicing instructions, user instructions, Benchmark logbook, guarantee registration card, and a 3-amp fuse

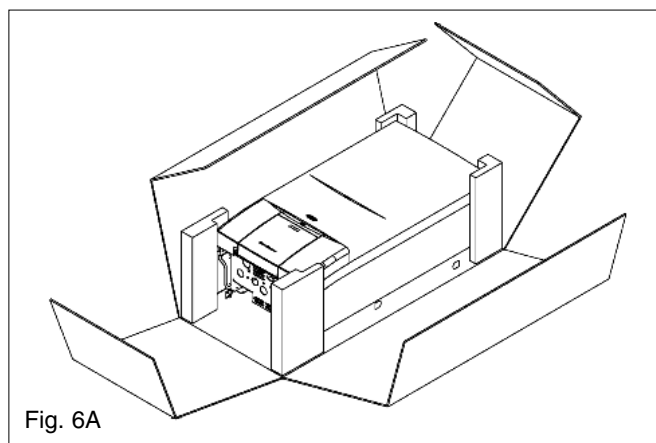

Fig. 6A

4.3 UNPACKING (fig. 6A)

At the top of the carton pull both sides open – do not use a knife – unfold the rest of the carton from around the appliance, carefully remove all protective packaging from the appliance, and lay the accessories etc. to one side. Protective

gloves should be used to lift the appliance, the appliance back-frame should be used for lifting points.

4.4 PREPARATION FOR MOUNTING THE APPLIANCE

The appliance should be mounted on a smooth, vertical, non-combustible surface, which must be capable of supporting the full weight of the appliance. Care should be exercised when determining the position of the appliance with respect to hidden obstructions such as pipes, cables, etc. When the position of the appliance has been decided – using the template supplied – carefully mark the position of the combined fixing jig and wall-mounting bracket (see fig. 6) and flue-hole (if applicable).

4.5 FITTING THE FLUE

The top flue outlet permits both horizontal and vertical flue applications to be considered, alternatively, the Vokera twin flue system can be utilised if longer flue runs are required.

4.5.1 CONCENTRIC HORIZONTAL FLUE

(For concentric vertical flue, see 4.5.2)

(For twin flue applications, see 4.5.3)

The appliance can be used with either the standard 60/100mm concentric flue system or the optional 80/125mm concentric flue system.

NOTE

These instructions relate **only** to the standard 60/100mm concentric flue system. For specific details on the installation of the 80/125mm concentric flue system please refer to the instructions supplied.

The appliance flue outlet elbow can be rotated through 360° on its vertical axis. In addition the flue may be extended from the outlet elbow in the horizontal plane (see 2.9). A reduction must also be made to the maximum length (see table below) when additional bends are used.

Reduction for additional bends

Bend	Reduction in maximum flue length for each bend
45° bend	0.5 metre
90° bend	1.0 metre

Horizontal flue terminals and accessories

Part No.	Description	Min-Max Length
2359029	Standard flue kit. For use with add. Bends & extensions	833mm (dimension 'X')
2359119	Telescopic flue kit.	
2359069	750mm extension	750mm
2359079	1500mm extension	1500mm
2359089	Telescopic extension	350 – 490mm
2359049	45° bend (pair)	N/A
2359059	90° bend	N/A
0225760	Wall bracket (5)	N/A

Using the template provided, mark and drill a 107mm hole for the passage of the flue pipe. The hole should have a 1° drop from the boiler to outside, to eliminate the possibility of rainwater entering the appliance via the flue.

The fixing holes for the wall-mounting bracket/fixing jig should now be drilled and plugged, an appropriate type and quantity of fixing should be used to ensure that the bracket/jig is mounted securely. Once the bracket/jig has been secured to the wall, mount the appliance onto the bracket.

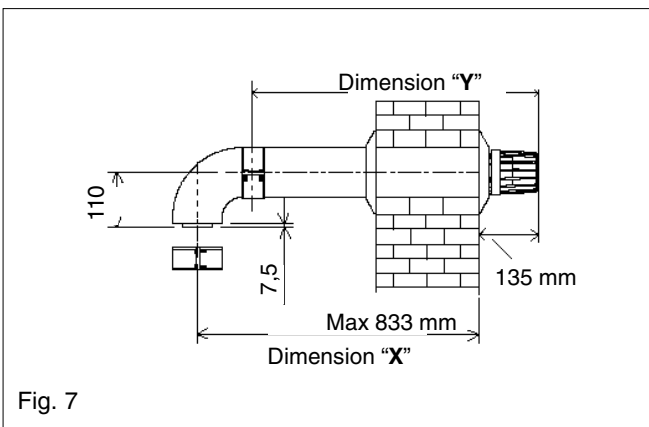

Fig. 7

4.5.1.1 FITTING THE HORIZONTAL FLUE KIT (see 4.5.1)

Carefully measure the distance from the centre of the appliance flue outlet to the face of the outside wall (dimension 'X' see fig. 7). Ensure the inner (60mm) pipe is fully inserted into the outer (100mm) pipe (when the inner pipe is fully inserted, it stands proud of the outer pipe by 7.5mm). Add 32mm to dimension 'X' to give the overall flue length (dimension 'Y').

NOTE

The standard horizontal flue kit (part no. 2359029) is suitable for a distance (dimension 'Y') of up to 865mm.

The telescopic flue kit (part no. 2359119) is suitable for a distance (dimension 'Y') of up to 600mm.

Dimension 'Y' is measured from the end of the terminal to the end of the outer (100mm) pipe.

The internal trim should be fitted to the flue pipe before connection of the 90° bend.

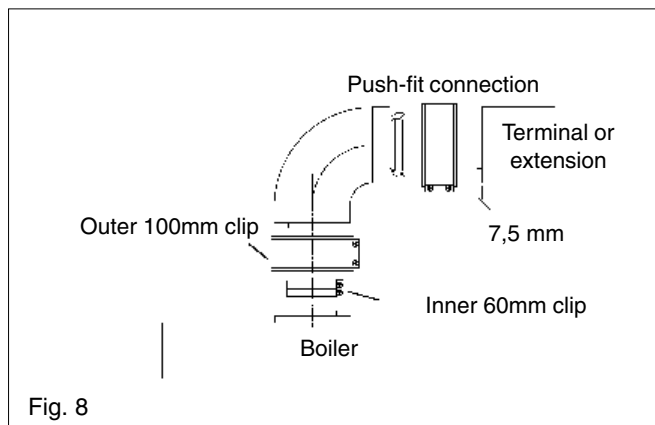

Fig. 8

Using the dimensions given in fig. 9 as a reference, mark and cut a 105mm hole in the ceiling and/or roof.

Fit the appropriate flashing plate to the roof and insert the vertical flue terminal through the flashing plate from the outside, ensuring that the collar on the flue terminal fits over the flashing.

The fixing holes for the wall-mounting bracket should now be drilled and plugged, an appropriate type and quantity of fixing should be used to ensure that the bracket is mounted securely. Once the bracket has been secured to the wall, mount the appliance onto the bracket.

If the horizontal flue kit (2359029) requires to be cut to the correct size (dimension 'Y'), you must ensure that the inner (60mm) pipe stands proud of the outer (100mm) pipe by 7.5mm (see fig. 8). Ensure any burrs are filed or removed and that any seals are located properly before assembly.

The telescopic flue terminal should be adjusted to the appropriate length and then fixed using the securing screw supplied.

4.5.1.2 STANDARD FLUE KIT (2359029)

Hold the inner (60mm) pipe of the terminal assembly and connect to the push-fit end of the 90° bend (supplied) using a twisting action. Insert the assembled flue into the previously drilled hole. Using the clips & screws supplied, connect the flue assembly to the boiler, ensuring that the terminal protrudes past the finished outside wall by the correct length (135mm).

4.5.1.3 TELESCOPIC FLUE KIT (2359119)

Connect the 60mm push-fit connection of the flue bend (supplied) to the telescopic flue assembly using a twisting action. Insert the assembled flue into the previously drilled hole. Using the clips & screws supplied, connect the flue assembly to the boiler, ensuring that the terminal protrudes past the finished outside wall by the correct length (135mm).

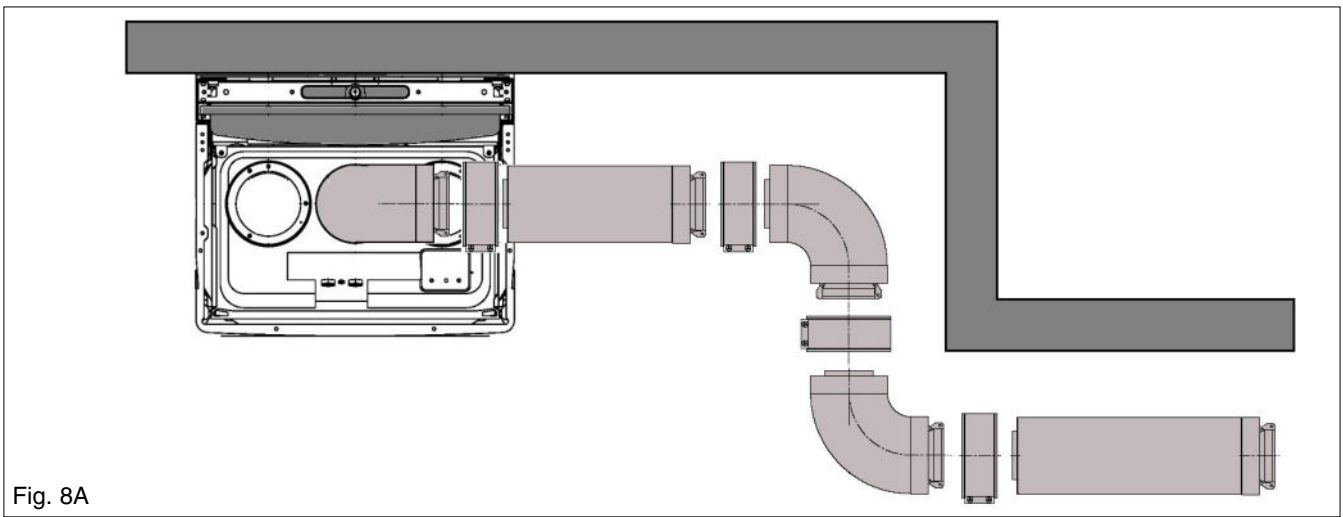

Fig. 8A

You must ensure that the entire flue system is properly supported and connected. Seal the flue assembly to the wall using cement or a suitable alternative that provides satisfactory weatherproofing. The exterior trim can now be fitted.

4.5.1.4 EXTENDING THE HORIZONTAL FLUE

The horizontal flue system can be extended using bends and/or extensions from the Uni-Flue range (see 4.5.1).

Connect the bend – supplied with the terminal kit – to the top of the boiler using the clips, screws, & gaskets supplied. The additional bends & extensions have an internal push-fit connection, care should be taken to ensure that the correct seal is made when assembling the flue system. Connect the required number of flue extensions or bends (up to the maximum equivalent flue length) to the flue terminal using the clips, screws, & gaskets supplied (see fig. 8 & 8A). The interior trim should be fitted at this point.

NOTE

When cutting an extension to the required length, you must ensure that the excess is cut from the plain end of the extension, and that the inner (60mm) pipe is 7.5mm longer than outer (100mm) pipe (see fig. 8 & 8A). Remove any burrs, and check that any seals are located properly.

You must ensure that the entire flue system is properly supported and connected. Seal the flue assembly to the wall using cement or a suitable alternative that will provide satisfactory weatherproofing. The exterior trim can now be fitted.

4.5.2 CONCENTRIC VERTICAL FLUE

The appliance can be used with either the standard 60/100mm concentric flue system or the optional 80/125mm concentric flue system.

NOTE

These instructions relate **only** to the standard 60/100mm concentric flue system. For specific details on the installation of the 80/125mm concentric flue system please refer to the instructions supplied.

The vertical flue terminal can be connected directly to the appliance flue outlet. Alternatively,

an extension or bend can be connected to the appliance flue outlet if desired (see 4.4.2), however if additional bends are fitted, a reduction must be made to the maximum flue length (see table below).

Reduction for bends

Bend	Reduction in maximum flue length for each bend
45° bend	0.5 metre
90° bend	1.0 metre

Vertical flue terminal and accessories

Part No.	Description	Length
2359039	Vertical flue terminal	1.0 metre
0225770	Pitched roof flashing plate	N/A
0225765	Flat roof flashing plate	N/A
2359069	750mm extension	750mm
2359079	1500mm extension	1500mm
2359049	45° bend (pair)	N/A
2359059	90° bend	N/A
0225760	Wall bracket (5)	N/A

Using the dimensions given in fig. 9 as a reference, mark and cut a 105mm hole in the ceiling and/or roof.

Fit the appropriate flashing plate to the roof and insert the vertical flue terminal through the flashing plate from the outside, ensuring that the collar on the flue terminal fits over the flashing.

The fixing holes for the wall-mounting bracket should now be drilled and plugged, an appropriate type and quantity of fixing should be used to ensure that the bracket is mounted securely. Once the bracket has been secured to the wall, mount the appliance onto the bracket.

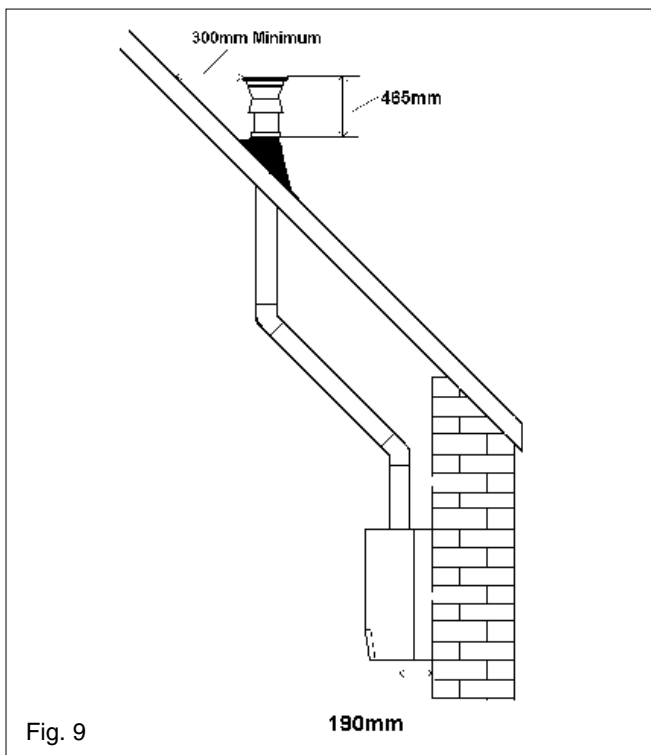

Fig. 9

IMPORTANT

The vertical flue terminal is 1.0 metre in length and cannot be cut; therefore it may be necessary to adjust the height of the appliance to suit or use a suitable extension.

Connect the vertical flue assembly to the boiler flue spigot using the 60mm & 100mm clips, gaskets, & screws (supplied), ensuring the correct seal is made. The flue support bracket (supplied with the vertical flue kit) can now be fitted.

If the vertical flue requires extension/s or additional bend/s, connect the required number of flue extensions or bends (up to the maximum equivalent flue length) between the boiler and vertical flue assembly (see fig. 8).

NOTE

When cutting an extension to the required length, you must ensure that the excess is cut from the plain end of the extension and that the inner (60mm) pipe is 7.5mm longer than outer (100mm) pipe (see fig. 8). Remove any burrs, and check that any seals are located properly.

You must ensure that the entire flue system is properly supported and connected.

4.5.3 TWIN FLUE SYSTEM

The Vokera twin flue system enables greater flue distances to be achieved (see 4.4.2) than that of a concentric flue system. It can be used for horizontal or vertical applications, however the twin flue system must be converted to the dedicated concentric flue kit for termination. It is essential that the installation of the twin flue system be carried out in strict accordance with these instructions.

GUIDANCE NOTES ON TWIN FLUE INSTALLATION

- The flue must have a fall back of 1° back to the appliance to allow any condensate that may form in the flue system to drain via the condensate drain. Consideration must also be given to the fact that there is the possibility of a small amount of condensate dripping from the terminal.

- Ensure that the entire flue system is adequately supported, use at least one bracket for each extension.
- The entire flue system must be adequately insulated to maintain heat within the flue system thereby reducing the possibility of condensate production.
- As the exhaust outlet pipe can reach very high temperatures it must be protected to prevent persons touching the hot surface.
- The condensate drain pipe must be connected in accordance with building regulations

Reduction for bends

Bend	Reduction in maximum flue length for each bend
45° bend	1.0 metre
90° bend	1.0 metre

Twin flue accessories

Part No.	Description	Length
0225805	Horizontal flue terminal	1.0 metre
0225810	Vertical flue terminal	1.0 metre
362	Twin adapter kit	N/A
0225770	Pitched roof flashing plate	N/A
0225765	Flat roof flashing plate	N/A
0225815	Condensate drain kit	N/A
0225820	0.25m extension (pair)	250mm
0225825	0.5m extension (pair)	500mm
0225830	1.0m extension (pair)	1000mm
0225835	2.0m extension (pair)	2000mm
0225840	45° bend (pair)	N/A
0225845	90° bend (pair)	N/A
0225850	Twin bracket (5)	N/A
0225855	Single bracket (5)	N/A

MOUNTING THE BOILER

The fixing holes for the wall-mounting bracket should now be drilled and plugged, an appropriate type and quantity of fixing should be used to ensure that the bracket is mounted securely. Once the bracket has been secured to the wall, mount the appliance onto the bracket.

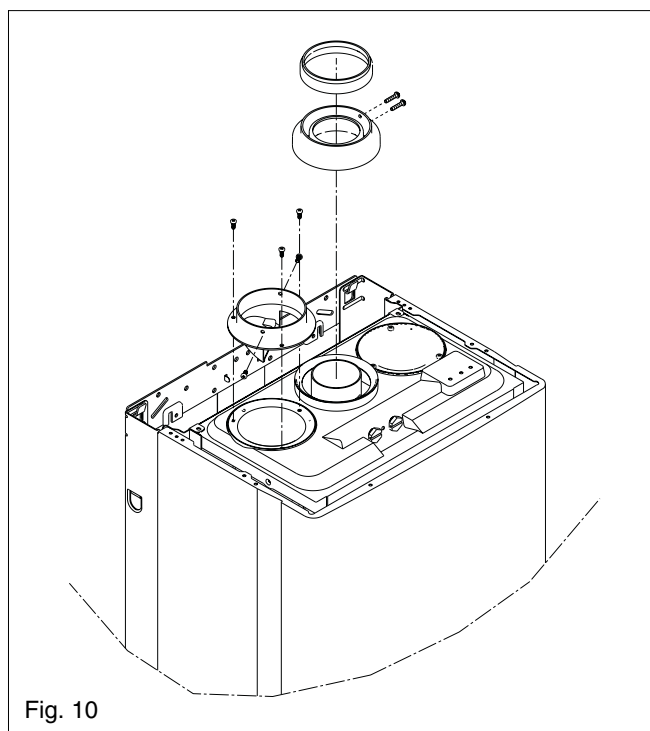
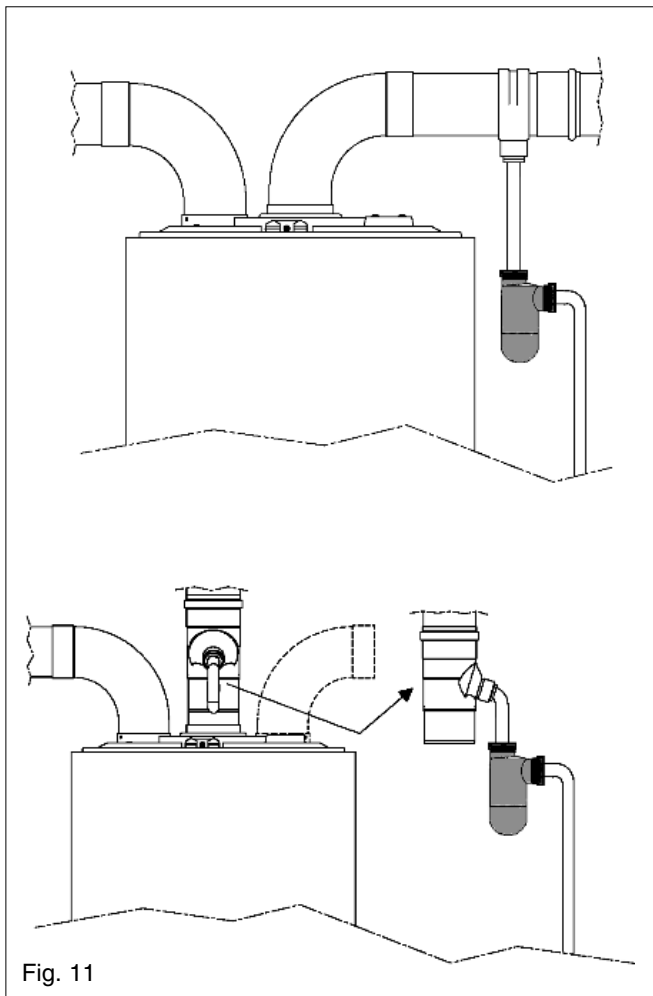

Fig. 10

4.5.3.1 INSTALLATION OF TWIN ADAPTOR KIT (fig. 10)

- Insert the exhaust connection manifold onto the appliance flue outlet.
- Place the silicone seal (supplied with twin adaptor kit) over the rim of the exhaust connection manifold.
- Remove the required blanking plate (located to the left and right of the appliance flue outlet) and – using the same screws – install the air baffle.
- Using the hole in the exhaust connection manifold as a guide, drill a 3mm hole in the appliance flue spigot and secure the exhaust manifold connection to the flue spigot using the screw provided.



4.5.3.2 INSTALLATION OF CONDENSATE DRAIN KIT (fig. 11)

The condensate drain kit must be fitted within 1 metre of the appliance flue outlet. It is recommended that the condensate drain kit should be fitted in the vertical plane, however it can be fitted horizontally with care.

- Fit the first bend to the condensate drain kit or exhaust connection manifold by firmly pushing in to position.
- Using the two holes in the exhaust connection manifold as a guide, drill a 3mm hole in each and secure using the screws provided.

- Connect the air inlet pipe to the air baffle as above.
- Prime the condensate trap with clean water prior to commissioning the appliance.
- The twin flue pipes extensions and accessories can now be installed by pushing together (the plain end of each extension or bend should be pushed approximately 50mm into the female socket of the previous piece).

4.5.3.3 HORIZONTAL TERMINATION (See fig. 12)

The twin flue system must be converted to the dedicated concentric flue kit for termination.

- The horizontal terminal is supplied with a built-in converter box and cannot be shortened.
- A 130mm hole is required for the passage of the concentric terminal through the wall.
- The air inlet pipe must always be level with or below, that of the exhaust pipe.

Depending on site conditions it may be preferable to install the terminal assembly prior to fitting the twin flue pipes.

Mark and drill a 130mm hole for the passage of the horizontal flue terminal, ensuring that there is a 1° fall back to the boiler (17mm per 1000mm). Insert the terminal assembly into the flue hole.

Push-fit the twin flue pipes onto the concentric to twin converter box ensuring that the exhaust pipe connects to the exhaust connection on the concentric to twin converter.

If necessary cut the plain ends (male) of the twin flue pipes to allow connection to the concentric to twin converter.

NOTE; before cutting twin flue pipes ensure allowances have been made for connection onto the previous piece and onto the concentric to twin converter. The last twin flue pipes must be pushed 50mm onto the male spigots of the concentric to twin converter.

NOTE;

You must ensure that the entire flue system is properly supported and connected.

Seal the flue terminal assembly to the wall using cement or a suitable alternative that will provide satisfactory weatherproofing. The interior and exterior trim can now be fitted.

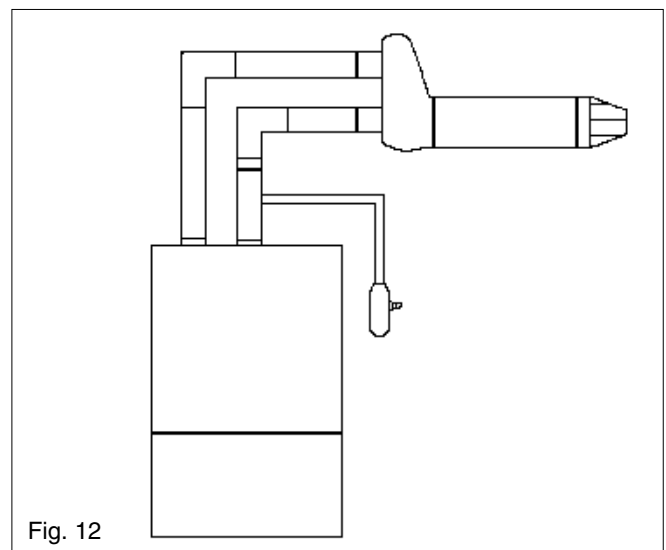

4.5.3.4 VERTICAL TERMINATION (See fig. 13)

The twin flue system must be converted to the dedicated concentric flue kit for termination.

- The vertical terminal is supplied with a built-in converter box and cannot be shortened.
- A 130mm hole is required for the passage of the concentric terminal through the ceiling and/or roof.

Depending on site conditions it may be preferable to install the terminal assembly prior to fitting the twin flue pipes.

Fit the appropriate flashing plate to the roof and insert the vertical flue terminal through the flashing plate from the outside, ensuring that the collar on the flue terminal fits over the flashing.

Push-fit the twin flue pipes onto the concentric to twin converter ensuring that the exhaust pipe connects to the exhaust connection on the concentric to twin converter.

If necessary cut the plain ends (male) of the twin flue pipes to allow connection to the concentric to twin converter.

NOTE

- Before cutting twin flue pipes ensure allowances have been made for connection onto the previous piece and onto the concentric to twin converter. The last twin flue pipes must be pushed 50mm onto the male spigots of the concentric to twin converter.
- You must ensure that the entire flue system is properly supported and connected.
- Ensure that any horizontal sections of pipe have a 1° fall towards the appliance (17mm per 1000mm).

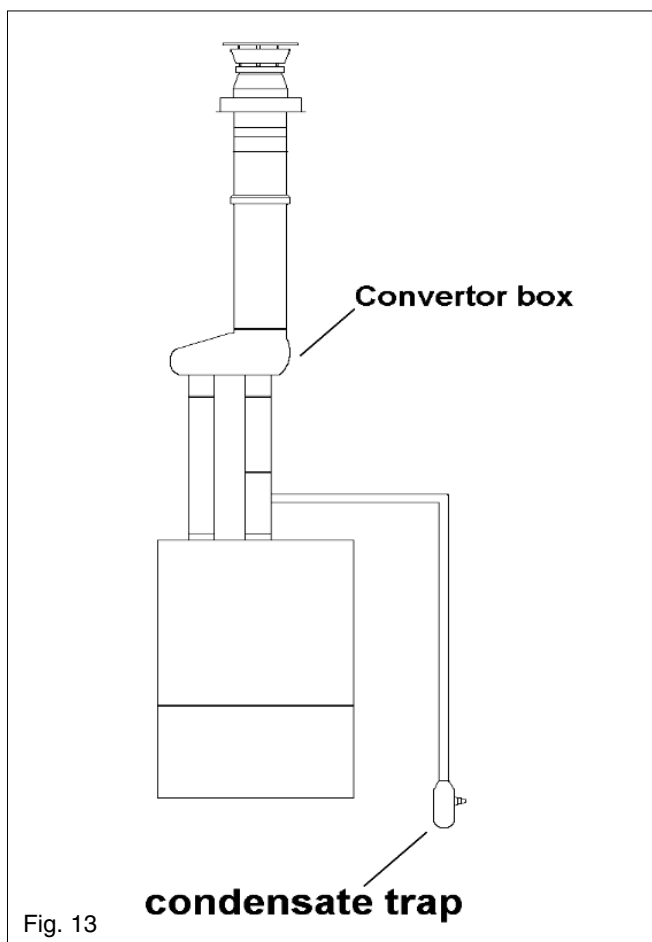

4.6 CONNECTING THE GAS AND WATER

The appliance is supplied with a fixing jig that includes service valves (fig. 14). The service valves are of the compression type. The accessories pack contains sealing washers etc, for use with the service valves.

When connecting pipe work to the valves, tighten the compression end first then insert the sealing washers before tightening the valve to the appliance.

NOTE

It will be necessary to hold the valve with one spanner whilst tightening with another.

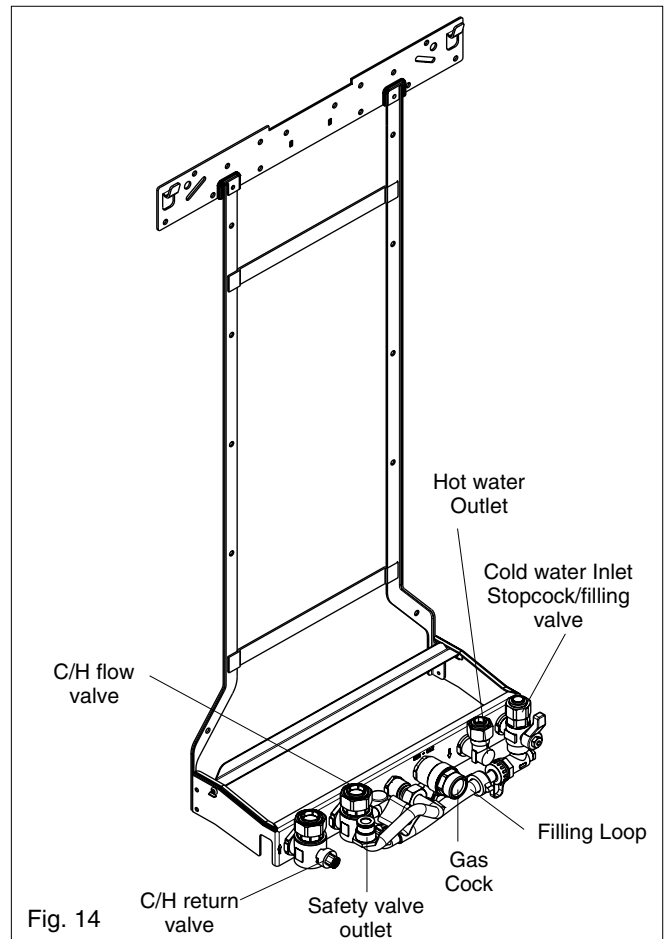

4.6.1 GAS (fig. 6 & 14)

The appliance is supplied with a 15mm service valve, connect a 15mm pipe to the inlet of the valve and tighten both nuts.

NOTE

It will be necessary to calculate the diameter of the gas supply pipe to ensure the appliance has an adequate supply of gas.

4.6.2 FLOW & RETURN (fig. 6 & 14)

The appliance is supplied with 22mm service valves for the flow and return connections, connect a 22mm pipe to the inlet of each valve and tighten both nuts.

NOTE

Depending on system requirements, it may necessary to increase the size of the flow & return pipe work after the service valve connections.

4.6.3 COLD WATER INLET (fig. 6 & 14)

The appliance is supplied with a 15mm combined stopcock and double check-valve, connect a 15mm pipe to the inlet of the stopcock and tighten both nuts.

4.6.4 HOT WATER OUTLET (fig. 6 & 14)

The appliance is supplied with a 15mm outlet connection, connect a 15mm pipe to the outlet connection and tighten both nuts.

4.6.5 SAFETY VALVE (fig. 6 & 14)

Connect the safety valve connection pipe between the safety valve outlet and the fixing jig. Connect a discharge pipe to the fixing jig connection and tighten. The discharge pipe must have a continuous fall away from the appliance to outside and allow any water to drain away thereby eliminating the possibility of freezing. The discharge pipe must terminate in a position where any water – possibly boiling – discharges safely without causing damage or injury, but is still visible.

4.7 ELECTRICAL CONNECTIONS

The electrical supply must be as specified in section 3.7. A qualified electrician should connect the electrical supply to the appliance. If controls – external to the appliance – are required, a competent person must undertake the design of any external electrical circuits, please refer to section 8 for detailed instructions. ANY EXTERNAL CONTROL OR WIRING MUST BE SERVED FROM THE SAME ISOLATOR AS THAT OF THE APPLIANCE. The supply cable from the isolator to the appliance must be 3-core flexible sized 0.75mm to BS 6500 or equivalent. Wiring to the appliance must be rated for operation in contact with surfaces up to 90°C.

4.7.1 CASING REMOVAL

To gain internal access to the appliance you must first remove the casing, proceed as outlined below:

- Press the controls cover to release the controls cover catch
- Locate and unscrew the 2 screws that secure the controls fascia to the appliance casing (see fig 15).
- Gently lower the control fascia until it rests.
- Remove the 2 screws located at the Left & Right of the underside of the casing.
- Lift the casing upward to disengage it from the top locating hooks and then remove.
- Store the casing and screws safely until required. Re-fit in the reverse order.

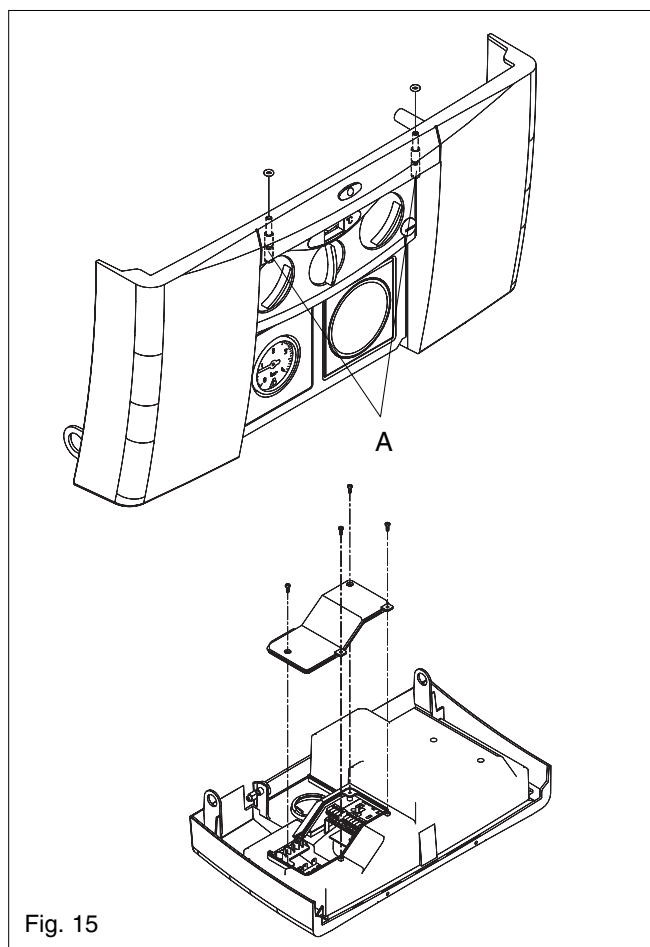

Fig. 15

4.7.2 APPLIANCE TERMINAL BLOCK

The appliance terminal block is located on the left side of the control fascia (see fig. 15). Locate and remove the screws securing the terminal block cover.

NOTE

The appliance comes with a factory fitted link to allow basic operation of the boiler via the mode selector switch. If it is anticipated that external controls will be required please refer to the wiring diagrams in section 8 for more detailed information.

4.7.3 CONNECTING THE MAINS (230V) INPUT (see fig. 16)

Remove the terminal block cover as described in 4.7.2. Pass the cable through the cable anchorage point. At plug M16 on the appliance control PCB there are 7 terminals from Front to Back they are:

1. NEUTRAL
2. NEUTRAL (supply for clock)
3. LIVE
4. LIVE (supply to clock)
5. TA
6. TA
7. (Spare)

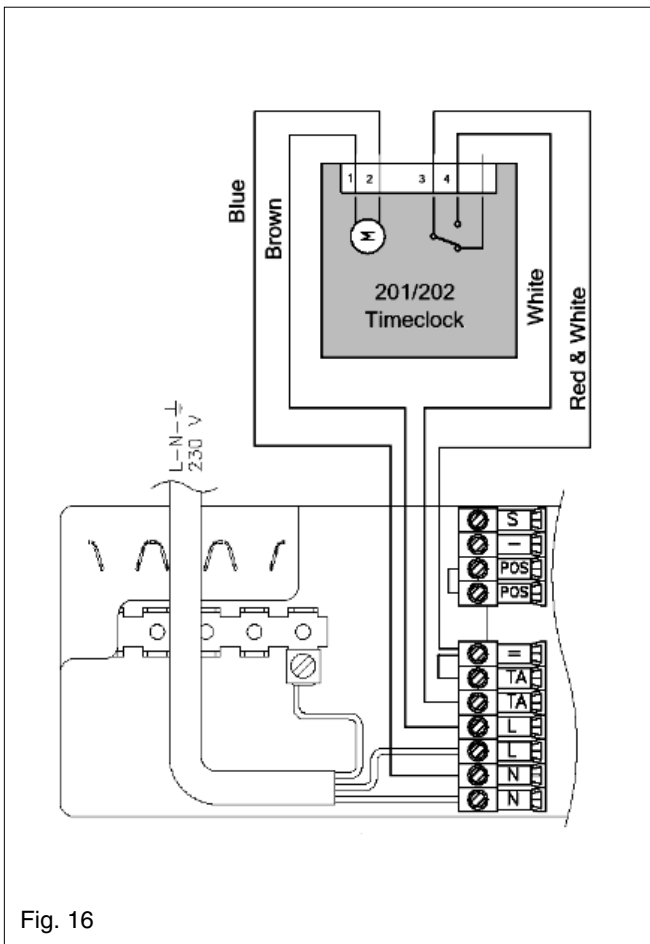

Fig. 16

Connect the supply cable wires (LIVE, and NEUTRAL) to their corresponding terminals on the appliance terminal block. Connect the EARTH wire to the EARTH block (see fig. 16) ensuring that it's left slightly longer than the others, this will prevent strain on the EARTH wire should the cable become taut.

Do not remove the link wire (between TA & Spare) unless additional external controls are to be fitted (see section 8).

4.7.4 CONNECTING THE VOKERA TIME CLOCK (part no. 201 & 202)

The appliance is supplied with a clock connector plug that is connected to plug M16 on the appliance terminal block. The clock connector plug is for use with the clock harness that is included in the accessory pack and facilitates an easy connection to the optional Vokera time clock.

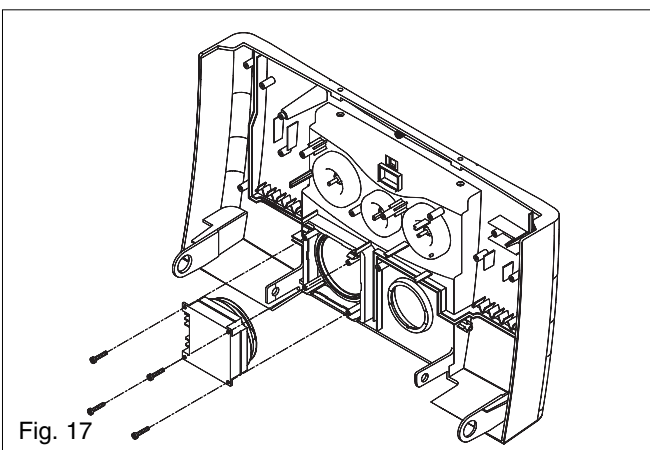

Fig. 17

To fit the Vokera time clock:

- Remove the appliance PCB cover.
- Remove and discard the wiring harness supplied with the clock.
- Using the clock wiring harness supplied in the accessory pack, connect the 4-wires to the clock as shown in fig. 16.
- Remove the clock aperture plate from the appliance.
- Remove the push-out blanking disc from the clock aperture plate (fig. 17).
- Secure the clock to the aperture plate using the screws provided with the clock (fig. 17).
- Refit the clock aperture plate ensuring the clock is positioned the correct way up.
- Remove the Red link-wire plug from the appliance clock connector plug.
- Connect the clock wiring harness to the clock connector plug.
- Re-fit the appliance PCB cover and terminal cover.

The securing screw on the cable anchorage should now be tightened. This must be done before the control fascia is re-fitted in the upright position. The appliance casing and screws can now be re-fitted.

SECTION 5 COMMISSIONING

5.1 GAS SUPPLY INSTALLATION

Inspect the entire installation including the gas meter, test for soundness and purge. Refer to BS 6891 for specific instruction.

5.2 THE HEATING SYSTEM

The appliance contains components that may become damaged or rendered inoperable by oils and/or debris that are residual from the installation of the system, consequently it is essential that the system be flushed in accordance with the following instructions.

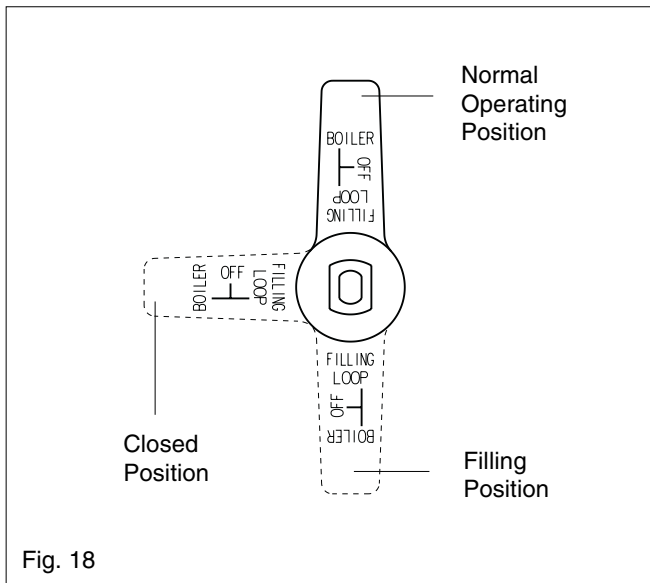

Fig. 18

5.3 INITIAL FILLING OF THE SYSTEM

Ensure both flow and return service valves are open, remove appliance casing as described in 4.7.1, identify the automatic air release valve and loosen the dust cap by turning the cap anti-clockwise one full turn. **IMPORTANT, THERE ARE NO MANUAL AIR RELEASE VALVES LOCATED ON THE APPLIANCE.** Ensure all manual air release valves located on the heating system are closed. Connect the filling loop as shown in fig. 14, slowly proceed to fill the system by firstly opening the inlet valve connected to the flow valve, and then turning the lever on the combined stopcock and check valve, to the filling position (see Fig. 18). As water enters the system the pressure gauge will begin to rise. Once the gauge has reached 1 BAR close both valves and begin venting all manual air release valves, starting at the lowest first. It may be necessary to go back and top-up the pressure until the entire system has been filled. Inspect the system for water soundness, rectifying any leaks.

5.4 INITIAL FLUSHING

The whole of the heating system must be flushed both cold and hot as detailed in 5.8. Open all radiator or heating valves and the appliance flow & return service valves. Drain the boiler and system from the lowest points. Open the drain valve

full bore to remove any installation debris from the boiler prior to lighting. Refill the boiler and heating system as described in 5.3.

5.5 FILLING THE HOT WATER SYSTEM

Close all hot water outlets, turn appliance stopcock to the normal operating position (fig. 18), slowly open each outlet until air has been expelled and clear water is discharged. Check pipe-work etc. for water soundness.

5.6 PRE-OPERATION CHECKS

Before attempting the initial lighting of the appliance, the following checks must be carried out:

- Ensure all gas service valves from the meter to the appliance are open and the supply pipe has been properly purged.
- Ensure the proper electrical checks have been carried out, (see 7.7) particularly continuity, polarity, and resistance to earth.
- Ensure the 3 AMP fuse – supplied with the appliance – has been fitted.
- Ensure the system has been filled, vented, and the pressure set to 1 BAR.
- Ensure the flue system has been fitted properly and in accordance with the instructions.
- Ensure all appliance service valves are open.

5.7 INITIAL LIGHTING

Ensure the electrical supply to the appliance is switched on. Move the selector switch to the Heating & Hot Water position, ensure the time clock is switched to an 'ON' position and ensure any other external controls are also calling for heat.

The appliance will now operate in the pre-heat mode as described in 1.2. Once the pre-heat function has been completed, the appliance will operate in the central heating mode as described in 1.3. Should the appliance fail to ignite, refer to 5.6 and/or section 7 (faultfinding).

5.7.1 CHECKING THE BURNER PRESSURE

Although the burner pressure is factory set, it is necessary to check it during commissioning. Isolate the appliance from the electrical supply and attach a suitable manometer to the gas valve outlet test-point (see fig. 19). Light the boiler as described in 5.7, turn the Hot Water temperature selector to maximum, and open fully a DHW outlet (preferably the bath), allowing the appliance to stabilise. Compare the reading on the manometer with the value described in 2.3. If adjustment is required, follow the detailed instructions in section 7 (7.3).

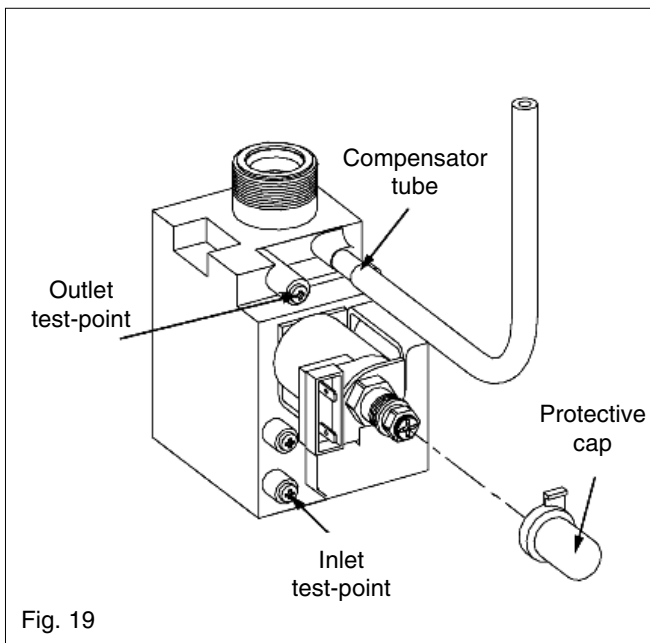

Fig. 19

Once the burner pressure has been checked, close the DHW outlet, isolate the appliance from the electrical supply, remove the manometer, and tighten the gas valve outlet test nipple.

5.8 FINAL FLUSHING OF THE HEATING SYSTEM

The system shall be flushed in accordance with BS 7593. If a cleanser is to be used, it shall be from a reputable manufacturer* and shall be administered in strict accordance with the manufacturers instructions.

*Both Sentinel and Fernox manufacture products that have proved suitable for use with Vokera appliances. Vokera Ltd. cannot comment on the suitability of any other such product with our appliances.

5.8.1 INHIBITORS

See Section 3 "general requirements"

5.9 SETTING THE BOILER OPERATING TEMPERATURE

The flow outlet temperature can be adjusted between 40°C - 80°C via the Heating thermostat knob (see fig.1).

5.9.1 SETTING THE DOMESTIC HOT WATER TEMPERATURE

The DHW outlet temperature can be adjusted between 40°C - 65°C via the Hot Water thermostat knob (see fig.1).

5.10 SETTING THE SYSTEM DESIGN PRESSURE

The design pressure should be a minimum of 1 BAR and a maximum of 1.5 BAR.

The actual reading should ideally be 1BAR plus the equivalent height in metres (0.1 BAR = 1 metre) to the highest point in the system above the base of the appliance (up to the maximum of 1.5 BAR total).

N.B. The safety valve is set to lift at 3 BAR/30 metres/45 psig.

To lower the system pressure to the required value, pull lever on head of safety valve to release water until the required figure registers on the pressure gauge (see fig. 1).

5.11 REGULATING THE HOT WATER

The appliance is fitted with a flow rate restrictor that limits the maximum flow rate that can be drawn through the appliance.

Linea 726

8-litre (White)	9-litre (Orange)	10-litre (Blue)
Spare	Fitted	Spare

Linea 730

9-litre (Orange)	10-litre (Blue)	11-litre (Beige)
Spare	Fitted	Spare

Linea 735

11-litre (Beige)	12-litre (Red)	13-litre (Olive)
Spare	Fitted	Spare

The restrictor eliminates the need to manually adjust the DHW flow rate. However if it is felt necessary to further increase or decrease the available flow rate, spare restrictors are included in the accessory pack.

The spare flow rate restrictors can be fitted to either increase or decrease the maximum flow rate. The tables above denote the size of restrictor fitted and the spare restrictors supplied in the accessory pack. Each restrictor is colour-coded to enable identification.

5.11.1 CHANGING THE FLOW RESTRICTOR

Refer to 6.19 for detailed instruction on changing the flow restrictor.

5.11.2 REGULATING THE CENTRAL HEATING SYSTEM

Fully open all radiator and circuit valves and run the appliance for both heating and hot water until heated water is circulating. If conditions are warm remove any thermostatic heads. Adjust radiator return valves and any branch circuit return valves until the individual return temperatures are correct and are approximately equal.

5.12 FINAL CHECKS

- ENSURE ALL TEST NIPPLES ON THE APPLIANCE GAS VALVE HAVE BEEN TIGHTENED AND CHECKED FOR SOUNDNESS.
- ENSURE THE APPLIANCE FLUE SYSTEM IS FITTED CORRECTLY AND IS PROPERLY SECURED.
- ENSURE ALL PIPE WORK IS RE-CHECKED FOR SOUNDNESS.
- RE-FIT APPLIANCE CASING.
- COMPLETE APPLIANCE LOGBOOK.

Complete details of the boiler, controls, installation, and commissioning in the logbook supplied with the boiler. This is an important document, which must be correctly completed and handed to the user. Failure to install and commission the appliance to the manufacturers instructions may invalidate the warranty.

5.13 INSTRUCTING THE USER

Hand over all documentation supplied with this appliance – including these instructions – and explain the importance of keeping them in a safe place.

Explain to the user how to isolate the appliance from the gas, water, and electricity supplies, and the locations of all drain points.

Show the user how to operate the appliance and any associated controls correctly.

Show the user the location of the filling valve and how to top-up the system pressure correctly, and show the location of all manual air release points.

Explain to the user how to turn off the appliance for both long and short periods and advise on the necessary precautions to prevent frost damage.

Explain to the user that for continued safe and efficient operation, the appliance must be serviced annually by a competent person.

SECTION 6 SERVICING

6.1 GENERAL

To ensure the continued safe and efficient operation of the appliance, it is recommended that it is checked and serviced at regular intervals.

To ensure correct and safe operation of the appliance, it is essential that any worn or failed component be replaced only with a genuine Vokera spare part.

The frequency of servicing will depend upon the particular installation conditions, but in general, once per year should be adequate.

It is the law that any servicing work is carried out by competent person such as a Vokera engineer, an approved service agent, British Gas, or other CORGI registered personnel.

The following instructions apply to the appliance and its controls, but it should be remembered that the central heating and the domestic hot water systems would also require attention from time to time.

6.2 ROUTINE ANNUAL SERVICING

Check the operation of the appliance and ensure it functions as described in section 7. Compare the performance of the appliance with its design specification. The cause of any noticeable deterioration should be identified and rectified without delay.

Thoroughly inspect the appliance for signs of damage or deterioration especially the flue system and the electrical apparatus.

Check and adjust – if necessary – all burner pressure settings. (See 7.3)

Check and adjust – if necessary – the system design pressure. (See 5.10)

Carry out an analysis of the flue gases (see 7.4), and visually check the condition of the entire flue assembly. Compare the results with the appliance design specification. Any deterioration in

performance must be identified and rectified without delay.

Ensure both flue venturis are clean and free from any debris or obstruction.

Ensure both the burner and heat exchanger are clean and free from any debris or obstruction.

6.3 REPLACEMENT OF COMPONENTS

Although it is anticipated that this appliance will give years of reliable, trouble free service, the life span of components will be determined by factors such as operating conditions and usage. Should the appliance develop a fault, the fault finding section will assist in determining which component is malfunctioning.

6.4 COMPONENT REMOVAL PROCEDURE

To remove a component, access to the interior of the appliance is essential. Isolate the appliance from the electrical supply and remove the fuse. And when necessary, close all service valves on the appliance, remove the appliance casing as described in section 4.7.1, and drain the water content from the appliance via the safety valve. Ensure some water absorbent cloths are available to catch any residual water that may drip from the appliance or removed component. Undertake a complete commissioning check as detailed in section 5, after replacing any component. **ALWAYS TEST FOR GAS SOUNDNESS IF ANY GAS CARRYING COMPONENTS HAVE BEEN REMOVED OR DISTURBED.**

6.5 PUMP ASSEMBLY fig. 20

Carry out component removal procedure as described in 6.4.

Disconnect and remove the ancillary items (3,4,5,6,7) from the pump assembly. Slacken and remove the securing screw (8) from the heating manifold. Disconnect the electrical cover & lead (1,2). The pump assembly can now be removed from the heating manifold. Replace in the reverse order.

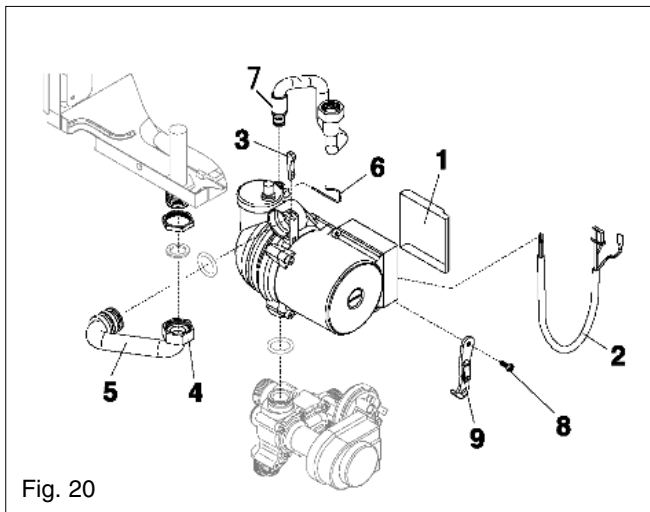

Fig. 20

6.6 SAFETY VALVE fig. 21

Carry out component removal procedure as described in 6.4.

Disconnect the outlet pipe from the safety valve, remove safety valve locking screw (1) from the heating manifold. Replace in the reverse order.

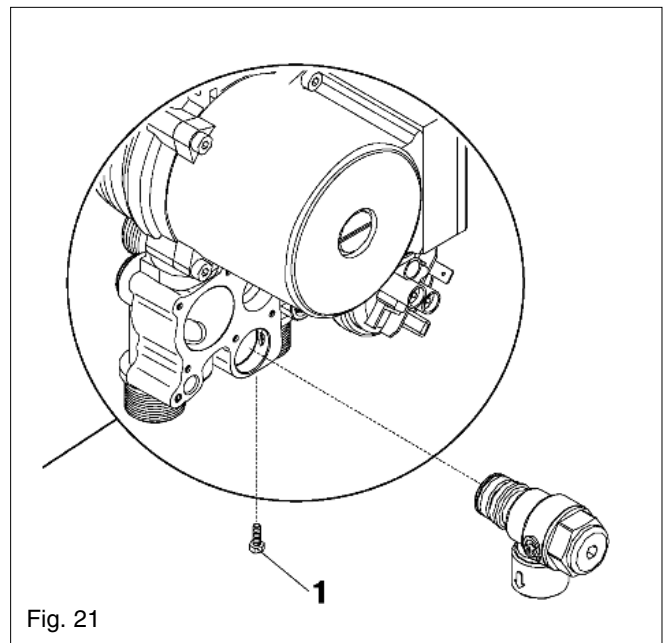

Fig. 21

6.7 AUTOMATIC AIR RELEASE VALVE fig. 20 (AAV)

Carry out component removal procedure as described in 6.4.

Using a suitable pair of pump pliers, unscrew the AAV from the rear of the pump assembly. Replace in the reverse order.

6.8 WATER PRESSURE SWITCH fig. 22

Carry out component removal procedure as described in 6.4.

Remove locking screw (1) and the water pressure switch from the heating manifold, and – after taking note of the electrical connections – disconnect the wiring. Replace in the reverse order.

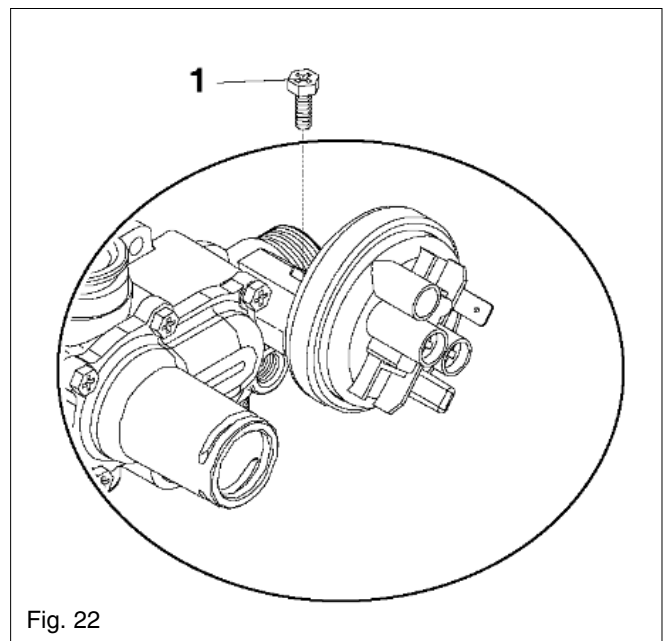

Fig. 22

6.9 PRESSURE GAUGE fig. 23

Carry out component removal procedure as described in 6.4.

Remove pressure gauge locking screw (1), located on pump base, and withdraw the pressure gauge pipe (2), locate the spring tabs on the pressure gauge body, push and hold tabs in, to enable extraction of the gauge from its location. Replace in the reverse order.

6.10 PRIMARY THERMISTOR fig. 24

Carry out component removal procedure as described in 6.4.

Unclip and remove the air chamber cover, and remove the right side air baffle.

Disconnect thermistor electrical plug. Using a 13mm spanner slacken and remove the thermistor and sealing washer (1,2) from the main heat exchanger. Replace in the reverse order.

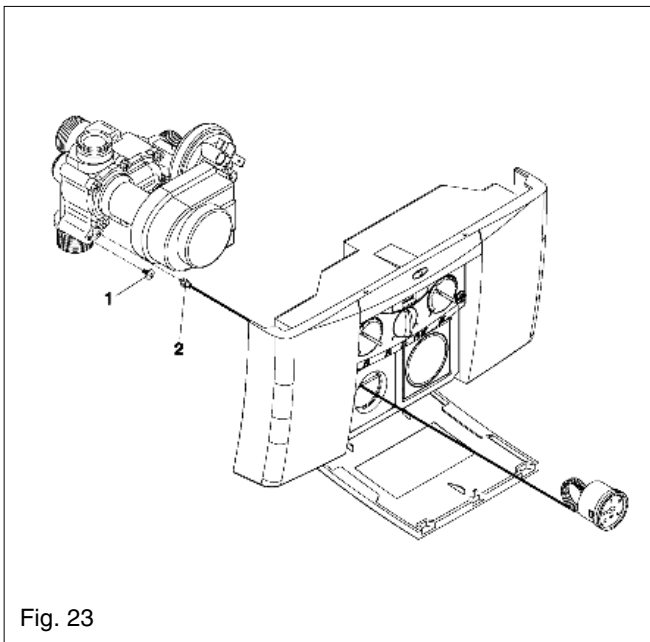

Fig. 23

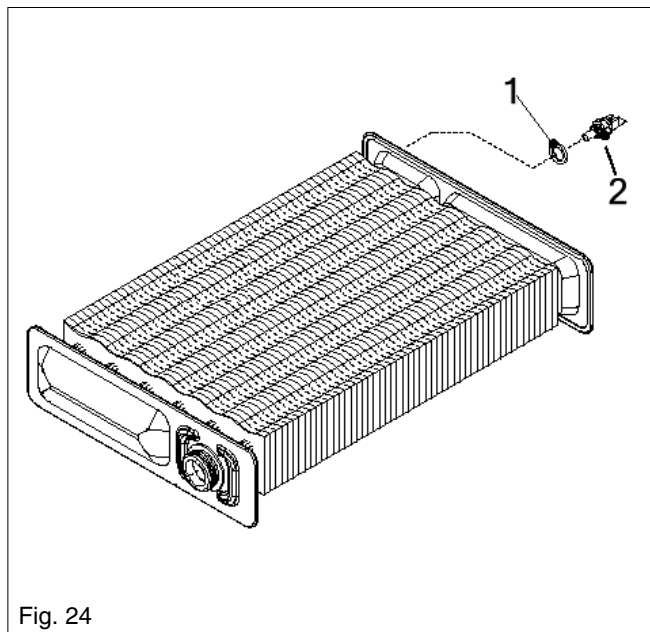

Fig. 24

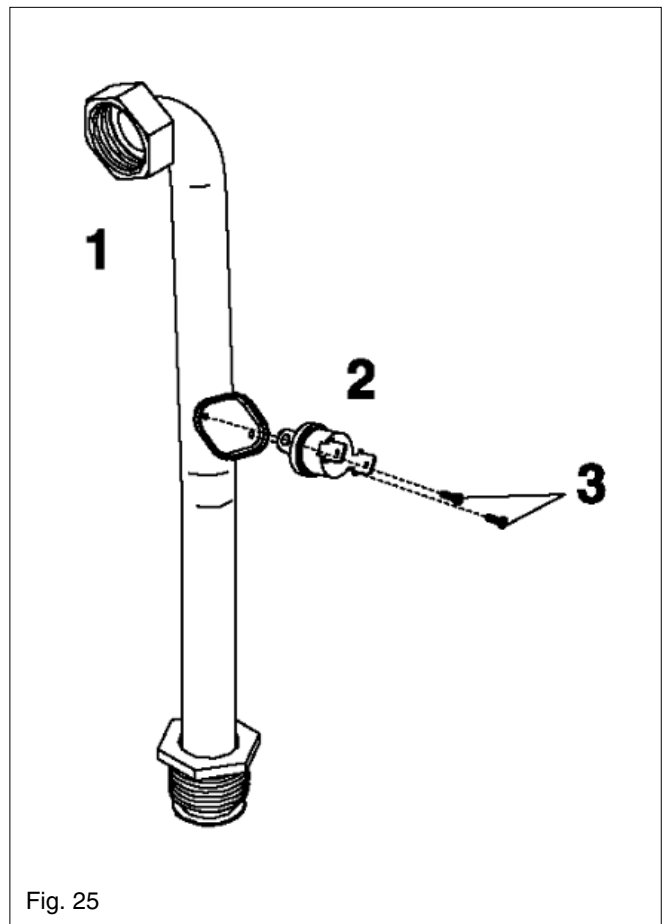

Fig. 25

6.11 HIGH LIMIT THERMOSTAT fig. 25

Carry out component removal procedure as described in 6.4.

Unclip and remove the air chamber cover.

Pull off electrical connections from the high limit thermostat (2), slacken and remove retaining screws (3). Replace in reverse order.

6.12 PRINTED CIRCUIT BOARD fig. 26

Carry out component removal procedure as described in 6.4.

Locate and remove the screws (1) which secure the PCB cover & terminal cover, then remove cover, after carefully taking note of all wiring connections, disconnect all wiring from the PCB, locate and remove the PCB securing screws (2,3,), remove the required PCB (4,5,6). Replace in the reverse order.

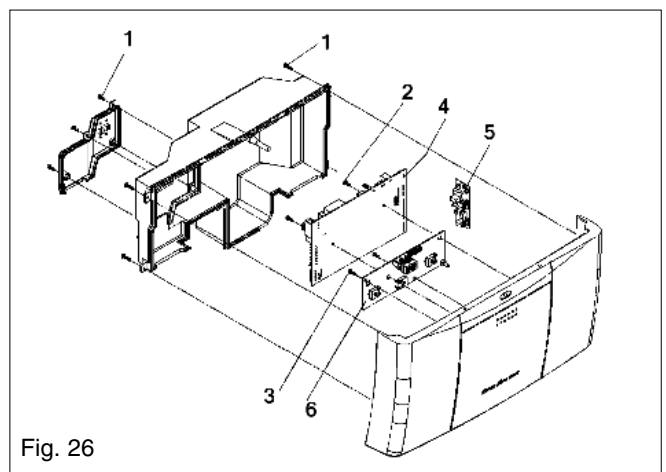

Fig. 26

NOTE

Ensure that any replacement PCB has the correct 'Jumper Tag' configuration (see section 8).

6.13 GAS VALVE fig. 27

Carry out component removal procedure as described in 6.4.

The gas valve must be changed as complete unit. Disconnect the electrical plug and leads from the gas valve. Slacken and unscrew gas valve inlet and outlet connections (3). **Please note**, the sealing washers (2) must be discarded and replaced with new sealing washers (2). Locate and remove gas valve retaining screws on the underside of the boiler if required, the gas valve can now be removed. Replace in the reverse order. Check and adjust burner pressure settings. **WARNING, A GAS SOUNDNESS CHECK MUST BE CARRIED OUT.**

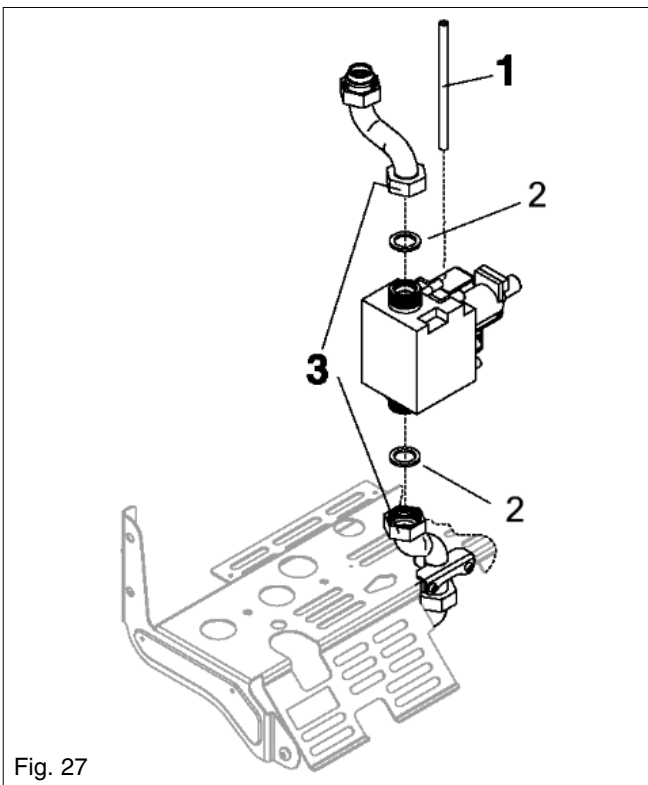

Fig. 27

6.14 INTEGRAL TIME SWITCH (if fitted)

Carry out component removal procedure as described in 6.4.

Locate and remove the terminal cover and securing screws (2), locate and remove the time clock retaining screws, remove time clock. Disconnect wiring after carefully taking note of all electrical connections. Replace in the reverse order.

6.15 ELECTRODE, BURNER THERMOSTAT, BURNER, & INJECTORS fig. 28

Carry out component removal procedure as described in 6.4.

Unclip and remove the air chamber cover (2). Locate and remove the screws securing the front combustion cover (3), pull the cover towards you before lifting and disengaging. Disconnect the

electrode lead and burner thermostat from their respective connectors. Ease the electrode sealing grommet from its seating (4). Remove the retaining screw for the burner thermostat and remove the thermostat

FIG. 29, Locate and remove the four screws which secure the burner in position (1), gently ease the burner out of its location. Once the burner has been removed, the electrode retaining screw can be removed. Locate the burner injectors (2) and remove (if necessary). Replace in the reverse order. Please note, the injector sealing washers (3) must be replaced if the injectors have been removed, ensure all seals are in good condition, taking care to ensure they are replaced correctly.

Replace in the reverse order.

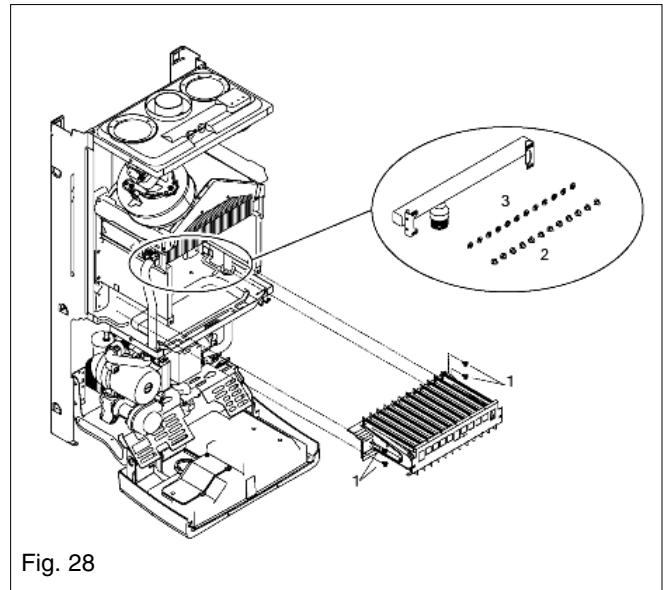
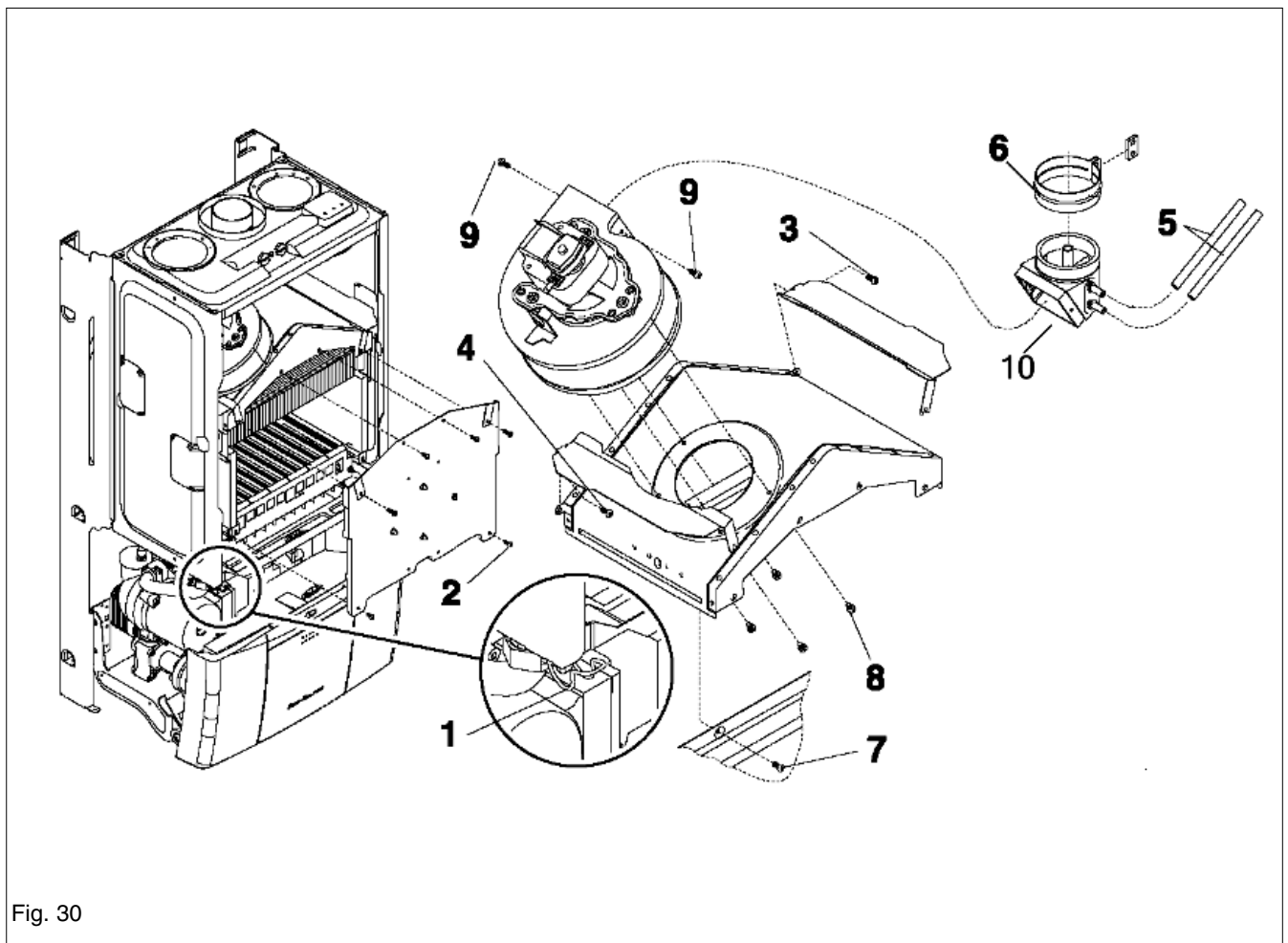
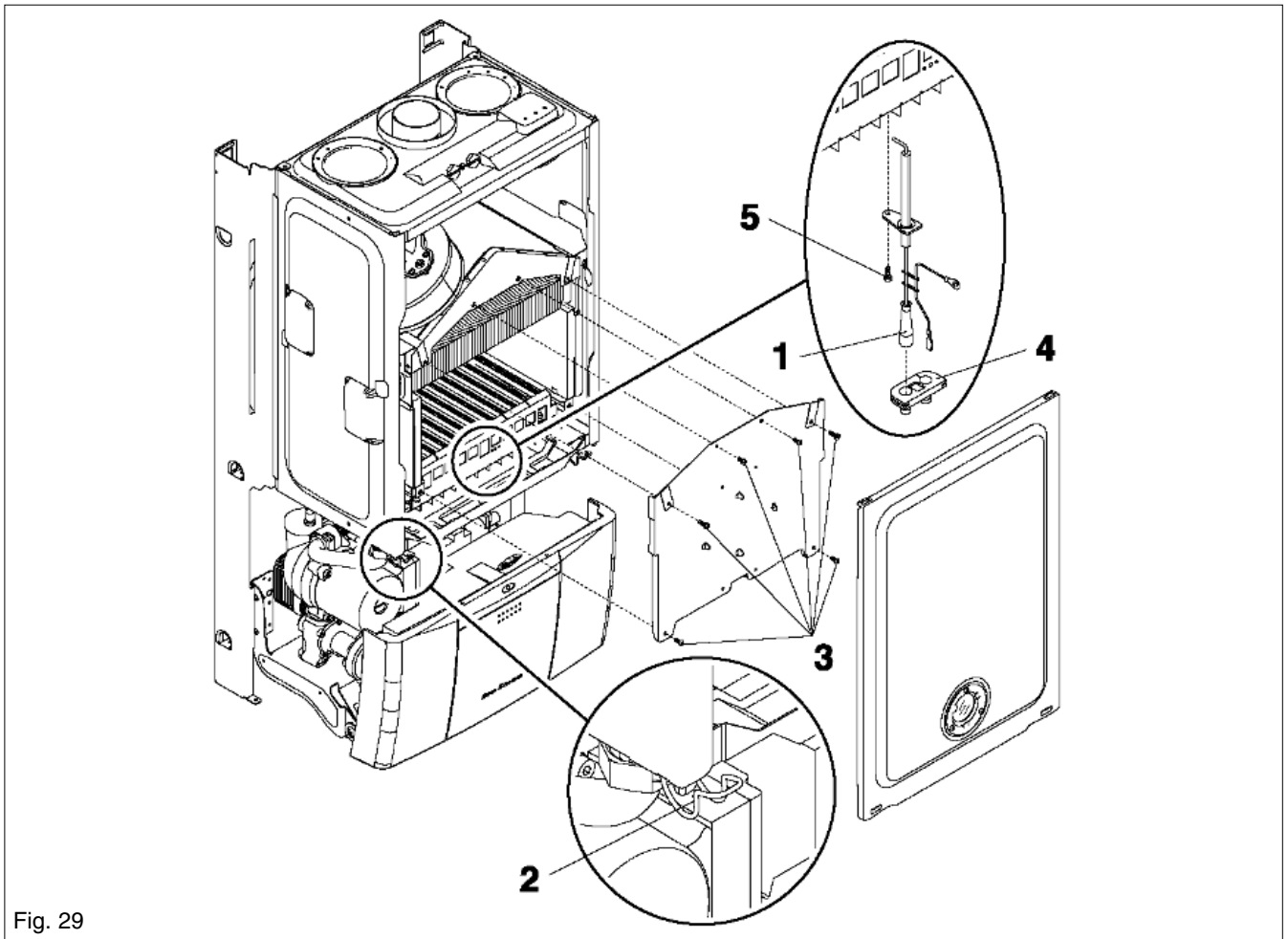

Fig. 28

6.16 FLUE FAN fig. 30

Carry out component removal procedure as described in 6.4.

Unclip and remove the air chamber cover, gently pull the cover towards you before lifting and disengaging. Locate and remove the six screws that secure the front combustion cover (2), then remove the cover. Disconnect the electrical connections and silicone tubes (5) attached to the fan, noting their positions. Locate and remove the three screws that secure the flue hood and air baffles (3,4,7), disconnect the flue clip (6) from the fan-flue elbow, ease the fan & flue hood assembly from its location. Locate and remove the four screws (8) that secure the fan to the flue hood. Remove the fan to flue elbow (10). Replace in the reverse order. Ensure all seals are in good condition, taking care to ensure they are replaced correctly.



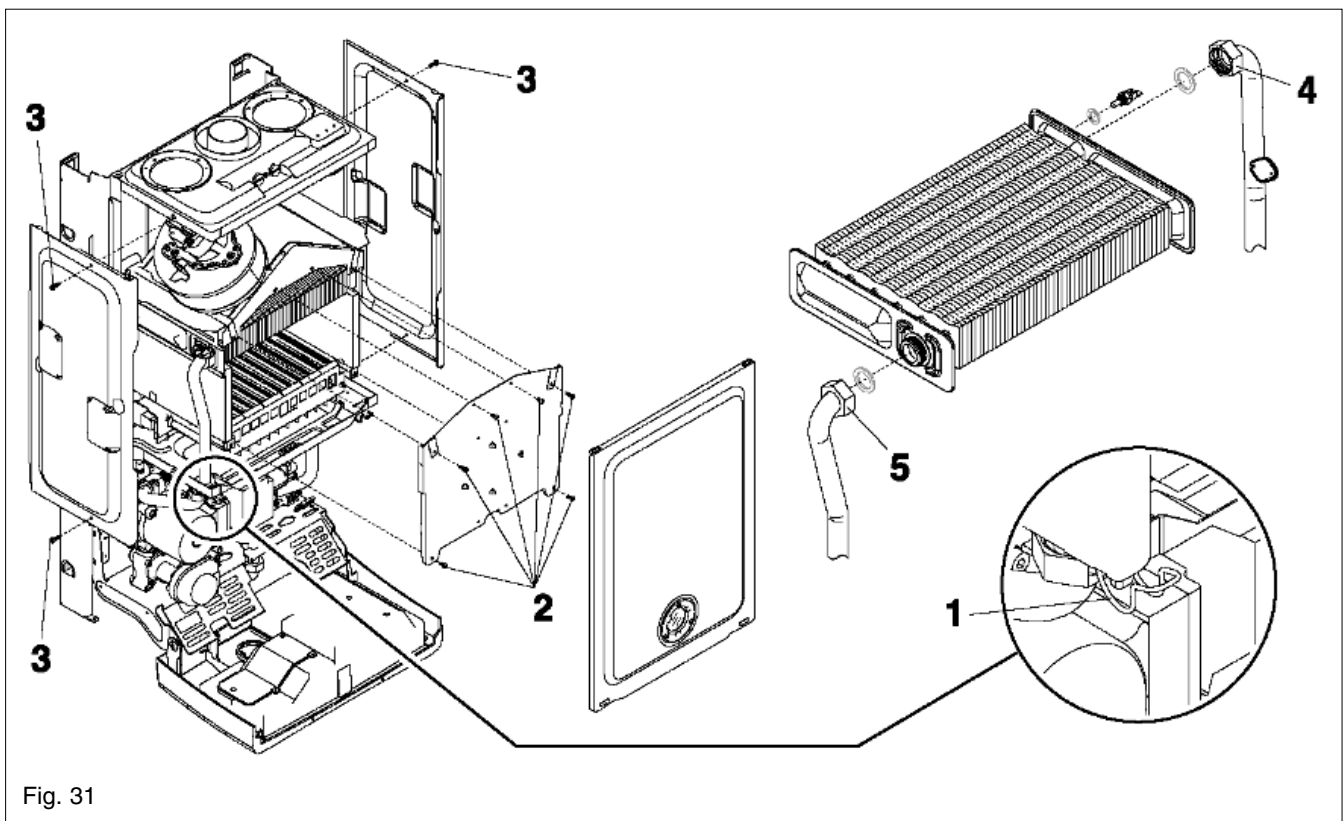

Fig. 31

6.17 MAIN HEAT EXCHANGER fig. 31

Carry out component removal procedure as described in 6.4.

Unclip and remove the air chamber cover, gently pull the cover towards you before lifting and disengaging. Locate and remove the six screws (2) that secure the front combustion cover, then remove the cover. Remove the air chamber side panels if necessary by unscrewing the securing screws (3). Disconnect the flow and return connections (4,5) on the heat exchanger. The heat exchanger can now be withdrawn from the appliance. Replace in the reverse order. Ensure all seals are in good condition, taking care to ensure they are replaced correctly.

6.18 AIR PRESSURE SWITCH fig. 32

Carry out component removal procedure as described in 6.4.

Unclip and remove the air chamber cover, gently pull the cover towards you before lifting and disengaging. Locate and remove the two screws (2) holding the air pressure switch to the air chamber. Disconnect the electrical connections and silicone tubes (1) attached to the air pressure switch, noting their positions. Replace in the reverse order. Ensure all seals are in good condition, taking care to ensure they are replaced correctly.

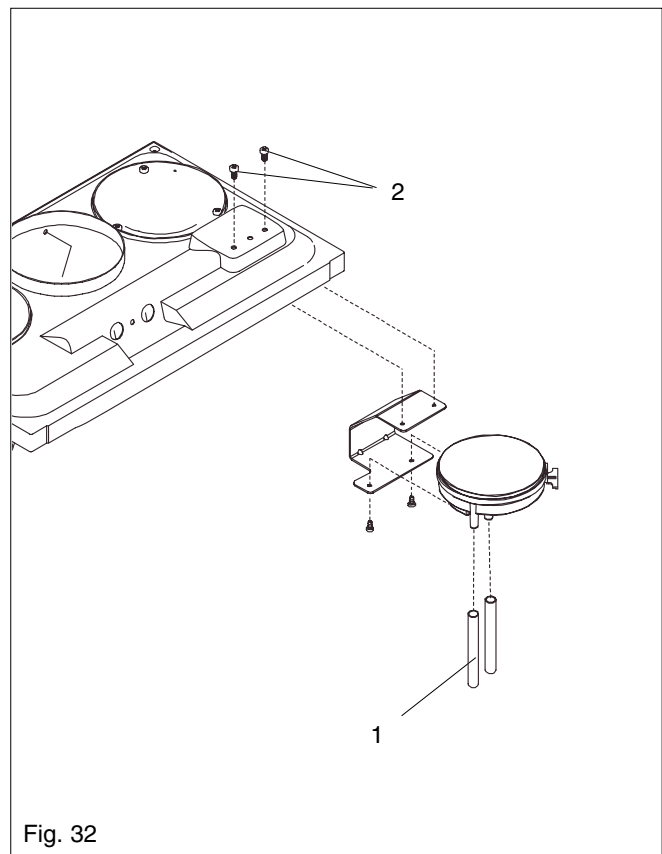

Fig. 32

6.19 FLOW RESTRICTOR fig. 33

Carry out the component removal procedure as described in 6.4.

Slacken the cold water inlet pipe (1) at the DHW flow switch. Disconnect the cold-water inlet pipe (2) from the DHW heat exchanger and move it to the side. Using a small screwdriver, gently ease the flow restrictor (6) from its seating. Replace in the reverse order. Ensure all seals are in good condition, taking care to ensure they are replaced correctly.

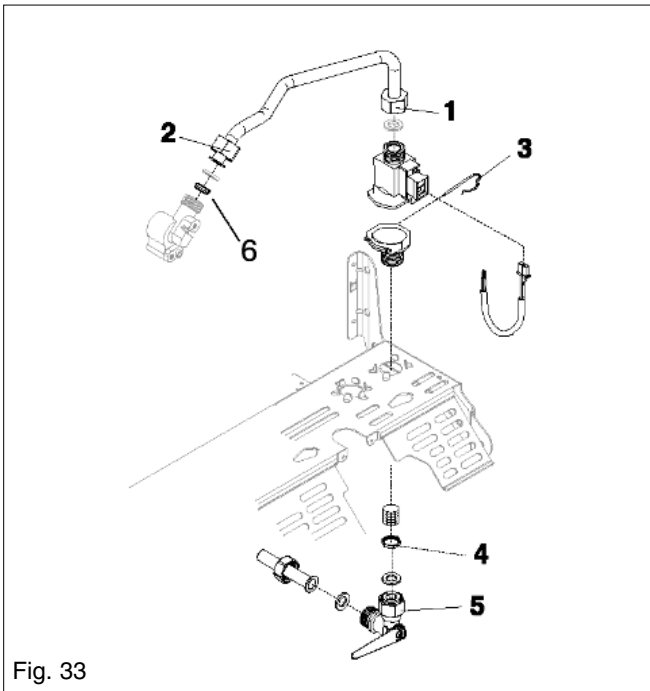

Fig. 33

6.20 DHW FLOW SWITCH fig. 33

Carry out component removal procedure as described in 6.4.

Disconnect and remove the cold water inlet pipe (1,2) from the DHW flow switch & DHW heat exchanger. Disconnect the wiring to the DHW flow switch. Remove the locking pin (3) from the DHW flow switch and lift the DHW flow switch housing from its seating, taking care not to lose the float contained within the housing. Replace in the reverse order ensuring that the housing is firmly inserted onto its seating. Ensure all seals are in good condition, taking care to ensure they are replaced correctly.

6.21 DHW HEAT EXCHANGER

Carry out component removal procedure as described in 6.4.

Locate and remove the screws (1) that secure the heat exchanger to the DHW manifolds. Carefully remove the heat exchanger from its location taking care not to spill any residual water. Replace in the reverse order ensuring that the heat exchanger 'O' ring seals are correctly inserted into the DHW manifolds. Ensure all seals are in good condition, taking care to ensure they are replaced correctly.

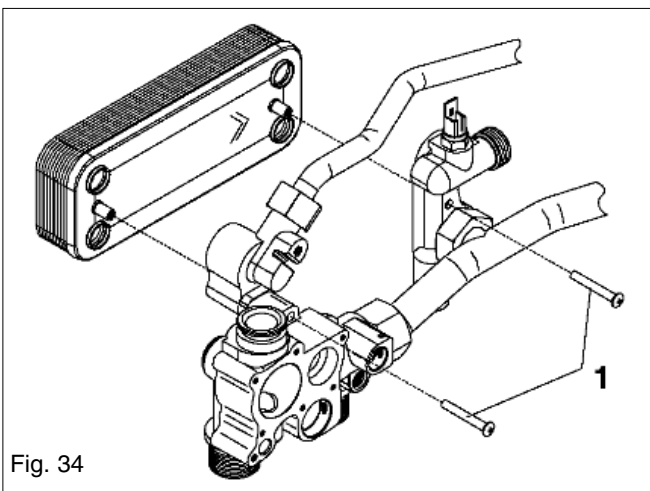

Fig. 34

6.22 VALVE ACTUATOR fig. 35

Carry out component removal procedure as described in 6.4.

Remove the locking pin (1) that secures the actuator to the heating manifold. Disconnect the electrical plug (2) from the actuator. Replace in the reverse order.

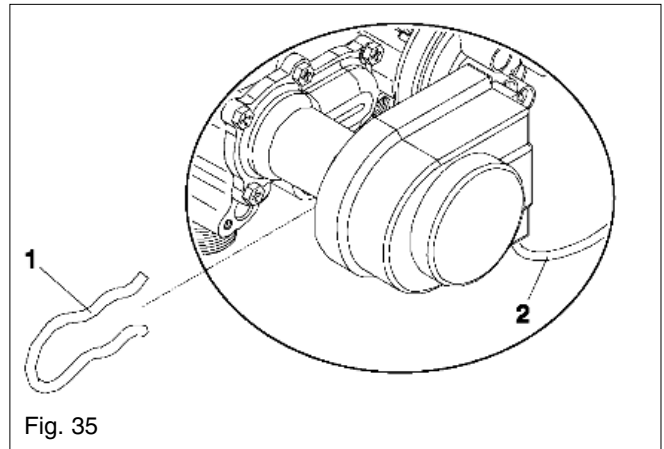

Fig. 35

6.23 DIVERTOR VALVE ASSEMBLY Fig. 36

Carry out component removal procedure as described in 6.4.

Remove the valve actuator as described in 6.22. Locate and remove the 5-screws (2) that secure the valve housing cover to the heating manifold. Gently prise the valve seating assembly and cover (3) from the manifold. Replace in the reverse order ensuring that the seating assembly is inserted properly. Ensure all seals are in good condition, taking care to ensure they are replaced correctly.

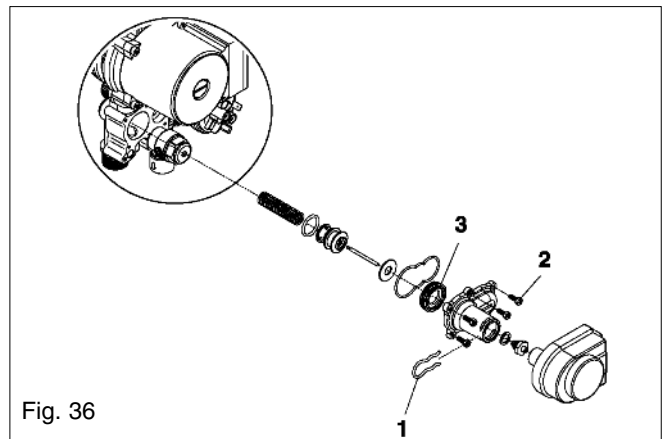

Fig. 36

6.24 SECONDARY THERMISTOR fig. 37

Carry out component removal procedure as described in 6.4. Pull back the protective cover from the thermistor and disconnect the electrical plug. Using a 13mm spanner slacken and remove the thermistor and sealing washer from the DHW heat exchanger manifold. Replace in the reverse order.

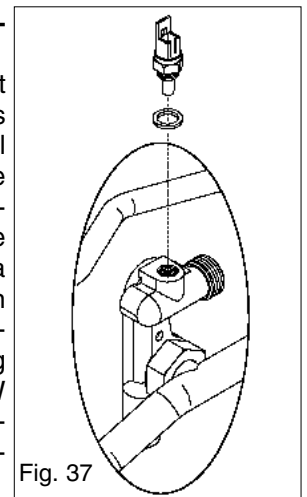
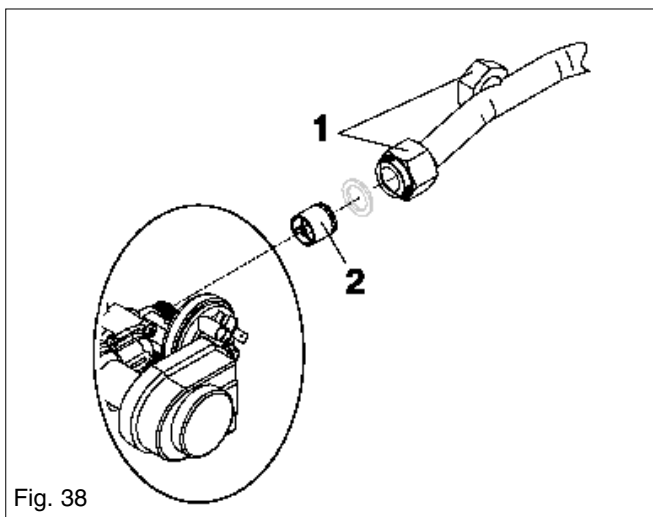

Fig. 37

6.25 AUTOMATIC BYPASS fig. 38

Carry out component removal procedure as described in 6.4.

Disconnect and remove the flow pipe at the heating manifold & DHW manifold (1), and at the connection to the air chamber. Using a hooked piece of wire, carefully withdraw the bypass cartridge (2). Ensure all seals are in good condition, taking care to ensure they are replaced correctly. Replace in the reverse order ensuring the cartridge is facing the correct way.



6.26 DHW NON-RETURN VALVE fig. 39

Carry out component removal procedure as described in 6.4.

Disconnect and remove the flow pipe at the heating and DHW manifold (1), and at the connection to the air chamber. Using a hooked piece of wire, carefully withdraw the non-return cartridge (2). Ensure all seals are in good condition, taking care to ensure they are replaced correctly. Replace in the reverse order ensuring the cartridge is facing the correct way.

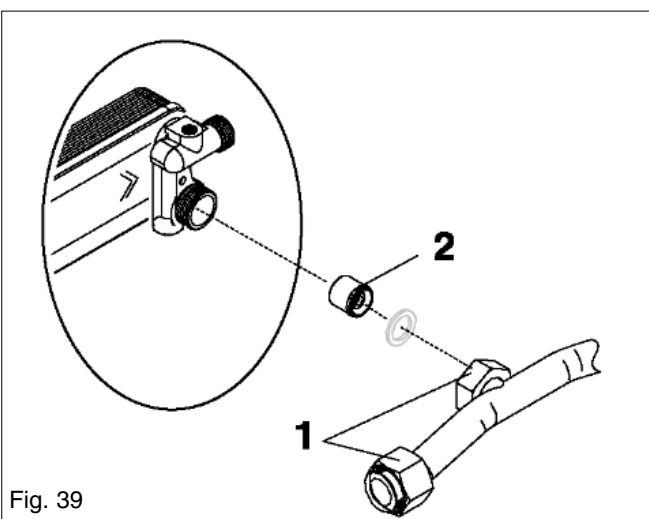

6.27 EXPANSION VESSEL fig. 1

Should the removal and replacement of the expansion vessel be deemed impractical, an external expansion vessel may be fitted to the return pipe as close to the appliance as possible.

6.27.1 EXPANSION VESSEL REMOVAL (with sufficient clearance above)

Carry out component removal procedure as described in 6.4.

Disconnect the flue from the appliance.

Disconnect the flexible expansion pipe from the vessel (Fig. 40). Locate and remove the four screws that secure the vessel top holding plate, remove the plate. The expansion vessel can now be removed. Replace in the reverse order. Ensure all seals are in good condition, taking care to ensure they are replaced correctly.

6.27.2 EXPANSION VESSEL REMOVAL (with insufficient clearance above)

Carry out component removal procedure as described in 6.4.

Disconnect the flue elbow or pipe from the appliance flue outlet. Unclip and remove the air chamber cover, gently pull the cover towards you before lifting and disengaging. Remove the RH side panel of the air chamber. Disconnect the wiring to the fan, pressure switch, primary thermistor, & overheat thermostat. Carefully unclip the wires from the air chamber and withdraw the wiring & grommet from the air chamber. Disconnect the electrode lead and burner thermostat wires. Disconnect the outlet gas pipe and the flow & return pipes from the air chamber.

Locate and remove the 2-screws that secure the lower section of the air chamber. Locate and remove the 2-screws that secure the upper section of the air chamber. The complete air chamber assembly can now be lifted clear from the appliance. Disconnect the flexible expansion pipe from the vessel (fig. 40). Locate and remove the 2-screws that secure the vessel (1). The expansion vessel can now be removed. Replace in the reverse order. Take extreme care when refitting the wiring to the air chamber. Ensure all seals are in good condition, taking care to ensure they are replaced correctly.

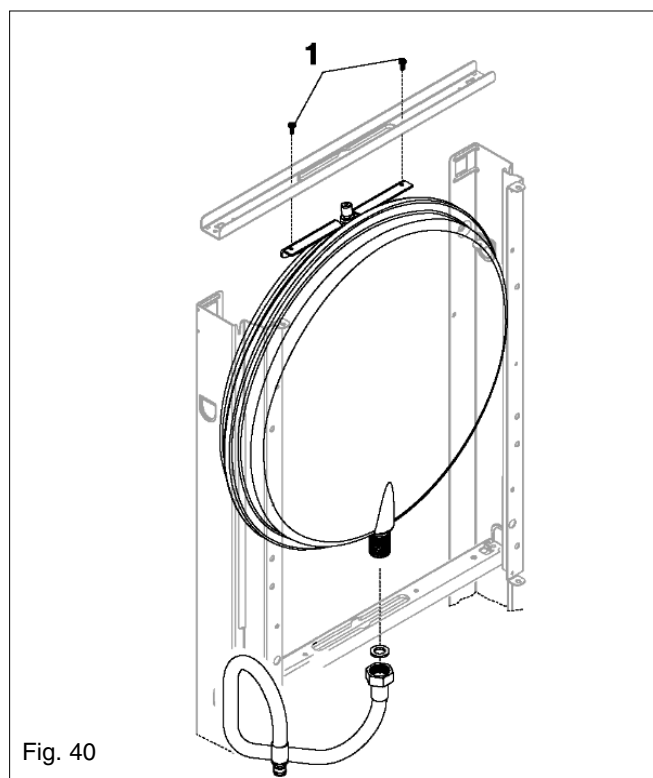

7.1 CHECKING APPLIANCE OPERATION

When carrying out any repairs or servicing to the appliance, the relevant commissioning procedure must be undertaken to ensure the continued safe operation of the appliance. Particular attention should be made to ensure gas soundness, water soundness, and the electrical integrity of the appliance.

7.2 APPLIANCE MODE OF OPERATION

NOTE there must be sufficient system water pressure (min. 0.5 bar) to ensure the water pressure switch is activated. If there is insufficient system pressure the pump and fan will be prevented from operating.

7.2.1 SELECTOR SWITCH IN THE OFF POSITION

When the selector switch is in the OFF position, there is no LED display or LED status indicator. The divertor valve is in the DHW position. The appliance will not respond to any DHW or heating requests.

Active Functions:

- Frost-protection system.
- Pump anti-block.
- Valve actuator anti-block.

7.2.2 SELECTOR SWITCH IN THE HOT WATER ONLY POSITION

When the selector switch is in the HW only position, the status LED is illuminated and the LED display shows the current temperature measured at the secondary (DHW) thermistor. The divertor valve is in the DHW position. The appliance will respond to any DHW requests.

Active Functions:

- DHW pre-heat.
- Frost-protection system.
- Pump anti-block.
- Valve actuator anti-block.

7.2.3 SELECTOR SWITCH IN THE HEATING & HOT WATER POSITION

When the selector switch is in the Heating & HW position, the status LED is illuminated and the LED display shows the current temperature measured at the secondary (DHW) thermistor. The divertor valve is in the DHW position. The appliance will respond to any Heating or DHW requests.

Active Functions:

- DHW pre-heat.
- Frost-protection system.
- Pump anti-block.
- Fan anti-block
- Valve actuator anti-block.

7.2.4 APPLIANCE FUNCTIONS

- **DHW pre-heat**, this function is only active when there are no requests for heating or hot water. When the secondary thermistor drops to 35°C, the pre-heat function is enabled, the appliance operates on minimum power until the secondary thermistor reaches 55°C. Thereafter the pump and fan will over-run for 10-seconds.
- **Frost-protection**, this function is only active when there are no requests for heating or HW. Should the temperature of the primary thermistor drop below 7°C, the valve actuator will motor to the heating position, and the pump will be activated for approximately 20-minutes. Should the temperature of the primary thermistor exceed 10°C during this period, the cycle will be aborted. If the temperature drops below 4°C, the boiler will operate on minimum power until the temperature of the primary thermistor reaches 30°C. Thereafter the pump & fan will over-run for 30-seconds.
- **Anti-block cycle**, when there has been no heating or HW request for 19-hours, the anti-block cycle is activated. The valve actuator will motor from the DHW position to the heating position for a period of 10-seconds and then motor back to the DHW position. Thereafter the pump will be activated for a period of 1-minute. If the selector switch is in the Heating & HW position, the fan will also be active for 1-minute.

7.2.5 HEATING MODE

With the selector switch in the Heating & HW position and any additional controls (time clock, room thermostat, etc.) calling for heat, the appliance will operate in the heating mode. The valve actuator will motor to the heating position and the pump and fan will be active. The operation of the fan causes the analogue pressure switch (PAD) to deliver a signal voltage to the control PCB. If the signal voltage is sufficient a slow ignition sequence is enabled, whereby the current supplied to the gas valve modulating coil is progressively increased from minimum to maximum over a period of 8-seconds. During this period the ignition electrode sparks continuously even if the burner has ignited.

NOTE

If the spark/sensing electrode does not sense ignition the appliance will then go to lockout. Ignition is sensed by the electronic circuitry to ensure flame stability at the burner. Once successful ignition has been achieved, the electronic circuitry allows 75% of the full gas rate through the appliance. After 15 minutes the gas rate is increased to maximum (100%).

When the set-point has been reached (the position of the heating temperature selector) as measured at the primary thermistor, the appliance will begin the modulation phase whereby the fan and gas valve will continuously modulate to maintain the set-point.

If the temperature continues to rise and exceeds the set-point by 6°C, the burner will shut down and the boiler will perform a three-minute anti-cycle (timer delay).

A new ignition sequence will be enabled when the 3-minute anti-cycle has been performed and the temperature at the primary thermistor has dropped 6°C below the set-point.

NOTES

The timer delay can be de-activated by the insertion of a 'jumper' on the PCB or by isolating the appliance from the electrical supply for 30 seconds.

Any DHW request will always have priority over the heating request.

When the request for heating has been satisfied, the appliance pump and fan may continue to circulate to dissipate any residual heat within the appliance.

7.2.6 DHW MODE

With the selector switch in the Heating & HW position, or HW only position, and a DHW outlet is opened, the appliance will operate in the HW mode. The valve actuator will motor to the HW position (if a heating request was active) and the pump and fan will be active. The operation of the fan causes the analogue pressure switch (PAD) to deliver a signal voltage to the control PCB. If the signal voltage is sufficient a slow ignition sequence is enabled, whereby the current supplied to the gas valve modulating coil is progressively increased from minimum to maximum over a period of 8-seconds. During this period the ignition electrode sparks continuously even if the burner has ignited.

NOTE

If the spark/sensing electrode does not sense ignition the appliance will then go to lockout.

Ignition is sensed by the electronic circuitry to ensure flame stability at the burner. Once successful ignition has been achieved, the electronic circuitry modulates the appliance output in order to achieve the DHW set-point (the position of the DHW temperature selector) as measured at the secondary thermistor.

When the set-point has been reached, the appliance will begin the modulation phase whereby the fan and gas valve will continuously modulate to maintain the set-point.

If the temperature continues to rise and exceeds the set-point by 5°C, the burner will shut down until the temperature drops to set-point + 4°C, whereby a new ignition sequence will be enabled. When the request for heating has been satisfied, the appliance fan may continue to operate to dissipate any residual heat from within the appliance.

7.3 CHECKING AND ADJUSTING BURNER PRESSURE (see fig. 19)

Although the burner pressure is factory set, it is necessary to check it during servicing or if the gas valve has been removed.

Isolate the appliance from the electrical supply and attach a suitable manometer to the gas valve outlet test nipple.

7.3.1 SETTING THE MAXIMUM BURNER PRESSURE fig. 41

Light the boiler as described in 5.7 and compare the reading on the manometer with the value described in 2.3. If adjustment is required, remove the protective cap from the gas valve modulating coil assembly and turn the outer (10mm) nut clockwise to increase, or counter-clockwise to decrease the burner pressure.

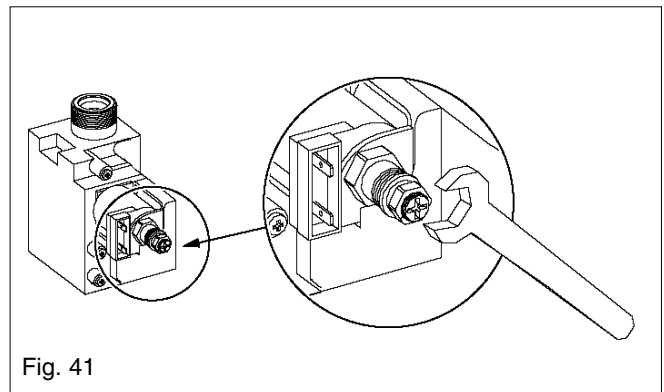

Fig. 41

NOTE

Always check and/or adjust the minimum and maximum gas pressures whilst the appliance is in the HW only mode. Ensure a DHW outlet (preferably the bath) is fully open, and that the HW temperature selector is at maximum

7.3.2 SETTING THE MINIMUM BURNER PRESSURE fig. 42

Once the maximum burner pressure has been checked and/or adjusted, remove one of the grey wires from the modulating coil. Compare the reading on the manometer with the value described in 2.3. If adjustment is required, turn the inner (red) crosshead screw clockwise to increase, or counter-clockwise to decrease the burner pressure, whilst ensuring that the outer (10mm) nut does not move. When checking and/or adjustment has been completed, isolate the appliance from the electrical supply, replace the protective cap, refit the grey wire to the modulating coil, remove the manometer, and tighten the outlet test nipple.

IMPORTANT, A GAS SOUNDNESS CHECK MUST BE CARRIED OUT.

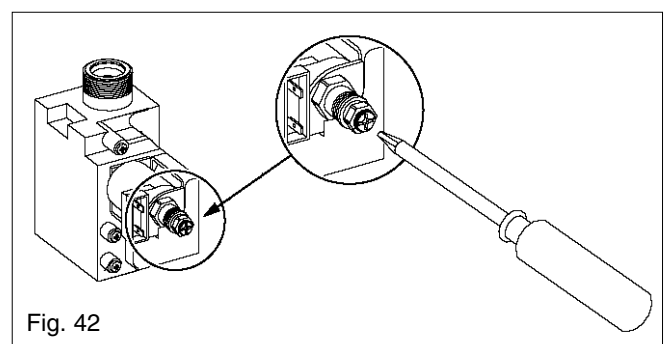

Fig. 42

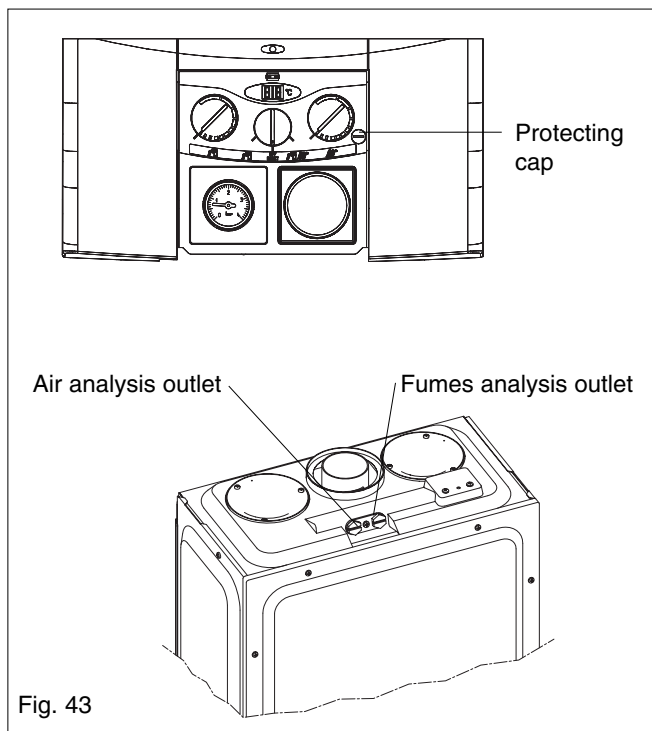

Fig. 43

7.4 COMBUSTION ANALYSIS TEST

A combustion analysis check can easily be carried out on the appliance via the test points located on the top of the appliance, however you must check that the burner pressures are set correctly (see 7.3).

- Insert the flue gas analyser probe into the right hand test point (see fig 43).
- Locate and remove the protective cap that conceals the 'CO mode' button (see fig. 43).
- Light the boiler as described in 5.7 and press the 'CO mode' button once.
- The boiler will now enter the combustion analysis mode (CO mode) for a period of 15 minutes. During this time it will remain on full gas and 'CO' will be displayed on the LED display.
- Once the flue gas analysis has been made, press the 'CO mode' to resume normal operation.

7.5 CHECKING THE EXPANSION VESSEL

Carry out the component removal procedure as described in 6.4. You must ensure that the boiler is completely drained of water.

Using a suitable pressure gauge, remove dust cap on expansion vessel and check the charge pressure. The correct charge pressure should be 1.0 bar \pm 0.1 bar.

If the charge pressure is less, use a suitable pump to increase the charge.

NOTE

You must ensure the safety valve is in the open position whilst re-charging takes place. Replace the dust cap and carry out the relevant commissioning procedure (section 5).

7.6 EXTERNAL FAULTS

Before carrying out any faultfinding or component replacement, ensure the fault is not attributable to any aspect of the installation.

7.6.1 INSTALLATION FAULTS

Symptom	Possible causes
No ignition	Check wiring Check electrical supply
No hot water	Check hot/cold pipe work is not reversed
No central heating	Check wiring of time clock and/or room thermostat

Fault code	Possible causes
01	Gas supply problem Gas line requires purging Reversed polarity Broken, internal flue joint
02	Flow/return valves closed Stuck pump
03	Debris in flue system Debris in flue venturi
04	Insufficient water pressure Air in boiler

7.7 ELECTRICAL CHECKS

Any electrical checks must be carried out by a suitably qualified person.

7.7.1 EARTH CONTINUITY TEST

Isolate the appliance from the electrical supply, and using a suitable multi-meter carry out a resistance test. Connect test leads between an appliance earth point and the earth wire of the appliance supply cable. The resistance should be less than 1 OHM. If the resistance is greater than 1 OHM check all earth wires and connectors for continuity and integrity.

7.7.2 SHORT CIRCUIT CHECK

Isolate the appliance from the electrical supply, and using a suitable multi-meter, carry out a short circuit test between the Live & Neutral connections at the appliance terminal strip (fig.16). Repeat above test on the Live & Earth connections at the appliance terminal strip (fig.16).

NOTE

Should it be found that the fuse has failed but no fault is indicated, a detailed continuity Check will be required to trace the fault. A visual inspection of components may also assist in locating the fault.

7.7.3 POLARITY CHECK

With the appliance connected to the electrical supply and using a suitable multimeter, carry out the following voltage tests:

Connect test leads between the Live & Neutral connections at the appliance terminal strip (fig.16). The meter should read approximately 230V ac. If so proceed to next stage. If not, see 7.7.4.

Connect test leads between the Live & Earth connections at the appliance terminal strip (fig.16). The meter should read approximately 230V ac.

If so proceed to next stage. If not, see 7.7.4. Connect test leads between the Neutral & Earth connections at the appliance terminal strip. (fig.16) the meter should read approximately 0 – 15Vac. If so polarity is correct. If not, see 7.7.4.

7.7.4 REVERSED POLARITY OR SUPPLY FAULT

Repeat the above tests at the appliance isolator, if testing reveals correct polarity and/or supply at the isolator, re-check wiring and connections between the isolator and the appliance.

If tests on the isolator also reveal reversed polarity or a supply fault, consult the local electricity supplier for advice.

7.7.5 RESISTANCE TO EARTH CHECK

Isolate the appliance from the electrical supply, and using a suitable multi-meter carry out a resistance test. Connect test leads between the Live & Earth connections at the appliance terminal strip. (fig.16) If the meter reads other than infinity there is a fault that must be isolated, carry out a detailed continuity check to identify the location of the fault.

IMPORTANT

These series of checks must be carried out before attempting any faultfinding procedures on the appliance. On completion of any task that required the disconnection and re-connection of any electrical wiring or component, these checks must be repeated.

7.8 FAULT FINDING

Before attempting any faultfinding, the electrical checks as detailed in 7.7 must be carried out.

Isolate the appliance from the electrical supply. Disconnect any external controls from terminals TA & Spare of the appliance terminal strip, and make safe. Insert a solid link-wire between terminals TA & TA.

Ensure jumper tags are fitted to the main PCB at:

- JP6
- JP7
- JP8 (Nat. Gas only).
- M7

NOTE

If the Vokera remote-control (RC05) is connected to the appliance, it should be disconnected during any faultfinding checks.

Restore the electrical supply to the boiler and turn the selector switch to the on position. The boiler should now function as described in section 7.2. Should the boiler fail to respond, the internal fuses and connectors should be checked to ensure integrity and continuity. If the boiler still fails to respond, refer to the detailed faultfinding flowcharts overleaf.

7.9 FAULT CODES

When the boiler displays a fault code, the appropriate code is shown on the display, accompanied by a flashing red LED. To reset the boiler, slowly turn the mode selector switch to the reset position then back to the on position.

If the boiler does not reset, refer to the following section and the detailed faultfinding flowcharts overleaf.

FAULT CODE 01

Fault code 01 appears when the burner has failed to ignite, or the flame supervision system has failed to detect a flame.

- Check incoming gas supply
- Check spark electrode
- Check polarity
- Check integrity of flue system
- Check gas valve
- Check ignition control PCB

FAULT CODE 02

Fault code 02 appears if the boiler has overheated.

- Check high limit thermostat
- Check thermistors
- Check pump
- Check gas pressures

FAULT CODE 03

Fault code 03 appears if the boiler or flue system has developed a fault.

- Check operation of fan
- Check flue venturi
- Check analogue pressure switch
- Check flue system

FAULT CODE 04

Fault code 04 appears if the pressure in the boiler is low.

- Check water pressure
- Check water pressure switch
- Check water pressure gauge

FAULT CODE 05

Fault code 05 appears if the appliance is connected to the optional remote control (RC05) and there is a communication problem.

- Check wiring between RC05 and appliance

FAULT CODE 06

Fault code 06 appears if a problem exists with the secondary (DHW) thermistor.

- Check thermistor
- Check wiring continuity

FAULT CODE 07

Fault code 07 appears if a problem exists with the primary thermistor.

- Check thermistor
- Check wiring continuity

FAULT CODE 08

Fault code 08 appears if the burner thermostat has been activated.

- Check gas pressures
- Check burner thermostat
- Check wiring continuity

FAULT CODE 09

PCB fault

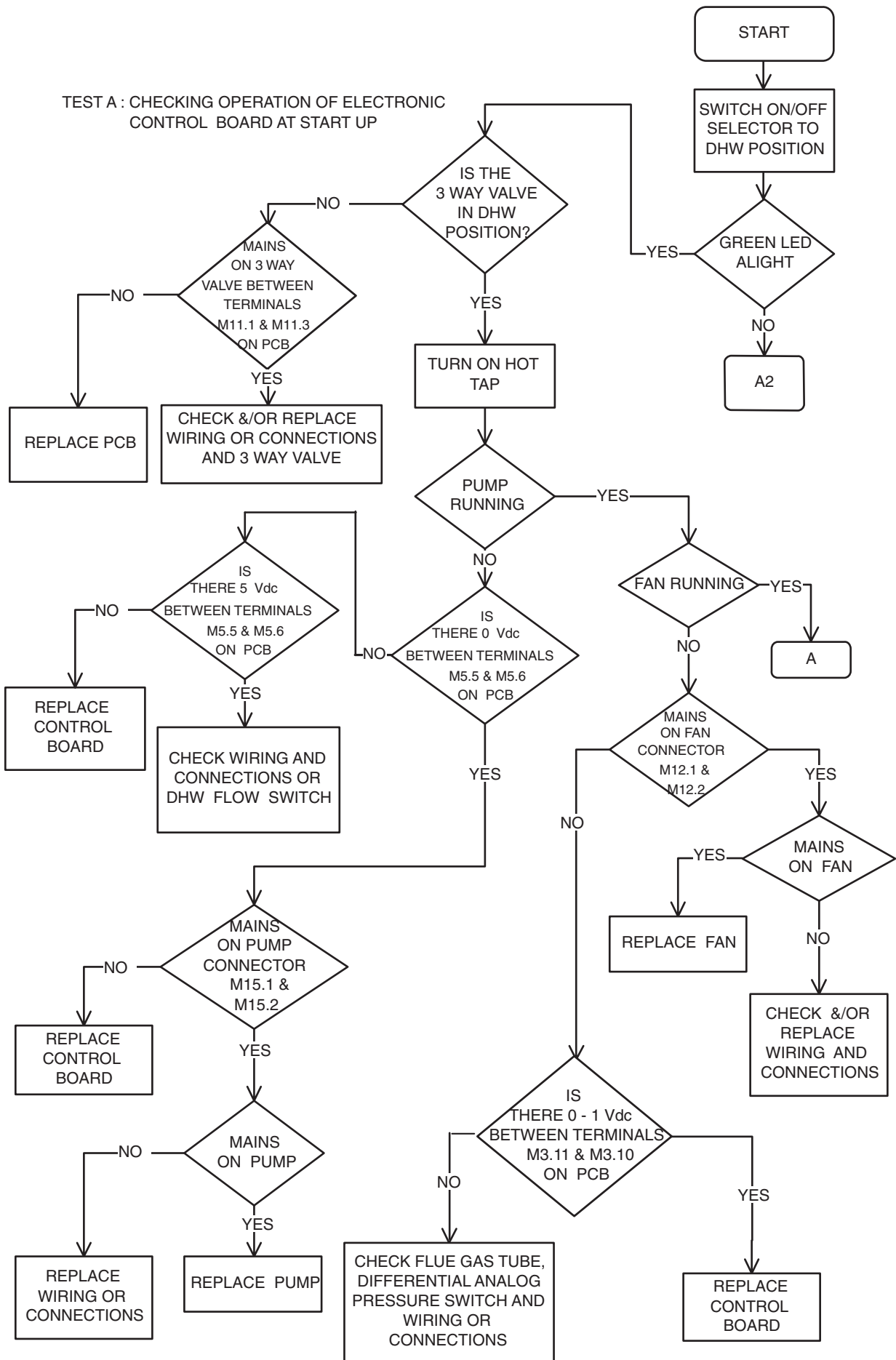

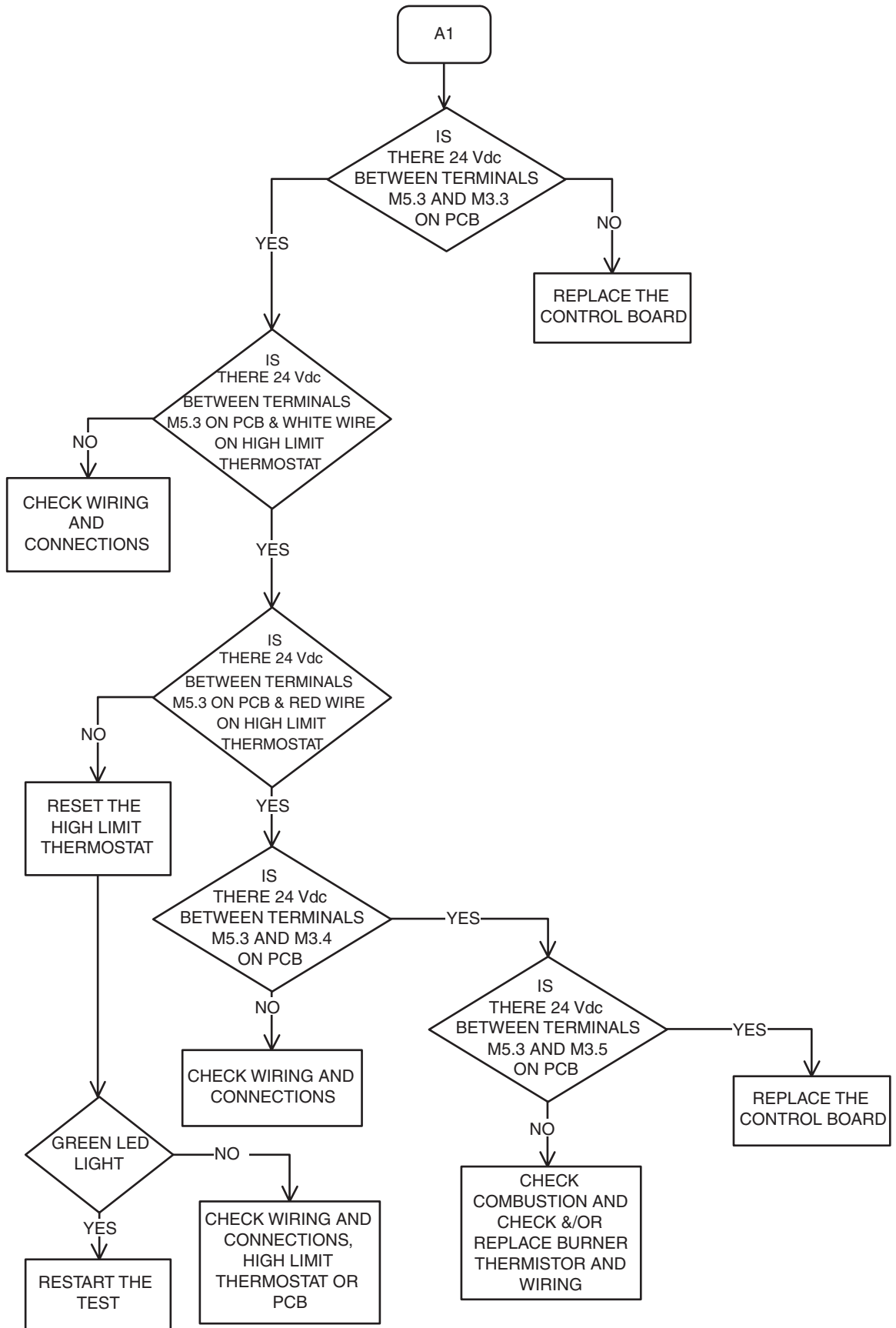

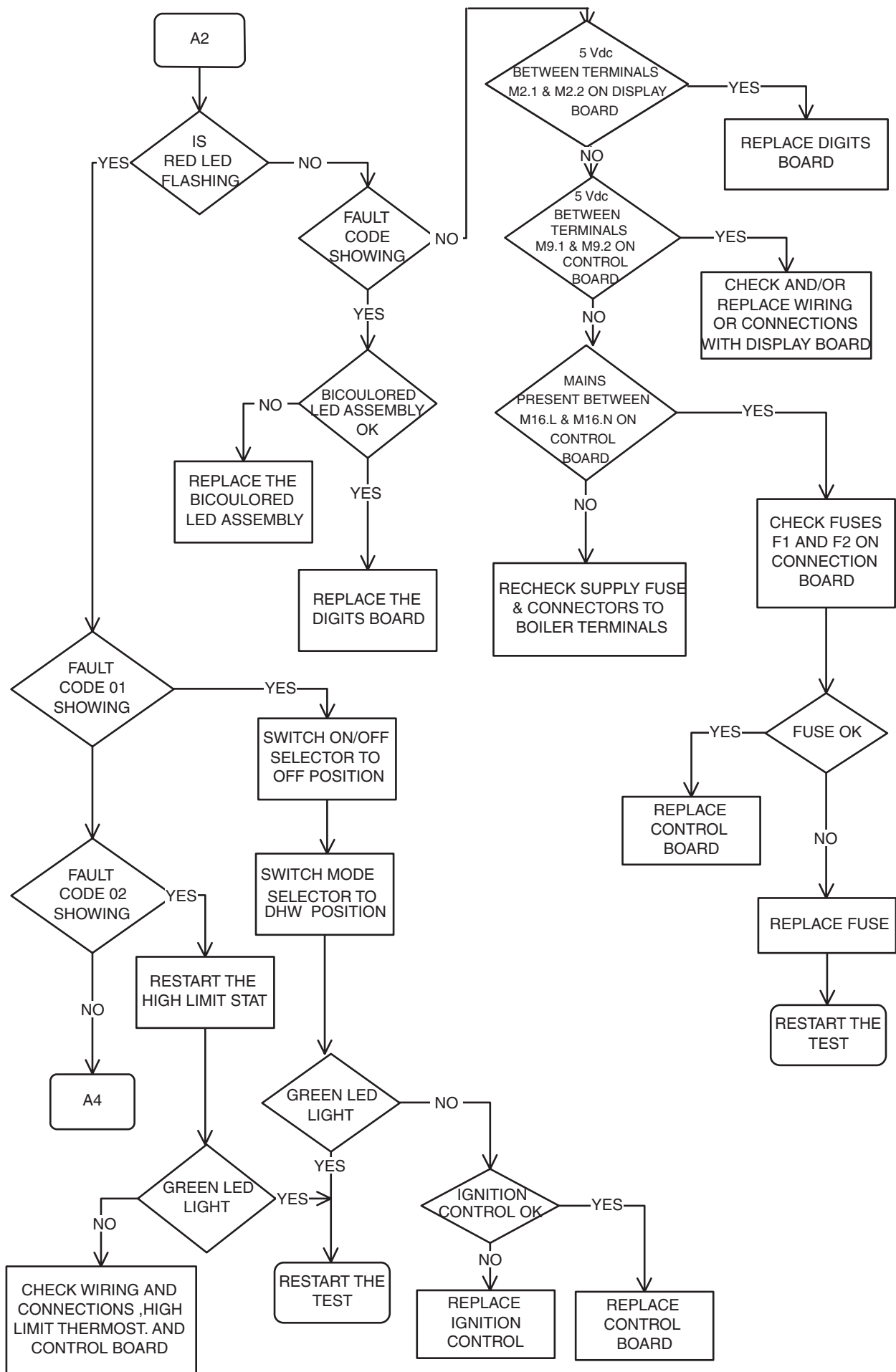

TEST B : CHECK CONTROL
IN DHW MODE

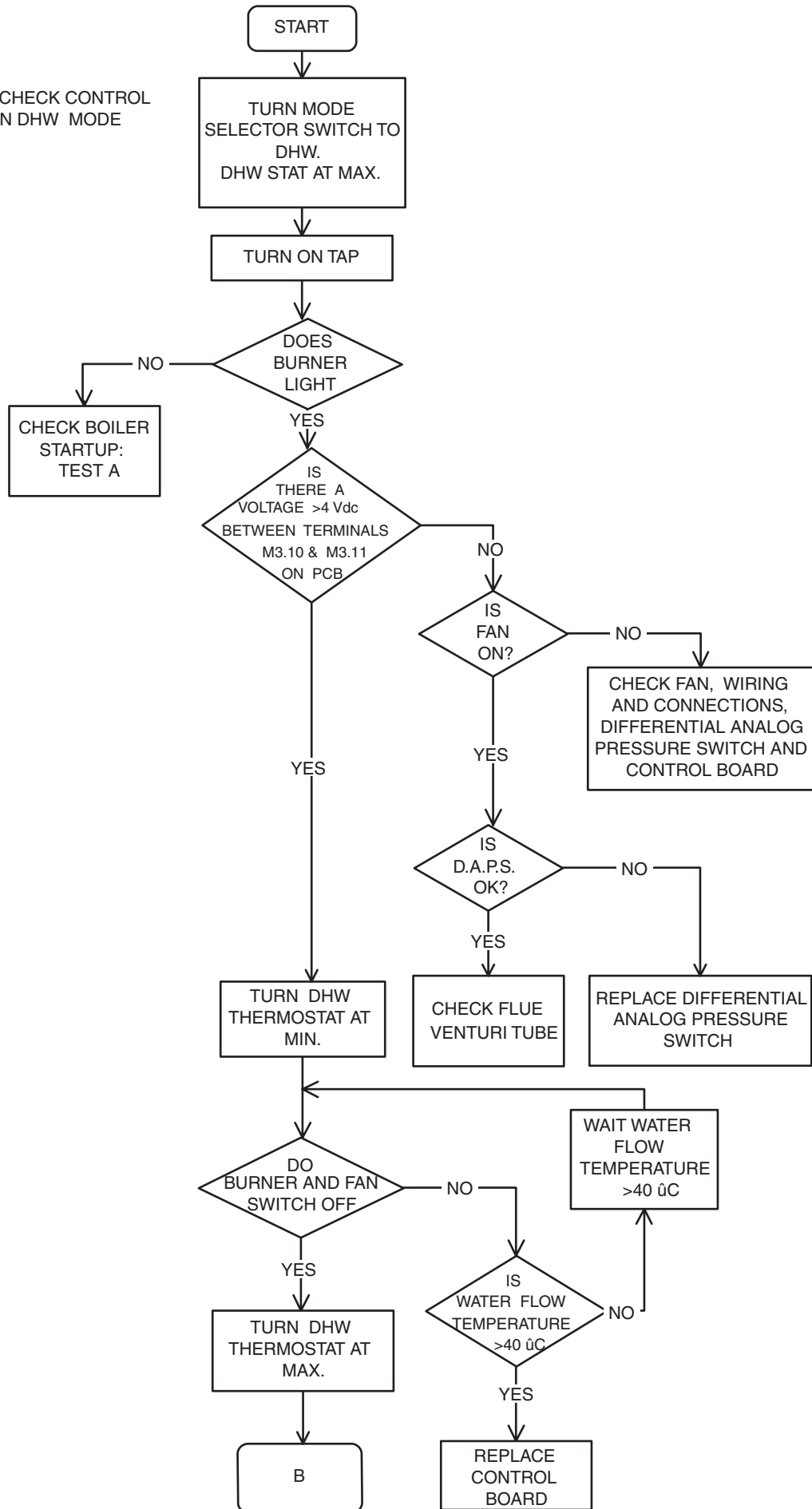

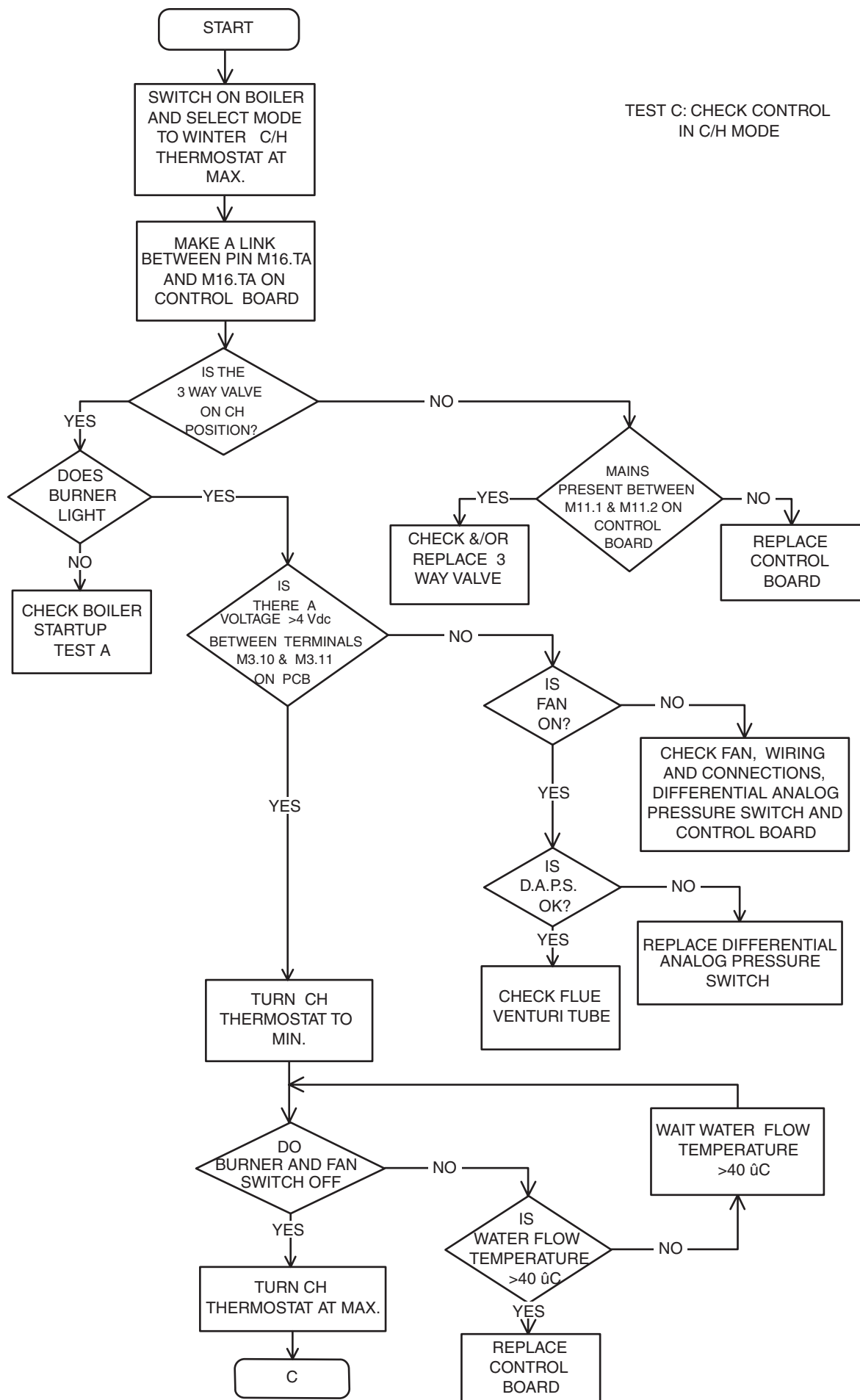

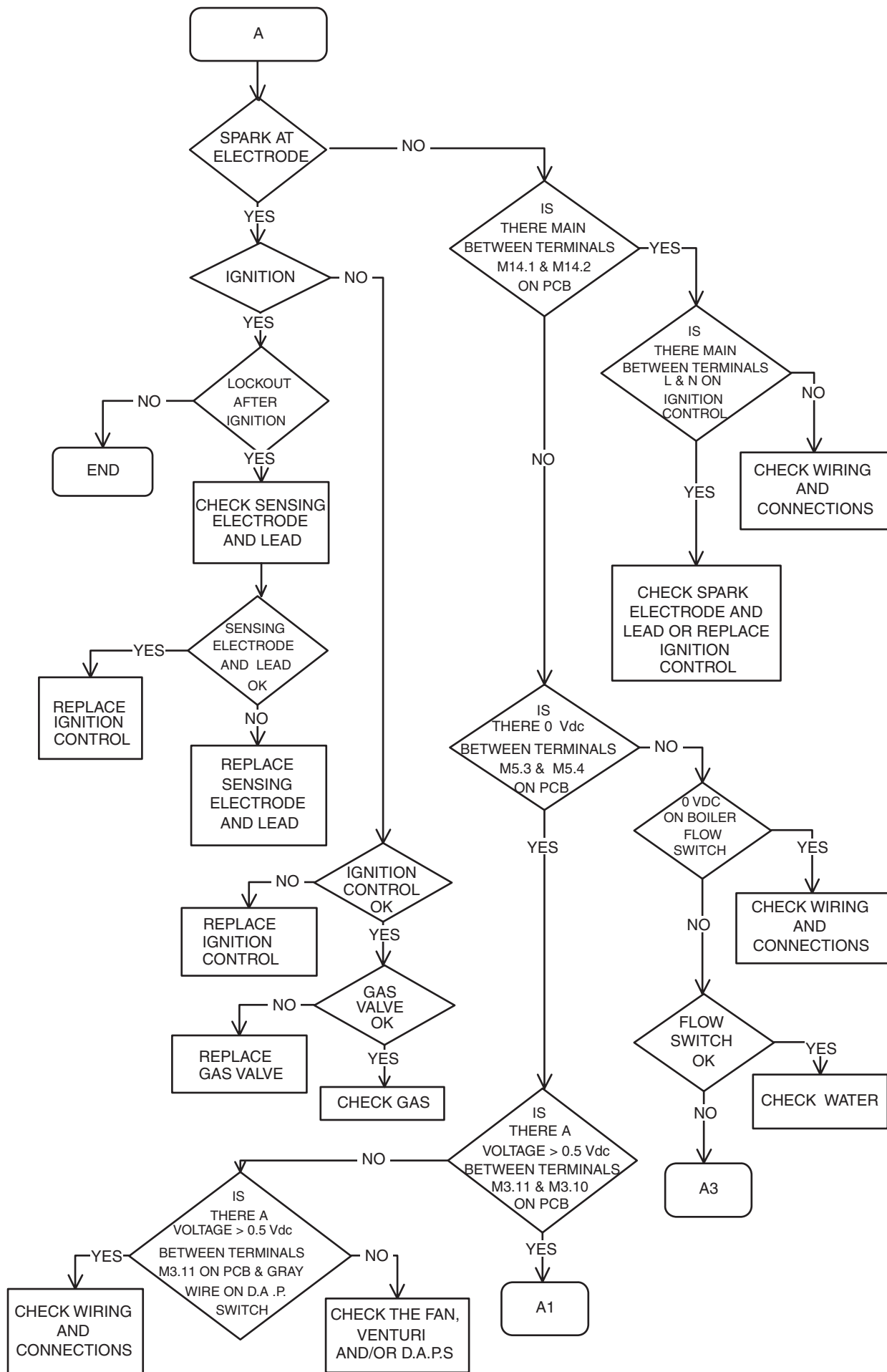

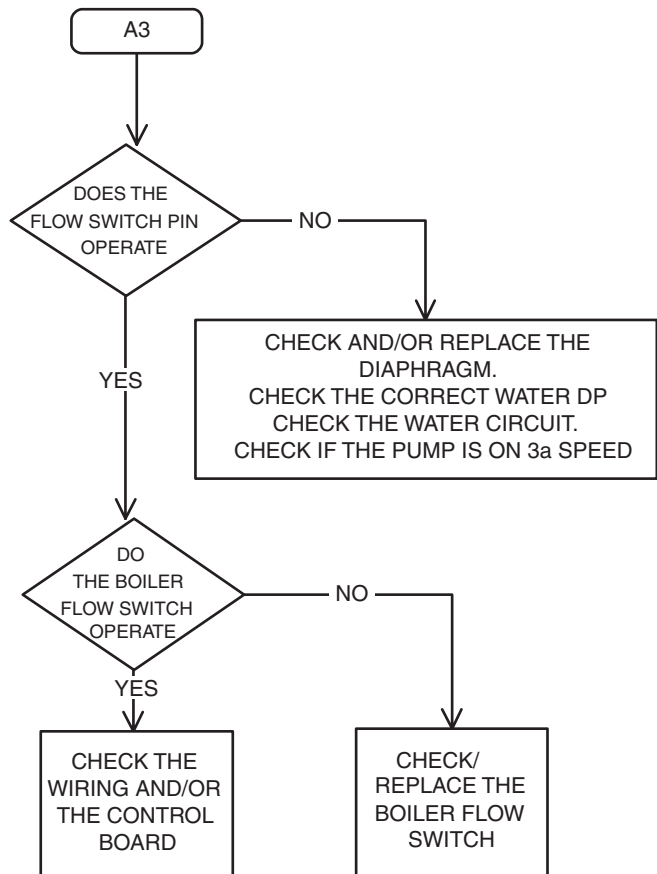
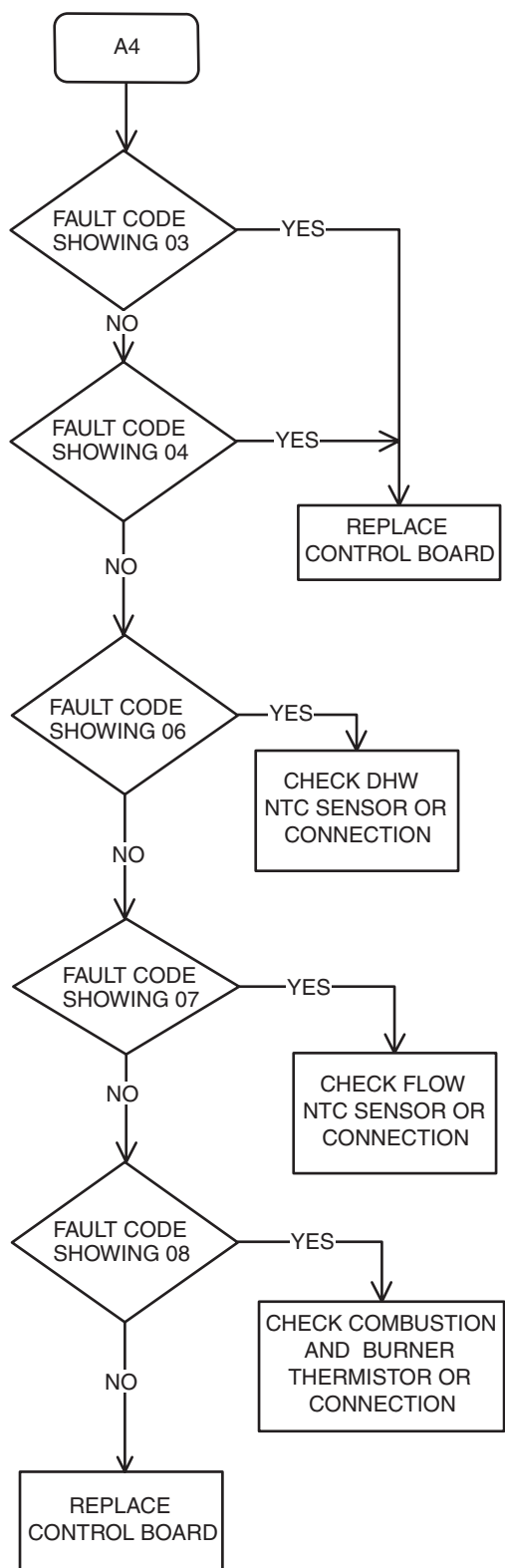

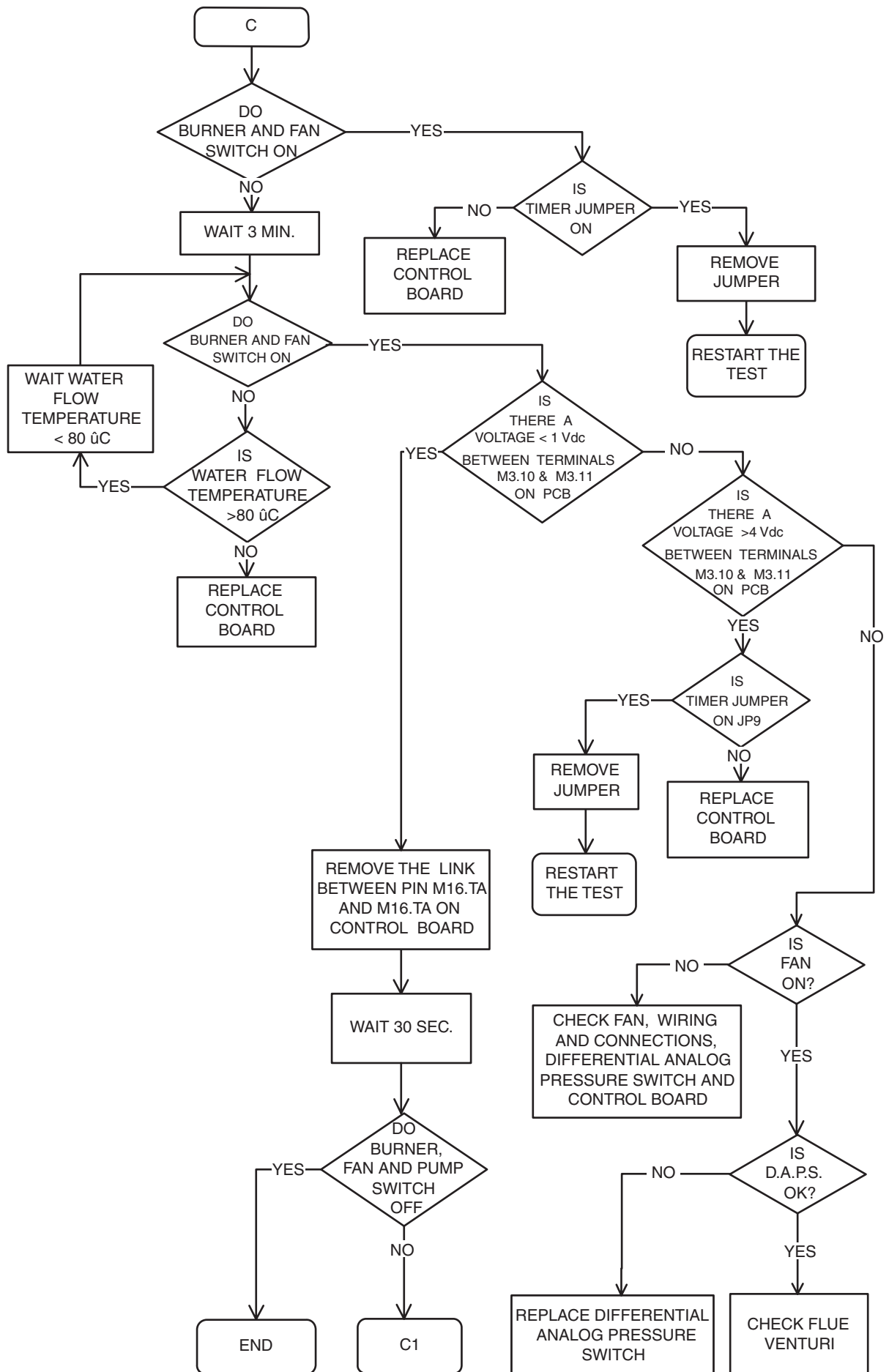
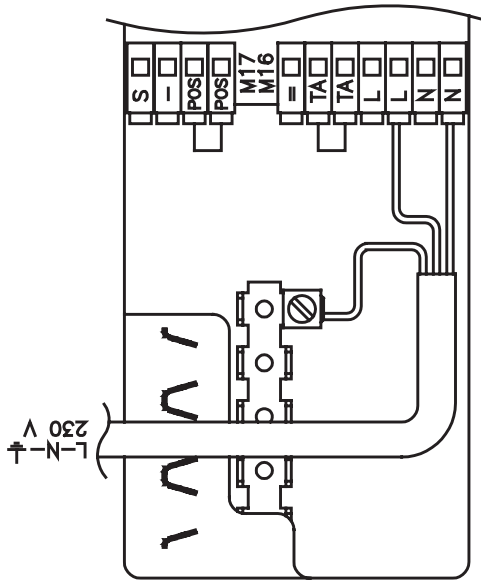
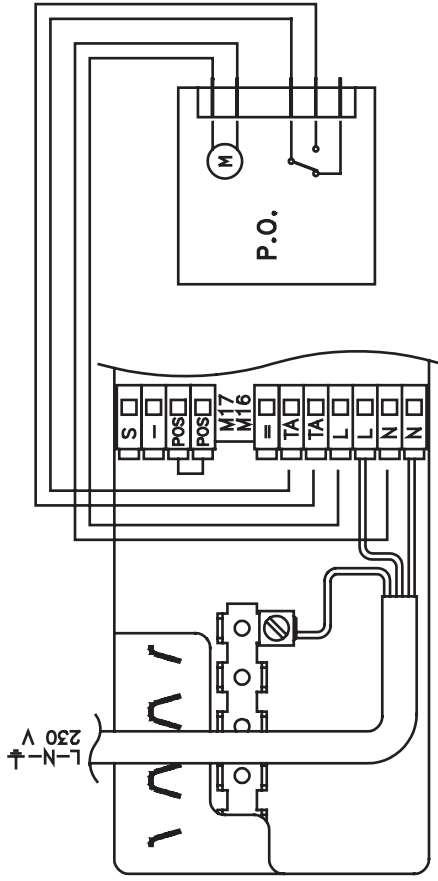

Fig. 46



Basic wiring with link between TA & TA (no controls fitted)



Appliance wired to basic voltage-free time clock

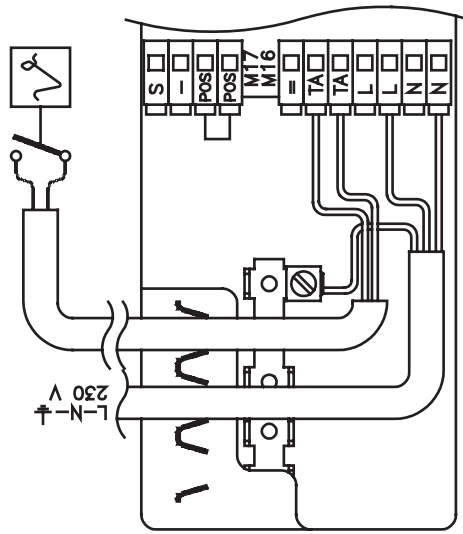

Appliance wired to programmable room thermostat

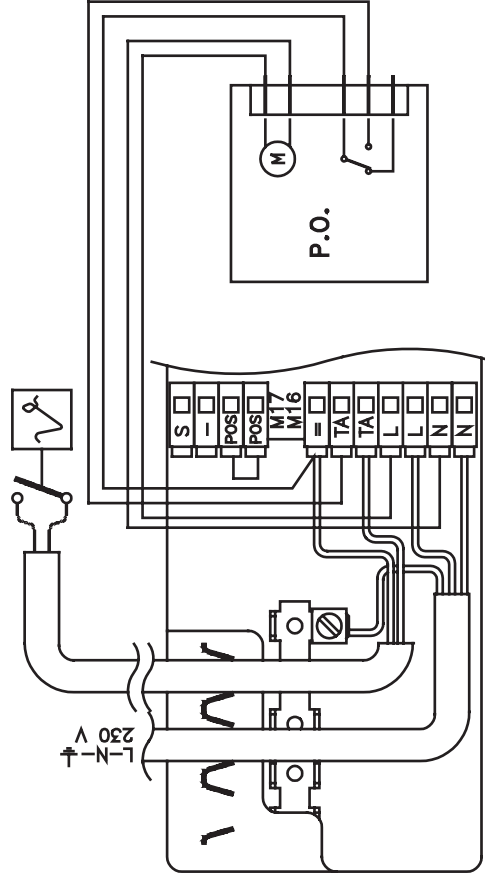

Appliance wired to basic voltage-free time clock and room thermostat

FUNCTIONAL DIAGRAM

NOTE: L-N-E CONNECTION IS ADVISABLE

CONTROL SWITCHING OF TIME CLOCK AND ROOM THERMOSTAT IS 230 V.a.c.

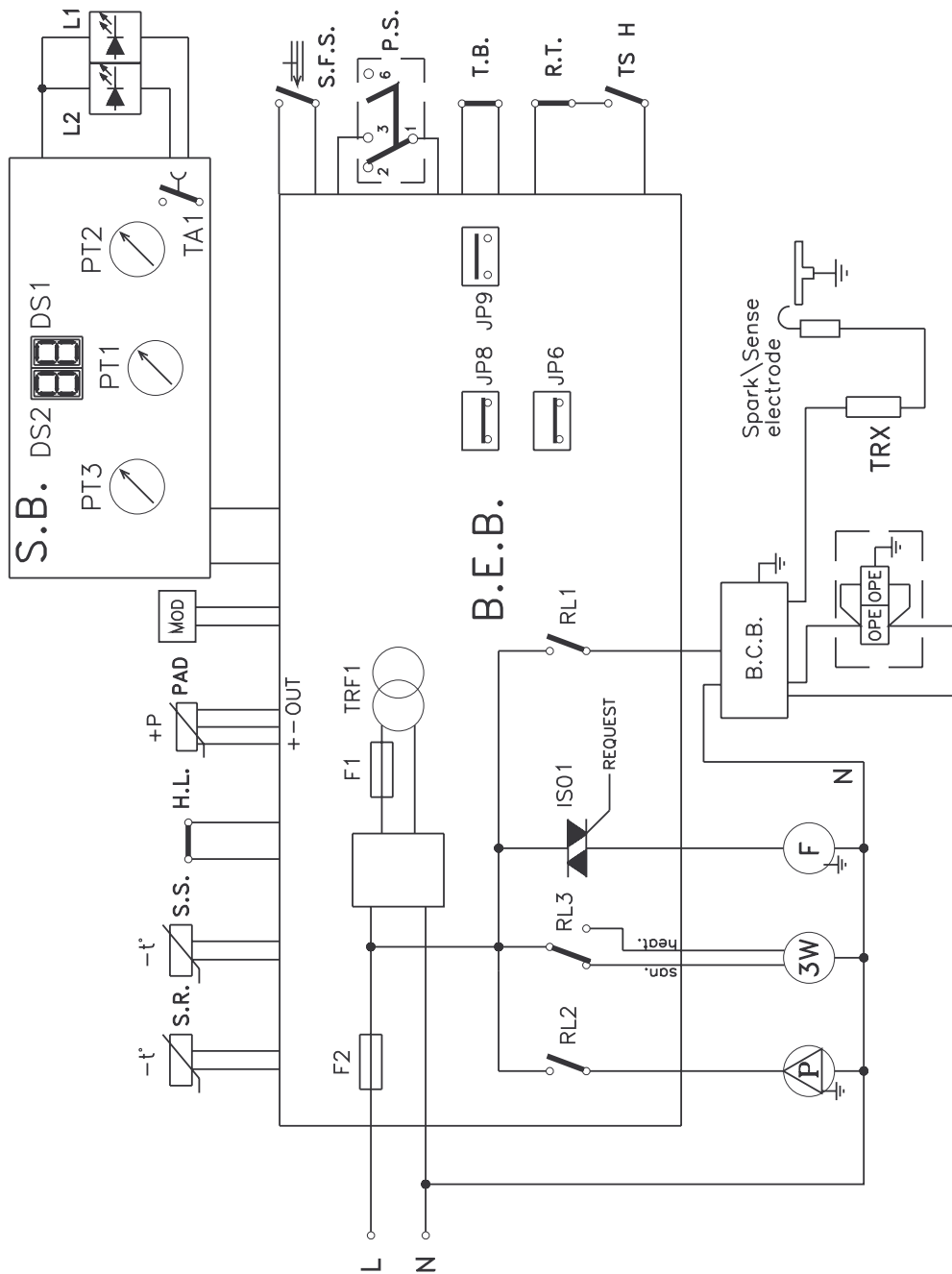

- | | | | |
|-----------------|--------------------------------|-------------------|--|
| R.T. | Room thermostat | JP9 | Timer on- off selector |
| TS H | Heat time switch | JP7 | Room thermostat or remote control jumper |
| S.F.S. | Domestic hot water flow switch | PT2 | Central heating temperature control |
| P.S. | Pressure switch | PT3 | Domestic hot water temperature control |
| H.L. | High limit thermostat | PT1 (S.B.) | Selection of 0-reset / winter - summer |
| S.R. | Heat thermistor | DS1÷DS2 | Temperature / alarm display |
| S.S. | Domestic hot water thermistor | TA1 | Combustion test |
| MOD | Modulator | F1 | Fuse 100 mA F (on 24V circuit) |
| F | Fan | F2 | Fuse 2 A F (on 230 V circuit) |
| P | Pump | RL1 | Ignition relay |
| 3W | 3 way motor | RL2 | Pump relay |
| SP\SE E. | Spark\Sense electrode | RL3 | 3 way relay |
| OPE | Gas valve solenoids | IS01 | Fan triac |
| B.C.B. | Burner control board | L1 | Led OK (green) |
| B.E.B. | Boiler control board | L2 | Led alarm (blink red) |
| S.B. | Secondary board | TRF1 | Transformer |
| JP6 | Pre-heating jumper | PAD | Differential analogue pressure switch |
| JP8 | Natural gas or L.P.G. selector | T.B. | Burner thermostat |

WIRING DIAGRAM

NOTE: L-N-E CONNECTION IS ADVISABLE
 CONTROL SWITCHING OF TIME CLOCK AND ROOM THERMOSTAT IS 230 V.a.c.

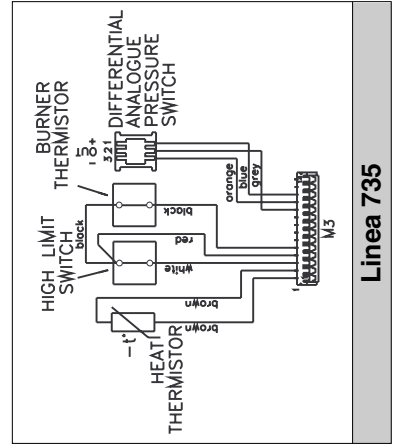
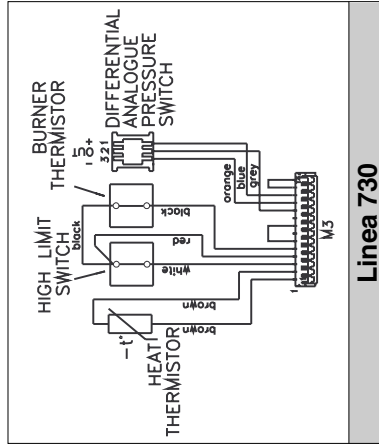
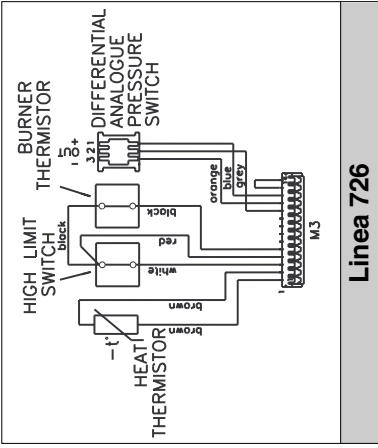
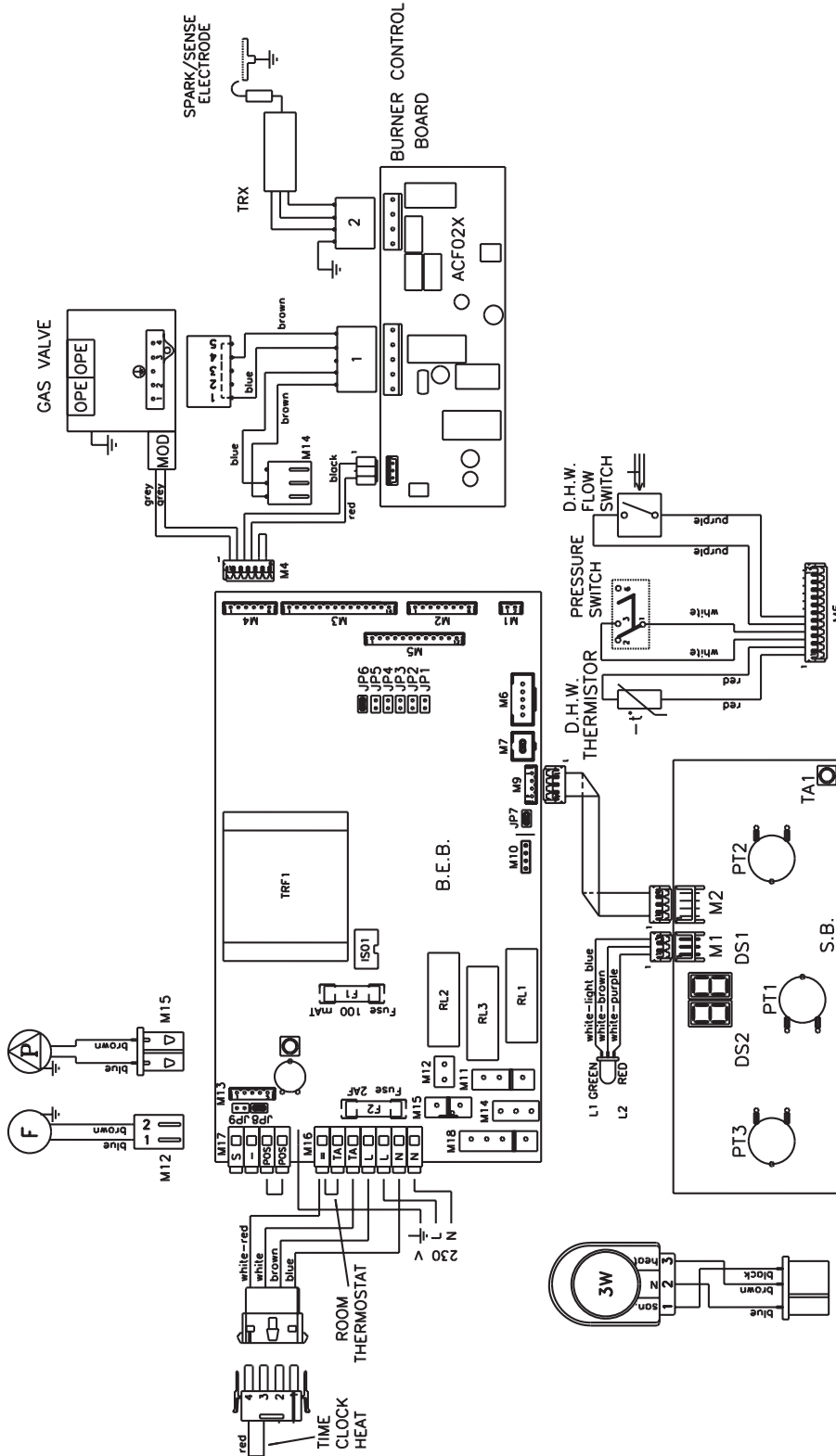

SECTION 9 EXPLODED DIAGRAMS

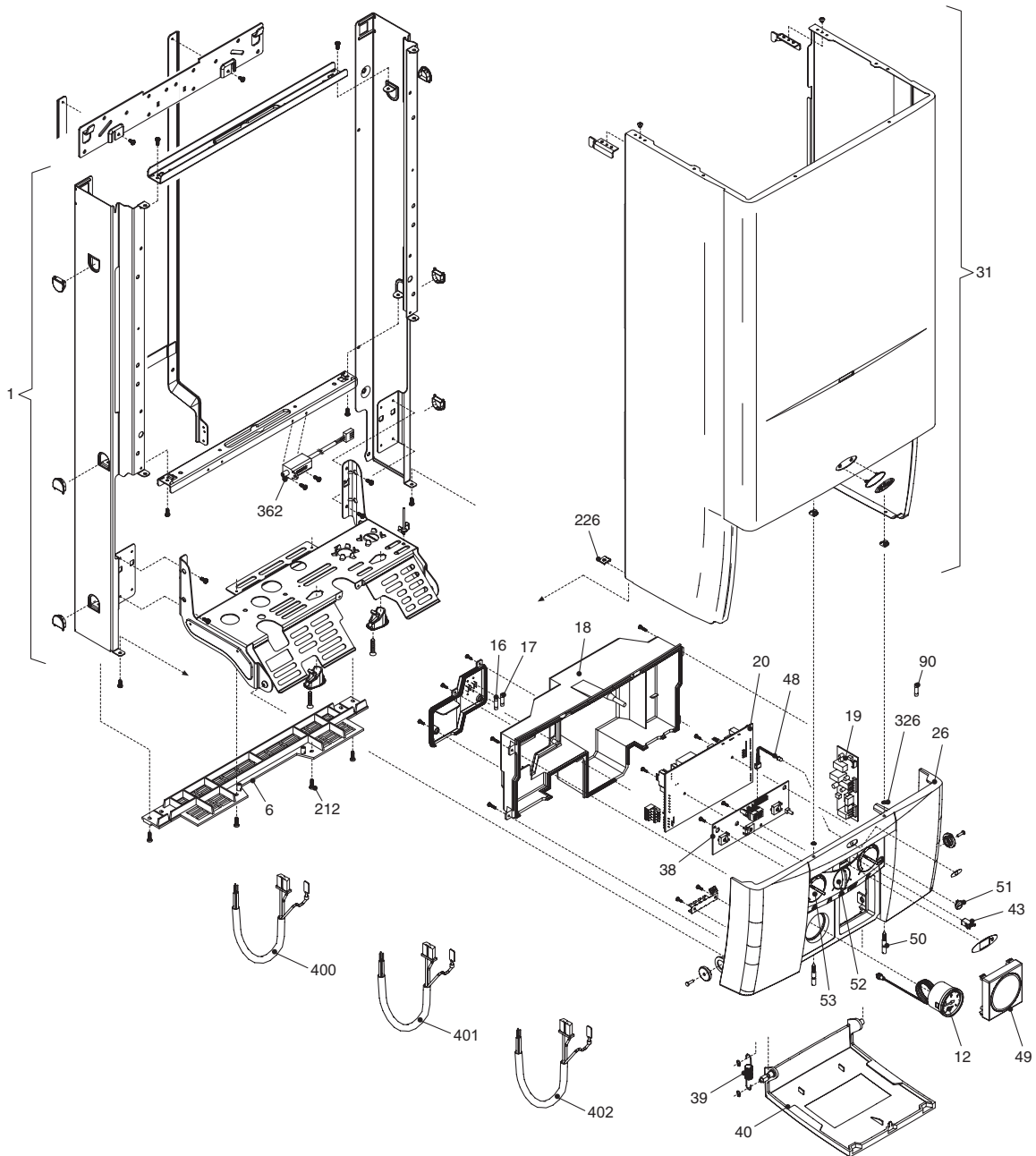

POS.	DESCRIPTION	726	730	735
1	Frame	R01005133	R01005134	R01005212
6	Guard	R1913	R1913	R1913
12	Quick primer pressure gauge	R1857	R1857	R1857
16	2A fuse	R8968	R8968	R8968
17	100 mA fuse	R1947	R1947	R1947
18	Cover	R10021849	R10021849	R10021849
19	Ignition module	R10021848	R10021848	R10021848
20	Printed Circuit Board	R10024731	R10024731	R10024731
26	Instrumental panel	R10021951	R10022015	R10022029
31	Case	R1880	R1922	R2062
38	Printed Circuit Board	R10024558	R10024558	R10024558
39	Spring	R1862	R1862	R1862
40	Door panel	R10024465	R10024465	R1996
43	Push-push cover	R1864	R1864	R1864
48	Led Light Guide	R1858	R1858	R1858
49	Hole cap	R8654	R8654	R8654
50	Pin	R1867	R1867	R1867
51	Hole cover	R1861	R1861	R1861
52	Selector knob kit	R01005072	R01005072	R01005072
53	Control knob kit	R01005073	R01005073	R01005073
90	3A fuse	R3478	R3478	R3478
212	Screw	R5080	R5080	R5080
226	Edge clip	R5128	R5128	R5128
326	O ring	R1869	R1869	R1869
362	Transformer	R10022659	R10022659	R10022659
400	Wiring harness	R10021117	R10021117	R10021117
401	Wiring harness	R1780	R1780	R1780
402	Wiring harness	R1980	R1980	R1980

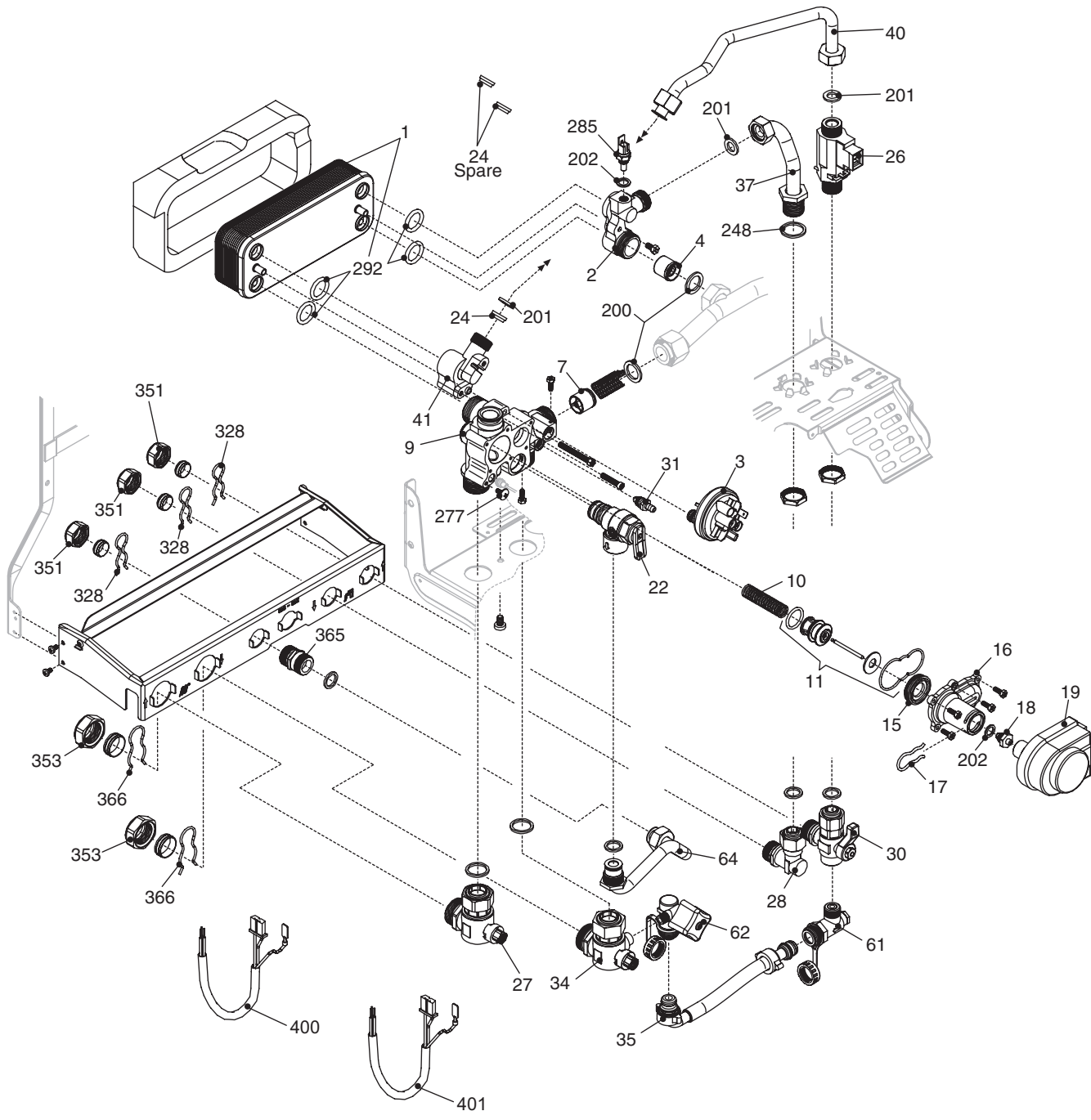

POS.	DESCRIPTION	726	730	735
1	Domestic water heat exchanger	R8037	R1957	R10024627
2	Connection	R9807	R9807	R9807
3	Pressure switch	R2044	R2044	R2044
4	Non return valve	R2908	R2908	R2908
7	By-pass valve	R2047	R2047	R1552
9	Heating manifold	R10020439	R10020439	R10020439
10	Spring	R6862	R6862	R6862
11	Three way valve overhaul kit	R01005127	R01005127	R01005127
15	Seating plate	R7134	R7134	R7134
16	Three way valve cover	R2904	R2904	R2904
17	Fixing fork wrench	R2906	R2906	R2906
18	O ring connection	R6919	R6919	R6919
19	Motorized valve	R2905	R2905	R2905
22	Safety valve	R1806	R1806	R1806
24	Flow governor	R10024462	R8009	R9430
24	Flow governor (spare)	R8008	R10020041	R10020041
24	Flow governor (spare)	R8009	R10024462	R1321
26	DHW actuator	R10022349	R10022349	R10022349
27	Heating cock	R1789	R1789	R1789
28	Connection	R1790	R1790	R1790
30	Heating cock	R10023567	R10023567	R10023567
31	Venting plugs kit	R01005137	R01005137	R01005137
34	Heating cock	R10023566	R10023566	R10023566
35	Flexible pipe	R10023570	R10023570	R10023570
37	Pipe	R1631	R1631	R10023211
40	Pipe	R10022125	R10022125	R10023210
41	Connection	R2903	R2903	R2903
61	Non return valve	R10023569	R10023569	R10023569
62	Filling cock	R10023568	R10023568	R10023568
64	Pipe	R10023643	R10023643	R10023643
200	Washer	R5023	R5023	R5023
201	Washer	R5026	R5026	R5026
202	Washer	R5041	R5041	R5041
248	Washer	R5208	R5208	R5208
277	Screw	R6903	R6903	R6903
285	NTC sensor	R8484	R8484	R8484
292	O ring	R7999	R7999	R7999
328	Clip	R1890	R1890	R1890
351	Nut	R1823	R1823	R1823
353	Nut	R1824	R1824	R1824
365	Nipple	R1793	R1793	R1793
366	Clip	R1820	R1820	R1820
400	Wiring harness	R10020530	R10020530	R10020530
401	Wiring harness	R1873	R1873	R1873

* R1321 Green flow governor
* R8008 Withe flow governor
* R8009 Blu flow governor
* R9430 Red flow governor
* R10020041 Beige flow governor
* R10024462 Orange flow governor

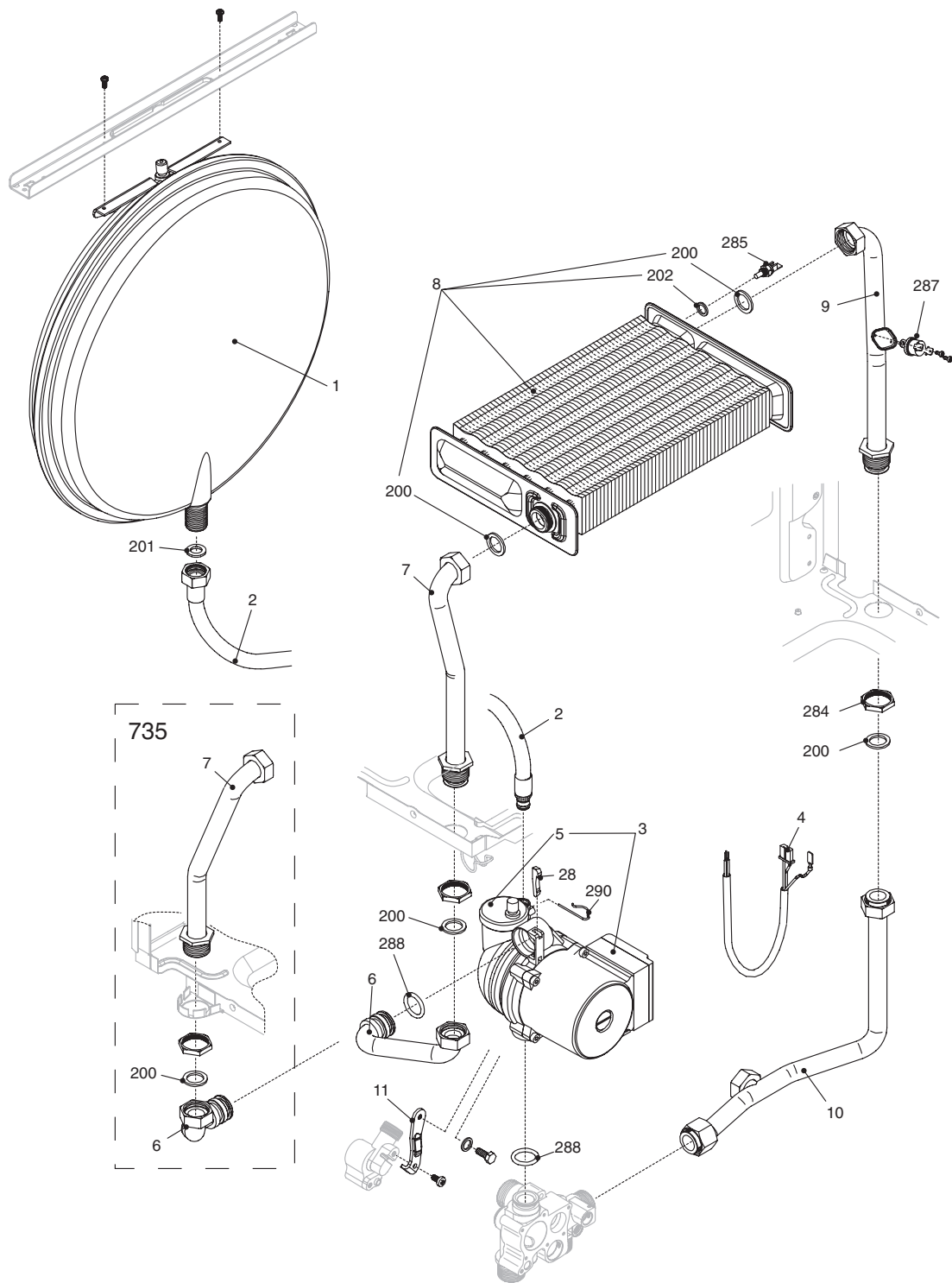

POS.	DESCRIPTION	726	730	735
1	Expansion vessel	R2204	R2204	R2573
2	Flexible pipe	R2164	R2164	R2164
3	Pump	R10020437	R10020437	R10020438
4	Wiring harness	R1845	R1845	R1845
5	Automatic air vent bottle	R0439	R0439	R0439
6	Pipe	R10023195	R10023202	R10023209
7	Pipe	R1847	R1847	R2051
8	Heat exchanger	R10024578	R10023579	R10024580
9	Pipe	R10021041	R10021041	R10020519
10	Pipe	R10023198	R10023203	R10023208
11	Bracket	R2940	R2940	R2940
28	Pump lock key	R9263	R9263	R9263
200	Washer	R5023	R5023	R5023
201	Washer	R5026	R5026	R5026
202	Washer	R5041	R5041	R5041
285	NTC sensor	R8484	R8484	R8484
287	Limit thermostat	R2258	R2258	R2258
288	O-ring	R6898	R6898	R6898
290	Clip	R2165	R2165	R2165

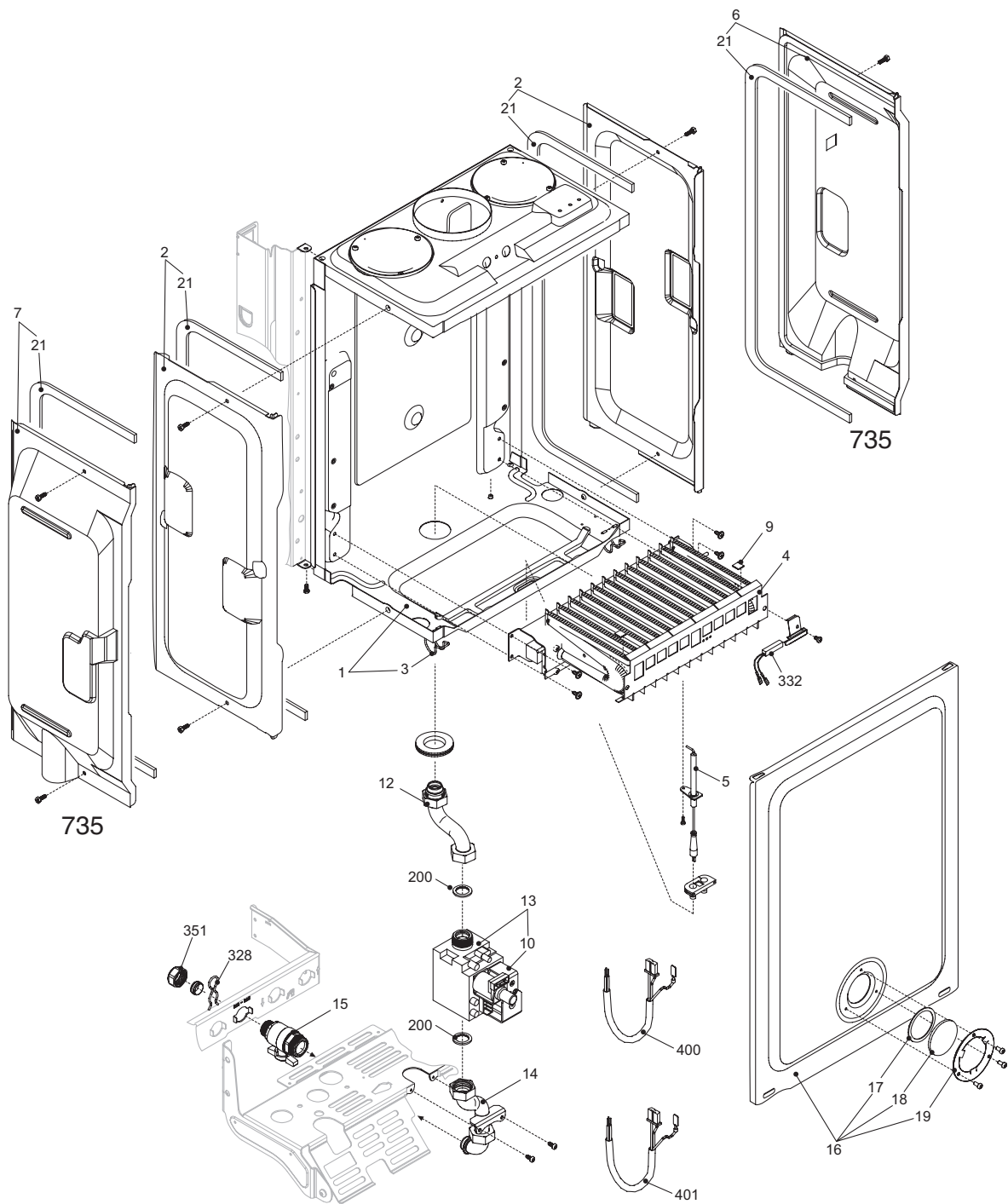

POS.	DESCRIPTION	726	730	735
1	Air box bottom	R10023095	R10022388	R10024792
2	Ambidx air box side	R1549	R1549	-
3	Air box clip	R0442	R0442	R0442
4	NG Burner	R10024463	R10024524	R10024752
4	LPG burner	R10024464	R10024525	R10024753
5	Spark electrode	R10022027	R10022027	R10022027
6	Air box side	-	-	R2059
7	Air box side	-	-	R2060
9	NG plate	R5172	R5172	-
10	Gas valve solenoid	R10020838	R10020838	R10020838
12	Gas pipe	R1839	R1839	R1839
13	Gas valve	R10021021	R10021021	R10021021
14	Gas pipe	R1840	R1840	R1840
15	Gas cock	R1787	R1787	R1787
16	Air box cover	R10020216	R10020217	R10020430
17	Wascher	R5072	R5072	R5072
18	Glass	R3139	R3139	R3139
19	Glass flange	R4007	R4007	R4007
21	Washer	R5905	R5905	R5905
200	Washer	R5023	R5023	R5023
328	Clip	R1890	R1890	R1890
332	Thermostat	R2600	R2600	R2600
351	Nut	R1823	R1823	R1823
400	Wiring harness	R10021947	R10021947	R10021947
401	Wiring harness	R10024466	R10024466	R10024466

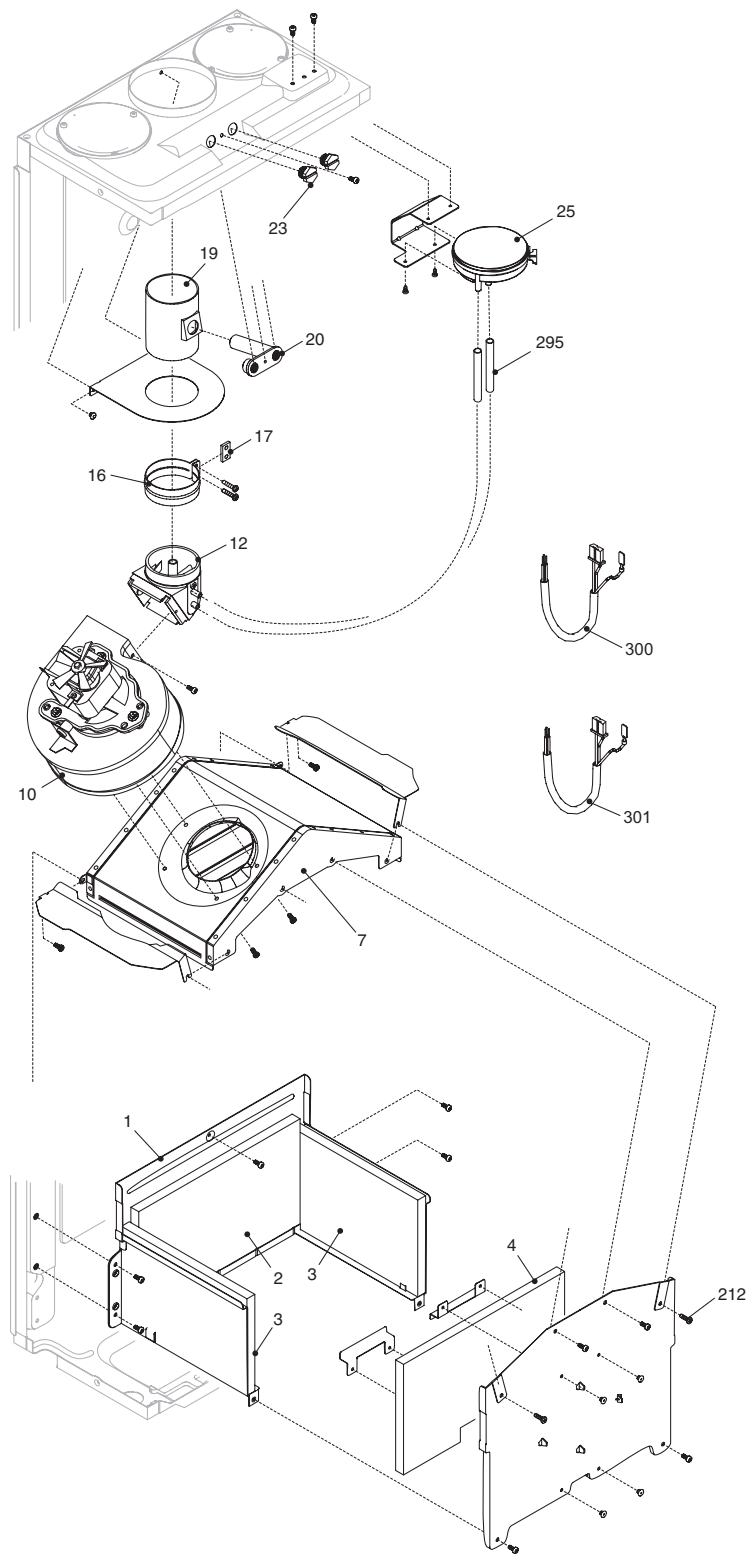

POS.	DESCRIPTION	726	730	735
1	Combustion chamber assembly	R6027	R6028	R10024751
2	Combustion chamber back panel	R5270	R5316	R10020518
3	Combustion chamber lateral panel	R5271	R5271	R5271
4	Combustion chamber front panel	R5269	R5315	R10020517
7	Hood assembly	R2678	R2860	R1968
10	Fan	R2865	R10024526	R10024577
12	Fan to flue connector	R10023048	R10023182	R10023183
16	Clamp for tube	R5916	R5916	R5916
17	Washer clamp	R5917	R5917	R5917
19	Fan flue connection	R8083	R8083	R8083
20	Block with combustion analysis check	R8085	R8085	R8085
23	Brass cap	R8086	R8086	R8086
25	Pressure differential switch	R2677	R2677	R2677
212	Self tapping screw	R5080	R5080	R5080
295	Silicone tube	R1457	R1457	R1457
300	Wiring harness	R10021065	R10021108	R10020529
300	Wiring harness	R1870	R1870	R1870

10.1 RELATED DOCUMENTS

BS 6798		INSTALLATION OF BOILERS OF RATED NOT EXCEEDING 60kW
BS 5449	PART 1	FORCED CIRCULATION OF HOT WATER SYSTEMS
BS 5546		INSTALLATION OF GAS HOT WATER SUPPLIES FOR DOMESTIC PURPOSES
BS 5440	PART 1	FLUES
BS 5482	PART 1	DOMESTIC BUTANE & PROPANE GAS BURNERS IN PERMAMENT DWELLINGS

10.2

Gas Pressures	726	730	735
Inlet pressure (G31)	37 mbar		
Burner pressure maximum	36 mbar		
Burner pressure minimum	4.0 mbar	3.5 mbar	2.8mbar
Maximum gas rate	2.19 kg/h	2.53 kg/h	2.94 kg/h
Minimum gas rate	0.70 kg/h	0.75 kg/h	0.77 kg/h
Injector size (quantity)	12 x 0.8 mm	14 x 0.8 mm	16 x 0.8 mm

10.3 CONVERTING THE APPLIANCE GAS TYPE

To convert the appliance to another gas type it is necessary to change the burner injectors and adjust the gas pressures. It is also necessary to ensure the jumper tag at JP8 is enabled or disabled according to the gas type used.

- To change the injectors see 6.15
- For correct jumper tag configuration see 7.8

10.4 GAS SUPPLY

The gas supply must be connected to the appliance by a competent LPG installer and must be of sufficient size to supply the appliance at its maximum output.

An existing supply must be checked to ensure that it is of adequate size to deal with the maximum rated input of this and any other appliances that it serves.

10.5 GAS SUPPLY INSTALLATION

The entire installation including the meter must be purged and checked for gas soundness.

10.6 CHECKING AND ADJUSTING BURNER PRESSURE (see fig. 16)

Isolate the appliance from the electrical supply and attach a suitable manometer to the gas valve outlet test point.

10.6.1 SETTING THE MAXIMUM BURNER PRESSURE fig. 41

Light the boiler as described in 5.7, fully open a DHW outlet (preferably the bath), and ensure the HW temperature selector is set at maximum. Allow the appliance to stabilise.

Compare the reading on the manometer with the value described in 10.2. If adjustment is required, remove the protective cap from the gas valve modulating coil assembly and turn the outer (10mm) nut clockwise to increase, or counter-clockwise to decrease the burner pressure.

10.6.2 SETTING THE MIMIMUM BURNER PRES-SURE fig. 42

Once the maximum burner pressure has been checked and/or adjusted, remove one of the grey wires from the modulating coil. Compare the reading on the manometer with the value described in 10.2. If adjustment is required, turn the inner (red) crosshead screw clockwise to increase, or counter-clockwise to decrease the burner pressure, whilst ensuring that the outer (10mm) nut does not move. When checking and/or adjustment has been completed, isolate the appliance from the electrical supply, close the DHW outlet, replace the protective cap, refit the grey wire to the modulating coil, remove the manometer, and tighten the outlet test point.

IMPORTANT, A GAS SOUNDNESS CHECK MUST BE CARRIED OUT.



energizing home heating

Vokèra Ltd.

4th Floor, Catherine House, Boundary Way, Hemel Hempstead, Herts, HP2 7RP

Email: enquiries@vokera.co.uk Web: www.vokera.co.uk

Sales, Technical Advice, General Enquiries - Tel: 0870 333 0520 Fax: 01442 281403

After Sales Service - Tel: 0870 333 0220

Vokèra Ireland

West Court, Callan, Co Kilkenny

Tel: 05677 55057 Fax: 05677 55060

Vokèra Ltd. reserve the right to change the specifications without prior notice. Consumers' statutory rights are not affected.

A Riello Group Company



**"Vokèra"
supports Benchmark**