

Linea HE

High efficiency combi boiler

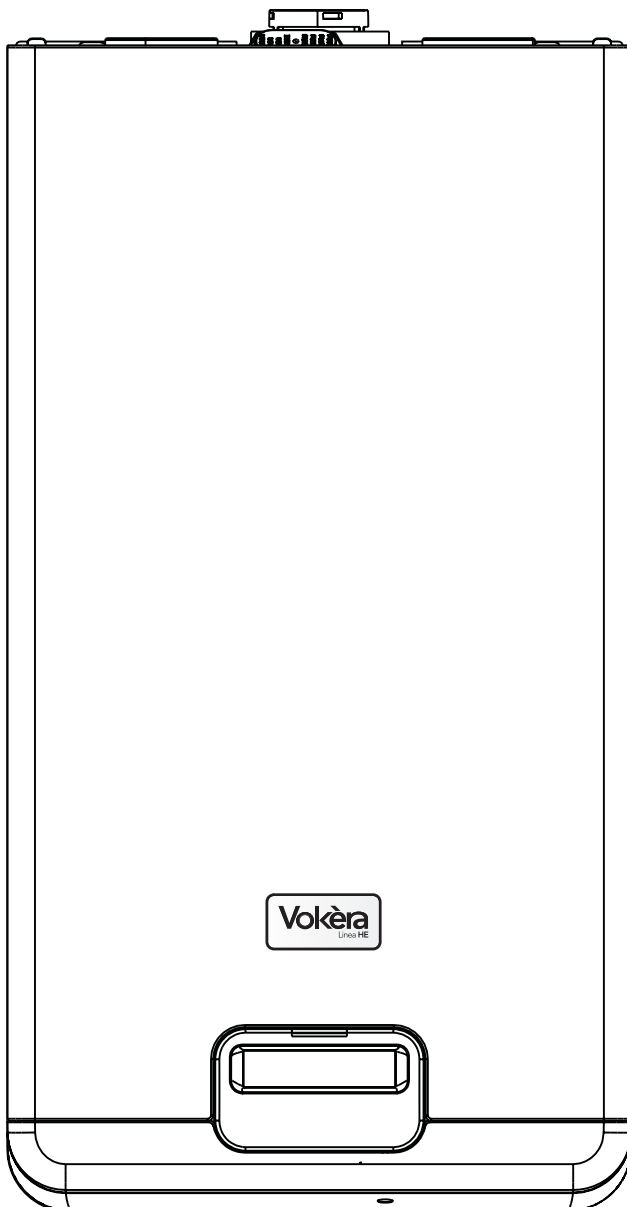

Installation & Servicing Instructions



**THESE INSTRUCTIONS
TO BE RETAINED
BY USER**



Vokèra is a licensed member of the Benchmark scheme which aims to improve the standards of installation and commissioning of domestic hot water systems in the UK.

Contents

Design principles & operating sequence	Page
1.1 Principle components	3
1.2 Mode of operation	3
1.3 Mode of operation (Heating)	3
1.4 Mode of operation (DHW)	3
1.5 Safety devices	3
1.6 Optional accessories	3

Technical data	Page
2.1 Central heating	4
2.2 Domestic hot water	4
2.3 Gas pressure	4
2.4 Expansion vessel	4
2.5 Dimensions	4
2.6 Clearances	4
2.7 Connections	4
2.8 Electrical	4
2.9 Flow rates	4
2.9 Flue details (concentric)	4
2.9A Flue details (twin pipes)	4
2.9B Flue details (80/125)	4
2.10 Efficiency	4
2.11 Emissions	5
2.12 Pump duty	5

General requirements (UK)	Page
3.1 Related documents	6
3.2 Location of appliance	6
3.3 Gas supply	6
3.4 Flue system	6
3.5 Air supply	7
3.6 Water circulation	7
3.7 Electrical supply	7
3.8 Showers	7
3.9 Mounting on a combustible surface	7
3.10 Timber framed buildings	7
3.11 Inhibitors	8

General requirements (EIRE)	Page
3A.1 Related documents	9
3A.2 Location of appliance	9
3A.3 Gas supply	9
3A.4 Flue system	9
3A.5 Air supply	9
3A.6 Water circulation	9
3A.7 Electrical supply	10
3A.8 Showers	10
3A.9 Mounting on a combustible surface	10
3A.10 Timber framed buildings	10
3A.11 Inhibitors	10
3A.12 Declaration of conformity	10

Installation	Page
4.1 Delivery	11
4.2 Contents	11
4.3 Unpacking	11
4.4 Preparation for mounting the appliance	11
4.5 Fitting the flue	11
4.6 Connecting the gas & water	16
4.7 Electrical connections	16

Commissioning	Page
5.1 Gas supply installation	18
5.2 The heating system	18
5.3 Initial filling of the system	18
5.4 Initial flushing of the system	18
5.5 Filling the hot water system	18
5.6 Pre-operation checks	18
5.7 Initial lighting	18
5.8 Final flushing of the heating system	18
5.9 Setting the boiler operating temperature	19
5.10 Setting the system design pressure	19
5.11 Regulating the hot water	19
5.12 Final checks	20
5.13 Instructing the user	20

Servicing	Page
6.1 General	21
6.2 Routine annual servicing	21

6.3 Replacement of components	21
6.4 Component removal procedure	21
6.5 Pump assembly	21
6.6 Safety valve	22
6.7 Bottom automatic air release valves	22
6.8 Water pressure sensor/gauge	22
6.9 Primary thermistors	22
6.10 Return thermistors	22
6.11 Printed circuit board	22
6.12 Gas valve	22
6.13 Electrode and condense sensor	23
6.14 Flue fan & mixer	23
6.15 Burner	23
6.16 Main heat exchanger	23
6.17 Flow restrictor	24
6.18 DHW flow switch	24
6.19 DHW heat exchanger	24
6.20 Valve actuator	24
6.21 Divertor valve assembly	24
6.22 DHW thermistor	24
6.23 Automatic by-pass & DHW non-return valve	24
6.24 Expansion vessel	25
6.25 Condense trap removal	25
6.26 Fan transformer removal	25
6.27 Flue collector removal	25

Checks, adjustments and fault finding	Page
7.1 Checking appliance operation	26
7.2 Appliance mode of operation	26
7.3 Service mode & parameters	27
7.4 Adjusting mode & the gas valve	29
7.5 Combustion analysis test	30
7.6 Checking the expansion vessel	30
7.7 External faults	30
7.8 Electrical checks	30
7.9 Fault finding	30
7.10 Temporary fault codes	31
7.11 Final fault codes	31

Wiring diagrams	Page
8.1 External wiring	32
8.2 Typical control applications	32
8.3 Vokera room thermostat	32
8.4 Other devices	32

Exploded diagrams	Page
9.1 Table 1	35
9.2 Table 2	36
9.3 Table 3	37
9.4 Table 4	38
9.5 Table 5	39

L.P.G. instructions	Page
10.1 Related documents	40
10.2 Technical data	40
10.3 Converting the appliance gas type	40
10.4 Gas supply	40
10.5 Gas supply installation	40
10.6 Adjusting the gas valve	40

Benchmark	41-42
------------------	-------

INTRODUCTION

The Linea HE range of appliances is comprised of 3 models of high-efficiency combination boiler with inputs to heating & DHW of 25 & 30, 30 & 35 and 35&35 kW respectively. Each appliance – by design – incorporates electronic ignition, circulating pump, expansion vessel, safety valve, water pressure sensor and automatic bypass.

The Linea HE range is produced as room sealed, category II2H3P appliances, suitable for internal wall mounting applications only. They are provided with a fan

powered flue outlet with an annular co-axial combustion air intake that can be rotated – horizontally – through 360 degrees for various horizontal or vertical applications. The Linea HE range can also be used with the Vokera twin flue system.

The Linea HE range is approved for use with B23P-B53P-C13-C23-C33-C43-C53-C63-C83 type flue applications.

These appliances are designed for use with a sealed system only; consequently they are not intended for use on open vented systems nor are they intended for external applications.

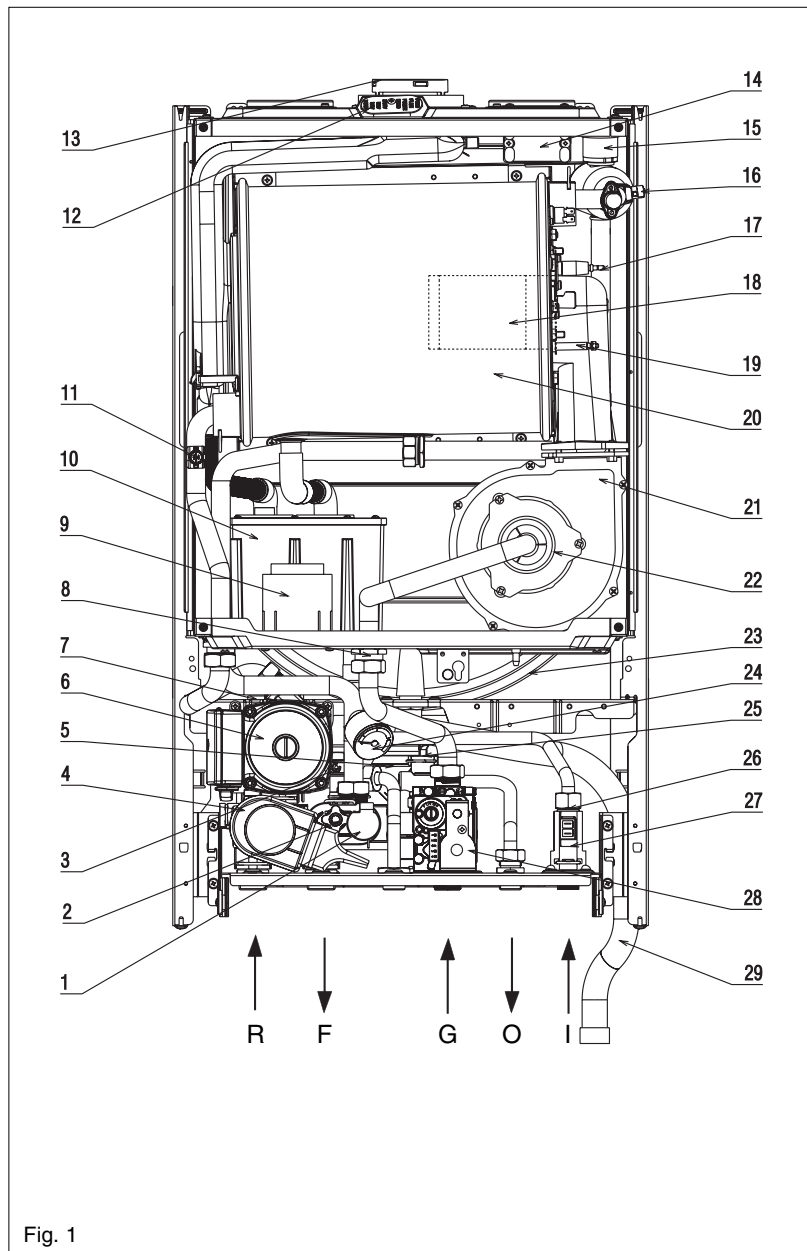

Fig. 1

General layout (fig. 1)

- 1 Water pressure sensor/Transducer
- 2 Drain valve
- 3 Safety valve
- 4 Three port valve actuator
- 5 Domestic hot water heat exchanger
- 6 Pump
- 7 Bottom auto air vent (AAV)
- 8 Injector
- 9 Transformer
- 10 Condense trap
- 11 Return sensor
- 12 Flue gas analysis test point
- 13 Flue outlet & air intake
- 14 Ignition transformer
- 15 Top AAV
- 16 Flow sensor
- 17 Spark/Sensing Electrode
- 18 Cylindric Burner
- 19 Condensate level sensor
- 20 Main heat exchanger
- 21 Fan assembly
- 22 Mixer
- 23 Expansion vessel
- 24 Hydrometer
- 25 Domestic hot water sensor
- 26 Flow governor
- 27 DHW flow switch
- 28 Gas valve
- 29 Condensing drain
- R Heating return connection
- F Heating flow connection
- G Gas connection
- O Hot water outlet
- I Cold water inlet

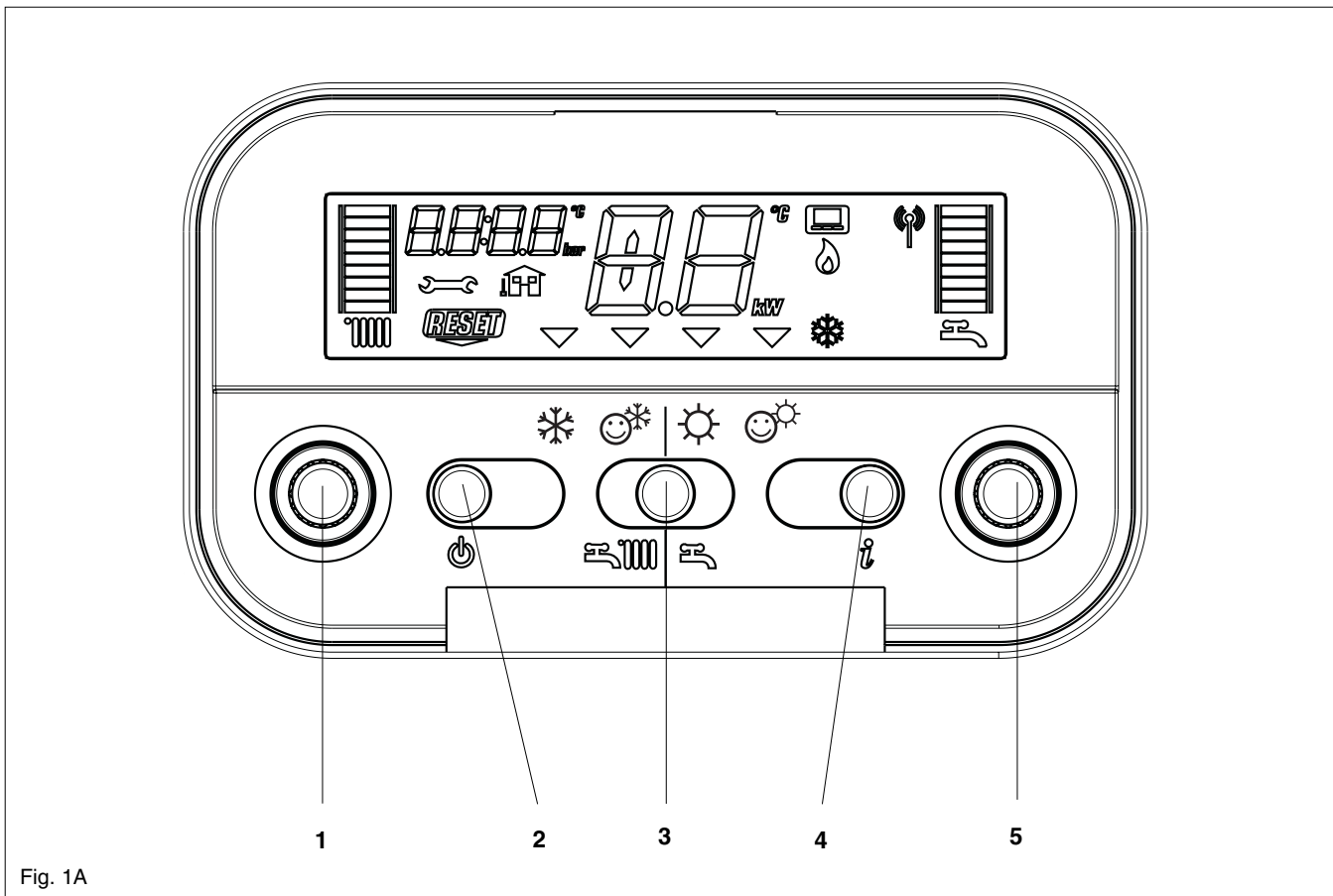

Fig. 1A

- 1= central heating temperature control
- 2= ON/OFF/RESET button
- 3= MODE button
- 4= INFO button
- 5= hot water temperature control

Symbols description

- Summer
- Spring
- Autumn
- Winter
- central heating temperature bar
- hot water temperature bar
- temporary fault indicator
- reset
- current water pressure
- outside sensor
- current appliance temperature
- error code
- current mode of operation
- burner on
- frost protection on

SECTION 1 DESIGN PRINCIPLES AND OPERATING SEQUENCE

1.1 PRINCIPLE COMPONENTS

- A fully integrated electronic control board featuring electronic temperature control, anti-cycle control, pump over-run, self-diagnostic fault indicator and premix burner control
- Low-water-content, aluminium heat exchanger
- Electronic ignition with flame supervision
- Integral high-head pump
- Fan
- Expansion vessel
- Water pressure sensor/gauge
- Two-stage gas valve
- Condensate level sensor
- Safety valve

1.2 MODE OF OPERATION (see section 7 for detailed information)

When the appliance is connected to the electrical supply, there are 5-possible modes of operation:

- STANDBY- Heating and DHW functions are disabled, however anti-freeze and anti-seize functions are active*
- WINTER - Heating and DHW functions enabled with DHW pre-heat and SARA BOOSTER function active
- SPRING - DHW only enabled, DHW pre-heat disabled
- SUMMER - DHW only enabled, DHW pre-heat disabled, TSC function enabled
- AUTUMN - Heating and DHW functions enabled, DHW pre-heat disabled, SARA function active.

*Anti-freeze & anti-seize functions are active in all operating modes.

1.3 MODE OF OPERATION (Heating)

When there is a request for heat via the programmer/time clock and/or any external control, the pump and fan are started, the fan speed will modulate until the correct signal voltage is received at the control PCB. At this point an ignition sequence is enabled.

Ignition is sensed by the electronic circuitry to ensure flame stability at the burner. Once successful ignition has been achieved, the electronic circuitry increases the gas rate to 75% for a period of 15 minutes (adjustable, see parameter 28, cap. 7.3.1). Thereafter, the boiler's output will either increase to maximum or modulate to suit the set requirement. When the appliance reaches the desired temperature the burner will shut down and the boiler will perform a five-minute anti-cycle (timer delay). When the request for heat has been satisfied the appliance pump and fan may continue to operate to dissipate any residual heat within the appliance.

1.4 MODE OF OPERATION (DHW)

When there is a request for DHW via a hot water outlet or tap, the pump and fan are started, the fan speed will modulate until the correct signal voltage is received at the control PCB. At this point an ignition sequence is enabled.

Ignition is sensed by the electronic circuitry to ensure flame stability at the burner. Once successful ignition has been achieved, the electronic circuitry increases the gas rate to maximum or will modulate output to stabilise the temperature.

In the event of the appliance exceeding the desired temperature (set point) the burner will shut

down until the temperature drops*.

When the request for DHW has been satisfied the appliance pump and fan may continue to operate to dissipate any residual heat within the appliance.

*When the appliance is in the SUMMER mode, the burner will remain on minimum power even if the set point has been achieved.

1.5 SAFETY DEVICES

When the appliance is in use, safe operation is ensured by:

- a water pressure sensor that monitors system water pressure and will de-activate the pump, fan, and burner should the system water pressure drop below the rated tolerance;
- 2 temperature sensors that control and prevent the over-heating of the circuit, interrupting the operation of the burner;
- a differential temperature protection circuit which interrupts the burner if the temperature differential is too high or inverted;
- a fan speed sensor that checks the correct operation of the fan, thereby allowing safe operation of the burner;
- a sensor that interrupts the operation of the appliance if the condense pipe becomes blocked;
- a safety valve which releases excess pressure from the primary circuit.

1.6 OPTIONAL ACCESSORIES

The Linea HE is suitable for use with a range of optional accessories that enable enhanced operation and/or applications. These include:

- external sensor that enables the appliance to automatically adjust its outlet flow temperature in response to the outside temperature
- RF wireless room thermostat.

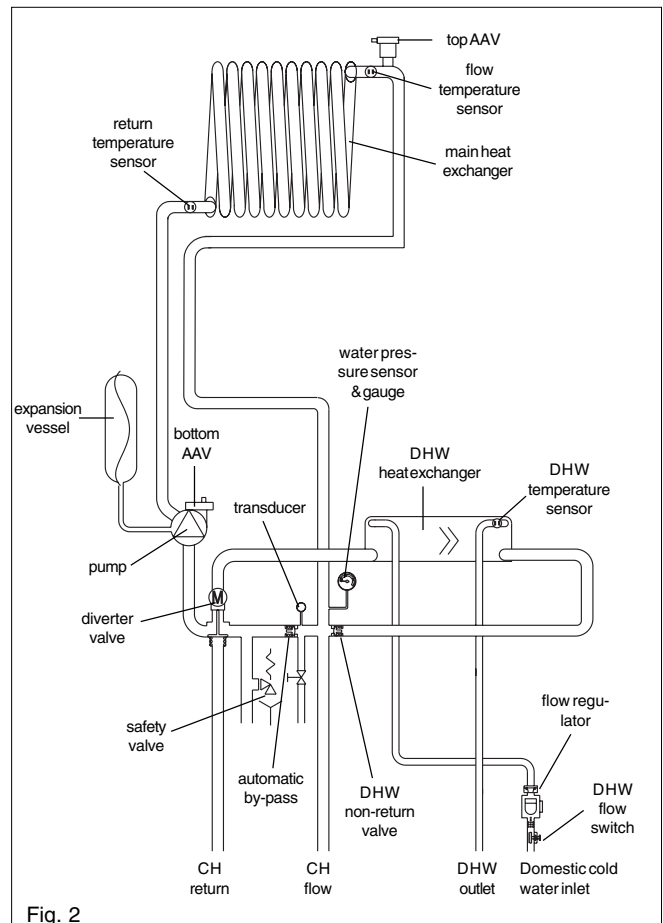

Fig. 2

SECTION 2 TECHNICAL DATA

2.1 Central Heating	Linea 28HE	Linea 32HE	Linea 36HE
Heat input (kW)	25.0	30.0	34.6
Maximum heat output @ 60/80 °C (kW)	24.4	29.4	33.7
Maximum heat output @ 30/50 °C (kW)	26.1	31.9	36.7
Minimum heat output @ 60/80 °C (kW)	5.9	6.9	6.9
Minimum heat output @ 30/50 °C (kW)	6.4	7.6	7.6
Minimum working pressure	0.5 bar		
Maximum working pressure	3 bar		
Minimum flow rate	350 litres per hour		
2.2 Domestic Hot Water			
Maximum input (kW)	30.0	34.6	34.6
Maximum output (kW)	30.0	34.6	34.6
Minimum input (kW)	6.0	7.0	7.0
Flow rate (35 °C rise)	12.3	14.2	14.2
Maximum inlet pressure	6.0 bar		
Minimum inlet pressure	0.15 bar		
Minimum flow rate	2.0 l/min		
2.3 Gas Pressures			
Inlet pressure (G20)	20.0 mbar		
Maximum gas rate (m ³ /hr)	3.17	3.66	3.66
Minimum gas rate (m ³ /hr)	0.63	0.74	0.74
Injector size	6.7mm	7.0mm	7.0mm
Fan speed @ max output (rpm) DHW	5.900	6.000	6.000
Fan speed @ max output (rpm) HTG	4.900	5.500	
Fan speed @ min output (rpm)	1.400	1.400	1.400
2.4 Expansion Vessel			
Capacity	10 litres	10 litres	10 litres
Maximum system volume	91 litres	91 litres	91 litres
Pre-charge pressure	1.0 bar		
2.5 Dimensions			
Height	845 mm		
Width	453 mm		
Depth	358 mm		
Dry weight (Kg)	42.0	44.0	45.0
2.6 Clearances			
Sides	12 mm		
Top	150 mm from casing or 25 mm above flue elbow (whichever is applicable)		
Bottom	150 mm		
Front	600 mm		
2.7 Connections			
Flow & return	22 mm		
Hot & cold water	15 mm		
Gas	15 mm		
Safety valve	15 mm		
Condense	21 mm		
2.8 Electrical			
Voltage (V/Hz)	230/50hz		
Power consumption (W)	130	130	175
Internal fuse	2A		
External fuse	3A		
2.9 Flue details (concentric)			
Maximum horizontal flue length (60/100mm)	7.80m	7.80m	7.80m
Maximum vertical flue length (60/100mm)	8.80m	8.80m	8.80m
2.9A Flue details (twin pipes)			
Maximum horizontal flue length (80mm+80mm)	40m+40m	35m+35m	50m+50m
Maximum vertical flue length (80mm+80mm)	40m+40m	35m+35m	50m+50m
2.9B Flue details (80/125mm)			
Maximum horizontal flue length (80/125mm)	17m	25m	28m
Maximum vertical flue length (80/125mm)	18m	26m	29m
2.10 Efficiency			
SEDBUK (%)	90.1 (A)	90.3 (A)	90.0 (A)
NOx class	5	5	5

2.11 Emissions	Linea 28HE	Linea 32HE	Linea 36HE
NOx (max-min)	88,3 - 70,6 mg/kWh	88,3-61,8 mg/kWh	123,5 - 105,9 mg/kWh
CO (max-min)	193,5 - 43 mg/kWh	215 - 21,5 mg/kWh	268,8 - 43 mg/kWh
CO ₂ (max-min)	9.0 - 9.30 %	9.0 - 9.0 %	9.0 - 9.0 %
CO/CO ₂ ratio (max)	0.002 to 1	0.002 to 1	0.002 to 1
CO/CO ₂ ratio (min)	0.0004 to 1	0.0004 to 1	0.0004 to 1

Ref. Condition 15 °C, 1013,25 mbar, dry gas
NOTE: L.P.G. data refer to section 10

2.12 PUMP DUTY

Fig. 3 shows the flow rate available – after allowing for pressure loss through the appliance – for system requirements. When using this graph apply only the pressure loss of the system. The graph is based on 20 °C temperature differential.

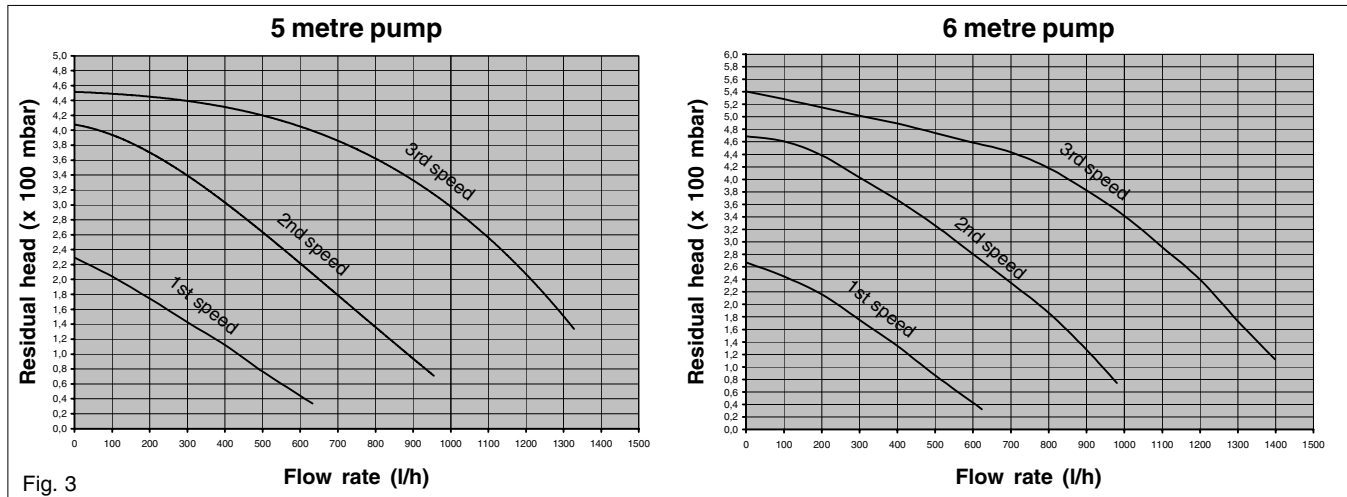
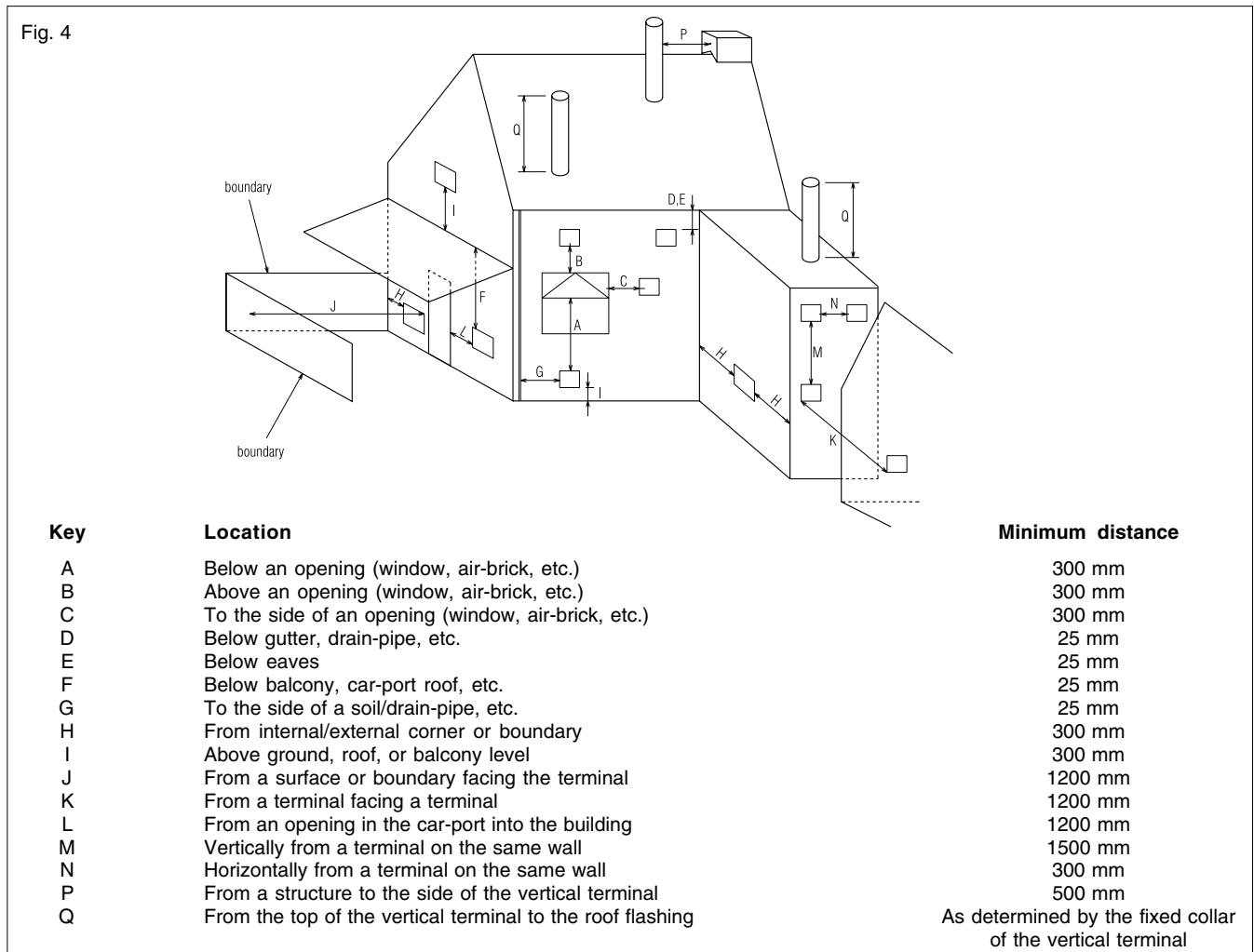

Fig. 3



SECTION 3 GENERAL REQUIREMENTS (UK)

This appliance must be installed by a competent person in accordance with the Gas Safety (Installation & Use) Regulations.

3.1 RELATED DOCUMENTS

The installation of this boiler must be in accordance with the relevant requirements of the Gas Safety (Installation & Use) Regulations, the local building regulations, the current I.E.E. wiring regulations, the bylaws of the local water undertaking, the Building Standards (Scotland) Regulation and Building Standards (Northern Ireland) Regulations. It should be in accordance also with any relevant requirements of the local authority and the relevant recommendations of the following British Standard Codes of Practice.

3.2 LOCATION OF APPLIANCE

The appliance may be installed in any room or internal space, although particular attention is drawn to the requirements of the current I.E.E. wiring regulations, and in Scotland, the electrical provisions of the Building Regulations, with respect to the installation of the appliance in a room or internal space containing a bath or shower. When an appliance is installed in a room or internal

space containing a bath or shower, the appliance or any control pertaining to it must not be within reach of a person using the bath or shower. The location chosen for the appliance must permit the provision of a safe and satisfactory flue and termination. The location must also permit an adequate air supply for combustion purposes and an adequate space for servicing and air circulation around the appliance. Where the installation of the appliance will be in an unusual location special procedures may be necessary, BS 6798 gives detailed guidance on this aspect. A compartment used to enclose the appliance must be designed and constructed specifically for this purpose. An existing compartment/cupboard may be utilised provided that it is modified to suit. Details of essential features of compartment/cupboard design including airing cupboard instal-

3.3 GAS SUPPLY

The gas meter – as supplied by the gas supplier – must be checked to ensure that it is of adequate size to deal with the maximum rated input of all the appliances that it serves. Installation pipes must be fitted in accordance with BS 6891.

Pipe work from the meter to the appliance must be of adequate size. Pipes of a smaller size than the appliance gas inlet connection must not be used. The installation must be tested for soundness in accordance with BS6891.

If the gas supply serves more than one appliance, it must be ensured that an adequate supply is maintained to each appliance when they are in use at the same time.

3.4 FLUE SYSTEM

The terminal should be located where the disper-

BS 5440	PART 1	FLUES
BS 5440	PART 2	FLUES & VENTILATION
BS 5449	PART 1	FORCED CIRCULATION HOT WATER SYSTEMS
BS 5546		INSTALLATION OF GAS HOT WATER SUPPLIES FOR DOMESTIC PURPOSES (2nd FAMILY GASES)
BS 6798		INSTALLATION OF BOILERS OF RATED INPUT NOT EXCEEDING 60kW
BS 6891		LOW PRESSURE INSTALLATION PIPES
BS 7074	PART 1	APPLICATION, SELECTION AND INSTALLATION OF EXPANSION VESSELS AND ANCILLARY EQUIPMENT FOR SEALED WATER SYSTEMS

sal of combustion products is not impeded and with due regard for the damage and discoloration that may occur to building products located nearby. The terminal must not be located in a place where it is likely to cause a nuisance (fig. 4).

In cold and/or humid weather, water vapour will condense on leaving the terminal; the effect of such plumbing must be considered.

If installed less than 2m above a pavement or platform to which people have access (including balconies or flat roofs) the terminal must be protected by a guard of durable material. The guard must be fitted centrally over the terminal. Refer to BS 5440 Part 1, when a terminal is sited less than 1m below a plastic gutter, or less than 500mm below a painted surface, a suitable one metre long heat shield should be fitted.

Details of essential features of compartment/cupboard design including airing cupboard instal-

3.5 AIR SUPPLY

The following notes are intended for general guidance only.

This appliance is a room-sealed, fan-flued boiler, consequently it does not require a permanent air vent for combustion air supply.

When installed in a cupboard or compartment, ventilation for cooling purposes is also not required.

3.6 WATER CIRCULATION

Detailed recommendations are given in BS 5449 Part 1 and BS 6798. The following notes are for general guidance only.

3.6.1 PIPEWORK

It is recommended that copper tubing to BS 2871 Part 1 is used in conjunction with soldered capillary joints. Where possible pipes should have a gradient to ensure air is carried naturally to air release points and that water flows naturally to drain cocks.

Except where providing useful heat, pipes should be insulated to avoid heat loss and in particular to avoid the possibility of freezing. Particular attention should be paid to pipes passing through ventilated areas such as under floors, loft space, and void areas.

3.6.2 AUTOMATIC BY-PASS

The appliance has a built-in automatic by-pass. However it may be necessary to fit an external by-pass should the design of the heating system require such. In any case, the design of the system should be such that it prevents boiler 'cycling'.

3.6.3 DRAINCOCKS

These must be located in accessible positions to facilitate draining of the appliance and all water pipes connected to the appliance. The drain cocks must be manufactured in accordance with BS 2879.

3.6.4 AIR RELEASE POINTS

These must be positioned at the highest points in the system where air is likely to be trapped. They should be used to expel trapped air and allow complete filling of the system.

3.6.5 EXPANSION VESSEL

The appliance has an integral expansion vessel to accommodate the increased volume of water when the system is heated. It can accept up to 10 litres within the system, generally this is sufficient, however if the system has an unusually high water content, it may be necessary to provide additional expansion capacity (see 6.24).

3.6.6 FILLING POINT

A method for initial filling of the system and replacing water lost during servicing etc. has been provided. This method of filling complies with the current Water Supply (Water Fittings) Regulations 1999 and Water Bylaws 2000 (Scotland).

3.6.7 LOW PRESSURE SEALED SYSTEM

An alternative method of filling the system would be from an independent make-up vessel or tank mounted in a position at least 1-metre above the highest point in the system and at least 5-metres above the boiler (see fig. 5). The cold feed from the

make-up vessel or tank must be fitted with an approved non-return valve and stopcock for isolation purposes. The feed pipe should be connected to the return pipe as close to the boiler as possible.

3.6.8 FREQUENT FILLING

Frequent filling or venting of the system may be indicative of a leak. Care should be taken during the installation of the appliance to ensure all aspects of the system are capable of withstanding pressures up to at least 3 bar.

3.7 ELECTRICAL SUPPLY

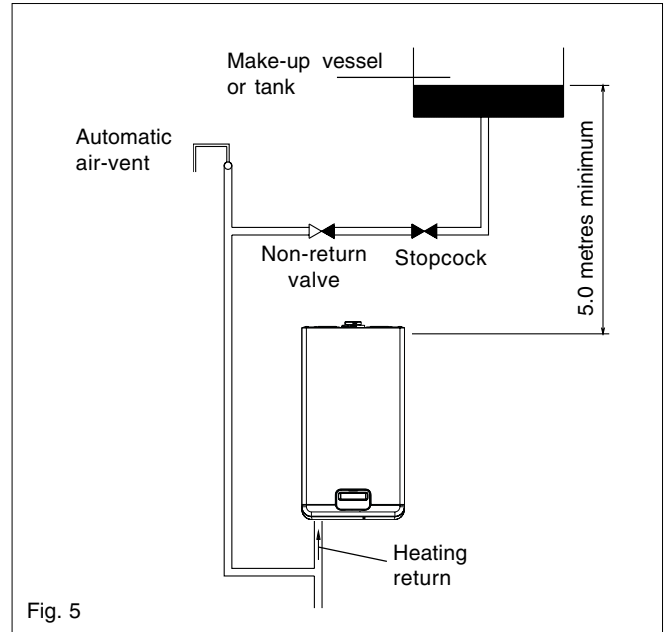

Fig. 5

The appliance is supplied for operation on 230V @ 50Hz electrical supply; it must be protected with a 3-amp fuse. The method of connection to the mains electricity supply must allow for complete isolation from the supply. The preferred method is by using a double-pole switch with a contact separation of at least 3mm. The switch must only supply the appliance and its corresponding controls, i.e. time clock, room thermosta, etc. Alternatively an un-switched shuttered socket with a fused 3-pin plug both complying with BS 1363 is acceptable.

3.8 SHOWERS

If the appliance is intended for use with a shower, the shower must be thermostatically controlled and be suitable for use with a combination boiler.

3.9 MOUNTING ON A COMBUSTIBLE SURFACE

If the appliance is to be fitted on a wall of combustible material, a sheet of fireproof material must protect the wall.

3.10 TIMBER FRAMED BUILDINGS

If the appliance is to be fitted in a timber framed building, it should be fitted in accordance with the Institute of Gas Engineers publication (IGE/UP/7) "Guide for Gas Installations in Timber Frame Buildings".

SECTION 3A GENERAL REQUIREMENTS (EIRE)

This appliance must be installed by a competent person in accordance with and defined by, the Standard Specification (Domestic Gas Installations) Declaration (I.S. 813).

3A.1 RELATED DOCUMENTS

The installation of this boiler must be in accordance with the relevant requirements of the local building regulations, the current ETCI National Rules for Electrical Installations, and the bylaws of the local water undertaking.

It should be in accordance also with any relevant requirements of the local and/or district authority.

3A.2 LOCATION OF APPLIANCE

The appliance may be installed in any room or internal space, although particular attention is drawn to the requirements of the current ETCI National Rules for Electrical Installations, and I.S. 813, Annex K.

When an appliance is installed in a room or internal space containing a bath or shower, the appliance or any control pertaining to it must not be within reach of a person using the bath or shower.

The location chosen for the appliance must permit the provision of a safe and satisfactory flue and termination. The location must also permit an adequate air supply for combustion purposes and an adequate space for servicing and air circulation around the appliance. Where the installation of the appliance will be in an unusual location special procedures may be necessary, refer to I.S. 813 for detailed guidance on this aspect.

A compartment used to enclose the appliance must be designed and constructed specifically for this purpose. An existing compartment/cupboard may be utilised provided that it is modified to suit. This appliance is not suitable for external installation.

3A.3 GAS SUPPLY

The gas meter – as supplied by the gas supplier – must be checked to ensure that it is of adequate size to deal with the maximum rated input of all the appliances that it serves. Installation pipes must be fitted in accordance with I.S. 813.

Pipe work from the meter to the appliance must be of adequate size. Pipes of a smaller size than the appliance gas inlet connection must not be used. The installation must be tested for soundness in accordance with I.S. 813.

If the gas supply serves more than one appliance, it must be ensured that an adequate supply is maintained to each appliance when they are in use at the same time.

3A.4 FLUE SYSTEM

The terminal should be located where the dispersal of combustion products is not impeded and with due regard for the damage and discoloration that may occur to building products located nearby. The terminal must not be located in a place where

it is likely to cause a nuisance (see I.S. 813).

In cold and/or humid weather, water vapour will condense on leaving the terminal; the effect of such plumbing must be considered.

If installed less than 2m above a pavement or platform to which people have access (including balconies or flat roofs) the terminal must be protected by a guard of durable material. The guard must be fitted centrally over the terminal. Refer to I.S. 813, when the terminal is 0.5 metres (or less) below plastic guttering or 1 metre (or less) below painted eaves.

3A.5 AIR SUPPLY

The following notes are intended for general guidance only.

This appliance is a room-sealed, fan-flued boiler, consequently it does not require a permanent air vent for combustion air supply.

When installed in a cupboard or compartment, ventilation for cooling purposes is also not required.

3A.6 WATER CIRCULATION

Specific recommendations are given in I.S. 813. The following notes are for general guidance only.

3A.6.1 PIPEWORK

It is recommended that copper tubing be used in conjunction with soldered capillary joints.

Where possible pipes should have a gradient to ensure air is carried naturally to air release points and that water flows naturally to drain cocks.

Except where providing useful heat, pipes should be insulated to avoid heat loss and in particular to avoid the possibility of freezing. Particular attention should be paid to pipes passing through ventilated areas such as under floors, loft space, and void areas.

3A.6.2 AUTOMATIC BY-PASS

The appliance has a built-in automatic by-pass. However it may be necessary to fit an external bypass should the design of the heating system require such. In any case, the design of the system should be such that it prevents boiler 'cycling'.

3A.6.3 DRAIN COCKS

These must be located in accessible positions to facilitate draining of the appliance and all water pipes connected to the appliance.

3A.6.4 AIR RELEASE POINTS

These must be positioned at the highest points in the system where air is likely to be trapped. They should be used to expel trapped air and allow complete filling of the system.

3A.6.5 EXPANSION VESSEL

The appliance has an integral expansion vessel to accommodate the increased volume of water when the system is heated. It can accept up to 10 litres within the system, generally this is sufficient,

however if the system has an unusually high water content, it may be necessary to provide additional expansion capacity (see 6.24).

3A.6.6 FILLING POINT

A method for initial filling of the system and replacing water lost during servicing etc. has been provided. You should ensure this method of filling complies with the local water authority regulations.

3A.6.7 LOW PRESSURE SEALED SYSTEM

An alternative method of filling the system would be from an independent make-up vessel or tank mounted in a position at least 1-metre above the highest point in the system and at least 5-metres above the boiler (see fig. 5).

The cold feed from the make-up vessel or tank must be fitted with an approved non-return valve and stopcock for isolation purposes. The feed pipe should be connected to the return pipe as close to the boiler as possible.

3A.6.8 FREQUENT FILLING

Frequent filling or venting of the system may be indicative of a leak. Care should be taken during the installation of the appliance to ensure all aspects of the system are capable of withstanding pressures up to at least 3 bar.

3A.7 ELECTRICAL SUPPLY

The appliance is supplied for operation on 230V @ 50Hz electrical supply; it must be protected with a 3-amp fuse. The method of connection to the mains electricity supply must allow for complete isolation from the supply. The preferred method is by using a double-pole switch with a contact separation of at least 3mm. The switch must only supply the appliance and its corresponding controls, i.e. time clock, room thermostat, etc.

3A.8 SHOWERS

If the appliance is intended for use with a shower, the shower must be thermostatically controlled and be suitable for use with a combination boiler.

3A.9 MOUNTING ON A COMBUSTIBLE SURFACE

If the appliance is to be fitted on a wall of combustible material, a sheet of fireproof material must protect the wall.

3A.10 TIMBER FRAMED BUILDINGS

If the appliance is to be fitted in a timber framed building, it should be fitted in accordance with I.S. 813 and local Building Regulations.

The Institute of Gas Engineers publication (IGE/UP/7) 'Guide for Gas Installations in Timber Frame Buildings' gives specific advice on this type of installation.

3A.11 INHIBITORS

Vokera recommend that an inhibitor - suitable for use with copper and aluminium heat exchangers - is used to protect the boiler and system from the effects of corrosion and/or electrolytic action.

The inhibitor must be administered in strict

accordance with the manufacturers' instructions*.

*Water treatment of the complete heating system - including the boiler - should be carried out in accordance with I.S. 813 and the Domestic Water Treatment Association's (DWTA) code of practice.

3A.12 DECLARATION OF CONFORMITY

A Declaration of Conformity (as defined in I.S. 813) must be provided on completion of the installation.

A copy of the declaration must be given to the responsible person and also to the gas supplier if required.

SECTION 4 INSTALLATION

4.1 DELIVERY

Due to the weight of the appliance it may be necessary for two people to lift and attach the appliance to its mounting. The appliance is contained within a heavy-duty cardboard carton. Lay the carton on the floor with the writing the correct way up.

4.2 CONTENTS

Contained within the carton is:

- the boiler
- the wall bracket & fixing jig
- template
- an accessories pack containing appliance service connections and washers
- the instruction pack containing the installation & servicing instructions, user instructions, guarantee registration card and a 3-amp fuse.

4.3 UNPACKING

At the top of the carton pull both sides open – do not use a knife – unfold the rest of the carton from around the appliance, carefully remove all protective packaging from the appliance and lay the accessories etc. to one side. Protective gloves should be used to lift the appliance, the appliance back-frame should be used for lifting points.

4.4 PREPARATION FOR MOUNTING THE APPLIANCE

The appliance should be mounted on a smooth, vertical, non-combustible surface, which must be capable of supporting the full weight of the appliance. Care should be exercised when determining the position of the appliance with respect to hidden obstructions such as pipes, cables, etc.

When the position of the appliance has been decided – using the template supplied – carefully mark the position of the wall-mounting bracket (see fig. 6-6A) and flue-hole (if applicable). If you intend to run the pipe-work vertically behind the boiler, move the screws on the fixing jig from the default position (No. 3) to position No. 5. You will also require a spacer kit, part No. 435 (see 4.6).

4.5 FITTING THE FLUE

The top flue outlet permits both horizontal and vertical flue applications to be considered, alternatively, the Vokera twin flue system can be utilised if longer flue runs are required.

4.5.1 CONCENTRIC HORIZONTAL FLUE

(For concentric vertical flue, see 4.5.2).

(For twin flue applications, see 4.5.3).

The appliance can be used with either the Vokera condensing 60/100mm concentric flue system or the optional 80/125mm concentric flue system.

NOTE

These instructions relate **only** to the Vokera condensing 60/100mm concentric flue system. For specific details on the installation of the 80/125mm concentric flue system please refer to the instructions supplied.

The appliance flue outlet elbow can be rotated through 360° on its vertical axis. In addition the flue may be extended from the outlet elbow in the

horizontal plane (see 2.9). A reduction must also be made to the maximum length (see table below) when additional bends are used.

Reduction for additional bends

Bend	Reduction in maximum flue length for each bend
45° bend	0.5 metre
90° bend	1.0 metre

Horizontal flue terminals and accessories

Part No.	Description	Length
520	Horizontal flue kit	900mm
521	Telescopic flue kit	350/530mm
522	Plume management kit	1370mm
523	90-degree bend	N/A
524	45-degree bends (pair)	N/A
525	500mm extension	500mm
526	1000mm extension	1000mm
527	2000m extension	2000mm
528	Telescopic extension	350/730mm
529	Wall bracket pack (5)	208mm

Using the template provided, mark and drill a 115mm hole for the passage of the flue pipe. The hole should be drilled to ensure any condense fluid that forms, is allowed to drain back to the appliance (see fig. 7A).

The fixing holes for the wall-mounting bracket/fixing jig should now be drilled and plugged, an appropriate type and quantity of fixing should be used to ensure that the bracket is mounted securely. Once the bracket has been secured to the wall, mount the appliance onto the bracket.

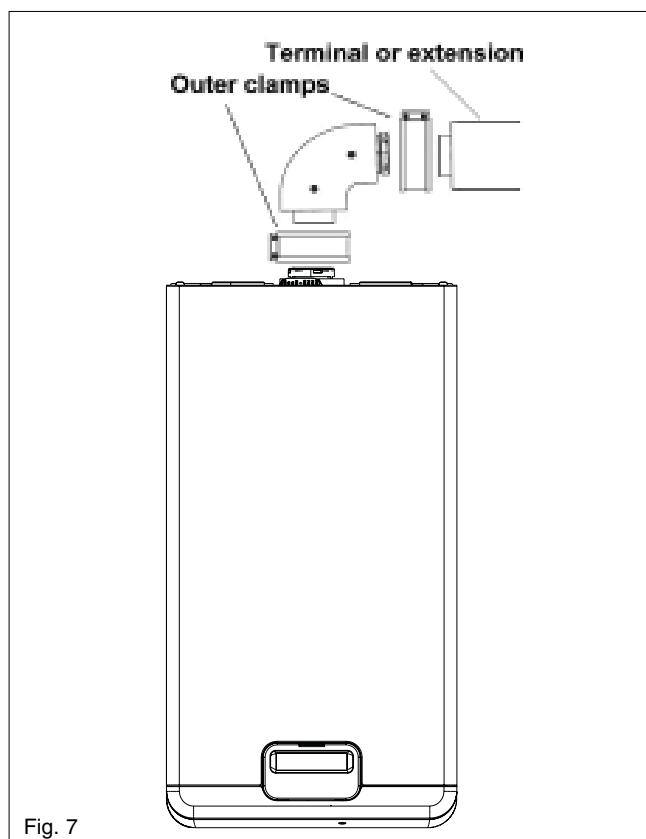

FITTING THE HORIZONTAL FLUE KIT

Carefully measure the distance from the centre of the appliance flue outlet to the edge of the finished outside wall (dimension X). Add 65mm to dimension X to give you Dimension Y (see fig 9A). Measure dimension Y from the terminal end of the concentric flue pipe and cut off the excess ensuring any burrs are removed. Pass the concentric flue pipe through the previously drilled hole. Fit the flue bend to the boiler flue outlet and insert the concentric flue pipe into the flue bend ensuring the correct seal is made. Using the clamp, gasket, and screws supplied, secure the flue bend to the appliance flue spigot.

NOTE

Fit the internal (white) trim to the flue assembly prior to connecting the flue pipe to the bend. You must ensure that the entire flue system is properly supported and connected. Seal the flue assembly to the wall using cement or a suitable alternative that will provide satisfactory weatherproofing. The exterior trim can now be fitted.

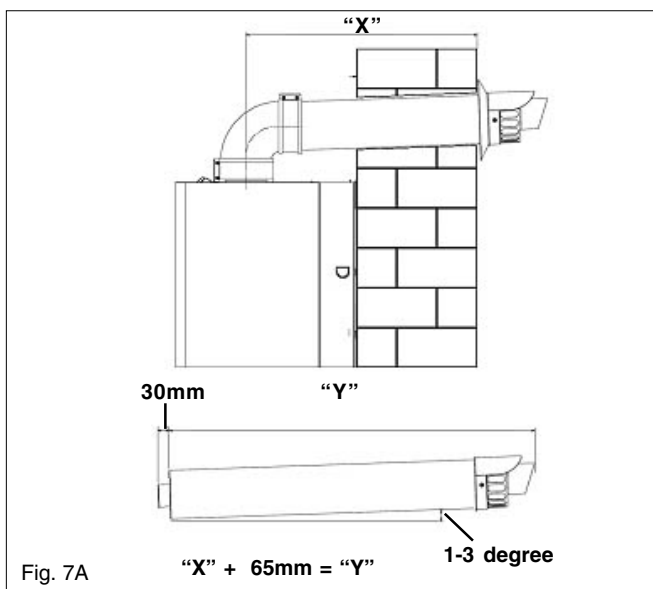

Fig. 7A

4.5.1.1 EXTENDING THE FLUE

Connect the bend – supplied with the terminal kit – to the top of the boiler using clamp (supplied) see fig. 7. The additional bends & extensions have push-fit connections, care should be taken to ensure that the correct seal is made when assembling the flue system. Connect the required number of flue extensions or bends (up to the maximum equivalent flue length) to the flue terminal (see fig. 7 & 8). The flue system should have a minimum of 1°; maximum of 3° rise from the boiler to outside, to ensure any condense fluid that forms, is allowed to drain back to the appliance.

NOTE

When cutting an extension to the required length, you must ensure that the excess is cut from the plain end of the extension (see fig. 7 & 8). Remove any burrs, and check that all seals are located properly. You must ensure that the entire flue system is properly supported and connected. Seal the flue assembly to the wall using cement or a suitable alternative that will provide satisfactory weatherproofing. The interior and exterior trim can now be fitted.

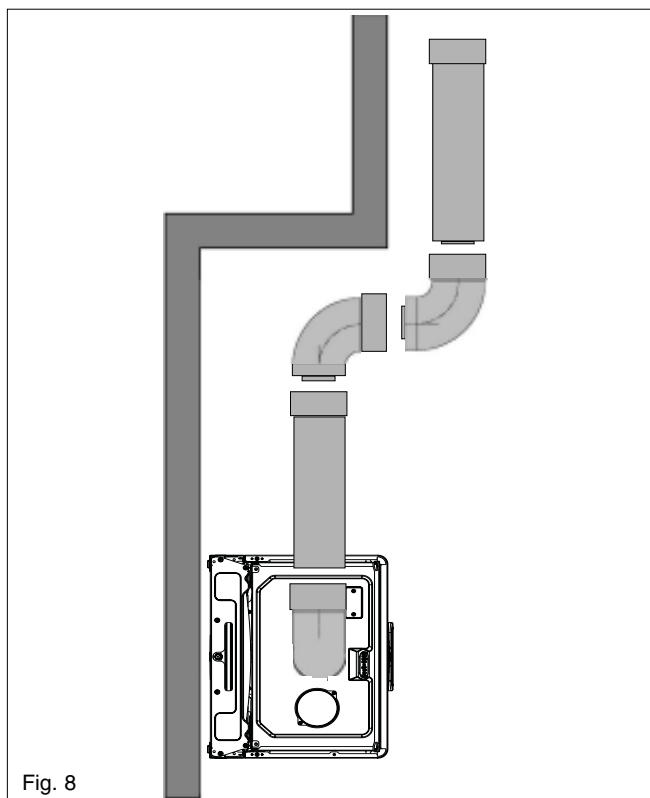

Fig. 8

4.5.2 CONCENTRIC VERTICAL FLUE

The appliance can be used with either the Vokera condensing 60/100mm concentric flue system or the optional 80/125mm concentric flue system.

NOTE

These instructions relate **only** to the Vokera condensing 60/100mm concentric flue system. For specific details on the installation of the 80/125mm concentric flue system please refer to the instructions supplied.

The vertical flue terminal can be connected directly to the appliance flue outlet. Alternatively, an extension or bend can be connected to the appliance flue outlet if desired (see 4.4.2), however if additional bends are fitted, a reduction must be made to the maximum flue length (see table below).

Reduction for bends

Bend	Reduction in maximum flue length for each bend
45° bend	0.5 metre
90° bend	1.0 metre

Vertical flue terminal and accessories

Part No.	Description	Length
530	Vertical flue terminal	1000mm
531	Pitched roof flashing plate	N/A
532	Flat roof flashing plate	N/A
523	90-degree bend	N/A
524	45-degree bends (pair)	N/A
525	500mm extension	500mm
526	1000mm extension	1000mm
527	2000mm extension	2000mm
528	Telescopic extension	350/730mm
529	Wall bracket pack (5)	208mm

Using the dimensions given in fig. 7 as a reference, mark and cut a 115mm hole in the ceiling and/or roof.

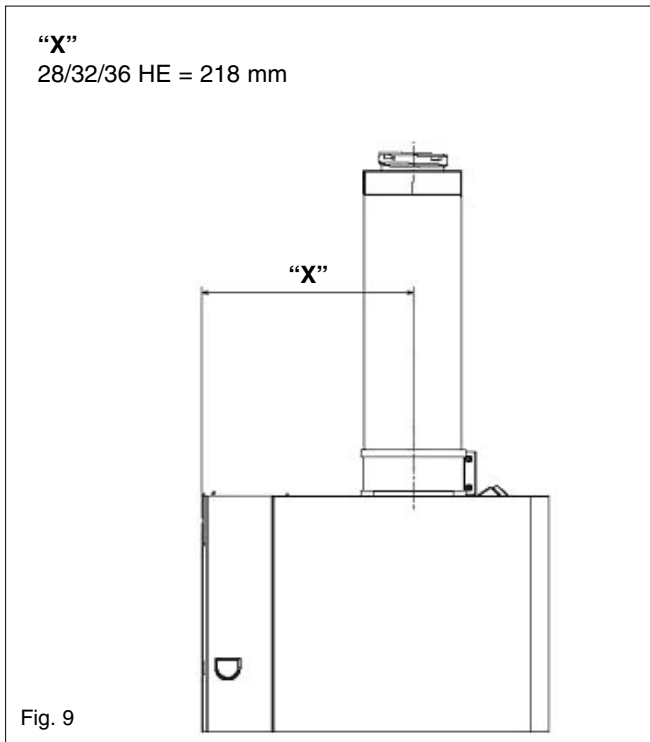

Fit the appropriate flashing plate to the roof and insert the vertical flue terminal through the flashing plate from the outside, ensuring that the collar on the flue terminal fits over the flashing.

The fixing holes for the wall-mounting bracket/fixing jig should now be drilled and plugged, an appropriate type and quantity of fixing should be used to ensure that the bracket is mounted securely. Once the bracket has been secured to the wall, mount the appliance onto the bracket.

IMPORTANT

The vertical flue terminal is 1.0 metre in length and cannot be cut; therefore it may be necessary to adjust the height of the appliance to suit or use a suitable extension.

Connect the vertical flue assembly to the boiler flue spigot using the 100mm clip, gasket & screws (supplied), ensuring the correct seal is made. The flue support bracket (supplied with the vertical flue kit) can now be fitted.

If the vertical flue requires extension/s or additional bend/s, connect the required number of flue extensions or bends (up to the maximum equivalent flue length) between the boiler and vertical flue assembly (see fig. 8).

Ensure that any horizontal sections of the flue system have a minimum 1°; maximum 3° fall back to the boiler (1° = 17mm per 1000mm).

NOTE

When cutting an extension to the required length, you must ensure that the excess is cut from the plain end of the extension (see fig. 6). Remove any burrs, and check that any seals are located properly.

You must ensure that the entire flue system is properly supported and connected.

4.5.3 TWIN FLUE SYSTEM

The Vokera twin flue system enables greater flue distances to be achieved (see 4.4.2) than that of a concentric flue system. It can be used for horizontal or vertical applications, however the twin flue system must be converted to the dedicated concentric flue kit for termination. It is essential that the installation of the twin flue system be carried out in strict accordance with these instructions.

GUIDANCE NOTES ON TWIN FLUE INSTALLATION

- The flue must have a minimum 1°; maximum 3° (1° = 17mm per 1000mm) fall back to the appliance to allow any condensate that may form in the flue system to drain via the condensate drain. Consideration must also be given to the fact that there is the possibility of a small amount of condensate dripping from the terminal.
- Ensure that the entire flue system is adequately supported, use at least one bracket for each extension.
- The entire flue system must be adequately insulated to maintain heat within the flue system thereby reducing the possibility of condensate production.
- As the exhaust outlet pipe can reach very high temperatures it must be protected to prevent persons touching the hot surface.
- The condensate drain pipe must be connected in accordance with building regulations.

Reduction for bends

Bend	Reduction in maximum flue length for each bend
45° bend	1.0 metre
90° bend	1.0 metre

Twin flue accessories

Part No.	Description	Length
0225805	Horizontal flue terminal	1.0 metre
0225810	Vertical flue terminal	1.0 metre
359	Twin adapter kit	N/A
531	Pitched roof flashing plate	N/A
532	Flat roof flashing plate	N/A
0225815	Condensate drain kit	N/A
0225820	0.25m extension (pair)	250mm
0225825	0.5m extension (pair)	500mm
0225830	1.0m extension (pair)	1000mm
0225835	2.0m extension (pair)	2000mm
0225840	45° bend (pair)	N/A
0225845	90° bend (pair)	N/A
0225850	Twin bracket (5)	N/A
0225855	Single bracket (5)	N/A

MOUNTING THE BOILER

The fixing holes for the wall-mounting bracket should now be drilled and plugged, an appropriate type and quantity of fixing should be used to ensure that the bracket is mounted securely. Once the bracket has been secured to the wall, mount the appliance onto the bracket.

4.5.3.1 INSTALLATION OF TWIN ADAPTOR KIT (fig. 10 & 11)

- Insert the exhaust connection manifold (A) onto the appliance flue outlet.
- Remove the blanking plate and - using the same screws - install the air inlet plate (B).
- Using the hole in the exhaust connection manifold as a guide, drill a 3mm hole in the appliance flue spigot and secure the exhaust manifold connection to the flue spigot using the screw provided (C).
- Using the two holes in the air inlet plate as a guide, drill a 3mm hole in each and secure the air inlet pipe/bend using the screws provided.
- The twin flue pipes extensions and accessories can now be installed by pushing together (the plain end of each extension or bend should be pushed approximately 50mm into the female socket of the previous piece).

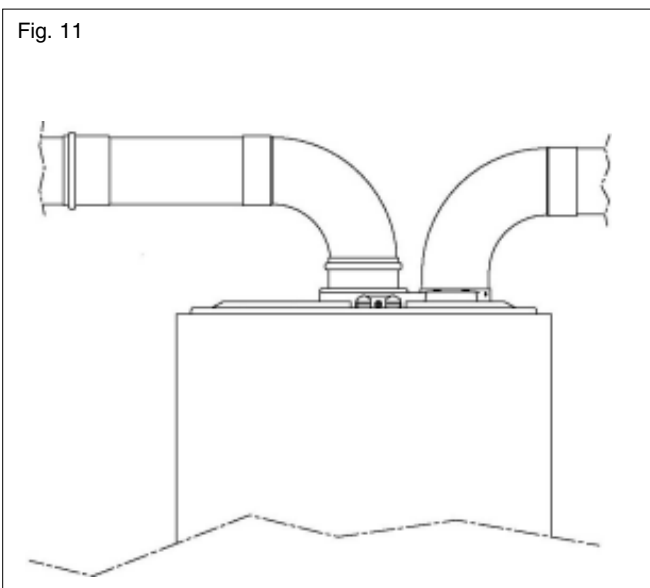
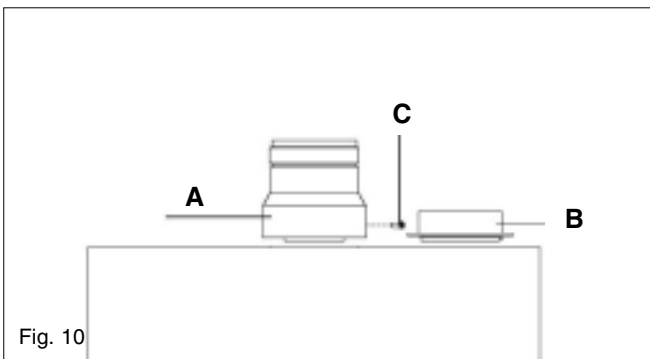

4.5.3.2 HORIZONTAL TERMINATION (see fig. 12)

The twin flue system must be converted to the dedicated concentric flue kit for termination.

- The horizontal terminal is supplied with a built-in converter box and cannot be shortened.
- A 130mm hole is required for the passage of the concentric terminal through the wall.
- The air inlet pipe must always be level with or below, that of the exhaust pipe.

Depending on site conditions it may be preferable to install the terminal assembly prior to fitting the twin flue pipes.

Mark and drill a 130mm hole for the passage of the horizontal flue terminal, ensuring that there is a 1° fall back to the boiler (17mm per 1000mm). Insert the terminal assembly into the flue hole.

Push-fit the twin flue pipes onto the concentric to twin converter box ensuring that the exhaust pipe connects to the exhaust connection on the concentric to twin converter.

If necessary cut the plain ends (male) of the twin flue pipes to allow connection to the concentric to twin converter.

NOTE

Before cutting twin flue pipes ensure allowances have been made for connection onto the previous piece and onto the concentric to twin converter. The last twin flue pipes must be pushed 50mm onto the male spigots of the concentric to twin converter.

NOTE

You must ensure that the entire flue system is properly supported and connected.

Seal the flue terminal assembly to the wall using cement or a suitable alternative that will provide satisfactory weatherproofing. The interior and exterior trim can now be fitted.

4.5.3.3 VERTICAL TERMINATION (see fig. 13)

The twin flue system must be converted to the dedicated concentric flue kit for termination.

- The vertical terminal is supplied with a built-in converter box and cannot be shortened.
- A 130mm hole is required for the passage of the concentric terminal through the ceiling and/or roof.

Depending on site conditions it may be preferable to install the terminal assembly prior to fitting the twin flue pipes.

Fit the appropriate flashing plate to the roof and insert the vertical flue terminal through the flash-

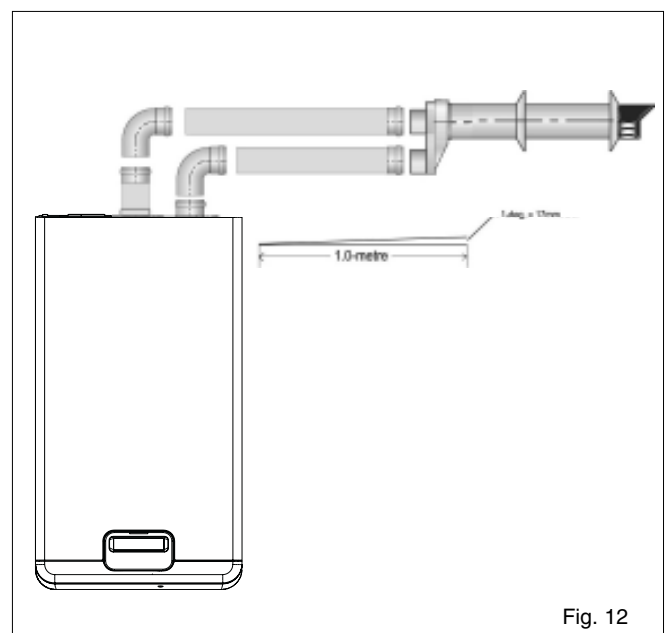

ing plate from the outside, ensuring that the collar on the flue terminal fits over the flashing.

Push-fit the twin flue pipes onto the concentric to twin converter ensuring that the exhaust pipe connects to the exhaust connection on the concentric to twin converter.

If necessary cut the plain ends (male) of the twin flue pipes to allow connection to the concentric to twin converter.

NOTE

- Before cutting twin flue pipes ensure allowances have been made for connection onto the previous piece and onto the concentric to twin converter. The last twin flue pipes must be pushed 50mm onto the male spigots of the concentric to twin converter.
- You must ensure that the entire flue system is properly supported and connected.
- Ensure that any horizontal sections of pipe have at least a 1° fall towards the appliance (17mm per-metre).

4.6 CONNECTING THE GAS AND WATER IMPORTANT - REAR SPACER KIT

If you intend to run the pipework vertically behind the appliance, it will be necessary to use the rear spacer kit (part code 435). It will also be necessary to adjust the pitch of the fixing jig to compensate for the increase in the depth of the appliance. The appliance is supplied with a fixing jig that includes service valves (fig. 14). The service valves are of the compression type. The accessories pack contains sealing washers etc, for use with the service valves.

When connecting pipe work to the valves, tighten the compression end first then insert the sealing washers before tightening the valve to the appliance.

NOTE

It will be necessary to hold the valve with one spanner whilst tightening with another.

4.6.1 GAS (fig. 6 & 14)

The appliance is supplied with a 15mm service valve, connect a 15mm pipe to the inlet of the valve and tighten both nuts.

NOTE

It will be necessary to calculate the diameter of the gas supply pipe to ensure the appliance has an adequate supply of gas.

4.6.2 FLOW & RETURN (fig. 6 & 14)

The appliance is supplied with 22mm service valves for the flow and return connections, connect a 22mm pipe to the inlet of each valve and tighten both nuts.

NOTE

Depending on system requirements, it may necessary to increase the size of the flow & return pipe work immediately after the service valve connections.

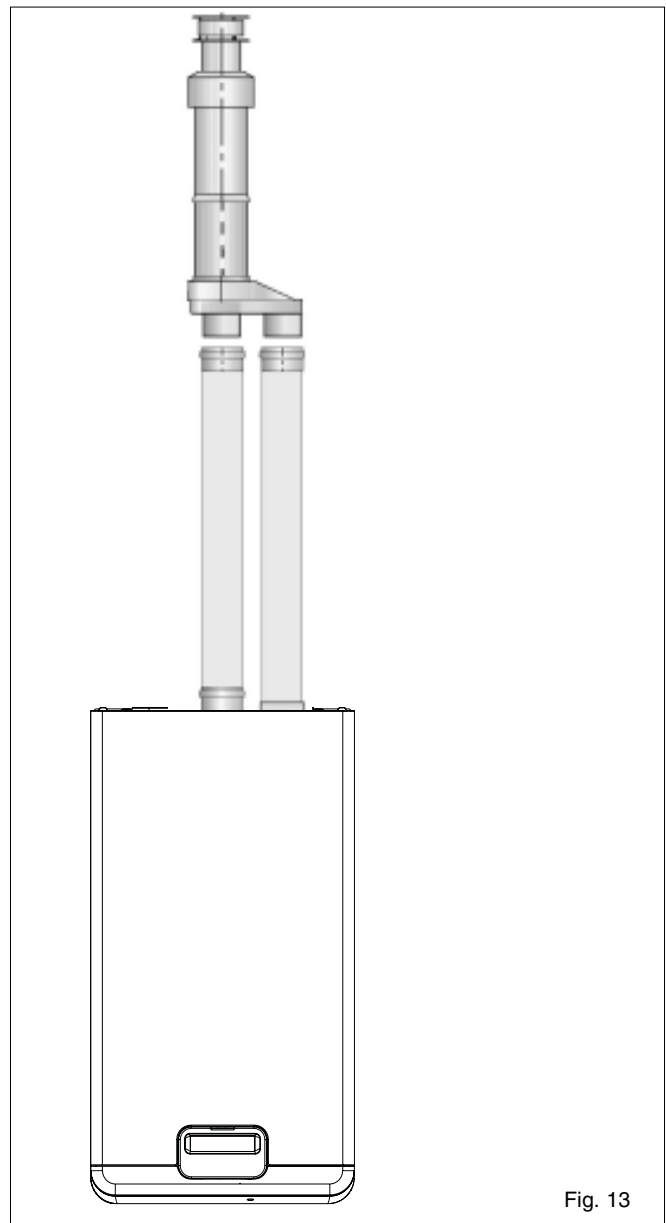

Fig. 13

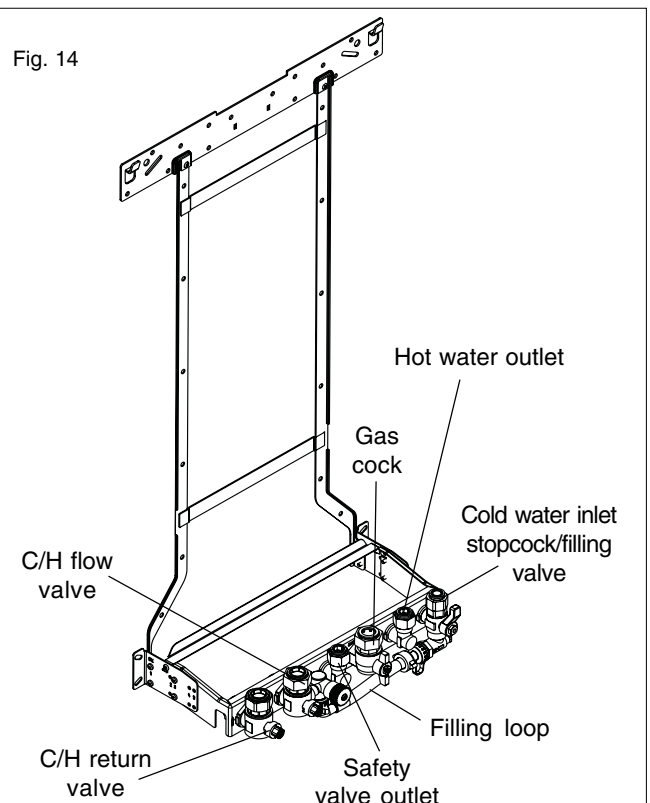

Fig. 14

4.6.3 COLD WATER INLET (fig. 6 & 14)

The appliance is supplied with a 15mm combined stopcock and double check-valve, connect a 15mm pipe to the inlet of the stopcock and tighten both nuts.

4.6.4 HOT WATER OUTLET (fig. 6 & 14)

The appliance is supplied with a 15mm outlet connection, connect a 15mm pipe to the outlet connection and tighten both nuts.

4.6.5 SAFETY VALVE (fig. 6 & 14)

Connect a discharge pipe to the fixing jig connection and tighten. The discharge pipe must have a continuous fall away from the appliance to outside and allow any water to drain away thereby eliminating the possibility of freezing. The discharge pipe must terminate in a position where any water – possibly boiling – discharges safely without causing damage or injury, but is still visible.

4.6.6 CONDENSE PIPE

During normal operation the boiler produces condense which is collected in a trap located in the lower part of the boiler. A flexible pipe (condense outlet pipe) is connected to the outlet of the trap. The flexible pipe must be connected to a plastic waste pipe only. The plastic waste pipe must have a minimum of a 3° fall towards the drain. Any external run of pipe should be insulated to prevent the risk of freezing.

CONNECTING THE CONDENSATE OUTLET

Gently pull the condense outlet pipe down from its location inside the boiler until it protrudes from the underside of the boiler. Connect a suitable plastic (not copper) pipe (no less than 20mm diameter) to the outlet pipe and ensure it discharges in accordance with building regulations or other rules in force.

4.7 ELECTRICAL CONNECTIONS

The electrical supply must be as specified in section 3/3A. A qualified electrician should connect the electrical supply to the appliance. If controls – external to the appliance – are required, a competent person must undertake the design of any external electrical circuits, please refer to section 8 for detailed instructions.

ANY EXTERNAL CONTROL OR WIRING MUST BE SERVED FROM THE SAME ISOLATOR AS THAT OF THE APPLIANCE.

The supply cable from the isolator to the appliance must be 3-core flexible sized 0.75mm to BS 6500 or equivalent. Wiring to the appliance must be rated for operation in contact with surfaces up to 90 °C.

4.7.1 CASING REMOVAL (fig. 15)

Remove transit screws **C** once the boiler has been mounted on the wall.

To gain internal access to the appliance you must first remove the casing, proceed as outlined below:

- locate and remove the screw **A**;
- remove the cover from the underside of the appliance casing;
- locate and remove the 2 screws **B** located at the Left & Right of the underside of the casing;
- lift the casing upward to disengage it from the top locating hooks and then remove;
- store the casing and screws safely until required. Re-fit in the reverse order.

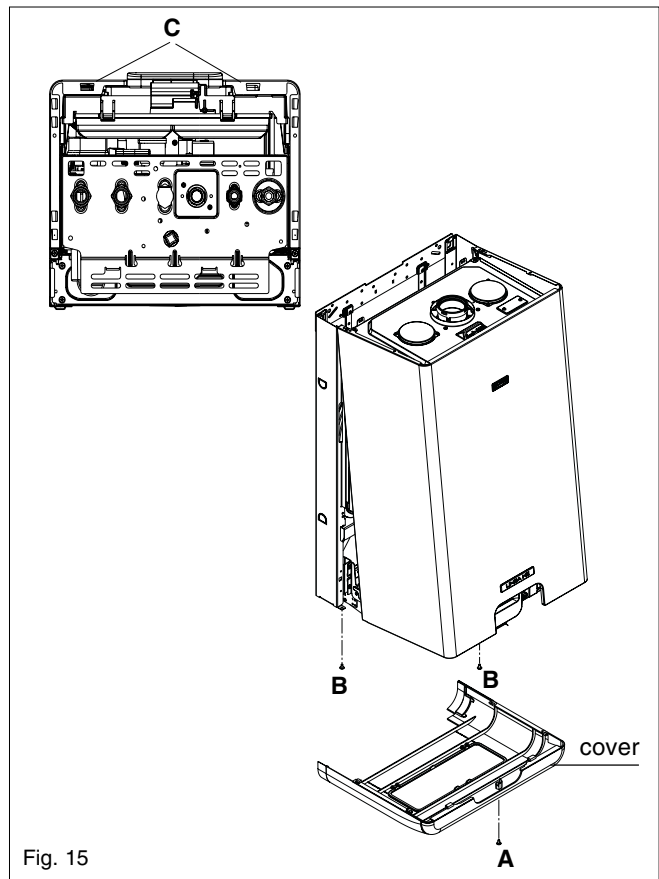

Fig. 15

4.7.2 APPLIANCE TERMINAL BLOCK

The appliance terminal block is located on the rear of the control fascia. Remove the casing as described in 4.7.1. Lift the control fascia upward and lower it. Locate the terminal block covers (see fig. 16).

NOTE

The appliance comes with a factory fitted link to allow basic operation of the boiler via the mode selector switch. If it is anticipated that external controls will be required please refer to the wiring diagrams in section 8 for more detailed information.

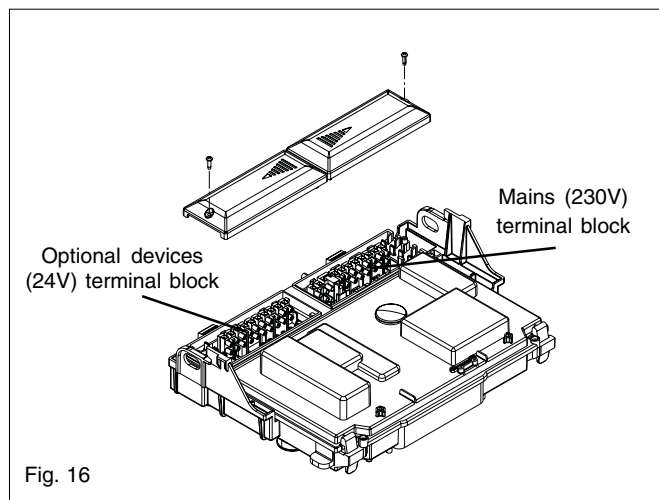

Fig. 16

4.7.3 CONNECTING THE MAINS (230V) INPUT (see fig. 17)

Locate and remove the screw securing the right terminal block cover (230V). Pass the cable through the cable anchorage point.

Connect the supply cable wires (LIVE, and NEUTRAL) to their corresponding terminals on the appliance terminal block. Connect the EARTH wire to the EARTH block (see fig. 17) ensuring that it's left slightly longer than the others, this will prevent strain on the EARTH wire should the cable become taut.

Do not remove the link wire unless additional external controls are to be fitted (see section 8). The securing screw on the cable anchorage point should now be tightened. This must be done before the control fascia is re-fitted in the upright position. The appliance casing, screws, and lower cover can now be re-fitted.

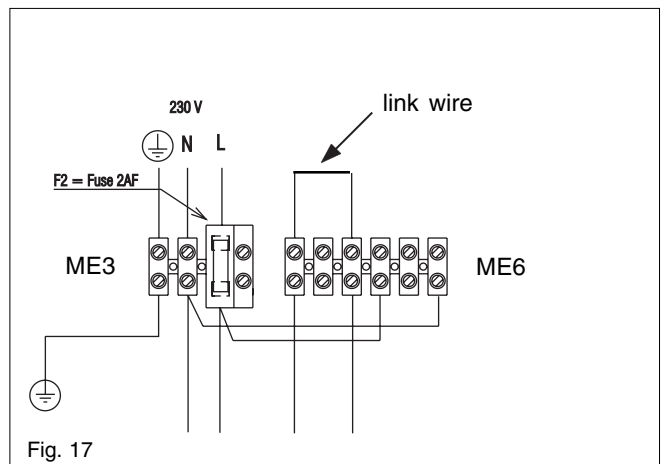

Fig. 17

SECTION 5 COMMISSIONING

5.1 GAS SUPPLY INSTALLATION

Inspect the entire installation including the gas meter, test for soundness and purge. Refer to BS 6891 for specific instruction.

5.2 THE HEATING SYSTEM

The appliance contains components that may become damaged or rendered inoperable by oils and/or debris that are residual from the installation of the system, consequently it is essential that the system be flushed in accordance with the following instructions.

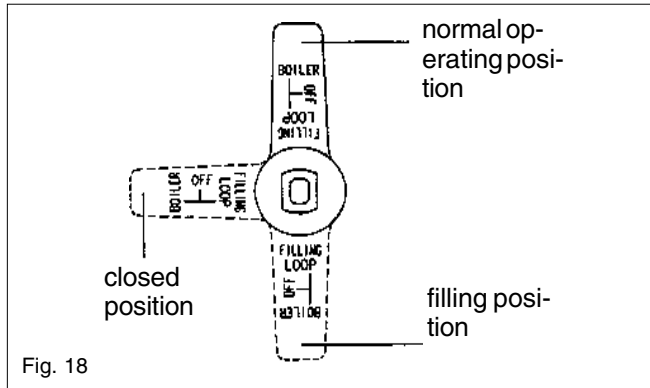

Fig. 18

5.3 INITIAL FILLING OF THE SYSTEM

Ensure both flow and return service valves are open, remove appliance casing as described in 4.7.1, identify the automatic air release valves (AAV) and loosen the dust cap/s by turning the cap anti-clockwise one full turn.

IMPORTANT, THERE ARE NO MANUAL AIR RELEASE VALVES LOCATED ON THE APPLIANCE. Ensure all manual air release valves located on the heating system are closed.

Connect the filling loop as shown in fig. 6B, slowly proceed to fill the system by firstly opening the inlet valve connected to the flow valve, and then turning the lever on the combined stopcock and check valve, to the filling position (see fig. 18). As water enters the system the pressure gauge will begin to rise. Once the gauge has reached 1 BAR close both valves and begin venting all manual air release valves, starting at the lowest first. It may be necessary to go back and top-up the pressure until the entire system has been filled. Inspect the system for water soundness, rectifying any leaks.

5.4 INITIAL FLUSHING OF THE SYSTEM

The whole of the heating system must be flushed both cold and hot as detailed in 5.8. Open all radiator or heating valves and the appliance flow & return service valve. Drain the boiler and system from the lowest points. Open the drain valve full bore to remove any installation debris from the boiler prior to lighting. Refill the boiler and heating system as described in 5.3.

5.5 FILLING THE HOT WATER SYSTEM

Close all hot water outlets, turn appliance stopcock to the normal operating position (fig. 18), slowly open each outlet until air has been expelled and clear pipe water is discharged.

Check pipe-work etc. for water soundness.

5.6 PRE-OPERATION CHECKS

Before attempting the initial lighting of the appliance, the following checks must be carried out:

- ensure all gas service valves from the meter to the appliance are open and the supply pipe has been properly purged;
- ensure the proper electrical checks have been carried out, (see 7.8) particularly continuity, polarity, and resistance to earth;
- ensure the 3 AMP fuse – supplied with the appliance – has been fitted;
- ensure the system has been filled, vented, and the pressure set to 1 BAR;
- ensure the flue system has been fitted properly and in accordance with the instructions;
- ensure all appliance service valves are open.

5.7 INITIAL LIGHTING

Ensure the electrical supply to the appliance is switched on. Press the ON/OFF switch to switch the appliance ON (indicated by active display), ensure any external controls are switched to an 'ON' position and are calling for heat.

Press the function button and select *Wintermode*, the appliance will now operate in the *Wintermode* as described in 1.2. Should the appliance fail to ignite, refer to 5.6 and/or section 7 (mode of operation, parameter setting, & faultfinding).

5.7.1 CHECKING GAS PRESSURE AND COMBUSTION ANALYSIS

The appliance is factory set and requires no additional adjustment once installed. However to satisfy the requirements of GSIUR 26/9 (I.S. 813 ROI), it will be necessary to gas rate the appliance using the gas meter that serves the appliance. If the installation does not include a gas meter (for example LPG) and there are no means by which to calculate the gas rate, then a combustion analysis test must be carried out in accordance with BS 7967 (UK) to ensure the appliance is left working safely and correctly. Additionally, if the gas valve has been adjusted, replaced, or the appliance has been converted for use with another gas type, then it becomes necessary to carry out a combustion analysis/check to ensure that correct combustion is occurring. If there are no means to gas rate the appliance and/or carry out a combustion analysis check, then it will not be possible to complete the commissioning procedure. Details on how to carry out the combustion analysis can be found in section 7.

IMPORTANT

It's imperative that a sufficient dynamic – gas – pressure is maintained at all times. Should the dynamic gas pressure fall below an acceptable level, the appliance may malfunction or sustain damage

5.8 FINAL FLUSHING OF THE HEATING SYSTEM

The system shall be flushed in accordance with BS 7593. Should a cleanser be used, it must be suitable for Copper and Aluminium heat exchang-

ers. It shall be from a reputable manufacturer and shall be administered in strict accordance with the manufacturers' instructions and the DWTA code of practice.

5.8.1 INHIBITORS

See Section 3 "General Requirements".

5.9 SETTING THE BOILER OPERATING TEMPERATURE

The flow outlet temperature can be adjusted between 39 °C - 80 °C via the Heating thermostat knob (see fig.1).

5.9.1 SETTING THE DOMESTIC HOT WATER TEMPERATURE

The DHW outlet temperature can be adjusted between 35 °C - 60 °C via the Hot Water thermostat knob (see fig.1).

5.9.2 INFORMATION MODE

The appliance keypad can be used to display certain information on the working status of the boiler. Push the Info button (i) to enter the info menu (fig. 18). The following information are shown pushing subsequently the ⏏ button:

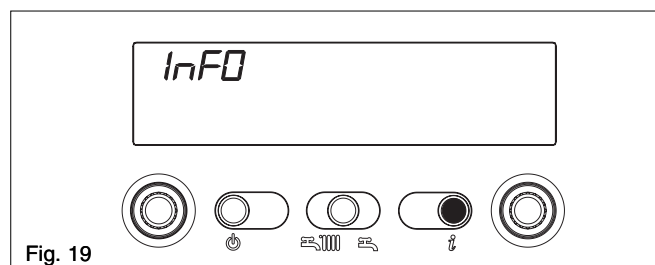

Fig. 19

- Info 1** outside temperature (only if outside sensor connected) (fig. 20)
- Info 2** water pressure (fig. 21)
- Info 3** CH temperature set (fig. 22)
- Info 4** DHW temperature set (fig. 23).

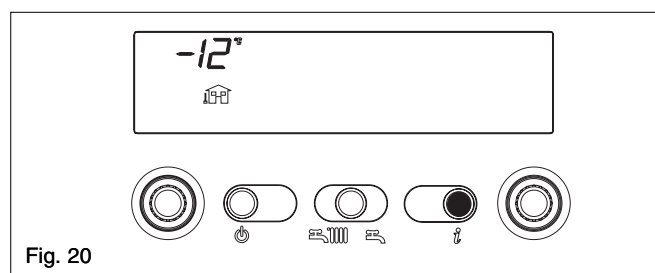

Fig. 20

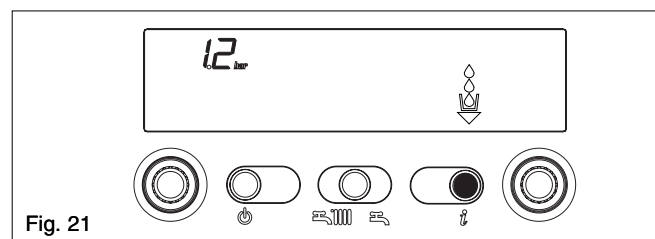

Fig. 21

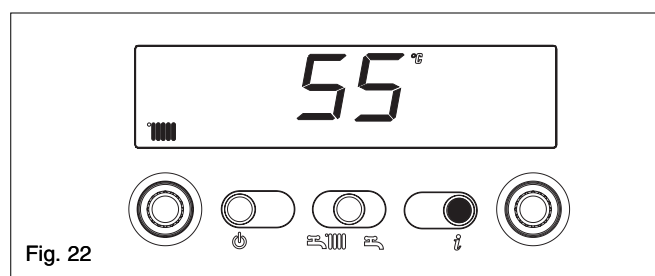

Fig. 22

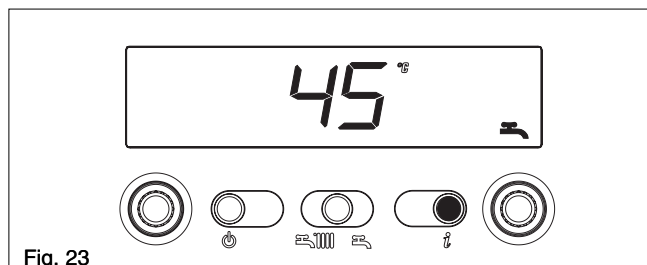

Fig. 23

5.9.3 INFORMATION MODE SERVICE

Push and hold for 10 seconds the Info button (i) to enter the info menu service (**INF2 is shown on the display**). The following information are shown pushing subsequently the ⏏ button:

Step number	Information displayed
01	Temperature at flow sensor °C
02	Temperature at return sensor °C
03	Temperature at hot water outlet sensor °C
04	Unused
05	Unused
06	Unused
07	Unused
FAN	Fan speed RPM/100
09	Unused
10	Unused

5.9.4 ADJUSTING APPLIANCE PARAMETERS

The appliance is delivered with pre-set parameters. Some parameters can be changed or adjusted if required. For further details, please refer to section 7.

5.10 SETTING THE SYSTEM DESIGN PRESSURE

The design pressure should be a minimum of 0.5 BAR and a maximum of 1.5 BAR. The actual reading should ideally be 1 BAR plus the equivalent height in metres (0.1 BAR = 1 metre) to the highest point in the system above the base of the appliance (up to the maximum of 1.5 BAR total).

N.B. The safety valve is set to lift at 3 BAR/30 metres/45 psig.

To lower the system pressure to the required value, drain off some water from the appliance drain valve until the required figure registers on the pressure gauge (see fig. 1).

5.11 REGULATING THE HOT WATER

The appliance is fitted with a flow rate restrictor that limits the maximum flow rate that can be drawn through the appliance.

The restrictor eliminates the need to manually adjust the DHW flow rate. However if it is felt necessary to further increase or decrease the available flow rate, spare restrictors are included in the accessory pack.

The spare flow rate restrictors can be fitted to either increase or decrease the maximum flow rate. The tables overleaf denote the size of restrictor fitted and the spare restrictors supplied in the accessory pack. Each restrictor is colour-coded to enable identification.

5.11.1 CHANGING THE FLOW RESTRICTOR

Refer to 6.17 for detailed instruction on changing the flow restrictor.

Linea 28HE

9-litre (orange)	10-litre (blue)	11-litre (beige)
Fitted	Spare	Spare

Linea 32HE

11-litre (orange)	12-litre (blue)	13-litre (beige)
Spare	Fitted	Spare

Linea 36HE

11-litre (beige)	12-litre (red)	13-litre (olive)
Spare	Fitted	Spare

5.11.2 REGULATING THE CENTRAL HEATING SYSTEM

Fully open all radiator and circuit valves and run the appliance for both heating and hot water until heated water is circulating. If conditions are warm remove any thermostatic heads. Adjust radiator return valves and any branch circuit return valves until the individual return temperatures are correct and are approximately equal.

5.12 FINAL CHECKS

- ENSURE ALL TEST NIPPLES ON THE APPLIANCE GAS VALVE ARE TIGHT AND CHECKED FOR SOUNDNESS.
- ENSURE THE APPLIANCE FLUE SYSTEM IS FITTED CORRECTLY AND IS PROPERLY SECURED.
- ENSURE ALL PIPE WORK IS RE-CHECKED FOR SOUNDNESS.
- RE-FIT APPLIANCE CASING.
- COMPLETE BENCHMARK CHECKLIST.

FOR UK ONLY

Complete details of the boiler, controls, installation and commissioning in the Benchmark checklist at the back of this book. It is important that the Benchmark checklist is correctly completed and handed to the user. Failure to install and commission the appliance to the manufacturers instructions may invalidate the warranty.

5.13 INSTRUCTING THE USER

Hand over all documentation supplied with this appliance – including these instructions – and explain the importance of keeping them in a safe place.

Explain to the user how to isolate the appliance from the gas, water and electricity supplies, and the locations of all drain points.

Show the user how to operate the appliance and any associated controls correctly.

Show the user the location of the filling valve and how to top-up the system pressure correctly and show the location of all manual air release points.

Explain to the user how to turn off the appliance for both long and short periods and advise on the necessary precautions to prevent frost damage. Explain to the user that for continued safe and efficient operation, the appliance must be serviced annually by a competent person.

IMPORTANT

To validate the appliance warranty, it's necessary to register the appliance details with us. The warranty can be registered in several ways:

- by completing the warranty registration card and posting to us using the pre-paid envelope supplied
- online at: vokera.co.uk
- for UK residents by calling: 0870 607 0281
- for ROI residents by calling: 1850 221121.

SECTION 6 SERVICING INSTRUCTIONS

6.1 GENERAL

To ensure the continued safe and efficient operation of the appliance, it is recommended that it is checked and serviced at regular intervals.

To ensure correct and safe operation of the appliance, it is essential that any worn or failed component be replaced only with a **genuine Vokera spare part**. It should be remembered that although certain generic components may look similar, they will be specific to an individual appliance or product range. Use of non-genuine Vokera spare parts could invalidate your warranty and may pose a potential safety hazard. The frequency of servicing will depend upon the particular installation conditions, but in general, once per year should be sufficient. It is the law that any servicing work is carried out by competent person such as a Vokera engineer, an approved service agent, British Gas, CORGI registered personnel or other suitably qualified personnel.

The following instructions apply to the appliance and its controls, but it should be remembered that the central heating and the domestic hot water systems would also require attention from time to time.

6.2 ROUTINE ANNUAL SERVICING

- Check the operation of the appliance and ensure it functions as described in section 7.
- Compare the performance of the appliance with its design specification. The cause of any noticeable deterioration should be identified and rectified without delay.
- Thoroughly inspect the appliance for signs of damage or deterioration especially the flue system and the electrical apparatus.
- Check and adjust – if necessary – all burner pressure settings (see 7.4).
- Check and adjust – if necessary – the system design pressure (see 5.10).
- Carry out an analysis of the flue gases (see 7.5), and visually check the condition of the entire flue assembly.
- Compare the results with the appliance design specification. Any deterioration in performance must be identified and rectified without delay.
- Check that the burner and main heat exchanger are clean and free from any debris or obstruction.
- Check and clean – if necessary – the condensate trap to ensure correct operation.

6.3 REPLACEMENT OF COMPONENTS

Although it is anticipated that this appliance will give years of reliable, trouble free service, the life span of components will be determined by factors such as operating conditions and usage. Should the appliance develop a fault, the fault finding section will assist in determining which component is malfunctioning.

6.4 COMPONENT REMOVAL PROCEDURE

To remove a component, access to the interior of the appliance is essential. Isolate the appliance from the electrical supply and remove the fuse. And when necessary, close all service valves on the appliance, remove the appliance casing as described in section 4.7.1 and drain the water content from the appliance via the drain valve.

Ensure some water absorbent cloths are available to catch any residual water that may drip from the appliance or removed component. Undertake a complete commissioning check as detailed in section 5, after replacing any component. **ALWAYS TEST FOR GAS SOUNDNESS IF ANY GAS CARRYING COMPONENTS HAVE BEEN REMOVED OR DISTURBED.**

6.4.1 AIR BOX FRONT COVER REMOVAL (fig. 24)

Locate the two clips and remove air box front cover. If necessary to remove the air box side cover, locate and remove the 4 screws.

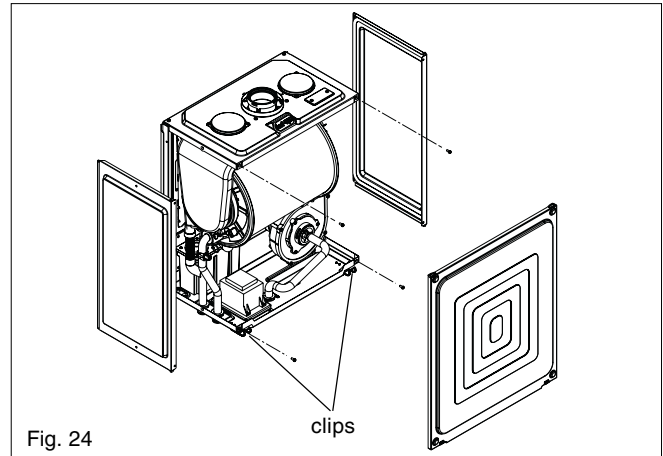

Fig. 24

6.5 PUMP ASSEMBLY (fig. 25)

Carry out component removal procedure as described in 6.4.

Locate and remove the 2 securing screws (A) at the rear of the pump assembly. Disconnect the flow pipe (B) from the combustion chamber connection, slacken the pipe at the hydraulic assembly and swing/rotate clear of the pump assembly. Disconnect and remove the pump outlet pipe (C) from the pump assembly/combustion chamber connection. Remove the expansion pipe locking pin from the top of the pump assembly and withdraw the flexible pipe (D). Disconnect the electrical wiring from the pump's electrical connection point (E). Remove locking pin (F) from pump base and lift pump assembly clear of the hydraulic manifold.

The pump assembly can now be removed from the appliance. Replace carefully in the reverse order.

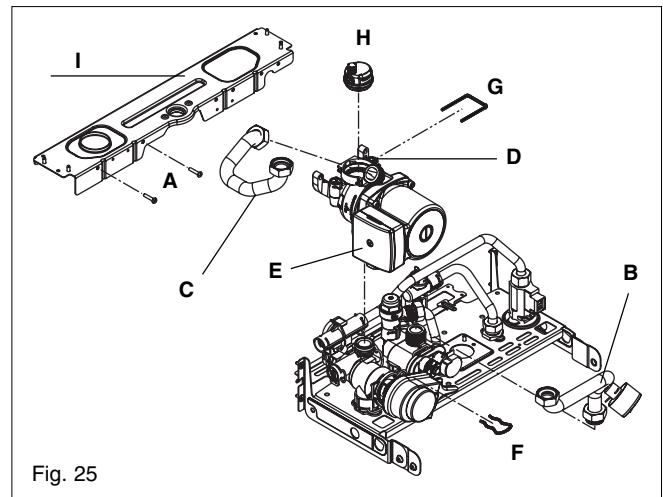

Fig. 25

6.6 SAFETY VALVE (fig. 26)

Carry out component removal procedure as described in 6.4. Disconnect the outlet pipe (A) from the safety valve, remove safety valve locking pin (B) from the hydraulic manifold. Replace in the reverse order.

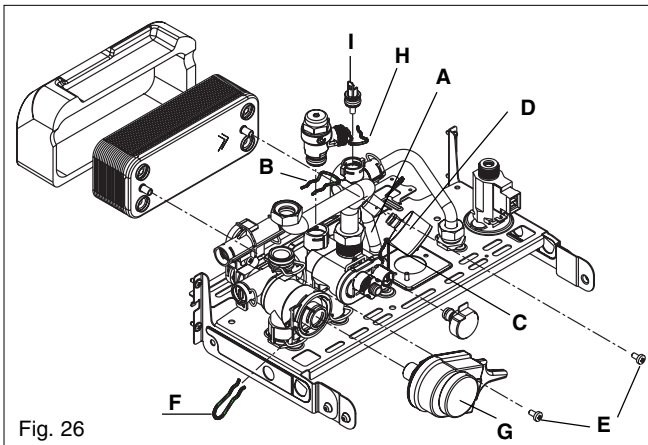

Fig. 26

6.7 BOTTOM AUTOMATIC AIR RELEASE VALVES (fig. 25)

Carry out component removal procedure as described in 6.4.

Remove the expansion pipe locking pin (D) from the pump assembly and remove the expansion pipe. Locate and remove the AAV locking pin (G) from the pump assembly and remove the AAV assembly (H). Replace in the reverse order.

6.7.1 TOP AAV (fig. 27)

Carry out component removal procedure as described in 6.4.

Remove the drain pipe (A). Unscrew the top AAV. Replace in the reverse order. White Loctite is necessary to fix the AAV.

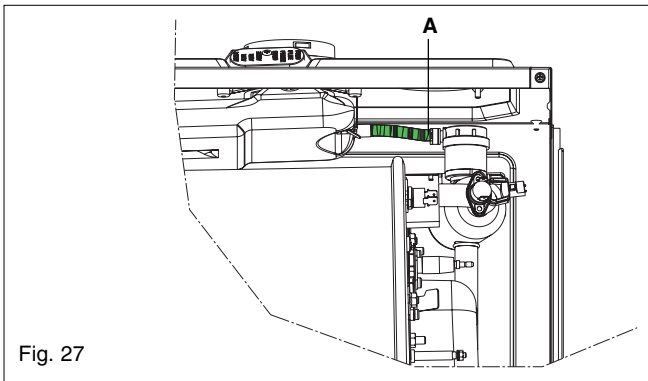

Fig. 27

6.8 WATER PRESSURE SENSOR/GAUGE (fig. 26)

Carry out component removal procedure as described in 6.4.

Locate and remove the locking pin (C) from the water pressure sensor/gauge assembly (D). Remove the wiring. Carefully withdraw the assembly. Replace in the reverse order.

6.9 PRIMARY THERMISTOR (fig. 1)

Carry out component removal procedure as described in 6.4.

Unclip and remove the air chamber front cover. Unclip the primary thermistor from the flow outlet pipe. Disconnect thermistor electrical plug. Replace in the reverse order.

6.10 RETURN THERMISTOR (fig. 1)

Carry out component removal procedure as described in 6.4.

Unclip and remove the air chamber front cover. Unclip the return thermistor from the return inlet pipe. Disconnect thermistor electrical plug. Replace in the reverse order.

6.11 PRINTED CIRCUIT BOARD (fig. 28)

Carry out component removal procedure as described in 6.4.

Lift the control fascia upward and rotate it. Locate and remove the screws (A) which secure the PCB cover, push the clips (B) and remove cover, after carefully taking note of all wiring connections, disconnect all wiring from the PCB, locate and remove the PCB securing screws, remove the required PCB. Replace in the reverse order.

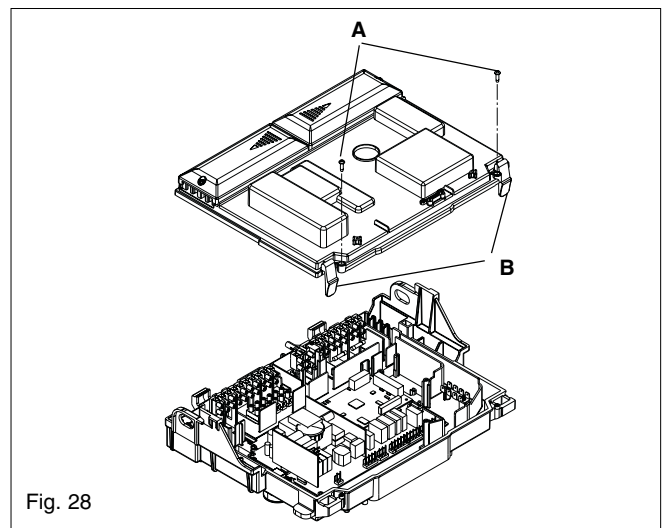

Fig. 28

6.12 GAS VALVE (fig. 14 & 29)

Carry out component removal procedure as described in 6.4.

The gas valve must be changed as complete unit. Disconnect the electrical plug and leads from the gas valve, loosen and unscrew gas valve inlet (A, fig. 14) and outlet (A, fig. 29) connections. **Please note**, the sealing washers (B) must be discarded and replaced with new sealing washers. Disconnect the compensation pipe (C). Locate and remove gas valve retaining screws (D) on the underside of the boiler if required, the gas valve can now be removed. Replace in the reverse order. Check and adjust burner pressure settings.

WARNING, A GAS SOUNDNESS CHECK MUST BE CARRIED OUT.

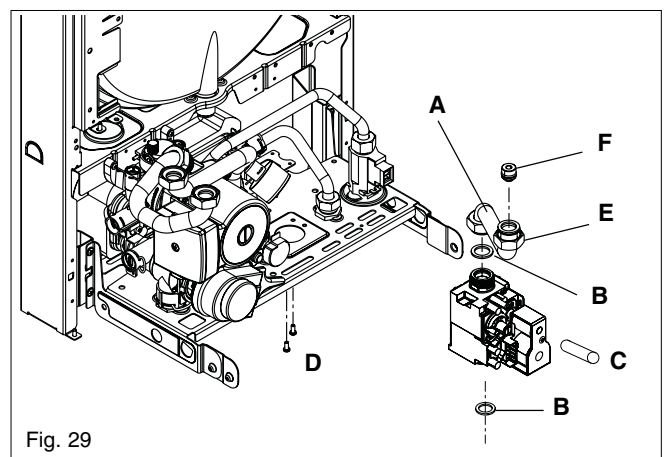

Fig. 29

6.12.1 INJECTOR (fig. 29)

Carry out component removal procedure as described in 6.4.

Unscrew and remove gas pipe connections (A & E). Locate and remove the injector (F) inside the pipe. Replace in the reverse order. Check and adjust burner pressure settings.

WARNING, A GAS SOUNDNESS CHECK MUST BE CARRIED OUT.

6.13 ELECTRODE & CONDENSE SENSOR (fig. 30)

Carry out component removal procedure as described in 6.4.

Unclip and remove the air chamber front and RH side covers. Disconnect the electrode lead and ancillary wiring from their respective connectors. Remove the 2 retaining screws (A) for electrode (B) and remove. Remove the retaining nut (C) for condense sensor (D) and remove.

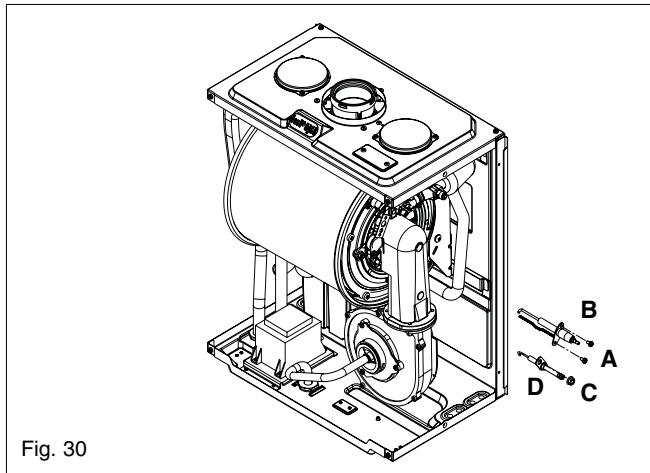

Fig. 30

6.14 FLUE FAN & MIXER (fig. 31)

Carry out component removal procedure as described in 6.4.

Unclip and remove the air chamber front and the RH side covers. Slacken the gas pipe (A) at the air box connection and swing/rotate of the fan assembly.

To remove the mixer (B) locate and remove the three screws (C). To remove the fan (D), disconnect the electrical connections attached to the fan, locate and remove the four screws (E).

Gently ease the fan from its location.

Replace in the reverse order. Ensure all seals are in good condition, taking care to ensure they are replaced correctly.

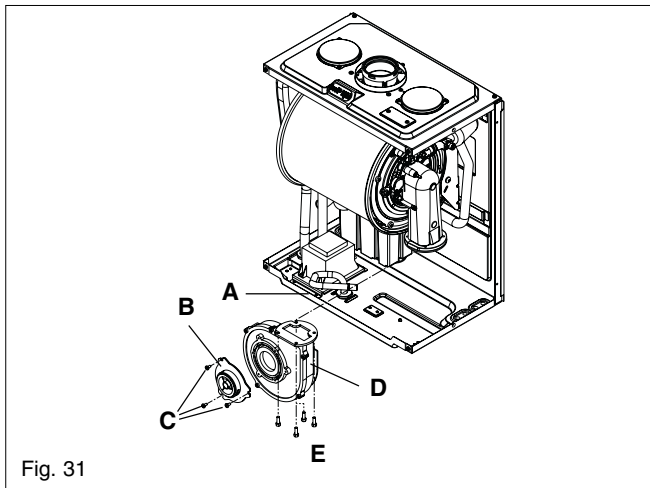

Fig. 31

6.15 BURNER (fig. 32)

Carry out component removal procedure as described in 6.4.

Unclip and remove the air chamber front and the RH side covers. Slacken the gas pipe (A) at the air box connection and swing/rotate of the fan assembly. Locate and remove the 3 internal nuts (B) which secure the fan assembly in position (C) to the heat exchanger (D). Gently ease the fan assembly out of its location. Once the assembly has been removed, the burner (E) can be withdrawn from the heat engine. Ensure the seal (F) is in good condition, taking care to ensure it is replaced correctly. Replace in the reverse order.

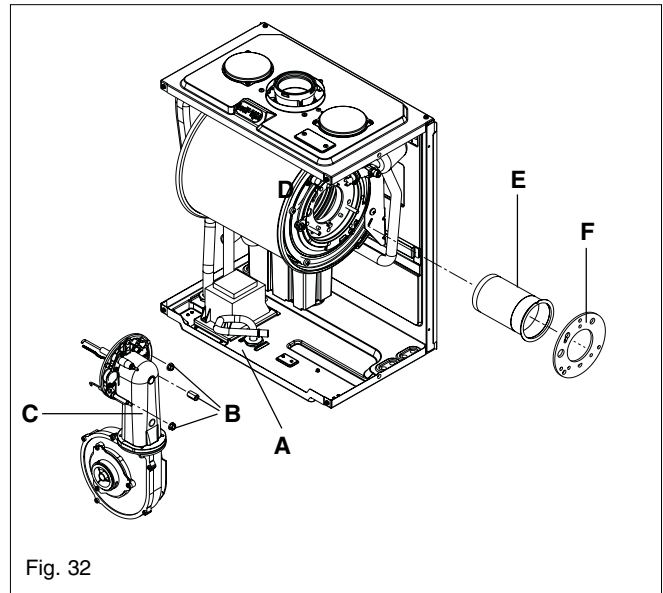

Fig. 32

6.16 MAIN HEAT EXCHANGER (fig. 33 & 34)

Carry out component removal procedure as described in 6.4.

Unclip and remove the three air chamber covers (front, LH, RH sides). Disconnect all the wiring connections.

Fig. 33: Slacken the gas pipe (A) at the air box connection and swing/rotate of the fan assembly. Disconnect the flow (B), return (C) and condense connections on the heat exchanger. Locate and remove the 4-screws that secure the heat exchanger to the combustion chamber (D). Move the heat exchanger to the right and disconnect it from the flue collector (E). The heat exchanger can now be lifted up and withdrawn from the appliance.

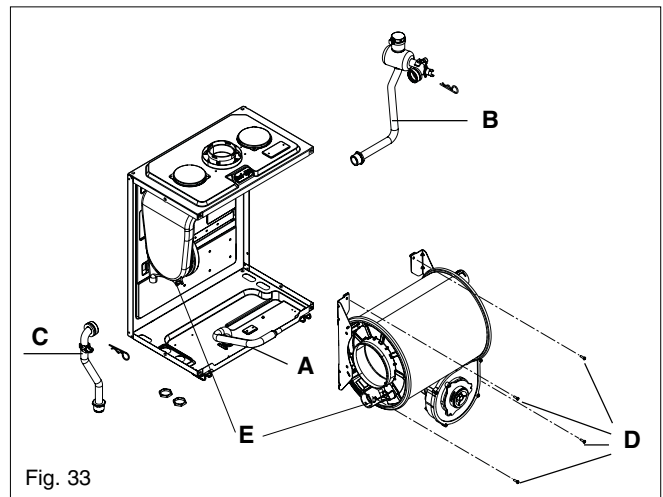

Fig. 33

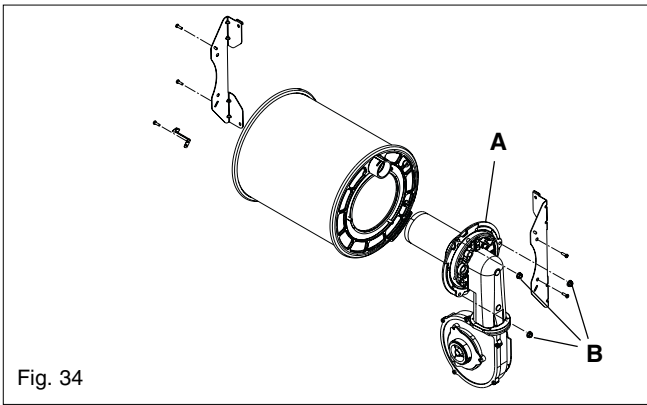

Fig. 34

6.17 FLOW RESTRICTOR (fig. 35)

Carry out the component removal procedure as described in 6.4.

Disconnect the cold water inlet pipe at the DHW flow switch (A). Using a small screwdriver, gently ease the flow restrictor (B) from its seating. Replace in the reverse order. Ensure all seals are in good condition, taking care to ensure they are replaced correctly.

6.18 DHW FLOW SWITCH (fig. 35)

Carry out component removal procedure as described in 6.4.

Remove the locking pin (C). Disconnect and remove the cold water inlet pipe from the DHW flow switch & DHW heat exchanger. Disconnect the wiring to the DHW flow switch. Loosen and unscrew the inlet connection (B, fig. 14). Unscrew the nut (D). Lift the DHW flow switch housing from its seating. If necessary remove the locking pin (E) from the DHW flow switch, taking care not to lose the float contained within the housing.

Replace in the reverse order ensuring that the housing is firmly inserted onto its seating. Ensure all seals are in good condition, taking care to ensure they are replaced correctly.

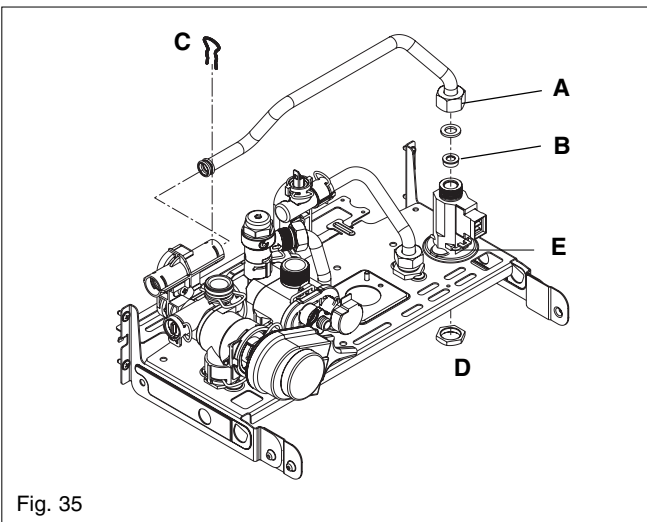

Fig. 35

6.19 DHW HEAT EXCHANGER (fig. 36)

Carry out component removal procedure as described in 6.4. Locate and remove the screws (E) that secure the heat exchanger to the DHW manifolds. Carefully remove the heat exchanger from its location taking care not to spill any residual water. Replace in the reverse order ensuring that the heat exchanger 'O' ring seals are correctly inserted into the DHW manifolds. Ensure all seals are in good condition, taking care to ensure they are replaced correctly.

6.20 VALVE ACTUATOR (fig. 36)

Carry out component removal procedure as described in 6.4.

Remove the locking pin (F) that secures the actuator (G) to the heating manifold. Disconnect the electrical plug from the actuator. Replace in the reverse order.

6.21 DIVERTOR VALVE ASSEMBLY (fig. 36)

Carry out component removal procedure as described in 6.4. Remove the valve actuator as described in 6.20. Locate and remove the locking pin (A) that secures the valve housing cover to the hydraulic manifold. Gently prise the valve assembly from the manifold. Replace in the reverse order ensuring that the seating assembly is inserted properly. Ensure all seals are in good condition, taking care to ensure they are replaced correctly.

6.22 DHW THERMISTOR (fig. 36)

Carry out component removal procedure as described in 6.4.

Locate and remove the thermistor locking pin (H). Gently ease the thermistor assembly (I) from the hydraulic manifold. Replace in the reverse order.

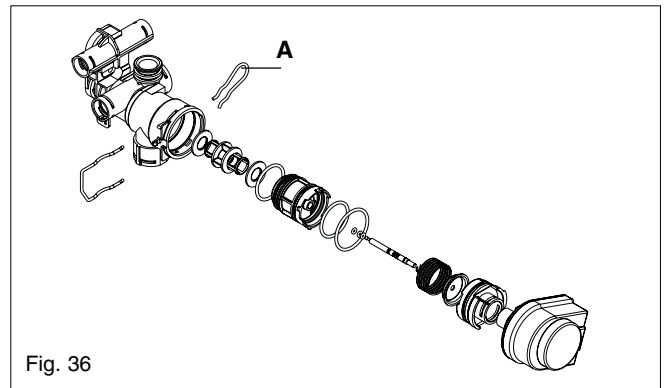

Fig. 36

6.23 AUTOMATIC BY-PASS & DHW NON-RETURN VALVE (fig. 37)

Carry out component removal procedure as described in 6.4.

Remove the locking pin (A) that secures the cover (B) to the hydraulic manifold. Using a hooked piece of wire, carefully withdraw the by-pass cartridge (C) and/or DHW non-return cartridge (D). Ensure all seals are in good condition, taking care to ensure they are replaced correctly. Replace in the reverse order ensuring the cartridge is facing the correct way.

6.24 EXPANSION VESSEL (fig. 1)

Should the removal and replacement of the expansion vessel be deemed impractical, an external expansion vessel may be fitted to the return pipe as close to the appliance as possible.

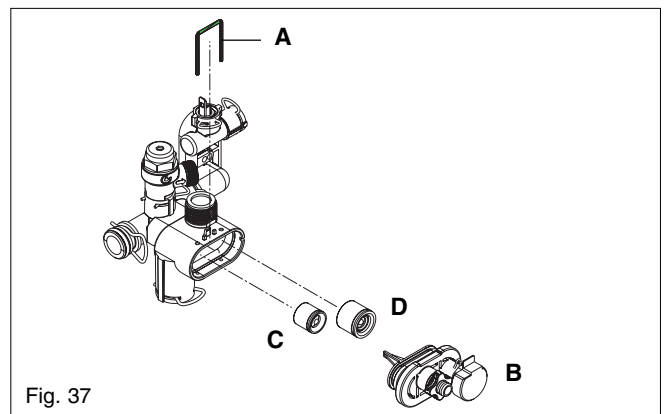

Fig. 37

6.24.1 EXPANSION VESSEL REMOVAL (with sufficient clearance above, fig. 25 & 38)

Carry out component removal procedure as described in 6.4.

Disconnect the flue from the appliance.

Disconnect the expansion vessel from the flexible expansion pipe.

Disconnect the flexible expansion pipe from the vessel. Unscrew the nut that secures the vessel to the frame (I, fig. 25). Locate and remove the 6 screws (A) that secure the vessel top holding plate (B), remove the plate.

The expansion vessel can now be removed.

Replace in the reverse order. Ensure all seals are in good condition, taking care to ensure they are replaced correctly.

6.25 FAN TRANSFORMER REMOVAL (fig. 39a)

Carry out component removal procedure as described in 6.4.

Unclip and remove the air chamber front and left side covers. Disconnect the fan transformer wiring. Locate and remove the 2 screws (D) that secure the fan transformer to the air box plate, cut the two cable ties previewed on heat-shrinkable insulators that protect the transformer connec-

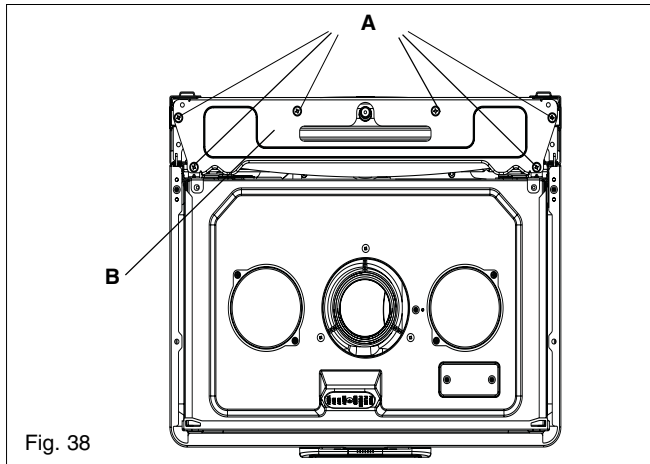

Fig. 38

tors. Unthread the heat-shrinkable insulators. Carefully remove the fan transformer. Replace in the reverse order.

ATTENTION The transformer connected, put the heat-shrinkable insulators and fix it through two new cable ties. The heat-shrinkable insulators assure the correct protection from liquid penetration of transformer connector.

6.26 CONDENSE TRAP REMOVAL (fig. 39b)

Carry out component removal procedure as described in 6.4.

Disconnect the 2 upper rubbers condense pipe (A). Remove the pin (B) that secures the trap to the air box plate. Disconnect the lower rubber condense pipe (C) from the condense trap.

Carefully remove the condense trap. Replace in the reverse order.

6.27 FLUE COLLECTOR REMOVAL (fig. 40)

Carry out component removal procedure as described in 6.4.

Unclip and remove the air chamber front and left side covers. Locate and remove the screw (A) that secures the flue gas analysis test point cover (B). Gently pull down and to the left and ease the flue collector from its location.

Replace in the reverse order.

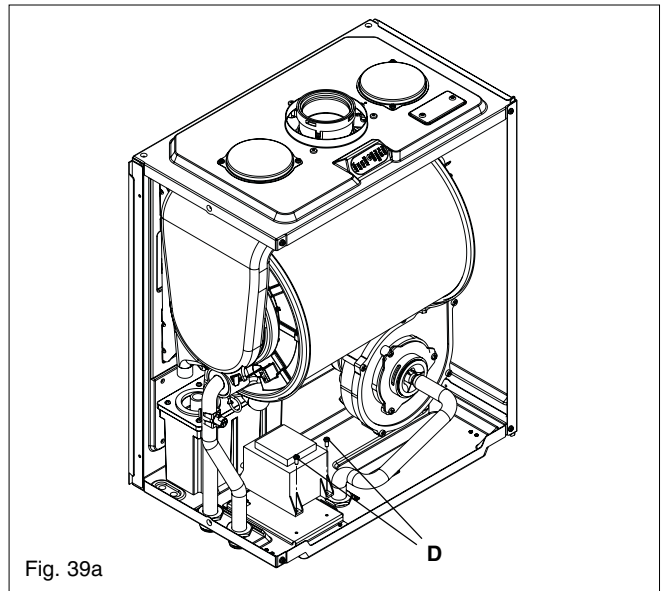

Fig. 39a

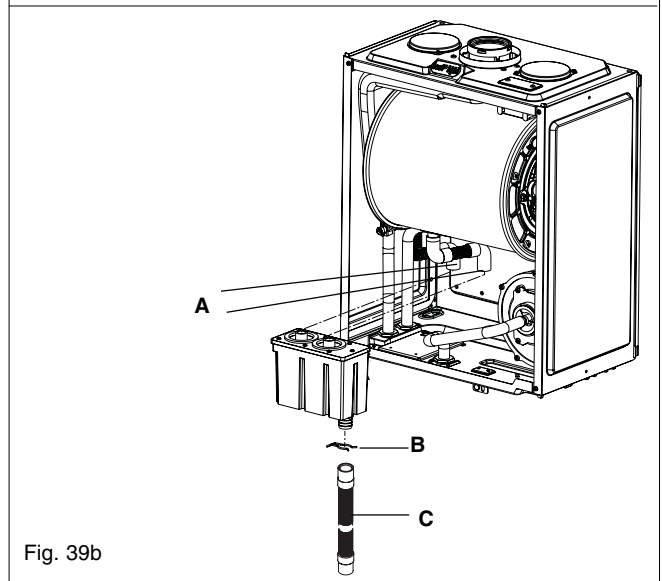

Fig. 39b

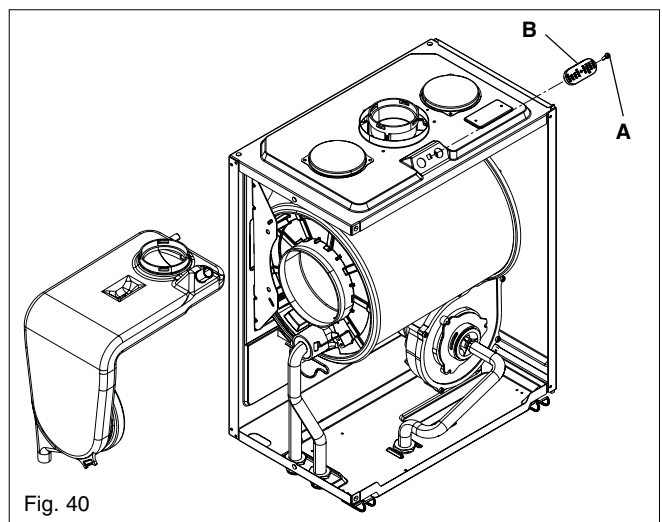

Fig. 40

7.1 CHECKING APPLIANCE OPERATION

When carrying out any repairs or servicing to the appliance, the relevant commissioning procedure must be undertaken to ensure the continued safe operation of the appliance. Particular attention should be made to ensure gas soundness, water soundness, and the electrical integrity of the appliance.

7.2 APPLIANCE MODES OF OPERATION NOTE

There must be sufficient system water pressure (min. 0.5 bar) to ensure the water pressure switch is activated. If there is insufficient system pressure the pump and fan will be prevented from operating and the low-pressure fault indicator will be displayed.

7.2.1 SELECTOR SWITCH IN THE OFF POSITION

When the selector switch is in the *STANDBY* position, no status indicators (see fig. 1A) are displayed.

Active functions:

- Frost-protection system
- Pump anti-block
- Valve actuator anti-block.

7.2.2 BOILER “ON” IN WINTER MODE

When the function switch is in the *Winter* position, the relevant status indicators (see fig. 1A) are displayed and the appliance is active for both heating and DHW requests.

Active functions:

- DHW pre-heat
- Booster function
- Frost-protection system
- Pump anti-block
- Valve actuator anti-block.

7.2.3 BOILER “ON” IN SPRING MODE

When the function switch is in the *Spring* position, the relevant status indicators (see fig. 1A) are displayed and the appliance is active for DHW requests.

Active functions:

- Frost-protection system
- Pump anti-block
- Valve actuator anti-block.

7.2.4 BOILER “ON” IN SUMMER MODE

When the function switch is in the *Summer* position, the relevant status indicators (see fig. 1A) are displayed and the appliance is active for DHW requests.

Active functions:

- TSC function
- Frost-protection system
- Pump anti-block
- Valve actuator anti-block.

7.2.5 BOILER “ON” IN AUTUMN MODE

When the function switch is in the *Autumn* position, the relevant status indicators (see fig. 1A)

are displayed and the appliance is active for both heating and DHW requests.

Active functions:

- SARA function
- TSC function
- Frost-protection system
- Pump anti-block
- Valve actuator anti-block

7.2.6 APPLIANCE FUNCTIONS

● **DHW pre-heat:** this function is only active when there are no requests for heating or hot water.

The pre-heat function has priority on CH request. When the secondary thermistor drops to 35°C, the pre-heat function is enabled, the appliance operates on minimum power until the secondary thermistor reaches 55°C. Thereafter the pump and fan will over-run.

● **SARA:** this function will automatically raise the outlet flow temperature when the heating temperature selector is in the 55-65°C range, if the appliance is unable to reach the room temperature set with room thermostat.

● **TSC:** the temperature stability control function (TSC) ensures that a steady temperature is maintained. This is achieved by the TSC function overriding the set DHW temperature – if necessary – during DHW operation/requests rather than switching the burner off when the set temperature is reached.

● **Booster function:** this function will automatically raise the flow outlet temperature if/when the appliance is unable to reach or maintain the desired flow outlet temperature (Heating).

● **Frost-protection:** this function is only active when there are no requests for heating or HW. Should the temperature of the primary thermistor drop below 7°C, the valve actuator will motor to the heating position. Should the temperature of the primary thermistor exceed 10°C during this period, the cycle will be aborted. If the temperature drops below 4°C, the boiler will operate on minimum power until the temperature of the primary thermistor reaches 30°C. Thereafter the pump & fan will over-run for 30-seconds.

● **Pump/actuator anti-block cycle:** when there has been no heating or HW request for 24-hours, the anti-block cycle is activated. The valve actuator will motor from the DHW position to the heating position for a period of 10-seconds and then motor back to the DHW position. Thereafter the pump will be activated for a period of 1-minute. If the selector switch is in the Heating & HW position, the fan will also be active for 1-minute.

7.2.7 HEATING MODE

With the selector switch in the autumn or winter position and any additional controls (time clock, room thermostat, etc.) calling for heat, the appliance will operate in the heating mode.

The valve actuator will motor to the heating position and the pump and fan will be activated via the

flow temperature sensor. When the fan is sensed to be operating correctly, the ignition sequence commences.

Ignition is sensed by the electronic circuitry to ensure flame stability at the burner. Once successful ignition has been achieved, the electronic circuitry allows 75% Of the full gas rate through the appliance. After 15 minutes (adjustable, see parameter 28, cap. 7.3.1) the gas rate is increased to maximum (100%).

The speed of the fan and therefore the output of the boiler is determined by the temperature of the water sensed by the flow temperature sensor, consequently a high temperature at the flow sensor results in a lower fan speed. As the water temperature increases, the temperature sensors – located on the flow pipe of the boiler – reduce the fan speed via the electronic circuitry. Depending on the load, either the water temperature will continue to rise until the set point is achieved or the water temperature will fall whereby fan speed will increase relative to the output required. When the boiler has reached the set point, the burner will switch off. The built-in anti-cycle device prevents the burner from re-lighting for an adjustable period of time (factory default is 5 minutes). When the temperature of the flow sensor falls below the set-point, the burner will re-light.

NOTE

If the spark/sensing electrode does not sense ignition the appliance will re-attempt ignition a further 4-times then go to lockout.

When the set-point has been reached (the position of the heating temperature selector) as measured at the primary thermistor, the appliance will begin the modulation phase whereby the fan and gas valve will continuously modulate to maintain the set-point.

If the temperature continues to rise and exceeds the set-point by 6°C, the burner will shut down. A new ignition sequence will be enabled when the 5-minute anti-cycle has been performed and the temperature at the primary thermistor has dropped 6°C below the set-point.

NOTES

Any DHW request will always have priority over the heating request.

When the request for heating has been satisfied, the appliance pump and fan may continue to circulate to dissipate any residual heat within the appliance.

7.2.8 DHW MODE

When the ON/OFF selector is in the ON position and a DHW outlet is opened, the appliance will operate in the HW mode. The valve actuator will motor to the HW position (if a heating request was active) and the pump and fan will be activated via the flow temperature sensor. When the fan is sensed to be operating correctly, the ignition sequence commences. Ignition is sensed by the electronic circuitry to ensure flame stability at the burner.

Once successful ignition has been achieved, the electronic circuitry modulates the appliance output in order to achieve the DHW set-point (the

position of the DHW temperature selector) as measured at the DHW thermistor.

When the set-point has been reached, the appliance will begin the modulation phase whereby the fan and gas valve will continuously modulate to maintain the set-point.

If the temperature continues to rise and exceeds the set-point by 5°C, the burner will shut down until the temperature drops to set-point + 4°C, whereby a new ignition sequence will be enabled.

If the TSC function is active the set point will be overridden until/unless the appliance reaches the maximum operating temperature.

When the request for DHW has been satisfied, the appliance fan may continue to operate to dissipate any residual heat from within the appliance.

7.3 SERVICE MODE & PARAMETERS

To check or adjust the service parameters you must first access the service mode. This mode is only accessible in OFF mode. To access the service mode: push INFO and MODE buttons at the same time for 10 seconds to enter the adjusting menu.

The display shows “CodE” (see fig. 41). Push MODE button and select the service parameters code by turning the DHW temperature control and confirm it by pushing MODE button.

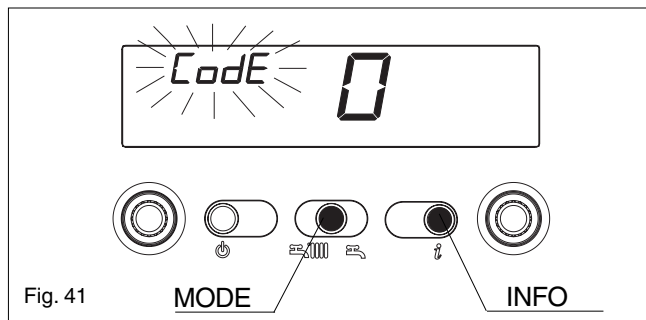

Fig. 41

7.3.1 PARAMETERS SETTING

Turn the DHW temperature control to display all parameters and their values (see fig. 42). When the required parameter is displayed, push the MODE button, the current (parameter) value will flash. To change the parameter value, rotate the DHW temperature control until the required value is displayed, push the MODE button to store the new value. To exit the service mode push INFO button.

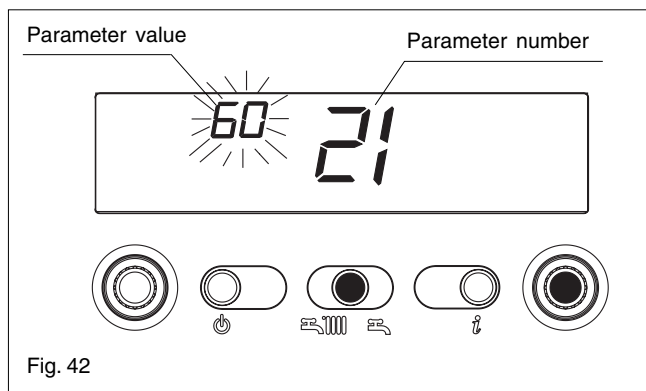

Fig. 42

PLANT

PARAMETER	UNIT	MIN	MAX	STEP	DEF.	INSTALLAT. SETTING
1 Gas type		1 (Natural gas)	2 (LPG)	1		
2 Boiler output		30 (30 kW) 34 (35 kW)		10-20 26-30 34-50	30 (28 HE) 34 (32 HE) 34 (36 HE)	
3 Building structure (adjust only if external sensor is fitted)	Min.	5 (light type of construction)	20 (heavy type of construction)	1	5	

DOMESTIC HOT WATER PARAMETERS

PARAMETER	UNIT	MIN	MAX	STEP	DEF.	INSTALLAT. SETTING
10 DHW-type		0 = OFF 1 = Instant water heater (combi) 2 = N/A 3 = N/A 4 = N/A 5 = N/A		1	1	
11 Max set-point for DHW (Instant water heater)	°C	40	60	1	60	
12 This parameter is not used on this model. Do not modify					60	
13 This parameter is not used on this model. Do not modify					80	
14 This parameter is not used on this model. Do not modify					5	

CENTRAL HEATING PARAMETERS

PARAMETER	UNIT	MIN	MAX	STEP	DEF.	INSTALLAT. SETTING
20 Central heating type		0 = OFF 1 = ON 2 = Unused 3 = 2 nd PUMP 4 = Unused 5 = Unused 6 = Unused		1	1 (ON)	
21 Max flow temperature 1 st CH	°C	40	80	1	80	
22 Min flow temperature 1 st CH	°C	20	39	1	39	
23 Max output CH (fan speed)	rpm	37 (3700*)	30 NG 56 56 34 60 60	1	28 HE 49 51 32 HE 55 54 36 HE 60 60	
24 Min output CH (fan speed)	rpm	30 NG 14 14 34 14 14	36 (3600*)	1	28 HE 14 14 32 HE 14 14 36 HE 14 14	
25 Differential heating positive	°C	2	10	1	6	
26 Differential heating negative	°C	2	10	1	6	
28 CH timer: force burner 75% after CH-start	Min	0	20	1	15	
29 CH timer: blocking time CH	Min	0	20	1	5	
30 CH timer on/off selection		0 (OFF)	1 (ON)	1	0 (OFF)	
31 Max flow temperature 2 nd CH	°C	40	80	1	80	
32 Min flow temperature 2 nd CH	°C	20	39	1	39	

FUNCTIONS

PARAMETER	UNIT	MIN	MAX	STEP	DEF.	INSTALLAT. SETTING
40 DHW thermostat		0 (OFF) 1 (AUTO) 2 (ON)		1	1 (AUTO)	
41 Pre-heating		0 (OFF) 1 (AUTO) 2 (ON)		1	1 (AUTO)	
42 S.A.R.A. Function		0 (OFF)	1 (AUTO)	1	1 (AUTO)	
43 S.A.R.A. Booster Function		0 (OFF)	1 (AUTO)	1	1 (AUTO)	
44 1 st CH circuit climatic Thermo-regulation ²		0 (OFF)	1 (AUTO)	1	1 (AUTO)	
45 Climatic curve selection on 1 st CH circuit ²		2,5	40	2,5	20	
46 2 nd CH circuit climatic Thermo-regulation ¹⁻²		0 (OFF)	1 (AUTO)	1	1 (AUTO)	
47 Climatic curve selection on 2 nd CH circuit ¹⁻²		2,5	40	2,5	20	
48 Unused		0 (OFF)	1 (AUTO)	1	0 (OFF)	
50 Unused		0 (OFF)	1 (ON)	1	1 (ON)	
51 Unused		0 (OFF)	1 (ON)	1	0 (OFF)	
52 Unused		0 (OFF)	1 (ON)	1	0 (OFF)	

GENERAL

PARAMETER	UNIT	MIN	MAX	STEP	DEF.	INSTALLAT. SETTING
61 DHW frost protection temperature	°C	0	10	1	4	
62 CH frost protection temperature	°C	0	10	1	6	
63 N/A	°C	0	10	1	6	
65 Unused					255	
85 Unused		0 (OFF)	1 (ON)	1	0 (OFF)	
86 Unused					0,6	

¹ Only with 2nd CH circuit

² Working only if an external sensor is fitted

* The value is shown on the display as rpm/100 (i.e. 3700/100 = 37)

7.4 ADJUSTING MODE & ADJUSTING THE GAS VALVE

THE GAS VALVE MUST BE SET-UP OR ADJUSTED WITH THE AID OF A PROPERLY CALIBRATED FLUE GAS ANALYSER.

Isolate the appliance from the electrical supply and remove the appliance casing as described in 4.7.1. Set the flue gas analyser to read CO₂ and insert the probe into the flue analysis test point (A, B fig. 40). Restore the electrical supply to the boiler and switch on the boiler.

To adjust the gas valve you must first access the adjusting mode. This mode is only accessible in STANDBY mode. To access the adjusting mode: push INFO and MODE buttons at the same time for 10 seconds to enter the adjusting menu.

The display shows "CodE" (see fig. 41). Push MODE button and select the adjust parameters password by turning the DHW temperature control and confirm it by pushing MODE button. The following functions are available in this mode.

* Only if outside sensor connected.

Par.	Action
01	set gas type
02	set boiler power
10	set DHW type
03*	type of building
45*	climatic curve selection
HP	absolute max fan speed selection
LP	absolute min fan speed selection
SP	start-up fan speed
HH	force burner at max power
LL	force burner at min power
MM	force burner at medium power
23	max output CH (fan speed)
24	min output CH (fan speed)

7.4.1 GAS TYPE SETTING - 1

Select the parameter 1 by turning the DHW temperature control; push MODE button, it is possible to set gas type: 1 (natural gas) - 2 (LPG), by turning the DHW temperature control. Push MODE button to store the gas type selected.

7.4.2 BOILER OUTPUT - 2

Select the parameter 1 by turning the DHW temperature control; push MODE button, it is possible to set the boiler output: 26 (25 kW) - 30 (30 kW) - 34 (35 kW), by turning the DHW temperature control. Push MODE button to store the gas type selected.

ATTENTION

Gas type and boiler output **must be** according to the boiler design specification.

Vokera has no responsibility if the gas type and boiler output are set not according to the appliance specification.

7.4.3 ABSOLUTE MAX FAN SPEED - HP

Select the parameter HP by turning the DHW temperature control; push MODE button, it is possible to set the absolute max fan speed that is related to gas type and boiler output. Modify this parameter only if strictly necessary.

The value is shown on the display as rpm/100 (i.e. 3600/100 = 36).

 **For Linea 28HE and 32HE it is necessary to adjust the parameter 23 (see 7.4.9).**

7.4.4 ABSOLUTE MIN FAN SPEED - LP

Select the parameter LP by turning the DHW temperature control; push MODE button, it is possible to set the absolute min fan speed that is related to gas type and boiler output. Modify this parameter only if strictly necessary.

The value is shown on the display as rpm/100 (i.e. 3600/100 = 36). The set value automatically modifies the min value of parameter 24.

7.4.5 START-UP FAN SPEED - SP

Select the parameter SP by turning the DHW temperature control; push MODE button, it is possible to set the start-up fan speed. Modify this parameter only if strictly necessary.

The value is shown on the display as rpm/100 (i.e. 3600/100 = 36).

7.4.6 GAS VALVE MAXIMUM SETTING - HH

Select the HH parameter by turning the DHW temperature control; the boiler starts at the maximum power, the CO₂ reading should be as shown in the table below (for LPG see 9.2).

Power	CO ₂ @ max	CO ₂ @ min
Linea 28HE	9.0%	9.3%
Linea 32HE	9.0%	9.0%
Linea 36HE	9.0%	9.0%

If the CO₂ reading is correct, pass to gas valve minimum setting (7.4.7). If the CO₂ reading is incorrect, the maximum gas pressure must be adjusted as follows:

- using a suitable screwdriver, very slowly turn the maximum adjustment screw (see fig. 43) – clockwise to decrease, counter clockwise to increase – until the correct value is displayed on the CO₂ analyser (allow time for the analyser to stabilise).

IMPORTANT

A GAS SOUNDNESS CHECK MUST BE CARRIED OUT.

7.4.7 GAS VALVE MINIMUM SETTING - LL

Select the LL parameter by turning the DHW temperature control. The boiler starts at the minimum power, the CO₂ reading should be as shown in the table above.

If the CO₂ reading is correct, pass to gas valve final setting (7.4.8). If the CO₂ reading is incorrect, the minimum gas pressure must be adjusted as follows:

- using a 2,5 Allen key, very slowly turn the minimum adjustment screw (see fig. 43) – clockwise to increase, counter clockwise to decrease - until the correct value is displayed on the CO₂ analyser (allow time for the analyser to stabilise).

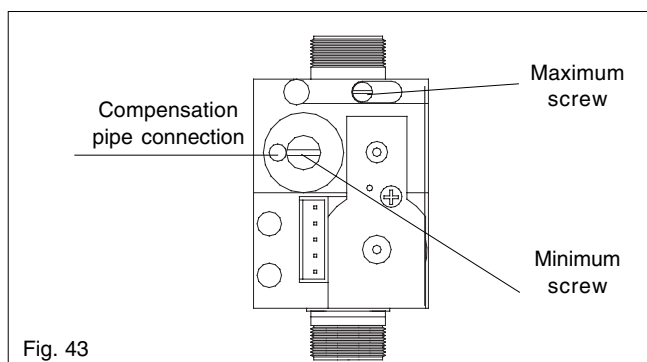

Fig. 43

7.4.8 GAS VALVE FINAL SETTING - MM

Select the MM parameter by turning the DHW temperature control, the boiler starts at the medium power and it is possible to change the power of the boiler turning the CH temperature control in order to check the CO₂ in the overall range of the boiler.

7.4.9 MAXIMUM OUTPUT CH (FAN SPEED) - 23

Select the parameter 23 by turning the DHW temperature control. Push MODE button and modify the maximum fan speed as indicated in the table page 28 by turning the DHW temperature control. Push MODE button to store the value.

7.4.10 MINIMUM OUTPUT CH (FAN SPEED) - 24

Select the parameter 24 by turning the DHW temperature control. Push MODE button, it is possible to modify the minimum fan speed by turning the DHW temperature control. Push MODE button to store the value.

7.5 COMBUSTION ANALYSIS TEST

A combustion analysis check can easily be carried out on the appliance via the test points located on the top of the appliance, however you must check that the CO₂ values are set correctly (see 7.4).

- Insert the flue gas analyser probe into the flue gas test point (see fig. 43).
- Operate the boiler in HH - LL and compare the values with those shown in 7.4.6. If different adjust the gas valve according to 7.4.6. and 7.4.7.

7.6 CHECKING THE EXPANSION VESSEL

Carry out the component removal procedure as described in 6.4. You must ensure that the boiler is completely drained of water.

Using a suitable pressure gauge, remove dust cap on expansion vessel and check the charge pressure. The correct charge pressure should be 1.0 bar ± 0.1 bar. If the charge pressure is less, use a suitable pump to increase the charge.

NOTE

You must ensure the drain valve is in the open position whilst re-charging takes place. Replace the dust cap and carry out the relevant commissioning procedure (section 5).

7.7 EXTERNAL FAULTS

Before carrying out any faultfinding or component replacement, ensure the fault is not attributable to any aspect of the installation.

7.7.1 INSTALLATION FAULTS

Symptom	Possible causes
No ignition	Check wiring. Check electrical supply
No hot water	Check hot/cold pipe work is not reversed
No central heating	Check wiring of time clock and/or room thermostat

Fault code	Possible causes
10	Gas supply problem. Gas line requires purging. Reversed polarity. Broken, internal flue joint
30	Debris in flue system.
40	Insufficient water pressure. Air in boiler

7.8 ELECTRICAL CHECKS

Any electrical checks must be carried out by a suitably qualified person.

7.8.1 EARTH CONTINUITY TEST

Isolate the appliance from the electrical supply, and using a suitable multi-meter carry out a resistance test. Connect test leads between an appliance earth point and the earth wire of the appliance supply cable. The resistance should be less than 1 OHM. If the resistance is greater than 1 OHM check all earth wires and connectors for continuity and integrity.

7.8.2 SHORT CIRCUIT CHECK

Isolate the appliance from the electrical supply, and using a suitable multi-meter, carry out a short circuit test between the Live & Neutral connections at the appliance terminal strip (fig. 17).

Repeat above test on the Live & Earth connections at the appliance terminal strip (fig. 17).

NOTE

Should it be found that the fuse has failed but no fault is indicated, a detailed continuity check will be required to trace the fault. A visual inspection of components may also assist in locating the fault.

7.8.3 POLARITY CHECK

With the appliance connected to the electrical supply and using a suitable multimeter, carry out the following voltage tests:

- connect test leads between the Live & Neutral connections at the appliance terminal strip (fig. 17). The meter should read approximately 230V ac. If so proceed to next stage. If not, see 7.8.4.
- connect test leads between the Live & Earth connections at the appliance terminal strip (fig. 17). The meter should read approximately 230V ac. If so proceed to next stage. If not, see 7.8.4.
- connect test leads between the Neutral & Earth connections at the appliance terminal strip (fig. 17). The meter should read approximately 0 – 15Vac. If so polarity is correct. If not, see 7.8.4.

7.8.4 REVERSED POLARITY OR SUPPLY FAULT

Repeat the above tests at the appliance isolator, if testing reveals correct polarity and/or supply at the isolator, re-check wiring and connections between the isolator and the appliance.

If tests on the isolator also reveal reversed polarity or a supply fault, consult the local electricity supplier for advice.

7.8.5 RESISTANCE TO EARTH CHECK

Isolate the appliance from the electrical supply, and using a suitable multi-meter carry out a resistance test. Connect test leads between the Live & Earth connections at the appliance terminal strip (fig. 17). If the meter reads other than infinity there is a fault that must be isolated, carry out a detailed continuity check to identify the location of the fault.

IMPORTANT

These series of checks must be carried out before attempting any faultfinding procedures on the appliance. On completion of any task that required the disconnection and re-connection of any electrical wiring or component, these checks must be repeated.

7.9 FAULT FINDING

Before attempting any faultfinding, the electrical checks as detailed in 7.8 must be carried out.

Isolate the appliance from the electrical supply. Disconnect any external controls from terminal plug M6 (Fig. 48), and insert a link-wire between the two Black wires at terminal plug M6 (Fig. 48).

NOTE

Restore the electrical supply to the boiler and turn the selector switch to the on position. The boiler should now function as described in section 7.2. Should the boiler fail to respond, the internal fuses and connectors should be checked to ensure integrity and continuity. If the boiler still fails to respond, refer to the detailed faultfinding flowcharts overleaf.

7.10 TEMPORARY FAULT CODES

The built-in fault diagnostic system automatically displays a unique fault code that can be used to determine why the boiler has temporarily locked out. When the boiler displays a temporary fault code, the appropriate code is shown flashing on the display, accompanied by the symbol .

7.11 FINAL FAULT CODES

When the boiler displays a final fault code, the appropriate code is shown flashing on the display, accompanied by the symbol  (RESET).

7.11.1 CODE ERROR +  (RESET) ONLY

To reset the boiler, push  button. If the boiler starts without any problems, the lock-out is probably due to an accidental situation.

7.11.2 CODE ERROR +  (RESET) + 

Refer to the following section and the detailed fault finding flowcharts overleaf.

Code	Reason
11	false flame
12	restart ignition
13	check the wiring harness
23	check the wiring harness
25	high limit flow temperature probe
27	high limit return temperature probe
31	internal fault
35	fan error
36	internal fault
41	low water pressure
60	DHW NTC error
71	flow NTC error (2 nd CH)
77	over heat underfloor thermostat (2 nd CH)
78	flow/return ΔT error (2 nd CH)
93	condensate level high
95	condensate sensor error

Code	Reason
10	no flame detected
14	check the wiring harness
15	false flame
20	high limit thermostat/burner
21	check the wiring harness
22	check the wiring harness
24	high limit flow temperature probe
26	high limit return temperature probe
28	flow/return ΔT error
29	check the wiring harness
30	wrong parameter from the factory
33	fan error (low rpm)
34	fan error (start-up)
37	fan error (high rpm)
38	wrong parameter from the factory
40	low water pressure
42	pressure transducer fault
50-59	internal PCB failure
70	flow NTC error (2 nd CH)
72	return NTC error (2 nd CH)
74	flow temperature too high /flow sensor error (2 nd CH)
79	flow/return ΔT error (2 nd CH)
80-83	internal fault
92	condensate level high
94	condensate sensor error

FAULT CODES 1x
Fault codes 1x appear when the burner has failed to ignite or the flame supervision system has failed to detect a flame. <ul style="list-style-type: none"> ● Check incoming gas supply ● Check spark electrode ● Check polarity ● Check integrity of flue system ● Check gas valve ● Check ignition control PCB

FAULT CODES 2x
<ul style="list-style-type: none"> ● Check wirings

FAULT CODES 3x
Fault codes 3x appear if the boiler or flue system has developed a fault. <ul style="list-style-type: none"> ● Check operation of fan ● Check flue system

FAULT CODES 4x
Fault codes 4x appear if the pressure in the boiler is low. <ul style="list-style-type: none"> ● Check water pressure ● Check water pressure sensor

FAULT CODES 5x
Fault codes 5x appear if a problem with the main board exists. <ul style="list-style-type: none"> ● Check parameters ● Check gas valve ● Check PCB

FAULT CODES 6x
Fault codes 6x appear if a problem exists with the secondary (DHW) thermistor. <ul style="list-style-type: none"> ● Check thermistor ● Check wiring continuity

FAULT CODE 7x
Fault codes 7x appear if a problem exists with the flow temperature (2 nd CH). <ul style="list-style-type: none"> ● Check thermistor ● Check wiring continuity

FAULT CODE 8x
PCB fault

FAULT CODE 9x
Fault codes 9x appear if the condensate trap/pipe has become blocked. <ul style="list-style-type: none"> ● Ensure the condensate trap is clear ● Ensure the condensate pipe is clear

SECTION 8 WIRING DIAGRAMS

8.1 EXTERNAL WIRING

The appliance comes with a factory fitted link to allow basic operation of the boiler via the mode selector switch. If external controls are to be added to the system, they must be connected to the appliance as shown in the following diagrams. For advice on controls that are not featured in this book, please contact Vokera technical on 0870 333 0520.

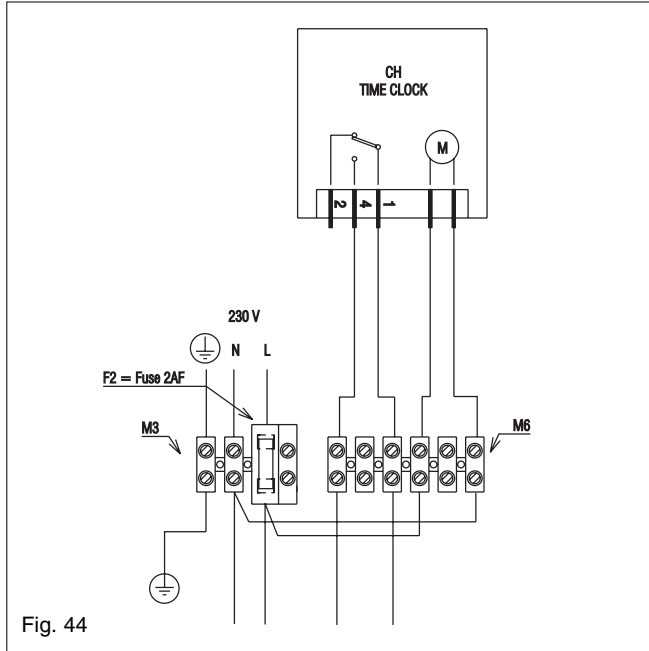

Fig. 44

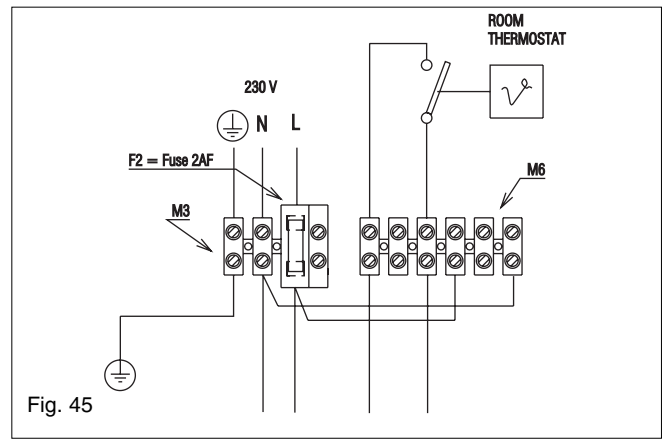

Fig. 45

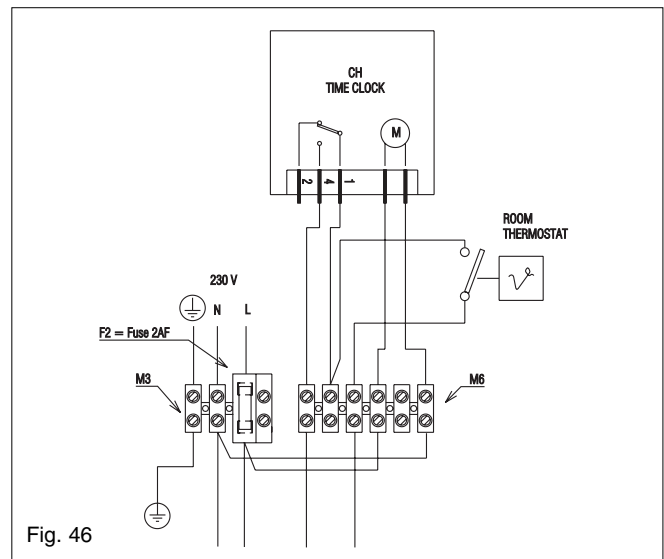

Fig. 46

8.2 TYPICAL CONTROL APPLICATIONS

The appliance can be used with the following controls:

- Vokera room thermostat (part no. 011)
- Vokera external sensor. (Part no. 2359259)
- Single-channel, voltage-free time clocks
- Programmable room thermostats.

In addition, the appliance can be used in conjunction with a typical 'S'-Plan system, please contact Vokera technical for further detailed instruction.

NOTE

This appliance is not suitable for use with 'Y'-Plan systems.

8.3 VOKERA ROOM THERMOSTAT

Connect the Vokera room thermostat to the appliance as detailed in fig. 45.

The Vokera room thermostat can be used as detailed in fig. 46.

8.4 OTHER DEVICES

Fig. 47 details typical devices that are suitable for this appliance:

- **TBT**: low temperature thermostat for underflow heating, a safety device that prevent overheating
- **SE**: outside sensor, a NTC sensor that automatically calculates the flow temperature according to the outside temperature
- **P2**: external pump, a supplementary pump that can be managed directly from the boiler in order to satisfy larger systems with high flow rate or high pressure drop (i.e. underfloor heating).

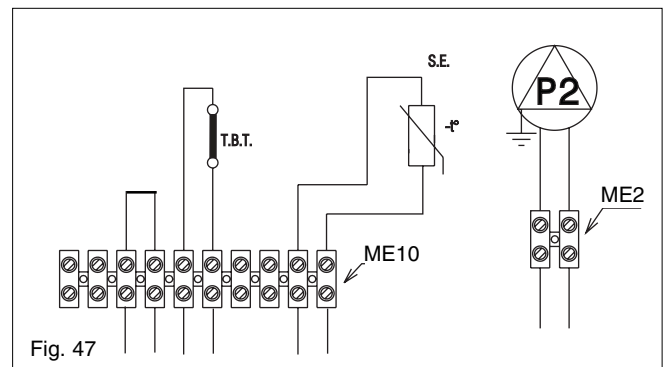

Fig. 47

Contact the controls manufacturer and/or Vokera technical department should you require more specific information on the suitability of a particular control. Further guidance on the recommended practice for the installation of external controls, can be found in CHeSS – HC5/HC6 (www.energy-efficiency.gov.uk).

FUNCTIONAL DIAGRAM

NOTE. L-N-E CONNECTION MUST NOT BE INTERCHANGED
CONTROL SWITCHING OF TIME CLOCK AND ROOM THERMOSTAT RATED IS 230 V.a.c.

Fig. 48

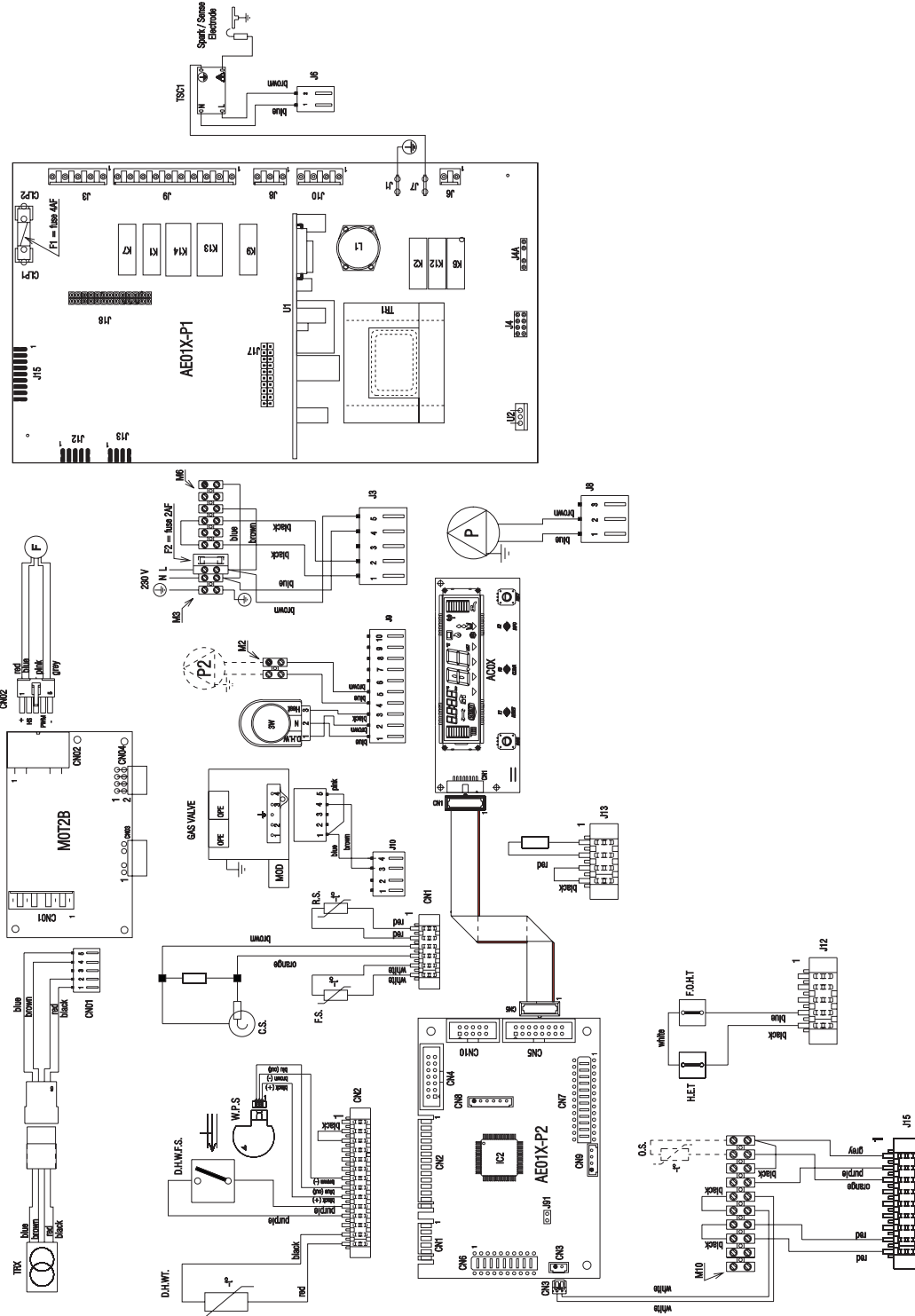

Key

- | | | | |
|-----------|--------------------------------|----------|---|
| TRX | Fan transformer | RS | Return thermostat |
| F | Fan | AE01A-P1 | Master board |
| P | Pump | AE01A-P2 | Auxiliary board control |
| P2 | Supplementary external pump | MOT2B | Motor control board |
| F1 | Fuse 4A F | AC0X | Display board |
| F2 | Fuse 2A F | K9 | Pump relay |
| OPE | Gas valve solenoids | K13 | 3 V1 relay |
| S.S.E | Spark/Sense electrode | K14 | 3 V2 relay |
| MOD | Modulator | K1 | Not used |
| D.H.W.F.S | Domestic hot water flow switch | K7 | Not used |
| D.H.W.T | Domestic hot water temperature | K6 | Flame sensing relay |
| C.S. | Condensate sensor | K12 | Power supply for brushless motor relay |
| 3W | 3 way motor | K2 | Power supply for discharge TSC1 transformer |
| G.V. | Gas valve | F.O.H.T. | Flow over heat thermostat |
| TSC1 | Sparkling transformer | H.E.T. | Heat exchanger thermostat |
| TR1 | Main transformer | M3-M6 | Terminal strip for electrical connection high power |
| O.S | Outside sensor | M10 | Terminal strip for electrical connection low power |
| WPS | Water pressure sensor | M2 | Terminal strip connection secondary pump |
| FS | Flow thermostat | | |

PCB	PLUG or CONNECTION	DESIGNATION
AE01A-P2	CN1	Flow, return, condense sensor
AE01A-P2	CN2	DHW sensor, DHW flow switch, water pressure sensor
AE01A-P2	CN3	Underflow system overheat temperature
AE01A-P2	CN4	RS232 PC interface
AE01A-P2	CN5	Display board connection
AE01A-P2	CN6	AE01A-P1 connection
AE01A-P2	CN7	AE01A-P1 connection
AE01A-P2	CN8	Unused
AE01A-P2	CN9	Unused
AE01A-P2	CN10	Unused

PCB	PLUG or CONNECTION	DESIGNATION
AE01A-P1	J1	Earth
AE01A-P1	J2	Unused
AE01A-P1	J3	Incoming 230V supply, heat request
AE01A-P1	J4	Unused
AE01A-P1	J5	Unused
AE01A-P1	J6	24V sparking transformer
AE01A-P1	J7	Earth sparking transformer
AE01A-P1	J8	230V pump
AE01A-P1	J9	230V 3-way valve, supplementary external pump
AE01A-P1	J10	230V gas valve
AE01A-P1	J11-J12-J13-J14	Unused
AE01A-P1	J15	Outside sensor

PCB	PLUG or CONNECTION	DESIGNATION
MOT2B	CN01	External transformer connection
MOT2B	CN02	Fan connection
MOT2B	CN03-CN04	Connection to main PCB

Strip	PLUG or CONNECTION	DESIGNATION
High voltage	M3	Incoming 230V supply
High voltage	M6	Heat request, 230V clock supply
High voltage	M2	Supplementary external pump
Low voltage	M10	Outside sensor, underflow system overheat temperature

PCB	PLUG or CONNECTION	DESIGNATION
Gas valve	OPE	Plug J3 on AE01A-P1
Fan	F	Plug CN02 on MOT2B
Condense sensor	C.S.	Plug CN1 on AE01A-P2
Flow sensor	F.S.	Plug CN1 on AE01A-P2
Return sensor	R.S.	Plug CN1 on AE01A-P2
Pump	P	Plug J8 on AE01A-P1
External transformer	⊕	Plug CN01 on MOT2B
Hot water outlet sensor	DHWT	Plug CN2 on AE01A-P2
External sensor (if fitted)	O.S.	Plug J15 on AE01A-P1
Actuator	3W (M)	Plug J9 on AE01A-P1
230V connection for time clock or room thermostat	R.T.	Plug J3 on AE01A-P1

SECTION 9 EXPLODED DIAGRAMS

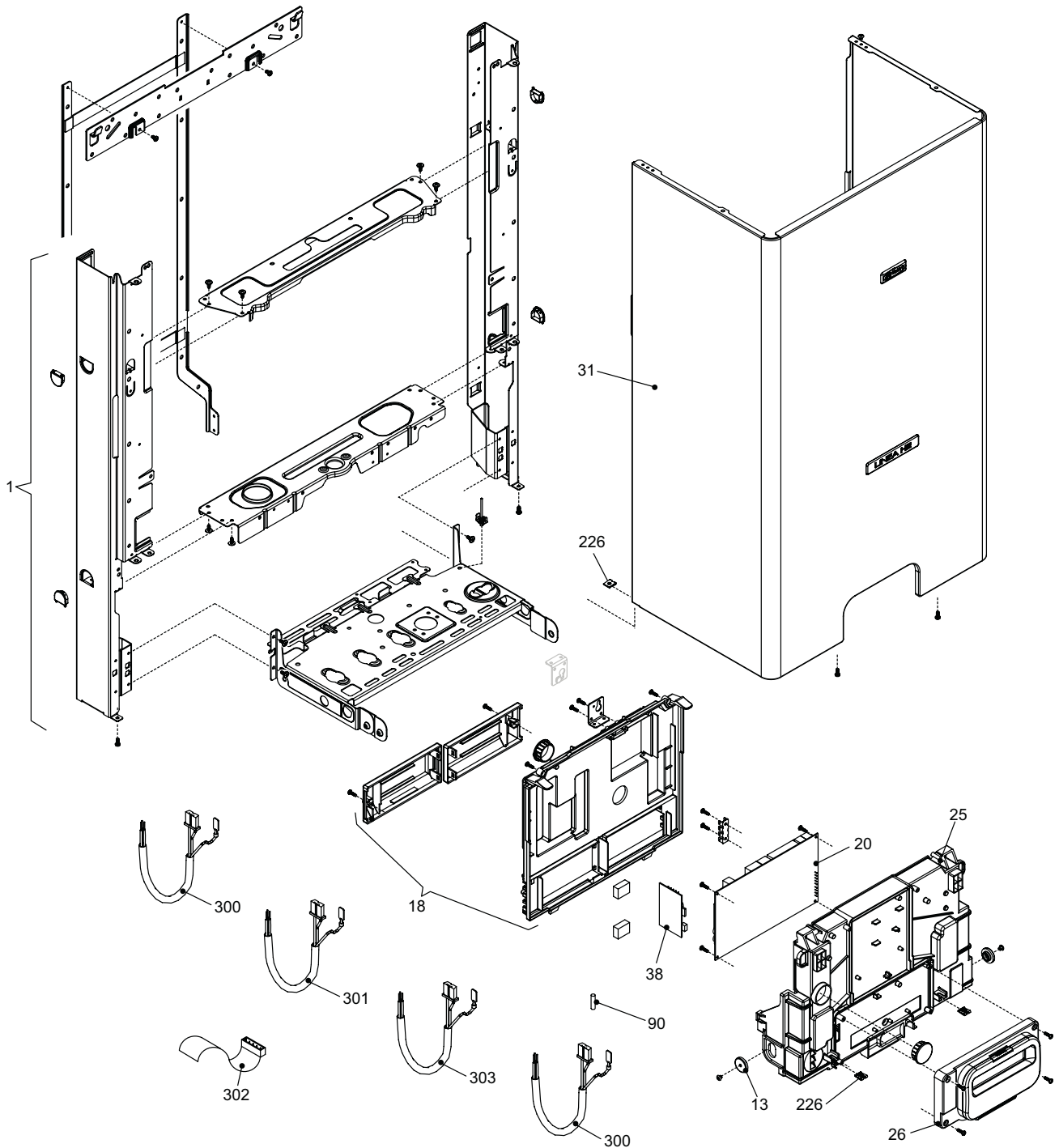

POS.	DESCRIPTION	28 HE	32 HE	36 HE
1	Frame assembly	01005365	01005365	01005365
13	Pin	10023044	10023044	10023044
18	Cover assembly	10026239	10026239	10026239
20	Printed Circuit Board	10026240	10026240	10026240
25	Front cover assembly	10025842	10025842	10025842
26	Instrumental panel	10029365	10029365	10029365
31	Case	10026241	10026241	10026241
38	Driver PCB	10027200	10027200	10027200
90	Fuse	3478	3478	3478
226	Edge clip	5128	5128	5128
300	Wiring harness	10026330	10026330	10026330
301	Wiring harness	10026333	10026333	10026333
302	Flat cable	10026341	10026341	10026341
303	Wiring harness	10027360	10027360	10027360
304	Wiring harness	10027158	10027158	10027158

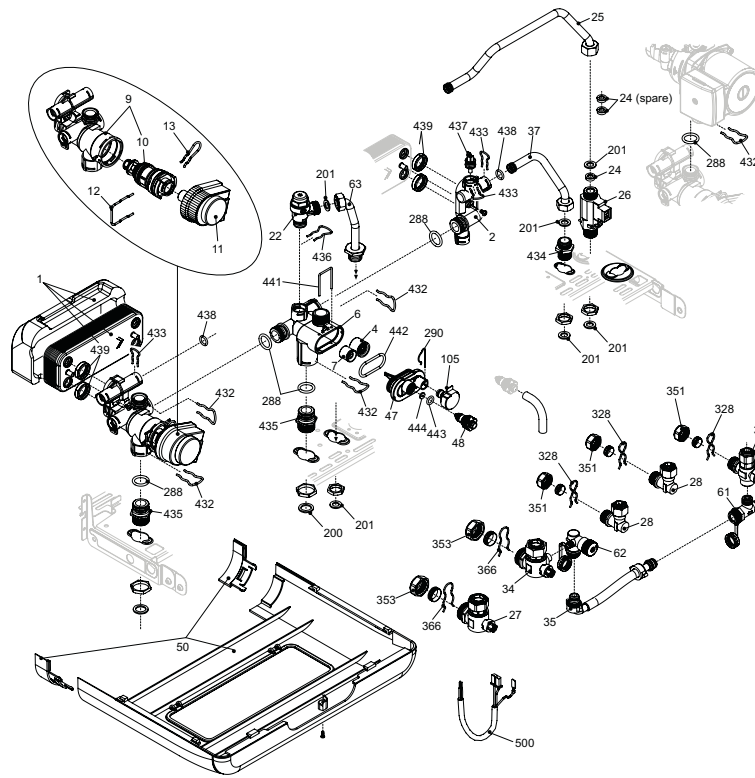

POS.	DESCRIPTION	28 HE	32 HE	36 HE
1	Domestic water heat exchanger	1957	1957	0024627
2	Connection	10024640	10024640	10024640
4	Non return valve	10025056	10025056	10025056
6	By-pass casing	10024641	10024641	10024641
7	By-pass valve	2047	2047	2047
9	Heating manifold and cartridge	10026508	10026508	10026508
10	3 way valve cartridge	10025305	10025305	10025305
11	Motorized valve	10025304	10025304	10025304
12	Fixing fork wrench	10025450	10025450	10025450
13	Fixing fork wrench	10025449	10025449	10025449
22	Safety valve	10025055	10025055	10025055
24	Flow governor	10024987	10025080	10025080
24	Flow governor (spare)	10024462	10024462	10024462
24	Flow governor (spare)	10020041	10020041	10020041
25	Pipe	10025839	10025839	10025839
26	DHW actuator	10022349	10022349	10022349
27	Heating cock	1789	1789	1789
28	Connection	1790	1790	1790
30	Heating cock	10023567	10023567	10023567
34	Heating cock	10023566	10023566	10023566
35	Flexible pipe	10023570	10023570	10023570
37	Pipe	10025840	10025840	10025840
47	By-pass casing cover	10024643	10024643	10024643
48	Discharge cock	10024646	10024646	10024646
50	Connections cover	10027685	10027685	10027685
61	Non return valve	10023569	10023569	10023569
62	Filling cock	10023568	10023568	10023568
63	Pipe	10026228	10026228	10026228
105	Pressure transductor	10027132	10027132	10027132
200	Washer	5023	5023	5023
201	Washer	5026	5026	5026
288	Washer	6898	6898	6898
290	Clip	2165	2165	2165
328	Clip	1890	1890	1890
351	Nut	1823	1823	1823
353	Nut	1824	1824	1824
366	Clip	1820	1820	1820
432	Clip	10024958	10024958	10024958
433	Clip	10024986	10024986	10024986
434	Nipple	10024985	10024985	10024985
435	Connection	10025059	10025059	10025059
436	Clip	10025062	10025062	10025062
437	NTC Sensor	10025061	10025061	10025061
438	O-Ring	10024988	10024988	10024988
439	Washer	10025067	10025067	10025067
441	Clip	10025063	10025063	10025063
442	O-Ring	10025065	10025065	10025065
443	O-Ring	10025064	10025064	10025064
444	Washer	10025066	10025066	10025066
500	Wiring harness	10026331	10026331	10026331

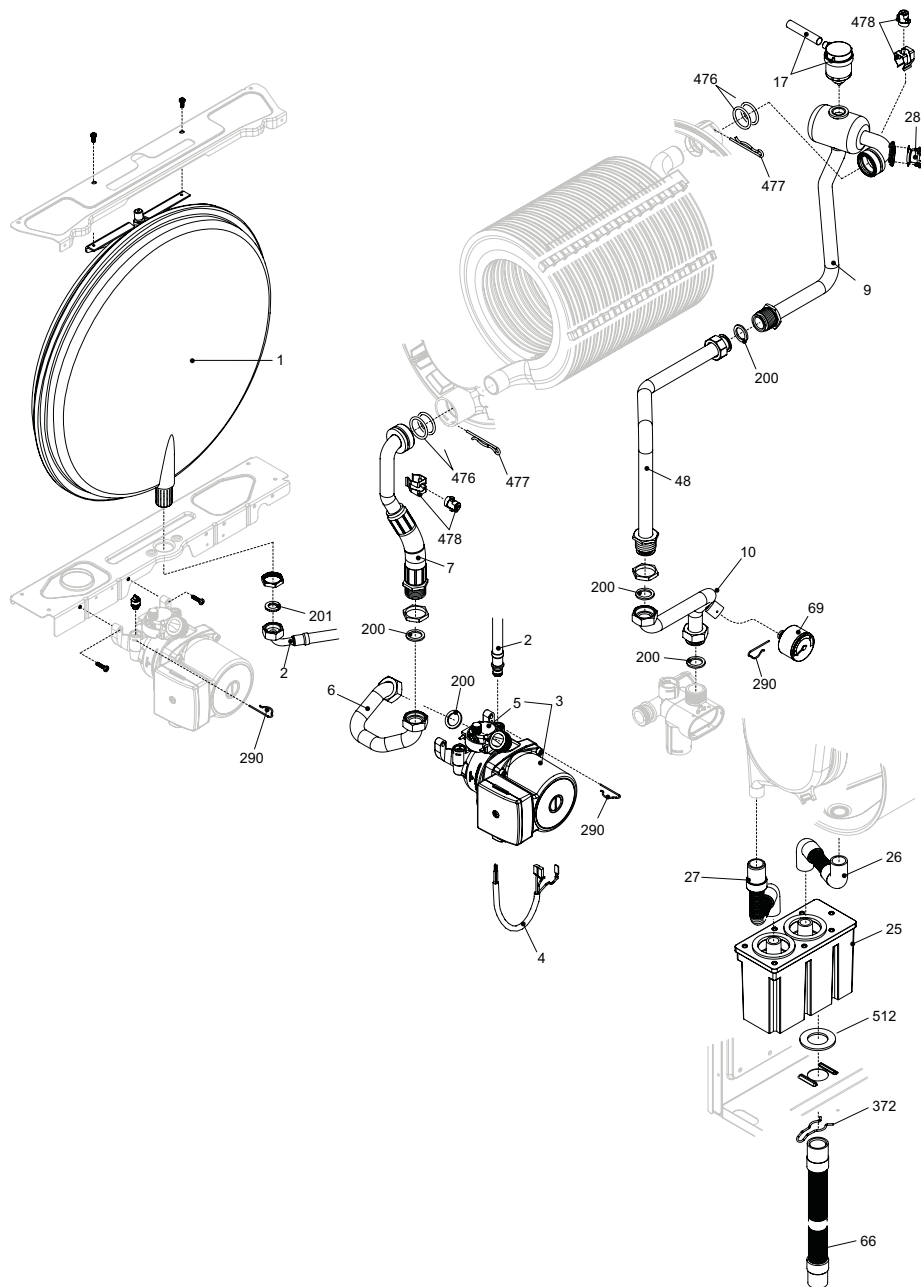

POS.	DESCRIPTION	28 HE	32 HE	36 HE
1	Expansion vessel	2573	2573	2573
2	Flexible pipe	10025188	10025188	10025188
3	Circulation pump	10024957	10024957	10027258
4	Pump cable	10026338	10026338	10026338
5	Automatic air vent bottle	10025485	1002548	10025485
6	Pipe	10026264	10026264	10026264
7	Pipe	10026267	10026267	10026267
9	Pipe	10029457	10029458	10029458
10	Pipe	10027146	10027146	10027146
17	Air vent bottle	10029306	10029306	10029306
25	Siphon	10027190	10027190	10027190
26	Flexible pipe	10027191	10027191	10027191
27	Flexible pipe	10027192	10027192	10027192
66	Flexible pipe	10026272	10026272	10026272
69	Pressure gauge	10027135	10027135	10027135
200	Washer 24 x 17	5023	5023	5023
201	Washer 18,5 x 11	5026	5026	5026
287	Limit thermostat	2258	2258	2258
290	Clip	2165	2165	2165
372	Clip	2588	2588	2588
476	O-Ring	10026324	10026324	10026324
477	Clip	10026269	10026269	10026269
478	NTC Sensor	10026273	10026273	10026273
512	Washer	10027193	10027193	10027193

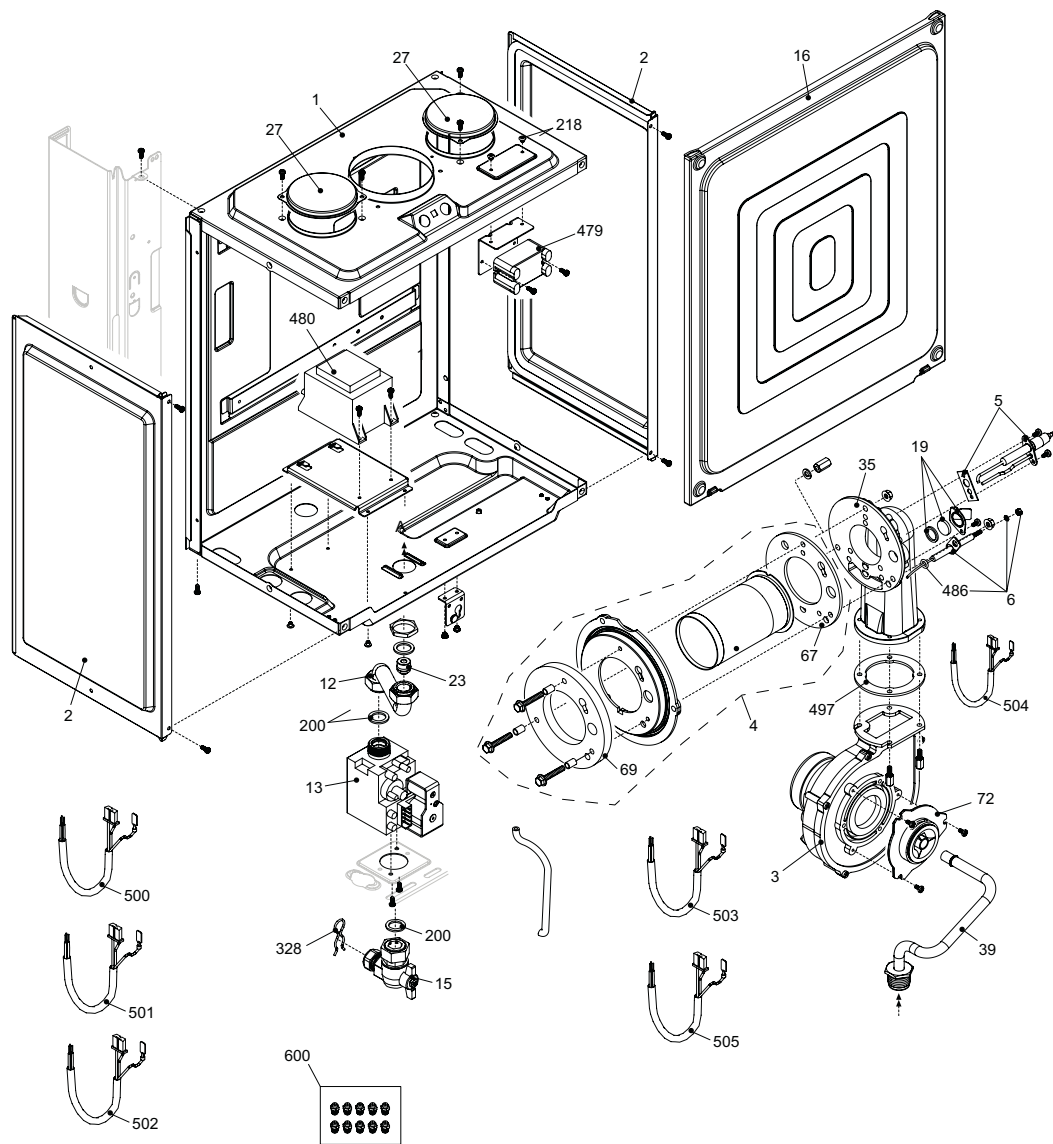

POS. DESCRIPTION

		28 HE	32 HE	36 HE
1	Air box bottom	10027175	10027175	10027175
2	Ambidx air box side	10026231	10026231	10026231
3	Fan	10027316	10027316	10027051
4	Burner assembly	10026548	10026548	10026548
5	Spark electrode	2192	2192	2192
6	Detection electrode	10026316	10026316	10026316
12	Gas pipe	10026318	10026318	10026318
13	Gas valve	10028538	10028538	10028538
15	Gas cock	10020897	10020897	10020897
16	Air box cover	10026230	10026230	10026230
19	Glass assembly	10026328	10026328	10026328
23	N.g. Jet	10027161	10027161	10027162
27	Hole cap	10023805	10023805	10023805
35	Air/gas conveyor	10026309	10026309	10026309
39	Gas pipe	10026317	10026698	10027196
67	Washer	10026322	10026322	10026322
69	Tryton	10027089	10027089	10027089
72	Mixer	10024295	10024295	10024295
200	Washer	R5023	5023	5023
328	Clip	1890	1890	1890
479	Transformer	10026237	10026237	10026237
480	Transformer	10026236	10026236	10026236
486	O-Ring	10026235	10026235	10026235
497	Fun washer	10026796	10026796	10026796
500	Wiring harness	10026332	10026332	10026332
501	Wiring harness	10026337	10026337	10026337
502	Wiring harness	10026336	10026336	10026336
503	Wiring harness	10026339	10026339	10026339
504	Spark cable	10026558	10026558	10026558
505	Wiring harness	10024121	10024121	10024121
600	LPG conversion kit	01005389	01005390	01005390

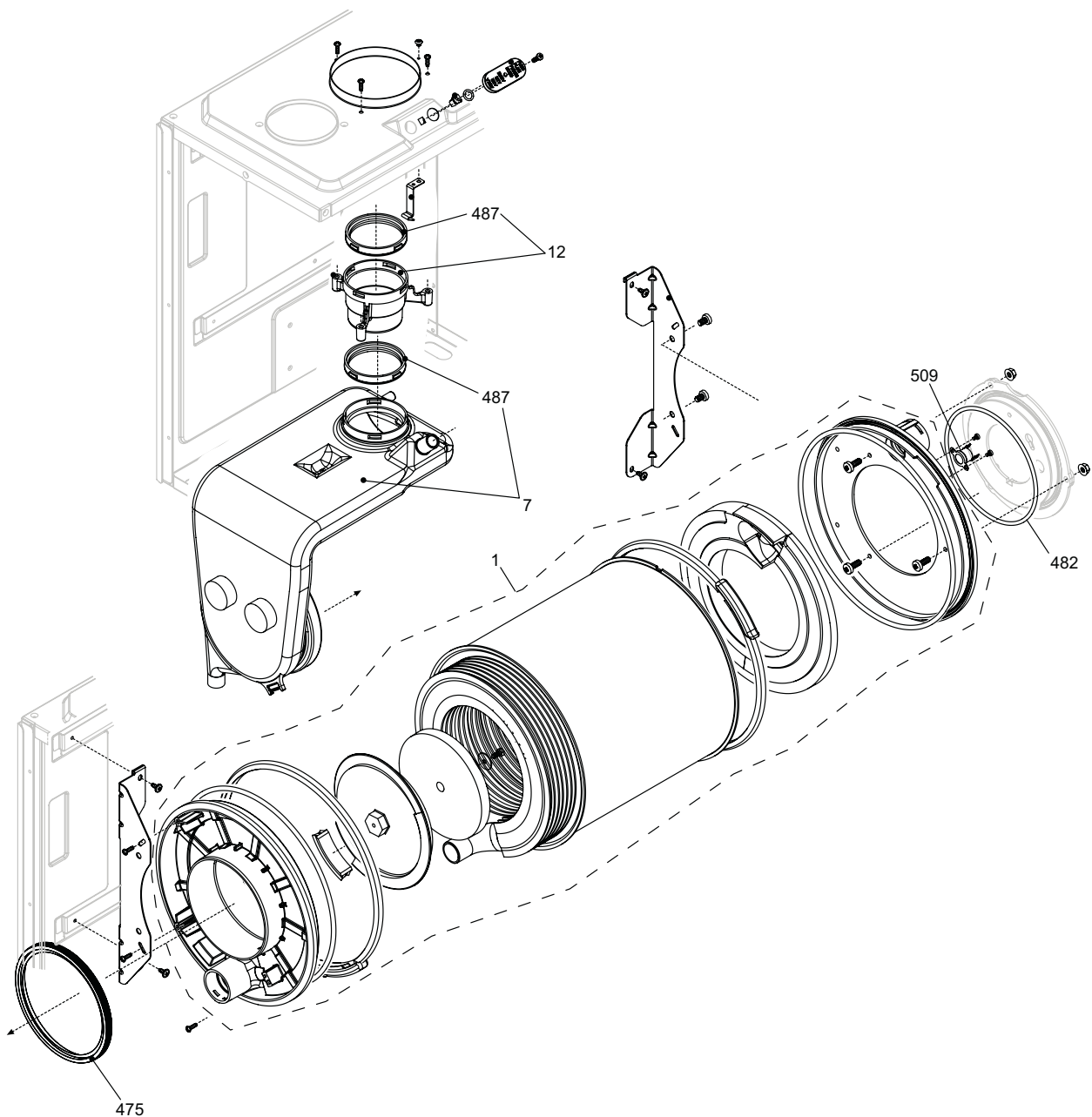

POS.	DESCRIPTION	28 H	32 HE	36 HE
1	Condensing exchanger assembly	01005366	01005369	01005369
7	Conveyor assembly	10026310	10026310	10026310
12	Flue drain connection	10028421	10028421	10028421
475	Washer	10026323	10026323	10026323
482	Washer	10026366	10026366	10026366
487	Washer	10026345	10026345	10026345
509	Limit thermostat	1002698	10026982	10026982

SECTION 10 L.P.G. INSTRUCTIONS

10.1 RELATED DOCUMENTS

BS 6798		INSTALLATION OF BOILERS OF RATED INPUT NOT EXCEEDING 60 kW
BS 5449	PART 1	FORCED CIRCULATION HOT WATER SYSTEMS
BS 5446		INSTALLATION OF GAS HOT WATER SUPPLIES FOR DOMESTIC PURPOSES
BS 5440	PART 1	FLUES
BS 5482	PART 1	DOMESTIC BUTANE & PROPANE GAS BURNERS IN PERMANENT DWELLINGS

10.2 TECHNICAL DATA

Gas Pressures	Linea 28HE	Linea 32HE	Linea 36HE
Inlet pressure	37.0 mbar	37.0 mbar	37.0 mbar
Maximum gas rate	2.33 kg/h	2.33 kg/h	2.69 kg/h
Minimum gas rate	0.47 kg/h	0.54 kg/h	0.54 kg/h
Injector size (quantity)	1 x Ø 4.7 mm	1 x Ø 5.0 mm	1 x Ø 5.0 mm
Fan speed @ max output (rpm) DHW	6.000	6.000	6.000
Fan speed @ max output (rpm) HTG	5.100	5.400	6.000
Fan speed @ min output (rpm)	1.400	1.400	1.400
Flue details (coaxial)	Linea 28HE	Linea 32HE	Linea 36HE
Maximum horizontal flue length (60/100mm)	7.80	7.80	7.80
Maximum vertical flue length (60/100mm)	8.80	8.80	8.80
Flue details (twin pipes)	Linea 28HE	Linea 32HE	Linea 36HE
Maximum horizontal flue length (80mm + 80mm)	40 + 40	35 + 35	50 + 50
Maximum vertical flue length (80mm + 80mm)	40 + 40	35 + 35	50 + 50
Efficiency	Linea 28HE	Linea 32HE	Linea 36HE
SEDBUK (%)	90.2 (A)	91.1 (A)	90.03 (A)
Emissions	Linea 28HE	Linea 32HE	Linea 36HE
NO _x (max-min)	88,3 - 70,6 mg/kWh	88,3 - 70,6 mg/kWh	123,6 - 105,9 mg/kWh
CO (max-min)	204,3 - 43,0 mg/kWh	236,5 - 21,5 mg/kWh	279,5 - 43,0 mg/kWh
CO ₂ (max-min)	10.0 - 10.30 %	10.0 - 10.0 %	10.0 - 10.0 %
CO/CO ₂ ratio (max)	0.002 to 1	0.002 to 1	0.002 to 1
CO/CO ₂ ratio (min)	0.0004 to 1	0.0004 to 1	0.0004 to 1

10.3 CONVERTING THE APPLIANCE GAS TYPE

To convert the appliance to another gas type it is necessary to change the burner injector and adjust the gas valve. It is also necessary to enter the appliance engineer mode and change the fan speed at the maximum output.

- To change the injector see 6.12.1
- To change parameters see 7.3.1
- To adjust CO₂ value see 7.4.1-2

10.4 GAS SUPPLY

The gas supply must be connected to the appliance by a competent LPG installer and must be of sufficient size to supply the appliance at its maximum output. An existing supply must be checked to ensure that it is of adequate size to deal with the maximum rated input of this and any other appliances that it serves.

10.5 GAS SUPPLY INSTALLATION

The entire installation including the meter must be purged and checked for gas soundness.

10.6 ADJUSTING THE GAS VALVE

THE GAS VALVE MUST BE SET-UP OR ADJUSTED WITH THE AID OF A PROPERLY CALIBRATED FLUE GAS ANALYSER.

Isolate the appliance from the electrical supply and remove the appliance casing as described in 4.7.1. Set the flue gas analyser to read CO₂ and insert the probe into the flue analysis test point (see fig. 1). Restore the electrical supply to the boiler and switch off the boiler. Push INFO and MODE buttons at the same time for 10 seconds to enter the adjusting menu. The display shows "CodE" (see fig. 49). Select the adjusting password by turning the DHW temperature control and confirm it by pushing MODE button.

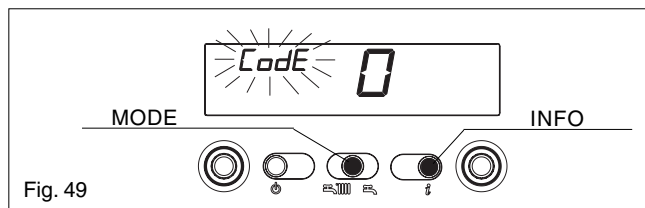

Fig. 49

10.6.1 MAXIMUM SETTING

Select the HH parameter by turning the DHW temperature control and confirm it by pushing MODE button. The boiler starts at the maximum power, the CO₂ reading should be as shown in the table above. If the CO₂ reading is correct, press the MODE button to exit the maximum setting. If the CO₂ reading is incorrect, the maximum gas pressure must be adjusted as follows:

- using a suitable screwdriver, very slowly turn the maximum adjustment screw (see fig. 43) – clockwise to decrease, counter clockwise to increase – until the correct value is displayed on the CO₂ analyser (allow time for the analyser to stabilise).

**IMPORTANT
A GAS SOUNDNESS CHECK MUST BE CARRIED OUT.**

10.6.2 MINIMUM SETTING

Select the LL parameter by turning the DHW temperature control and confirm it by pushing MODE button. The boiler starts at the minimum power, the CO₂ reading should be as shown in the table above. If the CO₂ reading is correct, press the MODE button to exit the minimum setting. If the CO₂ reading is incorrect, the minimum gas pressure must be adjusted as follows:

- using a suitable screwdriver, very slowly turn the minimum adjustment screw (see fig. 43) – clockwise to increase, counter clockwise to decrease – until the correct value is displayed on the CO₂ analyser (allow time for the analyser to stabilise).

- using the procedure detailed in 9.6.1, check that the maximum setting correct value is still being obtained. If not, repeat the above procedure.

BENCHMARK No. | | | | | | |

COLLECTIVE MARK

GAS BOILER COMMISSIONING CHECKLIST

BOILER SERIAL No. _____ NOTIFICATION No. _____

CONTROLS To comply with the Building Regulations, each section must have a tick in one or other of the boxes

TIME & TEMPERATURE CONTROL TO HEATING	ROOM T/STAT & PROGRAMMER/TIMER <input type="checkbox"/>	PROGRAMMABLE ROOMSTAT <input type="checkbox"/>
TIME & TEMPERATURE CONTROL TO HOT WATER	CYLINDER T/STAT & PROGRAMMER/TIMER <input type="checkbox"/>	COMBI BOILER <input type="checkbox"/>
HEATING ZONE VALVES	FITTED <input type="checkbox"/>	NOT REQUIRED <input type="checkbox"/>
HOT WATER ZONE VALVES	FITTED <input type="checkbox"/>	NOT REQUIRED <input type="checkbox"/>
THERMOSTATIC RADIATOR VALVES	FITTED <input type="checkbox"/>	
AUTOMATIC BYPASS TO SYSTEM	FITTED <input type="checkbox"/>	NOT REQUIRED <input type="checkbox"/>

FOR ALL BOILERS CONFIRM THE FOLLOWING

THE SYSTEM HAS BEEN FLUSHED IN ACCORDANCE WITH THE BOILER MANUFACTURER'S INSTRUCTIONS?

THE SYSTEM CLEANER USED _____

THE INHIBITOR USED _____

FOR THE CENTRAL HEATING MODE, MEASURE & RECORD

GAS RATE _____ 3/hr _____ 3/hr

BURNER OPERATING PRESSURE (IF APPLICABLE) N/A _____

CENTRAL HEATING FLOW TEMPERATURE _____ °C

CENTRAL HEATING RETURN TEMPERATURE _____ °C

FOR COMBINATION BOILERS ONLY

HAS A WATER SCALE REDUCER BEEN FITTED? YES NO

WHAT TYPE OF SCALE REDUCER HAS BEEN FITTED? _____

FOR THE DOMESTIC HOT WATER MODE, MEASURE & RECORD

GAS RATE _____ 3/hr _____ 3/hr

MAXIMUM BURNER OPERATING PRESSURE (IF APPLICABLE) N/A _____ mbar

COLD WATER INLET TEMPERATURE _____ °C

HOT WATER OUTLET TEMPERATURE _____ °C

WATER FLOW RATE _____ lts/min

FOR CONDENSING BOILERS ONLY CONFIRM THE FOLLOWING

THE CONDENSATE DRAIN HAS BEEN INSTALLED IN ACCORDANCE WITH THE MANUFACTURER'S INSTRUCTIONS? YES

FOR ALL INSTALLATIONS CONFIRM THE FOLLOWING

THE HEATING AND HOT WATER SYSTEM COMPLIES WITH CURRENT BUILDING REGULATIONS

THE APPLIANCE AND ASSOCIATED EQUIPMENT HAS BEEN INSTALLED AND COMMISSIONED IN ACCORDANCE WITH THE MANUFACTURER'S INSTRUCTIONS

IF REQUIRED BY THE MANUFACTURER, HAVE YOU RECORDED A CO/CO₂ RATIO READING? N/A YES _____ CO/CO₂ RATIO

THE OPERATION OF THE APPLIANCE AND SYSTEM CONTROLS HAVE BEEN DEMONSTRATED TO THE CUSTOMER

THE MANUFACTURER'S LITERATURE HAS BEEN LEFT WITH THE CUSTOMER

COMMISSIONING ENG'S NAME PRINT _____ CORGI ID No. _____

SIGN _____ DATE _____

SERVICE INTERVAL RECORD

It is recommended that your heating system is serviced regularly and that you complete the appropriate Service Interval Record Below.

Service Provider. Before completing the appropriate Service Interval Record below, please ensure you have carried out the service as described in the boiler manufacturer's instructions. Always use the manufacturer's specified spare part when replacing all controls

SERVICE 1 DATE _____
ENGINEER NAME _____
COMPANY NAME _____
TEL No. _____
CORGI ID CARD SERIAL No. _____
COMMENTS _____
SIGNATURE _____

SERVICE 2 DATE _____
ENGINEER NAME _____
COMPANY NAME _____
TEL No. _____
CORGI ID CARD SERIAL No. _____
COMMENTS _____
SIGNATURE _____

SERVICE 3 DATE _____
ENGINEER NAME _____
COMPANY NAME _____
TEL No. _____
CORGI ID CARD SERIAL No. _____
COMMENTS _____
SIGNATURE _____

SERVICE 4 DATE _____
ENGINEER NAME _____
COMPANY NAME _____
TEL No. _____
CORGI ID CARD SERIAL No. _____
COMMENTS _____
SIGNATURE _____

SERVICE 5 DATE _____
ENGINEER NAME _____
COMPANY NAME _____
TEL No. _____
CORGI ID CARD SERIAL No. _____
COMMENTS _____
SIGNATURE _____

SERVICE 6 DATE _____
ENGINEER NAME _____
COMPANY NAME _____
TEL No. _____
CORGI ID CARD SERIAL No. _____
COMMENTS _____
SIGNATURE _____

SERVICE 7 DATE _____
ENGINEER NAME _____
COMPANY NAME _____
TEL No. _____
CORGI ID CARD SERIAL No. _____
COMMENTS _____
SIGNATURE _____

SERVICE 8 DATE _____
ENGINEER NAME _____
COMPANY NAME _____
TEL No. _____
CORGI ID CARD SERIAL No. _____
COMMENTS _____
SIGNATURE _____

SERVICE 9 DATE _____
ENGINEER NAME _____
COMPANY NAME _____
TEL No. _____
CORGI ID CARD SERIAL No. _____
COMMENTS _____
SIGNATURE _____

SERVICE 10 DATE _____
ENGINEER NAME _____
COMPANY NAME _____
TEL No. _____
CORGI ID CARD SERIAL No. _____
COMMENTS _____
SIGNATURE _____



Cod. 10030042 - 10/07 - Ed. 2

Registered address:

Vokèra Ltd
Borderlake House
Unit 7 Riverside Industrial Estate
London Colney
Herts AL2 1HG

enquiries@vokera.co.uk

www.vokera.co.uk
www.vokera.ie

Sales, General Enquires

T 0844 391 099
F 0844 391 0998

Vokèra Ireland
West Court, Callan
Co Kilkenny
T 056 7755057
F 056 7755060

Vokèra Limited reserve the right to change
specification without prior notice
Consumers statutory rights are not affected.

A Riello Group Company.
Company Reg No: 1047779