

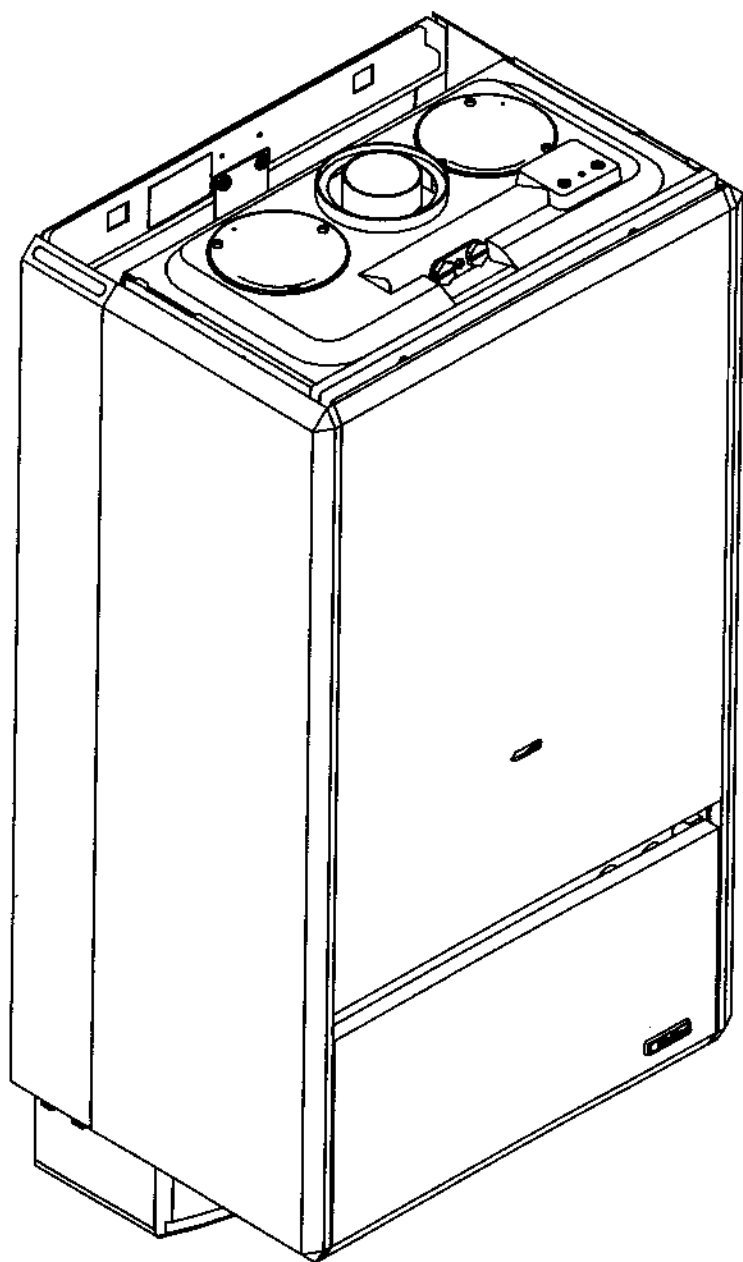

Vokèra

DOMESTIC HEATING APPLIANCES

Dauvele
31 GEN. 2002



EXCELL 80E & 96E

Installation and Servicing Instructions



Tested and Certified
63 AO 0640 (N/G)
63 AQ 0640 (LPG)

British Gas Service Listed
80E G.C. No. 47 094 18
96E G.C. No. 47 094 19

WRc No. 9502032

**HAND THESE
INSTRUCTIONS
TO THE USER**

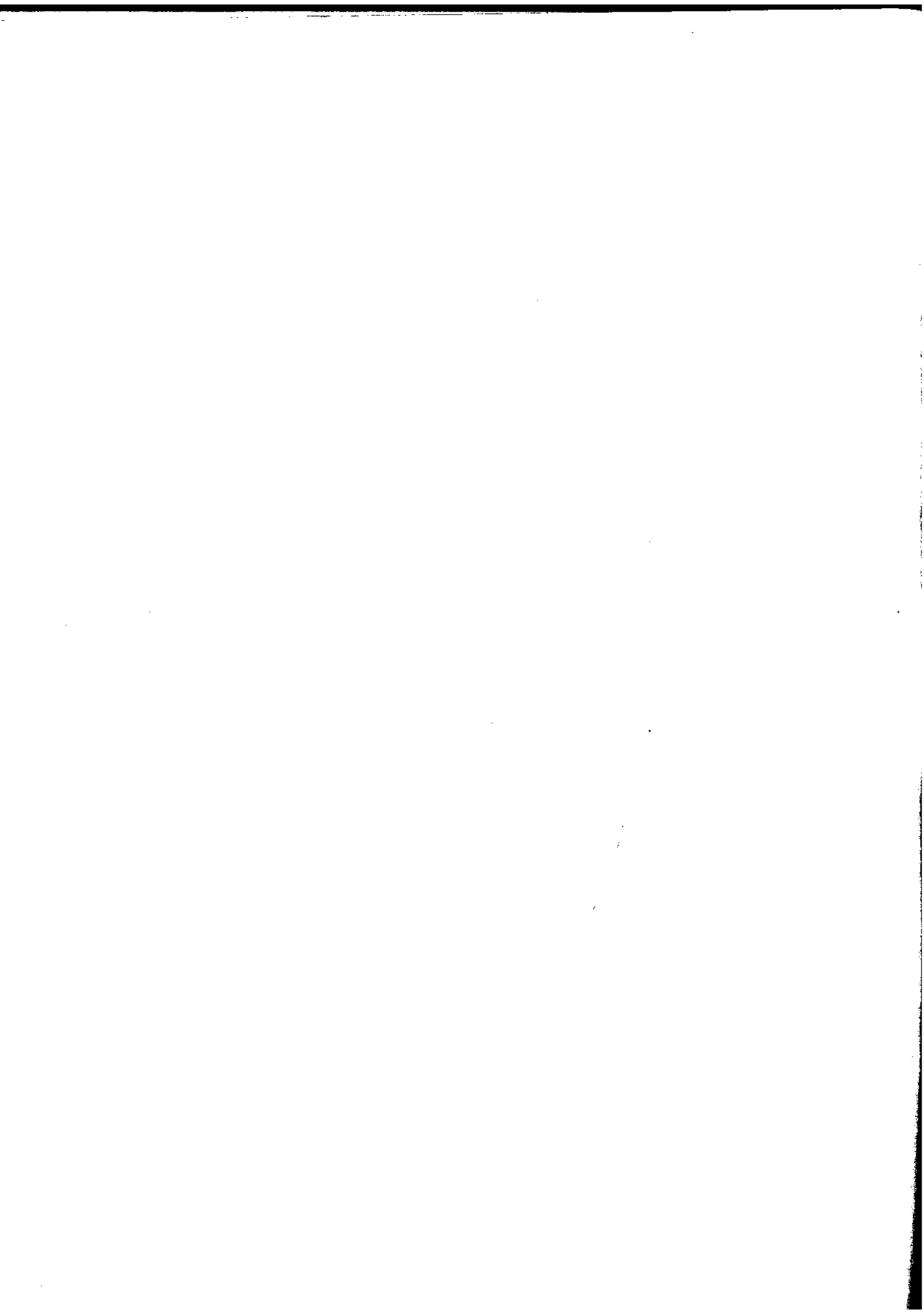

SECTION 1 INTRODUCTION

The Vokera EXCELL 80E & 96E are combined central heating and domestic hot water appliances. By design they incorporate full sequence electronic ignition, circulating pump, expansion vessel, safety valve, temperature gauge, pressure gauge, 3 port diverter valve and self diagnostic L.E.D. display.

They are produced as a room sealed category C1, C3, C6 appliance suitable for wall mounting applications only. They are provided with a fan powered flue outlet with an annular co-axial combustion air intake which can be rotated through 360 degrees. A vertical flue option is available, and they are also suitable for S.E. duct installation.

These appliances are designed for use with a sealed heating system only and are not intended for use on an open vented system.

The provision of stored domestic hot water is possible by the addition of an indirect cylinder with 'S' plan controls.

A range-rating facility is incorporated in the boiler for the central heating system in conjunction with the electronic burner modulation. The domestic hot water (dhw) service utilises a differential water pressure control combined with a 3 port diverter valve to give hot water priority.

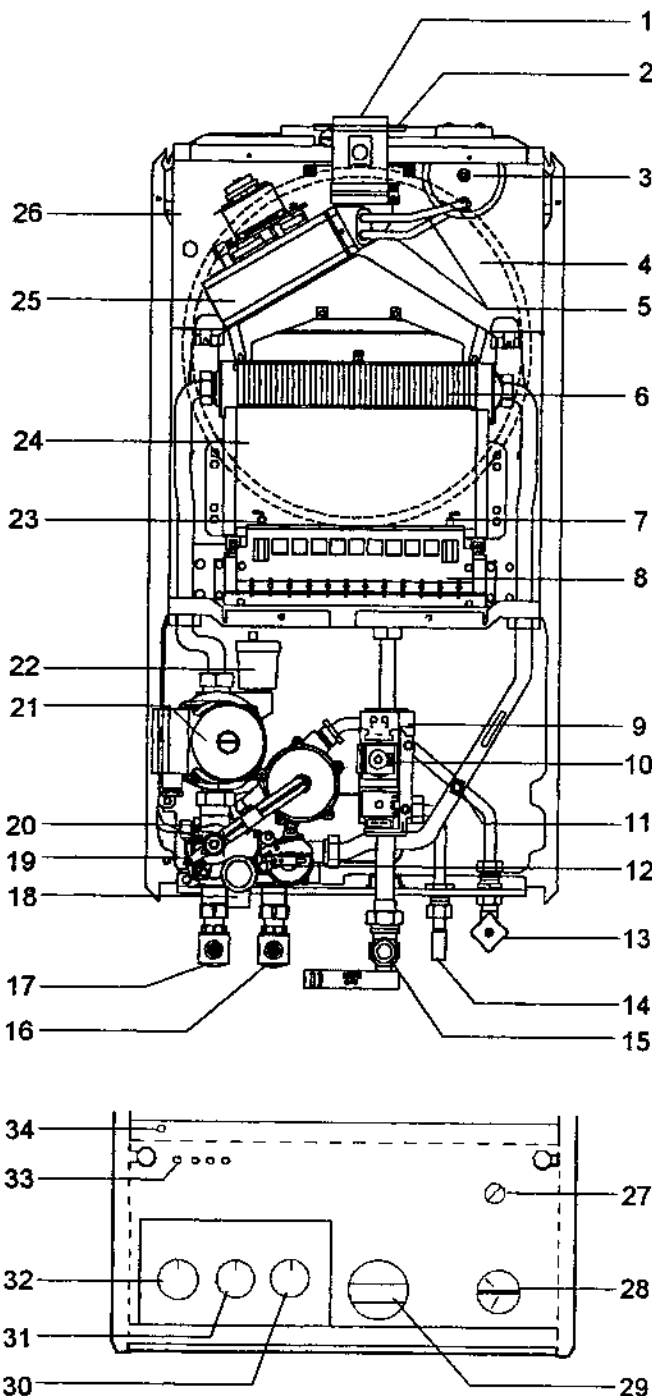
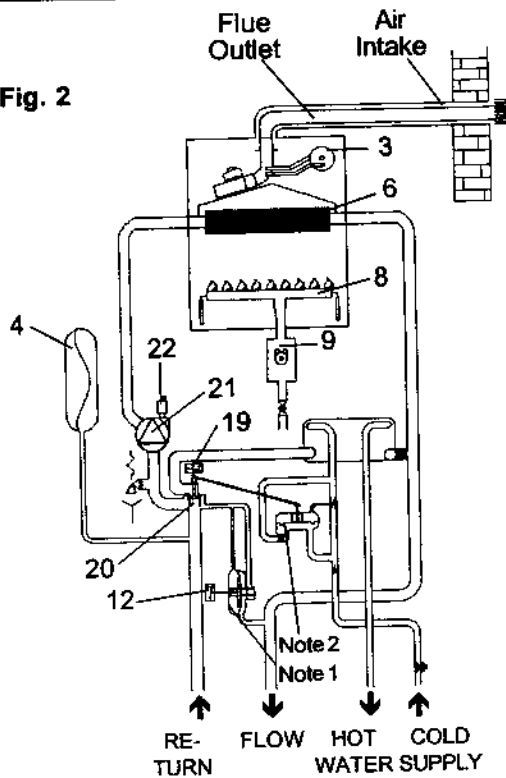

Fig.1 General Layout

- 1 Flue Outlet
- 2 Air Intake & Restrictor Ring
- 3 Pressure Differential Switch
- 4 Expansion Vessel
- 5 Silicone Pressure Tubes
- 6 Main Heat Exchanger
- 7 Flame Sensing Electrode
- 8 Main Burner
- 9 Gas Valve
- 10 Modulator Coil
- 11 Temperature Sensor (Thermistor)
- 12 Flow Switch (Boiler)
- 13 Cold Water Inlet Stopcock
- 14 Hot Water Outlet
- 15 Gas Service Tap
- 16 Central Heating Flow Valve
- 17 Central Heating Return Valve
- 18 Safety Valve
- 19 Domestic Microswitch
- 20 Three Port Diverter Valve
- 21 Pump
- 22 Automatic Air Release Valve
- 23 Spark Electrode
- 24 Combustion Chamber
- 25 Fan
- 26 Air Chamber (with front removed)
- 27 High Limit Thermostat Reset
- 28 Temperature/Pressure Gauge
- 29 Timeclock Aperture (optional)
- 30 Hot Water Temperature Control
- 31 Central Heating Temperature Control
- 32 On/Off and Mode Selector Switch
- 33 Diagnostic L.E.D.'s
- 34 Status L.E.D. (green = normal, red = fault)

Fig. 2



Notes

1. Differential pressure unit. Senses water flow rate through the pump & main heat exchanger and operates the flow switch.(12)
2. Differential pressure unit. Senses domestic hot water flow which operates the single microswitch and fulcrum arm operating the 3 port valve (20).

SECTION 2 DESIGN PRINCIPLES AND OPERATING SEQUENCE

- 2.1 Fig.1 illustrates the general layout of components. Fig.2 illustrates the operating principles described below
- 2.2 **Central Heating Mode**
- 2.2.1 When the various switches and controls impose a demand for heat, the pump is started. The flow of water from the pump operates a flow switch. This in turn energises the electronic ignition circuitry. The fan is started, the gas valve is energised at an intermediate rate and the electronic ignition goes through an ignition attempt.
- 2.2.2 The burner ignition is checked by the electronic circuitry to ensure correct ignition of the burner, once successful and after a delay period of approx. 2 minutes, the electronic control will allow the full rate of gas to flow through the gas valve.
- 2.2.3 As water temperature increases this is sensed by the temperature sensor on the flow pipe which modulates the burner to match the heat output to the heat requirement of the system.
- 2.2.4 Depending on the load, either the water temperature will continue to rise and the burner will continue to modulate down until the minimum setting is reached at which point the burner is switched off, or the water temperature will fall and the burner will return to a higher output to match the demand.
- 2.3 **Domestic Hot Water Mode**
- 2.3.1 The appliance will operate in domestic hot water mode whenever the on/off switch is on regardless of mode selector switch

- 2.3.2 Opening a draw off tap will operate the dhw differential pressure device which in turn operates the 3-port valve (20) and the dhw flow switch.
- The three port valve diverts boiler water to the dhw heat exchanger.
- 2.3.3 The dhw flow switch transfers control of the burner to the dhw temperature control potentiometer (30) which modulates the burner output between high and low flame to maintain an average heat input to suit the dhw output required.
- 2.3.4 An overrun is incorporated in the boiler, in c/h mode the pump overruns until the boiler water cools to approximately 75°C (167°F). In dhw mode only the fan will overrun instead of the pump.
- 2.4 **Safety Devices**
- 2.4.1 In both central heating and hot water modes safe operating is ensured by
- A. Differential pressure units in both primary and dhw circuits which prevent burner operation if water flow rates are too low.
 - B. A high limit thermostat, which interrupts the control circuit shutting off the gas valve. At the same time the fan will still operate.
 - C. A Pressure differential switch in the flue system to check the fans operation before allowing ignition.
- 2.4.2 A safety valve is provided to relieve excess pressure from the primary circuit.

SECTION 3 TECHNICAL DATA

3.1 Units Dimensions and values are given in the preferred SI Units with Imperial units in brackets where applicable.

3.2 Dimensions and Contents

Height 790mm (31.1in) appliance only.
982mm (38.7in) inc. horizontal flue.
Width: 450mm (17.7in)
Depth: 325mm (12.8in)
Weight empty 53kg (117lb)
full 56kg (123lb)
Water content: 3 litres (.66 gals)
for further dimensions see figs 13 - 16

3.3 Connection sizes

Heating flow and return: Nut and olive for 22mm o.d.
Cold water inlet: Nut and olive for 15mm o.d.

Hot water outlet: Nut and tail for 15mm compression or capillary.
Gas Service: Rc 1/2 (1/2in BSP int)
Safety valve outlet: Rc 1/2 (1/2in BSP int)

Flue outlet/Air inlet: nom dia 60/100mm specially supplied with boiler (concentric).
Flue outlet/Air inlet: nom dia 80/80mm specially supplied with boiler (twin).

3.4 Installation Requirements

3.4.1 Clearances (Horizontal or Vertical Flue)

Minimum - above casing 225mm (9in)
Minimum - below casing 150mm (6in)
Minimum - In front 600mm (24in)
Minimum - At sides 12mm (1/2in) from casing)

3.4.2 Maximum heating system contents approx. 76.4 litres (16.8 gals) Acceptance capacity of expansion vessel 8 litres (1.8 gals).

3.4.3 Means of filling sealed system: To accord with BS and/or local Water Authority requirements.

3.4.4 The standard concentric horizontal flue duct allows a maximum length of duct as follows:
Rear flue: 731mm (wall thickness)
Side flue: 890mm (to centre line of boiler).

Using extension tubes the flue may be extended to the following lengths:

Concentric

80E 4.5 metres max. (horizontal)
96E 3.4 metres max. (horizontal)
80E 5.25 metres max. (vertical)
96E 4.4 metres max. (vertical)

Twin

80E & 96E 15/15 metres max. (horizontal)
80E & 96E 15/15 metres max. (vertical)
concentric termination.

The reduction in flue length for each bend used is listed opposite.

CONCENTRIC FLUE:

BEND	REDUCTION IN FLUE LENGTH FOR EACH BEND
90°	850 mm
45°	425 mm
OFFSET	850 mm

TWIN FLUE:

BEND	REDUCTION IN FLUE LENGTH FOR EACH BEND
90°	850 mm
45°	850 mm

3.5 Electrical Details

Mains supply 230v ~ 50Hz Fused 3A
Internal fuse rating F2A
Power consumption: 200w.

3.6 Performance and Limitations 80E

Max. input 26.3 kW (89,735 Btu/h)(net)
Min. input 10.7 kW (36,508 Btu/h)(net)
Max. input 29.2 kW (99,630 Btu/h)(gross)
Min. input 11.9 kW (40,602 Btu/h)(gross)

Max. output 23.7 kW (80,864 Btu/h)
Min. output 8.9 kW (30,366 Btu/h)

Central Heating output range

Max. 23.7 kW (80,864 Btu/h)
Min. 8.9 kW (30,366 Btu/h)

3.7 Performance and Limitations 96E

Max. input 31.0 kW (105,772 Btu/h)(net)
Min. input 10.5 kW (35,826 Btu/h)(net)
Max. input 34.4 kW (117,372 Btu/h)(gross)
Min. input 11.6 kW (39,579 Btu/h)(gross)

Max. output 28.0 kW (95,536 Btu/h)
Min. output 8.9 kW (30,366 Btu/h)

Central Heating output range

Max. 28.0 kW (95,536 Btu/h)
Min. 8.9 kW (30,366 Btu/h)

3.8

Designed temp rise 20°C
Max. flow temperature 85°C

Fig.22 shows the relation between burner pressure and input/output (N/G).

NOTE: Use gross input values when gas rating the appliance (N/G).

3.8.1

L.P.G. instructions are to be found on pages 54 & 55.

3.9 Nominal hot water production

TEMPERATURE RISE °C	FLOW RATE LITRES/MIN.	
	80E	96E
35	9.5	11.4
30	11.1	13.3

3.10 Central Heating Pump Duty

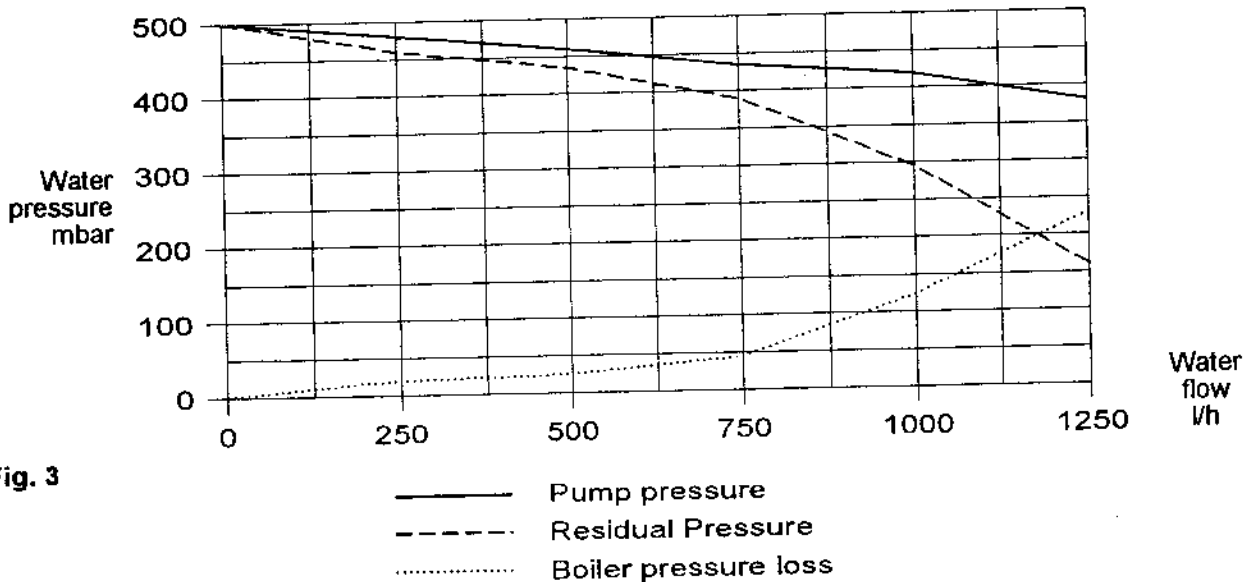

Fig. 3

Working Pressures

Maximum 1.5bar/15m.wg/50ft wg
 Minimum
 Safety valve setting

Heating System

6.0bar/90psig
 0.5bar/5m.wg/16ft wg
 3bar/30m/102ft

Hot Water System

0.6bar/7psig

Flow Rates

Min. water flow (dhw) 2.8 litres/min (0.6 gal/min)
 Min. central heating flow rate through appliance 350 litres/h (1.28 gal/min).

3.11 Gas Rates (N/G)

	80E	96E
Min. Gas Rate	1.13 m3/h 39.9 ft3/h	1.20 m3/h 42.4 ft3/h
Max. Gas Rate	2.69 m3/h 95.0 ft3/h	3.24 m3/h 114.5 ft3/h

3.12 Burner Details (N/G)

	80E	96E
Main Burner	Polidoro NP12	Polidoro NP14
Main Burner Injectors	12 x 1.30	14 x 1.30
Burner Pressure Max. Rate	11.2 mbar	11.0 mbar
Burner Pressure Min. Rate C/H & DHW	1.7 mbar	1.3 mbar

Gas Control Valve: Basic Honeywell VR4605AA 1003 1 220/240v This unit is modified.

The modification comprises a coil carried by the main burner regulation screw. For full flame a voltage of approx. 12.5v dc is applied to the coil. For central heating max. rate the max. voltage to the coil is restricted by an on site adjustment of a potentiometer.

SECTION 4 GENERAL REQUIREMENTS

4.0 General Requirements

This appliance must be installed by a competent person in accordance with the Gas Safety (Installation & Use) Regulations 1996.

4.1 Related Documents

The installation of this boiler must be in accordance with the relevant requirements of the Gas Safety (Installation & Use) Regulations 1984 the Local Building Regulations, the current I.E.E. Wiring Regulations, the by-laws of the local water undertaking, and in Scotland, in accordance with the Building Standards (Scotland) Regulation. In Ireland the local building regulations (IE).

It should be in accordance also with any relevant requirements of the local gas region and local authority and the relevant recommendations of the following British Standard Codes of Practice:

BS 6891		1988	Low pressure installation pipes Boilers of rated input not exceeding 60kW.
BS 6798		1987	
BS 5449	Part 1	1990	Forced circulation hot water systems Installation of gas hot water supplies for domestic purposes (2nd family gases).
BS 5546		1990	
BS 5440	Part 1	1990	Flues

4.2 Location of Appliance

The combination boiler may be installed in any room or internal space, although particular attention is drawn to the requirements of the current I.E.E. Wiring Regulations, and in Scotland, the electrical provisions of the Building Regulations applicable in Scotland, with respect to the installation of the combination boiler in a room or internal space containing a bath or shower.

Where a room-sealed appliance is installed in a room containing a bath or shower, any electrical switch or appliance control, utilising mains electricity, should be located in such a position that it cannot be touched by a person using the bath or shower.

The location chosen for the boiler must permit the provision of a satisfactory flue and termination. The location must also permit an adequate air supply for combustion purposes and an adequate space for servicing and air circulation around the boiler.

Where the installation of the boiler will be in an unusual location special procedures may be necessary and BS 6798:1987 gives detailed guidance on this aspect.

A compartment used to enclose the boiler must be designed and constructed specifically for this purpose. An existing cupboard or compartment may be used provided that it is modified for this purpose.

Details of essential features of cupboard/compartment design including airing cupboard installations are given in BS 6798:1987. This appliance is not suitable for external installation.

4.3 Gas Supply

A gas meter is connected to the service pipe by the local gas region or a local gas region contractor.

An existing meter should be checked, preferably by the gas region to ensure that the meter is adequate to deal with the rate of gas supply required for all appliances it serves.

Installation pipes should be fitted in accordance with BS 6891:1988.

Pipework from the meter to the boiler must be of adequate size. Pipes of a smaller size than the boiler inlet connection should not be used.

The complete installation must be tested for soundness as described in the above code.

N.B. If the gas supply for the boiler serves other appliances ensure that an adequate supply is available both to the boiler and the other appliance when they are in use at the same time.

4.4 Flue System

The terminal should be located where dispersal of combustion products is not impeded and with due regard for the damage or discolouration that might occur to building products in the vicinity (see fig 4).

In cold and/or humid weather water vapour may condense on leaving the flue terminal. The effect of such 'steaming' must be considered.

For protection of combustibles, refer to BS 5440:1 where the terminal is less than 2m (6.6ft) above a pavement or platform to which people have access (including any balcony or flat roof the terminal must be protected by a guard of durable material.

A suitable guard is available from G.R.Claudio (Vokera) Ltd. Part No 018, G.C. No. 301 106

This guard must be fitted centrally over the terminal. Mark the positions of the fixings, drill the wall and secure using wall plugs and 3 of 1½" No.8 plated screws.

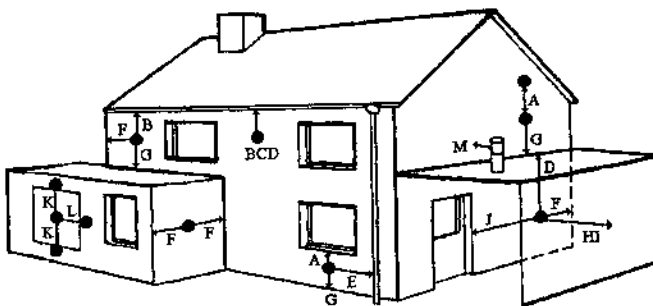

Fig. 4

Terminal position for fan assisted boiler
(minimum distance)

	mm
A - Directly below an open window or other opening (e.g. air brick)	300
B - Below gutters, soil pipes or drain pipes	25
C - Below eaves	25
D - Below balconies or car port roof	25
E - From vertical drain pipes and soil pipes	75
F - From internal or external corners	25
G - Above ground or below balcony level	300
H - From a surface facing a terminal	600
I - From a terminal facing a terminal	1200
J - From an opening in the car port (e.g. door window) into dwelling.	1200
K - Vertically from a terminal on the same wall	1500
L - Horizontally from a terminal on the same wall	300
M - Horizontally from a vertical terminal to a wall	300

NOTE: The flue must be terminated in a place not likely to cause a nuisance.

4.5 Air Supply

The following notes are intended for general guidance.

The roomsealed fan flued boiler does not require a permanent air vent for combustion air supply.

Where installed in a cupboard or compartment ventilation is not required.

4.6

Water Circulation (Central Heating)

Detailed recommendations are given in BS 6798:1987 and BS 5449:1:1990 (for smallbore and microbore central heating systems).

4.6.1

The following notes are given for general guidance.

4.6.2

Pipework

Copper tubing to BS 2871:1:1971 is recommended for water pipe. Jointing should be either by capillary soldered or with compression fittings.

Where possible, pipes should have a gradient to ensure air is carried naturally to air release points and water flows naturally to drain taps.

It should be ensured as far as possible that the appliance heat exchanger is not a natural collecting point for air.

Except where providing useful heat, pipes should be insulated to prevent heat loss and to avoid freezing. Particular attention should be paid to pipes passing through ventilated spaces in roofs and under floors.

4.6.3

By-Pass

An automatic by-pass is incorporated in the boiler and systems should be designed to ensure that with only one radiator turned on a flow rate of at least 350 litres/hour (1.28 gals/min) is achieved through the boiler see cl. 6.9.4

4.6.4

System Design

Figs 5 & 6 illustrate typical layouts.

4.6.5

Draining Taps

These must be located in accessible positions to permit the draining of the whole system. The taps must be at least 15mm nominal size and manufactured in accordance with BS 2879:1980.

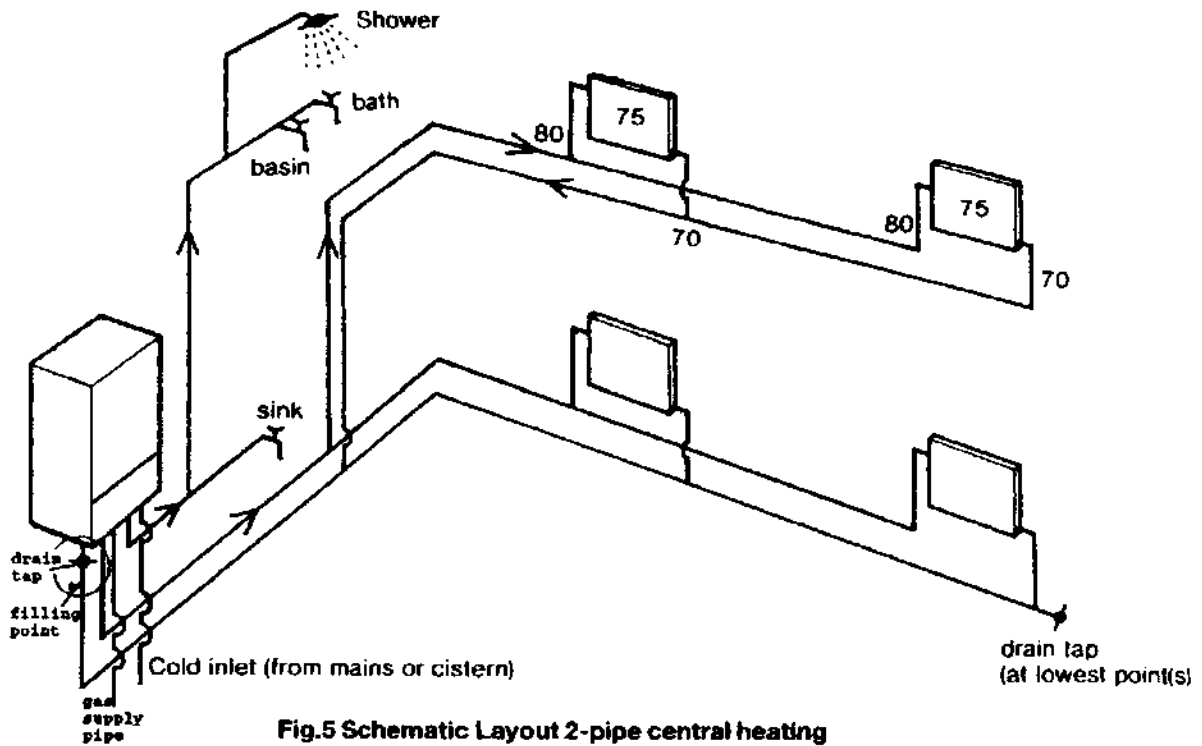

Fig.5 Schematic Layout 2-pipe central heating

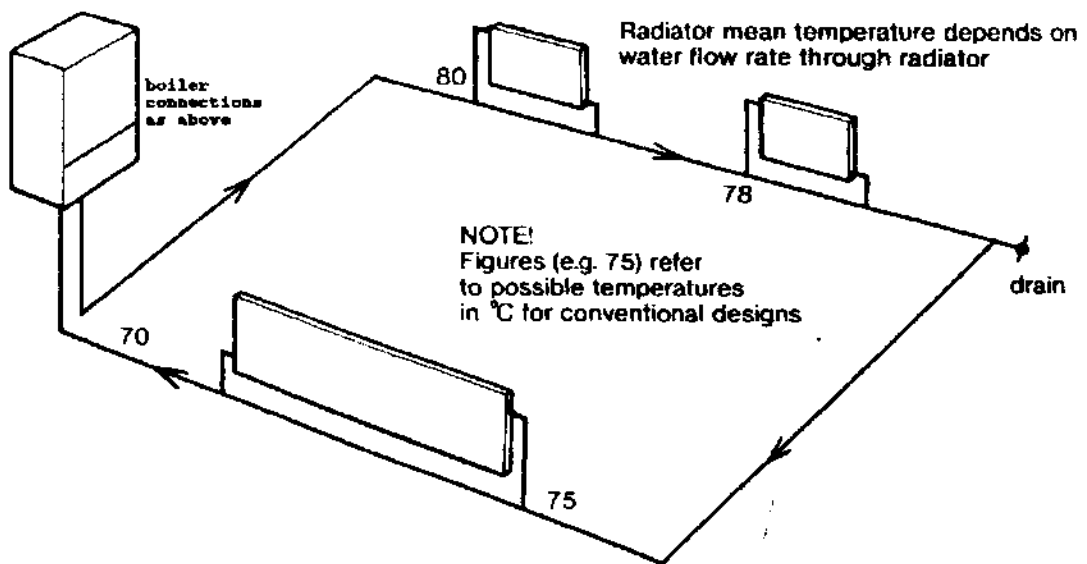

Fig.6 Schematic single pipe central heating

Salient features of each system

2 Pipe

- Radiators connected in parallel
- Water flow to each is directly affected by pump
- Shutting off radiators affects total flow in system
- Radiators have approx. same mean temperature
- Low flow rate affects all radiators equally

1 Pipe

- Each radiator is on individual circuit off main pipe
- Water flow not directly affected by pump.
- Flow in each radiator depends on thermosyphon + pressure differential between connection to main circuit.
- Shutting off individual radiators hardly affects total flow in system.
- Radiator mean temperature progressively drops around systems.
- Low flow rate seriously affects last radiators on circuit.

N.B. Vokera Ltd recommend a 2-pipe system. Single pipe systems are more liable to be troublesome unless carefully designed and installed.

4.6.6 Air Release Points

These must be fitted at all high points where air will naturally collect, and must be sited to facilitate complete filling of the system.

- 4.6.7 The appliance has an integral sealed expansion vessel to accommodate the increase of water volume when the system is heated. It can accept up to 8 litres (1.8gals) of expansion water. If the appliance is connected to a system with an unusually high water content. Calculate the total expansion and add additional sealed expansion capacity as appropriate.

In general, modern systems will present no problem.

4.6.8 Filling Point

A method for initially filling the system and replacing water lost during servicing must be provided, and it must comply with local water authority regulations.

A method is shown in fig. 7 using the Vokera filling loop which is acceptable in most areas. In the event that this method is not suitable in a particular area, contact the local authority for preferred methods.

N.B. The installer should ensure that no leaks exist as frequent filling of the system could cause premature scaling of the main heat exchanger.

4.7 Electrical Supply

The appliance is supplied for operation on 230V ~ 50Hz electricity supply. It should be protected with a 3-amp fuse.

THIS APPLIANCE MUST BE EARTHED.

The method of connection to the mains electricity must allow complete isolation from the supply.

The preferred method is by using a fused double pole switch with a contact separation of at least 3mm.

The switch must supply ONLY the appliance and immediate electrical control circuits (e.g. programmer/room thermostat)

Alternatively, use an unswitched shuttered socket outlet with a fused 3-pin plug both complying with BS 1363.

4.8 Showers

If a shower control is to be supplied from the combination unit it should be of the type which incorporates a thermostatic control and by design is suitable for use with a combination boiler.

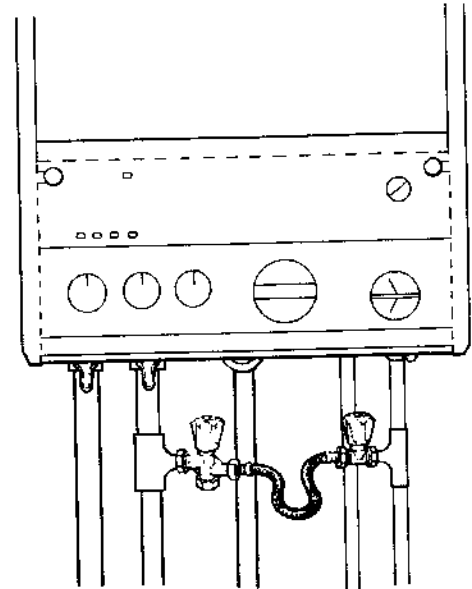

Fig. 7

Fig. 8

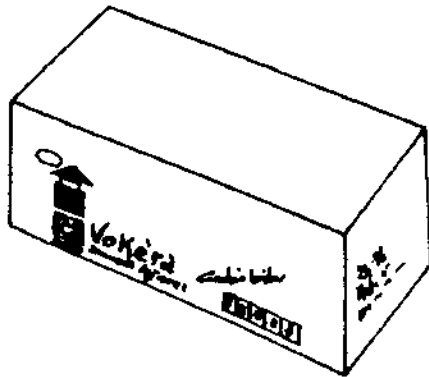

Fig. 9

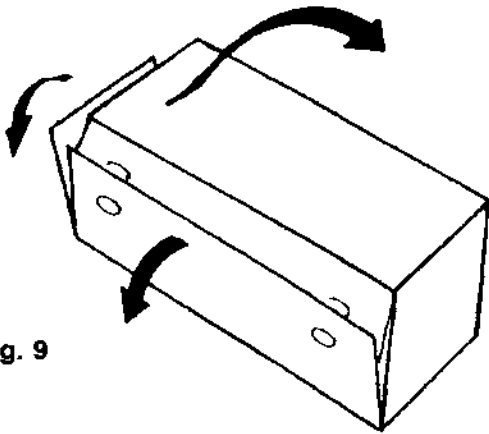

Fig. 10

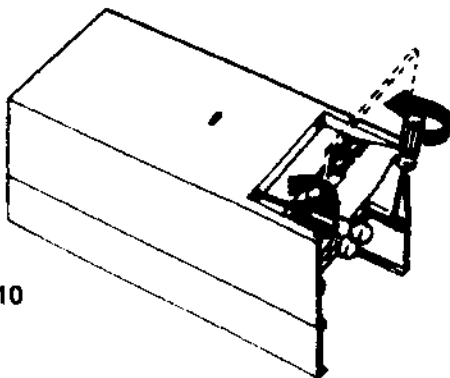
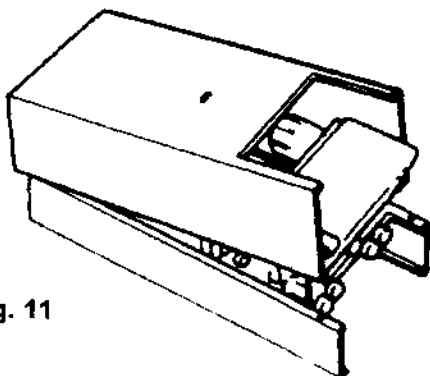

Fig. 11



5.1 Delivery (fig. 8)

The appliance is delivered in a heavy duty cardboard carton.

Lay the carton on the floor with the writing the correct way up.

5.2 Unpacking (fig.9)

Pull both sides of the carton open. Do not use a knife. Unfold the rest of the carton from around the appliance.

Lay the appliance with the black frame on the floor. Remove the two polystyrene blocks one at the top and the other at the base of the appliance.

Remove the hanging bracket from the top polystyrene block and the box containing the fixing kit from the lower polystyrene block.

The fixing kit contains

- 1 - Wall bracket
- 1 - Fittings pack containing:
 - Central heating valves (2)
 - Gas service tap (1)
 - Cold water stopcock (1)
 - Hot water outlet (1 nut & tail)
 - Various washers
- Flue Kit supplied in separate carton.

5.3 Preparing for Mounting

5.3.1 Remove 4 screws securing the lower part of the casing to the case frame. (Fig. 10)

5.3.2 Slightly lift the casing and slide it gently towards the top of the appliance to disengage the case from the top suspension hooks. (Fig. 11)

5.3.3 Ensure the casing and screws are put to one side in a safe place.

5.3.4 Loosely fit (hand tight) the valves and fittings using the washers supplied (Fig. 12)

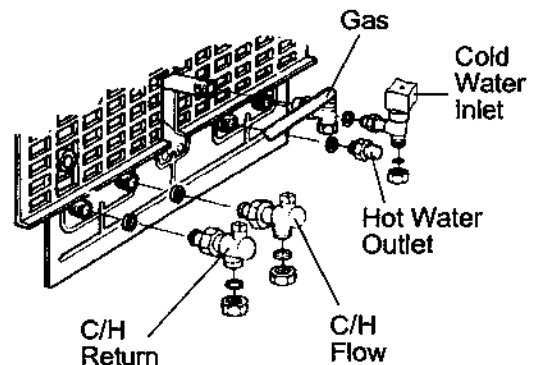

Fig. 12

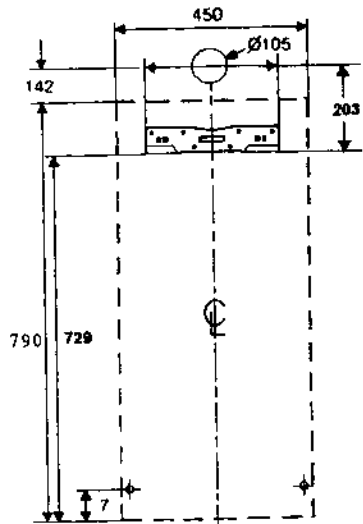

Fig.13

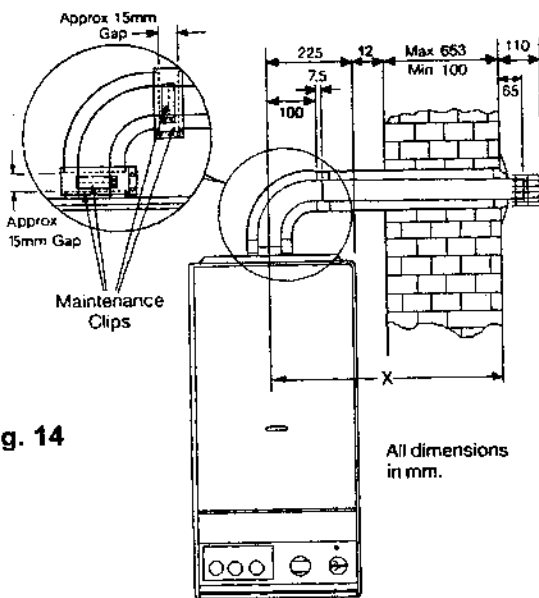
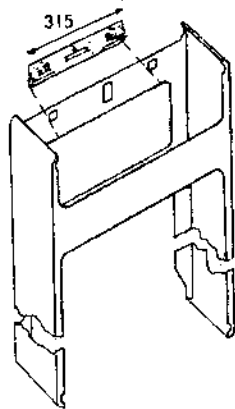
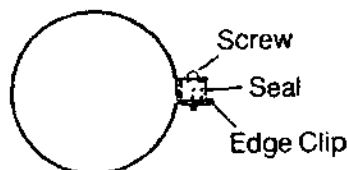

Fig. 14

Fig. 14A



5.4 Mounting the Appliance (Fig. 13)

5.4.1 Place the template on a smooth, vertical incombustible surface and use it to locate the upper bracket, bottom fixing and flue pipe holes. (If the appliance is to be fitted on a wall of combustible material, the wall must be protected by a sheet of fire proof material).

If the appliance is to be fitted in a timber framed building it should be fitted in accordance with the British Gas publication 'Guide for Gas Installations in Timber Framed Housing'. Reference DM2. If in doubt advice must be sought from the local Gas Region of British Gas.

Alternatively, position bracket and holes to dimensions in fig. 13.

5.4.2 Drill and plug the wall for 2 - 2" No. 10 screws for upper bracket and screw the bracket firmly into position using rust proof countersunk screws.

5.4.3 Hang the boiler on the bracket and adjust to final position. Mark the lower fixing holes.

5.4.4 Remove boiler and drill and plug wall for 1½" No. 10 screws.

5.4.5 Drill a 105mm hole through the wall to allow passage of the flue pipe.

Refer to fig. 13 and figs. 14 - 18 for relevant dimensions for locating the hole. Where it is remote from the boiler take special care to ensure hole is at the correct level so that the finished flue is horizontal.

5.5 Fitting the Flue

NOTE: When installing the flue over 1m the flue restrictor ring on the air inlet connection must be removed. (fig. 1 no. 2)

For vertical flue instructions see page 13

For twin flue instructions see page 16

Refer to figures 14 - 18

5.5.1 Assemble the large and small maintenance clips as fig.14A.

5.5.2 The flue outlet elbow may be rotated 360 degrees on its vertical axis. The flue may be extended from this in the horizontal plane.

The standard flue pipe supplied may be used for extension up to 890mm - from outside of wall to centre of the flue elbow. Extension kits (Part No. 026, G.C. No. 370 346) are available to order for total flue lengths of up to 4.5 metres for the 80E and 3.4 metres for the 96E.

5.5.3 Hang the boiler on the bracket. Adjust the boiler sideways to its correct position. Measure carefully from the actual face of the outside wall from the centre of the flue bend. (Dimension X on Figs. 14 & 15).

Locate the small maintenance clip onto the flue elbow fig. 14 and assemble onto the flue outlet on the top of the boiler. Twist the flue bend to the outlet direction required, and tighten the maintenance clip to secure the flue bend in place. Carefully level across to check that the hole through the wall is 1° lower than the flue bend.

5.5.4 The flue kit supplied is suitable for an exact dimension of 890mm.

1 or 2 extension tubes will increase X to 1750mm and 2500mm respectively.

Fig. 15

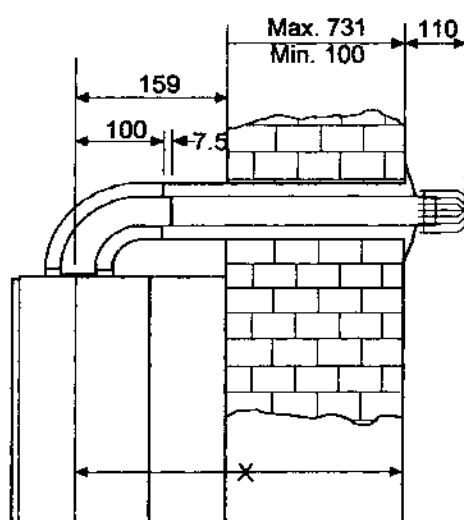
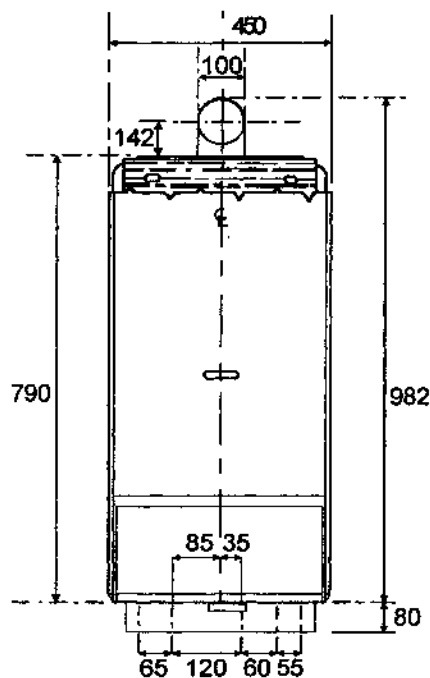

Fig. 16



5.5.5 Where X is less than 890mm, the supplied flue must be shortened as follows:-

Separate the two tubes by removing screw G (fig. 17).

Subtract the measured length from 890mm. The difference is the precise length to be removed from both tubes (890 - X = length to be cut off from the plain ends.)

Example

X is measured as 630mm

Amount to be cut off both tubes is:

$890 - 630 = 260$.

5.5.6 Where X is more than 890mm an extension kit (or kits) is needed. The standard uncut lengths with extension(s) is as follows:-

Always cut the extension tubes, not the standard tube.

1. Measure X.

2a. If using 1 extension piece, cut (1770-X)mm from the inner flue tube but (1750-X)mm from the outer air tube.

2b. If using 2 extension pieces, cut (2600-X)mm from the inner flue tube but (2560-X)mm from the outer air tube.

Shorten inner and outer tubes of last extension piece.

EXAMPLE X = 1295

Cut $1770 - 1295 = 465$ mm from air tube

Cut $1750 - 1295 = 445$ mm from flue tube

CUT CLEAN AND SQUARE WITH FINE TOOTH SAW AND REMOVE BURRS.

5.5.7 Loosen the small maintenance clip and lift the flue bend off the boiler flue outlet.

5.5.8 Ensure inner and outer terminal tubes are firmly fitted together with screw G fig. 17. Push the terminal tubes through the wall until the face of the outer tube protrudes 18mm from the face of the wall (fig. 17). The terminal grill (D) will then protrude 110mm from the wall face.

5.5.9 If extension pieces are used assemble these using the maintenance clips provided. Always fully butt the joints before securing the clips.

5.5.10 Make sure the entire length of the flue is at a 1° drop away from the appliance and adequately supported. Use at least one bracket for each extension. (Conventional adjustable strap supports, Part No. 03, G.C. No. 301 105, suffice, Vokera stockist can supply if necessary)

5.5.11 Assemble the second small maintenance clip on the end of the inner flue tube.

5.5.12 Refit the flue elbow onto the boiler. Align the flue elbow with the flue pipe and tighten the maintenance clip between the flue elbow and the boiler. Ensure pipe sections butt together.

5.5.13 Draw the flue pipe towards the boiler and tighten the second clip over the joint between the inner flue pipe and the flue elbow.

5.5.14 There must now be a gap of approximately 15mm from the elbow to the end of the outer tube.

5.5.15 Check also that the outer end of the flue projects as indicated in fig. 17 or fig. 17A if installed in a S.E. duct.

5.5.16 Referring to fig. 14 fit the large maintenance clips into position and secure the clip screws.

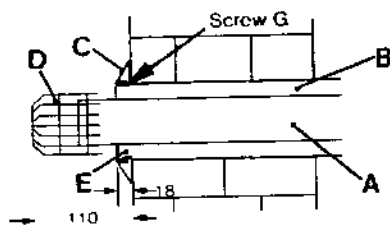

Fig. 17

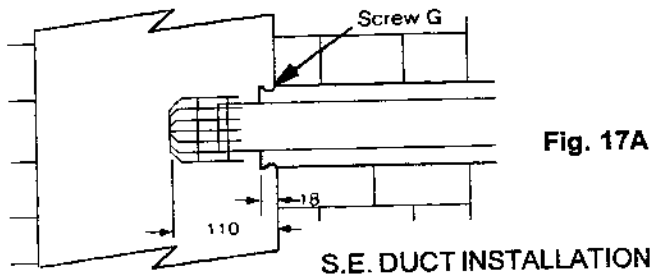

Fig. 17A

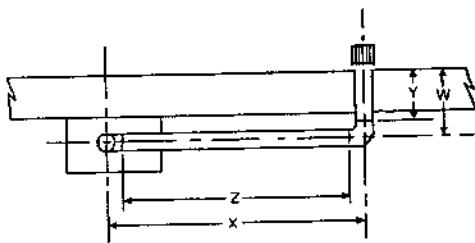

Fig. 18

- 5.5.17 Check adjust and tighten all supports.
- 5.5.18 Seal the peripheral gap around the outer tube with cement or mastic and slip the cosmetic flexible plastic collar (fig. 17) item C) into groove on the pipe. This operation can only be carried out with external access. Seal the internal wall face around the air duct.
- N.B.** Absence of the collar will not affect operation of the appliance but the outer wall must be weather proofed around the air duct.
- 5.5.19 When the flue and appliance are finally positioned screw the lower frame to the wall fig. 13)
- 5.5.20 **Installing optional 90 degree flue bend/s** Part No O2, (G.C. No. 301 104)
- 5.5.21 Assemble the large and small maintenance clips as shown in fig 14A
- 5.5.22 Carry out steps 5.5.2-5.5.3
- 5.5.23 Ensure when siting the flue hole position that the combined distances (Y+Z on fig. 18) between the flue elbow on the boiler to the extra bend and from the face of the outside wall to the extra bend do not exceed the distances given in cl 3.4.4
- 5.5.24 Measure carefully the distance between the centre of the flue bend on the boiler to the centre of the hole through the wall (dimension X fig. 18).

NOTE: Extension kits part No. 026 (G.C. No. 370 346) will be required if the distance measured is greater than 780mm

- 5.5.25 Subtract 230mm from the measured dimension, separate the two tubes and cut the outer tube to this dimension.
- 5.5.26 Cut the inner tube 15mm longer than the outer tube.
- 5.5.27 Referring to fig. 14 assemble a small maintenance clip on the outlet of the boiler flue bend. Push the inner flue tube into clip and tighten clip screws.
- 5.5.28 Slide the outer flue tube into place leaving approx. 15mm between the bend and the flue tube.
- 5.5.29 Referring to fig. 14 fit the large maintenance clip into position and tighten clip screws.
- 5.5.30 Connect the flue tube to the extra bend using the same method ensuring that the bend outlet is in line with the hole through the wall.
- 5.5.31 Ensure that the flue pipe runs parallel to the wall then carefully measure the distance from the outside face of the wall to the centre of the extra bend (dimension W fig. 18).
- 5.5.32 Subtract 97mm from the dimension and cut the outer tube to this length.
- NOTE: The two tubes must be separated by removing screw G fig. 17 before cutting.
- 5.5.33 Ensure that any shortening of the tube is done from the plain end.
- 5.5.34 Reassemble the inner and outer flue tubes and refix screw G.
- 5.5.35 Mark the inner tube 7mm longer than the outer and cut off the inner tube at this point.
- 5.5.36 Remove the large maintenance clip, loosen the small clip and remove the bend.
- 5.5.37 Push the flue tubes through the wall, loosely refit the extra flue bend.
- 5.5.38 Assemble a small maintenance clip onto the inner flue tube, draw the flue tube towards the flue bend until the inner tubes butt. Tighten the screws on the small clip.
- 5.5.39 Referring to fig. 14 fit the large maintenance clip into position and secure clip screws.
- 5.5.40 Check and adjust if necessary so that the outer flue tube protrudes 18mm from the outside face of the wall.
- 5.5.41 Tighten all maintenance clips, make sure that the entire flue has a 1° drop away from the appliance and adequately supported. Use at least one bracket Part No. 03 (G.C. No.301 105) for each extension.

VERTICAL FLUE INSTRUCTIONS

The Vokera Room sealed vertical flue terminal assembly is intended for use where a horizontal flue outlet is not possible or desired. It can be used with either a flat or pitched roof (max pitch 60 Degrees see figs A, B, & C). The vertical flue assembly consists of an annular co-axial combustion air intake, with a specially designed terminal fitted to the top. As supplied the flue assembly is 1050mm long overall and **must not** be cut to shorter dimensions, but may be extended using 850mm long extension tubes Part No. 026 (G.C. No 370 346) or 1700mm long extension tubes Part No. 016 to a maximum overall dimension of **4.4 metres (96E) & 5.25 metres (80E)**. Where a straight flue run is impossible due to an obstruction the flue may be offset using fixed offsets (100mm) Part No. 060 (G.C. No 301 108), 45 Degree bends Part No 059 (G.C. No 301 107) or 90 Degree bends Part No 02 (G.C. No 301 104). If either a fixed offset or a pair of 45 Degree bends are used the maximum permissible flue height is reduced by 850mm. (See 3.4.4). If a pair of 90 Degree bends are used a maximum of one

850mm extension may be used vertically before the first bend & the maximum permissible flue height is reduced by 1700mm.

This assembly must be installed in accordance with BS 5440 part 1.

When installing the flue over 1m the flue restrictor ring on the air inlet connection must be removed. (Fig.1 no.2)

NOTE

The 45° bends have one long and one short limb so may be assembled back to back in three different ways to give offsets of 130mm, 192mm or 254mm (fig. D). Offsets of greater distance may be made by using a straight length between the bends. (fig. B)

VOKERA FLASHING PLATES

Flat - Part No. 061

Angled - Part No. 017 (adjustable 20° - 40°)

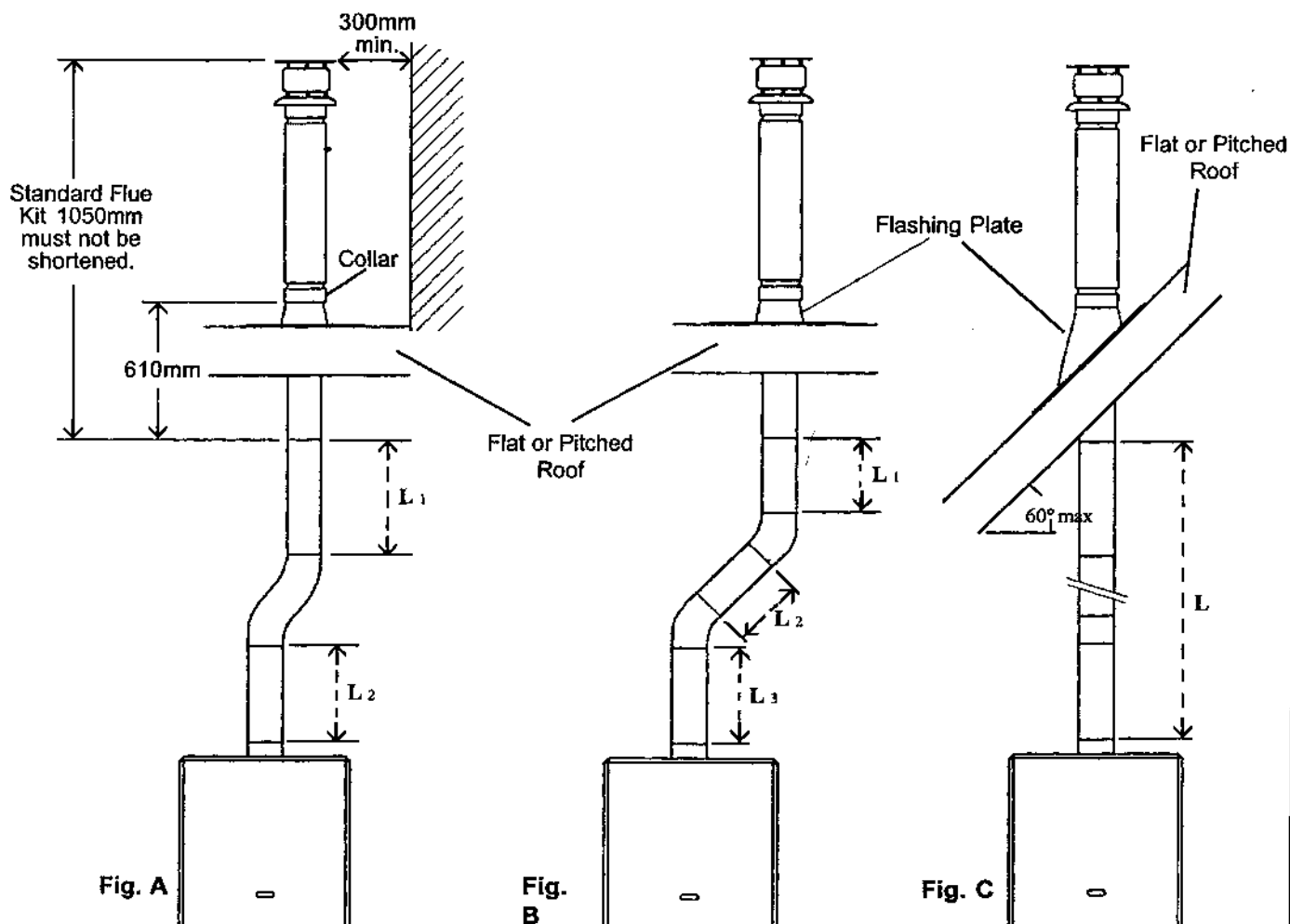

Fig. A

Fig. B

Fig. C

With 1 x Offset
 $L = L_1 + L_2 = 2500\text{mm (max)}$
 $2500+850+1050=4400\text{ (96E)}$

With 2 x 45° Bends (max.)
 $L = L_1 + L_2 + L_3 = 2500\text{mm (max.)}$
 $2500+850+1050=4400\text{ (96E)}$

Straight Flue
 $L = 3350\text{mm max. (96E)}$
 $L = 4200\text{mm max. (80E)}$

Fig. D

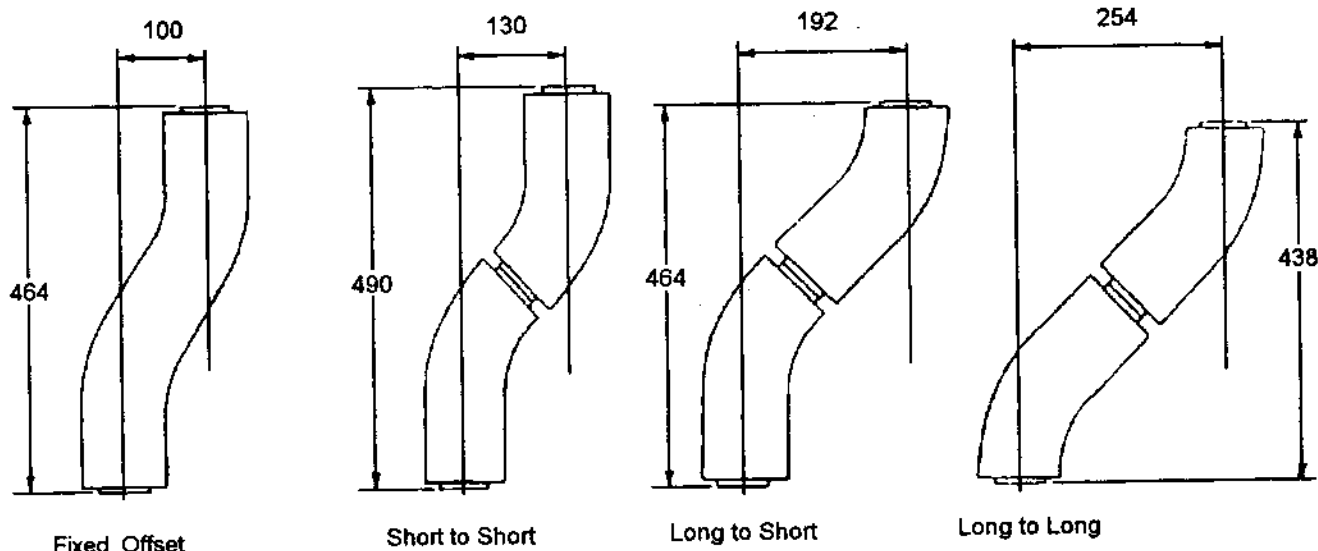

- Proceed with installation as detailed in section 5 of the main installation and servicing Instructions, ignoring all references to the flue installations. It is advisable not to proceed beyond hanging the appliance on the bracket until the flue system is installed.
- NOTE** Where the vertical flue terminal assembly is used without extension, then the dimension W (fig E) is dictated by the particular flashing plate used and is not variable. In this case calculate dimensions W before fixing the appliance mounting bracket. (See steps 5-10).
1. Mark the position of the flue hole in the ceiling and/or roof using the dimension Y in fig E.
 2. Ensure that the maximum permissible flue length is not exceeded and that allowance has been made for any bends or offset used. (figs A,B & C)
 3. Cut a 105mm diameter hole through the ceiling and/or roof.
 4. Fit 100mm(4in) diameter flashing plate to the roof.
- TO CONNECT THE FLUE DIRECTLY TO THE APPLIANCE PROCEED BELOW. (PRIOR TO FIXING APPLIANCE BRACKET) IF USING EXTENSION TUBES/OFFSET/BENDS START AT NUMBER 11.**
5. Insert the vertical flue terminal assembly through the flashing plate from the outside.
 6. Measure W. Then $W+X$ mm (see table) = distance from ceiling for appliance hanging bracket.
 7. Fix the appliance hanging bracket and hang the appliance in accordance with section 5 of the main Installation and Servicing Instructions.
 8. Locate the small maintenance clip onto the appliance flue outlet spigot, (see insert fig.E) draw the flue assembly down towards the appliance until it locates fully into the clip. Tighten clip retaining screws.
 9. There should now be a gap approximately 15mm between the outer sleeve of the air duct and the air duct spigot, (see insert fig.E). Finally fit the large maintenance clip to seal this gap, ensure the screws are fully tightened.
 10. Ensure that the collar on the flue assembly is located over the edge of the flashing plate. (fig.E)
- FLUE CONNECTION USING EXTENSIONS/OFFSETS/BENDS**
- NOTE:** The Offset or 45 ° Bends must not be cut.
11. Insert the vertical flue terminal through the flashing from the outside.
 12. Measure the distance L between the inner flue tubes, or offset/bends (figs A,B & C). Using the list below determine how many extension tubes are required.
 - 1 extension - 850mm
 - 2 extensions - 1700mm
 - 3 extensions - 2550mm(straight flue only)

13. Any shortening of extension tubes must be carried out on the end which does not have the screw retaining the inner and outer tubes together.
14. Remove the screw retaining the inner and outer tubes together.
15. Measure the distance between the inner tubes and cut the inner tube to this length. Using the piece cut off the inner tube mark the same length to be cut from the outer tube, which will leave the inner tube approximately 15mm longer than the outer tube.
16. Replace the screws to retain the inner and outer tube together.
17. Starting at the appliance end assemble the extension duct sections and Offset or Bends (if used) making each joint by butting the inner (flue) tubes and securing with a small maintenance clip, then fitting a large maintenance clip to bridge the gap between the sections of the outer (air) tubes.
18. After making the last joint to the flue terminal assembly ensure that the collar on the outlet tube is still fully located over the edge of the flashing plate to give a waterproof seal. (fig.E) Trim the last section of the extension if necessary.
19. Tighten all maintenance clips, make sure that the entire flue is adequately supported. Use at least one bracket Part No. 03 (G.C. No 301 105) for each extension used.
20. Continue with installation as detailed in these Installation and Servicing Instructions.

Dimensions in mm

X	Y
100	159

Fig. E

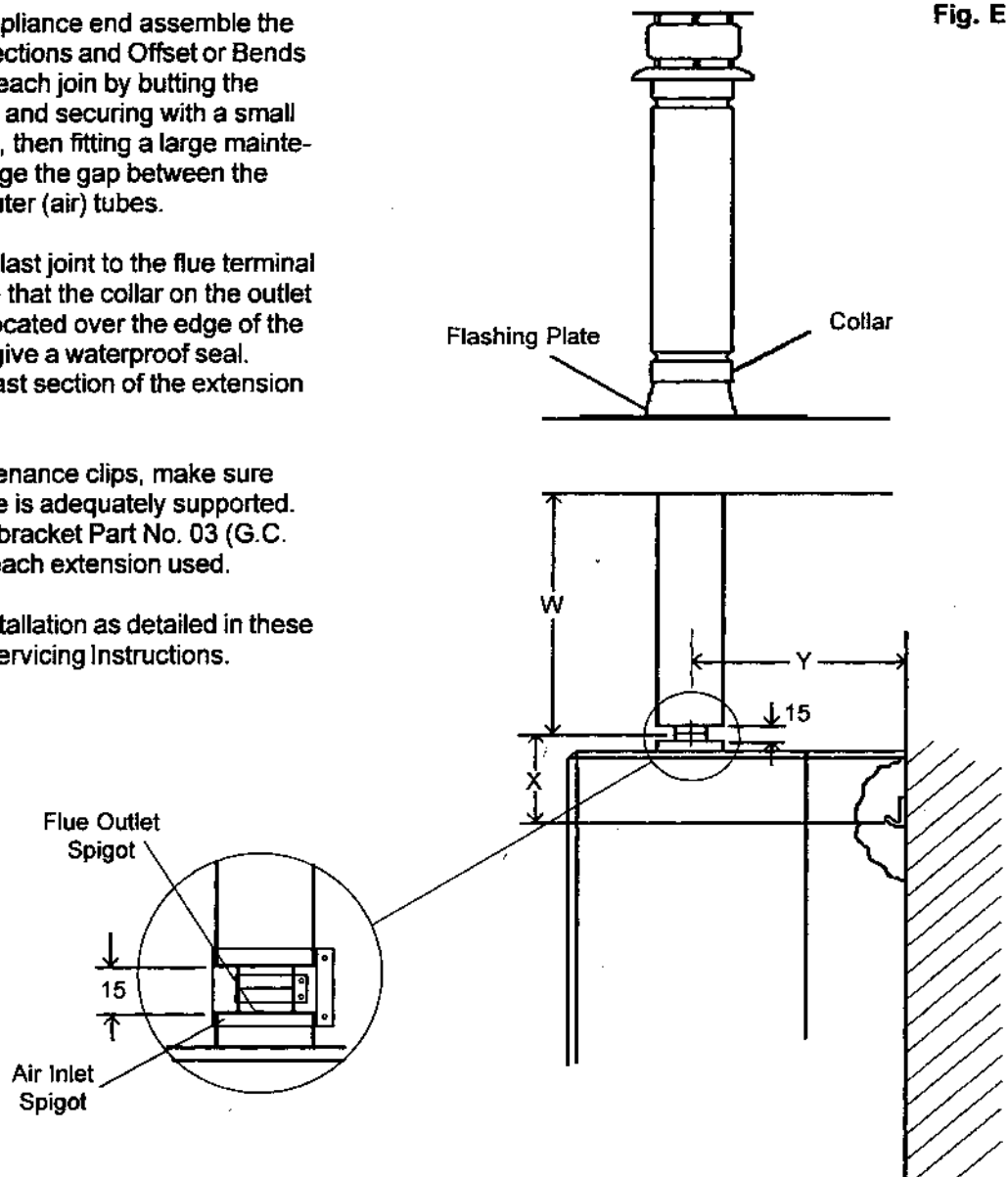

TWIN FLUE INSTALLATION INSTRUCTIONS

The Vokera room sealed twin flue system is intended for use where either the concentric horizontal or vertical flue length would normally be exceeded. It can be used horizontally or vertically, the vertical option being suitable for flat or pitched roofing.

The twin flue must be converted to a concentric flue kit for termination. (Fig. 2)

Maximum flue length:
14m (air inlet) + 14m (exhaust outlet) + 1 x concentric flue outlet terminal (vertical or horizontal)

45° & 90° bends may be added to the flue system, however a reduction must be made to the overall length for each flue accessory used:

Bend	Reduction in flue length for each bend
90°	850mm
45°	850mm

Installation of Twin Flue System

1.0 Assembly of Twin Flue Connection kit.

Kit contains: (fig. 1)

- 1 x Air baffle
- 1 x Exhaust connection manifold
- 1 x Restrictor ring
- 2 x Silicone seals
- 4 x 3.9 x 9.5mm self tapping screws.

- 1.1 Remove the original restrictor ring from the concentric air inlet connection on the boiler.
- 1.2 Insert the new restrictor ring into the exhaust connection manifold. (Only if the combined flue lengths is less than 8m, fig. 1).
- 1.3 Install the exhaust connection manifold onto the existing concentric connection on the appliance by pushing into position.
- 1.4 Insert the internal silicone seal in the recess of the exhaust connection manifold ensuring that it is pushed to the bottom of the recess.
- 1.5 Place the external silicone seal over the shoulder of the exhaust connection manifold.

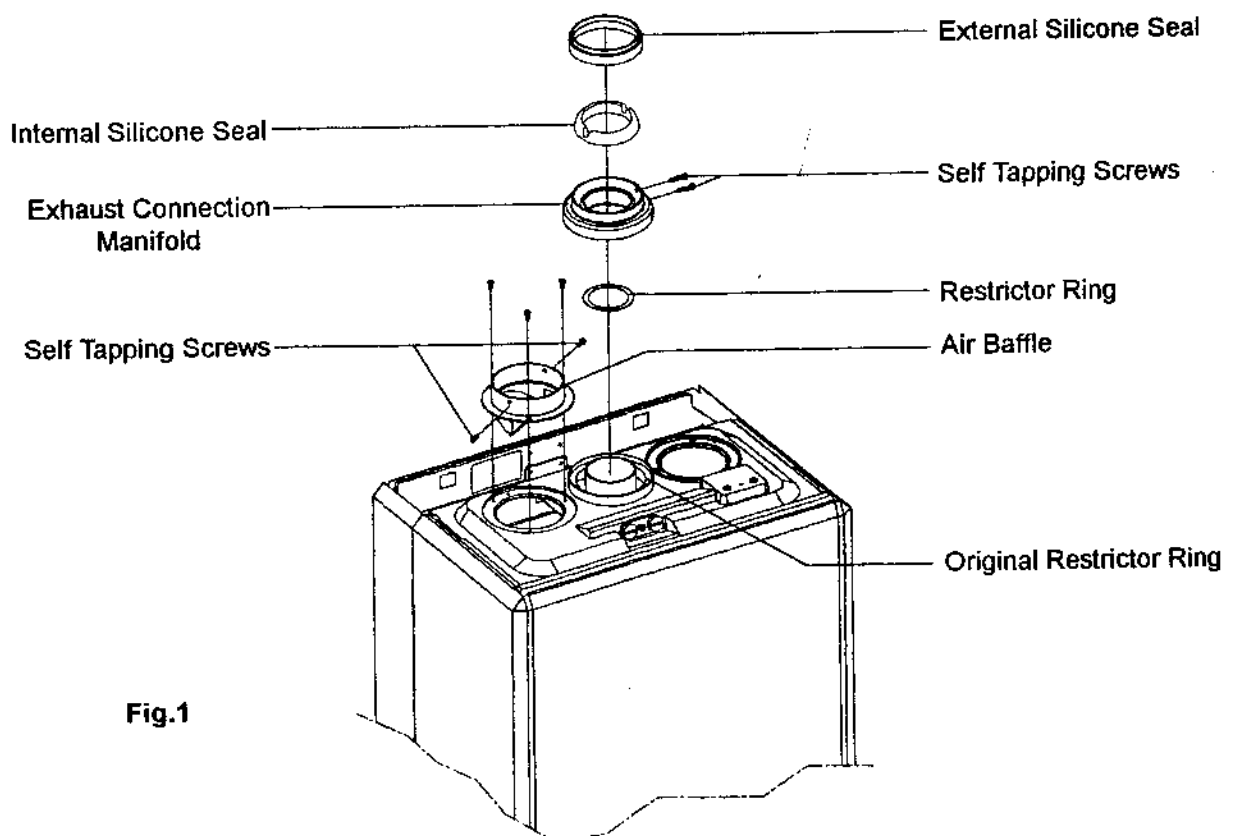

Fig.1

Fig. 2

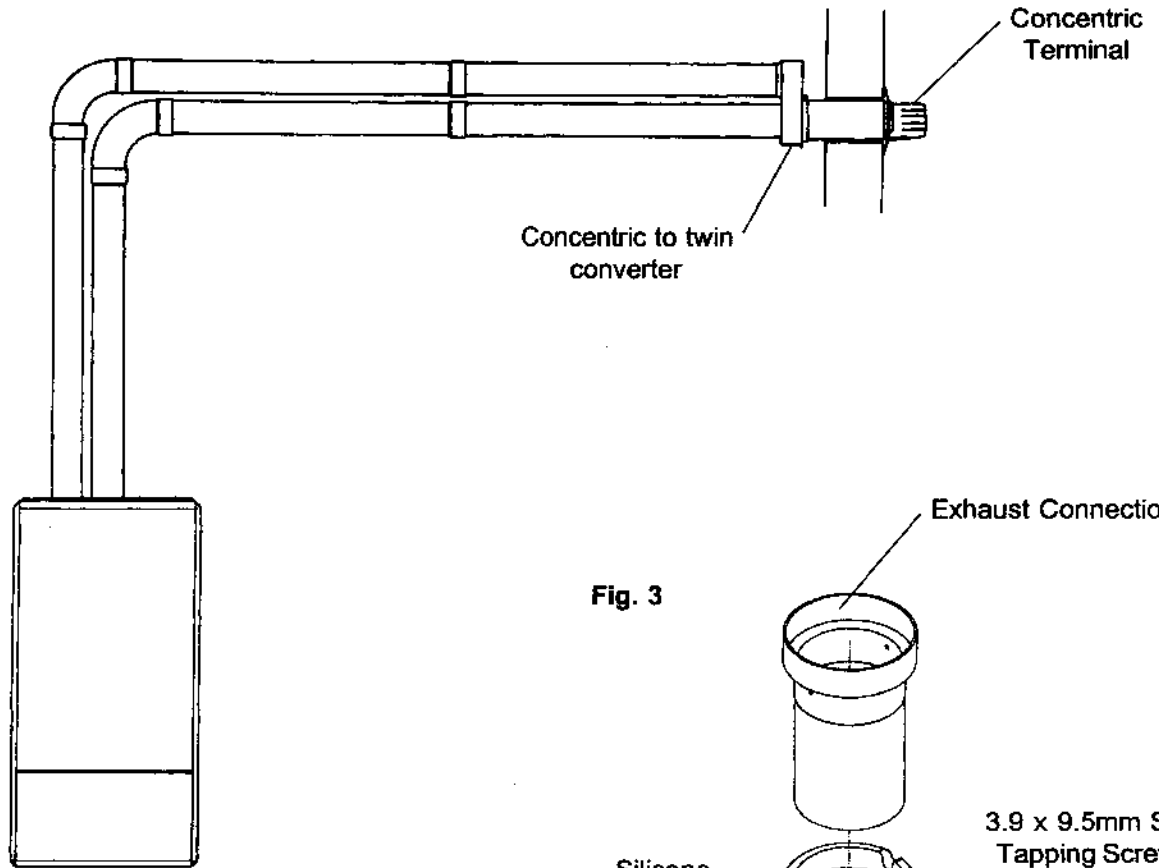

Fig. 3

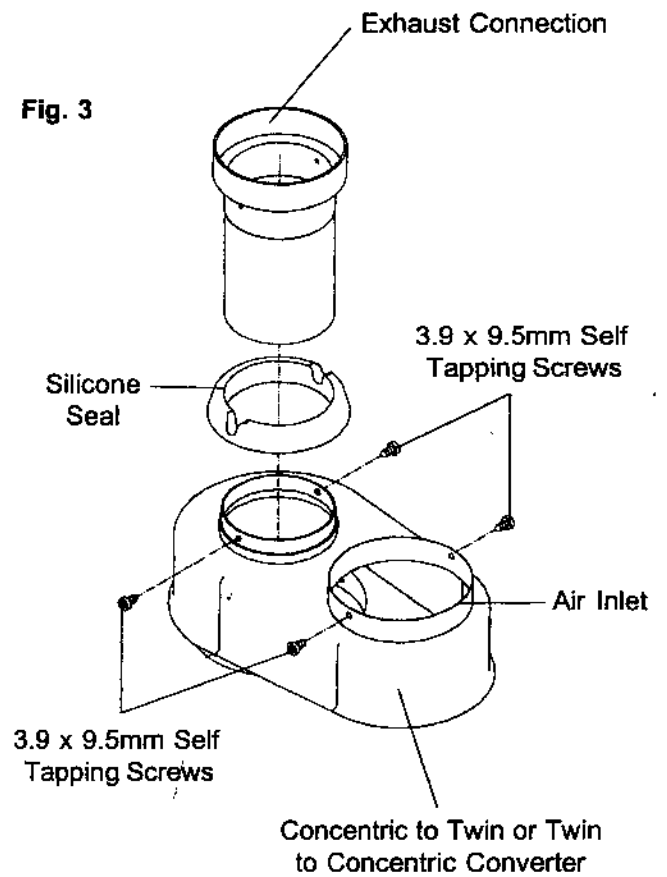
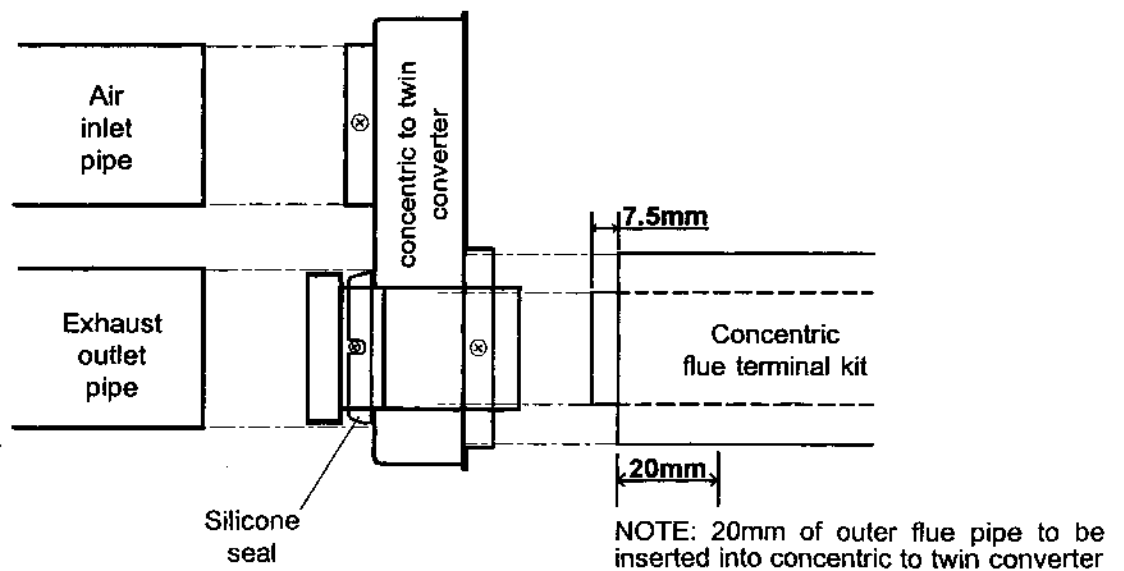

Fig. 4



- 1.6 Depending on flue configuration remove either the left or right hand cover from the top of the combustion chamber, using these screws install the air baffle.
- 1.7 Fit the first bend or extension to the exhaust connection manifold by firmly pushing into position.
- 1.8 Using the two holes in the exhaust connection manifold as a guide, drill 3mm holes and securely fix using the 3.9 x 9.5mm screws provided.
- 1.9 Connect the air inlet pipe to the air baffle in a similar manner to the exhaust pipe (silicone seal not required).
- 1.10 The twin flue pipe extensions and accessories can now be assembled and installed by pushing together. (The plain end of each extension or bend should be pushed approx. 50mm into the female socket of the previous piece).
- 1.11 The swaged end of the last extension piece of both the exhaust outlet & air inlet pipe will now have to be cut off. This is done for connection onto the twin to concentric converter.
- 1.12 Before cutting swaged ends off, ensure that the twin flue pipe is long enough to connect onto the converter & concentric flue terminal. This would be made easier by installing the horizontal/vertical flue terminal & converter before you make the cut.

2.0 Assembly of Twin Flue to Concentric Converter. (Fig. 3 & 4)

Kit contains:

- 1 x Concentric to twin converter
- 1 x Silicone seal
- 1 x Exhaust connection (60 to 80mm)
- 4 x 3.9 x 9.5mm self tapping screws

- 2.1 Position the silicone seal over the lip of the exhaust outlet on the concentric to twin converter (smaller hole), ensuring that the cut out either side of the silicone seal aligns with the two holes on the exhaust outlet.
- 2.2 Slide the exhaust connection through the exhaust outlet on the concentric to twin converter, ensuring that the two holes align with the two holes on the concentric to twin converter (the exhaust connection will protrude through the base of the concentric to twin converter).
- 2.3 Using two 3.9 x 9.5 self tapping screws secure the exhaust connection to the concentric to twin converter.

3.0 Concentric Termination.

- 3.1 Follow the instructions detailed on page 10, figs. 14 & 15 for horizontal or page 13 for vertical flue (termination only).
- 3.2 Depending on the flue installation/wall thickness it may be necessary to cut down the concentric flue kit (horizontal only). If so cut the outer flue tube so it is 50mm proud of the inside wall, then cut the inner flue tube so that it is 7.5mm proud of the outer flue tube.
- 3.3 Push fit the concentric to twin converter onto the concentric flue kit (ensuring that the outer flue tube of the concentric flue kit only pushes into the converter by a maximum of 20mm. (See fig. 4).
- 3.4 Using the holes on the concentric to twin converter as a guide drill 2 x 3mm holes in the air inlet pipe only and securely fix using the 3.9 x 9.5mm screws provided.
- 3.5 Cut the twin flue pipes to allow connection onto the twin to concentric converter.
- 3.6 Push fit the twin flue pipes onto the concentric to twin converter ensuring that the twin exhaust pipe connects to the exhaust connection on the concentric to twin converter. (see fig. 4)
- 3.7 Using the holes in the concentric to twin converter as a guide drill 2 x 3mm holes in the air inlet pipe and fix securely using the 3.9 x 9.5mm screws provided.

4.0 Guidance Notes on Twin Flue Installation.

- 4.1 If the flue is installed horizontally the flue must have a fall of 1° away from the appliance.
- 4.2 Ensure that the entire flue system is adequately supported, use at least one bracket for each extension.
- 4.3 In certain weather conditions condensation may accumulate on the outside of the air inlet pipe. Such conditions must be considered and where necessary insulation of the air inlet pipe may be required.

5.6 Connecting the Gas and Water

- 5.6.1 Figs. 12 and 16 show the locations of the fittings.
- 5.6.2 Do not over tighten nuts and use another spanner to apply counter force to avoid damaging the appliance
- 5.6.3 **Gas Supply**
Connecting the gas supply.
Connect a 15mm gas pipe to the gas service tap and tighten the union nut securing the tap to the appliance.
- 5.6.4 **Central Heating**
Connect the central heating pipework (22mm o.d) to the respective valves, right hand = flow, left hand = return, and tighten the nuts.
- 5.6.5 **Hot Water**
Provide a suitable coupling and connect the hot water draw-off pipe to the 15mm o.d tail. Tighten the nut.

If the hot water system does not include a tap below the hot water outlet connection provide a suitable drain tap to permit draining of the appliance hot water side during servicing.

- 5.6.6 **Cold Water**
Connect a 15mm cold water service pipe to the inlet stopcock of the appliance. Tighten the nut.
If the cold water supply is liable to large pressure fluctuations, some form of flow/pressure regulator should be fitted in the supply pipe.

- 5.6.7 **Safety Valve Discharge**
The safety valve is located beneath the pump. It has a threaded outlet Rc 1/2 (1/2in BSP Int) to permit a discharge pipe to be connected.

When connecting, ensure the discharge pipe does not restrict access to or operation of the central heating valves. The discharge should terminate facing downwards exterior to the building in a position where discharging (possible boiling) water will not create danger or nuisance; but in an easily visible position.

5.7 Electrical Connections

- 5.7.1 The electricity supply must be as specified in clause 4.7. If controls external to the appliance are required, design of the external electrical circuits should be undertaken by a competent person.

See Section 10 for further advice.

N.B. IT IS ESSENTIAL THAT ALL EXTERNAL CONTROL CIRCUITS AND WIRING IS WIRED FROM THE SAME ELECTRICAL ISOLATOR AS SERVES THE APPLIANCE.

Factory fitted internal wiring must not be disturbed when wiring external controls.

- 5.7.2 To gain access to the electrical terminals hinge down the spring loaded control fascia. (ref. to fig. 19) until it rests in an approximately horizontal position.

The terminal block is located under a black plastic cover mounted on the right hand support bracket for the control fascia remove the screw for access. The bottom half of the terminal block unplugs for easy wiring of the electricity supply.

- 5.7.3 The electricity supply cable from the isolator and the appliance terminal block must be 3 core flexible sized 0.75mm² (24 x 0.2mm) to table 15-16, BS6500.

Wiring to the appliance should be rated for operation in contact with surfaces up to 90°C.

Fig. 19

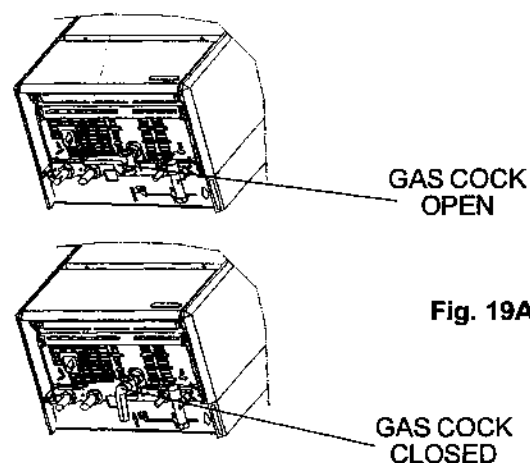
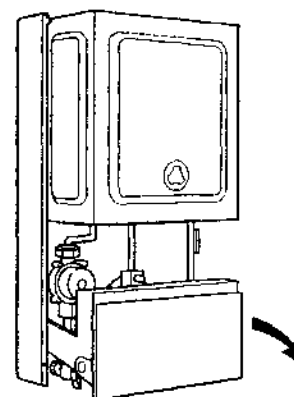

5.7.4 Pass the cable through the cord anchorage and connect the wires Brown to L Blue to N and Green/Yellow to \uparrow , arrange the cable so that should the cable slip the anchorage the current carrying conductors become taut before the earthing conductor.

NOTE: No other terminals on this plug should be used for any electrical connections.

5.7.5 Securely tighten all terminal screws and replace the plug into the socket mounted on the frame, arrange the cable with slack between the cable anchor and the terminal block. Tighten the cord anchorage screw until the cable is secure.

5.7.6 Neatly arrange the external cable in such a way that unrestricted opening of the controls fascia is possible without strain on the cable.

5.7.7 External controls may be wired from the terminal block mounted on the back of the front fascia panel.

NOTE THE TERMINALS MARKED L & N ARE 230v TO OPERATE THE CLOCK MOTOR (SHOULD AN EARTH CONNECTION BE REQUIRED UTILISE THE EARTH SCREW BESIDE THE MAINS INPUT TERMINAL BLOCK).

THE TERMINALS 1 & 3 ARE 24v AND ARE ONLY USED FOR THE SWITCHING CIRCUITS OF TIME CLOCKS AND/OR ROOM THERMOSTATS (AFTER REMOVING THE FACTORY FITTED LINK). (SEE SECTION 10 FOR MORE DETAILS).

If required pass the external controls cable through the same cord anchorage and arrange the cable so that should the cable slip the anchorage, the current carrying conductors become taut before the earthing conductor.

SECTION 6 COMMISSIONING

- 6.1** Where the text bears identifying numbers in brackets, refer to figs. 1 and 2 unless otherwise instructed. Close control panel, open controls cover.
- 6.2 Gas Supply Installation**
Inspect the entire installation including the meter, test for soundness and purge, all as described in BS6891:1988.
- 6.3 Central Heating Systems**
- 6.3.1 IMPORTANT DO NOT RELEASE AIR FROM THE RED SEALED EXPANSION TANK.** It is charged with air at the factory to 1 bar (15psig)
- 6.3.2 Initial Flushing of the Pipework**
The appliance contains components likely to be damaged or blocked by grease and dirt from the system. It is recommended therefore that the appliance be disconnected from the system for the initial flush.
- 6.3.2.1** Close the appliance central heating valves and disconnect from the appliance (15 & 16, Fig. 1).
Connect a temporary water supply to the return and a drain pipe to the flow and flush the entire system until the drain discharges clean water for at least five minutes.
Drain the system by opening the drain taps at all low points. Close the drain taps and reconnect the flow and return valves to the appliance.
- 6.3.3 Initial filling of the System**
- 6.3.3.1** See Clause 3.4.4 and 4.6.8
- 6.3.3.2** Open central heating flow and return valves (if the indicating line on the square shank is vertical it indicates open, horizontal indicates closed). Unscrew black cap on automatic air release valve (22) one full turn (leave open permanently).
- 6.3.3.3** Close all air release taps on the central heating system.
- 6.3.3.4** Gradually open stopcocks at the filling point connection to the central heating system until water is heard to flow. Do not open fully.
- 6.3.3.5** Starting with the lowest radiator open each air release tap in turn closing it only when clear water, free of bubbles, flows out. In the same way release air from any high points in the pipework.
- 6.3.3.6** Continue filling the system until at least 1.0 bar registers on the gauge then turn off the filling point stopcocks.
- 6.3.3.7** Inspect the system for water soundness and remedy any leaks discovered.
- 6.3.4 Setting the System Design Pressure**
- 6.3.4.1** The design pressure must be a minimum of 1 bar and maximum 1.5 bar.
- 6.3.4.2** The actual reading should ideally be 1 bar plus the equivalent height in metres to the highest point of the system above the base of the appliance up to the maximum of 1.5 bar total).
N.B. The safety valve is set to lift at 3bar / 30m / 45psig.
- 6.3.4.3** To lower the system pressure to the required value, turn the red knob of the safety valve (18) a quarter turn to release water until the required figure registers on the gauge (28).
- 6.3.5 Filling the Hot Water System**
- 6.3.5.1** Close all hot water draw-off taps.
- 6.3.5.2** Open cold water inlet stopcock (13)
- 6.3.5.3** Slowly open each draw-off until clear water is discharged.
- 6.4 Checking Electricity Supply**
- 6.4.1** Carry out preliminary checks for continuity, polarity, and resistance to earth, gaining access as required according to clause 5.7.2 in this manual.
- 6.4.2** Leave the appliance with the control fascia closed and with the mains electricity switched OFF
- 6.5 Lighting the Boiler**
- NOTE:** When the appliance is turned on for central heating it will light at a reduced gas rate for approx. 2 mins. before going to maximum output.
In domestic hot water mode there are no delays in the ignition sequence.
- 6.5.1** Ensure flow and return valves are open (Cl 6.3.3.2)
If external controls are fitted (e.g Timeclock and Room thermostat) ensure they 'call for heat'. The commissioning of the appliance may be easier if the external controls are disconnected and terminals 1 & 3 linked. (For access procedure turn off electricity and refer to clause 5.7.2 for instructions).
- 6.5.2** Switch on the mains electricity and turn the on/off/mode switch (32) to 
- 6.5.3** Set the control knob (31) to the highest setting.
- 6.5.4** The appliance will go through an ignition sequence and the burner will light. (at a reduced rate for approx. 2 mins. before going to maximum output).

- 6.5.5** If during the ignition attempt period (10 secs approx.) the boiler fails to light, the ignition control circuit will go to lockout, this is indicated by the status L.E.D. on the control fascia flashing red along with the red lockout L.E.D. illuminated. The gas valve is de-energised, but leaves the fan and pump running.
- 6.5.6** In the event of the boiler going to lockout turn the on/off switch to the reset position. The two main causes of the boiler going to lockout during commissioning are electrical supply polarity reversed, or air in the gas supply. Check polarity and that the gas supply is completely purged of air and that gas is reaching the boiler then repeat from 6.5.2.
- 6.6 Checking Burner Pressures**
- 6.6.1** The heat inputs for high and low gas rates are factory set to the maximum values given in section 3.12 for domestic hot water and central heating but it is necessary to check them when commissioning.
- 6.6.2** The maximum heat input for the central heating mode may be reduced by a simple adjustment to suit the system load. This in no way affects the appliance maximum which is always obtained in the domestic hot water mode.
- 6.6.3** Turn off the main electricity supply. Gain access to the interior as instructed in clause 5.7.2.
- 6.6.4** Locate the main burner pressure test point (Fig. 20) and slacken the screw half a turn in an anti clockwise direction. Attach a suitable pressure gauge. Turn on electricity supply and fully open a domestic hot water tap to operate boiler in dhw mode. Adjust hot water control knob to it's maximum setting.
- 6.6.5** The pressure reading for maximum rate should be.
- 80E (N/G)**
11.2mbar/4.5in wg
(plus or minus 1.1mbar/0.45in wg)
- 96E (N/G)**
11.0mbar/4.7in wg
(plus or minus 1.1mbar/0.45in wg)
- If the pressure is wrong it should be adjusted as instructed in clause 8.24 (N.B. Whenever the maximum rate is adjusted check and adjust the minimum rate too)
- 6.6.6** Reduce the domestic water flow rate to approx. 3-4 litres/min, turn the domestic control knob slowly to minimum the boiler output will reduce to the minimum setting. If low flame cannot be established in this way, turn off the electricity supply, release the modulator coil retaining clip and slide the modulator coil off the brass rod. Switch on the electricity supply, the boiler will now light at the minimum setting.

- 6.6.7** When low flame is established, the pressure reading should be.
- 80E (N/G)**
1.7mbar/0.68in wg
(plus or minus 0.17mbar/0.07in wg)
- 96E (N/G)**
1.3mbar/0.52in wg
(plus or minus 0.13mbar/0.05in wg)
- If it is different adjustment should be made in accordance with the instructions in clause 8.24.
- 6.6.8** If the modulator coil was removed to check the minimum setting, turn off the electricity supply and replace the modulator coil ensuring correct location of clip
- 6.6.9 Checking Ignition Heat Input (Soft Light Ignition).**
- 6.6.10** The soft light ignition pressure is factory set, but it is necessary to check it when commissioning.
- 6.6.11** Turn off the main electricity supply.
- 6.6.12** Disconnect the sensing electrode lead from the terminal marked FS1 on the ignition control box.
- 6.6.13** Turn on the main electricity supply and turn on a domestic hot water tap to operate the boiler in dhw mode.
- 6.6.14** The boiler will now light at a reduced pressure, the reading should be 4.0mbar/ 1.6in wg (plus or minus 0.4mbar/0.16in wg) (N/G) If the pressure is incorrect it should be adjusted as in clause 8.24
- N.B.** while checking the soft light pressure the burner will only light for approximately 10 seconds before going to lockout.
- 6.6.15** Turn off the main electricity supply and reconnect the sensing electrode lead to terminal FS1 of the ignition control box.

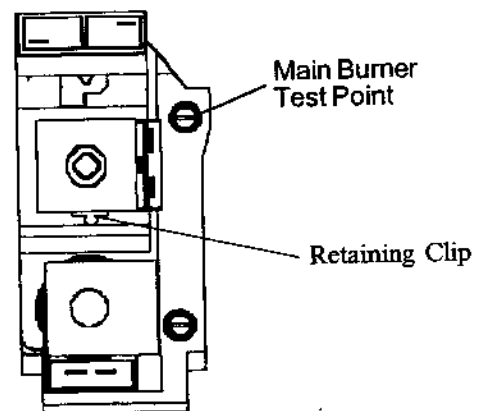

Fig. 20

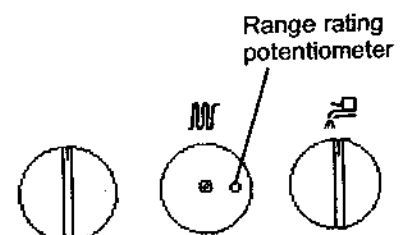

Fig. 21

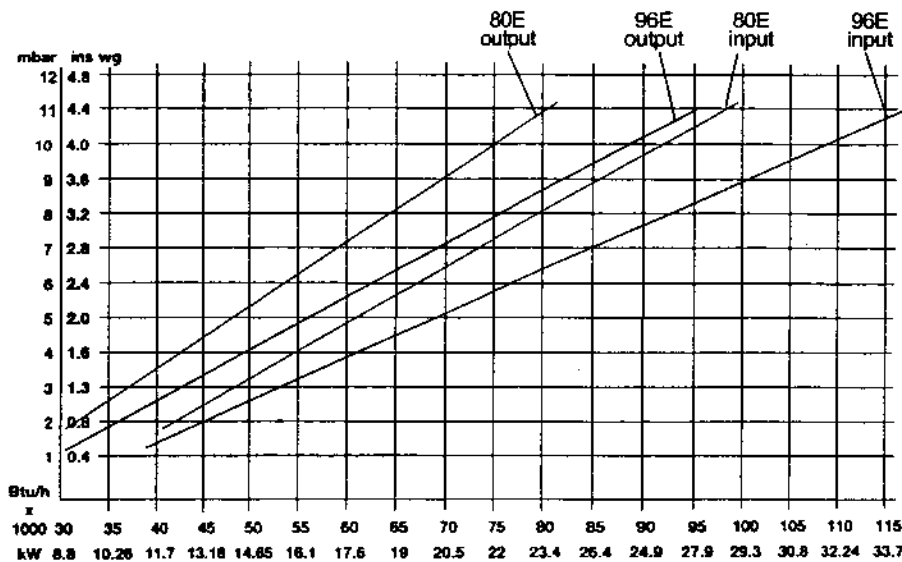

Fig.22

6.6.16 Setting the Maximum Rate for Central Heating (Range Rating)

Refer to fig. 22 to determine pressure for the heating output you need. Turn on the heating with the control knob set at maximum, wait for the burner to reach main flame, Pull off the heating control knob, use a small screwdriver to adjust the potentiometer fig. 21 until the required pressure is indicated on the gauge. Once this pressure has been fixed it should be indelibly recorded on the label provided and affixed next to the data badge. This is to ensure that the burner can be reset when any service operation involves alteration of burner settings.

6.7 Checking the Flue System

6.7.1 The flue system should be visually checked for soundness. Check all clamps and fixings are secure and tight.

6.8 Checking the Heating Thermostat

6.8.1 Allow the system to warm up and manipulate the c/h control knob to ensure that the burner modulates between 'high' and 'low' and then to 'off' and vice versa (scale range covers approx. 45° - 85°C).

6.9 Regulating the Central Heating System

- 6.9.1 Fully open all radiator and circuit valves and run the appliance in the central heating mode until heated water is circulating. If conditions are warm, remove any thermostatic valve heads.
- 6.9.2 If the burner will not light, ensure that water is in fact circulating See cl 4.6.3
- 6.9.3 Adjust radiator return valves and any branch circuit return valves until the individual return temperatures are correct and are approximately equal.
- 6.9.4 When all is adjusted, progressively close all radiator valves to ensure that the appliance still operates when flow through the system is limited.

If the burner cuts out prematurely due to lack of water flow through the appliance, the system should be regulated to ensure a flow rate of at least 350 litres/h (78 gals/h). This may mean the addition of a small manual by-pass being fitted to the system if a fully TRV system is used.

6.10 Final Flushing of the Heating System

6.10.1 After the system has been thoroughly heated to about 60°C (140°F) or above, and hot water has circulated to all parts any residual grease, flux and other foreign material will have been dislodged.

6.10.2 Inspect the system for soundness. Turn the appliance off at the on/off switch (fig. 1 No.32).

Open all drain taps and quickly drain the system whilst still hot to remove offending substances. Refill as instructed in clause 6.3.3.

6.11 Filling, Testing and Regulating the Domestic Hot Water System

6.11.1 Start with the appliance switched on having completed the procedures described in clause 6.4 to 6.10.

6.11.2 Open a domestic hot water tap (Preferably the bath tap).

Ensure cold water inlet stopcock is fully open and the dhw control knob (30) is set at maximum.

6.11.3 The flow of water should activate the differential pressure device and drive the diverting valve (20) to its other position thus heating the domestic water flowing through the dhw heat exchanger. At the same time the domestic micro-switch (19) is activated lighting the burner on maximum rate.

6.11.4 If the burner does not light, check that the water flow rate is above the minimum required to operate the differential pressure device 2.8 litres/min (0.61 gals/min).

- 6.11.5 The temperature of the water will depend on the rate at which it flows.

If, due to high water pressure the flow rate is unacceptably high (and thus the temperature too low for practical use) the flow rate should be adjusted as follows. (see Fig. 22a)

- 6.11.6
- Adjust the flow using the stopcock until the required temperature is reached.
 - Unscrew the screw (1) and remove the knob (2).
 - Adjust the ring (3) anti clockwise until it reaches the stop.
 - Refit the knob aligning the register in the knob with the one on the ring.
 - Replace the screw.

Fig.22a

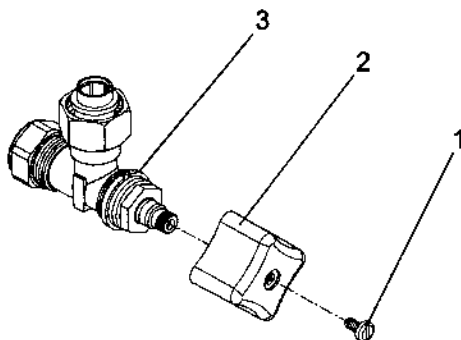

It is best to set for the lowest acceptable temperature since the user can gain higher temperatures by restricting flow at the tap.

N.B. If the cold supply is subject to large fluctuations or is above the permitted maximum a suitable pressure/flow regulator should be fitted in the cold water supply to the appliance.

- 6.11.7 Turn the appliance mode selector switch (32) to the  position. Slowly close the tap to reduce the draw off rate to above the minimum approx. 2.8 litres/min (0.61 gal/min) Rotate the dhw control knob to ensure the appliance modulates at its various setting.
- 6.11.8 Close the draw-off tap still further. The burner should stop when the rate falls below approximately 2.8 litres/min (0.61 gal/min).
- 6.12 **Final Check for Operations**
- Turn off at On/Off switch, disconnect pressure gauge, retighten screw. Relight boiler.
- 6.12.1 Re-check for gas soundness
- 6.12.2 Re examine heating and hot water systems and cold water supply for water soundness.
- 6.12.3 Check the appearance of the gas flame to assess adequacy of combustion air supply.
- 6.12.4 Re-check the flue system for soundness and adequacy of supports.

6.13 Concluding Operations

- 6.13.1 If external controls have been disconnected and terminals 1 & 3 temporarily linked remove the link and reconnect the external control circuit, check the operation of the external controls.
- 6.13.2 Hinge up the control fascia.
- 6.14 Refixing the Front Cover fig. 23
- 6.14.1 Offer up the front casing to the back frame in a near vertical attitude and locate the hooks on the casing over the hooks on the frame. Slide the casing downwards to fully engage the hooks and to align the bottom fixing holes. Replace the four case retaining screws. (fig. 23)
- 6.14.2 Clip valve cover (fig. 23A) into place and retain using the two retaining buttons by pushing them through the holes and turning through 90°.
- 6.15 Supplementary Instructions for Fitting & Removing Optional Time Clock and for Wiring to External Controls.

Section 10 Appendices A and B at the rear of this manual provides full instructions for fitting and wiring the optional built-in time switches and for wiring to external controls.

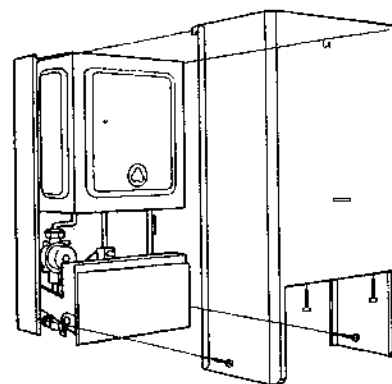

Fig. 23

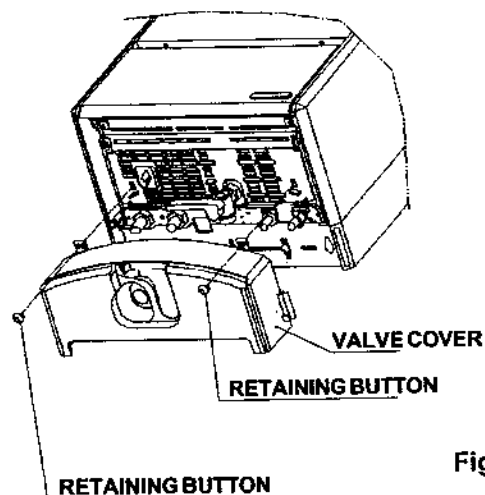

Fig. 23A

SECTION 7 INSTRUCTING THE USER

- 7.1 Hand over the copy of the Users Instructions supplied with the appliance, together with these instructions, and explain how to operate the boiler correctly and explain how to use the timeclock and room thermostat if fitted.
- 7.2 Show the user how to switch off the appliance quickly and indicate the position of the electric supply isolator.
- 7.3 Inform the user of the location of all drain cocks and air vents.
- 7.4 Explain how to turn the appliance off for both short and long periods and advise on the precautions necessary to prevent damage should the appliance be inoperative when freezing conditions may occur.
- 7.5 Finally, advise the User that, for continued safe and efficient operation, the appliance must be serviced by a competent person at least once a year.

SECTION 8 SERVICING INSTRUCTIONS

8.1 General

To ensure the continued safe and efficient operation of the appliance, it is recommended that it is checked and serviced as necessary at regular intervals.

The frequency of servicing will depend upon the particular installation conditions and usage, but in general, once per year should be adequate.

It is the law that any servicing work is carried out by a competent person such as British Gas or other CORGI registered personnel.

The following instructions apply to the boiler and its controls, but it should be remembered that the central heating and domestic hot water systems will also require attention from time to time.

8.2 Important Notes

WARNING: Having carried out preliminary flame checks and before starting any servicing work, switch OFF the mains electricity supply and disconnect the plug at the main isolating switch and socket. (If a switch is used remove the fuse.)

Turn off gas supply at the gas service tap fitted to the appliance.

Always test for gas soundness after any service work and after exchanging any gas carrying component.

8.3 Recommended Routine Servicing

8.3.1 Annual Servicing

When servicing is required the following procedures should be carried out.

1. Inspect exterior for signs of damage and deterioration particularly of flue pipework and electrical connections.

2. Turn off mains electricity and remove front casing (see clause 8.4.).

3. Replace fuse if previously removed (8.2. above) and turn on electricity, run the boiler for a few minutes in the domestic hot water mode to permit inspection of its operation. This is accomplished by opening a domestic hot water draw off tap and inspect burner for yellowing of flame tip, flame lift off or sooting.

4. Ensure central heating valves fig 1 - 16 & 17 are open. Note these are 1/4 turn valves which are open when the line on the square shank is vertical, closed when the line is horizontal.

Observe pressure gauge reading fig.1 - 28 which should be approximately 1 bar when the system is cold (see clause 6.3.3)

5. Turn off mains electricity and turn off gas service tap on the appliance.

6. Gain general access as described in clause 8.4.

7. Remove main burner (see clause 8.6) Lightly clean with a soft brush and inspect for damage. If during initial inspection, any combustion irregularity was suspected, remove injectors and clean or replace (see clause 8.7).

8. Place cloth below combustion chamber to catch debris. Clean heat exchanger using suitable brushes and rods if necessary.

9. Inspect combustion chamber lining. The insulating material is easily damaged. Do not scrape, but clean off lightly.

If any panels are damaged these should be replaced (see clause 8.11).

10. Replace all parts in reverse order but leave the controls fascia open and outer casing off.

11. Undertake a complete commissioning check as detailed in section 6.

12. Close up control fascia and refix front casing.

13. Clean off casing using soft cloth and dilute detergent.

NOTE: There is a flue gas analysis test point incorporated in the flue outlet. (see fig. 26)

8.3.2 Replacement of Parts

1. The life of individual components varies and they will need servicing as and when faults develop. The fault finding sequence charts in section 9 will serve to locate which component is the cause of any malfunction, and instructions for removal, inspection and replacement of the individual parts are given in the following pages.

2. The domestic hot water heat exchanger may in certain conditions become partially blocked by scale deposits. Evidence of this will be deterioration in performance.

This condition could well be treated using proprietary descalants following makers instructions without dismantling the appliance by circulating a fluid through the dhw coil. To do this, disconnection from hot and cold services is necessary. Reconnect only after thorough flushing with clean water.

8.4 To Gain General Access/Assembly

To remove components access to the interior is essential. Refer to fig. 24.

Ensure electricity supply is isolated before carrying out any servicing.

8.4.1 To remove front casing.

Release 4 retaining screws fig. 24.

Pull bottom of case slightly forward and push case upwards to disengage from top support hooks and withdraw the case from the appliance.

The control panel can now be hinged down for access.

8.4.2 Reassembly is always carried out in reverse order to dismantling, unless otherwise stated. Electrical connections must be remade in accordance with the wiring diagram figs. 38 & 39.

8.4.3 Wherever gas control components are replaced, check the burner pressures and adjust if necessary (Section 8.24)

8.4.4 If required remove lower plastic grill by removing 2 vertical screws and pull grill downwards.

8.5 Room Sealed Chamber Front Cover (Including Viewing Window).

Part No. 5904 Refer to fig. 25

8.5.1 Gain general access as 8.4

8.5.2 Remove room sealed front cover plate by releasing eight screws fig. 25) and easing cover off. The screws are not captive. Inspect gasket for damage. If damaged, replace.

NOTE: When refitting the Room sealed chamber front cover it is essential to correctly seat and secure the cover in place ensuring all screws are tightened.

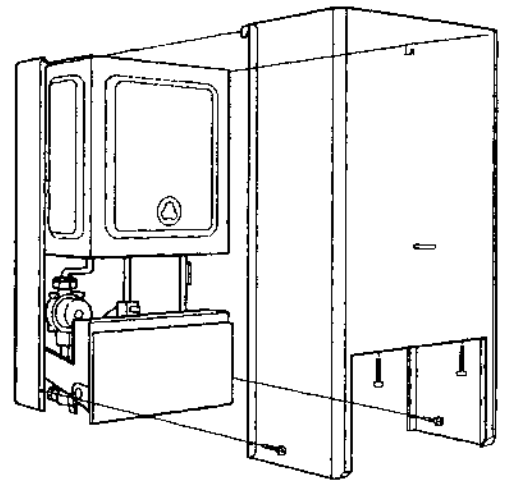

Fig. 24

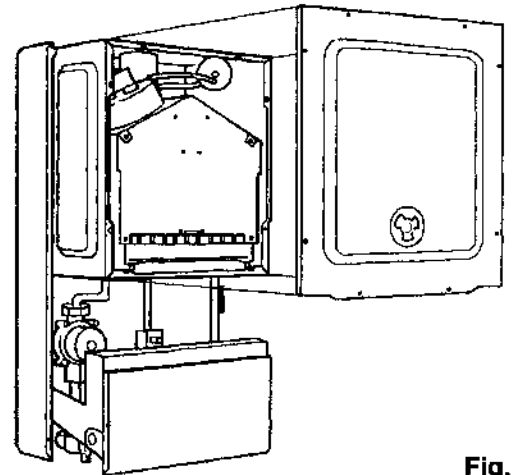

Fig. 25

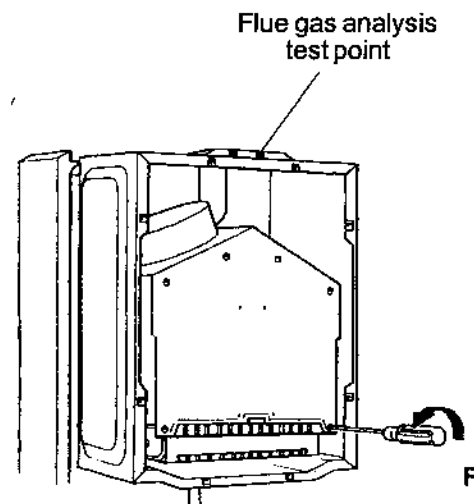

Fig. 26

8.6 Main Burner and/or Spark and Sensing Electrodes

Part No's
Main burner 80E - 7095 96E - 7096
Spark Electrode - 5640
Sense Electrode - 5853
Refer to fig. 27 & 28

- 8.6.1 Gain general access as 8.4
- 8.6.2 Remove room sealed front cover 8.5
- 8.6.3 Remove front of combustion chamber by releasing six screws fig. 26
- 8.6.4 Remove four burner retaining screws fig. 28 ease burner forward and rest on chamber base.
- 8.6.5 Release electrode retaining screws Carefully remove electrodes.
- 8.6.6 Trace electrode lead to electronic ignition control and disconnect.
- 8.6.7 Repeat for other electrode.
- 8.6.8 Remove main burner. Reassemble in reverse order ensuring correct location of electrodes. Ensure that left hand electrode is connected to the FS1 terminal on electronic ignition control box.

Note: If difficulty is found in relocating the burner securing screws, easy access can be gained by removing the two side panels fig. 27.

8.7 Main Burner Injectors

- 8.7.1 Gain general access as 8.4
- 8.7.2 Remove room sealed front cover plate and combustion chamber front (8.5 & 8.6.3).
- 8.7.3 Remove main burner (8.6.4 to 8.6.8).
- 8.7.4 Unscrew injector(s).

8.8 Main Heat Exchanger

Part No. 80E - 5351 96E - 5356
Refer to Fig. 28

- 8.8.1 Gain general access as 8.4
- 8.8.2 Remove room sealed front cover plate (8.5).
- 8.8.3 Remove front of combustion chamber (8.6.3).
- 8.8.4 Remove two air baffle plates. 1 screw securing each.
- 8.8.5 Remove both side panels, 2 screws each fig. 27
- 8.8.6 Close heating flow and return valves fig. 1, 15 and 16) by turning 1/4 turn until indicating lines are horizontal. Turn safety valve 1/4 turn to drain primary circuit of boiler.
- 8.8.7 Place cloth under heat exchanger to catch surplus water.

8.8.8 80E

Unscrew unions on either side of main heat exchanger.

96E

Disconnect upper flanges by removing 2 screws on each flange.

8.8.9

Slide out main heat exchanger, taking care not to damage insulation panels. Avoid spillage of water on boiler electrics.

8.8.10

Reassemble in reverse order using new fibre washers in unions.

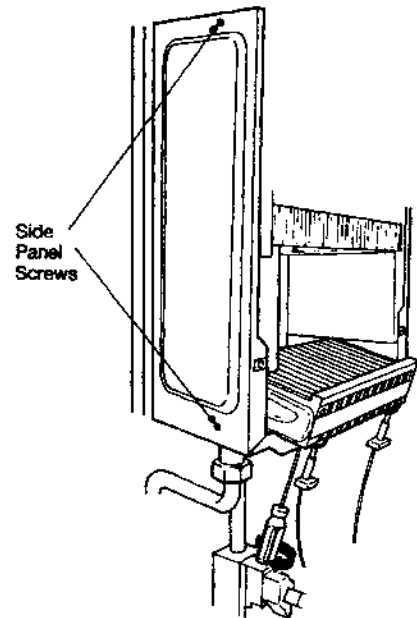

Fig. 27

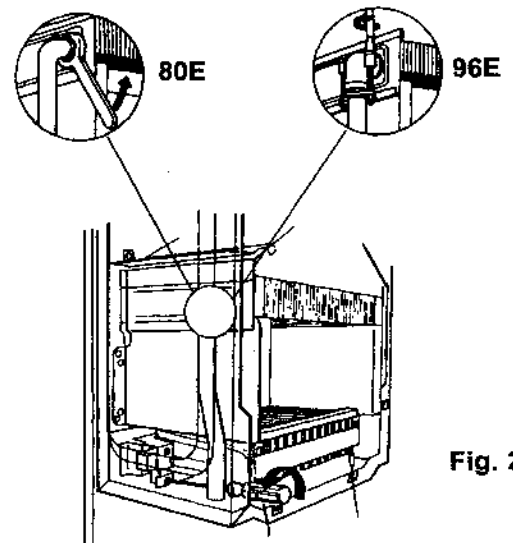

Fig. 28

- 8.9 Flue Fan**
Part No. 80E - 5910
96E - 5911
- 8.9.1** Remove room sealed front cover plate (8.5) and front of combustion chamber (8.6.3).
- 8.9.2** Loosen maintenance clip securing screws (see fig. 29) and slide upwards to clear joint.
- 8.9.3** Remove silicone pipes from nozzles on inner flue bend
- 8.9.4** Remove 3 flue hood retaining screws (see fig. 29)
- NOTE: (i) When removing the two side screws the two air baffle plates can be removed. (ii) The centre screw is captive.
- 8.9.5.** Carefully slide flue hood forward disconnecting electrical leads on fan in the process.
- 8.9.6** Unscrew 4 screws securing fan to flue hood and remove fan. Transfer aluminium manifold (two screws) to new fan.
- 8.9.7** Reassemble in reverse order, replacing centre hood screw first.
- 8.10 Flue Pressure Differential Switch**
Part No 7070
Refer to Fig. 29
- 8.10.1** Gain general access as 8.4
- 8.10.2** Remove room sealed cover (8.5)
- 8.10.3** Remove 2 screws holding pressure differential switch to the combustion chamber.
- 8.10.4** Pull off tab connectors and remove pressure switch, disconnecting the air pressure pipes in the process.
- 8.10.5** Reassemble in reverse order.
- See fig. 39 for correct fitting of electrical connections. When reconnecting the pressure pipes the upper nozzle on the inner flue bend connects to the front nozzle of the pressure differential switch.
- 8.11 Combustion Chamber Insulation Boards**
- 8.11.1** Gain general access as 8.4
- 8.11.2** Remove room sealed front cover 8.5
Remove front of combustion chamber 8.6.3.
Close Heating Valves.
Remove Main Heat Exchanger 8.8.
- 8.11.3** To remove side combustion chamber insulation boards. Gently prise upwards and pull out.
- 8.11.4** To remove rear board. Gently prise upwards and pull out.
- 8.11.5** Fourth panel (front) is replaced complete with combustion chamber front panel.
- 8.12 To Remove/Replace Gas Control Valve, Modulator and Operators.**
Refer to figs. 30 - 31
- 8.12.1** Gain general access 8.4
- 8.12.2** Turn off gas service tap.

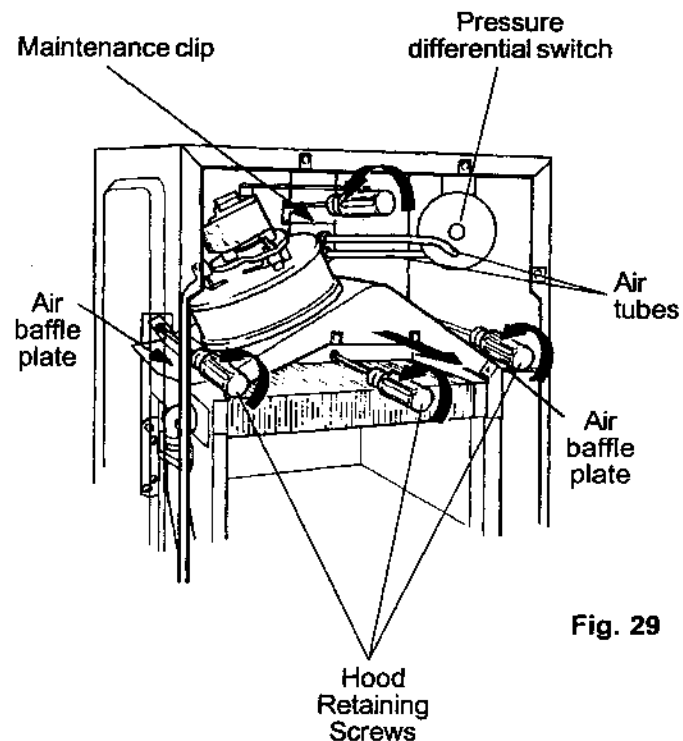

Fig. 29

- 8.12.3 Modulator Coil**
Part No. 6901
- 8.12.4** Pull off electrical leads from tab connectors.
- 8.12.5** Release retaining clip from rear of modulator coil (see fig. 20).
- 8.12.6** Remove modulator coil.
- 8.12.7** Replace in reverse order (see fig. 39 for electrical connections).
- 8.12.8** Check burner pressures (cl 6.6).
- 8.12.9 Servo Pressure Regulator**
Part No. 0680
- 8.12.10** Turn of gas service tap.
- 8.12.11** Pull off all electrical leads from modulator and operator tab connectors, also remove earthing tags.
- 8.12.12** Remove modulator coil 8.12.3
- 8.12.13** Release 4 screws securing regulator to valve body.
- 8.12.14** Remove regulator from valve body.
- 8.12.15** Carefully place new gasket in position on valve body and fit replacement regulator, taking care not to displace the gasket.
- 8.12.16** Replace 4 screws and tighten.
- 8.12.17** See fig. 39 for electrical connections.
- 8.12.18** Check burner pressures as clause 6.6

- 8.12.19 Solenoid**
Part No. 0681
- 8.12.20** Pull off electrical leads from solenoid.
- 8.12.21** Remove the spring blade retaining clip.
- 8.12.22** Pull off the 'C' bracket and coil assembly, see fig. 31
- 8.12.23** Place new coil in 'C' bracket and slide the assembly back onto the solenoid post.
- 8.12.24** Push the retaining clip back into position and check that bottom of clip has engaged in groove at base of solenoid post.
- 8.12.25** See fig. 39 for electrical connections.
- 8.13 Gas Control Valve (complete)**
- 8.13.1** Gain access 8.4. Turn off gas supply. Disconnect earth lead. Pull off all electrical connections to operators and remaining modulator coil.
- 8.13.2** Remove servo pressure regulator and modulator coil. Clause 8.12.3 & 8.12.9
- 8.13.3** The operators etc. can be transferred to any new valve to retain regulation settings.

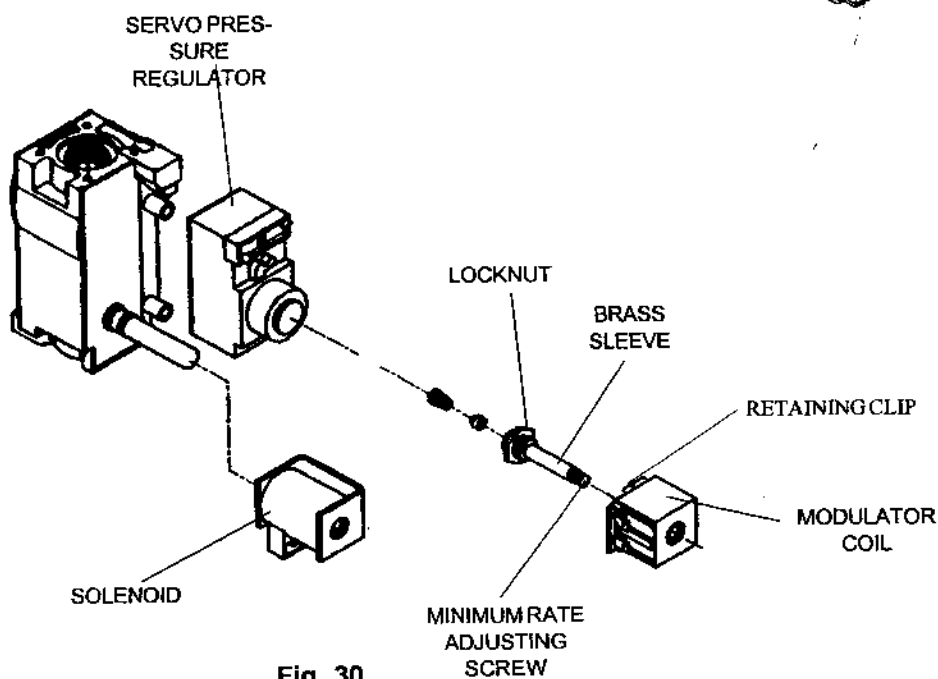

Fig. 30

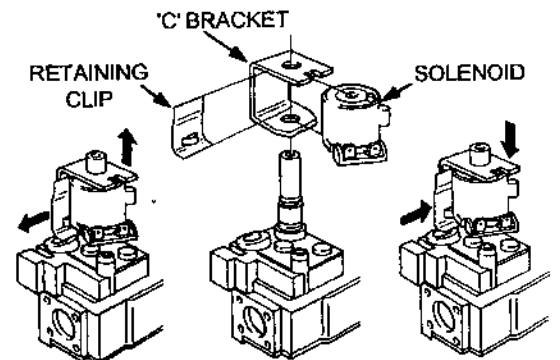

Fig. 31

- 8.13.4 Remove 4 flange securing screws at the lower end of the gas valve.
- 8.13.4 Undo union above the gas control valve.
- 8.13.5 Remove 2 screws securing gas valve bracket to the base frame and withdraw valve.
- 8.13.6 Transfer bracket and gas connecting pipe from gas valve to new valve using a new gasket on the flange connection.
- 8.13.7 Replace valve assembly into the appliance in reverse order using new gasket on the lower flange.
- 8.13.8 Test all joints for gas soundness.
- 8.13.9 Check burner pressures (cl 6.6).
If incorrect adjust as instructed in cl 8.24
- 8.14 **Pump**
Part No 6025
- 8.14.1 Gain general access as 8.4
- 8.14.2 Close heating flow and return valves fig. 1, 16 & 17 by turning 1/4 turn until indicating lines are horizontal.
- 8.14.3 Drain appliance via safety valve by 1/4 turn of safety valve knob.
- 8.14.4 **HEAD ONLY** Unscrew the 4 allen screws around the pump head. Pull head from base of pump and disconnect electrical leads. If replacement required, use the head from a standard 15-50 pump.
- 8.14.5 **COMPLETE PUMP** Disconnect pipe union connection at front left corner of combustion chamber.
- 8.14.6 Loosen grub screw just below lower pump union (Fig. 32).
- 8.14.7 Grasp pump and pull upwards with slight twisting movement to release pump from manifold.
- 8.14.8 Disconnect electrical leads from pump.
- 8.14.9 Unscrew automatic air vent from pump housing and transfer to new pump.
- 8.14.10 Transfer pump unions to new pump using new gaskets.
- 8.14.11 Reassemble in reverse order.
Reconnecting electrical leads Brown to L, Blue to N and Green to E.
- 8.15 **Removal of Hydraulic group**
Refer to figs. 32 & 33
- 8.15.1 Gain general access as 8.4
- 8.15.2 Place receptacle or an absorbent pad below appliance to catch trapped water.
- 8.15.3 Remove pump (complete) 8.14
- 8.15.4 Remove domestic hot water heat exchanger as 8.17.
- 8.15.5 Disconnect the hot water and flow microswitches from the hydraulic group by unscrewing one retaining screw on each bracket.
- 8.15.6 Remove cold water connecting pipe (fig 32 (A)) by undoing the unions at both ends.
- 8.15.7 Disconnect flow tube union where it connects onto the hydraulic group. (fig.32 (B)).
- 8.15.8 Disconnect expansion vessel pipe (fig.32 (C)).
- 8.15.9 Unscrew pressure gauge connection retaining screw and pull out pressure gauge connection.
- 8.15.10 Disconnect safety valve discharge pipe and heating valve unions.
- 8.15.11 Remove retaining screw securing hydraulic group to frame.
- 8.15.12 Withdraw hydraulic group from appliance. See fig.33 for location of components.

Reassemble in reverse order ensuring that washers are replaced in all union connections.
- 8.16 **Fulcrum Arm**
- 8.16.1 Gain general access as 8.4
- 8.16.2 Remove screw from pivot point of arm (access to screw is from underside of arm)
Note: nut is not captive.
- 8.16.3 Remove arm.
- 8.17 **Removal of Domestic Hot Water Heat Exchanger**
Refer to figs. 32 & 33
- 8.17.1 Gain General access (8.4)
- 8.17.2 Place receptacle or an absorbent pad below appliance to catch trapped water.
- 8.17.3 Close cold water inlet stopcock.
- 8.17.4 Open lowest draw-off or drain tap on hot water system.
- 8.17.5 Close heating flow and return valves fig. 1, 16 & 17 by turning 1/4 turn until indicating lines are horizontal.
- 8.17.6 Drain appliance via safety valve by 1/4 turn of safety valve knob.
- 8.17.7 Remove fulcrum arm as 8.16.
- 8.17.8 Remove domestic heat exchanger retaining screw. (access to screw head via hole in hydraulic section behind fulcrum arm.
- 8.17.9 Remove elongated brass nut on right hand side of domestic heat exchanger using a 7mm spanner.
- 8.17.10 Gently release heat exchanger from o'ring seal by rocking to the rear and remove.
- 8.17.11 Reassemble in reverse order, using new o'rings if required.

8.18 Diverter Valve

Refer to fig. 33

- 8.18.1 Gain general access 8.4
- 8.18.2 Close heating flow and return valves fig. 1, 16 & 17 by turning 1/4 turn until indicating lines are horizontal.
- 8.18.3 Drain appliance via safety valve by 1/4 turn of safety valve knob.
- 8.18.4 Remove fulcrum arm as 8.16.
- 8.18.5 Remove hot water microswitch by unscrewing retaining screw on bracket.
- 8.18.6 Remove front of diverter valve by unscrewing four retaining bolts.
- 8.18.7 See fig. 33 for further disassembly and location of components.
- 8.18.8 Reassemble in reverse order.

8.19 Domestic Hot Water Manifold

Refer to fig. 33

- 8.19.1 Gain general access 8.4
- 8.19.2 Close cold water inlet stopcock and drain secondary side by opening draw-off or drain tap on hot water system.
- 8.19.3 Remove fulcrum arm 8.16
- 8.19.4 Remove flow microswitch by unscrewing retaining screw on bracket.
- 8.19.5 Remove manifold front cover by removing the five cover retaining screws.
- 8.19.6 See fig. 33 for further disassembly and location of components.
- 8.19.7 Reassemble in reverse order.

8.20 Checking/Replacing Main Expansion Vessel

- 8.20.1 The expansion vessel is factory pressurised to 1 bar (14.7psi) and should be checked during servicing. Should it have lost pressure it can be repressurised in situ. Drain the boiler. Fit a suitable pump and gauge (i.e. car foot pump and gauge) to the nipple at the top right-hand side of the expansion vessel, and pressurise to 1 bar (14.7psi) and remove the pump.

NOTE: Access to the nipple can be improved by loosening the upper vessel retaining screws and rocking the vessel forwards.

If the vessel cannot be repressurised or if pressure loss is very frequent the expansion vessel will require changing. Alternatively, a new vessel can be fitted in the return to the appliance, and the old vessel isolated in situ.

- 8.20.2 Gain access 8.4
- 8.20.3 Switch OFF mains electricity and gain general access. Disconnect electricity supply and wiring for external controls from the appliance (read cl. 5.7)
- 8.20.4 Close heating flow and return valves fig. 1, 16 & 17 by turning 1/4 turn until indicating lines are horizontal.
- 8.20.5 Drain appliance via safety valve by 1/4 turn of safety valve knob.
- 8.20.6 Remove screws on large maintenance clip/s (fig. 14) and remove, loosen screws on the small clip/s and disconnect flue.
- 8.20.7 Disconnect all pipe unions at the base of the appliance.
- 8.20.8 Remove lower fixing screws (fig. 13) and lift appliance off upper bracket.
- 8.20.9 Remove two screws securing vessel at top. Disconnect expansion pipe at base of expansion vessel and lift vessel out of the appliance.
- 8.20.10 Reassemble in reverse order, using new fibre washers.

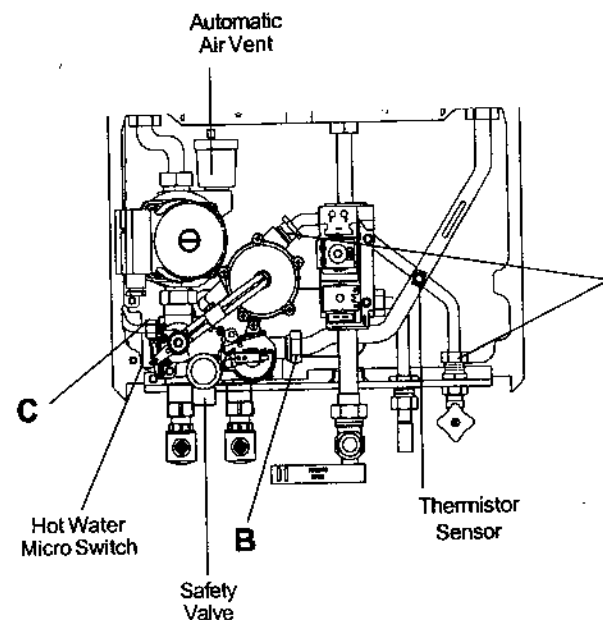
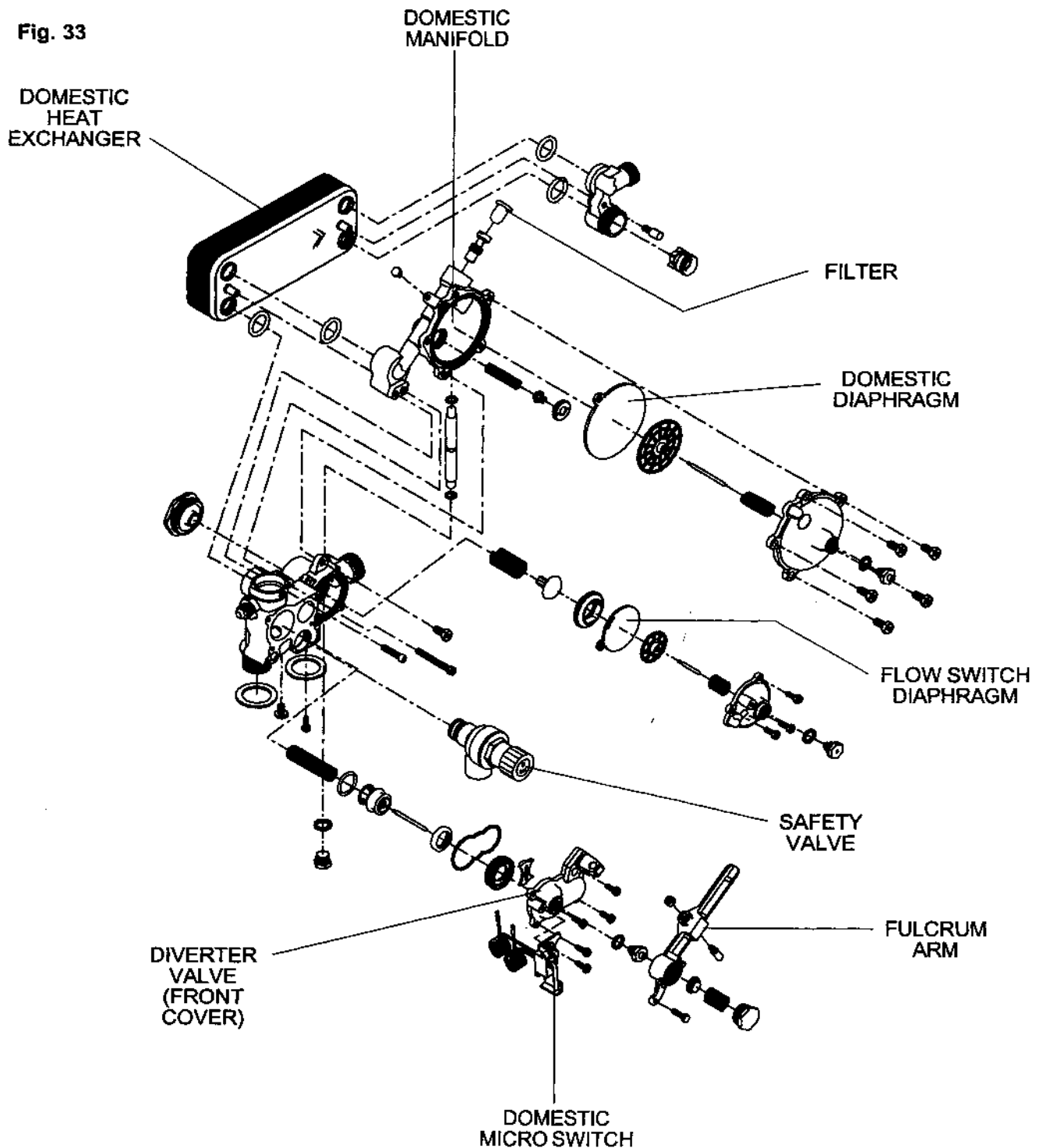

Fig. 32

- 8.21 Safety Valve**
Part No. 8433 Refer to fig.32 & 33
- 8.21.1** Gain General Access 8.4.
- 8.21.2** Close heating flow and return valves fig. 1, 16 & 17 by turning 1/4 turn until indicating lines are horizontal.
- 8.21.3** Drain appliance via safety valve by 1/4 turn of safety valve knob.
- 8.21.4** Unscrew safety valve discharge pipe.
- 8.21.5** Loosen grub screw at base of safety valve & pull forwards releasing valve from o'ring seal.
- 8.21.6** Replace in reverse order.



- 8.22 Removal of Electrical Components**
- 8.22.1** Ensure electricity is switched off at main isolator and gain general access (8.4)
- 8.22.2 Flow Micro Switch**
Part No. 0809 (Fig. 32)
- 8.22.3** Gain general access 8.4
- 8.22.4** Release micro switch from hydraulic group by removing one securing screw.
- 8.22.5** Trace the three electrical wires back to where they connect into the plugs on the electronic control box. Release the two plugs from the box and remove wires by inserting a small screwdriver or spike into the lower recess and pull clear.
- 8.22.6** Reassemble in reverse order ensuring correct location of electrical connections. (see fig. 39 for electrical connections)
- 8.22.7 Domestic Micro Switch**
Part No. 8447 (Fig. 33)
- 8.22.8** Gain general access 8.4
- 8.22.9** Release micro switch from hydraulic group by removing one securing screw.
- 8.22.10** Trace the two grey electrical wires back to where they connect into the plugs on the electronic control box. Release the two plugs from the box and remove wires by inserting a small screwdriver or spike into the lower recess and pull clear.
- 8.22.11** Reassemble in reverse order ensuring correct location of electrical connections. (see fig. 39 for electrical connections)
- 8.22.12 Electronic control Box**
Part No.7097
- 8.22.13** Gain general access 8.4
- 8.22.14** Remove three control knobs from front of control panel (pull off).
- 8.22.15** Pull out five multi plug connectors, two earth leads, spark lead and sensing lead from rear of control box.
- 8.22.16** Remove two screws securing control box to front panel.
- NOTE: During reassembly ensure that the spark electrode lead is connected to the terminal marked f_1 and the earth lead to the terminal marked \oplus .
- 8.22.17 High Limit Thermostat**
Part No 3409
Refer fig. 1 (27)
- 8.22.18** Ensure electricity is switched off at main isolator and gain general access (8.4)
- 8.22.19** Pull off the two electrical connections on the back of the thermostat.
- 8.22.20** Unscrew the black cap, and remove retaining nut.
- 8.22.21** Remove capillary tube retaining clip from flow tube and withdraw sensor probe.
- 8.22.22 Thermistor Sensor**
Part No. 7236
Fig. 32
- 8.22.23** Gain general access 8.4
- 8.22.24** Pull off electrical connections from thermistor.
- 8.22.25** Unscrew thermistor from flow tube.
NOTE This is a dry pocket sensor.
- 8.23 Combined Pressure Gauge and Temperature Gauge**
Part No 7239
- 8.23.1** Gain general access 8.4
- 8.23.2** Close heating flow and return valves fig. 1, 16 & 17 by turning 1/4 turn until indicator lines are horizontal.
- 8.23.3** Drain appliance via safety valve by 1/4 turn of safety valve knob.
- 8.23.4** Trace capillary from back of pressure gauge to connecting point on heating manifold.
- 8.23.5** Unscrew retaining screw beside the capillary tube entry to the manifold.
- 8.23.6** Pull out capillary tube from manifold.
- 8.23.7** Trace capillary tube from back of temperature gauge to sensor.
- 8.23.8** Ease off sensor retaining clip.
- 8.23.9** Squeeze plastic locking lugs behind fascia and press gauge from aperture.
- 8.23.10** Reassemble in reverse order following original route for capillary tubes and ensuring locking lugs are located in the grooves and that the pressure gauge capillary tube retaining screw is refitted.

8.24 Setting Gas Pressures

ALL SETTINGS DONE WITH "U" GAUGE FITTED TO BURNER TEST NIPPLE AS INSTRUCTED IN CLAUSE 6.6

8.24.1 Setting Maximum Rate

Turn off electrical supply to boiler and follow instructions in section 8.4 to gain access.

Refer to Fig. 34

Disengage retaining clip at rear of coil.

Remove the modulator coil from the brass shaft.

Screw fully in by hand the minimum rate adjusting screw in a clockwise direction.

Loosen the locknut on the brass sleeve.

Turn on the electricity supply and the appliance on/off switch, turn on a domestic draw off tap.

The boiler will now light at full flame, if not screw the brass sleeve slowly clockwise until the burner lights.

Adjust the brass sleeve until the correct pressure is obtained on the gauge the correct reading should be:

80E (N/G)

11.2 mbar / 4.5 in w.g.
plus or minus 1.1 mbar / 0.45 in w.g.

96E (N/G)

11.0 mbar / 4.5 in w.g.
plus or minus 1.1 mbar / 0.45 in w.g.

Tighten the locknut ensuring that the reading does not change.

8.24.2 Setting Minimum Rate

Turn the minimum adjusting screw anti clockwise until the minimum gas rate is achieved the correct reading should be:

80E (N/G)

1.7 mbar / 0.68 in w.g.
plus or minus 0.17 mbar / 0.07 in w.g.

96E (N/G)

1.3 mbar / 0.52 in w.g.
plus or minus 0.13 mbar / 0.05 in w.g.

Reassemble the modulator coil on the brass sleeve relocating the retaining clip.

8.24.3 Setting Ignition Heat Input (Soft Light Ignition)

Turn off the main electricity supply.

Disconnect the sensing electrode lead from the terminal marked FS1 on the ignition control box.

Turn on the main electricity supply and turn on a domestic hot water tap to operate the boiler in dhw mode.

The boiler will now light at a reduced pressure, the reading should be

4.0mbar / 1.6in wg
plus or minus 0.4mbar / 0.16in wg (N/G)

If the pressure is incorrect, pull off the hot water control knob, using a small screwdriver adjust the potentiometer fig.35 until the reading is correct.

N.B. while checking the soft light pressure the burner will only light for approximately 10 seconds before going to lockout.

If the setting has not been completed in this time turn off the mains electricity supply and repeat the procedure again.

When adjustments are complete, turn off the main electricity supply and reconnect the sensing electrode lead to terminal FS1 on the ignition control box.

8.24.4 Central Heating (Range Rating) to Set Maximum Rate in Central Heating Mode.

See clauses 6.6.16 for necessary adjustments. Refer to the commissioning rate recorded by the commissioning engineer on the boiler badge.

8.25 End of Servicing

Run through the general commissioning as described in Section 6 as far as they apply.

Refit casing and clean up.

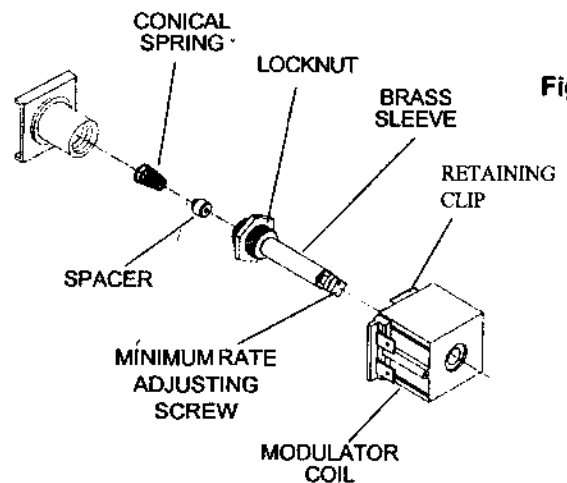

Fig. 34

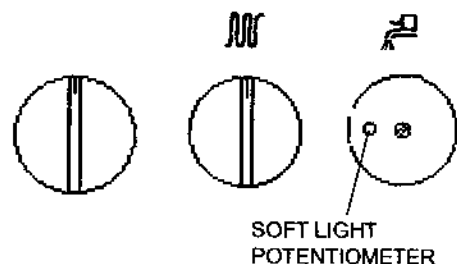

Fig. 35

SECTION 9 OPERATIONAL CHECKS AND WIRING DIAGRAMS

- 9.1** On completion of any service/fault finding task which has required the breaking and remaking of electrical connections, the checks Earth Continuity, polarity and Resistance to Earth must be repeated.

The following flow diagrams suggest the logical sequence of steps for fault finding.

They are not exhaustive but cover all that can reasonably be carried out on site by the installer.

Acquaintance with the functional sequence will prove helpful for some, and this is included for reference. As further help, the role of each part is briefly described.

Also included in this section are wiring diagrams and schematics to assist in fault location and servicing as described in the text.

9.2 Sequence of Functions

When following this sequence, refer to figs.37, 38 & 39. It is assumed that the on/off switch is ON.

9.2.1 Domestic Hot Water Mode

Turning on a tap will cause the domestic diaphragm to move operating the hot water flow microswitch and fulcrum arm.

The fulcrum arm acts on the diverter valve which diverts the primary water to the domestic heat exchanger. Activation of the microswitch will start the fan and pump, the fan will change over the pressure differential switch. With sufficient primary water circulating around the appliance the flow switch is operated. Once these actions have been proven the gas valve will be energised and the electrode will start to spark.

If a flame is detected during the ignition attempt time (8-12 seconds) the sparking will cease and the gas valve will remain energised and the appliance will produce hot water as described below.

If a flame is not detected the appliance will go to lockout (failure to detect a flame during ignition attempt time). At which time the gas valve will be de-energised and the sparking will stop.

To reset the appliance after lockout turn the mode selector switch to the reset position for at least 5 seconds.

The temperature rise of primary water in the appliance is sensed by a thermistor on the flow pipe leaving the main heat exchanger. An increase in temperature will in turn decrease the voltage reaching the modulator coil causing the gas rate to be lowered, if the temperature rise is too great the gas rate can be lowered to such a point that it turns off completely.

Conversely a fall in temperature of the primary water will increase the low voltage to the modulator coil and this in turn increases the gas rate accordingly.

Constant monitoring of the temperature of the primary water by the thermistor will regulate the gas rate to maintain an average heat input.

NOTE: As the thermistor senses the temperature of the primary water leaving the main heat exchanger, the amount of heat transferred from the primary water to the dhw water depends upon the temperature differential between them.

When the dhw water draw off rate drops below the permitted minimum (2.8 l/min) the single micro switch is deactivated, and the appliance either reverts to the 'Rest' mode where the fan may overrun to remove residual heat, or if there is a call for heating to the mode described below.

Central Heating Mode

In this mode the mode selector switch must be turned to the central heating position.

With all controls calling for heat the pump will run and provided sufficient primary water is circulating a flow switch is activated.

The fan will run and the pressure differential switch will be activated. This in turn will energise the electronic ignition control box.

The gas valve will be energised and the electrode will start to spark.

If a flame is detected during the ignition attempt period, (8-12 seconds) the sparking will cease and the gas valve will remain energised. The appliance will remain at a low gas rate for a period of approximately 2 minutes, if this gas rate is insufficient to raise the primary water temperature to the required level the gas rate will increase to the gas rate for c/h which was predetermined at the commissioning stage by an on-site adjustment of the potentiometer to suit the system requirements.

The temperature rise of the primary water is sensed by the thermistor on the main flow tube leaving the main heat exchanger.

As the temperature of the primary water approaches that set on the c/h temperature control the voltage to the modulator coil will decrease and thus lower the gas rate.

On reaching the set temperature the gas valve is de-energised and the burner is extinguished.

The appliance has an inbuilt delay timer and re-ignition will not be attempted for approximately 3 minutes.

Conversely a fall in temperature of the primary water will increase the voltage to the modulator coil and therefore increase the gas rate.

Constant monitoring of the temperature of the primary water by the thermistor will regulate the gas rate to maintain an average heat input.

When the appliance has reached temperature and the burner is off, the pump will continue to run to circulate the primary water around the c/h system.

If supply to the appliance is broken e.g. by a room thermostat or timeclock the burner is extinguished and the fan stops, but the pump will continue to run until the primary water temperature is below 75°C.

Should there be a restriction in the heating circuit reducing the flow rate to below 350 l/hour (1.28 gpm) the flow switch will deactivate and de-energise the gas valve.

Self Diagnostic Neon Lights

The 5 neon lights on the appliance control panel serve to identify some faults that may occur within the appliance.

The single neon at the top will normally show green if the appliance is 'on' and no faults are apparent. Should this neon change to red and start flashing it indicates a fault. During an ignition attempt this neon may show red for 1-2 seconds this is quiet normal.

The flashing red light will be accompanied by the illumination of one or more of the 4 neons just below it.

Each of the neons indicate a particular fault as given below and will continue to be illuminated until the fault is remedied or the appliance is switched off.



Insufficient system water pressure or poor flow in system. (top up system pressure or call engineer)



Problem with Fan/Flue. (call service engineer)



Overheat. (press overheat reset button if overheat trips again call engineer)



Lockout. (turn on/off /mode selector switch to reset position for approx. 5 seconds)

FAULT FINDING GUIDES

On the following pages are the fault finding guides, be sure to read the notes below before beginning any fault finding

NOTES:

1. To ensure correct fault diagnosis it is important that these guides are carried out in the set order.
2. Check the electrical supply polarity is correct before carrying out fault finding (lockout will occur if the polarity is reversed).
3. To ensure that external controls (if fitted) do not interfere with fault finding, disconnect the wires from terminals 1 & 3 (labelling them in the process to ensure correct reconnection) and provide a solid link between 1 & 3.
4. In the guides the abbreviation vDC = a DC voltage of between 24 & 28 volts.
5. The correct resistance of the NTC sensor is between 1 & 30 Kohms. (e.g. at 20°C a resistance of approx. 12 Kohms)

CHECKING OPERATION OF ELECTRONIC CONTROL BOX

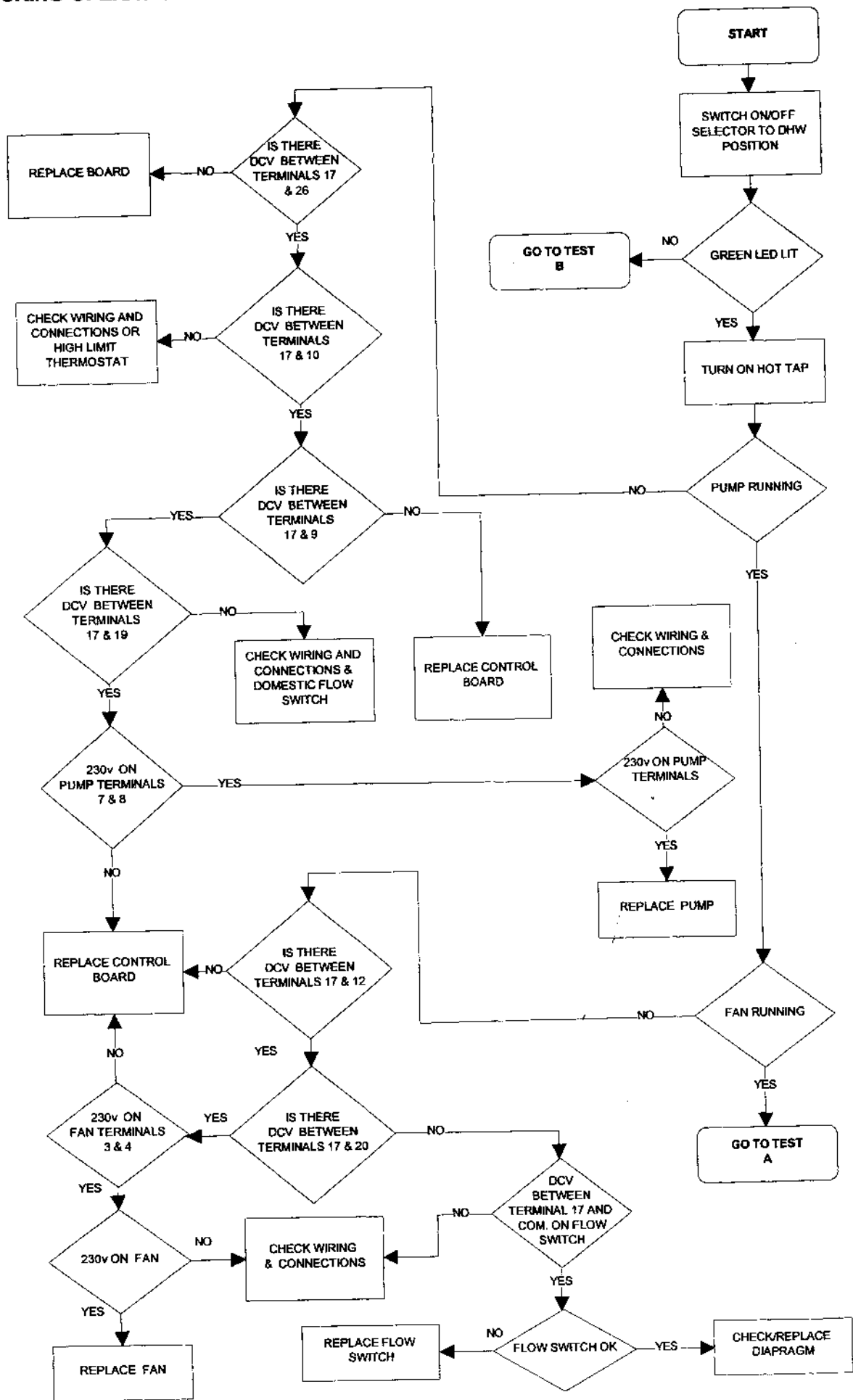

TEST B

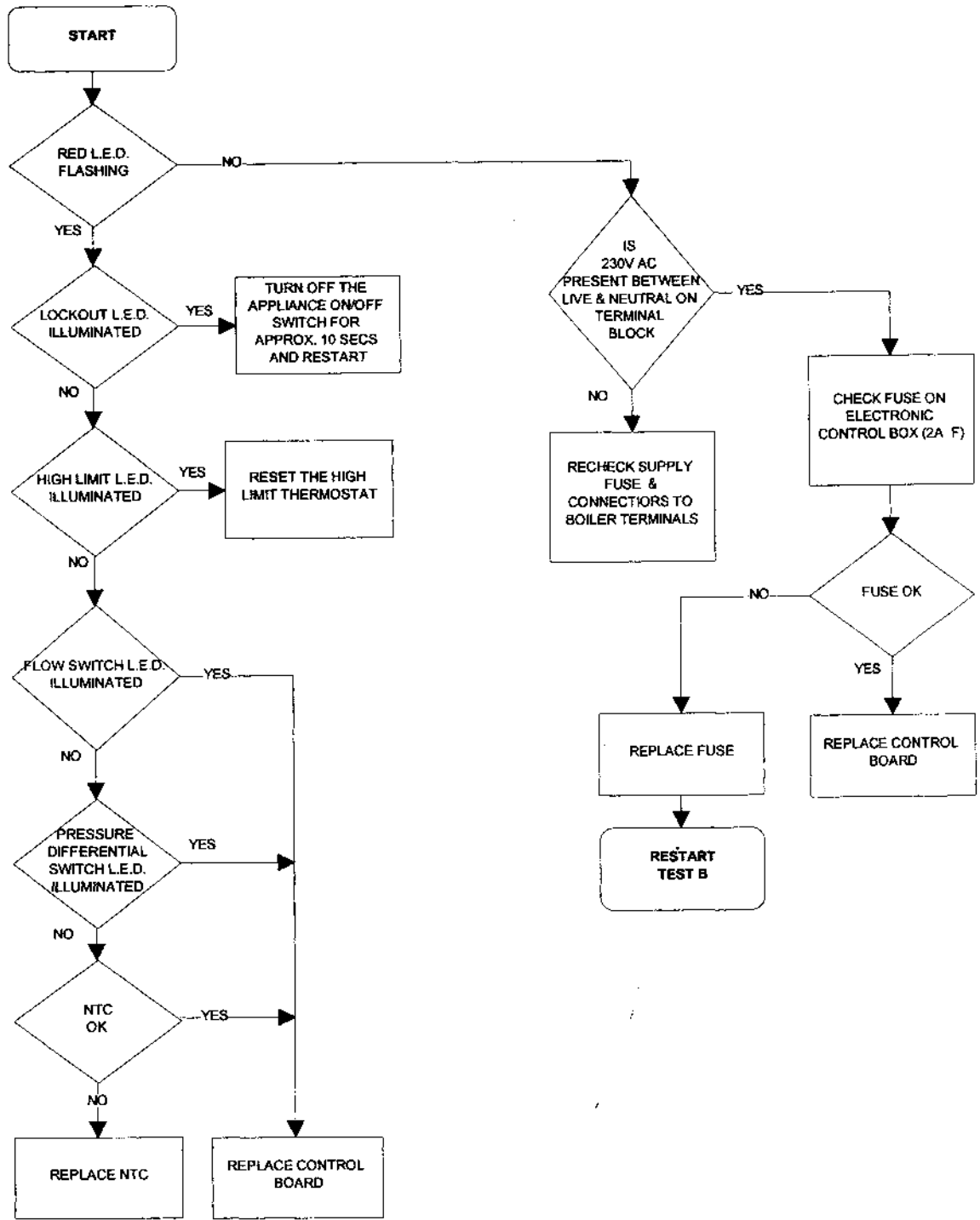

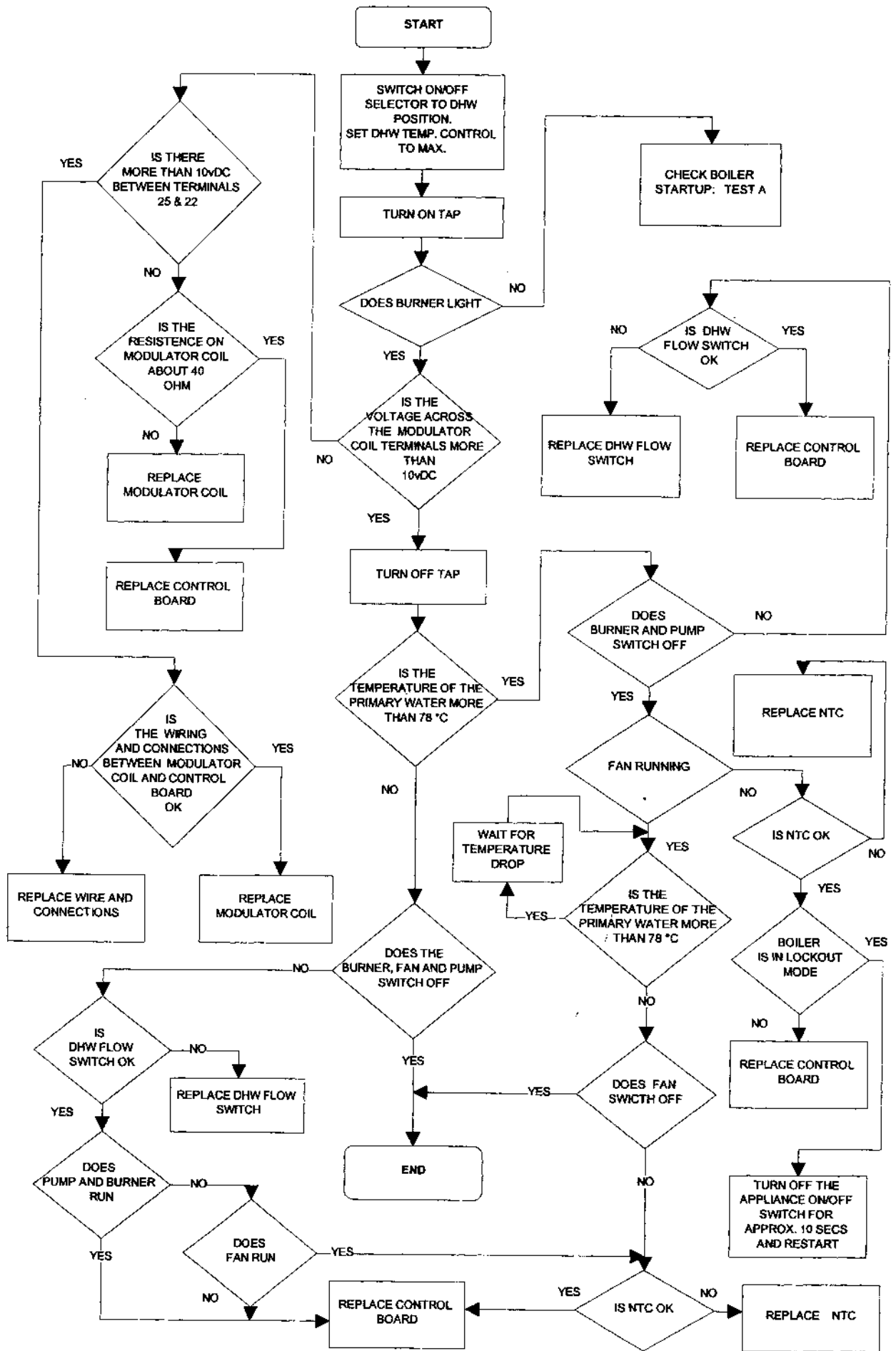

CHECKING CONTROLS IN C/H MODE

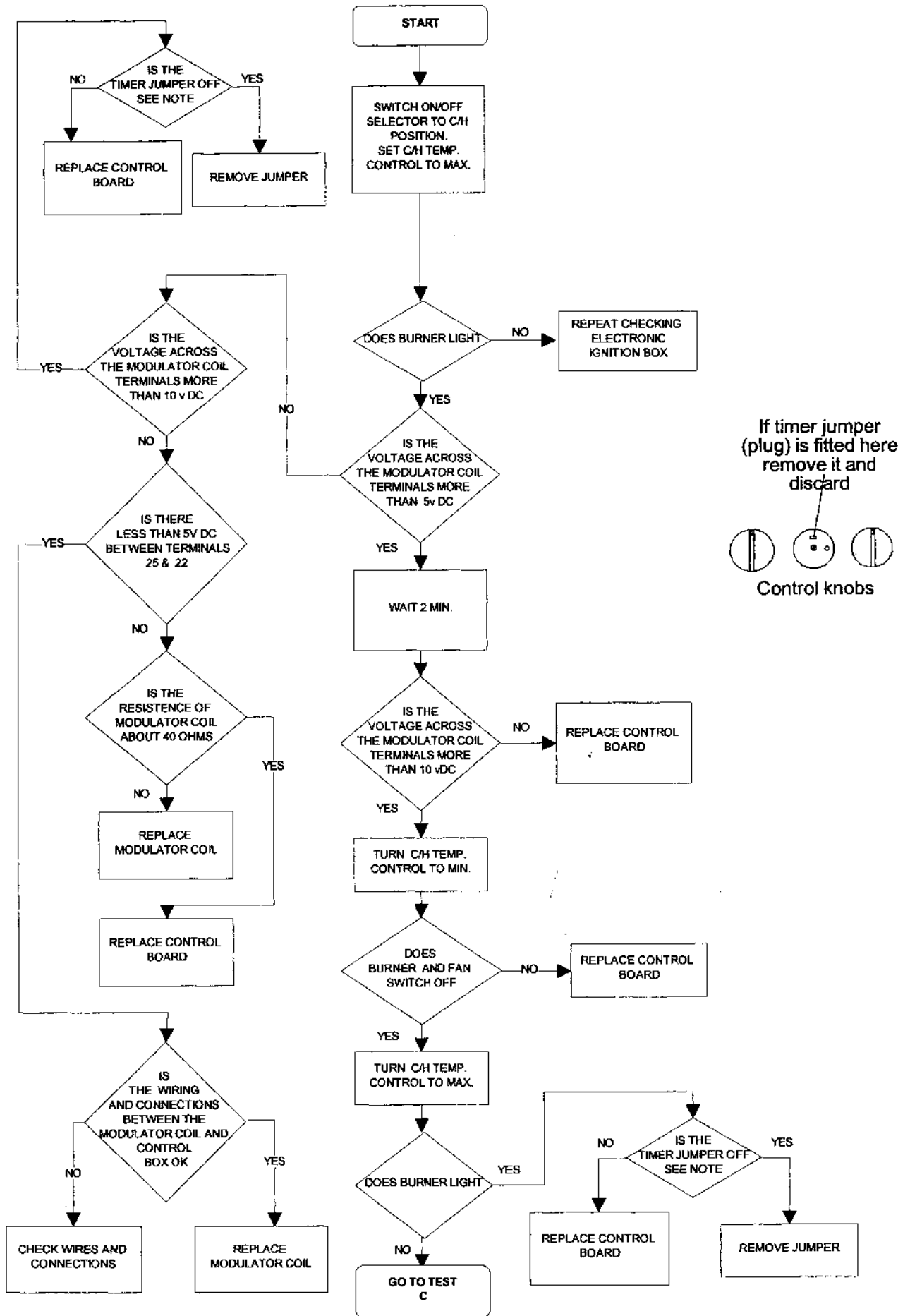

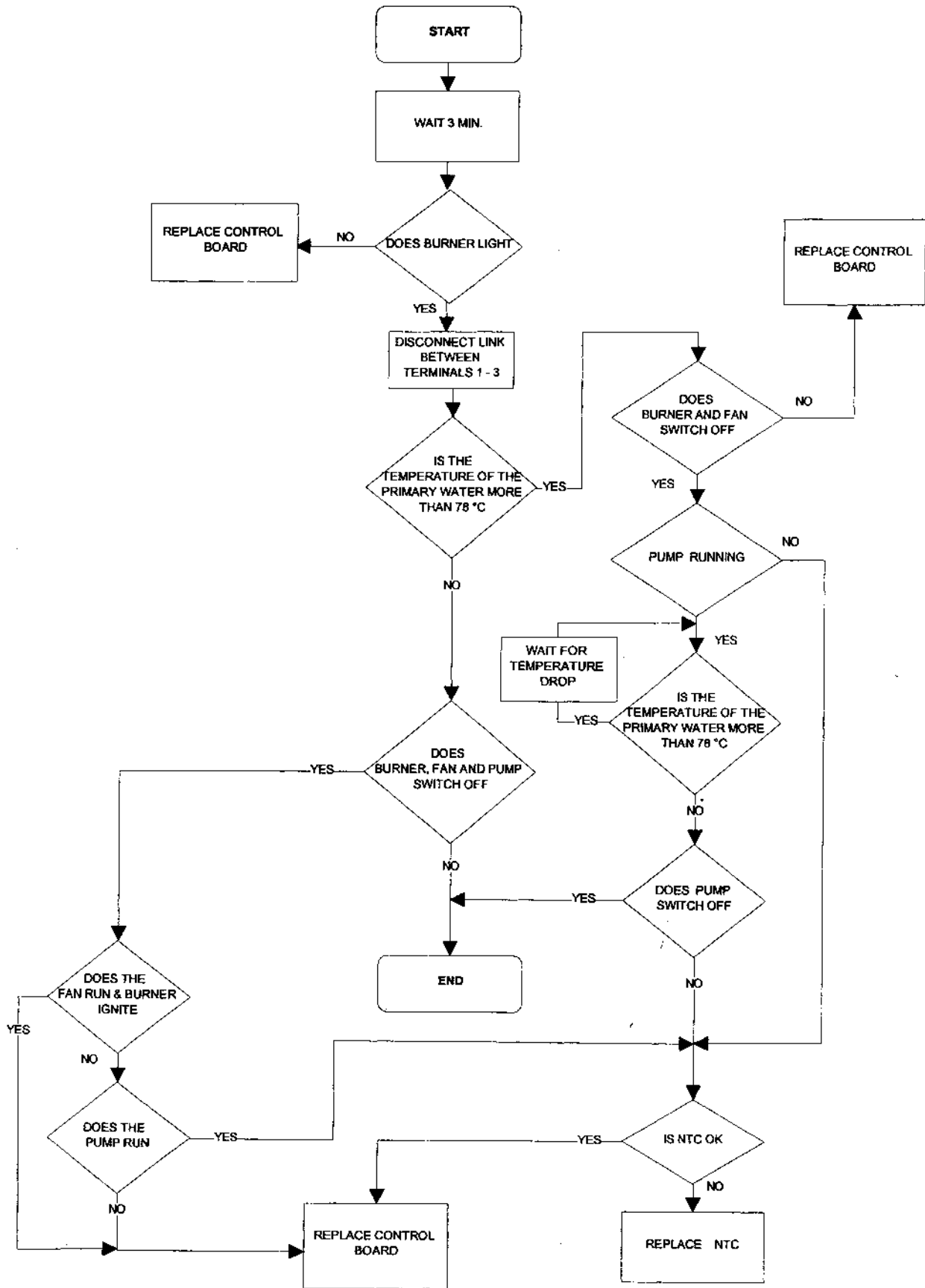

SECTION 10 APPENDIX

Instructions for (A) Fitting Vokera 24 Hour Time Switch (Part No.032 G.C. No. 301 110) and Vokera Digital 7 Day Time Switch (Part No. 05 G.C. No. 301 109)
 (B) Wiring to external Time Switches, Room Thermostats and Frost Thermostat.
 (C) Wiring for 'S' Plan Installations.

A. Installation of the Vokera time switches (24 Hr and 7Day)

Remove the clock aperture blanking plate (1) fig.1 by removing the securing screws and pulling the plate out.

Remove the clock from it's box.

Wire the clock as shown in fig. 4.

Insert the clock into the aperture from the back of the control panel, and secure the clock to the front control panel using the four screws provided. (See fig.2)

Connect the other ends of the wires as detailed below. (fig.3)

White/Red: Connect to terminal marked L.

Blue: Connect to terminal marked N.

Red/Black: Connect to terminal marked 1.

FOR INTERNAL CLOCK ONLY

White: Connect to terminal marked 3, (remove link wire connected between terminals 1-3.)

FOR INTERNAL CLOCK AND ROOM STAT

White: Connect to terminal marked 2, remove link between terminals 1-3 and connect room thermostat between terminals 2 & 3.

ROOM THERMOSTAT ONLY

Remove the loop between terminals 1 & 3 and connect room thermostat as fig 5.

NOTE:

THE CONTROL/SWITCHING CIRCUIT FOR THE TIME CLOCK AND OR ROOM THERMOSTAT IS LOW VOLTAGE 24 v.

The loop between terminals 1 & 3 remains when no external or internal control is used.

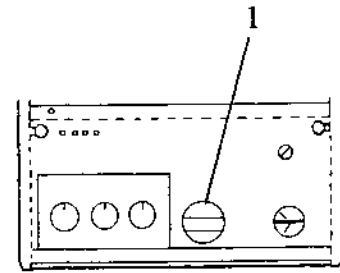

Fig. 1

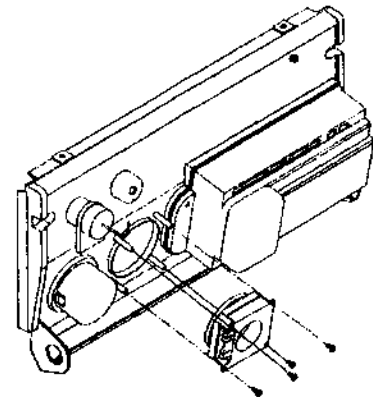

Fig. 2

230v ~ Output for Time Clock Motor Supply Only

Terminals 1 to 4 are 24v for control circuits only.

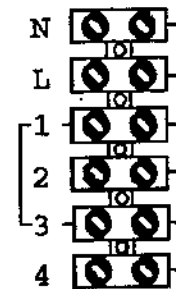

Fig. 3

Vokera Room Thermostat

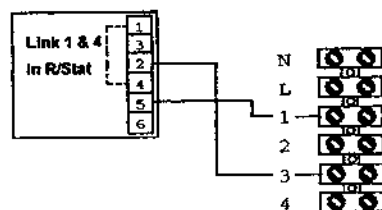

Fig. 5

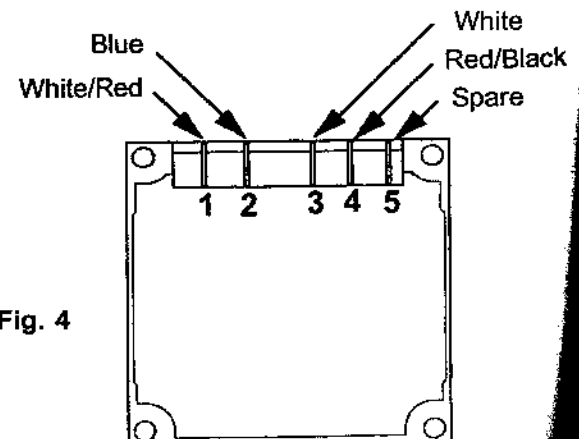
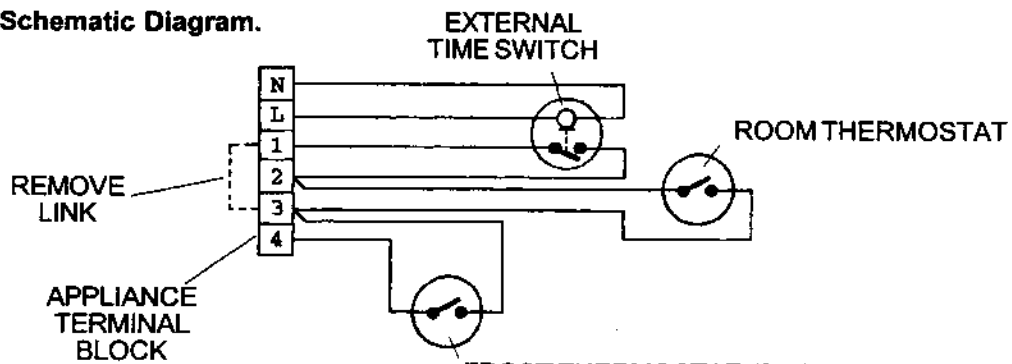



Fig. 4

B. Wiring to External Time Switches and Thermostats.

(i) General Schematic Diagram.



NOTE:
TERMINALS 1 - 4 ARE LOW VOLTAGE

FROST THERMOSTAT IF REQUIRED. OVER RIDES OTHER CONTROLS TO BRING APPLIANCE ON IN HEATING MODE IF SPACE TEMPERATURE FALLS BELOW THAT SET ON FROST STAT. (MODE SELECTOR MUST BE SET AT EITHER  or 

(ii) ACL Time Switch and Vokera Room Thermostat

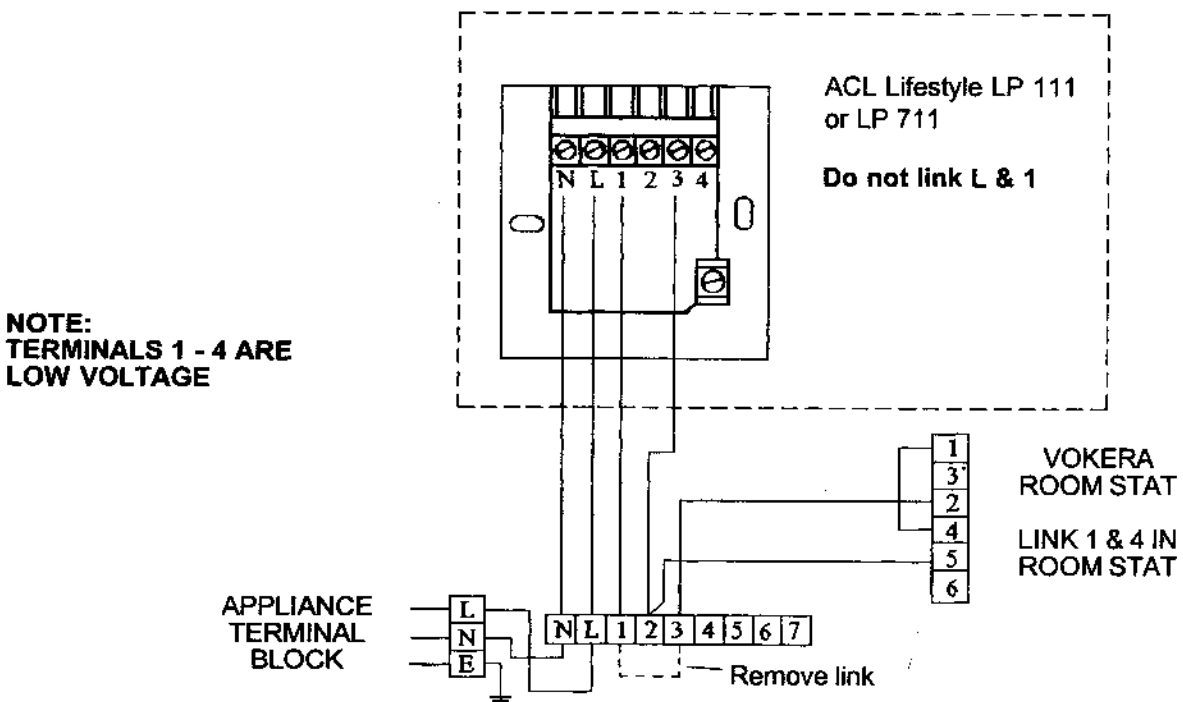

(iii) Randall Time Switch and Vokera Room Thermostat.

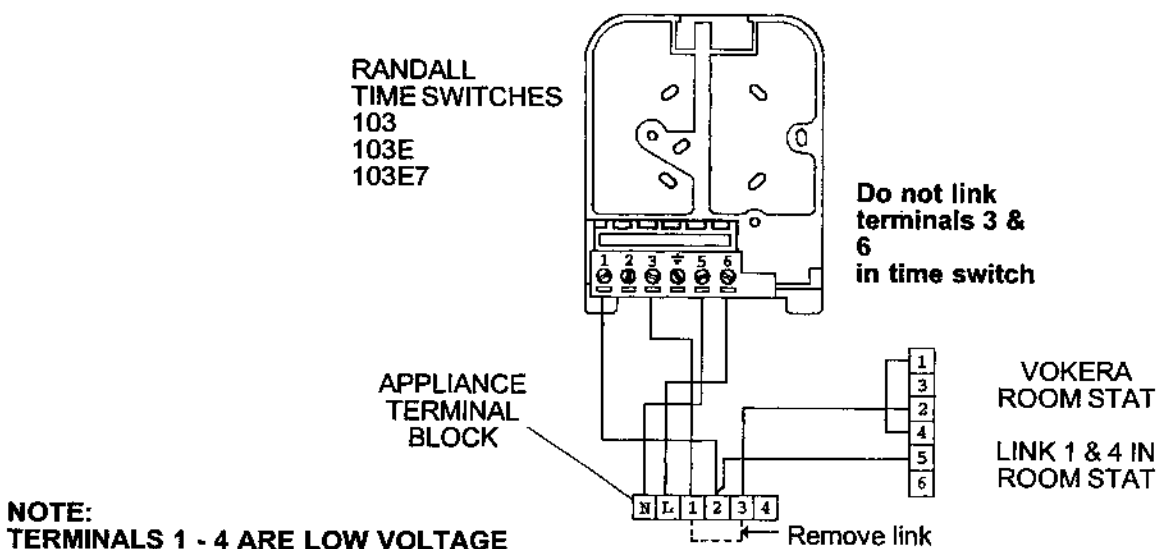

C. Wiring for 'S' Plan Installations.

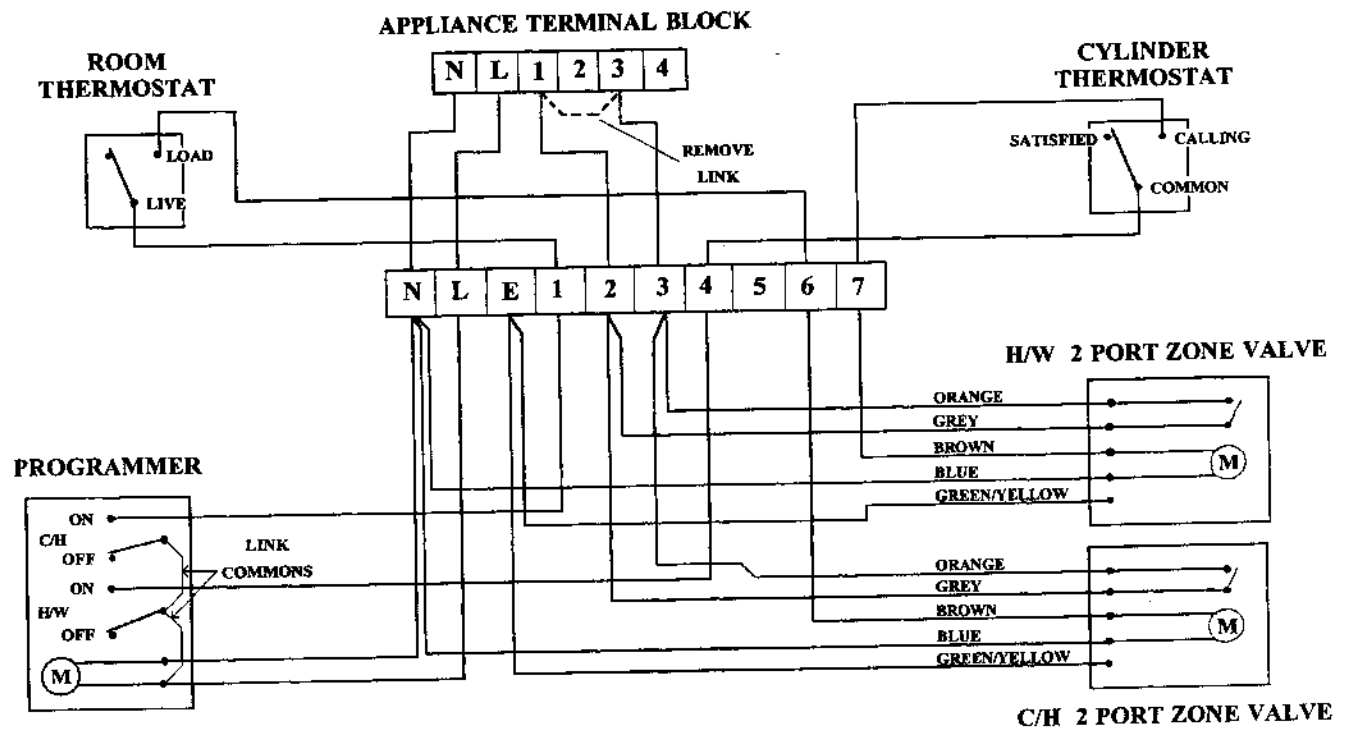

IMPORTANT:
 THE AUXILIARY SWITCHES OF THE MOTORISED VALVES ARE SWITCHING 24V BETWEEN TERMINALS 1 & 3 OF THE APPLIANCE AND CARE SHOULD BE TAKEN WHEN WIRING THE 'S' PLAN

NOTE: 'Y' PLAN INSTALLATIONS ARE NOT RECOMMENDED.

EXPLODED DIAGRAMS

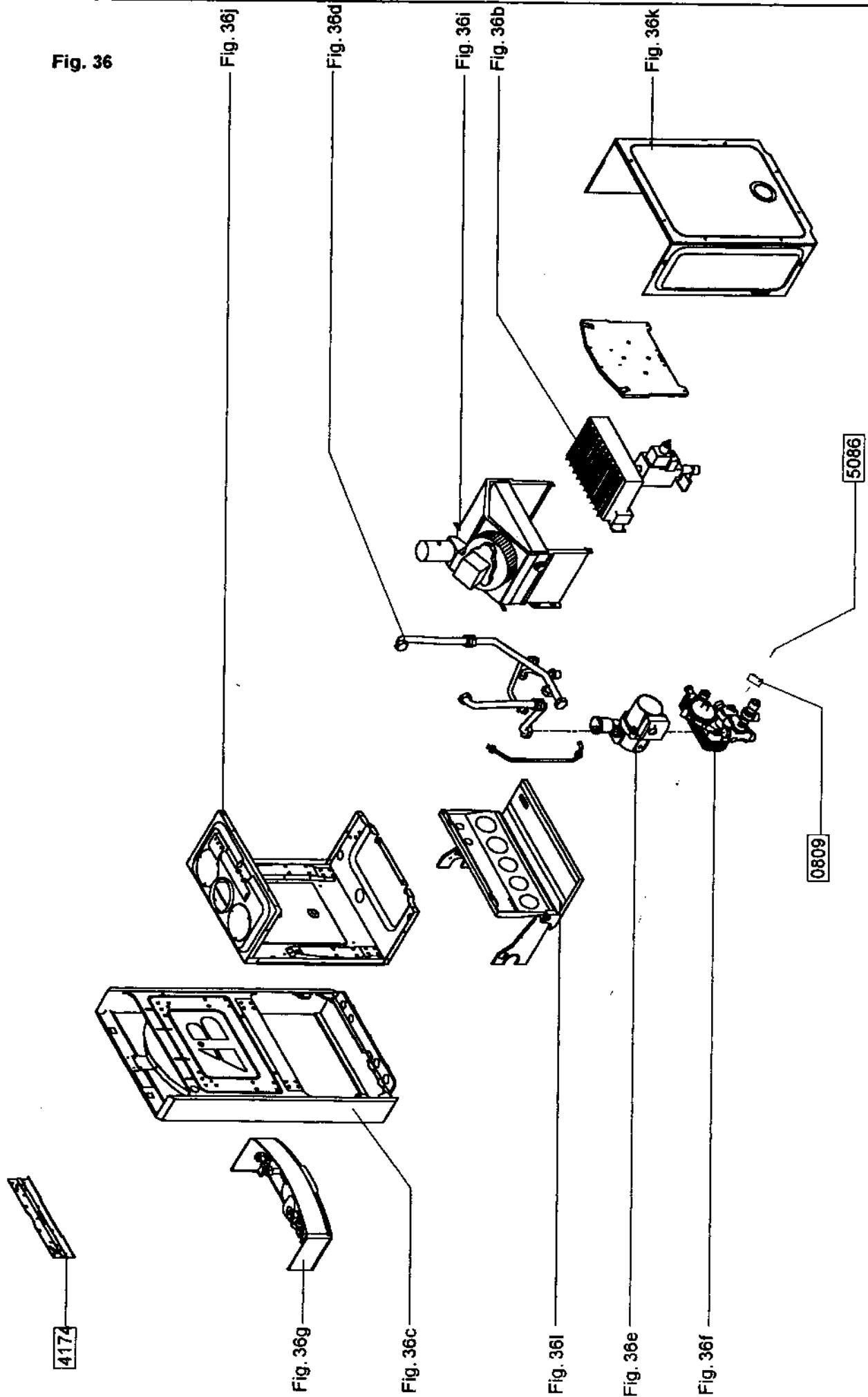

Fig. 36B Gas Assembly

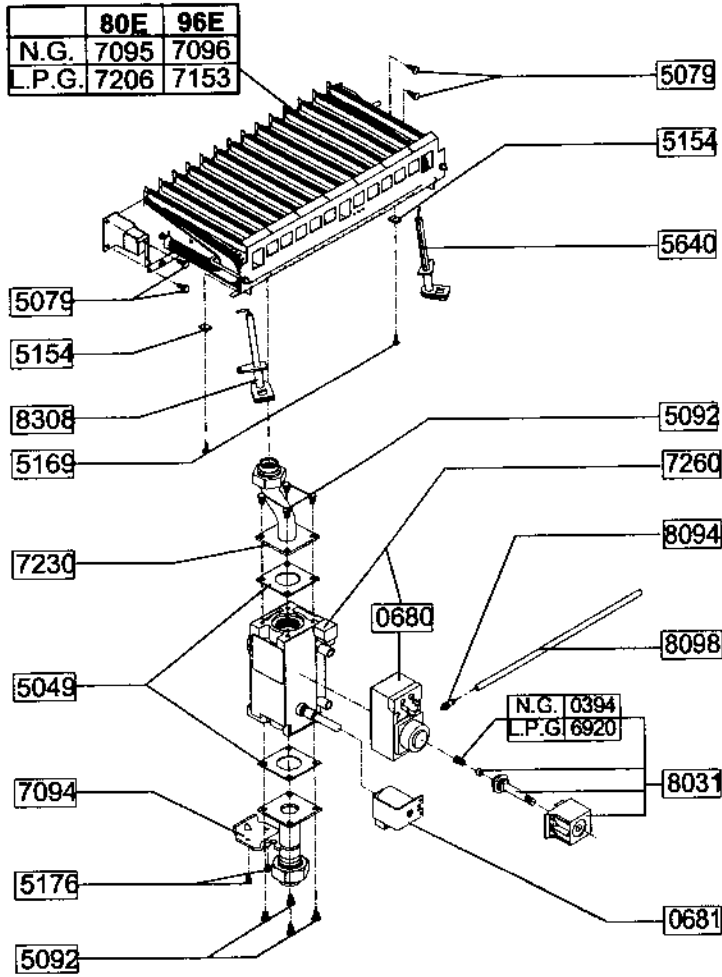

Fig. 36C Main Frame & Expansion Vessel

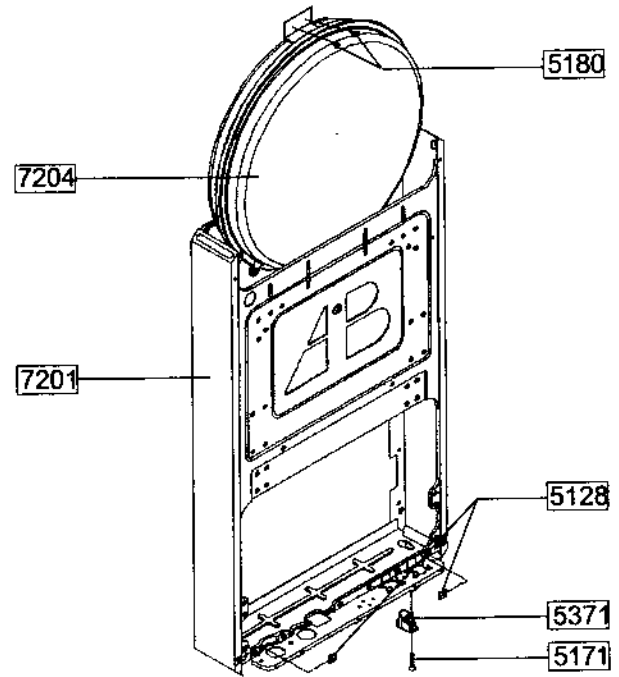

Fig. 36D Connecting Pipes

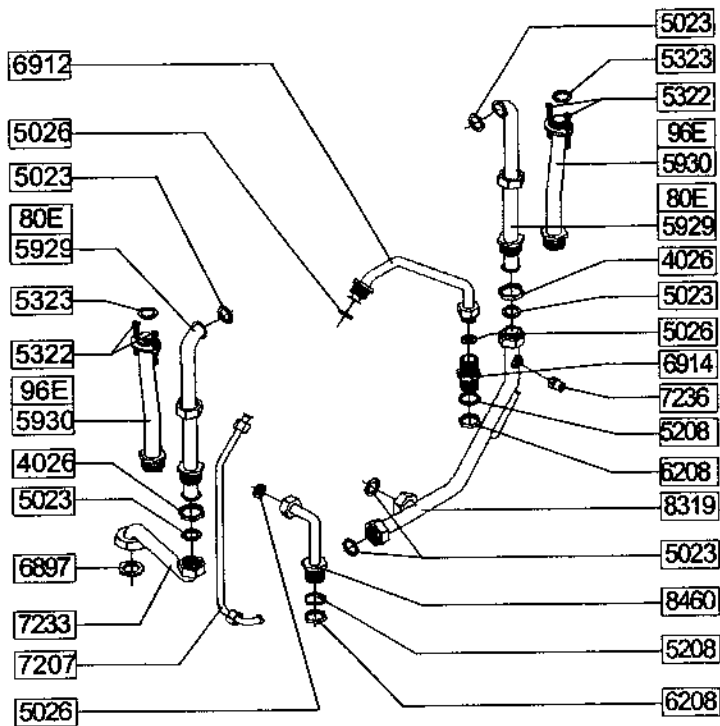

Fig. 36E Circulation Pump Grundfos 15-50 AO

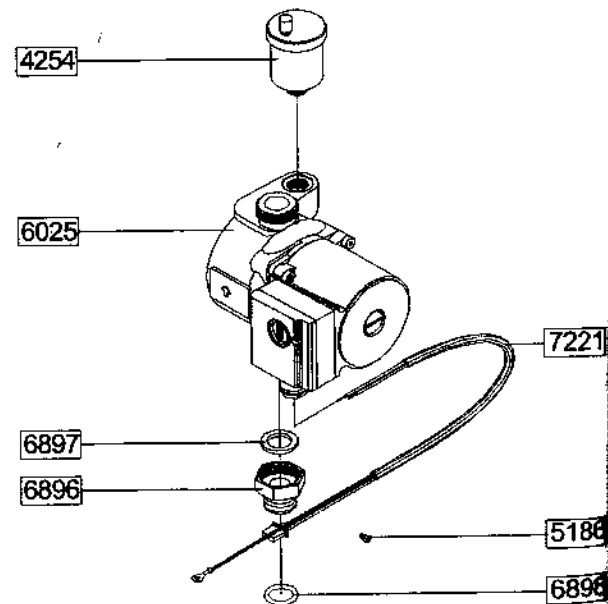

Fig. 36F Hydraulic Assembly

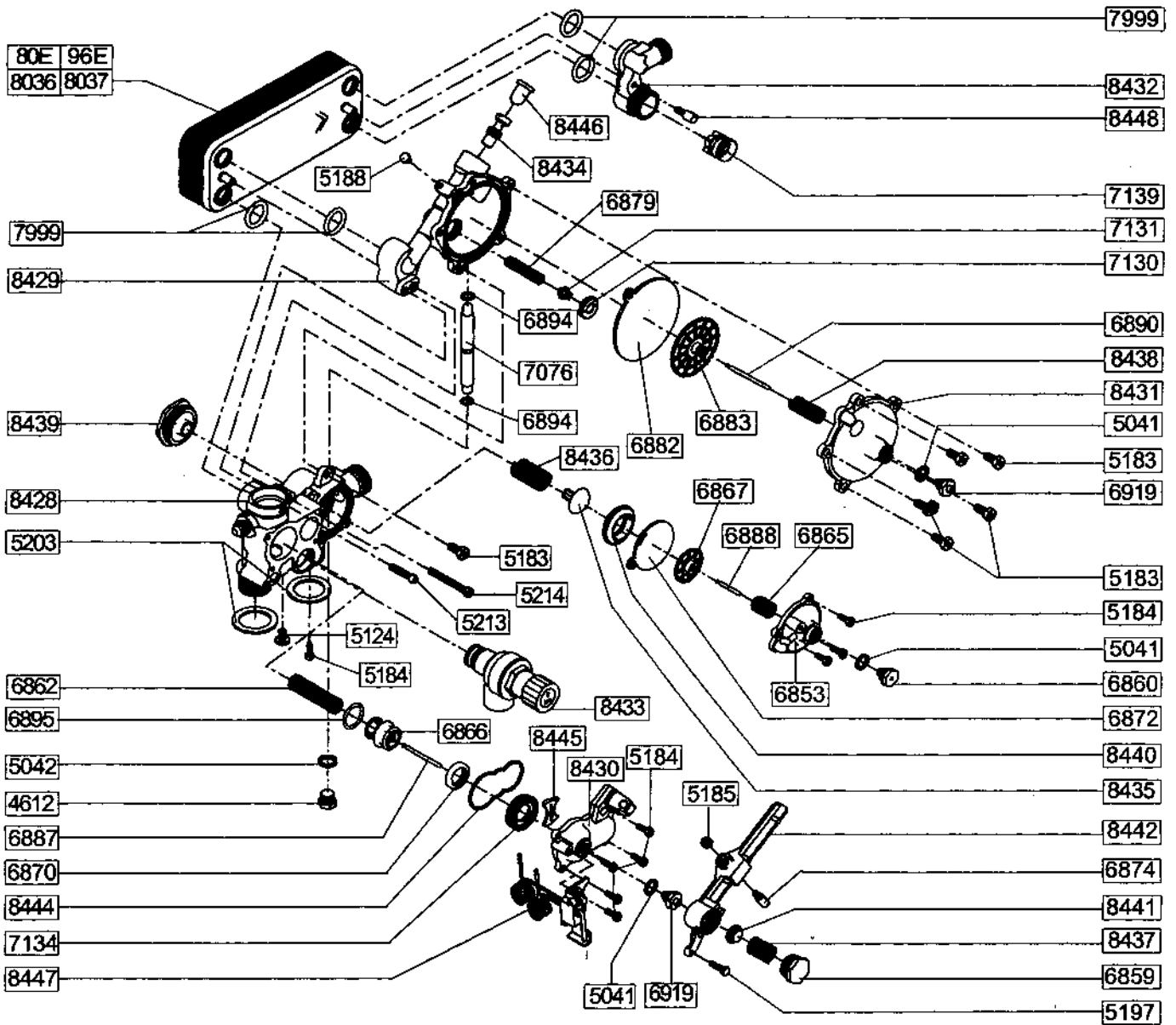

Fig. 36G Valves and Valve Cover

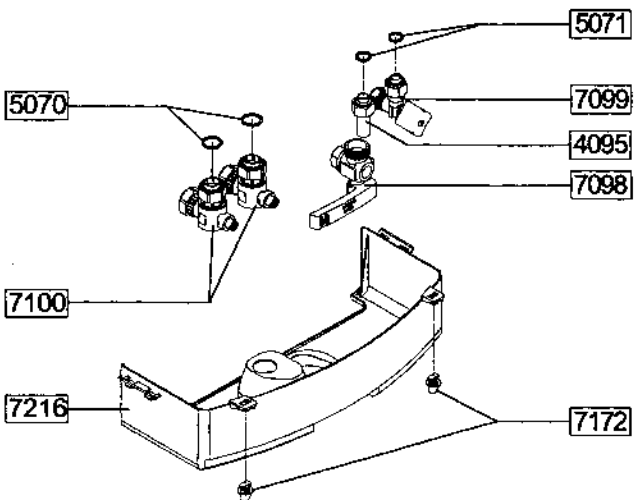
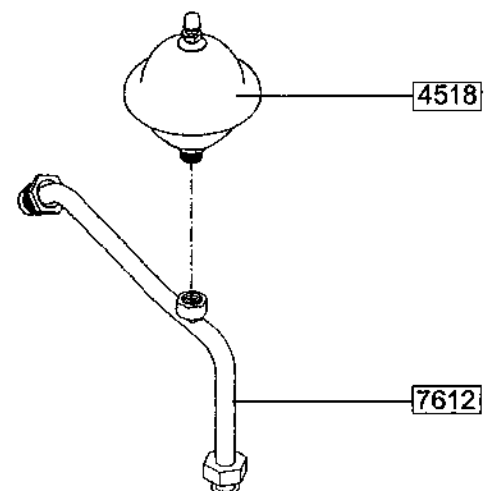

Fig. 36H Expansion Vessel Kit (Optional)



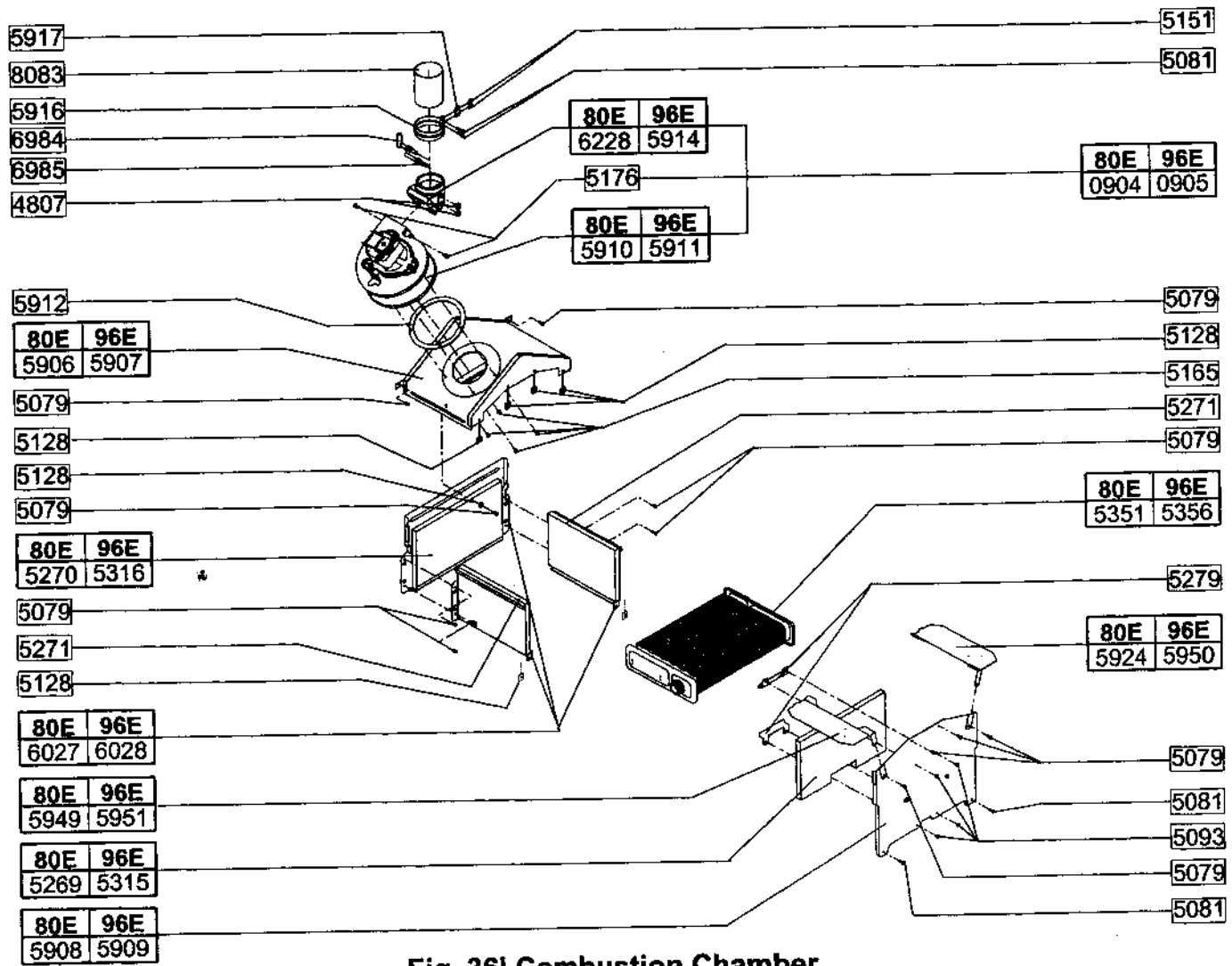

Fig. 36I Combustion Chamber

Fig. 36J Sealed Case

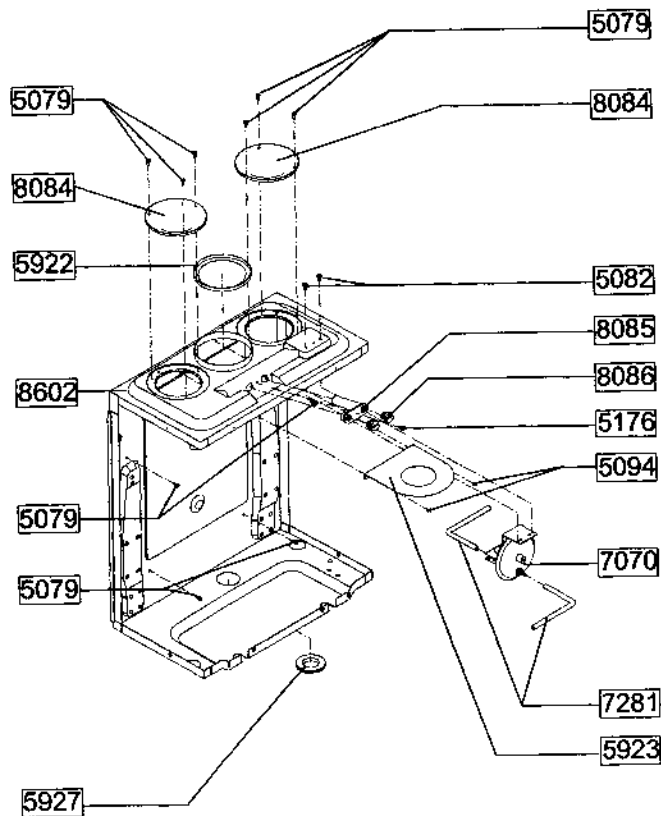

Fig. 36K Cover

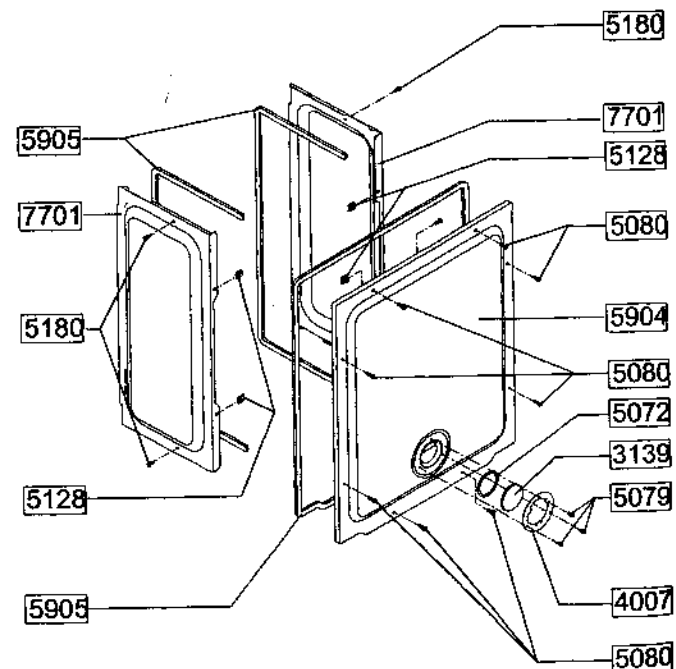

Fig. 36L Front Panel

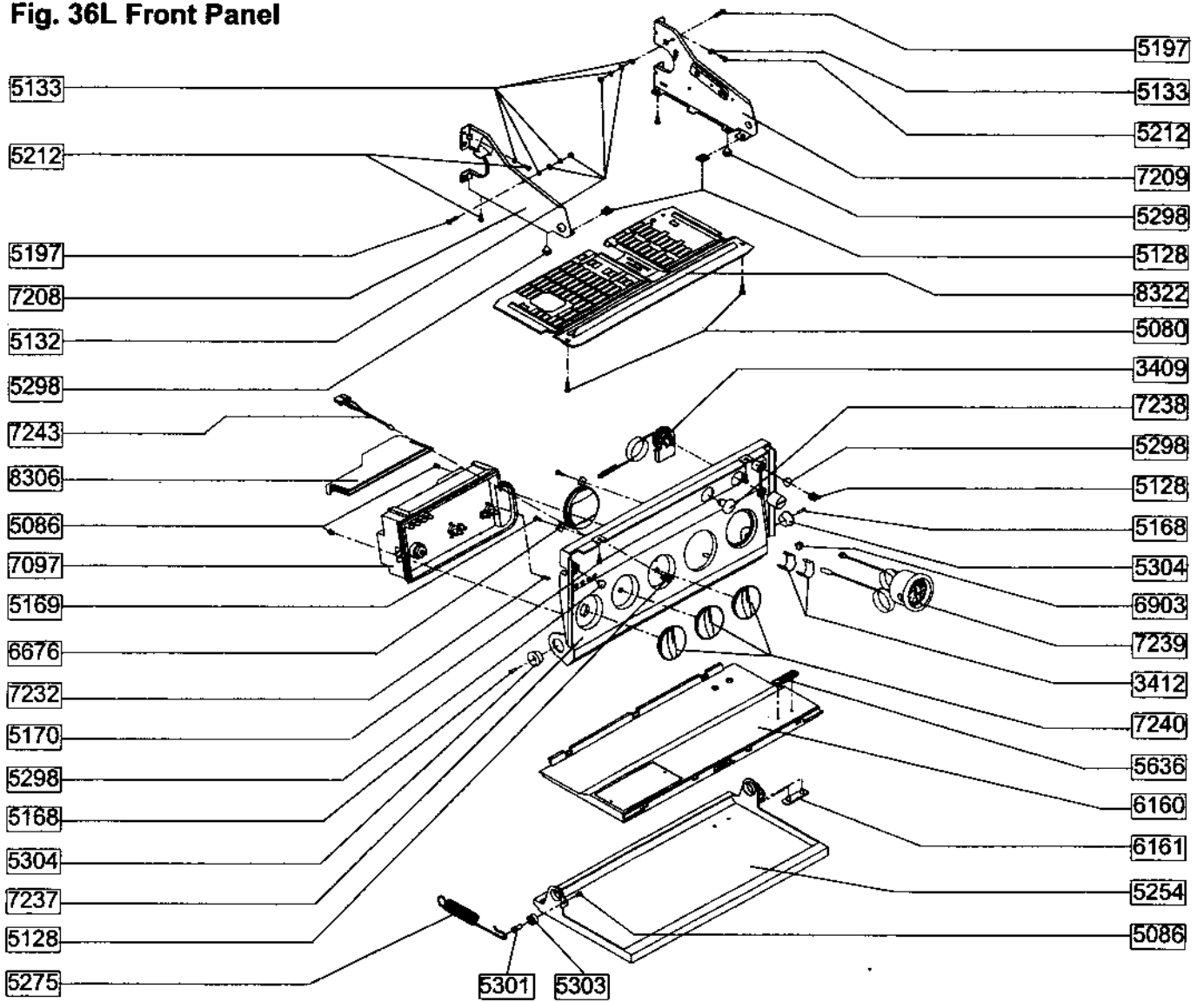
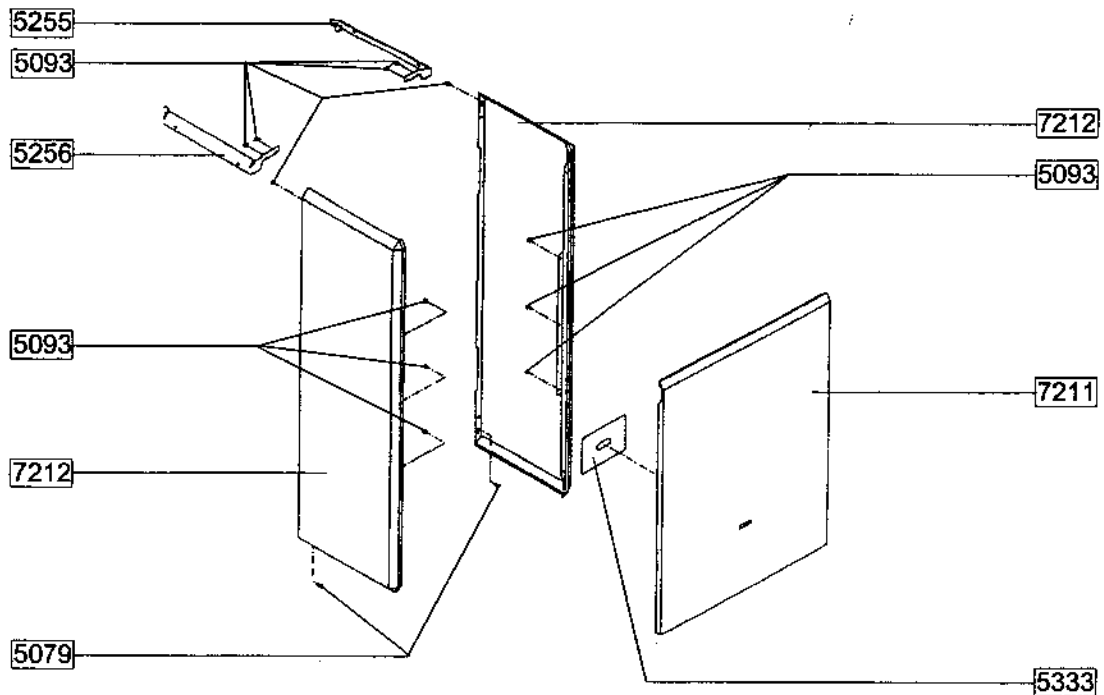

Fig. 36M Outer Casing



SHORT SPARE PARTS LIST

REFER TO FIG. 36

Code	G.C. No.	Description
0680	301 222	Operator
0681	301 224	Solenoid
4254	333 722	Auto Air Vent
5351	301 085	Main Heat Exchanger (80E)
5356	301 023	Main Heat Exchanger (96E)
5640	301 034	Spark Electrode
5853	301 221	Sense Electrode
6025	379 279	Grundfos UPS 15-50 AO Pump
6491	301 242	Fan (80E)
6492	301 213	Fan (96E)
6872	301 188	Flow Diaphragm
6882	301 180	Domestic Diaphragm
7070	379 736	Pressure Differential Switch
7095	301 217	Main Burner (N.G.)
7096	301 219	Main Burner (N.G.)
7097	301 239	Ignition Control Box
7098	301 216	Gas Service Cock
7099	301 214	Cold Water Inlet Service Cock (Adjustable)
7204	301 145	Expansion Vessel
7236	301 227	Thermistor
7239	301 210	Combined Pressure & Temperature Gauge
7260	379 296	Gas Valve Complete
8031	301 256	Modulator Coil Complete
8036	301 335	Domestic Heat Exchanger (80E)
8037	301 336	Domestic Heat Exchanger (96E)
8428	301 342	Heating Flow & Return Manifold
8429	301 339	Domestic Manifold Section
8433	301 343	Safety Valve
8447	301 347	D.H.W. Microswitch

FUNCTIONAL FLOW DIAGRAM General Layout

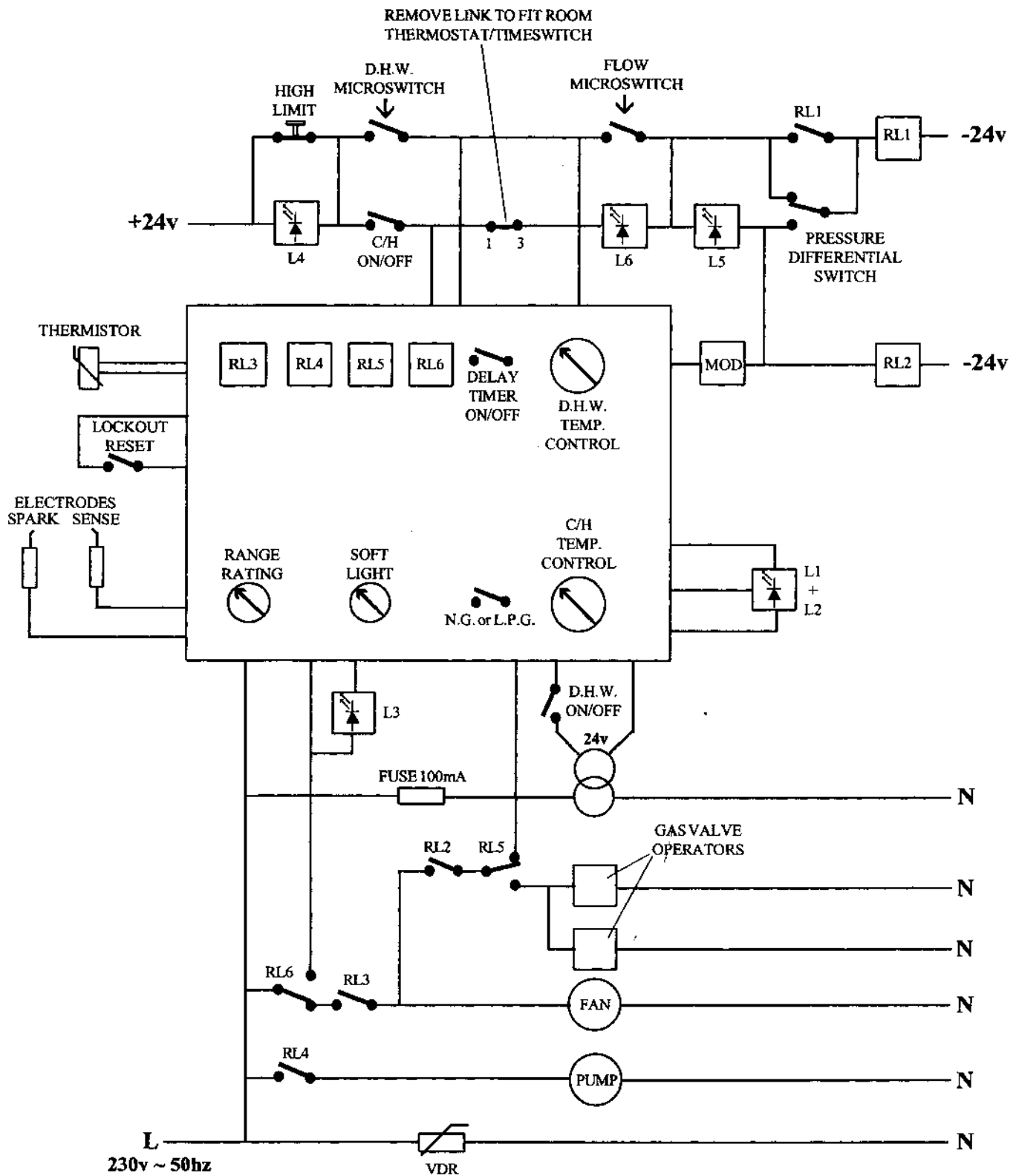
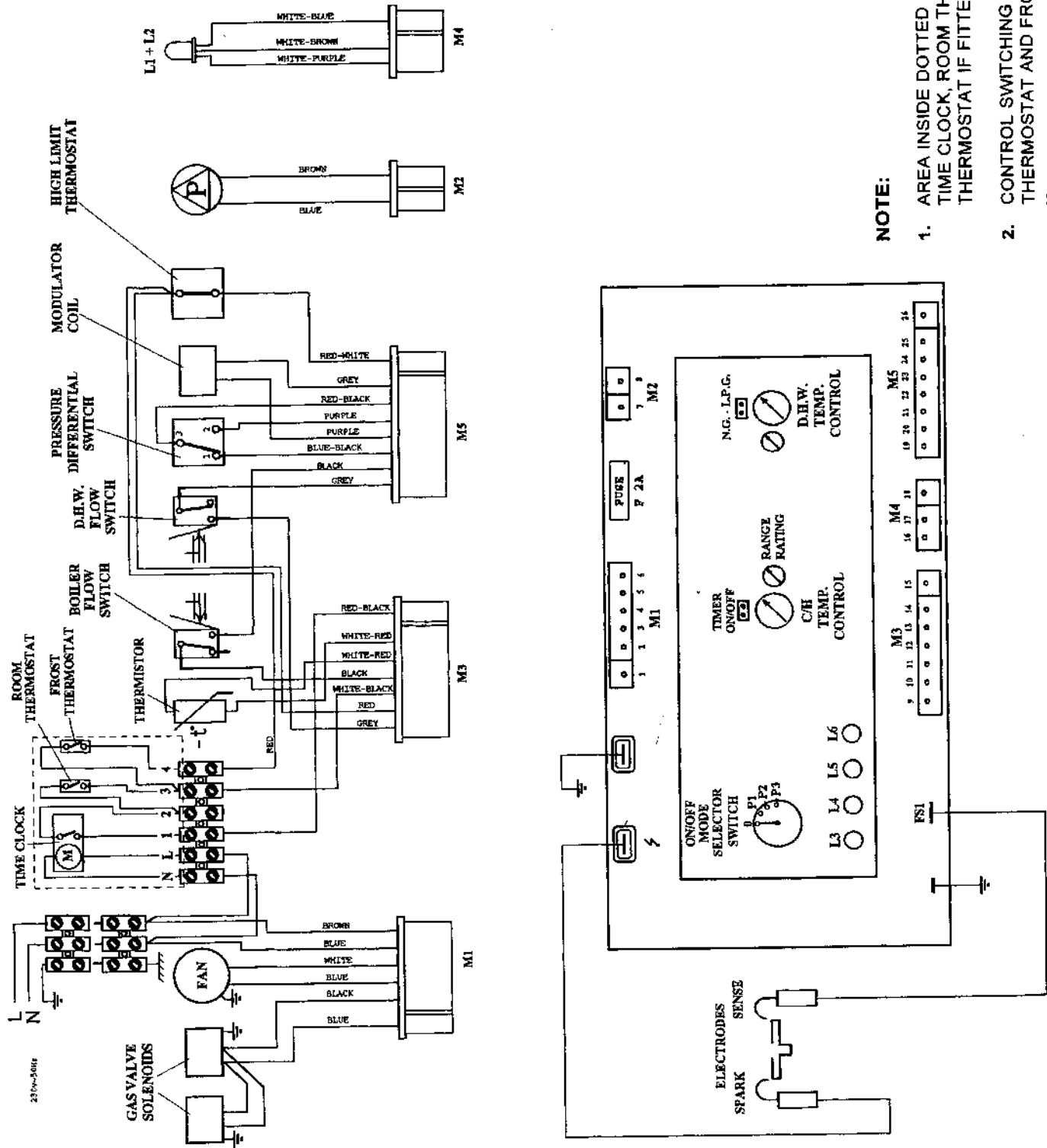

Fig. 37

GENERAL LAYOUT OF WIRING FROM PRINTED CIRCUIT BOARD



- NOTE:**
1. AREA INSIDE DOTTED LINE SHOWS WIRING OF TIME CLOCK, ROOM THERMOSTAT AND FROST THERMOSTAT IF FITTED.
 2. CONTROL SWITCHING OF TIME CLOCK, ROOM THERMOSTAT AND FROST THERMOSTAT IS 24 V.

Fig. 38

ILLUSTRATED WIRING DIAGRAM

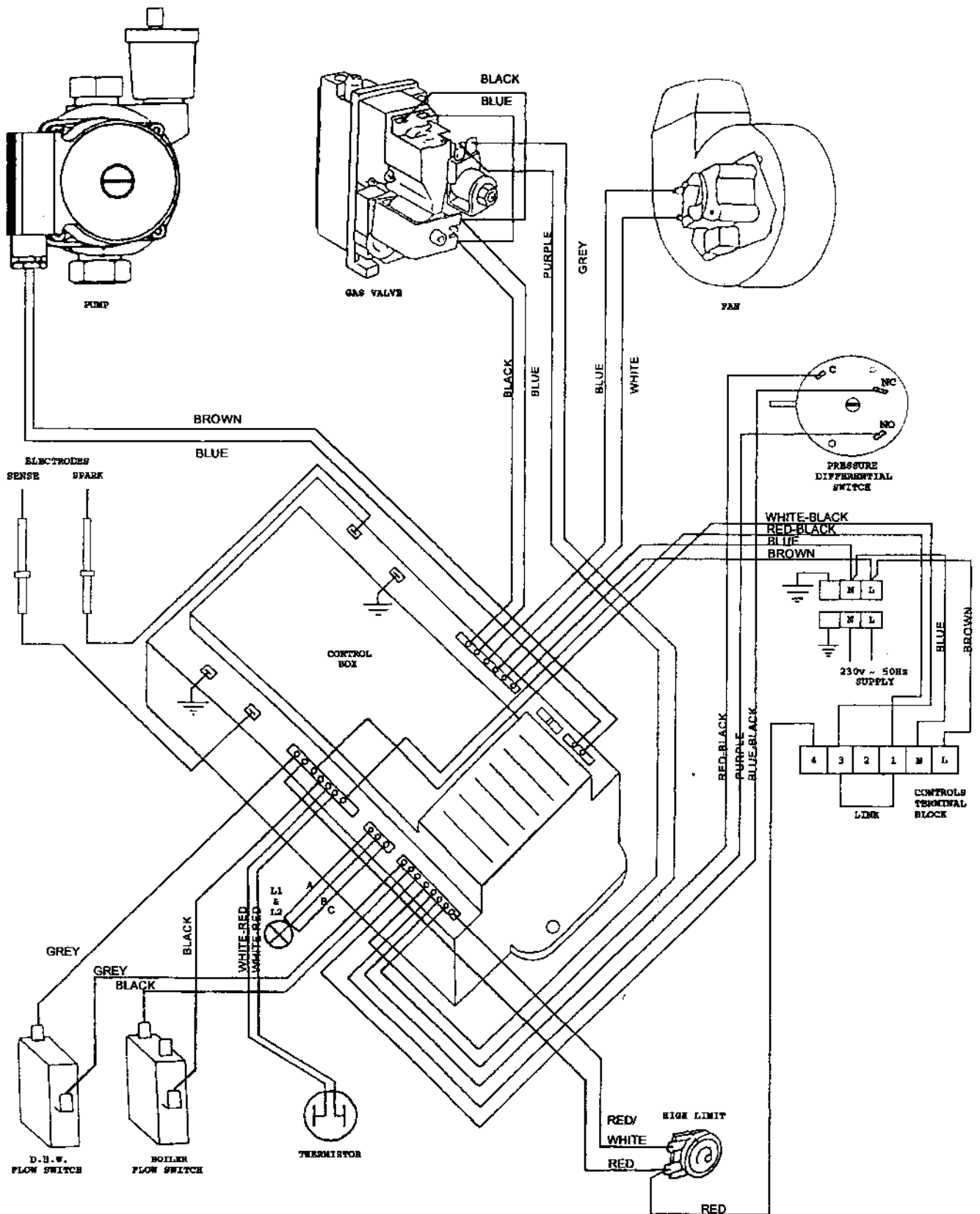

A = WHITE - PURPLE
 B = WHITE - BROWN
 C = WHITE - BLUE

Fig. 39

PRELIMINARY ELECTRICAL SYSTEM CHECKS

A. EARTH CONTINUITY CHECK - appliance must be electrically disconnected - meter set on Ω (ohms) x 1 scale and adjust zero if necessary.

a) Test leads from any appliance earth point to earth pin on plug - resistance should be less than 0.1 Ω (ohm).

If the resistance is greater than 0.1 Ω (ohm) check all earth wires for continuity and all contacts clean and tight.

If resistance of earth is still greater than 0.1 Ω (ohm) then this should be reported to your supervisor.

B. SHORT CIRCUIT CHECK - appliance electrically disconnected, all switches ON (including stats) -

a) meter set on Ω (ohms) x 1 scale.

Test leads from L to N in appliance terminal strip/block - if meter reads 0 then there is a short circuit.

b) meter set on Ω (ohms) x 100 scale

Repeat test with leads from L to E. If meter reads less than ∞ (infinity) there is a fault.

NOTE - Should it be found that the fuse has failed but no fault is indicated - a detailed continuity check (i.e. by disconnecting and checking each component) is required to trace the faulty component. It is possible that a fault could occur as a result of local burning/ arcing but no fault could be found under test. However, a detailed visual inspection should reveal evidence of burning around the fault.

C. POLARITY CHECK

Appliance connected to mains supply and meter set on 300V ac scale. Test at appliance terminal strip:-

a) Test leads from L to N - meter reads approx 230V ac

b) Test leads from L to E (\neq) - meter reads approx 230V ac

c) Test leads from N to E (\neq) - meter reads from 0-15V ac*

Thus the terminal marked L is the live terminal. If the low* V ac reading is given on terminals other than N to E (\neq) there is an electrical fault.

Repeat the test at the appliance plug/inlet spur to check the wiring system up to the appliance and rectify any fault. If necessary repeat the test at the supply system socket/spur - if the fault also occurs at this stage then there is a house system fault which requires attention by the ELECTRICITY AUTHORITY. The customer should be warned not to use the appliance until this examination has been carried out.

D. RESISTANCE TO EARTH CHECK

Appliance must be disconnected from mains supply and meter set on Ω (ohms) x 100 scale. All switches, including stats, ON - Test leads from L to E - if meter reads other than infinity (∞) there is a fault which should be isolated. A detailed continuity check is required to trace the faulty component.

IMPORTANT - This series of checks are the first electrical checks to be carried out during a fault finding procedure. On completion of the service/fault finding task which has required the breaking and remaking of electrical connections then the checks - A. Earth Continuity. C. Polarity and D. Resistance to Earth - must be repeated.

SECTION 11 L.P.G. INSTRUCTIONS

11.1 Gas Rates (LPG)

	80E	96E
Min. Gas Rate	1.68 litres/h	1.63 litres/h
Max. Gas Rate	4.12 litres/h	4.85 litres/h

11.2 Burner Details (LPG)

	80E	96E
Main Burner	Polidoro NP12	Polidoro NP14
Main Burner Injectors	12 x 0.77	14 x 0.77
Burner Pressure Max. Rate	36.0 mbar	36.0 mbar
Burner Pressure Min. Rate C/H & DHW	5.5 mbar	5.2 mbar
Burner Pressure Soft Light	16.7 mbar	16.7 mbar

11.3 RELATED DOCUMENTS

BS 6891		1988	Low pressure installation pipes
BS 6798		1987	Boilers of rated input not exceeding 60kW
BS 5449	Part 1	1990	Forced circulation hot water systems
BS 5546		1990	Installation of gas hot water supplies for domestic purposes (2nd family gases)
BS 5440	Part 1	1990	Flues
BS 5482	Part 1	1994	Domestic Butane & Propane Gas burners in permanent dwellings

11.4 GAS SUPPLY

A gas supply should be connected to the boiler by a competent L.P.G. installer and should be of sufficient size to supply the boiler at its maximum output.

An existing supply should be checked by the installer or L.P.G. supplier to ensure that it can deal with the rate of gas supply required for all the appliances when they are in use at the same time.

11.5 GAS SUPPLY INSTALLATION

11.5.1 Inspect the entire installation including the meter, test for soundness and purge.

11.6 CHECK BURNER PRESSURE

11.6.1 The heat inputs for high and low gas rates are factory set to the maximum values given in section 11.2 but it is necessary to check/adjust this when commissioning the appliance.

11.6.2 The maximum heat input may be reduced by a simple adjustment to suit the system load. This in no way affects the appliance maximum which is always obtained in the domestic hot water mode.

11.6.3 Turn off the main electrical supply. Gain access to the interior as instructed in clause 5.7.2.

11.6.4 Locate the main burner pressure test point fig. 20 and slacken the screw half a turn in an anti clockwise direction. Attach a suitable pressure gauge. Turn on electricity supply and fully open a domestic hot water tap to operate boiler in dhw mode. Adjust hot water control knob to it's maximum setting.

11.6.5 The pressure reading for maximum output should be :

80E

36.0mbar 14.2in. w.g.

(Plus or minus 3.6mbar/1.4in. w.g.)

96E

36.0mbar 14.2in. w.g.

(Plus or minus 3.6mbar/1.4in. w.g.)

If the pressure is wrong it should be adjusted as instructed in clause 8.24. (N.B. Whenever the maximum rate is adjusted check and adjust the minimum rate too).

- 11.6.6** Reduce the domestic water flow rate to approximately 3-4 litres/min, turn the domestic control knob slowly to minimum the boiler output will reduce to the minimum setting. If low flame cannot be established in this way, turn off the electricity supply, remove the modulator coil retaining clip and slide the modulator coil off the brass rod. Switch on the electricity supply, the boiler will now light at the minimum setting.
- 11.6.7** When low flame is established the pressure reading should be :
80E
 5.5mbar/2.2in. wg
 (Plus or minus 0.5mbar/0.2in. wg)
96E
 5.2mbar/2.0in. wg
 (Plus or minus 0.5mbar/0.2in. wg)
 If it is different adjustment should be made in accordance with the instructions in clause 8.24.
- 11.6.8** If the modulator coil was removed to check the minimum setting, turn off the electricity supply and replace the modulator coil.

11.7

Setting the Maximum Rate for Central Heating (Range Rating)

Refer to fig. 40 to determine the pressure for the heating output required. Turn on the heating with the control knob set at maximum, wait for the burner to reach main flame. Pull off the heating control knob, use a small screwdriver to adjust the potentiometer fig. 21 until the required pressure is indicated on the gauge. Once this pressure has been fixed it should be indelibly recorded on the label provided and affixed next to the data badge. This is to ensure that the burner can be reset when any service operation involves alteration of burner settings.

Fig. 40

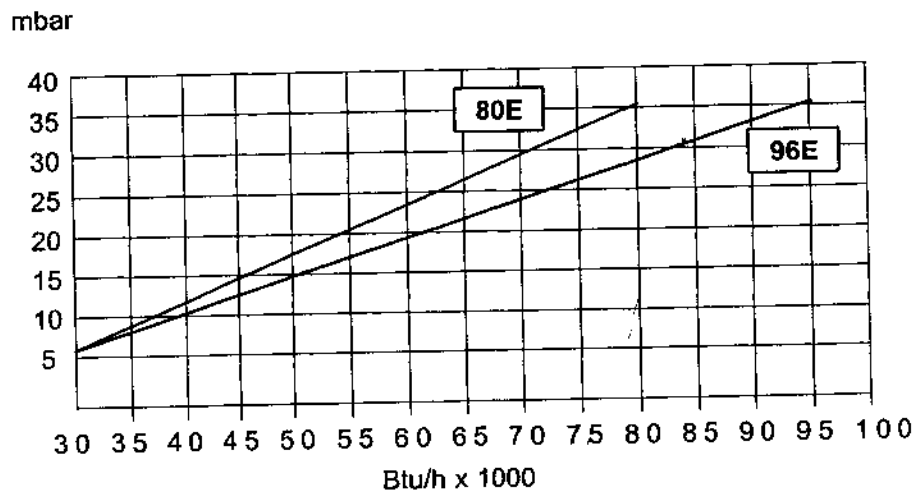

4

A series of horizontal lines for writing, consisting of 25 evenly spaced lines across the page.





Vokèra Ltd.

4th Floor, Catherine House, Boundary Way, Hemel Hempstead, Herts, HP2 7RP

Email: enquiries@vokera.co.uk Web: www.vokera.co.uk
General Enquiries - Tel: 01442 281400 Fax: 01442 281460
Technical Advice - Tel: 0141 945 6810
Spare Parts - Tel: 0141 945 6800
After Sales Service - Tel: 0870 333 0220

Vokèra Ireland

West Court, Callan, Co Kilkenny
Tel: 056 55057 Fax: 056 55060

Vokèra Ltd. reserve the right to change the specifications without prior notice. Consumers' statutory rights are not affected.

A Riello Group Company



"Vokèra"
supports Benchmark