

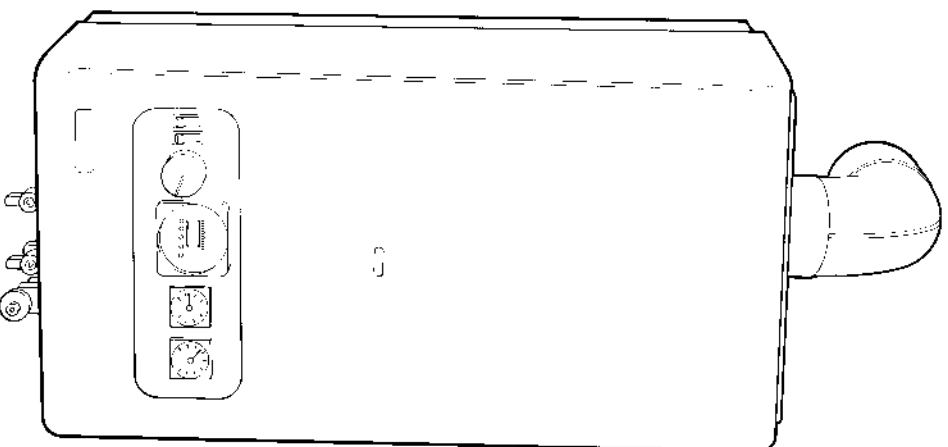

Vokera

12-48 RSSE Minute



Installation and Servicing Instructions

NATURAL GAS
SERIAL N. 773 UPWARDS

LPG GAS
SERIAL N. 13 UPWARDS

G C No. 41 094 03
British Gas Tested and Certified

**HAND THESE
INSTRUCTIONS
TO THE USER.**

This Appliance is for use
with Natural Gas only

CONTENTS

Section	Subject	Page No.	Section	Subject	Page No.
Section 1	Introduction	1			
Section 1	General Layout	1	6.11	Final check of operations	14
	Schematic Diagram	2	6.12	Concluding Operations	14
			6.13	Refining the front cover	14
Section 2	Design Principles and Operating Sequence	2	Section 7	Instructing the User	14
	2.2 Central Heating 2.2.1-2.2.2	2	Section 8	Servicing Instructions	15
	2.3 Safety Devices	2	8.1	General	15
			8.2	Important Notes	15
			8.3	Recommended Routine Servicing	15
Section 3	Technical Data	3	8.4	To Gain general access	16
	3.1 Units	3	8.5	To remove/replace room sealed chamber front cover	16
	3.2 Dimensions and Contents	3	8.6	To remove/replace Electrode & Main Burner	17
	3.3 Connection sizes	3	8.7	To remove Main Burner Injectors	17
	3.4 Installation requirements	3	8.8	To Remove Main Heat Exchanger	18
	3.5 Electrical Details	3	8.9	To Remove Flue Fan	18
	3.6 Performance	3	8.10	To Remove Flue Pressure Switch	18
	3.7 Burner Details	3	8.11	To Remove Combustion Chamber and Insulation Panels	19
Section 4	General Requirements	4	8.12	To Remove/Replace Gas Control Valve Operator and Solenoid	19
	4.1 Related Documents	4	8.13	To Remove Gas Control Valve Complete	19
	4.2 Location of Appliance	4	8.14	To Remove Pump	20
	4.3 Gas Supply	4	8.15	To Remove Heating Manifold	20
	4.4 Flue System	4	8.16	Removal of Main Expansion Vessel	20
	4.5 Air Supply	5	8.17	Removal of Safety Valve	21
	4.6 Water Circulation	5	8.18	Removal of Electrical Components	21
	4.6 Schematic Layouts	6	8.19	Removal of Mechanical Instruments and Components	22
	4.7 Electrical Supply	7			
Section 5	Installation	8	Section 9	Operation Checks, Wiring Diagrams & Fault Finding	23
	5.1 Delivery	8		Fault finding Charts	24 - 27
	5.2 Unpacking	8	Section 10	Appendix	
	5.3 Preparing for Mounting	8		Instructions for fitting Optional Time Clocks	28 - 31
	5.4 Mounting on Wall	8		Exploded Diagrams	32 - 36
	5.5 Fitting the Flue	9		Short Spare Parts List	36
	5.6 Connecting the gas and water supplies	11		Functional Flow Diagram	37
	5.7 Electrical Connections	11		General layout of wiring	38
				Illustrated Wiring Diagram	39
Section 6	Commissioning and Testing	12			
	6.1 Reference Diagram	12			
	6.2 Gas Supply Installation	12			
	6.3 Central Heating System	12			
	6.4 Electrical Supply	12			
	6.5 Lighting the boiler	12			
	6.6 Checking burner pressures	13			
	6.7 Checking the flue system	13			
	6.8 Checking the Heating Thermostat	13			
	6.9 Regulating the Heating system	13			
	6.10 Final flushing of the heating system	14			

SECTION 1 INTRODUCTION

The Vokera 12-48 FSE Mynute is a central heating boiler which by design incorporates a circulating pump, expansion vessel, safety valve, temperature gauge, pressure gauge, automatic by-pass and electronic ignition. It is produced as a room sealed category 1N appliance suitable for wall mounting applications only. It is provided with a fan powered flue outlet with an annular co-axial combustion air intake which can be rotated through 360 degrees.

The appliance is designed for use with a sealed system only and is not intended for use on an open vented system. The provision of stored domestic hot water is possible by the addition of an indirect cylinder with 'V' or 'S' plan controls.

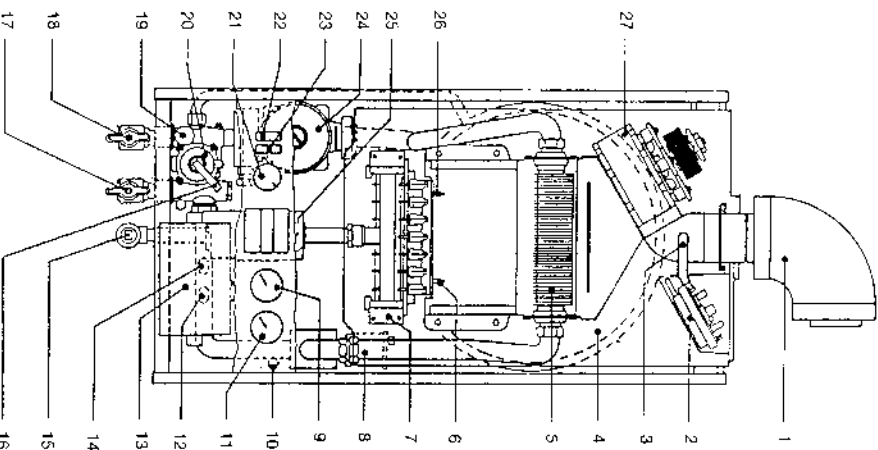
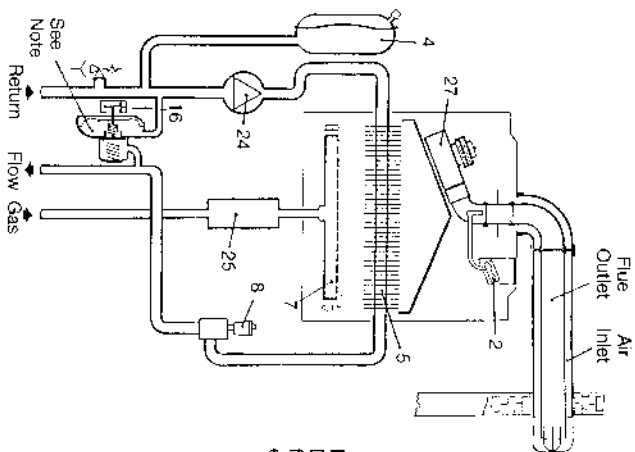

Fig 1

- 1 Air Intake
- 2 Pressure Differential Switch
- 3 Silicone Pressure Tube
- 4 Expansion Vessel
- 5 Main Heat Exchanger
- 6 Spark Electrode
- 7 Main Burner
- 8 Automatic Air Release Valve
- 9 Temperature Gauge
- 10 High Limit Stat
- 11 Pressure Gauge
- 12 Safety Thermostat
- 13 Electronic Ignition Control Box
- 14 Fan Overrun Thermostat
- 15 Gas Cock
- 16 Boiler Flow Switch
- 17 Flow Valve
- 18 Return Valve
- 19 Safety Valve
- 20 Central Heating Manifold
- 21 Boiler Thermostat
- 22 ON/OFF Switch
- 23 Mode Selector Switch
- 24 Pump
- 25 Gas Valve
- 26 Sensing Electrode
- 27 Fan

SECTION 3 TECHNICAL DATA

Fig. 2



Note
Differential pressure unit. Senses water flow rate to pump & main heat exchanger and operated flow switch (116)

SECTION 2 DESIGN PRINCIPLES AND OPERATING SEQUENCE

- 2.1** Fig 1 illustrates the general layout of components. Fig 2 illustrates the operating principles described below.
- 2.2 CENTRAL HEATING**
When the various switches and controls impose a demand for heat, the fan and pump are started. The flow of water from the pump operates a flow switch. This in turn energises both the gas valve and the electronic ignition circuitry allowing an ignition attempt. The burner ignition is checked by the electronic circuitry and once successful will allow the full rate of gas to flow through the gas valve.
- 2.2.2** As water temperature increases, this is sensed by the thermostat (21) which eventually operates to switch the burner off.
- 2.3 SAFETY DEVICES**
- 2.3.1** (A) Differential pressure unit in the circuit which prevents burner operation if the water flow rate is too low.
(B) A high limit thermostat, which interrupts the control circuit shutting off the gas valve.
(C) At the same time the fan will still run.
- 2.3.2** A safety valve is provided to relieve excess pressure.

3.1 UNITS

Dimensions and values are given in the preferred SI Units with Imperial equivalents in brackets where applicable.

3.2 DIMENSIONS AND CONTENTS

Height: 880mm (34.5in) overall
(690 casing)
Width: 360mm (14.2in)
Depth: 345mm (13.6in)
Weight empty 32.5kg (72 lbs)
Water content 0.8 litres (0.2 gals).

3.3 CONNECTION SIZES

Heating flow and return: Nut & olive for 22mm o.d.
Gas Service Rc 1/2 (1/2in BSP Int)
Safety valve outlet: Rc 1/2 (1/2 BSP Int)
Flue outlet: nom. dia. 100mm specially supplied with boiler.

3.5 ELECTRICAL DETAILS

Mains supply 240/250V ~ 50Hz Fused 3A
Power consumption: 190W

PERFORMANCE

Central Heating
Nominal Heat Input
Max: 17.6kW (60,000Btu/h)
Min 9.2kW (31,400Btu/h)
Designed temperature rise 20°C

Nominal Heat Output

Max. 14kW (48,000 Btu/h)
Min. 6.7kW (22,860 Btu/h)
Max flow temperature 85°C

Min Pressure 3.0 mbar (1.2in wg)
Working Pressure Heating System
Maximum 1.5 bar/15m.wg/50ft w.g.

Minimum 0.5 bar/5m.wg/16ft w.g.
Safety valve setting 3 bar/30m/102ft.

Flow Rates

Minimum central heating flow rate through appliance 350 litres/hour (1.28 gals/min)

Max Gas Rate 1.68m³/h 59.4ft³/h
Min. Gas Rate 0.92m³/h 32.5ft³/h

BURNER DETAILS

Main Burner: Polidoro type NP7
Main Burner Injectors 7 x 1.35

3.4.1 CLEARANCES

Minimum-above 50mm (2in) (above flue)
Minimum-below 200mm (8in) (from casing)
Minimum-in front 600mm (24in) (from casing)
Minimum-at sides 25mm (1in) (from casing)
NOTE: Vertical flue
Minimum-above 230mm (9in) (from casing).

3.4.2

Maximum heating system contents approx. 63 litres (14 gals)
Acceptance capacity of expansion vessel 6 litres (1.3 gals).

3.4.3

Air supply/ventilation: To requirements of BS 5440 Part 2 1989.

3.4.4

Means of filling sealed system: To accord with BS and/or local Water Authority requirements.

3.4.5

The standard flue duct assembly allows a maximum length of duct as follows:
Rear flue: 700mm (wall thickness)
Side flue: 890mm (to centre line of boiler).

3.7

BURNER DETAILS
Main Burner: Polidoro type NP7
Main Burner Injectors 7 x 1.35

Fig. 3

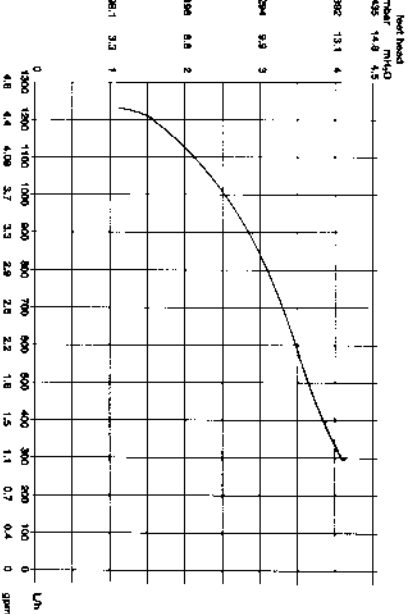

Fig. 3 shows the residual pump head available for the central heating system after allowing for the pressure loss through the appliance.

SECTION 4 GENERAL REQUIREMENTS

4.0 GENERAL REQUIREMENTS

This appliance must be installed by a competent person in accordance with the gas safety (Installation & Use) Regulations 1984.

4.1 RELATED DOCUMENTS

The installation of this boiler must be in accordance with the relevant requirements of the Gas Safety (Installation and Use) Regulations, the Local Building Regulations, the current I.E.E. Wiring Regulations, the by-laws of the local water undertaking, and in Scotland, in accordance with the Building Standards (Scotland) Regulation.

It should be in accordance also with any relevant requirements of the local gas region and local authority and the relevant recommendations of the following British Standard Codes of Practice:

BS 6891	1988	Low pressure installation pipes
BS 6798	1987	Boilers of rated input not exceeding 60kW
BS 5449	Part 1 1990	Forced circulation hot water systems
BS 5440	Part 1 1990	Flues
BS 5440	Part 2 1989	Ventilation

4.2 LOCATION OF APPLIANCE

The boiler may be installed in any room or internal space, although particular attention is drawn to the requirements of the current I.E.E. Wiring Regulations, and in Scotland, the electrical provisions of the Building Regulations applicable in Scotland, with respect to the installation of the boiler in a room or internal space containing a bath or shower.

Where a room-sealed appliance is installed in a room containing a bath or shower, any electrical switch or appliance control, utilising mains electricity should be located in such a position that it cannot be touched by a person using the bath or shower.

The location chosen for the boiler must permit the provision of a satisfactory flue and termination. The location must also permit an adequate air supply for combustion purposes and an adequate space for servicing and air circulation around the boiler. Where the installation of the boiler will be in an unusual location special procedures may be necessary and BS 6798:1987 gives detailed guidance on this aspect.

A compartment used to enclose the boiler must be designed and constructed specifically for this purpose. An existing cupboard or compartment may be used provided that it is modified for this purpose.

4.3 GAS SUPPLY

A gas meter is connected to the service pipe by the local gas region or a local gas region contractor. An existing meter should be checked, preferably by the gas region to ensure that the meter is adequate to deal with the rate of gas supply required for all appliances it serves. Installation pipes should be fitted in accordance with BS 6891.

Pipework from the meter to the boiler must be of adequate size. Pipes of a smaller size than the boiler inlet connection should not be used.

4.4 FLUE SYSTEM

The complete installation must be tested for soundness as described in the above code. N.B. If the gas supply for the boiler serves other appliances ensure that an adequate supply is available both to the boiler and the other appliance when they are in use at the same time.

The terminal should be located where dispersal of combustion products is not impeded and with due regard for the damage or discoloration that might occur to building products in the vicinity (see fig 4).

In cold and/or humid weather water vapour may condense on leaving the flue terminal. The effect of such 'steaming' must be considered.

The terminal must not be closer than 50mm (2in) to any combustible material. For protection of combustibles, refer to BS 5440:1 where the terminal is less than 2m (6.6ft) above a pavement or platform to which people have access (including any balcony or flat roof) the terminal must be protected by a guard of durable material.

A suitable guard is manufactured by G.R. Claudio (Wokerel) Ltd, Part No 018, (GC No 301 106). This guard must be fitted centrally over the terminal.

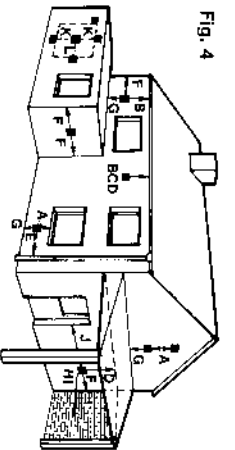

Fig. 4

N.B.

- Both vents must either communicate with the same room or space or be on the same outside wall.
- Where vents communicate with an adjacent internal space, it is suggested that the space is adequately ventilated.

TERMINAL POSITION FOR FAN ASSISTED BOILER

(minimum distance)	mm
A — Directly below an open window or other opening (e.g. air brick)	300
B — Below gutters, soil pipes or drain pipes	75
C — Below eaves	200
D — Below balconies or car port roof	200
E — From internal or external corners	75
F — From vertical drain pipes and soil pipes	300
G — Above ground or below balcony level	300
H — From a surface facing a terminal	600
I — From a terminal facing a terminal	1200
J — From an opening in the car port (e.g. door window) into dwelling	1200
K — Vertically from a terminal on the same wall	1500
L — Horizontally from a terminal on the same wall	300

4.5 AIR SUPPLY

Recommendations for air supply are detailed in BS5440:2:1989. The following notes are intended for general guidance.

The room-sealed fan flued boiler does not require a permanent air vent for combustion air supply.

Where installed in a cupboard or compartment ventilation is required for cooling.

The table below gives the recommended minimum effective areas of such air vents

POSITION OF AIR VENTS	AIR VENT AREAS	
	AIR FROM ROOM OR INTERNAL OUTSIDE	AIR DIRECT FROM OUTSIDE
high level	159cm ² (24.5in ²)	80cm ² (12.3in ²)
low level	159cm ² (24.5in ²)	80cm ² (12.3in ²)

4.6 WATER CIRCULATION

Detailed recommendations are given in BS 6798:1987 and BS 5449:1:1990 (for small-bore and micro-bore central heating systems). The following notes are given for general guidance.

4.6.2 PIPEWORK

Copper tubing to BS 2871:1:1971 is recommended for water pipe. Joining should be either by capillary soldered or with compression fittings.

Where possible, pipes should have a gradient to ensure air is carried naturally to air release points and water flows naturally to drain taps. It should be ensured as far as possible that the appliance heat exchanger is not a natural collecting point for air.

Except where providing useful heat, pipes should be insulated to prevent heat loss and to avoid freezing. Particular attention should be paid to pipes passing through ventilated spaces in roofs and under floors.

4.6.3 BY-PASS

An automatic by-pass is incorporated in the boiler and systems should be designed to ensure that with only one radiator turned on a flow rate of at least 350 litres/hour (1.28 gals/min) is achieved through the boiler.

4.6.4 SYSTEM DESIGN

Figs 5.65 illustrate typical heating only layouts, but the boiler is also suitable for installation with a 'Y' or 'S' plan system. Section 10 appendix D gives wiring details.

4.6.5 DRAINING TAPS

These must be located in accessible positions to permit the draining of the whole systems. The taps must be at least 15mm nominal size and manufactured in accordance with BS 2879:1980.

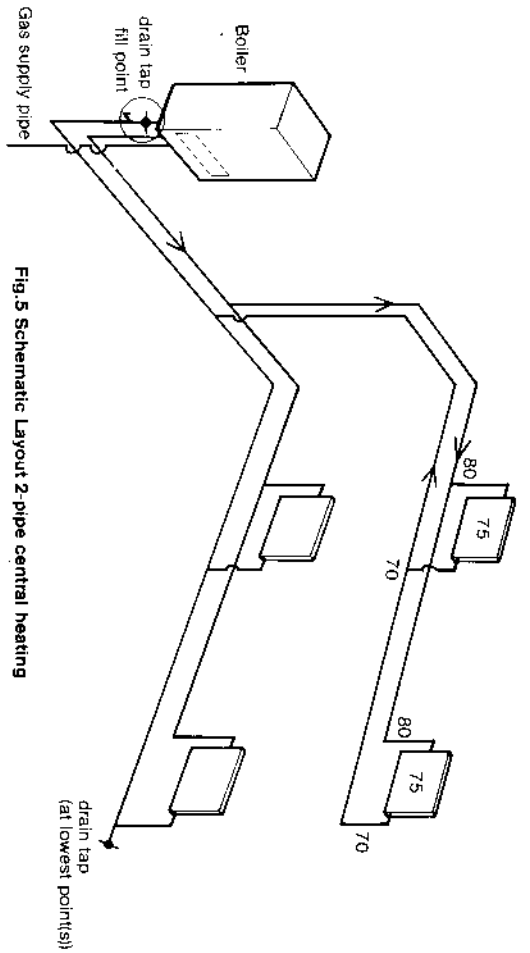

Fig. 5 Schematic Layout 2-pipe central heating

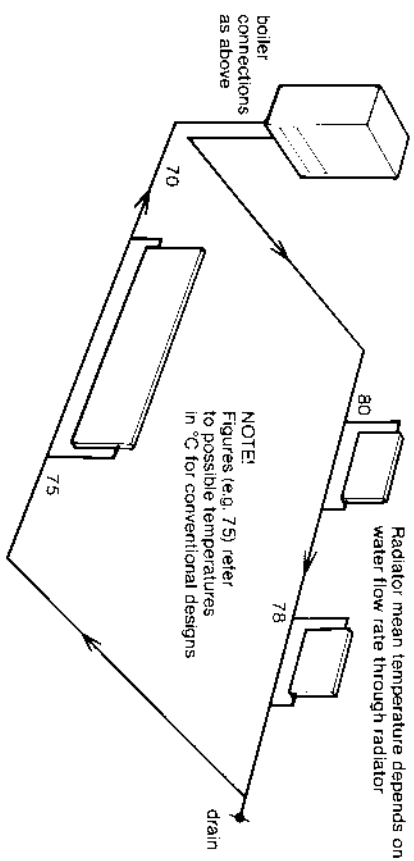

Fig. 6 Schematic single pipe central heating

SALIENT FEATURES OF EACH SYSTEM

2 PIPE

- Radiators connected in parallel
- Water flow to each directly affected by pump
- Shutting off radiators affects total flow in system
- Radiators have approx. same mean temperature
- Low flow rate affects all radiators equally

1 PIPE

- Each radiator is on individual circuit off main pipe
- Water flow not directly affected by pump. Flow in each radiator depends on thermostat + pressure differential between connection to main circuit.
- Shutting off individual radiators hardly affect total flow in system.
- Radiator mean temperature progressively drops around systems.
- Low flow rate seriously affects last radiators on circuit.

N.B. Vokera Ltd recommend a 2-pipe system. Single pipe systems are more liable to be troublesome unless carefully designed and installed.

4.6.6 AIR RELEASE POINTS

These must be fitted at all high points where air will naturally collect, and must be sited to facilitate complete filling of the system.

4.6.7

The appliance has an integral sealed expansion vessel to accommodate the increase of water volume when the system is heated. It can accept up to 6 litres (1.3gal) of expansion water. If the appliance is connected to a system with an unusually high water content, calculate the total expansion and add additional sealed expansion capacity as appropriate. In general, modern systems will present no problem.

4.6.8

FILLING POINT

A method for initially filling the system and replacing water lost during servicing must be provided, and it must comply with local water authority regulations. A method is shown in Fig 7 using the Vokera filling loop which is acceptable in most areas. In the event that this method is not suitable in a particular area, contact the local authority for preferred methods.

N.B. The installer should ensure that no leaks exist as frequent filling of the system could cause premature scaling of the main heat exchanger

4.7

ELECTRICAL SUPPLY

The appliance is supplied for operation on 240/250V ~ 50Hz electricity supply. It should be protected with a 3-amp fuse. **THIS APPLIANCE MUST BE EARTHED.**

The method of connection to the mains electricity must allow complete isolation from the supply.

The preferred method is by using a fused double pole switch with a contact separation of at least 3mm.

The switch must supply **ONLY the appliance** and immediate electrical control circuits (e.g. programmer/room thermostat) Alternatively, use an unswitched shunted socket outlet with a fused 3-pin plug both complying with BS 1363.

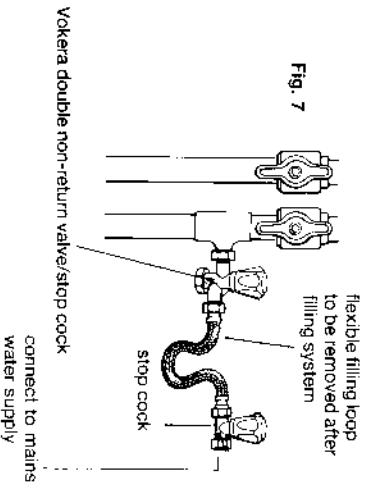

Fig. 7

5.1 DELIVERY

The appliance is delivered in a heavy duty cardboard carton. A template is printed on one side of the carton. This should be carefully cut out and used prior to installation to mark the locations for fixing holes for the upper bracket and the flue.

- Packed with the boiler are:
- 1 – Wall Bracket
 - 1 – Fittings pack containing central heating valves (2)
 - Gas service tap (1)
 - Fibre washers (2)
 - 1 – Installation Manual.
 - 1 – Users Instructions

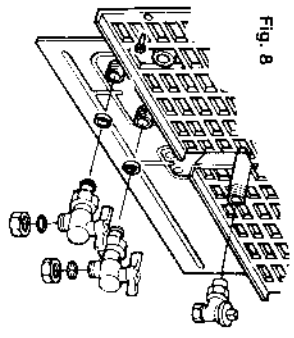

Fig. 8

5.2 UNPACKING

5.2.1 Open the top of the carton and remove accessories and top packing.

5.2.2 Lay the carton with the words 'truck here' on the floor, restrain the carton, grip the black frame (not the flue or casing) and withdraw the appliance.

5.3 PREPARING FOR MOUNTING

5.3.1 Remove 4 screws securing the lower part of the casing to the base frame.

5.3.2 Slightly lift the casing, flex outwards at base, and slide it gently towards the top of the appliance to disengage the case from the top suspension hooks.

5.3.3 Ensure the casing and screws are put to one side in a safe place.

5.3.4 Loosely fit (hand tight) the valves and fittings using the washers supplied (fig 8)

5.4 MOUNTING THE APPLIANCE

Refer to fig 9

5.4.1 Place the template on a smooth, vertical, non-combustible surface and use it to locate the bracket base and the flue pipe hole. Alternatively, position bracket and hole to dimensions in fig 9.

5.4.2 Drill and plug the wall for 2-2" No 10 screws for upper bracket and screw the bracket firmly into position using rust proof countersunk screws.

5.4.3 Hang the boiler on the bracket and adjust to final position.

5.4.4 Drill a 105mm hole through the wall to allow passage of the flue pipe

Refer to fig. 9 and figs. 10-13 for relevant dimensions for locating the hole. Where it is remote from the boiler take special care to ensure hole is at the correct level so that the finished flue is horizontal.

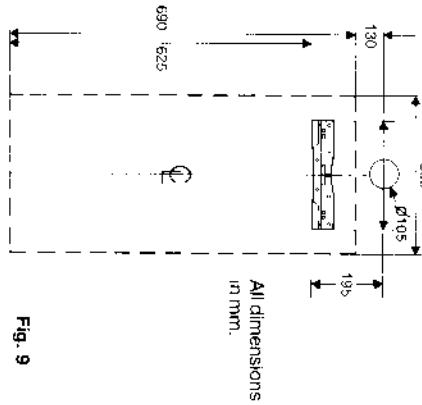

Fig. 9

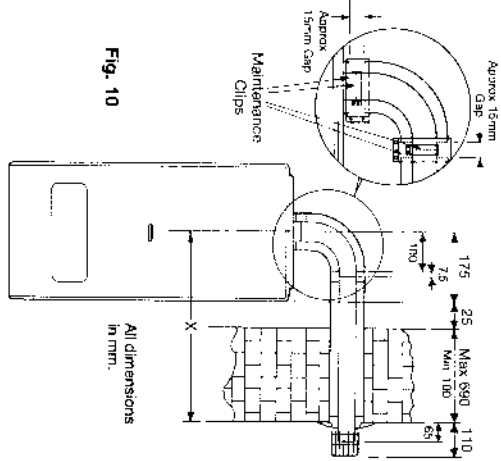

Fig. 10

5.5 FITTING THE FLUE

5.5.1 Refer to figures 10 - 13.

5.5.2 The flue outlet elbow may be rotated 360 degrees on its vertical axis. The flue may be extended from this in the horizontal plane. The standard flue pipe supplied may be used for lengths up to 890mm - from the outside of wall to centre of the flue elbow. Extension kits (Part No. 026 G.C. No. 370 346) are available to order for flue extensions of up to 4.5 metres total length of straight flue.

5.5.3 Hang the boiler on the bracket. Adjust the boiler sideways to its correct position. Locate the small maintenance clip on to the flue elbow (fig 10) and assemble onto the flue outlet on the top of the boiler. Twist the flue bend to the outlet direction required, and tighten the maintenance clip to secure the flue bend in place. Carefully level across to check that the hole through the wall is at the same level as the flue bend.

5.5.4 Measure carefully from the actual face of the outside wall to the centre of the flue bend. (Dimension X on Figs 10 & 11).

5.5.5 The flue kit supplied is suitable for an exact dimension of 890mm.

5.5.6 Where X is less than 890mm, the supplied flue must be shortened as follows:-
Subtract the measured length from 890mm. The difference is the precise length to be removed from the inner flue tube (890 - X = length to be cut off).

NOTE: The two tubes must be separated by removing screw G (fig 12) before cutting. The outer air tube should also be shortened by the same amount to allow a gap for easy working (see inset on fig 10).

EXAMPLE

X is measured as 630mm. Amount to be cut off inner tube is 890 - 630 = 260.

5.5.7 Where X is more than 890mm an extension kit (or kits) is needed. The standard uncut lengths with extension(s) is as follows:-

- 1 extension = 1740mm
 - 2 extensions = 2590mm
 - 3 extensions = 3440mm
 - 4 extensions = 4290mm
- Cut 5th extension for a Maximum length of 4.5 metres.

The same procedure is followed:

- 1. Measure X
- 2. Subtract X from appropriate figure and shorten the tubes accordingly.

EXAMPLES

X = 1295

1740 - 1295 = 445
Shorten inner and outer tubes of last extension by 445mm

X = 1920 so 2590 - 1920 = 670

Shorten inner and outer tubes of last extension 670mm
CUT CLEAN AND SQUARE WITH FINE TOOTH SAW AND REMOVE BURRS.

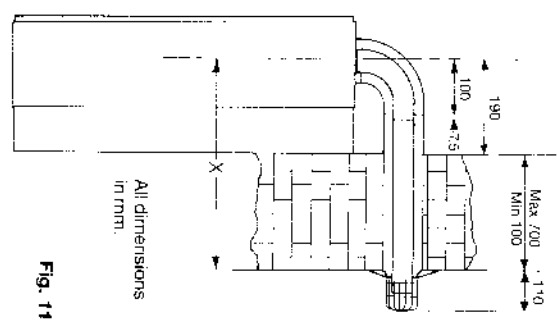

Fig. 11

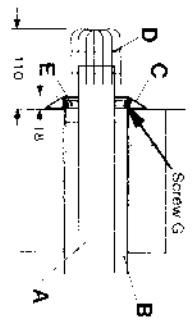

Fig. 12

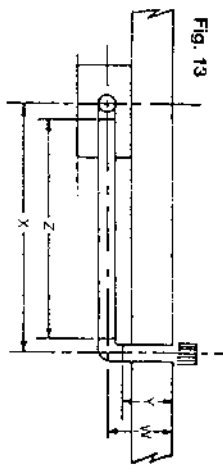

Fig. 13

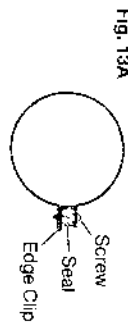
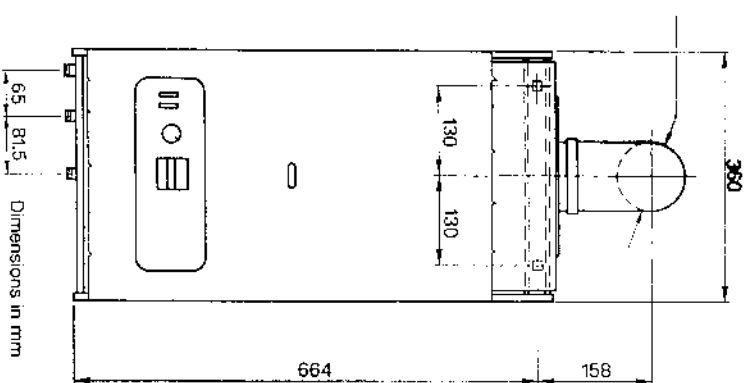

Fig. 13A

- 5.5.8** Loosen the small maintenance clip and lift off the flue bend
- 5.5.9** Ensure inner and outer terminal tubes are firmly fitted together with screw G (fig 12). Push the terminal tubes through the wall until the face of the outer tube protrudes 18mm from the face of the wall (fig 12). The terminal grill (D) will then protrude 110mm from the wall face.
- 5.5.10** If extension pieces are used assemble these using the maintenance clips provided.
- 5.5.11** Make sure the entire length of the flue is truly horizontal and adequately supported. Use at least one bracket for each extension. (Conventional adjustable strap supports suffice. Vokera stockist can supply if necessary. Part No 03 (GC No 301 105))
- 5.5.12** Assemble the second small maintenance clip on the end of the inner flue tube.
- 5.5.13** Refit the flue elbow onto the boiler. Align the flue elbow with the flue pipe and tighten the maintenance clip between the flue elbow and the boiler.
- 5.5.14** Draw the flue pipe towards the boiler and tighten the second clip over the joint between the inner flue pipe and the flue elbow.
- 5.5.15** There must now be a gap of approximately 15mm from the elbow to the end of the outer tube.
- 5.5.16** Check also that the outer end of the flue projects as indicated in fig 12.
- 5.5.17** Referring to fig 10 fit the large maintenance clips into position and secure the clip screws.
- 5.5.18** Check adjust and tighten all supports.
- 5.5.19** Seal the peripheral gap around the outer tube with cement or mastic and slip the cosmetic flexible plastic collar (fig 12) item C) into groove on the pipe. This operation can only be carried out with external access.
- N.B. Absence of the collar will not affect operation of the appliance.
- 5.5.20** **INSTALLING ONE OR TWO ADDITIONAL 90° FLUE BENDS**
Part No 02 (GC No 301 104)
- 5.5.21** Assemble the large and small maintenance clips as shown in fig 13A
- 5.5.22** Carry out steps 5.5.2-5.5.3
- 5.5.23** Ensure when siting the flue hole position that the total length of the straight flue pipe used does not exceed the maximum permissible. 1 extra 90° bend and a maximum of 3.75 metres of straight flue. 2 extra 90° bends and a maximum of 3.0 metres of straight flue.
- 5.5.24** Measure carefully the distance between the centre of the flue bend on the boiler to the centre of the hole through the wall (dimension X fig 13).
NOTE: Extension kit's (Part No 026) will be required when using additional 90° bends.
- 5.5.25** Subtract 230mm from the measured dimension, separate the two tubes and cut the outer tube to this dimension.
- 5.5.26** Cut the inner tube 15mm longer than the outer tube.
- 5.5.27** Referring to fig 10 assemble a small maintenance clip on the outlet of the boiler flue bend. Push the inner flue tube into clip and tighten clip screws.
- 5.5.28** Slide the outer flue tube into place leaving approx. 15mm between the bend and the flue tube.
- 5.5.29** Referring to fig 10 fit the large maintenance clip into position and tighten clip screws.
- 5.5.30** Connect the flue tube to the extra bend using the same method ensuring that the bend outlet is in line with the hole through the wall.
- 5.5.31** Ensure that the flue pipe runs parallel to the wall then carefully measure the distance from the outside face of the wall to the centre of the extra bend (dimension W fig 13).
- 5.5.32** Subtract 97mm from the dimension and cut the outer tube to this length.
NOTE: The two tubes must be separated by removing screw G fig 12 before cutting.
- 5.5.33** Ensure that any shortening of the tube is done from the plain end.
- 5.5.34** Reassemble the inner and outer flue tubes and refix screw G.
- 5.5.35** Mark the inner tube 7mm longer than the outer and cut off the inner tube at this point.
- 5.5.36** Remove the large maintenance clip, loosen the small clip and remove the bend.
- 5.5.37** Push the flue tubes through the wall, loosely refit the extra flue bend.
- 5.5.38** Assemble a small maintenance clip onto the inner flue tube, draw the flue tube towards the flue bend until the inner tube butts. Tighten the screws on the small clip.
- 5.5.39** Referring to fig 10 fit the large maintenance clip into position and secure clip screws.
- 5.5.40** Check and adjust if necessary so that the outer flue tube protrudes 18mm from the outside face of the wall.
- 5.5.41** Tighten all maintenance clips, make sure that the entire flue is horizontal and adequately supported. Use at least one bracket (Part No 03, G.C. No 301 105) for each extension.

- 5.6** **CONNECTING THE GAS AND WATER**
- 5.6.1** Figs 8 and 14 show the locations of the fittings.
- 5.6.2** Do not over tighten nuts and use another spanner to apply counterforce to avoid damaging the appliance.
- 5.6.3** **GAS SUPPLY**
Connecting the gas supply.
Connect a 15mm gas pipe to the gas service tap and tighten the union nut securing the tap to the appliance.
- 5.6.4** **CENTRAL HEATING**
Connect the central heating pipework (22mm o.d.) to the respective valves, right hand - flow, left hand = return, and tighten the nuts.
- 5.6.5** **SAFETY VALVE DISCHARGE**
The safety valve is located beneath the pump. It has a threaded outlet (Fic 1/2" BSP In) to permit a discharge pipe to be connected. When connecting, ensure the discharge pipe does not restrict access to or operation of the central heating valves. The discharge siphon terminate facing downwards exterior to the building in a position where discharging (possible boiling) water will not create danger or nuisance, but in an easily visible position.
- 5.7** **ELECTRICAL CONNECTIONS**
- 5.7.1** The electricity supply must be as specified in clause 4.7. If controls external to the appliance are required design of the electrical circuits should be undertaken by a competent person.
See section 10 for further electrical wiring details.
Factory fitted internal wiring must not be disturbed when wiring external controls
N.B. IT IS ESSENTIAL THAT ALL EXTERNAL CONTROL CIRCUITS AND WIRING IS WIRED FROM THE SAME ELECTRICAL ISOLATOR AS SERVES THE APPLIANCE.
To gain access to the terminals release the 2 screws securing the outer control fascia (top corners)
Note these 2 screws and associated cup washers are not captive. Ensure they are not lost.
The panel is bottom hinged. Pull it forwards and downwards until it rests in an approximately horizontal position.
The terminal block is easily visible on the left hand side.
- 5.7.2**
- 5.7.3** The electricity supply cable from the isolator and the Appliance terminal block must be 3 core flexible sized 0.75mm² (24X0.2mm) to table 15-16 BS 6500.
- 5.7.4** Wiring to the Appliance should be rated for operation in contact with surfaces up to 90°C. Pass the cable through the cord anchorage and connect it so that should the cable slip the anchorage the current carrying conductors become taut before the earthing conductor.
- 5.7.5** Securely tighten all terminal screws and arrange the cable with slack between the anchor and the terminal block. Tighten the cord anchorage.
- 5.7.6** Nearly arrange the external cable in such a way that unrestricted opening of the controls fascia is possible without strain on the cable.
- 5.7.7** External controls may be wired from terminals 2 and 3 (after removing the factory fitted link). If a neutral is needed use terminal N.
If required pass this cable through the same cord anchorage.
The conductor should be so connected that the conductor to terminal 2 becomes taut before those to 3 or Earth (#) should the cable be strained.

Fig. 14



- 6.1 Where the text bears identifying numbers in brackets, refer to figs. 1 and 2 unless otherwise instructed.
- 6.2 **GAS SUPPLY INSTALLATION**
Inspect the entire installation including the meter, test for soundness and purge, all as described in BS 6891.
- 6.3 **CENTRAL HEATING SYSTEM**
6.3.1 **IMFOURTANT**
Do not release air from the red sealed expansion tank. It is charged with air at the factory to 1 bar (15psig).
6.3.2 **INITIAL FLUSHING OF THE PIPEWORK**
The appliance contains components likely to be damaged or blocked by grease and dirt from the system. It is recommended therefore that the appliance be disconnected from the system for the initial flush.
6.3.2.2 Close the appliance central heating valves and disconnect from the appliance.
6.3.2.1 Connect a temporary water supply to the return and a drain pipe to the flow and flush the entire system until the drain discharges clean water (for at least five minutes).
Drain the system by opening the drain taps at all low points. Close the drain taps and reconnect the flow and return pipes to the appliance.
- 6.3.3 **INITIAL FILLING OF THE SYSTEM**
6.3.3.1 See Clause 3.4.4. and 4.6.8
6.3.3.2 Open central heating flow and return valves (red handle vertical indicates open, horizontal indicates closed). Unscrew black cap on automatic air release valve (8) one full turn (leave open permanently).
6.3.3.3 Close all air release taps on central heating system.
6.3.3.4 Gradually open stopcock at the filling point connection to the central heating system until water is heard to flow. Do not open fully.
6.3.3.5 Starting with the lowest radiator open each air release tap in turn closing it when clear water, free of bubbles, flows out. In the same way release air from any high points in the pipework.
6.3.3.6 Continue filling the system until at least 1.5bar registers on the gauge (11) then turn off the filling stopcock.
6.3.3.7 Inspect the system for water soundness and remedy any leaks discovered.
- 6.3.4 **SETTING THE SYSTEM DESIGN PRESSURE**
6.3.4.1 The design pressure must be a minimum 1.0bar and a maximum of 1.5bar.
- 6.3.4.2 The actual reading should ideally be 1.0bar plus the height in metres to the highest point of the system above the base of the appliance (up to the maximum of 1.5bar total).
6.3.4.3 To lower the system pressure to the required value turn the red knob of the safety valve (19) a quarter turn to release water until the required figure registers on the gauge (11).
6.4 **CHECKING ELECTRICITY SUPPLY**
6.4.1 Carry out preliminary checks for earth continuity, polarity, and resistance to earth. Gaining access as required according to clause 5.7.2 in this manual.
6.4.2 Leave the appliance with the control fascia closed and secured and with the mains electricity switched OFF.
- 6.5 **LIGHTING THE BOILER**
6.5.1 Ensure flow and return valves are open (C) (6.3.3.2).
If external controls are fitted (e.g. Timeclock and Room thermostat) ensure they call for heat. The commissioning of the appliance may be easier if the external controls are disconnected and terminals 2 and 3 linked. (For access procedure turn off electricity and refer to clause 5.7.2 for instructions).
6.5.2 Switch on the mains electricity and turn on the appliance switch (22).
6.5.3 Set the control thermostat at its highest setting.
6.5.4 Set the Timer/Constant switch (23) to constant.
6.5.5 The boiler will now go through an ignition sequence and the burner will light.
6.5.6 If during the ignition attempt period (10 seconds approx), the boiler fails to light, the ignition control circuit will go to lockout de-energising the gas valve, but leaving the fan and pump running.
6.5.7 In the event of the boiler going to lockout turn the appliance switch to the off position. The most common cause of the boiler going to lockout during commissioning is air in the gas supply. Check that the gas supply is completely purged of air and that gas is reaching the boiler then repeat from 6.5.2.

6.6 **CHECK BURNER PRESSURE**

- 6.6.1 The heat input is factory set to the maximum value given in section 3.6 but it is necessary to check/adjust this when commissioning. The maximum heat input may be reduced by a simple adjustment to suit the system load. Refer to fig 15 to determine the pressure for the heating output you need (e.g. for 40,000 Btu/h a pressure of 8mbar is needed).
6.6.2 Turn off the main electricity supply. Gain access to the interior as instructed in clause 5.7.2.
6.6.3 Locate the main burner pressure test point (Fig 16) and slacken the screw half a turn in an anti clockwise direction. Attach a suitable pressure gauge. Turn on the boiler for central heating.
6.6.4 The pressure reading for maximum output should be 10.5 mbar/4.26in wg (plus or minus 1.0mbar/0.42in wg). If the pressure is wrong or if it is required lower it should be adjusted by removing regulator cover screw (fig 16) and adjust regulating screw underneath. Once this pressure has been fixed it should be indelibly recorded on the data badge. This is to ensure that the burner can be reset when any service operation involves alteration of burner settings.
- 6.7 **CHECKING THE FLUE SYSTEM**
6.7.1 The flue system should be visually checked for soundness. Check all clamps and fixings are secure and tight.
- 6.8 **CHECKING THE HEATING THERMOSTAT**
6.8.1 Allow the system to warm up and manipulate the control thermostat to ensure the burner switches from 'on' to 'off' and vice versa (scale range covers approx. 45°C - 85°C).
- 6.9 **REGULATING THE CENTRAL HEATING SYSTEM**
6.9.1 Fully open all radiators and circuit valves and run the appliance in the central heating mode until heated water is circulating. If conditions are warm, remove any thermostatic valve heads.
6.9.2 If the burner will not light, ensure that water is intact circulating. See cl 4.6.3
6.9.3 Adjust radiator return valves and any branch circuit return valves until the individual return temperatures are correct and are approximately equal.
6.9.4 When all is adjusted, progressively close all radiator valves to ensure that the appliance still operates when flow through the system is limited.
If the burner cuts out prematurely due to lack of water flow through the appliance, the system should be regulated to ensure a flow rate of at least 350 litres/hour (1.28 gals/min).

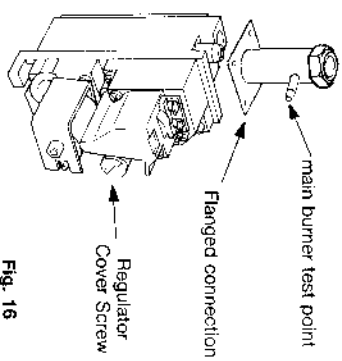
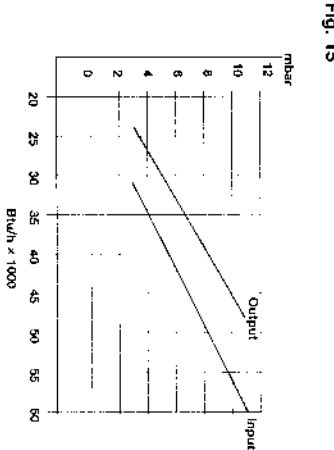

- 6:10 **FINAL FLUSHING OF THE HEATING SYSTEM**
After the system has been thoroughly heated to about 60°C (140°F) or above, and hot water has circulated to all parts any residual grease, flux and other foreign material will have been dislodged.
- 6:10.2 Inspect the system for soundness. Turn the appliance off and turn off the on/off switch (fig 1 22).
Open all drain taps and quickly drain the system whilst still hot to remove offending substances. Refill as instructed in clause 6.3.3.
- 6:11 **FINAL CHECK FOR OPERATIONS**
- 6:11.1 Disconnect pressure gauge, relighten screw, Relight boiler.
- 6:11.2 Re-check for gas soundness.
- 6:11.3 Re examine heating and hot water systems and cold water supply for water soundness.

- 6:11.4 Check the appearance of the gas flame to assess adequacy of combustion air supply.
- 6:11.5 Re-check the flue system for soundness and adequacy of supports.
- 6:12 **CONCLUDING OPERATIONS**
- 6:12.1 If external controls have been disconnected and terminals 2 and 3 temporarily linked remove the link and reconnect the external control circuit, check the operation of the external controls.
- 6:12.2 Hinge up and resecure the control fascia.
- 6:13 **REFIXING THE FRONT CASING.**
- 6:13.1 Offer up the front casing to the back frame in a near vertical attitude and locate the hooks on the casing over the hooks on the frame. Slide the casing downwards to fully engage the hooks and flex the bottom of the case outwards and push home to align the bottom fixing holes. Replace the four case retaining screws.

SECTION 7 INSTRUCTING THE USER

- 7:1 Hand over the copy of the Users Instructions supplied together with this installation book and explain how to operate the boiler correctly. Explain how to use the Timeclock and Room Thermostat if fitted.
- 7:2 Show the user how to switch off the appliance quickly and indicate the position of the electric supply isolator.
- 7:3 Explain that air supply grilles must not be blocked in any way.

- 7:4 Inform the user of the location of all drain cocks and air vents.
- 7:5 Explain how to turn the appliance off for both short and long periods and advise on the precautions necessary to prevent damage should the appliance be inoperative when freezing conditions may occur.
- 7:6 Finally, advise the User that, for continued safe and effective operation, the appliance must be serviced by a competent person at least once a year.

SECTION 8 SERVICING INSTRUCTIONS

- 8:1 **GENERAL**
To ensure efficient safe operation of the appliance it is necessary to carry out routine servicing at regular intervals.
The frequency of servicing will depend upon the particular installation conditions and the use to which the boiler's put, but, in general, once per year should be adequate. It is the law that any service work must be carried out by a competent person such as British Gas or other recognised companies.
The following instructions apply to the boiler and its controls, but it should be remembered that the central heating system will also require attention from time to time.

- 8:2 **IMPORTANT NOTES**
WARNING: Having carried out preliminary flame checks and before starting any servicing work, switch OFF the mains electricity supply and disconnect the plug at the main isolating switch and socket. (If a switch is used remove the fuse.)
Turn off gas supply at the gas service tap fitted to the appliance.
Always test for gas soundness after any service work and after exchanging any gas carrying component.
- 8:3 **RECOMMENDED ROUTINE SERVICING**
8.3.1 **ANNUAL SERVICING**
The following procedures should be carried out at least once per year.
 1. Inspect exterior for signs of damage and deterioration particularly of flue pipework and electrical connections.
 2. Inspect air supply and ventilation arrangements comparing them with the requirements laid down in clauses 4.5.1 & 2 to ensure no alterations have been made since installation.
 3. Turn off mains electricity and remove front casing (see clause 8.4).
 4. Replace fuse if previously removed (8.2 above) and turn on electricity, run the boiler for a few minutes to permit inspection of its operation, inspect the burner for yellowing of flame tip, flame lift off or sootling.

- 8:3.2 **REPLACEMENT OF PARTS**
The life of individual components varies and they will need servicing as and when faults develop. The fault finding sequence charts in section 9 will serve to locate which component is the cause of any malfunction, and instructions for removal, inspection and replacement of the individual parts are given in the following pages.
 5. Ensure central heating valves (fig 1) are open. Note these are 1/4 turn valves which are open when handle is vertical, closed when handle is horizontal.
 6. Turn off mains electricity and turn off gas service tap on the appliance.
 7. Gain general access as described below in clause 8.4.
 8. Remove main burner, cf 8.6.3 to 8.6.8. Lightly clean with a soft brush and inspect for damage. If during initial inspection, any combustion irregularity was suspected, remove injectors and clean or replace (see clauses 8.6 and 8.7).
 9. Place cloth below combustion chamber to catch debris. Clean heat exchanger using suitable brushes and rods if necessary.
 10. Inspect combustion chamber lining. The insulating material is easily damaged. Do not scrape, but clean off lightly. If any panels are damaged these should be replaced (see Clause 8.11).
 11. Replace all parts in reverse order but leave the controls fascia open and outer casing off.
 12. Undertake a complete commissioning check as detailed in section 6.
 13. Close up and secure control fascia and refix front casing.
 14. Clean off casing using soft cloth and dilute detergent.

8.4 TO GAIN GENERAL ACCESS

To remove components access to the interior is essential. Refer to figs 17 & 18. Ensure electricity supply is isolated before carrying out any servicing.

8.4.1 To remove front casing

Release 4 retaining screws (fig 17).

Flex out base of casing and pull bottom of case slightly forward and push case upwards to disengage top hooks from the main frame and withdraw the case from the appliance.

8.4.2 To open control fascia release 2 screws (fig 17) at the top of the fascia and swing down (fig 18).

8.4.3 Remove 2 vertical screws and pull lower plastic grill downwards.

8.5 ROOM SEALED CHAMBER FRONT COVER (including viewing window)
Part No 5397
Refer to fig 19

8.5.1 Gain general access as 8.4

8.5.2 Remove roomsealed front cover plate by releasing six screws (fig 19) and easing cover off. The screws are not captive. Inspect gasket for damage. If damaged, replace.

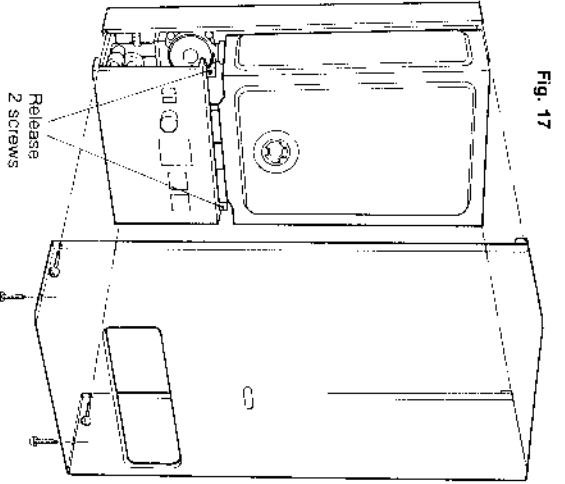

Fig. 17

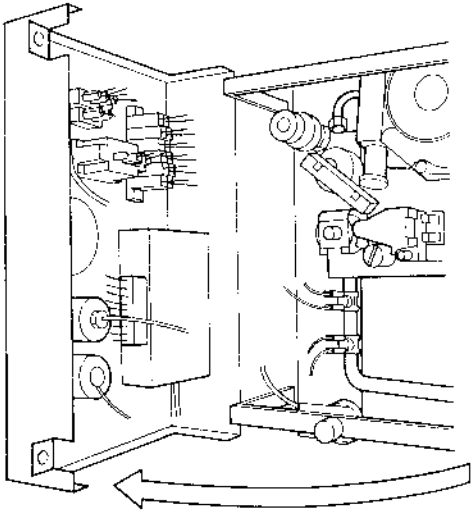

Fig. 18

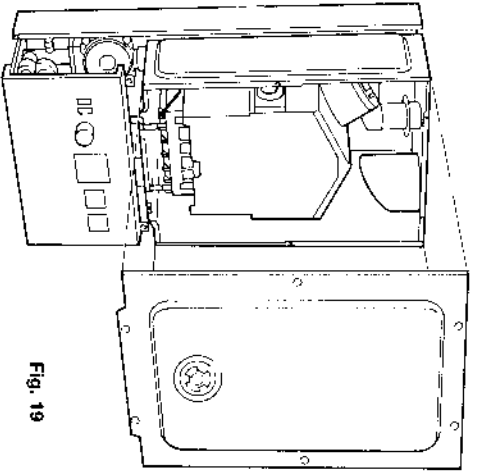

Fig. 19

8.6 MAIN BURNER AND/OR SPARK AND SENSING ELECTRODES
Part No's 5640 and 5641
Refer to figs 20, 21 & 22

8.6.1 Gain general access as 8.4

8.6.2 Remove room-sealed front cover as 8.5.2

8.6.3 Remove front of combustion chamber by releasing five screws (fig 20)

8.6.4 Remove four burner retaining screws (fig 21) ease burner forward and rest on chamber base.

8.6.5 Release electrode retaining screws and carefully remove electrodes (fig 22).

8.6.6 Trace electrode lead to electronic ignition control and disconnect.

8.6.7 Repeat for other electrode.

8.6.8 Remove main burner. Reassemble in reverse order ensuring correct location of electrodes. Ensure that left hand electrode is connected to terminal 4 of electronic ignition control box.

8.7 MAIN BURNER INJECTORS

8.7.1 Gain general access as 8.4

8.7.2 Remove room-sealed front cover as 8.5.2.

8.7.3 Remove front of combustion chamber as 8.6.3.

8.7.4 Remove main burner as 8.6.4 - 8.6.5

8.7.5 Unscrew injector(s). Reassemble in reverse order.

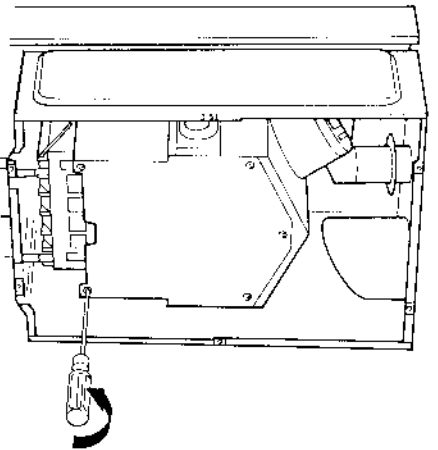

Fig. 20

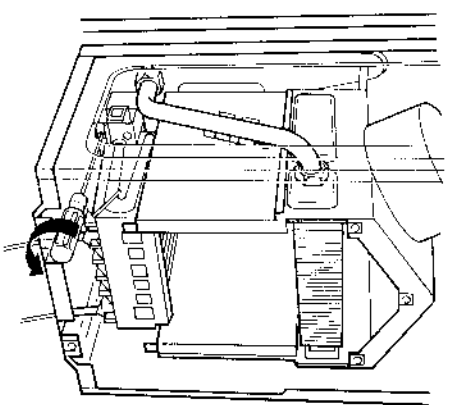

Fig. 21

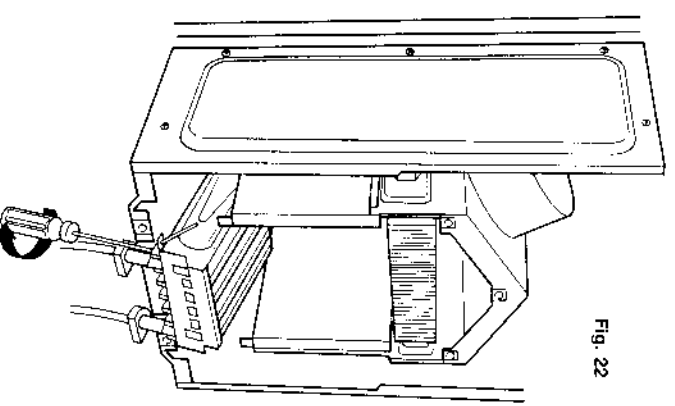

Fig. 22

8.8 MAIN HEAT EXCHANGER

Part No 5388
Refer to fig 23

- 8.8.1 Gain general access as 8.4
- 8.8.2 Remove room-sealed front cover plate as 8.5.2
- 8.8.3 Remove front of combustion chamber as 8.6.3
- 8.8.4 Close heating valves (1/4 turn until handle is horizontal). Turn safety valve 1/4 turn to drain primary circuit of boiler.
- 8.8.5 Place cloth under heat exchanger to catch surplus water.
- 8.8.6 Unscrew unions on both sides.
- 8.8.7 Carefully slide out heat exchanger avoid spillage of water on boiler electric's.
- 8.8.8 Reassemble in reverse order using new fibre washers on both unions.
- 8.9 **FLUE FAN**
Part No 5963
- 8.9.1 Gain general access as 8.4
- 8.9.2 Remove room-sealed front cover plate as 8.5.2
- 8.9.3 Remove front of combustion chamber as 8.6.3
- 8.9.4 Unscrew maintenance clip securing screws and remove clip (fig 24)
- 8.9.5 Remove silicone pipe from nozzle on inner flue bend.
- 8.9.6 Remove 3 flue hood retaining screws (fig 24)
- 8.9.7 Carefully slide flue hood forward disconnecting electrical leads on fan in the process.
- 8.9.8 Unscrew 3 screws retaining fan to flue hood and remove fan. Transfer aluminium manifold (2 screws) to new fan.
- 8.9.9 Reassemble in reverse order/replacing centre screw first.
- 8.10 **FLUE PRESSURE DIFFERENTIAL SWITCH**
Part No 5926
Refer to fig 24
- 8.10.1 Gain general access as 8.4
- 8.10.2 Remove room-sealed front cover plate as 8.5.2
- 8.10.3 Remove 3 screws holding pressure differential switch cover (fig 24) and remove cover.
- 8.10.4 Pull air tube from nozzle on inner flue bend.
- 8.10.5 Pull off tab connectors and ease pressure switch upwards, disconnecting air pressure pipe in the process.
- 8.10.6 Reassemble in reverse order. See fig 38 for correct fitting of electrical connections. The air pipe must be reconnected to the upper nozzle on the pressure switch.

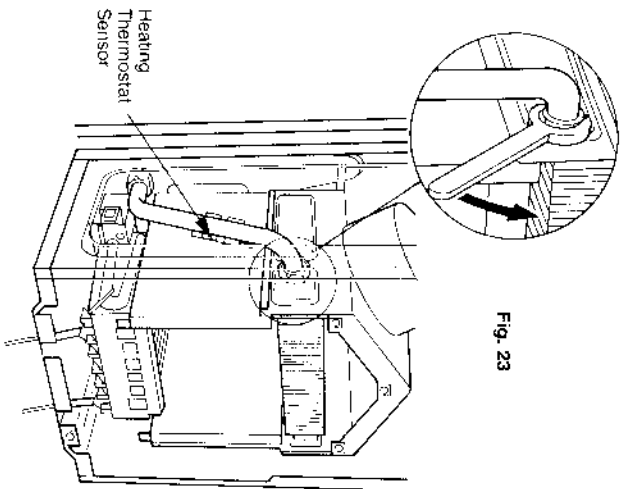

Fig. 23

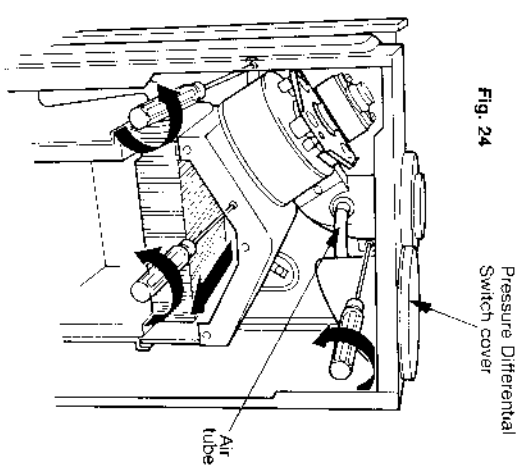

Fig. 24

8.11 COMBUSTION CHAMBER INSULATION BOARDS

- 8.11.1 Gain general access as 8.4
- 8.11.2 Remove room-sealed front cover 8.5.2
- 8.11.3 Remove front of combustion chamber 8.6.3
- 8.11.4 Remove main heat exchanger 8.8
- 8.11.5 To remove side combustion chamber insulation boards, gently prise upwards and pull out.
- 8.11.6 To remove rear board, gently prise upwards and pull out.
- 8.11.7 Fourth board (front) is replaced complete with combustion chamber front panel.
- 8.11.8 Reassemble in reverse order.
- 8.12 **GAS CONTROL VALVE, OPERATOR AND SOLENOID.**
Refer to figs 25, 26 & 27
- 8.12.1 Gain general access as 8.4
- 8.12.2 Turn off gas service tap.
- 8.12.3 **SERVO PRESSURE REGULATOR**
Refer to Fig 26
- 8.12.4 Pull off all electrical leads from operator tab connectors, also remove earthing tags.
- 8.12.5 Release 2 screws securing regulator to valve body.
- 8.12.6 Remove module and rubber diaphragm from valve body.
- 8.12.7 Carefully place new rubber diaphragm in position on valve body and fit replacement regulator, taking care not to displace the diaphragm.
- 8.12.8 Replace 2 screws and tighten.
- 8.12.9 Reassemble in reverse order. See fig 38 for electrical connections.
- 8.12.10 Check burner pressure as clause 6.6
- 8.12.11 **SOLENOID**
Refer to fig 27
- 8.12.12 Pull off electrical leads from solenoid.
- 8.12.13 Remove the spring blade retaining clip.
- 8.12.14 Pull off the 'C' bracket and coil assembly. See fig 27.
- 8.12.15 Place new coil in 'C' bracket and slide the assembly back onto the solenoid post.
- 8.12.16 Push the retaining clip back into position and check that bottom of clip has engaged in groove at base of solenoid post.
- 8.12.17 See fig 38 for electrical connections.

8.13 GAS CONTROL VALVE COMPLETE

- 8.13.1 Gain access 8.4.
- 8.13.2 Turn off gas supply.
- 8.13.3 Disconnect 2 earth leads.
- 8.13.4 Pull off all electrical connections.
- 8.13.5 Remove servo pressure regulator. Clause 8.12.5.
- 8.13.6 The operator can be transferred to any new valve to retain regulation settings.
- 8.13.7 Remove 4 flange securing screws at lower end. Undo union at top of supply to burner.
- 8.13.8 Remove 2 screws securing gas valve bracket to base frame and withdraw valve.
- 8.13.9 Replace in reverse order using new gaskets.
- 8.13.10 Test all joints for gas soundness.
- 8.13.11 Check burner pressure (cl 6.6)

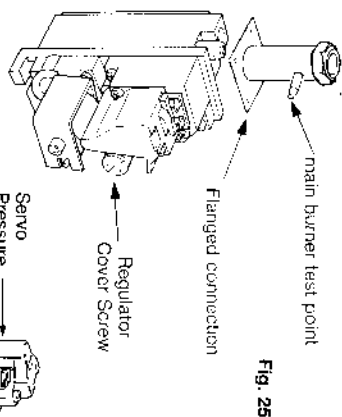

Fig. 25

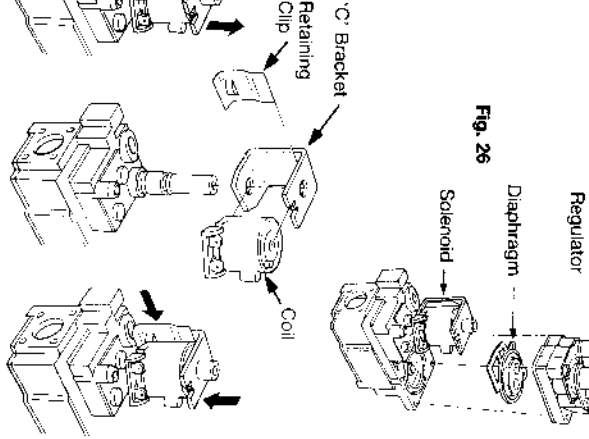
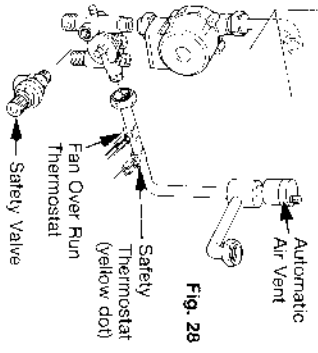

Fig. 26

Fig. 27

- 8.14 PUMP**
Part No 6090
Refer fig 28
- 8.14.1** Gain general access as 8.4
- 8.14.2** Close heating valves (fig 1, 17 & 18) by turning 1/4 turn until handles are horizontal.
- 8.14.3** Drain appliance via safety valve by 1/4 turn of safety valve knob.



- 8.14.4 (A) COMPLETE PUMP**
Disconnect pipe union connection at rear left corner of combustion chamber. Pull pipe upwards with a slight twisting movement to remove from pump union. (Access to connection is around right hand side of gas valve using that jaw adjustable spanner - 30mm across flats).
- 8.14.5** Grasp pump and pull upwards with a slight twisting movement to disconnect at inlet.
- 8.14.6 (B) PUMP HEAD ONLY**
Unscrew four Allen screws, withdraw head, disconnect electrical leads.
- 8.14.7** Reassemble in reverse order. Reconnect electrical leads. Brown to L, Blue to N, Yellow/green to E.

- MANIFOLD ASSEMBLY**
Release cover retaining screws and ease off with a screwdriver.
Refer to fig 29 for location of components.
Replace in reverse order, ensuring that washers are replaced in all union connections.
- 8.16 CHECKING/REPLACING MAIN EXPANSION VESSEL**
The expansion vessel is factory pressurised to 1 bar (14.7psi) and should be checked during servicing. Should it have lost pressure it can be repressurised in situ. Drain the boiler. Fit a suitable pump and gauge (ie car foot pump and gauge) to the nipple at the top right hand side of the expansion vessel, and pressurise to 1bar(14.7psi) and remove the pump.
- NOTE:**
Access to the nipple can be improved by loosening the upper vessel retaining screw and rocking the vessel forwards.
If the vessel cannot be repressurised or if pressure loss is very frequent the expansion vessel will require changing. Alternatively, a new vessel can be fitted in the return to the appliance, and the old vessel isolated in situ.
N.B. If the boiler is installed with a clearance above of 342mm (13.5in) or more and with a side exit flue it is possible to remove the expansion vessel in situ follow steps 8.16.10 - 8.16.11
If the clearance above is less than 342 mm (13.5in) or with a back exit flue it is not possible to remove the expansion vessel in situ, follow steps 8.16.2 - 8.16.11

- 8.15 HEATING MANIFOLD**
Part No 3175
Refer to fig 29
- 8.15.1** Remove pump as 8.14.
- 8.15.2** Disconnect safety valve discharge pipe and heating valve unions.
- 8.15.3** Remove retaining screw (securing manifold to frame).
- 8.15.4** Disconnect expansion vessel pipe union, pressure gauge connection and heating flow pipe union.
- 8.15.5** Unscrew and remove retaining nut and remove micro switch.
- 8.15.6** Remove manifold

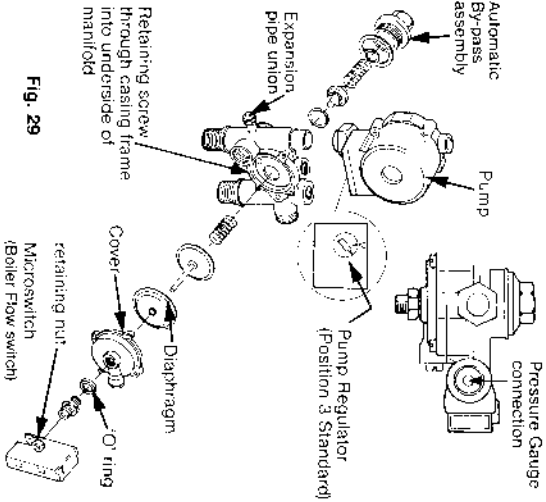

- 8.16.2** Gain access as 8.4
- 8.16.3** Close central heating valves (valve head is horizontal when closed).
- 8.16.4** Drain appliance via safety valve by 1/4 turn of knob.
- 8.16.5** Remove screws on large maintenance clips (fig 31) and remove clips. Loosen screws on the small clips and remove flue elbow.
- 8.16.6** Disconnect all pipe unions at the appliance base.
- 8.16.7** Switch OFF mains electricity and gain general access 8.4.
- 8.16.8** Disconnect electricity supply at p.c.b. (read cl. 5.7.7)
- 8.16.9** Remove clip securing vessel at top. Disconnect expansion pipe at heating manifold, lift vessel & pipe out of appliance.(fig 30)
- 8.16.10** Reassemble and remount all in reverse order.

- 8.16.2** Gain access as 8.4
- 8.16.3** Close central heating valves (valve head is horizontal when closed).
- 8.16.4** Drain appliance via safety valve by 1/4 turn of knob.
- 8.16.5** Remove screws on large maintenance clips (fig 31) and remove clips. Loosen screws on the small clips and remove flue elbow.
- 8.16.6** Disconnect all pipe unions at the appliance base.
- 8.16.7** Switch OFF mains electricity and gain general access 8.4.
- 8.16.8** Disconnect electricity supply at p.c.b. (read cl. 5.7.7)
- 8.16.9** Remove clip securing vessel at top. Disconnect expansion pipe at heating manifold, lift vessel & pipe out of appliance.(fig 30)
- 8.16.10** Reassemble and remount all in reverse order.

- 8.17 SAFETY VALVE**
8.17.1 Gain General Access 8.4.
8.17.2 Drain down primary side of boiler by closing heating valves (1/4 turn until handle is horizontal). Turn safety valve 1/4 turn to drain appliance.
8.17.3 Remove Heating Microswitch as 8.18.2.
8.17.4 Unscrew safety valve discharge pipe.
8.17.5 Unscrew complete valve from Heating Manifold.
8.17.6 Replace in reverse order.

- 8.18 REMOVAL OF ELECTRICAL COMPONENTS**
8.18.1 Ensure electricity is switched off at main isolator and gain general access (8.4)
8.18.2 HEATING MICRO SWITCH
Part No 4302
Refer to fig 29
8.18.3 Hold switch and unscrew retaining nut.
8.18.4 Remove switch and remove cover.
8.18.5 Pull off electrical tab connections.
8.18.6 Reassemble in reverse order.
8.18.7 HIGH LIMIT THERMOSTAT
Part No 3409
Refer to fig 32
8.18.8 Gain general access 8.4
8.18.9 Remove room-sealed front cover 8.5.2
8.18.10 Pull off the two electrical connections on the back of the thermostat.
8.18.11 Unscrew the black cap, and remove retaining nut.

- 8.18.12** Trace capillary tube to sensor, withdraw sensor from pocket on main flow tube and carefully pull sensor through the seal in the combustion chamber.
Reassemble in reverse order. Ensuring the sensor is fully located in the pocket.
8.18.14 SAFETY THERMOSTAT
Part number 5447
Refer to figs 32 & 28
8.18.15 Pull off two electrical tab connectors on safety thermostat (marked with a yellow spot)
8.18.16 Ease off thermostat retaining clip.
8.18.17 Reassemble in reverse order.

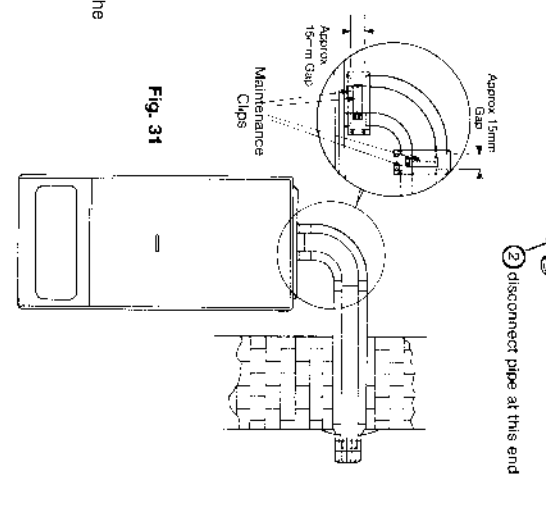
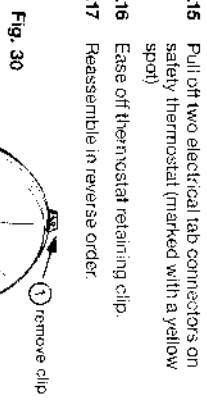

SECTION 9 OPERATIONAL CHECKS, WIRING DIAGRAMS & FAULT FINDING

9.1 On completion of any service/fault finding task which has required the breaking and remaking of electrical connections the checks Earth Continuity, polarity and Resistance to Earth must be repeated. The following flow diagrams suggest the logical sequence of steps for fault finding. They are not exhaustive but cover all that can reasonably be carried out on site by the installer or service engineer.

Acquaintance with the functional sequence will prove helpful for some, and this is included for reference. As further help, the role of each part is briefly described. Also included in this section are wiring diagrams and schematics to assist in fault location and servicing as described in the text.

9.2 SEQUENCE OF FUNCTIONS

When following this sequence, refer to figs 36 & 38. It is assumed that the on/off switch and gas supply are ON. With all controls calling for heat, the pump will run and operate the boiler flow switch. At the same time a supply through the boiler control thermostat (P1-1) via the high limit and safety thermostats will energise terminal 8 on the ignition control. This supply is connected internally to terminal 9 and then in turn to the normally closed terminal (pin 1) of the pressure differential switch.

If the fan is not running due to a fan overrun cycle, an internal latching circuit in the ignition control operates and connects a supply to terminal 10.

NOTE

If the fan is running due to the fan over-run then operation of the boiler flow switch will remove the supply from the fan, allowing it to run down and the cycle to continue. This supply is fed via the boiler flow switch to operate the fan; the fan starting causes the pressure differential switch to change over energising it's normally open contact (pin 2) and in turn terminal 6 of the ignition control. There will be a short delay, followed by the gas valve being energised and the electrode to start sparking.

If a flame is detected during the ignition attempt time (8-12 seconds) the sparking would stop, the gas valve would remain energised and the boiler will produce heat while there is a demand.

If a flame is not detected the boiler will go to lockout (failure to detect a flame during the ignition attempt period). At which time the gas valve will be de-energised and the sparking will stop. To reset the boiler after lockout turn off the boiler on/off switch for at least 5 seconds. When the boiler thermostat is satisfied and P1-1 breaks the boiler circuitry will go to rest, but the pump will remain running to circulate water around the radiators. If the supply to P1 is broken (e.g. by a room thermostat) both the boiler and pump are switched off. However the fan over-run thermostat provides an alternative supply to the fan, keeping it running until the boiler temperature drops to approx 60°C. Should there be a restriction in the heating circuit reducing the flow rate through the boiler to below 350 litres/hour (1.28 gpm) the boiler flow switch will open and de-energise the fan which in turn shuts down the boiler.

8.18.18 HEATING THERMOSTAT

Part No 3267
Refer to figs 32 & 33

8.18.19 Gain general access as 8.4

8.18.20 Remove room-sealed front cover 8.5.2

8.18.21 Trace capillary tube to sensor, remove sensor retaining clip, remove sensor from pocket and carefully pull sensor through rubber seal in combustion chamber.

8.18.22 Pull electrical tabs off back of thermostat.

8.18.23 Pull knob off front revealing 2 retaining screws.

8.18.24 Remove screws to release thermostat

8.18.25 Reassemble in reverse order referring to figs 32 & 33 to ensure correct location of thermostat and push-on wiring tabs.

8.18.26 ELECTRONIC IGNITION CONTROLLER
Part No 5785
Refer to fig 32

8.18.27 Gain general access as 8.4

8.18.28 Pull of cable connector and ignitor lead.

8.18.29 Unscrew 2 retaining screws through front panel, and remove controller.

8.18.30 Reassemble in reverse order.

8.18.31 SWITCHES ON/OFF and TIMED/REST/CONSTANT or MODE SELECTOR
Part No's 5284 & 4980
Refer to fig 34

8.18.32 Pull of tab connectors, squeeze spring latching tabs at the back of the panel and push switch outwards to remove.

8.18.33 To replace refer to fig 34 to ensure switch is in correct attitude and press into hole from the front until spring tabs latch. Refer to fig 34 for correct wiring details.

8.18.34 FAN OVER-RUN THERMOSTAT

Part No 4931
Refer to fig 32

8.18.35 Pull off two electrical tab connectors on thermostat. (NOT marked with yellow spot).

8.18.36 Ease off thermostat retaining clip.

8.18.37 Reassemble in reverse order.

8.19 REMOVAL OF MECHANICAL INSTRUMENTS AND COMPONENTS.

8.19.1 PRESSURE GAUGE
Part No 5263

8.19.2 Close central heating flow and return valves, by 1/4 turn to horizontal position, drain appliance through the safety valve by 1/4 turn of the knob.

8.19.3 Trace capillary from back of gauge to connecting point on heating manifold (fig 29).

8.19.4 Unscrew union on manifold.

8.19.5 Remove and clean off washer remnants.

8.19.6 Squeeze plastic locking lugs behind fascia and press gauge from aperture.

8.19.7 Reassemble in reverse order following original route for capillary.

8.19.8 TEMPERATURE GAUGE
Part No 5262

8.19.9 Trace capillary to sensor. Remove sensor retaining clips and remove sensor.

8.19.10 Squeeze plastic locking lugs behind fascia and press gauge from aperture.

8.19.11 Reassemble in reverse order following original route for capillary.

8.20 END OF SERVICING

Run through the general commissioning as described in Section 6 as far as they apply. Refit casings and clean up.

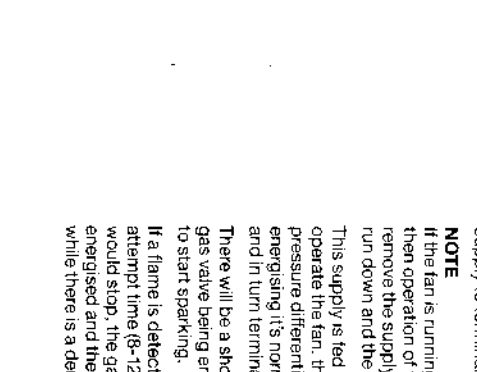
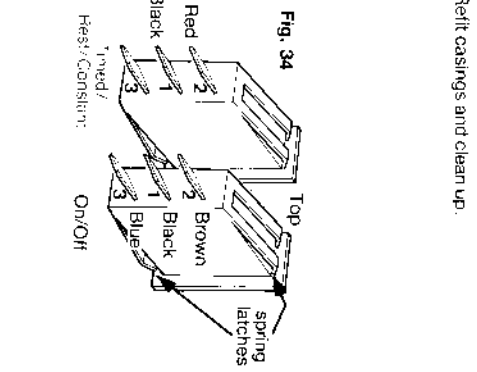
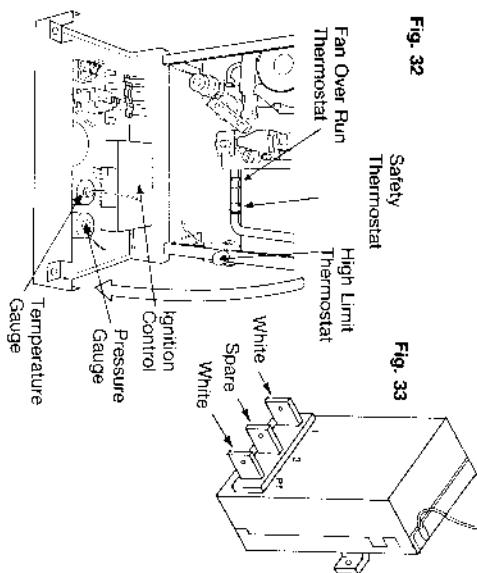

**FAULT FINDING STEP 1
CHECK ELECTRICAL SUPPLIES, SWITCHES & CONNECTIONS**

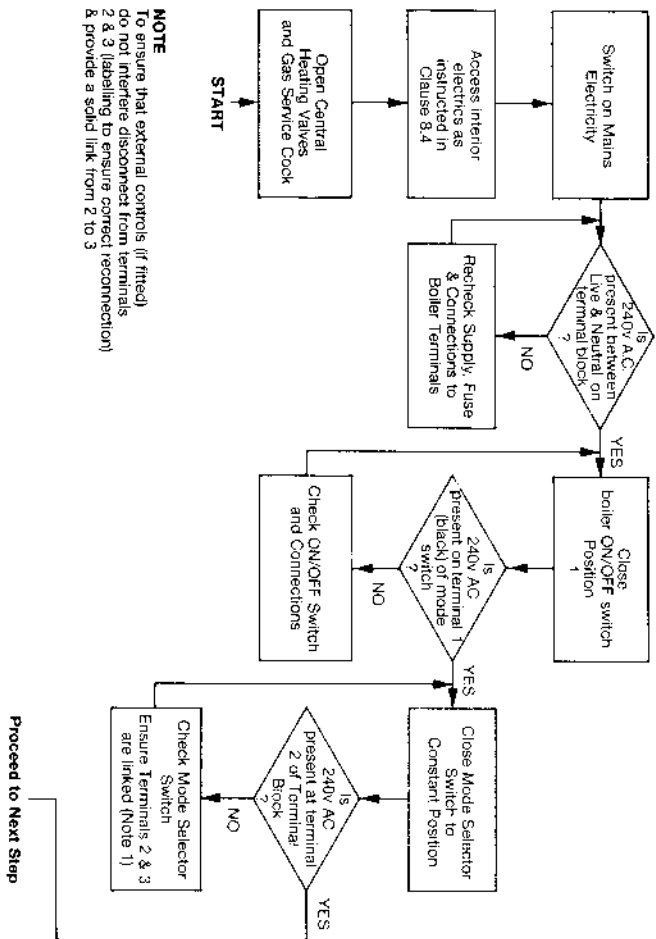

NOTE
To ensure that external controls (if fitted) do not interfere disconnect from terminals 2 & 3 (labelling to ensure correct reconnection) & provide a solid link from 2 to 3

**FAULT FINDING STEP 2
CHECKING C/H THERMOSTAT CIRCUIT**

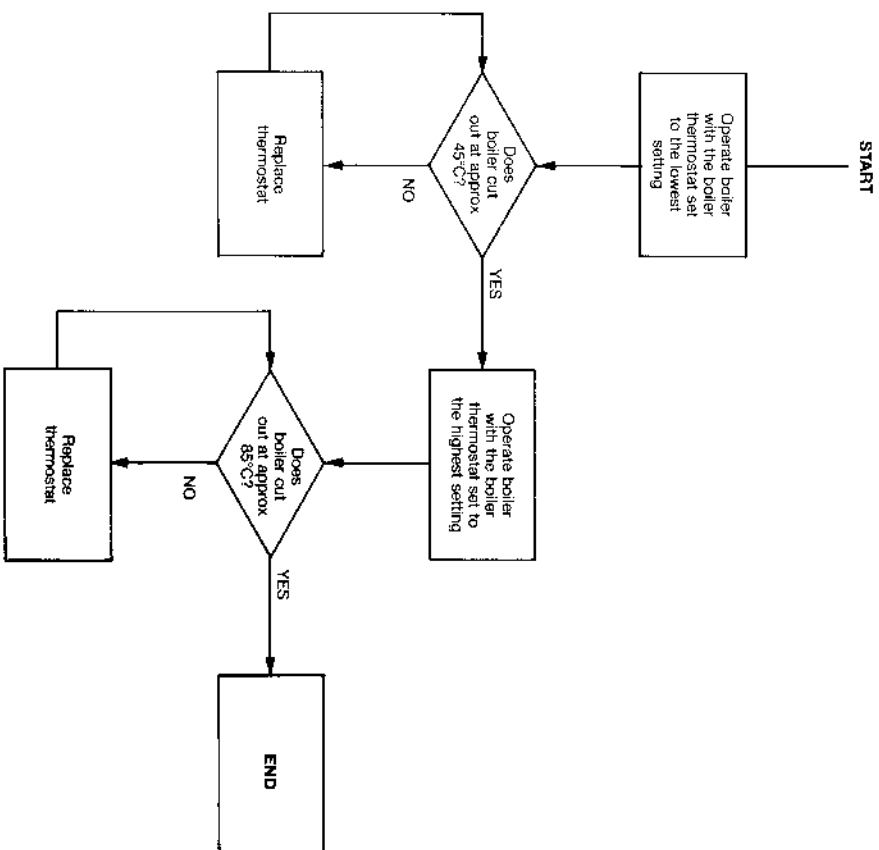

NOTE
1 Reduce number of radiators on to give quick response.

- Instructions for (A) Fitting Yokera 24 Hour Time Switch (Part No. 032 G.C. No. 301 110) and Fitting Yokera Digital 7 Day Time Switch (Part No. 05 G.C. No. 301 109)
 (B) Wiring to external Time Switches, Room Thermostats and Frost Thermostats
 (C) Wiring to 'Y' plan or 'S' plan installations

A. Installation of the Yokera Time Switches (24 Hr and 7 Day)

Remove the clock aperture blanking plate (1) (fig. 1) by squeezing the two lugs on the rear of the plate together and push the plate out.

Remove the clock from it's box.

Wire the clock as shown in fig. 4.

Insert the clock into the aperture from the back of the control panel. Push the mounting bezel (2) through the front panel and secure to the clock using the four screws provided. (fig. 2).

Connect the other ends of the wires to the main terminal block as detailed below. (fig. 3).

Red/White: Push on to spare spade connector on terminal 1.

Blue: Connect to terminal marked 'N'.

Red/Black: Connect to spare terminal on rear of timed/ rest/ constant switch.

White: Connect to terminal 2 on main terminal block, (leave link 2-3 connected if no room thermostat is used).

Remove the loop between terminals 2 & 3 on the boiler terminal block. (A room stat is also fitted).

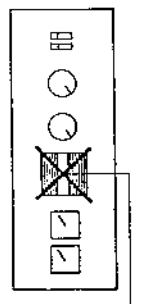

Fig. 1

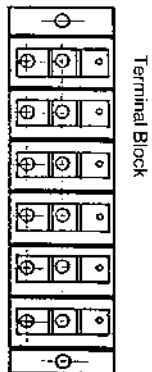

Fig. 3

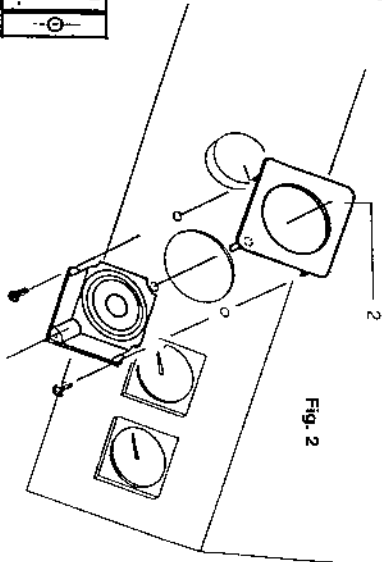

Fig. 2

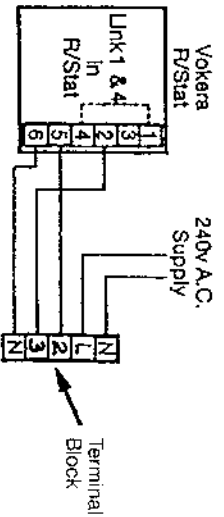
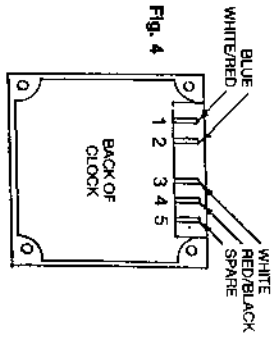

Fig. 4



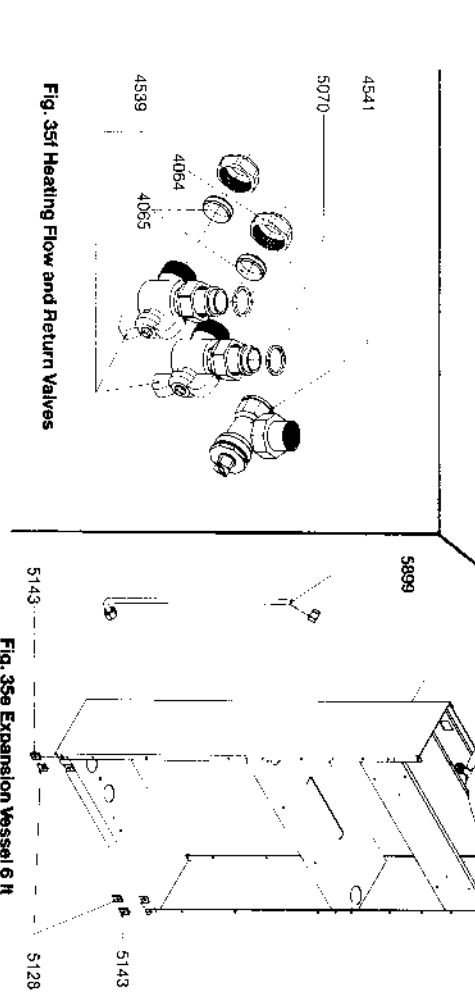
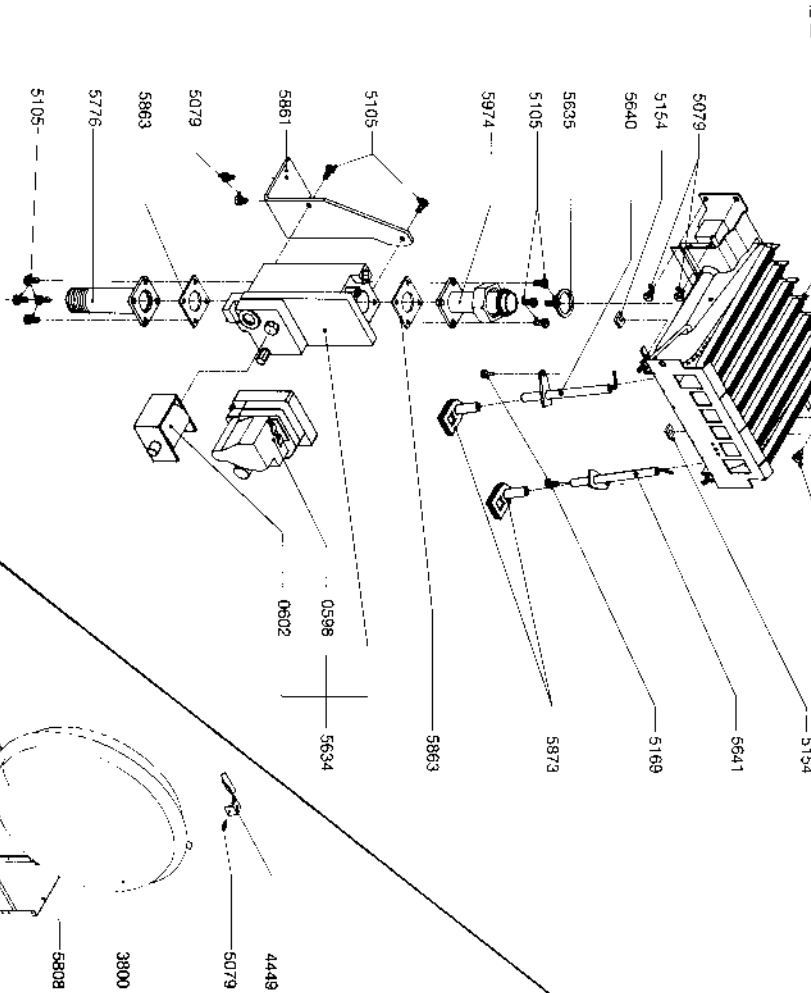
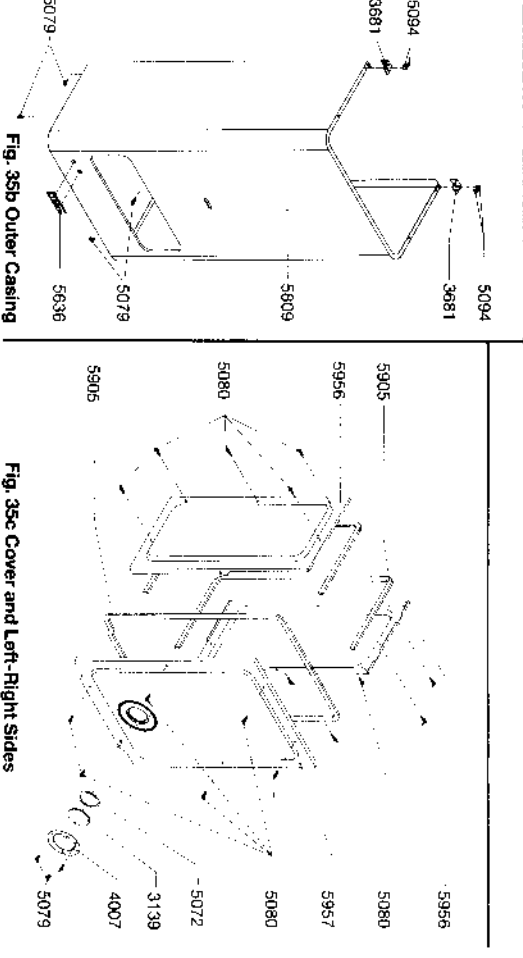
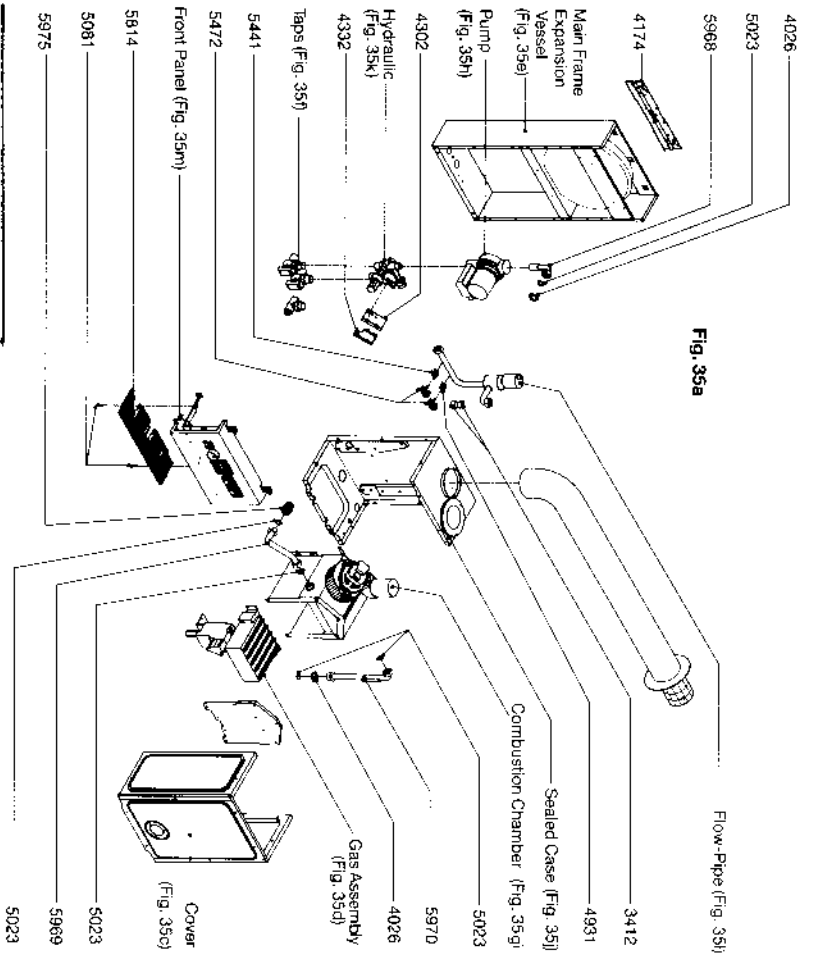
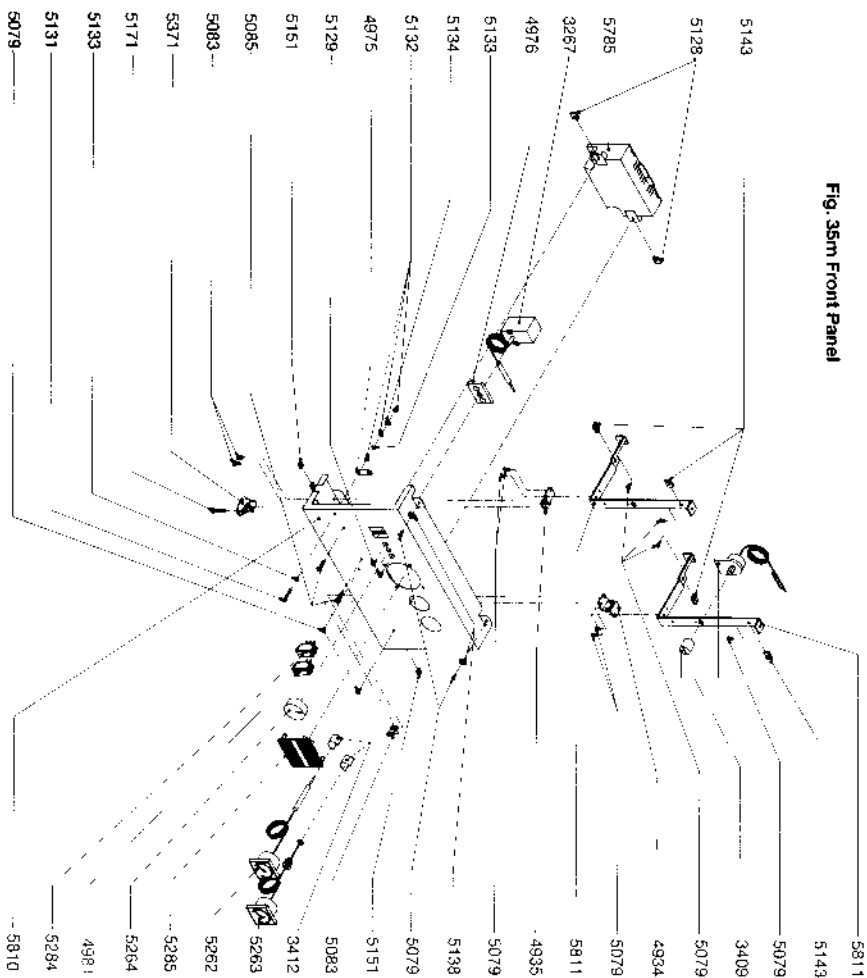

Fig. 35m Front Panel



SHORT SPARE PARTS LIST

Code	G.C. No.	Description	Code	G.C. No.	Description
0557	333 941	Flow switch diaphragm	5284	301 009	On/Off switch
0587	370 348	Main injector 1-35 dia	5441	301 027	Safety Thermostat
0598	333 972	Servo pressure regulator	5634	301 029	Gas valve
0602	333 976	Solenoid	5640	301 034	Spark electrode
3409	333 978	High Limit thermostat	5641	301 035	Sensing electrode
4250	333 772	Safety valve	5785	370 316	Electronic Ignition control
4254	333 722	Automatic Air Vent	5812	370 321	Main Burner
4302	333 773	Single micro switch	5926	301 063	Pressure differential switch
4831	333 899	Over-run thermostat	5963	397 760	Fan
4981	333 961	Switch	6090	333 374	Pump
5262	301 003	Temperature Gauge			
5263	301 004	Pressure Gauge			

FUNCTIONAL FLOW DIAGRAM

Fig. 36

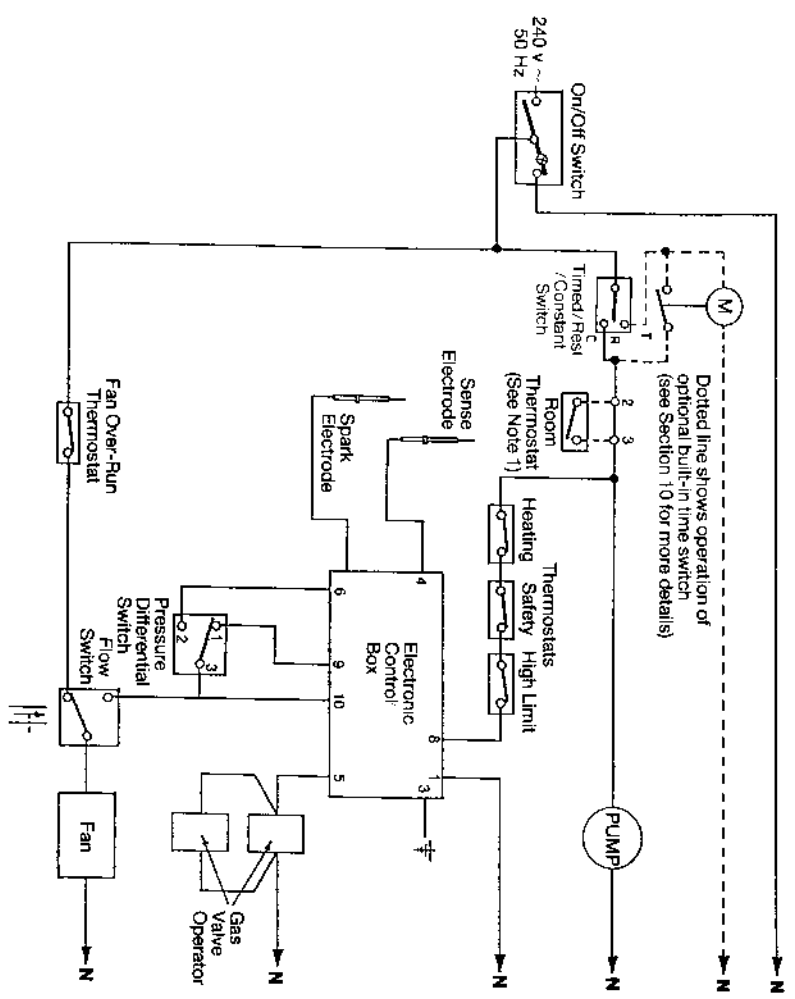

Note If external controls are fitted link 2-3 removed

Fig. 37

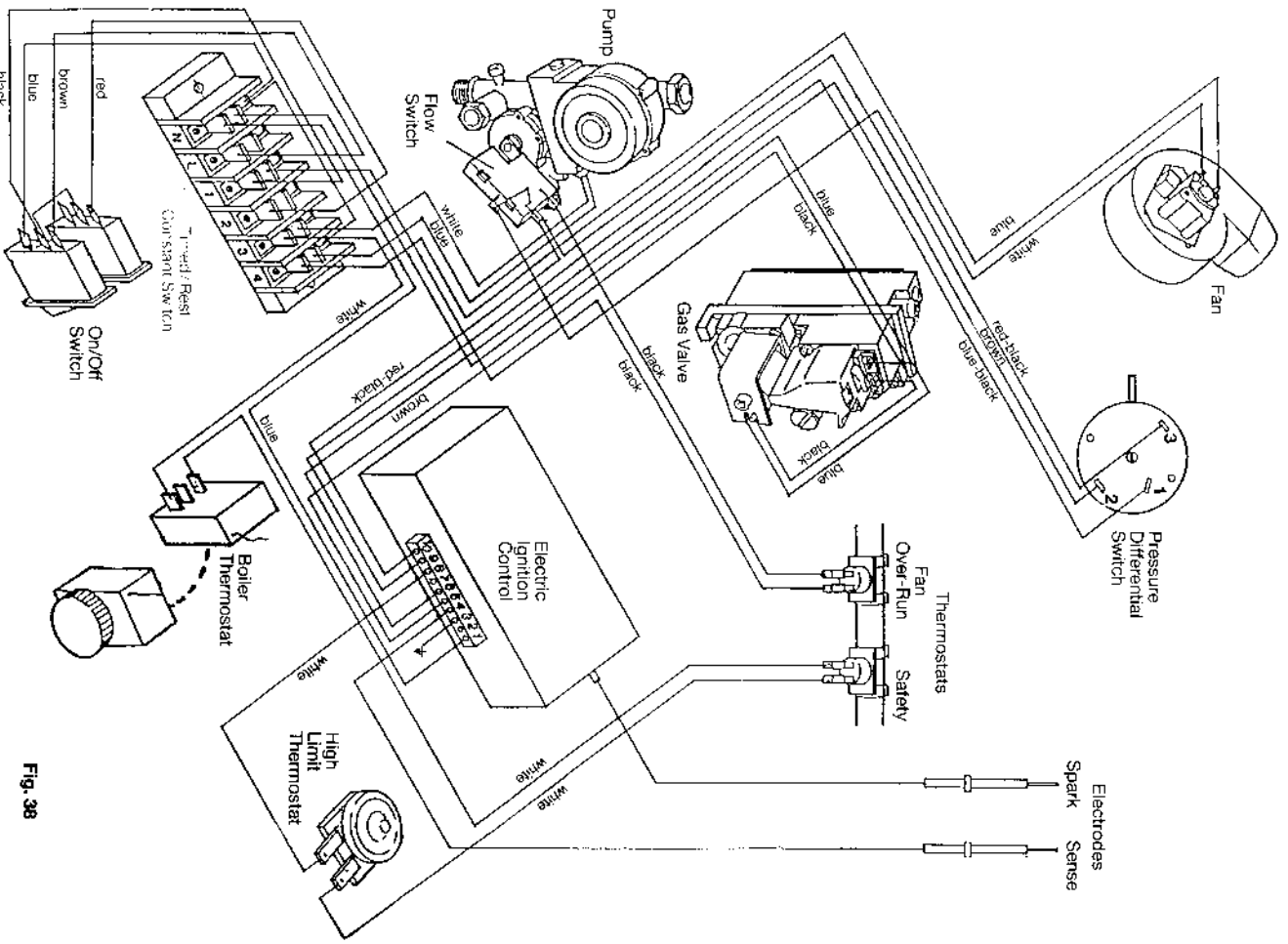
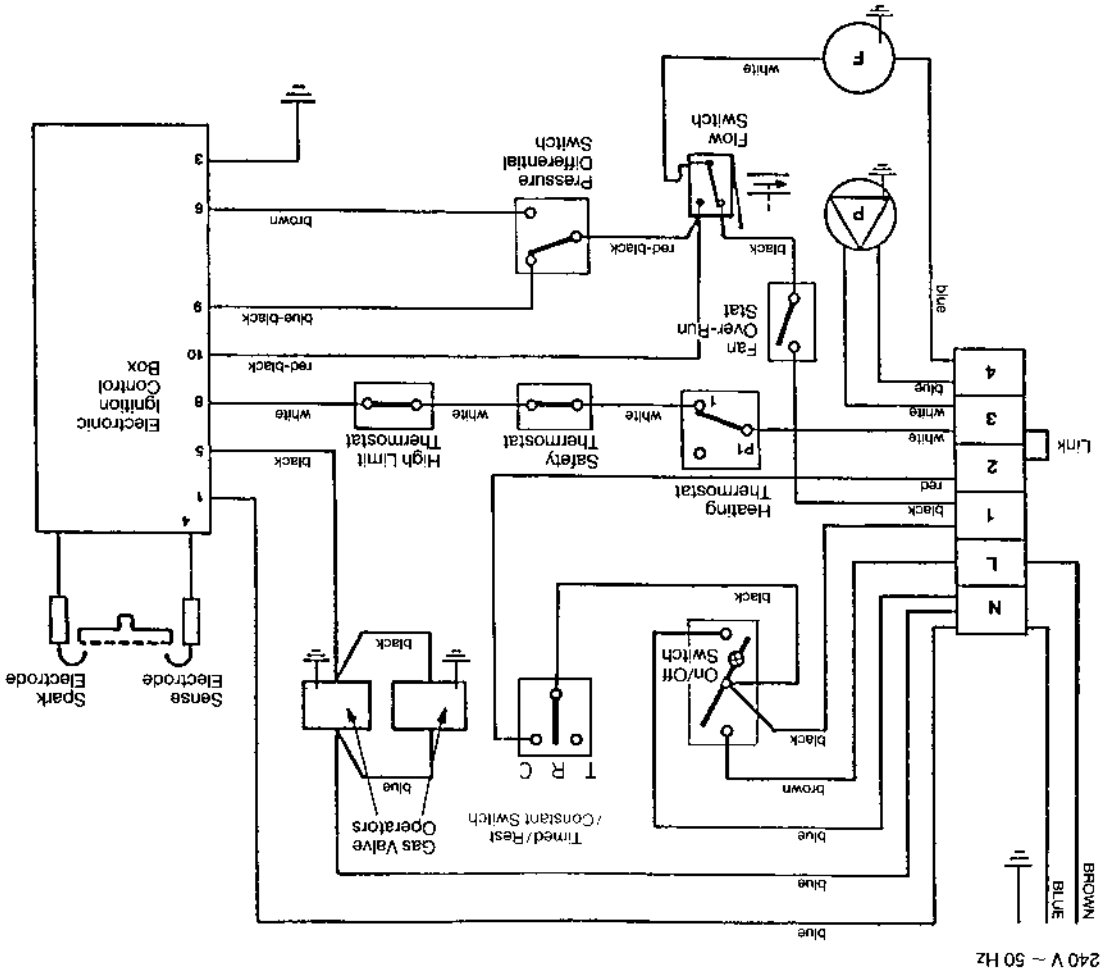

Fig. 38