

Installation, Commissioning and Servicing Instructions

Floor standing RSF gas fired condensing combination boiler

Greenstar Highflow 440CDi ErP & 550CDi ErP

For sealed central heating systems and mains fed domestic hot water

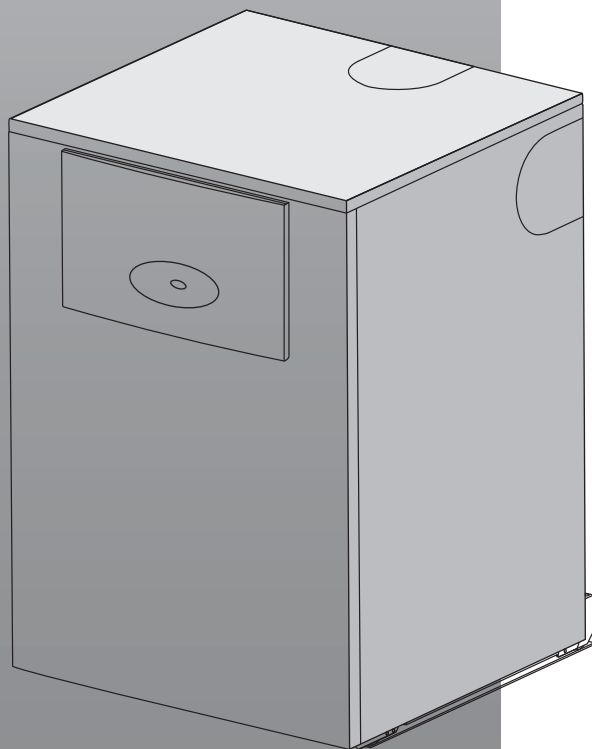

The appliances are for use with:
Natural Gas or L.P.G. (Cat. II 2H3P type C13, C33 & C53)

Natural Gas:
Highflow 440CDi ErP, GC number 47-406-89
Highflow 550CDi ErP, GC number 47-406-91

L.P.G.:
Highflow 440CDi ErP, GC number 47-406-90
Highflow 550CDi ErP, GC number 47-406-92

Contents

1	KEY TO SYMBOLS AND SAFETY PRECAUTIONS	3	6	SERVICING AND SPARES	31
1.1	Key to symbols	3	6.1	Inspection and service	31
1.2	Safety precautions	4	6.2	Service function	32
2	APPLIANCE INFORMATION	6	6.3	Service inspection	32
2.1	General information	6	6.4	Fan pressure test	32
2.2	Technical data	7	6.5	Checking the flue integrity	33
2.3	Product data on energy consumption	8	6.6	Flue gas analysis	33
2.4	Layout and components	9	6.7	Heat exchanger	33
3	PRE-INSTALLATION	11	6.7.1	To clean the burner	33
3.1	Cleaning primary systems	11	6.7.2	To check the flap valve in the fan intake	34
3.2	Mains supply	11	6.7.3	To clean the condensate trap	34
3.2.1	Electrical supply	11	6.7.4	Cleaning the heat exchanger	34
3.2.2	Gas supply	11	6.7.5	Re-assembly of the burner cover	36
3.2.3	Water supply	12	6.8	Setting the air/gas ratio	36
3.3	Water systems and pipe work	12	6.9	Replacement parts	37
3.4	Condensate pipe work	13	6.9.1	Draining the appliance	37
3.4.1	Internal connections	13	6.9.2	PCB Control board	38
3.4.2	External connections	13	6.9.3	Fan assembly:	38
3.5	Pressure relief pipe work	14	6.9.4	Condensate pump	38
3.6	Boiler location and clearances	15	6.9.5	Diverter valve motor	39
3.6.1	Boiler clearances	15	6.9.6	Diverter valve	39
3.6.2	Airing cupboard clearances	15	6.9.7	Pump removal	39
3.6.3	Vented compartments	15	6.9.8	Sample points	39
3.6.4	Rooms containing a bath or shower	16	6.9.9	Sensors	39
3.7	Flue options	16	6.9.10	Domestic hot water heat exchanger	40
3.8	Flue terminal positions	18	6.9.11	Pressure gauge:	40
3.9	Plume management terminal positions	19	6.9.12	Expansion vessel:	40
4	INSTALLATION	20	6.9.13	Pressure relief valve PRV:	40
4.1	Unpacking the boiler	20	6.9.14	Condensate trap	40
4.2	Mounting frame fixing and flue opening	21	6.9.15	Gas valve	41
4.3	Flue opening location	21	6.9.16	Electrode assembly and heatshield	41
4.4	Flue measuring and cutting	22	6.9.17	Burner	41
4.5	Condensate, gas and water connections	23	6.9.18	Primary heat exchanger:	41
4.5.1	Condensate connection	23	6.10	Short parts list	42
4.5.2	Gas and water connections	23	7	FAULT FINDING AND DIAGRAMS	43
4.6	Pressure relief valve outlet	23	7.1	Electrical wiring diagram	43
4.7	Electrical	24	7.2	Central heating function	44
4.7.1	PCB Connections	25	7.3	DHW function	45
5	COMMISSIONING	26	7.4	Protection function	46
5.1	Pre-commissioning checks	26	7.5	Fault finding	47
5.2	Filling the system	26	7.6	Condensate pump Indicator lights	48
5.3	Water treatment	27			
5.4	Starting the appliance	27			
5.4.1	Switching the appliance on/off:	27			
5.4.2	Initialization	28			
5.4.3	Display messages	28			
5.5	Checking gas inlet pressure	28			
5.5.1	Measuring the inlet pressure	28			
5.5.2	Checking the gas rate	29			
5.6	CO and combustion check	30			
5.7	Finishing commissioning	31			

1 KEY TO SYMBOLS AND SAFETY PRECAUTIONS

1.1 Key to symbols

Warnings

	Warnings in this document are identified by a warning triangle printed against a grey background. Keywords at the start of a warning indicate the type and seriousness of the ensuing risk if measures to prevent the risk are not taken.
---	---

The following keywords are defined and can be used in this document:

- **NOTICE** indicates a situation that could result in damage to property or equipment.
- **CAUTION** indicates a situation that could result in minor to medium injury.
- **WARNING** indicates a situation that could result in severe injury or death.
- **DANGER** indicates a situation that will result in severe injury or death.

Important information

	This symbol indicates important information where there is no risk to people or property.
---	---

Additional symbols

Symbol	Explanation
▶	Step in an action sequence
→	Cross-reference to another part of the document
•	List entry
–	List entry (second level)

Table 1

SYMBOLS USED IN THIS MANUAL







	Domestic Hot Water
	Central Heating
	Hot Water Storage Cylinder
	Domestic Cold Water Supply
	Electrical Supply
	Gas Supply

Table 2 Commonly used symbols

PLEASE READ THESE INSTRUCTIONS CAREFULLY BEFORE STARTING INSTALLATION.

These instructions are applicable to the Worcester appliance model(s) stated on the front cover of this manual only and must not be used with any other make or model of appliance.

These instructions apply in the UK and Ireland only and must be followed except for any statutory obligations.

This appliance must be installed by a competent registered gas engineer, such as a **Gas Safe** registered engineer or **British Gas** engineer. Failure to install correctly could lead to prosecution.

If you are in any doubt, contact the Worcester Technical help-line (0330 123 3366).

Please leave these instructions with the completed BENCHMARK CHECKLIST, (or a certificate confirming compliance with IS 813, Eire only) and the user manual with the owner or at the gas meter after installation or servicing.

Distance learning and training courses are available from Worcester.

The BENCHMARK CHECKLIST can be found in the back of this Installation manual.

∅	Diameter
NG	Natural Gas
LPG	Liquid Petroleum Gas
CH	Central Heating
DHW	Domestic Hot Water
HE	Heat exchanger
DCW	Domestic Cold Water
PRV	Pressure Relief Valve
NTC	Negative Temperature Coefficient (sensor)
IP	Ingress Protection
RCD	Residual Current Device
TRV	Thermostatic Radiator Valve
ECV	Emergency Control Valve
WRAS	Water Regulations Advisory Scheme
SEDBUK	Seasonal Efficiency of Domestic Boilers in the UK
ErP	Energy related Products
DWTA	Domestic Water Treatment Association

Table 3 Abbreviations use in this manual

1.2 Safety precautions

Instructions for the target group

These installation instructions are intended for registered gas fitters, plumbers, heating engineers and electricians. All instructions must be observed. Failure to comply with these instructions may result in material damage and/or personal injury, including possible loss of life.

- ▶ Read these installation instructions before installation.
- ▶ Observe safety instructions and warnings.
- ▶ Observe national and regional regulations, technical rules and guidelines.
- ▶ Keep a record of all work carried out.

Determined use

The product is not intended for commercial use.

The product may only be used in a domestic situation for the heating of central heating water and for DHW heating in a closed-loop DHW and heating systems.

Any other use is considered inappropriate. Any damage that may result from misuse is excluded from liability.

If you smell gas

A gas leak could potentially cause an explosion. If you smell gas, observe the following rules:

- ▶ Prevent flames or sparks:
 - Do not smoke, use a lighter or strike matches.
 - Do not operate any electrical switches or unplug any equipment.
 - Do not use the telephone or ring doorbells.
- ▶ Turn off the gas at the meter or regulator.
- ▶ Open windows and doors.
- ▶ Warn your neighbours and leave the building.
- ▶ Prevent anyone from entering the building.
- ▶ Move well away from the building: call the National Gas Emergency Service on 0800 111 999.
- ▶ L.P.G. boilers: Call the supplier's number on the side of the gas tank.

Risk to life from poisoning by flue gas

There is a risk to life from escaping flue gas.

- ▶ Never modify any parts for the flue gas routing.
- ▶ Ensure that flue pipes and gaskets are not damaged.

Installation, commissioning and servicing

Installation, commissioning and servicing must only be carried out by a competent registered gas engineer, such as Gas Safe registered engineer or British Gas engineer.

- ▶ Carry out a gas tightness test after completing work on gas-carrying components.
- ▶ Only use original spares.

Electrical work

Electrical work must only be carried out by a qualified electrician:

- ▶ Before starting electrical work;
 - Ensure that the electricity supply is safely isolated and secured to prevent inadvertent re-connection.
Information on safe isolation can be found in the Health and Safety Executive guidance HSG85.
 - Using test equipment approved to GS38 confirm that the electricity supply is disconnected.
- ▶ Refer to the manufacturer's information when installing other components with Worcester equipment within the system.

Handover to the user

When handing over, instruct the user how to operate the heating system and inform the user about its operating conditions.

- ▶ Explain how to operate the heating system and draw the user's attention to any safety relevant action.

- ▶ Explain that modifications and repairs must only be performed by a competent, registered gas engineer, such as a Gas Safe registered engineer or British Gas engineer.
- ▶ Advise the user to have the system serviced annually by a competent, registered gas engineer, such as a Gas Safe registered engineer or British Gas engineer.
- ▶ Leave the installation instructions with the completed Benchmark Checklist (or a certificate confirming compliance with IS 813, Eire only) and the operating instructions with the user or at the gas meter.

Boiler operation

This appliance can be used by children aged from 8 years and above and persons with reduced physical, sensory or mental capabilities or lack of experience and knowledge, if they have been given supervision or instruction concerning use of the appliance in a safe way and understand the hazards involved. Children shall not play with the appliance. Cleaning and user maintenance shall not be made by children without supervision.

Servicing

Advise the user to have the system serviced annually by a competent, registered gas engineer, such as a Gas Safe registered engineer or British Gas engineer. Approved spares must be used to help maintain the economy, safety and reliability of the appliance.

Important

The service engineer must complete the Service Record on the Benchmark Checklist after each service.



Benchmark places responsibilities on both manufacturers and installers.

The purpose is to ensure that customers are provided with the

correct equipment for their needs, that it is installed, commissioned and serviced in accordance with the manufacturer's instructions by competent persons and that it meets the requirements of the appropriate Building Regulations. The Benchmark Checklist can be used to demonstrate compliance with Building Regulations and should be provided to the customer for future reference.

Installers are required to carry out installation, commissioning and servicing work in accordance with the Benchmark Code of Practice which is available from the Heating and Hot water Industry Council who manage and promote the scheme.

Visit centralheating.co.uk for more information.

Health and safety

The appliance contains no asbestos and no substances have been used in the construction process that contravene the COSHH Regulations (Control of Substances Hazardous to Health Regulations 1988).

Combustion and corrosive materials

Do not store or use any combustible materials (paper, thinners, paints etc.) inside or within the vicinity of the appliance.

Chemically aggressive substances can corrode the appliance and invalidate any warranty.

Fitting and modification

Fitting the appliance and any controls to the appliance may only be carried out by a competent engineer in accordance with the current Gas Safety (Installation and Use) Regulations.

Flue systems must not be modified in any way other than as described in the fitting instructions. Any misuse or unauthorised modifications to the appliance, flue or associated components and systems could invalidate the warranty. The manufacturer accepts no liability arising from any such actions, excluding statutory rights.

Installation regulations

Current Gas Safety (Installation and Use) Regulations:

All gas appliances must be installed by a competent, registered gas engineer, such as a Gas Safe registered engineer or British Gas engineer in accordance with the current regulations.

Failure to install appliances correctly could lead to prosecution.

The appliance must be installed in accordance with, and comply to, the current:

Gas Safety Regulations, IET Regulations, Building Regulations, Building Standards (Scotland) (Consolidation),

Building Regulations (Northern Ireland), local water by-laws,

Health and Safety Document 635 (The Electricity at Work Regulations 1989) and any other local requirements.

EU Regulations No. 811/2013 - Energy Labelling.

British Standards:

Where no specific instruction is given, reference should be made to the relevant British Standard codes of Practice.

- BS7074:1 Code of practice for domestic and hot water supply
- BS6891 Installation of low pressure gas pipe work up to 28mm (R1)
- BS5546 Installation of gas hot water supplies for domestic purposes
- EN12828 Central heating for domestic premises
- BS5440:1 Flues and ventilation for gas appliances of rated heating not exceeding 70kW (net): Flues
- BS5440:2 Flues and ventilation for gas appliances of rated heating not exceeding 70kW (net): Air Supply
- BS7593 Treatment of water in domestic hot water central heating systems
- BS6798 Installation of gas fired boilers of rated input up to 70kW (net)
- BS7671 IET Wiring Regulations

Irish Standards

The current relevant Irish standards should be followed, including:

- ECTI National rules for electrical installations
- IS 813 for Domestic Gas Installations.

LPG Installations

An appliance using LPG must not be installed in a room or internal space below ground level unless one side of the building is open to the ground.

Timber framed building:

Where the boiler is to be fitted to a timber framed building the guidelines laid down in BS5440: Part 1 and IGE "Gas Installations in Timber Frame Buildings" should be adhered to.

Potable water:

All seals, joints and compounds (including flux and solder) and components used as part of the secondary domestic water system must be approved by WRAS.

CH Water:

Artificially softened water must not be used to fill the central heating system.

2 APPLIANCE INFORMATION

2.1 General information

BOILER FEATURES AND CHECKLIST

- Pre-wired and pre-plumbed
- Galvanised steel inner frame
- Digital control system
- Sense II Intelligent controls
- Automatic ignition
- Direct burner ignition electrodes
- Built-in frost protection
- Built-in fault finding diagnostics
- Modulating automatic gas valve
- Combustion air fan with speed regulator
- CH temperature sensor and control
- Pump anti-seizure protection
- Flue gas temperature sensor
- Condensate trap and pump
- DHW flow sensor and temperature control
- Plate type DHW heat exchanger

CHECK LIST	
- LITERATURE PACK:	Qty.
Greenstar 440CDi ErP & 550CDi ErP Installation, Commissioning and Servicing Instructions	1
Users Instructions	1

Table 4 Literature pack - checklist

CHECK LIST	
- HARDWARE PACK:	Qty.
Sealing Pack:	1
- Compression Nut 22mm	5
- Compression Ring 22mm	5
- Seal 23.9 x 17.2 x 1.5	4
- Bonded Washer	1
Hose terminal connector	1
Condensate outlet adapter	1
Condensate hose clips	4
Condensate hose clip	1
Sheet metal screw	1

Table 5 Installation pack - checklist

STANDARD PACKAGE:

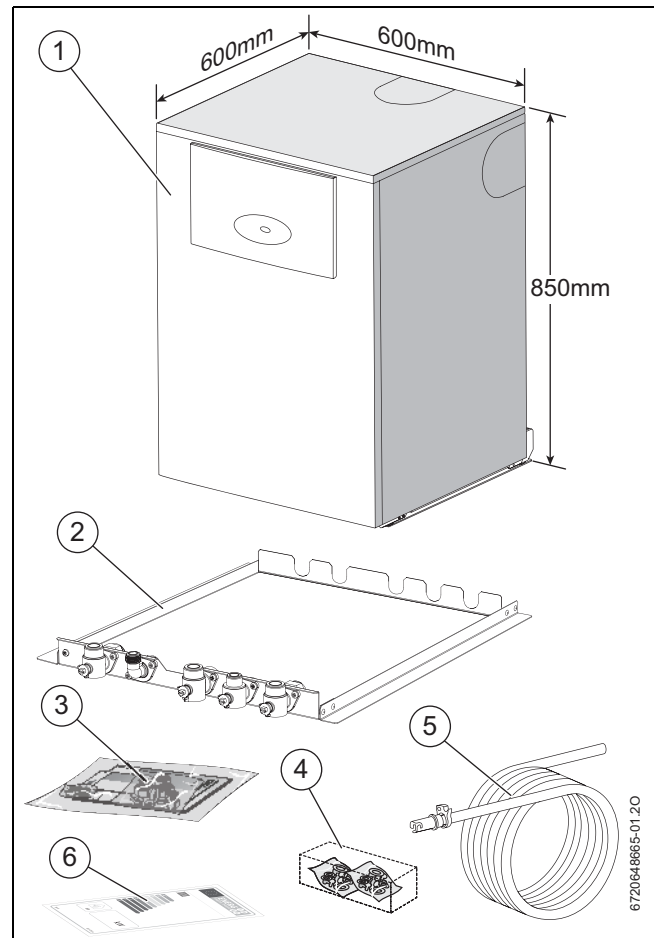

Fig. 1 Standard package

- [1] Floor standing gas fired combination boiler for central heating and domestic hot water.
- [2] Mounting frame complete with pre-plumbing manifold assembly.
- [3] Literature pack.
- [4] Hardware pack.
- [5] Condensate waste pipe and non-return valve.
- [6] ErP energy label

2.2 Technical data

DESCRIPTION	UNITS	Natural Gas		L.P.G	
		440CDi ^{ErP}	550CDi ^{ErP}	440CDi ^{ErP}	550CDi ^{ErP}
Central Heating					
Max. rated heat output net 40/30°C	kW	31.2	32.8	31.2	32.8
Max. rated heat output net 50/30°C	kW	30.9	32.5	30.9	32.5
Max. rated heat output net 80/60°C	kW	29.2	30.6	29.2	30.6
Max. rated heat input net	kW	29.6	31	29.6	31
Min. rated heat output net 40/30°C	kW	8.4	11	11.6	13.4
Min. rated heat output net 50/30°C	kW	8.3	10.9	11.4	13.2
Min. rated heat output net 80/60°C	kW	7.4	9.7	10.5	12.1
Min. rated heat input net	kW	7.6	10	10.8	12.5
Max. flow temperature	°C	88	88	88	88
Max. permissible operating pressure	bar	2.5	2.5	2.5	2.5
Domestic Hot Water					
Max. rated heat input net	kW	29.6	41.5	29.5	41.5
Max. rated heat output	kW	29.5	41.1	29.2	41.1
Minimum flow rate to start	l/min	2.3	2.8	2.3	2.8
Minimum pressure for max flow rate 20 l/min (±15%) with restrictor	bar	2.7	-	2.7	-
Minimum pressure for max flow rate 25 l/min (±15%) with restrictor	bar	-	4.0	-	4.0
Minimum pressure for max flow rate 20 l/min (±15%) w/o restrictor	bar	2.5	-	2.5	-
Minimum pressure for max flow rate 25 l/min (±15%) w/o restrictor	bar	-	3.0	-	3.0
Time to heat tank 15°C to 65°C	mins	13	13	13	13
Gas flow rate - Max. 10 minutes from lighting - (*The Gas Rate provided assumes the accepted NG averaged CV of 1040Btu/ft ³ = 38.76MJ/m ³)					
*Natural gas (network gas)	m ³ /h	3.19	4.29	-	-
Test gas (G20) 1014Btu/ft ³ = 37.78MJ/m ³	m ³ /h	3.27	4.4	-	-
Propane Gas (LPG)	kg/h	-	-	2.3	3.2
Gas supply pressure					
Natural Gas G20	mb	20	20	-	-
LPG (Propane) Gas G31	mb	-	-	37	37
Flue-					
Flue Gas Temp. 80/60°C, rated min. load	°C	67/55	67/55	67/55	67/55
Flue Gas Temp. 40/30°C, rated min. load	°C	43/32	43/32	43/32	43/32
CO2 level at max. rated heat output	%	9.4	9.4	10.8	10.8
CO2 level at min. rated heat output	%	8.6	9.0	10.4	10.4
NOx - classification	class	5	5	5	5
Condensate					
Max. condensation rate	l/h	2.7	3.7	2.7	3.7
pH value, approx.		4.8	4.8	4.8	4.8
Electrical - Class I equipment (must be earthed)					
Electrical power supply voltage	AC...V	230	230	230	230
Frequency	Hz	50	50	50	50
Max. power consumption	W	164	206	164	206
Expansion Vessel					
Charge Pressure	bar	0.75	0.75	0.75	0.75
Total Capacity	ltr	12	12	12	12
General Data					
SAP 2009 annual efficiency	%	89.2	89.2	90.2	90.2
SAP 2005 seasonal efficiency (SEDBUK)	%	90.8	90.8	92.2	92.2
Appliance protection rating	IP	X4D	X4D	X4D	X4D
Appliance protection rating with mechanical timer or MT10RF	IP	20	20	20	20
Appliance protection rating with Sense controls fitted into fascia	IP	X2D	X2D	X2D	X2D
Permissible ambient temperatures	°C	0 - 50	0 - 50	0 - 50	0 - 50
Nominal capacity of appliance	ltr	51	51	51	51
Weight (excluding packaging)	kg	112	112	112	112

Table 6 Technical data

2.3 Product data on energy consumption

The following product data satisfies the requirements of the EU Regulations No. 811/2013, No. 812/2013, No. 813/2013 and No. 814/2013 supplementing Directive 2010/30/EU.

Product data	Symbol	Unit	7731600098	7731600099	7731600100	7731600101
Product type	-	-	440CDi ^{ErP}	440CDi ^{ErP} LPG	550CDi ^{ErP}	550CDi ^{ErP} LPG
Condensing boiler	-	-	Yes	Yes	Yes	Yes
Combination heater	-	-	Yes	Yes	Yes	Yes
Rated heat output	P _{rated}	kW	30	30	31	31
Seasonal space heating energy efficiency	η _s	%	92	92	92	92
Energy efficiency class	-	-	A	A	A	A
Useful heat output						
At rated heat output and high temperature regime ¹⁾	P ₄	kW	29.6	29.6	31.0	31.0
At 30 % of rated heat output and low temperature regime ²⁾	P ₁	kW	9.6	9.6	10.0	10.0
Useful efficiency						
At rated heat output and high temperature regime ¹⁾	η ₄	%	88.5	88.5	88.5	88.5
At 30 % of rated heat output and low temperature regime ²⁾	η ₁	%	97.1	97.1	97.1	97.1
Auxiliary electricity consumption						
At full load	e _{lmax}	kW	0.041	0.041	0.042	0.042
At part load	e _{lmin}	kW	0.018	0.018	0.018	0.018
In standby mode	P _{SB}	kW	0.004	0.004	0.004	0.004
Other items						
Standby heat loss	P _{stby}	kW	0.053	0.053	0.053	0.053
Emissions of nitrogen oxides	NOx	mg/kWh	23	23	23	23
Sound power level, indoors	L _{WA}	dB(A)	53	53	52	52
Additional data for combination heaters						
Declared load profile	-	-	XL	XL	XL	XL
Daily electricity consumption	Q _{elec}	kWh	0.350	0.350	0.357	0.357
Annual electricity consumption	AEC	kWh	77	77	79	79
Daily fuel consumption	Q _{fuel}	kWh	27.356	27.356	28.047	28.047
Annual fuel consumption	AFC	GJ	1,672	1,672	1,714	1,714
Water heating energy efficiency	η _{wh}	%	72	72	71	71
Water heating energy efficiency class	-	-	B	B	B	B

Table 7 Product data for energy consumption

- 1) High temperature regime means 60 °C return temperature at heater inlet and 80 °C flow temperature at heater outlet.
- 2) Low temperature means for condensing boilers 30 °C, for low-temperature boilers 37 °C and for other heaters 50 °C return temperature (at heater inlet).

2.4 Layout and components

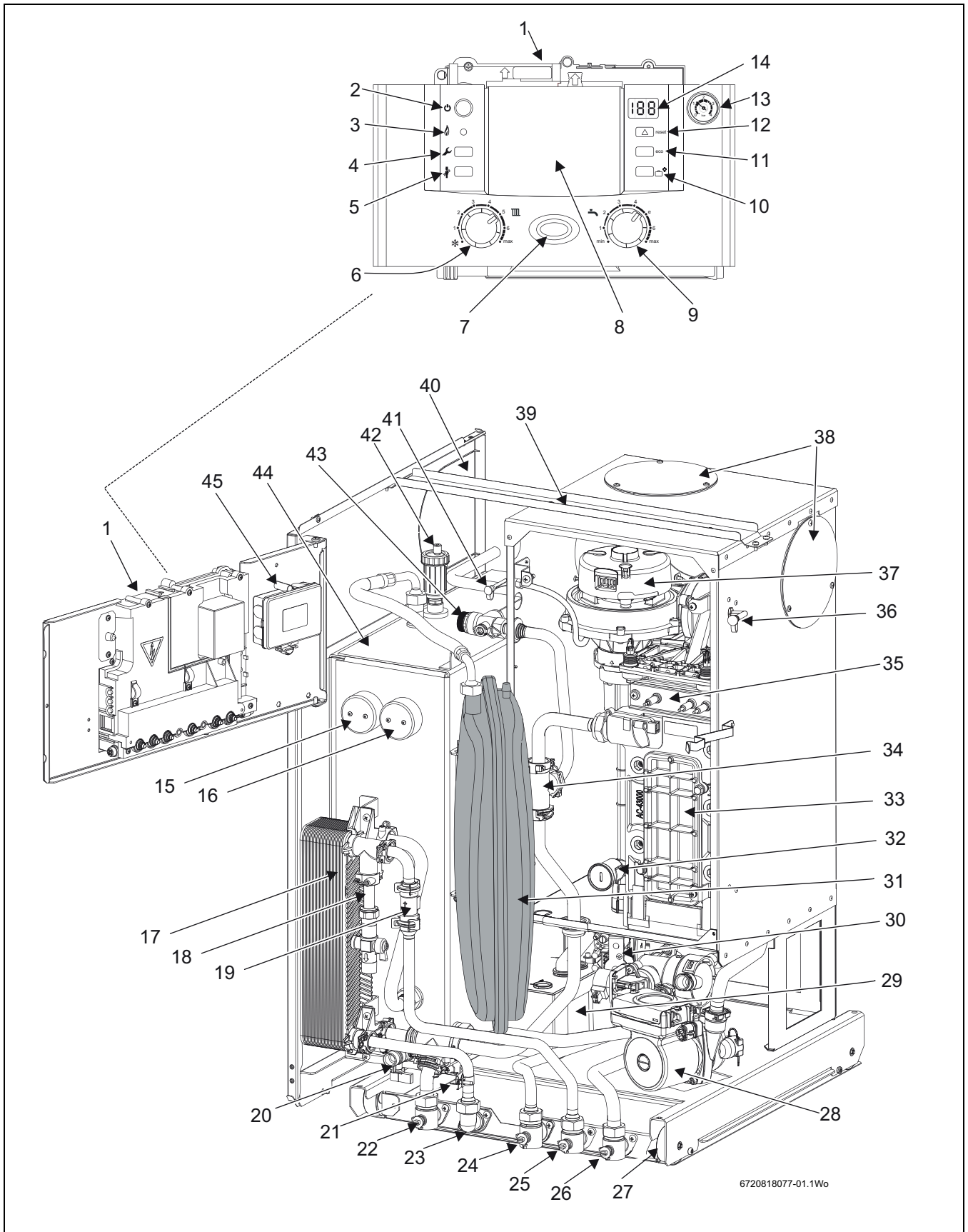



Fig. 2 Appliance layout

1	Control panel
2	230V master switch for ON/OFF
3	Burner ON indicator light (green)
4	Service menu button
5	Service engineer button
6	CH Temperature control
7	230V mains ON/OFF indicator & fault diagnostic light
8	Position for optional programmer
9	DHW Temperature control
10	Not used
11	ECO button
12	Reset button
13	System pressure gauge
14	Display
15	Tank temperature sensor
16	Tank overheat thermostat
17	DHW Heat exchanger
18	Filling loop isolation valve
19	Water flow sensor turbine
20	Boiler/tank drain & connection point for filling loop
21	DHW Temperature sensor
22	CH Flow isolation valve
23	DHW Outlet
24	Gas isolation valve
25	Mains water inlet isolation valve
26	CH Return isolation valve
27	Runner wheel on mounting frame
28	Low energy circulation pump
29	Condensate pump assembly
30	Gas valve
31	Expansion vessel
32	Air/Gas adjustment screw (sealed)
33	Heat cell
34	CH Flow tee piece
35	Gas burner/spark electrodes
36	Air sample point
37	Combustion air modulating fan
38	Flue blanking plates
39	Casing support strut
40	Case 'knock out' panel - flue
41	Flue gas sample point
42	Auto air vent
43	System pressure relief valve
44	Heat store
45	Installer module protective cover

Table 8 Appliance layout

3 PRE-INSTALLATION

3.1 Cleaning primary systems

 **NOTICE:** Before installation

- ▶ All the following Pre-Installation sections must be read and requirements met before starting boiler or flue installations.

 **CAUTION:** ISOLATE THE MAINS ELECTRICITY SUPPLY

- ▶ Ensure that the 230V electricity supply is safely isolated and secured to prevent inadvertent re-connection. Information on safe isolation can be found in the Health and Safety Executive guidance HSG85. Using test equipment approved to GS38 confirm that the electricity supply is disconnected.

 **NOTICE:** Protect the boiler

- ▶ Debris from the system can damage the boiler and reduce efficiency. Failure to comply with the guidelines for the use of water treatment with the appliance will invalidate the appliance warranty.
- ▶ It is recommended that a primary water filter is fitted to the system. Worcester offers two filters that help remove both magnetite and non-magnetic debris; 22mm version, part number 7 733 600 236 and a 28mm version, part number 7 733 600 237.

BEFORE CLEANING THE SYSTEM:

- ▶ Ensure that the system and pipe work is in good working order.
- ▶ Where possible keep the existing boiler/circulating pump in place when flushing the system.
- ▶ FOLLOW THE GUIDANCE OF BS7593: "Treatment of water in domestic hot water central heating"
- ▶ Follow "Flushing the system" guidance given below

 **NOTICE:** ARTIFICIALLY SOFTENED WATER

- ▶ Artificially softened water MUST NOT be used to fill the system

FLUSHING THE SYSTEM

- ▶ Fill the system with cold water and check for leaks.
- ▶ Open all drain cocks and drain the system.
- ▶ Close drain cocks and add a suitable flushing agent **compatible with aluminium** at the correct strength for the system conditions in accordance with the manufacturer's instructions.
The pH value of the system water must be less than 8 or the appliance guarantee will be invalidated.
- ▶ Circulate the flushing agent before the boiler is fired up.
- ▶ Run the boiler/system at normal operating temperature as directed by the manufacturer of the flushing agent.
- ▶ Drain and thoroughly flush the system to remove the flushing agent and debris.
- ▶ It may be necessary to use a power flushing machine to aid the cleansing procedure in some circumstances.
- ▶ Close the drain cocks and refill with fresh water and a suitable inhibitor.
- ▶ Vent any air from the boiler and system.

INHIBITOR

Add a suitable inhibitor or combined inhibitor/anti-freeze, if the system is exposed to freezing conditions, to the heating system in accordance with the DWTa code of practice and manufacturer's guidelines.

Products approved to the BuildCert standard are deemed as compatible with the components and equipment within the boiler and system.

 **WARNING:** Sealing agents

- ▶ The addition of sealing agents to the system water is not permitted as this can cause problems with deposits left in the heat exchanger.
- ▶ In cases where all attempts to find a micro leak have failed, Worcester, Bosch Group supports the use of Fernox F4 leak sealer.

Water treatment

Suitable water treatment products are available from the following manufacturers:

ADEY	01242 546717 www.adey.com
FERNOX	0870 601 5000 www.fernox.com
SENTINEL	0800 389 4670 www.sentinel-solutions.net

Artificially softened water

It is possible to have an ion exchange water softener fitted to the cold water system of the property. However, the boiler requires an untreated cold water connection taken from the mains supply, before the water softener, to the primary water filling point of the heating system.

Alternatively there are water softening/treatment devices that do not adjust or alter the pH levels of the water. With these devices it may not be necessary to provide an untreated water by-pass to the primary water filling point of the heat system.

3.2 Mains supply

3.2.1 Electrical supply

- Supply: 230V - 50 Hz.
- Cable: PVC insulated 0.75 mm² (24 x 0.2mmØ) temperature rated to 90°C. to BS EN50525.
- External 3A fuse to BS1362.
- The appliance must be earthed.
- This appliance must not be connected to a three phase supply.
- IPX4D.
- The wiring between the appliance and the electrical supply must comply with the latest IET wiring regulations that apply to wiring a fixed appliance
- Any system connected to the appliance must not have a separate electrical supply.

 **NOTICE:** IP rating:

- ▶ This is reduced to IP20 if mechanical timers or clip-in weather compensating controller are fitted

- Wiring must comply with the latest IET wiring regulations.

3.2.2 Gas supply

- Boilers using Natural Gas (NG) must be connected to a governed meter.
- Liquid Petroleum Gas (LPG) must be connected to a regulator.
- Installation and connection of the gas supply to the boiler must be in accordance with BS6891.
- Under no circumstance should the size of the gas supply pipe be less than 22mm.
- The meter or regulator and pipe work to the meter or regulator must be checked, preferably by the gas supplier. This is to ensure that the equipment is in good working order and can meet the gas flow and pressure requirements, in addition to the demand from any other appliance being served.

3.2.3 Water supply

WATER MAINS PRESSURE:

- Minimum mains water pressure, for maximum performance **refer to table 6 - Technical data.**
- Maximum mains fed water pressure 10 bar.
If necessary fit a pressure reducing valve.



NOTICE: Non return, flow back prevention devices (including those associated with water meters) fitted to the mains water supply can cause a pressure build up which could damage the boiler and other household appliances.

- Where the mains water supply has a non-return, flow back prevention valve fitted, a mini expansion vessel [1] should be connected to the mains water inlet pipe [2] between the non-return valve [3] and the boiler [4] as shown below.

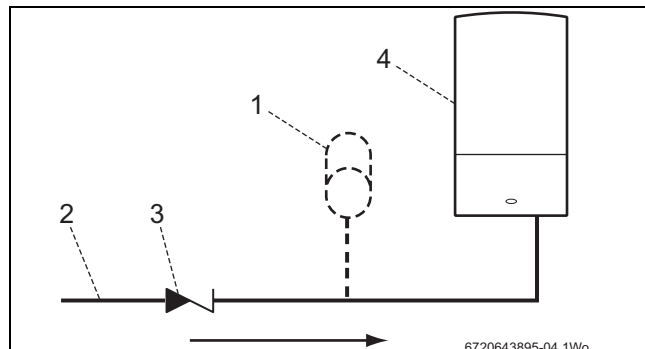

Fig. 3 Mains water pressure

1	Mini expansion vessel - part no. 7 716 192 105
2	Mains water inlet pipe
3	Non return valve
4	Boiler

USE IN HARD WATER AREAS:

Normally there is no need for water treatment to prevent scale formation as the maximum temperature of the HW heat exchanger is limited by the electronic control.

In areas where temporary water hardness exceeds 200ppm, consideration may need to be given to the fitting of a scale prevention device. In such circumstances, the advice of the local water authority should be sought.

3.3 Water systems and pipe work

PRIMARY SYSTEM PLASTIC PIPEWORK:

- Any plastic pipe work must have a polymeric barrier with 600mm (minimum) length of copper connected to the boiler.
- Plastic pipe work used for under floor heating must be correctly controlled with a thermostatic blending valve limiting the temperature of the circuits to approximately 50°C. The pipe work from the boiler to the blending valve must be in copper.

PRIMARY SYSTEM/CONNECTIONS/VALVES:

- **Do not use galvanised pipes or radiators.**
- All system connections, taps and mixing valves must be capable of sustaining a pressure of 3 bar.
- Radiator valves should conform to BS2767:10.
- All other valves should conform to BS1010.
- On new installations a TRV should be used on all radiators except the radiator where the room thermostat is sited, this must be fitted with lock-shield valves and left open.
- All installations should have a TRV fitted to radiators within the sleeping accommodation.
- Drain cocks are required at all the lowest points on the system.
- Air vents are required at all high points on the system.

SEALED PRIMARY SYSTEM:

- Where the system volume is more than 100 litres or exceeds 2.5 bar at maximum heating temperature an additional expansion vessel [2] must be fitted as close as possible to the appliance in the central heating return.
- Pressurise the extra expansion vessel [2] to the same value as the built-in expansion vessel - **refer to table 6 - Technical data.**

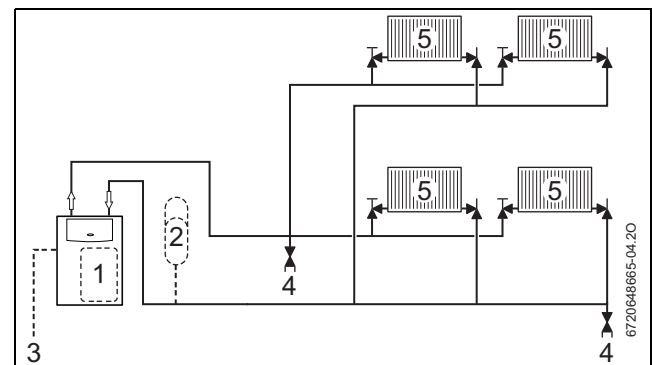

Fig. 4 Typical sealed system

- 1 - Appliance expansion vessel
- 2 - Additional expansion vessel
- 3 - Pressure relief discharge
- 4 - Drain cock
- 5 - Radiators

FILLING PRIMARY SYSTEMS:

- The boiler is fitted with an integral filling loop system and can be used to fill the system.
- The CH sealed system must be filled using a WRAS approved filling loop or comply with the diagram below for external system fill.
- The filling point must be at low level and must never be a permanent direct fixing to the mains water supply.

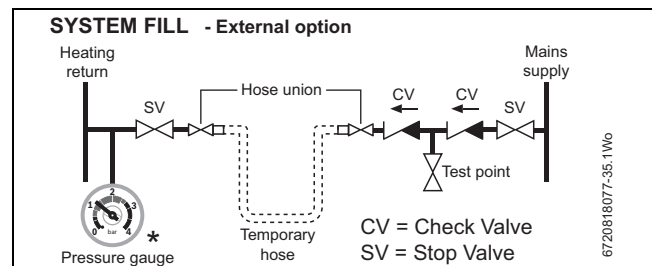

Fig. 5 External filling option

[*] Pressure gauge - If the external filling link is sited away from the boiler, then a pressure gauge should be installed at the filling point

SHOWERS/BIDETS:

- If a shower head can be immersed in water or comes closer than 25mm from the top edge of a bath or shower tray spill over level then an anti-siphon device must be fitted to the shower hose.
- Bidets with direct hot and cold mains water can be used (with the approval of the local water authority) and must be the over rim flushing type with shrouded outlets to prevent the fitting of hand held sprays.

DOMESTIC HOT WATER:

- Taps and mixing valves must be capable of sustaining a pressure up to 10 bar.
- Hot water temperature and flow rate are affected by the size and insulation of pipe work making up the distribution system and are controlled by the hot water tap and the water main inlet pressure. A mixing valve can be fitted if a more permanent temperature setting is required.
- If using more than one outlet at once causes water flow starvation, fit flow balancing valves or Ball-O-Fix valves to the appropriate outlets.

3.4 Condensate pipe work

NOTICE:

- ▶ Where a new or replacement boiler is being installed, access to an internal "gravity discharge" point should be one of the factors considered in determining boiler location.
- ▶ The condensate pipe must be nominally 22mm Ø plastic pipe.
- ▶ The condensate pipe work must fall at least 52mm per metre towards the outlet and should take the shortest practicable route.
- ▶ Ensure there are no blockages in the pipe run.

3.4.1 Internal connections

In order to minimise risk of freezing during prolonged cold spells, the following methods of installing condensate drainage pipe should be adopted, in order of priority.

Wherever possible, the condensate drainage pipe should be routed and terminated so that the condensate drains away from the boiler under gravity to a suitable internal foul water discharge point such as an internal soil and vent stack. A suitable permanent connection to the foul waste pipe should be used.

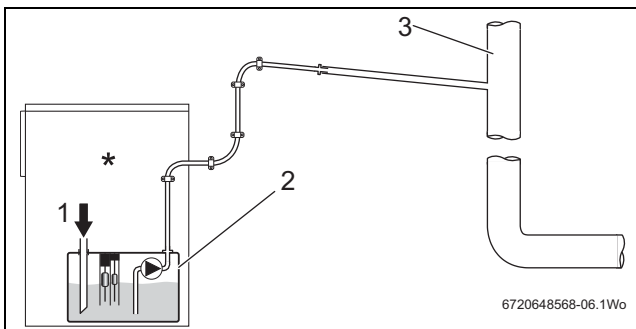

Fig. 6 Disposal to soil vent stack

Alternatively if the first option is not possible an internal kitchen or bathroom waste pipe, washing machine waste pipe etc. can be used.

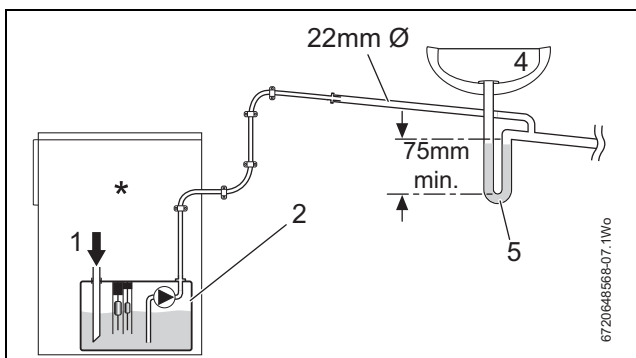

Fig. 7 Disposal to a waste pipe

Key to condensate illustrations	
1	Condensate discharge from boiler
2	Condensate pump within boiler
3	Soil and vent stack
4	Sink or basin with integrated overflow
5	75mm sink waste trap
*	Condensate trap of 75mm already incorporated into the boiler

3.4.2 External connections

NOTICE: Freezing conditions

- ▶ Pipe work length should be kept to a minimum and the route as vertical as possible.
- ▶ Weather proof insulation must be used.

NOTICE: Condensate waste

- ▶ Care should be taken when siting a soak-away to avoid obstructing existing services.

If no other discharge method is possible then the use of an externally run condensate drainage pipe terminating at a suitable foul water discharge point, or purpose-designed soak away, may be considered. If this method is chosen then the following measures should be adopted:

- ▶ The external run be kept as short as possible and not exceed three metres.
- ▶ The pipe should be run internally as far as possible before going externally and the pipe diameter should be increased to 32mm before it passes through the wall to the exterior. The pipe should be insulated using suitable waterproof and weather resistant insulation.
- ▶ The external pipe should take the shortest and least exposed route to the discharge point, and should "fall" as steeply as possible away from the boiler, with no horizontal runs in which condensate might stand.
- ▶ The use of fittings, elbows etc. should be kept to a minimum and any internal "burrs" on cut pipe work should be removed so that the internal pipe section is as smooth as possible.

Fitting an external air break

- Refer to figure 8 when a rain water down pipe is used to dispose of condensate.

NOTICE: Appliance/property damage

- ▶ An air break must be installed in the 43mm pipe work, between the boiler condensate outlet and the drainpipe, outside the property, to avoid appliance/property damage should the down pipe become blocked.

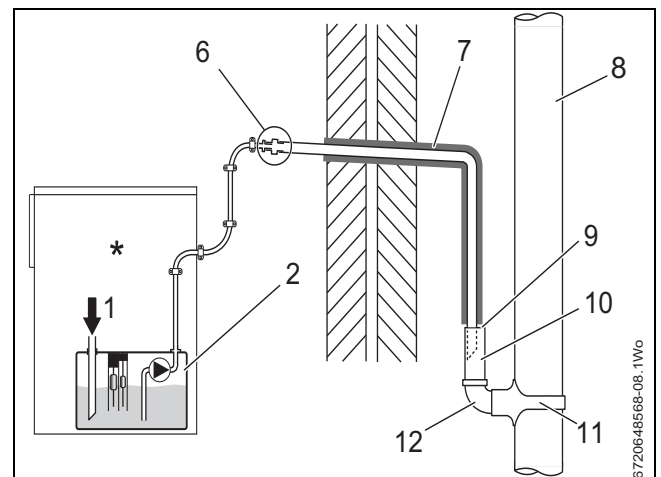

Fig. 8 Disposal into a rainwater down pipe

i Condensate drainage pipe can be run above or below ground.

Where the pipe terminates over an open drain or gully, the pipe should terminate below the grating level, but above water level, in order to minimise "wind chill" at the open end.

The use of a drain cover (such as those used to prevent blockage by leaves) may offer further protection from wind chill.

PRE-INSTALLATION

Pipe drainage will be improved if the end is cut at 45° as opposed to a straight cut.

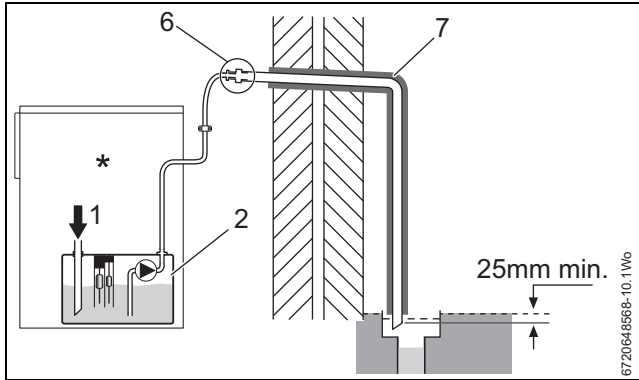

Fig. 9 External disposal

Continued - Key to condensate illustrations	
6	Pipe work transition
7	Insulate and increase pipe size
8	External rain water pipe into foul water
9	External air break
10	Air gap
11	PVCu strap on fitting
12	43mm 90° male/female bend
13	100mm Ø minimum plastic pipe
14	Drainage holes
15	Limestone chippings
16	Bottom of sealed tube
*	Condensate trap of 75mm already incorporated into the boiler

CONDENSATE SOAK AWAY

- The condensate drainage pipe may be run above or below ground to the soak away. The examples shown on this page run above ground.
- The soak away must use a 100mm Ø plastic tube with two rows of three 12mm holes on 25mm centres and 50mm from the bottom of the tube. The holes must face away from the house.
- The tube must be filled with and surrounded by at least 100mm of limestone chippings to a minimum depth of 400mm.



Minimum hole size for the condensate soak away must be 400mm deep by 300mmØ.

In situations where there are likely to be extremes of temperature or exposure, the use of a proprietary trace-heating system for external pipe work, incorporating an external frost thermostat, should be considered. If such a system is used, the requirement to use 32mm pipe does not apply. However, all other guidance above and the instructions for the trace heating system, should be closely followed.



NOTICE: Unheated internal areas.

- ▶ Internal pipe runs in unheated areas such as lofts, basements and garages should be treated as external runs.

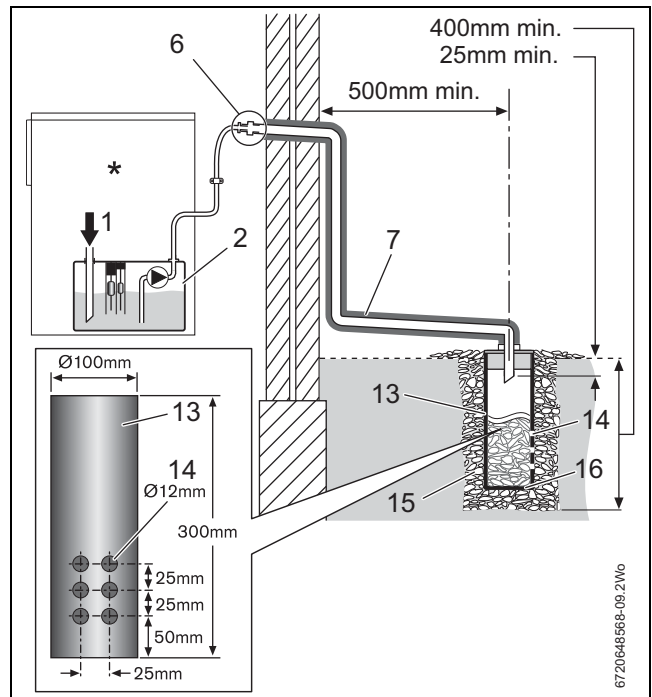

Fig. 10 Soak away

3.5 Pressure relief pipe work



NOTICE: Debris from the system can damage the boiler and reduce efficiency. Failure to comply with the guidelines for the use of water treatment with the appliance will invalidate the appliance warranty.

- The pressure relief drain [1 or 3] should be run in at least 15mm diameter copper pipe or pipe made of a material that will withstand PRV discharge temperatures and pressures and which complies to BS 5252 or BS EN 1451. The connection to the PRV must be made in copper pipe.
- Plastic pipework must be properly supported with a maximum 300 mm between supports to prevent sagging and run downwards away from the boiler and discharge away from any electrical or other hazard, preferably to an external drain or soak-away.
- The pipe [1 or 3] should be finished with a partial bend, near the outlet to face the external wall (as shown) to help prevent freezing.

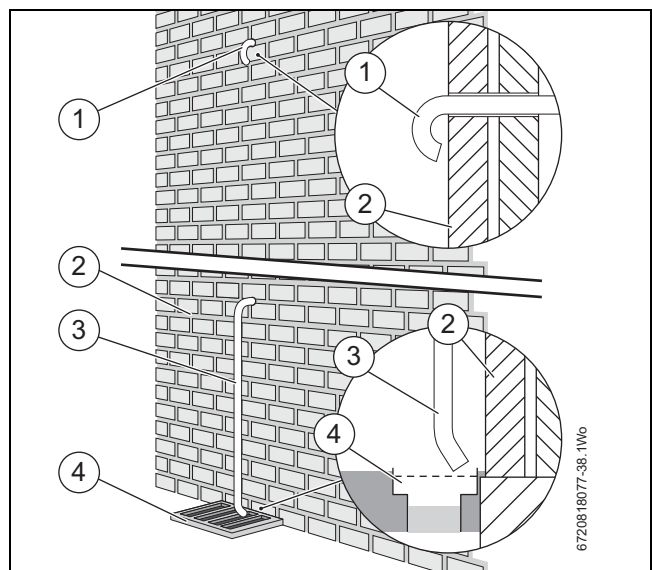

Fig. 11 Pressure relief pipe work

- [2] Outside wall
- [1, 3] Drain pipe
- [4] External drain

3.6 Boiler location and clearances

- This is a floor-standing boiler and is only suitable for installing on the floor, internally in a property
- Install onto a rigid non-combustible surface at least the same size as the boiler and capable of supporting the boiler weight.
- The boiler is not suitable for external installation unless a suitable enclosure is provided.

Compartments

Follow the requirements of BS6798 and BS5440 Part 2 and note:

- Minimum clearances must be maintained.
- An access door is required to install, service and maintain the boiler and any ancillary equipment.
- If fitting the boiler into an airing cupboard use a non-combustible material to separate the boiler from the airing space, that can be perforated with holes up to 13mm.

3.6.1 Boiler clearances

There are several clearances to be considered when either installing or servicing a boiler in an unventilated or ventilated compartment.

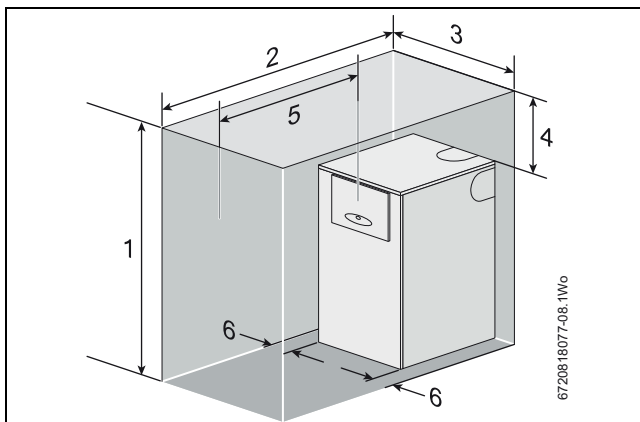

Fig. 12

item	Minimum distance requirements for compartments
1	Overall height of compartment
2	Overall depth of compartment
3	Overall width of compartment
4	Height above the boiler to top of compartment
5	Depth to front of boiler (or shelf)
6	Gap between sides of boiler and compartment
7	Gap between shelf and back of compartment

Clearances

Refer to figure 12 and the table below for the minimum clearances.

item	Compartment clearances (mm)		
	Installation	Servicing	Unventilated
1	1450	865	900
2	1200	1200	800
3	610	610	800
4	600	15	50
5	600	600 ¹⁾	200 ²⁾
6	5	5	100 ³⁾

- 1) Can be reduced to 25mm to a removable door or panel
- 2) Space required with removable door or panel
- 3) Can be reduced to 50mm on one side but maintaining the overall 200mm minimum

3.6.2 Airing cupboard clearances

The dimensions below show the minimum space required to install and service the boiler within an airing cupboard.

If a compartment is built around the boiler after installation, then the compartment must be separated from the boiler space by a non-combustible partition as described in BS 6798.

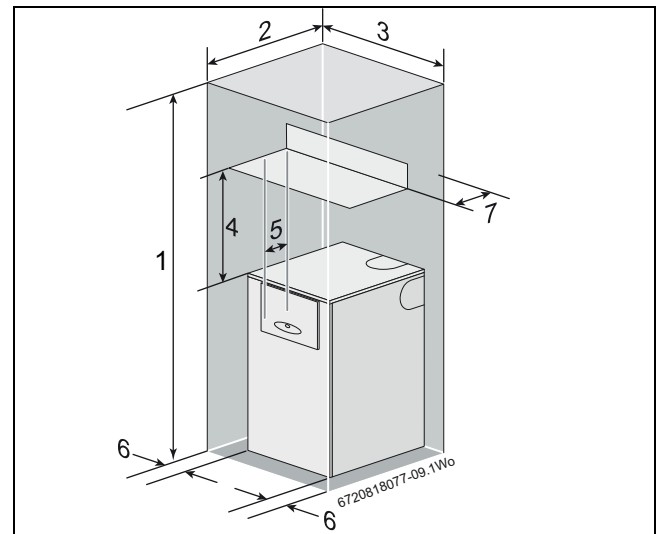

Fig. 13 Airing cupboard clearances

item	Minimum clearances (mm)
1	2300
2	625
3	800
4	200
5	25 ¹⁾
6	100
7	100

- 1) From the front of the boiler and the front of the shelf

3.6.3 Vented compartments

If the clearances available are less than those stated for an unventilated compartment or an airing cupboard then ventilation must be provided as described in BS 5440.

A minimum of two air vents of equal size must be fitted, one at low level and another at high level on the same wall using the same air for circulation.

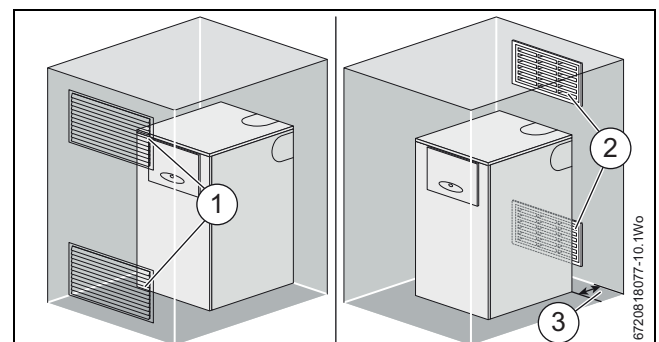

Fig. 14 Venting compartments

item	Boiler	Air source	Minimum area of vent
1	440CDi ^{ErP}	Internal room or space	310cm ²
	550CDi ^{ErP}		440cm ²
2	440CDi ^{ErP}	Outside	155cm ²
	550CDi ^{ErP}		220cm ²
3	All	100mm space between the boiler and vent	

3.6.4 Rooms containing a bath or shower

NOTICE: Any switch or appliance control using mains electricity must not be within reach of a person using the bath or shower.

An appliance fitted with a mechanical, RF mechanical timer, or a clip-in weather compensating controller may be only installed outside the shaded area.

An appliance fitted with a blanking panel or a timer/programmer conforming to IP4XD can be installed in zone 2.

An appliance and programmer combination conforming to less than IP4XD can only be installed outside the shaded area.

BS7671 Amendment 3:2015 requires a 30mA RCD (Residual Current Device) for installations within this location as well as for any circuits passing through zone 1 and/or 2 not serving this location.

If the appliance is installed into a cupboard that opens into zone 1 or 2 it is strongly recommended that a 30mA RCD is fitted to the circuit supplying the boiler.

Refer to the latest IET wiring regulations.

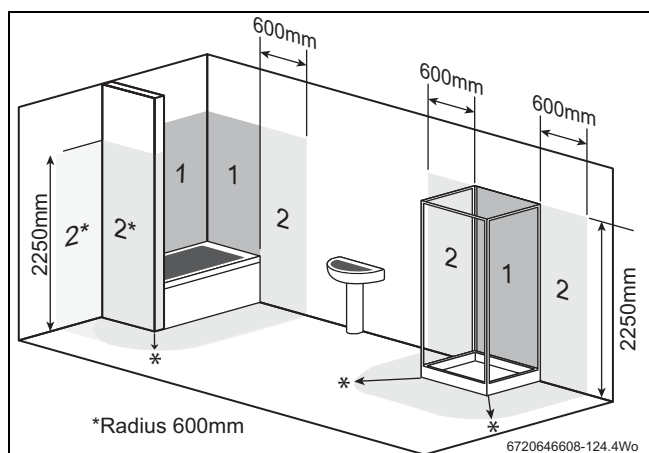

Fig. 15 Bathroom installations

[2*] Without the end wall, zone 2 must extend 600mm from the bath

3.7 Flue options

CAUTION: Non accessible flue systems:

- ▶ Where a flue system is not going to be accessible, provision must be made for service and inspection.
- ▶ Voids containing concealed flues must have at least one inspection hatch no less than 300mm square.
- ▶ Flue joints within the void must not be more than 1.5 metres from the edge of the inspection hatch.
- ▶ Inspection hatches should be located at changes of direction.
- ▶ If this is not possible, bends should be viewable from both directions.

NOTICE: Effective flue lengths of bends:

Each bend used has an equivalent straight flue length

- ▶ refer to the table below

Bend	Effective flue length	
	60/100	80/125
45°	0.75m	1m
90°	1.5m	2m

i Plume management kits are available for the 60/100 horizontal flue system, Part number 7 716 191 086. Refer to the manual supplied with the Plume Management kits for complete installation instructions



Highflow CDi boilers	Maximum total flue length L (mm)	
	60/100	80/125
1 Telescopic horizontal flue assembly	140 ¹⁾ - 530	350 - 1,200
2 Horizontal flue extension	4,000	13,000
3 Horizontal flue with 1 x 90° bend	2,000	11,000
4 Horizontal flue with 2 x 90° bends	N/A	9,000
5 High level horizontal flue	2,000	11,000
6 High level horizontal flue with 2 x 90° bends	N/A	9,000
7 High level horizontal flue with 3 x 90° bends	N/A	7,000
8 Vertical flue assembly	6,400	15,000
9 Vertical flue with 2 x 90° bends	2,400	11,000
10 Vertical flue with 2 x 45° bends	4,400	13,000

Table 9 Flue options

1) Flue is cut to a minimum of 130mm, flue connector adds the additional 10mm. The flue systems have different maximum flue lengths.

The next page shows various flue options.

Refer to the flue options in table 9 for the straight flue lengths required to achieve the maximum flue length.

Part number	Flue	Description
7 716 191 155	60/100	Telescopic horizontal flue assembly
7 716 191 157	80/125	Telescopic horizontal flue assembly
7 716 191 156	60/100	Vertical flue assembly
7 716 191 158	80/125	Vertical flue assembly

Table 10 Flue options

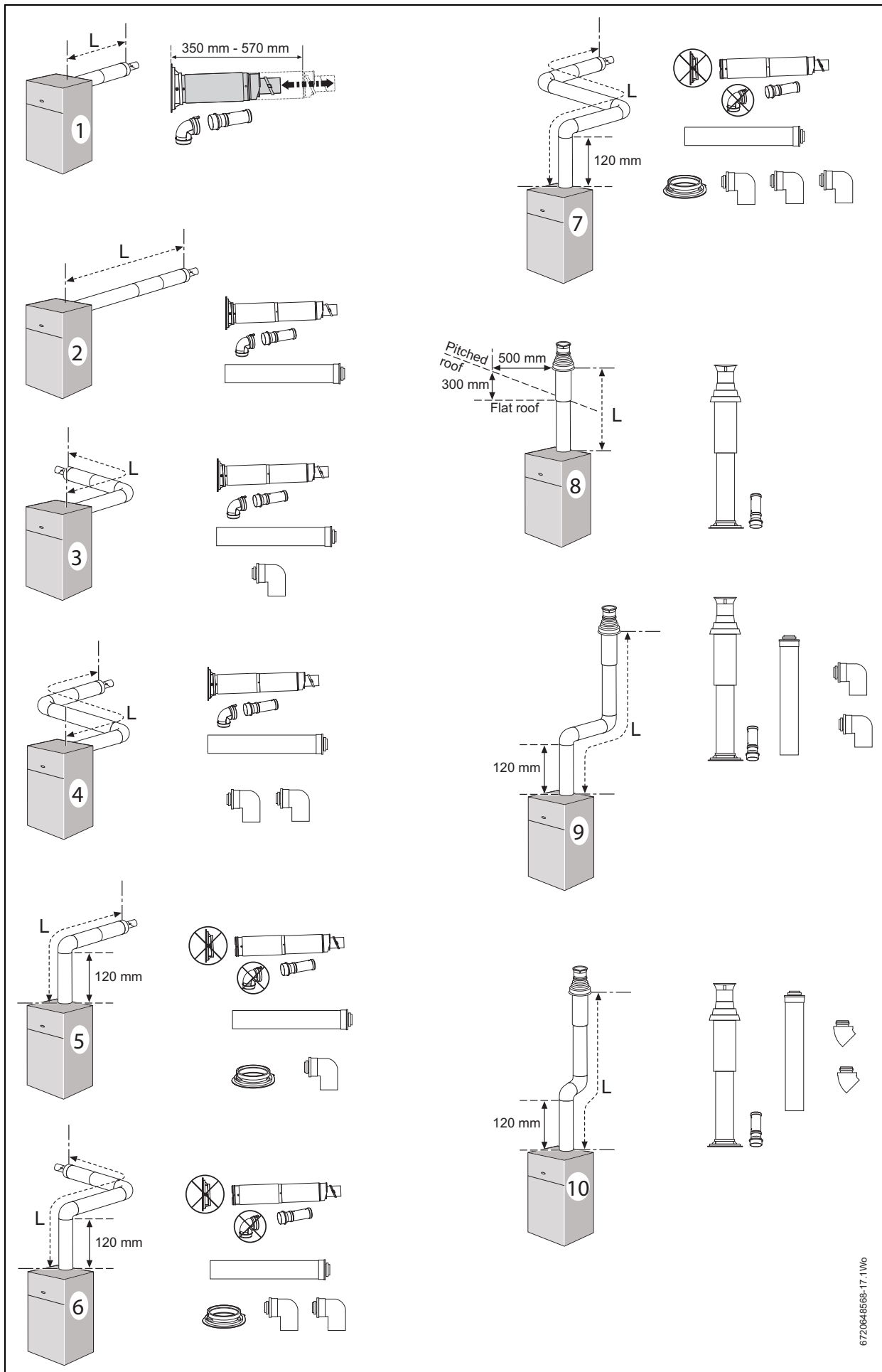

3.9 Plume management terminal positions

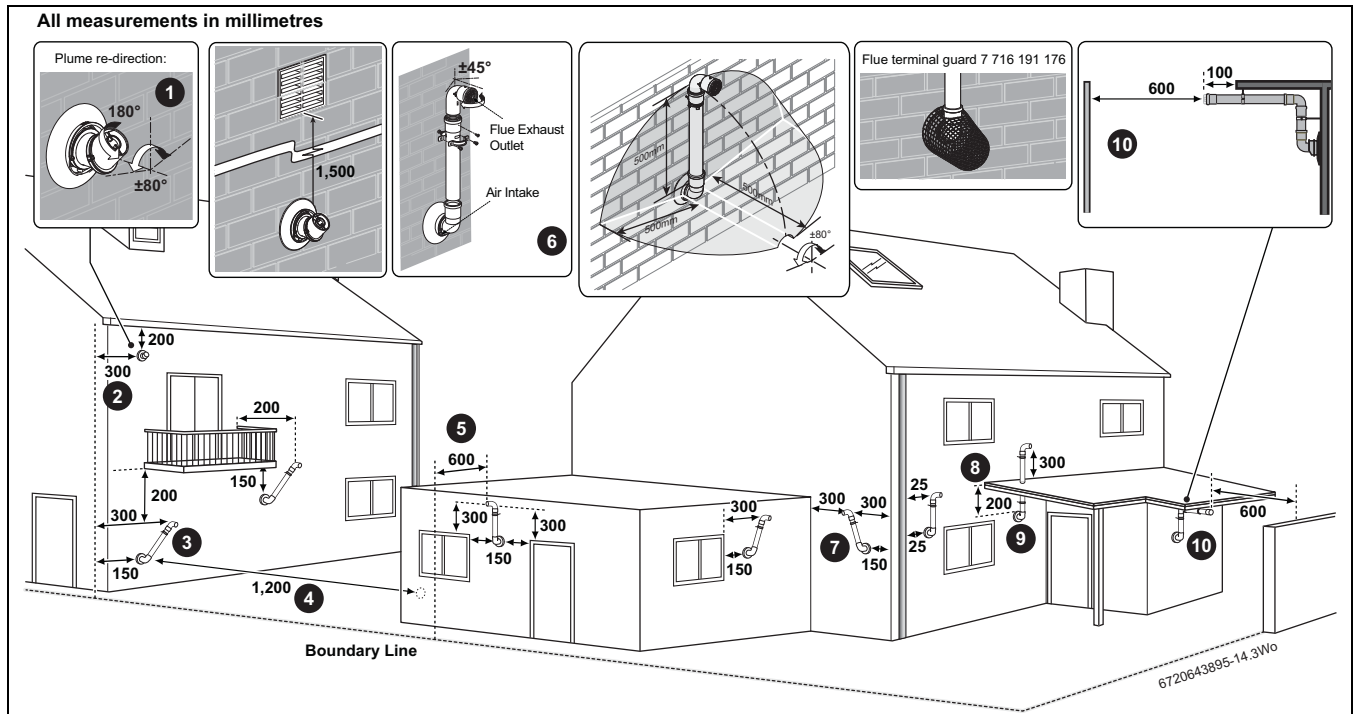

Fig. 17 Plume terminal positions



- Maximum and minimum plume management lengths:
- ▶ A minimum distance of 500mm must be maintained between the plume management outlet and the flue air intake.
 - ▶ The maximum plume management length is 4.5 metres for the appliances detailed on the front of this manual.
 - ▶ The 45° bend is equivalent to 0.75 metres of straight plume management and the 90° bend is equivalent to 1.5 metres.



NOTICE:

- ▶ All measurements are the minimum clearances required.
- ▶ Refer to previous page for all concentric flue terminal positions unless the flue position is specified on the figure above "Plume terminal positions".
- ▶ Terminals must be positioned so to avoid combustion products entering the building.
- ▶ Support the flue at approximately one metre intervals and at a change of direction, use suitable brackets and fittings.

Key to illustration

1. This feature allows some basic plume re-direction options on a standard telescopic horizontal flue terminal. 300mm minimum clearances to an opening e.g. window. However the minimum clearances to an opening in the direction that the plume management is facing, must be increased to 1,500mm. Where the flue is less than 150mm to a drainpipe and plume re-direction is used the deflector should not be directed towards the drainpipe.
2. 300mm adjacent to a boundary line.
3. Plume Management kit air intake can be reduced to 150mm providing the flue exhaust outlet is no less than 300mm adjacent to a boundary line.

4. 1,200mm between terminals facing each other.
5. 600mm distance to a boundary line, unless it will cause a nuisance. BS 5440:Part 1 recommends that care is taken when siting terminal in relation to boundary lines.
6. Using a Plume Management kit the air intake measurement can be reduced to 150mm providing the flue exhaust outlet has a 300mm clearance. Plume kits running horizontally must have at least a 3° fall back to the boiler for proper disposal of condensate, except or the initial horizontal run from the terminal (refer to note opposite).

For details on specific lengths see relevant boiler Technical and Specification information.

7. Internal/external corners. The air intake clearance can be reduced to 150mm providing the flue exhaust outlet has a 300mm clearance.
8. Clearances no less than 200mm from the lowest point of the balcony or overhang.
9. 1,200mm from an opening in a car port on the same wall e.g. door or window leading into the dwelling.
10. 600mm distance to a surface facing a terminal, unless it will cause a nuisance. BS 5440: Part 1 recommends that care is taken when siting terminals in relation to surfaces facing a terminal.



Note:

- ▶ Installations in car ports are not recommended.
- ▶ The flue cannot be lower than 1,000mm from the top of a light well due to the build up of combustion products.
- ▶ Dimensions from a flue terminal to a fanned air inlet to be determined by the ventilation equipment manufacturer.
- ▶ The initial plume kit horizontal run will have at least a 10° fall back to the boiler, due to the terminal elbow design, for proper disposal of the condensate.

4 INSTALLATION

CAUTION: ROOF SPACE

- ▶ THIS BOILER IS NOT SUITABLE FOR ROOF SPACE INSTALLATION.

NOTICE: Boiler start up

- ▶ All the previous Pre-Installation sections must be read and requirements met before starting boiler or flue installation.

4.1 Unpacking the boiler

NOTICE: BOILER HANDLING

- ▶ The correct method for handling heavy objects should be strictly observed, at all times.
- ▶ Take care not to damage the boiler panels or the floor.
- ▶ The boiler may contain some water due to factory testing
- ▶ Store the boiler in a dry area prior to installation

Unpacking:

- ▶ Undo the ties securing the carton to the pallet.
If a sharp implement is used, care must be taken not to pierce the carton or cause injury.
- ▶ Before removing the carton it is advised that the top flaps are opened and the ancillary items [1, 2, 3, 4 & 5] are removed and set to one side.
- ▶ The carton can now be lifted off the boiler.
- ▶ Remove the plastic bag protecting the boiler surfaces and place safely away from the working area.
- ▶ Grip the outer sides of the front panel, pull towards you to release the ball catches and lift away from retaining lugs.
- ▶ Remove the front retaining screw securing the boiler to the pallet.
- ▶ Remove the rear retaining screw securing the boiler to the pallet.
- ▶ The boiler is mounted on small wheels and two people are recommended to move the boiler from the pallet taking care not to damage the panels or the floor.
- ▶ Slide the boiler off the pallet.
- ▶ Pull the plastic strip plug [6] down to remove from the boiler pipe work.

GENERAL HANDLING GUIDELINES:

- ▶ Lift only a manageable weight, or ask for help.
- ▶ When lifting, bend the knees, and keep the back straight and feet apart.
- ▶ Do not lift and twist at the same time. Lift and carry items close to the body
- ▶ Wear protective clothing and gloves to protect from any sharp edges

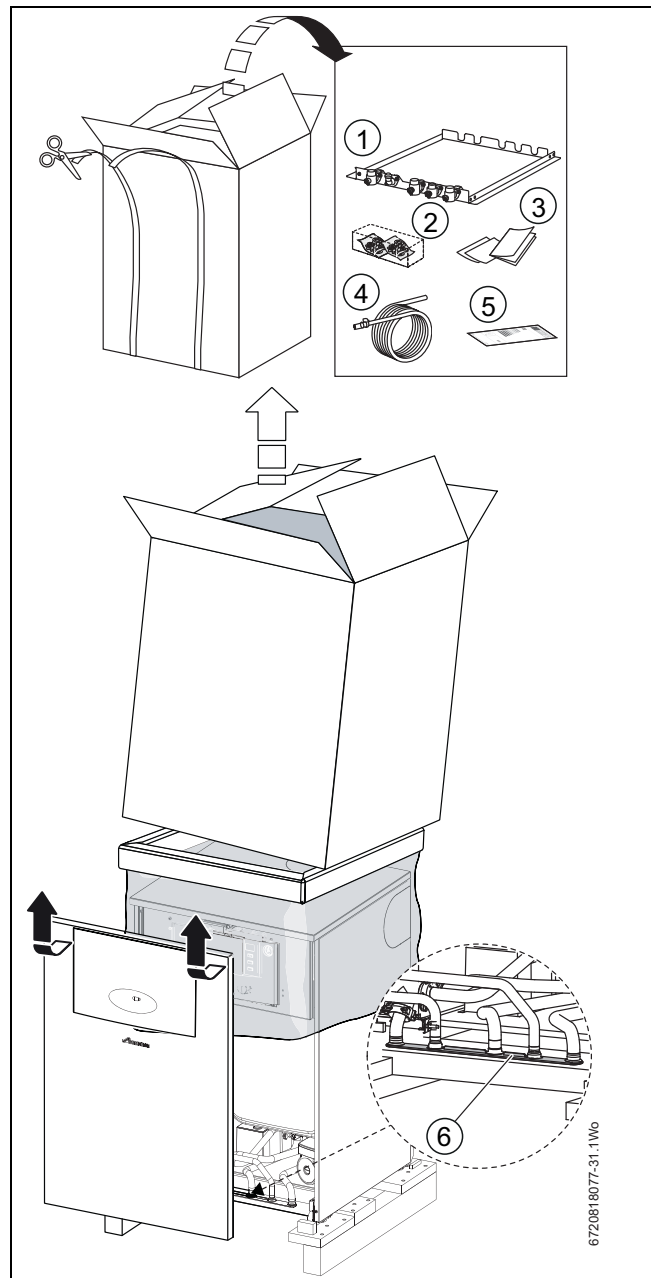

Fig. 18 Unpacking

- [1] Mounting frame
- [2] Installation pack
- [3] Literature pack
- [4] Condensate waste pipe and non-return valve
- [5] ErP energy label
- [6] Transit bung

4.2 Mounting frame fixing and flue opening



WARNING: Damage to property!
Damage caused by drilling into pipes, electrical cables, damp proof course or other hazards.
▶ Before drilling ensure that there are no obstructions.

Safety

All relevant safety precautions must be undertaken. Protective clothing, footwear, gloves and safety goggles must be worn as appropriate.



CAUTION: ISOLATE THE MAINS GAS SUPPLY BEFORE STARTING ANY WORK AND OBSERVE ALL RELEVANT SAFETY PRECAUTIONS.

Running pipes behind the boiler:

- The frame should sit against the wall (not the skirting board) with enough room for the pipe work.
- Do not cross a pipe over another.
- The area around a rear flue outlet must be avoided.

GAS AND WATER CONNECTIONS

- ▶ Ensure all pipe work is clean and each pipe is in the correct position as shown opposite.
- ▶ Push in each pipe in turn and tighten the fitting to secure.

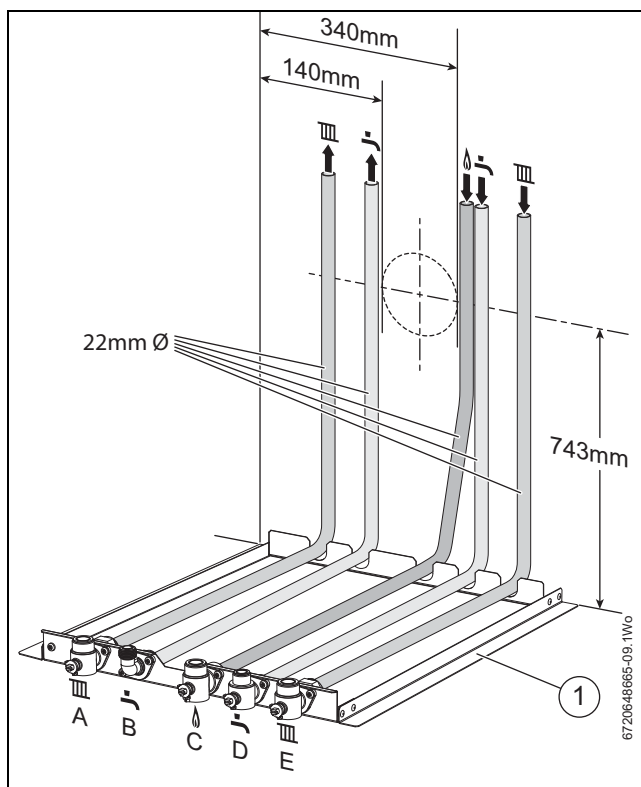

Fig. 19 Pipe locations

- [1] Mounting frame.
- [A] CH flow (22mm)
- [B] DHW flow (22mm)
- [C] Gas inlet (22mm)
- [D] Mains water inlet (22mm)
- [E] CH return (22mm)

Fixing the mounting frame

- ▶ Position the mounting frame [1] on the floor against the wall with manifold connections [2] facing away from the wall [4] ensuring there is enough space for the pipe work [5].
- ▶ Allow the minimum space from each side of the frame [1] for the boiler overhang [6] and minimum service clearance, as shown.
- ▶ Ensure the mounting frame is level and mark fixing points [3].
- ▶ Secure mounting frame [1] to the floor using appropriate fittings (not supplied).
- ▶ Clear any debris from the site.

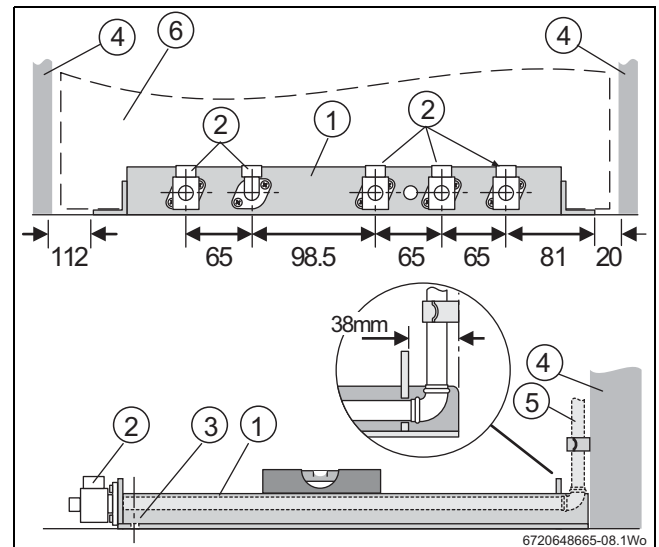

Fig. 20 Pipe positioning

- [1] Mounting frame.
- [2] Manifold connections.
- [3] Mounting frame fixing point.
- [4] Wall.
- [5] Gas and water pipe work (not supplied).
- [6] Boiler.

4.3 Flue opening location

- ▶ Follow the figure 21, page 22 to mark the centre of the flue [1 & 2] for rear opening, [2 & 3] for side opening or [1 & 4] for top opening. Measurements shown include the minimum service clearances.



All horizontal flue sections must rise away from the boiler by 52mm per metre to ensure that condensate flows back into the boiler for safe discharge via the condensate waste pipe.

- ▶ Cover the mounting frame manifold assembly [1], figure 20, page 21 to protect the manifold connections.
- ▶ Make an opening [X or Z] through the wall using a core drill or similar at a size relative to the wall thickness as shown below:

Wall thickness	Flue opening 60/100mmØ	Flue opening 80/125mmØ
150 - 240mm	127mmØ	152mmØ
240 - 330mm	127mmØ	152mmØ
330 - 420mm	127mmØ	162mmØ
420 - 500mm	140mmØ	162mmØ

Table 11

Where the flue terminal can only be fitted from inside the building, increase the opening to 150mmØ to allow the optional weather collar to fit through the opening for 60/100 flue.

- ▶ Clear any debris away from the site.

All dimensions in millimetres

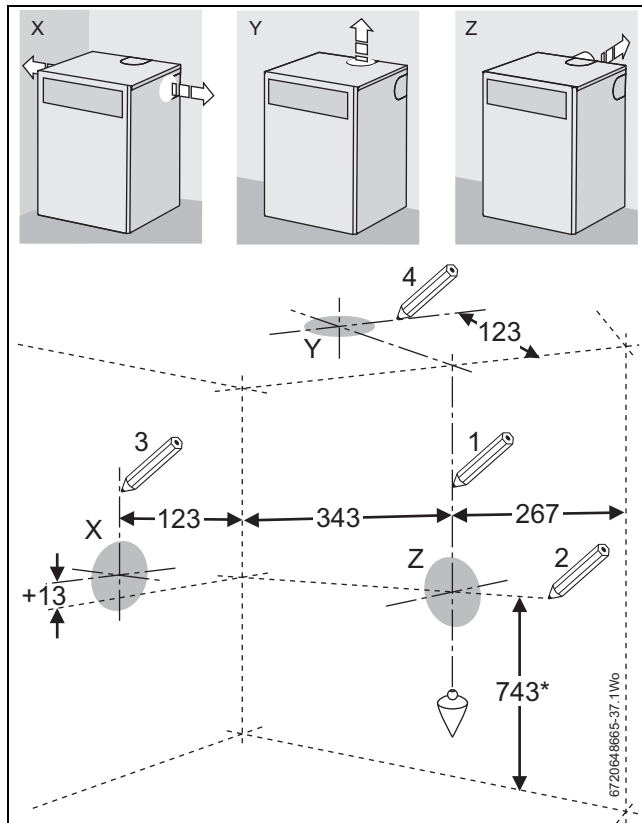

Fig. 21 Boiler flue outlet positions

[*] Increase this height by 52mm for every metre of horizontal flue length that the boiler is away from the flue opening

4.4 Flue measuring and cutting

NOTICE: Flue installation

- Refer to the Flue Kit Installation instructions provided with your flue kit to correctly install the flue with this floor standing boiler

NOTICE: FLUE LENGTH

- Do not exceed the maximum straight length for a horizontal or vertical flue or a 60mm plume management system (if used) as stated in the relevant Installation, Commissioning and Servicing Instructions manual or addendum.

Cutting the flue to an exact measurement is not normally required as the telescopic flue terminal can allow for some adjustment.

Maximum effective flue lengths HF 440/550 CDi ^{ERP}	L max. (mm)
60/100 horizontal	4 000
60/100 vertical	6 400
80/125 horizontal	13 000
80/125 vertical	15 000

Table 12 Maximum flue lengths

Flue Length guide

Flue length range (mm)	Cut	Number of extensions
140 ¹⁾ - 265	YES	None
310 - 530	NO	None
530 - 750	NO	None
750 - 1260	YES	1
1260 - 1480	NO	1
1480 - 2210	YES	2
2210 - 2430	NO	2
2430 - 3160	YES	3
3160 - 3380	NO	3
3380 - 4000	YES	4

Table 13 Flue extension guidance up to 4000mm

1) The flue is cut to a minimum of 130mm the flue connector adds the additional 10mm.

Access to combustion chamber for flue installation

- Grip the top outer sides of the front panel [1] pull forward to release the ball catches [2] and lift away from retaining lugs [3].
- Remove retaining screw [4] to swing control panel assembly [5] outwards to its full extent.
- Pull clip [6] outwards to release expansion vessel [7].
- Swing expansion vessel [7] outwards.

For easier access to the inner case, the expansion vessel can be unhooked (by removing the retaining screw on the hinge) lowered and moved to the side. Take care not to overstretch the flexible pipe connections.

- Remove the four screws [8] and remove the inner combustion case cover [9].
- Remove the two screws [10] at the front inside edge of the side panels [11] and lift the top panel [12] and pull forward to remove for easier access

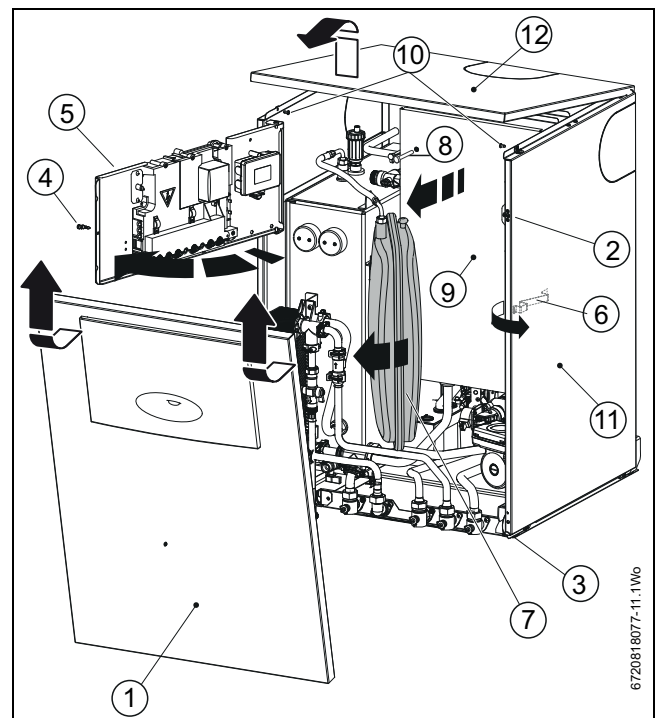

Fig. 22 Access for flue connection

4.5 Condensate, gas and water connections

4.5.1 Condensate connection

The condensate pump fills up and periodically discharges through the flexible condensate pipe [8] between 200mm to 4500mm from floor level. After this point the condensate flows, due to gravity, down the 21.5mm plastic pipe to the outlet.

- ▶ Fit the bayonet connector on the end of the condensate waste pipe to the condensate pump. Push down and rotate clockwise until the connector is locked.
- ▶ Route and secure the flexible condensate waste pipe [8] ensuring that the condensate waste pipe is clipped securely either side of any change of direction to prevent kinking or restriction.
- ▶ Cut off any excess pipe [8].
- ▶ Fit the condensate waste pipe [8] to adaptor [11] and secure with clip [10].
- ▶ Connect adaptor [11] to 21.5mm plastic pipe and terminate appropriately as described in section 3.4.

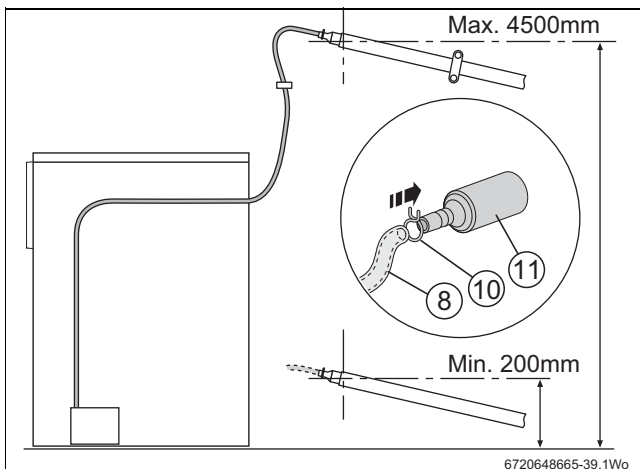

Fig. 23 Condensate connection

(See Pre-Installation section for condensate pipe work running from the adaptor [11] to the discharge outlet).

Never terminate or discharge into any open source, including; sink, basin, bath, shower, bidet, toilet etc.



- ▶ Any external condensate pipe work should be protected with weather resistant insulation to help prevent freezing.
- ▶ The flexible pipe supplied can only be used inside the property.



CAUTION: ISOLATE THE MAINS GAS AND WATER SUPPLY BEFORE STARTING ANY WORK AND OBSERVE ALL RELEVANT SAFETY PRECAUTIONS.

4.5.2 Gas and water connections

- ▶ Ensure that the transit bung [12] has been removed from the gas and water connections [A, B, C, D & E] on the boiler.



Surplus water may be present due to factory testing.

- ▶ Ensure the area is clear of debris and manoeuvre the boiler rear wheels onto the outer rails of the mounting frame [6].
- ▶ Take care when moving the boiler to position the front wheels onto the rails and align the gas/water connections and the flue.
- ▶ Secure boiler to mounting frame [6] with screw [13]
- ▶ Place the 4 larger valve sealing washers (shown shaded) onto valves [A, B, D & E].
- ▶ Place the bonded washer [C] on to the gas valve.

- ▶ Ensure all pipe work is clean.
- ▶ Tighten up the flat sealing connections to secure:
 - [A] - CH flow (22mm).
 - [B] - DHW flow (22mm).
 - [C] - Gas inlet (22mm) (bonded washer).
 - [D] - Mains water inlet (22mm).
 - [E] - CH return (22mm).

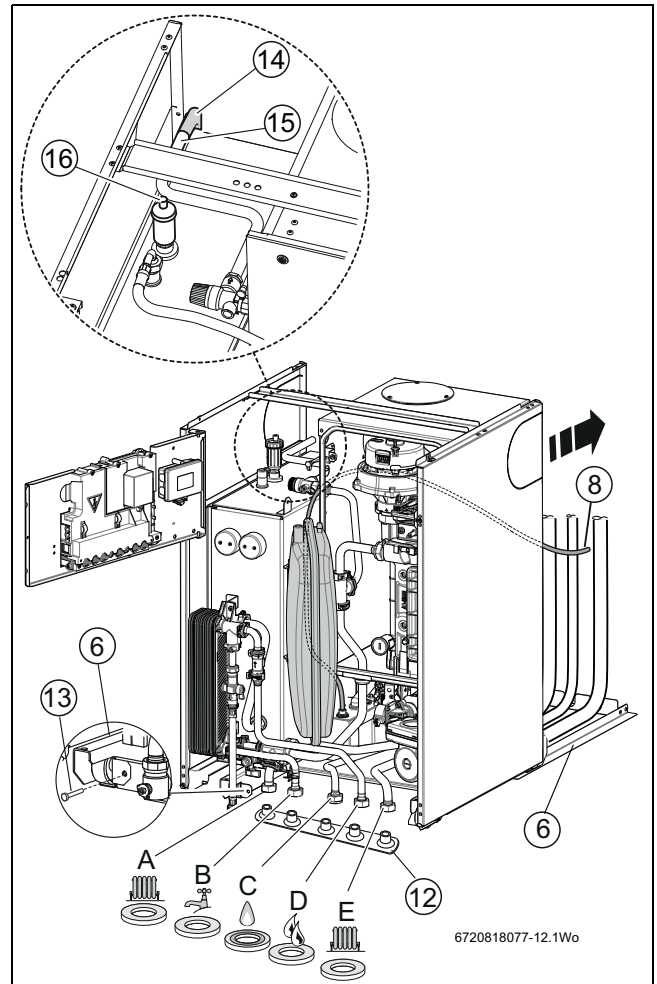

Fig. 24 Connections

4.6 Pressure relief valve outlet

Fitting the pressure relief valve drain pipe (→ figure 24):

- ▶ Connect a length of 15mm copper pipe [14] to the PRV drain pipe [15].
The PRV drain pipe [15] should be at least 15mm diameter and run down away from any electrical or other hazard.



NOTICE: The pressure relief valve is a safety device for the boiler and if activated may discharge boiling water or steam through the PRV drain pipe.

Auto air vent:

- ▶ Release the auto air vent cap [16].

4.7 Electrical

CAUTION: ISOLATE THE 230V ELECTRICITY SUPPLY

- ▶ Ensure that the electricity supply is safely isolated and secured to prevent inadvertent re-connection. Information on safe isolation can be found in the Health and Safety Executive guidance HSG85. Using test equipment approved to GS38 confirm that the electricity supply is disconnected

- i**
- ▶ The mains electrical supply to the boiler and system wiring centre must be common and through either a common fused double pole isolator or a fused three pin plug and unswitched socket.
 - ▶ The isolator shall be sited next to the boiler for new systems and where practicable, replacement boilers.
 - ▶ The isolator must have a contact separation of 3mm minimum between all poles.
 - ▶ Any system connected to the boiler must not have a separate electrical supply.
 - ▶ External fuse 3 Amps.
 - ▶ When stripping wires ensure copper strands do not fall into the control box.

List of wiring connections

L	Live incoming 230V supply
N	Neutral incoming supply
E	Earth incoming supply
LS	Live Supply to external controls (protected by F1 fuse)
NS	Neutral Supply to external controls
LR	Live Return (switch wire from external CH controls)
FS	Frost thermostat live supply
FR	Frost thermostat return (switch wire from frost stat)
F & A*	Outside temperature sensor (not polarity sensitive)
B & B*	EMS BUS connection used with some external controls (not polarity sensitive)

* These cables must be separated from mains cables by at least 100mm

Access to electrical connections

- ▶ Remove boiler casing to access control panel.
- ▶ Remove screw [1] and swing the control panel into the service position.

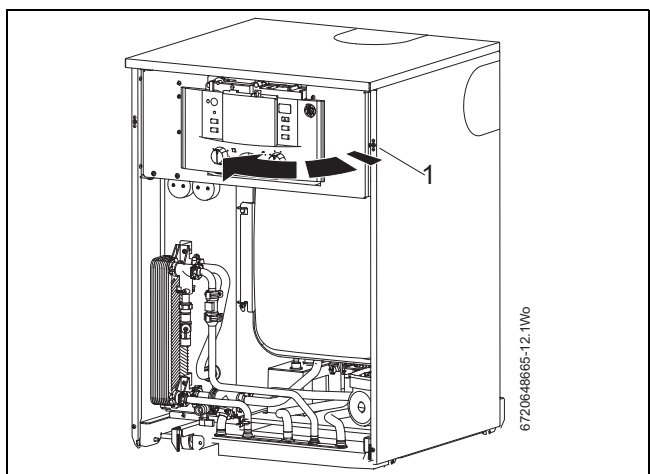

Fig. 25 Control box in service position

- ▶ Remove the three screws [2] in the control panel and remove the connections cover.
- ▶ Remove the installer module plastic cover [3].

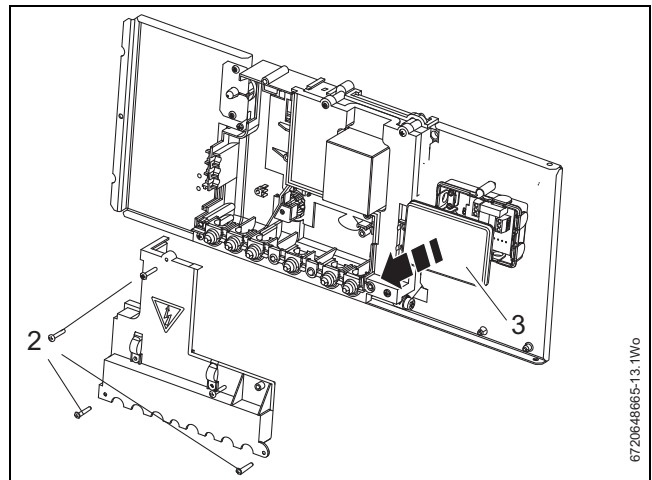

Fig. 26 Electrical connections access

Preparing cable clamps

- ▶ Unclip cable clamp [1].
- ▶ Cut off the tapered cable entry [2] to suit the cable diameter.
- ▶ Unscrew cable retaining screw [3].
- ▶ Prepare the cable as shown in the figure below.
- ▶ Run the cable [4] through the cable clamp [1] ensuring there is ample cable to reach the connectors.
- ▶ Tighten the cable retaining screw [3] to secure the cable, on the outer sheath, and replace clamp [1] into the control panel.

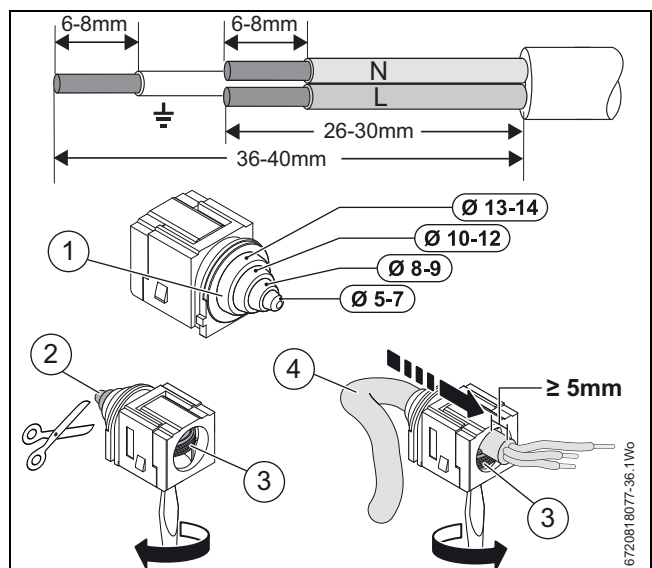

Fig. 27 Cable retainers

4.7.1 PCB Connections

1. Mains power 230 Volt connection ST10:
 - ▶ Separate wires from cable end and strip to 6mm
 - ▶ Connect LIVE wire to terminal L
 - ▶ Connect NEUTRAL wire to terminal N
 - ▶ Connect EARTH wire to the earth connector block next to ST10



Make the EARTH wire longer so that if the cable is snagged, the EARTH wire is the last to be pulled out.

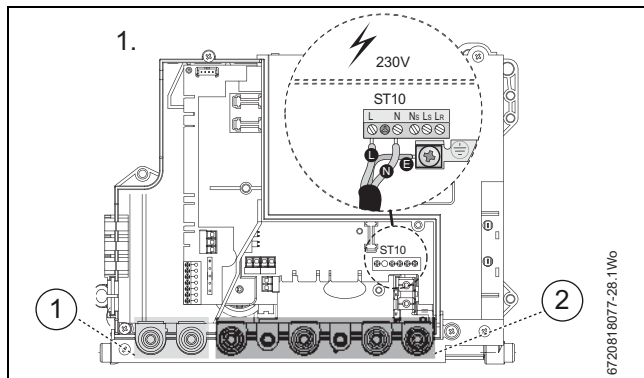

Fig. 28 Mains connections

- [1] These cable clamps are for EMS and sensor cables only
- [2] These cable clamps are for 230 volt connections only
2. EMS connection BB for controllers and outdoor sensor
 - ▶ EMS connection for intelligent controllers, e.g. Wave, Sense etc.
 - ▶ These connections are not polarity dependant
3. Optional frost thermostat connection ST6:
 - ▶ Connect frost thermostat supply wire to terminal F_S
 - ▶ Connect frost thermostat return wire to terminal F_R
4. 230V room thermostat and/or external timer ST10:
 - ▶ Remove link
 - ▶ Connect room thermostat LIVE supply to terminal L_S
 - ▶ Connect room thermostat LIVE return to terminal L_R
 - ▶ Connect room thermostat NEUTRAL to terminal N_S
 - ▶ Connect EARTH wire to the earth connector block next to ST10

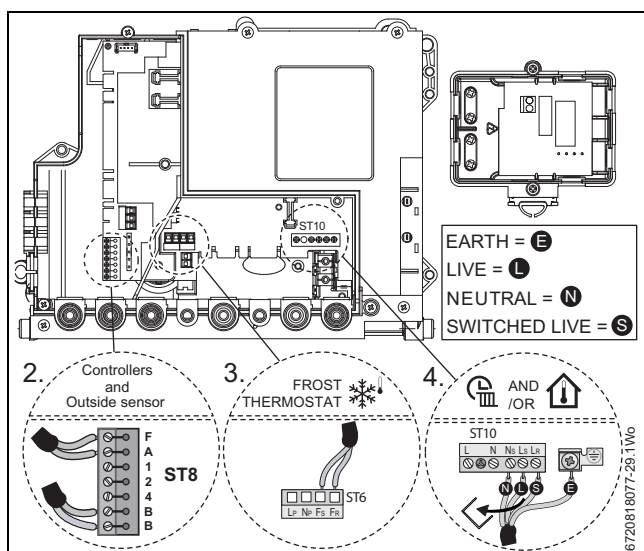

Fig. 29

5. Installer module for DHW timing
 - ▶ Connect external timer NEUTRAL to top terminal
 - ▶ Connect external timer DHW ON to bottom terminal
 - ▶ Refit all panels

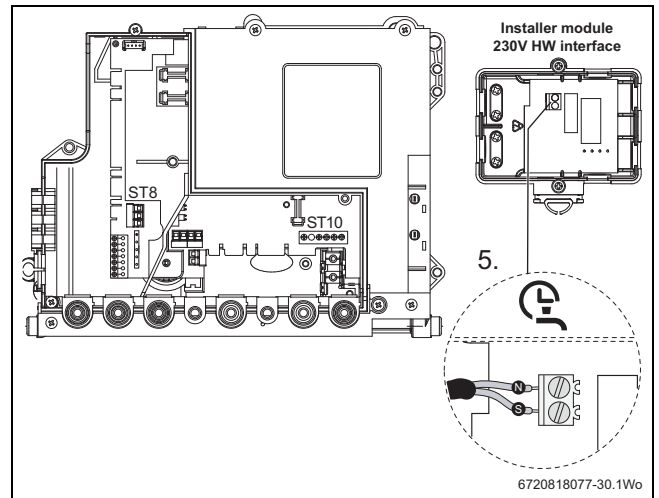

Fig. 30 External timer for hot water

Refer to manufacturers instructions when connecting external parts to the boiler.

Worcester, Bosch Group cannot be held responsible for wiring errors.

5 COMMISSIONING

5.1 Pre-commissioning checks

CAUTION: ISOLATE THE MAINS ELECTRICITY SUPPLY

- ▶ Ensure that the electricity supply is safely isolated and secured to prevent inadvertent re-connection. Information on safe isolation can be found in the Health and Safety Executive guidance HSG85. Using test equipment approved to GS38 confirm that the electricity supply is disconnected

- ▶ Check that the service and water pipes [1] are connected to the correct valve on the manifold;
 - A - CH flow (22mm)
 - B - DHW flow (22mm)
 - C - Gas inlet (22mm)
 - D - Mains water inlet (22mm)
 - E - CH return (22mm)
- ▶ Check the gas type specified on the identification plate matches that of the gas supply.
- ▶ Turn on the main gas supply [2], check the gas pipe work, connections and rectify any leaks.
- ▶ Check the flue [3] is correctly fitted and the connections are secure.
- ▶ Check the condensate pipe work [4] is correctly fitted and connected.

NOTICE: If the boiler is not to be commissioned immediately then, after successfully completing all of the checks and any rectification work:

- ▶ Close the gas valve
- ▶ Close the water shut off valve
- ▶ Isolate the gas supply
- ▶ Isolate the electricity supply
- ▶ Label appropriately

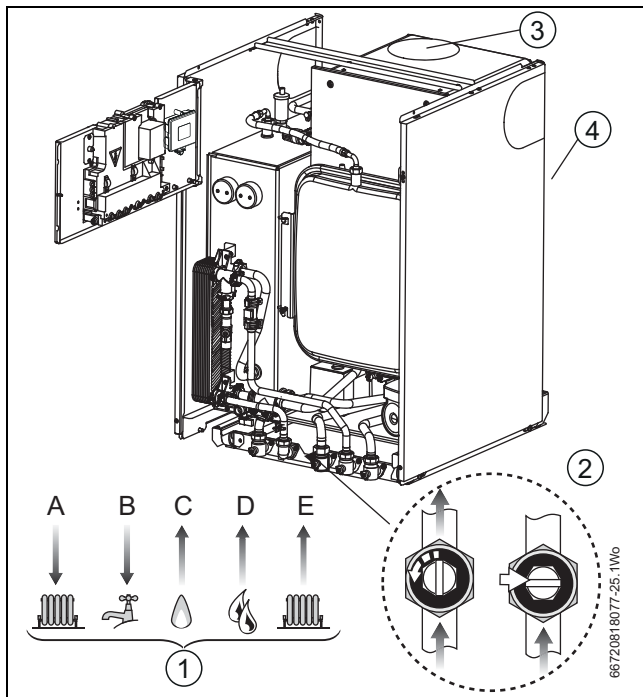

Fig. 31 Pre-commissioning checks

5.2 Filling the system

- ▶ Pull the upper edges of the front panel towards you and lift off the bottom lugs.
- ▶ Turn on the water main and open the system valves (align slot vertically).
- ▶ Open all radiator valves.
- ▶ Unscrew the tank drain cap [1] from the Tank drain valve [7].
- ▶ Connect the integral filling loop from the Flow valve [5] using the hose [4] to the Tank drain valve [7].
- ▶ Open the flow valve [5] and tank drain valve [7].
- ▶ Fill the system to a pressure up to 1.5 bar.
- ▶ Close the flow valve.
- ▶ Close the tank drain valve.
- ▶ Disconnect the integral filling loop.
- ▶ Refit tank drain cap.
- ▶ The Automatic Air Vent will release any air trapped in the boiler.
- ▶ Vent all radiators, retighten the vent when completed.
- ▶ Check the system and correct any leaks.

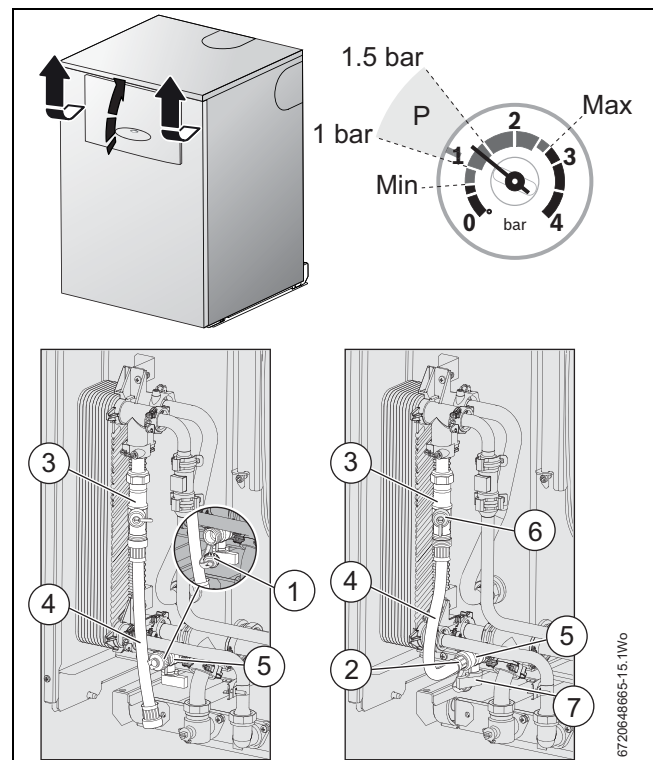

Fig. 32 Internal filling loop

The boiler integral expansion vessel is pre-charged to 0.75bar (equal to a static head of 7.5m (22ft)). A Schraeder type valve is fitted to the expansion vessel to allow for pressure adjustment if required. If an additional expansion vessel is fitted to the central heating return, adjust this to the same pressure as the appliance internal expansion vessel, refer to the instructions with the additional expansion vessel for pressurising.

5.3 Water treatment

NOTICE: Debris from the system can damage the boiler and reduce efficiency. Failure to comply with the guidelines for the use of water treatment with the appliance will invalidate the appliance warranty.

NOTICE: SOFTENED WATER
▶ ARTIFICIALLY SOFTENED WATER MUST NOT BE USED TO FILL THE CENTRAL HEATING SYSTEM.

ENSURE THAT THE SYSTEM HAS BEEN CLEANED AS ON PAGE 11 OF THESE INSTRUCTIONS.

INHIBITOR (Central Heating):

▶ Check drain cocks are closed and all radiator valves are open before adding a suitable inhibitor compatible with aluminium (or combined inhibitor/anti-freeze if the system is exposed to freezing conditions) to the heating system water in accordance with the manufacturers instructions.

i The pH value of the system water must be less than 8 or the appliance warranty will be invalidated.

- ▶ Fill the system to between 1 and 1.5 bar via the supplied internal WRAS approved filling loop figure 32 on page 26.
- ▶ Vent the boiler and all radiators; retighten vents when complete.
- ▶ Record the date when the inhibitor was added to the system on the guarantee card.

NOTICE:

- ▶ The concentration of inhibitor in the system should be checked every 12 months or sooner if system content is lost.
- ▶ The addition of sealing agents to the system water is not recommended as this can cause problems with deposits left in the heat exchanger.
- ▶ In cases where all attempts to find a micro leak have failed, Worcester, Bosch Group supports the use of Fernox F4 leak sealer.

5.4 Starting the appliance

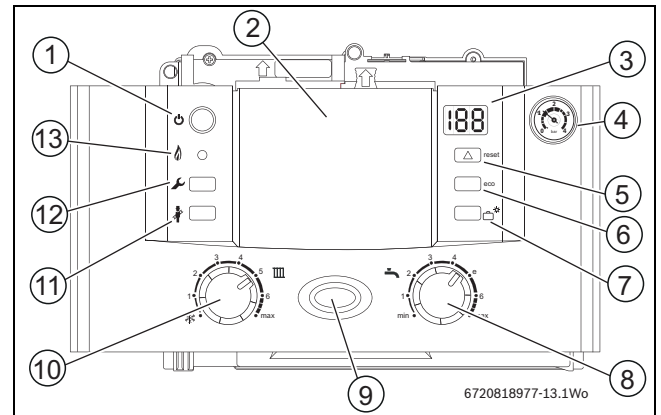

Fig. 33 Fascia guide

- [1] Master switch for ON/OFF
- [2] Position for optional programmer
- [3] Display
- [4] System pressure gauge
- [5] Fault reset button (red)
- [6] ECO button (domestic hot water pre-heat ON/OFF) (green)
- [7] Not used
- [8] Domestic hot water temperature control
- [9] 230V mains ON/OFF indicator + blue fault diagnostic light
- [10] Central heating temperature control
- [11] Service engineer button (orange)
- [12] Service menu button (orange)
- [13] Burner on indicator light (green)

5.4.1 Switching the appliance on/off:

NOTICE: Never run the appliance when the appliance or system is empty or unpressurised.

- ▶ Turn on mains power supply.

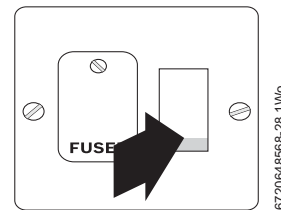

Fig. 34 3 Amp fused double pole isolator

- ▶ Turn on any external controls.
- ▶ Set the TRV controls to maximum.
- ▶ Set the clock/programmer to continuously ON and the room thermostat to maximum temperature.
- ▶ Press button [1] and the power on indicator [9] illuminates blue.

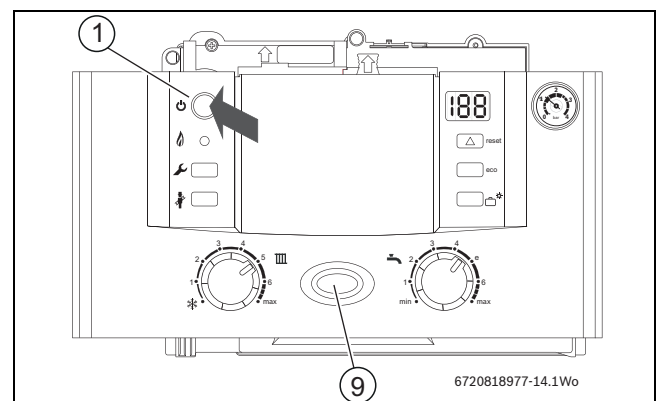

Fig. 35 Turning on the appliance

- ▶ Turn the temperature control [10] to maximum. The burner on indicator [13] illuminates green when the burner has lit.



The boiler runs for 15 minutes at minimum heating output to fill the condensate trap. This occurs every time the mains supply has been interrupted.

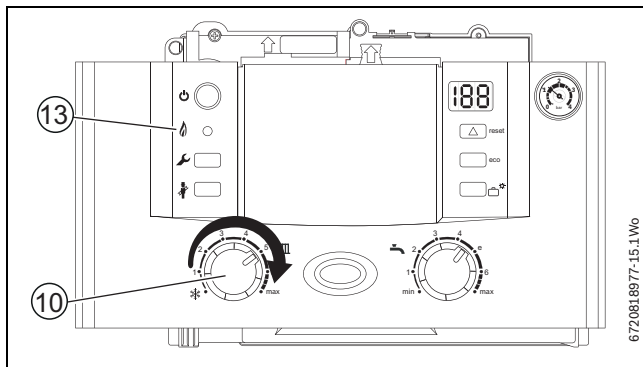

Fig. 36 Operating the boiler

- ▶ If the boiler fails to light, the blue power indicator [9] and reset button [5] will flash alternately.
- ▶ To reset the boiler, press and hold the reset button [5] for 2 seconds.

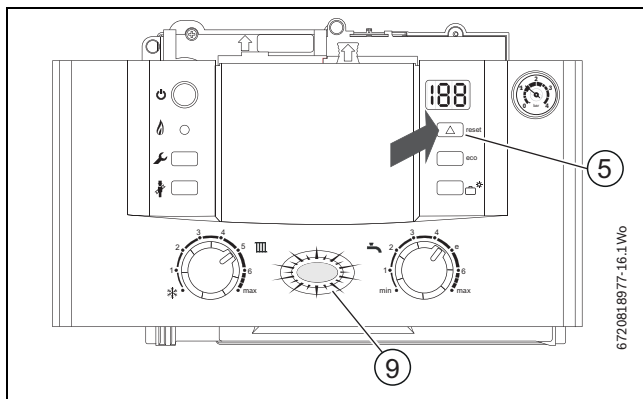

Fig. 37 Boiler reset



CAUTION: DO NOT PRESS THE POWER INDICATOR [9] TO RESET THE BOILER.

5.4.2 Initialization

The appliance performs a self test at initial switch on that takes approximately 10 seconds.

During the test, the display shows **188** for the first two seconds.

The Service engineer and the Service menu buttons light up orange and the Reset button lights up red.

Afterwards the display shows the Central heating temperature.

On successful completion of the test sequence the appliance is ready for operation.

5.4.3 Display messages

Special messages	Description
	Key acknowledgement after pressing one button (except reset button)
	Key acknowledgement after pressing two buttons simultaneously

Table 14 Special display messages

Special messages	Description
	Key acknowledgement after pressing button longer than 3 seconds (save function)
	The display shows alternatively the CH flow temperature and . The appliance works continuously at the minimum power (see Engineer's Service manual - function 2.F).
	The display shows alternatively the CH flow temperature and . The appliance works continuously at the maximum power (see Engineer's Service manual - function 2.F).
	Appliance is in Air purge mode, (see Engineer's Service manual - function 2.C.
	The display shows alternatively the CH flow temperature and . The Syphon-fill programme is active. (see Engineer's Service manual - function 4.F
	The display shows alternatively the CH flow temperature and reminding that the next service is due. The burner service interval of 2324 hours has run out. (see Engineer's Service manual - function 5.F.
	The display shows alternatively the CH flow temperature and . The pump is blocked. See error E9.
	The display shows alternatively the CH flow temperature and . The gradient limitation is active. The primary temperature is rising too fast and the burner has switched off for 2 minutes. See error E9.
	When the control is in internal heat bank demand the display will alternate between the primary temperature and the tank demand symbol.

Table 14 Special display messages

5.5 Checking gas inlet pressure

5.5.1 Measuring the inlet pressure

The inlet pressure to the appliance must be checked using the following procedure:

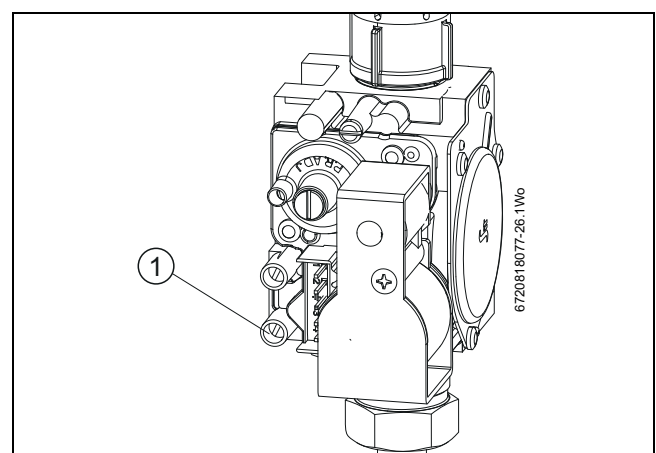

Fig. 38 Inlet test point

- ▶ Close the gas isolation valve.
- ▶ Slacken the screw in the inlet pressure test point [1] and connect a manometer.
- ▶ Open the gas isolation valve.

- ▶ Measure the pressure with the boiler running at maximum.
 - Refer to figure 33 for control panel guide
 - Press Service engineer button [11] for more than ten seconds and set Central Heating temperature to maximum.
 - The Service engineer button [11] will illuminate continually and the blue power indicator will pulse five times.
- ▶ Check the gas supply working pressure at the gas valve conforms to values shown in figure 39 or figure 40.



Ensure inlet pressure is satisfactory with all other gas appliances working.

Gas pressure within the system



The boiler must be running at maximum output rate when performing the gas rate check.

Refer to the figures below for natural gas or L.P.G gas pressures.

The pressure at the boiler must not be less than the pressure read at the meter minus:

- 1 mbar for Natural Gas
- 2.5 mbar for L.P.G.

The pressure drop from the meter to the gas valve must not be more than:

- 2.5 mbar for Natural Gas
- 4 mbar for L.P.G.

If the pressure drops are greater than shown below, then this would indicate a problem with the pipe work or connections within the system.

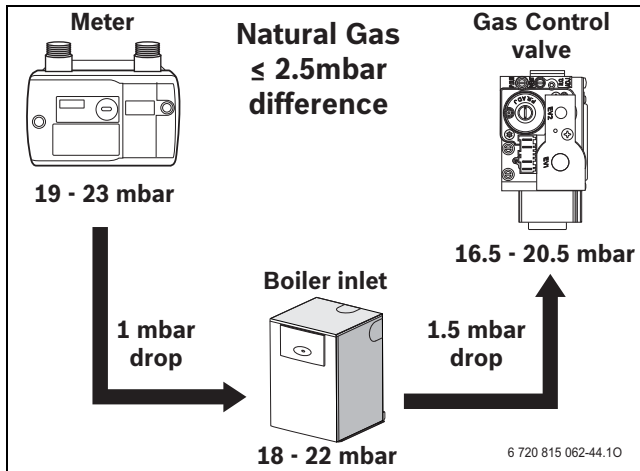

Fig. 39 Natural gas pressures

[≤] Equal to or less than

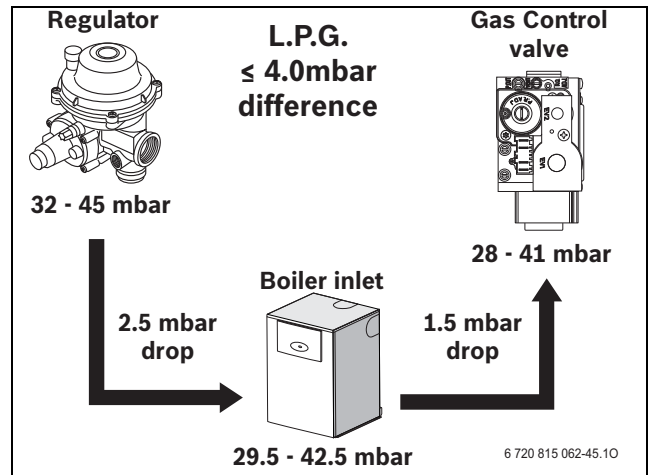

Fig. 40 L.P.G. pressures

NOTICE:
Do not continue commissioning until the correct gas pressure is achieved.

- ▶ If pressure is satisfactory press the Service engineer button [11] again and the boiler will return to normal operation.
- ▶ If left in the Service mode the control will return to normal operation after 15 minutes.
- ▶ Re-seal the screw in the gas inlet pressure test point.

5.5.2 Checking the gas rate

- ▶ The gas rate should be measured at the gas meter after 10 minutes operation at maximum, refer to technical data in section 2.2.
- ▶ Where a gas meter is not available (e.g. L.P.G.) the CO/CO₂ must be checked to the units shown in the setting the air/gas ratio, refer to section 6.8.
- ▶ If pressure and gas rate are satisfactory press the Service engineer button [11] again and the boiler will return to normal operation.
 - If left in the service mode the control will return to normal operation after 15 minutes.
- ▶ Close the gas isolation valve.
- ▶ Remove the manometer.
- ▶ Re-seal the screw in the gas inlet pressure test point.
- ▶ Open the gas isolation valve.
- ▶ Ensure that there are no gas leaks.
- ▶ Replace the outer case.

5.6 CO and combustion check

The following combustion and flue integrity checks are mandatory and these values must be recorded on the Benchmark check list, at the back of this manual.

Once the gas rate and pressure have been confirmed as acceptable then the CO and combustion checks can be undertaken.

The flow chart is given for guidance, the details of the checks are given in the following sections:

- Checking flue integrity, refer to section 6.5, page 33
- Flue gas analysis, refer to section 6.6, page 33

NOTICE: Before CO and combustion checks:

- ▶ Refer to section 5.5.1 and 5.5.2 to verify gas type, gas inlet pressure, and gas rate. Visually check the integrity of the whole flue system and confirm that all the components are correctly assembled, fixed and supported.
- ▶ The flue gas analyser must be the correct type as specified in BS 7967. Before use the analyser must have been calibrated as specified by the manufacturer. The installer must be competent in the use of the analyser. Check and zero the analyser in fresh air as specified by the manufacturer.
- ▶ The air/gas ratio valve is factory set and must not be adjusted during commissioning unless this action is recommended following contact with the Worcester, Bosch Group help line 0330 123 3366.

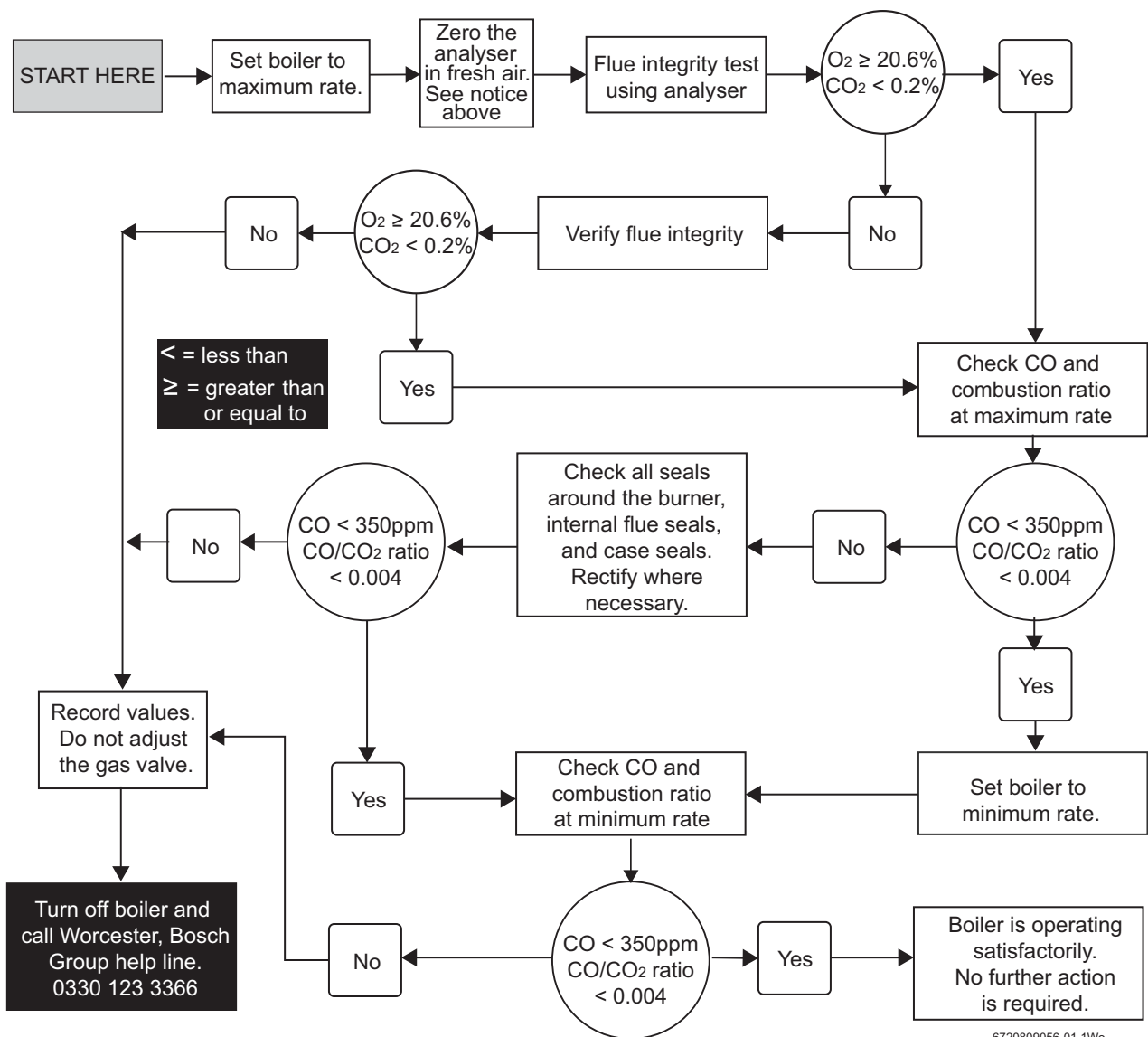

6720809056-01.1Wo

Fig. 41 Commissioning checks

5.7 Finishing commissioning



At the time of commissioning, complete all relevant sections of the Benchmark Checklist located on the inside back pages of this document.

1. Engage top panel [2] onto rear retainers [3] and lower front of panel into position.
 - ▶ Secure the top panel with the two screws [4].
2. Swing the control panel assembly [5] into the boiler.
 - ▶ Secure with the screw [6].
3. Locate the bottom corners of the front panel [1] into retaining lugs [7].
 - ▶ Push the top of front panel [1] in to engage with the two ball catches [8].

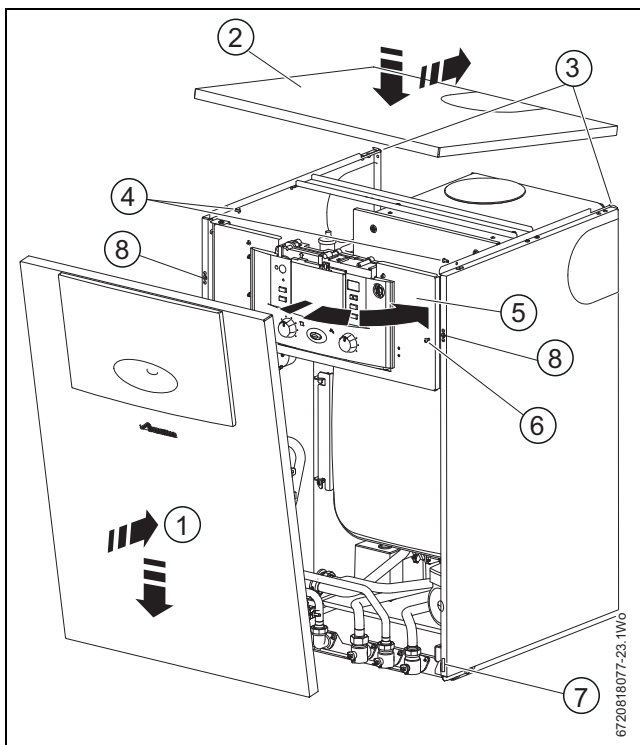

Fig. 42 Finishing commissioning

HANDOVER:

- ▶ Complete the Benchmark log book at the rear of the manual.
- ▶ Set up the controls and show the user how to operate all the controls shown in the User Guide.
- ▶ Instruct the user how to repressurise the system.
- ▶ If the appliance is unused and exposed to freezing conditions, advise the user of the precautions necessary to prevent damage to the boiler, system and building.
In the event of the appliance being inoperative, isolate the boiler and drain the system and boiler.

6 SERVICING AND SPARES

6.1 Inspection and service



CAUTION: ISOLATE THE GAS SUPPLY

- ▶ Ensure that the gas supply is safely Isolated and secured to prevent inadvertent re-connection.
Follow all relevant safety precautions



CAUTION: ISOLATE THE 230V ELECTRICITY SUPPLY

- ▶ Ensure that the electricity supply is safely Isolated and secured to prevent inadvertent re-connection. Information on safe isolation can be found in the Health and Safety Executive guidance HSG85. Using test equipment approved to GS38 confirm that the electricity supply is disconnected



NOTICE: COMPONENTS.

- ▶ After replacement of any components always check for gas tightness where relevant and carry out functional checks as described in Commissioning. Damaged O-rings or gaskets must be replaced.



NOTICE: SERVICE WORK

- ▶ SERVICE WORK MUST **NOT** BE ATTEMPTED IF A CO/CO₂ ANALYSER IS **NOT** AVAILABLE.
- ▶ Service work must be carried out by a competent registered gas engineer, such as British Gas or Gas Safe registered engineer!



After servicing, complete the relevant Service Interval Record section of the Benchmark Checklist located on the inside back pages of this document.

- To ensure the continued efficient operation of the appliance it must be checked at regular intervals.
- The frequency of servicing will depend upon the particular installation conditions and usage however, an annual service is recommended.
- The extent of the service required by the appliance is determined by the operating condition of the appliance when tested by fully qualified engineers.

Inspection

1. Check that the terminal and the terminal guard, if fitted, are clear from any obstructions and undamaged.
2. If the appliance is in a compartment or cupboard check that the specified service space around the appliance is clear.
3. Check all the joints and connections in the system and remake any that show signs of leakage. Refill and re-pressurise if applicable as described in Commissioning.
4. Operate the appliance and take note of any irregularities. Call up the last fault stored by the Bosch Heatronic control, Service Function '6A'.
Refer to Fault Finding on page 43 for rectification procedures.

Max pressure

- ▶ When the heating system water is at maximum temperature, 2.5 bar must not be exceeded. If this pressure is exceeded then an additional expansion vessel must be fitted into the system return as close as possible to the appliance.
- ▶ If the system does not retain the pressure, the pressure relief valve (PRV) and the heating system should be checked for leaks.

6.2 Service function

Setting boiler to maximum:

- i** ▶ When running in the Service engineer mode, the boiler will operate both the Central Heating and DHW circuits.
- ▶ It will be necessary to run water through the DHW circuit to ensure that the boiler will not cycle during Service mode.

- ▶ Press and HOLD the Service engineer button [11] for 10 seconds and set Central Heating temperature to maximum. The Service engineer button will illuminate continually. The boiler will stay in this mode for 15 minutes unless the Service engineer button is pressed again.

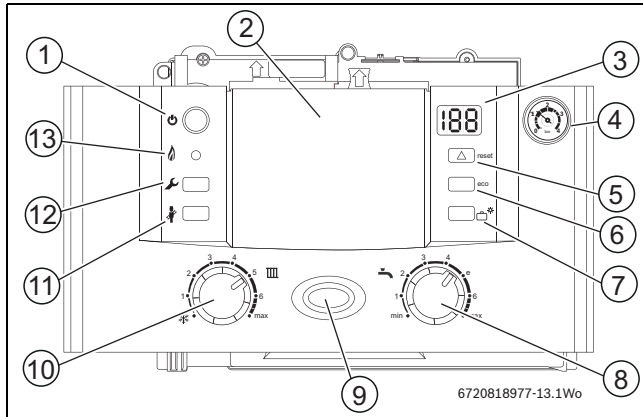

Fig. 43 Fascia guide

- [1] Master switch for ON/OFF
- [2] Position for optional programmer
- [3] Display
- [4] System pressure gauge
- [5] Fault reset button
- [6] ECO button (domestic hot water pre-heat ON/OFF)
- [7] Not used
- [8] Domestic hot water temperature control
- [9] Mains ON/OFF indicator + blue fault diagnostic light
- [10] Central heating temperature control
- [11] Service engineer button
- [12] Service menu button
- [13] Burner on indicator light (green)

6.3 Service inspection

- ▶ Grip the outer sides of the front panel [1] pull away from the ball catches [2] and lift off the lugs [3]
- ▶ Remove retaining screw [4] to swing control panel assembly [5] outwards to its full extent.
- ▶ Pull clip [6] outwards to release expansion vessel [7].
- ▶ Swing expansion vessel [7] outwards.

i For easier access to the inner case, the expansion vessel can be unhooked (by removing the retaining screw on the hinge) lowered and moved to the side. Take care not to overstretch the flexible pipe connections.

- ▶ Release four screws [8] to remove the inner case cover [9].

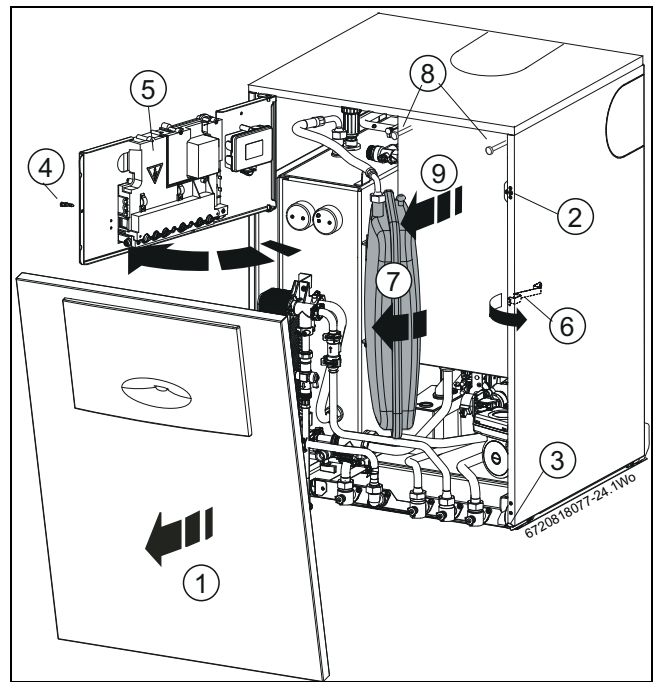

Fig. 44 Access for servicing

6.4 Fan pressure test

- ▶ Remove the test point cover
- ▶ Connect a manometer to the fan pressure test point, [1].
- ▶ Set the boiler to maximum output.
- ▶ After measurement replace test point cover.

Pressure readings will be negative, refer to figure 46.

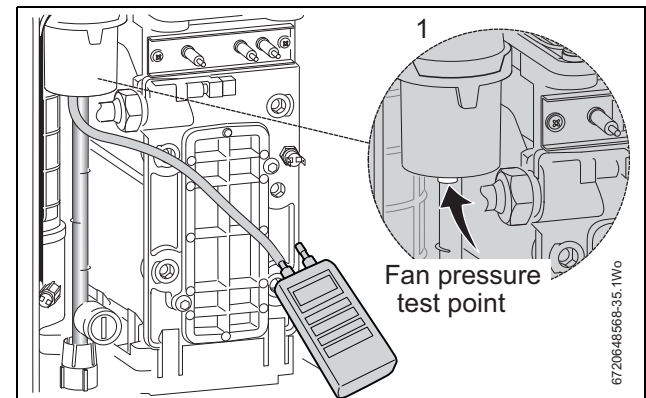

Fig. 45 Fan control pressure test

NOTICE: Fan pressure test

- ▶ The boiler must be run at maximum output for the fan pressure test.

With the boiler running at maximum output, measure the fan pressure:

- ▶ The pressure will read negative, refer to the chart in figure 46 below.

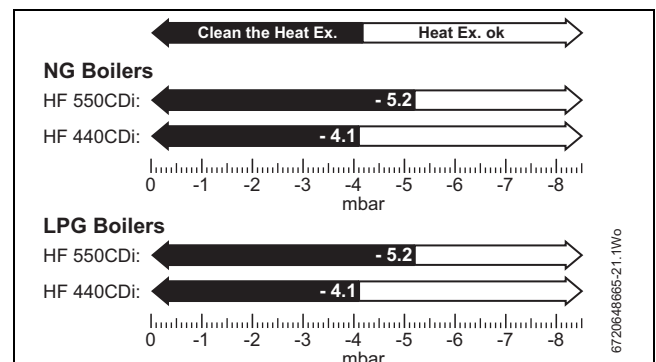

Fig. 46 Fan control pressure readings

- ▶ If the manometer reading is in the white area of the chart the heat exchanger/exhaust path/condensate trap does not require attention.
 - ▶ If the manometer reading is in the black area of the chart then carry out the following checks:
 - Check that the condensate trap is not blocked.
 - Check the exhaust paths for restrictions.
 - Clean the heat exchanger with a suitable cleaning tool, refer to section 6.7.4 - Cleaning the heat exchanger.
 - ▶ Re-check the fan pressure readings.
- If the boiler, after completing the above checks, fails the fan pressure test then contact Worcester, Bosch Group for advice.
- ▶ After the measurements are taken switch the boiler off.
 - ▶ Disconnect the manometer and replace the test point cover.

6.5 Checking the flue integrity



The appliance combustion cover must be fitted whilst this test is being performed.



Refit the test point caps after the test has been performed.

The integrity of the flue system and performance of the appliance can be checked via the sample points at the top left hand side of the combustion chamber, refer to figure 47.

- ▶ With the combustion cover fitted and the appliance running at maximum output for at least 10 minutes, remove the cap from the air inlet sample point [2]
- ▶ Attach the analyser probe to the sample point
- ▶ Allow the readings to stabilise and check that:
 - O₂ is equal to or greater than 20.6%
 - CO₂ is less than 0.2%
- ▶ If the readings are outside these limits, then this indicates that there could be a problem with the flue system or combustion circuit.

6.6 Flue gas analysis



Ensure that the gas inlet pressure is correct before continuing, refer to section 5.5.1

Combustion test:

- ▶ Remove cap on the flue gas sample point [1], as shown in figure 47 and connect a flue gas combustion analyser. Replace the cap after use.
- ▶ Press the Service engineer button for more than 10 seconds
- ▶ Turn the temperature control to maximum and the boiler will go to maximum output
- ▶ Run the boiler at maximum output for at least 10 minutes.
- ▶ After 10 minutes check the CO/CO₂ readings against those in table 15 - CO/CO₂ settings, on page 37
- ▶ Turn the temperature control down to minimum and allow the boiler to stabilise for ten minutes
- ▶ Check the CO/CO reading for minimum output against those in table 15 - CO/CO₂ settings, on page 37

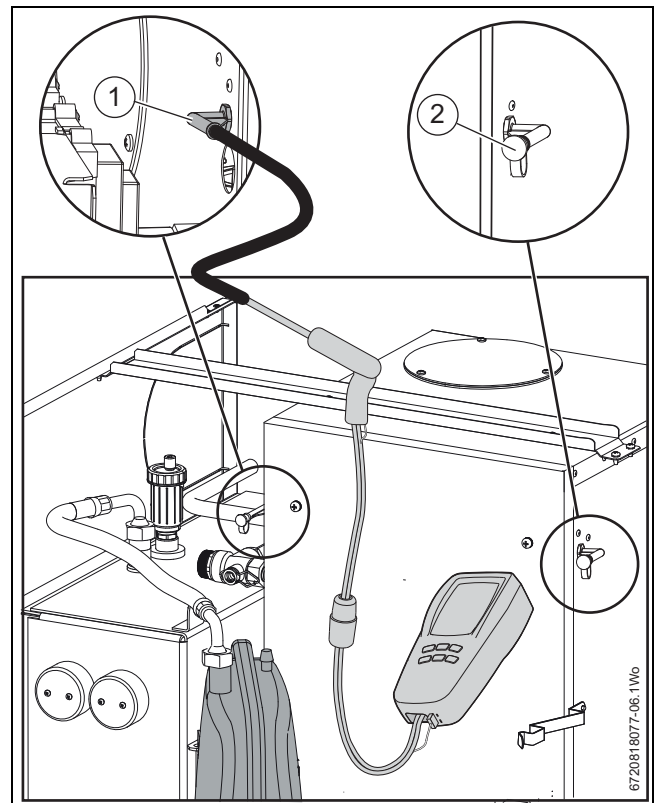

Fig. 47 Flue integrity test

- [1] Flue gas sample point
- [2] Combustion air sample point

If the boiler fails the combustion test, check the following possible causes:

1. Refer to section 5.5.1 and check the gas inlet pressure
2. Confirm the correct fan pressure.
3. Air intake for restrictions.
4. Check the diaphragm in the fan for damage, replace if damaged.
5. Check the diaphragm for correct operation, the diaphragm opens towards the fan.
6. Cleanliness of the heat cell, plus blockages in the condensate disposal.

6.7 Heat exchanger

6.7.1 To clean the burner



WARNING: Burner

- ▶ Do not remove the burner unless a new burner head gasket is available for re-assembly.

- ▶ Check that the boiler is completely isolated from the gas supply.
 - ▶ Disconnect the mixing chamber from the fan.
 - ▶ Remove the connector and earth wire from the fan.
 - ▶ Remove the clips [1], castellated nuts [2a] and springs [2b] from the studs [2].
 - ▶ Remove the rear nut [4a] from the rear stud [4].
 - ▶ Remove the burner cover plate [5] and fan [7] from the top of the heat exchanger.
 - ▶ Remove the burner [6] and clean the components.
- Do not use a wire brush.**

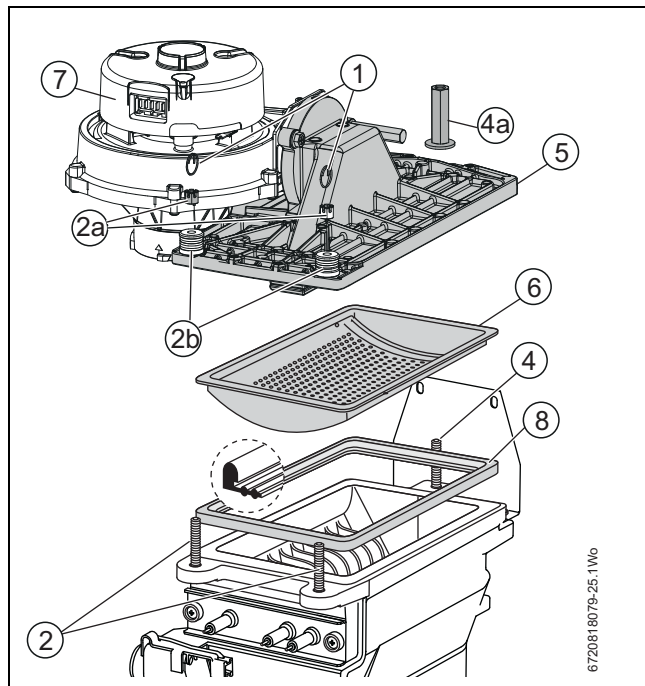

Fig. 48 Burner removal

6.7.2 To check the flap valve in the fan intake

- ▶ Refer to section 6.9.3 on page 38 for access to the fan intake.
- ▶ Carefully withdraw the flap valve from fan intake tube and check for soiling and splits, clean or replace as required.
- ▶ Take care when refitting the flap valve, the flaps must open upwards into the fan intake tube.
- ▶ After re-assembly check CO/CO₂ levels as described in the section "Setting the air/gas ratio" on page 36.

6.7.3 To clean the condensate trap

- ▶ Remove the condensate pump refer to section 6.9.4
- ▶ Remove the screw retaining the trap
- ▶ Rotate the condensate trap anti-clockwise by 90°
- ▶ Pull the trap down from the sump connection
- ▶ Angle the trap backwards and remove from the boiler
- ▶ Release the cap and dispose of the debris into a suitable container
- ▶ Replace the cap
- ▶ Before replacing the trap, fill with at least 250ml of clean water
- ▶ Replacing the trap is the reverse of the removal procedure
- ▶ Reconnect the condensate pump and the pipe from the trap
- ▶ Reconnect the condensate disposal pipe

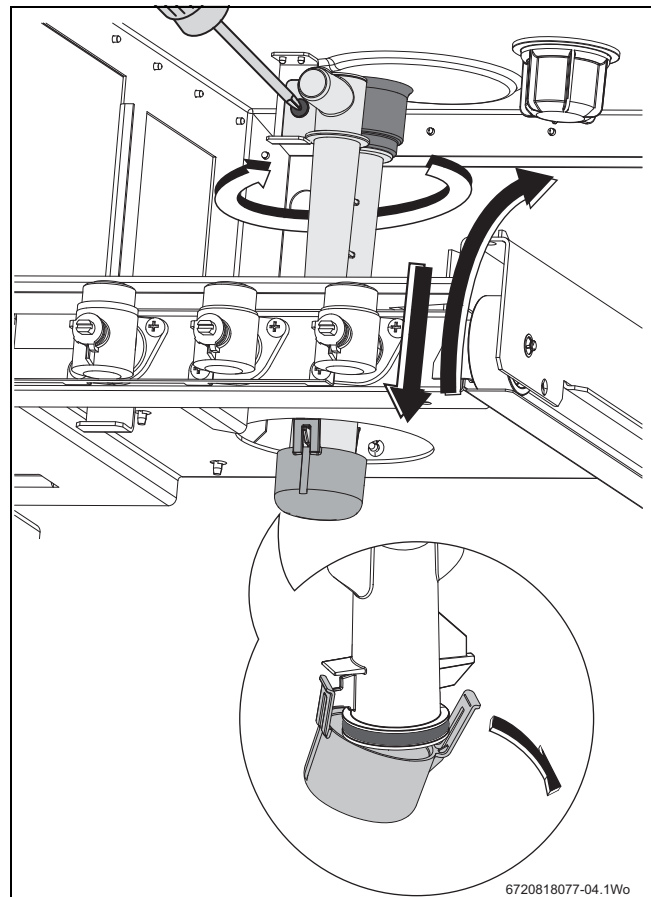

Fig. 49 Condensate trap access

6.7.4 Cleaning the heat exchanger



WARNING: Cleaning access cover

- ▶ Do not remove the cover unless a new gasket is available for re-assembly.



NOTICE: After completing the appliance service the CO/CO₂ must be checked and set to the limits in the section "AIR/GAS RATIO".



An accessory kit is available (No. 840) specifically designed for cleaning the heat exchanger containing: new seal, cleaning brush and knife/rasp. If required order 7 719 001 996.

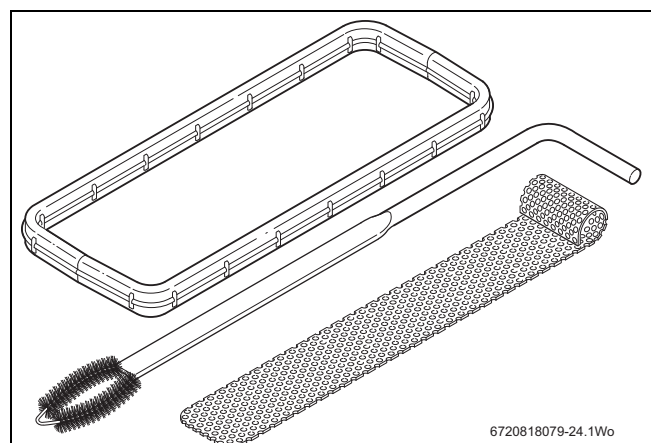

Fig. 50 Cleaning kit

If the Heat Exchanger requires cleaning:

- ▶ Remove the condensate trap.
- ▶ Remove the cleaning access cover [1] and seal [2].

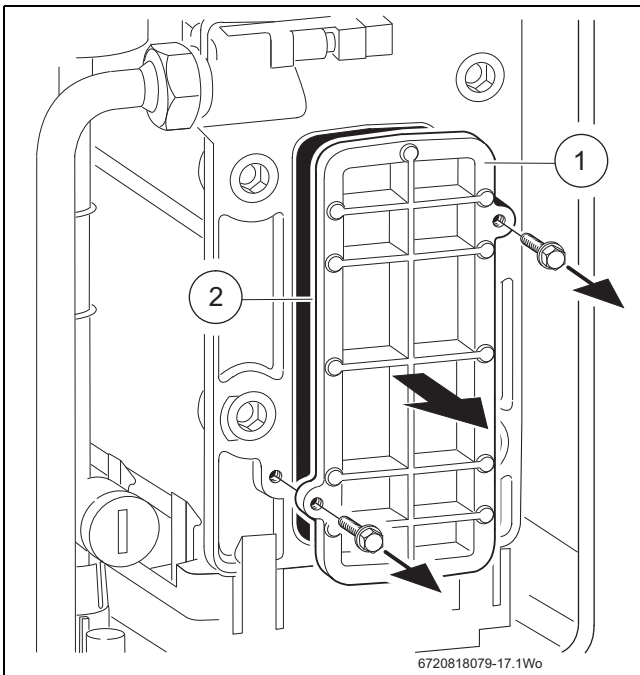

Fig. 51 Remove cover

- ▶ Press at the bottom to remove the metal plate [3], if fitted.

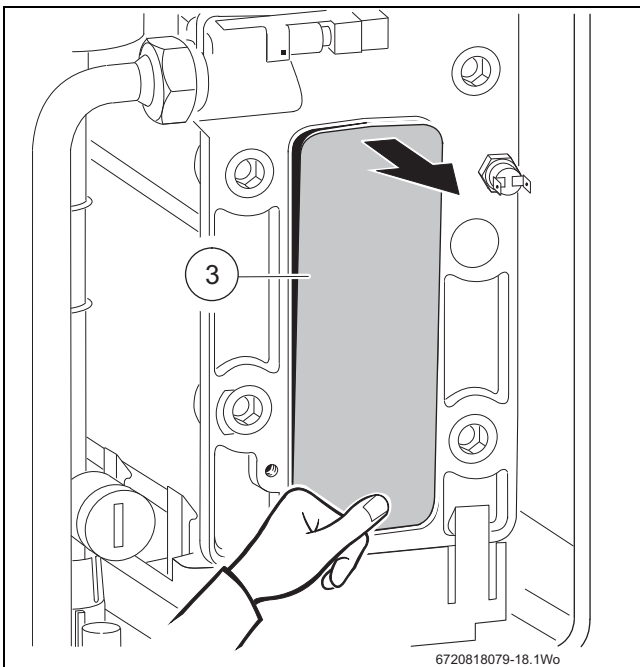

Fig. 52 Remove metal plate

- ▶ Using the cleaning blade, working from the bottom to the top, to loosen any deposits in the heat exchanger.

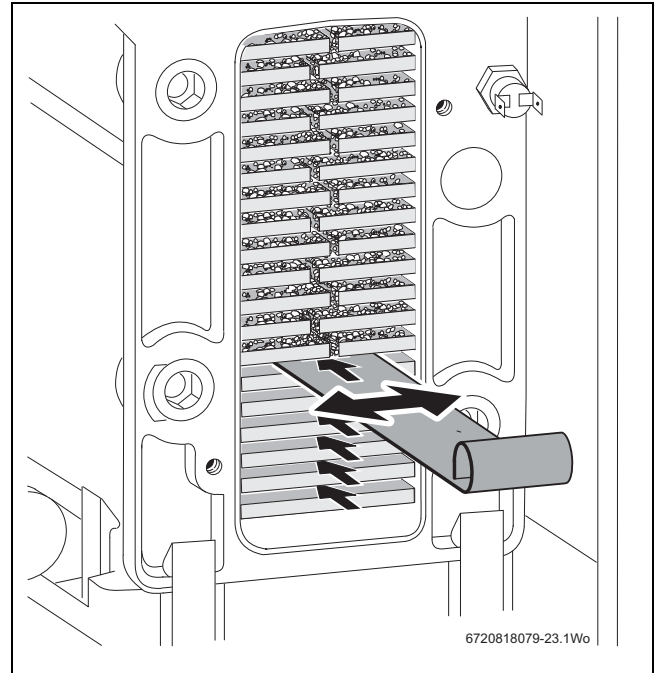

Fig. 53

- ▶ Using the brush, clean the heat exchanger from top to bottom.

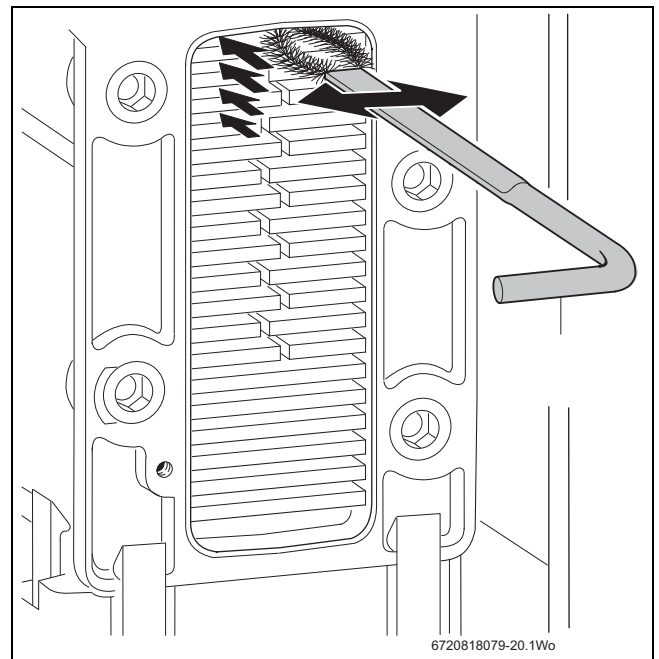

Fig. 54

- ▶ Use the handle of the brush to remove debris from the condensate tray.
- ▶ Place a suitable container under the sump condensate outlet to collect any water and debris.

- ▶ Pour water into the top of the heat exchanger to flush out the debris.

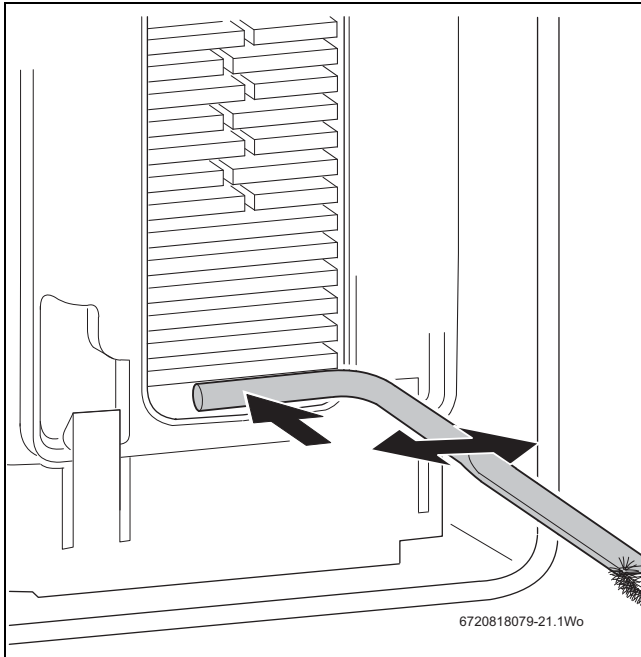

Fig. 55

- ▶ Refit the cleaning access cover assembly in reverse order, the metal plate [3] first, then the new seal [2], lastly the access cover [1].
- ▶ Refit the condensate trap.
- ▶ Pour 250ml of clean water into the heat exchanger to fill the condensate trap.
- ▶ Hand tighten the bolts and then use a spanner to tighten the bolts a further half turn.

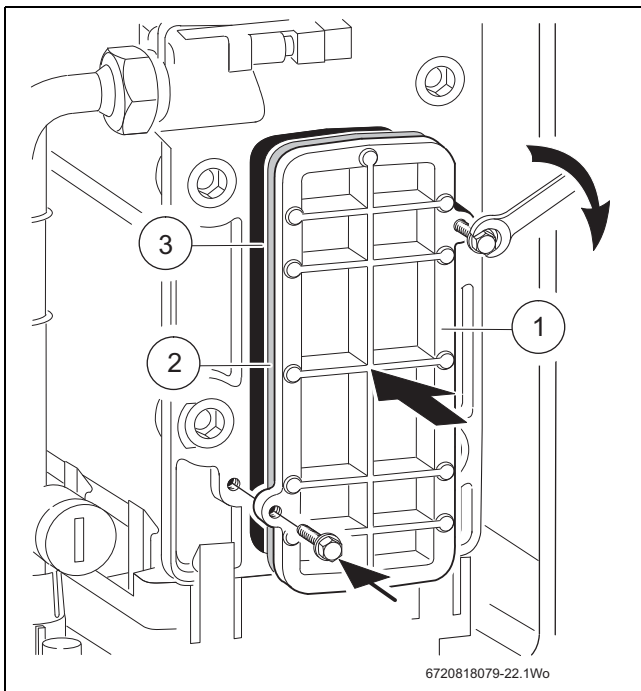

Fig. 56

6.7.5 Re-assembly of the burner cover



NOTICE: Burner gasket seal

- ▶ Always replace the burner seal with a new one when the joint has been disturbed.

- ▶ Refer to figure 48 and re-assemble the burner in reverse order
- ▶ Fit a new burner gasket seal [8].
- ▶ Refit the burner.
- ▶ Insert the burner cover under the rear nut [4a] and hand tighten.
- ▶ Assemble the washers/ spring [2b], and castellated nuts [2a], refer to figure 48, on to the studs [2] to secure the burner cover to the heat exchanger.
- ▶ Using a 10mm spanner, tighten the two castellated nuts [2a] until the burner cover bottoms out on the heat exchanger.
- ▶ Using a 13mm spanner tighten the rear nut [4a] until the burner cover bottoms out on the heat exchanger.
- ▶ The nuts will stop turning at this point, do not overtighten.
- ▶ If necessary, back the nuts off slightly until the hole for the clip [1] is visible.
- ▶ Insert the clips [1] and secure.
- ▶ After re-assembly check that the CO/CO₂ levels are as described in the section "Setting the air/gas ratio" on page 36.

6.8 Setting the air/gas ratio



NOTICE: SETTING THE AIR/GAS RATIO

- ▶ The air/gas ratio is factory set and should not normally need adjustment
- ▶ Only adjust if the values are still out of range when all other possible causes have been checked



NOTICE: COMBUSTION TESTING

- ▶ The setting of the air/gas ratio **must** be carried out by a competent registered gas engineer, such as a Gas Safe registered engineer or British Gas engineer. Setting of the air/gas ratio **must not** be attempted unless the person carrying out the test is equipped with a combustion analyser conforming to BS 7927 and is competent in its use.



All CO/CO₂ readings must be taken with the combustion chamber cover ON. Adjustments can only be made with the cover off.

To set the maximum CO₂:

- ▶ To adjust the CO₂ it will be necessary to first operate the boiler at maximum output
- ▶ Press and hold down the Service engineer button [1] for 10 seconds
- ▶ Turn temperature control [2] to maximum, the boiler will then go to maximum output



The control will resume normal operation after 15 minutes or if the Service engineer button [1] is pressed for more than one second.

- ▶ Remove the combustion chamber cover
- ▶ Remove plastic cap and using a flat bladed screwdriver
- ▶ Set the maximum CO₂ (+ or -) using the adjuster [3]
- ▶ Replace the combustion chamber cover
- ▶ Check the maximum CO₂ referring to table 15



CO₂ should be measured 10 minutes after firing the boiler

- ▶ Check the CO is less than 200ppm

- ▶ If further adjustment is required, remove the combustion chamber cover and set adjuster [3] as necessary
- ▶ Replace the cover and check the maximum CO₂ again

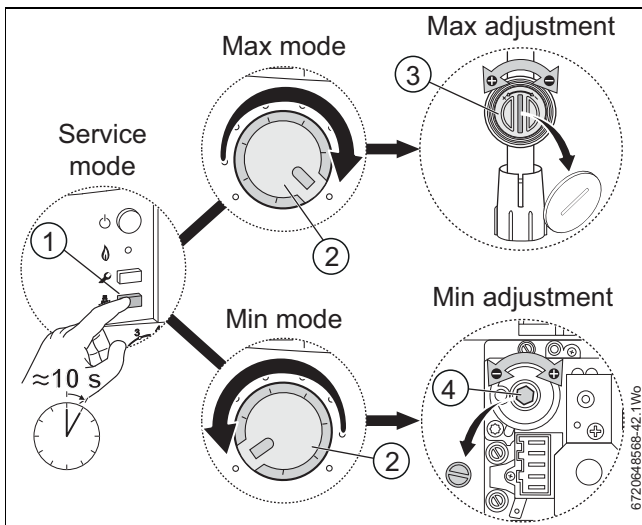

Fig. 57 Setting air/gas ratio

To set the minimum CO₂:

- ▶ Turn the temperature control [2] to minimum. This will make the boiler go to minimum output, allow the output to settle for approximately 10 minutes
- ▶ Remove the dust cap and adjust [4] on the gas valve
- ▶ Measure the minimum CO₂ and compare with the minimum output shown on the table 15
- ▶ Check that the CO is less than 200ppm
- ▶ Repeat the procedure until the correct output is achieved

Confirm the maximum CO₂

- ▶ Turn temperature control to maximum output and recheck the CO₂. If correct, hold down the Service engineer button [1] for two seconds, the boiler should return to normal operating mode with the blue power indicator permanently illuminated
- ▶ Remove the flue gas analyser
- ▶ Replace the cap over the flue gas sample point
- ▶ Remove the combustion chamber cover
- ▶ Replace the dust cover over the minimum output adjuster [4]
- ▶ Replace plastic cover to maximum outlet adjuster [3]
- ▶ Replace the combustion chamber cover

GAS TYPE	CO ₂ setting max.	CO ₂ setting min.
The CO₂ should be measured after 10 minutes		
Greenstar HF 440CDi^{ErP}		
Natural Gas	9.4 ± 0.2%	8.6 ± 0.2%
LPG (propane)	10.8 ± 0.2%	10.4 ± 0.2%
Greenstar HF 550CDi^{ErP}		
Natural Gas	9.4 ± 0.2%	9.0 ± 0.2%
LPG (propane)	10.8 ± 0.2%	10.4 ± 0.2%
CO - less than 200 ppm (0.002 ratio)		

Table 15 CO/CO₂ settings

6.9 Replacement parts

CAUTION: Isolate the boiler

- ▶ Turn off the gas supply and isolate the mains electrical supply before starting any work and observe all relevant safety precautions.
- ▶ Drain the boiler/system where necessary and protect any electrical equipment from water ingress during component replacement.

NOTICE: Gaskets and O rings

- ▶ Refit or replace any components removed from the appliance in the reverse order using new gaskets/'O' rings/sealant/heat transfer paste where necessary.
- ▶ Any 'O' ring or gasket that appears damaged must be replaced. Always check that any electrical connections are correctly made and that all screws are tight.

NOTICE: AFTER REPLACEMENT OF ANY COMPONENTS ALWAYS CHECK FOR GAS TIGHTNESS WHERE RELEVANT AND CARRY OUT FUNCTIONAL CHECKS AS DESCRIBED IN THE COMMISSIONING SECTION.

NOTICE: Service work

- ▶ Any service work must be carried out by competent registered gas engineer, such as a British Gas or other GAS SAFE registered engineer.
- ▶ After re-assembly the combustion must be checked using the procedure in the section "Setting the air/gas ratio". Measurement and setting of the gas ratio must not be attempted unless the person is equipped with a combustion analyser conforming to BS 7927 and is competent in its use.

6.9.1 Draining the appliance

- ▶ Turn off the system heating flow and return isolation valves - external to boiler.
- ▶ Unscrew the tank drain cap from the tank drain valve [1].
- ▶ Connect the hose connection and nut [4] (supplied with boiler, literature pack) to the tank drain valve [2].
- ▶ Attach a suitable hose [5], to the hose connector at the tank drain valve and route the other end of the hose to an external drain point.
- ▶ Fully open the drain tap [3] on the tank drain valve [1].
- ▶ Close the drain tap [3] when the flow from the appliance has stopped and remove the hose.

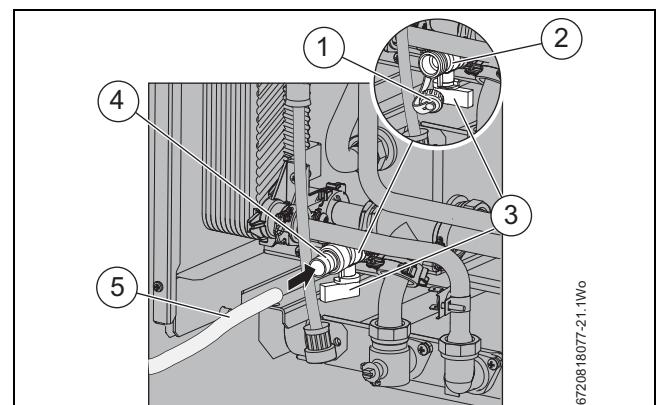

Fig. 58 Draining the boiler

i A small quantity of water may remain in some components even after the appliance has been drained. Protect any electrical components when removing components from the water circuits.

6.9.2 PCB Control board

Access to boiler control components

- ▶ Remove the screws [1] to release the cover from the controller.

PCB Fuse

- ▶ Remove the fuse [2] and replace with a spare that is clipped on the inside of the controller cover.

PCB

- ▶ Disconnect all electrical connections from the control board.
- ▶ Remove the screws [3] retaining the rear panel of the control and remove the panel.
- ▶ After re-assembly check CO/CO₂ levels as described in the section "Setting the air/gas ratio" on page 36.

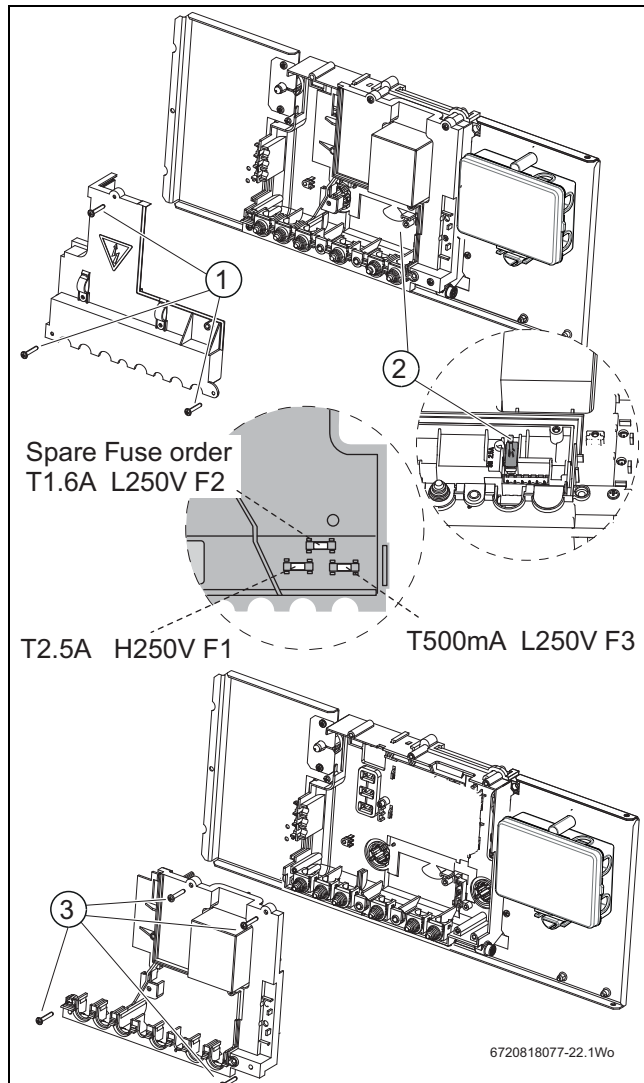

Fig. 59 PCB

6.9.3 Fan assembly:

i Do not attempt to service the fan assembly and flap valve if a CO/CO₂ analyser is not available.

- ▶ Undo lower pipe union on gas pipe [5].
- ▶ Twist the mixer unit [4] with gas pipe [5] to separate from fan [1].
- ▶ Remove fan lead and earth connector. The earth connector has a positive clip fixing.
- ▶ Remove fixing screws [3] attaching fan [1] to the burner cover [2].
- ▶ Remove fan [1].
- ▶ After re-assembly check that the CO/CO₂ levels are as described in the section "Setting the air/gas ratio".

Flap Valve:

- ▶ Undo lower pipe union on gas pipe [5].
- ▶ Remove pipe [5] by pushing upwards and towards the rear of the boiler.
- ▶ Twist the mixer unit [4] with gas pipe [5] to separate from the fan [1].
- ▶ Remove flap valve [6] from within fan intake [1] and replace.



Ensure the flap valve is fitted correctly with rubber flap upwards.

- ▶ After re-assembly check that the CO/CO₂ levels are as described in the section "Setting the air/gas ratio" on page 36.

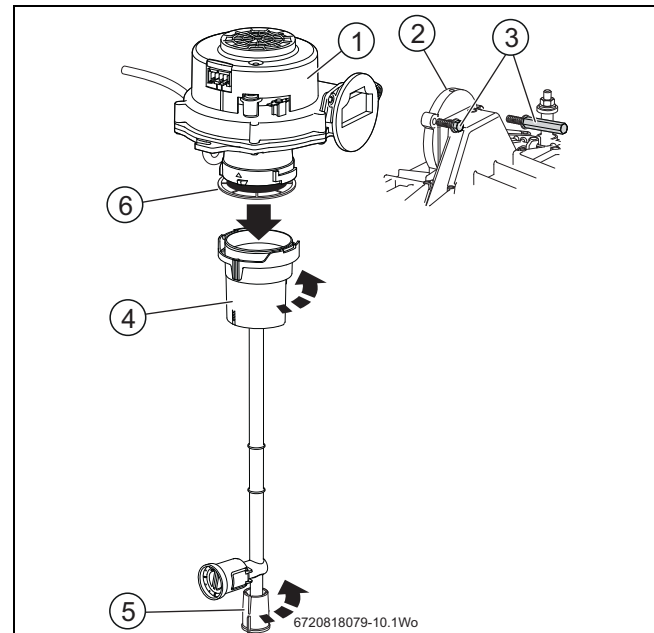

Fig. 60 Fan assembly

6.9.4 Condensate pump

- ▶ Disconnect electrical connections in control box, see wiring schematic in the 'Fault finding and Diagrams' section 7, page 43.
- ▶ Rotate the 15mm flexible tube [1] anti-clockwise and pull up to remove from the pump.
- ▶ Remove black flexible pipe [2] from condensate pump. Take care as there maybe condensate remaining in the pipe.
- ▶ Carefully remove the condensate pump [3] from the boiler and pour any excess condensate into a suitable container for safe disposal.

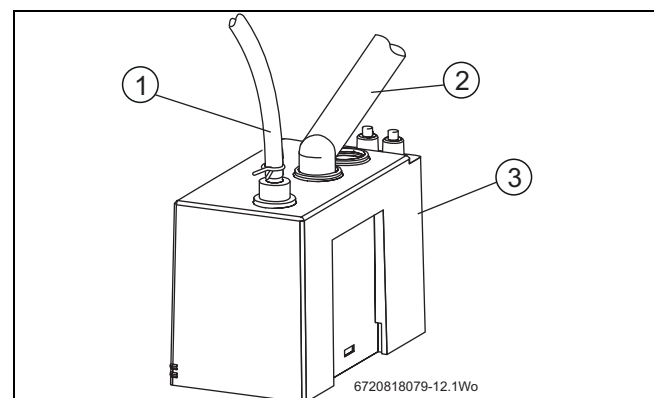

Fig. 61 Condensate pump

6.9.5 Diverter valve motor

- ▶ Ensure that the appliance is in service mode (there is no need to drain the appliance).
- ▶ Disconnect the connector [2] from diverter valve motor [1].
- ▶ Pull the motor [1] to you, the assembly will slide free from the valve.
- ▶ To refit, follow the reverse of above.



In case of problems when refitting the motor: connect the electrical connector to the motor and switch the appliance on. When the motor goes into the middle position the motor can be fitted without difficulty.

6.9.6 Diverter valve

- ▶ Ensure that the appliance has been fully drained.
- ▶ Disconnect the connector [2] from diverter valve motor [1].
- ▶ Undo the two screws holding the valve actuator body [4] to the plastic housing [3].
- ▶ Remove the motor and valve actuator body from the diverter valve.
- ▶ Withdraw the valve actuator from the diverter valve.
- ▶ To refit assemble in reverse, ensuring that the valve actuator is properly seated on the two lugs of the actuator body.

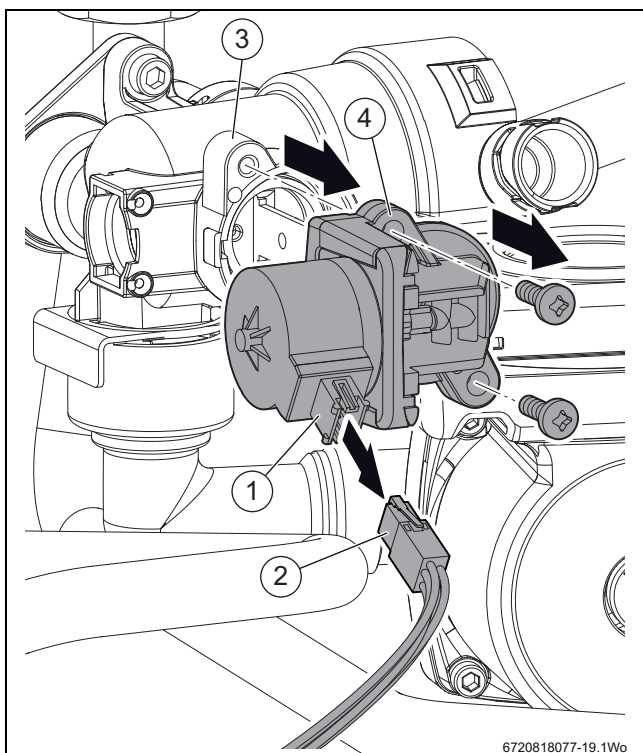

Fig. 62 Diverter valve assembly

6.9.7 Pump removal

- ▶ Refer to figure 63
- ▶ Isolate the appliance from the power supply.
- ▶ Turn off all the isolation valves
- ▶ Drain the appliance, refer to section 6.9.1.
- ▶ Disconnect the pump control plug [1] and power plug [2]
- ▶ Pull out the retaining clip [3] securing pipe [4]
- ▶ Release the pipe from the HE [4] and swing away from the pump.
- ▶ Release the nut [5], lift the pump slightly to clear the pump support
- ▶ Pull the pump away from the pipe to the diverter valve and remove.
- ▶ Re-assembly is a reverse of this procedure

Pump head removal

Alternatively, after isolating and draining the appliance:

- ▶ Disconnect electrical plugs [1] and [2]
- ▶ Remove the four Allen screws [6] and pull the pump head off.
- ▶ Re-assembly is a reverse of this procedure

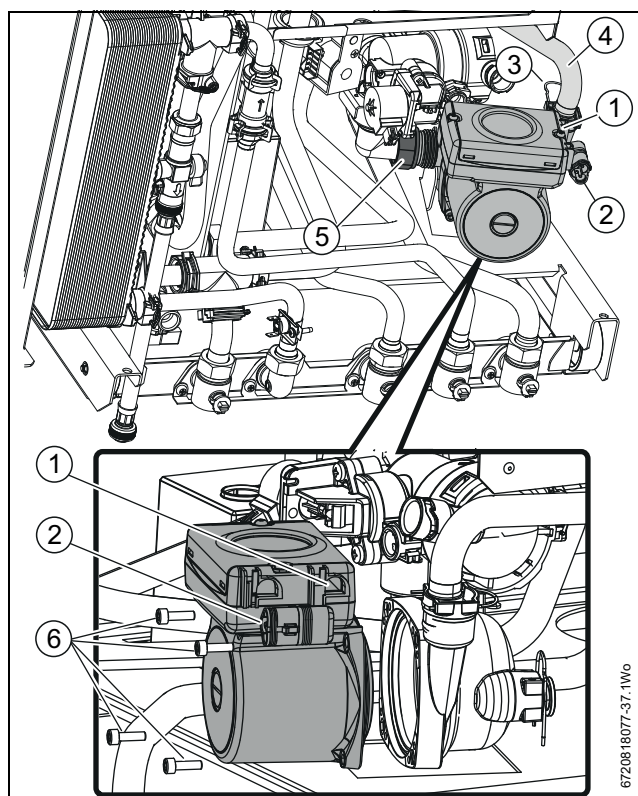

Fig. 63 Pump and pump head removal

6.9.8 Sample points

Air sampling point [1]

See section 6.5 on page 33, Checking flue integrity

Flue Gas sampling point [2]

See section 6.6 on page 33, Flue gas analysis

6.9.9 Sensors

- ▶ Check that the appliance is electrically isolated.

Central heating flow temperature sensor [3]:

- ▶ Remove the connector.
- ▶ Release the sensor clip and withdraw the sensor.
- ▶ Apply heat transfer paste to the replacement sensor.

Tank overhear thermostat [4]:

- ▶ Remove the screws retaining plastic cover.
- ▶ Remove the cover and disconnect 2 electrical connections.
- ▶ Unscrew the two hexagon studs.
- ▶ Replace the sensor, coating surface with paste supplied.
- ▶ Re-assemble.

Tank sensor [5]:

- ▶ Remove the screws retaining plastic cover.
- ▶ Remove the cover and disconnect the two electrical connections.
- ▶ Unscrew 2 hexagon studs.
- ▶ Replace the sensor, coating surface with paste supplied.
- ▶ Re-assemble.

Flow sensor/flow regulator assembly [6]:

- ▶ Shut off the mains water at inlet valve and drain DHW circuit.
- ▶ Disconnect the in-line connector.
- ▶ Remove the two retaining clips [7].
- ▶ Remove the flow sensor assembly [6].
- ▶ Remove the brass housing with flow regulator [8] from sensor.
- ▶ Re-assemble ensuring that retaining clips are correctly positioned.

Flue Temperature limiter [9]

- ▶ Remove the connector.
- ▶ Using a small terminal screwdriver, prise the sensor and grommet from the plastic housing. Take care not to damage the plastic housing.

Domestic hot water temperature sensor [10]:

- ▶ Release and pull-off the electrical connectors.
- ▶ Unscrew the bracket.
- ▶ Replace the sensor coating surface with paste supplied.
- ▶ Re-assemble ensuring the sensor is in contact with the flat section of pipe.

Safety temperature limiter [11]:

- ▶ Remove the connectors.
- ▶ Unscrew the sensor.

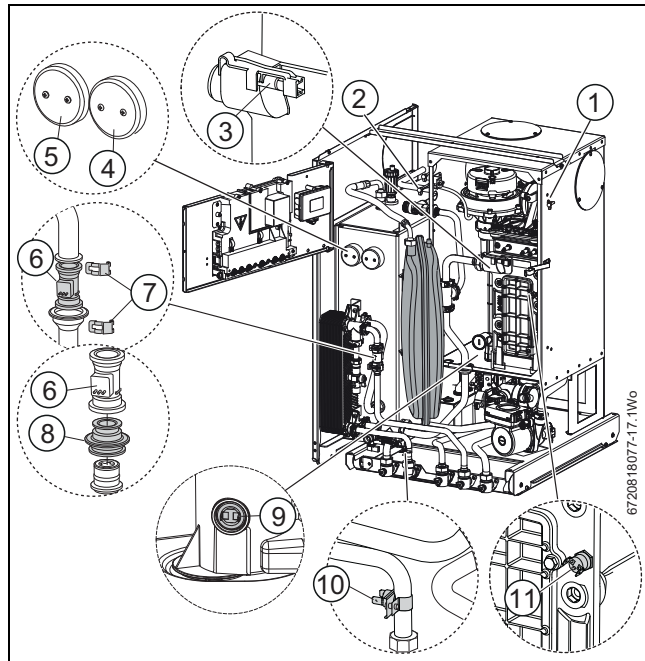

Fig. 64 Sensors

6.9.10 Domestic hot water heat exchanger

- ▶ Before removing the heat exchanger, close the mains water inlet isolation valve and drain the hot water circuit. Close the CH isolating valves and drain the appliance.
The pipe [2] may be removed between the flow sensor outlet and the plate heat exchanger to improve access to the rear connections.
- ▶ Undo the two screws securing the plastic housing to the heat exchanger.
- ▶ Remove the heat exchanger.
- ▶ To refit, follow the above in reverse. Ensure any seals that have been disturbed are replaced.

6.9.11 Pressure gauge:

- ▶ Drain the appliance.
- ▶ Unplug the connection to the pressure relief valve.
- ▶ Release the pressure gauge from the clips on the rear of the control panel.

6.9.12 Expansion vessel:

- ▶ Drain the appliance.
- ▶ Move the control panel into service position.
- ▶ Remove the locking screw [3] from vessel bracket.
- ▶ Undo the union connection at the top of the vessel.
- ▶ Swing the expansion vessel out and lift off the brackets.
- ▶ Set the pressure of the new vessel to that required by the system.

6.9.13 Pressure relief valve PRV:

- ▶ Drain the appliance.
- ▶ Disconnect the drain pipe from the valve [4]
- ▶ Undo the nut retaining the PRV to the flow pipe.
- ▶ Remove the clip from the PRV and disconnect the pressure gauge.
- ▶ Remove the valve.
- ▶ Replace the sealing washer and fit a new valve.

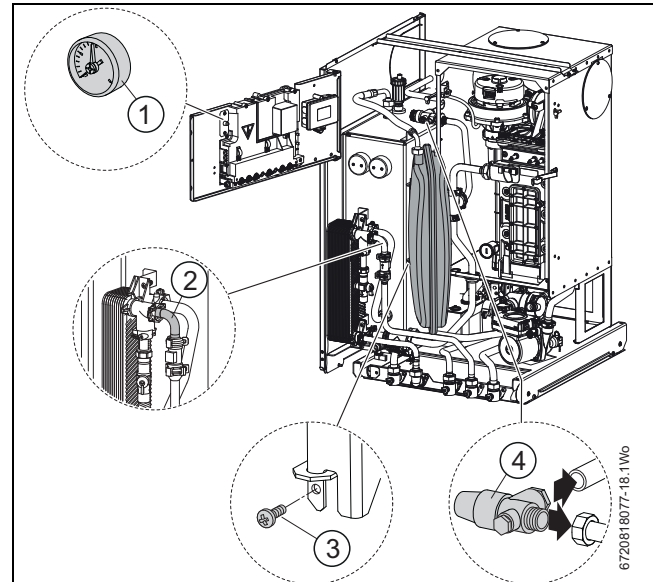

Fig. 65 Replacement parts

6.9.14 Condensate trap

- ▶ Remove the condensate pump, refer to section 6.9.4 on page 38
- ▶ Remove the screw retaining the trap
- ▶ Rotate the condensate trap by 90°
- ▶ Pull the trap down from the sump connection
- ▶ Angle the trap backwards and remove from the boiler
- ▶ Before replacing the trap, fill with at least 250ml of clean water
- ▶ Replacing the trap is the reverse of the removal procedure
- ▶ Reconnect the condensate pump and reconnect the pipe from the trap
- ▶ Reconnect the condensate disposal pipe

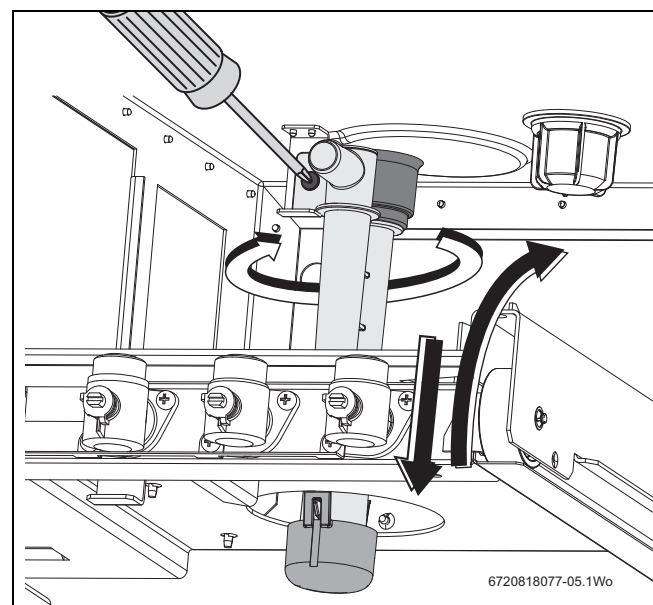

Fig. 66 Condensate trap access

6.9.15 Gas valve

- ▶ Check that the gas cock is turned off.
- ▶ Disconnect the black rubber tube [1] from the gas valve.
- ▶ Remove the solenoid connections [2] at the side of the gas valve.
- ▶ Release the gas inlet union [3] at the inlet.
- ▶ Undo the union [4], within the inner casing, securing the valve to the gas/air tube.
- ▶ Transfer the inlet pipe assembly to the new gas valve.
- ▶ Reconnect the plastic union [4] to the gas valve.
- ▶ Reconnect the solenoid connection [2].
- ▶ Re-attach the black rubber tube [1] to the gas valve
- ▶ Check for gas tightness when the new gas valve has been fitted.
- ▶ After re-assembly check CO/CO₂ levels as described in the section "Setting the air/gas ratio" on page 36.

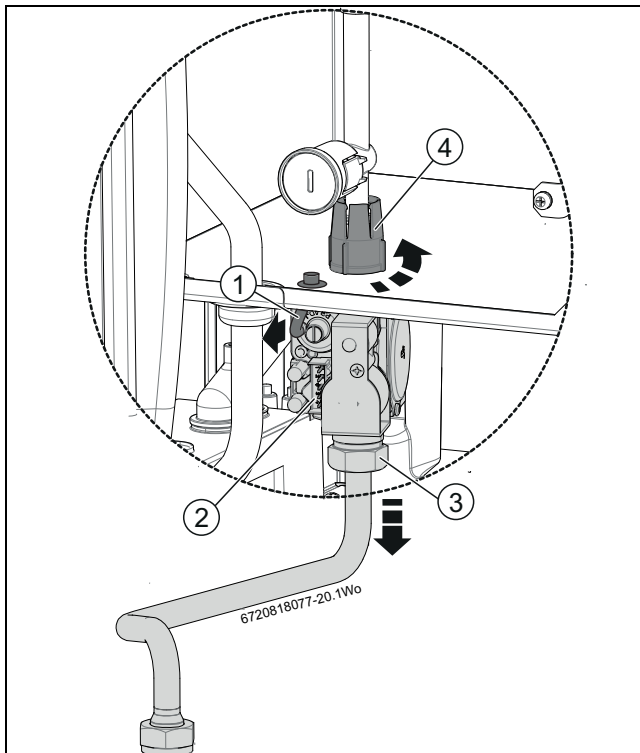

Fig. 67 Gas valve

6.9.16 Electrode assembly and heatshield

WARNING: Electrode assembly

- ▶ Do not remove the electrode assembly unless a new gasket is available for re-assembly.

- ▶ Switch off the master switch.
- ▶ Isolate the appliance from the power supply.
- ▶ Move the control panel and expansion vessel into the service position.
- ▶ Release the 4 screws to remove the inner case door.
- ▶ Remove the leads from the electrodes.
- ▶ Unscrew the two fixing screws [2] and carefully remove the electrode assembly [1].
- ▶ Inspect the spark/flame electrode assembly and ceramics for signs of contamination or damage, replace as necessary.
- ▶ Re-assemble the electrode set with a new gasket and secure with the screws [2] removed earlier.
- ▶ After re-assembly check that the CO/CO₂ levels as described in the section "Setting the air/gas ratio" on page 36.

6.9.17 Burner

WARNING: Burner

- ▶ Do not remove the burner unless a new gasket is available for re-assembly.

- ▶ Turn the gas cock and the master switch to their OFF positions.
- ▶ Isolate the appliance from the power supply.
- ▶ Remove the clips [3a], castellated nuts [3b] and springs [3c] from the studs [3].
- ▶ Remove the nut [4a] from the rear stud [4].
- ▶ Disconnect the mixer unit from the fan.
- ▶ Remove the connector and earth wire from the fan.
- ▶ Remove the burner cover plate [5] and fan assembly [6].
- ▶ Remove the burner [7].
- ▶ Re-assemble the new burner in reverse order.
- ▶ Replace the burner seal [8] with a new one.
- ▶ Refer to the section "Re-assembly of the burner cover" on page 36.
- ▶ After re-assembly check that the CO/CO₂ levels as described in the section "Setting the air/gas ratio" on page 36

6.9.18 Primary heat exchanger:

- ▶ Isolate the appliance from the power supply.
- ▶ Turn off all the isolation valves.
- ▶ Drain down the appliance.
- ▶ Move the control panel and the expansion vessel into the service position.
- ▶ Remove the inner case door.
- ▶ Remove the fan assembly, burner, and gas mixing unit.
- ▶ Disconnect and remove the sensors connected to heat exchanger.
- ▶ Remove the condensate trap.
- ▶ Remove the internal flue elbow and tube from the boiler sump.
- ▶ Release the return pipe union [10] at the base of the heat exchanger.
- ▶ Remove the plastic nut [11] from the base of the inner casing.
- ▶ Release the retaining bracket [9] from the inner chassis
- ▶ Remove the heat exchanger from inner casing.
- ▶ Ensure that heat conductive paste is used on sensors when refitting.
- ▶ Check the seals and replace if necessary.
- ▶ After re-assembly check that the CO/CO₂ levels are as described in the section "Setting the air/gas ratio" on page 36.

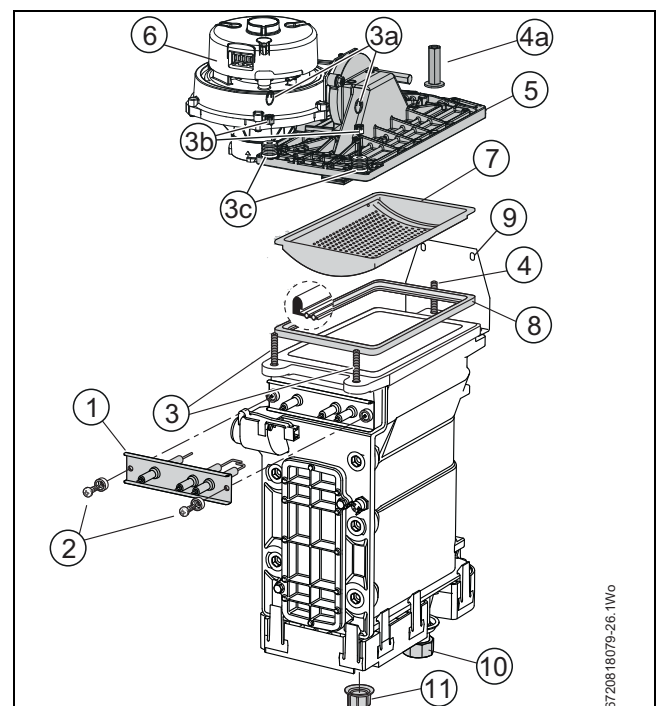

Fig. 68 Primary heat exchanger

6.10 Short parts list

	Burner 8 737 703 148 GC No. E27 200		Burner seal 8 711 004 168 0 GC No. E27 201		Fan 440 CDi 8 716 117 325 GC No. E74-539
	Fan 550 CDi 8 718 644 395 0 GC No. N/A		Pump 8 716 117 455 GC No. J25 460		Diverter valve assembly 8 716 106 845 0 GC No. H02 533
	Diverter valve motor 8 716 106 847 0 CG No. H02 534		Flow turbine 8 717 002 132 0 GC No. H21 232		Flow regulator 440 CDi 20 litre beige 8 717 002 135 0 GC No. H21 235
	Flow regulator 550 CDi 25 litre light grey 8 718 681 198 0 GC No. H66 928		Flow NTC 8 714 500 087 0 GC No. E74 536		Heat exchanger overheat stat 8 714 500 056 GC No. H08 291
	DHW NTC 8 716 142 302 0 GC No. 375 696		Tank NTC 8 716 142 319 0 GC No. 379 785		Tank OH stat 8 716 103 217 0 GC No. E82 394
	Heat exchanger 440 CDi 8 716 108 212 0 GC No. H22 465		Heat exchanger 550 CDi 8 718 680 648 0 GC No. H66 931		Gas valve 8 716 118 167 GC No. H56 469
	Condensate pump 8 716 114 077 0 GC No. H66 921		Pressure relief valve 8 718 686 507 0 GC No. 386 789		Pressure gauge 8 716 116 428 0 GC No. H66 930
	Auto air vent 8 718 505 041 0 GC No. E00 717		Set of electrodes including seal 8 718 664 301 0		Expansion vessel 8 715 407 288 0 GC No. H21 242
	Control unit 8 716 117 678 0		Flue overheat stat 8 710 506 267		Heat exchanger inspection cover seal 8 710 103 153 0

Table 16

7 FAULT FINDING AND DIAGRAMS

7.1 Electrical wiring diagram

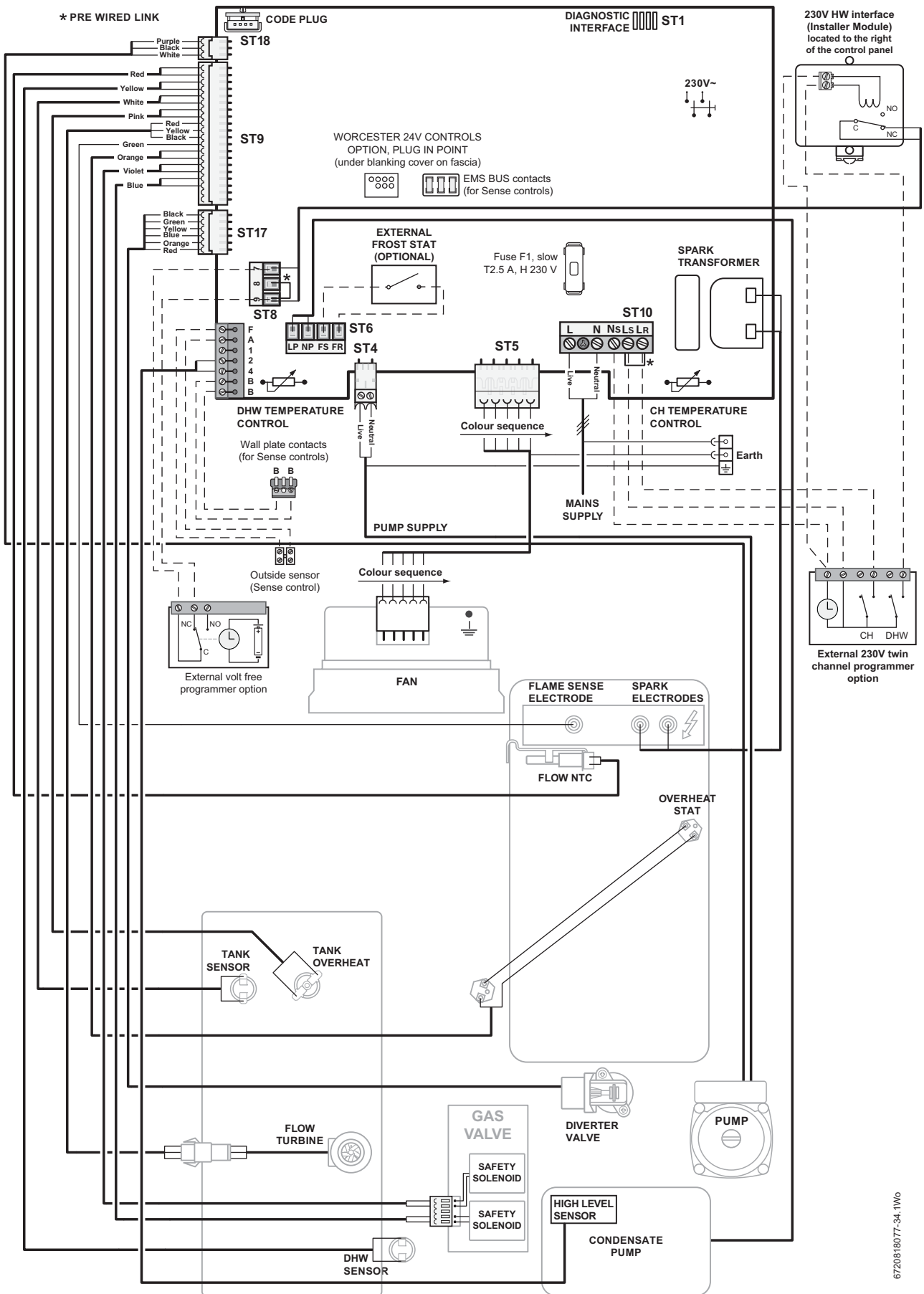

6720818077-34-1W0

7.3 DHW function

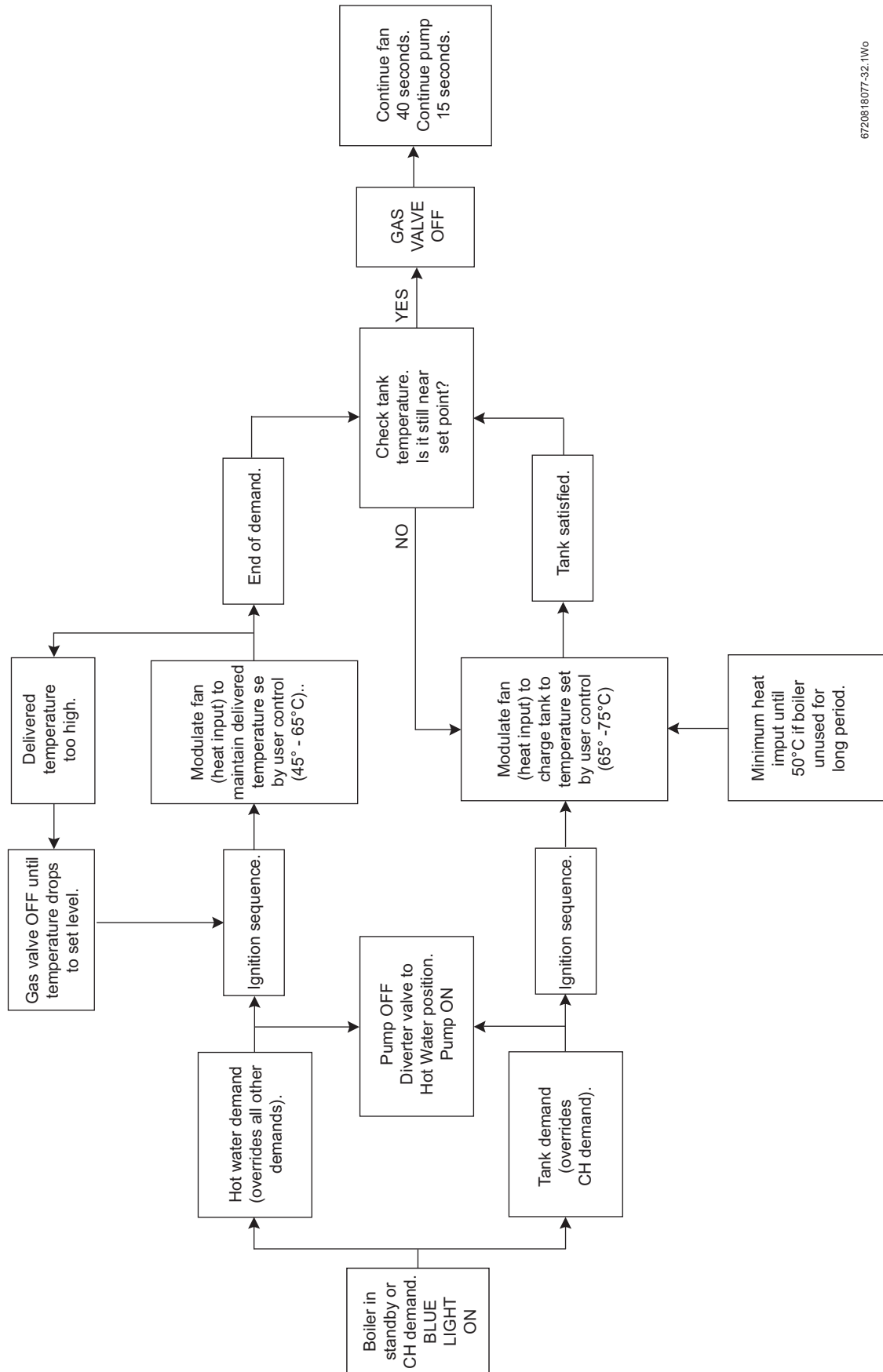

6720818077-32.1W0

7.4 Protection function

AUTOMATIC INTERNAL FROST FUNCTION

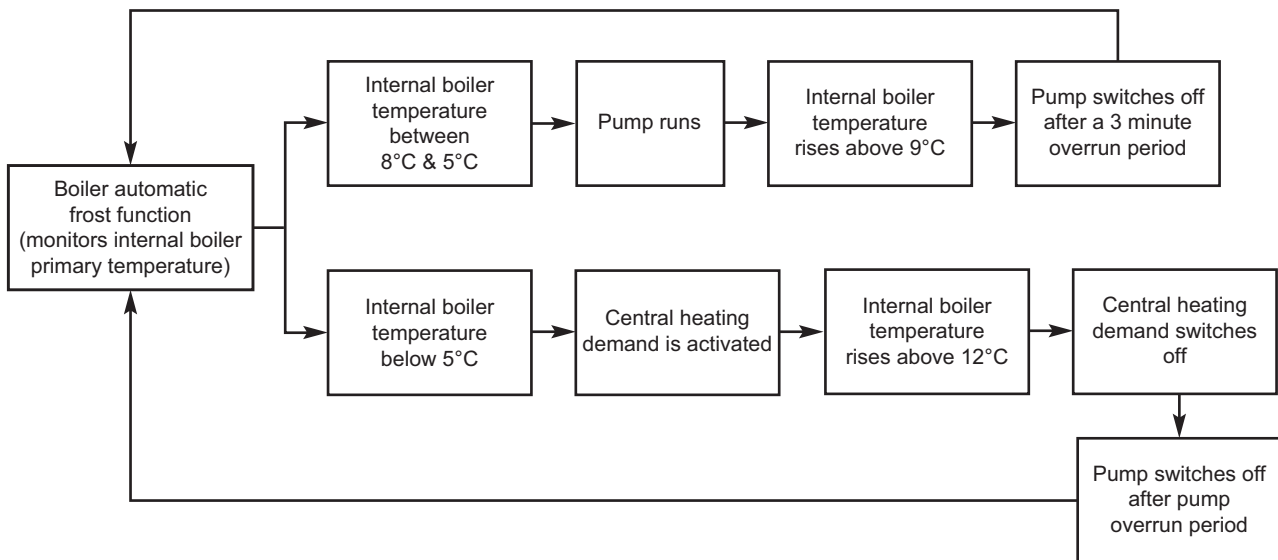

PUMP OVERRUN FUNCTION

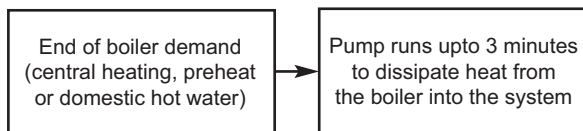

PUMP ANTISEIZE FUNCTION

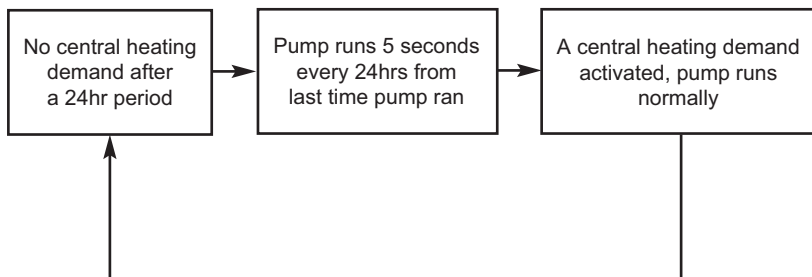

6720648665-36.1Wo

7.5 Fault finding



- ▶ This fault finding information is for guidance only. Worcester Bosch cannot be held responsible for costs incurred by persons not deemed to be competent.
- ▶ The electronic control system for this boiler incorporates a blue central indicator. This normally confirms the permanent mains supply, but, by flashing during a fault, provides a guide to the cause as listed.
- ▶ This fault finding system assumes that the appliance has been operating normally until the time of failure (i.e. not a first time installation error).

BOILER - FAULTS AND CONDITIONS		
Display code:	Fault description	Check, repair/replace as necessary
A1	Pump dry run detection or Pump is running in air	Check the system pressure, refill if necessary
A5	Tank NTC defect	Check tank NTC sensor and leads, measure resistance across NTC (33.5k Ω - 500 Ω)
A7	DHW NTC defect	Check DHW NTC sensor and leads, measure resistance across NTC (33.5k Ω - 500 Ω)
A8	EMS communication error	Check electrical connections of EMS controls (if fitted), connections on the control board, replace control board.
b1	Code plug not detected	Insert code plug correctly, test and replace as necessary.
b2, b3, b4, b5,b6	Data error	Replace control board.
b7	Burner control error	Replace control board.
C6	Fan defect	Check fan, lead, and connector, replace as necessary.
d3	External temp limiter	Check plug connector ST8, link missing/damaged between 8 & 9 on ST8.
d5	Condensate pump failure	See condensate pump table.
d6	Internal heat bank overflow	Check system pressure, tank overheat thermostat and leads, and pump operation
EA	Flame not detected	Check gas is present and working gas pressure, ignition electrodes and harness, flame sense electrode and harness, and operation of gas valve. Replace as necessary.
E2	Primary NTC defect	Check primary NTC sensor and leads, resistance across NTC should be between 36k to 1k Ω
E9	OH stat tripped	Check system pressure, over heat thermostat, and pump operation. Check fuse (T1.6A slow blow), replace as necessary.
F0	Internal error	Check all electrical connections, replace control board as necessary.
F1	ROM error check	Check all electrical connections, replace control board as necessary.
F7	Flame detected after appliance shut off	Check flame sense electrode and harness, and control board for signs of water damage. Replace as necessary
FA	Flame detected after gas shut off	Check flame sense electrode and harness, and control board for signs of water damage. Check gas valve operation. Replace as necessary
Fd	Reset button pressed	Press reset button again

Table 17

Preliminary checks:

Preliminary electrical system checks are the first electrical checks to be carried out during a fault finding procedure.

On completion of the Service/Fault finding task which has required the breaking and remaking of electrical connections, check:

- a) EARTH CONTINUITY
- b) SHORT CIRCUIT CHECK
- c) POLARITY
- d) RESISTANCE TO EARTH.

7.6 Condensate pump Indicator lights

The condensate pump has indicator lights [1] which show operation status or a fault condition.

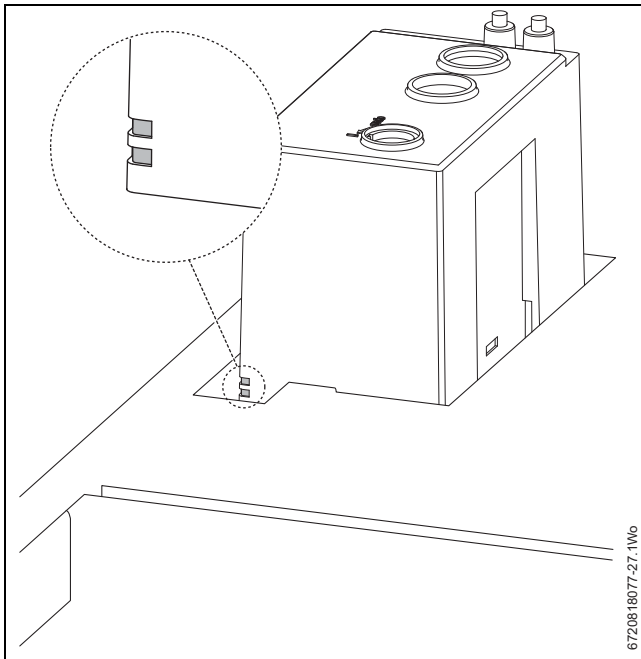

Fig. 69 Condensate pump indicator lights

CONDENSATE PUMP - OPERATING LIGHTS AND FAULT CONDITIONS:			
Ready for operation = Steady green light			
Fault = Red light			
Pump running = Flashing green light			
Operating lamps		Cause	Solution
Green	Red		
Off	Off	Mains supply not connected Power failure	Connect mains supply Check mains and fuse/circuit breaker
Flashing	Flashing	Dry-run (possible air in pump)	Pump restarts automatically after one minute
On	Flashing	Pump blocked	Visually inspect the pump inlet and tank. Remove or rinse out any dirt or foreign bodies
On	On	Level exceeds alarm level	Discharge hose or non-return valve blocked Possible kink in discharge hose (clean or remove kink if applicable)
Off	Flashing	Pump blocked and alarm level exceeded	Visually inspect the pump inlet and tank. Remove or rinse out any dirt or foreign bodies

Notes

GAS BOILER SYSTEM COMMISSIONING CHECKLIST (for installations up to 70kW net input)

This Commissioning Checklist is to be completed in full by the competent person who commissioned the boiler as a means of demonstrating compliance with the appropriate Building Regulations and then handed to the customer to keep for future reference.

Failure to install and commission according to the manufacturer's instructions and complete this Benchmark Commissioning Checklist will invalidate the warranty. This does not affect the customer's statutory rights.

Customer name:				Telephone number:			
Address:							
Boiler make and model:							
Boiler serial number:							
Commissioned by (PRINT NAME):				Gas Safe register number:			
Company name:				Telephone number:			
Company address:							
				Commissioning date:			
To be completed by the customer on receipt of a Building Regulations Compliance Certificate*							
Building Regulations Notification Number (if applicable):							
CONTROLS (tick the appropriate boxes)							
Time and temperature control to heating		Room thermostat and programmer/timer		Programmable room thermostat			
		Load/weather compensation		Optimum start control			
Time and temperature control to hot water		Cylinder thermostat and programmer/timer		Combination Boiler			
Heating zone valves		Fitted		Not required			
Hot water zone valves		Fitted		Not required			
Thermostatic radiator valves		Fitted		Not required			
Automatic bypass to system		Fitted		Not required			
Boiler interlock				Provided			
ALL SYSTEMS							
The system has been flushed and cleaned in accordance with BS7593 and boiler manufacturer's instructions						Yes	
What system cleaner was used?							
What inhibitor was used?						Quantity	
						litres	
Has a primary water system filter been installed?						Yes	
						No	
CENTRAL HEATING MODE measure and record:							
Gas rate		m ³ /hr		OR		ft ³ /hr	
Burner operating pressure (if applicable)		mbar		OR Gas inlet pressure		mbar	
Central heating flow temperature						°C	
Central heating return temperature						°C	
COMBINATION BOILERS ONLY							
Is the installation in a hard water area (above 200ppm)?						Yes	
						No	
If yes, and if required by the manufacturer, has a water scale reducer been fitted?						Yes	
						No	
What type of scale reducer has been fitted?							
DOMESTIC HOT WATER MODE Measure and Record:							
Gas rate		m ³ /hr		OR		ft ³ /hr	
Burner operating pressure (at maximum rate)		mbar		OR Gas inlet pressure at maximum rate		mbar	
Cold water inlet temperature						°C	
Hot water has been checked at all outlets						Yes	
						Temperature	
						°C	
Water flow rate						l/min	
CONDENSING BOILERS ONLY							
The condensate drain has been installed in accordance with the manufacturer's instructions and/or BS5546/BS6798						Yes	
ALL INSTALLATIONS							
Record the following:		At max. rate:		CO		ppm	
		AND		CO/CO ₂		Ratio	
		At min. rate: (where possible)		CO		ppm	
		AND		CO/CO ₂		Ratio	
The heating and hot water system complies with the appropriate Building Regulations						Yes	
The boiler and associated products have been installed and commissioned in accordance with the manufacturer's instructions						Yes	
The operation of the boiler and system controls have been demonstrated to and understood by the customer						Yes	
The manufacturer's literature, including Benchmark Checklist and Service Record, has been explained and left with the customer						Yes	
Commissioning Engineer's Signature							
Customer's Signature							
(To confirm satisfactory demonstration and receipt of manufacturer's literature)							

*All installations in England and Wales must be notified to Local Authority Building Control (LABC) either directly or through a Competent Persons Scheme. A Building Regulations Compliance Certificate will then be issued to the customer.



SERVICE RECORD

It is recommended that your heating system is serviced regularly and that the appropriate Service Interval Record is completed.

Service Provider

Before completing the appropriate Service Record below, please ensure you have carried out the service as described in the manufacturer's instructions. Always use the manufacturer's specified spare part when replacing controls.

SERVICE 01					Date:
Engineer name:					
Company name:					
Telephone No:					
Gas safe register No:					
Record:	At max. rate:	CO	ppm	AND	CO ₂ %
	At min. rate: (Where Possible)	CO	ppm	AND	CO ₂ %
Comments:					
Signature					

SERVICE 02					Date:
Engineer name:					
Company name:					
Telephone No:					
Gas safe register No:					
Record:	At max. rate:	CO	ppm	AND	CO ₂ %
	At min. rate: (Where Possible)	CO	ppm	AND	CO ₂ %
Comments:					
Signature					

SERVICE 03					Date:
Engineer name:					
Company name:					
Telephone No:					
Gas safe register No:					
Record:	At max. rate:	CO	ppm	AND	CO ₂ %
	At min. rate: (Where Possible)	CO	ppm	AND	CO ₂ %
Comments:					
Signature					

SERVICE 04					Date:
Engineer name:					
Company name:					
Telephone No:					
Gas safe register No:					
Record:	At max. rate:	CO	ppm	AND	CO ₂ %
	At min. rate: (Where Possible)	CO	ppm	AND	CO ₂ %
Comments:					
Signature					

SERVICE 05					Date:
Engineer name:					
Company name:					
Telephone No:					
Gas safe register No:					
Record:	At max. rate:	CO	ppm	AND	CO ₂ %
	At min. rate: (Where Possible)	CO	ppm	AND	CO ₂ %
Comments:					
Signature					

SERVICE 06					Date:
Engineer name:					
Company name:					
Telephone No:					
Gas safe register No:					
Record:	At max. rate:	CO	ppm	AND	CO ₂ %
	At min. rate: (Where Possible)	CO	ppm	AND	CO ₂ %
Comments:					
Signature					

SERVICE 07					Date:
Engineer name:					
Company name:					
Telephone No:					
Gas safe register No:					
Record:	At max. rate:	CO	ppm	AND	CO ₂ %
	At min. rate: (Where Possible)	CO	ppm	AND	CO ₂ %
Comments:					
Signature					

SERVICE 08					Date:
Engineer name:					
Company name:					
Telephone No:					
Gas safe register No:					
Record:	At max. rate:	CO	ppm	AND	CO ₂ %
	At min. rate: (Where Possible)	CO	ppm	AND	CO ₂ %
Comments:					
Signature					

SERVICE 09					Date:
Engineer name:					
Company name:					
Telephone No:					
Gas safe register No:					
Record:	At max. rate:	CO	ppm	AND	CO ₂ %
	At min. rate: (Where Possible)	CO	ppm	AND	CO ₂ %
Comments:					
Signature					

SERVICE 10					Date:
Engineer name:					
Company name:					
Telephone No:					
Gas safe register No:					
Record:	At max. rate:	CO	ppm	AND	CO ₂ %
	At min. rate: (Where Possible)	CO	ppm	AND	CO ₂ %
Comments:					
Signature					

*All installations in England and Wales must be notified to Local Authority Building Control (LABC) either directly or through a Competent Persons Scheme. A Building Regulations Compliance Certificate will then be issued to the customer.



Worcester, Bosch Group
Cotswold Way, Warndon, Worcester WR4 9SW.
Tel. 0330 123 9559

Worcester, Bosch Group is a brand name of Bosch Thermotechnology Ltd.
worcester-bosch.co.uk

6 720 818 077 (2016/04)

WORCESTER, BOSCH GROUP:

TECHNICAL SUPPORT:	0330 123 3366
APPOINTMENTS:	0330 123 9339
SPARES:	0330 123 9779
LITERATURE:	0330 123 9119
TRAINING:	0330 123 0166
SALES:	0330 123 9669



WORCESTER
Bosch Group