

INSTRUCTION MANUAL

INSTALLATION COMMISSIONING & SERVICING

FLOOR STANDING RSF GAS-FIRED CONDENSING COMBINATION
BOILER

GREENSTAR HIGHFLOW 440CDi & 550CDi

FOR SEALED CENTRAL HEATING SYSTEMS AND MAINS FED DOMESTIC HOT WATER

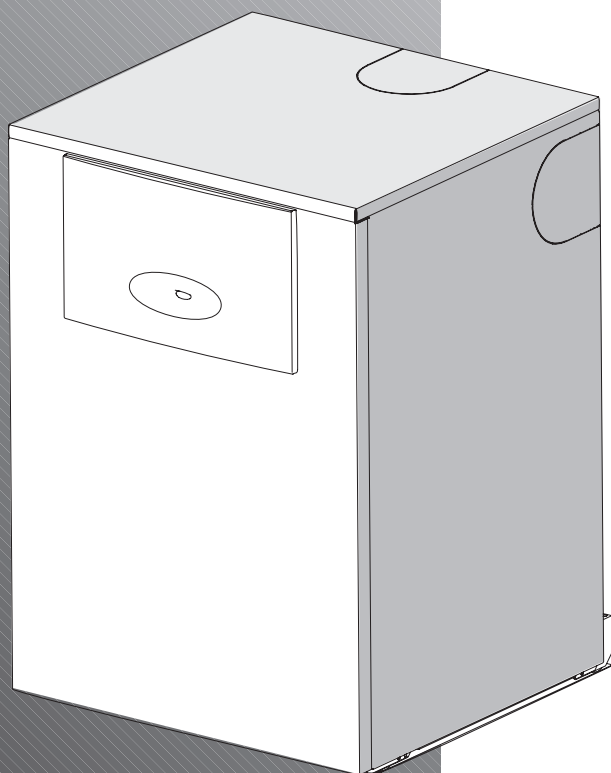

THE APPLIANCE IS FOR USE WITH
NATURAL GAS OR L.P.G. (Cat II 2H3P TYPE C13, C33 & C93)

NATURAL GAS:
GREENSTAR HIGHFLOW 440CDi GC NUMBER 47-406-24
GREENSTAR HIGHFLOW 550CDi GC NUMBER 47-406-25

LIQUID PETROLEUM GAS:
GREENSTAR HIGHFLOW 440CDi GC NUMBER 47-406-26
GREENSTAR HIGHFLOW 550CDi GC NUMBER 47-406-27



WORCESTER
Bosch Group

CONTACT INFORMATION

WORCESTER, BOSCH GROUP:

MAIN RECEPTION: 01905 754624
MAIN FAX: 01905 754619
TECHNICAL: 08705 266241
SERVICE: 08457 256206
SPARES: 01905 752571
LITERATURE: 01905 752556
TRAINING: 01905 752526
SALES: 01905 752640
WEBSITE: worcester-bosch.co.uk

WATER TREATMENT:

FERNOX 01799 550811
fernox.com

SENTINEL 0800 389 4670
sentinel-solutions.net

FLUE TERMINAL GUARDS:

TOWER FLUE COMPONENTS
VALE RISE, TONBRIDGE, TN9 1TB
TEL: 01732 351680
tfc-group.co.uk

IMPORTANT HANDLING INSTRUCTIONS:

It is advised that at least two people are involved in the transfer of the packaged appliance from the van to the point of installation.

A suitable truck should be used.

The boiler is secured to a wooden board with screws. It is advised that no attempt should be made to move the packaged appliance without the use of a suitable truck.

Before removing the carton it is advised that the top flaps are opened and the ancillary items removed and set to one side.

The carton can now be lifted off the boiler.

Remove the plastic bag protecting the boiler surfaces and place safely away from the working area.

Remove the boiler (complete with board) from the pallet before removing the securing screws.

The boiler is mounted on small wheels and can now be slid off the board and guided into the installation position.

Care should be taken not to damage any panels.

Two people are required to move the appliance from the board into the installation position.

GENERAL HANDLING GUIDELINES:

- Lift only a manageable weight, or ask for help.
- When lifting, bend the knees, and keep the back straight and feet apart.
- Do not lift and twist at the same time.
- Lift and carry items close to the body
- Wear protective clothing and gloves to protect from any sharp edges

Store the appliance in a dry area prior to installation.

THIS BOILER IS NOT SUITABLE FOR ROOF SPACE INSTALLATION.

INSTALLATION & SERVICING INSTRUCTIONS

PLEASE READ THESE INSTRUCTIONS CAREFULLY BEFORE STARTING INSTALLATION.

THESE INSTRUCTIONS ARE APPLICABLE TO THE PRODUCT MODEL(S) STATED ON THE FRONT COVER OF THIS MANUAL ONLY AND MUST NOT BE USED WITH ANY OTHER MAKE OR MODEL OF APPLIANCE.

THE INSTRUCTIONS APPLY IN THE UK/IE ONLY AND MUST BE FOLLOWED EXCEPT FOR ANY STATUTORY OBLIGATION.

THIS APPLIANCE MUST BE INSTALLED BY A COMPETENT REGISTERED ENGINEER, SUCH AS A BRITISH GAS OR OTHER CORGI REGISTERED PERSONNEL.

IF YOU ARE IN **ANY DOUBT** CONTACT THE WORCESTER TECHNICAL SUPPORT HELPLINE.

DISTANCE LEARNING AND TRAINING COURSES ARE AVAILABLE FROM WORCESTER, PART OF THE BOSCH GROUP.

PLEASE LEAVE THESE INSTRUCTIONS, THE USER GUIDE AND THE COMPLETED BENCHMARK LOG BOOK (AT THE BACK OF THIS MANUAL) OR A CERTIFICATE CONFIRMING COMPLIANCE WITH IS 813 (EIRE ONLY) WITH THE USER OR AT THE GAS METER AFTER INSTALLATION OR SERVICING.

COMMERCIAL INSTALLATION:

IF INSTALLING A GROUP OF APPLIANCES TOGETHER, ON COMMERCIAL PREMISES, THAT TOTALS MORE THAN 70KW, THEN THE APPLIANCES MUST BE INSTALLED IN ACCORDANCE WITH THE REQUIREMENTS OF IGE/UP/10 THEREFORE A COMMERCIAL GAS QUALIFICATION WILL BE REQUIRED.

ABBREVIATIONS:

Ø	Diameter
NG	Natural Gas
LPG	Liquid Petroleum Gas
CH	Central Heating
DHW	Domestic Hot Water
TRV	Thermostatic Radiator Valve
IP	Ingress Protection
RS	Room sealed flue
N/A	Not allowed
SEDBUK	Seasonal Efficiency for Domestic Boilers in the United Kingdom

SYMBOLS USED IN THIS MANUAL:



Domestic hot water



Central heating



Room thermostat



Frost thermostat



Wait time period



Programmer/timer OFF



Programmer ON CH only



Programmer ON DHW only



Programmer ON CH and DHW



Cold water main supply



Electricity supply



Fuel supply

CONTENTS

SAFETY & REGULATIONS

SAFETY PRECAUTIONS	2
INSTALLATION REGULATIONS	2

APPLIANCE INFORMATION

GENERAL INFORMATION	3
TECHNICAL DATA	4
LAYOUT & COMPONENTS	5

PRE-INSTALLATION

CLEANING PRIMARY SYSTEMS	6
MAINS SUPPLIES	7
WATER SYSTEMS & PIPEWORK	9
CONDENSATE PIPEWORK	11
PRESSURE RELIEF PIPEWORK	12
BOILER LOCATION & CLEARANCES	13
MOUNTING FRAME CONNECTIONS	14
TERMINAL OUTLET POSITIONS	17
ROOM SEALED FLUE OPTIONS	18

INSTALLATION

UNPACKING THE BOILER	19
MOUNTING FRAME FIXING / FLUE OPENING	20
MOUNTING FRAME CONNECTIONS	21
FLUE LENGTHS/FLUE MEASURING & CUTTING	22
FLUE MEASURING & CUTTING	23
FLUE INSTALLATION	25
STANDARD FLUE INSTALLATION	26
EXTENDED FLUE INSTALLATION	27
FLUE TERMINAL PLUME MANAGEMENT	28
CONDENSATE, GAS & WATER CONNECTIONS	29
PRESSURE RELIEF VALVE OUTLET	30
ELECTRICAL	31

COMMISSIONING

PRE-COMMISSIONING CHECKS	32
FILLING THE SYSTEM	33
WATER TREATMENT	34
STARTING THE APPLIANCE	35
FINISHING COMMISSIONING	36

SERVICING & SPARES

INSPECTION AND SERVICE	37
REPLACEMENT OF PARTS	41
SETTING THE GAS/AIR RATIO	46
SHORT PARTS LIST	47

CONVERSION KITS

L.P.G. CONVERSION	48
-------------------	----

FAULT FINDING & DIAGRAMS

ELECTRICAL WIRING DIAGRAM	49
CENTRAL HEATING FUNCTION	50
DHW FUNCTION	51
FAULT FINDING	52

BENCHMARK LOG BOOK AT REAR OF MANUAL

SAFETY &
REGULATIONS

APPLIANCE
INFORMATION

PRE-
INSTALLATION

INSTALLATION

COMMISSIONING

SERVICING
& SPARES

CONVERSION
KITS

FAULT FINDING
& DIAGRAMS

1

SAFETY PRECAUTIONS

IF YOU SMELL GAS:

- X** DON'T SMOKE OR STRIKE MATCHES.
- X** DON'T TURN ELECTRICAL SWITCHES ON OR OFF.
- ✓** DO PUT OUT NAKED FLAMES.
- ✓** DO OPEN DOORS AND WINDOWS.
- ✓** DO KEEP PEOPLE AWAY FROM THE AREA AFFECTED.
- ✓** DO TURN OFF THE CONTROL VALVE AT THE METER.
- ✓** DO CALL YOUR GAS COMPANY.

BOILER OPERATION:

This boiler must only be operated by a responsible adult who has been instructed in, understands and is aware of the boiler's operating conditions and effects.

BENCHMARK: *benchmark*

A Benchmark Log Book is provided, at the back of this manual, for the installer to complete including their CORGI registration number to confirm that the boiler has been installed, commissioned and serviced according to the manufacturer's instructions.

IMPORTANT: The completed Benchmark Log Book will be required in the event of any warranty work and may be required by the local Building Control Inspector.

HEALTH & SAFETY:

The appliance contains no asbestos and no substances have been used in the construction process that contravene the COSHH Regulations (Control of Substances Hazardous to Health Regulations 1988). Where applicable, the CE mark indicates compliance with relative EU Directives.

COMBUSTIBLE AND CORROSIVE MATERIALS:

Do not store or use any combustible materials (paper, thinners, paints etc.) inside or within the vicinity of the appliance.

The combustion air must be kept clear of chemically aggressive substances, which can corrode the appliance and invalidate any warranty.

FITTING & MODIFICATIONS:

Fitting the appliance and any controls to the appliance may only be carried out by a competent engineer in accordance with these instructions and the relevant Installation Regulations.

Flue systems must not be modified in any way other than as described in the fitting instructions.

Any misuse or unauthorised modifications to the appliance, flue or associated components and systems could invalidate the warranty. The manufacturer accepts no liability arising from any such actions, excluding statutory rights.

SERVICING:

Advise the user to have the system regularly serviced by a competent, qualified engineer (such as British Gas or other CORGI registered personnel) using approved spares, to help maintain the economy, safety and reliability of the appliance.

IMPORTANT - The service engineer must complete the Service Record in the Benchmark Log Book after each service.

INSTALLATION REGULATIONS

Failure to install appliances correctly could lead to prosecution.

This appliance must be installed by a competent registered engineer, such as British Gas or other CORGI registered personnel, in accordance with, and comply to, the current: Gas Safety (Installation & Use) Regulations 1998, IEE Regulations, Building Regulations, Building Standards (Scotland) (Consolidation), Building Regulations (Northern Ireland), local water by-laws, Health & Safety Document 635 (The Electricity at Work Regulations 1989), IS 813 (Eire) and any other local requirements.

The relevant Standards should be followed, including:

BS7074:1 : Code of practice for domestic heating and hot water supply

BS6891 : Installation of low pressure gas pipework up to 32mm (R1_{1/4})

BS EN:12828 : Central heating for domestic premises

BS5440:1 : Flues and ventilation for gas appliances of rated heating not exceeding 70kW (net) : Flues

BS5440:2 : Flues and ventilation for gas appliances of rated heating not exceeding 70kW (net) : Air Supply

BS7593 : Treatment of water in domestic hot water central heating systems

BS6798 : Installation of gas fired boilers of rated input up to 70kW (net)

Where no specific instruction is given, reference should be made to the relevant codes of Practice.

L.P.G. Installation:

An appliance using L.P.G. must not be installed in a room or internal space below ground level unless one side of the building is open to the ground.

Timber framed buildings:

Where the boiler is to be fitted to a timber framed building the guidelines laid down in BS5440: Part 1 and IGE "Gas Installations in Timber Frame Buildings" should be adhered to.

IMPORTANT:

Artificially softened water must not be used to fill the central heating system.

GENERAL INFORMATION

STANDARD PACKAGE:

- A - Floor standing gas fired combination boiler for central heating and domestic hot water.
- B - Mounting frame complete with pre-plumbing manifold assembly.
- C - Literature pack.
- D - Condensate waste pipe & non-return valve

SPECIFICATIONS:

- Pre-wired and pre-plumbed.
- Galvanised steel inner frame.
- Bosch Heatronic control system.
- Automatic ignition.
- Direct burner ignition electrodes.
- Built-in frost thermostat.
- Built-in fault finding diagnostics.
- Modulating automatic gas valve.
- Combustion air fan with speed regulator.
- CH temperature sensor & control.
- DHW flow sensor & temperature control.
- Integral water circulating pump with anti-seizure protection.
- Sealed primary system & pressure gauge display.
- Pressure relief valve.
- Flue gas temperature limiter.
- Plate-type DHW heat exchanger.
- Condensate trap & pump.

APPLIANCE
INFORMATION

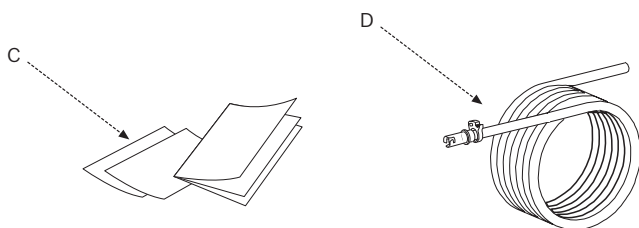
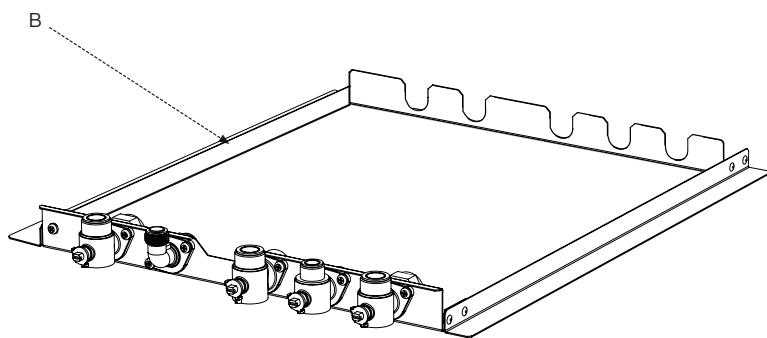
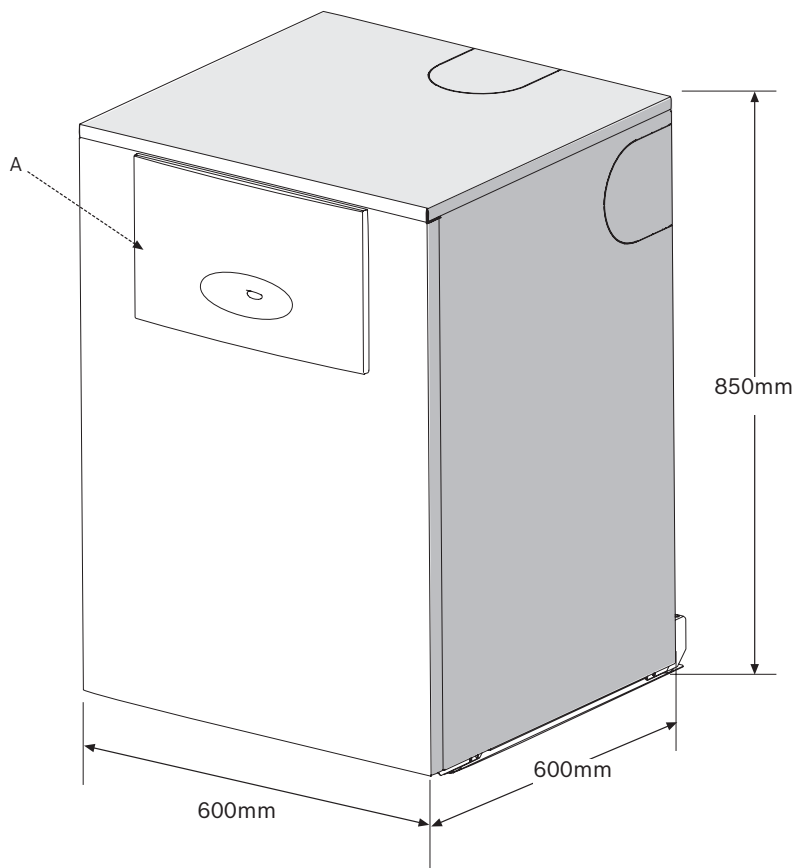

TECHNICAL DATA

APPLIANCE INFORMATION

DESCRIPTION	UNITS	Natural Gas		L.P.G	
		440CDi	550CDi	440CDi	550CDi
Central Heating					
Max. rated heat output net 40/30°C	kW	31.2	32.8	31.2	32.8
Max. rated heat output net 50/30°C	kW	30.9	32.5	30.9	32.5
Max. rated heat output net 80/60°C	kW	29.2	30.6	29.2	30.6
Max. rated heat input net	kW	29.6	31	29.6	31
Min. rated heat output net 40/30°C	kW	8.4	11	11.6	13.4
Min. rated heat output net 50/30°C	kW	8.3	10.9	11.4	13.2
Min. rated heat output net 80/60°C	kW	7.4	9.7	10.5	12.1
Min. rated heat input net	kW	7.6	10	10.8	12.5
Max. flow temperature	°C	88	88	88	88
Max. permissible operating pressure	bar	2.5	2.5	2.5	2.5
Domestic Hot Water					
Max. rated heat input net	kW	29.6	41.5	29.5	41.5
Max. rated heat output	kW	29.5	41.1	29.2	41.1
Minimum flow rate to start	l/min	2.3	2.8	2.3	2.8
Minimum pressure for max flow rate 20 l/min (±15%)	bar	1.5	-	1.5	-
Minimum pressure for max flow rate 25 l/min (±15%)	bar	-	1.7	-	1.7
Gas flow rate - Max. 10 minutes from lighting					
Natural Gas G20	m ³ /h	3.1	4.4	-	-
Propane Gas (LPG)	kg/h	-	-	2.3	3.2
Gas supply pressure					
Natural Gas G20	mb	20	20	-	-
LPG (Propane) Gas G31	mb	-	-	37	37
Flue					
Flue Gas Temp. 80/60°C, rated min. load	°C	67/55	67/55	67/55	67/55
Flue Gas Temp. 40/30°C, rated min. load	°C	43/32	43/32	43/32	43/32
CO ₂ level at max. rated heat output	%	9.4	9.4	10.8	10.8
CO ₂ level at min. rated heat output	%	8.6	9.0	10.4	10.4
NO _x - classification	class	5	5	5	5
Condensate					
Max. condensation rate	l/h	2.7	3.7	2.7	3.7
pH value, approx.		4.8	4.8	4.8	4.8
Electrical					
Electrical power supply voltage	AC...V	230	230	230	230
Frequency	Hz	50	50	50	50
Max. power consumption	W	164	206	164	206
Expansion Vessel					
Charge Pressure	bar	0.75	0.75	0.75	0.75
Total Capacity	ltr	12	12	12	12
General Data					
SEDBUK (Band A)	%	90.8	90.8	92.2	92.2
Appliance protection rating	IP	x4D	x4D	x4D	x4D
Appliance protection rating (with mechanical timer fitted into fascia)	IP	20	20	20	20
Permissible ambient temperatures	°C	0 - 50	0 - 50	0 - 50	0 - 50
Nominal capacity of appliance	ltr	51	51	51	51
Noise output level (at maximum CH output)	dB(A)	37	37	37	37
Weight (excluding packaging)	kg	112	112	112	112

LAYOUT & COMPONENTS

The diagram opposite shows the controls in the servicing position and excludes the outer case, inner covers and wiring.

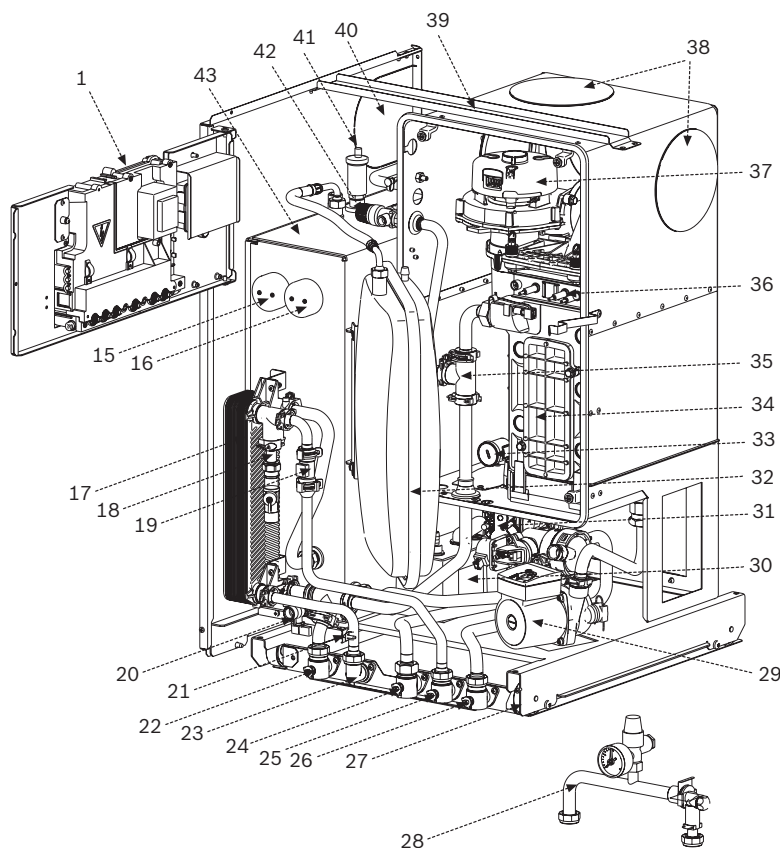
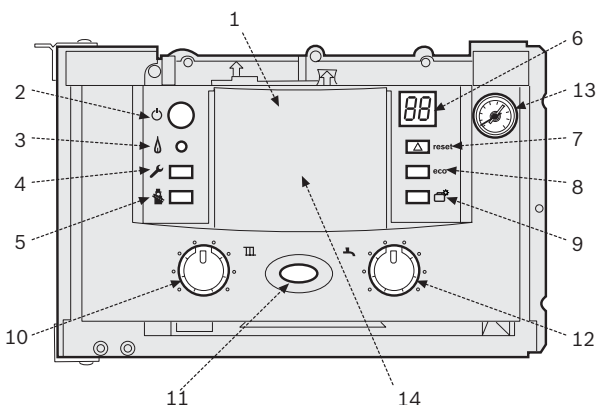
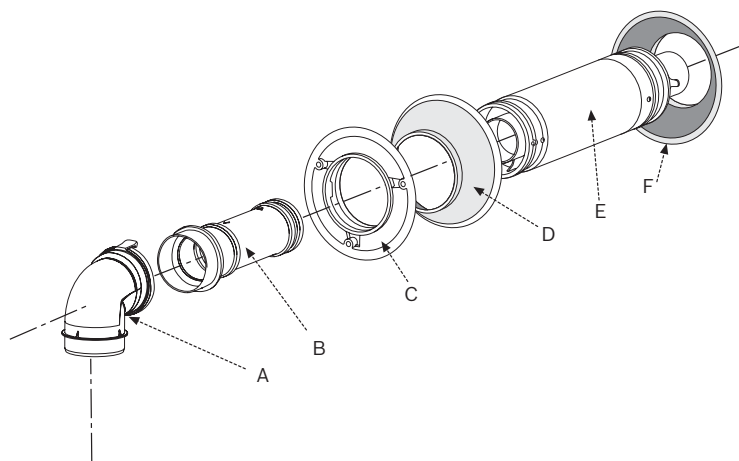

- 1 CONTROL PANEL
- 2 MASTER SWITCH FOR ON/OFF
- 3 BURNER ON INDICATOR LIGHT (GREEN)
- 4 SERVICE BUTTON
- 5 CENTRAL HEATING BOOST BUTTON
- 6 DISPLAY
- 7 RESET BUTTON
- 8 ECO BUTTON
- 9 NOT USED
- 10 CH TEMPERATURE CONTROL
- 11 MAINS ON/OFF INDICATOR & FAULT DIAGNOSTIC LIGHT
- 12 DHW TEMPERATURE CONTROL
- 13 SYSTEM PRESSURE GAUGE
- 14 POSITION FOR OPTIONAL PROGRAMMER
- 15 TANK TEMPERATURE SENSOR
- 16 TANK OVERHEAT THERMOSTAT
- 17 DHW HEAT EXCHANGER
- 18 FILLING LOOP ISOLATION VALVE
- 19 WATER FLOW SENSOR TURBINE
- 20 BOILER/TANK DRAIN & CONNECTION POINT FOR FILLING LOOP
- 21 DHW FLOW SENSOR
- 22 CH FLOW ISOLATION VALVE
- 23 DHW OUTLET
- 24 GAS ISOLATION VALVE
- 25 MAINS WATER INLET ISOLATION VALVE
- 26 CH RETURN ISOLATION VALVE
- 27 RUNNER WHEEL ON MOUNTING FRAME
- 28 OPTIONAL FILLING LINK WITH PRESSURE GAUGE: PART NO: 7 716 192 599
- 29 CIRCULATING PUMP
- 30 CONDENSATE PUMP ASSEMBLY
- 31 GAS VALVE
- 32 EXPANSION VESSEL
- 33 AIR/GAS ADJUSTMENT SCREW (SEALED)
- 34 HEAT CELL
- 35
- 36 GAS BURNER/SPARK ELECTRODES
- 37 COMBUSTION AIR MODULATING FAN
- 38 FLUE BLANKING PLATES
- 39 CASING SUPPORT STRUT
- 40 CASE 'KNOCK-OUT' PANEL-FLUE
- 41 AUTO AIR VENT
- 42 SYSTEM PRESSURE RELIEF VALVE
- 43 HEAT STORE

100mmØ HORIZONTAL FLUE COMPONENTS (Kit Part No. 7 716 191 155)

- A - 93° ELBOW
- B - ADAPTOR
- C - CONNECTOR
- D - INNER WALL FLUE COLLAR
- E - TELESCOPIC TERMINAL ASSEMBLY
- F - OUTER WALL FLUE COLLAR

FLUE KITS:
 Vertical 100mmØ Part No. 7 716 191 156
 Vertical 125mmØ Part No. 7 716 191 158
 Horizontal 125mmØ Part No. 7 716 191 157

IMPORTANT: All the following pre-installation sections must be read and requirements met before starting boiler or flue installation.

CAUTION: ISOLATE THE MAINS SUPPLIES BEFORE STARTING ANY WORK AND OBSERVE ALL RELEVANT SAFETY PRECAUTIONS.

CLEANING PRIMARY SYSTEMS

IMPORTANT:

Debris from the system can damage the boiler and reduce efficiency. Failure to comply with the guidelines for the use of water treatment with the appliance will invalidate the appliance warranty.

BEFORE CLEANING THE SYSTEM:

ENSURE THE SYSTEM AND PIPEWORK ARE IN GOOD WORKING ORDER.

USE THE EXISTING BOILER/CIRCULATING PUMP WHERE POSSIBLE OR USE A POWER FLUSHING MACHINE TO AID THE CLEANSING PROCEDURE BEFORE INSTALLING A NEW BOILER.

CLEANING THE PRIMARY SYSTEM:

- ▶ Fill the system with cold mains water to the recommended pressure and check for leaks.
- ▶ Open all drain cocks and drain the system.
- ▶ Close drain cocks and add a suitable flushing agent at the correct strength for the system condition in accordance with the manufacturer's instructions.
- ▶ Circulate the flushing agent before the boiler is fired up.
- ▶ Run the boiler and system at normal operating temperature in accordance with the manufacturer's instructions.
- ▶ Drain and thoroughly flush the system to remove the flushing agent and any debris.

MAINS SUPPLIES



ELECTRICAL SUPPLY:

- Supply: 230V - 50Hz.
- Cable: PVC insulated 0.75mm² (24 x 0.2mm) temperature rated to 90°C.
- External 3A fuse to BS1362.
- The appliance must be earthed.
- It must be possible to isolate the appliance from the electric supply with at least a 3mm contact separation in both poles supplying the appliance.
- Wiring between the appliance and the electrical supply must comply with IEE wiring regulations and any local regulations which may apply for fixed wiring to a stationary appliance.
- Any system connected to the boiler must not have a separate electricity supply.



WATER SUPPLY:

- Connections to the water supply must not be made without the authority of the local water company.
- The appliance cold water supply should be the first connection off the water main where possible.

Water Mains Pressure:

- Minimum dynamic mains water pressure 1.2 bar for maximum performance.
- Maximum mains fed water pressure 10 bar. If necessary, fit a pressure reducing valve.

IMPORTANT: Non-return, back flow prevention devices (including those associated with water meters) fitted to the mains water supply can cause a pressure build up which could damage the boiler and other household appliances.

- Where the water main supply has a non-return, back flow prevention valve fitted, a mini expansion vessel (A) should be connected to the mains water inlet pipe (B) between the non-return valve (C) and the boiler (D) as shown opposite.

Use in hard water areas:

Normally there is no need for water treatment to prevent scale formation as the maximum temperature of the heat exchanger is limited by the electronic control circuit.

In areas where the temporary water hardness exceeds 200ppm, consideration may need to be given to the fitting of a scale prevention device. In such circumstances, the advice of the local water authority should be sought.

MAINS WATER EXPANSION VESSEL:

- A - Mini expansion vessel, part No. 7 716 192 105
- B - Water Main supply pipe
- C - Non-return valve
- D - Boiler

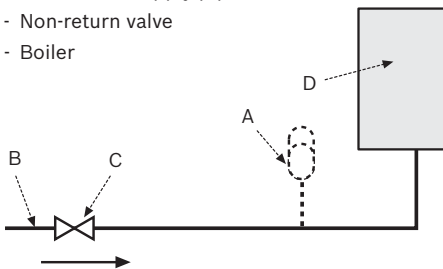

MAINS SUPPLIES



GAS SUPPLY:

- Boilers using NG must be connected to a governed meter.
- LPG boilers must be connected to a regulator.
- Installation and connection of the gas supply to the boiler must be in accordance with BS6891.
- Under no circumstances should the diameter of the gas supply pipe be less than that of the appliance inlet connection.
- The meter or regulator and pipework to the boiler must be checked, preferably by the gas supplier to ensure it is in good working order and can meet the gas flow and pressure requirements in addition to the demand from any other appliance being served.

PRIMARY SYSTEM PLASTIC PIPEWORK:

- Any plastic pipework must have a polymeric barrier with 600mm (minimum) length of copper connected to the boiler.
- Plastic pipework used for underfloor heating must be correctly controlled with a thermostatic blending valve limiting the temperature of the circuits to approx. 50°C. The pipework from the boiler to the blending valve must be in copper.

PRIMARY SYSTEM/CONNECTIONS/VALVES:

- **Do not use galvanised pipes or radiators.**
- All system connections, taps and mixing valves must be capable of sustaining a pressure of 3 bar.
- Radiator valves should conform to BS2767:10.
- All other valves should conform to BS1010.
- On new installations TRV's must be used on all radiators except the radiator where the room thermostat is sited, this must be fitted with lockshield valves and left open. All installations should have TRV's fitted to radiators within the sleeping accommodation.
- Drain cocks are required at all the lowest points on the system.
- Air vents are required at all high points on the system.

PRE-INSTALLATION

TYPICAL SEALED SYSTEM:

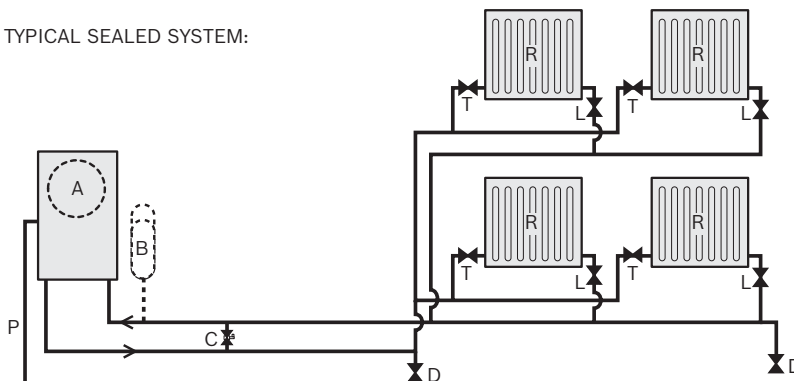

- A - Appliance expansion vessel
- B - Extra expansion vessel
- C - Automatic bypass valve
- D - Drain cock
- L - Lockshield valve
- P - Pressure relief discharge
- R - Radiators
- T - TRV

SEALED PRIMARY SYSTEM:

- Where the system volume is more than 100 litres or exceeds 2.5bar at maximum heating temperature an extra expansion vessel (B) must be fitted as close as possible to the appliance in the central heating return.
- Pressurise the extra expansion vessel (B) to the same figure as the expansion vessel built into the appliance - REFER TO TECHNICAL DATA TABLE.

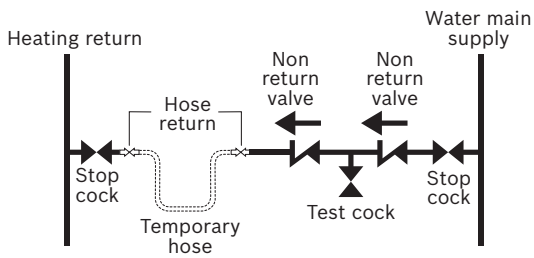

FILLING PRIMARY SYSTEMS:

- The CH sealed system must be filled using a WRAS approved filling loop or comply with the diagram opposite for system fill.
- The filling point must be at low level and must never be a permanent direct fixing to the mains water supply.

SHOWERS/BIDETS:

- If a shower head can be immersed in water or comes closer than 25mm from the top edge of a bath or shower tray spill over level then an anti-siphon device must be fitted to the shower hose.
- Bidets with direct hot & cold mains water can be used (with the approval of the local water authority) and must be the over rim flushing type with shrouded outlets to prevent the fitting of hand held sprays.

DOMESTIC HOT WATER:

- Taps and mixing valves must be capable of sustaining a pressure up to 10 bar.
- Hot water temperature and flow rate are affected by the size and insulation of pipework making up the distribution system and are controlled by the hot water tap and the water main inlet pressure. A mixing valve can be fitted if a more permanent setting is required.
- If using more than one outlet at once causes water flow starvation, fit flow balancing valves or Ball-O-Fix valves to the appropriate outlets.

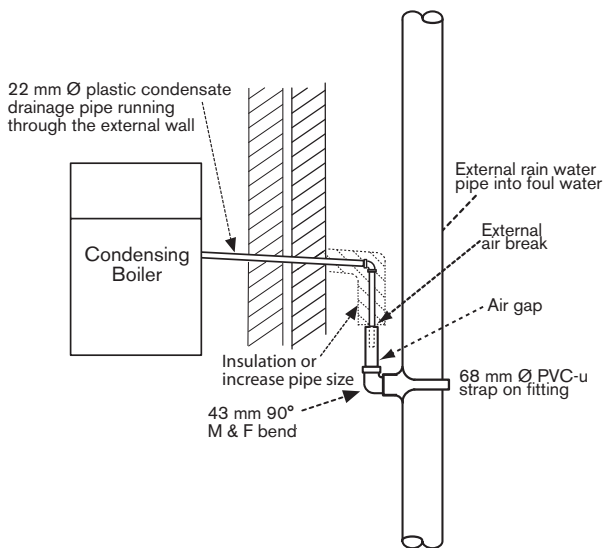
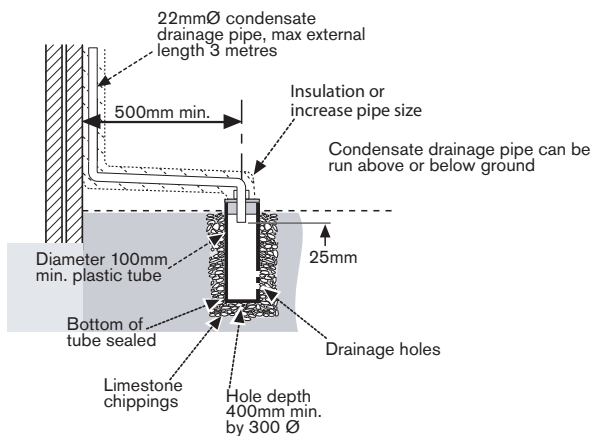
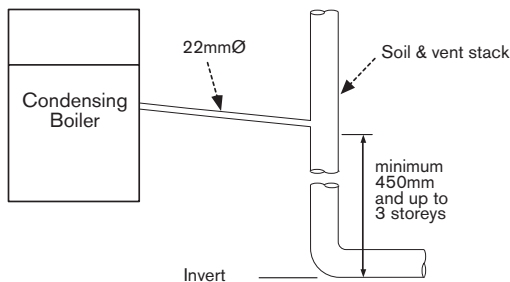
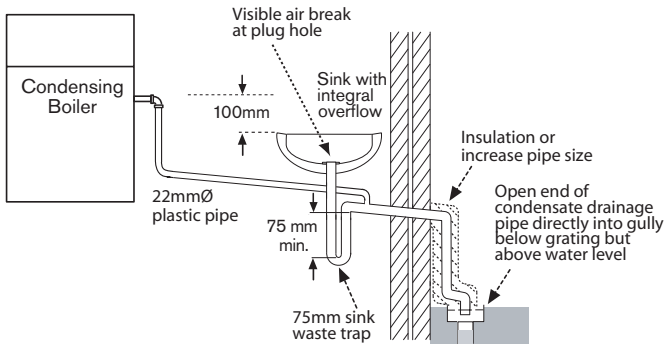

IMPORTANT:

- Ensure there are no blockages in the pipe run
- Care should be taken when siting a soak-away to avoid obstructing existing services
- Condensate waste must not be terminated into a septic tank or cesspit

CONDENSATE PIPEWORK:

- The condensate pipe must be a minimum of 22mm Ø plastic pipe.
- The condensate pipework must fall at least 50 mm per metre towards the outlet and should take the shortest practicable route.
- The pipework must follow one of the options shown opposite or discharge directly into a vent stack min. 450mm above pipe invert or into a gully below ground but above the water level.
- Wherever possible the condensate discharge pipe work should be routed and terminated internally. Should this not be possible, and the only available route is external, the following conditions should be observed:

External pipe work

- Pipe work length should be kept to a minimum and the route as vertical as possible.
 - Where pipe work is subjected to extreme cold or wind chill, a weather proof insulation should be used.
- Alternatively the condensate pipework could be increased to a minimum diameter of 32mm without the requirement to insulate.

Condensate soakaway

The condensate drainage pipe may be run above or below the ground to the soakaway. The example shown opposite runs above ground level. The soakaway must use a 100mm diameter plastic tube with two rows of three 12mm holes on 25mm centres and 50mm from the bottom of the tube. The holes must face away from the house. The tube must be surrounded by at least 100mm of limestone chippings to a depth of 400mm.

Fitting an external air break

Use the situation opposite when a rain water down pipe is used to dispose of condensate and the down pipe goes directly into an existing sewer that carries both rainwater and foul water. An air break must be installed in the 32/43mm pipework, between the boiler condensate outlet and the drainpipe, outside the property, to avoid flooding during adverse weather conditions.

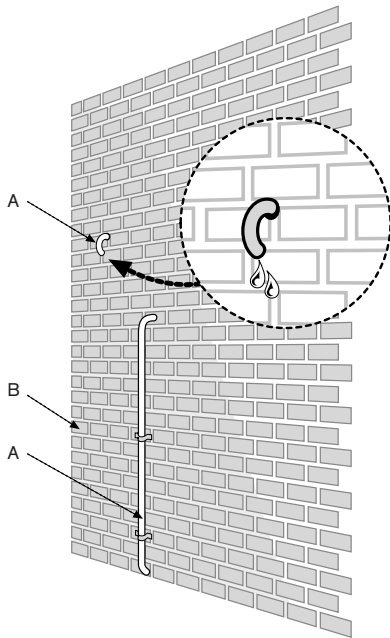

PRESSURE RELIEF PIPEWORK

IMPORTANT: Debris from the system can damage the boiler and reduce efficiency. Failure to comply with the guidelines for the use of water treatment with the appliance will invalidate the appliance warranty.

- The pressure relief drain pipe (A) should be at least 15mm diameter copper pipe and run downwards away from the boiler and discharge away from any electrics or other hazard, preferably to an external drain or soakaway.
- Pipe (A) should be finished with a partial bend, near the outlet to face the external wall(as shown) to help prevent freezing.

- A - Drain pipe.
B - Outside wall.

1: INSTALLATION CLEARANCES

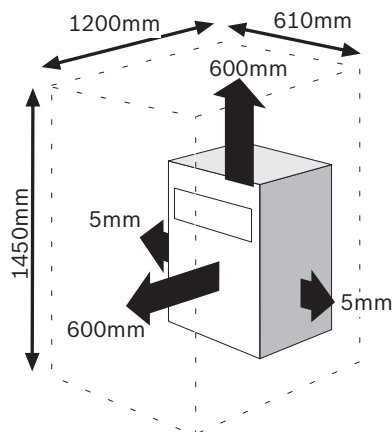

2: SERVICE / VENTED CUPBOARD CLEARANCES

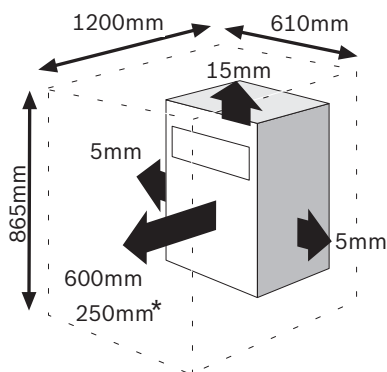

3: UNVENTED COMPARTMENT CLEARANCES

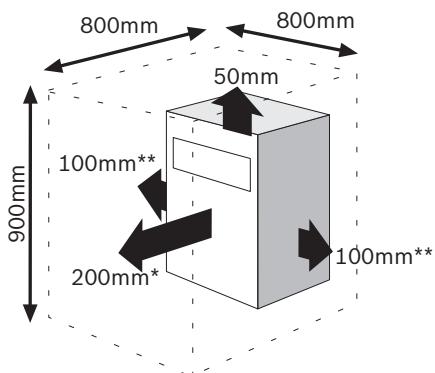

BOILER LOCATION & CLEARANCES

- This boiler is only suitable for installing internally within a property at a suitable location onto a fixed rigid non-combustible surface at least the same size as the boiler and capable of supporting the boiler weight.
- The boiler is not suitable for external installation unless a suitable enclosure is provided.
- THIS BOILER IS NOT SUITABLE FOR ROOF SPACE INSTALLATION.

COMMERCIAL INSTALLATION:

- If installing more than one appliance in a modular or cascade arrangement in a commercial premises, that total more than 70kW, then additional ventilation is needed to comply with the Dangerous Substances and Explosive Atmospheres Regulations (DSEAR).

Compartments:

Follow the requirements of BS6798 and BS5440 Part 2 and note:

- Minimum clearances must be maintained.
- An access door is required to install, service and maintain the boiler and any ancillary equipment.
- If fitting the boiler into an airing cupboard use a non-combustible perforated material (maximum hole sizes of 13mm) to separate the boiler from the airing space.

1: INSTALLATION CLEARANCES:

Diagram '1' shows the minimum space required to install the boiler only.

2: SERVICE CLEARANCES:

Diagram '2' opposite shows the minimum space required to service the boiler only. 25mm to an removable door.

3: UNVENTED COMPARTMENT CLEARANCES:

Diagram '3' shows the minimum space required to install and service the boiler inside an unvented compartment.

*Space required for unvented areas with a removable door or panel.

This space can be reduced to 50mm for **one side only as long as both the side clearances add up to the total of both the side measurements shown or more.

5: VENTING COMPARTMENTS

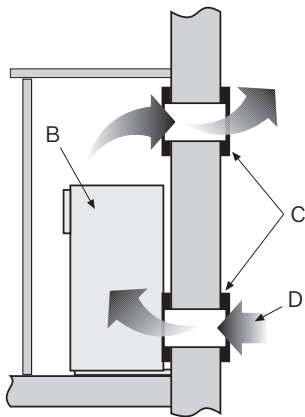

4: AIRING CUPBOARD CLEARANCES

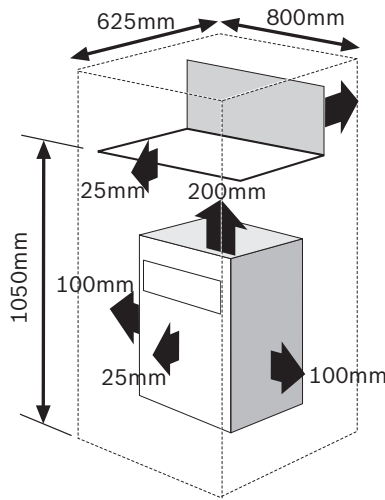

BOILER LOCATION & CLEARANCES

4: AIRING CUPBOARD CLEARANCES:

Diagram 'd' opposite shows the minimum space required to install and service the boiler within an airing cupboard.

5: VENTING COMPARTMENTS:

If the clearances are less than those stated for options '3' & '4' (above) then ventilation must be provided as described in BS 5440.

A minimum of 2 air vents (C) of equal size must be fitted, one at low level and another at high level on the same wall using the same air for circulation.

Minimum free area required for venting:

For area directly from outside:

440CDi 155cm² per vent.

550CDi 220cm² per vent.

For air from internal space/room:

440CDi 310cm² per vent.

550CDi 440cm² per vent.

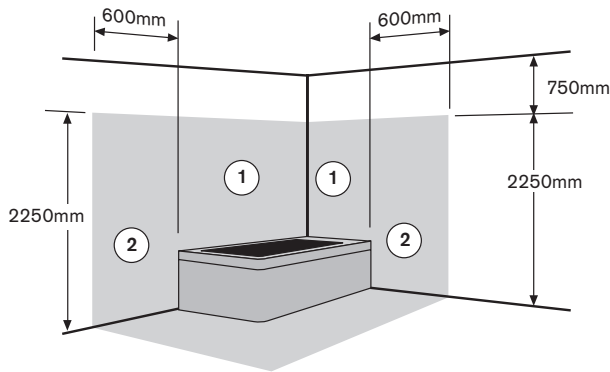

6: BATHROOMS:

IMPORTANT:

Any switch or appliance control using mains electricity must not be within reach of a person using the bath or shower.

Electrical switches, fused spurs and socket outlets must not be situated in the bathroom.

A boiler fitted with a non-mechanical timer or with no timer can be installed in zone 2 or outside the shaded area.

A boiler with a mechanical timer or RF mechanical timer with a room thermostat must only be installed outside the shaded area.

Additional RCD (Residual Current Device) protection may be required.

Refer to the latest IEE wiring regulations.

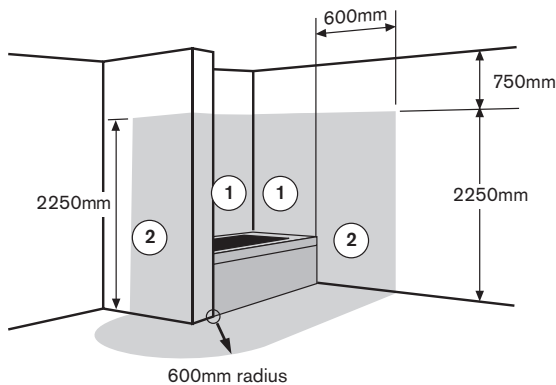

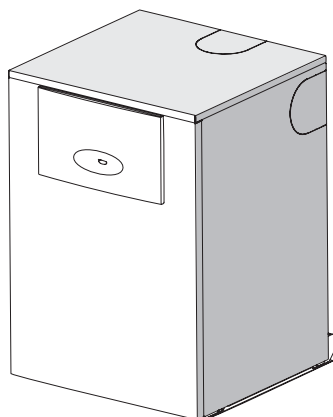

MOUNTING FRAME CONNECTIONS

CONNECTIONS:

Water: 22mm compression fittings

Gas: 22mm compression fitting.

PRE-PLUMBING:

- With the mounting frame (A) installed, pipework can be connected to the valves on the plumbing manifold.
- The system can be filled (without the boiler being connected) using an optional charging link assembly (B).
- The valves can be closed enabling the DHW and CH systems to be tested.
- The boiler can be installed at a later date.

RUNNING PIPES BEHIND THE BOILER:

- The frame should sit against the wall (not the skirting board) with enough room for the pipework.
- Do not cross a pipe over another.
- The area around a rear flue outlet must be avoided.

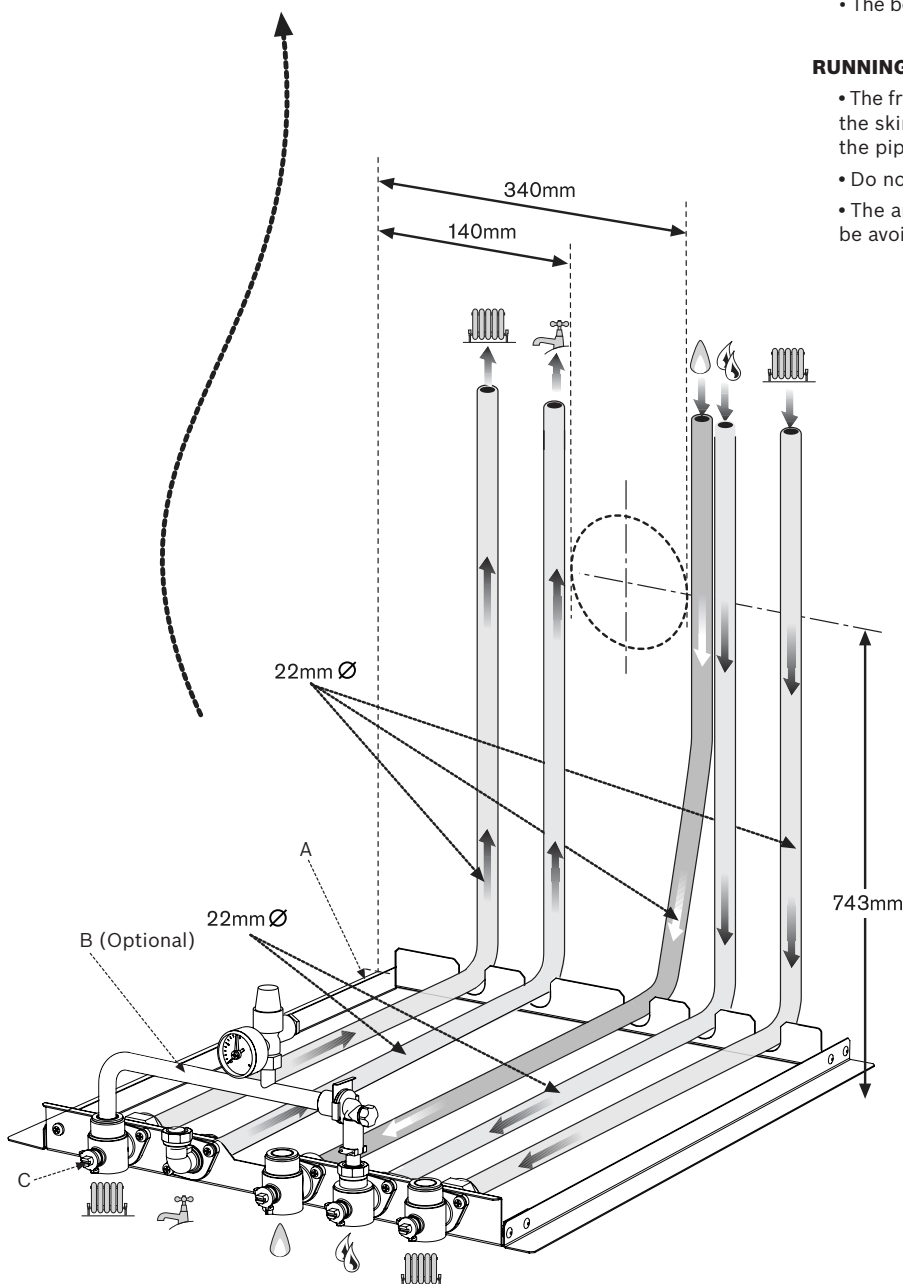

PRE-
INSTALLATION

- The flue must be fitted and terminated in accordance with the recommendations of BS5440 : Part 1.
- The flue must not cause an obstruction.
- Discharge and any noise from the flue outlet must not cause a nuisance.
- Flue gases have a tendency to plume and in certain weather conditions a white plume of condensation will be discharged from the flue outlet. Where this could be a nuisance, for example, near security lighting, an alternate position should be found.
- The air inlet/outlet duct and the terminal of the boiler must not be closer than 25mm to any combustible material. Detailed recommendations on protection of combustible materials are given in BS 5440: Part 1
- A protective terminal guard must be fitted if the terminal is 2m or less above a surface to which people have access. The guard must be spaced equally (minimum 50 mm) around the flue and fixed to the wall with plated screws. See Contact Information (inside front cover).

NOTE: All measurements are the minimum clearances required. Terminals must be positioned so to avoid combustion products entering the building.

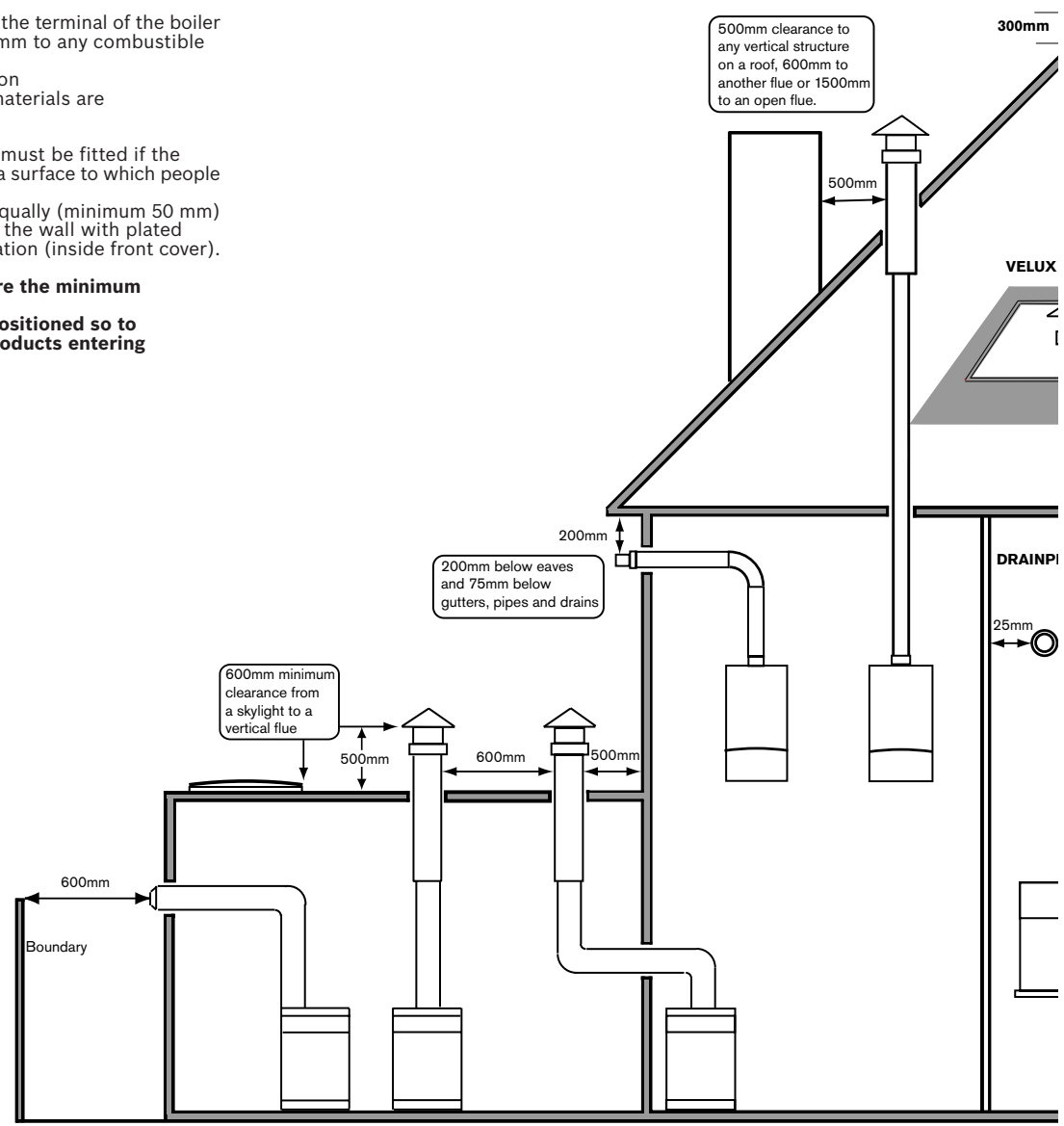

600mm distance to a boundary, unless it will cause a nuisance. BS 5440: Part 1 recommends that care is taken when siting terminals in relation to boundaries

Deduct one metre off the total flue length for every 45° bend used
Deduct two metres off the total flue length for every 90° bend used

The flue turret has a built-in angle of 3° to ensure that the condensate flows back to the boiler for safe disposal via the condensate waste pipe.
All horizontal flue sections must rise by 3° or at least 52mm for each metre away from the boiler to ensure condensate flows back into the boiler.

Vertical flue clearance 500mm to non-combustible building material, and 1500mm clearance to combustible building material

TERMINAL OUTLET POSITIONS

NOTES:

Plume management kits are available for 100mm horizontally terminated flues. Please refer to the installation instructions supplied with the plume management kits.

If plume redirection is utilised, the clearance from any opening must be increased in the direction of the plume to 1500mm.

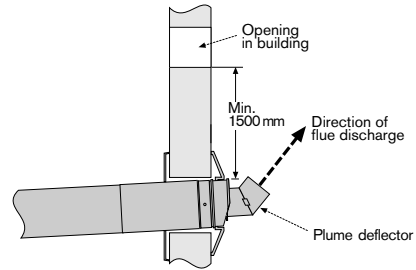
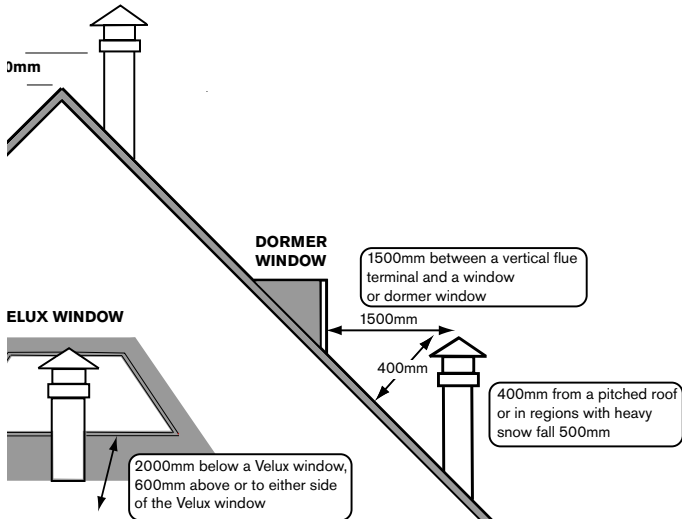

PRE-INSTALLATION

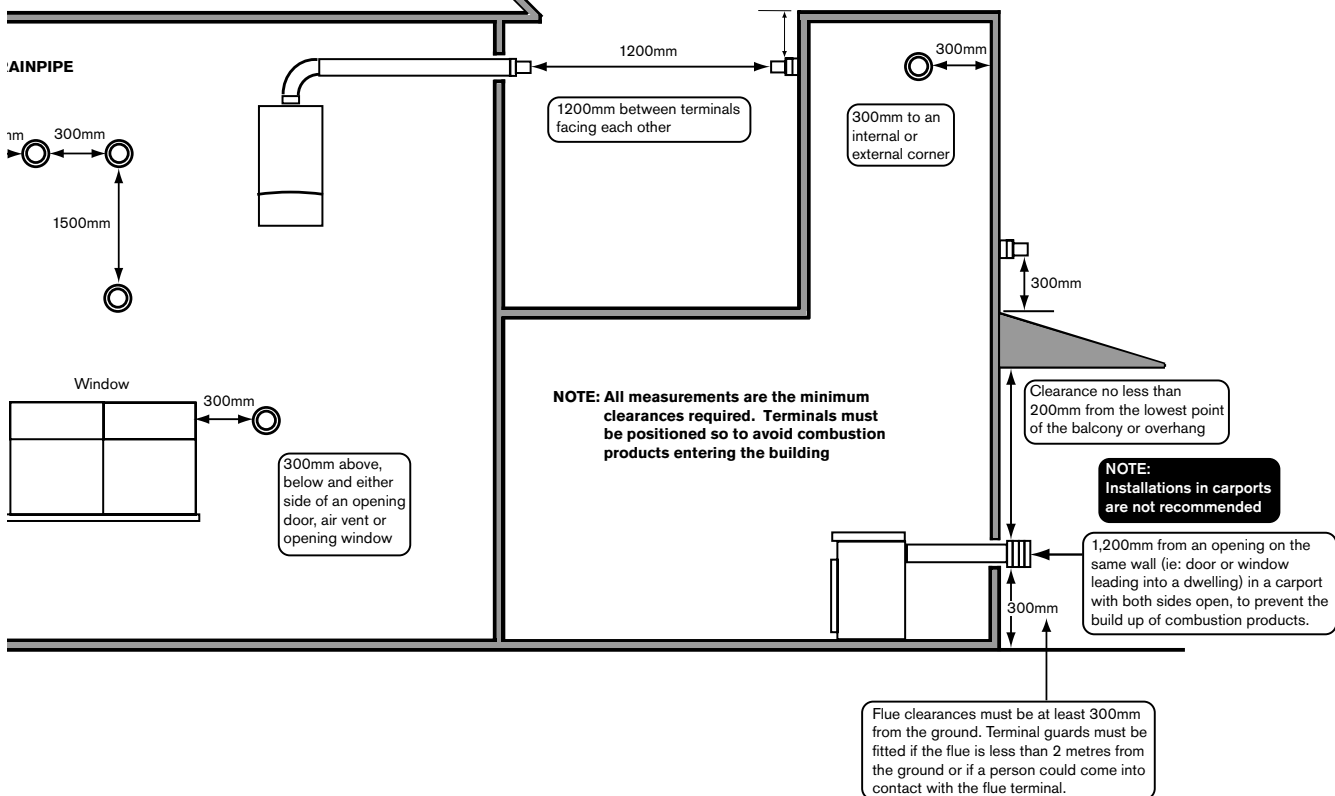

8 716 115 089a

L= Ø100mm 140 - 530mm
L= Ø125mm 350 - 1200mm

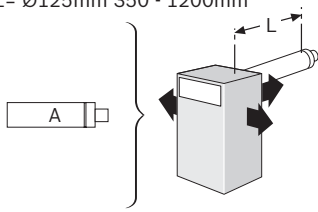

L= Ø125mm 9000mm

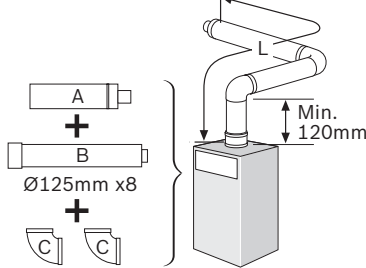

L= Ø100mm 310 - 4000mm
L= Ø125mm 350 - 13000mm

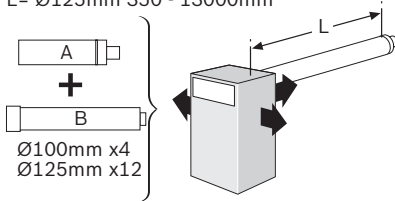

L= Ø125mm 7000mm

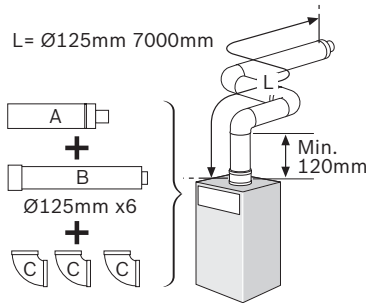

L= Ø100mm 2000mm
L= Ø125mm 11000mm

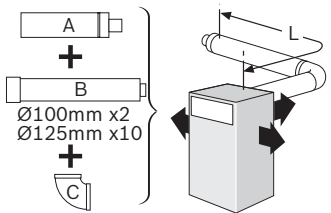

L= Ø100mm 4400mm
L= Ø125mm 13000mm

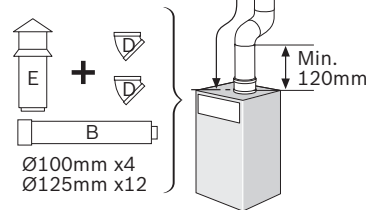

L= Ø100mm 2000mm
L= Ø125mm 11000mm

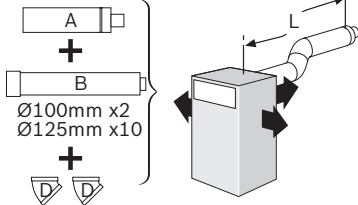

L= Ø100mm 2400mm
L= Ø125mm 11000mm

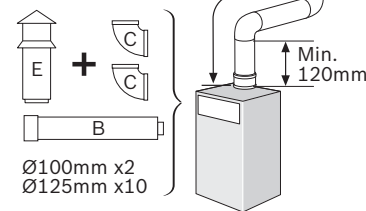

ROOM SEALED FLUE OPTIONS

The diagrams (opposite) show the components used and the maximum flue length for each configuration of Ø100mm and Ø125mm flues.

- Only straight flue sections can be reduced in length by cutting.
- The Ø100mm horizontal flue terminal can be fitted from inside or outside the building.

IMPORTANT:

All horizontal sections must rise away from the boiler by 52mm per metre (3°) to allow the condensate to drain back to the boiler.



- A - Horizontal terminal
- B - Straight flue extension
- C - Flue bend 90°
- D - Flue bend 45°
- E - Vertical Terminal

Calculating the flue length:

Measure the total flue length (L) required, noting that the maximum straight flue length including the terminal is:

Horizontal Ø60/100mm: 4000mm

Horizontal Ø80/125mm: 13000mm

Vertical Ø60/100mm: 6400mm

Vertical Ø80/125mm: 15000mm

Then reduce the total straight flue length for each extra flue bend (excluding the flue elbow) by:

2000mm for 90°

1000mm for 45°

Flue Extension lengths:

Horizontal & Vertical Ø60/100mm: 950mm

Horizontal & Vertical Ø80/125mm: 950mm

Flue Terminal lengths:

Horizontal Ø60/100mm: 530mm

Horizontal Ø80/125mm: 1200mm

Vertical Ø60/100mm: 1140mm

Vertical Ø80/125mm: 1365mm

IMPORTANT: All the previous Pre-Installation sections must be read and requirements met before starting boiler or flue installation.

UNPACKING THE BOILER

Take care not to damage the boiler panels or the floor and note that the boiler may contain some water due to factory testing.

Unpacking:

- 1 ▶ Undo the ties securing the carton to the pallet
If a sharp implement is used, care must be taken not to pierce the carton or cause injury.
- 2 ▶ Before removing the carton it is advised that the top flaps are opened and the ancillary items (A, B, C & D) are removed and set to one side.
- 3 ▶ The carton can now be lifted off the boiler.
 - ▶ Remove the plastic bag protecting the boiler surfaces and place safely away from the working area.
 - ▶ Remove 2 screws at the rear of the board securing the board to the pallet.
 - ▶ Slide the boiler and board off the pallet.
- 4 ▶ Grip the outer sides of the front panel pull and lift away from retaining lugs.
 - ▶ Remove securing screw, at the front of the boiler, from the pallet.
 - ▶ Remove remaining screws, at the rear of the boiler, from the pallet.
 - ▶ The boiler is mounted on small wheels and two people are recommended to move the boiler from the board taking care not to damage the panels or the floor.
- 5 ▶ Remove the rubber plug (E) from the boiler pipework by pulling down.

At all times the correct method for handling heavy objects should be strictly observed.

GENERAL HANDLING GUIDELINES:

- ▶ Lift only a manageable weight, or ask for help.
- ▶ When lifting, bend the knees, and keep the back straight and feet apart.
- ▶ Do not lift and twist at the same time.
- ▶ Lift and carry items close to the body
- ▶ Wear protective clothing and gloves to protect from any sharp edges

THIS BOILER IS NOT SUITABLE FOR ROOF SPACE INSTALLATION.

- A - Mounting frame
- B - Installation pack
- C - Literature pack
- D - Condensate waste pipe & non-return valve

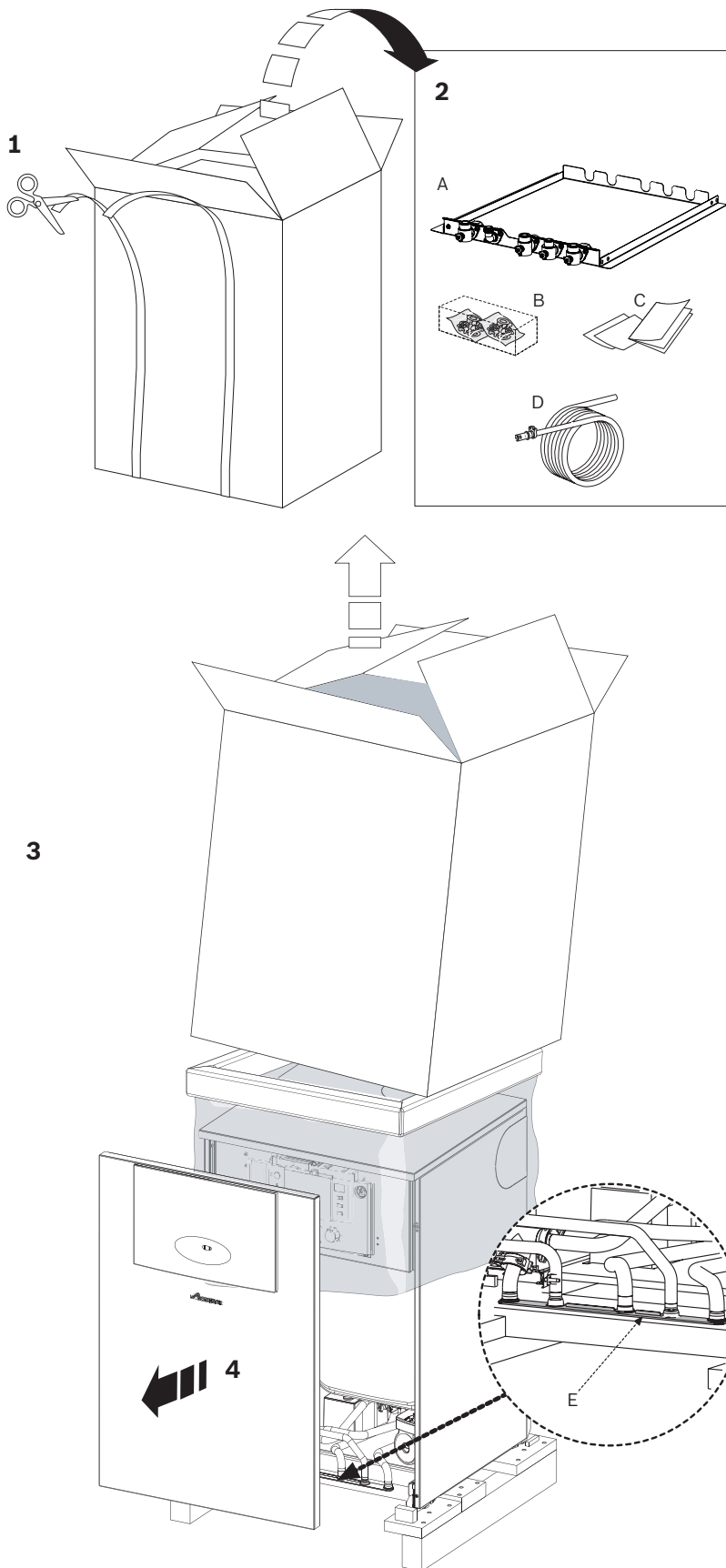

All dimensions in mm

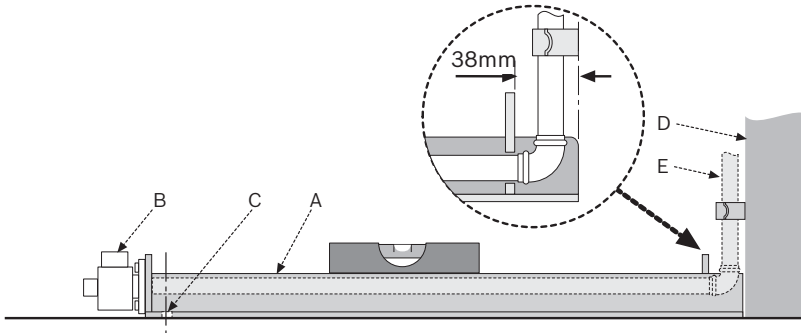
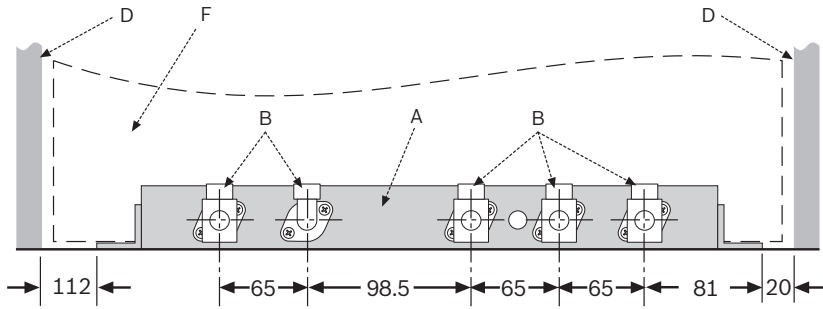

INSTALLATION

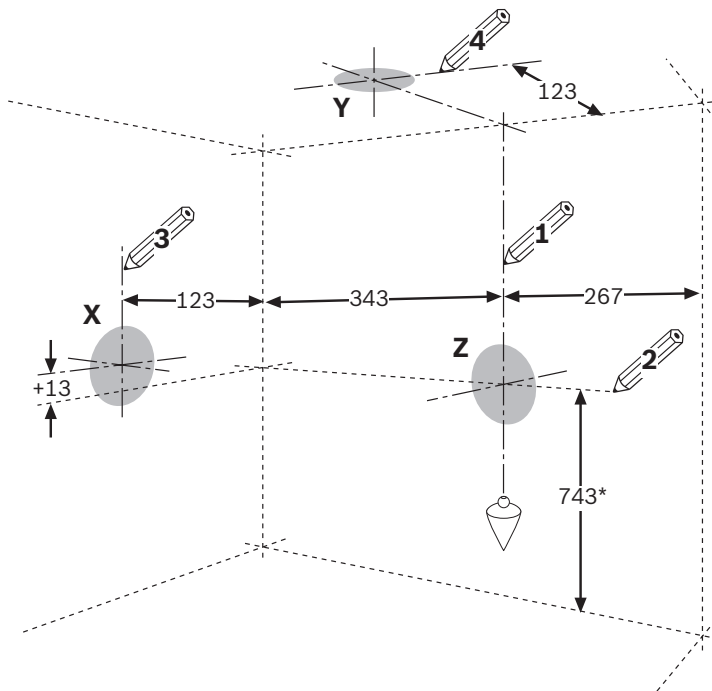
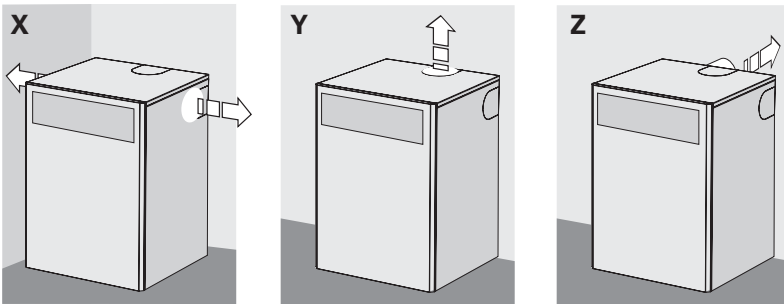

MOUNTING FRAME FIXING & FLUE OPENING

CAUTION: Ensure there are no pipes, electric cables, damp proof course or other hazards before drilling.

SAFETY:

All relevant safety precautions must be undertaken. Protective clothing, footwear, gloves and safety goggles must be worn as appropriate.

MOUNTING FRAME/PIPEWORK POSITIONS:

- A - Mounting frame.
- B - Manifold connections.
- C - Mounting frame fixing point.
- D - Wall.
- E - Gas and water pipework (not supplied).
- F - Boiler.

FIXING THE MOUNTING FRAME:

- ▶ Position the mounting frame (A) on the floor against the wall with manifold connections (B) facing away from the wall (D) ensuring there is enough space for the pipework (E).
- ▶ Allow the minimum space from each side of the frame (A) for the boiler overhang (F) and minimum service clearance, as shown.
- ▶ Ensure the mounting frame is level and mark fixing points (C).
- ▶ Secure mounting frame (A) to the floor using appropriate fixings (not supplied).
- ▶ Clear any debris from the site.

FLUE OPENING:

- ▶ Follow the diagram opposite to mark the centre of the flue (1, & 2) for rear opening, (2 & 3) for side opening or (1 & 4) for top opening.

Measurements shown include the minimum service clearances.

NOTE: All horizontal flue sections must rise away from the boiler by 52mm per meter to ensure that condensate flows back into the boiler for safe discharge via the condensate waste pipe.

- ▶ Cover the mounting frame manifold assembly (A) to protect the manifold connections.
- ▶ Make an opening (X or Z) through the wall using a core drill or similar at a size relative to the wall thickness as shown below:

Wall thickness	Flue opening 60/100mmØ	Flue opening 80/125mmØ
150 - 240mm	127mmØ	152mmØ
240 - 330mm	127mmØ	152mmØ
330 - 420mm	127mmØ	162mmØ
420 - 500mm	140mmØ	162mmØ

Where the flue terminal can only be fitted from inside the building, increase the opening to 150mmØ to allow the optional weather collar to fit through the opening for 60/100 flue.

- ▶ Clear away any debris.

MOUNTING FRAME CONNECTIONS

CAUTION: ISOLATE THE MAINS GAS SUPPLY BEFORE STARTING ANY WORK AND OBSERVE ALL RELEVANT SAFETY PRECAUTIONS.

GAS AND WATER CONNECTIONS:

- ▶ Ensure all pipework is clean and each pipe is in the correct position as shown opposite.
- ▶ Push in each pipe in turn and tighten the fitting to secure.

- A - CH flow (22mm)
- B - DHW flow (22mm)
- C - Gas inlet (22mm)
- D - Mains water inlet (22mm)
- E - CH return (22mm)
- F - Mounting frame.

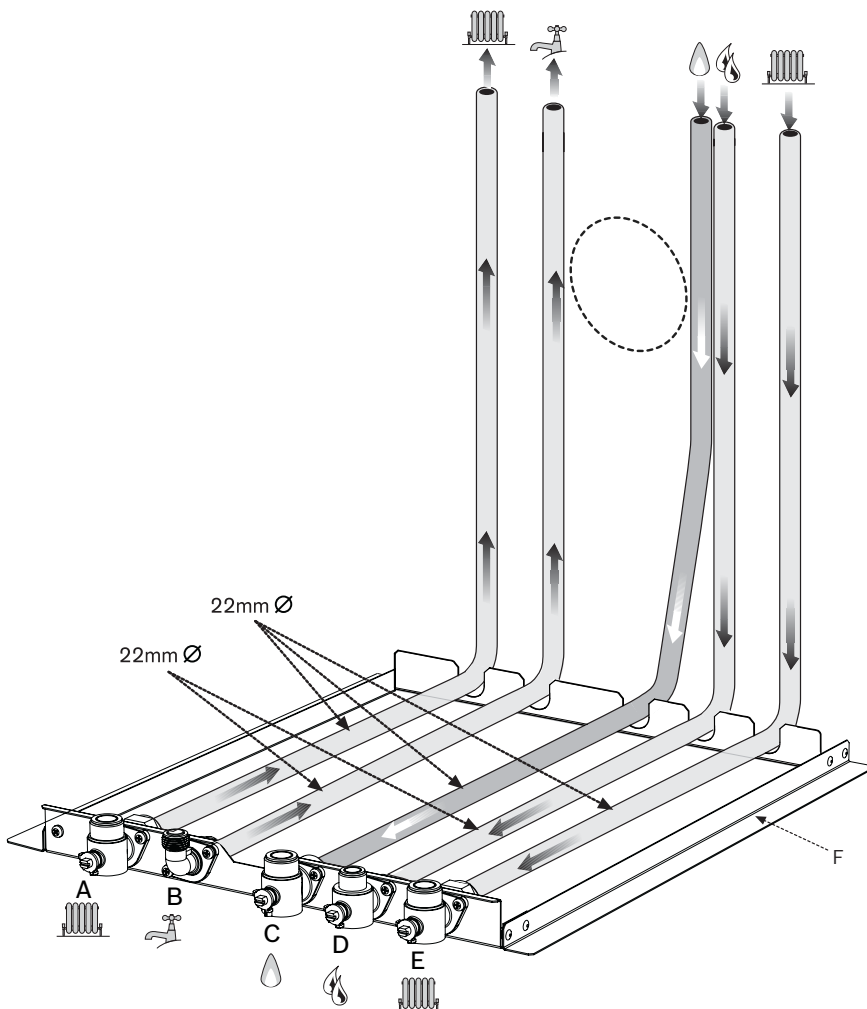

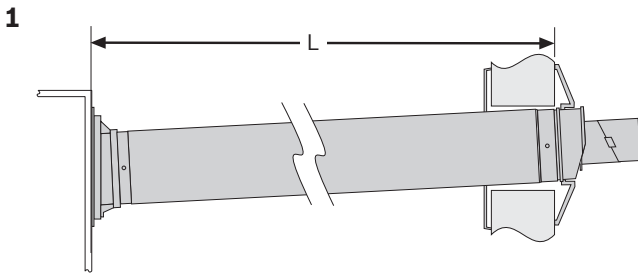

EFFECTIVE MAXIMUM STRAIGHT FLUE LENGTHS for Ø60/100mm Telescopic flue:

Appliance description	L max.
440CDi	4000mm
550CDi	4000mm

FLUE LENGTHS

HORIZONTAL FLUE:

(60/100mm diameter)

For vertical flues and 80/125mmØ horizontal flues, please refer to separate Flue manuals.

Ø60/100mm HORIZONTAL TELESCOPIC FLUE LENGTHS:

The maximum effective straight flue lengths (L) are stated opposite for the relevant appliance and must not be exceeded.

- ▶ Measure the total straight length (L) along the flue route, then add the following to length (L) to check the maximum flue length is not exceeded:
 - ▶ 2000mm for each extra 90° bend.
 - ▶ 1000mm for each extra 45° bend.

All dimensions in mm.

1 Example with one extension tube:

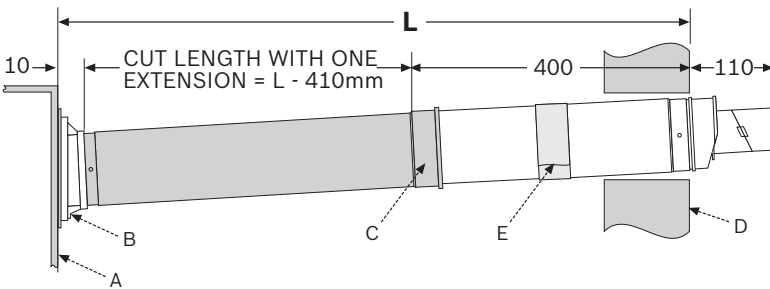

FLUE MEASURING & CUTTING

Do not exceed the maximum straight length for a horizontal Ø60/100mm flue or a Ø60mm plume management system (if used) as stated in this Instruction Manual or Flue Manual.

Cutting the flue to an exact measure is not normally required as the telescopic flue terminal allows for adjustment.

- ▶ Measure the flue length (L) from the boiler inner case (A) along the flue route to the outside wall (D).

Note, the terminal end projects beyond the outside wall by the distance shown opposite.

 - A - Boiler inner case.
 - B - Flue connector.
 - C - Flue extension tube socket.
 - D - Outside wall.
 - E - Aluminium tape over terminal screwed joint.

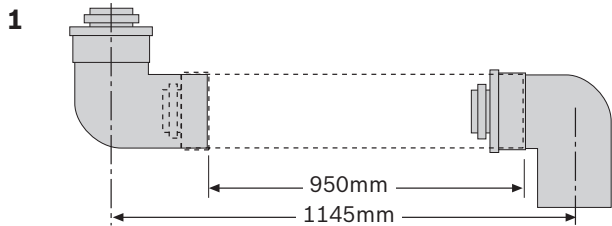

FLUE MEASURING & CUTTING

Flue bends:

- 1 ▶ Connecting flue bends increases the effective pipe length and an allowance must be made for the different connectors. The example opposite shows dimensions for two 90° bends connected to a standard flue extension.

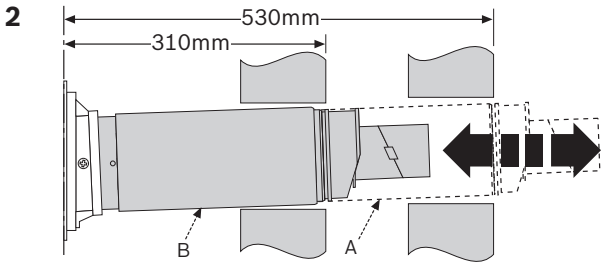

Adjusting the standard terminal length:

- 2 ▶ Extend tube (A) by withdrawing from tube (B) to achieve the flue length required, 310- 530mm.
- ▶ Secure with screw provided and seal joint with the aluminium tape supplied.

Reducing the standard terminal length:

- 3 ▶ Remove securing screws (C) to detach the terminal assembly from the connector.
- ▶ Slide terminal section (B) from the terminal assembly and discard.
- ▶ To use terminal (A) without cutting remove the location lug (D) on the inner flue tube (E) and remove any burrs.

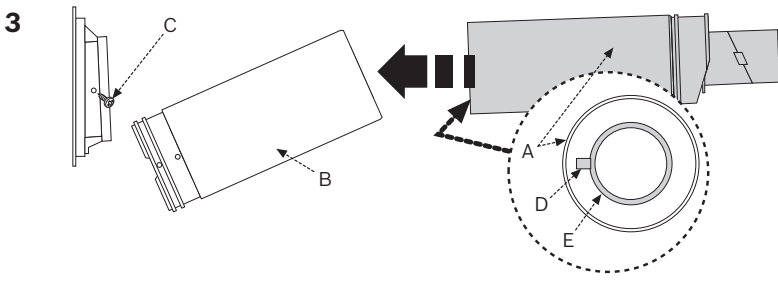

To reduce the terminal length further:

- 4 ▶ Mark the length required for the terminal (A) as shown (min. 130mm) and cut square, taking care not to damage the tubes.
 - ▶ Remove any burrs and chamfer the outer edge of the tubes to assist ease of connection and prevent seal damage.
- NOTE: The aluminium tape is not required when reducing the terminal.*

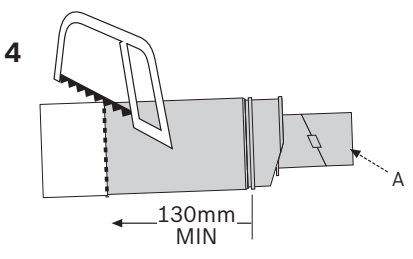

Reducing extended flue tube length:

- Only cut flue extension & not flue terminal.
- 5 ▶ Mark flue extension (F) to the required distance measuring from the socket end and cut square taking care not to damage the tubes.
- ▶ Remove any burrs and chamfer the outer edge of the tubes to assist ease of connection and prevent seal damage.

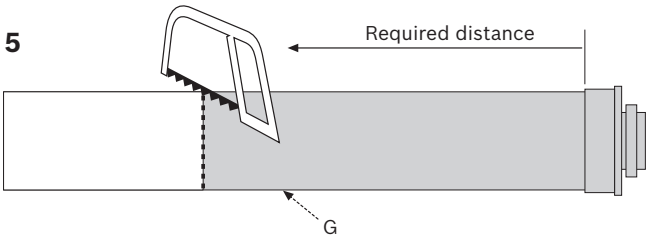

FLUE MEASURING & CUTTING

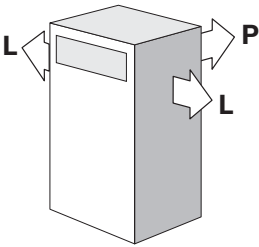

FLUE OUTLETS (L or P):

- 1 ▶ Remove seal (B) from flue adaptor (A).
- 2 ▶ Cut square to mark, as shown, deburr and clean.
- 3 ▶ Replace seal (B).

INSTALLATION

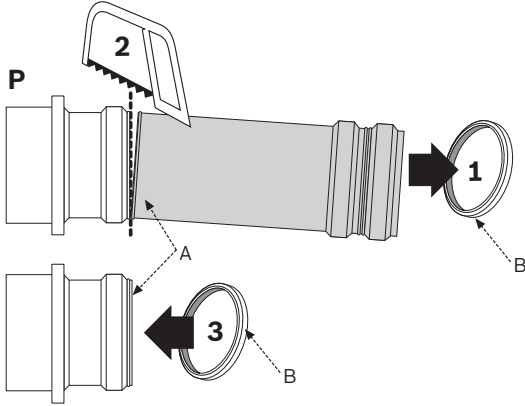
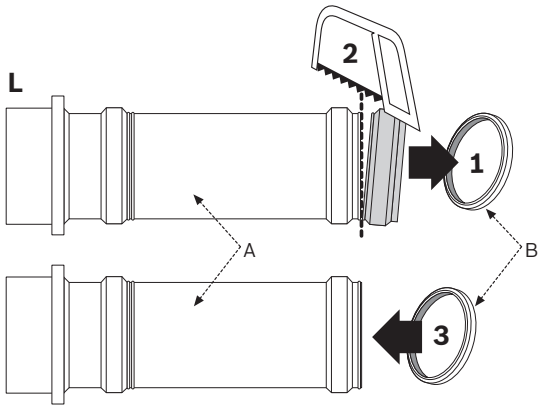

FLUE INSTALLATION

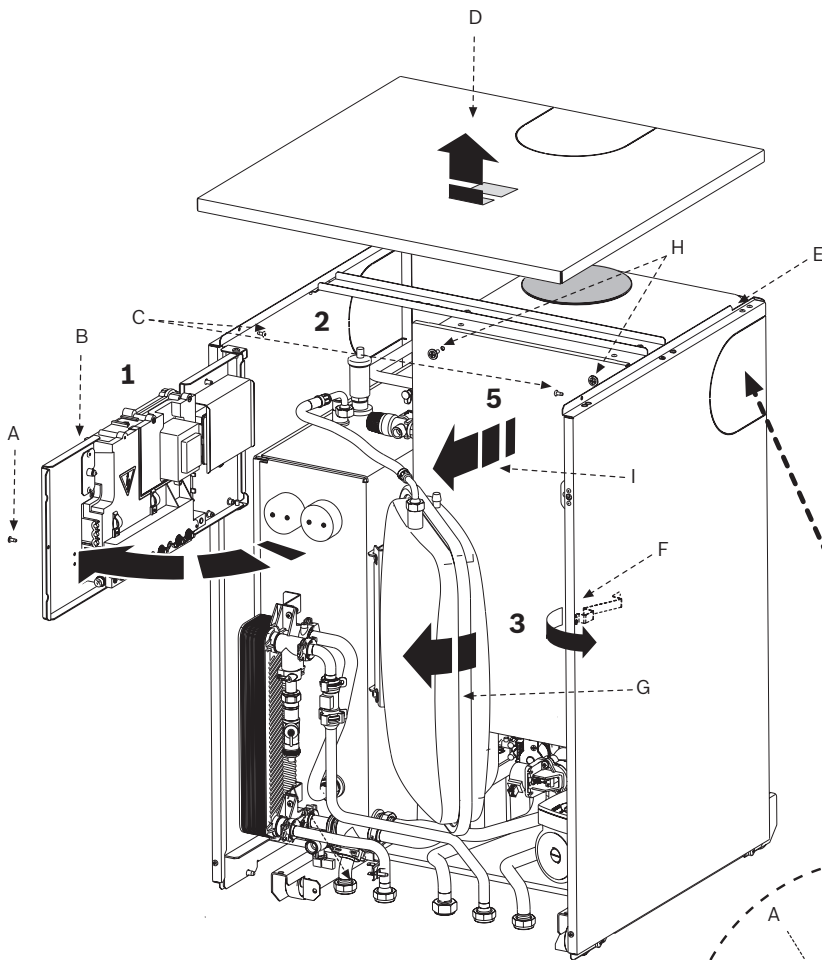

- 1 ▶ Remove retaining screw (A) to swing control panel assembly (B) outwards to its full extent.
- 2 ▶ Remove screws (C) from inside of casing.
 - ▶ Lift front of top panel (D) to release.
 - ▶ Pull forwards to disengage rear retainer (E), then lift panel (D) away from boiler.
- 3 ▶ Pull clip (F) outwards to release the expansion vessel (G).
- 4 ▶ Swing expansion vessel (G) outwards.

Note: for easier access to the inner case, the expansion vessel can be unhooked (by removing the retaining screw on the hinge) lowered and moved to the side. Take care not to overstretch the flexible pipe connections.

- 5 ▶ Release four screws (H) to remove the inner case cover (I).

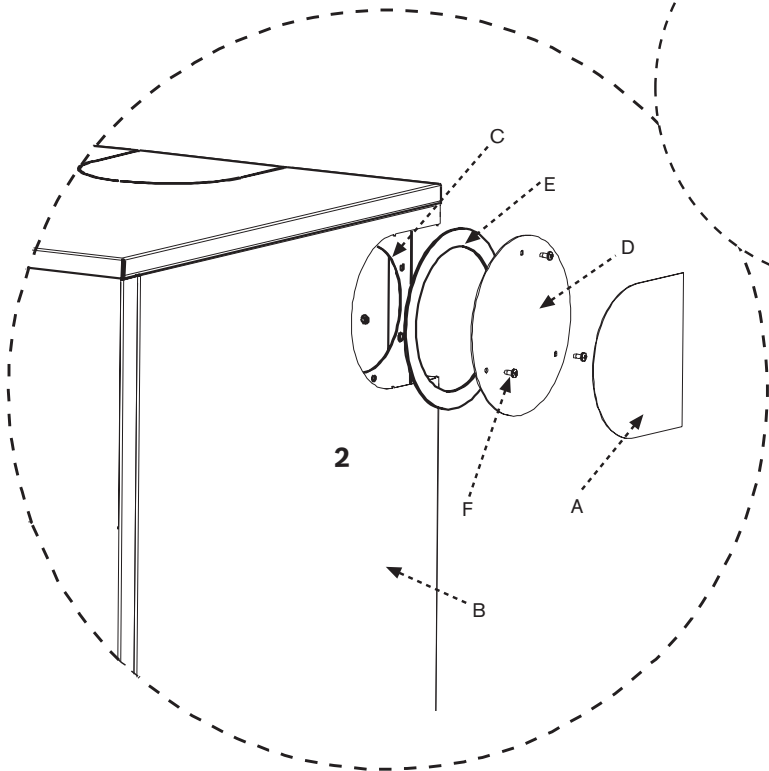

CONVERT FROM REAR FLUE OUTLET:

The boiler is supplied ready to fit a rear flue outlet. To flue from the sides or top of the boiler, follow the procedure below:

- 1 ▶ Remove and discard the required side or top 'knock-out' panel (A) from the outer casing (B).
- 2 ▶ Remove the flue outlet blanking plate comprising: cover (D) and gasket (E) from the inner casing (C) by removing the three screws (F).
- 3 ▶ Refit the outlet blanking plate over the rear flue outlet.

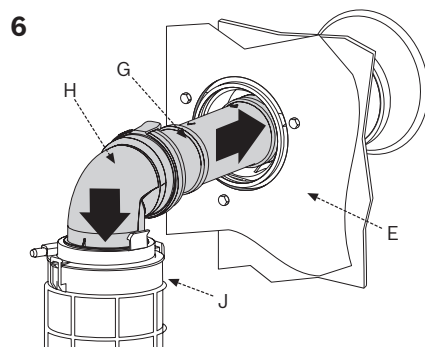
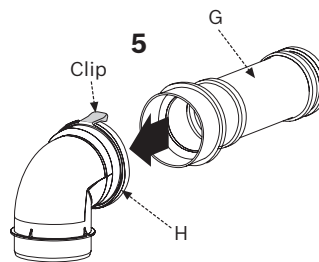
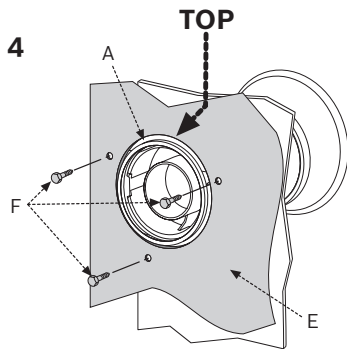
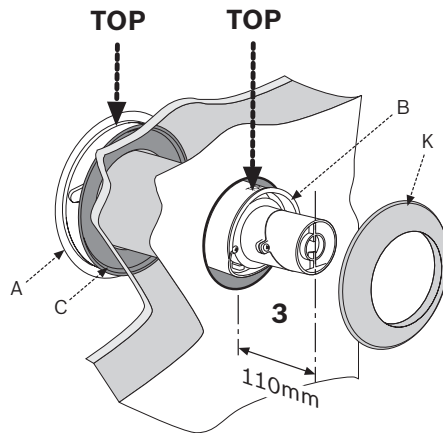
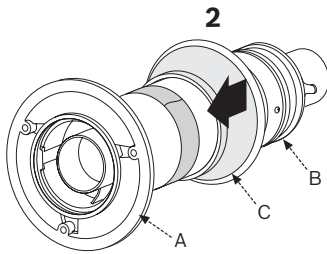
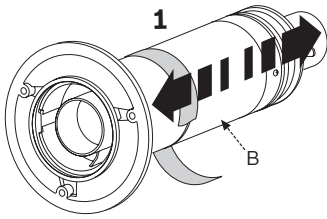

STANDARD FLUE INSTALLATION

NOTE: to ease assembly of the flue components, grease seals lightly with the solvent-free grease supplied.

Check all the seals are seated properly in the grooves provided and are in good condition.

All flue joints must be sealed to prevent leakage of condensate and flue products.

Installing the standard flue:

- 1 ▶ Set the flue terminal (B) to the distance required, secure with screw and seal joint with the aluminium tape supplied.
- 2 ▶ Slide the inner wall seal (C) onto the terminal (B) as shown.
 - ▶ If fitting from inside the building; slide the outer wall seal (K) onto terminal (B).
- 3 ▶ Position terminal (B) through the flue opening in the wall to the outside of the building by the distance shown and then pull back to create a seal.

▶ **The flue terminal (B) MUST be fitted with the label marked 'TOP' uppermost to allow the correct fit and use of the plume management system.**

- ▶ If fitting from the outside of the building; slide the outer wall seal (K) onto terminal (B) to fit against the outer wall and then pull back to create a seal.
- 4 ▶ Roll the boiler into position on the floor mounting frame.
 - ▶ Position connector (A) with the label marked 'TOP' uppermost to align with the three holes in the boiler inner casing (E).
 - ▶ Secure using three hexagonal bolts (F).
 - 5 ▶ Push-fit adaptor (G) into elbow (H) until secured by the clip.
 - 6 ▶ Slide adaptor (G) into the inner flue tube of terminal (B) and push elbow (H) into flue outlet (J) until secured by the retaining clips ensuring a good seal is made.

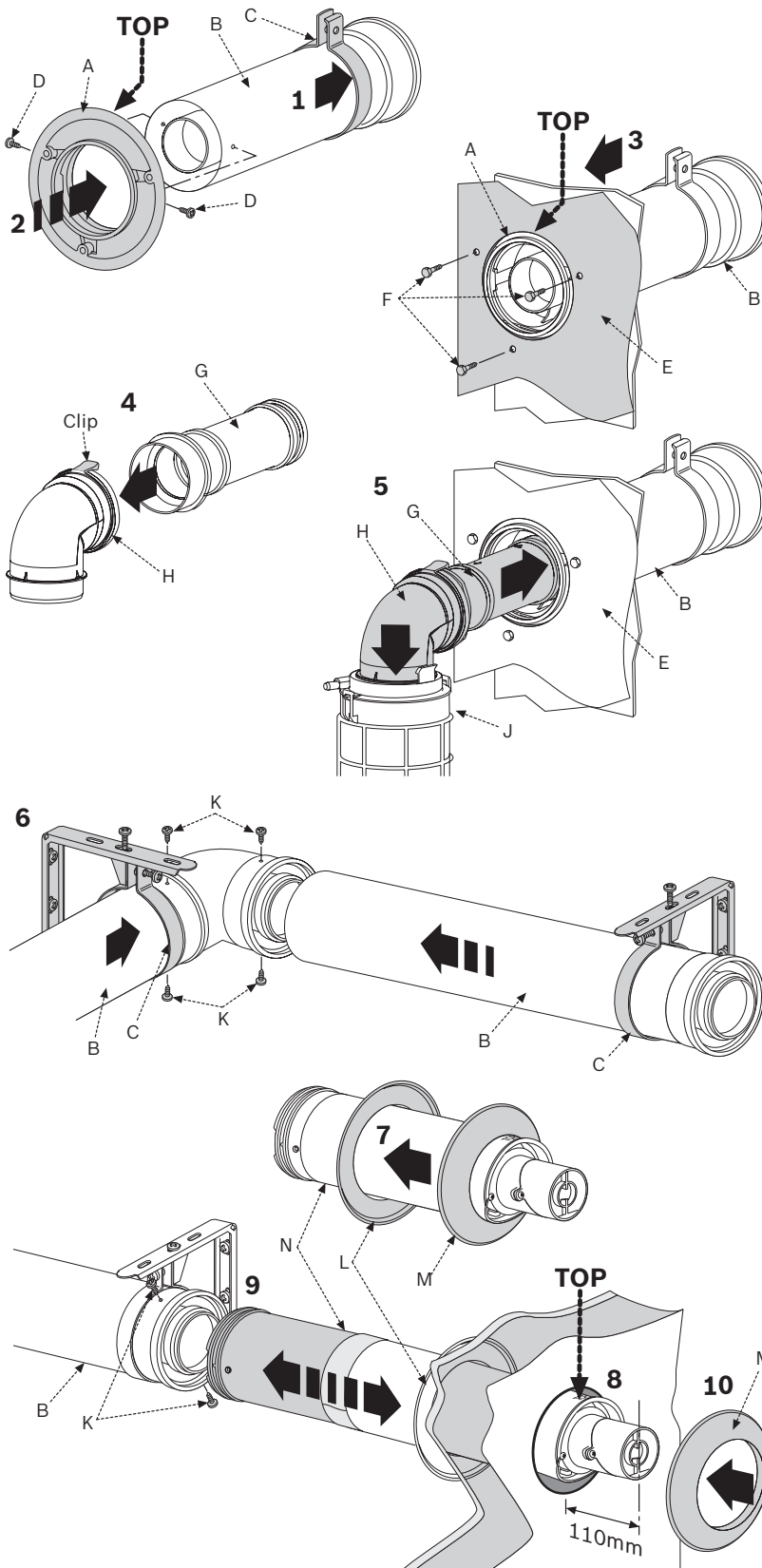
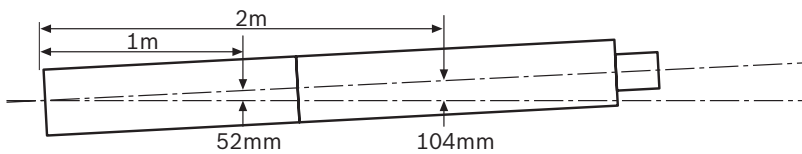

EXTENDED FLUE INSTALLATION

NOTE: to ease assembly of the flue components, grease seals lightly with the solvent-free grease supplied.

Check all the seals are seated properly in the grooves provided and are in good condition.

All flue joints must be sealed to prevent leakage of condensate and flue products.

All horizontal flue sections must rise by at least 52mm for each metre away from the boiler to ensure that condensate flows back into the boiler for safe discharge via the condensate waste pipe.

Installing an extended flue:

- 1 ▶ Slide a support clamp (C) (not supplied) onto a flue extension (B) as shown.
 - 2 ▶ Secure connector (A) to flue extension (B) using two screws (D).
 - 3 ▶ Support the weight of flue extension (B) and position connector (A) with label marked 'TOP' uppermost to align with the three holes in the boiler inner casing (E).
 - ▶ Secure using three hexagonal bolts (F).
 - 4 ▶ Push-fit adaptor (G) into elbow (H) until secured by the clip.
 - 5 ▶ Push-fit the adaptor (G) into the inner flue extension (B) and push elbow (H) into flue outlet (J) until secured by the retaining clips.
 - 6 ▶ Slide a support clamp (C) (not supplied) onto additional flue extensions (B).
 - ▶ Working from the boiler, fit the extension/s with support clamp/s as required, to take the weight of the flue.
 - ▶ Drill two holes (180° apart if possible) through the outer flue tube of each extension taking care NOT to drill the inner flue tube and secure with screws (K) as shown.
 - 7 ▶ Slide the inner wall seal (L) onto terminal (N).
 - ▶ If fitting from inside the building; slide the outer wall seal (M) onto terminal (N) as shown.
 - 8 ▶ Position terminal assembly (N) through the flue opening in the wall to the outside of the building by the distance shown and then pull back to create a seal..
 - 9 ▶ Fit terminal assembly (N) into the last extension (B).
- ▶ The flue terminal (N) MUST be fitted with the label 'TOP' uppermost to allow the correct fit and use of the plume management system.**

 - ▶ Drill the outer flue tubes and fix with screws (K).
- 10 ▶ If fitting from the outside of the building; slide the outer wall seal (M) onto terminal (N).

FLUE TERMINAL PLUME MANAGEMENT

The flue discharge can be redirected allowing some plume management control, alternatively, a complete plume management system can be fitted to the flue terminal.

Redirecting the flue discharge:

Important: should you wish to use the plume deflector please use the additional grease enclosed to ensure that an adequate seal is retained.

- 1 ▶ Remove screws (A) and terminal end (B).
- 2 ▶ Spread the extra grease supplied into the groove that runs around the terminal outlet (C) to ensure a good seal is retained.
- 3 ▶ Rotate the detached end section (B) to plume deflecting position, as shown and refit using screws (A).
- 4 ▶ Loosen screws (D) and rotate the terminal end (B & C) to redirect the plume.

DO NOT rotate the complete flue terminal assembly.

▶ Retighten screws (D) to secure in the required position.

NOTE: the flue terminal outlet has built-in stops to limit rotation for horizontal fluing to allow condensate to run back into the boiler for safe disposal. Do not attempt to force beyond the limit stops.

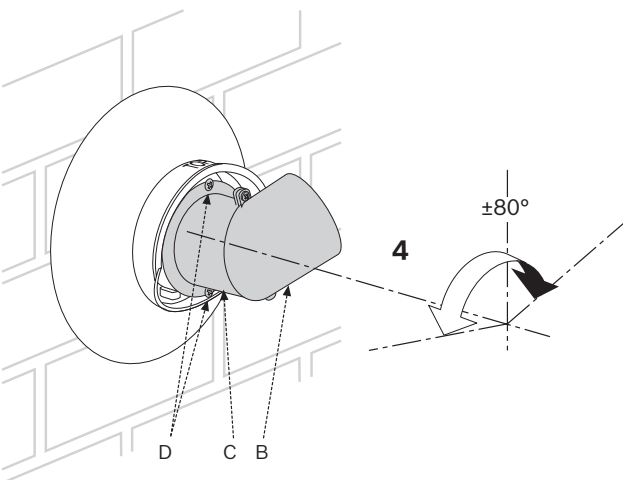
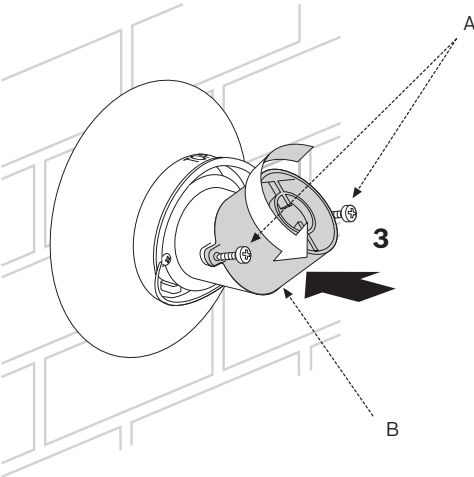
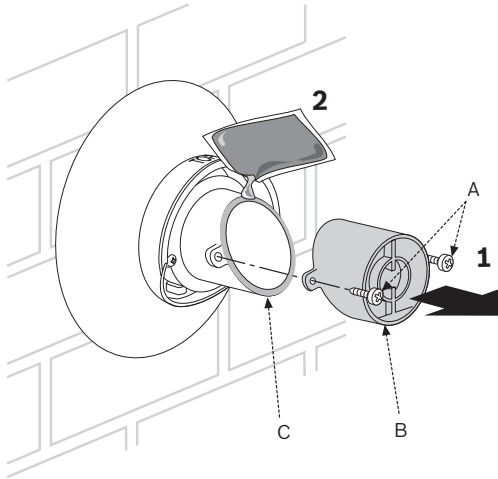

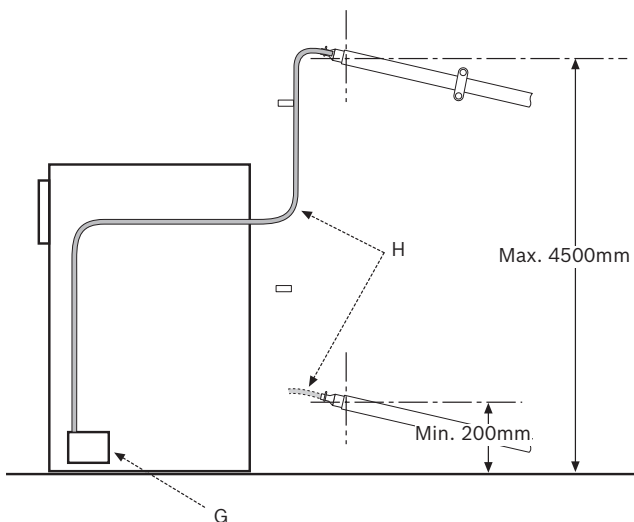

CONDENSATE, GAS & WATER CONNECTIONS

CONDENSATE CONNECTION:

The condensate pump (G) fills up and periodically discharges through the flexible condensate pipe (H) between 200mm to 4500mm from floor level. After this point the condensate flows, due to gravity, down the 21.5mm plastic pipe to the outlet.

- ▶ Fit the bayonet connector on the end of the condensate waste pipe to the end of the condensate pump. Push down and rotate clockwise until the connector is locked.
- ▶ Route and secure condensate waste pipe (H) with clips supplied to prevent kinking or restriction.
- ▶ Cut off any excess pipe (H).
- ▶ Fit the condensate waste pipe (H) to adaptor (K) and secure with clip (J).
- ▶ Connect adaptor (K) to 21.5mm plastic pipe and terminate into an internal waste trap.

(See Pre-Installation section for condensate pipework running from the adaptor (K) to the discharge outlet).

Never terminate or discharge into any open source, including; sink, bath, shower, bidet, toilet etc.

Note: Any external condensate pipework should be protected with weather resistant insulation to help prevent freezing.

The flexible pipe supplied can only be used inside the property.

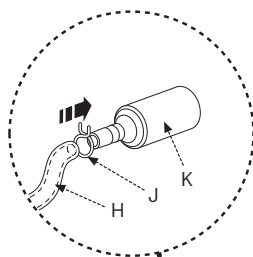

CAUTION: ISOLATE THE MAINS GAS AND WATER SUPPLY BEFORE STARTING ANY WORK AND OBSERVE ALL RELEVANT SAFETY PRECAUTIONS.

GAS AND WATER CONNECTIONS:

- ▶ Remove the transit bung (L) from the gas & water connections (A, B, C, D & E) on the boiler and mounting frame.

Note: that surplus water may be present due to factory testing.

- ▶ Ensure the area is clear of debris and manoeuvre the boiler rear wheels onto the outer rails of the mounting frame (F).
- ▶ Take care when moving the boiler to position the front wheels onto the rails and align the gas/water connections and the flue.
- ▶ Secure boiler to mounting frame (F) with screw (M)
- ▶ Place the 5 larger valve sealing washers (shown shaded) onto valves A, B, C, D & E.
- ▶ Ensure all pipework is clean.
- ▶ Tighten the compression fittings to secure:
 - A - CH flow (22mm).
 - B - DHW flow (22mm).
 - C - Gas inlet (22mm).
 - D - Mains water inlet (22mm).
 - E - CH return (22mm).

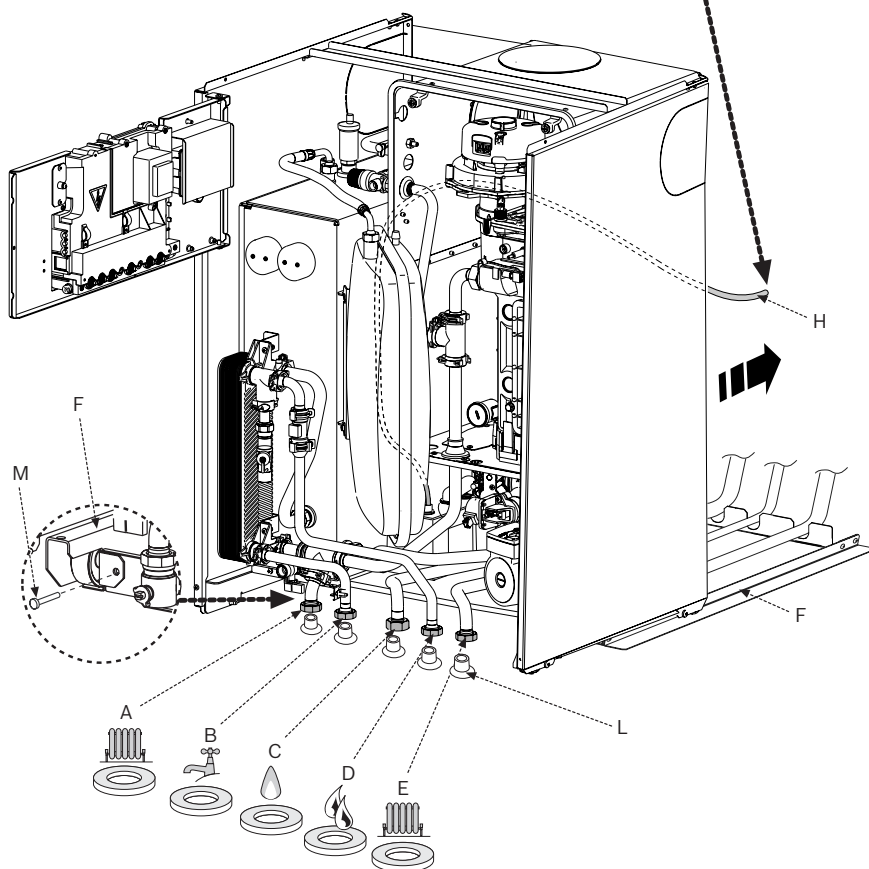

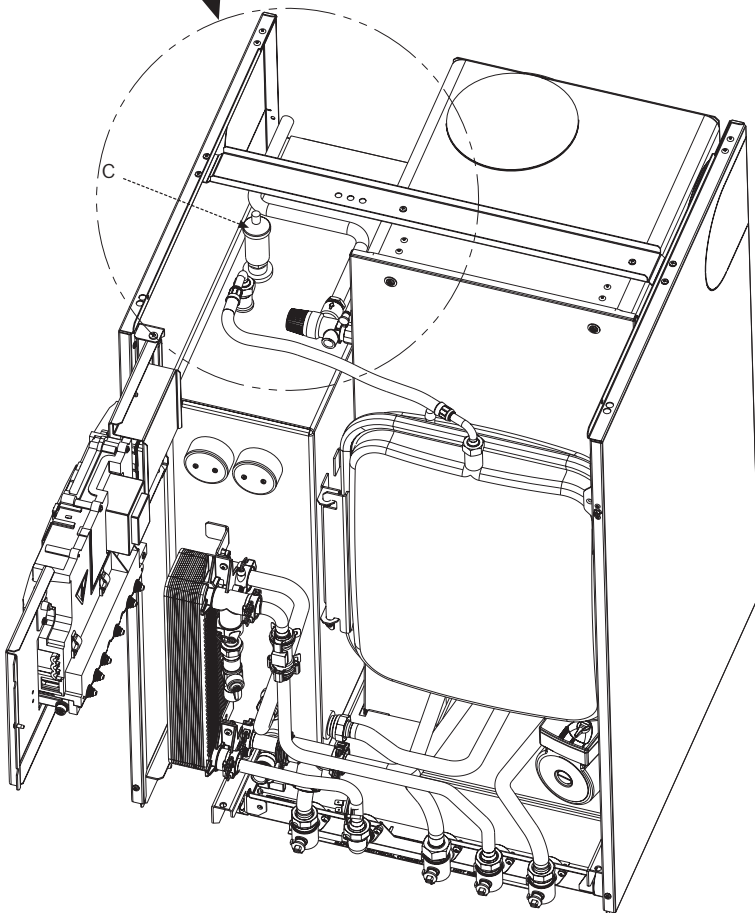
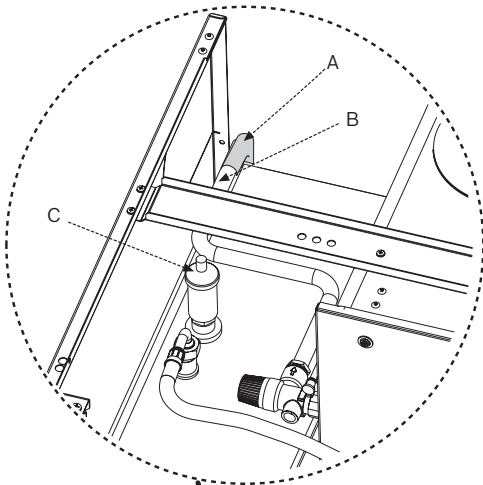

PRESSURE RELIEF VALVE OUTLET

Fitting the pressure relief valve drain pipe:

- ▶ Connect a length of 15mm copper pipe (A) to the P.R.V drain pipe (B).

The P.R.V drain pipe (B) should be at least 15mm diameter and run down away from any electrics or other hazard.

IMPORTANT: The pressure relief valve is a safety device for the boiler and if activated may discharge boiling water or steam through the P.R.V drain pipe.

Auto air vent:

- ▶ Remove the auto air vent cap (C) and discard.

ELECTRICAL

CAUTION: ISOLATE THE MAINS ELECTRICITY SUPPLY BEFORE STARTING ANY WORK AND OBSERVE ALL RELEVANT SAFETY PRECAUTIONS

Note: Mains supply to the boiler and system wiring centre must be through a common fused double pole isolator situated next to the boiler. The isolator must have a contact separation of 3mm minimum between all poles. Any system connected to the boiler must not have a separate electrical supply.

External fuse 3 Amps.

When stripping wires ensure copper strands do not fall into the control box.

Access to electrical connections:

Remove boiler casing to access control panel.

1 Remove screw (A) and swing the control panel into the service position.

2 Remove the three screws (B) in the control panel and remove the connections cover.

3 Unclip cable clamp (C).

4 Cut off the tapered cable entry to suit the cable diameter.

5 Unscrew cable retaining screw (D).

Run the cable through the cable clamp (C) ensuring there is ample cable to reach the connectors. Tighten the cable retaining screw D to secure the cable and replace clamp C into the control panel.

6 Mains power 230 Volt connection ST10:

- ▶ Separate wires from cable end and strip to 6mm
- ▶ Connect LIVE wire to terminal L
- ▶ Connect NEUTRAL wire to terminal N
- ▶ Connect EARTH wire to connector

NOTE:

Make the EARTH wire longer so that if the cable is snagged, the EARTH wire is the last to be pulled out.

7 Optional frost thermostat connection ST6:

- ▶ Connect frost thermostat supply wire to terminal Fs
- ▶ Connect frost thermostat return wire to terminal Fr

8 230V room thermostat and/or external timer ST10:

- ▶ Remove link
- ▶ Connect room thermostat LIVE supply to terminal Ls
- ▶ Connect room thermostat LIVE return to terminal LR
- ▶ Connect room thermostat NEUTRAL to terminal Ns

9 Refit all panels

Refer to manufacturers instructions when connecting external parts to the wiring centre.

Worcester, Bosch Group cannot be held responsible for wiring errors.

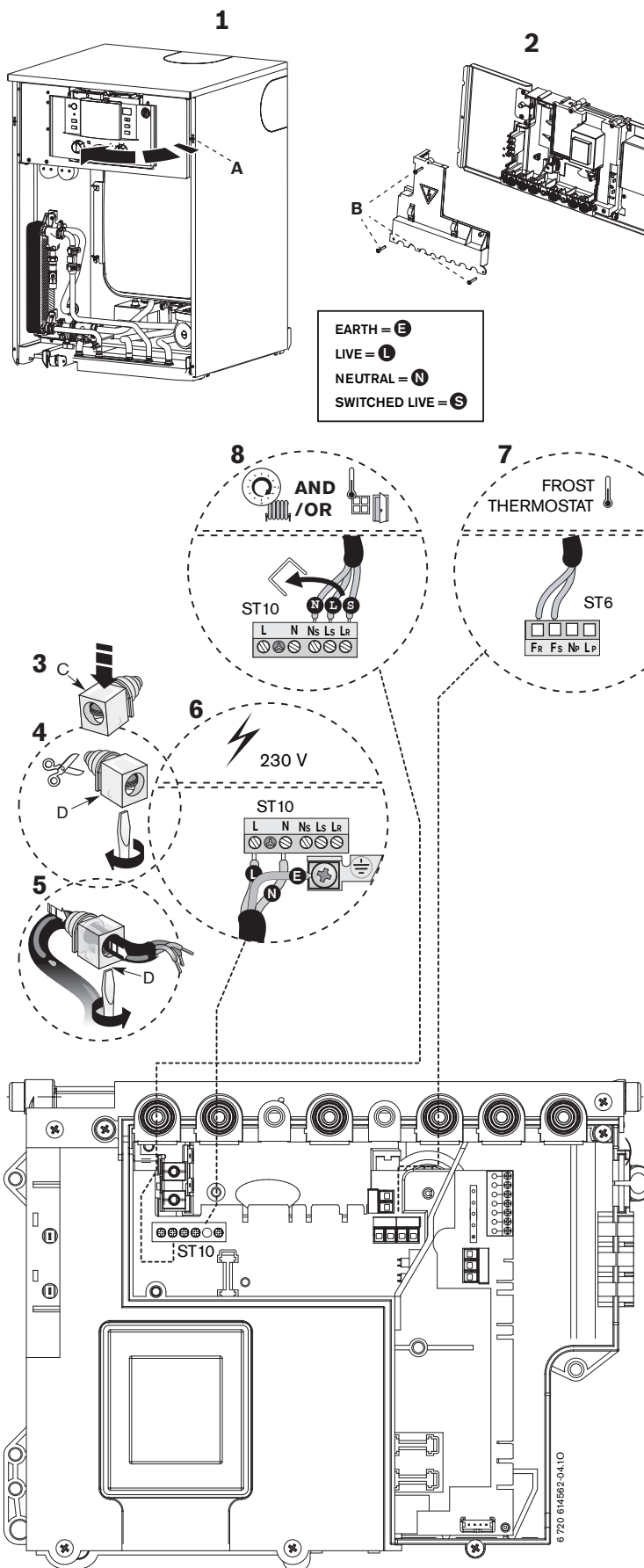

INSTALLATION

PRE-COMMISSIONING CHECKS

COMMISSIONING

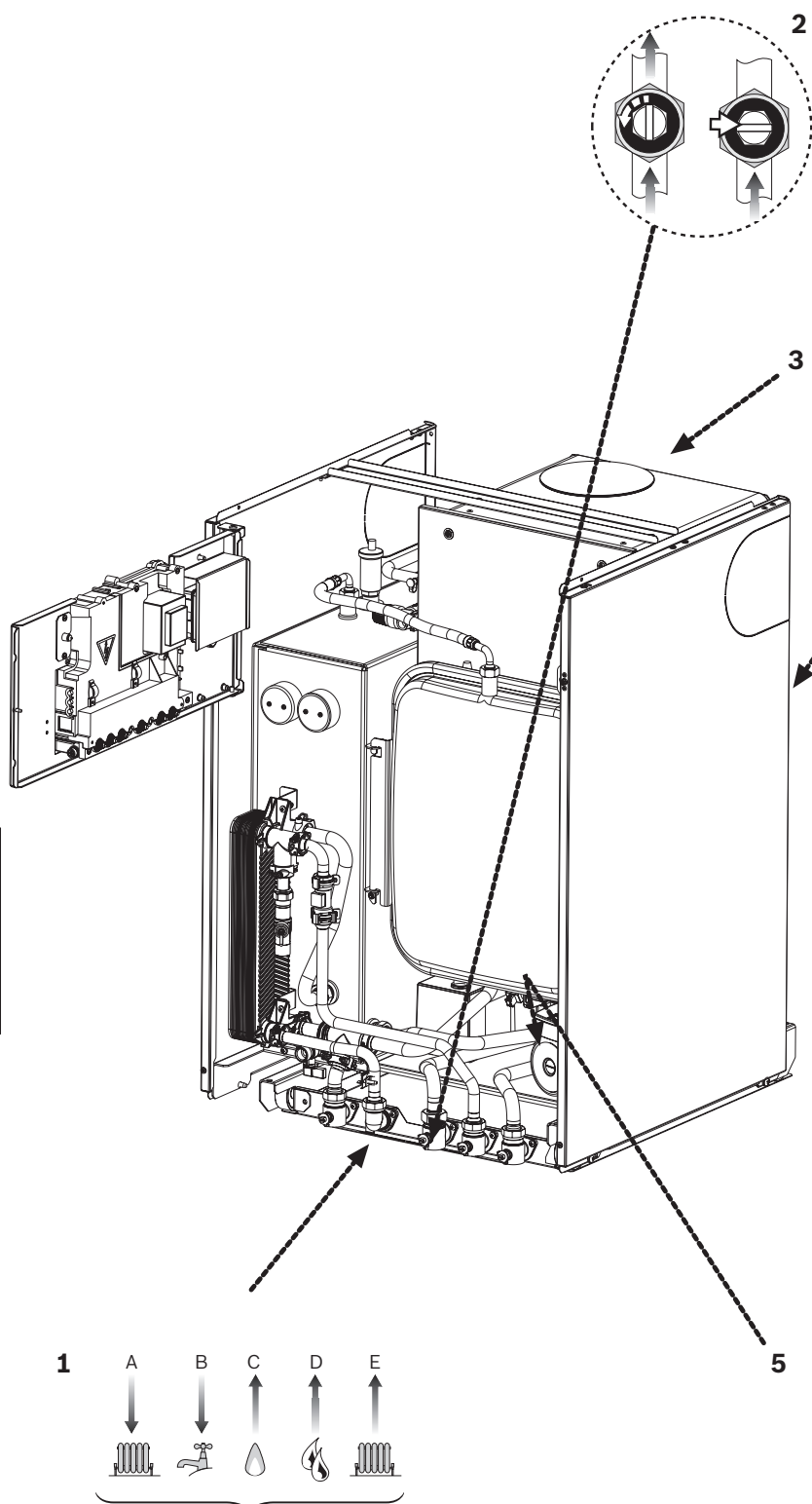

CAUTION: ISOLATE THE MAINS SUPPLIES BEFORE STARTING ANY WORK AND OBSERVE ALL RELEVANT SAFETY PRECAUTIONS.

- 1 ▶ Check that the service and water pipes are connected to the correct valve on the manifold;
- A - CH flow (22mm)
 - B - DHW flow (22mm)
 - C - Gas inlet (22mm)
 - D - Mains water inlet (22mm)
 - E - CH return (22mm)

- 2 ▶ Check the gas type specified on the identification plate matches that of the gas supply.
- ▶ Turn on the main gas supply, check the gas pipework, connections and rectify any leaks.

- 3 ▶ Check the flue is correctly fitted and the connections are secure.

- 4 ▶ Check the condensate pipework is correctly fitted and connected.

- 5 ▶ Check the CH circulating pump is set to 3.

Note: The CH circulating heating pump is preset to number '3' and should not be altered.

IMPORTANT: If the boiler is not to be commissioned immediately then: after successfully completing all of the checks and any rectification work, shut off the gas supply and electrically isolate the boiler. Complete the installation part of the Guarantee Registration Card.

FILLING THE SYSTEM

- 1 ▶ Turn on the water main and open the system valves (align slot vertically).
- 2 ▶ Open all radiator valves.
- 3 ▶ Unscrew the tank drain cap and connect the integral filling loop.
 - ▶ Open the flow and tank drain valves.
 - ▶ Fill the system to a pressure up to 2 bar.
 - ▶ Close the flow valve.
- 4 ▶ Vent all radiators, retighten the vent when completed.
 - ▶ Check the system and correct any leaks.
- 5 ▶ The boiler integral expansion vessel is pre-charged to 0.75bar (equal to a static head of 7.5m (22ft)). A Schraeder type valve is fitted to the expansion vessel to allow for pressure adjustment if required.

If an extra expansion vessel is fitted to the central heating return, adjust this to the same pressure as the appliance internal expansion tank, refer to separate instructions with the extra expansion vessel.

- 6 ▶ Briefly open the pressure relief valve to test its operation.
- 7 ▶ Close the tank drain valve.
 - ▶ Disconnect the integral filling loop.
 - ▶ Connect a suitable hose to the tank drain ensuring safe disposal of the discharge.
 - ▶ Open the tank drain valve to reduce the system pressure to the system pressure required, then close.
 - System pressure and capacity:
 - 1 bar 82 litres.
 - 1.5 bar 46 litres.
 - ▶ Rotate the adjustable pointer on the pressure gauge to record the set system pressure.
 - ▶ Disconnect the hose from the tank drain.
 - ▶ Refit tank drain cap.

IMPORTANT: Debris from the system can damage the boiler and reduce efficiency. Failure to comply with the guidelines for the use of water treatment with the appliance will invalidate the appliance warranty.

FLUSHING (Central Heating):

- ▶ Switch off the boiler.
- ▶ Open vented systems only: turn off the water to the system header tank.
- ▶ Open all radiator valves/drain cocks and drain the system while the appliance is hot.
- ▶ Close drain cocks.
- ▶ Add a suitable flushing agent and refill the system at the correct strength for the system condition in accordance with the manufacturer's instructions.
- ▶ Run the boiler/system at normal operating temperature for the time stated by the flushing agent manufacturer.
- ▶ Drain and thoroughly flush the system to remove the flushing agent and debris.

INHIBITOR (Central Heating):

- ▶ Check drain cocks are closed and all radiator valves are open.
- ▶ Add a suitable* inhibitor, (or combined inhibitor/anti-freeze if the system is exposed to freezing conditions) to the heating system in accordance with the manufacturers instructions.

The inhibitor or combined inhibitor/anti-freeze must not cause damage to the materials within the boiler (aluminium, stainless steel, copper and brass) and any other materials/components within the system.

- ▶ Open vented systems only: turn on the water to the system header tank and allow the system to fill.
- ▶ Sealed systems only: fill the system to between 1 and 2 bar via a WRAS approved filling loop.
- ▶ Vent the boiler and all radiators; retighten vents when complete.
- ▶ Record the date when the inhibitor was added to the system on the guarantee card.

NOTE:

The concentration level of inhibitor in the system should be checked every 12 months or sooner if system content is lost.

The addition of sealing agents to the system water is not recommended as this can cause problems with deposits left in the heat exchanger.

*** compatible with aluminium. The pH value of the system water must be less than 8 or the appliance guarantee will be invalidated.**

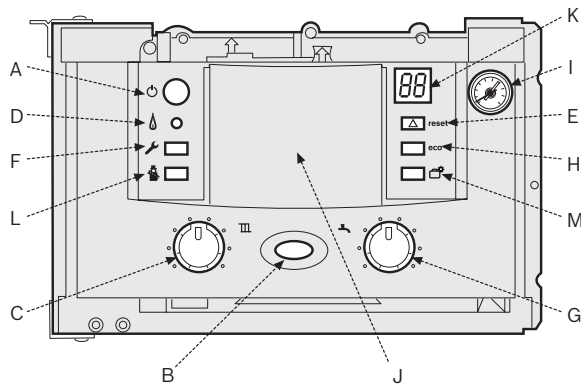

- A - MASTER SWITCH FOR ON/OFF
- B - MAINS ON/OFF INDICATOR + FAULT DIAGNOSTIC LIGHT
- C - CENTRAL HEATING TEMPERATURE CONTROL
- D - BURNER ON INDICATOR LIGHT (GREEN)
- E - FAULT RESET BUTTON
- F - SERVICE BUTTON
- G - DOMESTIC HOT WATER TEMPERATURE CONTROL
- H - ECO BUTTON (DOMESTIC HOT WATER PRE-HEAT ON/OFF)
- I - SYSTEM PRESSURE GAUGE
- J - POSITION FOR OPTIONAL PROGRAMMER
- K - DISPLAY
- L - CENTRAL HEATING BOOST BUTTON
- M - NOT USED

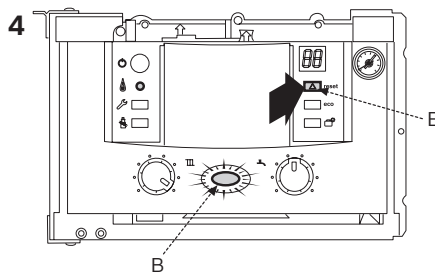
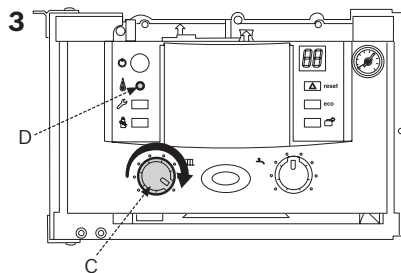
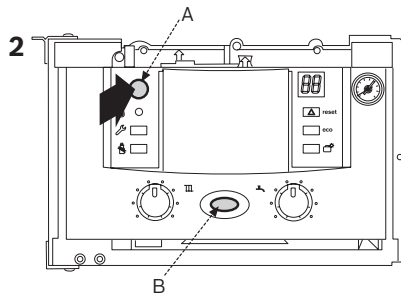
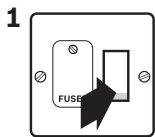

STARTING THE APPLIANCE

IMPORTANT: Never run the appliance when the appliance or system is empty or unpressurised.

Switching the appliance on/off:

- 1 ▶ Turn on mains power supply.
 - ▶ Turn on any external controls.
 - ▶ Set the thermostatic radiator controls to maximum.
 - ▶ Set the clock/programmer to continuously ON and the room thermostat to maximum temperature.
- 2 ▶ Press button (A) and the power on indicator (B) illuminates blue.
- 3 ▶ Turn the temperature control (C) to maximum. The burner on indicator (D) illuminates green when the burner has lit.

Note: the boiler runs for 15 minutes at minimum heating output to fill the condensate trap. This occurs every time the mains supply has been interrupted.

- 4 ▶ If the boiler fails to light, the blue power indicator (B) and reset button (E) will flash alternately.
 - ▶ To reset the boiler, press and hold the reset button (E) for 2 seconds.

CAUTION: DO NOT PRESS THE POWER INDICATOR (B) TO RESET THE BOILER.

THE COMBUSTION FOR THE APPLIANCE IS FACTORY SET.

NO ADJUSTMENT IS REQUIRED IF THE GAS INLET PRESSURE IS CORRECT.

CHECKING THE GAS INLET PRESSURE:

The inlet pressure to the appliance must be checked using the following procedure:

SETTING THE BOILER TO MAXIMUM:

- ▶ Press boost button for ten seconds and set temperature to maximum.

The boost button will illuminate continually.

MEASURING THE INLET PRESSURE:

- ▶ Slacken the screw in the inlet pressure test point and connect a manometer.
- ▶ Measure the pressure with the boiler running at maximum.
- ▶ Check the gas supply working pressure at the gas valve inlet point:
 - N.G. minimum 17-19 mbar, nominal 18 mbar
 - L.P.G. 35-39 mbar, nominal 37 mbar
- ▶ The gas rate should be measured at the gas meter after 10 minutes operation at maximum. See Technical Data section at the front of this manual.
- ▶ (L.P.G.) where a gas meter is not available the CO/CO₂ must be checked to units shown in "Setting the air/gas ratio" section.
- ▶ Ensure inlet pressure is satisfactory with all other gas appliances working.
- ▶ Replace controls cover. NOTE: this boiler is designed with a differential of 20°C across the heating system.

IMPORTANT: Do not continue commissioning until the correct gas inlet pressure is achieved.

- ▶ If pressure is satisfactory press the boost button again and the boiler will return to normal operation.

If left in service mode the control will return to normal operation after 15 minutes.

- ▶ Reseal the screw in the gas inlet pressure test point.

COMMISSIONING

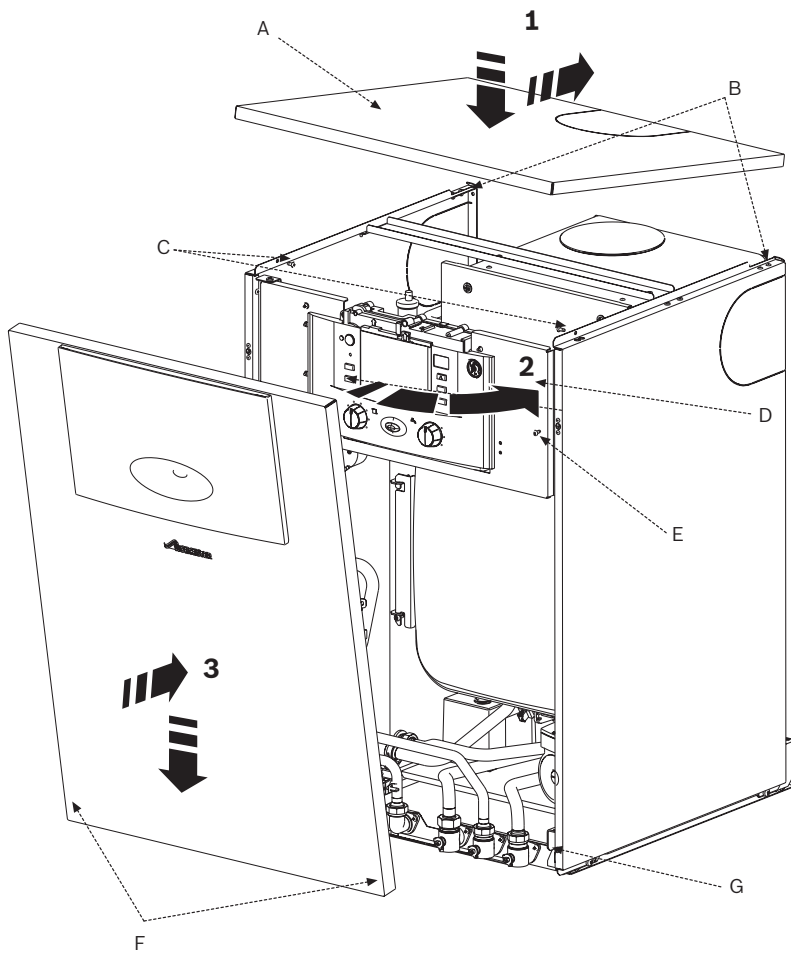

FINISHING COMMISSIONING

- 1 ▶ Engage top panel (A) onto rear retainers (B) and lower front of panel into position.
▶ Secure with screws (C).
- 2 ▶ Swing control panel assembly (D) into the boiler.
▶ Secure with screw (E).
- 3 ▶ Locate bottom corners of the front panel (F) into retainers (G).
▶ Push top of door to engage clips.

HANDOVER:

- ▶ Complete the Benchmark log book at the rear of the manual.
 - ▶ Set up the controls and show the user how to operate all the controls shown in the User Guide.
 - ▶ Instruct the customer how to repressurise the system.
 - ▶ If the appliance is unused and exposed to freezing conditions, advise the customer of the precautions necessary to prevent damage to the boiler, system and building.
- In the event of the appliance being inoperative, isolate the boiler and drain the system and boiler.

CAUTION: TURN OFF THE GAS SUPPLY AND ISOLATE THE MAINS SUPPLIES BEFORE STARTING ANY WORK AND OBSERVE ALL RELEVANT SAFETY

IMPORTANT: AFTER REPLACEMENT OF ANY COMPONENTS ALWAYS CHECK FOR GAS SOUNDNESS WHERE RELEVANT AND CARRY OUT FUNCTIONAL CHECKS AS DESCRIBED IN COMMISSIONING. ANY O-RING OR GASKET THAT APPEARS DAMAGED MUST BE REPLACED.

INSPECTION & SERVICE

IMPORTANT: Any service work must be carried out by competent registered engineers, such as British Gas or other CORGI registered personnel.

NOTE: A service must NOT be attempted if a CO/CO₂ analyser is NOT available.

- To ensure the continued efficient operation of the appliance it must be checked at regular intervals.
- The frequency of servicing will depend upon the particular installation conditions and usage however, an annual service is recommended.
- The extent of the service required by the appliance is determined by the operating condition of the appliance when tested by fully qualified engineers.

INSPECTION:

- ▶ Check that the terminal and terminal guard, if fitted, are clear and undamaged.
- ▶ If the appliance is in a compartment or cupboard check that the specified service space around the appliance is clear.
See 'Boiler Location & Clearances' under the Pre-Installation section for compartment clearances.
- ▶ Check all the joints and connections in the system and remake any that show signs of leakage. Refill and re-pressurise the system.
See 'Filling the System' and 'Water Treatment' under the Commissioning section.
- ▶ Operate the appliance and take note of any irregularities. Call up the last fault stored by the Bosch Heatronic, Service Function '6A'.
Refer to 'Fault Finding' under the Fault Finding & Diagrams section for display codes and rectification procedures.

SERVICE FUNCTION:

Setting boiler to maximum:

Note: when running in the heating boost mode, the boiler will operate both the Central Heating and DHW circuits. This is to allow sufficient time for setting procedure.

It will be necessary to run water through the DHW circuit to ensure that the boiler will not cycle on low heating demands.

- ▶ Press and HOLD central heating boost button (L) for 10 seconds and set Central Heating temperature to maximum.
The central heating boost button will illuminate continually.
The boiler will stay in this mode for 15 minutes unless the central heating boost button is pressed again.

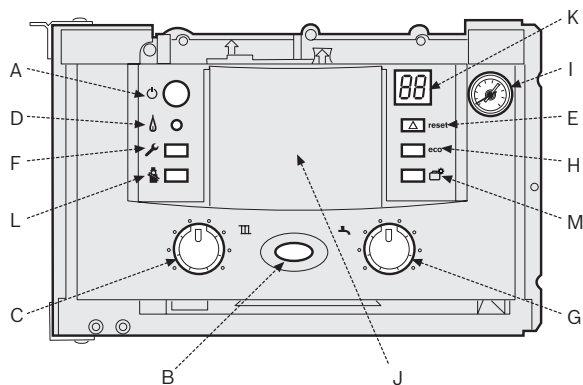

- A - MASTER SWITCH FOR ON/OFF
- B - MAINS ON/OFF INDICATOR + FAULT DIAGNOSTIC LIGHT
- C - CENTRAL HEATING TEMPERATURE CONTROL
- D - BURNER ON INDICATOR LIGHT (GREEN)
- E - FAULT RESET BUTTON
- F - SERVICE BUTTON
- G - DOMESTIC HOT WATER TEMPERATURE CONTROL
- H - ECO BUTTON (DOMESTIC HOT WATER PRE-HEAT ON/OFF)
- I - SYSTEM PRESSURE GAUGE
- J - POSITION FOR OPTIONAL PROGRAMMER
- K - DISPLAY
- L - CENTRAL HEATING BOOST BUTTON
- M - NOT USED

SERVICING
& SPARES

INSPECTION & SERVICE

COMPONENT ACCESS:

1 ▶ Grip the outer sides of the front panel (A) pull and lift away from retaining lugs (B).

2 ▶ Remove retaining screw (C) to swing control panel assembly (D) outwards to its full extent.

3 ▶ Pull clip (E) outwards to release expansion vessel (F).

4 ▶ Swing expansion vessel (F) outwards.

Note: for easier access to the inner case, the expansion vessel can be unhooked (by removing the retaining screw on the hinge) lowered and moved to the side. Take care not to overstretch the flexible pipe connections.

5 ▶ Release four screws (G) to remove the inner case cover (H).

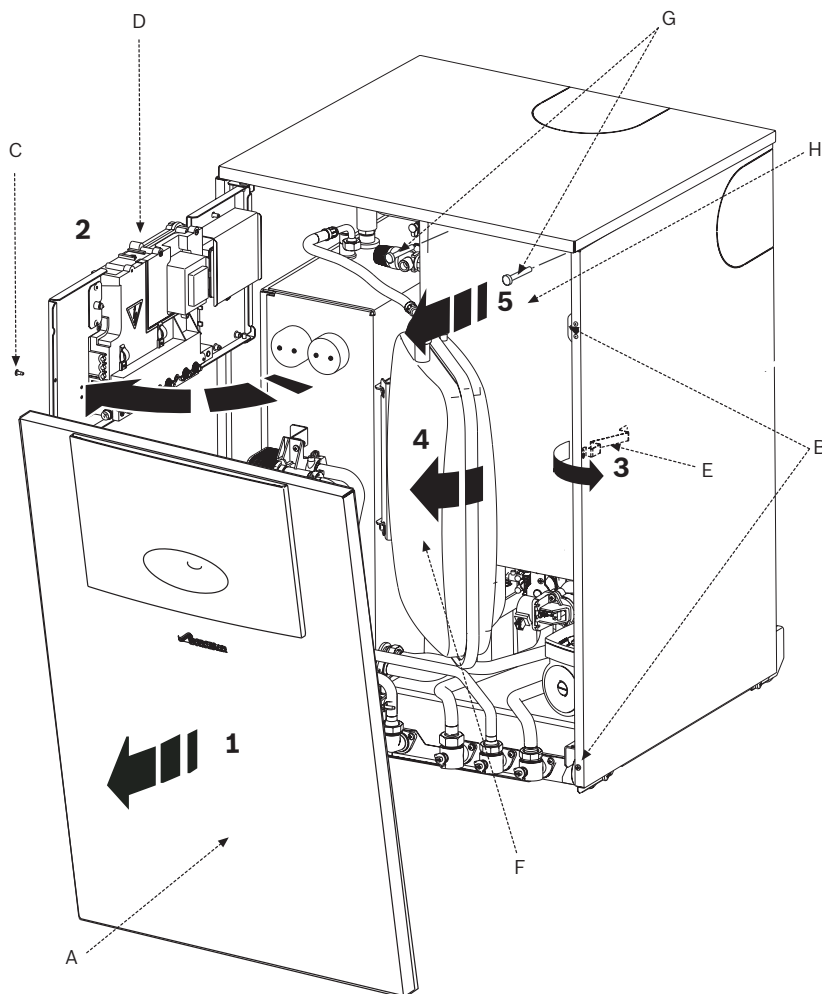

IMPORTANT: AFTER COMPLETING THE APPLIANCE SERVICE THE CO/CO₂ MUST BE CHECKED AND SET TO THE LIMITS IN THE SECTION "AIR/GAS RATIO".

INSPECTION & SERVICE

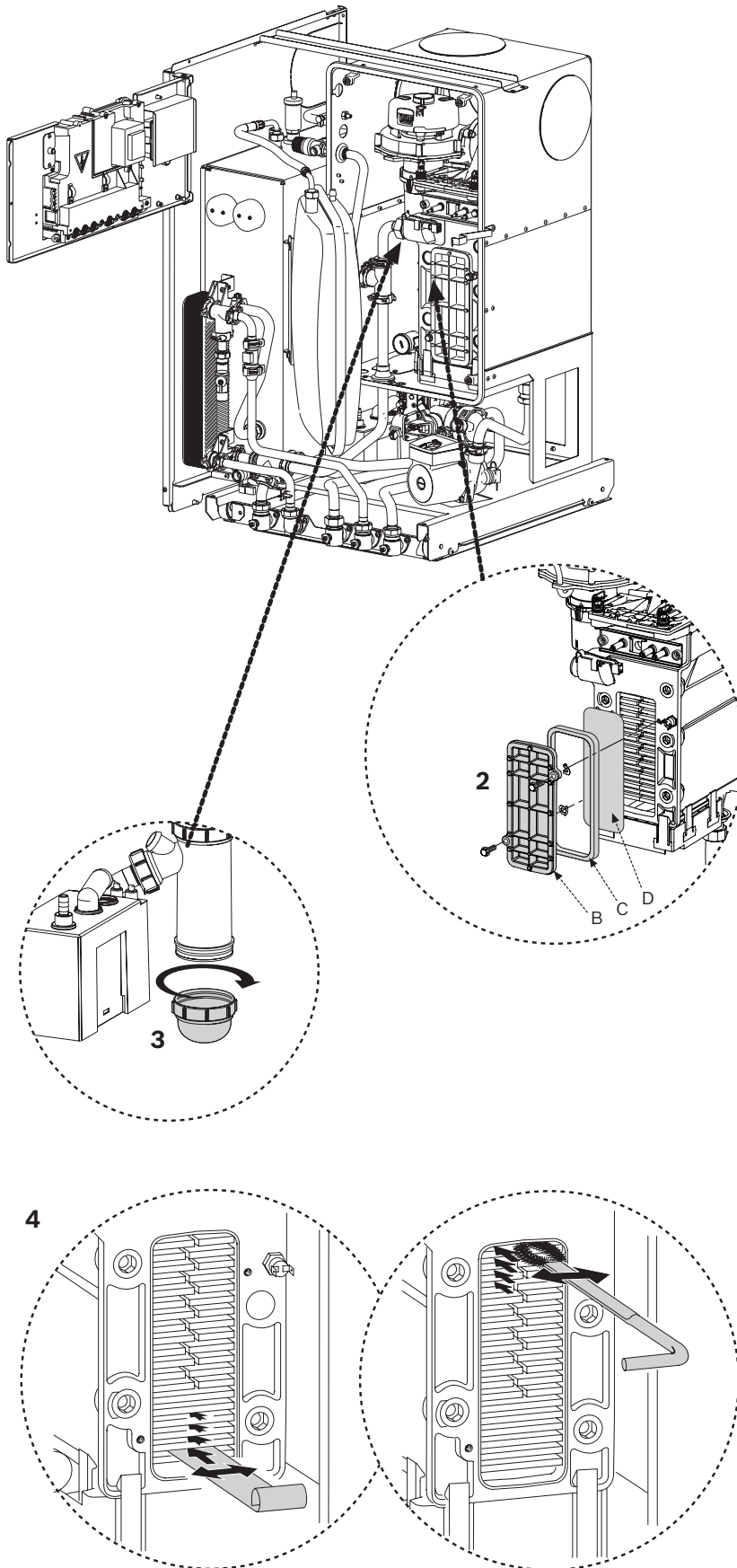

Primary Heat Exchanger:

There is a special accessory kit available (No. 840) specifically designed for cleaning the heat exchanger. If required order 7 719 001 996.

- 1 ▶ Pull the cover off (A) and connect a manometer to the fan pressure test point.

▶ After measurement replace test point cover.

Pressure will read negative and be greater than:

440CDi - 4.1 mbar

550CDi - 5.2 mbar

Pressures measured less than these figures will indicate that the heat exchanger will require cleaning.

- 2 ▶ Remove the cleaning access cover (B), seal (C) and metal plate (D) securing it, if present.

- 3 ▶ Unscrew the condensate trap cap and place a suitable container underneath.

To Remove Condensate pump:

▶ Disengage condensate pipe from condensate pump.

▶ Remove condensate pump from base panel.

▶ After servicing the heat exchanger, fill the condensate trap with approximately 1/4 litre of water and refit in reverse order.

To Clean the Heat Exchanger:

- 4 ▶ A Loosen any deposits in the heat exchanger from top to bottom using the cleaning blade.

▶ Clean the heat exchanger from top to bottom using the brush.

▶ Refit the clean out coverplates in reverse order using a new seal (C) and tighten screws to a torque of approximately 5 Nm.

▶ After re-assembly check CO/CO₂ levels as described in the section "Setting the air/gas ratio".

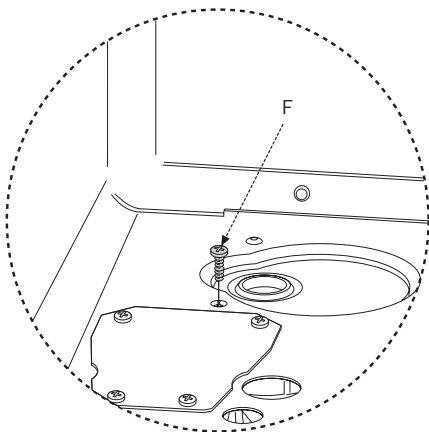
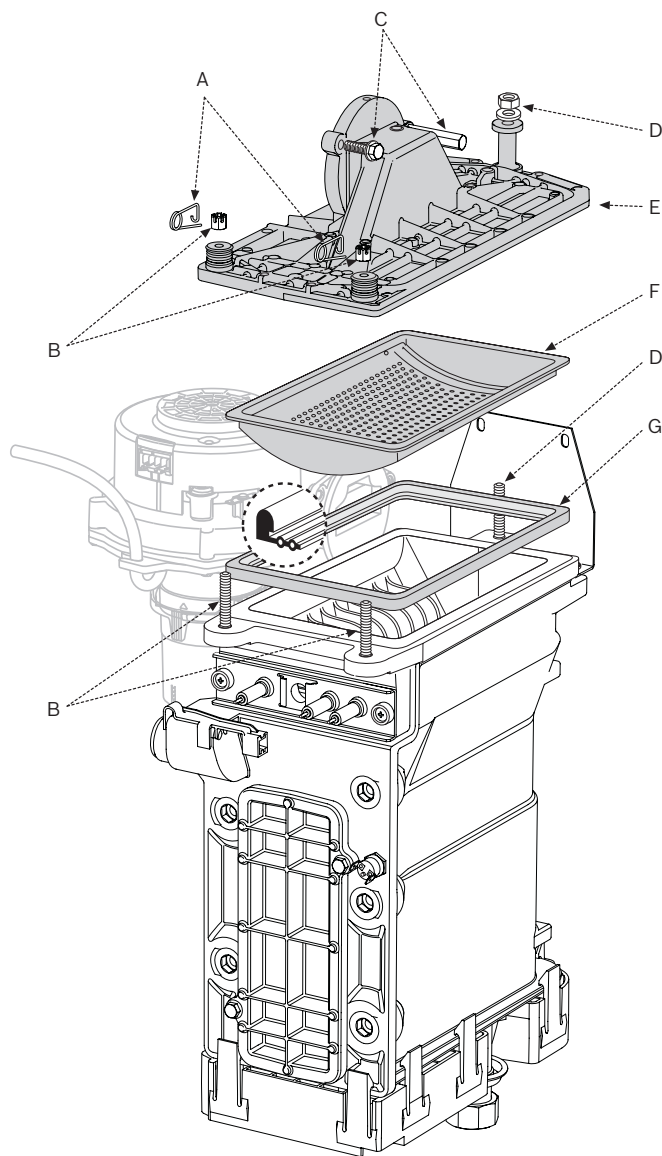

INSPECTION AND SERVICE

Burner:

- ▶ Check that the boiler is completely isolated from the gas supply.
- 1 ▶ Remove the clips (A) and unscrew the castellated nuts (B).
 - ▶ Remove springs.
 - ▶ Unscrew and remove the two hexagon screws (C) securing the fan.
 - ▶ Slacken fully the rear securing bolt (D).
 - ▶ Remove the burner cover plate (E).
- 2 ▶ Remove the burner (F) and clean the components.

Do not use a wire brush.

- ▶ Re-assemble burner in reverse order using a new seal (G).
- ▶ After re-assembly check CO/CO₂ levels as described in the section "Setting the air/gas ratio".

For sealed systems only:

Max pressure:

- ▶ When the heating system water is at maximum temperature, 2.5 bar must not be exceeded. If this pressure is exceeded then an extra expansion vessel must be fitted into the system return as close as possible to the appliance.
- ▶ If the system does not retain the pressure, the expansion vessel and the heating system should be checked for leaks.

Electrical wiring:

- ▶ Check the electrical wiring for physical damage and replace any damaged wires.

To check the diaphragm in burner cover:

- ▶ Carefully withdraw diaphragm from fan intake tube and check for soiling and splits.
- ▶ Carefully refit diaphragm the correct way round into the fan intake tube.

Note: The flaps of the diaphragm must open upwards.
- ▶ Re- assemble burner in reverse order using a new seal.
- ▶ After re-assembly check CO/CO₂ levels as described in the section "Setting the air/gas ratio".

To clean the condensate trap:

- ▶ Remove pipe from condensate pump.
- ▶ Remove screw retaining trap (F) and push trap downwards until clear.
- ▶ Remove trap from boiler along with pipe to condensate pump.

CAUTION: TURN OFF THE GAS SUPPLY AND ISOLATE THE MAINS ELECTRICAL SUPPLY BEFORE STARTING ANY WORK AND OBSERVE ALL RELEVANT SAFETY PRECAUTIONS. DRAIN THE BOILER/SYSTEM WHERE NECESSARY AND PROTECT ANY ELECTRICS FROM WATER INGRESS DURING COMPONENT REPLACEMENT.

IMPORTANT: Refit or replace any components removed from the appliance in the reverse order using new gaskets/'O' rings/sealant/heat transfer paste where necessary.

Any 'O' ring or gasket that appears damaged must be replaced. Always check that any electrical connections are correctly made and that all screws are tight.

AFTER REPLACEMENT OF ANY COMPONENTS ALWAYS CHECK FOR GAS SOUNDNESS WHERE RELEVANT AND CARRY OUT FUNCTIONAL CHECKS AS DESCRIBED IN THE COMMISSIONING SECTION.

REPLACEMENT PARTS

IMPORTANT: Any service work must be carried out by competent registered engineers, such as British Gas or other CORGI registered personnel.

IMPORTANT: After re-assembly the combustion must be checked using the procedure in the section "Setting the air/gas ratio". Measurement and setting of the gas ratio must not be attempted unless the person is equipped with a combustion analyser conforming to BS 7927 and is competent in its use.

DRAINING THE APPLIANCE:

- ▶ Turn off the system heating flow and return stop cocks - external to boiler.
- ▶ Using a suitable hose, attach one end to the drain tap on the boiler return elbow and lead the other end of the hose to an external drain point.
- ▶ Fully open the drain tap on the boiler return elbow.
- ▶ Close the drain tap when the flow from the appliance has stopped and remove the hose.

NOTE:

A small quantity of water may remain in some components even after the appliance has been drained. Protect any electrical components when removing items from the water circuits.

PCB CONTROL BOARD & TRANSFORMER:

Access to boiler control components

- ▶ Remove screws (A) to release the cover from the controller.

PCB Fuse

- ▶ Remove the fuse (B) and replace with a spare that are clipped on the inside of the controller cover.

Transformer / PCB

- ▶ Disconnect all electrical connections from the control.
- ▶ Remove the screws (C) retaining the rear panel of the control and remove the panel.
- ▶ After re-assembly check CO/CO₂ levels as described in the section "Setting the air/gas ratio".

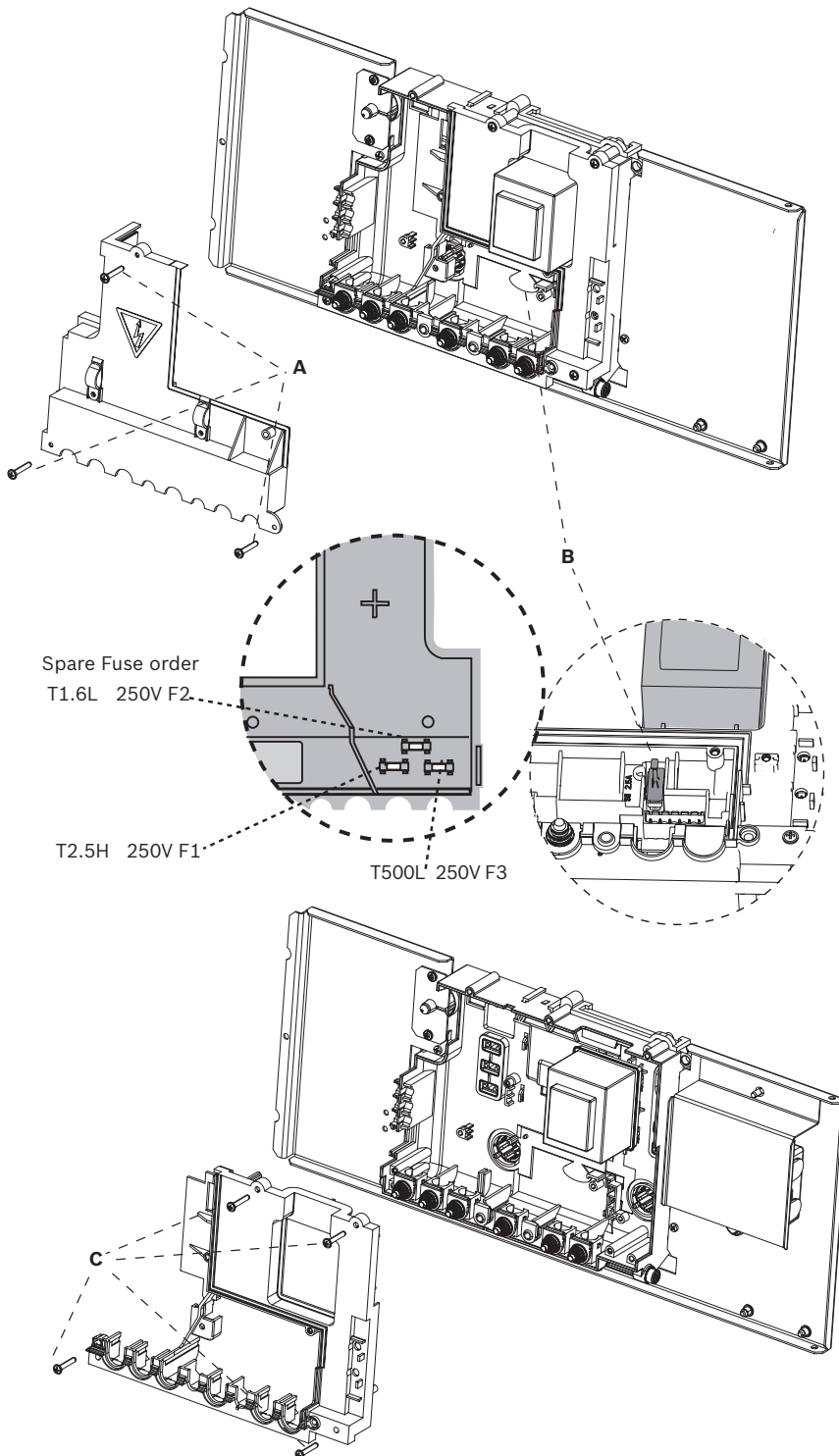

NOTE: A SERVICE TO THE FAN ASSEMBLY AND FLAP VALVE MUST NOT BE ATTEMPTED IF A CO/CO₂ ANALYSER IS NOT AVAILABLE.

REPLACEMENT PARTS

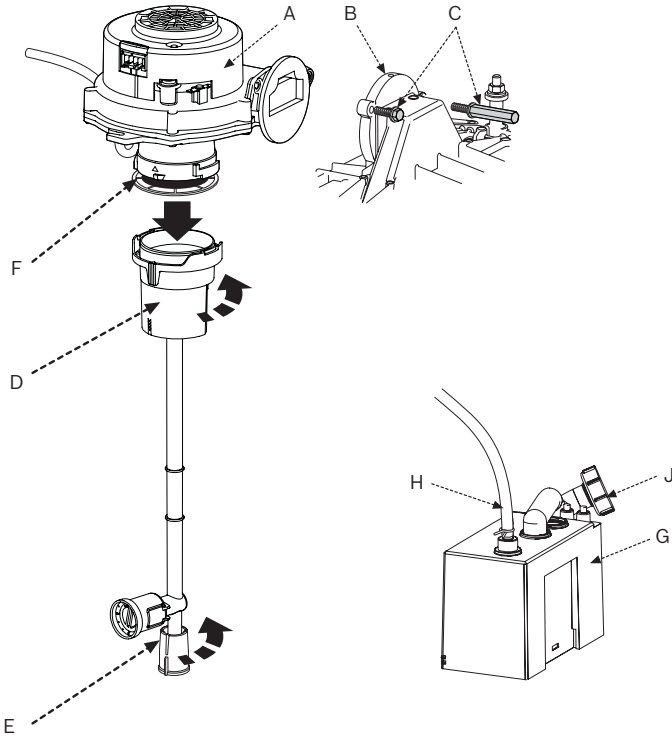

Fan Assembly:

- ▶ Undo lower pipe union on gas pipe (E).
- ▶ Remove fan lead and earth connector.
The earth connector has a positive clip fixing.
- ▶ Remove fixing screws attaching fan (A) to the burner cover (B).
- ▶ Remove fan (A) with gas pipe (E) and mixer unit (D).
- ▶ Twist mixer unit (D) with gas pipe (E) to separate from fan (A).
- ▶ After re-assembly check CO/CO₂ levels as described in the section "Setting the air/gas ratio".

Flap Valve:

- ▶ Undo lower pipe union on gas pipe (E).
- ▶ Remove pipe (E) by pushing upwards and to the rear.
- ▶ Twist mixer unit (D) with gas pipe (E) to separate from fan (A).
- ▶ Remove flap valve (F) from within fan intake (A) and replace.
- ▶ After re-assembly check CO/CO₂ levels as described in the section "Setting the air/gas ratio".

NOTE: Ensure the flap valve is fitted correctly with rubber flap upwards.

Condensate pump:

- ▶ Disconnect electrical connections in control box, see wiring schematic in the 'Fault finding & Diagrams' section.
- ▶ Remove 15mm flexible tube (H) from pump by rotating anti-clockwise and pulling up.
- ▶ Remove black flexible pipe (J) from condensate tank. Take care as there may be condensate remaining in the pipe.
- ▶ Carefully remove the condensate pump (G) from the boiler and pour any excess condensate into a suitable container for safe disposal.

Diverter valve motor

- ▶ Ensure that the appliance is in service mode (there is no need to drain the appliance).
- ▶ Disconnect the electrical connector (K) from the diverter valve motor (L).
- ▶ Pull the motor (L) towards you, the assembly will slide free from the valve.
- ▶ To refit, follow the reverse of above.

NOTE: In case of problems when refitting the motor: connect the electrical connector to the motor and switch the appliance on. When the motor goes into the middle position the motor can be fitted without difficulty.

Diverter valve

- ▶ Ensure that the appliance has been fully drained.
- ▶ Disconnect the electrical connector (K) from the diverter valve motor (L).
- ▶ Undo the two screws holding the valve actuator body to the plastic housing (N).
- ▶ Remove the motor and valve actuator body from the diverter valve.
- ▶ Withdraw the valve actuator from the diverter valve.
- ▶ To refit assemble in reverse, ensuring that the valve actuator is properly seated on the two lugs of the actuator body.

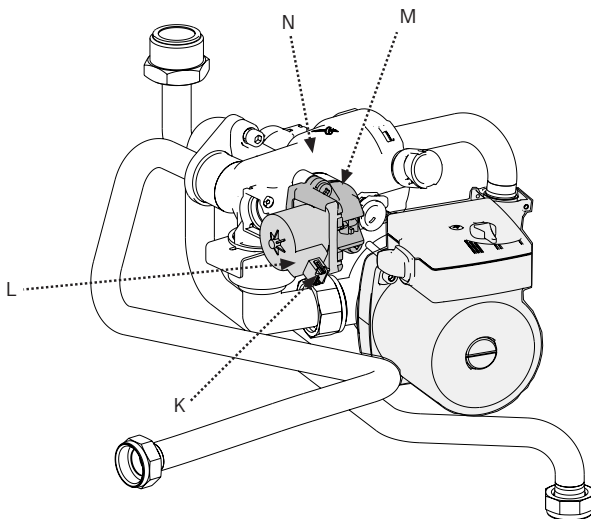

REPLACEMENT PARTS

Sensors:

- ▶ Check that the appliance is electrically isolated.

Central heating flow temperature sensor (A):

- ▶ Remove the connector.
- ▶ Release the sensor clip and withdraw the sensor.
- ▶ Apply heat transfer paste to the replacement sensor.

Drain the system first: Safety temperature limiter (B):

- ▶ Remove the connectors.
- ▶ Unscrew the sensor.

Tank sensor (C):

- ▶ Remove screws retaining plastic cover.
- ▶ Remove cover and disconnect 2 electrical connections.
- ▶ Unscrew 2 hexagon studs.
- ▶ Replace sensor coating surface with paste supplied.
- ▶ Re-assemble.

Tank overheat thermostat (D):

- ▶ Remove screws retaining plastic cover.
- ▶ Remove cover and disconnect 2 electrical connections.
- ▶ Unscrew 2 hexagon studs.
- ▶ Replace sensor coating surface with paste supplied.
- ▶ Re-assemble.

Flow sensor/flow regulator assembly (E):

- ▶ Shut off mains water at inlet valve and drain DHW circuit.
- ▶ Disconnect inline connector.
- ▶ Remove 2 retaining clips (F).
- ▶ Remove flow sensor assembly (E).
- ▶ Remove brass housing with flow regulator (G) from sensor.
- ▶ Re-assemble ensuring that retaining clips are correctly positioned.

Flue Temperature limiter (H):

- ▶ Remove the connector.
- ▶ Unscrew the sensor.

Domestic hot water temperature sensor (J):

- ▶ Release and pull-off the connector.
- ▶ Unscrew the bracket.
- ▶ Replace sensor coating surface with paste supplied.
- ▶ Re-assemble.

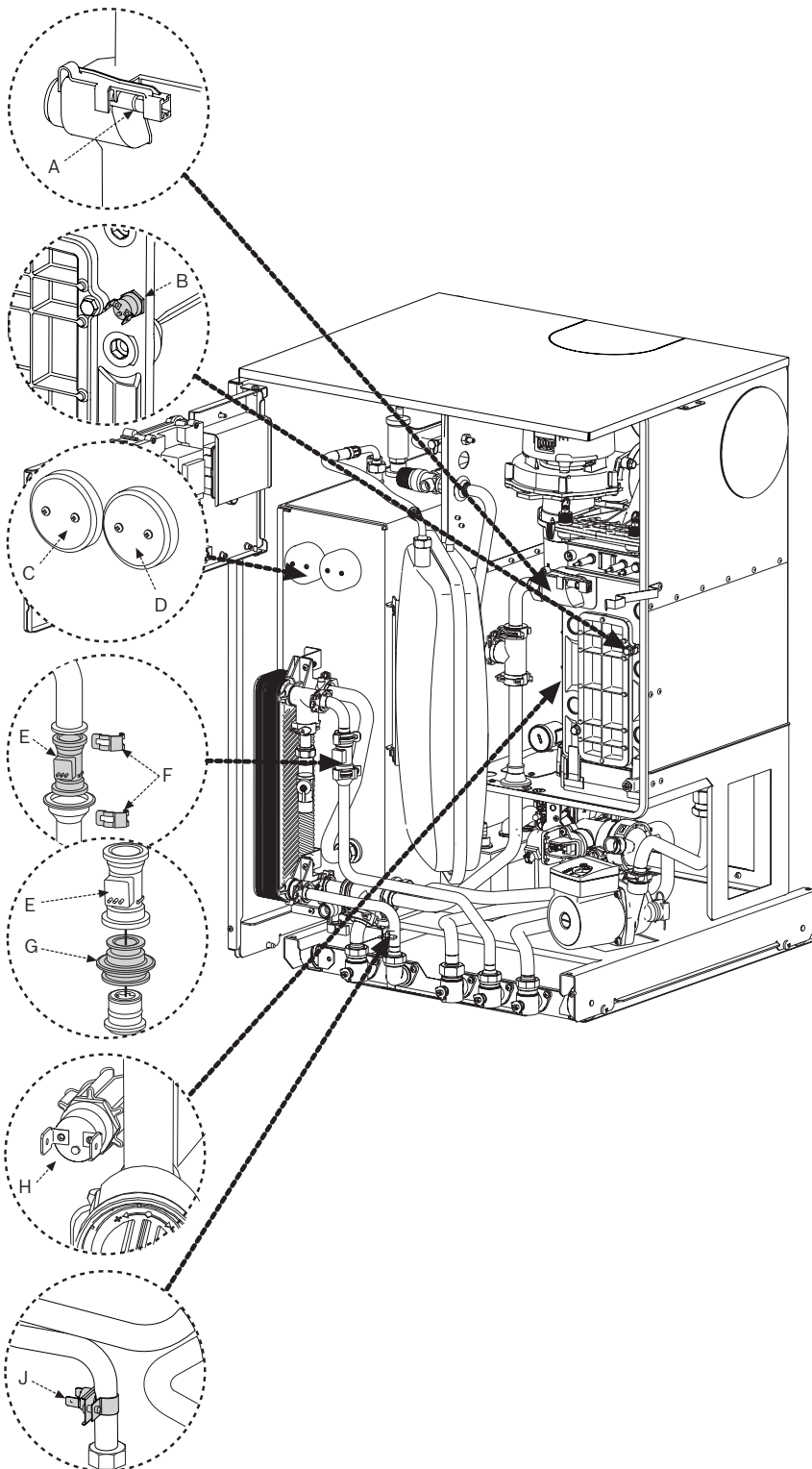

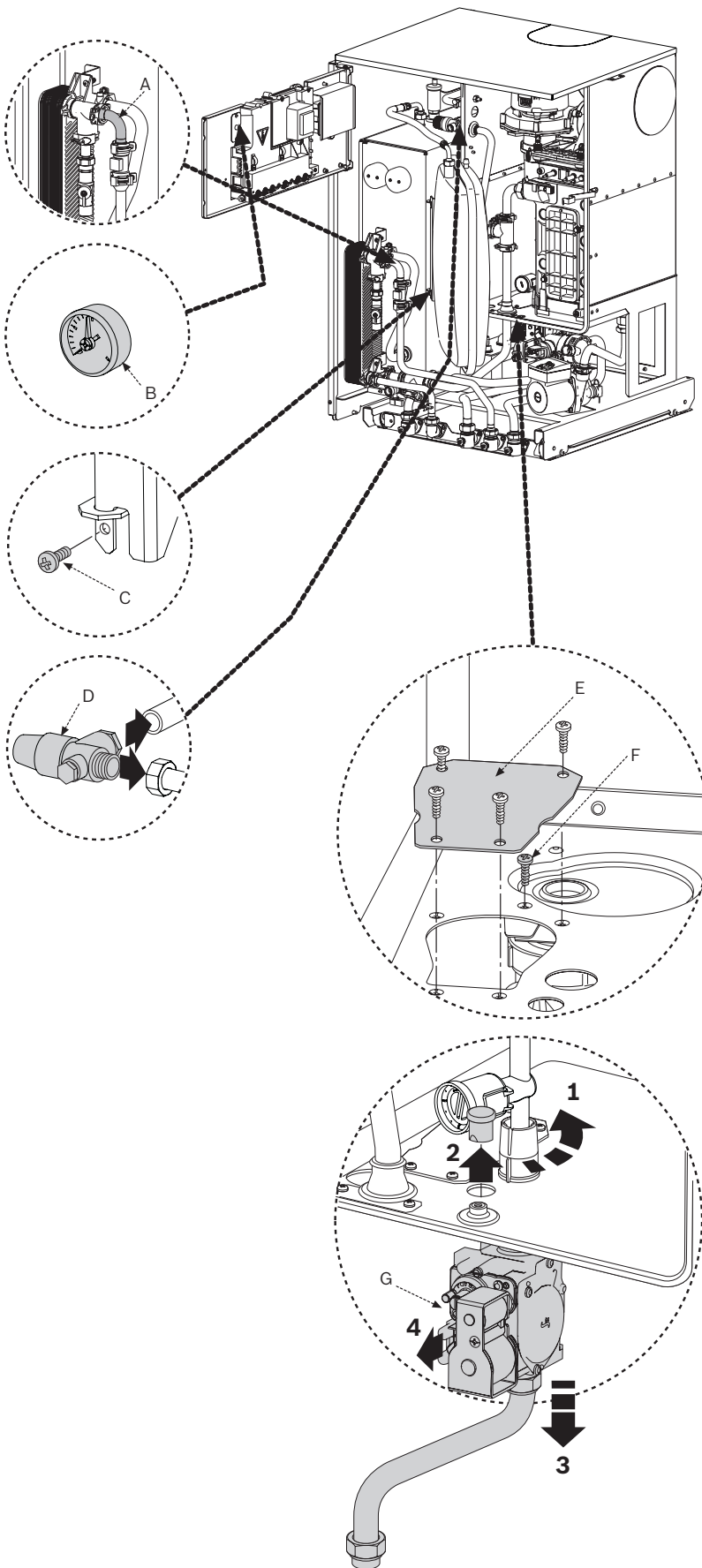

REPLACEMENT PARTS

Domestic hot water heat exchanger:

- ▶ Before removing the heat exchanger shut the inlet valves, drain the hot water circuits and tank.

The pipe (A) may be removed between the flow sensor outlet and the plate heat exchanger to improve access to the rear connections.

- ▶ Undo the two screws securing the plastic housing to the heat exchanger.
- ▶ Remove the heat exchanger.
- ▶ To refit, follow the above in reverse. Ensure any seals that have been disturbed are renewed.

Pressure gauge:

- ▶ Drain the appliance.
- ▶ Unscrew connection to the pressure relief valve.
- ▶ Remove 2 screws from rear of control panel and remove pressure gauge.
- ▶ Replace sealing washer and replace pressure gauge.

Expansion vessel:

- ▶ Drain the appliance.
- ▶ Move control panel into service position.
- ▶ Remove locking screw (C) from vessel bracket.
- ▶ Hinge pressure vessel out and lift from brackets.
- ▶ Undo the union connection at the top of the vessel.
- ▶ Set the pressure of the new vessel to that required by the system.

Pressure relief valve:

- ▶ Drain the appliance.
- ▶ Disconnect drain pipe from valve (D)
- ▶ Undo nut retaining valve to flow pipe.
- ▶ Undo nut connecting pressure gauge.
- ▶ Remove valve.
- ▶ Replace sealing washer and fit a new valve.

Condensate trap:

- ▶ Move control and pressure vessel into service position.
- ▶ Remove inner case door.
- ▶ Remove condensate pump.
- ▶ Remove access panel (E) at the base of the inner casing.
- ▶ Remove screw retaining trap (F) and push trap downwards until clear.
- ▶ Remove trap from boiler along with pipe to condensate pump.

Gas valve:

- ▶ Check that the gas cock is turned off.
- ▶ Remove condensate pump.

- ▶ Undo the union, within the inner casing, securing the valve to the gas/air tube.
- ▶ Remove the black rubber tube from the gas valve (G).
- ▶ Release the gas inlet union at the inlet.
- ▶ Remove the solenoid connections at the side of the gas valve.

▶ Transfer the inlet pipe assembly to the new gas valve.

▶ Check for gas soundness when the new gas valve has been fitted.

▶ After re-assembly check CO/CO₂ levels as described in the section "Setting the air/gas ratio".

REPLACEMENT PARTS

Electrode assembly:

- ▶ Switch off the master switch.
- ▶ Isolate appliance from the power supply.
- ▶ Move control panel into service position.
- ▶ Release 4 screws to remove inner case door.
- ▶ Remove the leads from the electrodes.
- ▶ Unscrew the two fixing screws (B) and carefully remove the electrode assembly (A).
- ▶ Replace and re-connect the assembly taking care not to mislay the inspection window.
- ▶ After re-assembly check CO/CO₂ levels as described in the section "Setting the air/gas ratio".

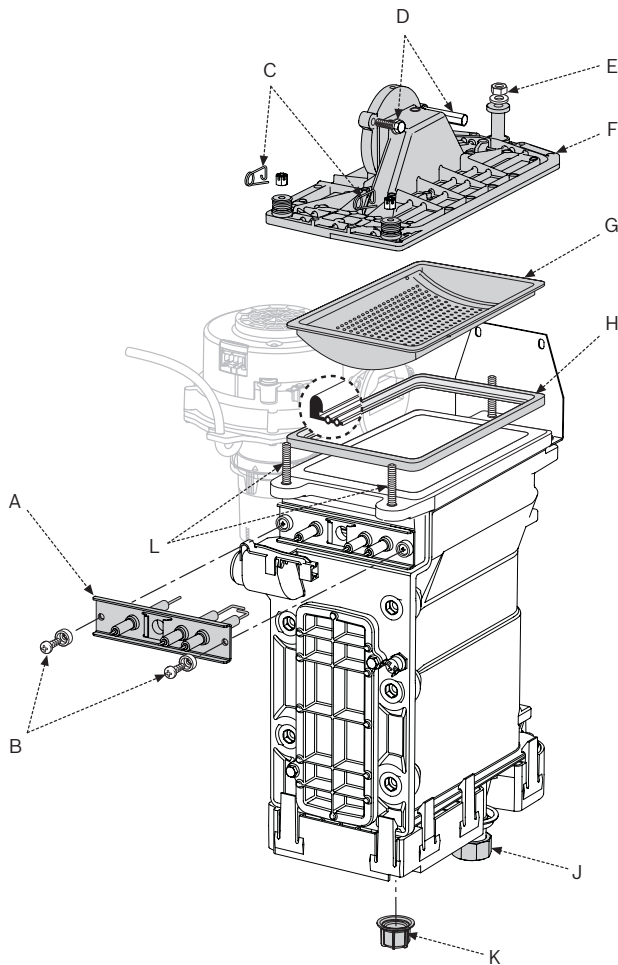

Burner:

- ▶ Check that the gas cock is turned off and the master switch is in the OFF position.
- ▶ Isolate appliance from the power supply.
- ▶ Remove the clips (C) and unscrew the two bolts (L).
- ▶ Remove springs.
- ▶ Unscrew and remove the 2 hexagon screws (D) securing the fan.
- ▶ Slacken fully the rear securing nut (E).
- ▶ Remove the burner coverplate (F).
- ▶ Remove the burner skin (G).
- ▶ Re-assemble the new burner in reverse order, inspect seal (H) for damage and replace if necessary.
- ▶ After re-assembly check CO/CO₂ levels as described in the section "Setting the air/gas ratio".

Primary heat exchanger:

- ▶ Isolate appliance from the power supply.
- ▶ Turn off all isolation valves.
- ▶ Drain down appliance.
- ▶ Move control and pressure vessel into service position. To improve access, remove the pressure vessel.
- ▶ Remove inner case door.
- ▶ Remove fan assembly, burner, gas mixing tube.
- ▶ Disconnect and remove sensors connected to heat exchanger.
- ▶ Remove condensate trap.
- ▶ Remove internal flue elbow and tube from boiler sump.
- ▶ Disconnect return pipe union (J) at the base of the boiler heat exchanger.
- ▶ Disconnect flow pipe connection.
- ▶ Remove plastic nut (K) from the base of the inner casing.
- ▶ Remove heat exchanger from inner casing.
- ▶ Ensure heat conductive paste is used on sensors when refitting.
- ▶ After re-assembly check CO/CO₂ levels as described in the section "Setting the air/gas ratio".

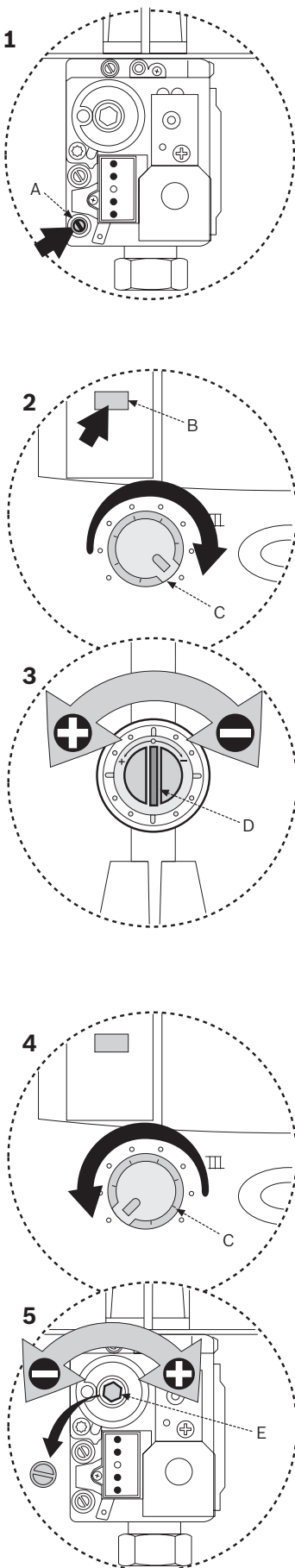

Greenstar Highflow 440CDi

GAS TYPE	CO ₂ setting maximum.	CO ₂ setting minimum.
Natural Gas Type H (G20)	9.4 ±0.5%	8.6 ±0.5%
LPG (propane) (G31)	10.8 ±0.5%	10.4 ±0.5%

Greenstar Highflow 550CDi

GAS TYPE	CO ₂ setting maximum.	CO ₂ setting minimum.
Natural Gas Type H (G20)	9.4 ±0.5%	9.0 ±0.5%
LPG (propane) (G31)	10.8 ±0.5%	10.4 ±0.5%

SETTING THE AIR/GAS RATIO

IMPORTANT: The appliance is set at the factory and adjustment to the CO₂ settings (air/gas ratio) is only required where the appliance has been stripped down and assembled or if the fan, burner or gas valve are replaced or the appliance has been converted to a different gas type.

The air/gas ratio may only be adjusted on the basis of a CO₂ measurement at maximum and minimum heat output using an electronic tester. Setting the gas ratio **MUST ONLY** be carried out by a competent person equipped with a combustion analyser conforming to BS 7927 and competent in its use.

- 1 ▶ Connect manometer to the inlet pressure point (A) on the gas valve.
- 2 To adjust the CO₂ it will be necessary to first operate the boiler at maximum output.
 - ▶ Press and hold down the boost button (B) for 10 seconds.
 - ▶ Turn temperature control (C) to maximum, the boiler will then go to maximum output.

Note: the control will resume normal operation after 15 minutes or if the boost button (B) is pressed for more than 1 second.
- 3 ▶ Remove plastic cap and using a flat bladed screwdriver, set the CO₂ via adjuster (D) referring the table opposite.

Note: CO₂ should be measured 10 minutes after firing the boiler.

 - ▶ Check the CO is less than 200ppm.
 - ▶ Measure the inlet pressure, it should be between 17 - 19mbar (nominally 18 mbar) for Natural Gas and between 35 - 39mbar (nominally 37mbar) for LPG.
- 4 ▶ Turn the temperature control (C) to minimum. This will make the boiler go to minimum output.
- 5 ▶ Measure the CO₂ it should now be at the figure for minimum output shown on the table opposite. If not, remove cap and adjust (E) on the gas valve until correct.
 - ▶ Check the CO is less than 200ppm.
 - ▶ Turn temperature control to maximum output and recheck the CO₂. If correct, hold down the boost button (B) for two seconds, the boiler should return to normal operating mode with the blue power indicator permanently illuminated.
 - ▶ Remove manometer and re-seal the inlet pressure point on the gas valve.
 - ▶ Fit a new plastic sealing cover to outlet adjuster (D) and replace the cap on the gas valve.
 - ▶ Remove red arrow from data plate and fit a new one in the correct position for gas type.

SHORT PARTS LIST

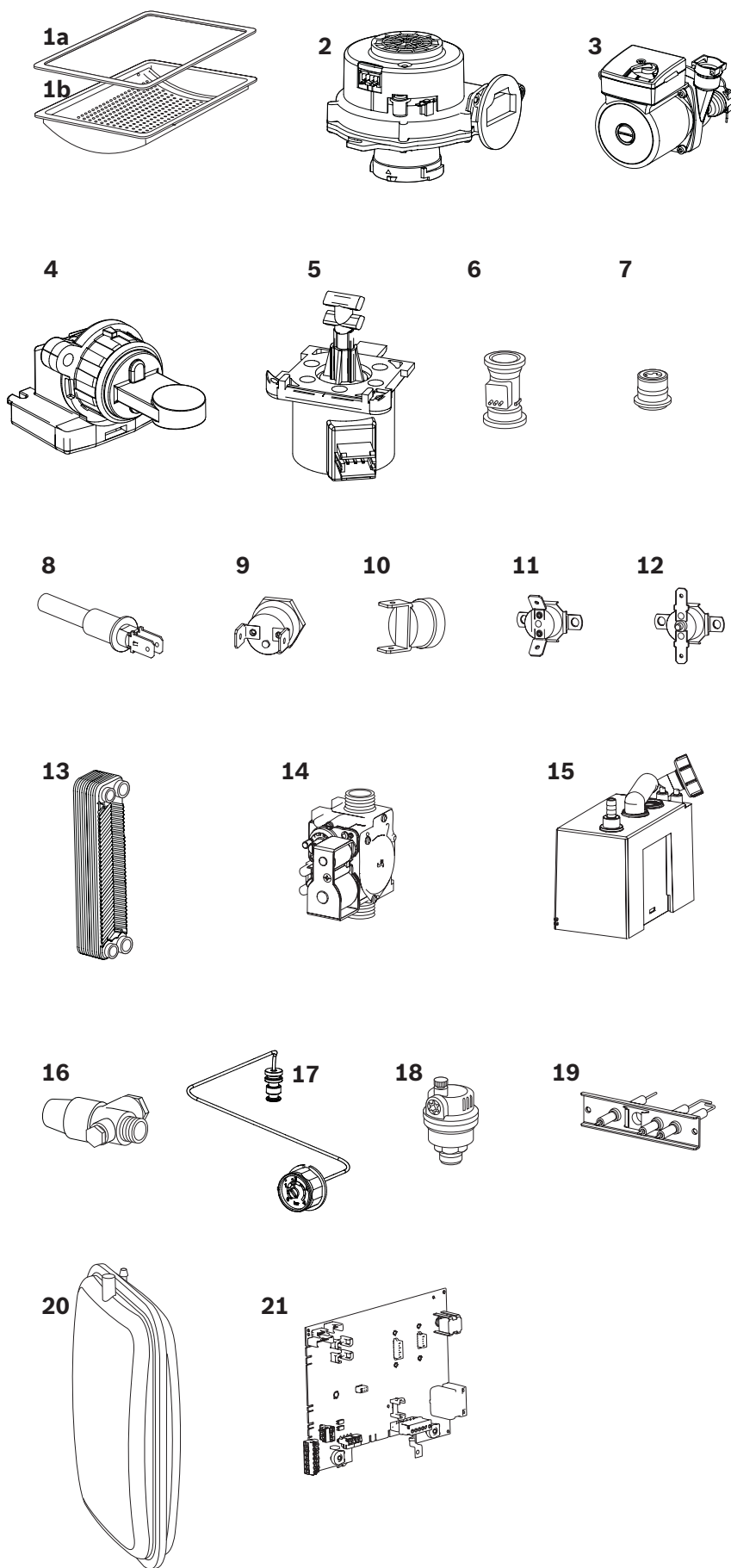

- 1a Burner skin seal:
Part No. 8 711 004 168 0 (GC No. E27 201)
- 1b Burner:
Part No. 8 718 006 658 0 (GC No. E27 200)
- 2 Fan assembly:
440CDi:
Part No. 8 717 204 410 0 (GC No. H66 918)
550CDi:
Part No. 8 717 204 543 0 (GC No. H26 536)
- 3 Circulating Pump assembly:
Part No. 8 718 681 477 0 (GC No. H66 929)
- 4 Diverter valve assembly:
Part No. 8 716 106 845 0 (GC No. H02 533)
- 5 Diverter valve motor:
Part No. 8 716 106 847 0 (GC No. H02 534)
- 6 Flow sensor:
Part No. 8 717 002 132 0 (GC No. H21 232)
- 7 Flow regulator:
440CDi Type E 20 litre Beige:
Part No. 8 717 002 135 0 (GC No. H21 235)
550CDi Type E 25 litre light grey:
Part No. 8 718 681 198 0 (GC No. H66 928)
- 8 Temperature sensor primary:
Part No. 8 714 500 087 0 (GC No. E74 536)
- 9 Temperature limit (Flue or heat exchanger):
Part No. 8 722 963 858 0 (GC No. H08 291)
- 10 Thermistor sensor (DHW):
Part No. 8 716 142 302 0 (GC No. 375 696)
- 11 Thermistor sensor (tank):
Part No. 8 716 142 319 0 (GC No. 379 785)
- 12 Overheat thermostat (Tank):
Part No. 8 716 103 217 0 (GC No. E82 394)
- 13 Heat exchanger:
440CDi:
Part No. 8 716 108 212 0 (GC No. H22 465)
550CDi:
Part No. 8 718 680 648 0 (GC No. H66 931)
- 14 Gas valve:
Part No. 8 718 221 347 0 (GC No. H56 469)
- 15 Condensing Pump:
Part No. 8 716 114 077 (GC No. H66 921)
- 16 Pressure relief valve:
Part No. 8 716 142 416 0 (GC No. 386 789)
- 17 Pressure gauge:
Part No. 8 718 680 742 0 (GC No. H66 930)
- 18 Auto air vent:
Part No. 8 716 140 500 0 (GC No. E00 717)
- 19 Electrodes:
Part No. 8 718 107 087 0 (GC No. E74 535)
- 20 Expansion vessel:
Part No. 8 715 407 288 0 (GC No. H21 242)
- 21 Control board:
Part No. 8 748 300 606 0 (GC No. H66 923)

L.P.G. CONVERSION

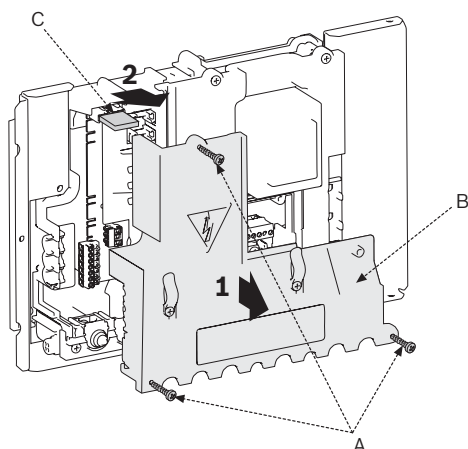

Change code plug:

- ▶ Release three screws (A) to remove cover (B).
- ▶ Remove and dispose of the existing code plug (C).
 - ▶ Replace with new conversion code plug.
 - N.G. code plug number:
 - 440CDi 1700
 - 550CDi 1702
 - L.P.G. code plug number:
 - 440CDi 1701
 - 550CDi 1703

Change gas pipe:

- ▶ Rotate gas pipe (D) anti-clockwise, pull upwards and remove gas pipe.
- ▶ Replace with new conversion gas pipe (E), push downwards and rotate clockwise to lock into position.

Conversion label:

- ▶ Replace existing label with new conversion label.

Adjust the CO₂ level:

- ▶ After re-assembly check CO/CO₂ levels as described in the section "Setting the air/gas ratio".

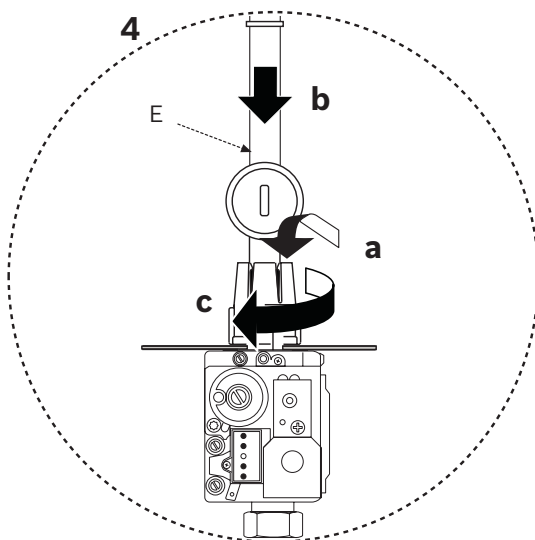
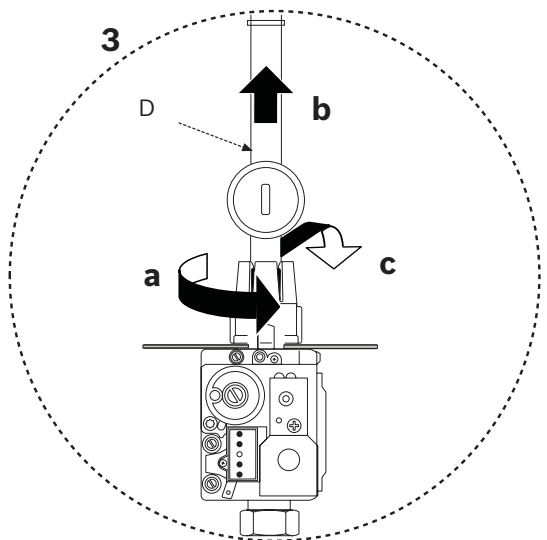

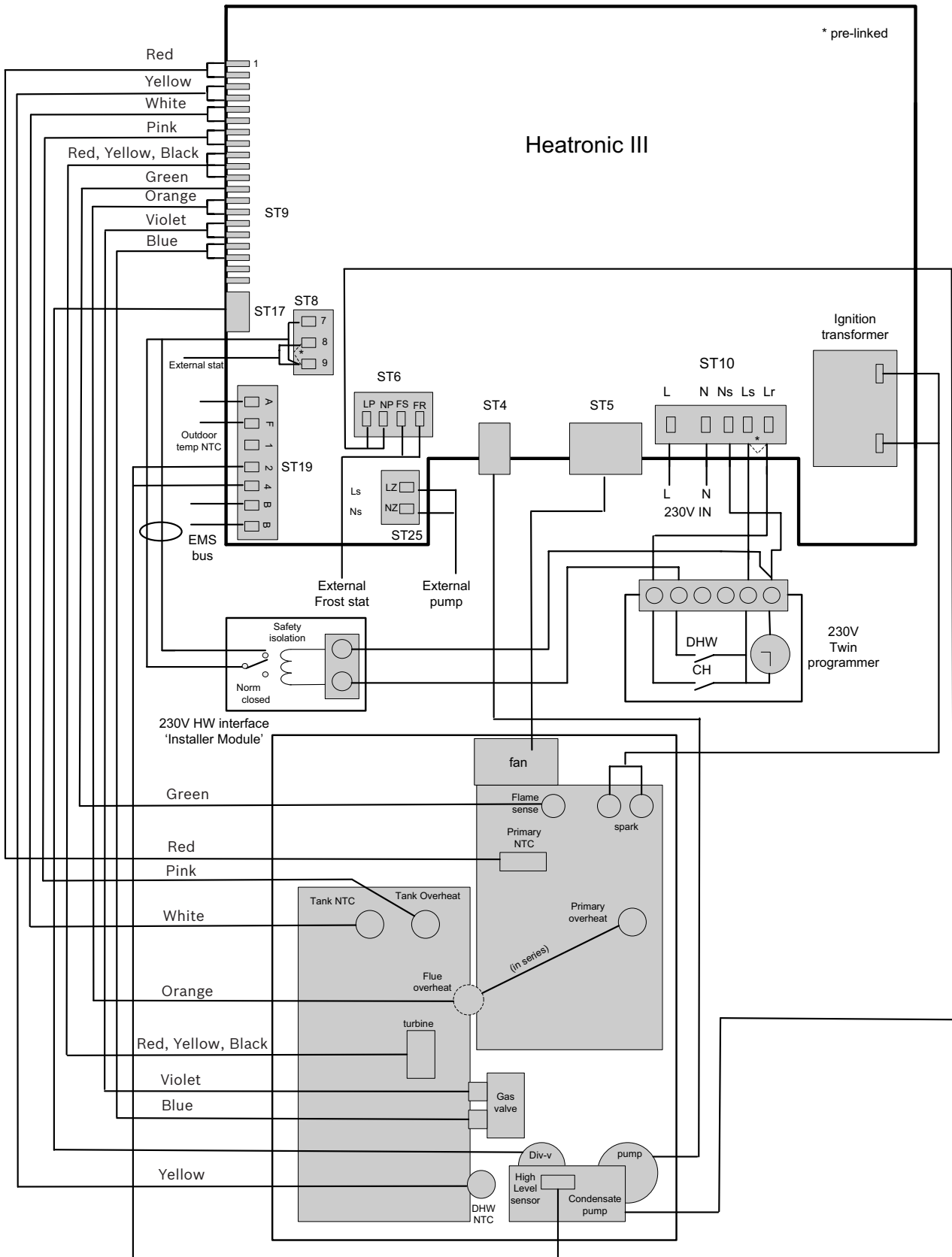

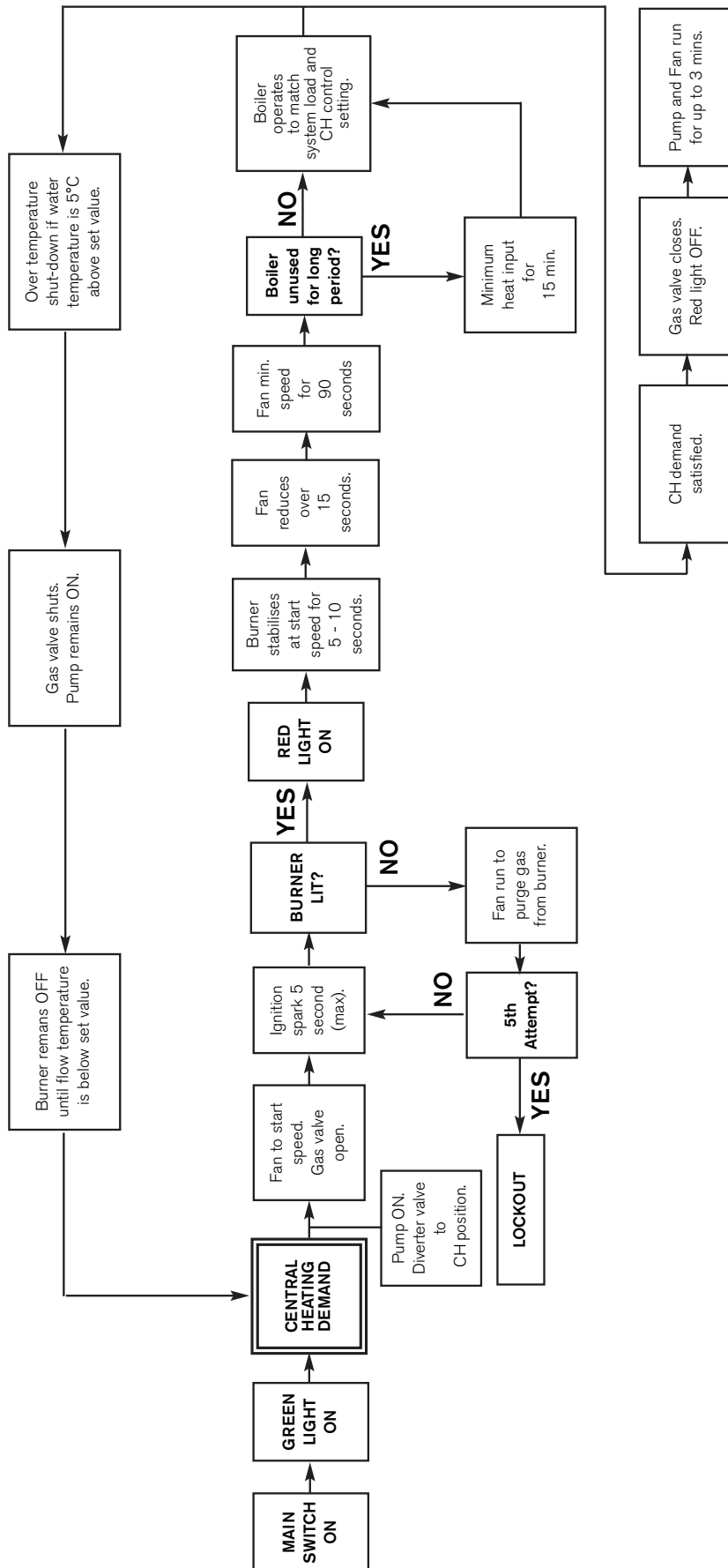

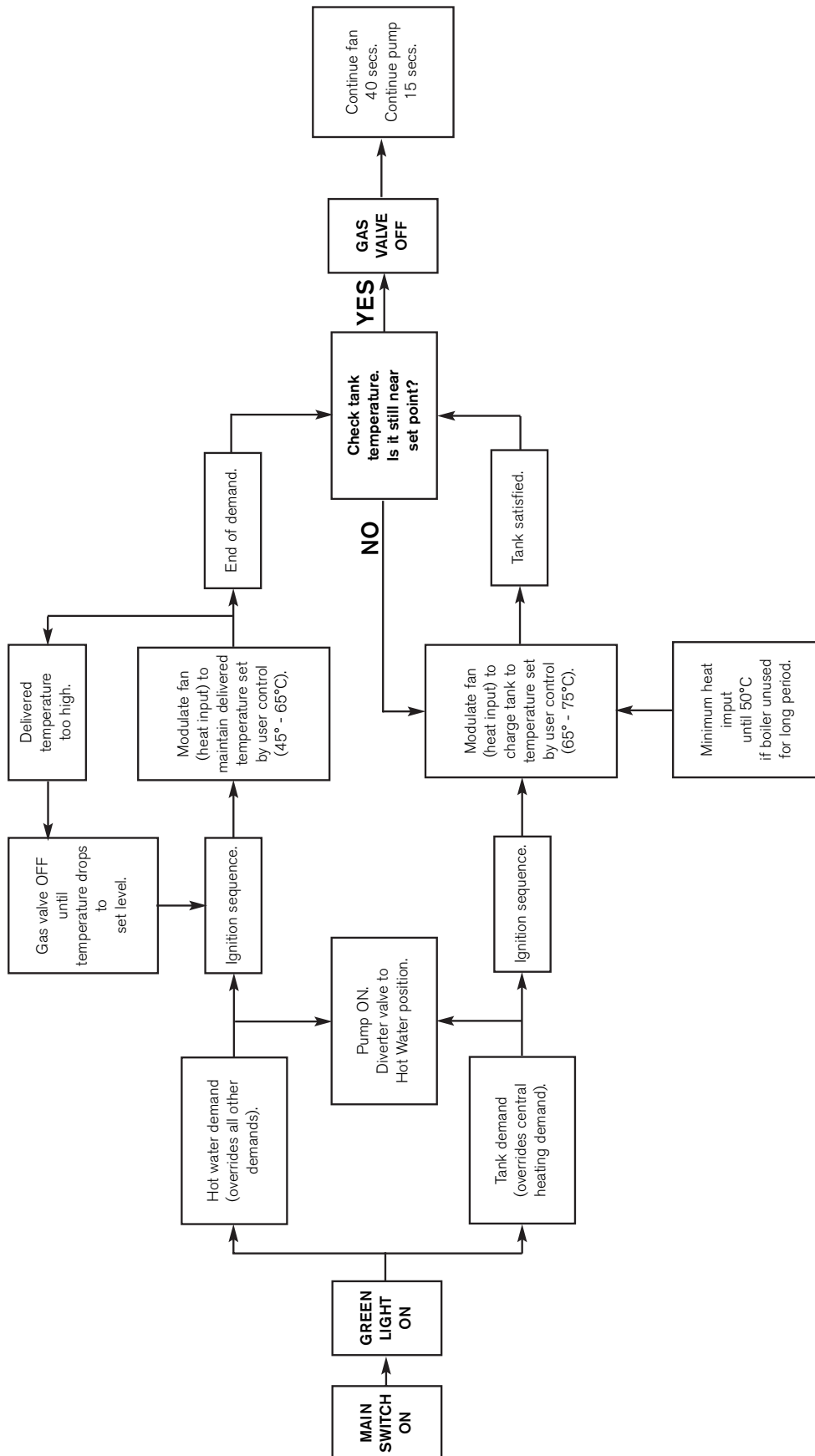

FAULT FINDING

NOTE ; This fault finding information is for guidance only. Worcester Bosch cannot be held responsible for costs incurred by persons not deemed to be competent.

The electronic control system for this boiler incorporates a blue central indicator. This normally confirms the permanent mains supply, but, by flashing during a fault, provides a guide to the cause as listed.

This fault finding system assumes that the appliance has been operating normally until the time of failure (i.e. not a first time installation error).

Preliminary checks:

Preliminary electrical system checks are the first electrical checks to be carried out during a fault finding procedure.

On completion of the Service/Fault finding task which has required the breaking and remaking of electrical connections, check:

- a) EARTH CONTINUITY
- b) SHORT CIRCUIT CHECK
- c) POLARITY
- d) RESISTANCE TO EARTH.

BOILER - FAULT CODES AND CONDITIONS		
Display Code:	Fault description:	Check, repair/replace as necessary:
A5	Tank NTC defect	check tank NTC and leads
A7	DHW NTC defect	check hot water NTC and connecting lead
A8	EMS coms error	check electrical connections.
b1	Code plug not detected	Insert code plug correctly.
b2, b3, b4 b5, b6	Data error	software/pcb error.
b7	Burner control error	software/pcb error.
C6	Fan defect	check fan, lead and connector.
D3	External Temp limiter	check external stat.
D5	Condensate overflow	check condensate pump and leads.
D6	Internal heatbank overheated	check tank overheat thermostat
EA	Burner control lockout	check gas supply and igniter electrode.
E2	Primary NTC defect	check CH NTC and lead.
E9	OH stat tripped	check system pressure and pump.
F0	Internal error	check electrical connector contacts.
F1	Rom check error	software/pcb error.
F7	Flame detected after appliance shut off	check electrode assembly, dry pcb.
FA	Flame detected after gas shut off	check gas valve and leads.
Fd	Reset button pressed	press reset button again.

CONDENSATE PUMP - OPERATING LAMPS AND FAULT CONDITIONS

Ready for operation = Steady green light
 Fault = Red light
 Pump running = Flashing green light

Operating lamps		Cause	Solution
Green	Red		
Off	Off	Mains plug not plugged in Power failure	Insert plug Check mains and fuse
Flashing	Flashing	Dry-run (poss. air in pump)	Pump restarts automatically after one minute
On	Flashing	Pump blocked	Visual inspection of the pump inlet in the tank and removal or rinsing out of dirt/foreign bodies
On	On	Level exceeds alarm level	Pressure hose / non-return valve blocked (clean or remove kink if applicable)
Off	Flashing	Pump blocked and alarm level exceeded	Visual inspection of the pump inlet in the tank and removal or rinsing out of dirt/foreign bodies

SERVICE RECORD

It is recommended that your heating system is serviced regularly and that the appropriate Service Record is completed.

Service Provider

Before completing the appropriate Service Record below, please ensure you have carried out the service as described in the manufacturer's instructions.

Always use the manufacturer's specified spare part when replacing controls.

SERVICE 1 Date _____

Energy Efficiency Checklist completed? Yes No

Engineer Name _____

Company Name _____

Telephone Number _____

CORGI ID Number _____

Comments _____

Signature _____

SERVICE 2 Date _____

Energy Efficiency Checklist completed? Yes No

Engineer Name _____

Company Name _____

Telephone Number _____

CORGI ID Number _____

Comments _____

Signature _____

SERVICE 3 Date _____

Energy Efficiency Checklist completed? Yes No

Engineer Name _____

Company Name _____

Telephone Number _____

CORGI ID Number _____

Comments _____

Signature _____

SERVICE 4 Date _____

Energy Efficiency Checklist completed? Yes No

Engineer Name _____

Company Name _____

Telephone Number _____

CORGI ID Number _____

Comments _____

Signature _____

SERVICE 5 Date _____

Energy Efficiency Checklist completed? Yes No

Engineer Name _____

Company Name _____

Telephone Number _____

CORGI ID Number _____

Comments _____

Signature _____

SERVICE 6 Date _____

Energy Efficiency Checklist completed? Yes No

Engineer Name _____

Company Name _____

Telephone Number _____

CORGI ID Number _____

Comments _____

Signature _____

SERVICE 7 Date _____

Energy Efficiency Checklist completed? Yes No

Engineer Name _____

Company Name _____

Telephone Number _____

CORGI ID Number _____

Comments _____

Signature _____

SERVICE 8 Date _____

Energy Efficiency Checklist completed? Yes No

Engineer Name _____

Company Name _____

Telephone Number _____

CORGI ID Number _____

Comments _____

Signature _____

SERVICE 9 Date _____

Energy Efficiency Checklist completed? Yes No

Engineer Name _____

Company Name _____

Telephone Number _____

CORGI ID Number _____

Comments _____

Signature _____

SERVICE 10 Date _____

Energy Efficiency Checklist completed? Yes No

Engineer Name _____

Company Name _____

Telephone Number _____

CORGI ID Number _____

Comments _____

Signature _____

Dedicated to heating comfort

Worcester, Bosch Group

Cotswold Way, Warndon, Worcester WR4 9SW

Tel. 01905 754624 Fax. 01905 754619

Worcester, Bosch Group is a brand name of Bosch Thermotechnology Ltd.

worcester-bosch.co.uk

8 716 115 219b (09.2008)

