

Installation, Commissioning and Servicing instructions

Floor standing oil fired condensing combination boiler balanced flue

Greenstar Heatslave II External ^{ErP} 12/18, 18/25 & 25/32

For fully pumped open vent or sealed central heating systems and domestic hot water cylinders.
These appliances are for use with Kerosene (Class C2) only.

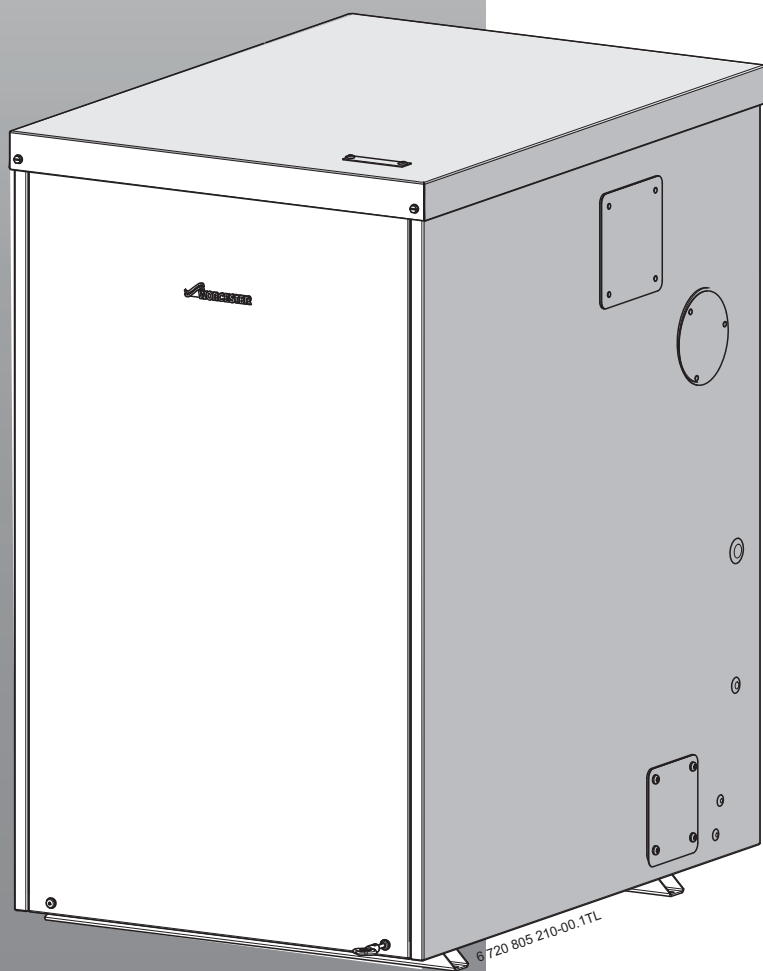

Contents

1	Key to symbols and safety instructions	3	7	Service and Spares	32
1.1	Key to symbols	3	7.1	Inspection and service	32
1.2	General safety instructions	3	7.2	Short parts lists 12/18	37
			7.3	Short parts lists 18/25	38
			7.4	Short parts lists 25/32	39
2	Installation regulations	4			
2.1	Complying with the building regulations	4			
3	Appliance information	5	8	Fault finding and diagnosis	40
3.1	General information	5	8.1	Status cause codes	40
3.2	Technical data	5	8.2	Information menu	40
3.3	Energy efficiency	6	8.3	Service menus	41
3.4	Layout & components	7	8.4	Factory reset and fault codes	42
			8.4.1	Factory reset	42
			8.4.2	Locking or Blocking fault conditions	42
			8.4.3	Cause and fault codes	43
4	Pre-Installation	8	8.5	DHW function chart	44
4.1	Cleaning primary systems	8	8.6	CH function chart	45
4.2	Mains supply	9	8.7	Protection functions	45
4.2.1	Electrical supply	9	8.8	Solar compatibility	46
4.2.2	Water supply	9	8.9	Burner diagnostics mode	47
4.2.3	Oil supply	9	8.10	Riello digital control boxes	48
4.2.4	Pipework	10	8.11	Oil supply vacuum testing	50
4.2.5	Boiler isolation valve	11			
4.3	Water systems and pipework	11			
4.4	Condensate pipework	12			
4.4.1	Condensate disposal connections	12			
4.4.2	Soak away	13			
4.5	Pressure relief pipework	14			
4.6	Boiler locations and clearances	14			
4.7	Flue terminal positions	15			
4.8	Flue options	16			
4.8.1	Cabinet mounted balanced horizontal flue options	16			
4.8.2	Plume management	16			
5	Installation	17			
5.1	Unpacking the boiler	17			
5.2	Pipework and flue positions	17			
5.3	Boiler installation	18			
5.4	Flue installation	18			
5.5	Combustion chamber	18			
5.6	Pipework connections	19			
5.7	Oil burner and pump	20			
5.8	Refitting components	21			
5.9	Electrical	21			
5.10	Electrical schematic	23			
5.11	Weather compensation	24			
6	Commissioning	25			
6.1	Pre-commissioning checks-appliance	25			
6.2	Filling the system	25			
6.3	Starting the appliance	26			
6.4	Water treatment	31			
6.5	Finishing commissioning - Appliance	32			

1 Key to symbols and safety instructions

1.1 Key to symbols

Warnings

	Warnings in this document are identified by a warning triangle printed against a grey background. Keywords at the start of a warning indicate the type and seriousness of the ensuing risk if measures to prevent the risk are not taken.
---	---

The following keywords are defined and can be used in this document:

- **NOTICE** indicates a situation that could result in damage to property or equipment.
- **CAUTION** indicates a situation that could result in minor to medium injury.
- **WARNING** indicates a situation that could result in severe injury or death.
- **DANGER** indicates a situation that will result in severe injury or death.

Important information

	This symbol indicates important information where there is no risk to people or property.
---	---

Additional symbols

Symbol	Explanation
▶	Steps in an action sequence
→	Cross-reference to another part of the document
•	List entry
–	List entry (second level)

Table 1

Abbreviations used in this manual

∅	Diameter
CH	Central Heating
DHW	Domestic Hot Water
DCW	Domestic Cold water
TRV	Thermostatic Radiator Valve
IP	Ingress Protection
CF	Conventional Flue
RS	Room Sealed
N/A	Not Applicable
SEDBUK	Seasonal Efficiency of Domestic Boilers in the UK
OFTEC	Oil Firing Technical Association for the Petroleum Industry
IET	Institution of Engineering and Technology
DWTA	Domestic Water Treatment Association
LABC	Local Authority Building Control Body

Table 2

Read these instructions before starting any installation

These instructions are applicable to the Worcester appliance model(s) stated on the front cover of this manual only and must not be used with any other make or model of appliance.

The instructions apply in the UK and Eire only and must be followed except for any statutory obligation.

This appliance must be installed by a competent person, failure to install correctly could lead to prosecution.

1.2 General safety instructions

These installation instructions are intended for heating engineers, plumbers, and electricians.

- ▶ Read any installation instructions (boiler, heating controls, etc.) carefully before starting the installation.
- ▶ Observe the safety instructions and warnings.
- ▶ Observe national and regional regulations, technical rules and guidelines.
- ▶ Record all work carried out.

Oil fumes or leaks from the appliance

If you smell oil fumes, observe the following rules.

- ▶ Extinguish any naked flames
- ▶ Isolate the electrical supply
- ▶ Isolate the fuel supply to the boiler
- ▶ Rectify the fault

Health and safety

The appliance contains no asbestos and no substances have been used in the construction process that contravene the COSHH Regulations (Control of Substances Hazardous to Health Regulations 1988). Where applicable, the CE mark indicates compliance with relative EU Directives.

Combustible and corrosive materials

Do not store or use any combustible materials (paper, thinners, paints etc.) inside or within the vicinity of the appliance.

The combustion air must be kept clear of chemically aggressive substances which can corrode the appliance and invalidate any warranty.

Handling instructions and guidelines

It is advised that more than one person is involved in the transfer of the packaged appliance from the van to the point of installation.

It is advised that no attempt should be made to move the packaged appliance without the use of a suitable truck.

At all times the correct method for handling heavy objects should be strictly observed.

- ▶ Lift only a manageable weight, or ask for help.
- ▶ When lifting, bend the knees, and keep the back straight and feet apart.
- ▶ Do not lift and twist at the same time.
- ▶ Lift and carry items close to the body.
- ▶ Wear protective clothing and gloves to protect from any sharp edges.

Intended use

This boiler must only be used as a heat appliance in a heating system for domestic purposes.

Any other use is considered inappropriate. Any damage that results from such use is excluded from liability.

This boiler must only be operated by a responsible adult who has been instructed in, understands and is aware of the boiler's operating conditions and effects.

Installation, commissioning and servicing

Installation, commissioning and servicing must only be carried out by a competent registered engineer.

- ▶ Only use original spares.
- ▶ Advise the user to have the system regularly serviced by a competent, qualified engineer (such as OFTEC registered personnel) using approved spares, to help maintain the economy, safety and reliability of the appliance.

Fitting and Modification

Fitting the appliance and any controls to the appliance may only be carried out by a competent engineer in accordance with these instructions and the relevant Installation Regulations.

Flue systems must not be modified in any way other than as described in the fitting instructions.

Any misuse or unauthorised modifications to the appliance, flue or associated components and systems could invalidate the warranty. The manufacturer accepts no liability arising from any such actions, excluding statutory rights.

Electrical work

Electrical work must only be carried out by a qualified electrician.

- ▶ Before starting electrical work:
 - Isolate the mains electrical supply and secure against unintentional re-connection.
 - Check for zero potential.
- ▶ Also observe connection diagrams of other system components.

Handover to the user

When handing over, instruct the user how to operate the heating system and inform him about its operating conditions.

- ▶ Explain how to operate the heating system and draw the user's attention to any safety-relevant action.
- ▶ Explain that modifications and repairs must only be carried out by an authorised contractor.
- ▶ Advise the user to have the system serviced annually by a competent, qualified engineer, such as an OFTEC registered engineer.
- ▶ Leave the installation instructions with the completed commissioning form with the homeowner.

operation the appliance must be commissioned by a qualified OFTEC engineer.

The compliance with a British Standard does not, in itself, confer immunity from legal obligations. In particular the installation of this appliance must be in accordance with the relevant requirements of the following British Standards and regulations in respect of the safe installation of equipment:

BS 5410: part 1:	Code of practice for Oil Fired Boilers.
BS 799: part 5:	Specification for Oil Storage Tanks
BS 7593:	Code of Practice for treatment of water in domestic hot water central heating systems.
BS 5449: part 1:	Specification for forced circulation hot water central heating for domestic premises.
BS EN 12828: 2012 +A1: 2014	Heating systems in buildings. Design for water-based heating systems
BS 7291:	Thermoplastic pipes and associated fittings for hot and cold water for domestic purposes and heating installations in buildings
BS 7074: part 1:	Application, selection and installation of expansion vessels and ancillary equipment for sealed water systems.
BS 1254-2:	Copper and copper alloys plumbing fittings part 2: Fittings with compression ends for use with copper tubes.
BS 7671:	IET Wiring Regulations, current edition.
BS 1362:	Specification for general purpose fuse links for domestic and similar purposes.

The Building Regulations Part G, Part J and L1 England and Wales; Part F, Part G and Part J Section III Scotland; Part L and Part F Northern Ireland.

Local water company bye-laws.

The Control of Pollution (Oil) Regulations.

OFTEC Standards.

Where no specific instruction is given, reference should be made to the relevant codes of practice.

Installations in Eire (Republic of Ireland)

The Installation must be performed by a competent and suitably trained person in accordance with the following Eire regulations.

Current Building Regulations - Republic of Ireland

ETCI rules for electrical installation

For further guidance see

OFTEC Technical book three - Regional requirements: Republic of Ireland

2 Installation regulations

2.1 Complying with the building regulations

This heating appliance forms part of the controlled services for the building. It is law that all controlled services for buildings must comply with building regulations. You must be able to satisfy your Local Authority Building Control Body (LABC) that the work carried out concerning the installation and commissioning of this heating appliance has been carried out to a satisfactory standard.

OFTEC operate a competent persons scheme and registered installers are able to certify that their work complies with building regulations. Under the scheme;

- OFTEC must be informed about every installation.
- OFTEC will issue a building regulations compliance certificate to the householder and will notify the LABC.

OFTEC provide controlled document forms CD10 and CD11 for use during installation and commissioning respectively.

Other organisations operate self-certification schemes e.g. NAPIT and BESCA Ltd. and it may be possible for installers who are members of these organisations to self certify their work.

Alternatively you must submit a building control notice to the LABC before installing any boiler. The LABC will then arrange regular inspection visits during the work to ensure that the installation complies with the regulations.

Installation

Failure to install appliances correctly could lead to prosecution.

The appliance should be installed by a competent person. The person installing the appliance should be aware of the Health and Safety at Work Act and take appropriate action to ensure that the regulations are adhered to. In order to give optimum efficiency and trouble free

3 Appliance information

3.1 General information

Standard package

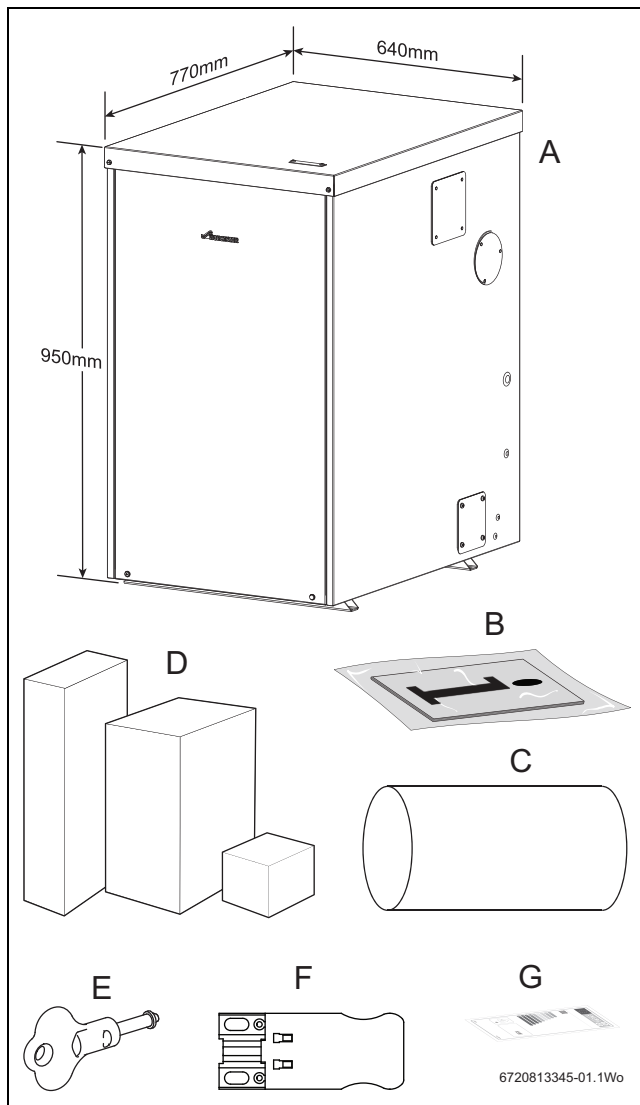

Fig. 1 Standard package

- [A] Floor standing oil fired condensing combination boiler for sealed central heating and mains fed domestic hot water.
- [B] Literature pack
- [C] 100mm Ø services duct.
- [D] Balanced flue kit
- [E] Cabinet key
- [F] Mains supply socket
- [F] ErP label

Check List (Literature pack)

Item	Qty
Greenstar Heatslave II External Installation/ Servicing Instructions	1
Instructions	1
Hardware Pack	1

3.2 Technical data

Description	Units	12/18	18/25	25/32
Central heating				
Primary water capacity (total)	litres	62	63	64
Available pump head (20°C difference) at max. output	metres water	4.7	4.0	4.2
Max. permissible system operating pressure in accordance with WRAS guidelines	bar	2.5	2.5	2.5
Flow restrictor	colour	Lime	Beige	Grey
Domestic Hot Water				
Maximum flow rate (± 15%)	litres/min	15	18	22
Minimum inlet pressure (dynamic) for maximum flow rate	bar	1.5	1.2	1.6
Maximum hot water temperature rise for 90 litres draw off (@max flow rate)	°C	40	40	40
Flue				
Exit flue gas mass flow	kg/hr	29	40	51
Pipework connections				
Fuel line (compression)	mm	10	10	10
CH flow	mm	22	22	28
CH return	mm	22	22	28
Water main inlet	mm	15	15	15
DHW outlet	mm	22	22	22
CH drain	hose connection			
Condensate (polypropylene)	mm	21.5	21.5	21.5
Electrical				
Electrical power supply voltage	AC...V	230	230	230
Frequency	Hz	50	50	50
Sensors & Thermostats				
CH control range	°C	50/82	50/82	50/82
Slave tank control range	°C	55/84	55/86	55/88
Boiler manual reset overheat set point	°C	105	105	105
Flue manual reset overheat thermostat set point	°C	110	110	110
Tank manual reset overheat thermostat set point	°C	95	95	95
General data				
Maximum hearth temperature	°C	<100	<100	<100
SEDBUK 2009	%	89.4	89.2	89.0
SEDBUK 2005	%	90.4	90.2	90.0
Appliance protection rating	IP	45	45	45
Weight (excluding packaging)	kg	151	154	158

3.3 Energy efficiency

The following product data satisfy the requirements of the EU Regulations No. 811/2013 and No. 812/2013 supplementing Directive 2010/30/EU.

Product data	Symbol	Unit	7731600050	7731600051	7731600052
Product type	–	–	Greenstar Heatslave II External ^{ErP} 12/18	Greenstar Heatslave II External ^{ErP} 18/25	Greenstar Heatslave II External ^{ErP} 25/32
Condensing boiler	–	–	Yes	Yes	Yes
Low temperature boiler	–	–	No	No	No
B1 boiler	–	–	No	No	No
Cogeneration space heater (CHP)	–	–	No	No	No
Combination heater	–	–	Yes	Yes	Yes
Rated heat output	P_{rated}	kW	18	25	32
Seasonal space heating energy efficiency	η_s	%	91	90	91
Energy efficiency class	–	–	A	A	A
Useful heat output					
At rated heat output and high temperature regime ¹⁾	P_4	kW	17.9	24.9	32.2
At 30 % of rated heat output and low temperature regime ²⁾	P_1	kW	5.7	7.9	10.2
Useful efficiency					
At rated heat output and high temperature regime ¹⁾	η_4	%	91.1	90.9	91.4
At 30 % of rated heat output and low temperature regime ²⁾	η_1	%	96.8	95.8	96
Auxiliary electricity consumption					
At full load	e_{lmax}	kW	0.136	0.161	0.163
At part load	e_{lmin}	kW	0.044	0.047	0.048
In standby mode	P_{SB}	kW	0.002	0.002	0.002
Other items					
Standby heat loss	P_{stby}	kW	0.123	0.160	0.160
Ignition burner power consumption	P_{ign}	kW	0	0	0
Emissions of nitrogen oxides	NOx	mg/kWh	243	193	136
Annual energy consumption	Q_{HE}	kWh	-	-	-
Sound power level, indoors	L_{WA}	dB(A)	N/A	N/A	N/A
Additional data for combination heaters					
Declared load profile	–	–	XL	XL	XL
Daily electricity consumption	Q_{elec}	kWh	0.458	0.353	0.361
Annual electricity consumption	AEC	kWh	101	78	80
Daily fuel consumption	Q_{fuel}	kWh	29,030	27,979	28,686
Annual fuel consumption	AFC	GJ	1.774	1.710	1.753
Water heating energy efficiency	η_{wh}	%	68	71	70
Water heating energy efficiency class	–	–	B	B	B

Table 3 Product data for energy consumption

- 1) High temperature regime means 60 °C return temperature at heater inlet and 80 °C feed temperature at heater outlet.
- 2) Low temperature means for condensing boilers 30 °C, for low-temperature boilers 37 °C and for other heaters 50 °C return temperature (at heater inlet).

3.4 Layout & components

The diagram below excludes the top, front and RH side casing panels.

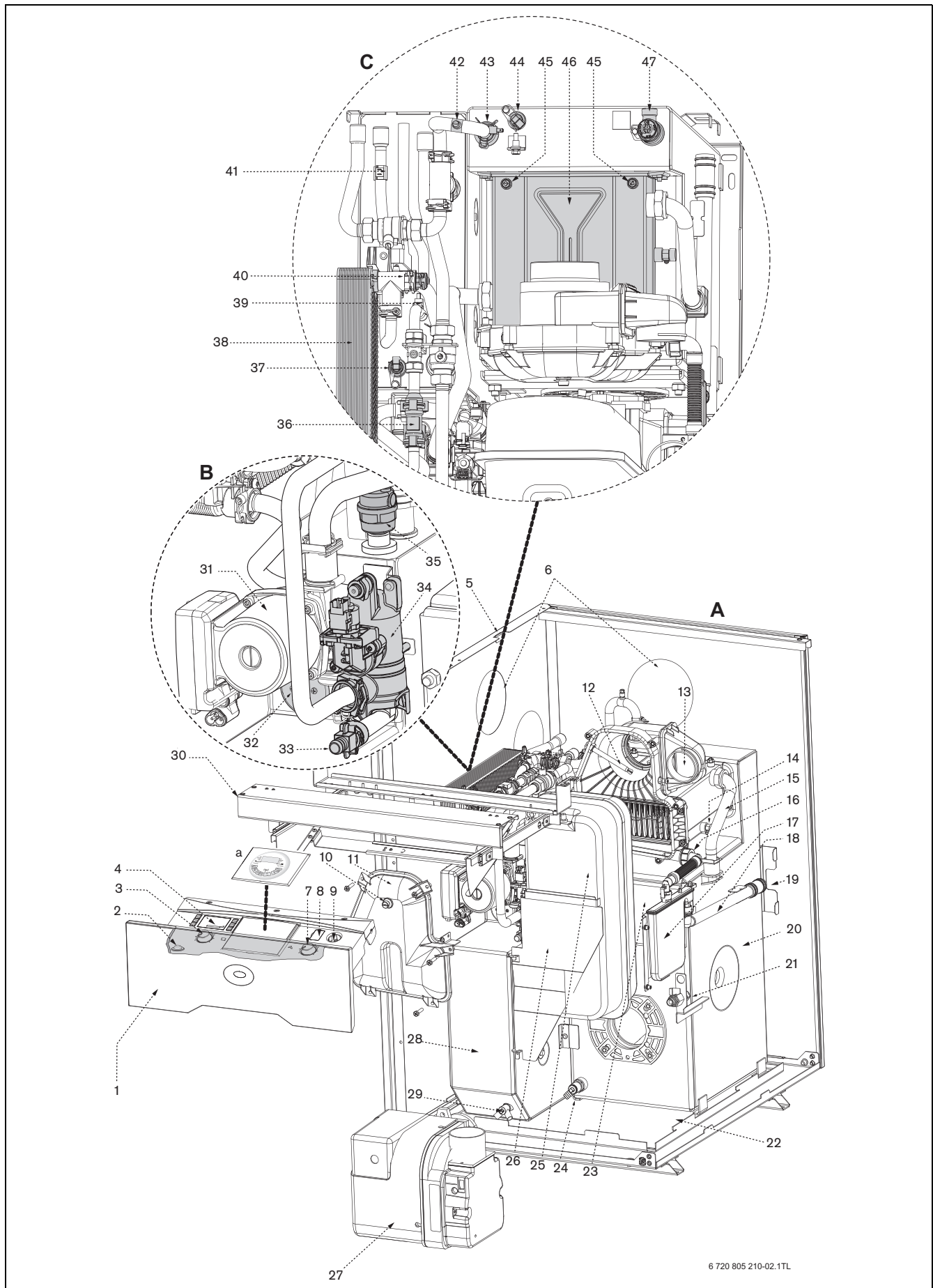

Fig. 2

Legend:

- A:**
- [1] CONTROL BOX ASSEMBLY
 - [2] SERVICE MODE BUTTON
 - [3] CH TEMPERATURE CONTROL KNOB
 - [4] LCD DISPLAY
 - [5] CASING SIDE PANEL
 - [6] FLUE OPENING SECTION
 - [7] TANK TEMPERATURE CONTROL KNOB
 - [8] DIAGNOSIS PORT - WORCESTER ENGINEER
 - [9] SYSTEM PRESSURE GAUGE
 - [10] FLUE GAS SAMPLING POINT
 - [11] FLUE MANIFOLD COVER
 - [12] FLUE OVERHEAT THERMOSTAT PHIAL
 - [13] AIR INLET CASING FLEXIBLE AIR DUCT (CONNECTING TO AIR INTAKE ON BURNER)
 - [14] SECONDARY HEAT EXCHANGER DRAIN
 - [15] HEAT EXCHANGER FLOW PIPE
 - [16] CONDENSATE OUTLET
 - [17] CONDENSATE TRAP
 - [18] CONDENSATE DRAIN PIPE
 - [19] FLEXIBLE CONDENSATE DRAIN PIPE CONNECTION
 - [20] PRIMARY HEAT EXCHANGER
 - [21] OIL ISOLATING VALVE
 - [22] BASE PLATE AND OIL DRIP TRAY
 - [23] COMBUSTION CHAMBER ACCESS DOOR AND ONE PIECE BAFFLE SET LOCATION
 - [24] PRIMARY HEAT EXCHANGER DRAIN
 - [25] EXPANSION VESSEL
 - [26] EXPANSION VESSEL BRACKET
 - [27] RIELLO RDB 2.2 BURNER
 - [28] HEATSLAVE TANK
 - [29] HEATSLAVE TANK DRAIN
 - [30] CASING BRACE AND CONTROL BOX SUPPORT
 - [a] OPTIONAL FASCIA MOUNTED PROGRAMMERS AVAILABLE (not supplied with the appliance or recommended for external appliances)
- B:**
- [31] CIRCULATING PUMP
 - [32] MANUAL RESET TANK OVERHEAT THERMOSTAT
 - [33] DRAIN POINT
 - [34] DIVERTER VALVE ASSEMBLY
 - [35] AUTOMATIC AIR VENT
- C:**
- [36] DHW FLOW TURBINE
 - [37] TANK TEMPERATURE SENSOR (NTC)
 - [38] DHW HEAT EXCHANGER
 - [39] MAINS INLET TEMPERATURE SENSOR (NTC)
 - [40] DHW PRESSURE RELIEF VALVE
 - [41] DHW TEMPERATURE SENSOR (NTC)
 - [42] PRIMARY MANUAL AIR VENT
 - [43] FLOW TEMPERATURE SENSOR (NTC)
 - [44] PRIMARY HEAT EXCHANGER SAFETY SENSOR (NTC)
 - [45] SECONDARY HEAT EXCHANGER MANUAL AIR VENT
 - [46] SECONDARY HEAT EXCHANGER
 - [47] PRESSURE RELIEF VALVE

4 Pre-Installation

4.1 Cleaning primary systems



Before installation

- ▶ All the following Pre-Installation sections must be read and requirements met before starting boiler or flue installations.



CAUTION: Mains power

- ▶ Isolate the mains supplies before starting any work and observe all relevant safety precautions.



Protect the boiler

- ▶ Debris from the system can damage the boiler and reduce efficiency. Failure to comply with the guidelines for the use of water treatment with the appliance will invalidate the appliance warranty.
- ▶ It is recommended that a primary water cleanser is fitted to the system. Worcester offers a system filter that helps remove both magnetite and non-magnetic debris.

BEFORE CLEANING THE SYSTEM:

- ▶ **Ensure that the system and pipe work is in good working order.**
- ▶ **Where possible keep the existing boiler/circulating pump in place when flushing the system.**

FOLLOW THE GUIDANCE OF BS7593

Treatment of water in domestic hot water central heating and also the flushing guidelines below.

FLUSHING THE SYSTEM

- ▶ Fill the system with cold water and check for leaks.
- ▶ Open all drain cocks and drain the system.
- ▶ Close drain cocks and add a suitable flushing agent at the correct strength for the system conditions in accordance with the manufacturer's instructions.
- ▶ Circulate the flushing agent before the boiler is fired up.
- ▶ Run the boiler/system at normal operating temperature as directed by the manufacturer of the flushing agent.
- ▶ Drain and thoroughly flush the system to remove the flushing agent and debris.
- ▶ It may be necessary to use a power flushing machine to aid the cleansing procedure in some circumstances.
- ▶ Close the drain cocks and refill with fresh water and a suitable inhibitor.
- ▶ Vent any air from the boiler and system.

INHIBITOR

Add a suitable inhibitor or combined inhibitor/anti-freeze, if the system is exposed to freezing conditions, to the heating system in accordance with the DWTA code of practice and inhibitor manufacturer's guidelines.



WARNING: Sealing agents

- ▶ In cases where all attempts to find a system micro leak have failed, Worcester, Bosch Group supports the use of Fernox F4 leak sealer.

Water treatment

Suitable water treatment products can be obtain from the following manufacturers:

FERNOX	0870 601 5000 www.fernox.com
SENTINEL	0800 389 4670 www.sentinel-solutions.net

ARTIFICIALLY SOFTENED WATER

It is possible to have an ion exchange water softener fitted to the cold water system of the property. However, the boiler requires an untreated cold water connection taken from the mains supply, before the water softener, to the primary water filling point of the heating system.

Alternatively there are water softening/treatment devices that do not adjust or alter the pH levels of the water. With these devices it may not be necessary to provide an untreated water by-pass to the primary water filling point of the heat system.



Artificially softened water must not be used to fill the central heating system.

4.2 Mains supply

4.2.1 Electrical supply

- Supply: 230V - 50 Hz
- Cable: PVC insulated 0.75mm² (24 x 0.2mm) temperature rated to 90°C.
- Circuit breaker incorporating earth leakage protection.
- External 5A fuse to BS1362.
- The appliance must be earthed.
- This appliance must not be connected to a three phase supply.
- Wiring must comply with the latest IET wiring regulations.
- It must be possible to isolate the appliance from the electrical supply with at least a 3mm contact separation in both poles supplying the appliance.
- Wiring between the appliance and the electrical supply must comply with IET wiring regulations and any local regulations that may apply for fixed wiring to a stationary appliance.
- Any system connected to the boiler must not have a separate electrical supply.

4.2.2 Water supply

The following are general requirements and if necessary the advice of the local water company should be sought before fitting the appliance.

- The appliance cold water supply should be the first connection off the water main where possible.
- The appliance will accept pre-heated hot water to a maximum of 60°C

Mains water pressure



NOTICE: Boiler damage

- ▶ Non-return, back flow prevention devices (including those associated with water meters) fitted to the mains water supply can cause a pressure build up which could damage the boiler and other household appliances.

Minimum dynamic mains water pressure for maximum performance

12/18kW	18/25kW	25/32kW
1.5bar	1.2bar	1.6bar

- Maximum mains fed water pressure 10 bar. If necessary, fit a pressure reducing valve.
- Where the water main supply has a non-return, back flow prevention valve fitted, a mini expansion vessel (A) must be connected to the mains water inlet pipe (B) between the non-return valve (C) and the boiler (D) as shown in figure 3.

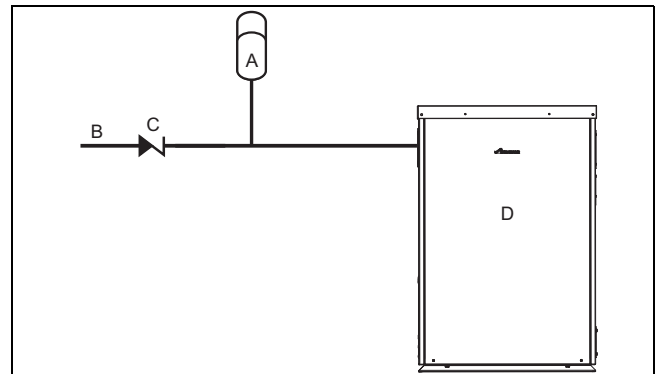

Fig. 3 Mains expansion vessel

- [A] Mini expansion vessel
- [B] Mains water inlet
- [C] Non return valve
- [D] Boiler

Use in hard water areas

Normally there is no need for water treatment to prevent scale formation as the maximum temperature of the heat exchanger is limited by the electronic control circuit.

In areas where the temporary water hardness exceeds 200ppm, consideration may need to be given to the fitting of a scale prevention device. In such circumstances, the advice of the local water authority should be sought.

4.2.3 Oil supply



NOTICE: Contaminated oil supplies can damage the appliance.

Failure to ensure that the oil supply is clear of contaminants may invalidate the appliance warranty.

- ▶ Ensure the oil supply is free of contaminates and measures are taken to prevent contamination of the appliance.

- **This appliance is suitable for Kerosene (Class C2) only, no other fuel must be used.**
- Plastic or steel tanks should be installed to BS 5410. A steel tank should conform to BS 799: part 5 and have a slope of 1:24 away from the outlet with a sludge cock at the lower end.
- **Do not use galvanised steel tanks or pipework for the oil system.**
- **Do not use soldered joints on the oil supply pipework.**

Single pipe gravity feed system

The oil storage tank [1] must be positioned so that the oil level does not exceed 4 metres above the level of the burner oil pump [9] and in addition the oil level must be at least 300mm above the oil pump [9]. Where the maximum oil level in the oil storage tank exceeds 4 metres, a head breaking device must be installed between the tank [1] and the burner oil pump [9].

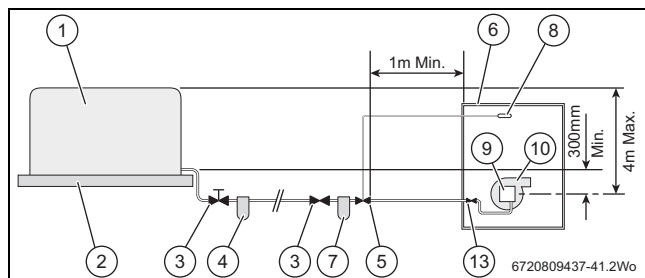

Fig. 4 Single pipe feed

- [1] Oil storage tank
- [2] Full base (plastic tank)
- [3] Isolating valve
- [4] Oil strainer and water separator
- [5] Fire valve to BS 5410
- [6] External boiler casing
- [7] Oil filter (70µm max filtration size)
- [8] Fire valve sensor
- [9] Oil pump
- [10] Oil burner
- [11] Non-return valve
- [12] De-aerator

i All dimensions are in metres unless otherwise stated. The maximum pipe run figures are based on using copper pipe with an inside diameter of 2mm less than the outside diameter.

Maximum pipe run for single pipe gravity fed system

Head [M]	10mmØ	12mmØ	Head [M]	10mmØ	12mmØ
0.5	12	30	2.5	62	100
1.0	25	69	3.0	74	100
1.5	37	91	3.5	87	100
2.0	49	100	4.0	99	100

Double pipe sub-gravity fed system

Maximum suction height 3.5 metres. Non-return valves must be fitted to the inlet and return oil line between the oil pump [9] and oil storage tank [1].

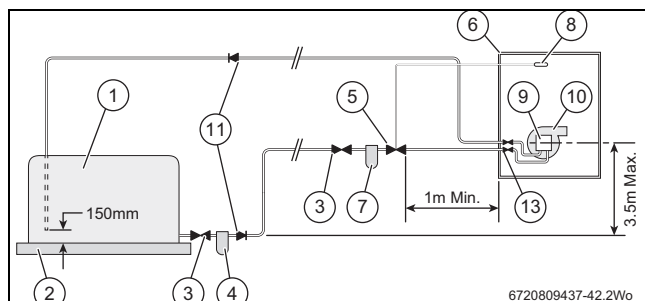

Fig. 5 Double pipe feed

Maximum pipe run for double pipe sub-gravity fed system

Head [M]	10mmØ	12mmØ	Head [M]	10mmØ	12mmØ
0	50	100	2.0	26	66
0.5	44	100	2.5	20	50
1.0	38	95	3.0	14	37
1.5	32	80	3.5	8	22

Single pipe suction lift with de-aerator

Maximum suction height 3.5 metres. The oil tank [1] must be positioned below the oil pump [9]. Create an inlet and return loop between the de-aerator [12] and oil pump [9].

A non-return valve must be incorporated within the de-aerator or fitted to the oil line between the oil storage tank [1] and the de-aerator [12]. A top feed oil tank fitted with a de-aerator using an internal non-return valve should have any non-return valves fitted in the base of the tank to the suction line removed to assist purging air from the oil line.

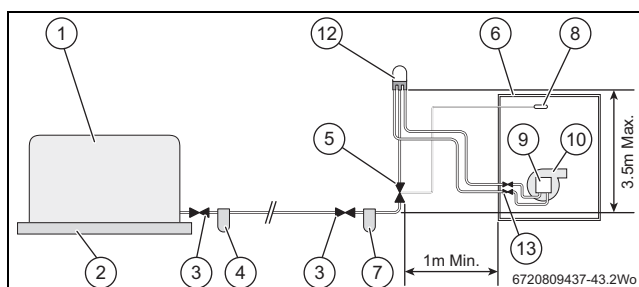

Fig. 6 De-aerator feed

Maximum pipe run for single pipe suction lift with de-aerator

Head [M]	FUEL FLOW RATE			
	2.5kg/h 8mmØ	5kg/h 8mmØ	10kg/h 8mmØ	10kg/h 10mmØ
0	100	55	26	100
0.5	95	45	23	100
1.0	80	40	20	90
1.5	70	35	17	75
2.0	60	30	14	65
2.5	45	25	11	50
3.0	35	15	8	35
3.5	25	10	5	20

i The table and illustration above is a guide only and does not in any way override the de-aerator manufacturer's instructions

4.2.4 Pipework

CAUTION: Fire protection device
 Under no circumstances should a combination isolating/fire valve be used as the sole fire protection device

- ▶ Use flexible hoses to connect to the oil pump [9].
- ▶ Lay the oil supply pipe as straight and level as possible to avoid air pockets and unnecessary friction losses. Route away from the boiler access door or other hot surfaces.
- ▶ Install a manual isolating valve [3] to the oil supply pipe, as close to the oil storage tank [1] as possible.
- ▶ Fit an oil strainer and water separator [4] to the oil supply pipe, near the oil storage tank. Fit an additional oil filter ([7], 70 µm max filtration size) close to the boiler, but not inside the boiler casing.

- ▶ Fit a fire valve in accordance with BS 5410. The fire valve [5] should be fitted externally to the building with the fire valve sensor [8] located within the appliance case. A fire valve with a shut off temperature of 85°C or higher must be fitted to avoid the possibility of a nuisance shut off. The fire valve must be a minimum of 1 metre from the appliance. A capillary type valve provides a neat and simple installation, or a fusible link or electrical system may be used.

4.2.5 Boiler isolation valve

- ▶ Use copper pipe of the correct diameter according to the information shown in oil supply sections, & .
 - If using soft copper pipe (R220) with a compression fitting, an insert must be used to prevent the pipe from collapsing or distorting when the fitting is tightened.
- ▶ Slide nut [1] and olive [5] onto the oil supply pipe [4].
- ▶ Slide insert [3] into the pipe.
- ▶ Offer the pipe to the fitting [2] and tighten the nut [1].

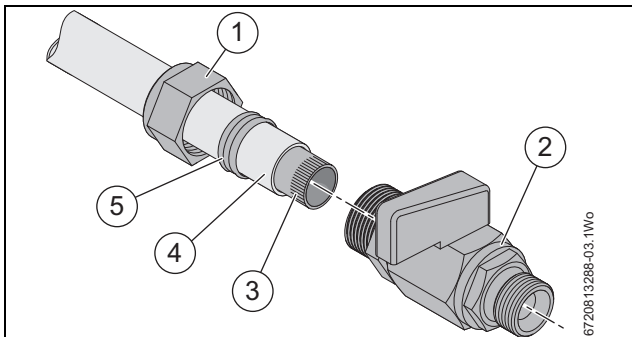

Fig. 7 Isolation valve bracket removed for clarity

- ▶ Use flexible hoses to connect from the boiler isolation valve/s and the oil pump.

4.3 Water systems and pipework

i The boiler should not be allowed to operate with a return temperature of less than 30°C when the system is up to operating temperature.

Primary system plastic pipework

- Any plastic pipework used for the CH system must have a polymeric barrier, complying with BS 7921 and installed to BS 5955 with 1000mm (minimum) length of copper or steel pipe connected to the boiler.
- Plastic pipework used for underfloor heating must be correctly controlled with a thermostatic blending valve limiting the temperature of the circuits to approximately 50°C with 1000 mm (minimum) length of copper or steel pipe connected to the boiler, and a 20 K differential must be maintained at the appliance.

Primary system/connections/valves

- Do not use galvanised pipes or radiators.
- All system connections, taps and mixing valves must be capable of sustaining a pressure of 3 bar.
- Radiator valves should conform to BS 2767:10.
- All other valves should conform to BS 1010.
- An automatic bypass valve must be connected between the heating flow and return where TRVs are used on all radiators, fitted to give at least a 3 metre circuit when activated.
- Drain cocks are required at all the lowest points on the system.
- Air vents are required at all high points on the system.

Sealed primary system

- Where the system volume is more than 180 litres at 0.5 bar or exceeds 2.65 bar at maximum heating temperature an extra expansion vessel (B) must be fitted as close as possible to the appliance in the central heating return.

- Pressurise the extra expansion vessel (B) to the same figure as the expansion vessel (A) built into the appliance.

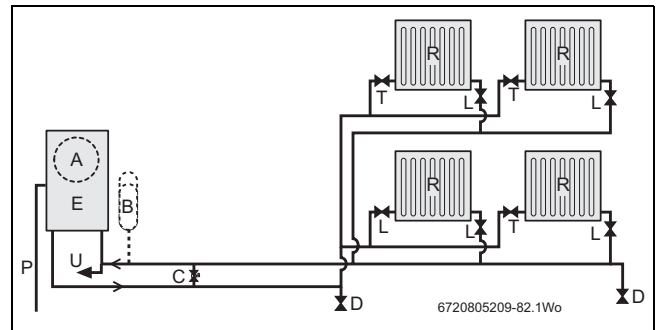

Fig. 8 Regular boiler, open vent system layout

- [A] Expansion vessel*
- [B] Extra expansion vessel
- [C] Automatic bypass valve
- [D] Drain cock
- [E] Appliance
- [L] Lockshield valve
- [R] Radiators
- [T] Thermostatic radiator valve TRV
- [U] To filling system

Filling primary sealed systems

i **Filling the system**
▶ The system must not be filled with artificially softened water.

- Where the system volume is more than 180 litres at 0.5 bar or exceeds 2.65 bar at maximum heating temperature an extra expansion vessel [B] must be fitted as close as possible to the appliance in the central heating return.
- Pressurise the extra expansion vessel [B] to the same figure as the expansion vessel built into the appliance (system boilers).
- Filling the system must comply with the method shown in the figure below.
- The filling point must be at low level and must never be a permanent connection to the mains water supply.
- Filling loops must be WRAS approved.

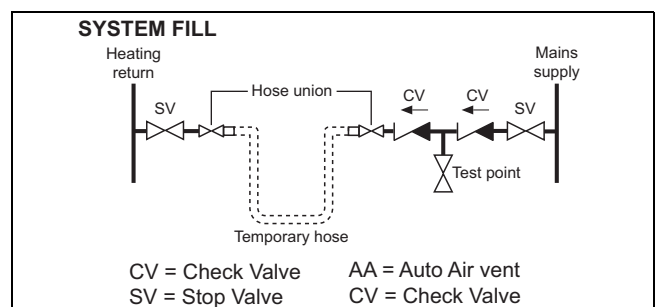

Fig. 9

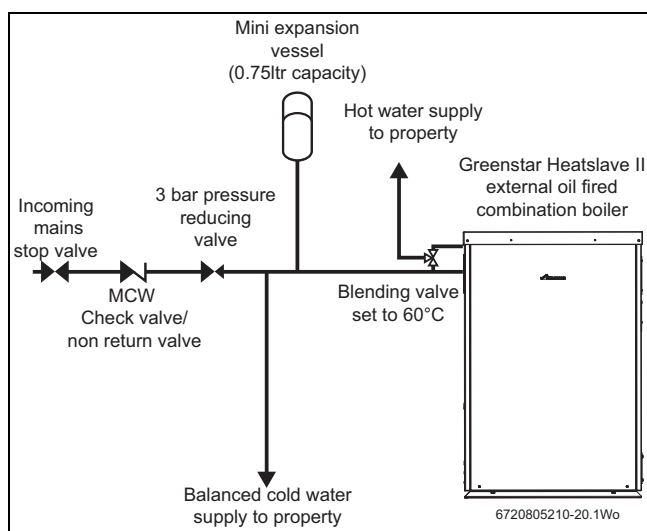

Fig. 10

Showers/Bidets:

- If a shower head can be immersed in water or comes closer than 25mm from the top edge of a bath or shower tray spill over level then an anti-siphon device must be fitted to the shower hose. Only thermostatically controlled showers are suitable for use with this appliance.
- Bidets with direct hot & cold mains water can be used (with the approval of the local water authority) and must be the over rim flushing type with shrouded outlets to prevent the fitting of hand held sprays.

Domestic hot water:

Plastic pipework

- Any plastic pipework used for the DHW system must have a polymeric barrier, complying with BS 7921 and installed to BS 5955 with 1000mm (minimum) length of copper or stainless steel pipe connected to the boiler.
- Before installing plastic pipework, the pipe manufacturer's literature should be consulted.
- To prevent the temperature & pressure exceeding the limits advised by the pipe manufacturer, a pressure reducing valve must be used to prevent the incoming water pressure exceeding 3 bar (maximum). Also a mini expansion vessel must be fitted to absorb the expanding water and a blending valve set to 60°C must be fitted before the DHW plastic pipework.
- When selecting plastic pipework for use with domestic water supply, it should be ensured that it is compliant with all current local & national legislation & regulations, including building regulations part G, BS 7291 - 1,2 & 3: 2006, BS 8000 - 15-15: 1990 and information.

General:

- Taps and mixing valves must be capable of sustaining a pressure up to 10 bar in accordance with the Water Regulations as they will be operating at mains water pressure.
- Hot water temperature and flow rate are affected by the size and insulation of pipework making up the distribution system and are controlled by the hot water tap and the water main inlet pressure. A mixing valve can be fitted if a more permanent setting is required.
- If using more than one outlet at once causes water flow starvation, fit flow balancing valves or Ball-O-Fix valves to the appropriate outlets.

4.4 Condensate pipework



- ▶ The condensate pipe must be nominally 21.5mm Ø Polypropylene pipe.
- ▶ The condensate pipe work must fall at least 52mm per metre towards the outlet and should take the shortest practicable route.
- ▶ Ensure there are no blockages in the pipe run.

Externally run condensate drainage pipe should terminate at a suitable foul water discharge point, or purpose-designed soak away. If this method is chosen then the following measures should be adopted:

- ▶ The external run be kept as short as possible and not exceed three metres.
- ▶ The pipe diameter should be increased to 32mm and should be insulated using suitable waterproof and weather resistant insulation.
- ▶ The external pipe should take the shortest and least exposed route to the discharge point, and should "fall" as steeply as possible away from the boiler, with no horizontal runs in which condensate might stand.
- ▶ The use of fittings, elbows etc. should be kept to a minimum and any internal "burrs" on cut pipe work should be removed so that the internal pipe section is as smooth as possible.

4.4.1 Condensate disposal connections



Condensate drainage pipe can be run above or below ground.

Key to condensate illustrations

1	Condensate discharge from boiler
2	Universal connector
3	Soil and vent stack
4	Minimum 450mm and up to three storeys
5	Pipe work transition
6	Insulate and increase pipe size
7	External rain water pipe into foul water
8	External air brake
9	43mm pipe (min 100mm upstand)
10	PVCu strap on fitting
11	43mm 90° male/female bend
*	Condensate trap of 75mm already incorporated into the boiler

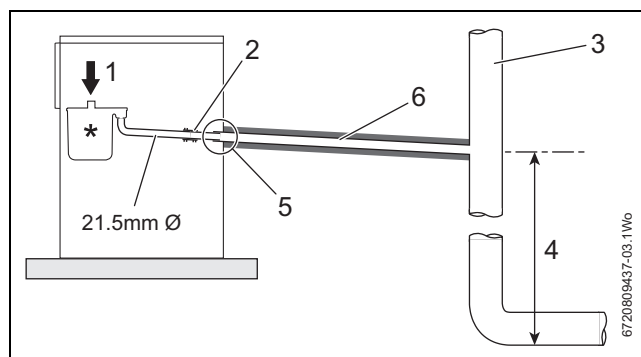

Fig. 11 Disposal to a soil vent stack

Fitting an external air break

- Refer to figure 12 when a rain water down pipe is used to dispose of condensate.
- An air break must be installed in the 43mm pipe work, between the boiler condensate outlet and the drainpipe, outside the property, to avoid flooding during adverse weather conditions.

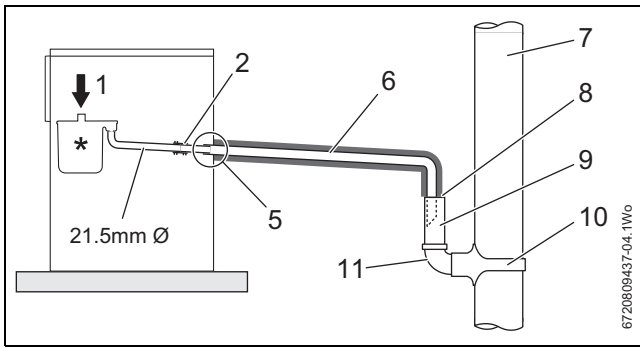

Fig. 12 Disposal into a rainwater down pipe

Where the pipe terminates over an open drain or gully, the pipe should terminate below the grating level, but above water level, in order to minimise “wind chill” at the open end.

The use of a drain cover (such as those used to prevent blockage by leaves) may offer further protection from wind chill.

Pipe drainage will be improved if the end is cut at 45° as opposed to a straight cut.

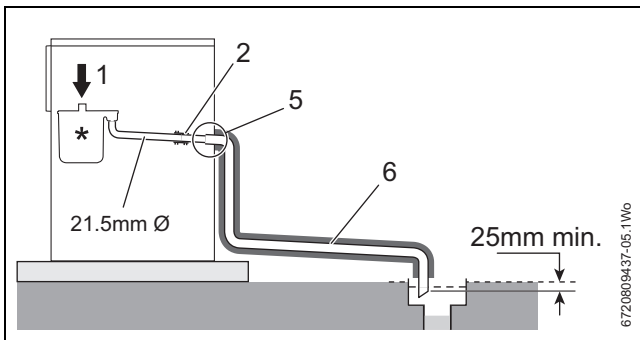

Fig. 13 External drain

4.4.2 Soak away



Condensate waste

- ▶ Care should be taken when siting a soak-away to avoid obstructing existing services.

- The condensate drainage pipe may be run above or below the ground to the soak away. The examples shown on this page run above ground.
- The soak away must use a 100mm Ø plastic tube with two rows of three 12mm holes on 25mm centres and 50mm from the bottom of the tube. The holes must face away from the house.
- The tube must be surrounded by at least 100mm of limestone chippings to a depth of 400mm.



Minimum hole size for the condensate soak away must be 400mm deep by 300mmØ .

In situations where there are likely to be extremes of temperature or exposure, the use of a proprietary trace-heating system for external pipe work, incorporating an external frost thermostat, should be considered. If such a system is used, the requirement to use 32mm pipe does not apply. However, all other guidance above and the instructions for the trace heating system, should be closely followed.

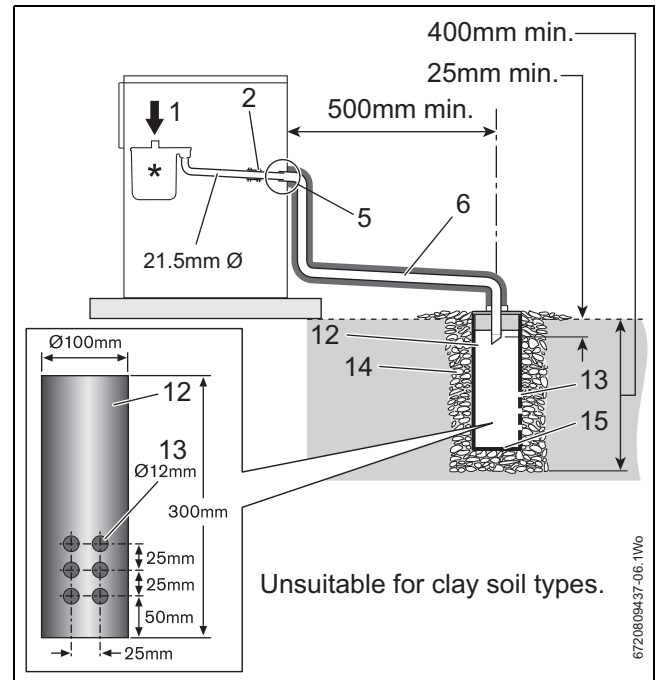

Fig. 14 Disposal to a soakaway

Key to condensate soakaway

1	Condensate discharge from boiler
2	Universal connector
3	Soil and vent stack
4	Minimum 450mm and up to three storeys
5	Pipe work transition
6	Insulate and increase pipe size
12	100mm Ø minimum plastic pipe
13	Drainage holes
14	Limestone chippings (25kg min.)
15	Bottom of sealed tube
*	Condensate trap of 75mm already incorporated into the boiler

4.5 Pressure relief pipework

- The pressure relief discharge pipe [2] should be at least 15mm diameter copper pipe and run downwards away from the boiler and discharge away from any electrical or other hazard, preferably to an external drain or soakaway.
- Pipe [2] should be finished with a partial bend, near the outlet to prevent discharge onto entrances or other public access where it could cause a hazard.

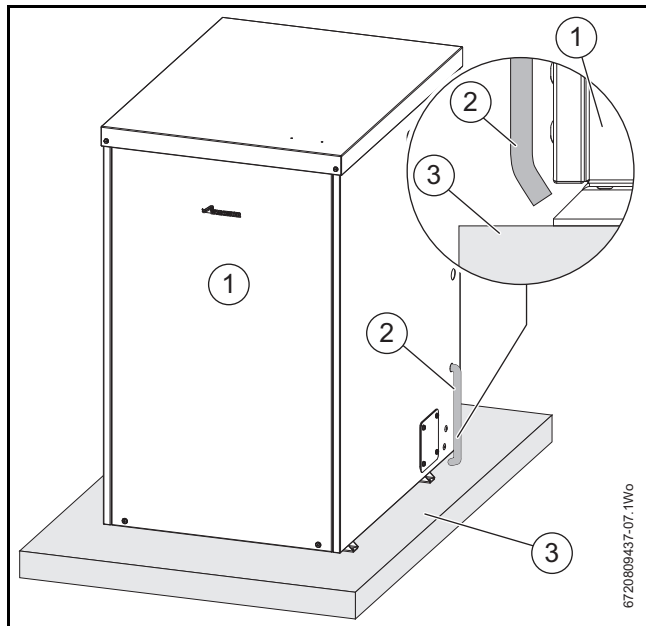

Fig. 15 Pressure relief pipe work

- [1] External casing
- [2] PRV discharge pipe
- [3] Hardstanding

4.6 Boiler locations and clearances

WARNING: This appliance should not be installed where there is a potential for excessive ground water coverage. This boiler is only suitable for installing externally at a suitable location onto a fixed permanent rigid surface capable of supporting the boiler weight. There must be a sufficient hard standing around the appliance to allow for servicing. The boiler must be installed on a flat level surface to ensure that condensate does not enter the primary heat exchanger. Tarmac and wood hard-standings are not recommended.

Clearances:

- ▶ Minimum service and flue clearances.
 - Above - 600mm
 - Front - 600mm
 - RH/LH clearance on the other side of the flue outlet - 10mm
 - RH clearance flue outlet on rear - 45mm
 - LH clearance flue outlet on rear - 85mm
 - Rear clearance flue outlet on side - 50mm
 - Rear clearance flue outlet on rear 2500mm
- It is strongly recommended that the flue terminal faces away from walls to reduce the possibility of wetting occurring.

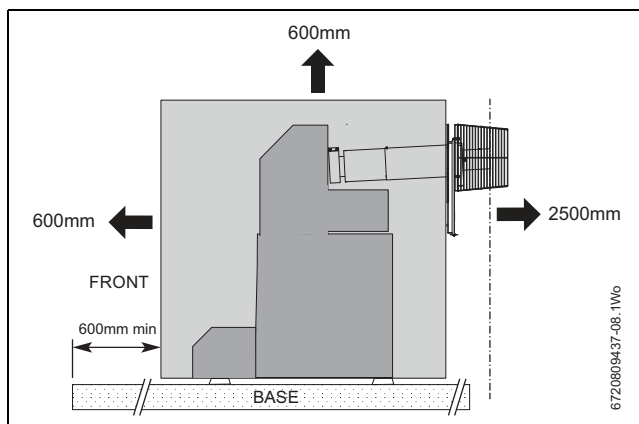

Fig. 16 Above clearance

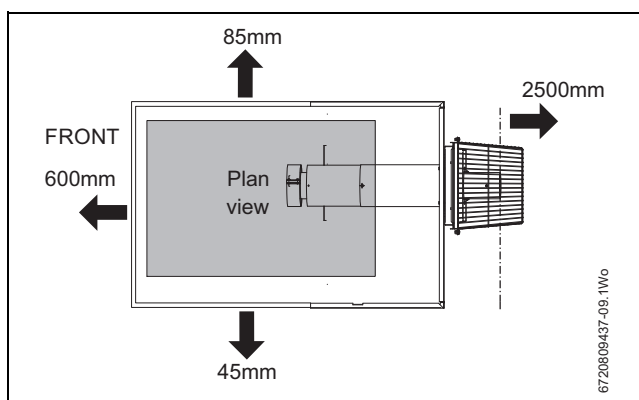

Fig. 17 Rear exit flue clearances

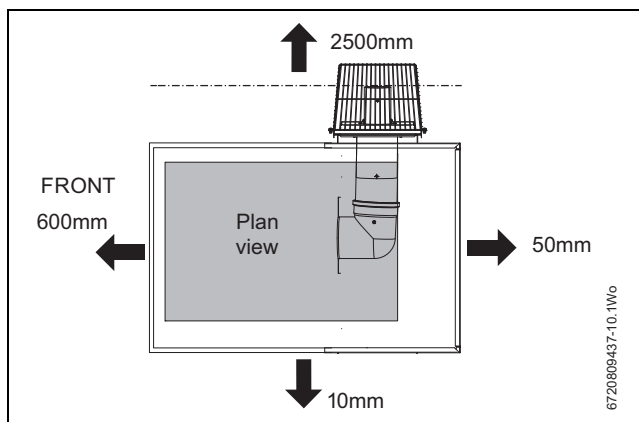

Fig. 18 Left exit flue clearances

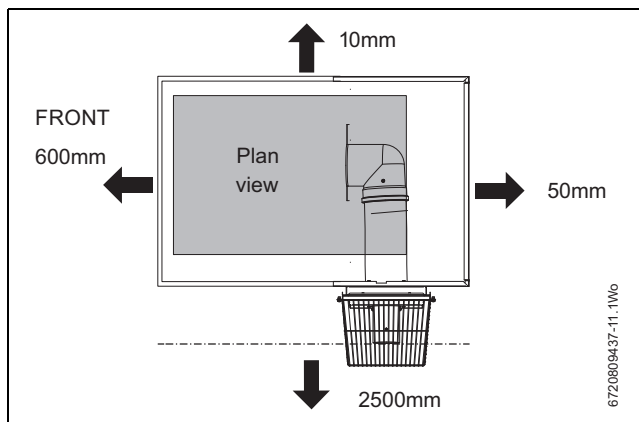

Fig. 19 Right exit flue clearances

4.7 Flue terminal positions

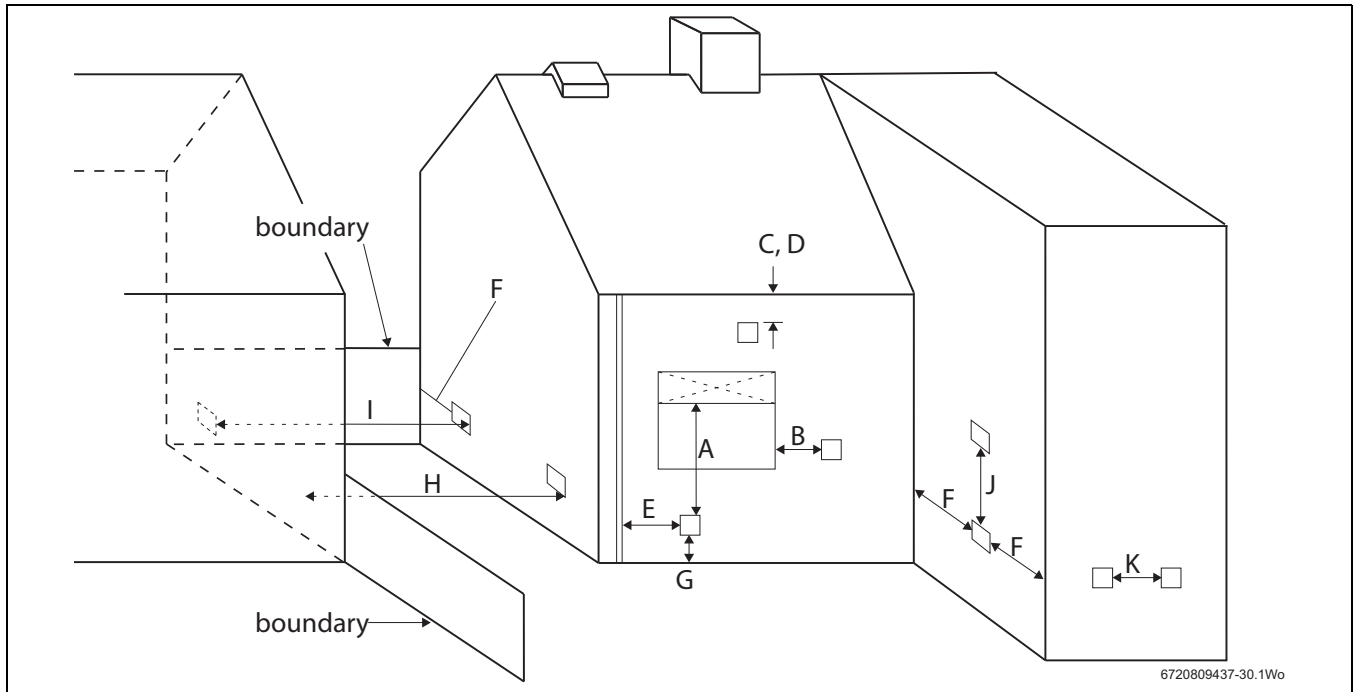

Fig. 20 External boiler flue terminal positions

	Terminal position	Balanced horizontal flue
A ¹	Directly below an opening, air brick, opening window etc.	600mm
B ¹	Horizontally to an opening, air brick, opening window, etc.	600mm
C	Below a plastic/painted gutter, drainage pipe or eaves if combustible material is protected	75mm
D ²	Below a plastic/painted gutter, drainage pipe or eaves without protection to combustible material	600mm
E	From vertical sanitary pipework	300mm
F	From an external or internal corner or from a surface or boundary alongside a terminal	300mm
G	Above ground or balcony level	300mm*
H	From a surface or boundary facing a terminal	600mm**
J	From a terminal facing a terminal	1200mm**
K	Vertically from terminal on the same wall	1500mm

Table 4

- An opening means an openable element, such as an openable window, or a permanent opening such as a permanently open air vent.
Notwithstanding the dimensions above, a terminal should be at least 300mm from combustible material, e.g. a window frame. Terminals should be positioned so as to avoid products of combustion accumulating in stagnant pockets around the building or entering into buildings.
 - A way of providing protection of combustible material would be to fit a heat shield at least 750mm wide.
 - Terminating positions should be at least 1.8m from an oil storage tank unless a wall with at least 30 minutes fire resistance and extending 300mm higher and wider than the tank is provided between the tank and the terminating position.
- The following additional guidelines (from part L Exceptions Guidance Document) are recommended when determining the flue outlet position:
 - Avoid discharging flue gases into car ports or narrow passageways.
 - *Minimum distance of the flue terminal from above ground is 2100mm where directed to a public footpath, private access route or a frequently used area and 2500mm from a car parking area.
 - **Recommended minimum distance of the flue terminal to a facing wall, fence, building or property boundary is 2500mm.
 - Terminals should be positioned so as to avoid products of combustion accumulating in stagnant pockets around the building or entering into buildings.
 - The flue must be fitted and terminated in accordance with the recommendations of BS5410.
 - The flue must not cause an obstruction.
 - Discharge from the flue outlet must not be a nuisance.
 - Flue gases have a tendency to plume and in certain weather conditions a white plume of condensation will be discharged from the flue outlet which could be regarded as a nuisance, for example, near security lighting.
 - There should be no restriction preventing the clearance of combustion products from the terminal.
 - The air inlet/outlet duct and the terminal of the boiler must not be closer than 25mm to any combustible material. Detailed recommendations on protection of combustible materials are given in BS 5410:1
 - A protective stainless steel terminal guard, must be fitted if the terminal is 2m or less above a surface where people have access.
 - The guard must be spaced equally (minimum 50mm) around the flue and fixed with plated screws.
 - See 'Contact Information' on the back cover for flue guard information.

4.8 Flue options

4.8.1 Cabinet mounted balanced horizontal flue options



It is strongly recommended that the flue terminal faces away from walls to minimise the occurrence of wetting.

- The horizontal flue is fitted to the rear or either side of the cabinet.

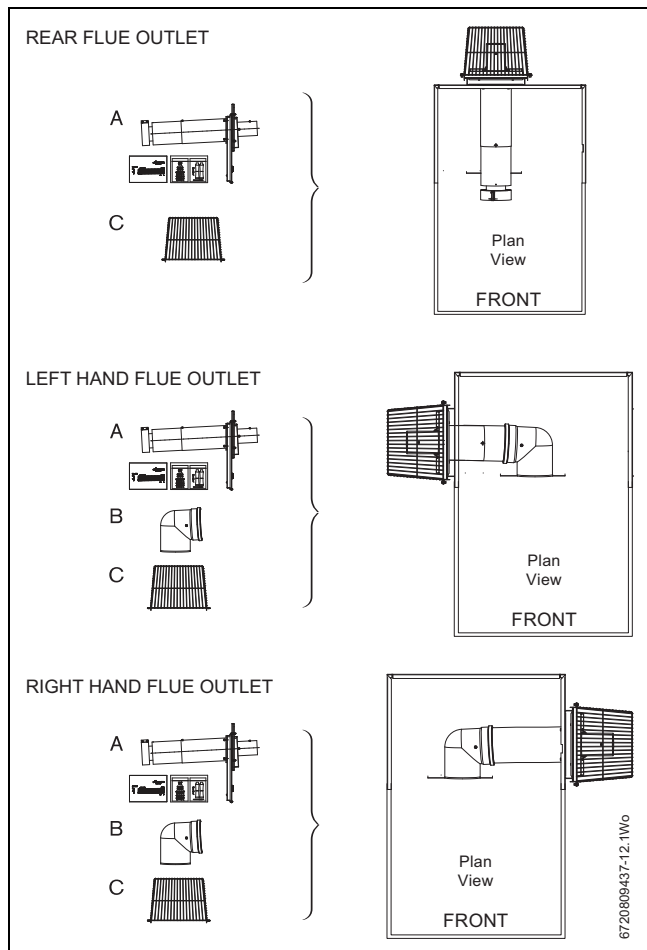

Fig. 21 Flue options

4.8.2 Plume management

1. Measure the plume management flue (M) from the centre of terminal, along the required route to the centre of the plume outlet.

Heatslave II	Flue length (L)	Plume length (M)
12/18 & 18/25	160 - 2000mm	500 - 5000mm
Bends	maximum of 2	maximum of 2
25/32	160 - 2000mm	500 - 4000mm
Bends	maximum of 2	maximum of 2

Effective lengths of elbows		
Bend	Flue	Plume
90°	1000mm	1000mm
45°	500mm	500mm

Table 5 Effective lengths of bends

Fitting the terminal plume management kit

1. Remove and retain the screws that secure the terminal end into the flue.
2. Discard the terminal end.
3. Fit the terminal elbow into the flue but do not secure with the screws until the plume management system has been assembled.

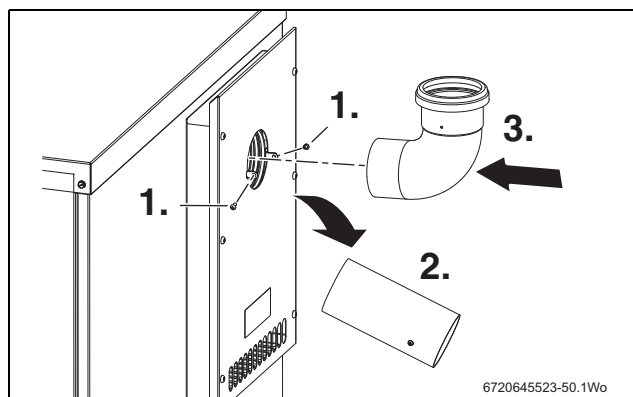

Fig. 22 Fitting the terminal bend

1. Connect the sections of the plume management for desired length.
 - Screw the clamp into the wall.
 - Push the extension/s tube fully into the 90° bend, then withdraw the tube by approximately 10mm to allow for expansion.
2. Once the plume management system is in place and secured to the wall, secure the terminal bend with the screws remove earlier.
 - ▶ The terminal end can be positioned up to 45° either side of the central position, for plume re-direction.
 - ▶ Adjust the plume management terminal end into the desired position and secure with the screws provided.

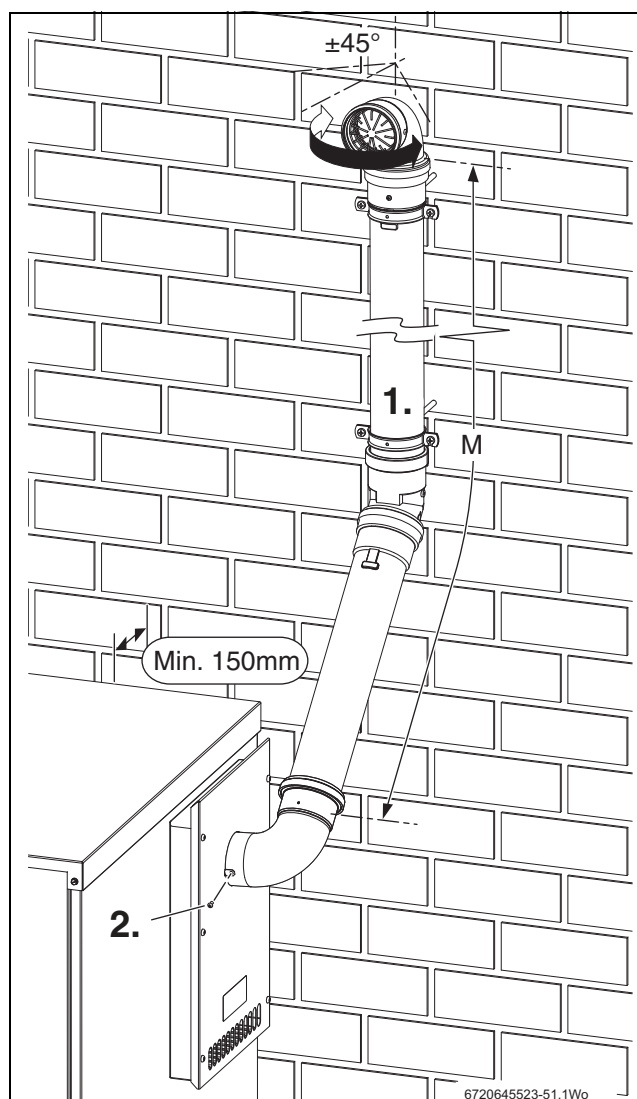

Fig. 23 Plume management detail

5 Installation

5.1 Unpacking the boiler



All the previous Pre-Installation sections must be read and requirements met before starting boiler or flue installation



LIFTING AND CARRYING PRECAUTIONS:

- ▶ Lift only a manageable weight, or ask for help.
- ▶ When lifting or putting things down, bend the knees, and keep the back straight and feet apart.
- ▶ Do not lift and twist at the same time.
- ▶ Lift and carry objects close to the body.
- ▶ Wear protective clothing and gloves to protect from any sharp edges.

Unpacking

It is advised that two or more persons are involved in the transfer of the packaged boiler from the van to the point of delivery.

- ▶ Once the packaged boiler has been delivered, the outer carton is removed first. Care should be taken when releasing the straps. If a sharp implement is used make sure the outer carton is not pierced and that the implement is used in such a way so that it may not cause personal injury. All sharp objects must be covered or the blade retracted after use and put away in a safe place.
- ▶ Lift carton up and away from the boiler.
- ▶ Remove the plastic bag from the boiler and place safely aside.

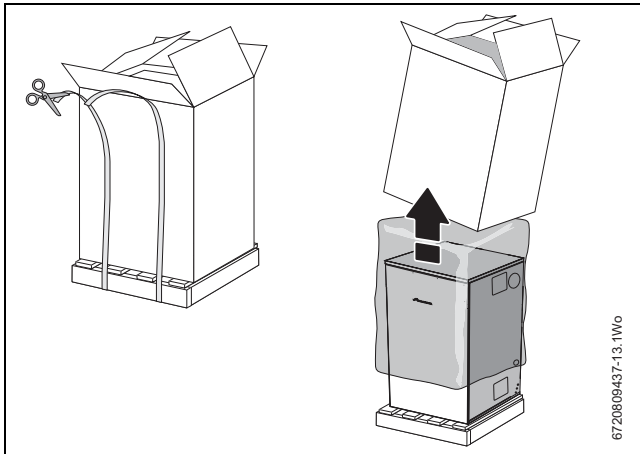

Fig. 24

5.2 Pipework and flue positions



CAUTION: Ensure there are no pipes, electric cables, damp proof courses or other hazards before drilling.

Safety

All relevant safety precautions must be undertaken. Protective clothing, footwear, gloves and safety goggles must be worn as appropriate.

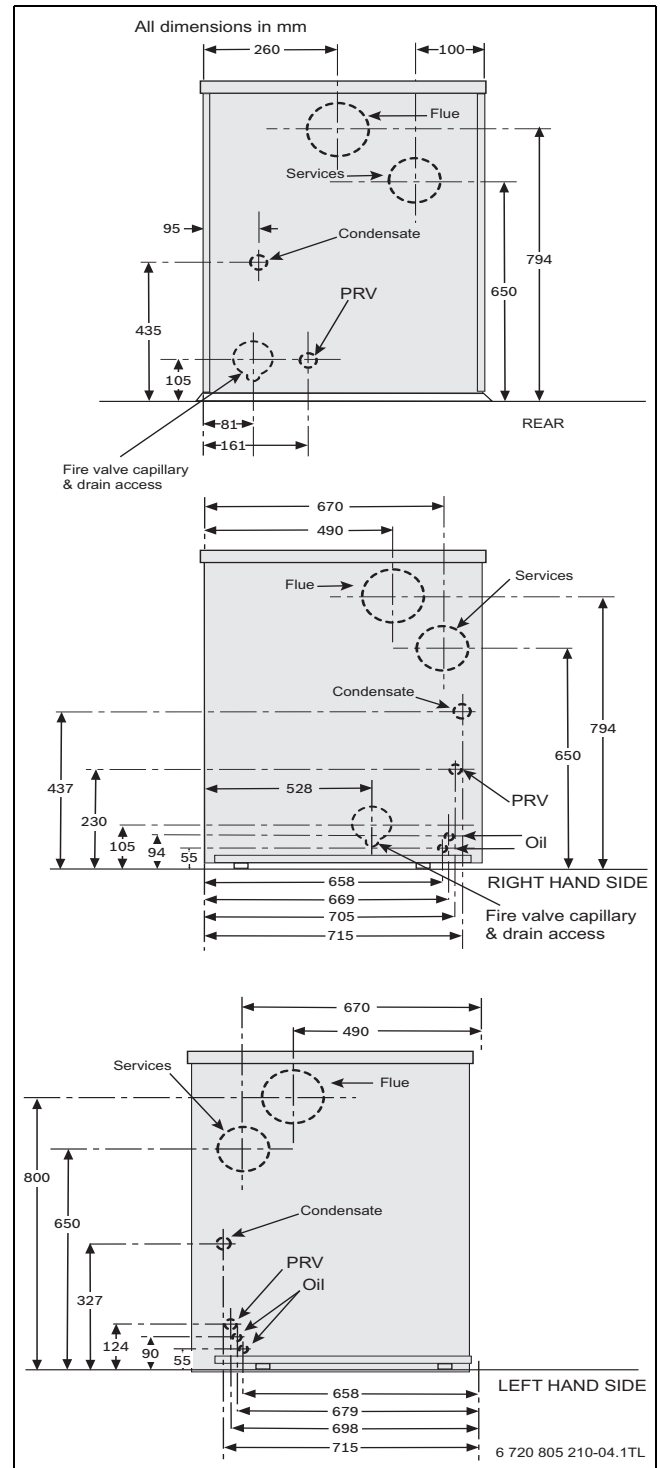

Fig. 25

Pipework connections:

- ▶ Flow;
 - 22mm Ø copper 12/18, 18/25 models
 - 28mm Ø copper on 25/32 model
- ▶ Return;
 - 22mm Ø copper 12/18, 18/25 models
 - 28mm Ø copper on 25/32 model
- ▶ DCW In 15mm Ø copper.
- ▶ DHW Out 22mm Ø copper.
- ▶ PRV 15mm Ø copper.
- ▶ Services duct 100mm Ø.
- ▶ Condensate outlet 21.5mm Ø.
- ▶ Primary drain - hose connection.



For servicing purposes, keep the condensate and pressure relief (PRV) discharge pipes away from components and pipe work connections.

5.3 Boiler installation



WARNING: This appliance is serviced & repaired externally.
 ▶ 230 V external equipment should not be installed, serviced or repaired in adverse weather conditions.



This appliance is installed and serviced externally to the property, but the engineer must have access to the inside of the property when installing or servicing the appliance.

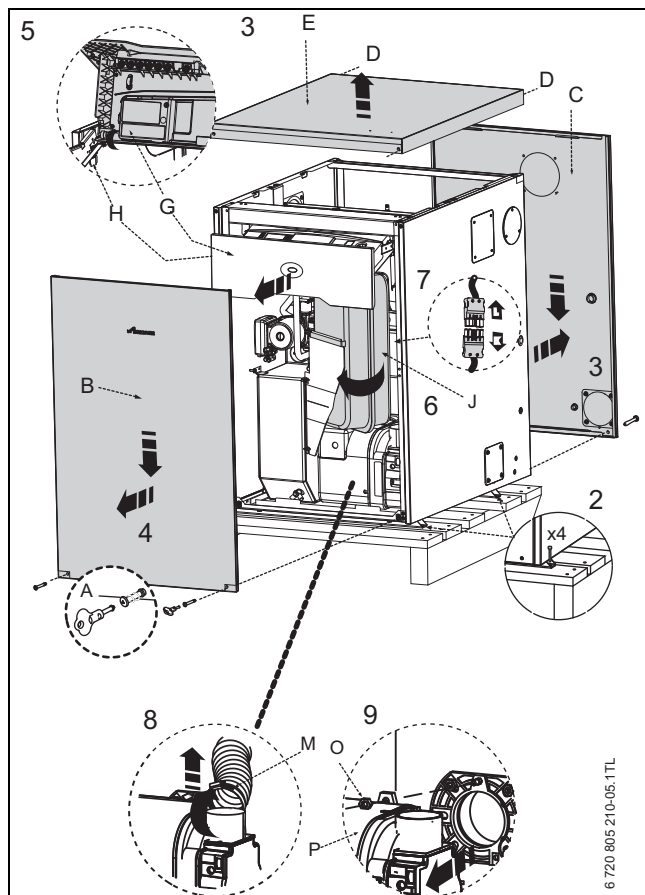

Fig. 26



The cabinet is not load bearing it only provides weather protection for the boiler inside.

1. Mark position of the 100mm services duct on the exterior wall and make a hole through.
2. Remove the screws securing the base panel to the transit pallet and lift the boiler off the pallet and into its installation position taking care not to scrape the base panel across the hard standing. **Do not attempt to lift and position the boiler on your own. Do not use the copper pipes to move the boiler.**
 - Fasten the base to the hard standing using the holes provided. Care should be taken to ensure that the base is level.
3. Remove the screws [D] from each corner of the top panel [E] and lift up to remove, store safely away from the installation point.

4. Remove the key [A] for the door fasteners from the literature pack. Undo the screws at the bottom of the front panel [B] using the key provided and remove the screws from the rear panel [C] - (optional) pulling both panels down and out to remove. Store safely away from the installation point.
5. Pull control box drawer [G] forward.
 - Depress the two levers [H], one on either side beneath the slide rail, to release the control box and pull fully forward.
 - Swivel the complete control box assembly upwards.
6. Swivel the expansion vessel [J] on its support bracket out of the boiler, taking care not to snag any electrical cables or kink the flexible hose.
7. Unplug the burner lead [K] from the control box lead [L].
8. Loosen the flexible air duct clamp [M] and remove the air duct from the burner.
9. Undo and remove the retainer [O] on top of the burner. The burner [P] can now be removed from the heat exchanger. Store the burner and retainer nut safely away from the boiler.
 - Measure the 100mm Ø services duct to give at least 10mm inside the casing and to finish flush with the interior wall surface, cut to size and fit the duct. Fit the 100mm sealing ring where the duct enters the casing and seal the joint to the exterior wall and inside the cabinet with a suitable sealant.

5.4 Flue installation

Installation notes

- ▶ Ensure all the seals are in good condition and seated properly.
- ▶ To ease assembly of flue components, grease seals lightly with the solvent free grease supplied.
- ▶ A terminal guard must be fitted if the terminal is 2metres or less above a surface that can be accessed by people.

All flue options

- ▶ Lightly grease the flue cowl seal with the solvent free grease supplied.
- ▶ Carefully remove the blanking plate from the appropriate flue aperture (if necessary) and refit the blanking plate in the unused aperture.
- ▶ Carefully remove the insulation from the flue aperture in the cabinet that the flue is to pass through, and fit to the unused aperture.
- ▶ Refer to the flue manual supplied with the flue kit for flue installation.

5.5 Combustion chamber

- ▶ Unscrew screws [G] and remove flue manifold access cover [H].
- ▶ Check that all the baffles [J] and baffle retainer [K] are correctly fitted to the secondary heat exchanger.
- ▶ Remove the retaining nuts and washers [B].
- ▶ Remove combustion chamber/baffle access door [A].

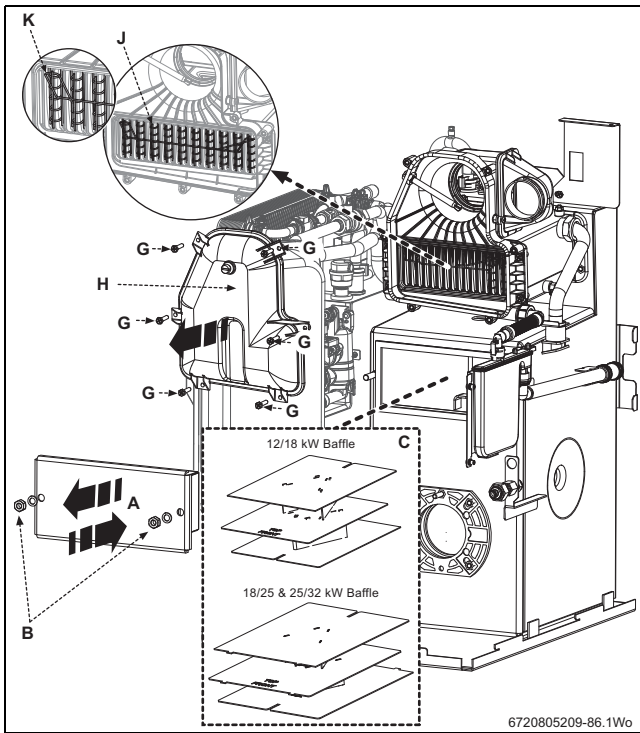

Fig. 27

- ▶ Ensure one piece baffle set [C] is in the right location [D], correctly resting on the baffle rests [F] on either side of the combustion chamber and pushed securely into place.

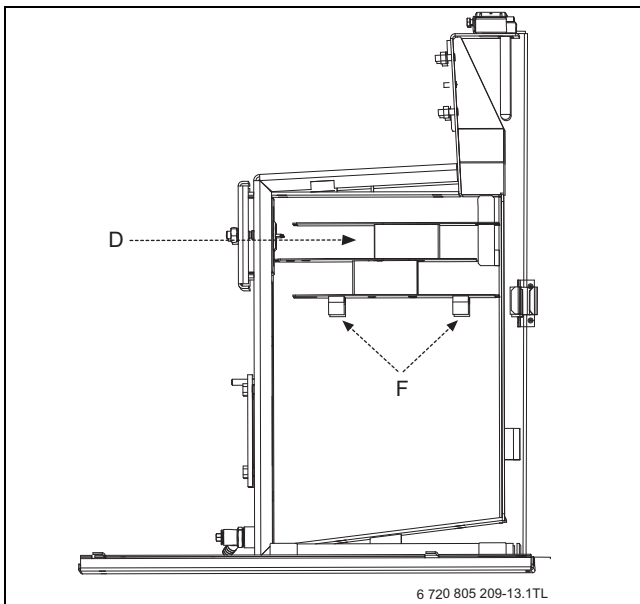

Fig. 28

- ▶ Refit combustion chamber door [A].



Secure with nuts and washers [B] and tighten until the chamber door is firmly secured, do not over tighten the nuts.

5.6 Pipework connections



CAUTION: Isolate the oil & water mains supply before starting any work and observe all relevant safety precautions.

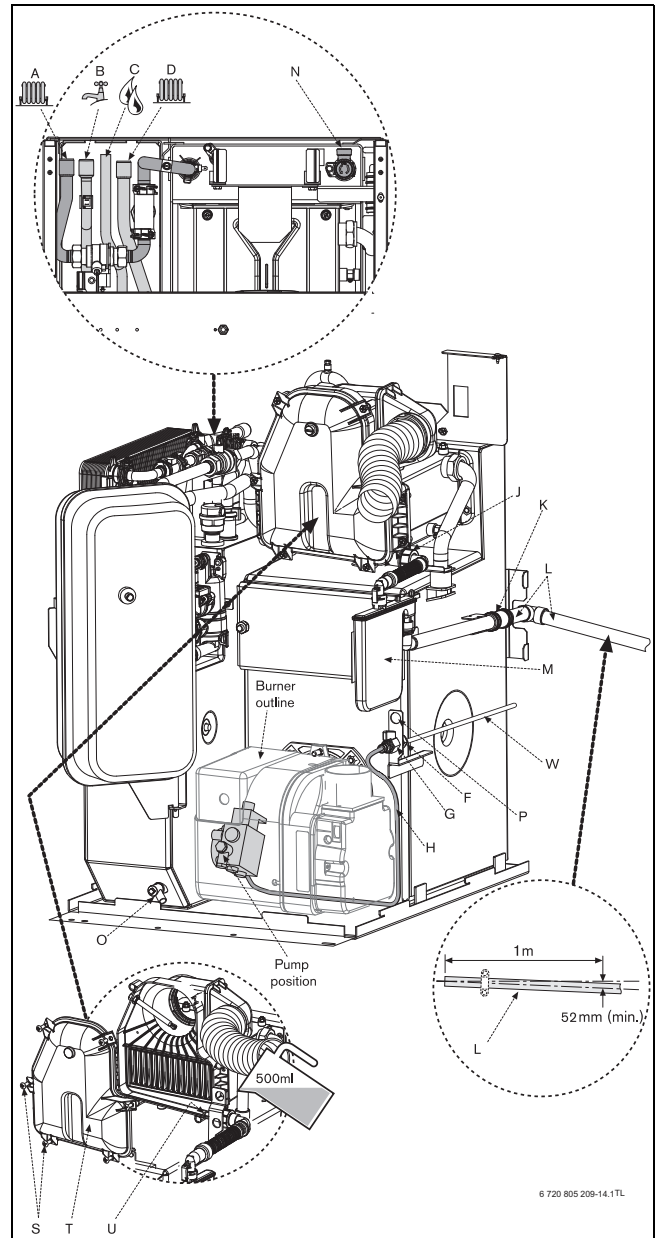

Fig. 29 Pipe connections

- [A] CH flow 22mm Ø copper (28mm Ø on 25/32 models)
- [B] DHW flow 22mm Ø
- [C] DHW water main inlet 15mm Ø
- [D] CH return 22mm Ø copper (28mm Ø on 25/32 models)
- [F] 10mm Ø oil supply connection
- [G] Oil isolating valve (10mm Ø)
- [H] Flexible oil hose*
- [J] Flue manifold condensate outlet
- [K] Condensate outlet and flexible push fit connect (21.5mm Ø) - supplied
- [L] Condensate pipe - not supplied
- [M] Condensate trap - supplied
- [N] Pressure relief (15mm Ø)
- [O] Drain
- [P] Fixing point for optional return oil pipe

Installation

Water connections

- ▶ Ensure all pipework is clean.



That surplus water may be present due to factory testing.

- ▶ Align water pipework and connect
- ▶ Check that all unused sockets have been capped.

Oil supply connections

- ▶ Route the oil supply pipe [W] along either side of the boiler as required and connect to the isolating valve [G] and ensure the valve is closed.



Replace flexible hose at annual service to prevent possible oil leakage.

- ▶ Connect the flexible oil hose [H] to the isolating valve [G].

Condensate connection

- ▶ Connect 21.5 mm polypropylene pipe [L] (not supplied) to the condensate waste pipe flexible push fit connector [K] and terminate to waste.
- ▶ Do not use any solvents, adhesives or lubricants when pushing the pipe into the rubber connector [K].
- ▶ Ensure that the condensate pipe runs away from the boiler at a constant fall of 52mm (min.) for every metre.
- ▶ Seal all condensate pipe joints.
- ▶ Carefully pour 500ml of water into the condensate collection [U] to fill condensate trap.
- ▶ Check the water is running away and the condensate pipework joints are water tight.
- ▶ Check the flue manifold seal is undamaged and seated correctly.
- ▶ Refit flue manifold access cover [T] and secure with screws [S].



The condensate trap must be correctly filled to prevent the possibility of potentially harmful flue products escaping via the condensate pipework.

Pressure relief connection

- ▶ Connect the pressure relief pipe [N] to a copper discharge pipe (15mm Ø min.).

5.7 Oil burner and pump



CAUTION: MAINS SUPPLIES

- ▶ Isolate the oil & water mains supply before starting any work and observe all relevant safety precautions.

Oil burner

1. Check that the nozzle (A) and the electrode (B) alignment settings are correct as shown in figure 30.
- ▶ Ensure that the nozzle (A) is aligned centrally within the combustion head (C).
 - ▶ Inspect for any visible defects.



NOTICE: IMPORTANT INFORMATION

- ▶ Before removing or fitting a nozzle (A), loosen screw (6 figure 31) and move the electrodes (B) forward. After refitting check that the electrode gaps are correct, as shown in figure 30.
- ▶ Whenever replacing the combustion head, ensure that the photocell is lined up with the sight hole.
- ▶ The 12/18 model has a brass deflection washer and locating circlip behind the nozzle. These must be in place for the correct operation of the burner.

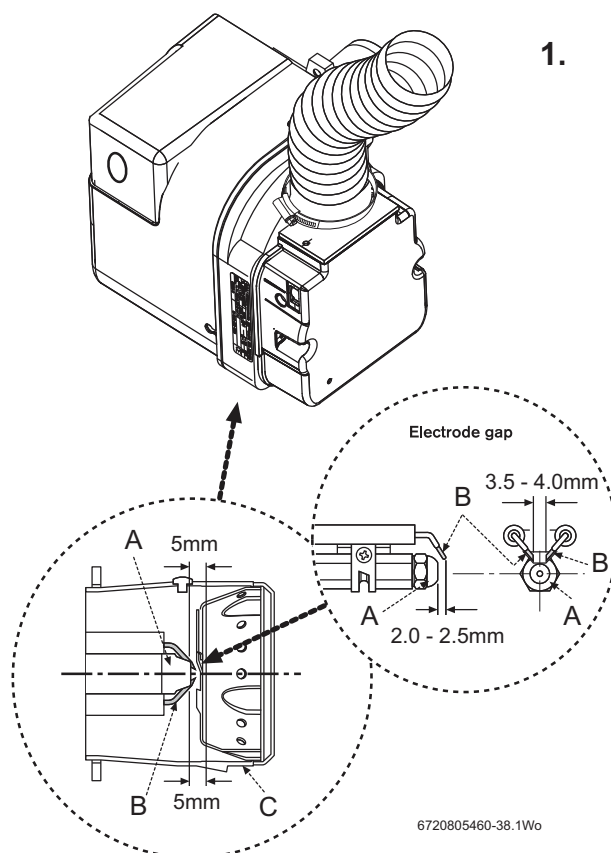

Fig. 30 Nozzle and electrode alignment

Oil pump

Connecting the oil pump for a single pipe system:

- ▶ The pump is factory set for single pipe operation with the flexible oil pipe fitted.
- ▶ Check connections before use.

Converting the oil pump for a double pipe system:

1. Check the inlet pipe connection (1).
 - ▶ Unscrew return plug (2).
 - ▶ Screw in by-pass screw (3) which is attached to the oil pump.
2. Connect the flexible oil pipe return hose (not supplied) to the oil pump and return pipe fixing and tighten to secure (for routing see figure 29).

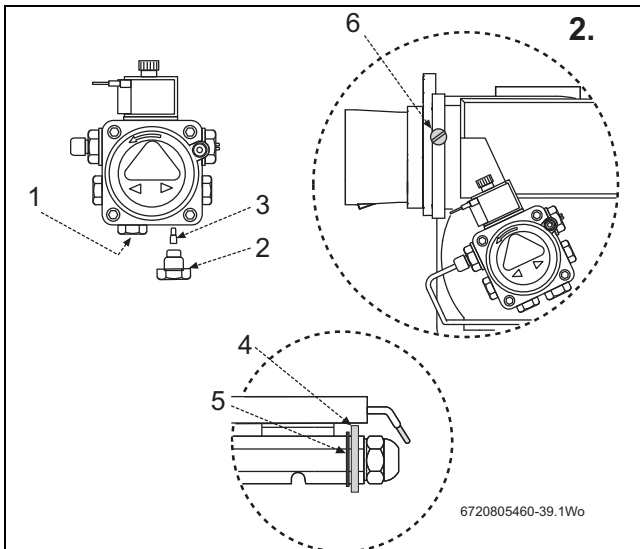

Fig. 31

- [1] Inlet pipe connection
- [2] Return plug
- [3] By-pass screw
- [4] Brass air deflector washer (12/18 models only)
- [5] Locating circlip
- [6] Electrode fixing screw

5.8 Refitting components

1. Align burner combustion head into the boiler collar.
 - ▶ Locate the burner retainer [A] over the threaded lug on the collar [B], push the burner firmly into the flange and secure in place with the retaining nut [C]. Tighten sufficiently but do not over tighten.
 - ▶ Check that the burner is seated correctly on its mounting flange and that the oil hose/s are routed correctly as shown on page 19.

NOTICE: Ensure the o-ring seal between the burner collar and mounting flange is in good condition to prevent flue gases escaping from the combustion chamber into the cabinet.

2. Refit the flexible air duct and secure with clip [D].
3. Plug burner lead [F] into connector [G].
4. Swivel the expansion vessel [H] back into position taking care not to kink the flexible hose or snag electric cables.
5. Refit control box.
 - ▶ Rotate the box towards you [J].
 - ▶ Slide control box drawer back into position.
6. Refit the top panel and press down to compress the seal when fitting the securing screws [K].
7. Push the front panel [L] up behind the top panel and push in at the base to secure with the screws [M] using the tool provided. Always apply pressure at the edges of the boiler panels when securing to avoid accidental damage.

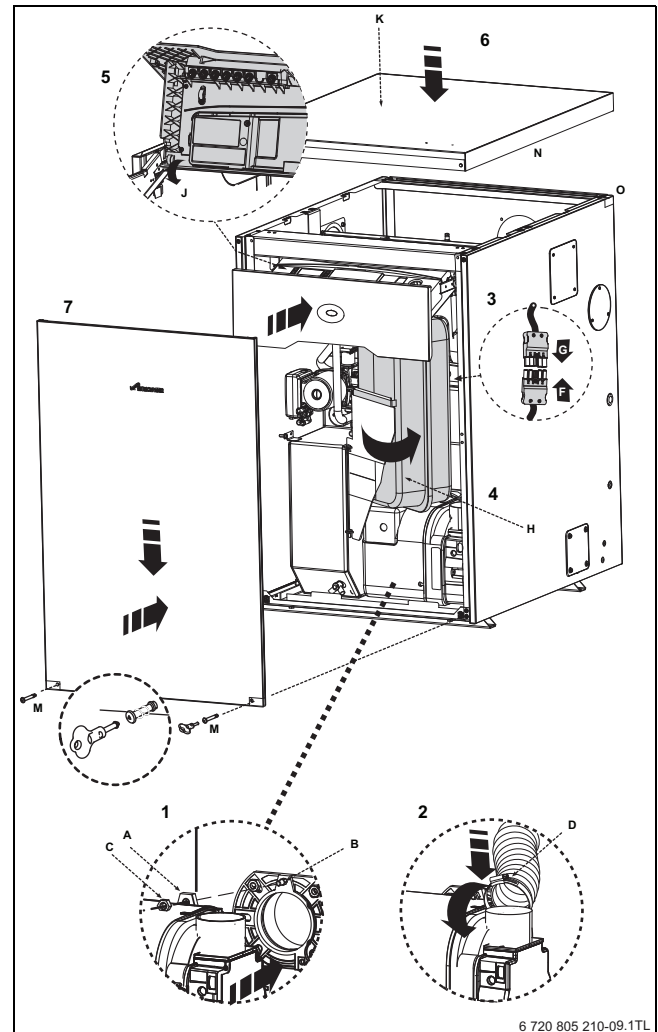

Fig. 32

5.9 Electrical

DANGER: 230 Volts
Isolate the mains electricity supply before starting any work and observe all relevant safety precautions.

NOTICE: This appliance provides a permanent external electrical supply for servicing and must therefore be fed via a circuit breaker incorporating earth leakage protection.

NOTICE: Follow electro-static discharge precautions. do not touch the PCB circuits or components.

WARNING: External equipment operated at 230 volts should not be serviced or repaired under adverse weather conditions.

- The boiler is pre-fitted with a mains supply cable and plug [A].
- The 230V supply to the boiler must be wired to the socket provided [B].
- The mains electrical supply to the boiler must be through a fused double pole isolator and must have earth leakage protection.
- The isolator must have a contact separation of 3mm minimum in both poles.
- Any additional equipment connected to the boiler must not have a separate electrical supply.
- External fuse rating 5 A.

NOTICE:
When wiring mains and control cables ensure that the cable has sufficient length for the control box to be slid forward and tilted over.

Access to electrical connections

Access to all wiring connections are via the Installer access cover at the bottom front of the control board.

1. Release the 3 captive screws [C] and remove the Installer access cover [D].

Electrical connections

2. E. Low voltage connections.
G. Mains voltage connections.
H. Fuse carrier.

i DHW LR switched live: This input provides the live feed in from a connection for a proprietary twin channel control to time the tank reheat function on the DHW. All Worcester twin channel digital controls provide this functionality, but the link is required for them to function.

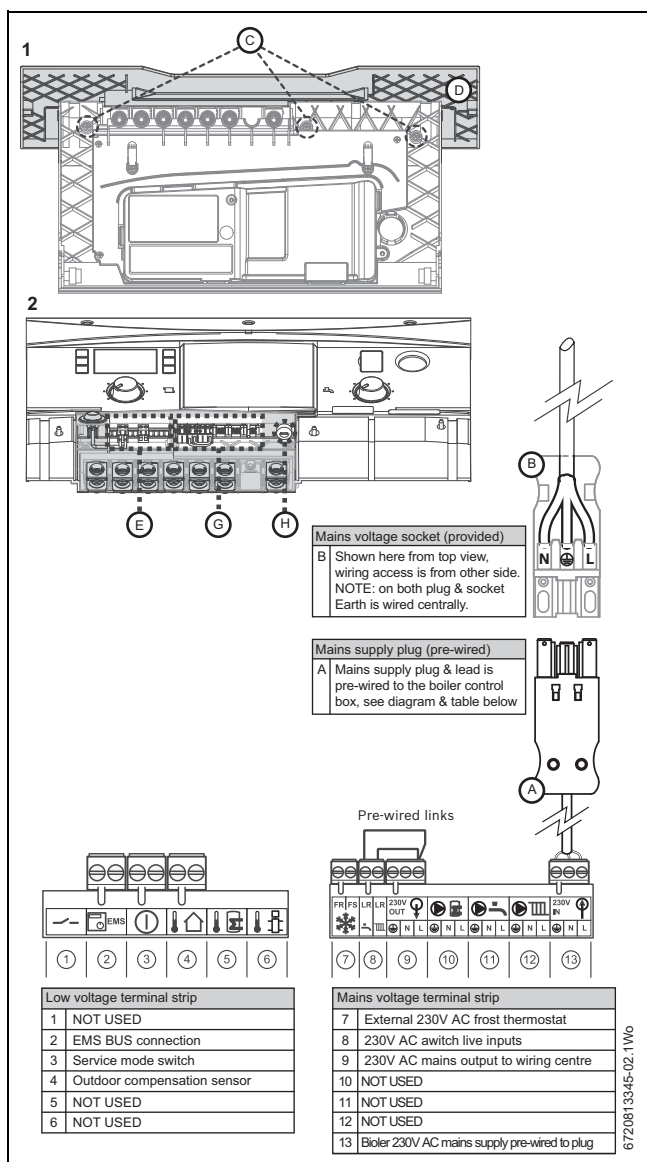

Fig. 33

DANGER: 230 Volts
Isolate the mains electricity supply before starting any work and observe all relevant safety precautions.

Frost protection

The boiler has built in frost protection to protect the appliance and the system within the heated building.

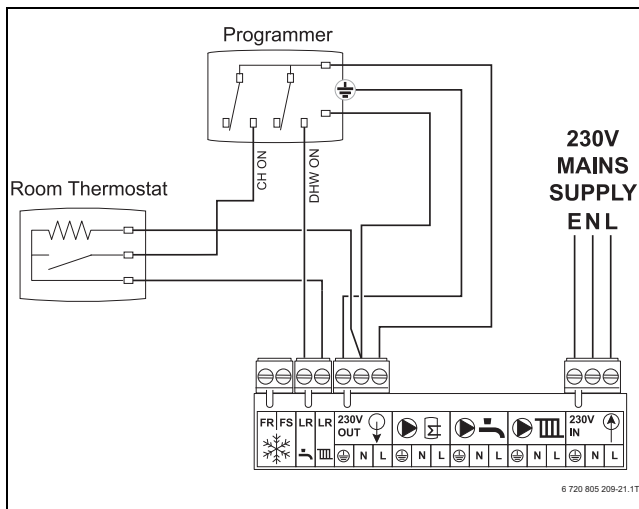

Fig. 34 External 230 V Twin Channel Programmer and Room Thermostat

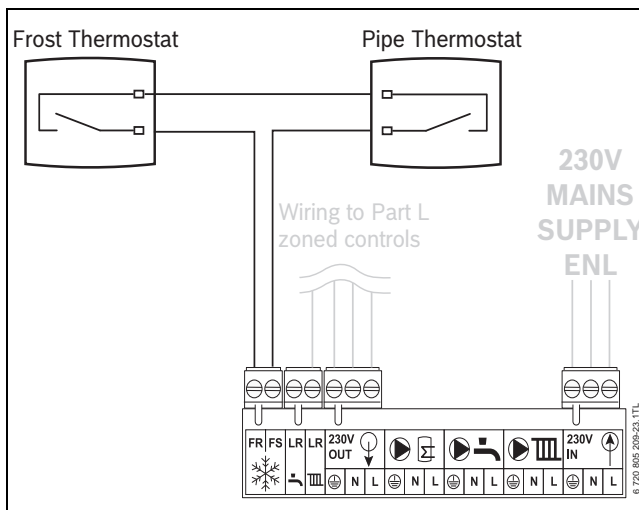
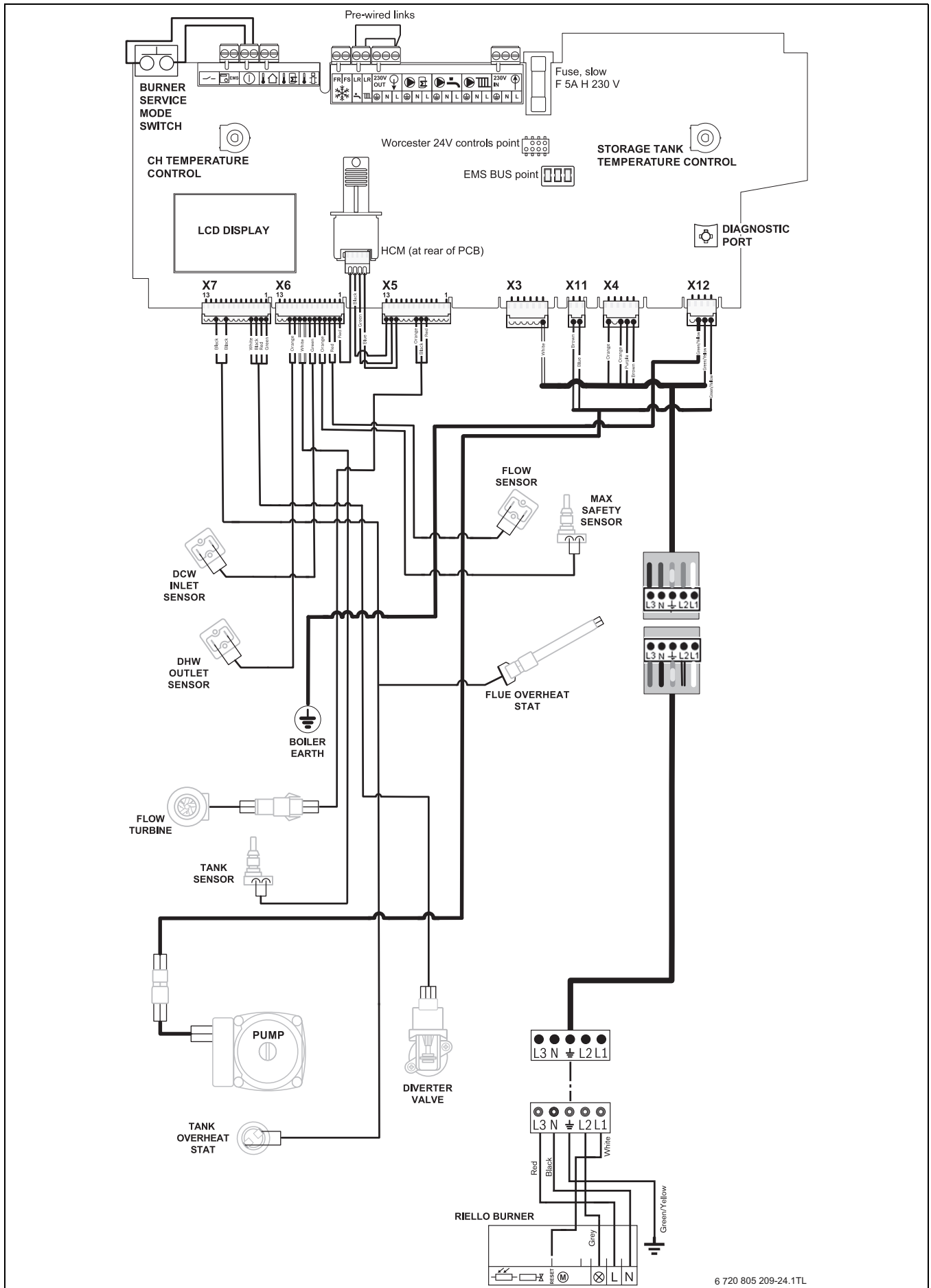

Fig. 35 Optional External 230 VAC Frost Stat Connection for protection of system pipework in unheated air space

- Connect frost thermostat cables to terminals FS & FR.
 - These connections are not polarity sensitive.
 - The Boiler internal frost protection will bring on the burner if required.

5.10 Electrical schematic



6 720 805 209-24.1TL

Fig. 36

5.11 Weather compensation

The appliance will modulate the CH flow temperature based on the outside temperature when an outdoor sensor is connected to the outdoor sensor connection on the control board and the weather compensation is active.

This is designed for use with a system that has thermostatic radiator valves and a room thermostat.

The appliance will operate at lower temperatures when there is a lower heat load because the building is losing less heat due to higher external temperatures. This means that the appliance is running more efficiently as it is operating for longer at condensing temperatures.

The weather compensation curve can be adjusted to tune the flow temperature to suit the particular installation.

The appliance is supplied with the weather compensation deactivated.

Weather compensation activation

The weather compensation is activated via menu 1 of the text display.

- ▶ Select Menu 1 via ▲▼ scroll buttons.
- ▶ Press OK button.
- ▶ Select W1 via ▲▼ scroll buttons.
- ▶ Press OK button.
- ▶ Set W1 to 1 via ▲ scroll button.
- ▶ Press OK button.

The weather compensation is now active and the appliance will check for the presence of an outdoor sensor and deactivate the CH flow temperature modulation if a sensor is not detected. When weather compensation is activated but an outdoor sensor is not fitted/detected, the warning triangle and H03 will be displayed on the LCD display.

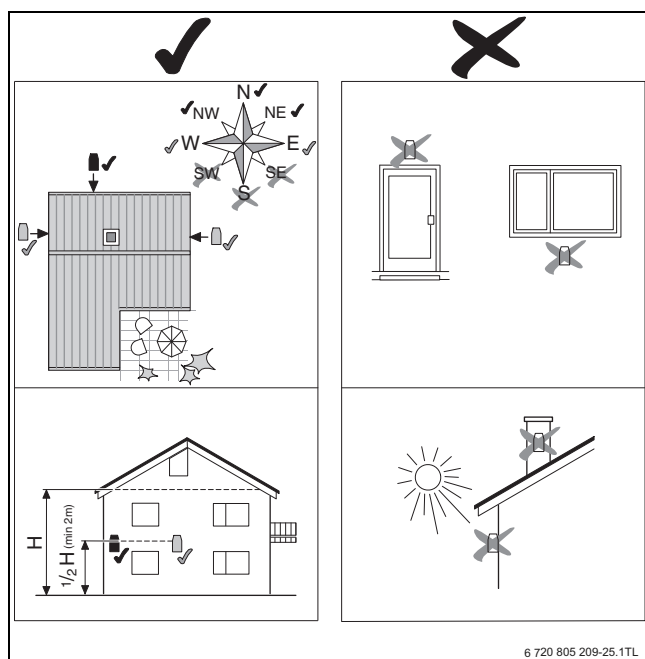

Fig. 37

Weather compensation sensor optimum siting indicated by black tick.

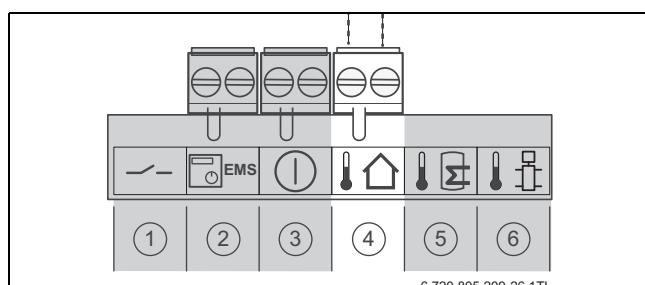

Fig. 38

The sensor is wired directly into the control box via terminal 4 in the low voltage terminal strip (→ page 22).

The heating curve

The CH flow temperature has an upper limit of 82°C (this can be capped via the CH control knob setting) and a lower limit of 50°C, (it is recommended that the CH knob is set to 82°C for the weather compensation to operate most effectively).

The default settings for the curve are point A = 90°C and point B = 40°C, this gives a 80°C flow at -4°C outdoor temperature and a 50°C flow at 14°C outdoor temperature which should be suitable for typical systems.

Point A is the projected value for the flow temperature at -10°C outdoor temperature and point B is the projected value for the flow temperature at +20°C outdoor temperature, (these values dictate the angle of the slope only they are not CH flow temperature limits).

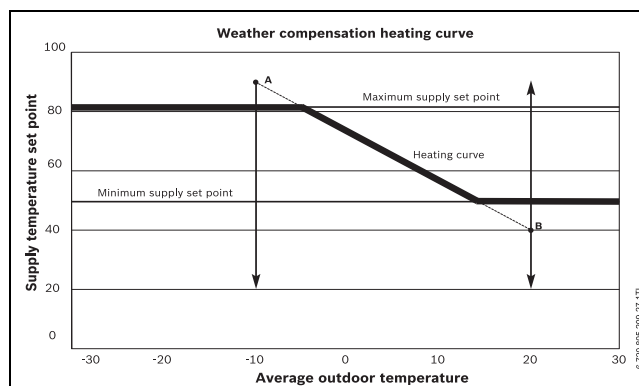

Adjusting the heating curve

- ▶ The weather compensation curve can be adjusted via the text display by adjusting the projected flow temperature at -10°C (point A), Menu 1 W2 (pA), and 20°C (point B), W3 (pB), enabling the slope as well as the position of the curve to be adjusted to suit the installation.
- ▶ Point A and B can be set between 90 and 20°C but point A must always be greater than point B.

Outdoor sensor error

- ▶ If during weather compensation the outdoor sensor is open circuit or closed circuit the CH flow temperature modulation is deactivated and the CH flow temperature set to the CH control knob setting, a warning triangle and H03 are displayed on the LCD.
- ▶ The appliance will monitor the outdoor sensor input and if the sensor returns to normal then the flow temperature modulation will be reactivated and the LCD warning triangle and H03 are turned Off, (there may be a 10 second delay).

Average outdoor temperature

- ▶ To stop rapid fluctuations the outdoor temperature used for CH flow temperature modulation is an average value taken over a ten minute period.
- ▶ When an outdoor sensor is first detected the sensor value is taken to be the outdoor temperature, subsequent to this the outdoor temperature will be adjusted every 10 minutes using an average outdoor temperature value from the previous 10 minute period.

Frost protection

The normal condition for the appliance is that the weather compensation frost protection is turned Off.

If required the frost protection is activated via Menu 1 W5 of the text display, 0 = OFF, 1 = ON.

On Activation of the weather compensation frost protection if the outdoor temperature is less than 5°C the system frost protection is activated the same as if an external frost thermostat was activated.

6 Commissioning

6.1 Pre-commissioning checks-appliance



CAUTION: Isolate the mains supplies before starting any work and observe relevant safety precautions.

1. Check that the service and water pipes are connected correctly.
 2. Check that the oil supply is Kerosene and that the pipework is connected correctly to the oil pump via the supplied flexible oil hose (→ correct routing for flexible hose on page 19).
- Turn on the main oil supply valve at the tank, check the oil supply pipework and connections. Rectify any leaks.



Replace flexible hose at annual service to prevent possible oil leakage.

1. Check the flue is correctly fitted and the connections are secure.
 2. Check the condensate pipework is correctly fitted and connected.
- Check the condensate trap is filled with water.
5. Check the CH circulating pump is set to 3.



The CH circulating pump is preset to number 3 and should not be altered.

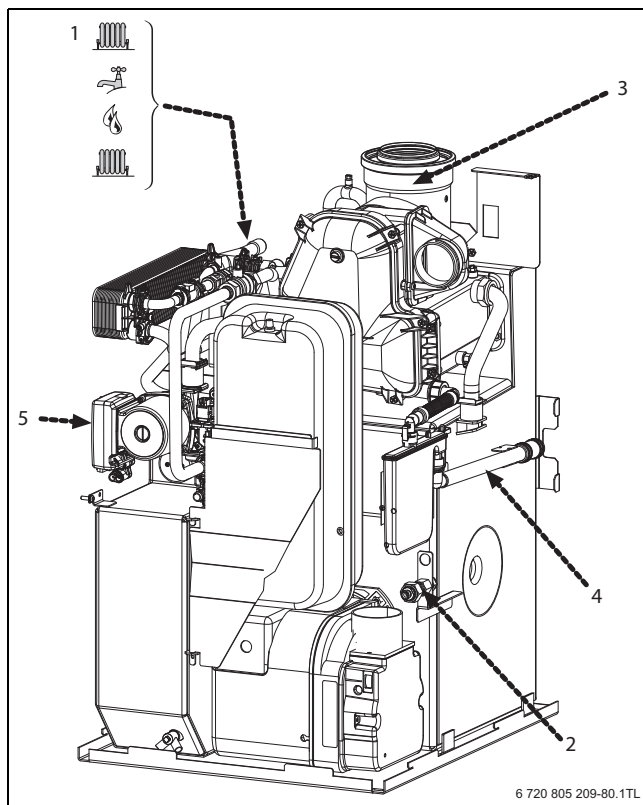

Fig. 39



NOTICE:

If the boiler is not to be commissioned immediately then: After successfully completing all of the checks and any rectification work, close the water valves, shut off the oil supply and electrically isolate the boiler. Complete the installation part of the Guarantee Registration Card, and complete a CD10 or equivalent to inform the LABC of the installation.

6.2 Filling the system

1. The diverter valve will sit in mid-position when the boiler has no demand and is powered up.

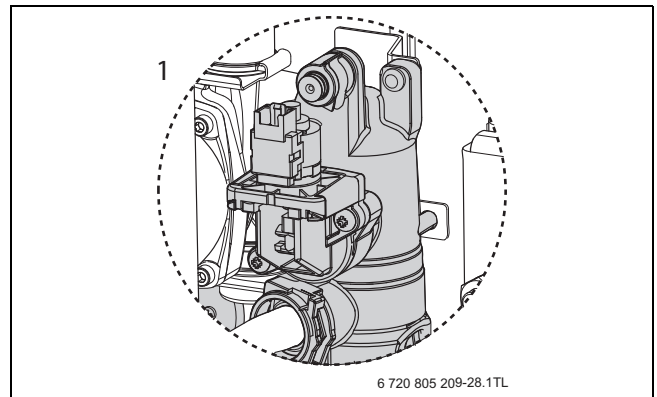

Fig. 40

2. Loosen the flow pipe manual air vent screw.

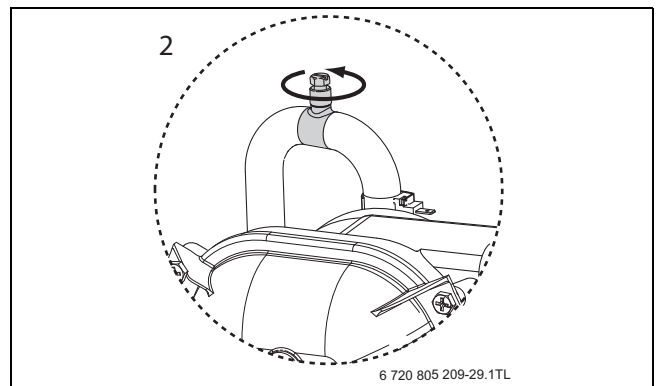

Fig. 41

3. Check and if required, adjust the expansion vessel pressure using the Schraeder type valve [A].

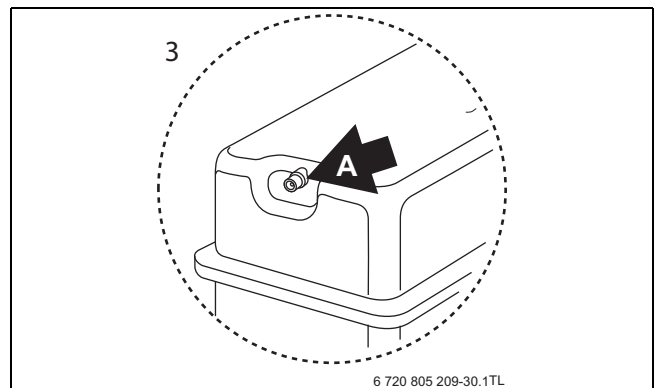

Fig. 42

The charge pressure of the built-in 12 litre expansion vessel is 0.7 bar as dispatched, which is equivalent to a static head of five metres. At 1 bar pressure the vessel will provide 107 litres expansion capacity, the boiler has a primary water capacity of between 62 and 64 litres and therefore additional system expansion capacity may be required.

Total system volume (litres)	Initial system pressure (bar)	Initial charge pressure (bar)
180	0.5	0.5
107	1.0	0.5
138	1.0	1.0

Table 6

If an extra expansion vessel is fitted to the central heating return, adjust this to the same pressure as the appliance internal expansion vessel, refer to separate instructions supplied with the extra expansion vessel.

- Open all system and radiator valves.
 - Turn on the water main stop cock.
 - Close the flow pipe manual air vent when water is vented.
 - Fill the system to between 1 and 2 bar pressure via a WRAS approved filling link. Monitor the pressure gauge during venting and repressurise if required.
 - Check air is being discharged from the automatic air vents.
 - Vent all radiators, retighten when completed, check the system and correct any leaks.
 - Bleed air from both of the secondary heat exchanger air vents [B] and flow pipe air vent.
 - Bleed air from the pump using the pump bleed screw.

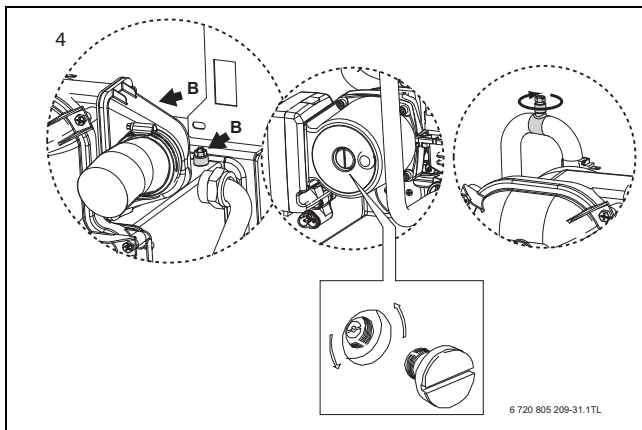

Fig. 43

- Connect a suitable hose to the Heatslave tank drain. Open the drain valve to reduce the system to the correct pressure, then close the drain valve. Ensure safe disposal of the discharge.

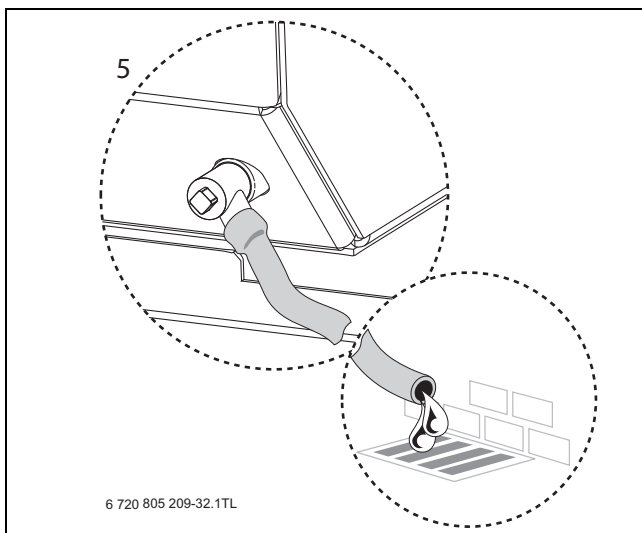

Fig. 44

- Check system and rectify any leaks.

6.3 Starting the appliance



NOTICE:

Never run the appliance when the appliance/system is unpressurised or empty.

- Check the oil supply is correctly fitted, pressure tested and in good working order before turning on the oil supply valves to the boiler.
 - Turn on the main oil supply valve at the tank and draw off at least 2.5 litres of oil until a steady flow of clear uncontaminated oil can be seen as follows:
 - The oil supply to the boiler should be primed before the burner is operated to avoid unnecessary pump wear.
 - The use of an oil suction pump will prime and flush through any oil supply set up simply and easily, alternatively the following procedures can be used.

Single pipe gravity feed systems:

- Disconnect the flexible oil hose and open the isolating valve to discharge the oil into a suitable container.



Replace flexible hose at annual service to prevent possible oil leakage.

- If a top entry tank has been used the pipework will need to be primed before the oil will discharge under gravity.
- When completed, close the isolating valve, reconnect the flexible oil hose.

Double pipe sub-gravity feed systems and single pipe suction lift with de-aerator:

- Turn on the boiler, the oil level in the de-aerator will drop as the oil is used until the oil is drawn from the tank. If the de-aerator empties and the burner locks out before the oil is drawn from the tank, prime the de-aerator again.
- To prime a de-aerator, disconnect the flexible oil inlet hose [E] from the isolation valve and place in a container of Kerosene [G]. Connect a spare flexible oil hose [H], to discharge into container [G]. Open the isolating valve, turn on the power to the boiler and set the programmer to ON. Prime the de-aerator until there is a steady flow of oil into container [G]. Turn off the boiler then reconnect the flexible oil inlet hose [E].

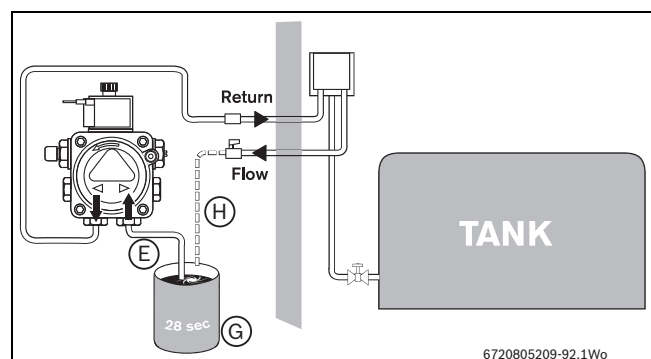

Fig. 45

When the oil reaches the pump, bleed the air from the pump as follows

- Open the isolating valve and the oil pump bleed port [A] to discharge into a suitable container once the boiler is started up.
- Switch on the electricity supply to the boiler.
- Set the programmer to ON for CH and DHW.
- Turn on the boiler CH control thermostat.
- Allow the burner to run through to lockout indicated by the control panel LCD display [J] showing code 9F 855.

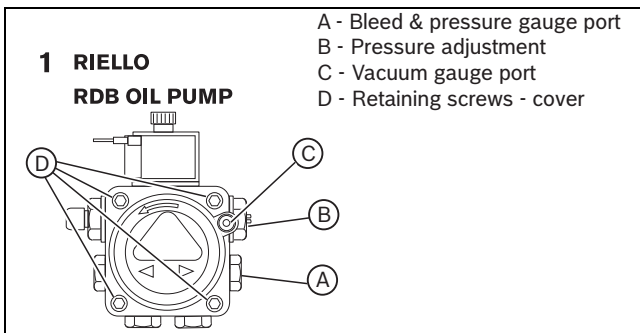

Fig. 46

If no oil comes out of the port valve A, then re-prime the oil line as detailed above

- ▶ Wait 2 minutes then press the lockout reset button [K].
- ▶ Repeat the procedure until a steady stream of oil without air, runs from the bleed port, then lock bleed port [A].
- ▶ Switch off the boiler.

Clean the oil pump filter



If debris is found, then the oil supply system must be checked for the source of debris before the boiler is commissioned.

- ▶ The internal filter is accessed by removing the oil pump cover
- ▶ Remove the oil pump filter, clean with Kerosene and refit
- ▶ Safely dispose of the container/discharge

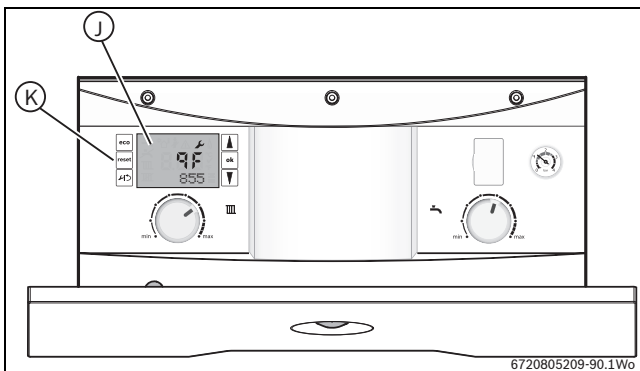

Fig. 47

2. Fit a suitable pressure gauge to port [A] on the oil pump.



NOTICE:

If changing the burner output, ensure the position of the air damper disk is correct for the desired output. Refer to table 8.

- ▶ **12/18 & 18/25 - RIELLO RDB 2.2**
Adjust position of the air damper disc to suit the burner output (→ table 8 on page 30), located as shown in figure 48. Access is by loosening the two star screws (SC) to release the air inlet manifold.
- ▶ **25/32 - RIELLO RDB 2.2**
No damper disk is fitted to the 25/32kW burner.
- ▶ Adjust the air shutter [L] (see figure 48) and pump pressure [B] as shown in figure 46. The burner should ignite following a pre-ignition period of approximately 15 seconds.



The MO535 MRF control box has an 3.5 second delay before the start of the pre-ignition.

Boiler lockout

If the burner fails to establish a normal firing pattern or flame failure occurs the flame monitoring photocell mounted in the burner body will alert the burner control box to shut the burner down and provide a safe

lockout state indicated on the control panel LCD display [J] by code 9F 855.

- ▶ Wait two minutes then press the lockout reset button [K] to initiate another start sequence.
- ▶ Repeat procedure until a flame is established.

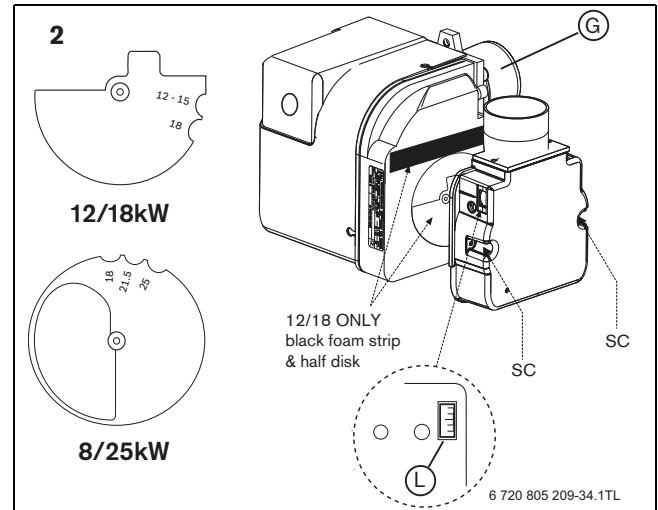

Fig. 48

3. Start and run for 3 minutes then switch off.

- ▶ Check for after-spurting from the nozzle, indicated by oil saturation on the combustion head [G].

If after-spurting occurs:

- ▶ Release the burner retainer nut [H].
- ▶ Remove the burner, combustion head [G]. and electrodes, hold the burner vertical to unscrew the nozzle and fill the nozzle holder with oil.
- ▶ Refit nozzle, electrodes, combustion head [G] and the burner.
- ▶ Restart and run for 3 minute intervals until after-spurting stops.

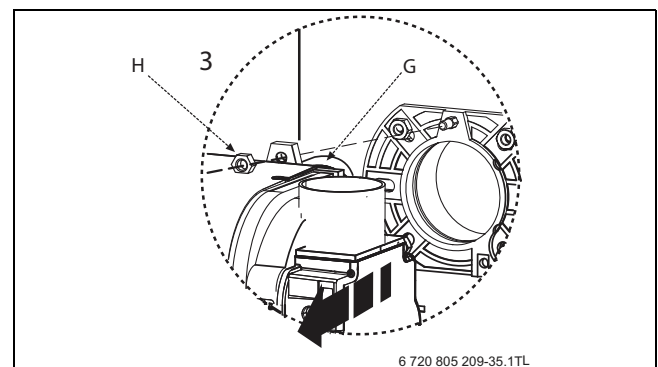

Fig. 49

1. Start and run for 20 minutes.

- ▶ Check that the oil pressure is set according to table 8 on page 30
- ▶ Remove sampling point plug [J] to check the smoke reading is between 0-1. If the smoke level is above 1, check the combustion settings are correct and the oil nozzle is in good condition.

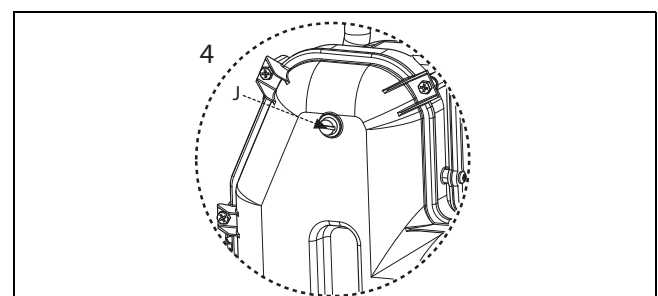

Fig. 50



Smoke readings may be inaccurate until the smoke from burning organic binder in the access door insulation has ceased.

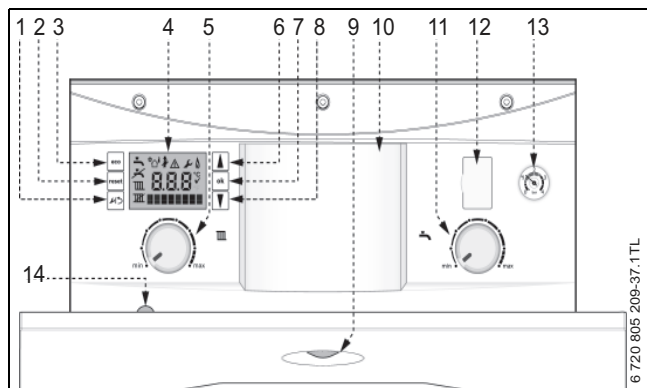

Fig. 51

Control board:

- [1] Spanner/return button
- [2] Reset button
- [3] ECO button
- [4] Boiler LCD display
- [5] Central heating temperature control
- [6] Scroll up button
- [7] OK - Select/confirmation button
- [8] Scroll down button
- [9] Operation and fault indicator (blue)
- [10] Position for optional programmer
- [11] Hot water temperature control
- [12] Diagnostic port
- [13] System pressure gauge
- [14] Burner service mode button

Switching the appliance on/off

- ▶ Turn on the mains power supply, initially the “Boiler start up screens” will be displayed (see figure 52:)
- ▶ Turn on any external controls.
- ▶ Set the thermostatic radiator controls to maximum.
- ▶ Set the clock/programmer to continuously ON and the room thermostat to maximum temperature

The blue operation/fault indicator light will be illuminated when there is a demand for heat or hot water.

- ▶ Turn the boiler CH temperature control [5] to maximum.

If the boiler fails to light, a flashing fault code will be displayed.



Do not press the blue operation/fault indicator [9] to reset the boiler.

- ▶ To reset the boiler, press the reset button [2], the “tick” symbol will be displayed briefly for a successful reset.

Boiler start up screens

On initial start up, the following screens are displayed:

1. All the symbols are displayed for approximately 2 seconds.
2. The control will run an internal test.
3. When the internal test has been successfully performed, this screen is displayed:
 - ▶ The boiler is in stand-by.
 - ▶ The flow temperature sensor indicates the primary temperature from the heat exchanger (not the target set point).
4. If no adjustments are made for 30 seconds, the back light goes off.
- ▶ As soon as an adjustment is made, the screen will light up and the relevant information will be displayed.

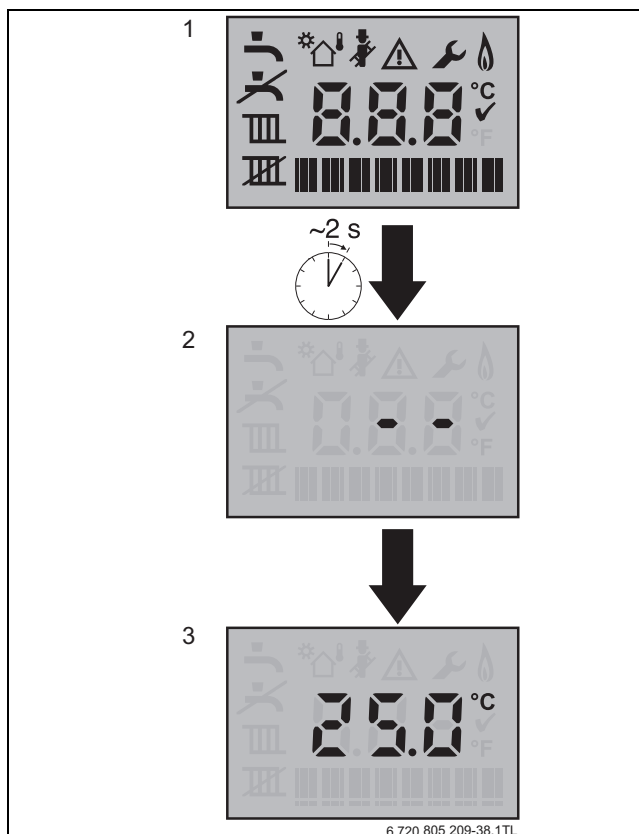

Fig. 52 Start up screens

Screen display

All possible screen symbols are displayed briefly during start up. Extended diagnostic features have rendered the greyed out symbols not required for the operation of this appliance.

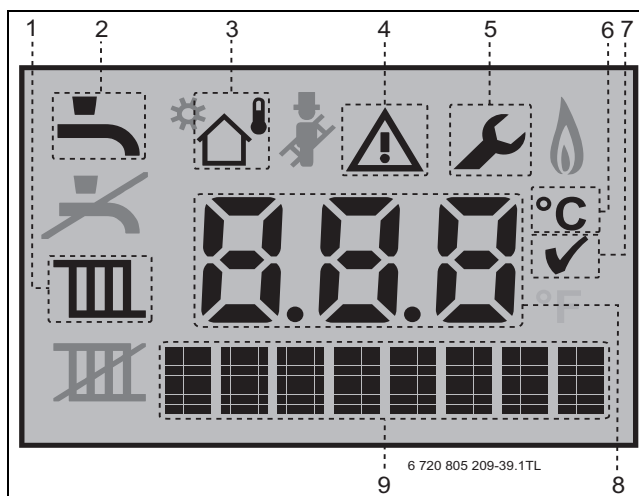



Fig. 53

- [1] **Central heating symbol**
Displays this symbol during CH demand.
- [2] **Hot water symbol**
Displays this symbol during DHW demand (DHW flow rate > 2 litres per minute) and tank reheate.
- [3] **Weather Compensation active symbol**
Displays this symbol only if a Weather Compensation sensor has been fitted to the appliance and is active.
- [4] **Alert symbol**
Displays with the boiler status code and diagnostic code during a fault condition.
- [5] **Service mode symbol**
Displays when in the service menu.

- [6] **Centigrade symbol**
Displays next to the temperature reading.
- [7] **Confirmation symbol**
This symbol confirms a manual change.
- [8] **Alpha/Numerical display**
Displays a temperature or boiler status code.
- [9] **Text display**
Displays ECO or diagnostic code.

Status code

 During normal operation various status codes can be displayed by pressing the service button.

The first screen of the information menu displays the current status code, this will change as the boiler runs through the various modes and sequences.

These are not faults, but provide information concerning the current status.

Status Code		
200	CH active	The Central Heating system is being heated.
201	DHW active	The Domestic Hot Water is being heated/ tank is being heated.
202	CH Anti rapid-cycle mode	Time delay to prevent rapid-cycling of the boiler on the room thermostat.
203	System stand-by	The boiler has no CH or DHW demands.
270	Power up mode	The boiler is ON, warming up and running self check routines. This lasts approximately 35 seconds.
358	Three way valve anti-seize	Anti-seize operation. If the diverter valve has not moved in 24 hours, the valve is operated to prevent seizing, duration approximately 10 seconds.

Table 7

Selecting Service Menus

1. Press and hold  and  buttons together for 1 second, the display will show Menu 1.

Double up or down arrows  indicate that the menu can only be scrolled up or down.

An up and down arrow  indicates position in the menu where options can be scrolled either up or down.

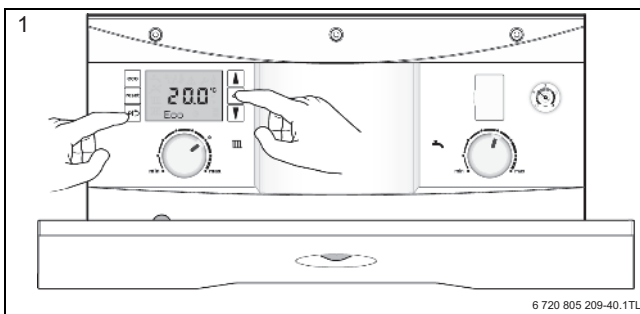



Fig. 54

2. Scroll up and down through the menus with the arrow buttons  

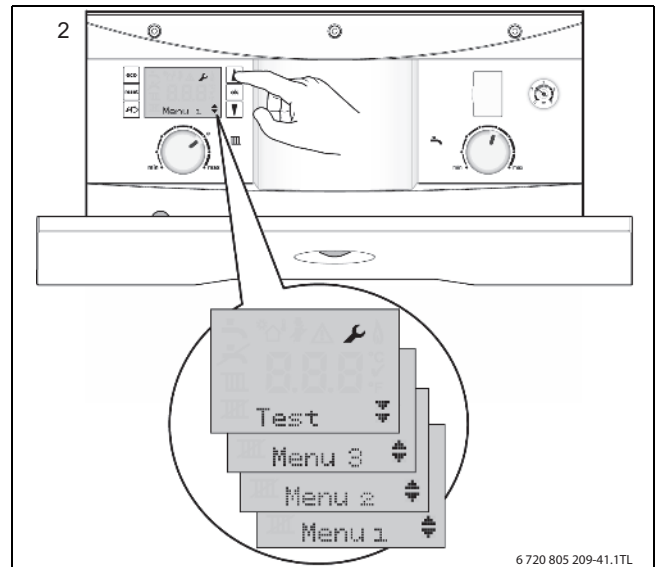

Fig. 55

Menu 2 - Boiler parameters

3. Select Menu 2 via the  and  arrow buttons.

▶ Press and hold  OK button, for 1 second to enter Menu 2.

The menu lists the boiler parameters, that can be adjusted in this menu.

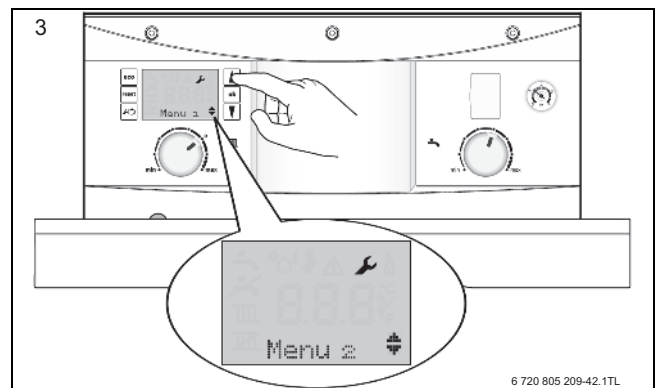



Fig. 56

To modify setting

4. Select the desired menu option using the arrow buttons (refer to the table below) and press the OK button, the option will flash.

▶ Adjust the parameter using the up and down arrow buttons and press the OK button to confirm.

A tick  will appear on the display for 3 seconds to confirm the update of the new value.

The same process is used for adjusting Menus 1 & 2.

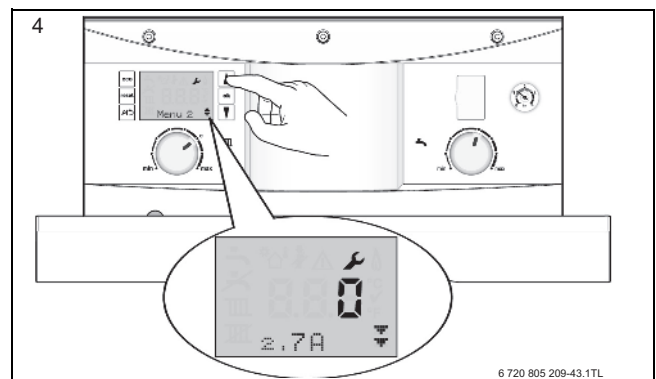

Fig. 57

Commissioning

Menu 2 parameter

2.7A Demand /fault indicator (blue light) activation	0 = The blue light will only operate as a flashing fault alert.
	1 = The blue light will operate as a boiler demand light and fault alert. This is set to 1 by default.

Reset to factory settings

To reset any or all changes made in Menu 2 back to the factory default setting:

i Any changes made to Menu 1 are not reset by these actions.

1. Press and hold the and buttons for at least five seconds. The screen will then display code BE and spanner symbol.

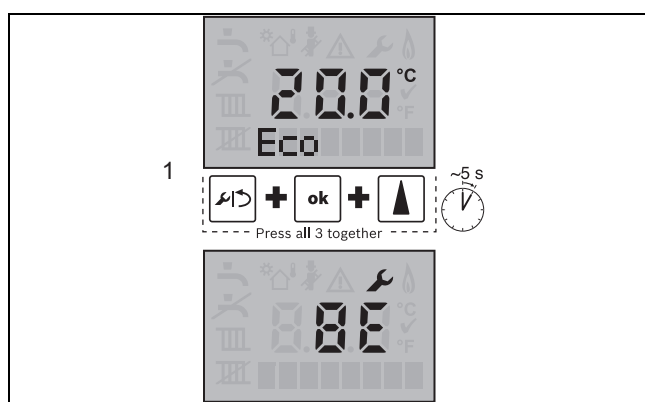

Fig. 58

1. Press the button and "reset" will be displayed with the tick symbol for three seconds. After three seconds the display will revert to the normal operation screen.

i APPLIANCE MUST BE SET TO CO₂ LEVELS.
Air settings are approximate, as flue length and nozzle variations will affect them.

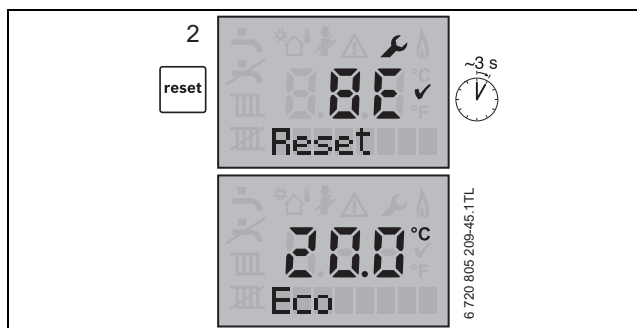

Fig. 59

Finish pre-commissioning boiler checks

- ▶ Check the CO₂ levels, refer to table 8 and adjust the air shutter [L].
 - ▶ Check the flue gas temperature is close to the values in table 8.
- If the flue gas temperature is too high and the baffles are correctly fitted, then reduce the oil pump pressure [B] 5-10 p.s.i. to compensate for nozzle variations.*
- ▶ Turn off the electrical supply.
 - ▶ Isolate the oil supply to the burner.
 - ▶ Remove the oil pressure gauge.
 - ▶ Refit the blanking plug [A].
 - ▶ Check and rectify any oil leaks.
3. Switch on the oil supply.
 - ▶ Switch on the electrical supply.
 - ▶ Restart the boiler and run for 5 minutes.
 - ▶ Recheck the CO₂ levels and if required, adjust the air shutter setting [D] to obtain the correct CO₂ level.
 - ▶ Refit the sample point cap (hand tighten only, do not over tighten) and refit the burner cover.
 - ▶ Complete the oil boiler commissioning checklist at the back of this manual.

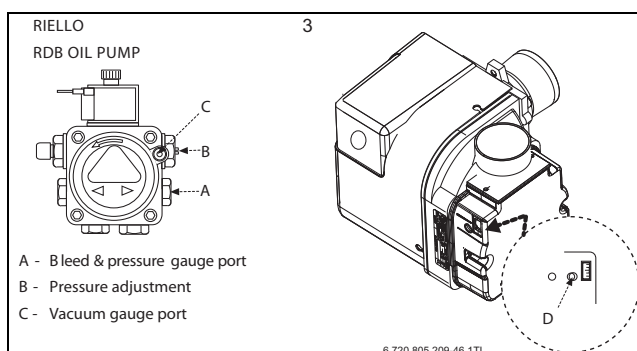

Fig. 60

Nominal boiler rating at normal operating temperature using Kerosene (Class C2)

Nozzle	Oil pump pressure		Fuel flow rate		Approximate flue gas temperature		Approximate air setting	Input (appliance) kW	Output (appliance) kW	Air damper disk setting	Burner head
	bar	psi	Kg/h	l/h	°C	%CO ₂					
Greenstar Heatslave II 12/18 model											
0.35 x 80° SR	9.0	132	1.04	1.32	72	11.0	3.0	12.4	12.0	12/15	LD2X Short
0.45 x 60° ES	7.5	110	1.28	1.63	77	11.5	5.0	15.4	15	12/15	LD2X Short
0.55 x 80° ES	7.8	115	1.54	1.96	80	12.0	5.0	18.5	18.0	18	LD2X Short
Greenstar Heatslave II 18/25 model											
0.50 x 80° ES	8.5	125	1.58	1.96	76	11.5	3.0	18.5	18.0	18	LD2SX Short
0.60 x 60° ES	8.5	125	1.84	2.33	81	12.0	3.5	22.1	21.5	21.5	LD2SX Short
0.75 x 80° ES	7.5	110	2.15	2.72	87	12.0	4.5	25.7	25.0	25	LD2SX Short
Greenstar Heatslave II 25/32 model											
0.75 x 80° ES	7.5	110	2.15	2.72	79	11.5	3.5	25.7	25.0	N/A	T2 Short
0.75 x 80° ES	10.0	147	2.46	3.12	81	12.0	4.5	29.4	28.5	N/A	T2 Short
0.85 x 80° EH	9.5	140	2.78	3.52	86	12.5	5.0	33.0	32.0	N/A	T2 Short

Table 8 Combustion settings

6.4 Water treatment

NOTICE:
Debris from the system can damage the boiler and reduce efficiency.
Failure to comply with the guidelines for the use of water treatment with the appliance will invalidate the appliance warranty.

Flushing (Central heating)

1. Switch off the boiler.
- ▶ Open all radiator valves/drain cocks [C] and drain the system while the appliance is hot.
- ▶ Close drain cocks [C].

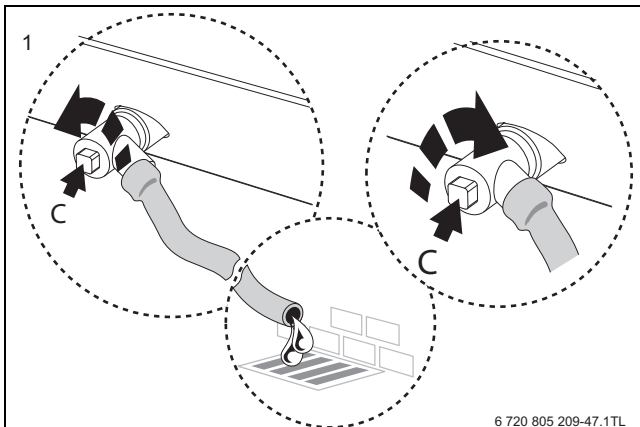

Fig. 61

2. Add a suitable flushing agent and refill the system at the correct strength for the system condition in accordance with the manufacturer's instructions.
 - ▶ Vent the boiler (there are two vent points [A] at the top of the secondary heat exchanger (only one may be in use, the other may be obscured by side fluing) and one on the flow pipe. Always vent [A] and the vent screw [B] on the pump and all radiators.
 - ▶ Run the boiler/system at normal operating temperature for the time stated by the flushing agent manufacturer

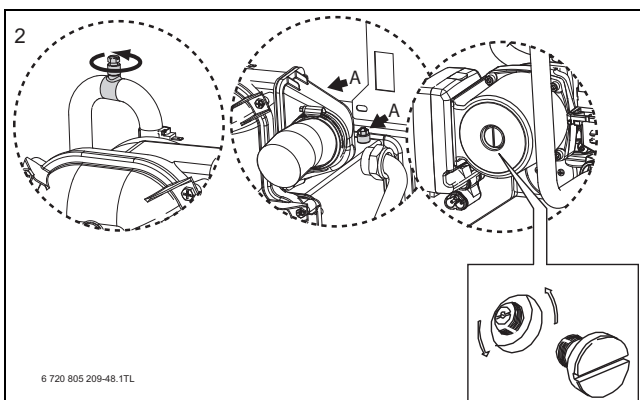

Fig. 62

3. Drain and thoroughly flush the system and boiler [C] to remove the flushing agent and debris.

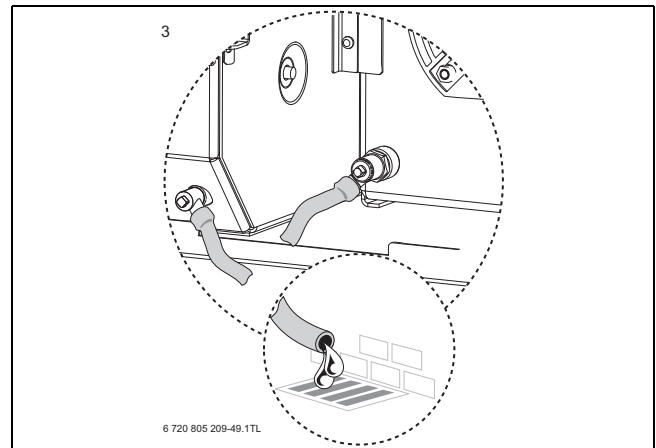

Fig. 63

Inhibitor (Central heating)

4. Check drain cocks and manual air vents are closed and all radiator valves are open.
5. Add a suitable inhibitor, (or combined inhibitor/anti-freeze if the system is exposed to freezing conditions) to the heating system in accordance with the manufacturer's instructions.
The inhibitor or combined inhibitor/anti-freeze must not cause damage to the materials within the boiler (mild steel, stainless steel, copper and brass) and any other materials/components within the system.
 - ▶ Fill the system to between 1 and 2 bar via a WRAS approved filling loop. Check the system pressure during venting and repressurise if necessary.
6. Vent the boiler, there are two vent points [A] at the top of the secondary heat exchanger, and one in the flow pipe. Always vent [A] and the vent screw [B] on the pump and all radiators; retighten vents when complete.

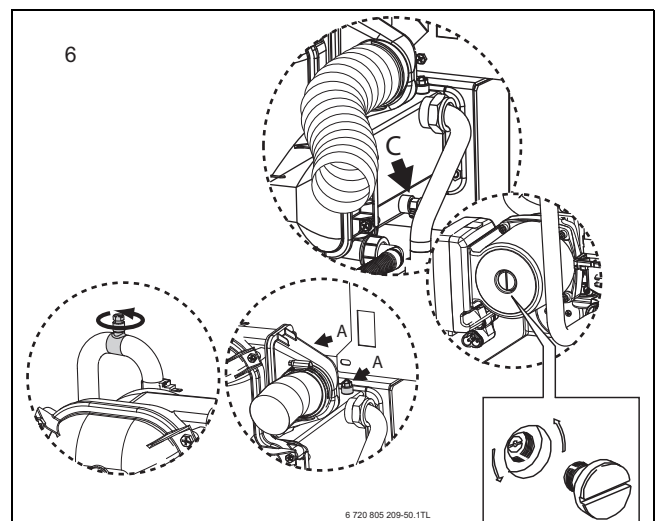

Fig. 64

7. Record the date when the inhibitor was added to the system on the guarantee card.



The concentration level of inhibitor in the system should be checked every 12 months or sooner if system content is lost.

The addition of sealing agents to the system water is not advised as this can cause problems with deposits left in the heat exchanger and invalidate the appliance and heat exchanger warranty.

6.5 Finishing commissioning - Appliance

1. Rotate the control box [A] towards you.
Slide back into position [B].
2. Refit the top panel [C] and press down to compress the seal when fitting the securing screws at each corner.
3. Push the front panel [D] up behind the top panel and push in at the base to secure with the screws [E] using the tool provided.

Always apply pressure at the edges of the boiler panels when securing to avoid accidental damage.

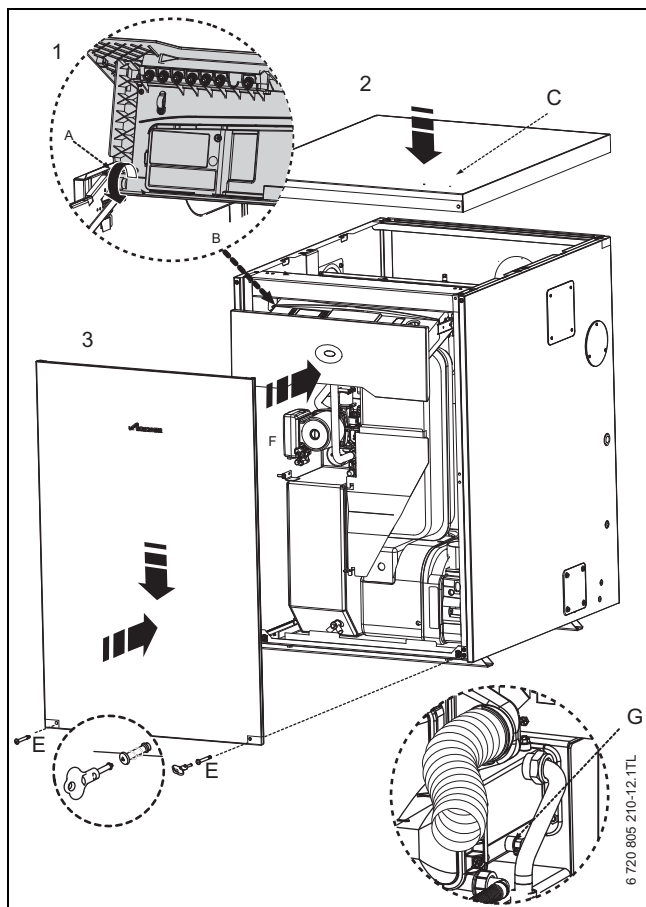

Fig. 65

Handover

- ▶ Complete the Guarantee Registration Card, Combustion Record (at the rear of this manual) and CD11 or an equivalent commissioning form.
- ▶ Set up the controls and show the user how to operate all the controls shown in the User Guide and all system controls.
- ▶ Where applicable, instruct the customer how to re-pressurise the system.
- ▶ If the appliance is unused and exposed to freezing conditions, shut off all the mains supplies and drain the system and boiler.



Release drain point [G] to drain the secondary heat exchanger.

7 Service and Spares

7.1 Inspection and service



CAUTION: Isolate the water, electricity and oil mains supplies before starting any work and observe all relevant safety precautions.



Do not use pressure washers or steam cleaners on this appliance or its cabinet.



WARNING: External equipment operated at 230 volts should not be serviced or repaired under adverse weather conditions

Routine servicing

To maintain efficient boiler operation, the following should be carried out at least once a year.

- ▶ Carry out a pre-service check and note any operational faults:

Pre-service checks

1. Undo the screws at the base of the front panel using the tool provided and pull the panel out and down to remove.
Store safely away from the working area.
Operate the appliance and system and note any faults which may need to be corrected during the service.
2. Pull the control box [A] all the way forwards.
 - Switch into service mode at switch [B].
3. Unplug burner lead [C] from control box lead [D].
 - An adapter lead is available to allow mains voltage service aids to be operated from the service connection (Service lead Part No. 8 716 113 483 0).
4. Swivel the expansion vessel [E] on its support bracket out of the boiler taking care not to snag any electrical cables or kink the flexible hose.
5. Loosen air duct pipe clip [F] and disconnect the air duct pipe.
6. Unscrew burner retaining nut [G] and remove the burner [L] and store safely away from the boiler.

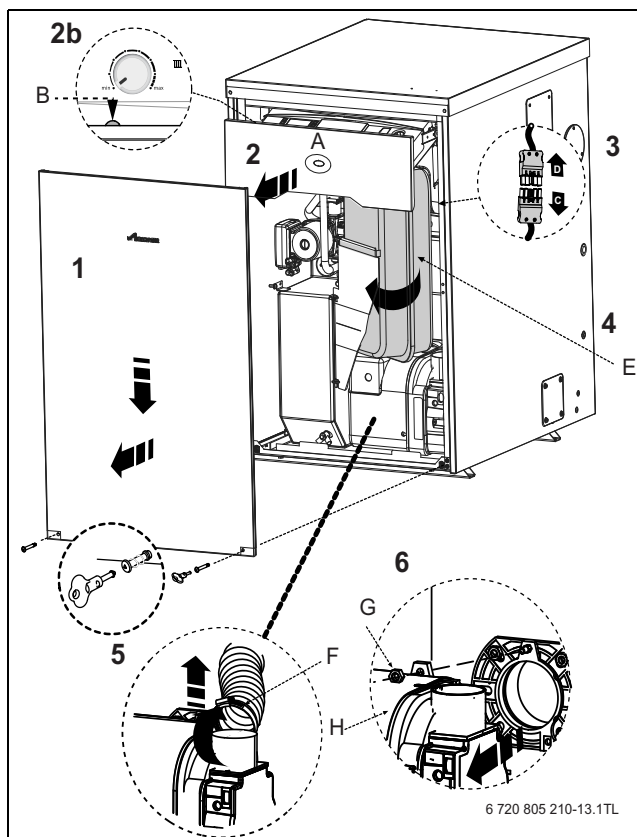

Fig. 66

See the following instructions for detail of some of the service requirements listed below:

- ▶ Check and clean the burner.
- ▶ Replace burner nozzle and flexible oil hose/s.

- ▶ Check and clean the baffle retainers.
- ▶ Check and clean the baffles.
- ▶ Check and clean the heat exchangers surfaces.
- ▶ Check the combustion chamber access door insulation board.
- ▶ Check that the flue system is unobstructed and clean as necessary.
- ▶ Clean or replace all oil filters.
- ▶ Check that the condensate system is not obstructed, clean and refill the condensate trap.
- ▶ **Sealed systems:** The PRV is a safety device and must be checked for correct operation.
The expansion vessel pressure must be checked and adjusted if necessary.

Clean the burner

- ▶ Loosen the 2 hex head screws and remove the air intake cover [A] and clear any debris from the air intake and air damper.
- ▶ Disassemble the burner to allow access to the fan impeller.
- ▶ Check the condition of the gaskets between these parts and replace if necessary.
- ▶ Note the position of the air damper adjustment and check the air damper moves freely.
- ▶ Clean both sides of the fan impeller and remove any debris from the burner housing.
- ▶ Check that the impeller rotates freely.
- ▶ Reassemble the components.
- ▶ Remove the combustion head [B] and thoroughly clean any deposits.



NOTICE:
Before removing or fitting a nozzle [C], loosen screw [D] and move the electrodes [E] forward.
After refitting check that the electrode gaps are correct, as shown in figure 67.

- ▶ Remove the nozzle [C].
- ▶ Check the nozzle holder is clear of any debris and clean if necessary.
- ▶ Fit a new oil atomising nozzle [C].

DO NOT dismantle the nozzle and DO NOT clean the nozzle tip.

- ▶ Check the electrodes [E] and reset if necessary as shown in figure 67.



The 12/18 model has a brass air deflection washer and locating circlip behind the nozzle. These must be in place for the correct operation of the burner.

- ▶ Refit the combustion head [B]. Check that the nozzle [C] is central in the combustion head [B] and the head settings are as shown. Ensure that the photocell is lined up with the sight hole.
- ▶ Withdraw the photocell [G] from its housing and wipe clean.
- ▶ Remove the oil pump internal filter, clean in Kerosene and reassemble.

The internal filter is accessed by removing screws [H] and the oil pump cover [J].

- ▶ Replace the standard flexible oil line/s at every annual service to prevent the possibility of leakage due to ageing.
- ▶ Reassemble the burner components.
- ▶ Check the O-ring seal located around the combustion head and replace if necessary. This seal must be in good condition, seal failure will cause flue gases to escape into the room.

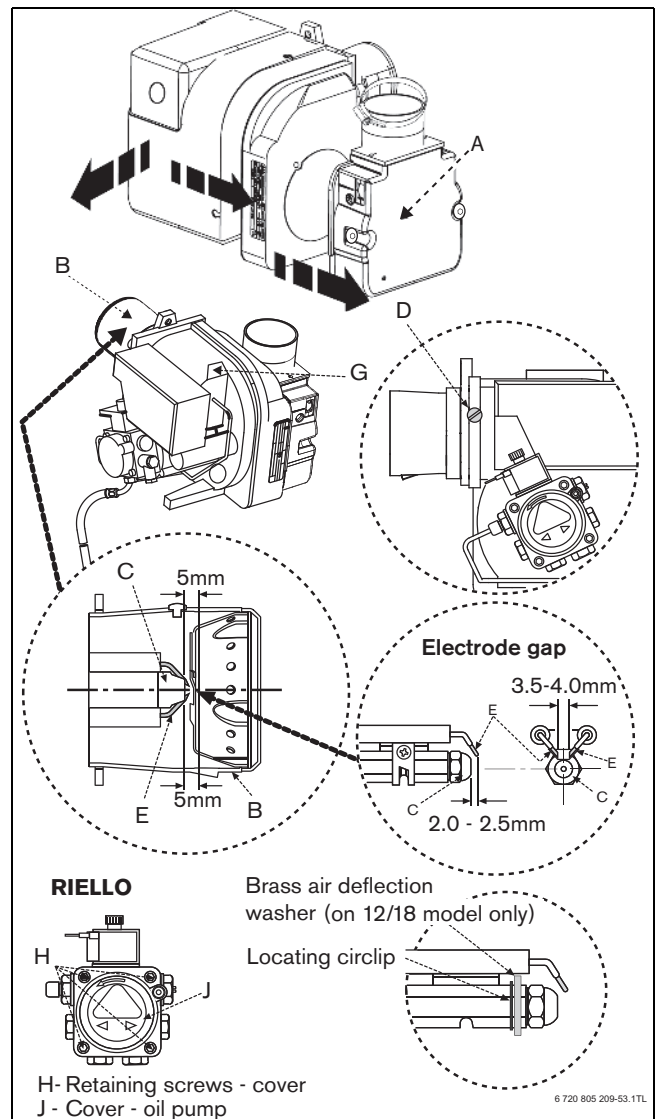

Fig. 67 Burner detail

External oil filter

- ▶ Remove the paper element from the external oil filter and replace it. If the filter contains a washable element, thoroughly clean in Kerosene and reassemble into the filter.

Clean the boiler

Manifold access

- ▶ Remove top cover by releasing the screws at each corner and lift free.
 1. Pull the control box [A] all the way forwards.
 - ▶ Depress the two levers [B], one on either side, to release the control box and pull fully forward and swivel control box upwards.
 2. Release screws [A] to remove the flue manifold access cover [B] and clear any debris.
 - ▶ Check the flue system and clean if necessary.
 - ▶ Remove the baffle retainer [C] and baffles [D] from the secondary heat exchanger.
 - ▶ Check and clean the secondary heat exchanger surfaces.



Do not use wire brushes and cleaning agents to clean the stainless steel secondary heat exchanger components.

- ▶ Check the condensate route [H] is clear.
- ▶ The condensate trap [F] should be removed and cleaned.
- ▶ Release the pipe locking tab [G] and disconnect the flexible pipe [H] from the top of the trap and move the flexible pipe up away from the trap.

- ▶ Release the trap locking tab [I] and move the trap up and back to remove from its mountings.
- ▶ Clean the trap by flushing with water.
- ▶ Check the O ring seals and replace if necessary, grease the seals with a solvent free grease.
- ▶ Refit the trap making sure that the locking tabs are locked in place.
- ▶ Pour 500 ml of water into drain [H] to refill the condensate trap and check that the condensate discharge pipe is discharging.
- ▶ Clean the secondary heat exchanger baffles [G] if necessary and refit correctly.
- ▶ Refit the baffle retainer [E].
- ▶ Check the seal on the manifold access cover [O] and replace if necessary.
- ▶ Refit the flue manifold access cover [D] and secure with screws [C].

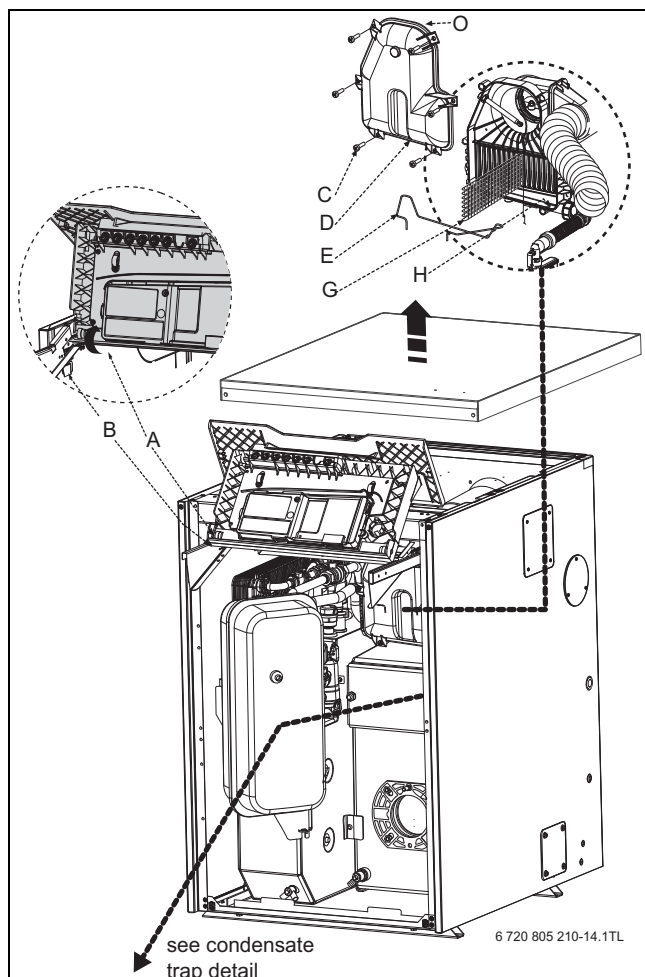

Fig. 68

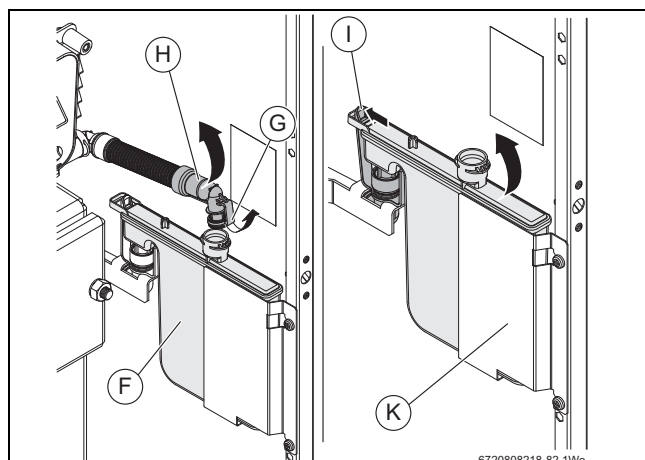

Fig. 69 Condensate trap detail

Combustion chamber

- ▶ Remove the retaining nuts and washers [A].
- ▶ Remove combustion chamber/baffle access door [B].
- ▶ Check the fibreglass rope seal on the combustion chamber/baffle access door [B] and replace if necessary.
- ▶ Remove the one piece baffle set [C], clean and check the condition of the baffles. Replace baffle set if considered to be badly corroded/degraded.
- ▶ Thoroughly clean all of the heat exchanger surfaces using a suitable brush and clear all loose debris from the combustion chamber.
- ▶ Check the condition of the combustion chamber/baffle access door insulation. If the insulation is damaged the door assembly must be replaced.
- ▶ Refit the one piece baffle set [C] making sure it is in the right location [D], correctly resting on the baffle rests [F] on either side of the combustion chamber and pushed securely into place.
- ▶ Refit combustion chamber door [B].

NOTICE:

Secure with nuts and washers [A] and tighten until the chamber door is firmly secured, do not over tighten the nuts.

Fire valve

- ▶ Check that the oil supply pipe has a fire valve fitted externally to the building with the fire valve sensor located within the appliance case. A fire valve sensor clip [E] is provided for this purpose.

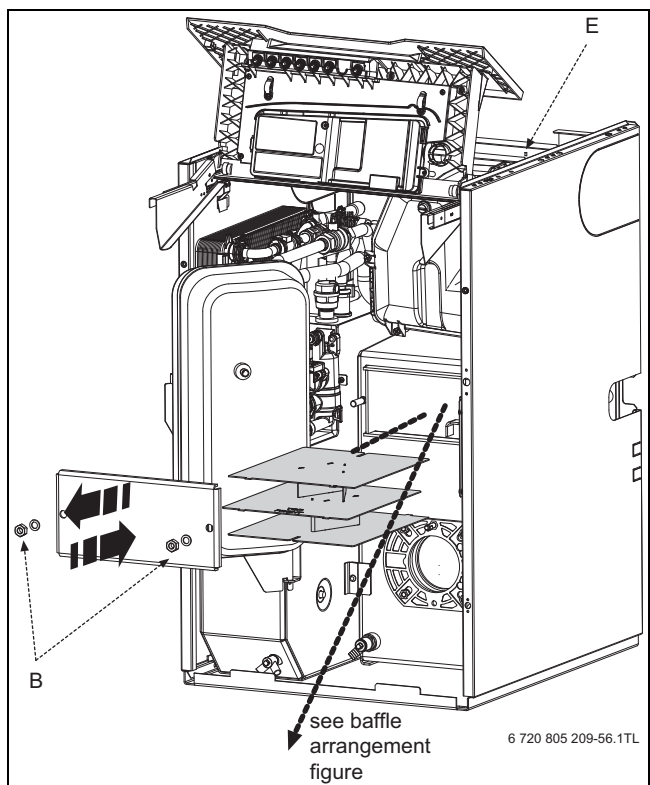

Fig. 70

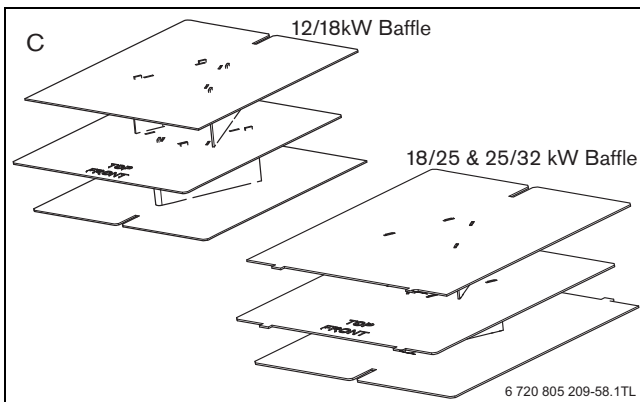

Fig. 71

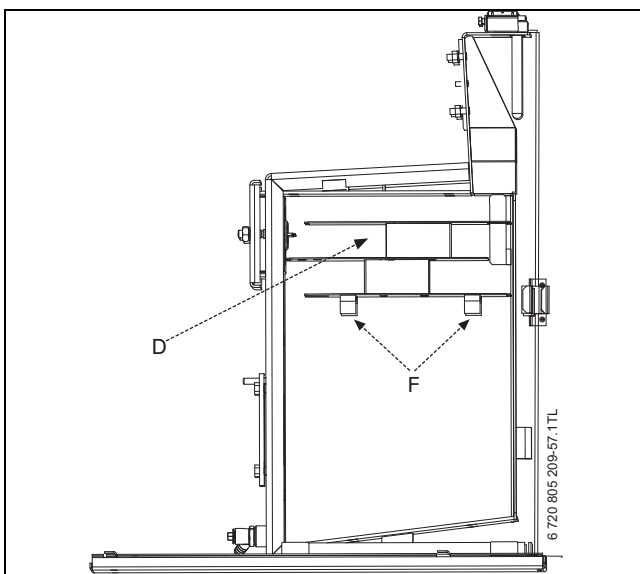
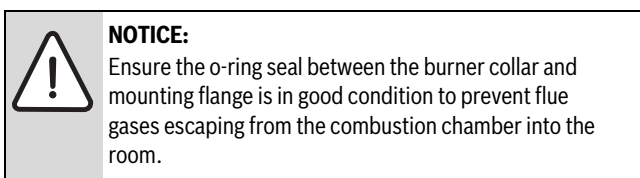

Fig. 72

Re-commission the burner

1. Align burner combustion head into the boiler collar.
 - ▶ Locate the burner retainer [A] over the threaded lug on the collar [B], push the burner firmly into the flange and secure in place with the retaining nut [C]. Tighten sufficiently but do not over tighten.
 - ▶ Check that the burner is seated correctly on its mounting flange and that the oil hose/s are routed correctly as shown on page 19.



2. Refit the flexible air duct and secure with clip [D].
3. Swivel the expansion vessel [F] back into position taking care not to kink the flexible hose or snag electric cables.
4. Plug burner lead [G] into connector [H].
 - ▶ Connect an oil pressure gauge to the oil pump, run the burner and check the oil pressure is correct for the required boiler output. Check that the smoke reading is between 0 and 1, if the smoke reading is above 1 check the air setting. If the air setting is correct check that the burner has been reassembled correctly. Allow the boiler to warm up then check the combustion settings are correct as indicated in table 9, adjust the CO₂ if necessary using the air shutter. When the combustion is correct turn off the boiler, remove the pressure gauge and refit the blanking plug and plastic cover.

Refit control box

5. Rotate the box towards you [J].
 - ▶ Slide control box drawer back into position.

Refit panels

6. Refit the top panel [K] and press down to compress the seal when fitting the securing screws at each corner.
7. Push the front panel [L] up behind the top panel and push in at the base to secure with the screws [M] using the tool provided.

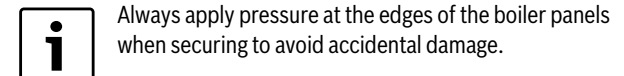

After service handover

- ▶ Make a note of the date of any water treatment.
- ▶ Set the controls back to the users requirements.
- ▶ Complete the service interval record at the back of this manual and a CD11 or an equivalent form.
- ▶ If the appliance is unused and exposed to freezing conditions; shut off all the mains supplies, isolate the boiler and drain the system and boiler, including the secondary heat exchanger.

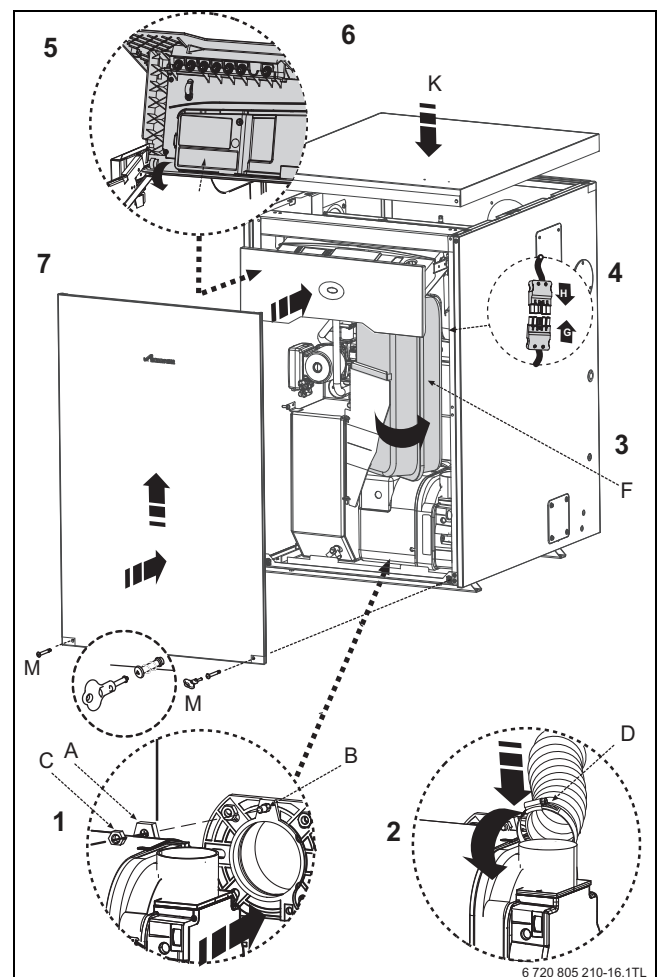

Fig. 73

Nominal boiler rating at normal operating temperature using Kerosene (Class C2)

Nozzle	Oil pump pressure		Fuel flow rate		Approximate flue gas temperature		Approximate air setting	Input (appliance) kW	Output (appliance) kW	Air damper disk setting	Burner head
	bar	psi	Kg/h	l/h	°C	%CO ₂					
Greenstar Heatslave II 12/18 model											
0.35 x 80° SR	9.0	132	1.04	1.32	72	11.0	3.0	12.4	12.0	12/15	LD2X Short
0.45 x 60° ES	7.5	110	1.28	1.63	77	11.5	5.0	15.4	15	12/15	LD2X Short
0.55 x 80° ES	7.8	115	1.54	1.96	80	12.0	5.0	18.5	18.0	18	LD2X Short
Greenstar Heatslave II 18/25 model											
0.50 x 80° ES	8.5	125	1.58	1.96	76	11.5	3.0	18.5	18.0	18	LD2SX Short
0.60 x 60° ES	8.5	125	1.84	2.33	81	12.0	3.5	22.1	21.5	21.5	LD2SX Short
0.75 x 80° ES	7.5	110	2.15	2.72	87	12.0	4.5	25.7	25.0	25	LD2SX Short
Greenstar Heatslave II 25/32 model											
0.75 x 80° ES	7.5	110	2.15	2.72	79	11.5	3.5	25.7	25.0	N/A	T2 Short
0.75 x 80° ES	10.0	147	2.46	3.12	81	12.0	4.5	29.4	28.5	N/A	T2 Short
0.85 x 80° EH	9.5	140	2.78	3.52	86	12.5	5.0	33.0	32.0	N/A	T2 Short

Table 9 Combustion settings

7.2 Short parts lists 12/18

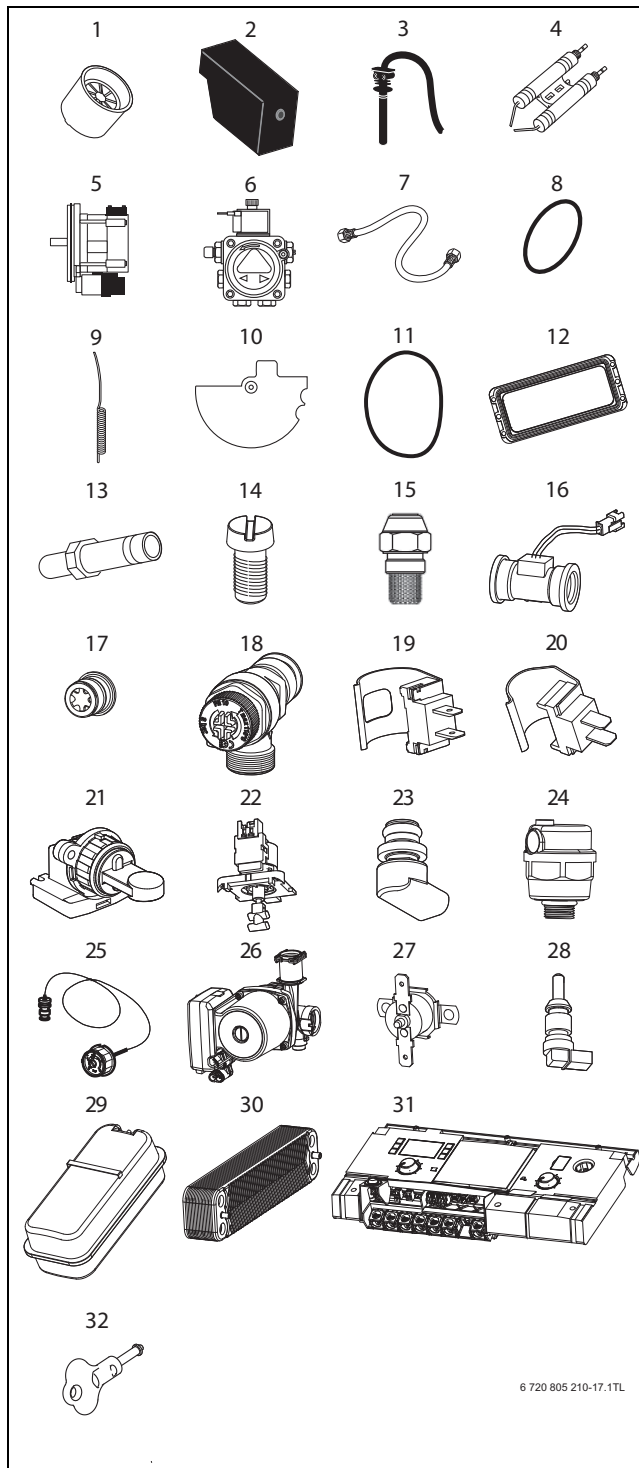
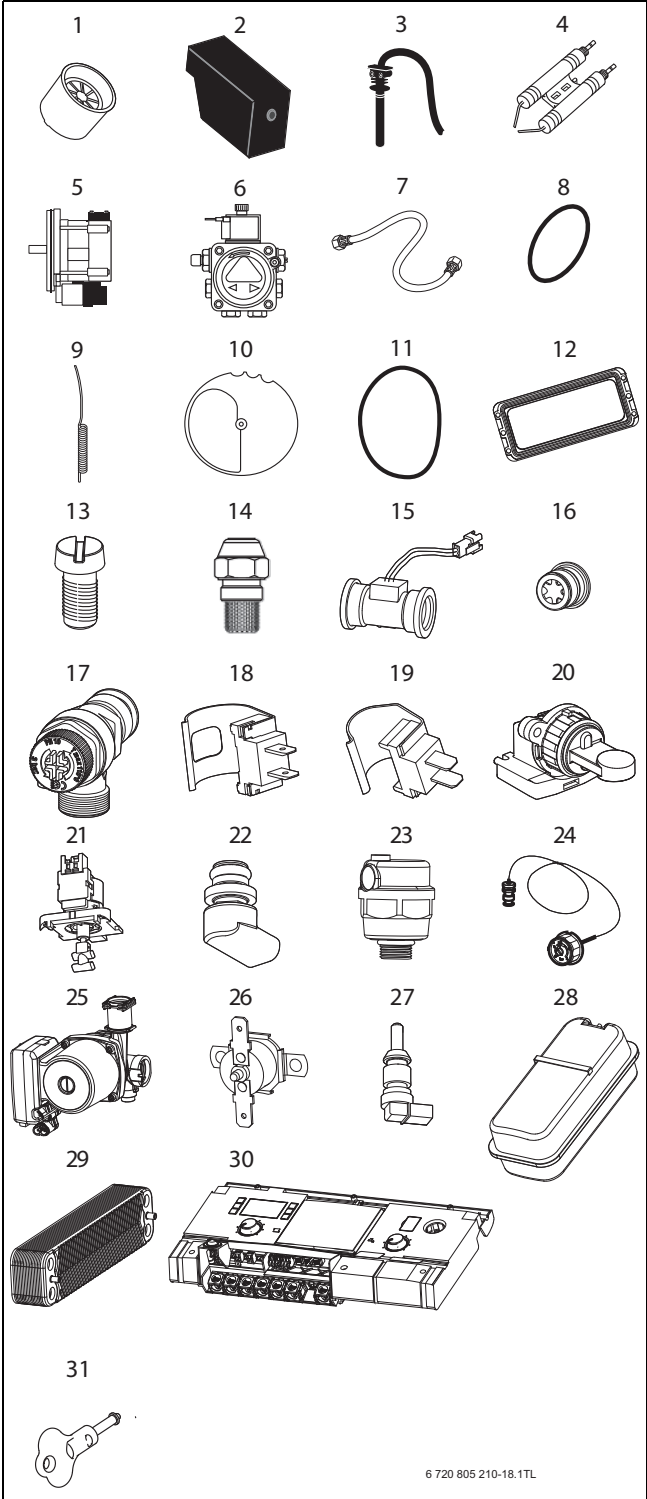

Fig. 74 Short parts list 12/18

No.	Description	Part No.
1	Combustion head - LD2X SH12/18	8 716 112 731 0
2	Control box MO535 MRF	8 718 682 250 0
3	Photocell	8 716 109 193 0
4	Ignition electrode	8 716 109 211 0
5	Motor	8 716 110 522 0
6	Oil pump - Riello RDB	8 718 689 342 0
7	Flexible oil hose kit	8 716 115 310 0
8	Burner 'O' ring	8 716 109 341 0
9	Manual reset flue thermostat	8 716 107 624 0
10	Air damper disc 12 15-18	8 718 690 377 0
11	Manifold access cover seal	8 716 107 536 0
12	Secondary Heat Exchanger gasket	8 718 690 792 0
13	Nozzle holder	8 716 116 638 0
14	Flue sample point screw	8 718 682 081 0
15	Oil nozzle	
	0.35 80°SR (12kW output)	8 716 156 679 0
	0.45 60°ES (15kW output)	8 716 114 545 0
	0.55 80°EH (18kW output)	8 716 156 671 0
16	Flow turbine	8 717 002 132 0
17	Flow regulator 15 litre (Lime)	8 708 500 407 0
18	Pressure relief valve	8 718 681 163 0
19	18mm Pipe NTC	8 718 688 801 0
20	15mm Pipe NTC	8 716 010 809 0
21	Diverter valve assembly	8 716 106 845 0
22	Diverter valve motor	8 718 682 839 0
23	DHW Pressure relief valve	8 717 401 029 0
24	Auto air vent	8 718 684 401 0
25	Pressure gauge	8 718 686 357 0
26	Pump assembly 12/18 & 18/25	8 716 117 574
27	Manual reset tank thermostat	8 718 690 548 0
28	Wet sensor	8 718 684 323 0
29	Expansion vessel	8 716 107 660 0
30	Plate heat exchanger	8 716 108 212 0
31	Control box	8 718 689 480 0
32	1/4 Turn cabinet key	8 716 114 013 0

Table 10

7.3 Short parts lists 18/25



No.	Description	Part number
1	Combustion head - LD2SX 18/25	8 718 682 170 0
2	Control box MO535 MRF	8 718 682 250 0
3	Photocell	8 716 109 193 0
4	Ignition electrode	8 716 109 211 0
5	Motor	8 716 110 522 0
6	Oil pump - Riello RDB	8 718 689 342 0
7	Flexible oil hose kit	8 716 115 310 0
8	Burner 'O' ring	8 716 109 341 0
9	Manual reset flue thermostat	8 716 107 624 0
10	Air damper disc 18 21.5-25	8 718 690 458 0
11	Manifold access cover seal	8 716 107 536 0
12	Secondary Heat Exchanger gasket	8 747 009 725 0
13	Flue sample point screw	8 718 682 081 0
14	Oil nozzle	
	0.50 80°ES (18kW output)	8 716 156 671 0
	0.60 60°ES (21.5kW output)	8 716 156 680 0
	0.75 80°ES (25kW output)	8 716 109 387 0
15	Flow turbine	8 717 002 132 0
16	Flow regulator 20 litre (Beige)	8 717 002 135 0
17	Pressure relief valve	8 718 681 163 0
18	18mm Pipe NTC	8 718 688 801 0
19	15mm Pipe NTC	8 716 010 809 0
20	Diverter valve assembly	8 716 106 845 0
21	Diverter valve motor	8 718 682 839 0
22	DHW Pressure relief valve	8 717 401 029 0
23	Auto air vent	8 718 684 401 0
24	Pressure gauge	8 718 686 357 0
25	Pump assembly 12/18 & 18/25	8 716 117 574
26	Manual reset tank thermostat	8 718 690 548 0
27	Wet sensor	8 718 684 323 0
28	Expansion vessel	8 716 107 660 0
29	Plate heat exchanger	8 716 108 212 0
30	Control box	8 718 689 480 0
31	1/4 Turn cabinet key	8 716 114 013 0

Table 11 Short parts list 18/25

Fig. 75 Short parts list 18/25

7.4 Short parts lists 25/32

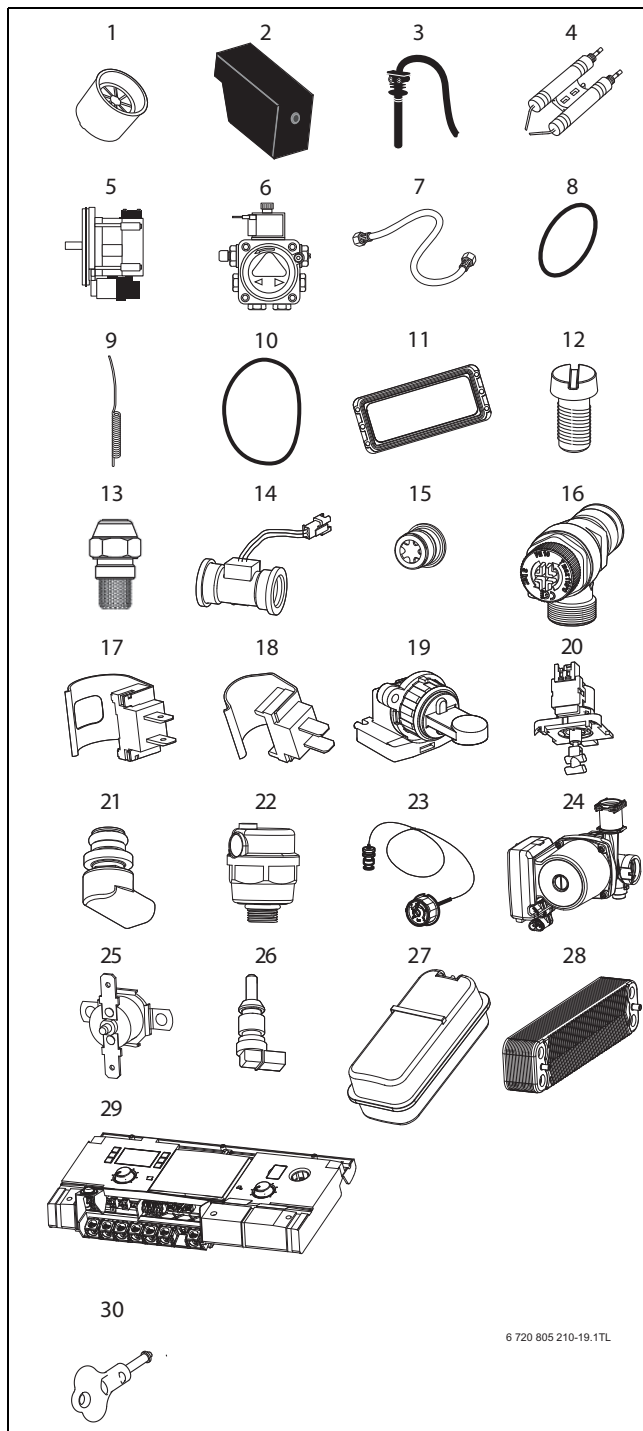

No.	Description	Part number
1	Combustion head - T2 SH 25/32	8 716 112 780 0
2	Control box MO535 MRF	8 718 682 250 0
3	Photocell	8 716 109 193 0
4	Ignition electrode	8 716 109 211 0
5	Motor	8 716 110 522 0
6	Oil pump - Riello RDB	8 718 689 342 0
7	Flexible oil hose kit	8 716 115 310 0
8	Burner 'O' ring	8 716 109 341 0
9	Manual reset flue thermostat	8 716 107 624 0
10	Manifold access cover seal	8 718 682 849 0
11	Secondary Heat Exchanger gasket	8 718 688 799 0
12	Flue sample point screw	8 718 682 081 0
13	Oil nozzle	
	0.75 80°ES (25 & 28.5kW output)	8 716 109 387 0
	0.85 80°EH (32kW output)	8 716 156 644 0
14	Flow turbine	8 717 002 132 0
15	Flow regulator 25 litre (Grey)	8 718 681 198 0
16	Pressure relief valve	8 718 681 163 0
17	18mm Pipe NTC	8 718 688 801 0
18	15mm Pipe NTC	8 716 010 809 0
19	Diverter valve assembly	8 716 106 845 0
20	Diverter valve motor	8 718 682 839 0
21	DHW Pressure relief valve	8 717 401 029 0
22	Auto air vent	8 718 684 401 0
23	Pressure gauge	8 718 686 357 0
24	Pump assembly 25/32	8 716 117 628
25	Manual reset tank thermostat	8 718 690 548 0
26	Wet sensor	8 718 684 323 0
27	Expansion vessel	8 716 107 660 0
28	Plate heat exchanger	8 716 108 212 0
29	Control box	8 718 689 480 0
30	1/4 Turn cabinet key	8 716 114 013 0

Table 12 Short parts 25/32

Fig. 76 Short parts list 25/32

8 Fault finding and diagnosis

8.1 Status cause codes

These cause codes are displayed during the normal operation of the boiler. They are not faults, they just give information on the current status of the boiler in real time.

Cause code

During normal operation various status codes can be displayed by pressing the service button.

The first screen of the information menu displays the current status code, this will change as the boiler runs through the various modes and sequences.

Cause code		
200	CH active	The Central Heating system is being heated.
201	DHW active	The Domestic Hot Water is being heated/tank is being heated.
202	CH Anti rapid-cycle mode	Time delay to prevent rapid-cycling of the boiler on the room thermostat.
203	System stand-by	The boiler has no CH or DHW demands.
270	Power up mode	The boiler is ON, warming up and running self check routines. This lasts approximately 35 seconds.
358	Three way valve anti-seize	Anti-seize operation. If the diverter valve has not moved in 24 hours, the valve is operated to prevent seizing, duration approximately 10 seconds.

Table 13

8.2 Information menu





Selecting the Information Menu

The Information Menu is a “read only” menu. Information about the boiler is displayed here, some of the values are updated in real time to give the current status of the boiler.

All menus time-out after 2 minutes and the display returns to the normal operation display, the display backlight turns off after another 30 seconds and goes into stand-by mode.

Double up or down arrows indicate that the menu can only be scrolled up or down, an up arrow combination indicates position in the menu where options can be scrolled either up or down.

To enter the Information Menu

- Press the  button to enter the Information Menu.
 - A 3 figure boiler status code will be displayed alongside the Information Menu number. Refer to page 28 for a description of the boiler status codes.
- Use the  and  arrow buttons to scroll through the menu items.
- Press the  button again to exit the Information Menu.

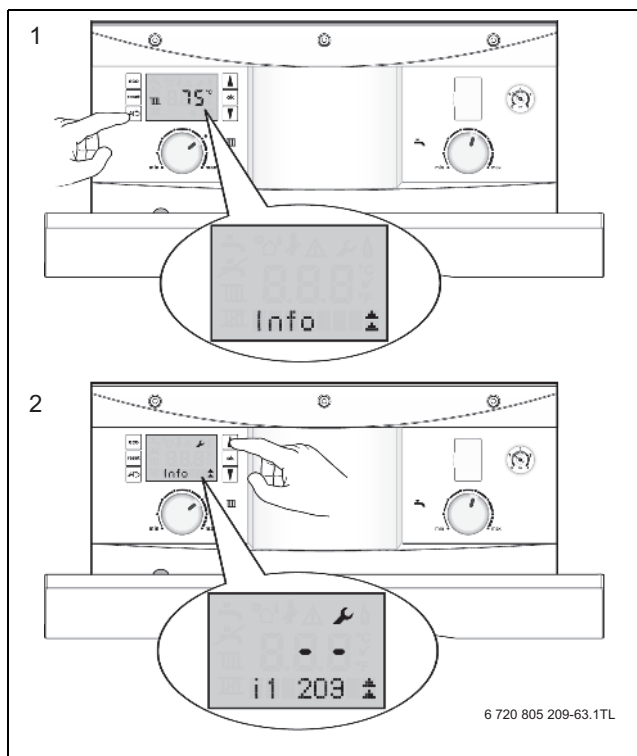

Fig. 77

Information Menu listing

i1	Current status	Every operation and mode of the boiler has a related boiler status code. The boiler status code is displayed on the screen as a 3 figure number. Refer to page 28 or error table for information on the boiler status code.
i2	Last error	This can be viewed during normal operation. Displays the last diagnostic code with boiler status code.
i3	Maximum CH output	The maximum possible CH output is displayed in kW.
i4	Maximum DHW output	The maximum possible DHW output is displayed in kW.
i6	DHW flow rate	The screen displays the current DHW flow rate in 0.1 l/m units.
i7	CH flow temperature set point	This is the temperature set point for the primary flow from the main heat exchanger. This will be zero during CH demand.
i9	Flow temperature	This is the actual temperature from the main heat exchanger displayed in real time (rounded to 0.5°C units).
i10	Maximal temperature	This is the current temperature from the “maximal safety sensor” displayed in real time (rounded to 0.5°C units). The sensor is mounted on the top of the primary heat exchanger.
i11	DHW flow temperature	Current DHW flow temperature displayed in real time (rounded to 0.5°C units).
i12	DHW temperature set point	This is the thermal store temperature set point, selected via the Hot Water control knob on the fascia, (rounded to 0.5°C units).



Table 14

i13	Thermal store current temperature	This is the thermal store current temperature, displayed in real time (rounded to 0.5°C units).
i14	DCW inlet temperature	Current DCW inlet temperature displayed in real time (rounded to 0.5°C units).
i15	Out door temperature	This is the out door temperature displayed in real time (rounded to 0.5°C units). Only available if a Weather Compensation sensor has been fitted and Weather Compensation is active.
i19	Time inputs	This indicates the status of the optional fascia mounted controls: 0 = CH off, DHW off 1 = CH off, DHW on 2 = CH on, DHW off 3 = CH on, DHW on
i20	Software version	CBS software version of main PCB.
i21	Software version	HIS software version of the HIS PCB.
i22	HCM number	HCM last 3 digits displayed: 391 = 12/18 kW 390 = 18/25 kW 301 = 25/32 kW
i23	HCM version number	For example "4"

Table 14

8.3 Service menus

Selecting Service Menus

- Press and hold the  and  buttons together for 1 second, the display will show Menu 1.
 - Double up or down arrows indicate that the menu can only be scrolled up or down, an up and down arrow combination indicates positions in the menu where options can be scrolled either up or down.

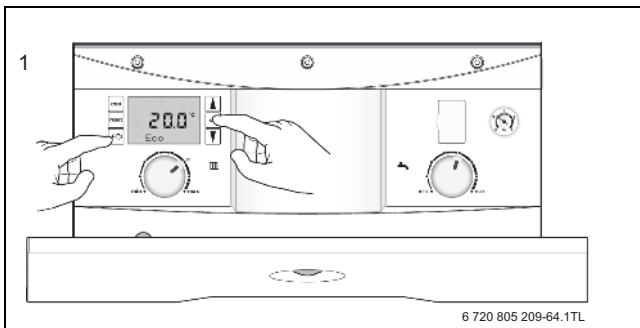



Fig. 78

- Scroll up and down through the menus with the  and  arrow buttons on the right hand side of the display.

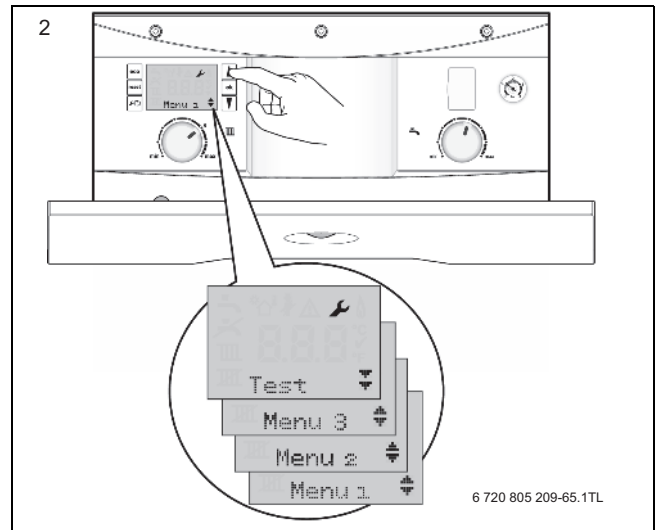



Fig. 79

Menu 1 system parameters

Initially Menu 1 will be displayed.

1.W1	Weather Compensation Functionality	Enable.
1.W2	Weather Compensation Functionality	Point A (@-10°C)
1.W3	Weather Compensation Functionality	Point B(@+20°C)
1.W4	Weather Compensation Functionality	System frost protection enable.

Menu 2 boiler parameters

- Select Menu 2 via the   arrow buttons.

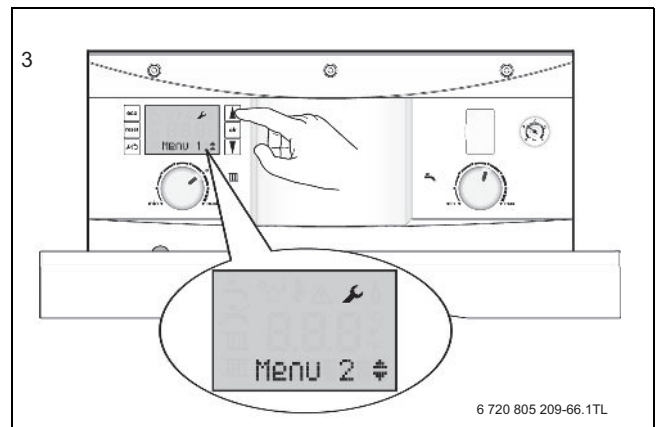







Fig. 80

- Press and hold the  button for 1 second to enter Menu 2.
 - The menu lists the boiler parameters, that can be adjusted in this menu.
 - To modify the setting, select the desired menu option and press the  button, the option will flash.
 - Adjust the parameter using the   arrow buttons and press the  button to confirm.
 - A  will display for 3 seconds to confirm the update of the new value.

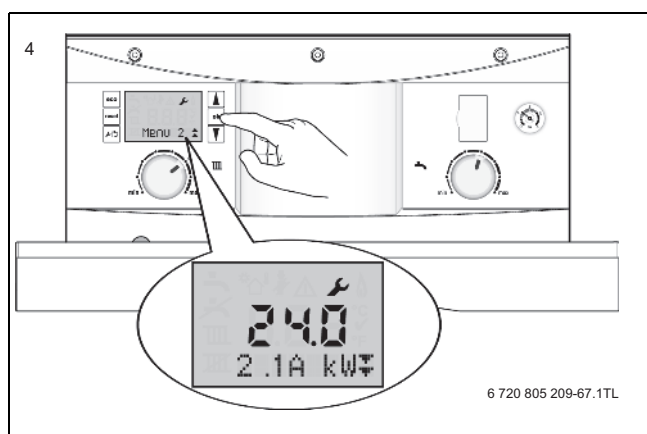

Fig. 81

2.7A	Demand/fault LED (blue light) activation	0 = The blue light will only operate as a flashing fault alert.
		1 = The blue light will operate as a boiler operation and fault alert. This is set to 1 by default.

i Menus 3 and Test are empty and are not used on this appliance.

8.4 Factory reset and fault codes

8.4.1 Factory reset

To reset changes made in Menu 2 back to the factory default setting:

i Any changes made to Menu 1 are not reset by these actions.

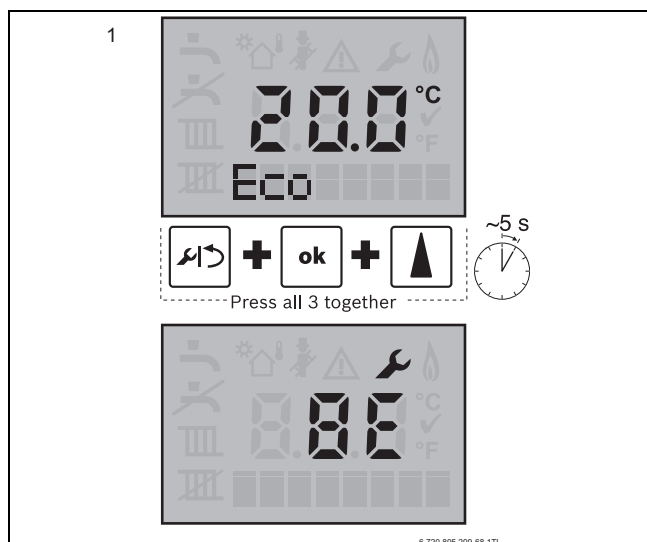

Fig. 82

1. Press and hold the and buttons for at least 5 seconds. The screen will then display code BE with the spanner symbol.

2. Press the button and "reset" will be displayed with the tick symbol for 3 seconds. After 3 seconds the display will revert to the normal operation screen.

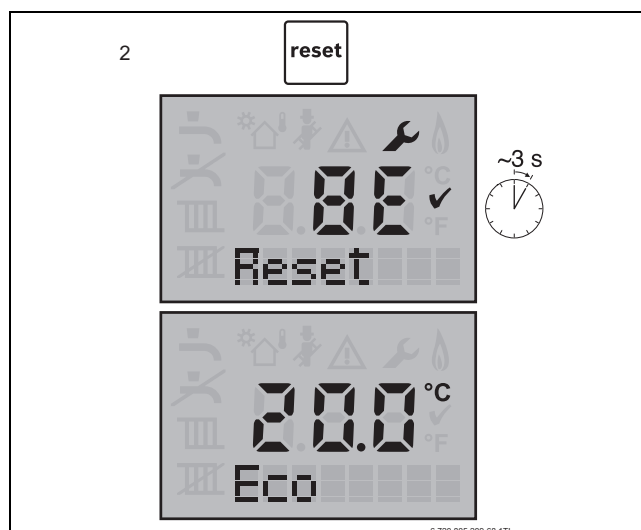

Fig. 83

8.4.2 Locking or Blocking fault conditions

Should a fault develop with this boiler (or the system), the boiler will enter into a Locking or Blocking condition.

Locking condition

- The boiler display will flash a warning triangle.
- A 3 digit **cause code** will flash on the display during a Locking error.
- An alpha numeric **fault code** will be displayed indicating the fault group.

Manual intervention is required following clearance of the fault.

- ▶ Press the reset button on the boiler fascia.

Blocking condition

- The boiler will stop operating and no fault code will be displayed.
- An alpha numeric **fault code** is accessed in the info menu by pressing the spanner/return button.

i Unlike a Locking error, during a Blocking error (or normal operating status), a fault code is not automatically displayed.

- A 3 digit cause code is also accessed in the info menu by pressing the spanner/return button.
- The condition will clear automatically when the associated fault clears e.g. waiting for an area of the boiler to cool down.
- In some cases a Blocking error has a defined time duration prior to changing to a Locking condition.

8.4.3 Cause and fault codes

Cause code	Fault code	Description	Reset type	Blocking	Locking	Possible cause
210	E9	Max temperature thermostat activated	Reset		X	Flue gas or tank thermostat overheat. Reset the overheat thermostat before resetting the appliance.
212	No code	Safety or flow temperature rises too high		X		Air lock or reduced water content.
218	E5	Flow temperature too high	Reset		X	Primary sensor overheated.
219	E9	Safety temperature too high	Reset		X	The main heat exchanger has overheated. Maximum temperature 105°C.
220	E9	Safety sensor short circuit	Reset		X	Maximum temperature sensor on the main heat exchanger has failed.
221	E9	Safety sensor open circuit	Reset		X	Maximum temperature sensor on the main heat exchanger has not been recognised.
222	E2	Flow sensor short circuit	Reset		X	Flow sensor shorted or damaged.
223	E2	Flow sensor open circuit	Reset		X	Flow sensor disconnected or damaged.
233	E2	HCM (Heat Control Module)	Reset		X	HCM Code plug missing or defective.
237	F0		Reset		X	Resistors between plug X4 pins 3 & 5 disconnected/>150k Ω or water in the burner control box
238	F0		Reset		X	Resistors between plug X4 pins 3 & 5 disconnected/>150k Ω or water in the burner control box
239	F0	Watchdog error	Reset		X	
259	F0	AD reference error	Reset		X	
263	F0	Appliance powered off with locking fault present	Reset		X	Locking fault present when powered off.
271	D4	Temperature difference between flow and safety sensors exceeds limit		X		The temperature of the primary flow and the safety sensor on the main heat exchanger should be within 15°C of each other.
276	E9	Flow temperature exceeds 95°C		X		Primary overheat - boiler waits for temperature to reduce, approximately 30 minutes.
277	E9	Safety temperature exceeds 95°C		X		Main heat exchanger safety sensor overheat - boiler waits for temperature to reduce, approximately 30 minutes.
278	F0	Sensor test error	Reset		X	On power up, all safety sensors are checked. Check has failed.
279	F0	AD converter error	Reset		X	
290	F0	AD converter reference error	Reset		X	
332	E5	Primary flow has exceeded 105°C	Reset		X	Primary sensor overheated.
359	No Code	DHW outlet or storage tank exceeds 90°C		X		Pump & burner are blocked until temperature drops to <89°C.
360	9A	Incorrect HCM for boiler variant		X		
380	No code	Inlet DCW temperature higher than DHW outlet temperature		X		The output is blocked until the inlet temperature drops below the output temperature.
808	A7	DHW sensor defective	Reset		X	
809	A0	Thermal store sensor defective	Reset		X	
855	9F	Burner lock out	Reset		X	Check the burner and fuel supply. Ensure the oil supply is free of contaminants.
856	9F	5 burner lockouts repeated resets	Turn boiler off/on		X	After Five 855 burner lock outs in one demand period, cause code 856 is displayed. After boiler off/on cause code 263 will be displayed, press the reset button to clear this fault. another 5 burner lock resets can be attempted.

Table 15 Cause and fault codes

H code	Displayed symbols	Cause
H03	Warning triangle and House symbol displayed on controller	Weather compensation activated but no weather sensor detected, refer to section 5.11 on page 24 for more information.
H11	Warning triangle symbol displayed on controller	DCW in sensor defect, (appliance operation not affected)

Table 16 H fault codes

8.5 DHW function chart

6 720 805 209-70,1TL

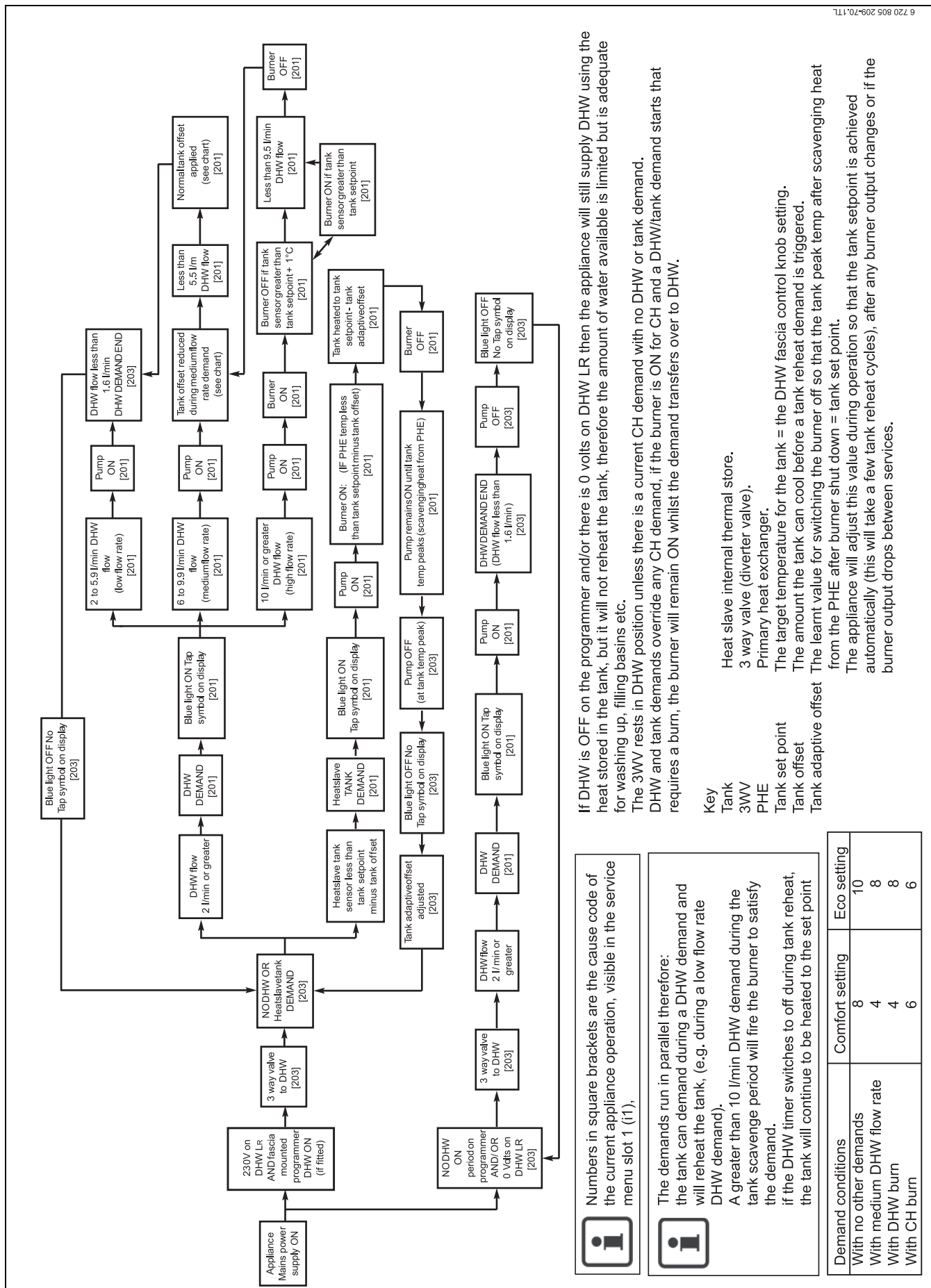

i Numbers in square brackets are the cause code of the current appliance operation, visible in the service menu slot 1 (i1).

i The demands run in parallel therefore: the tank can demand during a DHW demand and will reheat the tank, (e.g. during a low flow rate DHW demand).
A greater than 10 l/min DHW demand during the tank scavenge period will fire the burner to satisfy the demand.
if the DHW timer switches to off during tank reheat, the tank will continue to be heated to the set point

Demand conditions	Comfort setting	Eco setting
With no other demands	8	10
With medium DHW flow rate	4	8
With DHW burn	4	8
With CH burn	6	6

If DHW is OFF on the programmer and/or there is 0 volts on DHW LR then the appliance will still supply DHW using the heat stored in the tank, but it will not reheat the tank, therefore the amount of water available is limited but is adequate for washing up, filling basins etc.
The 3WV rests in DHW position unless there is a current CH demand with no DHW or tank demand.
DHW and tank demands override any CH demand, if the burner is ON for CH and a DHW/tank demand starts that requires a burn, the burner will remain ON whilst the demand transfers over to DHW.

- Key
- Tank
 - 3WV
 - PHE
 - Tank set point
 - Tank offset
 - Tank adaptive offset

- Heat slave internal thermal store.
- 3 way valve (diverter valve).
- Primary heat exchanger.
- The target temperature for the tank = the DHW fascia control knob setting.
- The amount the tank can cool before a tank reheat demand is triggered.
- The learnt value for switching the burner off so that the tank peak temp after scavenging heat from the PHE after burner shut down = tank set point.
- The appliance will adjust this value during operation so that the tank setpoint is achieved automatically (this will take a few tank reheat cycles), after any burner output changes or if the burner output drops between services.

Fig. 84

8.6 CH function chart

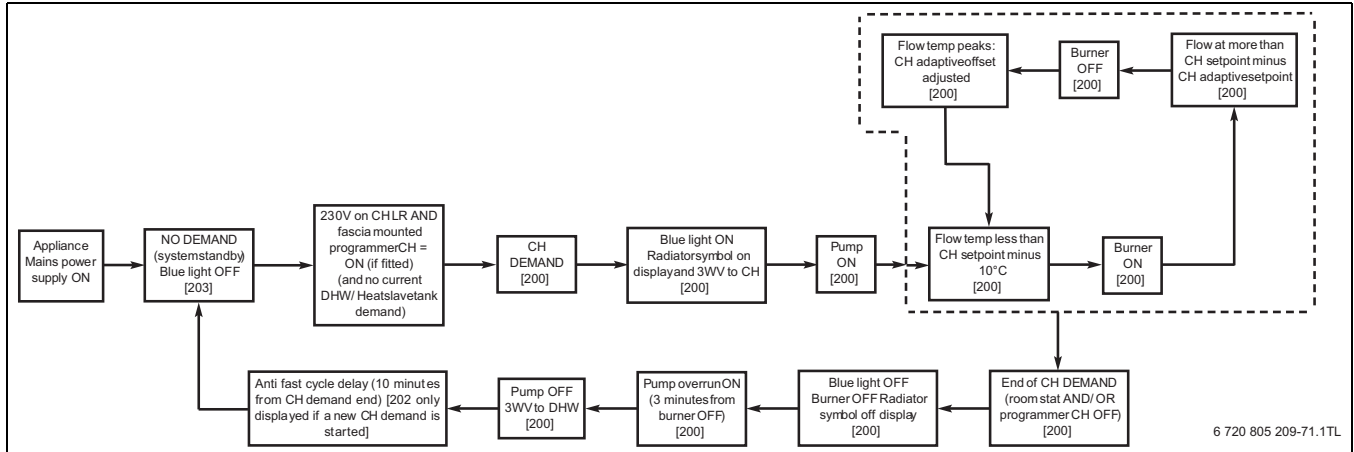

Fig. 85



Numbers in square brackets are the cause code of the current appliance operation, visible in the service menu slot 1 (i1),

Key	
3WV	3 way valve (diverter valve).
CH set point	The target flow temperature set on the CH fascia control knob.
CH adaptive offset	The learnt offset temperature applied to the CH flow so that the peak flow temperature after burner OFF = CH set point.
Anti fast cycle delay	To stop the appliance short cycling if a room stat is intermittently calling or is poorly positioned, there is a 10 minute delay for CH demands timed from the last CH demand end.

8.7 Protection functions

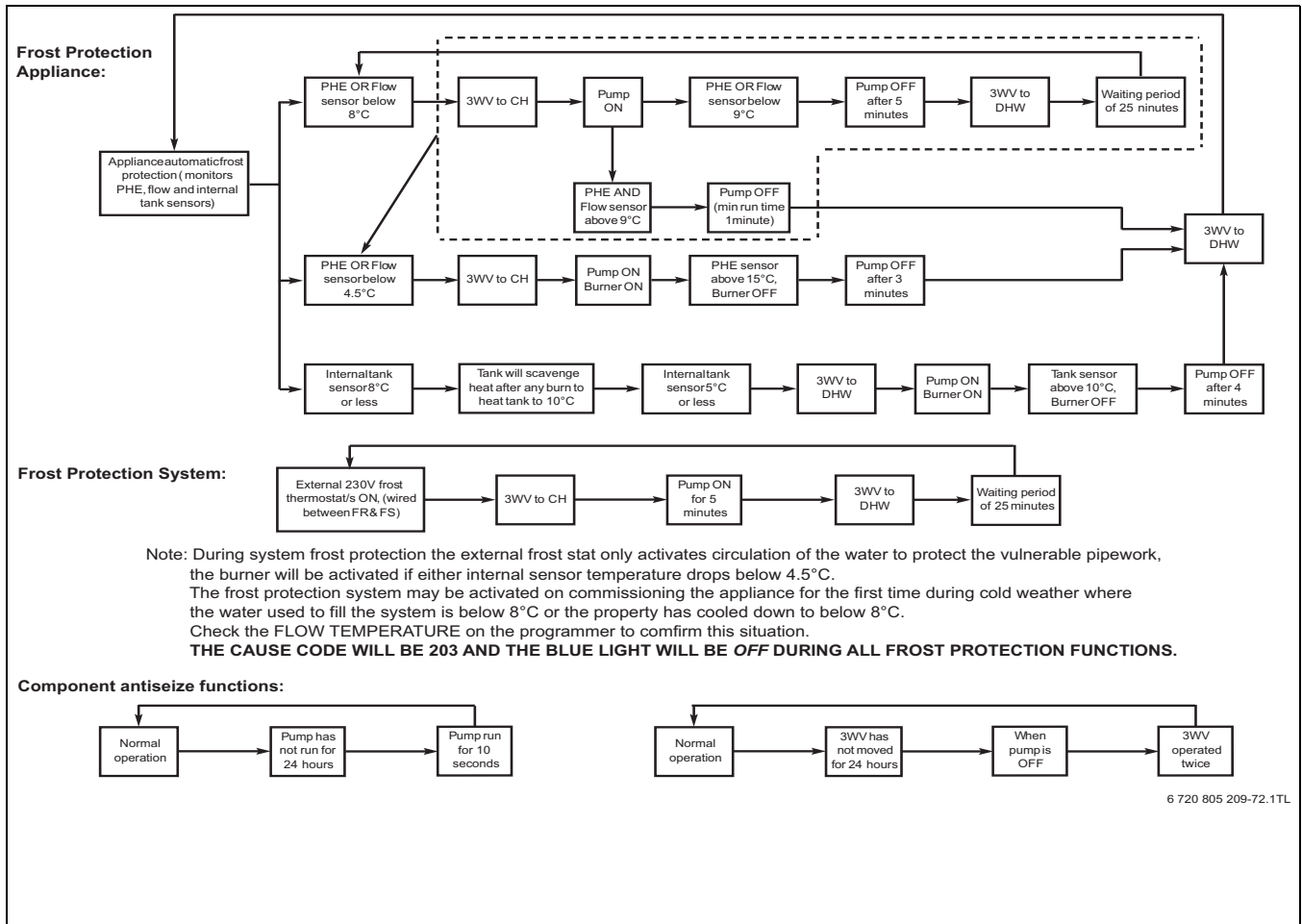

Note: During system frost protection the external frost stat only activates circulation of the water to protect the vulnerable pipework, the burner will be activated if either internal sensor temperature drops below 4.5°C. The frost protection system may be activated on commissioning the appliance for the first time during cold weather where the water used to fill the system is below 8°C or the property has cooled down to below 8°C. Check the FLOW TEMPERATURE on the programmer to confirm this situation. **THE CAUSE CODE WILL BE 203 AND THE BLUE LIGHT WILL BE OFF DURING ALL FROST PROTECTION FUNCTIONS.**

Fig. 86

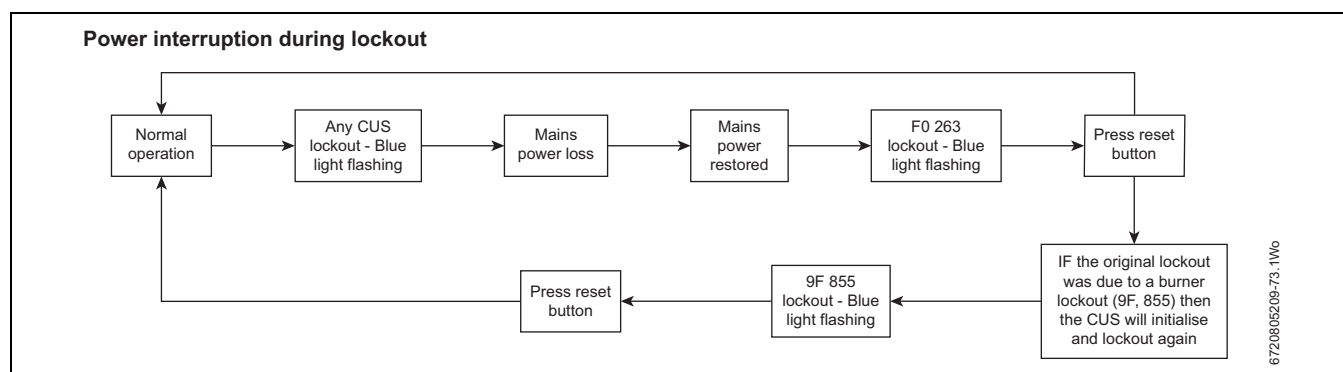

Fig. 87

Key	
PHE	Primary heat exchanger.
3WV	3 way valve (diverter valve).
FS	Appliance connection frost stat supply (230 V)
FR	Appliance connection frost stat return (230 V)

8.8 Solar compatibility

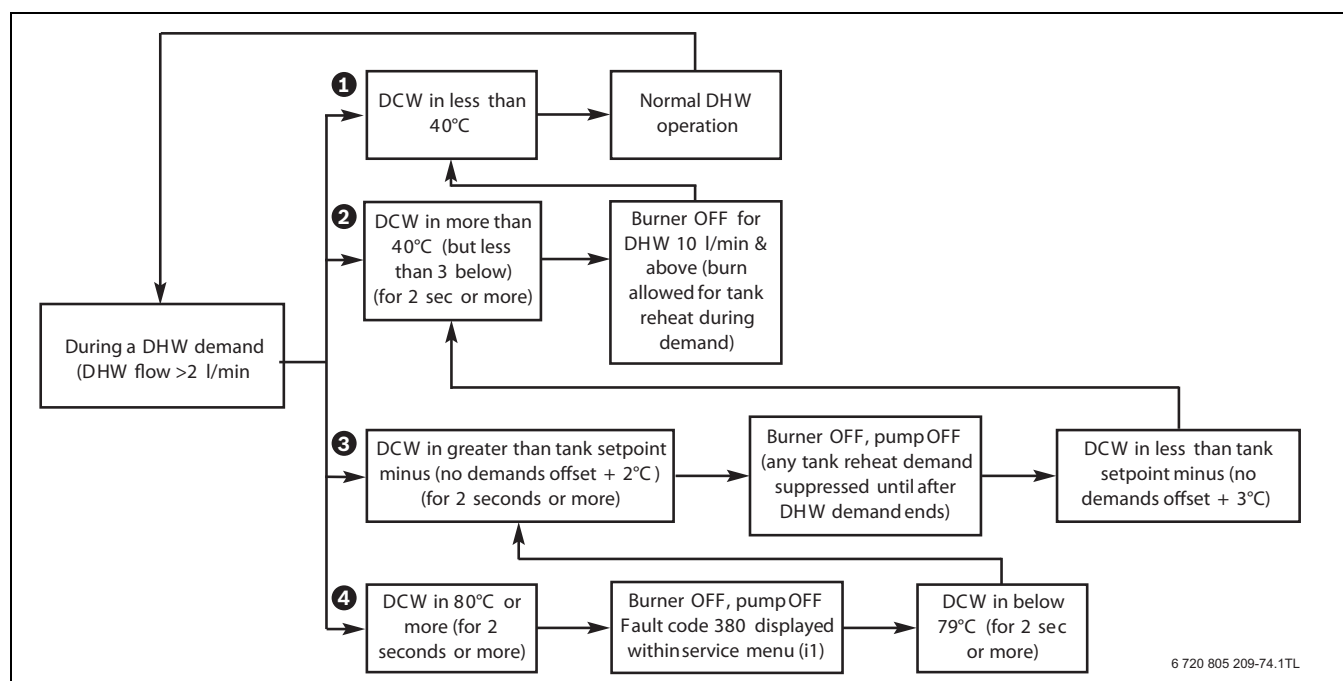

Fig. 88

- [1] Normal operation: the tank will cool more slowly for the same DHW performance if the DCW is above normal DCW temperature, thus saving fuel.
- [2] Solar tank hot: therefore the burner will not be required at high DHW flow rate and the tank will boost the solar heated water if the temperature drops.
- [3] Solar tank will satisfy the DHW requirements: therefore the appliance allows the water to pass straight through without taking any action apart from monitoring the temperatures. To utilise the solar panels to their maximum potential, the solar tank thermostat will need to be set high and the Heatslave II DHW setting low.
- [4] Solar tank overheat: DCW above solar tank limit, appliance will not operate pump or burner and fault code will be displayed within the service menu.

8.9 Burner diagnostics mode

Service/installation engineers only.

To access the Burner control box diagnostics or to use the burner reset button to reset the burner, the burner diagnostic mode must be activated as follows:

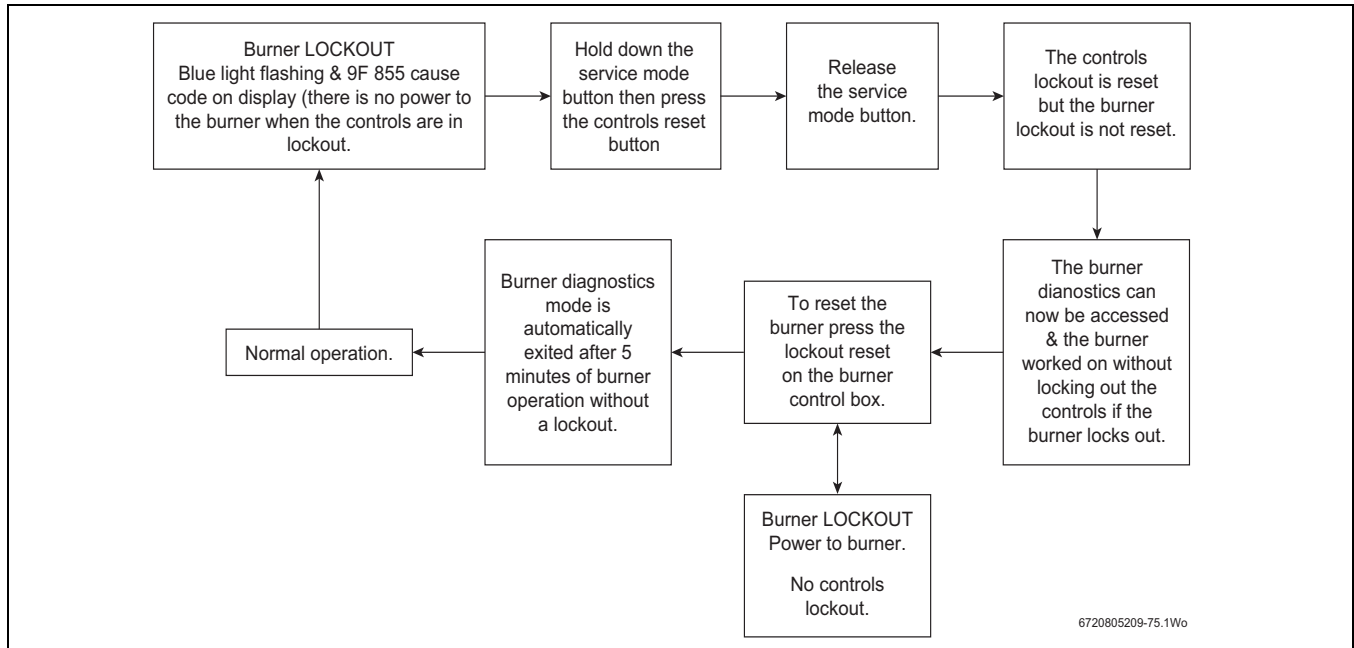

Fig. 89



The burner diagnostics mode can be manually exited at any time when the burner is locked out by holding down the service mode button whilst pressing the controls reset button.

Fault code 9F 856: If burner lockout is reset 5 times in one demand period using the fascia reset button the controls will lockout with a new code: 9F 856. This is to protect the burner components against over use of the reset and requires a power down of the appliance to reset. The burner control box also has this facility, if the reset button is operated 5 times the control box will not reset until the power has been interrupted to the burner.

8.10 Riello digital control boxes

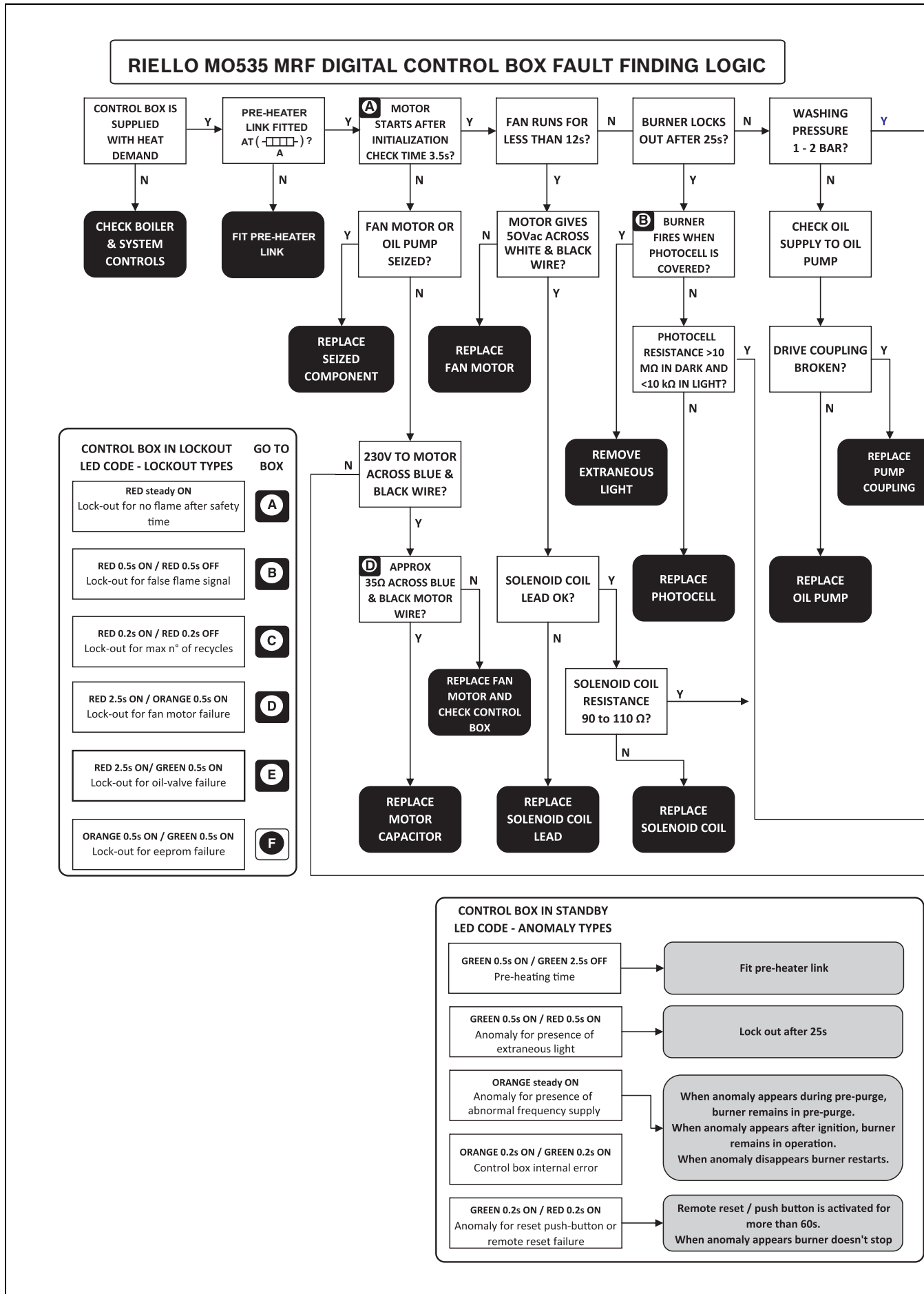

Fig. 90

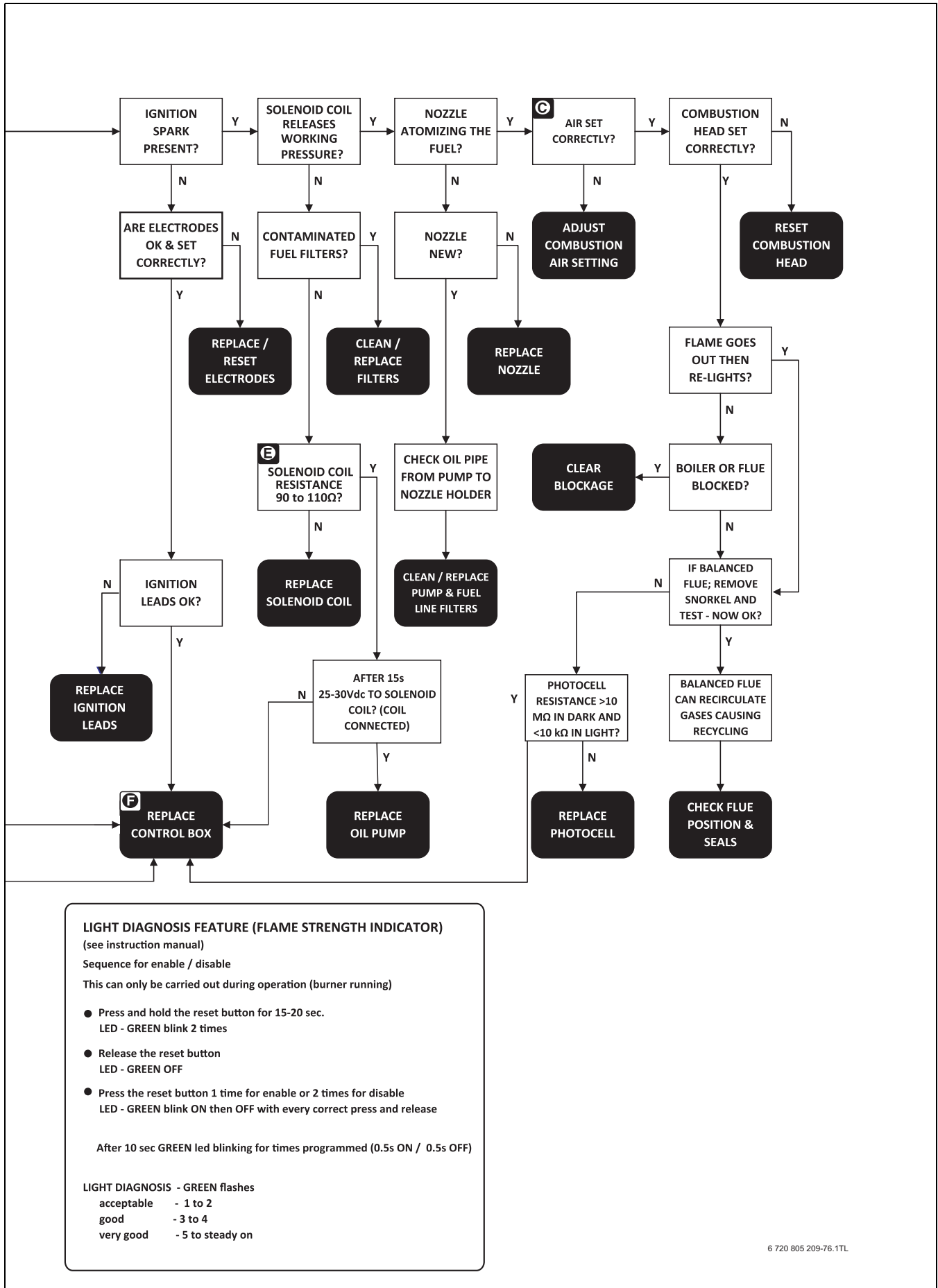

Fig. 91

8.11 Oil supply vacuum testing

A vacuum gauge can be attached to the oil pump vacuum test port [1] and the boiler operated to check the vacuum readings. Oil pumps can operate if readings are between plus 0.4 bar and minus 0.35 bar.

This means oil tanks can be 4 metres higher (to top of oil) or 3.5 metres lower (if fitted with a de-aerator or two-pipe oil delivery system) than the oil pump.

If vacuum is greater than minus 0.35 bar then you must also check that the oil supply is not obstructed and that the oil supply pipe is correctly sized.

Accessory 8-716-116-333-0 is available to assist in connecting a vacuum gauge to the vacuum test port.

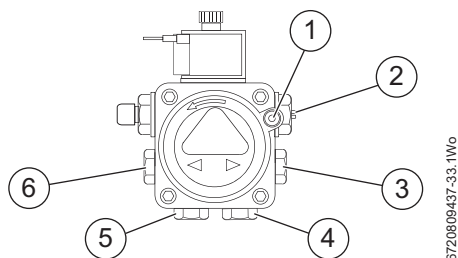

Fig. 92 Oil pump ports/connections

- [1] Vacuum gauge port
- [2] Pressure adjuster
- [3] Bleed and pressure gauge port
- [4] Return connection
- [5] Inlet connection
- [6] Auxiliary pressure gauge port

Notes

Notes

Notes

OIL BOILER COMMISSIONING CHECKLIST

This Commissioning Checklist is to be completed in full by the competent person who commissioned the boiler as a means of demonstrating compliance with the appropriate Building Regulations and then handed to the customer to keep for future reference.

BOILER DETAILS

Boiler Make and Model _____

Boiler Serial Number _____

COMMISSIONING ENGINEER

Company Name _____

Company Address _____

Telephone Number _____

Commissioned by (signature) _____

(print name) _____

Commissioning Date _____

COMMISSIONING CHECKS

Oil Type Used is Kerosene Yes

Pump Pressure _____ PSI

CO₂ _____ % CO _____ ppm CO/CO₂ ratio _____

Smoke Reading _____

Flue Gas Temperature _____ °C

Flue Pressure _____

Burner Model _____

CONTROLS Tick the appropriate boxes

Time and Temperature Control to Heating Room Thermostat and Programmer/Timer Programmable Room Thermostat Load/Weather Compensation Optimum Start Control

Time and Temperature Control to Hot Water Cylinder Thermostat and Programmer/Timer Combination Boiler

Heating Zone Valves Fitted Not Required

Hot Water Zone Valves Fitted Not Required

Thermostatic Radiator Valves Fitted Not Required

Automatic Bypass Valve Fitted to System Fitted Not Required

Boiler Interlock Provided

ALL SYSTEMS

The system has been flushed and cleaned in accordance with BS7593 and boiler manufacturer's instructions Yes

What system cleaner was used? _____

What inhibitor was used? _____ Quantity _____ litres

Has a system filter been fitted? Yes No

The condensate drain has been installed in accordance with the manufacturer's instructions and/or BS5546/BS6798 Yes

If the condensate pipe terminates externally has the pipe diameter been increased and weatherproof insulation fitted? Yes

CENTRAL HEATING MODE Measure and record

Central Heating Flow Temperature _____ °C

Central Heating Return Temperature _____ °C

DOMESTIC HOT WATER MODE Measure and record

Combination Boilers Only

Cold Water Inlet Temperature _____ °C

Hot Water Outlet Temperature _____ °C

Water Flow Rate _____ l/min

ALL INSTALLATIONS

Does the installation comply with current OFTEC Regulations? Yes No

The heating and hot water system complies with the appropriate Building Regulations Yes No

The boiler and associated products have been installed and commissioned in accordance with the manufacturer's instructions Yes No

The operation of the boiler and system controls have been demonstrated to and understood by the customer Yes No

IMPORTANT: LEAVE THIS MANUAL WITH THE HOMEOWNER

SERVICE INTERVAL RECORD

It is recommended that your heating system is serviced regularly and that the appropriate Service Interval Record is completed.

Service Provider

Before completing the appropriate Service Interval Record below, please ensure you have carried out the service as described in the manufacturer's instructions.

Always use the manufacturer's specified spare part when replacing controls.

Service 1

Date: _____

Engineer Name: _____

Company Name: _____

Telephone No. _____

OFTEC Register No. _____

Nozzle Changed? Yes No Pump Pressure: _____ *psi*

CO₂ _____ % CO _____ *ppm* CO/CO₂ ratio _____

F.G.T. _____ °C Flue Pressure: _____

Comments: _____

Signature: _____

Service 2

Date: _____

Engineer Name: _____

Company Name: _____

Telephone No. _____

OFTEC Register No. _____

Nozzle Changed? Yes No Pump Pressure: _____ *psi*

CO₂ _____ % CO _____ *ppm* CO/CO₂ ratio _____

F.G.T. _____ °C Flue Pressure: _____

Comments: _____

Signature: _____

Service 3

Date: _____

Engineer Name: _____

Company Name: _____

Telephone No. _____

OFTEC Register No. _____

Nozzle Changed? Yes No Pump Pressure: _____ *psi*

CO₂ _____ % CO _____ *ppm* CO/CO₂ ratio _____

F.G.T. _____ °C Flue Pressure: _____

Comments: _____

Signature: _____

Service 4

Date: _____

Engineer Name: _____

Company Name: _____

Telephone No. _____

OFTEC Register No. _____

Nozzle Changed? Yes No Pump Pressure: _____ *psi*

CO₂ _____ % CO _____ *ppm* CO/CO₂ ratio _____

F.G.T. _____ °C Flue Pressure: _____

Comments: _____

Signature: _____

Service 5

Date: _____

Engineer Name: _____

Company Name: _____

Telephone No. _____

OFTEC Register No. _____

Nozzle Changed? Yes No Pump Pressure: _____ *psi*

CO₂ _____ % CO _____ *ppm* CO/CO₂ ratio _____

F.G.T. _____ °C Flue Pressure: _____

Comments: _____

Signature: _____

Service 6

Date: _____

Engineer Name: _____

Company Name: _____

Telephone No. _____

OFTEC Register No. _____

Nozzle Changed? Yes No Pump Pressure: _____ *psi*

CO₂ _____ % CO _____ *ppm* CO/CO₂ ratio _____

F.G.T. _____ °C Flue Pressure: _____

Comments: _____

Signature: _____

Service 7

Date: _____

Engineer Name: _____

Company Name: _____

Telephone No. _____

OFTEC Register No. _____

Nozzle Changed? Yes No Pump Pressure: _____ *psi*

CO₂ _____ % CO _____ *ppm* CO/CO₂ ratio _____

F.G.T. _____ °C Flue Pressure: _____

Comments: _____

Signature: _____

Service 8

Date: _____

Engineer Name: _____

Company Name: _____

Telephone No. _____

OFTEC Register No. _____

Nozzle Changed? Yes No Pump Pressure: _____ *psi*

CO₂ _____ % CO _____ *ppm* CO/CO₂ ratio _____

F.G.T. _____ °C Flue Pressure: _____

Comments: _____

Signature: _____

Service 9

Date: _____

Engineer Name: _____

Company Name: _____

Telephone No. _____

OFTEC Register No. _____

Nozzle Changed? Yes No Pump Pressure: _____ *psi*

CO₂ _____ % CO _____ *ppm* CO/CO₂ ratio _____

F.G.T. _____ °C Flue Pressure: _____

Comments: _____

Signature: _____

Service 10

Date: _____

Engineer Name: _____

Company Name: _____

Telephone No. _____

OFTEC Register No. _____

Nozzle Changed? Yes No Pump Pressure: _____ *psi*

CO₂ _____ % CO _____ *ppm* CO/CO₂ ratio _____

F.G.T. _____ °C Flue Pressure: _____

Comments: _____

Signature: _____

If the boiler does not give complete satisfaction, before calling for a service engineer, the installer should check the following:

General checks

1. Is there 230 V across the boiler live and neutral terminals?
2. Is the polarity correct? (230 V across live and earth, 0 V across neutral and earth)
3. Is the air bled from the primary system?
4. Is the air bled from the oil supply?
5. Is the flue sized and routed correctly?

Boiler runs straight to lockout

1. Has the oil line been purged of air.
2. Where an air eliminator is used in conjunction with a top feed oil tank the non-return valve, (if fitted), should be removed from the oil dip pipe.

Boiler locks out at the start of a demand (Heating off over night for example)

1. If an air eliminator is being used, check that there are no leaks that allow air to be pulled into the oil supply.
2. If a two pipe oil supply is being used, has a non-return valve been fitted to the inlet pipe? Refer to the instructions for guidelines.

No domestic hot water

1. Is the mains water in connected to the 15 mm isolation valve?
2. Is there a domestic hot water demand from the programmer and has the tank reached temperature?

No domestic hot water (external programmer)

1. Is there 230 V on  ?



2. Refit link between  and  .



If the DHW now operates correctly there is a problem with the external programmer and/or its wiring.

No central heating

1. Are both programmer and room thermostat on demand for central heating?
2. Is the room thermostat wired correctly

No central heating (external programmer)

1. Is there 230 V on  ?



2. Refit link between  and  .



If the CH now operates correctly there is a problem with the external programmer and/or its wiring.



Under no circumstances must an appliance be left to operate with any control linked out or overridden.

WORCESTER, BOSCH GROUP:

TECHNICAL SUPPORT:	0330 123 3366
APPOINTMENTS:	0330 123 9339
SPARES:	0330 123 9779
LITERATURE:	0330 123 9119
TRAINING:	0330 123 0166
SALES:	0330 123 9669

Worcester, Bosch Group
Cotswold Way, Warndon, Worcester WR4 9SW.
Tel. 0330 123 9559

Worcester, Bosch Group is a brand name of Bosch Thermotechnology Ltd.
worcester-bosch.co.uk

6 720 813 345 (2014/09)

**WORCESTER**
Bosch Group