

Installation and Servicing Instructions

GREENSTAR HE combi



Wall mounted condensing boiler for central heating and mains fed domestic hot water



6 720 610 577-00.10

ZWB 7-27 HE combi GC-Number: 47 311 55



6 720 610 576 GB (02.05) OSW

**WORCESTER**
Bosch Group

Contents

Safety precautions 3

Symbols 3

1 Details of the appliance 4

1.1	EC Declaration of Conformity	4
1.2	Standard package	4
1.3	Description of appliance	4
1.4	Accessories	5
1.5	Casing dimensions	5
1.6	Layout of appliance	6
1.7	Function	7
1.8	Electrical wiring diagram	8
1.9	Technical data	9

2 Installation regulations 11

3 Installation 11

3.1	Important remarks	11
3.2	Domestic hot water	12
3.3	Sealed systems	12
3.4	Siting the appliance	13
3.5	Wall mounting frame assembly	14
3.6	Pre-piping the system	14
3.7	Fitting the appliance	15
3.8	Checking the connections	16
3.9	Flue Systems	16
3.9.1	Siting the Flue Terminal	17
3.9.2	Installation of the flue	18
3.9.3	Flue duct preparation and assembly	20

4 Electrical connections 21

4.1	Connecting the appliance	21
4.2	Mains Voltage external controls connections	22

5 Commissioning 23

5.1	Commissioning	23
5.2	Switching the appliance on/off	24
5.3	Switching on the central heating	24
5.4	System controls	24
5.5	Setting the domestic hot water temperature and flow rate	24
5.5.1	Domestic hot water temperature	24
5.5.2	Hot water flow rate	25
5.6	Summer mode (hot water only)	25
5.7	Frost protection	25
5.8	Pump anti-seize function	25
5.9	Fault Condition	25

6 Individual settings 26

6.1	Mechanical settings	26
6.1.1	Checking the size of the expansion vessel	26
6.1.2	Setting the central heating flow temperature	26
6.1.3	Changing the heating pump characteristic	26
6.2	Settings on the Bosch Heatronic	27
6.2.1	Operating the Bosch Heatronic	27
6.2.2	Selecting the pump control mode for central heating mode (Service Function 2.2)	27
6.2.3	Setting the anti-cycle time (Service Function 2.4)	27
6.2.4	Setting the maxim CH flow temperature (Service Function 2.5)	28
6.2.5	Setting the switching difference (Service Function 2.6)	28
6.2.6	Setting the heating output (Service Function 5.0)	28
6.2.7	Constant hot water cycle time (Service Function 6.8)	28
6.3	Setting the gas/air ratio	28

7 Converting the appliance to different gas types 29

7.1	Setting the gas/air ratio	29
7.2	Testing combustion air/flue gas at set heat output	31
7.2.1	Testing the O ₂ or CO ₂ level in the combustion air	31
7.2.2	Testing CO and CO ₂	31

8 Maintenance 32

8.1	Pre-Service Check List	33
8.2	Description of servicing operations	34
8.3	Replacement of Parts	38
8.3.1	PCB control board and transformer	38
8.3.2	Fan Assembly	39
8.3.3	Pump	39
8.3.4	3-way diverter valve	40
8.3.5	3-way diverter valve motor	40
8.3.6	Sensors	40
8.3.7	Gas Valve	41
8.3.8	Domestic Hot Water Heat Exchanger	41
8.3.9	Electrode assembly	41
8.3.10	Pressure gauge	41
8.3.11	Expansion vessel	41
8.3.12	Pressure Relief Valve	41
8.3.13	Burner	41
8.3.14	Flow switch	42
8.3.15	Primary Heat Exchanger	42

9 Appendix 43

9.1	Fault Codes	43
9.2	Short parts list	44
9.3	Heating/hot water output settings (N.G.)	45
9.4	Heating/hot water output settings (L.P.G)	45
9.5	Operational Flow diagrams	46
9.5.1	Domestic hot water function	46
9.5.2	Central heating function	47

Safety precautions

If you smell gas

- ▶ Turn off gas service cock at the meter.
- ▶ Open windows and doors.
- ▶ Do not operate any electrical switches.
- ▶ Extinguish any naked flames.
- ▶ Telephone your gas company.

If you smell fumes from the appliance

- ▶ Switch off appliance (see page 24).
- ▶ Open windows and doors.

Fitting and modifications

- ▶ Fitting of the appliance or any controls to the appliance may only be carried out by a competent engineer in accordance with the Gas Safety (Installation and Use) Regulations 1998.
- ▶ Flue systems must not be modified in any ways other than as described in the fitting instructions.
- ▶ This appliance is for use on sealed primary systems only.

Maintenance

- ▶ **The user is recommended:** to have the system regularly serviced in order to ensure that it functions reliably and safely.
- ▶ Use only original spare parts!

Combustible materials

- ▶ Do not store or use any combustible materials (paper, thinners, paints etc.) in the vicinity of the appliance.

Health and safety

- ▶ This appliance contains no asbestos products.
- ▶ There is no potential hazard due to the appliance being electrically unsafe.
- ▶ There are no substances used in the construction that are a potential hazard in relation to the COSHH Regulations (Control of Substances Hazardous to Health Regulations 1988).

Combustion air/Ambient atmosphere

- ▶ The combustion air/ambient atmosphere should be kept free of chemically aggressive substances (e.g. halogenated hydrocarbons which contain chlorine or fluorine compounds). This will prevent corrosion.

Instructions to the customer

- ▶ Explain to the customer how the appliance works and how to operate it.
- ▶ Advise the user that he/she must not make any modifications to the appliance or carry out any repairs on it
- ▶ These instructions are to be left with the user or at the Gas meter.
- ▶ Important: These instructions apply in the UK only.

Symbols



Safety instructions in this document are identified by a warning-triangle symbol and are printed on a grey background.



Notes containing important information are identified by the symbol shown on the left. They are bordered by horizontal lines above and below the text.

1 Details of the appliance

1.1 EC Declaration of Conformity

This appliance is in accordance with the applicable requirements of the Gas Appliance Directive, Boiler Efficiency Directive, Electromagnetic Compatibility Directive and the Low Voltage Directive.

PIN	CE-0085 BL 0507
Category UK	II _{2H} 3P
Appliance Type	C ₁₃ , C ₃₃

Table 1

1.2 Standard package

- Gas condensing combination boiler for central heating and domestic hot water
- Wall mounting frame
- Clamp for securing flue duct kit
- Fixings (screws etc.)
- Set of documentation for appliance
- Pre-plumbing manifold
- Condensate drain pipe.

1.3 Description of appliance

- Wall-mounted appliance, siting not dependent on room size
- Natural gas models are low-emission appliances
- Multifunction display
- Bosch Heatronic control system
- Automatic ignition
- Modulating control
- Full safety systems incorporating Bosch Heatronic with flame ionisation monitoring, solenoid valves and temperature sensors
- Concentric flue/air duct with testing point for CO₂/CO
- Regulated speed fan
- Pre-mix burner
- Temperature control for central heating
- Temperature sensor in domestic hot water
- Safety temperature limiter in 24 V electrical circuit
- Three-speed central heating pump with automatic vent
- Relief valve, pressure gauge, expansion vessel
- Flue gas temperature limiter (105 °C)
- Hot water priority circuit
- Motorised 3-way valve
- Plate-type heat exchange
- Condensate Trap.

1.4 Accessories

- Standard horizontal flue kit at 100 mm outside diameter for flues upto 4 m in length.
- Flue duct kits for horizontal (125 mm outside diameter) for flue lengths upto 13 m and vertical flue systems for flue lengths upto 15 m. Fitting instructions are sent with these kits.
- Heating programmer
- Timer
- Security kit.

1.5 Casing dimensions

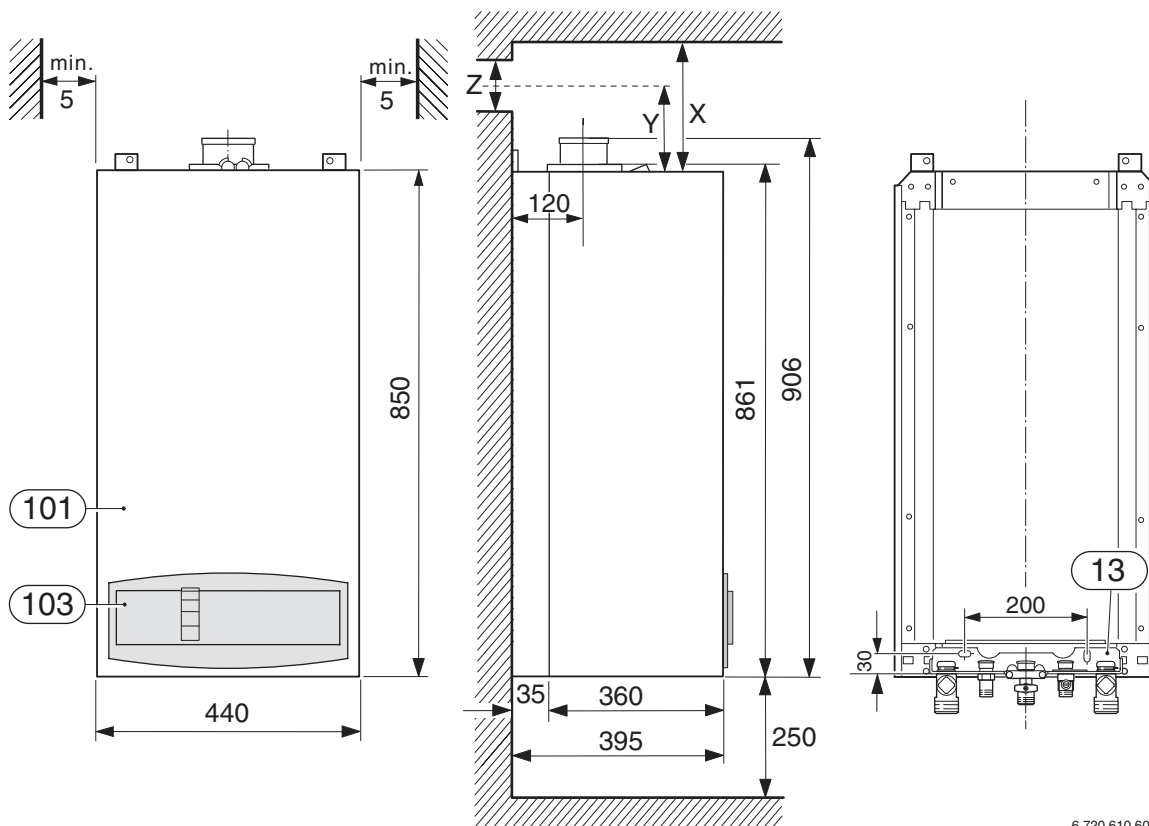

6 720 610 601-01.10

Fig. 1

- 13** Manifold assembly
- 101** Outer case
- 103** Facia cover
- X** Standard Concentric Horizontal Flue System: min. 310 mm
Alternative Concentric Flue System: min. 250 mm
- Y** Standard Concentric Horizontal Flue System: 158 mm
Alternative Concentric Flue System: 121 mm
- Z** Standard Concentric Horizontal Flue System: 105 mm
Alternative Concentric Flue System: 130 mm

1.6 Layout of appliance

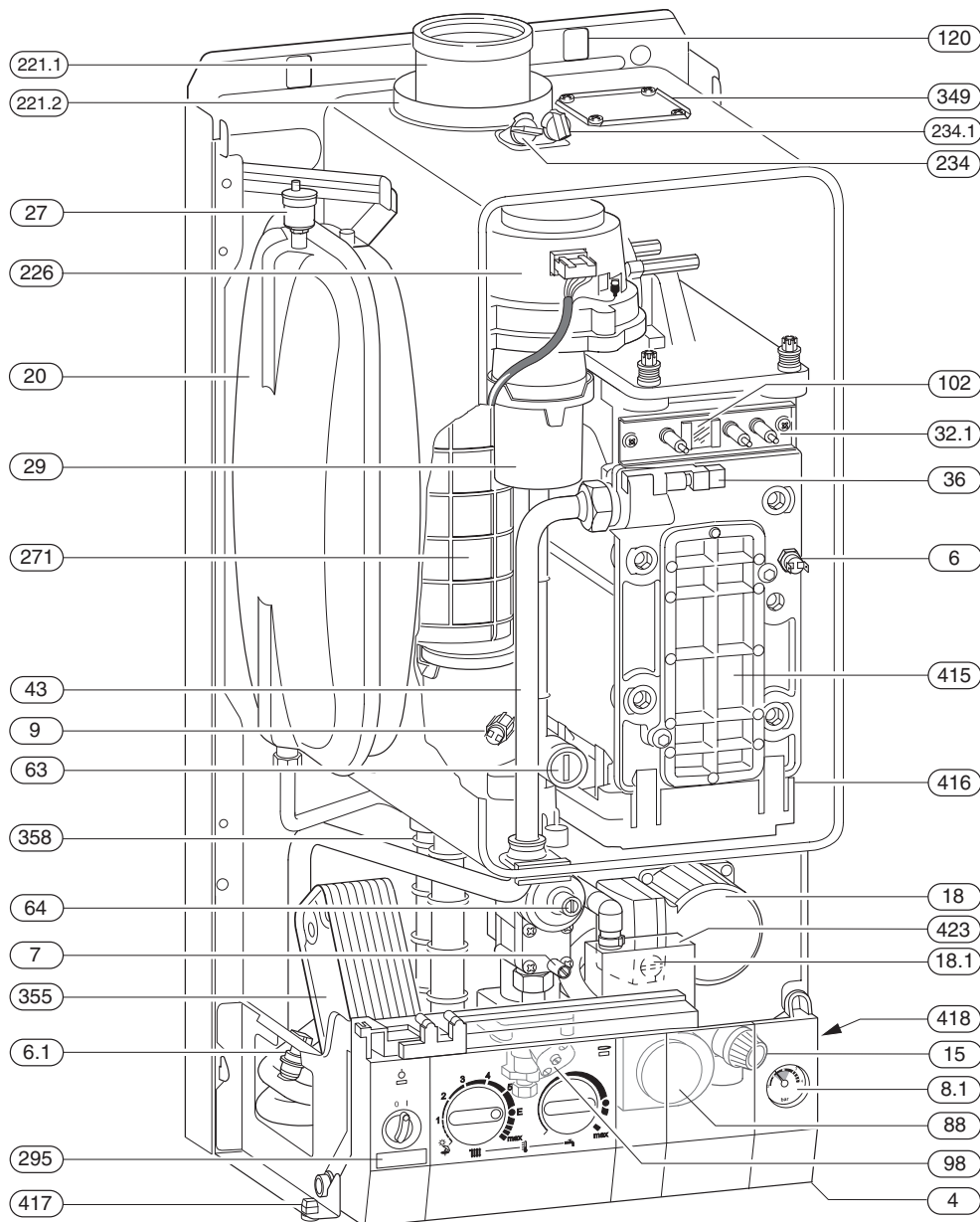

6 720 610 576-02.20

Fig. 2

4	Heatronic control	102	Inspection window
6	Heat exchanger safety temperature limiter	120	Fixing points
6.1	Hot water NTC sensor	221.1	Flue duct
7	Testing point for gas supply pressure	221.2	Combustion air intake
8.1	Pressure gauge	226	Fan assembly
9	Flue gas temperature limiter	295	Appliance type sticker
15	Relief valve	234	Testing point for combustion products
18	Pump	234.1	Testing point for combustion air
18.1	Pump speed selector switch	271	Flue duct
20	Expansion vessel	349	Cover plate for twin flue duct connection
27	Automatic air vent	355	Plate-type domestic hot water heat exchanger
29	Air gas Mixer unit	358	Condensate trap
32.1	Electrode assembly	415	Cover plate for cleaning access
36	Temperature sensor in CH flow	416	Condensate collector
43	CH flow	417	Clip for fixing outer case
63	Adjustable gas flow restrictor	418	Data plate
64	Adjusting screw for min. gas flow volume	423	Siphon
88	3-way valve (combi)		
98	DHW flow switch (combi)		

1.7 Function

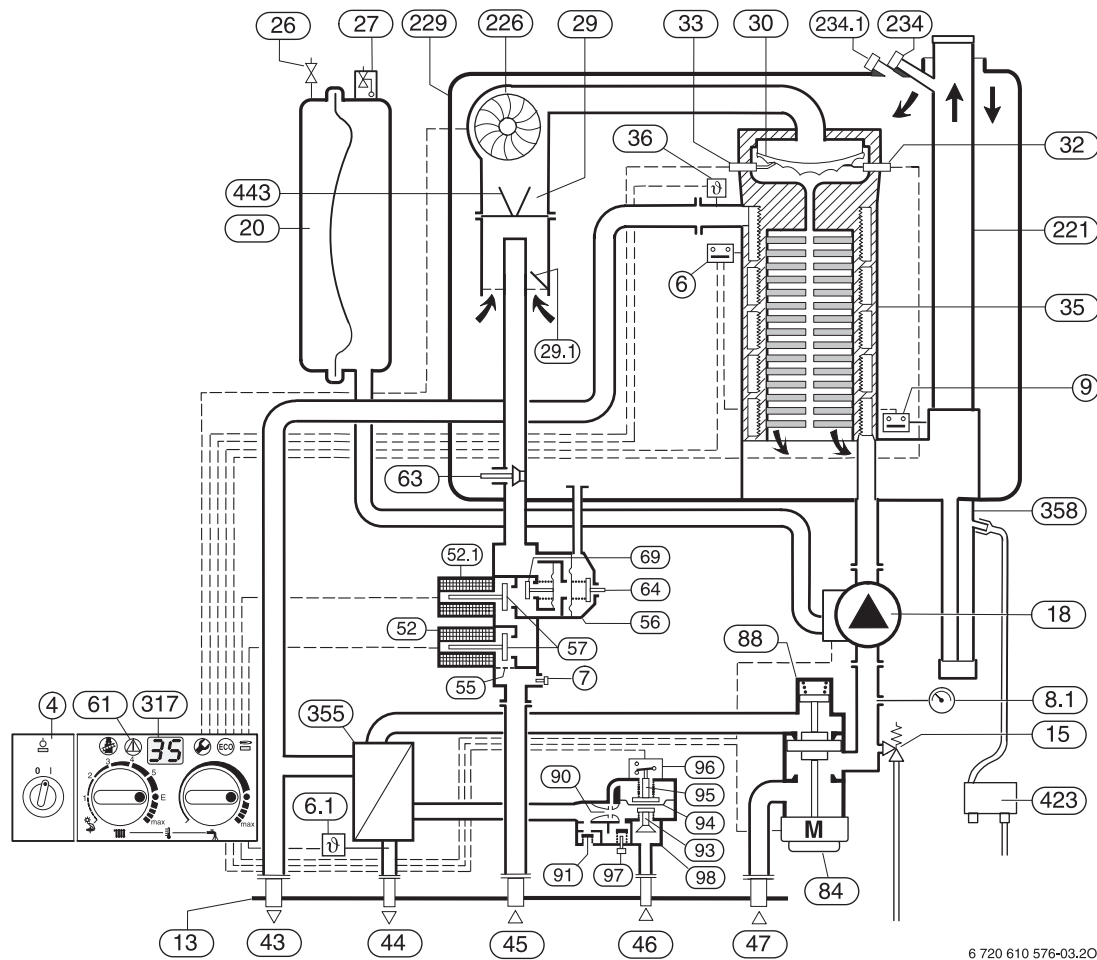
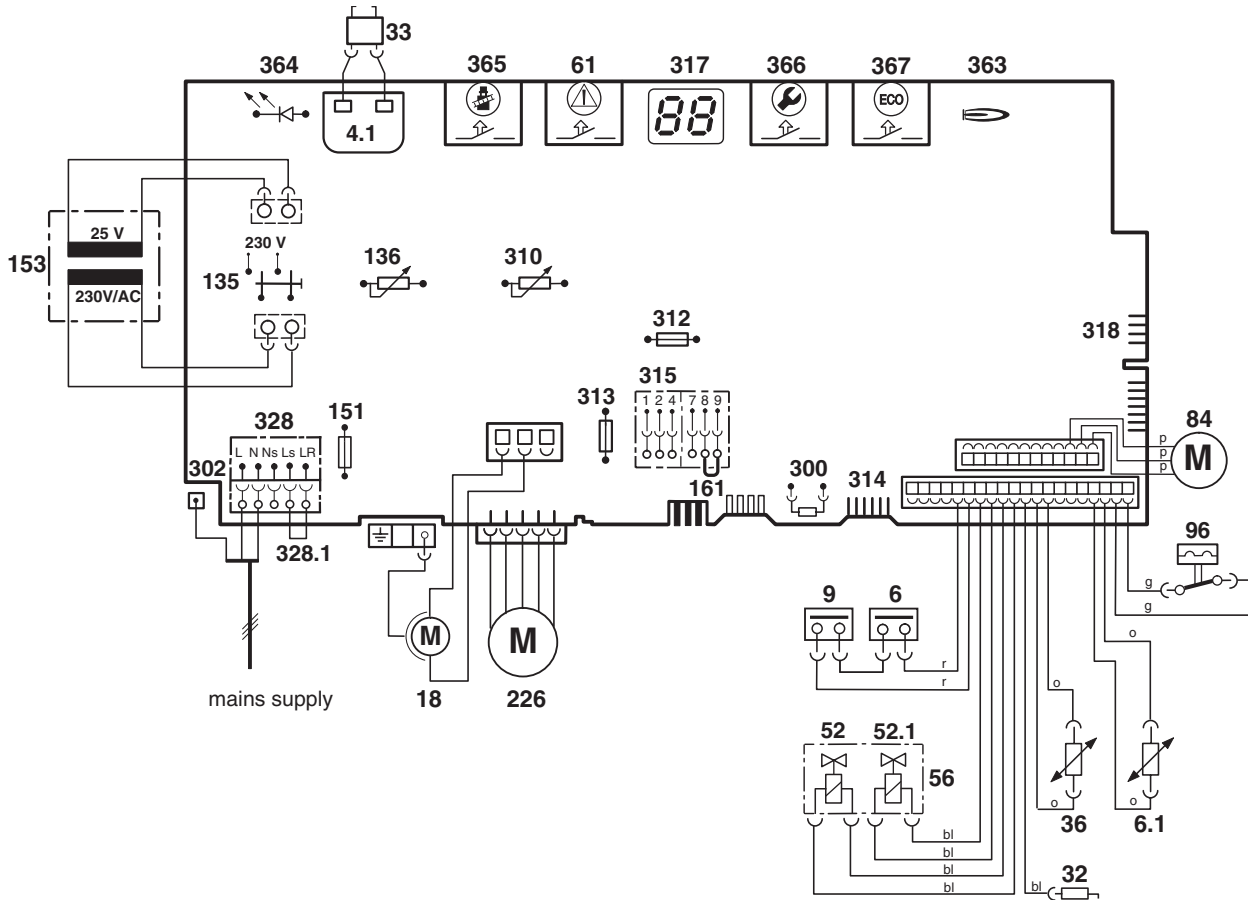

Fig. 3

- | | | | |
|------|--------------------------------------------------------|-------|------------------------------------------------|
| 4 | Bosch Heatronix control | 63 | Adjustable gas flow restrictor |
| 6 | Temperature limiter, heat exchanger | 64 | Adjusting screw for min. gas inlet flow volume |
| 6.1 | Hot water NTC sensor | 69 | Control valve |
| 7 | Testing point for gas supply pressure | 84 | Motor |
| 8.1 | Pressure gauge | 88 | 3-way valve |
| 9 | Flue gas temperature limiter | 90 | Venturi |
| 13 | Manifold | 91 | Pressure relief valve |
| 15 | Safety valve | 93 | Water flow regulator |
| 18 | Central heating pump | 94 | Diaphragm |
| 20 | Expansion vessel | 95 | Pushrod with switch cam |
| 26 | Charging valve | 96 | Microswitch |
| 27 | Automatic vent | 97 | Valve for hot water flow volume |
| 29 | Mixer unit | 98 | Water valve |
| 29.1 | Bi-metallic thermostat for combustion air compensation | 221 | Flue duct |
| 30 | Burner | 226 | Fan |
| 32 | Flame sensing electrode | 229 | Inner casing |
| 33 | Igniter electrode | 234 | Testing point for flue gas |
| 35 | Heat exchanger with cooled combustion chamber | 234.1 | Testing point for combustion air |
| 36 | Temperature sensor in CH flow | 317 | Display |
| 43 | CH flow | 355 | Plate-type heat exchanger |
| 44 | Hot water flow | 358 | Condensate trap |
| 45 | Gas inlet | 423 | Siphon |
| 46 | Cold water inlet | 443 | Diaphragm |
| 47 | CH return | | |
| 52 | Solenoid valve 1 | | |
| 52.1 | Solenoid valve 2 | | |
| 55 | Filter | | |
| 56 | Gas valve CE 427 | | |
| 57 | Main valve disc | | |
| 61 | Reset button | | |

1.8 Electrical wiring diagram

o - orange g - green bl - black r - red p - purple



6 720 610 576-08.20

Fig. 4

- | | | | |
|-------------|-------------------------------------|--------------|------------------------------------------|
| 4.1 | Ignition transformer | 161 | Link |
| 6 | Temperature limiter, heat exchanger | 226 | Fan |
| 6.1 | Hot water NTC sensor | 300 | Code plug |
| 9 | Flue gas temperature limiter | 302 | Earth connection |
| 18 | Pump | 310 | Temperature control for hot water |
| 32 | Flame sensing electrode | 312 | Fuse, slow T 1,6 A |
| 33 | Ignition electrode | 313 | Fuse, slow T 0,5 A |
| 36 | Temperature sensor in CH flow | 314 | Connector for programmer |
| 52 | Solenoid valve 1 | 315 | Terminal block for programmer |
| 52.1 | Solenoid valve 2 | 317 | Digital display |
| 56 | Gas valve CE 427 | 318 | Connector for timer |
| 61 | Reset button | 328 | Terminal block for AC 230 V Mains supply |
| 84 | Motor, 3-way valve | 328.1 | Link |
| 96 | Microswitch, hydraulic switch | 363 | Indicator lamp for burner |
| 135 | Master switch | 364 | Indicator lamp for power supply |
| 136 | Temperature control for CH flow | 365 | "Chimney sweep" button |
| 151 | Fuse, slow 2.5 A, AC 230 V | 366 | Service button |
| 153 | Transformer | 367 | ECO button |

1.9 Technical data

	Units	Natural gas	Propane
Max. rated heat output net 40/30°C central heating	kW	29.1	29.1
Max. rated heat output net 50/30°C central heating	kW	28.8	28.8
Max. rated heat output net 80/60°C central heating	kW	27.2	27.2
Max. rated heat input net	kW	27.5	27.5
Min. rated heat output net 40/30°C	kW	8.4	11.6
Min. rated heat output net 50/30°C	kW	8.3	11.4
Min. rated heat output net 80/60°C	kW	7.4	10.5
Min. rated heat input net	kW	7.6	10.8
Max. rated heat output net, domestic hot water	kW	27.2	27.2
Max. rated heat input net, domestic hot water	kW	27.5	27.5
Maximum gas flow rate – After 10 minutes from lighting			
Natural gas G20 ($H_{is} = 9,5 \text{ kWh/m}^3$)	m ³ /h	2.9	-
LPG ($H_i = 12,9 \text{ kWh/kg}$)	kg/h	-	2.1
Gas supply pressure			
Natural gas G20	mbar	20	-
LPG	mbar	-	37
Expansion vessel			
Charge pressure	bar	0.75	0.75
Total capacity	l	10	10
Hot water specifications			
Hot water flow rate (factory setting)	l/min	8	8
Max. hot water flow rate	l/min	14	14
Outlet temperature range	°C	40 - 60	40 - 60
Max. permissible water supply pressure	bar	10	10
Min. inlet pressure	bar	0.2	0.2
Specific flow rate	l/min	12.4	12.4
Flue			
Flue gas temp. 80/60°C, rated/min. load	°C	67/55	67/55
Flue gas temp. 40/30°C, rated/min. load	°C	43/32	43/32
Residual delivery pressure (inc. pressure drop in air intake duct)	Pa	80	80
CO ₂ level at max. rated heat output	%	9.5	11.3
CO ₂ level at min. rated heat output	%	9.2	11.0
NO _x -class		5	5
SEDBUK figure, Band A	%	90.6	90.6
Condensate			
Max. condensation rate ($t_R = 30^\circ\text{C}$)	l/h	2.3	2.3
pH-value, approx.		4.8	4.8
General Data			
Electrical power supply voltage	AC ... V	230	230
Frequency	Hz	50	50
Max. power consumption	W	101	101
Noise output level	dB(A)	36	36
Appliance protection rating	IP	X4D	X4D
Max. CH flow temperature	°C	nom. 90	nom. 90
Max. permissible operating pressure (CH)	bar	2.5	2.5
Permissible ambient temperatures	°C	0 - 60	0 - 60
Nominal capacity of appliance	l	3.75	3.75
Weight (excluding packing)	kg	46	46

Table 2

Condensate analysis, mg/l

Ammonium 1.2	Nickel 0.15
Lead ≤ 0.01	Mercury ≤ 0.0001
Cadmium ≤ 0.001	Sulphate 1
Chromium ≤ 0.005	Zinc ≤ 0.015
Halogenated hydrocarbons ≤ 0.002	Tin ≤ 0.01
Hydrocarbons 0.015	Vanadium ≤ 0.001
Copper 0.028	pH-value 4.8

Table 3

Flue system

HORIZONTAL 100 mm - Standard			
Overall Diameter of Duct	mm	100	Max. 4 m
Flue Terminal / Duct Assembly Length	mm	750	
Extension Duct Length	mm	1000	

Table 4

ALTERNATIVE HORIZONTAL 125 mm FLUE SYSTEM			
Overall Diameter of Duct	mm	125	Max. 13 m (including turret)
Flue Terminal / Duct Assembly	mm	550	
Extension Duct Length - Fixed	mm	200	
Extension Duct Length - Fixed	mm	450	
Extension Duct Length - Fixed	mm	950	
Extension Duct Length - Fixed	mm	1950	
Extension Duct Length - Telescopic	mm	265-375	
Extension Duct Length - Adjustable (Cut to length)	mm	200	

Table 5

VERTICAL 125 mm FLUE SYSTEM

Overall Diameter of Duct	mm	125	Max. 15 m
Flue Terminal / Duct Assembly	mm	1360	
Extension Duct Length	mm	200	
Extension Duct Length - Fixed	mm	450	
Extension Duct Length - Fixed	mm	950	
Extension Duct Length - Fixed	mm	1950	
Extension Duct Length - Telescopic	mm	265-375	
Extension Duct Length - Adjustable (Cut to length)	mm	450	

Table 6

Elbow - 90 ° Bend - 45 °
Equivalent length 2 m Equivalent length 1 m

Gas supply

Total length of gas supply pipe (metres)			Pipe diameter (mm)
3	6	9	
Gas discharge rate (m ³ /h)			
8.7	5.8	4.6	22
18.0	12.0	9.4	28

Table 7

Domestic water performance

Domestic Water Flow Rate l/min	Temperature Rise	30 °C	13.2
	Temperature Rise	35 °C	11.3
	Temperature Rise	40 °C	9.9
Maximum Mains pressure		bar	10.0
Minimum Mains pressure		bar	0.2

Table 8

2 Installation regulations

Gas Safety (Installation & Use) Regulations 1998: All gas appliances must be installed by a competent person. Failure to install correctly could lead to prosecution.

The manufacturers notes must not be taken, in any way, as overriding statutory obligations.

The appliance must be installed in accordance with the current IEE Wiring Regulations, local Building Regulations, Building Standards (Scotland) (Consolidation), bye-laws of the local Water Company, Health and Safety Document 635 (Electricity at Work Regulations 1989) and any other local requirements.

Product Liability regulations indicate that, in certain circumstances, the installer can be held responsible, not only for mistakes on his part but also for damage resulting from the use of faulty materials. We advise the installer to avoid any risk by using only quality approved branded fittings.

The relevant British Standards should be followed i.e.

- BS 6798: Specification for the installation of gas fired hot water boilers of rated input not exceeding 60kW
- BS 5449: Central Heating for Domestic Premises
- BS 5546: Installation of gas hot water supplies for domestic purposes
- BS 5440:1: Flues and ventilation for gas appliances of rated input not exceeding 70 kW (gross): Flues
- BS 5440:2: Flues and ventilation for gas appliances of rated input not exceeding 60 kW (gross): Air Supply
- BS 6891: Installation of low pressure gas pipework installations up to 28mm (R1).
- BS 7074:1: Code of practice for domestic heating and hot water supply.

These instructions must be followed.

3 Installation



- ▶ Always turn off the gas cock before carrying out any work on components which carry gas.



Fixing of the appliance, gas and flue connections, commissioning of the system and electrical connections may only be carried out by competent persons authorised by CORGI.

3.1 Important remarks

- ▶ Appliance should only be installed in sealed central heating systems.
- ▶ To avoid gas formation in the system, galvanised radiators or pipes must not be used.
- ▶ If a room thermostat is used: do not fit a thermostatic radiator valve on the radiator in the primary room.
- ▶ Add a suitable anti-freeze fluid compatible with aluminium to the water in the central heating system. Suitable products are available from Betz-Dearbon Tel.: 0151 4209563 and Fernox Tel.: 01799 550811.
- ▶ In our experience, the addition of sealing agents to the water in the central heating system can cause problems (deposits in the heat exchanger). For that reason we advise against their use.

3.2 Domestic hot water

Any regulations specified by the local water company must be observed.

The final 600 mm of the mains cold water connection to the appliance should be made in copper tube only.

The appliance is suitable for a mains supply having a maximum pressure of 10 bar. A pressure reducing valve must be fitted, if necessary.

The hot water outlet temperature is set to be capable of achieving a maximum of 60°C. The maximum temperature and the frequency of the recharge of the heat store may be reset.

The maximum water flow rate is factory set at 9.9 l/min to give temperature rise of 40°C. If a higher rise is required then the flow must be reduced at the tap and the discharge temperature will rise up to the maximum set figure.

The temperature rise, upto the maximum set by the user, is automatically maintained by the modulation of the heat input. In winter, when the mains temperature is very low, the water flow, adjusted at the tap or shower, should be reduced to maintain the required delivery temperature.

It is suggested that long pipe runs to taps or showers be insulated to prevent the rapid cooling of the water.

All types of single lever mixer taps and thermostatic mixer units suitable for a mains pressure of up to 10 bar can be used.

The head of a loose-head shower must not be allowed to fall within 25 mm of the top the bath to prevent the risk of water being drawn back into the mains. Alternatively the shower must be fitted with an anti-syphonage device at the point of the flexible hose connections.

Over-rim bidets may be connected to the appliance provided that it is in accordance with the requirements of the local water company. The outlet(s) should be shrouded and unable to have any temporary hand held spray attached. No anti-syphonage arrangements are necessary.

In exceptionally hard water areas a device to prevent scale formation may be fitted or, alternatively, the maximum temperature reset to about 45°C which may reduce the risk of scale formation. The installation of a scale inhibitor assembly should be in accordance with the requirements of the local water company. Artificially softened water must not be used to fill the central heating system. An isolating valve should be fitted to allow for servicing.

Devices, such as water meters or back-flow prevention valves, capable of preventing the flow of expansion water must not be fitted unless separate arrangements have been made.

A Zilmet Z160 expansion vessel is the preferred type. A thread sealant compatible with potable water must be used.

3.3 Sealed systems

The appliance must not be operated without the system being full of water, properly vented and pressurised.

The expansion vessel has a volume of 10 litres and is charged to a pressure of 0.75 bar.

The water capacity of the system is shown in table 11, page 26. If a greater capacity is required then an additional expansion vessel must be fitted into the system return as close to the appliance as possible. The system pressure can be set up to a maximum of 1.5 bar with 1 bar being the normal setting.

If the system pressure is greater than 2.65 bar when the appliance is operating at maximum temperature then an additional expansion vessel must be fitted into the system return as close to the appliance as possible.

The filling point must be at low level and arranged as shown in figs. 5 and 6.

The pressure relief valve is set to operate at 3 bar.

There must be no connection to the mains without the approval of the local water company. All connections in the system must be capable of withstanding a pressure of up to 3 bar and the radiator valves conform to the requirements of BS 2767:10.

If Thermostatic Radiator Valves are fitted then it is recommended that one radiator is left open.

Repeated venting probably indicates a leak and this must be rectified to ensure the proper operation of the appliance.

No galvanised radiators or pipes must be used.

If any system water treatment is required then only products suitable for use with Aluminium shall be used i.e Fernox- Copal or Sentinal X100, in accordance with the manufacturers instructions. The use of any other substances will invalidate the guarantee. The pH value of the system water must be less than 8 or the appliance guarantee will be invalidated.

A drain cock to BS2879 must be fitted to the lowest point of the system.

IMPORTANT: Check that no dirt is left in the water pipework as this could damage the appliance. Thoroughly flush the heating system and the mains water supply before fitting the appliance to the wall in accordance with the recommendations of BS7593:1992.

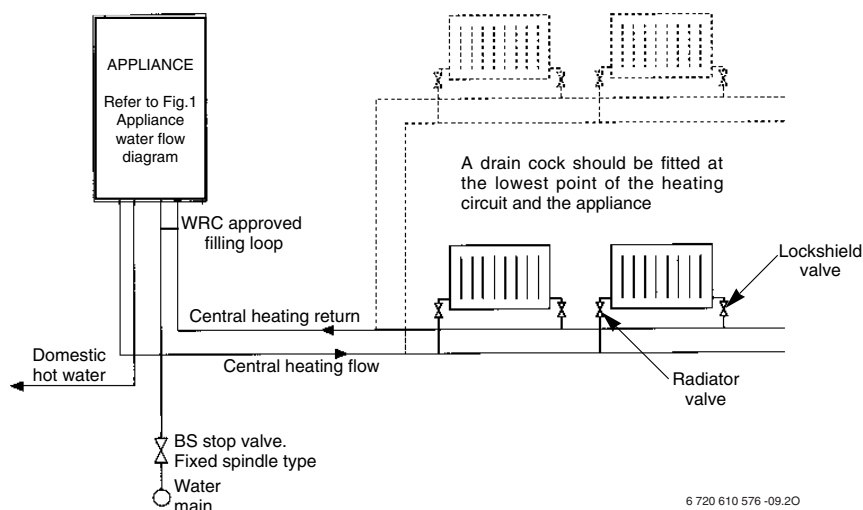

Fig. 5 Sealed primary water system

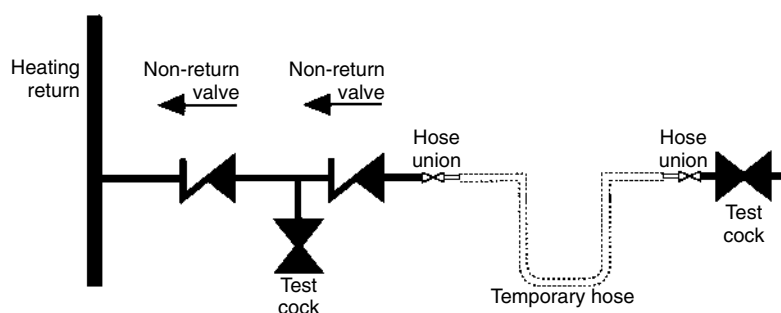

Fig. 6 Sealed primary water system - filling method

3.4 Siting the appliance

Regulations concerning the Installation Site

- ▶ Relevant national regulations must be complied with section 3.9.1.
- ▶ Consult the installation instructions for details of minimum clearances required.

Combustion air

In order to prevent corrosion, the combustion air must not contain any corrosive substances.

Substances classed as corrosion-promoting include halogenated hydrocarbons which contain chlorine and fluorine compounds and are contained in some solvents, paints, adhesives, aerosol propellants and household cleaners, for example.

Surface temperature

The max. surface temperature of the casing and the flue is less than 85 °C.

This means that, no special safety precautions are required with regard to flammable building materials and fitted furniture. The specified clearances must be maintained.

Cupboard/Compartment

The appliance can be installed in a cupboard/compartment need for airing clothes providing that the requirements of BS6798 and BS5440:2 are followed. The low casing losses from the appliance eliminate the need for ventilation openings in the compartment.

3.5 Wall mounting frame assembly

- ▶ Take the wall mounting frame out of the package and screw together with 6 screws as shown in fig. 7. Use the inner lugs on the top and bottom horizontal sections for the appliances that are 440 mm wide.

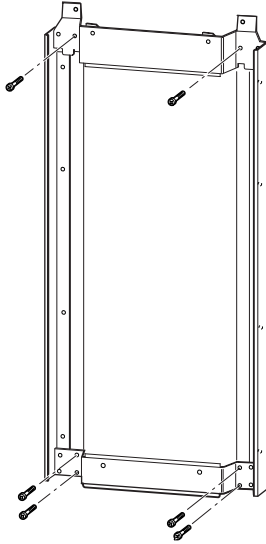

6 720 610 576-04.10

Fig. 7

- ▶ Hold the wall-mounting frame against the wall ensuring that it is vertical.
- ▶ Mark the position of the flue duct hole if a rear flue is to be used. Refer to fig. 1 and 15.
- ▶ Mark the holes for the wall mounting frame onto the wall, drill and plug the holes and screw the wall mounting frame to the wall with the screws provided.

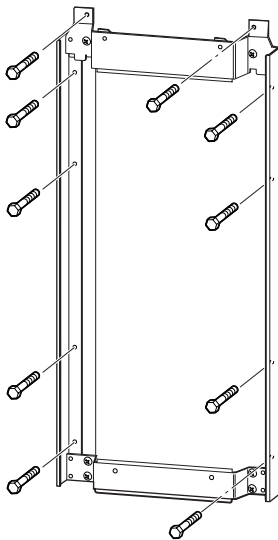

6 720 610 576-05.10

Fig. 8

- ▶ Screw the pre-plumbing manifold with two screws to the wall mounting frame.

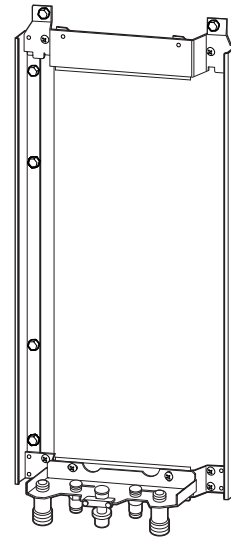

6 720 610 576-11.10

Fig. 9

3.6 Pre-piping the system

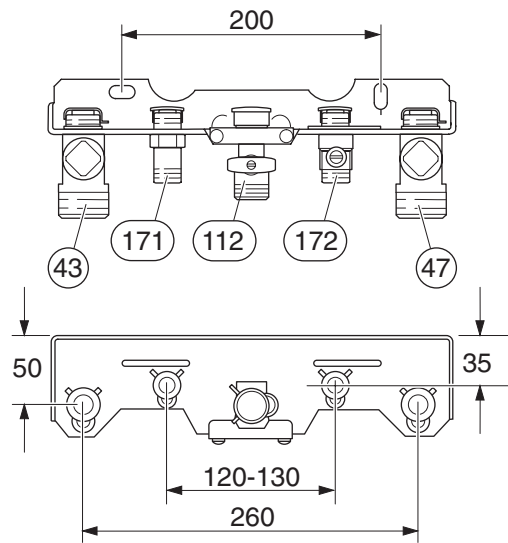

6 720 610 576-06.10

Fig. 10 Manifold

- 43 CH flow
- 47 CH return
- 112 Gas cock
- 171 Domestic hot water
- 172 Cold water relief

- ▶ A drain tap should be fitted at the lowest point of the central heating system.
- ▶ WRc filling loop must be fitted.

Condensate drain

Prepare the condensate discharge system. Refer to fig. 11. The condensate drainage pipe should be a standard drain pipe material, i. e. PVC, PVC-U, ABS etc. and should be at least 22 mm in diameter.

A siphon with a 75 mm condensate seal is fitted within the appliance.

A connection to an internal drain is recommended.

Any external drain pipe should be insulated to prevent freezing.

The connection of a condensate pipe to a drain may be subject to local building regulations.

For more information refer to the CIBSE Guide, BS5546 and the Building Regulations.

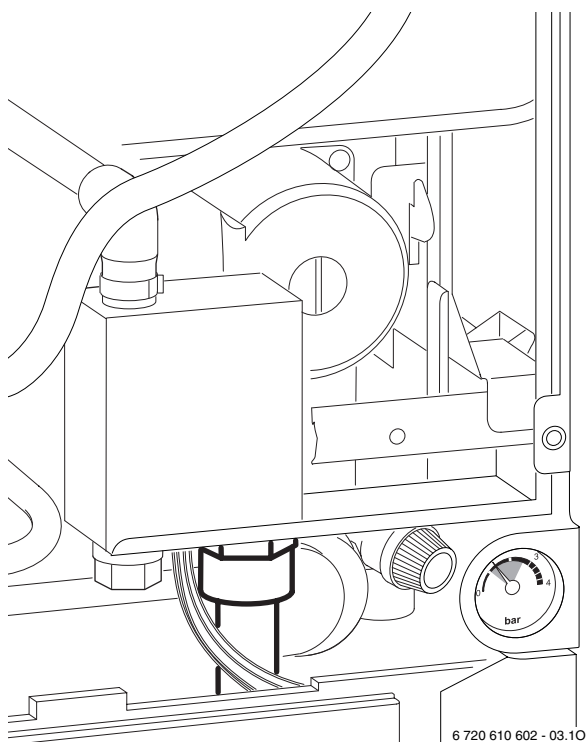

Fig. 11 Position of the condensate drain

3.7 Fitting the appliance



Benchmark: For optimum performance after installation, this boiler and its associated central heating system must be flushed in accordance with the guidelines given in BS5793:1992 "Treatment of water in domestic hot water central heating systems".

- ▶ Remove packing, taking care to observe the instructions on the packing.
- ▶ Lie the boiler on its back.

Removing the outer case



The outer case is secured against unauthorised removal by two clips (electrical safety).

Always secure the outer case with those clips again after refitting.

- ▶ Turn the clips with a screwdriver (1.).
- ▶ Slide the outer case upwards and then forwards to remove (2.).
- ▶ Remove the plastic caps from the boiler connections.

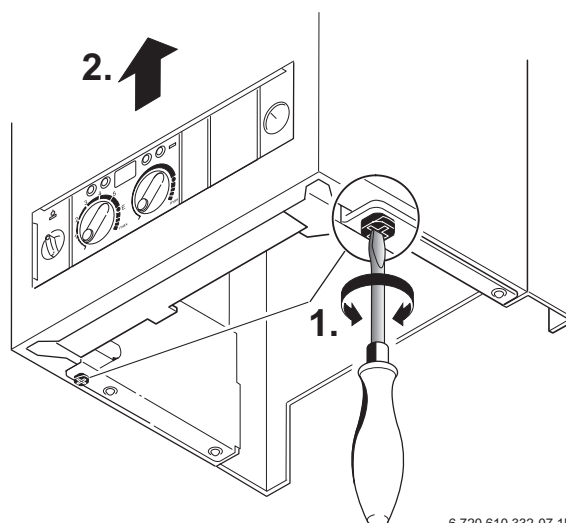

Fig. 12

Fixing the appliance

- ▶ Fit the washers onto the gas and water connections.
- ▶ Lift the boiler onto the wall-mounting frame. The lugs pass through the rectangular holes in the boiler back panel.
- ▶ Take care not to disturb the washers on the connections.

Connecting the flue duct

- ▶ Fit flue duct connector onto appliance flue spigot.
- ▶ Secure with the two screws supplied.

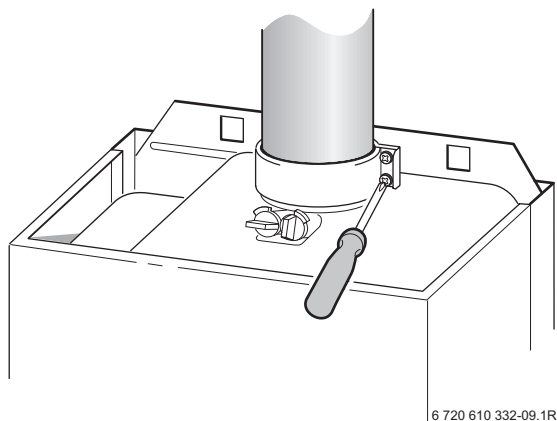

Fig. 13

- ▶ For remaining installation of flue assembly, refer to the relevant installation instructions.

3.8 Checking the connections

Water connections

- ▶ Check that the O-rings or seals are in place before tightening the connection.
- ▶ Turn on the service valves for central heating flow and return and fill the heating system through a WRC approved filling loop.
- ▶ Check all seals and unions for leaks (testing pressure max. 3.0 bar as indicated by pressure gauge).
- ▶ Turn on cold water service cock and fill hot water system (testing pressure max. 10 bar).
- ▶ Check all connections for leaks.

Gas supply pipe

- ▶ Check that the seal is in place before tightening the connection.
- ▶ Turn off gas cock to protect gas valve against damage from excessive pressure.
- ▶ Check gas supply pipe.
- ▶ Release the pressure on the gas supply pipe.

3.9 Flue Systems

The only flue systems that may be used are those supplied by Worcester Heat Systems.

The flue system must be installed in accordance with the requirements of BS5440:1.

Standard 100 mm flue system

The standard concentric flue system provides for a horizontal length of upto 4 m. Full instructions for fitting this flue are in Subsection 3.9.2 "Installation of the flue".

Alternative 125 mm diameter flue systems

Installation instructions for the alternative flue systems are sent with the appropriate flue kit.

Systems are available to give a maximum horizontal length of 13 m.

A vertical flue system upto a height of 15 metres is available.

45° and 90° flue bends can be used with a corresponding reduction in flue length of 2m for each 90° bend and 1 m for each 45° bend used.

IMPORTANT: Any horizontal flue system fitted to a condensing boiler must incline towards the appliance at an angle of 3 % (30 mm per metre length) to prevent condensate dripping from the flue terminal. **This means that the clearance above the appliance must be increased to match the duct length.** Refer to fig. 1 on page 5.

3.9.1 Siting the Flue Terminal

The flue must be installed in accordance with BS 5440:1 and the Building Regulations. Flue terminals in carports and under balconies are to be avoided.

The terminal must be positioned so that it does not cause an obstruction nor the combustion products a nuisance. See fig. 14 and table 9.

The terminal will, at times, give out a plume of water vapour and consideration must be given to this when choosing a terminal position. Keep clear of security

lighting, activated by passive infra-red sensing heads. If the terminal is less than 2 m above a surface to which people have access then a guard must be fitted. The guard must be evenly spaced about the terminal with a space of 50 mm in each direction and fixed with plated screws.

A guard Type K2 for the standard horizontal flue, can be obtained from Tower Flue Components, Vale Rise, Tonbridge TN9 1TB.

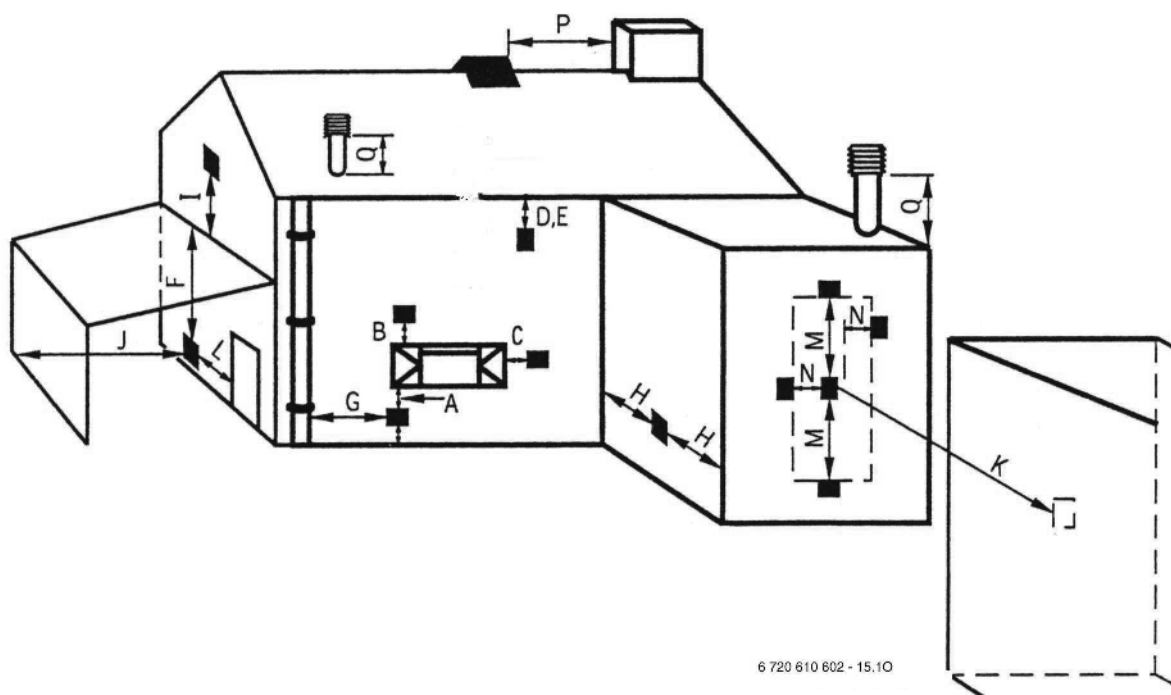

Fig. 14

Minimum dimensions of flue terminal positions (all types) (see fig. 14)

Dimension	Terminal Position (kW input expressed in net)	Balanced flues room sealed: Fanned draught
A ¹⁾	Directly below an opening, air brick, opening windows, etc.	300 mm
B ¹⁾	Above an opening, air brick, opening window, etc.	300 mm
C ¹⁾	Horizontally to an opening, air brick, opening window, etc.	300 mm
D	Below gutters, soil pipes or drain pipes	75 mm
E	Below eaves	200 mm
F	Below balconies or car port roof	200 mm
G	From a vertical drain pipe or soil pipe	150 mm
H	From an internal or external corner	300 mm
I	Above ground roof or balcony level	300 mm
J	From a surface facing the terminal	600 mm
K	From a terminal facing the terminal	1200 mm
L	From an opening in the car port (e. g. door, window) into the dwelling	1200 mm
M	Vertically from a terminal on the same wall	1500mm
N	Horizontally from a terminal on the same wall	300 mm
O	From the wall on which the terminal is mounted	Not applicable
P	From a vertical structure on the roof	Not applicable
Q	Above intersection with roof	Not applicable

Table 9

1) In addition, the terminal should not be nearer than 150 mm (fanned draught) to an opening in the building fabric formed for the purpose of accommodating a built-in element such as a window frame.

3.9.2 Installation of the flue

The standard 100 mm diameter horizontal flue system is suitable for lengths upto 4 m.

Flues upto 650 mm do not require an extension duct assembly.

Flues between 1600 mm and 4000 mm require extension duct assemblies.

NOTE: Flue lengths between 650 mm and 730 mm cannot be accommodated. Refer to fig. 16, 17, 18.

Standard system comprise: Flue turret - Flue turret clamp - Terminal assembly - Wall sealing - plates.
 Extension kit comprises: Air duct - Flue duct - Duct clamp. Refer to fig. 19.

Instructions for fitting other flue systems are packed with the relevant flue kit.

Check that the position chosen for the appliance is satisfactory Refer to fig. 15.

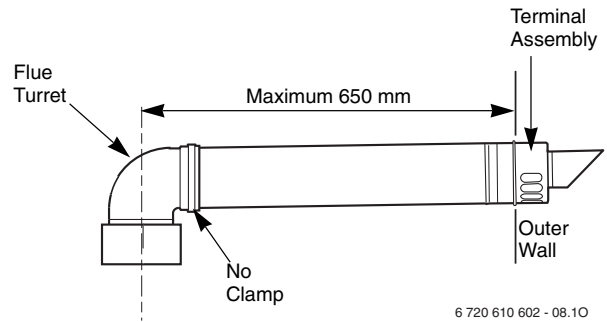

Fig. 16 Standard Flue

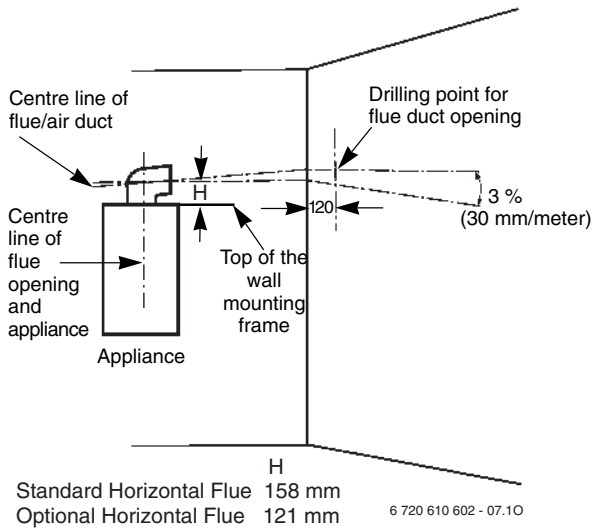
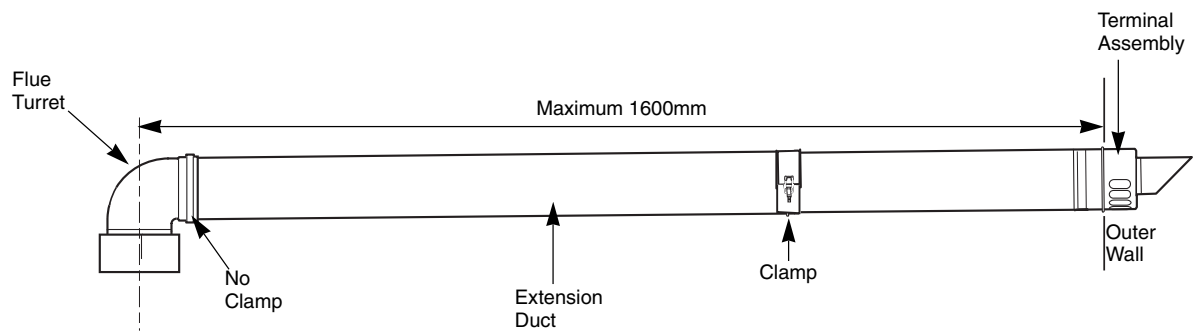
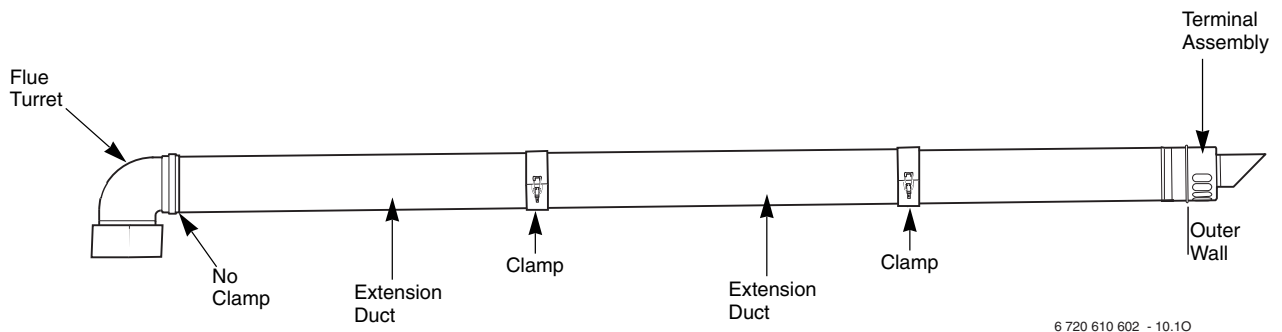

Fig. 15 Marking the position of the side flue opening



6 720 610 602 - 09.10

Fig. 17 Flue with one extension



6 720 610 602 - 10.10

Fig. 18 Flue with extensions

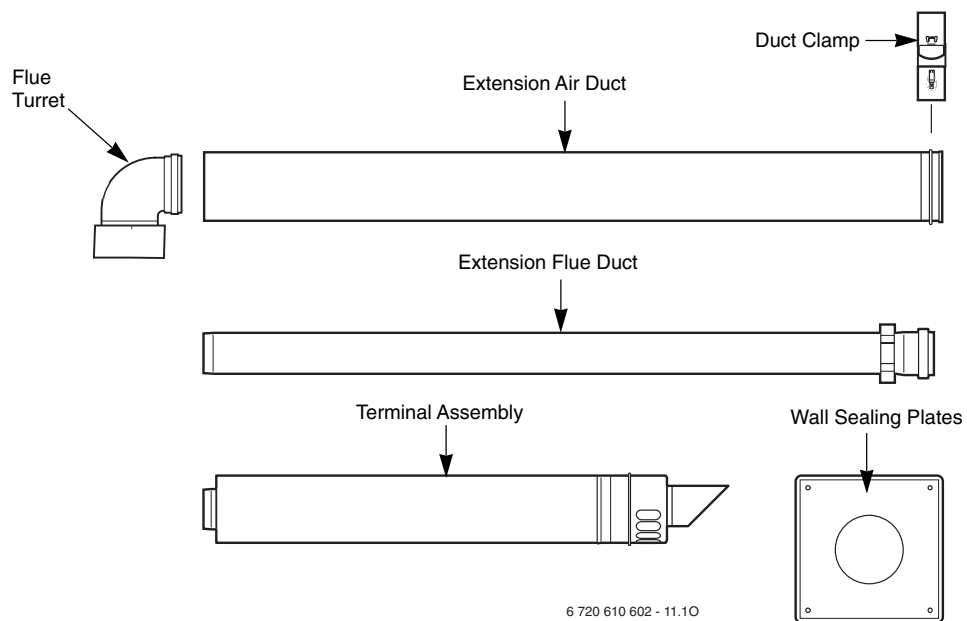

6 720 610 602 - 11.10

Fig. 19 Flue components

3.9.3 Flue duct preparation and assembly

Measure the flue length L. Refer to fig. 20, 21.

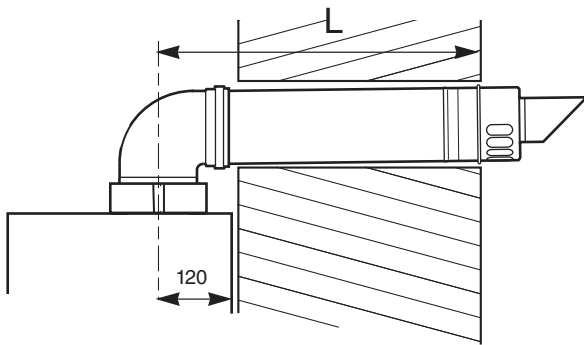

NOTE: THE FLUE MUST BE INCLINED TO THE BOILER
6 720 610 602 - 12.10

Fig. 20 Flue length - rear

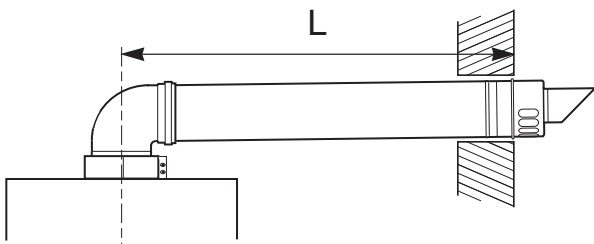

NOTE: THE FLUE MUST BE INCLINED TO THE BOILER
6 720 610 602 - 13.10

Fig. 21 Flue length - side

Mark off the lengths shown onto the ducts and cut to length. The cuts must be square and free from burrs. Terminal assembly outer (air) duct - L-70 mm, inner (flue) duct - L- 50 mm. The measurement is made from the ridge at the terminal indicating the outer face of the wall. Refer to fig. 22.

Extension air duct - L-70mm, flue duct - L-50 mm. The measurement is from the formed end.

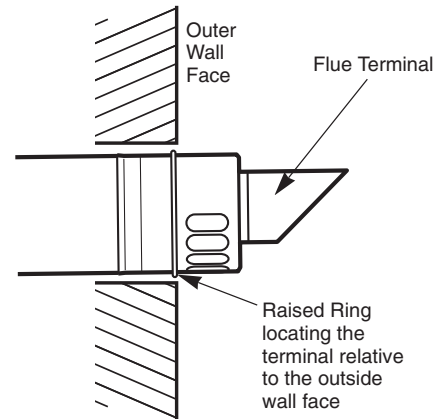

6 720 610 576 - 20.10

Fig. 22 Flue terminal position

Assemble flue system completely. Push the ducts fully together and clamp in the positions. The slope of the terminal outlet must face downwards.

The assembly will be made easier if a solvent free grease is lightly applied i.e Vaseline, to the male end of the ducts.

NOTE: An inner wall sealing plate is provided which should be fitted to the ducts before assembly.

Push the assembly through the wall and fix the turret to the appliance with the clamp. Refer to fig. 23.

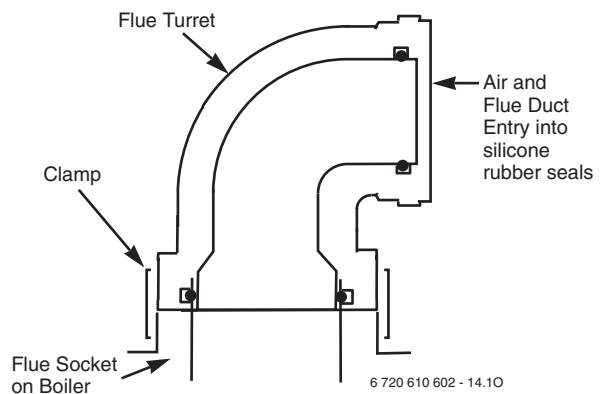

6 720 610 602 - 14.10

Fig. 23 Flue turret

Ensure that the turret is fully entered into the socket on the boiler. From the outside fix the outer wall plate to the terminal and, after ensuring the duct is properly inclined towards the boiler, fix the plate to the wall.

If the terminal is within 2 m of the ground where there is access then an approved terminal guard must be fitted. The guard must give a clearance of at least 50 mm around the terminal and be fixed with corrosion resistant screws.

4 Electrical connections



- ▶ Always disconnect the power supply to the appliance at the mains before carrying out any work on the electrical systems and components.

All control and safety systems are built into the appliance.

- ▶ Allow mains cable to protrude at least 50 cm from wall.
- ▶ To make splash-water proof (IP): cut the cable grommet hole size to match diameter of cable, see fig. 26.

It must be possible to isolate the appliance. The appliance must be earthed.

The appliance must be connected to the mains through a 6 A double pole isolator with a contact separation 3 mm in all poles and supplying the appliance and controls only. The wiring must comply with the current requirements of the IEE Wiring Regulations and any local regulations which apply.

- Supply: 230 V ~ 50 Hz, 140 Watts
- Mains cable: PVC insulated 0.75 mm² (24 x 0.20 mm) to BS6500-Table 6. Temperature rated 100°C.
- Protection IPX4D
- External fuse 3 A.

4.1 Connecting the appliance

To gain access to the mains connection remove the drop down facia cover. The drop down cover is removed by lowering it to the horizontal position and pushing firmly upwards at the rear of the supports to release the cover. Lift cover from the appliance.

After installation (or in the event of an electrical fault) the electrical system shall be checked for short circuits, fuse failure, incorrect polarity of connections, earth continuity and resistance to earth.

- ▶ Pull out cover panel at the bottom and remove. Refer to fig. 24.

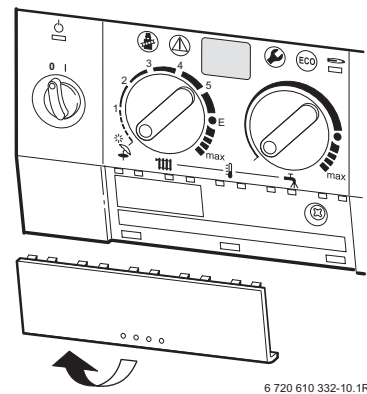

Fig. 24

- ▶ Remove screw and slide terminal cover forwards to remove. Refer to fig. 25.

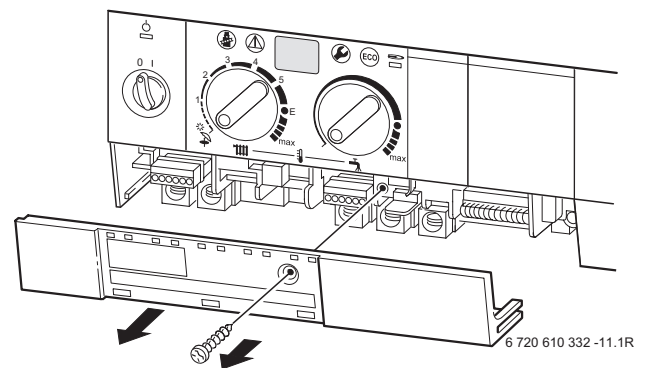

Fig. 25

- ▶ Cut cable grommet to diameter of cable.

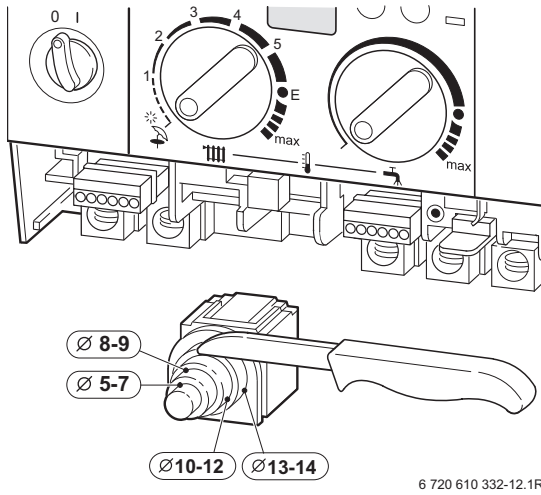

Fig. 26

- ▶ Feed cable through cable grommet and connect the mains supply cable, see fig. 27.
- ▶ Secure cable in cable grommet by means of cable grip.

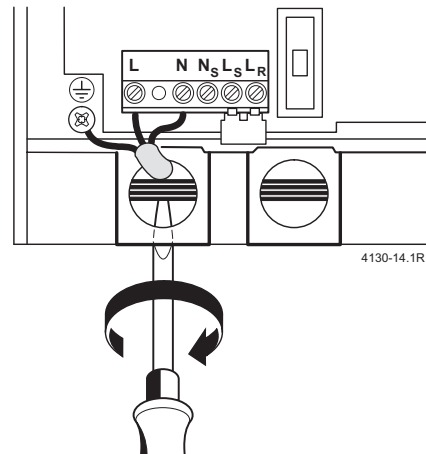

Fig. 27

4.2 Mains Voltage external controls connections

NOTE: Only double insulated controls not requiring an earth can be used

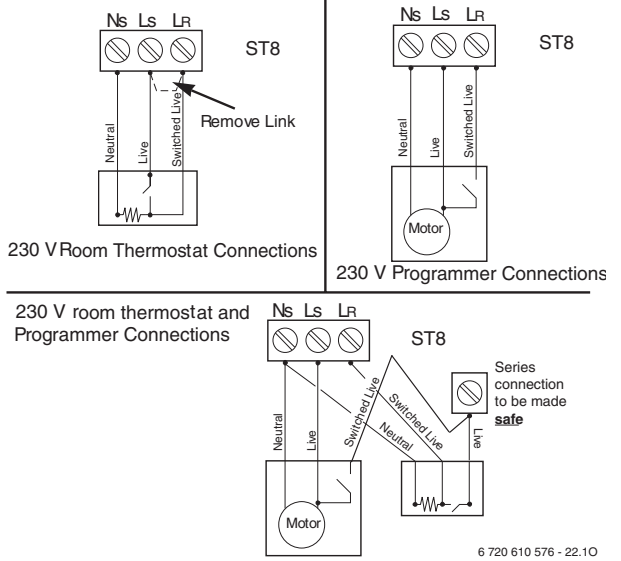
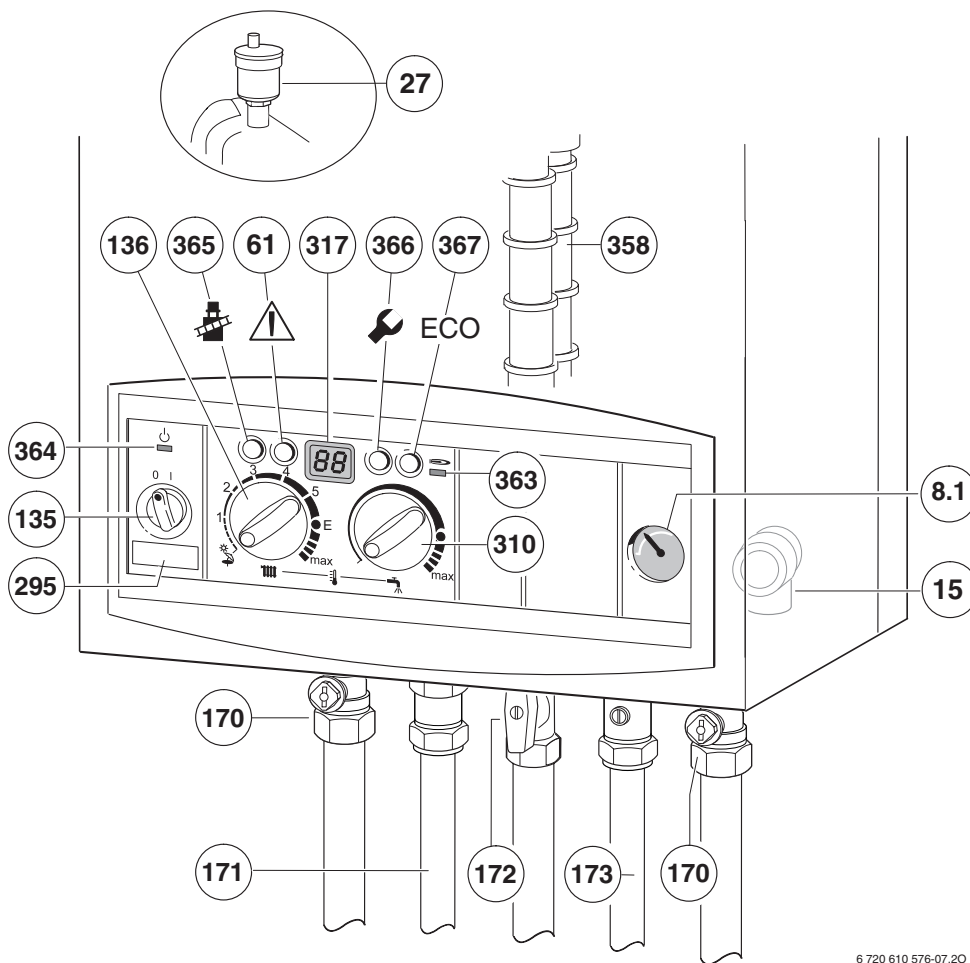

Fig. 28

5 Commissioning



6 720 610 576-07.20

Fig. 29

- 8.1 Pressure gauge
- 15 Safety valve
- 27 Automatic vent
- 61 Reset button
- 135 Master switch
- 136 Temperature control for central heating
- 170 Service cocks on CH flow and return
- 171 Hot water
- 172 Gas cock (shown in on position)
- 173 Cold water service cock
- 295 Appliance type sticker
- 310 Temperature control for hot water
- 317 Multifunction display
- 358 Condensate trap
- 363 Indicator lamp for burner
- 364 Indicator lamp for power supply
- 365 "Chimney sweep" button
- 366 Service button
- 367 ECO button

5.1 Commissioning



Never run the appliance when empty or unpressurised.

Benchmark Water Treatment: For optimum performance after installation, this boiler and its associated central heating system should be flushed in accordance with the guidelines given in BS7593:1992 - Treatment of water in domestic hot water systems. Full instructions are supplied with proprietary cleansers sold for this purpose. If an inhibitor is to be used after flushing, it should be used in accordance with the inhibitor manufacturers instructions.

To drain the appliance shut the system valves and open the pressure relief valve.

Suitable flushing agents and inhibitors are available from Betz/Dearborn Tel.: 0151 4209563 and Fernox Tel.: 01799 550811. Instructions for use are supplied with these products.

- Before commissioning, the gas supply pressure must be tested (see page 29).

- ▶ Unscrew the condensation trap (358) and pull out, fill with approx. 1/4 l of water and refit. Refer to fig. 29.
- ▶ Adjust charge pressure of expansion vessel to static head of the central heating system (see page 26).
- ▶ Open all system radiator valves.
- ▶ Turn on service valves (170), fill central heating system to pressure of 1 - 2 bar through the WRc approved filling loop. Refer to fig. 29.
- ▶ Vent radiators.
- ▶ Refill heating system and set the pressure to 1 bar.
- ▶ Turn on cold water service cock (173). Refer to fig. 29.
- ▶ Check that the gas type specified on the identification plate matches that of the gas supply.
- ▶ Turn on gas cock (172). Refer to fig. 29.

5.2 Switching the appliance on/off

Switching on

- ▶ Switch on the appliance at the master switch (I). The indicator lamp shows green and the display will show the central heating flow temperature, when the appliance is operating in the central heating mode.

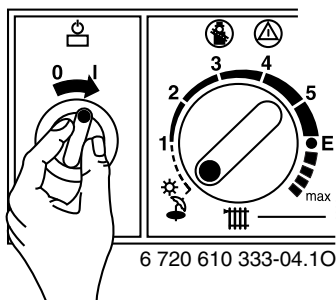

Fig. 30



If the display alternates between -II- and the central heating flow temperature, the trap filling programme is active.

The trap filling programme ensures that the condensation trap is filled after the appliance has been installed or after the appliance has been out of use for a long period or the mains supply has been interrupted. For that reason, the appliance remains at minimum heating output for 15 minutes.

Switching off the appliance

- ▶ Set the master switch to (0). The green indicator lamp goes out.



- ▶ Always disconnect the appliance from the power supply (fuse, circuit breaker) before carrying out any work on the electrical systems or components.

5.3 Switching on the central heating

The central heating flow temperature is adjustable between 35°C and 88°C. Refer to table 12, page 26.

- ▶ Turn the temperature control  to set the flow temperature to a level appropriate to the type of central heating system:
 - Underfloor heating: e.g. setting “3” (approx. 50°C)
 - Low-temperature heating: setting “E” (approx. 75°C)
 - Central heating systems for flow temperatures up to 88°C: limited “max” setting for low-temperature operation (see page 26).

When the burner is alight, the **red** indicator lamp lights up.

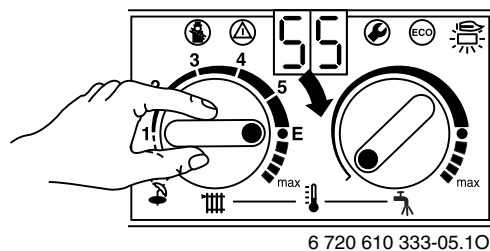

Fig. 31

5.4 System controls

- ▶ Set room thermostat to the desired room temperature.
- ▶ Set outside - temperature driven control unit, if fitted. Refer to the instructions with the control.
- ▶ Set the thermostatic radiator valves to the desired settings.

5.5 Setting the domestic hot water temperature and flow rate

5.5.1 Domestic hot water temperature

The hot water temperature can be set to between approx. 40 °C and 60 °C.

This temperature is not shown on the display.

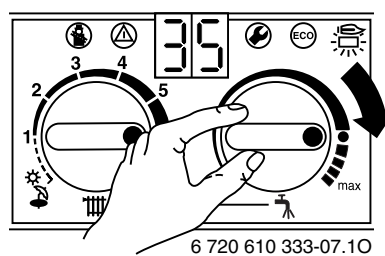

Fig. 32

Setting	Hot Water temperature
Turn fully anti-clockwise	approx. 40°C
●	approx. 55°C
Turn fully clockwise	approx. 60°C

Table 10

“ECO” button

By pressing and holding the “ECO” button (ECO) until the display lights, you can switch between **Comfort mode** and **Economy mode**.

Comfort mode: button is not lit (factory setting)

The appliance is held constantly at the set temperature. This means that hot water is available almost instantaneously at the tap. Consequently the appliance will switch on at intervals, even if no hot water is being drawn.

ECO mode with demand detection, button is lit

The demand detection function enables maximum gas and water economy.

Briefly turning a hot water tap on and then off again signals demand to the appliance which then heats up the water to the set temperature.

Hot water is thus available in about 1 minute.

ECO mode, button is lit

Water is not heated up until hot water is drawn. This means that there is a longer waiting period before hot water is available.

5.5.2 Hot water flow rate

The flow rate is factory set to 8 l/min.

Under standard conditions (2 bar) supply pressure, one full turn is equivalent to approximately 2 l/min.

- ▶ **To increase the flow rate (max. 14 l/min):**
turn screw on flow switch anti-clockwise (+).
The outlet temperature will decrease relative to the increase in the flow rate.
- ▶ **To reduce the flow rate (min. 8 l/min):**
turn screw on flow switch clockwise (-).
The outlet temperature will increase relative to the decrease in the flow rate.

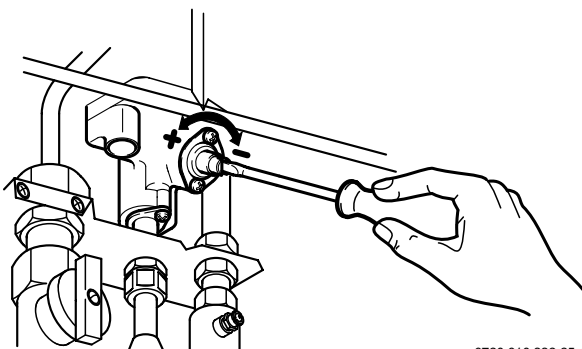

6720 610 332-25.10

Fig. 33

5.6 Summer mode (hot water only)

With room thermostat

- ▶ Turn temperature control IIII on the appliance anti-clockwise as far as the stop.

The central heating is now turned off. The hot water function and the mains power supply for the heating programmer and timer remain switched on.

5.7 Frost protection

- ▶ Leave master switch switched on.

If the appliance is to be left for long periods switch the central heating off:

- ▶ Add a suitable anti-freeze fluid to the water in the central heating system.
Suitable products are available from Betz-Dearbon Tel.: 0151 4209563 and Fernox Tel.: 01799 550811.

5.8 Pump anti-seize function



This function prevents the central heating pump seizing after long periods of inactivity.

Every time the pump is switched off, a timer is started. If after 24 hours the pump has not run again, it is switched on for a period of 5 minutes.

5.9 Fault Condition



A list of faults that may occur is given on page 43.

In the unlikely event of a fault occurring while the appliance is in operation:

The display then shows a fault code and the button (⚠) may also flash.

If the button (⚠) flashes:

- ▶ Press and hold the button (⚠) until the display shows “_ _”.

The appliance will then start up again and the display will show the central heating flow temperature.

If the button (⚠) does not flash:

- ▶ Switch the appliance off and then on again at the master switch.
The appliance will start up again and the central heating flow temperature will be displayed.

6 Individual settings

6.1 Mechanical settings

6.1.1 Checking the size of the expansion vessel

Maximum pressure at maximum CH flow temperature is 2.5 bar. If the pressure is greater than this then fit an extra expansion vessel. Refer to table 11.

System Capacity - BS7074:1

Expansion Vessel Pressure and System Capacity			
Expansion Vessel		litres	10
Expansion Vessel Charge Pressure		bar	0.75
System pressure and capacity	1 bar	litres	82
	1.5 bar	litres	46

Table 11

6.1.2 Setting the central heating flow temperature

The central heating flow temperature can be set to between 35°C and 88°C.

i With underfloor heating systems, observe the maximum permissible flow temperatures.

Limited maximum setting for low-temperature operation

The temperature control is factory limited to setting E, giving a maximum flow temperature of 75°C.

Adjustment of the heating output to the calculated heat demand is not required by the heating systems regulations.

Removing the maximum setting limit

For heating systems which require higher flow temperatures, the maximum setting limit can be removed.

- ▶ Lift off the yellow button on the temperature control  with a screwdriver.

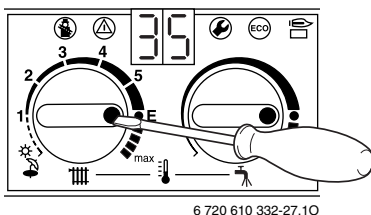

Fig. 34

- ▶ Rotate yellow button through 180° and replace (dot facing inwards).
The CH flow temperature is no longer limited.

Control setting	CH flow temperature
1	approx. 35°C
2	approx. 43°C
3	approx. 51°C
4	approx. 59°C
5	approx. 67°C
E	approx. 75°C
max	approx. 88°C

Table 12

6.1.3 Changing the heating pump characteristic

The speed of the central heating pump can be altered on the pump terminal box.

i At switch position 1, maximum output is not delivered if hot water mode is active. Position 1 must not be used on combi appliances.

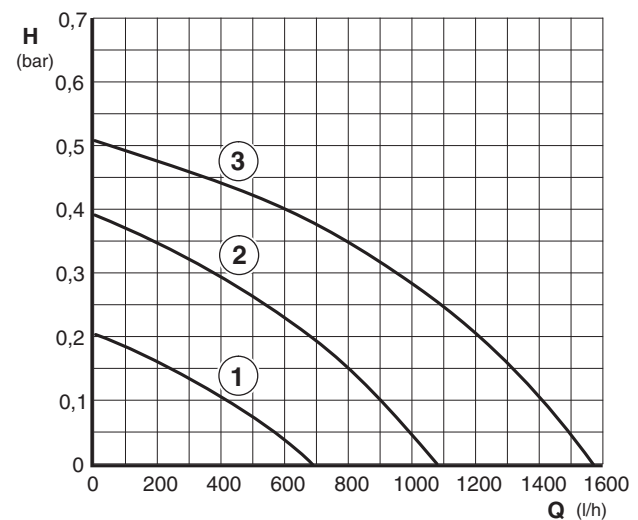

Fig. 35

- 1 Pump characteristic for switch position 1
- 2 Pump characteristic for switch position 2
- 3 Pump characteristic for switch position 3
- H Residual delivery pressure
- Q Water circulation rate

6.2 Settings on the Bosch Heatronic

6.2.1 Operating the Bosch Heatronic

The Bosch Heatronic enables easy setting and checking of a large number of appliance functions.

This description is limited to those functions required for commissioning.

For a full description of all available functions, please refer to the Service booklet for the Engineer, number 7 181 465 346.

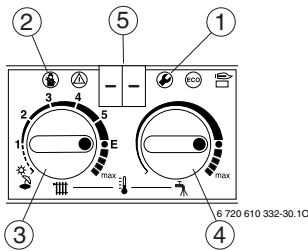

Fig. 36 Appliance controls

- | | |
|---|-----------------------------------------|
| 1 | Service button |
| 2 | "Chimney sweep" button |
| 3 | Temperature control for central heating |
| 4 | Temperature control for hot water |
| 5 | Display |

Selecting service function:

i Note the positions of the temperature controls and . After completing the settings, return the temperature controls to their original positions.

The service functions are subdivided into two levels: **Level 1** comprises service functions up to function **4.9**, while **Level 2** consists of the service functions from **5.0** upwards.

- ▶ To select a service function on Level 1: press and hold the button until the display shows --.
- ▶ To select a service function on Level 2: press and hold the buttons and simultaneously until the display shows ==.
- ▶ Then turn the temperature control to select the required function.

Service function	Code no.	See page
Pump control mode	2.2	27
Anti-cycle time	2.4	27
Max. CH flow temperature	2.5	28
Switching difference	2.6	28
Max. heating output	5.0	28
Constant hot water cycle time	6.8	28

Table 13

The service function 5.0 may be reset.

Entering a setting

- ▶ To enter the setting for a function, turn the temperature control .

Storing a setting

- ▶ Level 1: press and hold the button until the display shows [].
- ▶ Level 2: press and hold the and buttons simultaneously until the display shows [].

After completing the settings

- ▶ Reset the temperature controls and to their original positions.

6.2.2 Selecting the pump control mode for central heating mode (Service Function 2.2)

i If an outside temperature driven control unit is connected, pump control mode 3 is automatically activated

The choice of settings is as follows:

- **Control Mode 1**
For heating equipment without a control unit.
The pump is controlled by the central heating flow temperature control.
- **Control Mode 2 (factory setting)**
For heating systems with room thermostat.
The central heating flow temperature control controls only the gas, the pump is not affected. The room thermostat controls both the gas and the pump.
The pump and fan have an overrun time of between 15 s and 3 min.
- **Control Mode 3**
The pump is controlled by the outside temperature driven control unit. In summer mode, the pump operates only for hot water mode.

6.2.3 Setting the anti-cycle time (Service Function 2.4)

This service function is only active if Service Function 2.7, automatic anti-cycle time, is deactivated.

The anti-cycle time can be set to between 0 and 15 minutes (is **factory set** to 3 minutes).

If the setting 0 is entered, the anti-cycle time is inactive.

The shortest possible anti-cycle time is 1 minute (recommended for single-pipe and hot-air heating systems).

i If the appliance is connected to an outside-temperature controlled heating programmer, the anti-cycle time does not need to be set on the appliance and is optimised by the programmer instead.

6.2.4 Setting the maxim CH flow temperature (Service Function 2.5)

The maximum CH flow temperature can be set to between 35°C and 88°C (factory setting).

6.2.5 Setting the switching difference (Service Function 2.6)



If the appliance is connected to an outside-temperature controlled programmer, the programmer sets the switching difference. It does not need to be set on the appliance.

The switching difference is the permissible divergence from the specified CH flow temperature. It can be set in increments of 1 K. The adjustment range is 1 to 30 K (is factory set to 0 K). The minimum CH flow temperature is 30°C.

6.2.6 Setting the heating output (Service Function 5.0)

The heating output can be set to any level between min. rated heat output and max rated heat output to limit it to the specific heat requirements.



The full rated heat output is still available for hot water or charging the hot water cylinder even if the heating output has been limited.

The factory setting is the max. rated heat output.

- ▶ Press and hold the and buttons simultaneously until the display shows ==. The and buttons will light up.

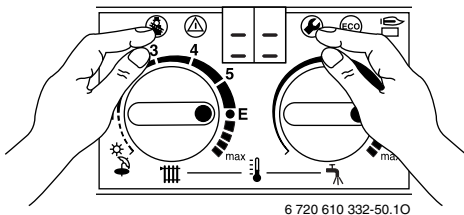

Fig. 37

- ▶ Turn the temperature control until the display shows 5.0. After a short delay, the display then shows the set heating output in percent.

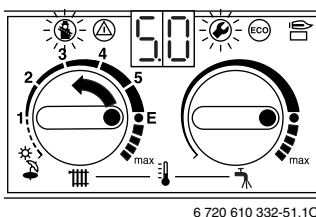

Fig. 38

- ▶ Refer to the settings tables for heating and cylinder charging output to obtain the relevant code for the desired heating output in kW (see page 45).
- ▶ Turn the temperature control until the display shows the desired code number. The display and the and buttons will flash.
- ▶ Measure the gas flow rate and compare with the figures specified for the code number displayed. If figures do not match, adjust the code number!
- ▶ Press and hold the and buttons simultaneously until the display shows []. The heating output is now stored.

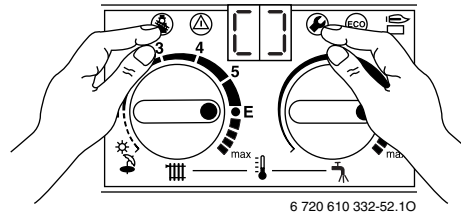

Fig. 39

- ▶ Return the temperature controls and to their original positions. The display will revert to the CH flow temperate.

6.2.7 Constant hot water cycle time (Service Function 6.8)

In Comfort mode “ECO light off”, the hot water inside the appliance is held constantly at the set temperature. For that reason, the appliance switches on if the water temperature falls below a certain temperature. In order to prevent it switching on and off too frequently, the constant hot water cycle time service function allows you to set the minimum period between switching off and on again. This function has no effect on normal demand for hot water and relates only to the constant hot water function in Comfort mode.

The cycle time can be set to any period between 20 and 60 minutes (is factory set to 20 minutes).

6.3 Setting the gas/air ratio

Refer to section 7.1 for details of the method of setting the gas/air ratio.

7 Converting the appliance to different gas types

The setting is factory sealed at maximum. Adjustment to the rated heat input and min. heat input is not necessary.

The gas/air ratio may only be adjusted on the basis of a CO₂ measurement at max. heat output and min. heat output using an electronic tester.

Checking the gas supply pressure

- ▶ Check the gas supply pressure at the gas supply pressure testing point.

i Natural gas appliances must not be operated if the gas supply pressure is below 18 mbar or above 24 mbar.
LPG appliances must not be operated if the supply pressure is not 37 mbar.

Natural gas

- Appliances for **natural gas type G20** are factory set to Wobbe-Index 15 kWh/m³ and 20 mbar supply pressure and sealed.

Conversion kits

Model	For conversion from ...	Order no.
ZWB 7-27 HE combi	N.G to L.P.G	7 710 149 044
ZWB 11-27 HE combi	L.P.G to N.G	7 710 239 080

Table 14

- Instructions are sent with each conversion kit.

7.1 Setting the gas/air ratio

- ▶ Switch off the appliance at the master switch (O).
- ▶ Remove the outer case (see page 15, refer to fig. 12).
- ▶ Switch on the appliance at the master switch (I).
- ▶ Unscrew sealing plug from flue gas testing point (234). Refer to fig. 40.
- ▶ Insert testing probe about 135 mm into the flue gas testing point and seal testing point.

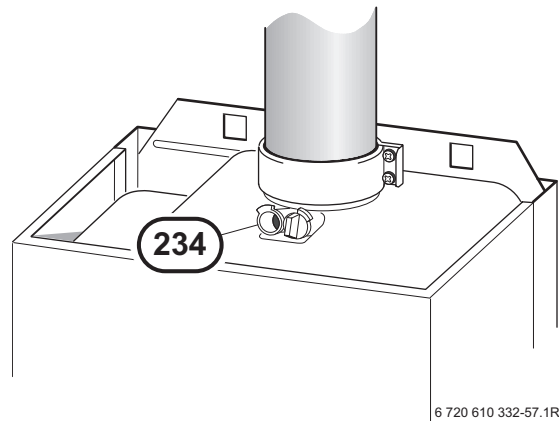



Fig. 40

- ▶ Press and hold  button until the display shows --. The  button will light up.

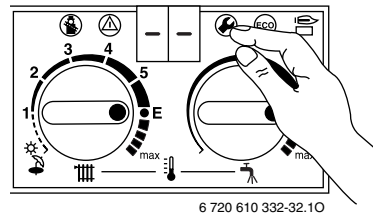



Fig. 41

- ▶ Turn the temperature control  until the display shows 2.0. After a short delay, the current operating mode setting will be displayed (0. = Normal mode).

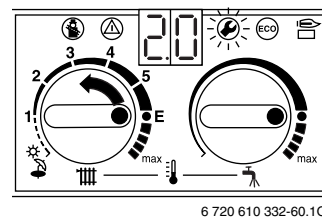

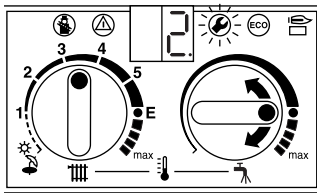

Fig. 42

- ▶ Turn the temperature control  until the display shows **2**. (= max. rated heat output). The display and the  button will flash.



6 720 610 332-61.10

Fig. 43

- ▶ Measure the CO₂ level.
- ▶ Prise off the seal on the gas flow restrictor.
- ▶ Adjust the gas flow restrictor (63) to obtain the CO₂ level given in Table 15. Refer to fig. 44.

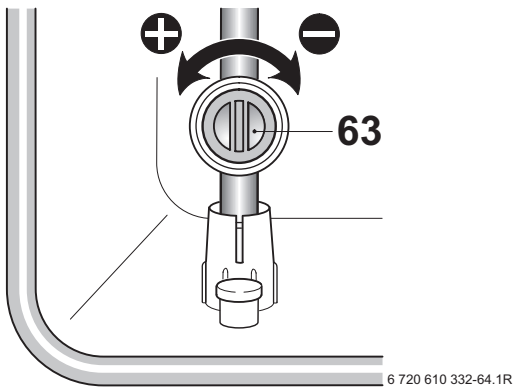



6 720 610 332-64.1R

Fig. 44

Gas Type	CO ₂ reading at max. rated heat output	CO ₂ reading at min. rated heat output
Natural gas type H (23)	9.5 %	9.2 %
LPG (propane)	11.3 %	11.0 %

Table 15

- ▶ Measure the CO level. If the CO level is over 300 ppm, the gas volumetric flow rate is too high. Reduce the gas flow rate on the adjustable gas flow restrictor (63) until the CO level is below 100 ppm.
- ▶ Re-adjust the CO₂ level if necessary.

- ▶ Turn the temperature control  anti-clockwise until the display shows **1**. (= min. rated heat output). The display and the  button will flash.

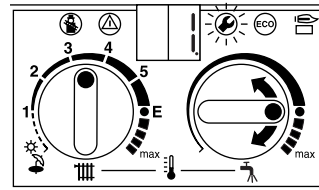

6 720 610 332-63.10



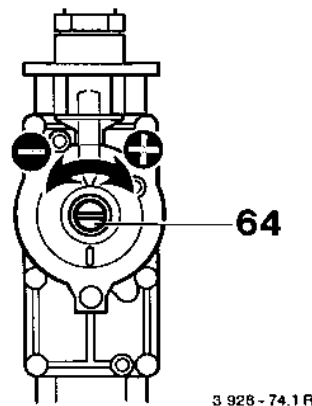

Fig. 45

- ▶ Measure the CO₂ level.
- ▶ Remove the seal from the gas valve adjusting screw (64) and adjust the CO₂ level to the figure given in Table 15 for min. rated heat output.



3 928 - 74.1 R

Fig. 46



- ▶ Measure the CO level. If the CO level is over 300 ppm, the gas volumetric flow rate is too high. Reduce the gas flow rate on the adjustable gas flow restrictor (63) until the CO level is below 100 ppm.
- ▶ Re-adjust the CO₂ level if necessary.
- ▶ Recheck the levels at min. and max. rated heat output and re-adjust if necessary.
- ▶ Turn the temperature control  anti-clockwise as far as the stop so that the display shows **0**. (= Normal operating mode). The display and the  button will flash.
- ▶ Press and hold the  button until the display shows [].
- ▶ Reset the temperature controls  and  to their original positions. The display will revert to the CH flow temperature.
- ▶ Remove testing probe from the flue gas testing point (234) and refit sealing plug.
- ▶ Re-seal gas valve adjusting screw and gas flow restrictor.
- ▶ Replace outer case and secure.

7.2 Testing combustion air/flue gas at set heat output

7.2.1 Testing the O₂ or CO₂ level in the combustion air



By testing the O₂ or CO₂ level in the combustion air the gas tightness of a type C₁₃ or C₃₃ **flue system** can be checked. The O₂ level must not be less than 20,6 %. The CO₂ level must not exceed 0,2 %.

- ▶ Press and hold the  button until the display shows --. "Chimney sweep" mode is now active. The  button will light up and the display shows the CH flow temperature.



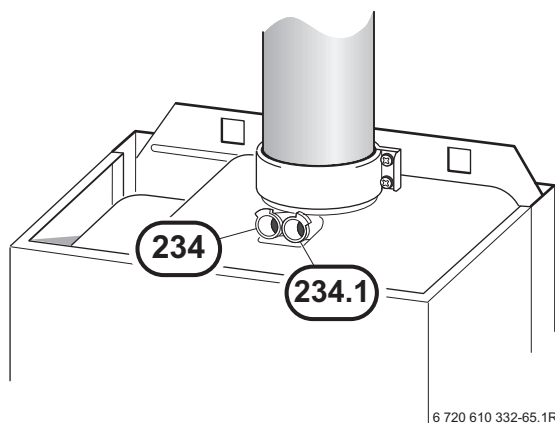

In "chimney sweep" mode, the appliance switches to max. rated heat output or the set heating output. You then have 15 minutes in which to measure the levels. After that, the appliance switches back from "chimney sweep" mode to normal mode.

- ▶ Remove sealing plug from combustion air testing point (234.1, fig. 47).
- ▶ Insert testing probe about 80 mm into the testing point and seal testing point.





6 720 610 332-65.1R

Fig. 47



- ▶ Measure O₂ and CO₂ levels.
- ▶ Refit sealing plug.
- ▶ Press and hold  button until the display shows --. The  button will stop flashing and the display shows the CH flow temperature.

7.2.2 Testing CO and CO₂

- ▶ Press and hold the  button until the display shows --. "Chimney sweep" mode is now active. The  button will light up and the display shows the CH flow temperature.



You have 15 minutes in which to measure the levels. After that, the appliance switches back from "chimney sweep" mode to normal mode.

- ▶ Remove sealing plug from flue gas testing point (234, fig. 47).
- ▶ Insert testing probe about 135 mm into the testing point and seal testing point.
- ▶ CO- and CO₂ levels.
- ▶ Refit sealing plug.
- ▶ Press and hold  button until the display shows --. The  button will stop flashing and the display shows the CH flow temperature.

8 Maintenance



- ▶ Always disconnect the appliance from the electrical power supply (fuse, circuit breaker) before carrying out any work on the electrical systems or components.



- ▶ Always turn off the gas cock before carrying out any work on components which carry gas.



There is a Service booklet for the Engineer, order no. 7 181 465 346, available to competent persons.



All safety and control systems are monitored by the Bosch Heatronic. In the event of a component fault, the display shows a fault code.

-
- ▶ The User should be recommended to have the appliance serviced regularly by a competent person (see Maintenance Contract).
 - ▶ Use only genuine spare parts
 - ▶ Refer to the Spare Parts List when ordering spare parts.
 - ▶ Always renew seals and O-rings removed during servicing or repair work.
 - ▶ Use only the following types of grease:
 - Water valve: WRc approved silicon based grease
 - Unions: approved sealant.
 - ▶ To drain the appliance shut the system valves and open the pressure relief valve.

8.1 Pre-Service Check List

		Date							
1	Call up the last fault stored by the Bosch Heatronic, Service Function .0, (see page 34).								
2	Check ionisation current, Service Function 3.3, (see page 34).								
3	Perform visual check of air/flue duct. Visual check of diaphragm for soiling and splits (see page 36).								
4	Check gas supply pressure (see page 29).	mbar							
5	Test combustion air/flue gas (see page 31).								
6	Check CO ₂ setting for min./max. (gas/air ratio) (see page 29).	min. % max. %							
7	Check gas and water systems for leaks (see page 16).								
8	On combi models, check hot water outlet temperature (see page 34).								
9	Check heat exchanger (see page 34).	mbar							
10	Check burner (see page 35).								
11	Clean condensation trap (see page 36).								
12	Check charge pressure of expansion vessel matches static head of heating system.	mbar							
13	Check central heating system pressure.	mbar							
14	Check electrical wiring for damage.								
15	Check heating programmer settings.								
16	Check appliances that are part of the heating system								

Table 16

8.2 Description of servicing operations

The combustion performance must be checked before and after any servicing work on the combustion and burner components. Refer to section 7.2.

Check "Last fault stored":

- ▶ Select Service Function .0 (see page 27 "Selecting service function").

There is a list of the fault codes in the Appendix (see page 43).

To delete "Last fault stored":

- ▶ Turn temperature control  anti-clockwise as far as the stop.
- ▶ Press and hold the  button until the display shows [].
The last fault stored has now been deleted.

Checking the ionisation current, Service Function 3.3

- ▶ Select Service Function 3.3 (see page 27 "Selecting service function").

If the display shows 2 or 3, the ionisation current is OK. If the display shows 0 or 1, the electrode assembly (32.1, page 6) must be cleaned or replaced.

Domestic hot water

If the flow rate is too slow:

- ▶ remove the domestic hot water heat exchanger and replace,

-or-

- ▶ descale with a descaling agent approved for use on stainless steel.
- ▶ Before removing the heat exchanger shut the inlet valve and drain the hot water circuit.
- ▶ Use new seals when replacing the heat exchanger.

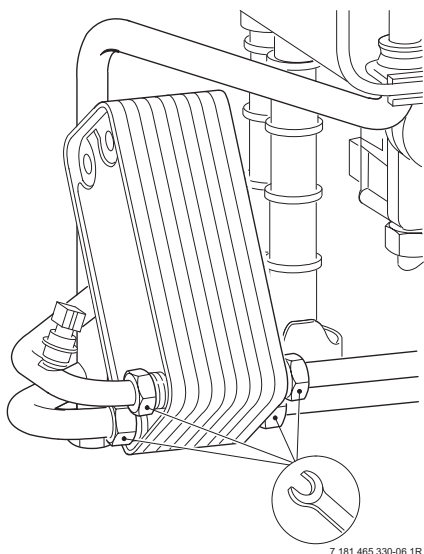

Fig. 48

Primary Heat exchanger

There is a special accessory kit (no. 840) for cleaning the heat exchanger, order no. 7 719 001 996.

- ▶ Check control pressure on the air - gas mixer unit at max. rated heat output using an electronic manometer.

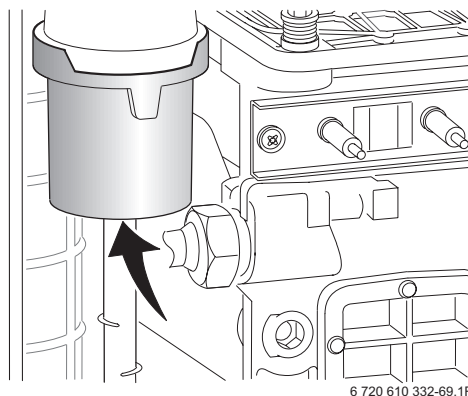

Fig. 49



The heat exchanger should only be cleaned if the control pressure is **2.2 mbar** (depression) or less.

- ▶ Remove cleaning access cover (415, page 6) and the metal plate below it, if present. Refer to fig. 2.
- ▶ Unscrew condensation trap and place suitable container underneath. Refer to fig. 50.
- ▶ Remove the fan and the burner as described in the text headed "Burner" (see page 35).

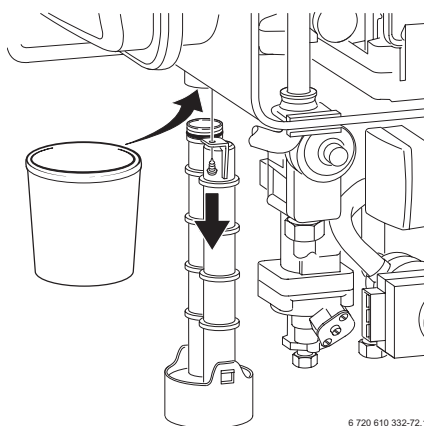

Fig. 50

- ▶ Loosen any deposits in the heat exchanger from top to bottom using the cleaning blade. Refer to fig. 51.

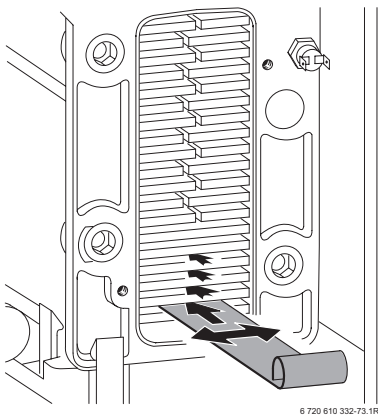

Fig. 51

- ▶ Clean the heat exchanger from top to bottom using the brush. Refer to fig. 52.

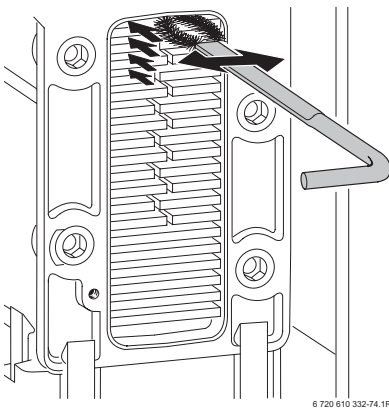

Fig. 52

- ▶ Remove the fan and the burner (see section headed "Burner") and flush the heat exchanger from the top.
- ▶ Clean out the condensate collector and trap connection (with other end of brush).

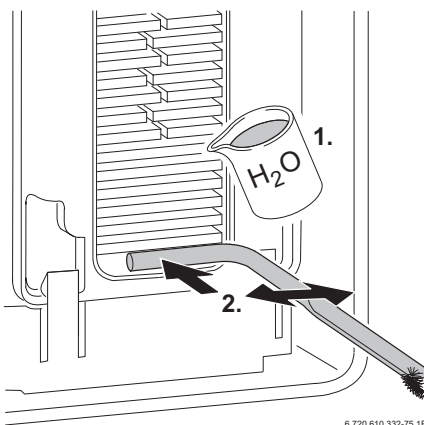

Fig. 53

- ▶ Refit the clean-out cover using a new seal and tighten screws to torque of approx. 5 Nm.

Burner

- ▶ Check that the gas cock is turned off and the master switch is in the OFF position.
- ▶ Remove the clips (1) and unscrew the two bolts (2). Refer to fig. 54.
- ▶ Unscrew and remove the two hexagon screws securing the fan (3).
- ▶ Slacken fully the rear securing bolt (4).
- ▶ Remove the burner coverplate.

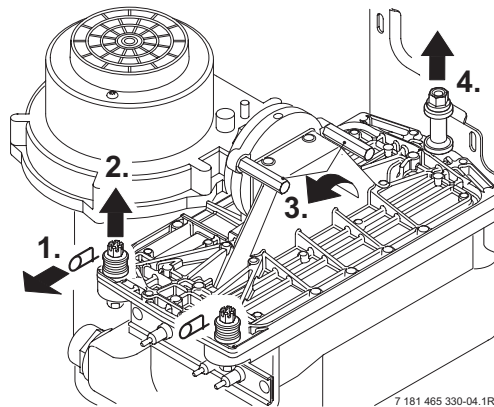

Fig. 54

- ▶ Remove burner and clean components. Do not use a wire brush. Refer to fig. 55.

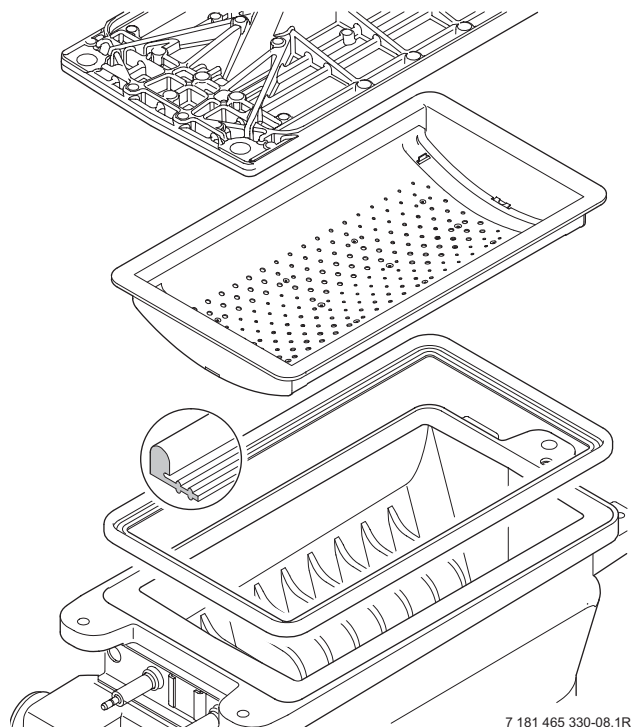

Fig. 55

- ▶ Re-assemble burner in reverse order using a new seal.
- ▶ Adjust gas/air ratio. Refer to section 7.2.

Diaphragm in mixer unit



- ▶ Take care not to damage diaphragm (443) when removing and refitting it.

- ▶ Open mixer unit (29).
- ▶ Carefully withdraw diaphragm (443) from fan intake tube and check for soiling and splits.

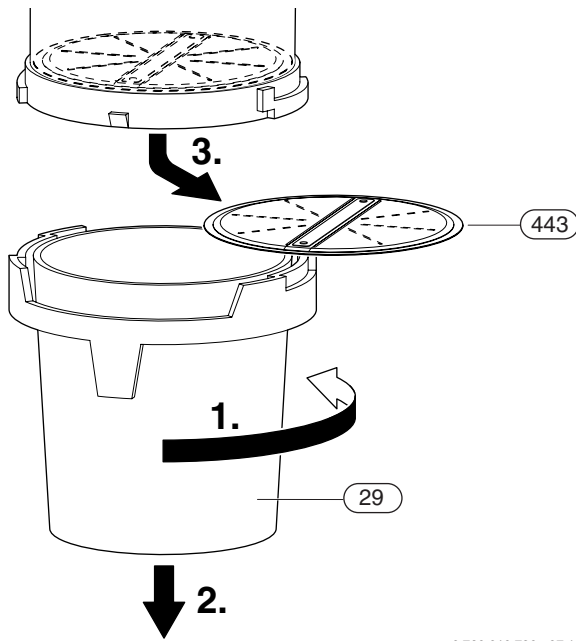

6 720 610 790 - 07.10

Fig. 56

- ▶ Carefully refit diaphragm (443) the correct way round into the fan intake tube.



The flaps of the diaphragm (443) must open upwards.

- ▶ Seal the mixer unit (29).

Condensation trap

In order to prevent spillage of condensate, the condensation trap should be completely removed, (see page 34, fig. 50).

- ▶ Unscrew condensation trap and check connection to heat exchanger is clear.
- ▶ Remove condensation trap cover and clean.
- ▶ Fill condensation trap with approx. 1/4 l of water and refit.

Electrode assembly

- ▶ Switch off the master switch.
- ▶ Pull off the leads from the electrodes. Refer to fig. 2.
- ▶ Unscrew the two fixing screws and carefully remove the electrode assembly. Refer to fig. 49.
- ▶ Clean the electrodes with a non-metallic brush. (The spark gap should be 4,5 mm ± 0,5 mm.)

- ▶ Replace and re-connect the assembly taking care not to mislay the inspection window.

Siphon

- ▶ Unscrew the clip and disconnect the pipe to the siphon.
- ▶ Remove the yellow plug to drain the siphon.
- ▶ Unscrew the securing nut from beneath the side facia and remove the siphon. Refer to figure below.
- ▶ Refit and prime the siphon.

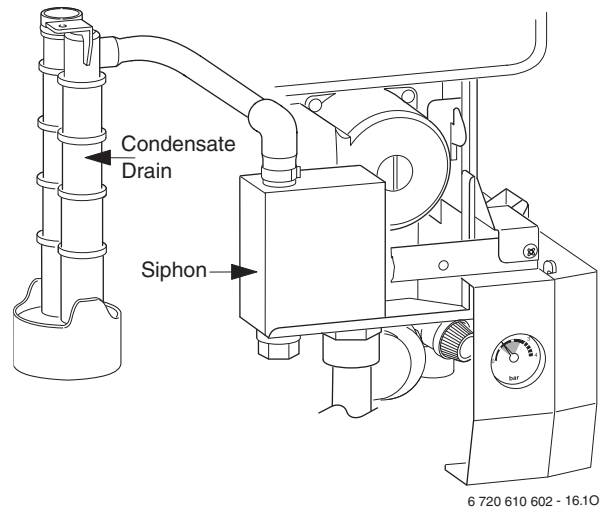

6 720 610 602 - 16.10

Fig. 57

Expansion vessel

The expansion vessel should be checked once a year.

- ▶ Depressurise appliance.
- ▶ If necessary, adjust expansion vessel charge pressure to static head of the heating system.

Heating system pressure



Fill the system using the WRc approved filling loop.

- ▶ The pointer on the pressure gauge should be 1 bar.
- ▶ If the pointer is below 1 bar (when the system is cold), water should be added until the pointer is 1 bar again.
- ▶ **Max. pressure** of 2.5 bar when the heating system water is at maximum temperature must not be exceeded. If this pressure is exceeded then an extra expansion vessel must be fitted in the system return as close to the appliance as possible.
- ▶ If the system does not retain the pressure, the expansion vessel and the heating system should be checked for leaks.

Electrical wiring

- ▶ Check the electrical wiring for physical damage and replace any damaged wires.

8.3 Replacement of Parts

Before changing any components check that the gas is turned off and that the appliance is electrically isolated. When necessary close the system valves and drain the appliance.

Refitting is a reverse of the procedure for removal using new seals or o-rings as appropriate.

8.3.1 PCB control board and transformer

- ▶ Switch off the appliance.
- ▶ Disconnect appliance from the power supply.
- ▶ Unplug all connectors from the control box (inc. keyed plug). Access is gained by removing the covers. Refer to fig. 24, 25.
- ▶ Remove screw holding power connector earth lead and remove earth lead.
- ▶ Remove two top fixing screws from the control box. Refer to fig. 58.

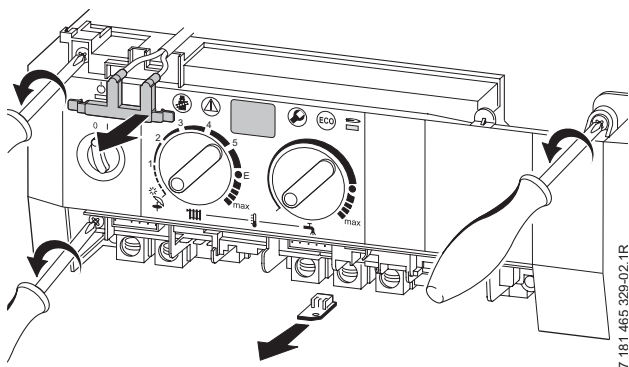

Fig. 58

- ▶ Lower the control box.
- ▶ Unscrew earth lead.
- ▶ Unscrew four fixing screws from cover plate. Refer to fig. 59.
- ▶ Prise off cover plate.
- ▶ Pull off transformer.
- ▶ Remove pcb holder.

- ▶ Remove the pcb control board.

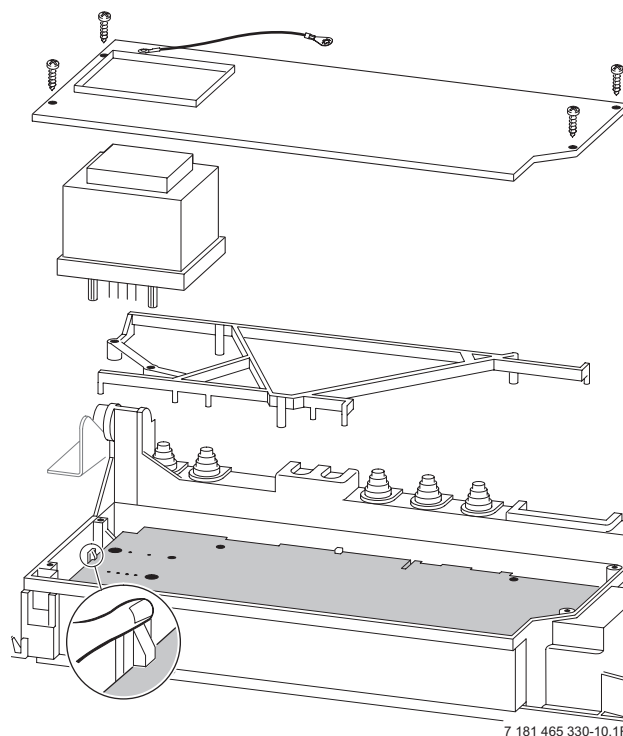

Fig. 59

Fuses

- ▶ Remove the connections covers. Refer to fig. 24, 25.

The fuses are located adjacent to the mains connector block and connector ST18. Refer to fig. 4.

Fuse, item 312, is only replaceable by removing the pcb.

Spare fuses are fixed to the connections cover.

A fuse pack is available: Part number 8 744 503 010 0.

8.3.2 Fan Assembly

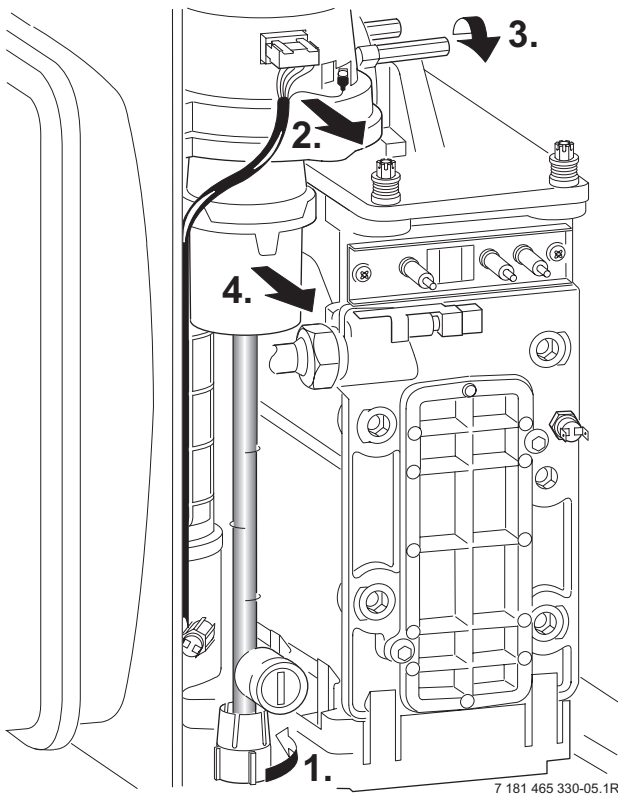

Fig. 60

- ▶ Switch off the appliance.
- ▶ Disconnect the appliance from the power supply.
- ▶ Undo lower pipe union on gas pipe (1.). Refer to fig. 60.
- ▶ Remove fan lead and earth connector (2.). The earth connector has a positive clip fixing.
- ▶ Remove fixing screws attaching fan to the burner cover (3.).
- ▶ Remove fan together with gas pipe and mixer unit.
- ▶ Separate the fan from the pipe and mixer unit by twisting the mixer unit to release it (4.).

8.3.3 Pump

- ▶ Switch off the appliance.
- ▶ Disconnect the appliance from the power supply.
- ▶ Remove two switchbox fixing screws (1.). Refer to fig. 61.
- ▶ Lower switchbox (2.).
- ▶ Unscrew and remove the the siphon by releasing the jubilee clip. Refer to fig. 57.
- ▶ Unscrew the pump union nuts (3.). Refer to fig. 61.
- ▶ Carefully remove the pump and disconnect the leads.

Alternatively

- ▶ After removing the siphon release the four Allen screws and remove and replace the pump head.

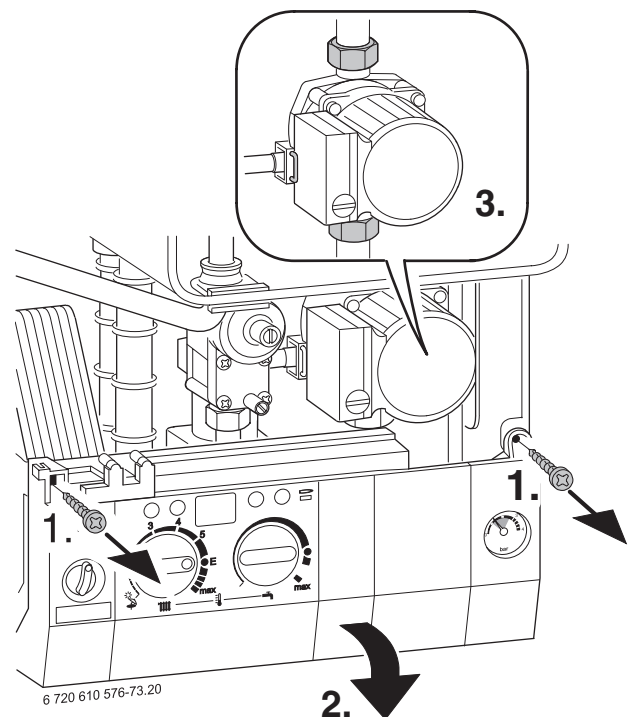

Fig. 61

8.3.4 3-way diverter valve

- ▶ Switch off the appliance.
- ▶ Disconnect appliance from the power supply.
- ▶ Turn off service cocks.
- ▶ Unplug connector from 3-way valve motor. Refer to fig. 62.
- ▶ Pull out retaining clip.
- ▶ Remove motor.
- ▶ Disconnect the relief valve drain.
- ▶ Disconnect the pressure gauge.
- ▶ Undo pipe unions.
- ▶ Remove 3-way valve.

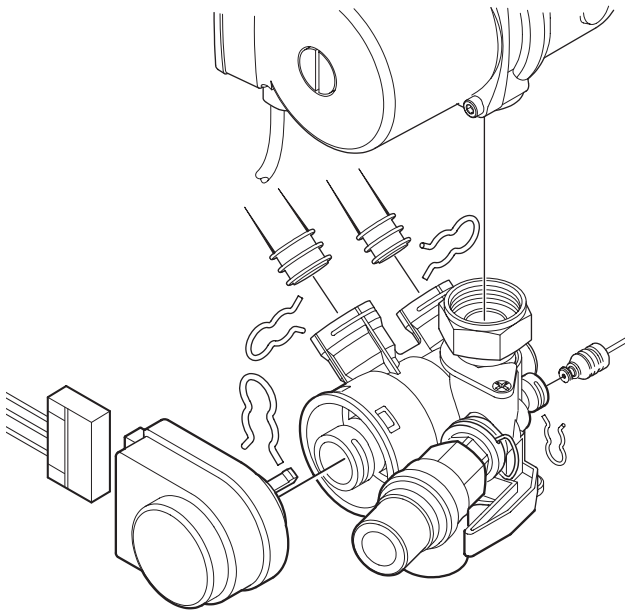

Fig. 62

After refitting:

- ▶ Fill system, bleed and re-pressurise (see Installation Instructions).

8.3.5 3-way diverter valve motor

- ▶ Switch off the appliance.
- ▶ Turn off the service cocks.
- ▶ Unplug connector from 3-way valve motor. Refer to fig. 62.
- ▶ Pull out retaining clip.
- ▶ Remove motor.

8.3.6 Sensors

- ▶ Check that the appliance is electrically isolated.

Central Heating Flow Temperature Sensor – Item 36, fig. 2, 58

- ▶ Pull-off the connector.
- ▶ Release the sensor clip and withdraw the sensor.
- ▶ Apply heat transfer paste to the replacement sensor.

Safety Temperature Limiter – Item 6, fig. 2, 58

- ▶ Pull-off the connectors.
- ▶ Unscrew the sensor.

Flue Temperature Limiter – Item 9, fig. 2, 58

- ▶ Pull-off the connectors.
- ▶ Unscrew the sensor.

Domestic Hot Water Temperature Sensor – Item 6.1, fig. 2

- ▶ Check that the inlet water valve is closed and the domestic hot water circuit is drained.
- ▶ Release and pull-off the connector.
- ▶ Unscrew the sensor.

8.3.7 Gas Valve

- ▶ Check that the gas cock is turned off.
- ▶ Lower the control panel. Refer to fig. 61.
- ▶ Pull off the solenoid connections at the rear of the valve.
- ▶ Undo the union, within the inner casing, securing the valve to the gas/air tube. Refer to fig. 60.
- ▶ Remove the white plastic cap from the gas valve.
- ▶ Release the gas inlet union at the manifold assembly.
- ▶ Unscrew the two screws securing the gas valve assembly bracket to the back panel and withdraw the assembly.
- ▶ Transfer the bracket and inlet pipe assembly to the new gas valve.
- ▶ Check for gas soundness when the new gas valve has been fitted.
- ▶ Recheck the combustion performance as described in section 7.1.

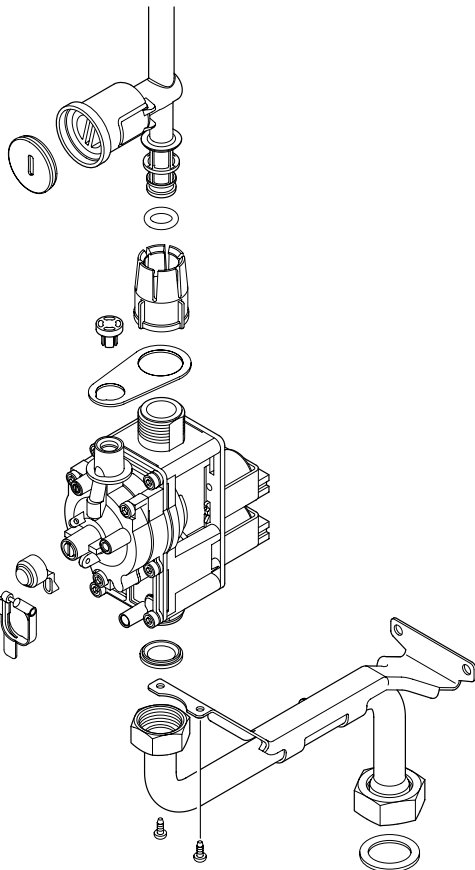

6 720 610 602 - 04.10

Fig. 63

8.3.8 Domestic Hot Water Heat Exchanger

- ▶ Refer to section 7.2.
- ▶ Use new seals when fitting the new heat exchanger.

8.3.9 Electrode assembly

- ▶ Refer to section 7.2.
- ▶ Use a new seal if the existing seal is damaged.

8.3.10 Pressure gauge

- ▶ Drain the appliance.
- ▶ Lower the facia. Refer to fig. 61.
- ▶ Twist the pressure gauge head anti-clockwise to release it from the casing. Refer to fig. 2.
- ▶ Disconnect the capillary head from the rear of the diverter valve by withdrawing the clip and pulling out the head. Refer to fig. 62.

8.3.11 Expansion vessel

- ▶ Drain the appliance.
- ▶ Undo the union connection at the base of the vessel. Refer to fig. 2.
- ▶ Unscrew the top and bottom fixing screws and remove the vessel.
- ▶ Set the pressure of the new vessel to that required by the system.

8.3.12 Pressure Relief Valve

- ▶ Drain the appliance.
- ▶ Disconnect the drain pipe from the valve. Refer to fig. 29.
- ▶ Pull-out the clip securing the valve.
- ▶ Pull-out the valve.
- ▶ Ensure that the replacement valve is fully entered before fitting the clip.

8.3.13 Burner

- ▶ Refer to section 8.2.

8.3.14 Flow switch

- ▶ Shut the mains water inlet valve and drain the domestic hot water circuit.
- ▶ Pull-off the connectors from the micro-switch.
- ▶ Unscrew the inlet and union connection and remove the assembly.
- ▶ Reset the domestic hot water flow rate on the new assembly.

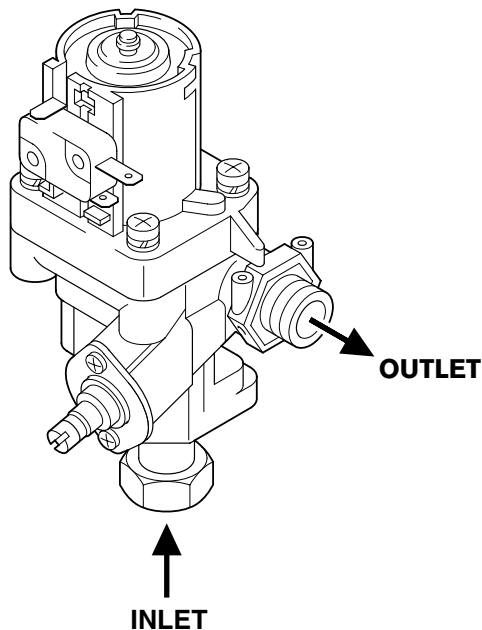

6 720 610 602 - 05.10

Fig. 64

8.3.15 Primary Heat Exchanger

- ▶ Drain the appliance.
- ▶ Check that the gas supply is turned off.
- ▶ Check that the appliance is electrically isolated.
- ▶ Remove the fan assembly complete with the gas/air tube and mixer assembly. Refer to section 8.3.2.
- ▶ Remove the burner. Refer to section 8.2.
- ▶ Disconnect the sensors. Refer to section 8.3.6.
- ▶ Undo the central heating flow union.
- ▶ Undo the top connection of the pump. Refer to fig. 61.
- ▶ Undo the grey plastic cap, next to the top pump connection at the base of the heat exchanger.
- ▶ Unscrew and remove the condensate trap. Refer to section 8.2.
- ▶ Unscrew and remove the two screws securing the heat exchanger top bracket to the rear panel.
- ▶ Lift up the flue duct, item 271, refer to fig. 2.

- ▶ Pull forward from the top and lift the heat exchanger from the casing.
- ▶ Transfer components, as necessary, to the new heat exchanger.
- ▶ Ensure that all the seals are in place and all of the connections are tight before re-commissioning the appliance.

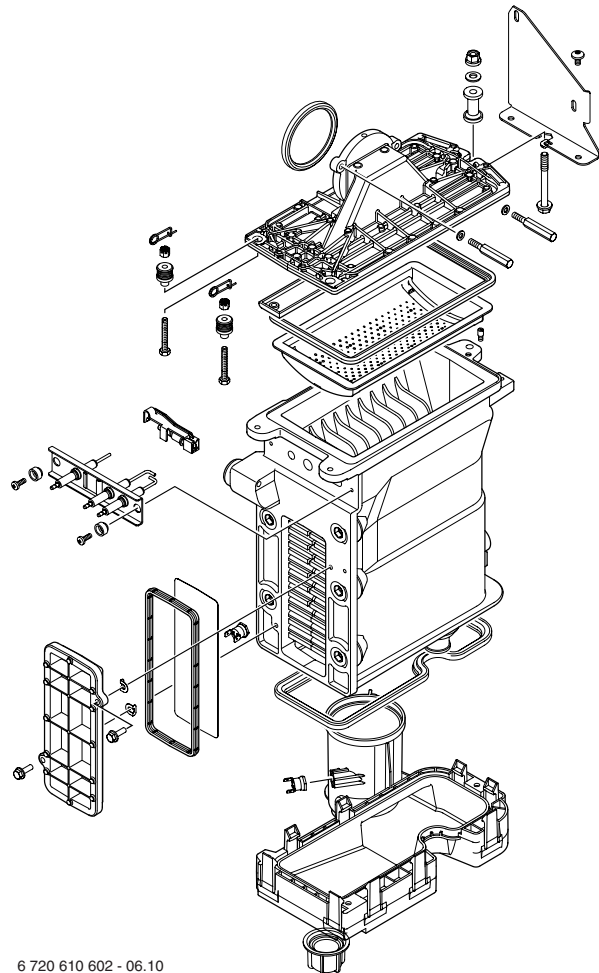

6 720 610 602 - 06.10

Fig. 65

9 Appendix

9.1 Fault Codes

More detailed fault finding procedures are described in the Service booklet for the Engineer number 7 181 465 346.

Display code	Description	Remedy
A7	Hot water NTC sensor defective.	Check hot water NTC sensor and connecting lead for circuit breaks/short circuits.
A8	Break in communication	Check connecting lead to programmer
AC	Module not detected.	Check connecting lead between TA211E/TR212E and Heatronic
b1	Keyed plug not detected.	Insert keyed plug correctly, test and replace if necessary.
C1	Fan speed too low.	Check fan lead and connector, and fan; replace as necessary.
d3	Jumper 8-9 not detected.	Connector not connected, link missing, underfloor heating limiter tripped.
E2	CH flow NTC sensor defective	Check CH flow NTC sensor and connecting lead.
E9	Safety temp. limiter in CH flow has tripped.	Check system pressure, check safety temp. limiters, check pump operation, check fuse on pcb, bleed appliance.
EA	Flame not detected.	Is gas cock turned on? Check gas supply pressure, power supply, igniter electrode and lead, ionisation sensing electrode and lead, flue duct and CO2 level.
F0	Internal error.	Check electrical connector contacts, programmer interface module ignition leads are not loose; replace pcb if necessary.
F7	Flame detected even though appliance switched off.	Check electrode assembly, dry pcb. Flue clear?
FA	Flame detected after gas shut off.	Check gas valve and wiring to gas valve. Clean condensation trap and check electrode assembly. Flue clear?
Fd	Reset button pressed by mistake.	Press reset button again
P1, P2, P3, P1...	Please wait, initialisation in progress.	24 V fuse blown. Replace fuse.

Table 17

9.2 Short parts list

Key	Description	Qty GC	Spare part number
1	Sensor - Flue gas temp.	1	8 729 000 144 0
2	Sensor - CH flow temp.	1	8 714 500 087 0
3	Sensor - DHW flow temp.	1	8 714 500 054 0
4	Control board	1	8 748 300 418 0
5	Gas valve	1	8 747 003 516 0
6	Fan assembly	1	8 717 204 373 0
7	Fan washer	1	8 729 000 183 0
8	Expansion vessel	1	8 715 407 236 0
9	Relief valve	1	8 717 401 012 0
10	Electrode assembly	1	8 718 107 077 0
11	Electrode lead	1	8 714 401 999 0
12	Pump	1	8 717 204 477 0
13	Pressure gauge	1	8 717 208 079 0
14	Burner skin seal	1	8 711 004 168 0
15	Transformer - facia	1	8 747 201 358 0
16	Flow switch	1	8 717 002 110 0
17	3-way diverter valve	1	8 717 010 062 0
18	Heat exchanger washer	1	8 710 103 153 0
19	Washerset Condensaion Trap	1	8 710 103 154 0
20	Fuseset	1	8 744 503 010 0
21	Serviceset Water Valve	1	8 710 503 031 0
22	Domestic Hot Water Heat Exchanger	1	8 715 406 659 0
23	Primary heat exchanger	1	8 715 406 615 0

Table 18

9.3 Heating/hot water output settings (N.G.)

Display code	Heat output kW	Heat input kW	Natural gas G20
			Gas vol. flow rate (l/min at $t_V/t_R = 80/60^\circ\text{C}$)
30	8.2	8.3	14.4
40	10.9	11.0	19.3
50	13.6	13.8	24.1
60	16.3	16.5	28.9
70	19.1	19.3	33.7
80	21.8	22.0	38.5
90	24.5	24.8	43.3
100	27.2	27.5	48.1

Table 19

9.4 Heating/hot water output settings (L.P.G)

Display code	Propane	
	Heat output kW	Heat input kW
40	10.9	11.0
50	13.6	13.8
60	16.3	16.5
70	19.1	19.3
80	21.8	22.0
90	24.5	24.8
100	27.2	27.5

Table 20

9.5 Operational Flow diagrams

9.5.1 Domestic hot water function

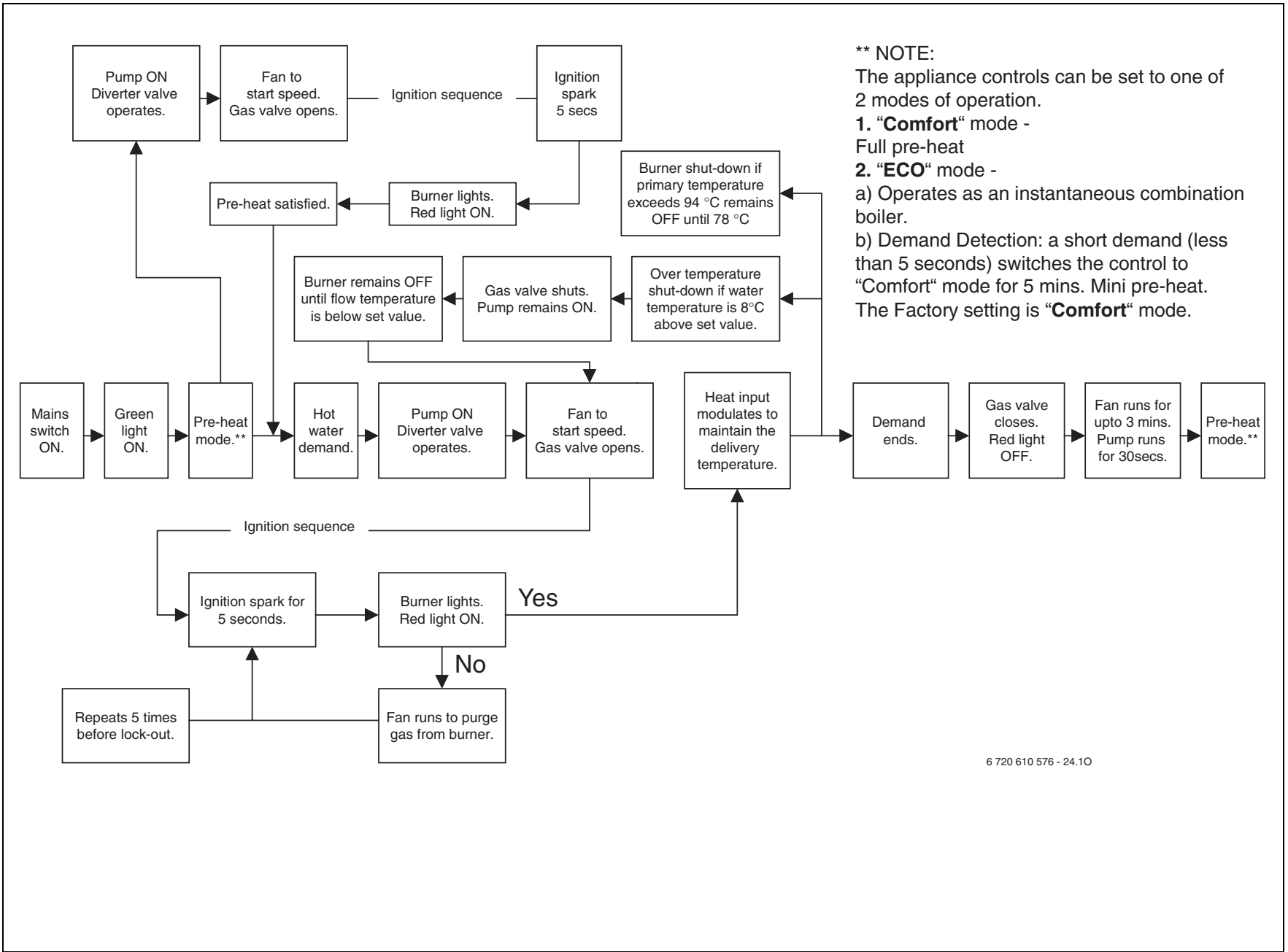

**** NOTE:**
 The appliance controls can be set to one of 2 modes of operation.
1. "Comfort" mode -
 Full pre-heat
2. "ECO" mode -
 a) Operates as an instantaneous combination boiler.
 b) Demand Detection: a short demand (less than 5 seconds) switches the control to "Comfort" mode for 5 mins. Mini pre-heat.
 The Factory setting is "Comfort" mode.

6 720 610 576 - 24.10

Fig. 66

Fig. 67

9.5.2 Central heating function

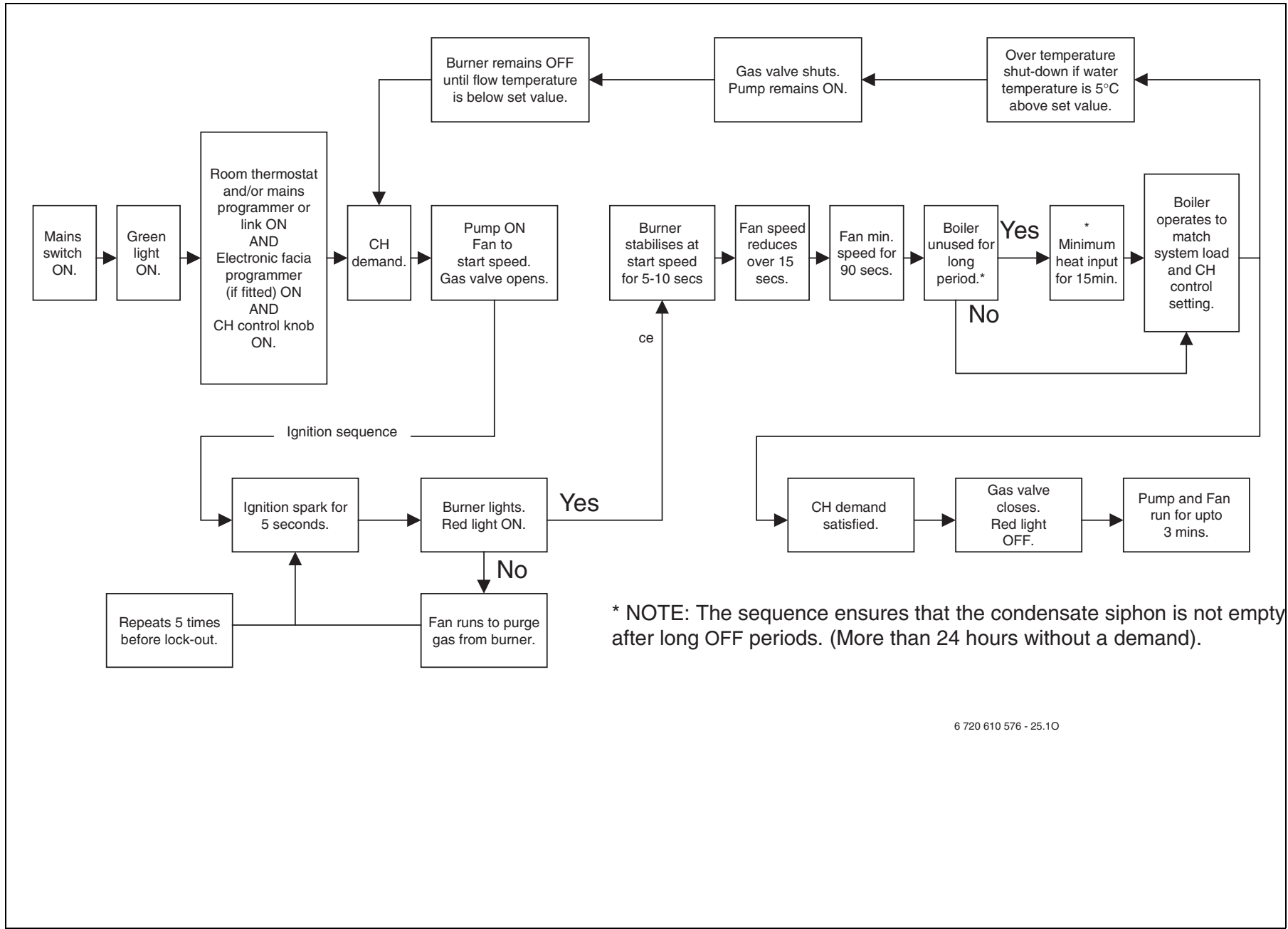

* NOTE: The sequence ensures that the condensate siphon is not empty after long OFF periods. (More than 24 hours without a demand).

EXCELLENCE COMES AS STANDARD

**Worcester Heat Systems Limited, Cotswold Way, Warndon, Worcester WR4 9SW.
Telephone: (01905) 754624 Fax: (01905) 754619**