

- 1 Ensure all system and boiler drain points are closed.
- 2 Remove the bottom panel (if fitted).
- 3 Ensure that the white plastic control screw (C) on the charging link is turned fully into its closed position.
- 4 Open the isolating valves on both the DHW inlet and CH return connections.
- 5 Insert the charging key (D) (situated in its storage position (E) on the bottom cover of the boiler) initially aligning the arrow on the key with the "unlock" symbol on the charging link body. Ensure that the key is inserted fully and turn to the "lock" position. Check that the key is secure.
- 6 To fill the system from the DHW inlet turn the white plastic control screw (C) on the charging link to the fully out position.
- 7 Once the system has been filled to a pressure of 1 bar turn the white control screw (C) to its closed position.
- 8 Vent all radiators, retighten when completed and check the system and correct any leaks.
 - The boiler integral expansion vessel is precharged to 0.75 bar (equal to a static head of 7.5 meters [22 ft]). A Schraeder type valve is fitted to the expansion vessel to allow for pressure adjustment if required.
 - If an extra expansion vessel is fitted to the central heating return, adjust to the **same pressure** as the appliance internal expansion tank, refer to separate instructions with the extra expansion vessel.
- 9 Briefly open the pressure relief valve to test its operation.
- 10 Refill the system up to 1 bar. Turn the white control screw (C) to its closed position and then remove the charging key by turning back to its "unlock" position and withdrawing.
- 11 Place the charging key (D) in its storage position (E) on the bottom cover of the boiler.

GAS SUPPLY

- ▶ Open gas cock on the boiler and purge the gas supply to the boiler ensuring that the room is well ventilated.
- ▶ Test gas supply for soundness as described in BS 6891.

IMPORTANT: Never run the appliance when the appliance/system is empty or partially filled.

SWITCHING THE APPLIANCE ON/OFF:

- 1 ▶ Turn on mains power supply.
▶ Turn on any external controls.
Set the thermostatic radiator controls to maximum temperature.
Set the clock/programmer to continuously ON and the room thermostat to maximum temperature.
 - 2 A - On/off button
B - On/off and fault indicator (BLUE)
C - Central heating temperature control
D - Burner indicator (GREEN)
E - Reset button
F - Service button
G - DHW temperature control
H - ECO button
I - System pressure gauge
J - Cover or optional programmer with intelligent functionality
K - Display
L - Central heating boost button
M - Holiday button
N - Automatic air vent
- ▶ Press button (A) and the power on indicator (B) illuminates BLUE. After a few seconds the display will show the flow temperature.

- 3 ▶ Turn the CH temperature control (C) to maximum. The burner on indicator (D) illuminates GREEN when the burner has lit.

NOTES:

- The first time the appliance is switched on, a once-only venting function is activated. The heating pump then switches on and off at intervals. This sequence lasts about 8 minutes. The display shows 0^0 in alternation with the CH flow temperature. The automatic air vent (N) must be open, please verify.
- The boiler runs for 15 minutes at minimum heating output to fill the condensate trap, the display (K) alternates between "H-" and the central heating flow temperature. This occurs every time the mains supply has been interrupted.

- 4 ▶ If the boiler fails to light the BLUE power indicator (B) and reset button (E) will flash alternately.
To reset press and hold the reset button (E) for 2 seconds. The boiler will be reset.

CAUTION: DO NOT PRESS POWER INDICATOR (B) TO RESET BOILER.

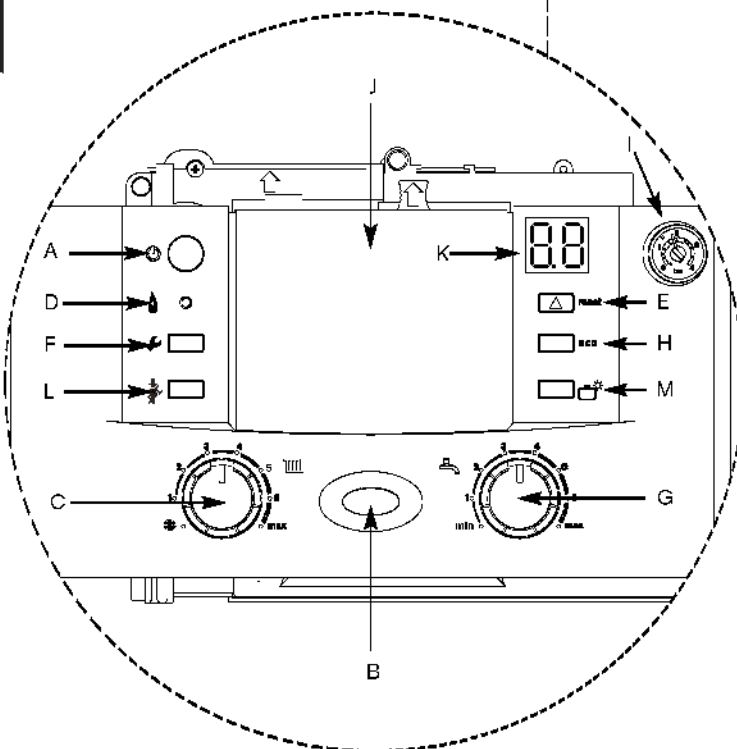
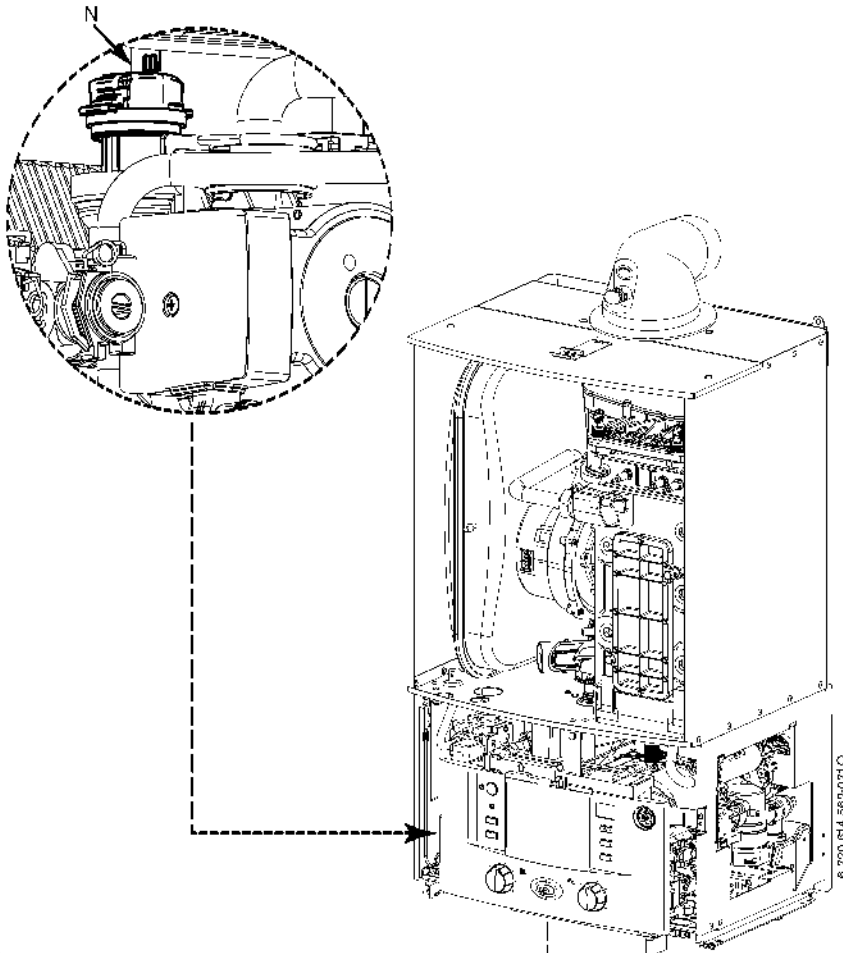

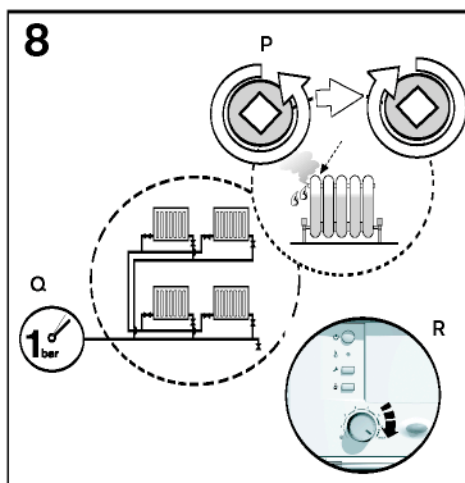
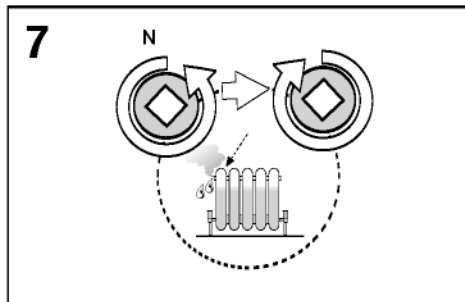
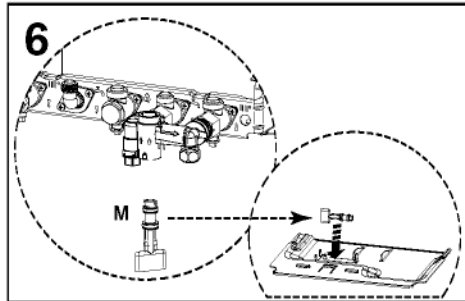
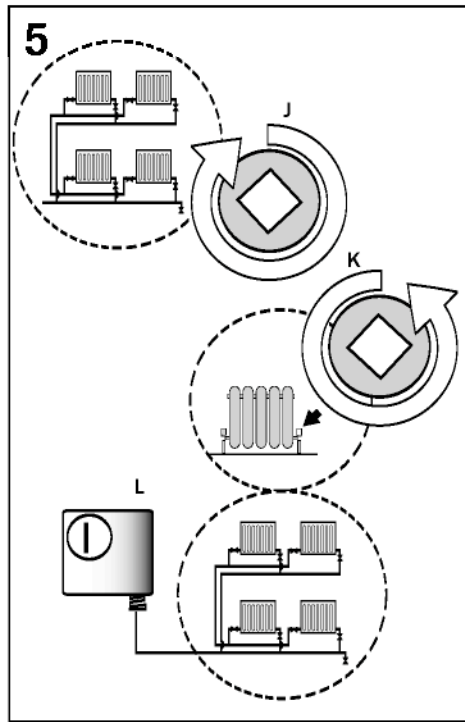
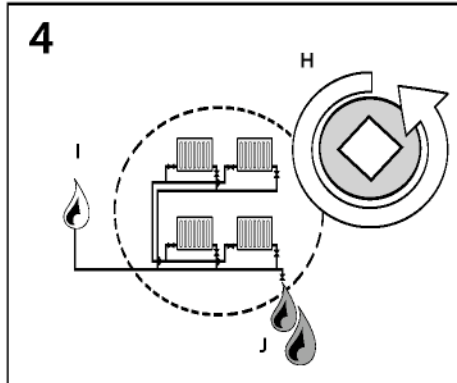
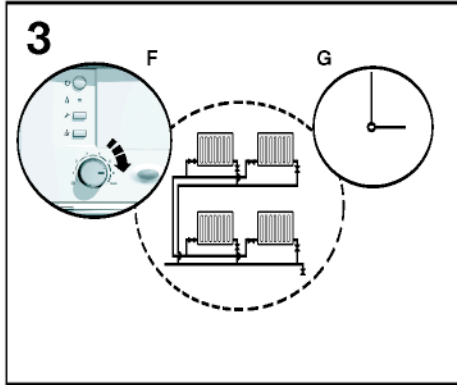
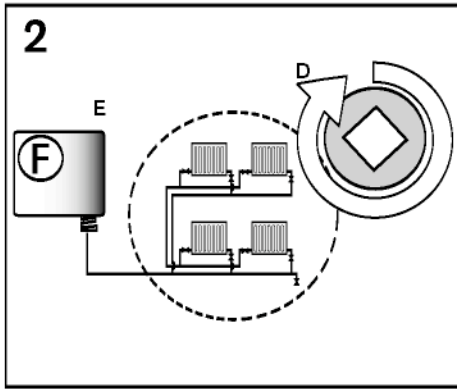
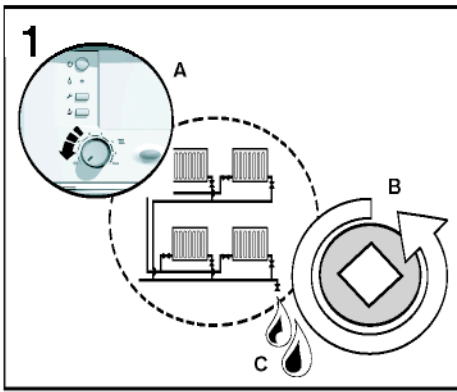

IMPORTANT: Debris from the system can damage the boiler and reduce efficiency. Failure to comply with the guidelines for the use of water treatment with the appliance will invalidate the appliance warranty.

ENSURE THAT THE SYSTEM HAS BEEN CLEANED AS ON PAGE 9 OF THESE INSTRUCTIONS.

FLUSHING (Central Heating):

1. ▶ Switch off the boiler (A).
▶ Open all drain cocks (B) and drain the system (C) while the appliance is hot.
2. ▶ Close drain cocks (D) and add a suitable flushing agent (E) at the correct strength for the system condition in accordance with the manufacturer's instructions.
3. ▶ Run the boiler/system at normal operating temperature (F) for the time stated by the manufacturer of the flushing agent (G).
4. ▶ Drain (H) and thoroughly flush the system to remove the flushing agent and debris (I).

INHIBITOR (Central Heating):

5. ▶ Check drain cocks are closed (J) and all radiator valves are open (K) before adding a suitable* inhibitor (or combined inhibitor/anti-freeze if the system is exposed to freezing conditions) to the heating system water (L) in accordance with the manufacturers instructions.
6. ▶ Fill via the built-in filling loop to between 1 and 2 bar using the filling key (M).
7. ▶ Vent all radiators; retighten vents when complete (N).
8. ▶ Re-pressurise if necessary to 1 bar (O).
▶ Set all controls to maximum (R).
▶ Record the date when the inhibitor was added to the system on the guarantee card.

NOTE: The concentration level of inhibitor in the system should be checked every 12 months or sooner if system content is lost.

The addition of sealing agents to the system water is not recommended as this can cause problems with deposits left in the heat exchanger.

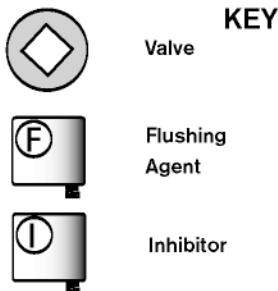

6 720 611 927-271 0

* compatible with aluminium. The pH value of the system water must be less than 8 or the appliance guarantee will be invalidated.

COMMISSIONING

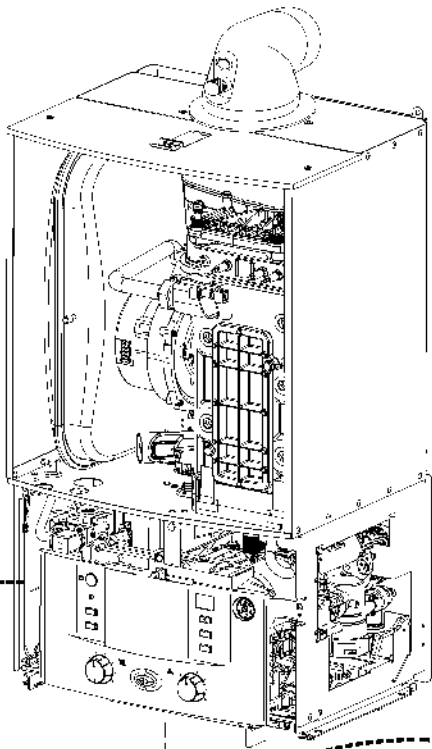

NOTE: When running in the central heating boost mode, the boiler will operate both the central heating and the domestic hot water circuits. This is to allow sufficient time for this part of the commissioning procedure. It will be necessary to run water through the domestic hot water circuit to ensure that the boiler will not cycle on low heating demands.

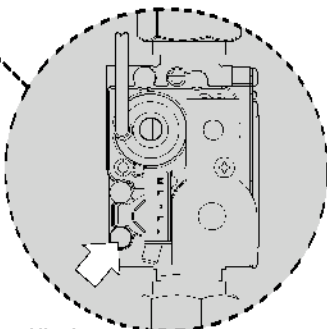
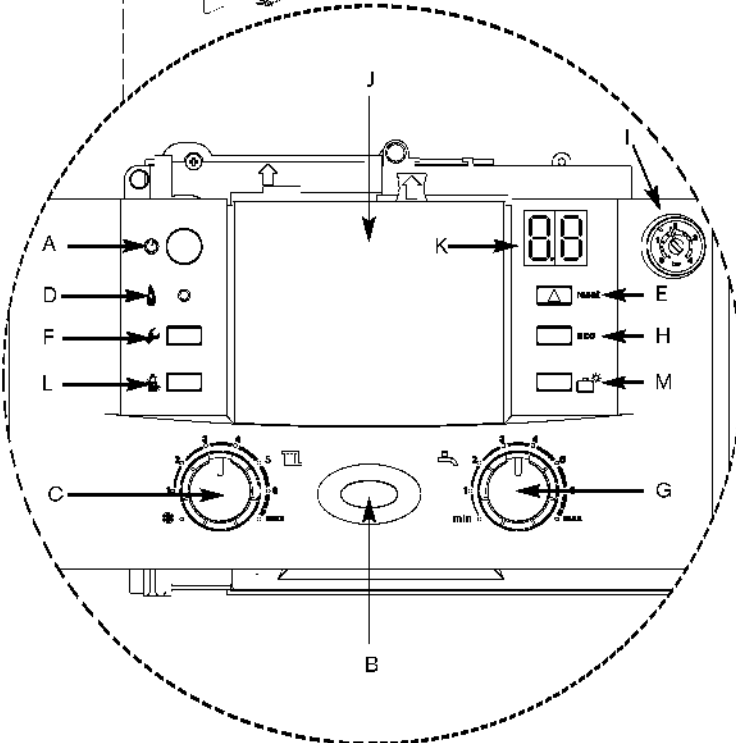

Inlet Test Nipple

- A - On/off button
- B - On/off and fault indicator (BLUE)
- C - Central heating temperature control
- D - Burner indicator (GREEN)
- E - Reset button
- F - Service button
- G - DHW temperature control
- H - ECO button
- I - System pressure gauge
- J - Cover or optional programmer with intelligent functionality
- K - Display
- L - Central heating boost button
- M - Holiday button

COMMISSIONING

THE COMBUSTION FOR THE APPLIANCE IS FACTORY SET.

NO ADJUSTMENT IS REQUIRED IF THE GAS INLET PRESSURE IS CORRECT.

CHECKING GAS INLET PRESSURE:

The inlet pressure to the appliance must be checked using the following procedure:

SETTING THE BOILER TO MAXIMUM:

- 1 ▶ Press central heating boost button (L) for ten seconds and set Central Heating temperature to maximum.
 - The central heating boost button will illuminate continually.

MEASURING THE INLET PRESSURE:

- 2 ▶ Slacken the screw in the inlet pressure test point and connect a manometer.
 - ▶ Measure the pressure with the boiler running at maximum.
 - ▶ Check the gas supply working pressure at the gas valve inlet point:
 - N.G. minimum 18 mbar
 - L.P.G. 37 mbar
 - ▶ The gas rate should be measured at the gas meter after 10 minutes operation at maximum. See technical data section at the front of this manual.
 - ▶ Ensure inlet pressure is satisfactory with all other gas appliances working.
 - ▶ Replace controls cover. **NOTE:** This boiler is designed with a differential of 20°C across the heating system.

IMPORTANT: Do not continue commissioning until the correct gas inlet pressure is achieved.

- ▶ If pressure is satisfactory press the central heating boost button (L) again and the boiler will return to normal operation.
- If left in the central heating boost mode the control will return to normal operation after 15 minutes.
- ▶ Re-seal the screw in the gas inlet pressure test point.

DOMESTIC HOT WATER:

Controlling the hot water temperature

- ▶ The hot water temperature can be set to between approximately 40°C and 60°C using the temperature control (G).

DOMESTIC HOT WATER PRE-HEAT:

Pre-heat reduces the time taken to produce hot water at the tap and is controlled by the ECO button (H).

- ▶ Press the ECO button to select either:

When the ECO button is **not illuminated** the boiler will be in pre-heat mode (which will reduce the time taken to produce hot water at the tap).

OR

When the ECO button is **illuminated** the boiler will be in Economy mode with pre-heat no longer active.

The boiler has been factory set, so there should be no need to adjust combustion settings.

REPLACE OUTER CASING:

- 1 Replace outer casing making sure that the securing points are properly located.
 - ▶ Press the clip (A) downwards to secure casing on top.
 - ▶ Retighten bottom two screws (B).

INSTALLING BOTTOM PANEL:

- 2 The bottom panel slides onto two ledges (C) either side of the boiler frame.
 - ▶ Hold the panel up against the underside of the boiler and slide towards the rear until it is fully engaged.

HANDOVER:

- ▶ Complete the Benchmark check list.
- ▶ Open the fascia cover by gently pressing the centre top of the cover (D).
- ▶ Set up the controls and show the user how to operate all the controls shown in the User Guide.
- ▶ Place the user guide into the tray (E) on the inside of the fascia cover.
- ▶ If the appliance is unused and exposed to freezing conditions; shut off all the mains supplies and drain the system and boiler.

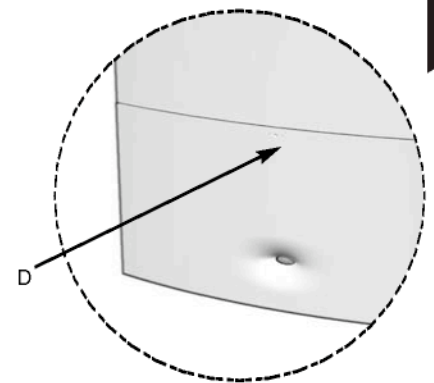
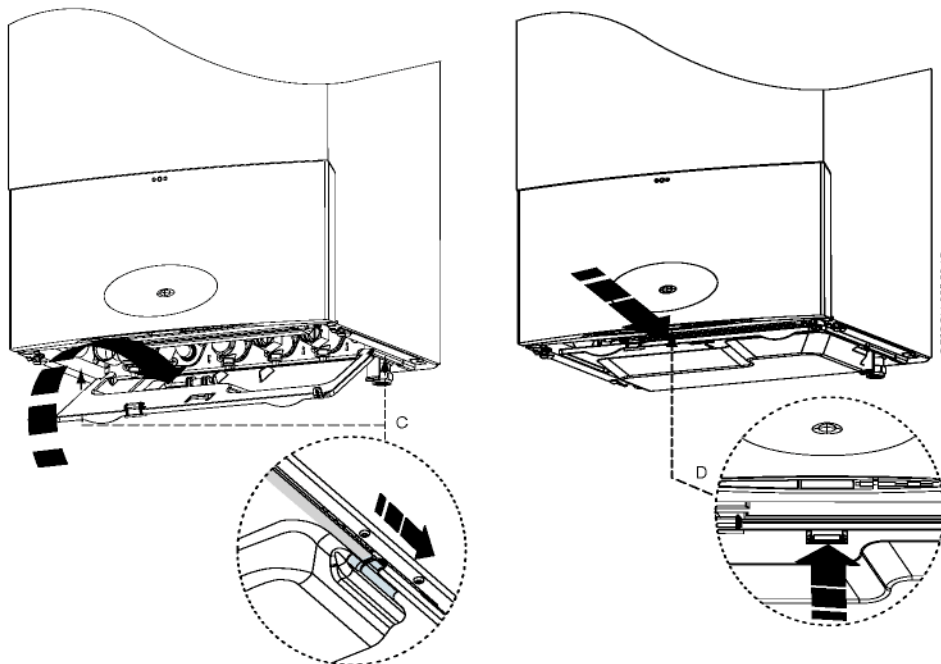
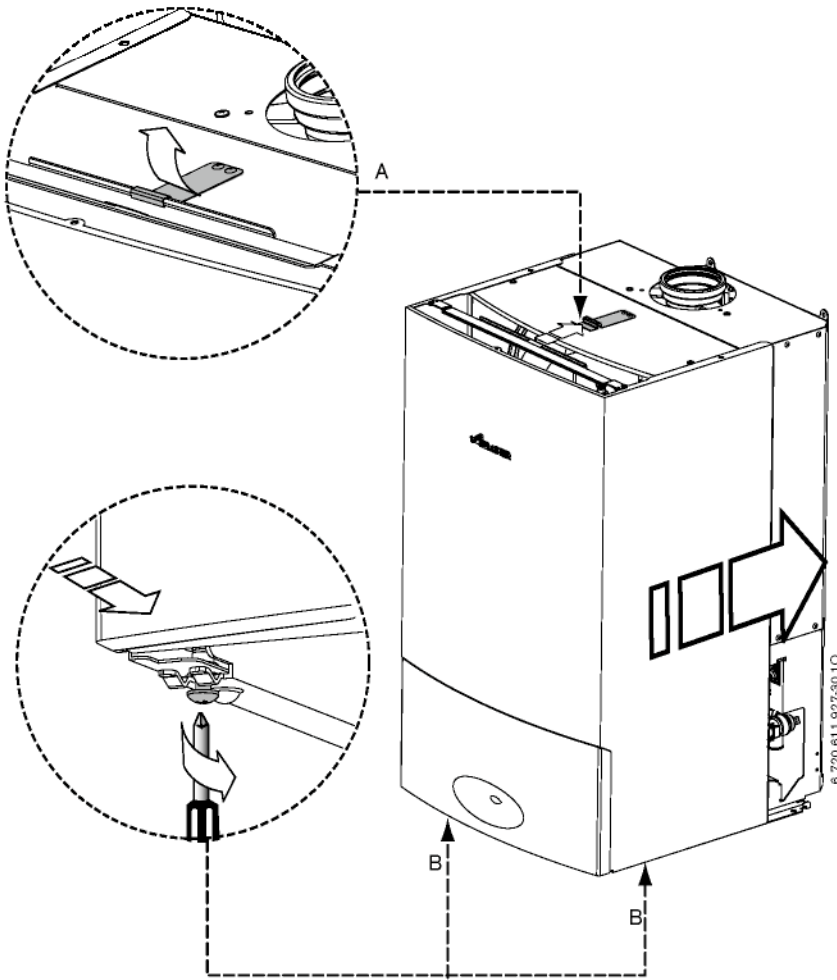

COMPONENT ACCESS

1. Removing outer case

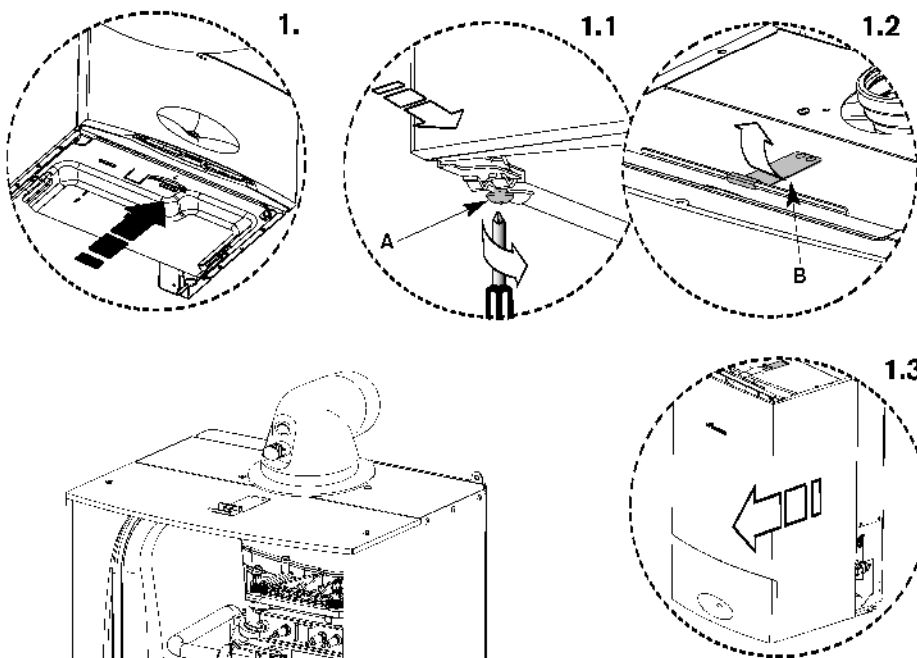

1. Remove bottom panel by pulling it forward and off.
- 1.1 Undo but do not remove the 2 screws (A) securing boiler casing at the bottom of the appliance.
- 1.2 Pull upwards to release the clip (B) on top of the boiler.
- 1.3 Pull case forward and remove.

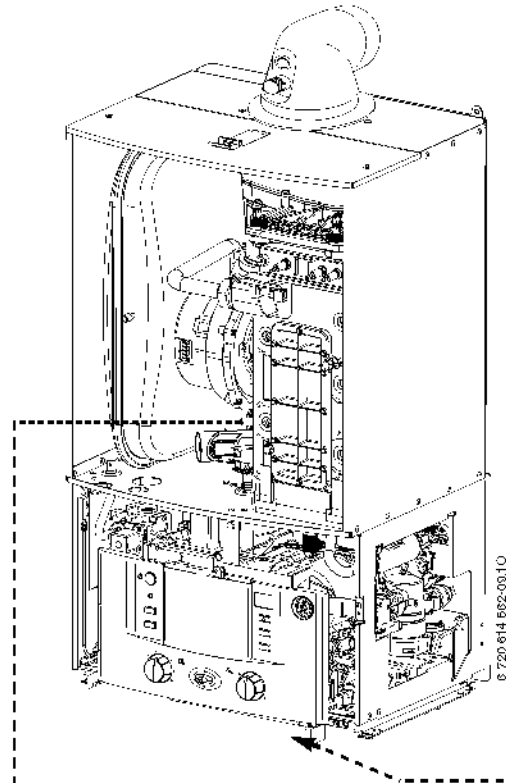

2. Adjusting boiler control to service position

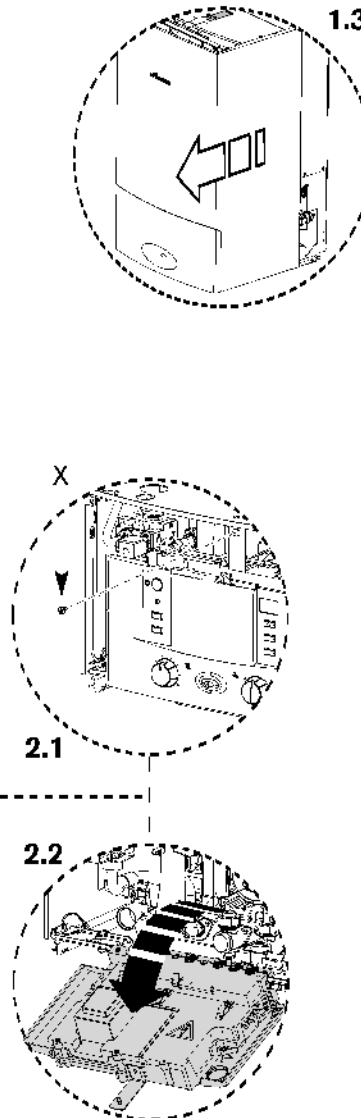

- 2.1 Remove screw (X) securing control.
- 2.2 Gently pull forward until it comes to rest in service position.

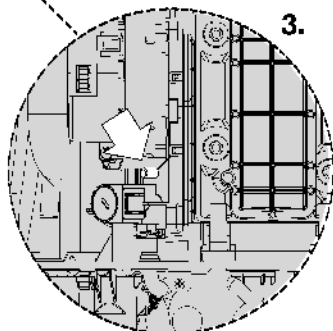

Primary Heat Exchanger

There is a special accessory kit available specifically designed for cleaning the heat exchanger. If required order 7 719 001 996.

3. ▶ Check fan pressure at the test point next to the fan using an electronic manometer
 - ▶ The boiler must be run at maximum output. Pressure will read negative and be greater than:

27CDi	- 3.0 mbar
30CDi	- 4.1 mbar
37CDi	- 3.9 mbar
42CDi	- 4.8 mbar

▶ Pressures measured below these figures will indicate that the heat exchanger will require cleaning.

Setting Boiler to Maximum.

NOTE: When running in the heating boost mode, the boiler will operate both the Central Heating and DHW circuits. This is to allow sufficient time for setting procedure.

It will be necessary to run water through the DHW circuit to ensure that the boiler will not cycle on low heating demands.

- A - On/off button
- B - On/off and fault indicator (BLUE)
- C - Central heating temperature control
- D - Burner indicator (GREEN)
- E - Reset button
- F - Service button
- G - DHW temperature control
- H - ECO button
- I - System pressure gauge
- J - Cover or optional programmer
- K - Display
- L - Central heating boost button
- M - Holiday button

- 1 ▶ Press and HOLD central heating boost button (L) for 10 seconds and set Central Heating temperature to maximum.
 - The central heating boost button will illuminate continually.
 - The boiler will stay in this mode for 15 minutes unless the central heating boost button is pressed again.
- 2 ▶ Pull the cover off and connect a manometer to the fan pressure test point.
 - ▶ After measurement replace test point cover.

Pressure will read negative and be greater than:

- 27CDi - 3.0 mbar
- 30CDi - 4.1 mbar
- 37CDi - 3.9 mbar
- 42CDi - 4.8 mbar

- Pressures measured below these figures will indicate that the heat exchanger will require cleaning.
- There is a special accessory kit available specifically designed for cleaning the heat exchanger. If required order 7 719 001 996.

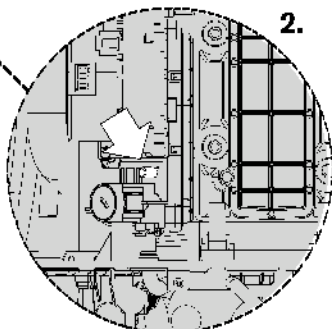
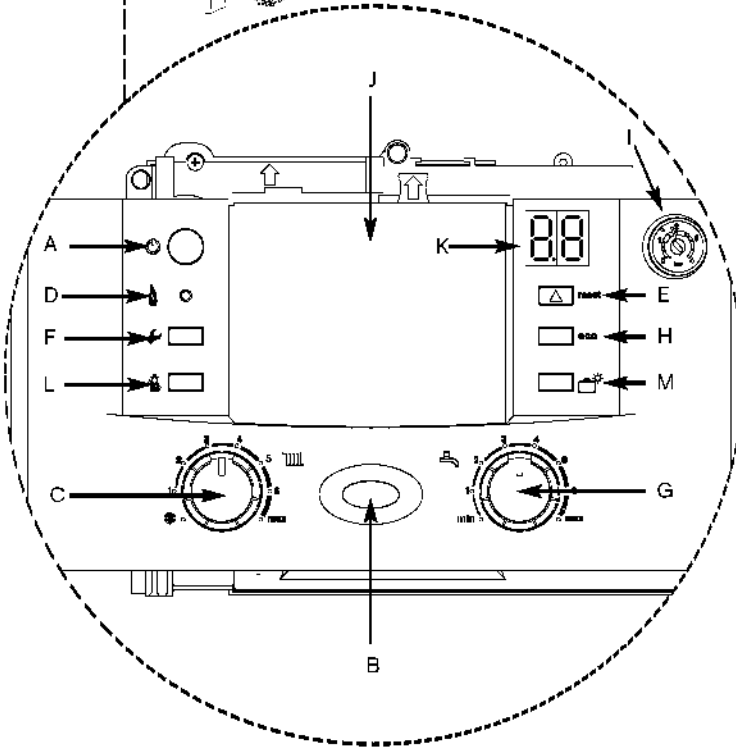
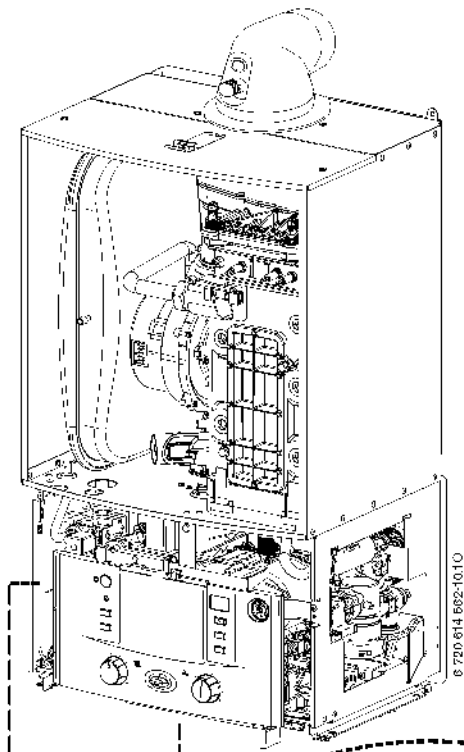

COMBUSTION TESTING MUST BE CARRIED OUT BY A COMPETENT PERSON. IT MUST **NOT** BE ATTEMPTED UNLESS THE PERSON CARRYING OUT THE COMBUSTION CHECK IS EQUIPPED WITH A COMBUSTION ANALYSER CONFORMING TO BS 7927 AND IS COMPETENT IN IT'S USE.

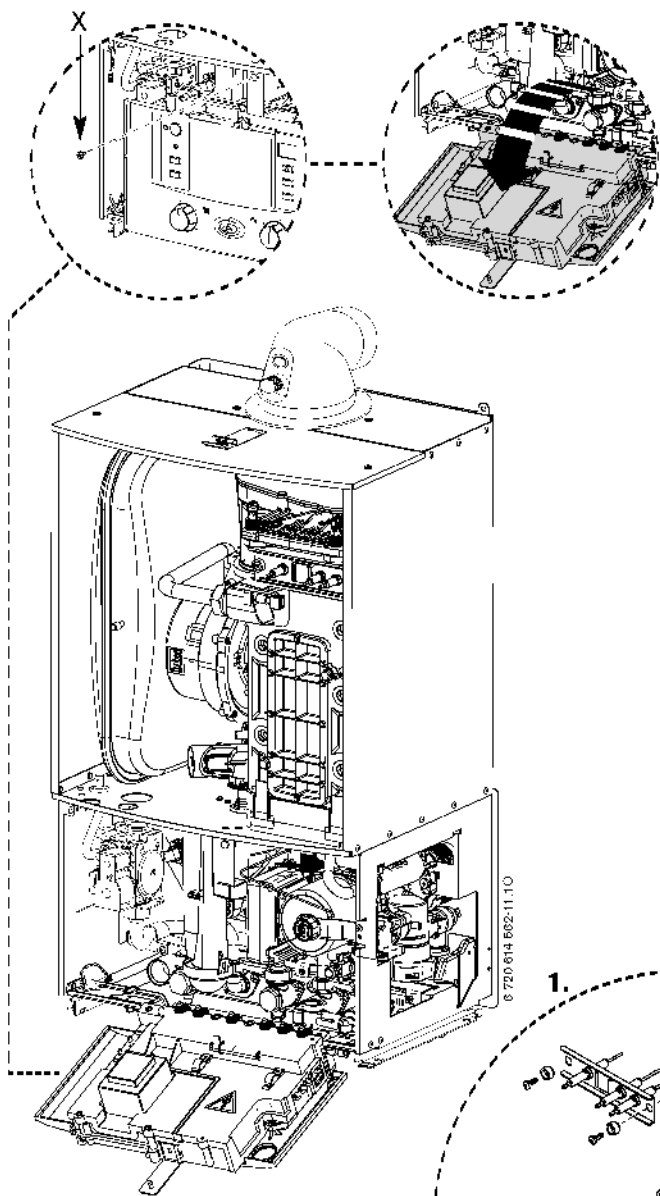

To Clean the Heat Exchanger

- ▶ Remove outer case and base panel and isolate the appliance from power.
- 1. ▶ Remove cleaning access cover (B), seal (C) and metal plate (D) securing it, if present.
- 2.1 ▶ Loosen any deposits in the heat exchanger from top to bottom using the cleaning blade.
- 2.2 ▶ Clean the heat exchanger from top to bottom using the brush.
- ▶ Refit the clean out coverplates in reverse order using a new seal (C) and tighten screws.

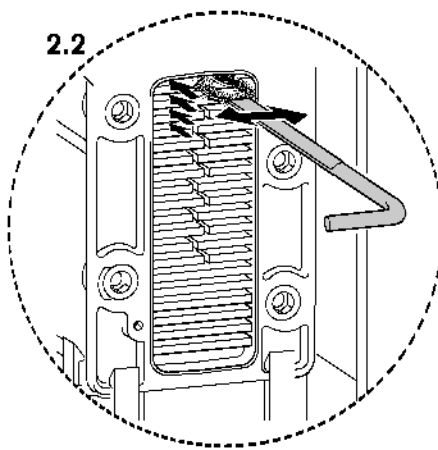
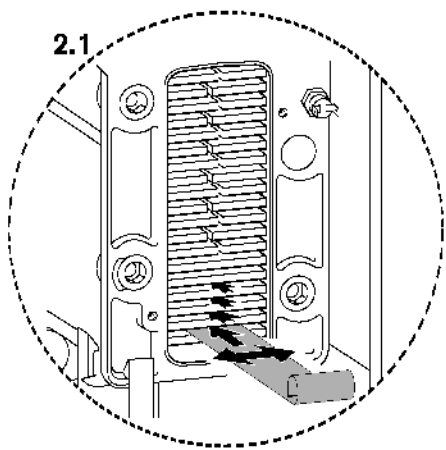
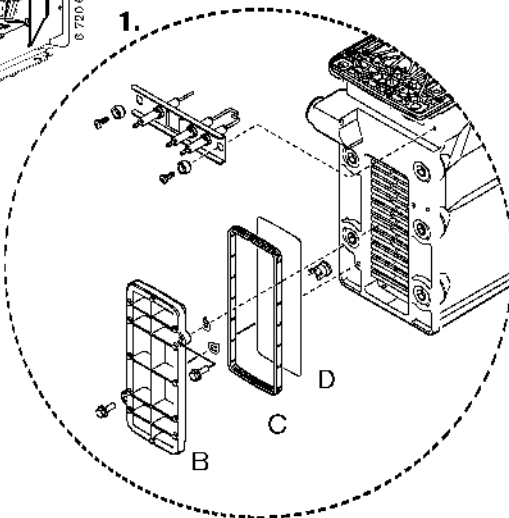

SERVICING & SPARES

To Clean the Burner

1. ▶ Remove cover panel (A) by removing the screws (B).
 - ▶ Check that the boiler is completely isolated from the gas supply.
2. ▶ Remove the clips (C) and unscrew the two bolts (D).
 - ▶ Unscrew and remove the two hexagon screws (E) securing the fan.
 - ▶ Slacken fully the rear securing bolt (F).
 - ▶ Remove the burner cover plate (G).
3. ▶ Remove the burner (H) and clean components. **Do not use a wire brush.**

To Check the Diaphragm in Burner Cover

4. ▶ Carefully withdraw diaphragm (J) from fan intake tube and check for soiling and splits.
 - ▶ Carefully refit diaphragm (J) the correct way round into the fan intake tube.

Note: The flaps of the diaphragm (J) must open upwards.

 - ▶ Re-assemble burner in reverse order using a new seal (K).
 - ▶ Adjust gas/air ratio. Refer to section "Setting the gas/air ratio".

To Clean the Condensate Trap

- 5.1 ▶ Pull condensate pipe out of the adapter.
- 5.2 ▶ Remove trap from boiler.
 - ▶ Clean trap and check that the connection to the heat exchanger is clear.
 - ▶ Fill the condensate trap with approximately 1/4 litre of water and refit in reverse order.

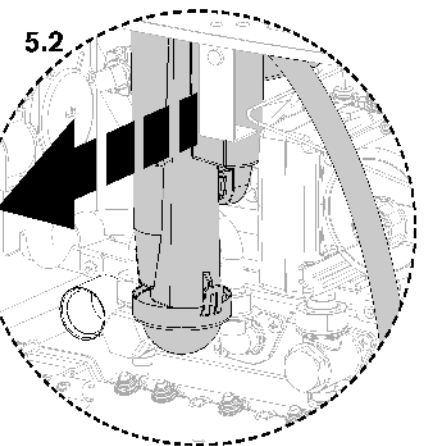
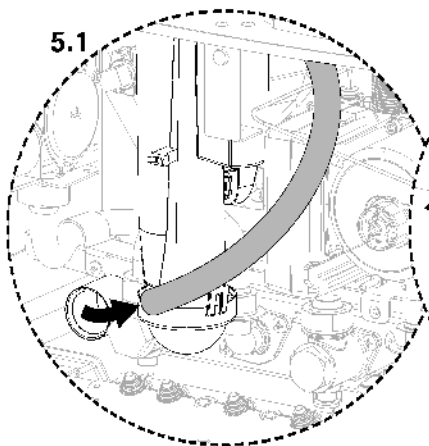
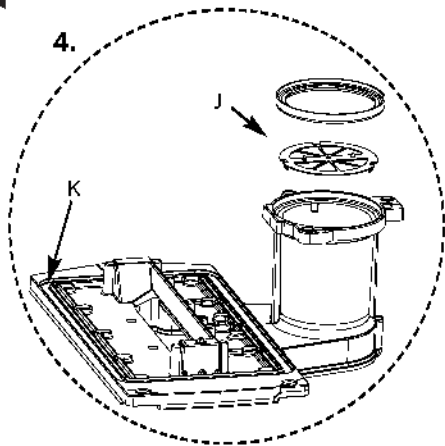
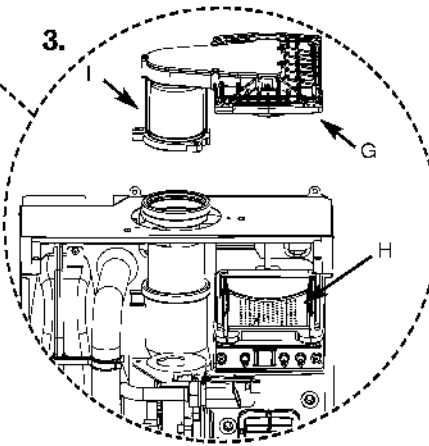
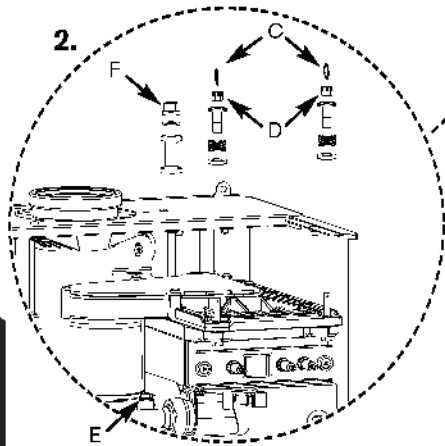
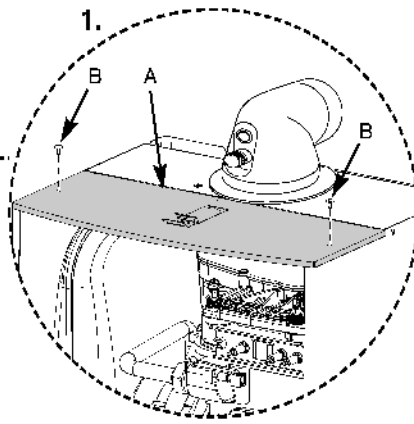
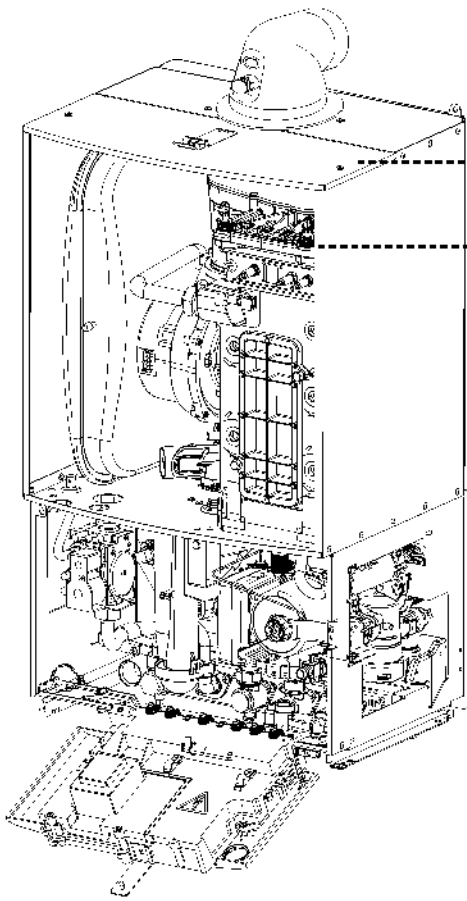

CAUTION: TURN OFF THE GAS SUPPLY AND ISOLATE THE MAINS SUPPLIES BEFORE STARTING ANY WORK AND OBSERVE ALL RELEVANT SAFETY PRECAUTIONS.

REPLACEMENT OF PARTS

IMPORTANT: AFTER REPLACEMENT OF ANY COMPONENTS ALWAYS CHECK FOR GAS SOUNDNESS WHERE RELEVANT AND CARRY OUT FUNCTIONAL CHECKS AS DESCRIBED IN COMMISSIONING. ANY O-RING OR GASKET THAT APPEARS DAMAGED MUST BE REPLACED.

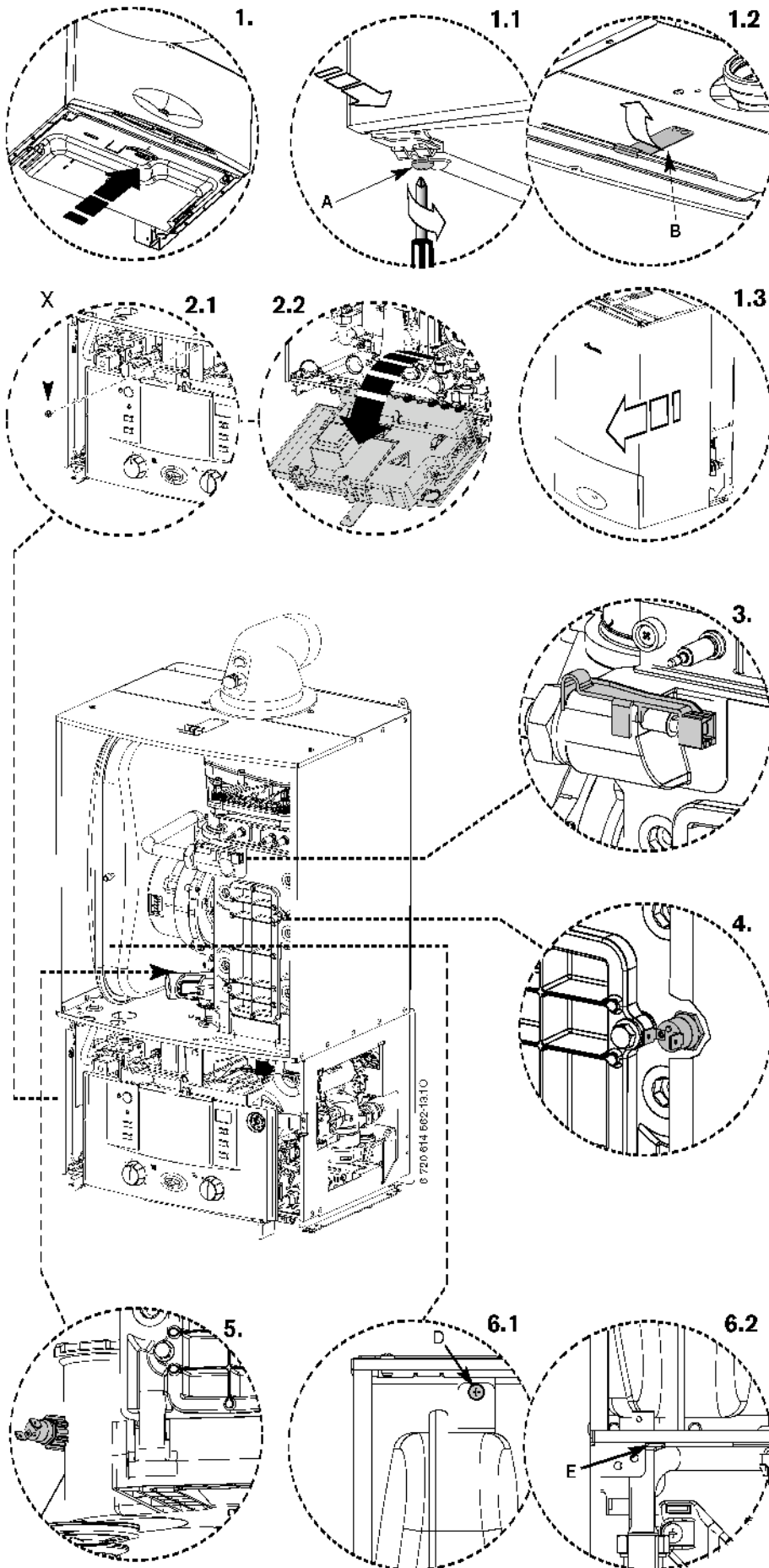

1. Removing outer case

1. ▶ Remove bottom panel by pulling it forward and off.
- 1.1 ▶ Loosen but do not remove the 2 screws (A) securing boiler casing at the bottom of the appliance.
- 1.2 ▶ Pull upwards to release the clip (B) on top of the boiler.
- 1.3 ▶ Pull case forward and remove.

2. Moving boiler control to service position

- 2.1 ▶ Remove screw (X) securing control.
- 2.2 ▶ Gently pull forward.

3. Primary sensor

- ▶ Press retaining clip on plastic moulding and pull upwards until clear of pocket in heat exchanger.
- ▶ Separate sensor from connector, coat new sensor with heat conductive paste and replace.

4. Overheat thermostat

- ▶ Remove two electrical connectors from thermostat.
- ▶ Unscrew the sensor.

5. Flue limit thermostat

- ▶ Remove electrical connections.
- ▶ Unscrew thermostat from flue.

6. Expansion Vessel

- ▶ Drain the appliance.
- 6.1 ▶ Remove locking screw (D).
- 6.2 ▶ Undo the union connection (E) at the bottom of the expansion vessel.
- ▶ Remove expansion vessel from boiler.
- ▶ Set the pressure of the new vessel to that required by the system.

7. Gas valve

- ▶ Isolate gas supply at boiler gas cock.
- ▶ Pull out air inlet tube (A).

7.1 ▶ Undo top gas connection (B) to gas valve.

7.1 ▶ Undo bottom gas connection (C) to gas valve.

7.2 ▶ Undo two securing screws (D) on the underside of casing.

- ▶ Pull valve up and forward out of boiler.

- ▶ Disconnect electrical connections.

- ▶ Replace valve with new seals and check for gas soundness.

Note: The valve will require setting, follow procedure "Setting the gas/air ratio" in the gas conversion section.

8. Siphon

8.1 ▶ Pull condensate pipe out of the adapter.

8.2 ▶ Remove trap from boiler.

- ▶ Clean trap and check that the connection to the heat exchanger is clear.

- ▶ Fill the condensate trap with approximately 1/4 litre of water and refit in reverse order.

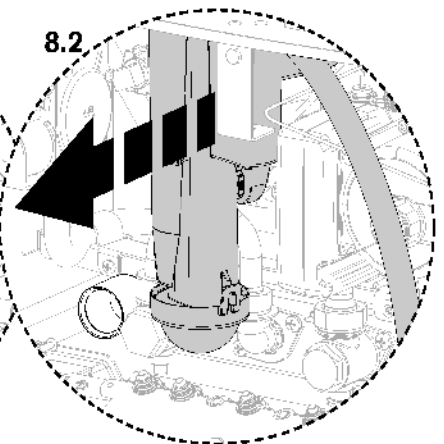
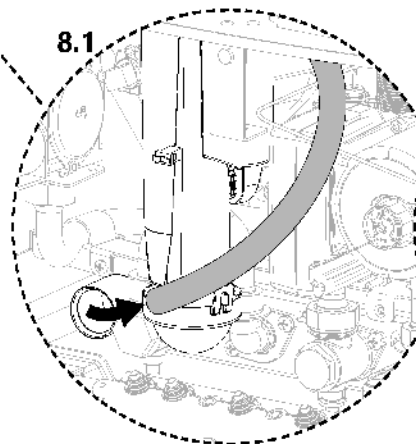
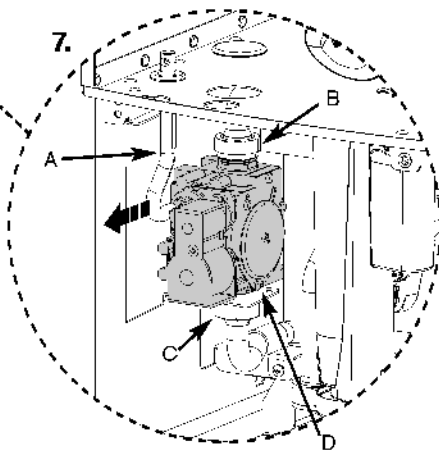
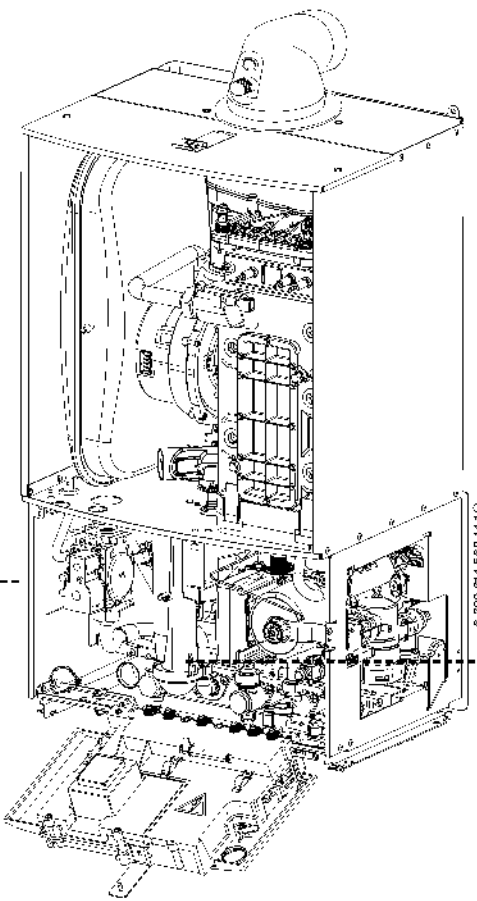

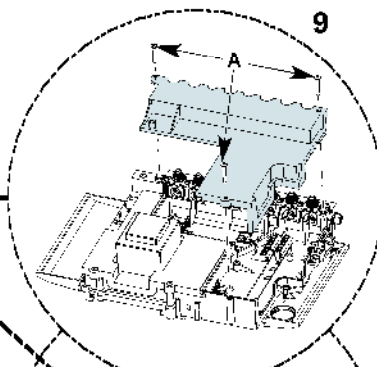
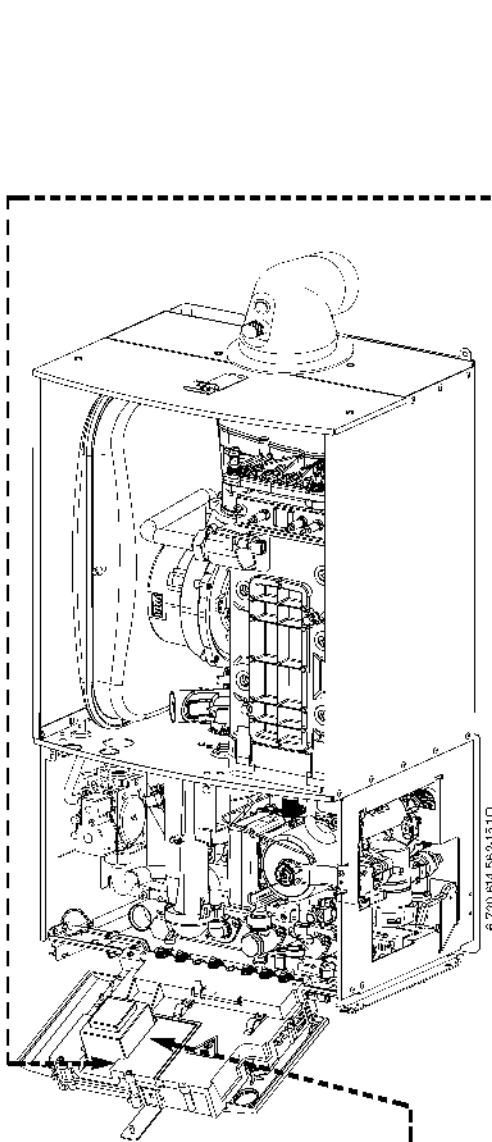

9. Access to boiler control components

▶ Remove 3 screws (A) and remove cover from control.

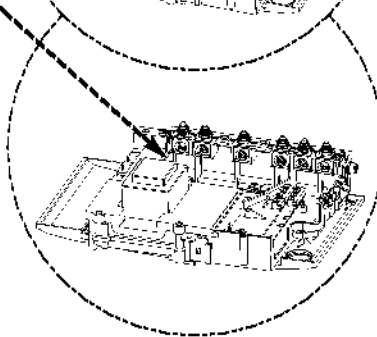

10. PCB fuse

▶ Remove fuse (B) from the PCB and replace.
▶ There is a spare fuse clipped into the cover.

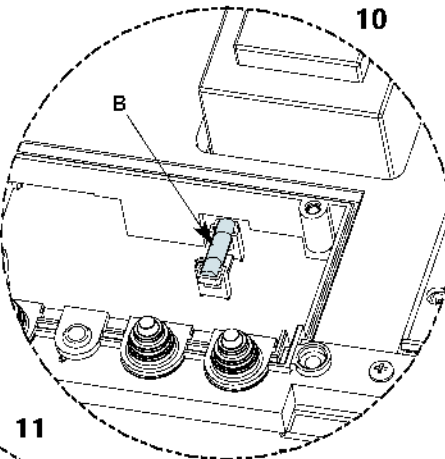

11. Transformer / PCB

▶ Disconnect all electrical connections from the control.
▶ Remove 5 screws (C) retaining the rear panel of the control and remove panel.

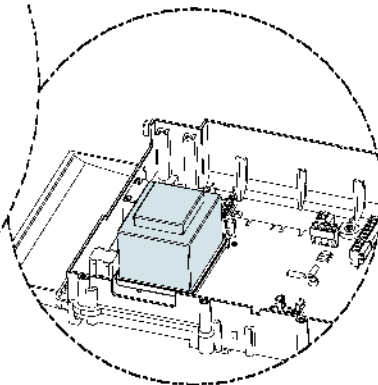
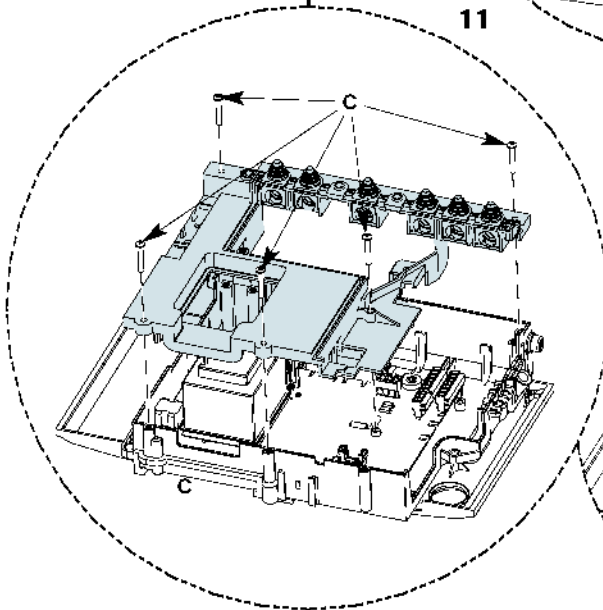

SERVICING & SPARES

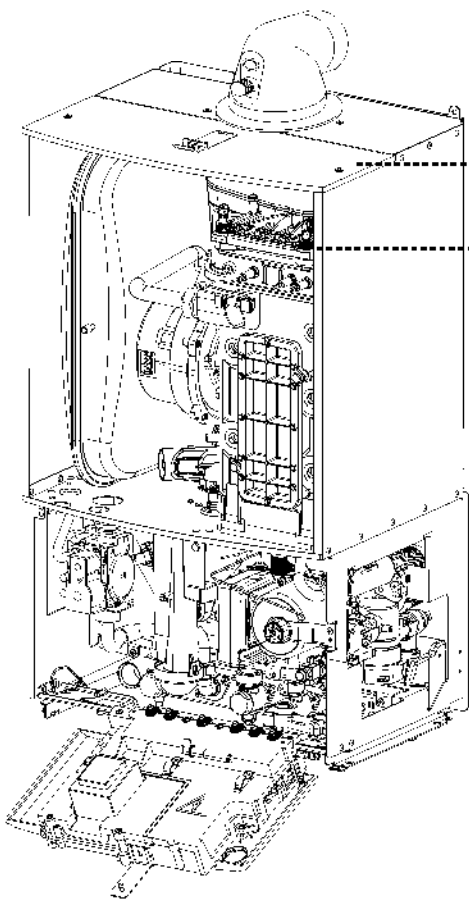

14.1

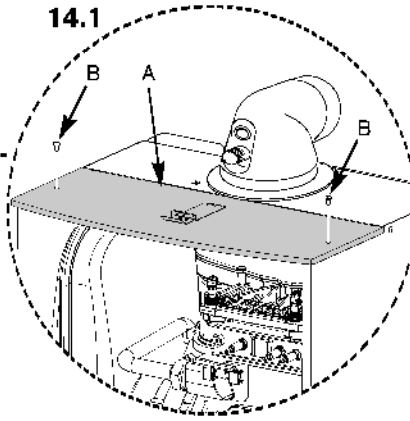

14. Air/gas manifold

- 14.1 ▶ Remove cover panel (A) by removing the screws (B).
- ▶ Check that the boiler is completely isolated from the gas supply.
- 14.2 ▶ Remove the clips (C) and unscrew the two bolts (D).
- ▶ Unscrew and remove the two hexagon screws (E) securing the fan.
- ▶ Slacken fully the rear securing bolt (F).
- 14.3 ▶ Remove air/gas manifold (I)
- 14.4 ▶ Open air/gas manifold (I).
- ▶ Carefully withdraw diaphragm (J) from fan intake tube and check for soiling and splits.

14.2

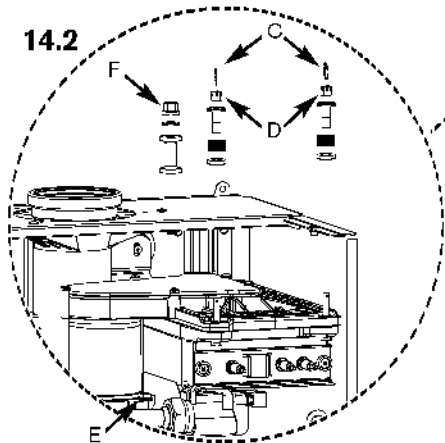

14.3

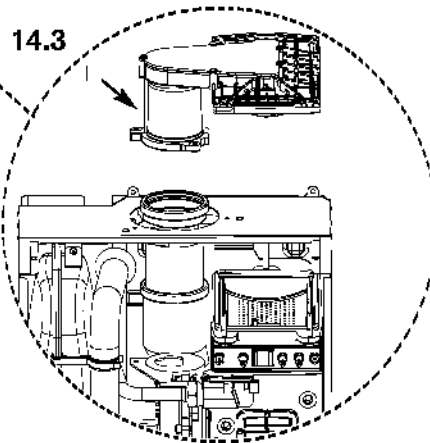

14.4

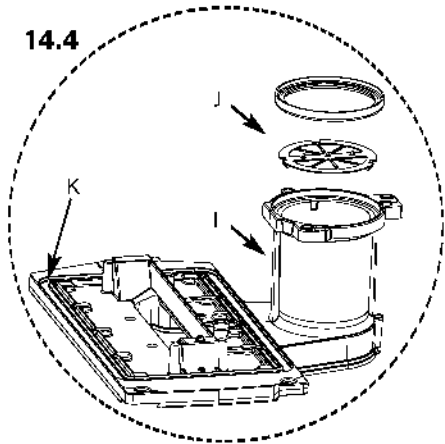

15

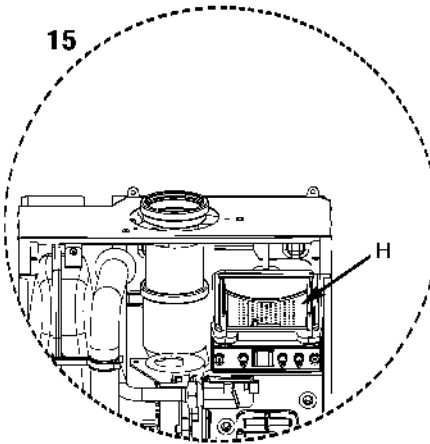

15. Burner

- ▶ Remove the burner (H).
- ▶ Replace new burner in correct position.
- ▶ Ensure that a new seal (K) is used.

SERVICING & SPARES

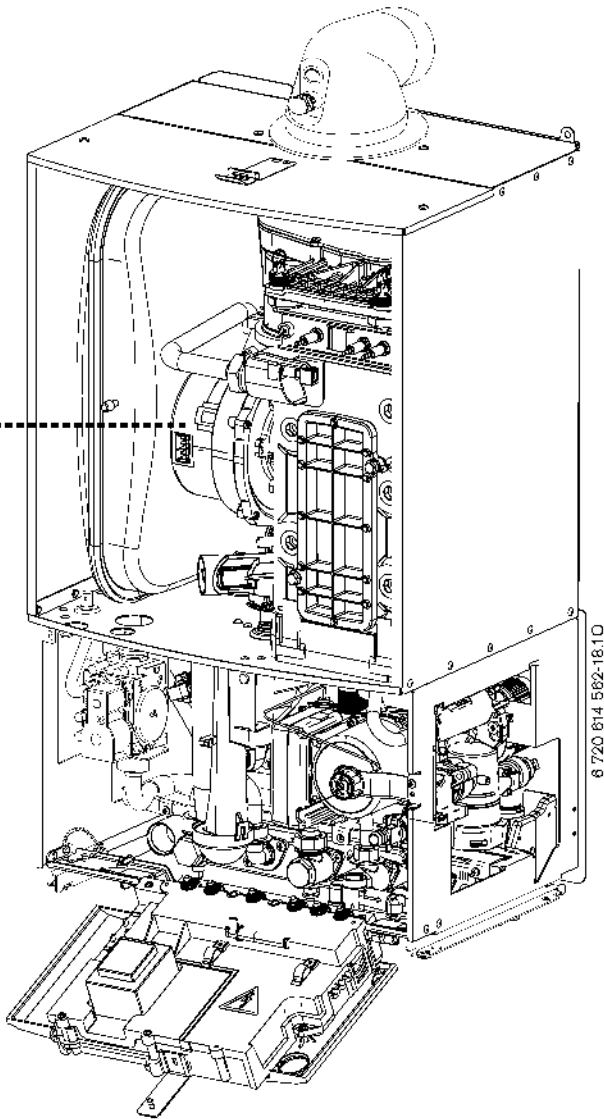

6 720 614 562-18.10

16. Heat exchanger

- ▶ Isolate flow and return valves and drain the boiler.
- ▶ Remove condensate trap (see page 42).
- ▶ Remove fan assembly (see page 46).
- 16.1** ▶ Remove plastic nut (A) from the base of the inner casing.
- 16.2** ▶ Remove return pipe at the bottom of heat exchanger.
- 16.3** ▶ Remove screw at the top of the heat exchanger (C).
- ▶ Unscrew the flow pipe (D).
- 16.4** ▶ Undo flue connection (E) from sump (F).
- ▶ Pull flue pipe up.
- ▶ Remove the heat exchanger.

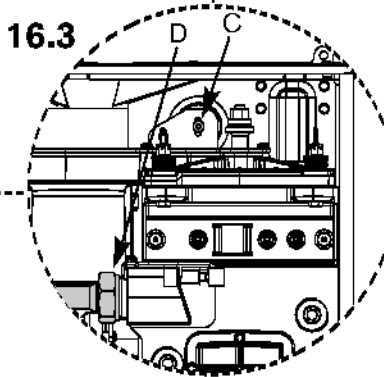
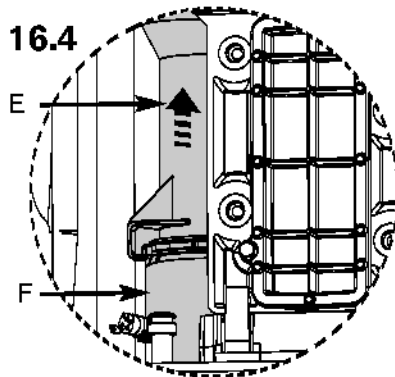
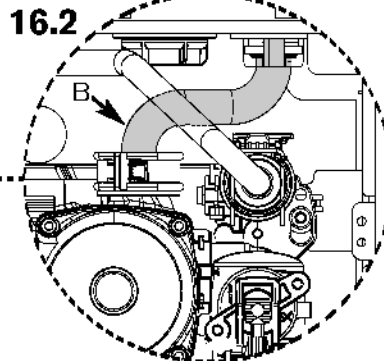
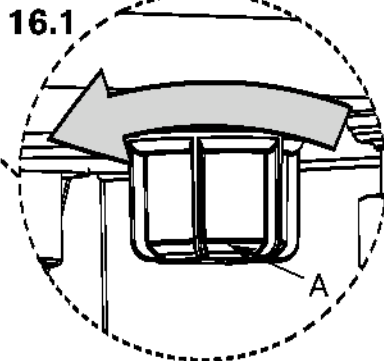

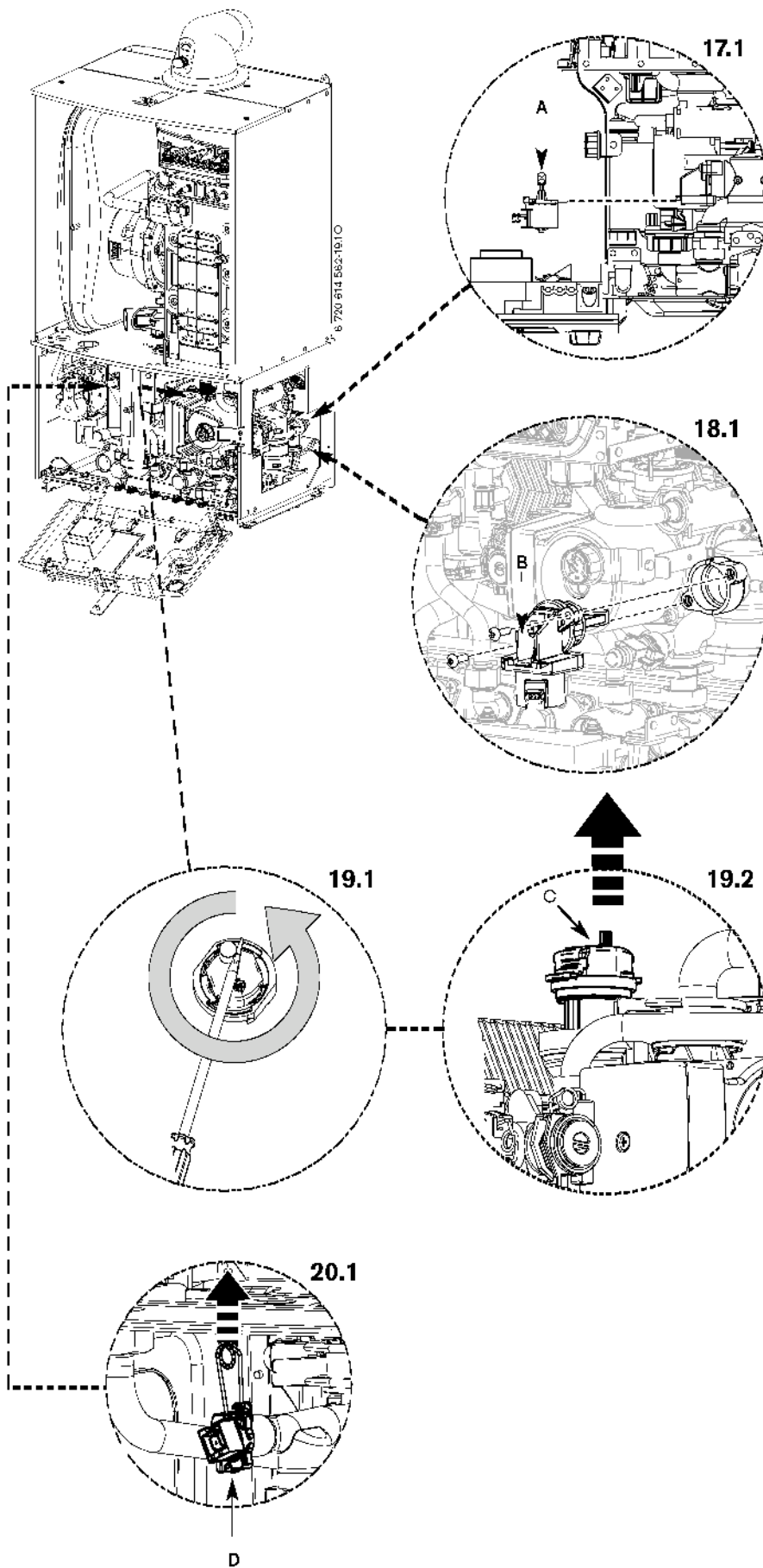

17. Diverter valve motor

There is no need to drain the appliance.
 ▶ Disconnect the electrical connector from the diverter valve motor.

17.1 ▶ Pull the motor assembly (A) towards you. The assembly will slide free from the valve.

▶ To refit, follow the above in reverse.

Note: In case of problems when refitting the motor: Connect the electrical connector to the motor and switch the appliance on. Then the motor goes to the middle position and you can refit it without difficulty.

18. Diverter valve

▶ Ensure the appliance has been fully drained.

▶ Disconnect the electrical connector from the diverter valve motor.

▶ Undo the two screws holding the valve to the plastic housing.

18.1 ▶ Withdraw the valve (B) and clean the valve chamber if necessary.

▶ To refit, follow the above in reverse. Ensure any seals that have been disturbed are renewed.

19. Auto air vent

▶ Ensure the appliance has been fully drained.

19.1 ▶ Use a screwdriver or similar to rotate the air vent anticlockwise.

19.2 ▶ Lift the air vent (C) out of the housing and remove.

▶ To refit, follow the above in reverse.

20. DHW temperature sensor

▶ Ensure the domestic hot water circuit is fully drained.

▶ Disconnect the electrical connection from the sensor.

▶ Withdraw the spring clip.

▶ Withdraw the sensor (D) from the housing.

▶ To refit, follow the above in reverse.

21. Pump head

▶ Ensure the appliance has been fully drained.

21.1 ▶ Disconnect the electrical connections from the pump following steps 1 to 4.

21.2 ▶ Remove the four Allen bolts (A) securing the pump at each corner.

21.3 ▶ Gently pull the pump towards you and remove.
▶ To refit, follow the above in reverse.

22. Pressure gauge

▶ Ensure the appliance has been fully drained.

▶ Withdraw the spring clip from the pressure sensing head housing.

▶ Undo the nut on the rear of the pressure gauge.

▶ Remove the pressure sensing head and pressure gauge capillary from the housing.

▶ To refit, follow the above in reverse. DO NOT omit the washer from the capillary when fitting a replacement gauge.

23. Flow sensor, flow restrictor housing and filter

▶ Ensure the domestic hot water circuit is fully drained.

▶ Disconnect the electrical connection to the turbine.

▶ Remove the spring clip from the housing and move the brass pipe to one side.

23.1 ▶ Withdraw the flow sensor and filter from the housing.

▶ Using the cartridge tag, withdraw the flow restrictor housing. If the regulator housing has become stuck, a pair of long nosed pliers may be used to grip the housing.

▶ To refit, follow the above in reverse. Ensure any seals that have been disturbed are renewed.

24. Flow regulator

▶ Remove the flow restrictor housing (See Removing the flow sensor, flow regulator and filter).

24.1 ▶ Using a small Allen key or similar, push the flow restrictor cartridge out of its housing.

▶ To refit, follow the above in reverse. Ensure any seals that have been disturbed are renewed.

25. Drain tap

▶ Ensure the appliance has been fully drained.

25.1 ▶ Rotate the drain tap fully anticlockwise.

25.2 ▶ Withdraw the drain tap from its housing.

▶ To refit, follow the above in reverse. Ensure any seals that have been disturbed are renewed.

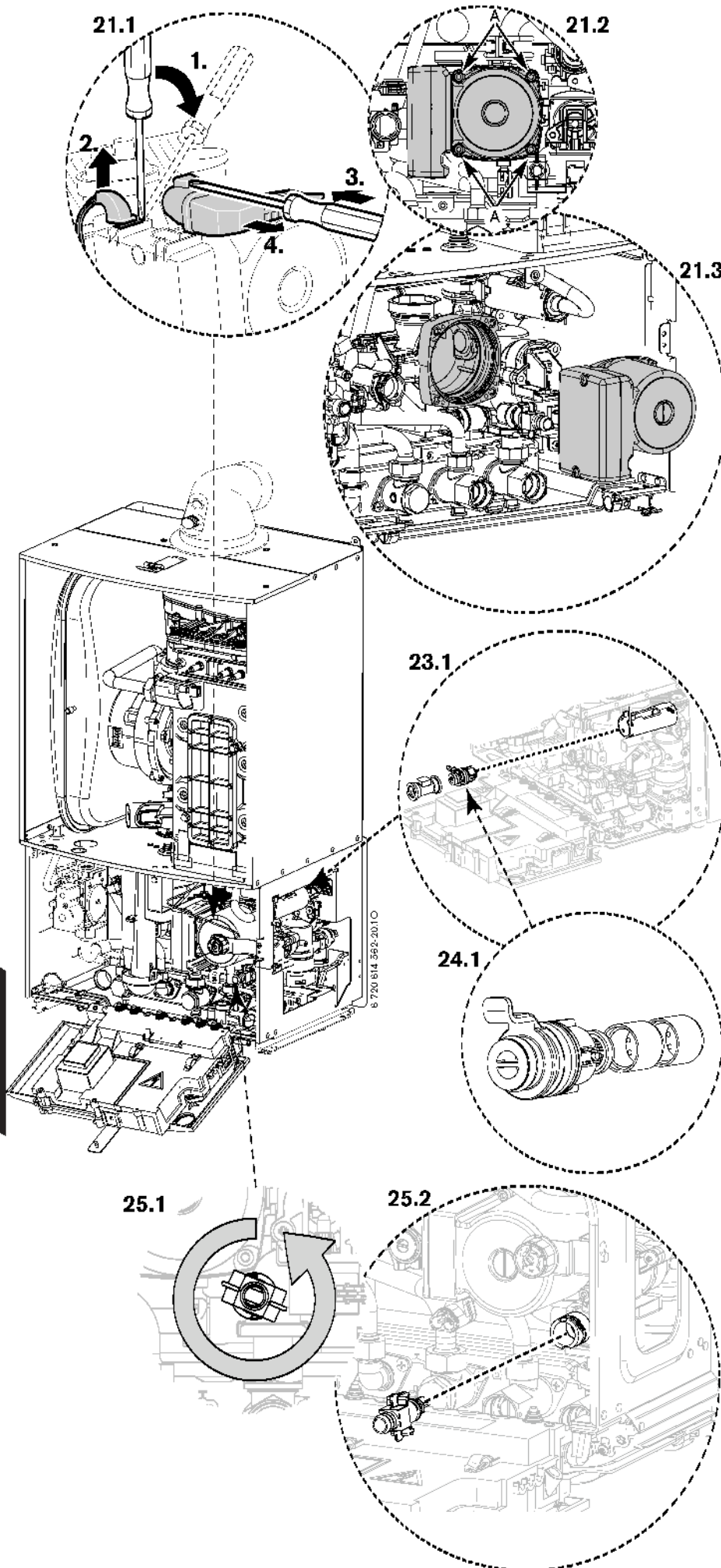

26.1

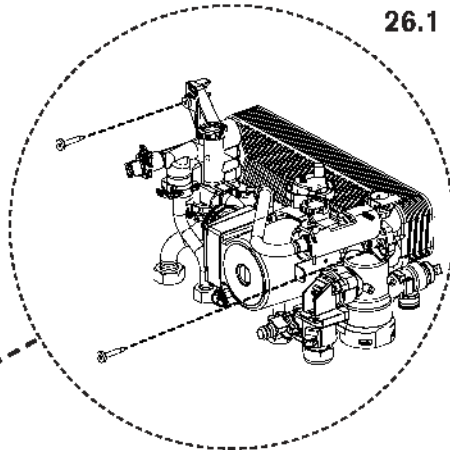

26.2

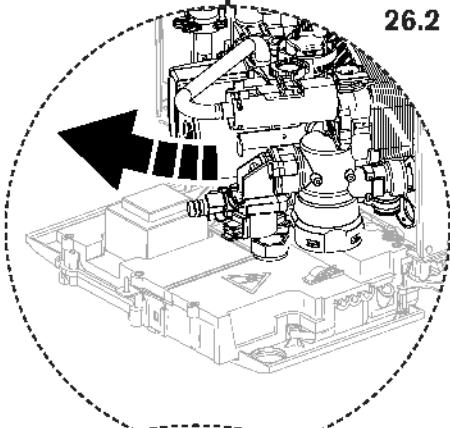

26. Hydraulic Block

- ▶ Ensure the appliance has been fully drained.
- ▶ Disconnect the electrical connections to the NTC, Turbine and pump.
- ▶ Undo the nuts securing the copper water pipes to the manifold (there is no need to remove the gas pipe).
- ▶ Release the spring clips securing these water pipes to the plastic housing and remove the pipes.
- ▶ Release the spring clip securing the expansion vessel pipe to the plastic housing and remove the pipe.
- ▶ Undo the nut securing the pressure gauge to its bracket and remove the gauge.
- ▶ Release the locking devices that secure the two copper water pipes leading to the combustion chamber by squeezing the two tabs together and rotating anticlockwise (viewed from above).

26.1 ▶ Undo the two screws securing the hydraulic block to the chassis (located top left/top right of the housing).

26.2 ▶ Lift the left hand side of the block slightly, then manoeuvre the block out, starting with the right hand side.
▶ Take care not to snag the harness or pressure gauge bracket.

NOTE: the block will still contain a small amount of water, which will spill if the block is tilted.

▶ To refit, follow the above in reverse. Ensure any seals that have been disturbed are renewed.

27. CH pressure relief valve

▶ Remove the Hydraulic block from the boiler (See Removing the Hydraulic Block).

27.1 ▶ Remove the spring clip from the Pressure relief valve housing.

27.2 ▶ Withdraw the pressure release valve (A) from its housing.

▶ To refit, follow the above in reverse. Ensure any seals that have been disturbed are renewed.

27.1

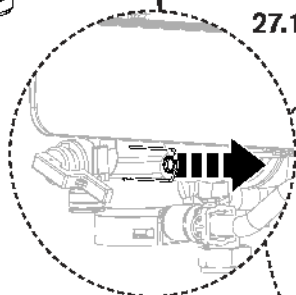

27.2

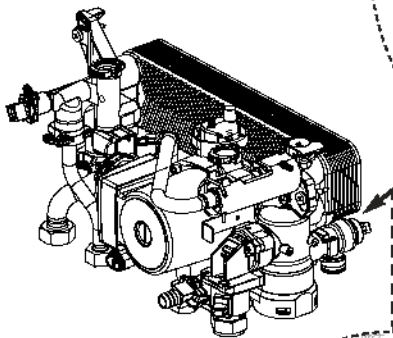
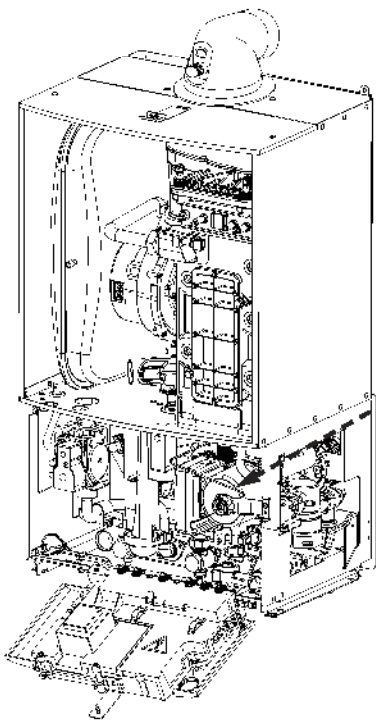
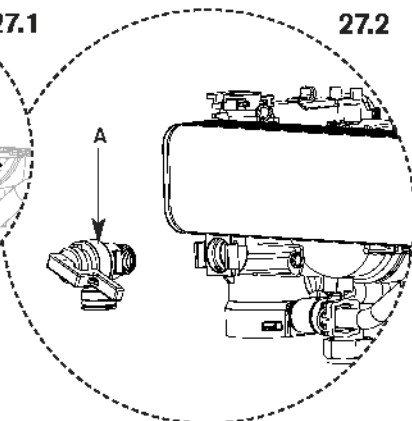

SERVICING & SPARES

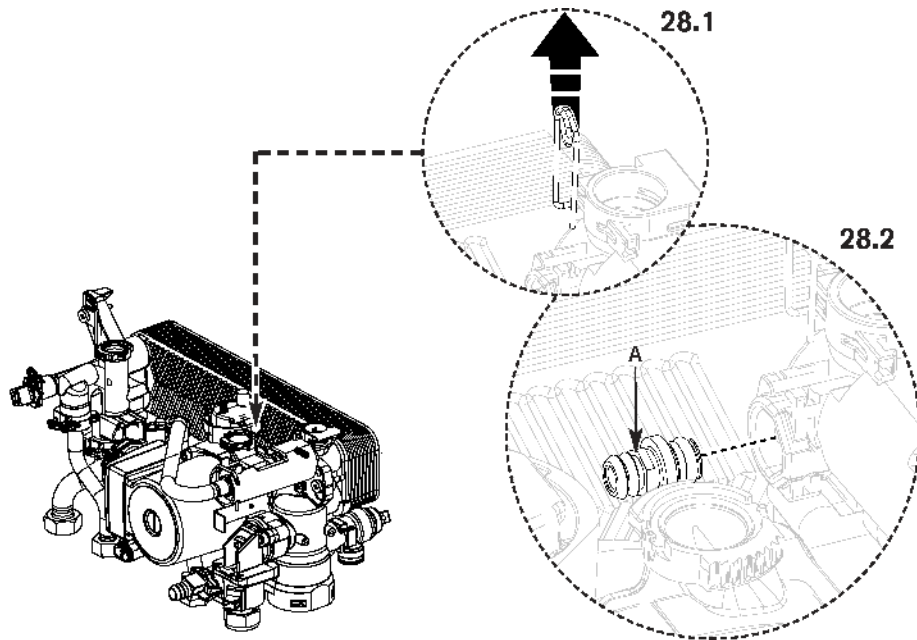

28. Plastic protection device

- ▶ Ensure the system is fully drained.
- ▶ Disconnect all pipes connected to the pump housing.
- ▶ Remove the electrical connection to the pump.
- ▶ Withdraw the metal clip to the right of the pump head to release the pump housing.
- ▶ Slide the device to the left and then withdraw it from the appliance.

28.1 ▶ Remove the spring clip from the pressure relief valve housing.

28.2 ▶ Withdraw the pressure relief valve (A).
▶ To refit, follow the above in reverse. Ensure any seals that have been disturbed are renewed.

29. DHW Heat exchanger

- ▶ Remove the Hydraulic block from the boiler (See Removing the Hydraulic Block).

29.1 ▶ Undo the two screws (B) securing the plastic housings to the heat exchanger.

29.2 ▶ Remove the heat exchanger.
▶ To refit, follow the above in reverse. Ensure any seals that have been disturbed are renewed.

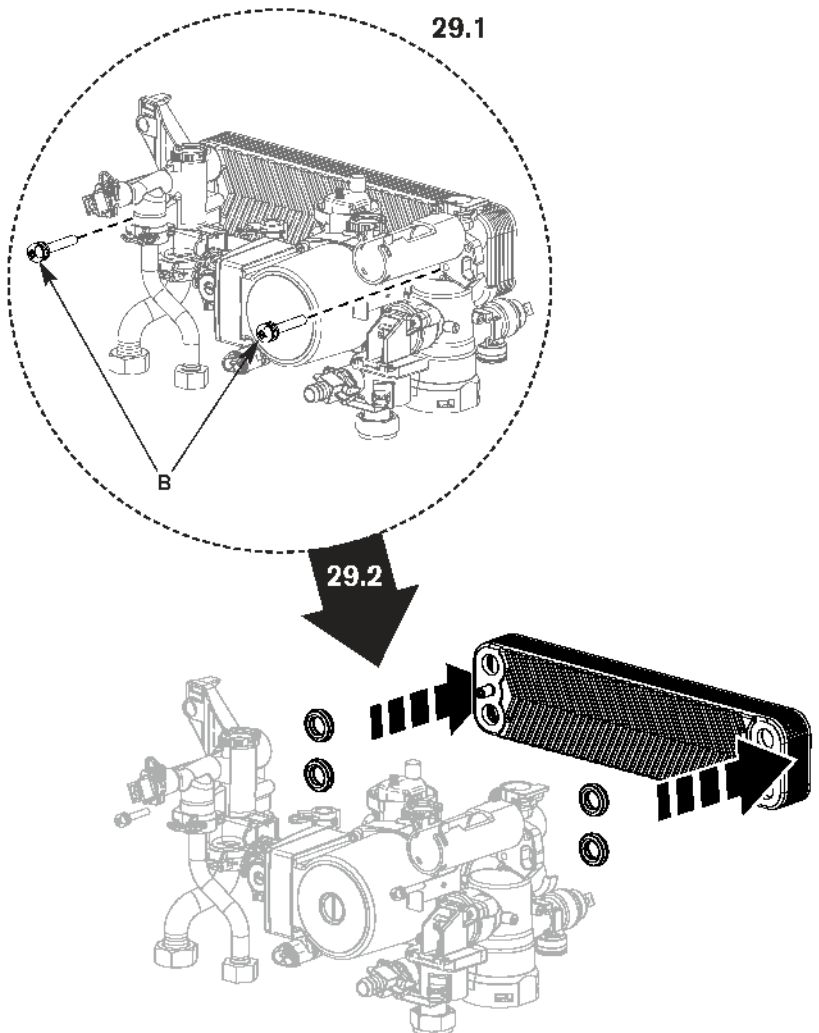

THE SETTING OF THE GAS RATIO MUST BE CARRIED OUT BY A COMPETENT PERSON. SETTING OF THE GAS RATIO MUST **NOT** BE ATTEMPTED UNLESS THE PERSON CARRYING OUT THE CONVERSION IS EQUIPPED WITH A COMBUSTION ANALYSER CONFORMING TO BS 7927 AND IS COMPETENT IN ITS USE.

SETTING THE GAS/AIR RATIO

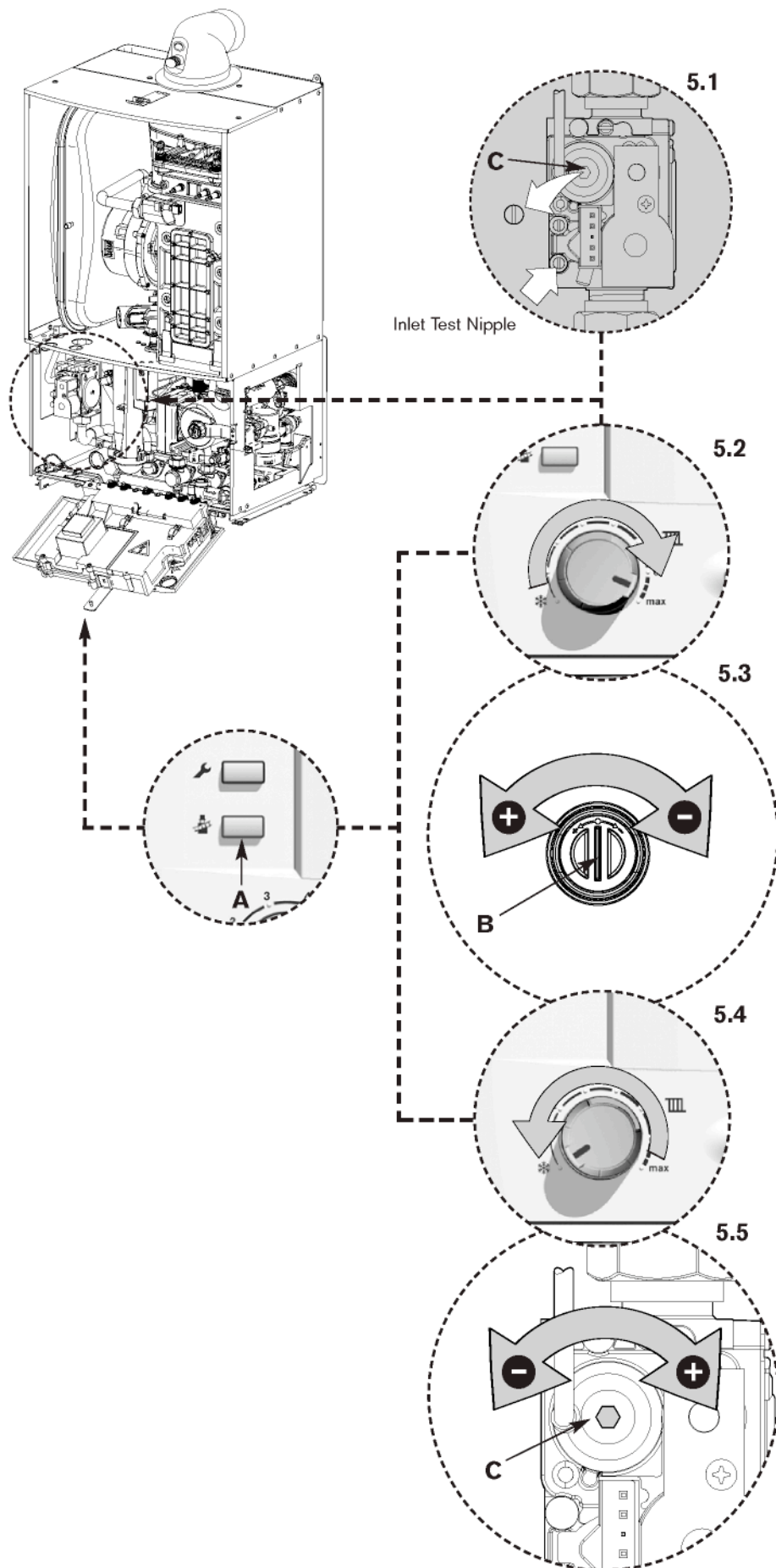

5. Setting the CO₂

Note: When running in the central heating boost mode, the boiler will operate both the central heating & DHW circuits. This is to allow sufficient time for the setting procedure. It will be necessary to run water through the DHW circuit to ensure that the boiler will not cycle on low heating demands.

- 5.1** ▶ Connect manometer to inlet pressure point on the gas valve.
- ▶ To adjust the CO₂ it will be necessary to first operate the boiler at maximum output.
 - ▶ Press and hold down the central heating boost button (A) for 10 seconds until illuminated.
- 5.2** ▶ Turn central heating control to maximum; the boiler will then go to maximum output.
- Note:** The control will resume normal operation after 15 minutes or if the central heating boost button is pressed for over a second.
- 5.3** ▶ Using a flat blade screwdriver set the CO₂ via adjuster (B) using table below.
- Note:** CO₂ should be measured 10 minutes after firing the appliance.

Gas type	CO ₂ setting maximum	CO ₂ setting minimum
Greenstar 27CDi and 30CDi		
Natural gas	9.6 % ±0.2	9.0 % ±0.2
LPG	11.5 % ±0.2	10.5 % ±0.2
Greenstar 37CDi and 42CDi		
Natural gas	9.7 % ±0.2	9.1 % ±0.2
LPG	11.5 % ±0.2	10.5 % ±0.2

- ▶ Check CO is less than 200 ppm.
 - ▶ Measure the inlet pressure; it should be a minimum of 18 mbar for natural gas and 37 mbar for LPG.
- 5.4** ▶ Set the central heating control to minimum. This will make the boiler go to minimum power.
- 5.5** ▶ Measure the CO₂; it should now be at the figure for minimum output. If not adjust (C) on the gas valve until correct.
- ▶ Return to maximum and re-check the CO₂. If correct press and hold down the central heating boost button for 2 seconds; the button will cease to be illuminated and the blue power indicator will be permanently illuminated.
 - ▶ Remove manometer and re-seal inlet pressure point on gas valve.
 - ▶ Fit new plastic sealing cover on to outlet adjuster (B).
 - ▶ Fit white cover over valve adjuster (C) and secure with black security tag.
 - ▶ Remove red arrow from data plate and fit new one in correct position for gas type.
 - ▶ Re-assemble and refit boiler case.
 - ▶ Re-connect mains electrical supply and check boiler operation as stated in the commissioning section.
 - ▶ Fit new label from kit over existing label on the appliance bottom panel.

L.P.G. CONVERSION

ISOLATE MAINS ELECTRICAL SUPPLY AND REMOVE OUTER CASE AS SHOWN IN THE INSTALLATION, COMMISSIONING & SERVICING INSTRUCTIONS

THE CONVERSION MUST BE CARRIED OUT BY A COMPETENT PERSON. IT MUST **NOT** BE ATTEMPTED UNLESS THE PERSON CARRYING OUT THE CONVERSION IS EQUIPPED WITH A COMBUSTION ANALYSER CONFORMING TO BS 7927 AND IS COMPETENT IN ITS USE.

Important: The appliance shall not be installed into a room or internal space below ground level when it is intended for use with LPG (propane - G31). This does not preclude the installation into a room or space which is a basement on one side of the building but open to ground on the opposite side.

Installation Regulations

In addition to those specified in the main booklet the following standard applies when converting to an LPG appliance: **BS 5842 Domestic Propane Gas Burning Installations.**

All conversions will require the air gas ratio to be set correctly for the gas used. The procedure for setting the air gas ratio is at the rear of these instructions.

1. Moving boiler control to service position

- ▶ Remove boiler case, as described on page 39.

- 1.1 ▶ Remove screw (X) from retaining bracket.
- 1.2 ▶ Lower control panel into service position.

2. Code plug

- 2.1 ▶ Remove 3 screws (D) retaining plastic cover at rear of control box and remove.
- 2.2 ▶ Replace code plug (E) with new one supplied with conversion kit.

	Gas type	Code plug No.
27CDi	Natural Gas	1020
	LPG	1021
30CDi	Natural Gas	1012
	LPG	1013
37CDi	Natural Gas	1014
	LPG	1015
42CDi	Natural Gas	1016
	LPG	1017

- ▶ Replace plastic cover.
- ▶ Place control in normal position and secure with screw.

THE GAS / AIR RATIO MUST BE RESET AFTER CONVERSION. THE PROCEDURE CAN BE FOUND IN THE REPLACEMENT PARTS SECTION OF THIS MANUAL.

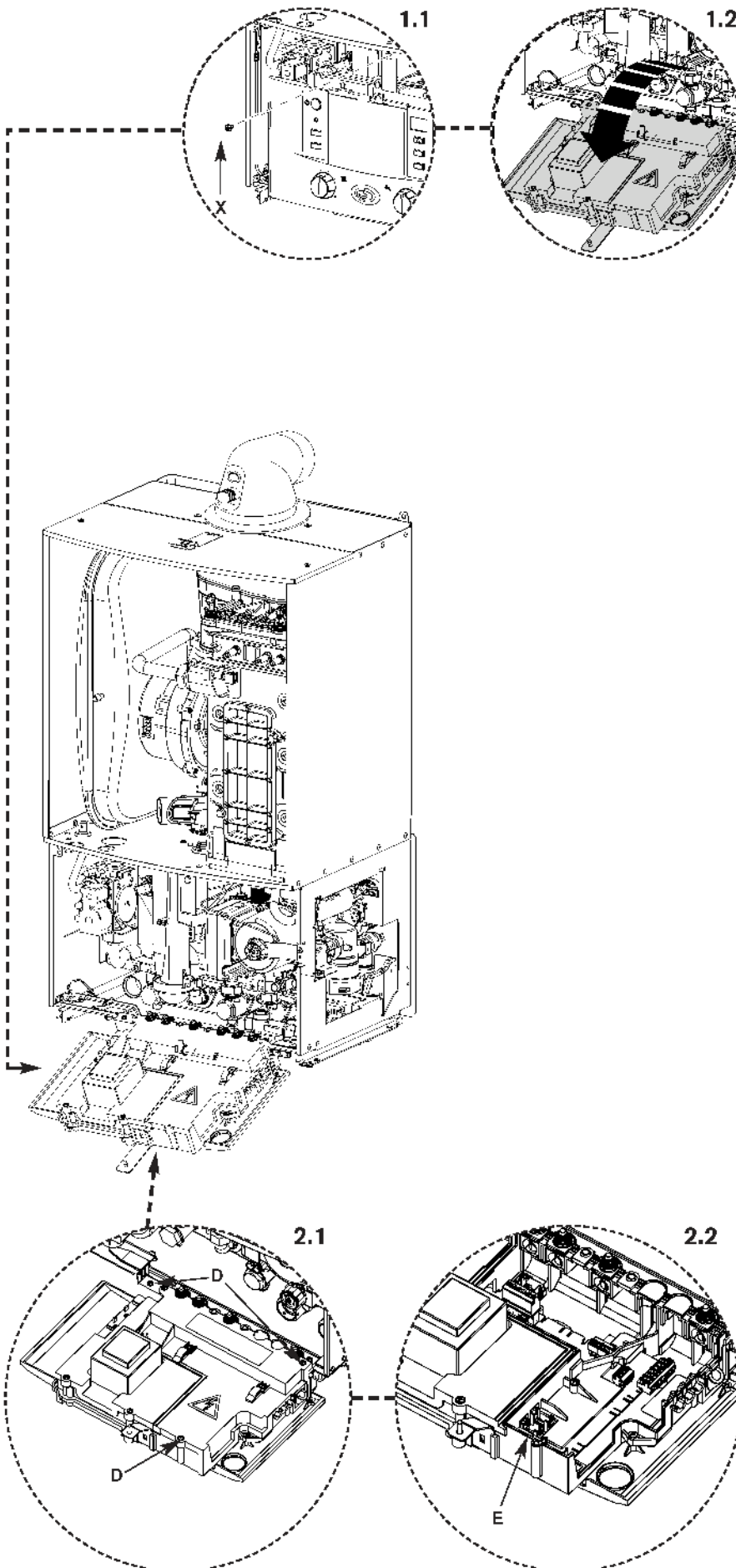

CONVERSION
KITS

NOTE: This fault finding information is for guidance only. Worcester Bosch cannot be held responsible for costs incurred by persons not deemed to be competent.

The electronic control system for this boiler incorporates a blue central indicator. This normally confirms the permanent mains supply but, by flashing during a fault, provides a guide to the cause as listed.

This fault finding system assumes that the appliance has been operating normally until the time of failure (i.e. not a first installation error).

PRELIMINARY CHECKS: Preliminary electrical system checks are the first electrical checks to be carried out during a fault-finding procedure. On completion of the Service/Fault-Finding task which has required the breaking and remaking of electrical connections, check (a) EARTH CONTINUITY, (b) SHORT CIRCUIT CHECK, (c) POLARITY and (d) RESISTANCE TO EARTH.

An optional text display is available which gives a text description of the service functions of the boiler

Display code	Description	Remedy
A7	Hot water NTC sensor defective.	Check hot water NTC sensor and connecting lead for circuit breaks/short circuits.
A8	Break in communication to TD200 or/and RT10.	Check electrical connections.
b1	Code plug not detected.	Insert code plug correctly, test and replace if necessary.
C6	Fan speed too low.	Check fan lead and connector, and fan; replace as necessary.
E2	CH flow NTC sensor defective.	Check CH flow NTC sensor and connecting lead.
E9	Safety temp. limiter in CH flow has tripped.	Check system pressure, check safety temp. limiters, check pump operation, check fuse on pcb, bleed appliance.
EA	Flame not detected.	Is gas cock turned on? Check gas supply pressure, power supply, igniter electrode and lead, ionisation sensing electrode and lead, flue duct and CO ₂ level.
F0	Internal error.	Check electrical connector contacts, programmer interface module ignition leads are not loose; replace pcb if necessary.
F7	Flame detected even though appliance switched off.	Check electrode assembly, dry pcb. Flue clear?
FA	Flame detected after gas shut off.	Check gas valve and wiring to gas valve. Clean condensation trap and check electrode assembly. Flue clear?
Fd	Reset button pressed by mistake.	Press reset button again.

More detailed fault finding procedures are described in the Service booklet for the Engineer number 6 720 612 361.

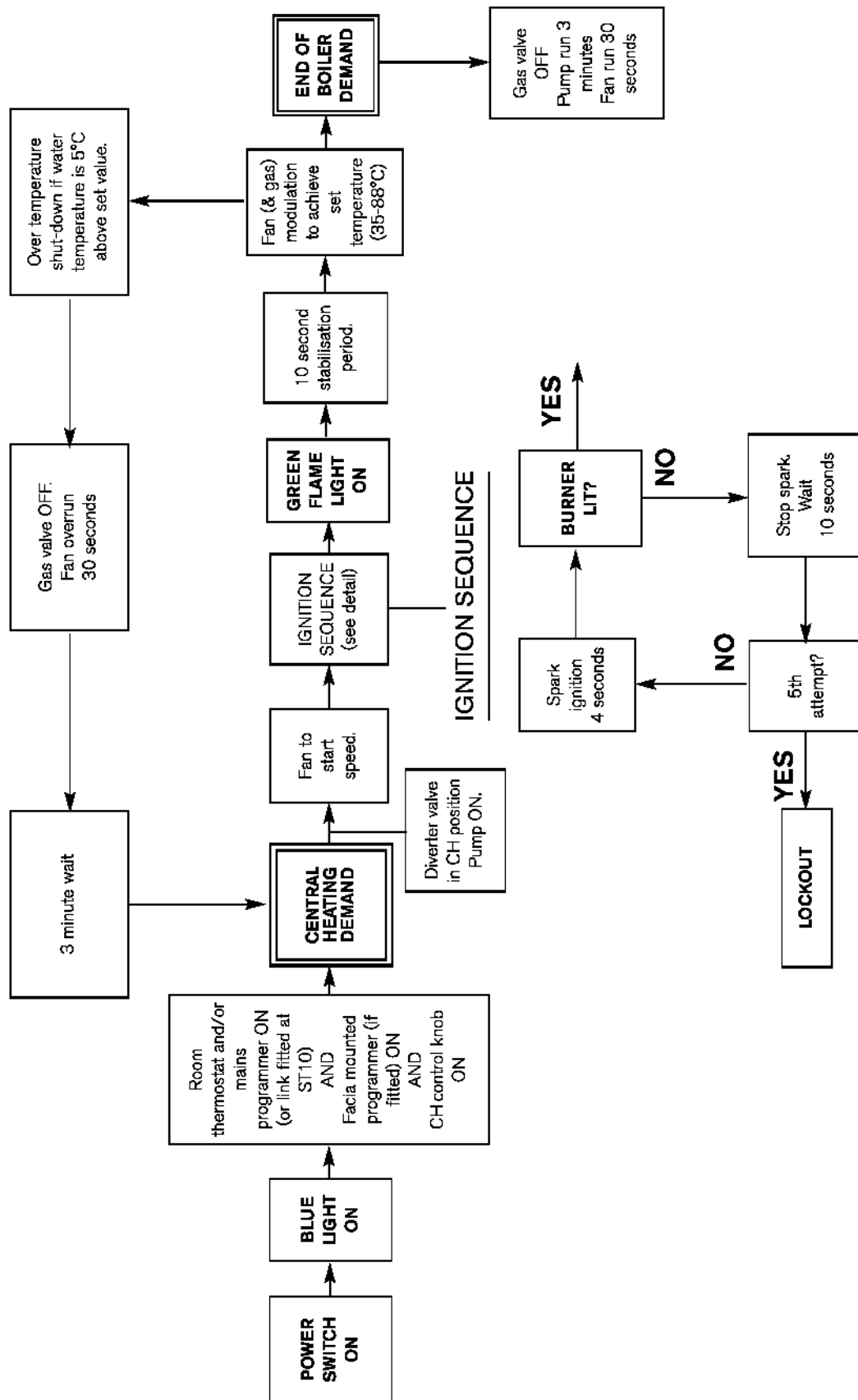

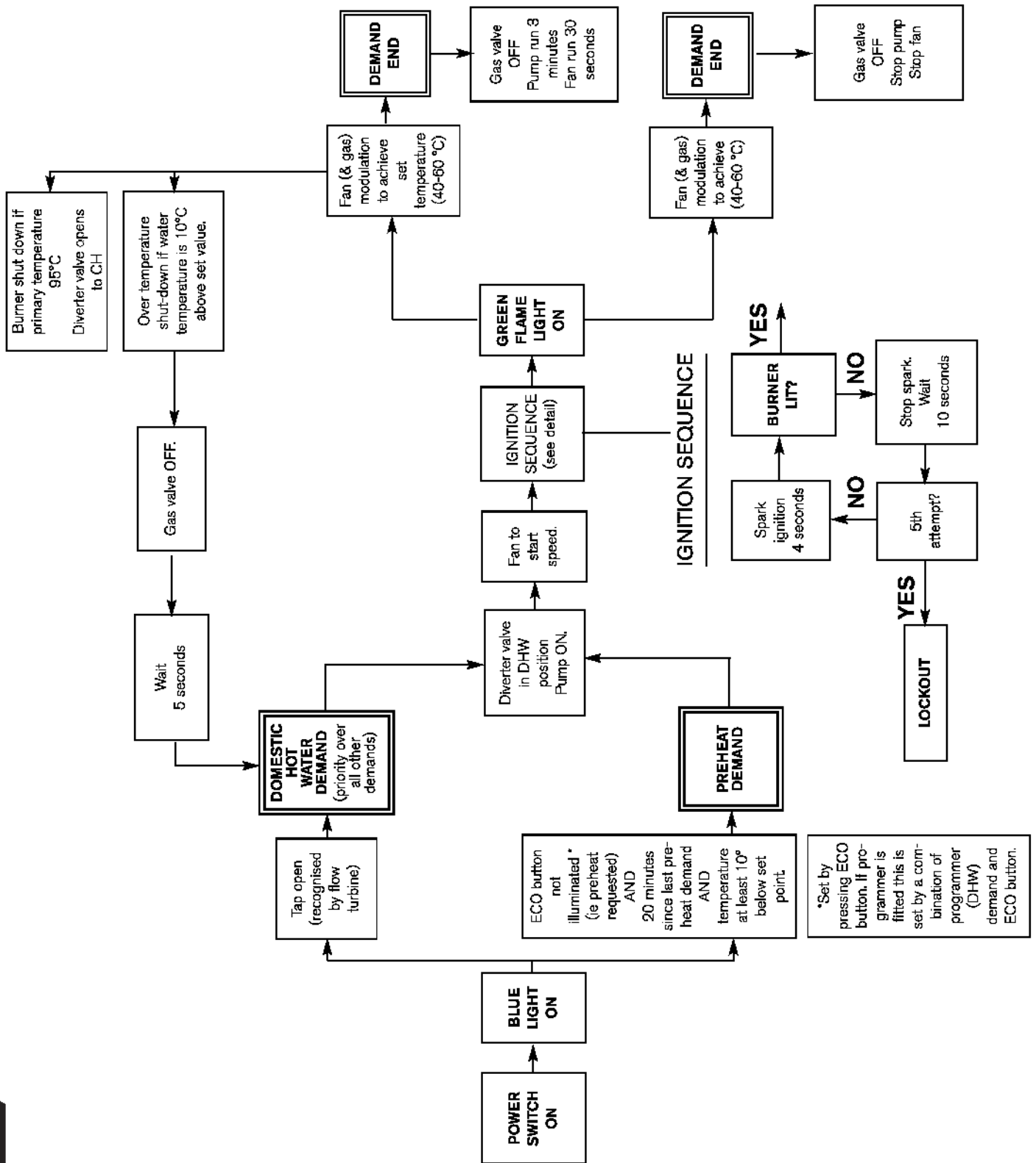

*Set by pressing ECO button. If programmer is fitted this is set by a combination of programmer (DHW) demand and ECO button.

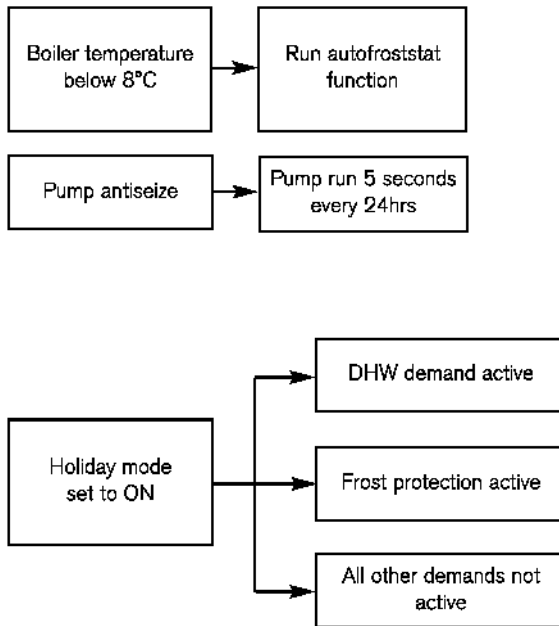

INSTRUCTION MANUAL INSTALLATION, COMMISSIONING & SERVICING

EXCELLENCE COMES AS STANDARD

Worcester, Bosch Group

Cotswold Way, Warndon, Worcester WR4 9SW.

Tel. 01905 754624 Fax. 01905 754619

Worcester, Bosch Group is a trading name of

BBT Thermotechnology UK Ltd.

www.worcester-bosch.co.uk

6 720 614 564a (2007/07) OSW



WORCESTER
Bosch Group