

# GREENSTAR CDi CONVENTIONAL

WALL HUNG RSF GAS-FIRED CONDENSING REGULAR BOILER  
FOR OPEN VENTED AND SEALED CENTRAL HEATING SYSTEMS AND INDIRECT  
DOMESTIC HOT WATER



THE APPLIANCE IS FOR USE WITH  
NATURAL GAS OR L.P.G. (Cat II 2H3P TYPE C13 & C33)

**NATURAL GAS:**

WORCESTER GREENSTAR 30CDi Conventional  
GC NUMBER 41-311-71  
WORCESTER GREENSTAR 40CDi Conventional  
GC NUMBER 41-311-72

**LIQUID PETROLEUM GAS :**

WORCESTER GREENSTAR 30CDi Conventional  
GC NUMBER 41-311-73  
WORCESTER GREENSTAR 40CDi Conventional  
GC NUMBER 41-311-74

GB/IE

**INSTRUCTION MANUAL  
INSTALLATION, COMMISSIONING  
& SERVICING**

 **WORCESTER**  
Bosch Group



## CONTACT INFORMATION

### WORCESTER BOSCH:

TECHNICAL: 08705 266241  
SERVICE: 08457 256206  
SPARES: 01905 752571  
LITERATURE: 01905 752556  
TRAINING: 01905 752526  
SALES: 01905 752640  
WEBSITE: [www.worcester-bosch.co.uk](http://www.worcester-bosch.co.uk)

### WATER TREATMENT:

FERNOX 01799 550811  
[www.fernox.com](http://www.fernox.com)

SENTINEL 0151 420 9595  
[www.betzdearborn.com/sentinel](http://www.betzdearborn.com/sentinel)

### FLUE TERMINAL GUARD:

TOWER FLUE COMPONENTS  
VALE RISE  
TONBRIDGE  
TN9 1TB

STORE THE APPLIANCE IN A DRY AREA  
PRIOR TO INSTALLATION.

#### LIFTING AND CARRYING PRECAUTIONS:

- Lift only a manageable weight, or ask for help.
- When lifting the boiler, bend the knees, and keep the back straight and feet apart.
- Do not lift and twist at the same time.
- Lift and carry the boiler close to the body
- Wear protective clothing and gloves to protect from any sharp edges

## INSTALLATION & SERVICING INSTRUCTIONS

### PLEASE READ THESE INSTRUCTIONS CAREFULLY BEFORE STARTING INSTALLATION.

THESE INSTRUCTIONS ARE APPLICABLE TO THE WORCESTER BOSCH APPLIANCE MODEL(S) STATED ON THE FRONT COVER OF THIS MANUAL ONLY AND MUST NOT BE USED WITH ANY OTHER MAKE OR MODEL OF APPLIANCE.

THE INSTRUCTIONS APPLY IN THE UK ONLY AND MUST BE FOLLOWED EXCEPT FOR ANY STATUTORY OBLIGATION.

THIS APPLIANCE MUST BE INSTALLED BY A COMPETENT PERSON. FAILURE TO INSTALL CORRECTLY COULD LEAD TO PROSECUTION.

IF YOU ARE IN **ANY DOUBT** CONTACT WORCESTER BOSCH TECHNICAL HELPLINE.

DISTANCE LEARNING AND TRAINING COURSES ARE AVAILABLE FROM WORCESTER BOSCH.

**PLEASE LEAVE THESE INSTRUCTIONS, THE USER GUIDE AND THE COMPLETED BENCHMARK LOG BOOK OR A CERTIFICATE CONFIRMING COMPLIANCE WITH IS 813 (EIRE ONLY) WITH THE USER OR AT THE GAS METER AFTER INSTALLATION OR SERVICING.**

#### ABBREVIATIONS USED IN THIS MANUAL:

∅ Diameter  
NG Natural Gas  
LPG Liquid Petroleum Gas  
CH Central Heating  
DHW Domestic Hot Water  
IP Ingress Protection  
SEDBUK Seasonal Efficiency of Domestic Boilers in the United Kingdom

#### SYMBOLS USED IN THIS MANUAL:



Central heating

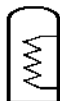

Hot water storage cylinder



Electricity supply



Gas supply



Time clock



Programmer/timer



Room thermostat



Wait time period

# CONTENTS

## SAFETY & REGULATIONS

SAFETY PRECAUTIONS	4
INSTALLATION REGULATIONS	4

## APPLIANCE INFORMATION

GENERAL INFORMATION	5
TECHNICAL DATA	6
LAYOUT & COMPONENTS	7

## PRE-INSTALLATION

CLEANING PRIMARY SYSTEMS	8
MAINS SUPPLIES	9
WATER SYSTEMS & PIPEWORK	10
CONDENSATE PIPEWORK	11
BOILER LOCATION & CLEARANCES	12-13
PLUMBING MANIFOLD	14
FLUE TERMINAL POSITIONS	15
FLUE OPTIONS	16-17

## INSTALLATION

UNPACKING WALL FRAME AND ANCILLARY ITEMS	18
WALL MOUNTING PLATE / FLUE OPENING	19
PIPEWORK	20
UNPACKING THE APPLIANCE	21
FITTING THE APPLIANCE / BOILER CONNECTIONS	22
FLUE INSTALLATION	23-25
CONDENSATE CONNECTION	26
ELECTRICAL	27-28
POSITION OF WIRED COMPONENTS	29

## COMMISSIONING

PRE-COMMISSIONING CHECKS	30
FILLING THE SYSTEM	31
STARTING THE APPLIANCE	32
WATER TREATMENT	33
COMMISSIONING	34
FINISHING COMMISSIONING	35

## SERVICING & SPARES

INSPECTION AND SERVICE	36-40
REPLACEMENT OF PARTS	41-47
SETTING THE GAS/AIR RATIO	48
SHORT PARTS LIST	49

## CONVERSION KITS

L.P.G. CONVERSION	50
-------------------	----

## FAULT FINDING & DIAGNOSIS

FAULT FINDING	51
HEATING FUNCTION	52
PROTECTION FUNCTION	53

SAFETY &  
REGULATIONS

APPLIANCE  
INFORMATION

PRE-  
INSTALLATION

INSTALLATION

COMMISSIONING

SERVICING  
& SPARES

CONVERSION  
KITS

FAULT FINDING  
& DIAGRAMS

## SAFETY PRECAUTIONS

### IF YOU SMELL GAS:

- ✗ **DON'T** SMOKE OR STRIKE MATCHES
- ✗ **DON'T** TURN ELECTRICAL SWITCHES ON OR OFF
- ✓ **DO** PUT OUT NAKED FLAMES
- ✓ **DO** OPEN DOORS AND WINDOWS
- ✓ **DO** KEEP PEOPLE AWAY FROM THE AREA AFFECTED
- ✓ **DO** TURN OFF THE CONTROL VALVE AT THE METER
- ✓ TELEPHONE THE NATIONAL GAS EMERGENCY SERVICE ON 0800 111999

### **benchmark**

A Benchmark Log Book is provided by the manufacturer for the installer to complete including their **CORGI** registration number to confirm that the boiler has been installed, commissioned and serviced according to the manufacturer's instructions.

**IMPORTANT:** The completed Benchmark Checklist will be required in the event of any warranty work and may be required by the local Building Control Inspector.

### HEALTH & SAFETY

The appliance contains no asbestos and no substances have been used in the construction process that contravene the COSHH Regulations (Control of Substances Hazardous to Health Regulations 1988).

### COMBUSTIBLE AND CORROSIVE MATERIALS

Do not store or use any combustible materials (paper, thinners, paints etc.) inside or within the vicinity of the appliance.

Chemically aggressive substances, such as halogenated hydrocarbons containing chlorine or fluorine compounds can corrode the appliance and invalidate any warranty.

### FITTING & MODIFICATIONS

Fitting the appliance and any controls to the appliance may only be carried out by a competent engineer in accordance with the Gas Safety (Installation and Use) Regulations 1998.

Flue systems must not be modified in any way other than as described in the fitting instructions. Any misuse or unauthorised modifications to the appliance, flue or associated components and systems could invalidate the warranty. The manufacturer accepts no liability arising from any such actions, excluding statutory rights.

### SERVICING

Advise the user to have the system serviced annually by a competent, qualified engineer (such as British Gas or CORGI registered personnel) using approved spares, to help maintain the economy, safety and reliability of the appliance.

**IMPORTANT - The service engineer must complete the Service Record in the Benchmark section after each service.**

## INSTALLATION REGULATIONS

Gas Safety (Installation & Use) Regulations: All gas appliances must be installed by a competent person in accordance with the above regulations. Failure to install appliances correctly could lead to prosecution.

The appliance must be installed in accordance with, and comply to, the current: Gas Safety Regulations, IEE Regulations, Building Regulations, Building Standards (Scotland) (Consolidation), Building Regulations (Northern Ireland), local water by-laws, Health & Safety Document 635 (The Electricity at Work Regulations 1989) and any other local requirements.

### British Standards:

The relevant British Standards should be followed, including:

BS7074:1 : Code of practice for domestic and hot water supply

BS6891 : Installation of low pressure gas pipework up to 28mm (R1)

BS5546 : Installation of gas hot water supplies for domestic purposes

EN:12828 : Central heating for domestic premises

BS5440:1 : Flues and ventilation for gas appliances of rated heating not exceeding 70kW (net) : Flues

BS5440:2 : Flues and ventilation for gas appliances of rated heating not exceeding 70kW (net) : Air Supply

BS7593 : Treatment of water in domestic hot water central heating systems

BS 6798 : Installation of gas fired boilers of rated input up to 70kW (net)

Where no specific instruction is given, reference should be made to the relevant British Standard codes of Practice.

### L.P.G. Installation:

An appliance using L.P.G. must not be installed in a room or internal space below ground level unless one side of the building is open to the ground.

### Timber framed buildings:

Where the boiler is to be fitted to a timber framed building the guidelines laid down in BS5440: Part 1 and IGE "Gas Installations in Timber Frame Buildings" should be adhered to.

### CH water:

Artificially softened water must not be used to fill the central heating system.

## STANDARD PACKAGE:

- A - Wall hung gas fired condensing boiler for central heating and indirect domestic hot water
- B - Wall mounting plate
- C - Hanging bracket
- D - Hardware pack 1
- E - Hardware pack 2 (gas cock)
- F - Literature pack
- G - Bottom panel
- H - Trap / Syphon Outlet Connection (22 mm Plastic Pipe)
- J - Flow pipe
- K - Return pipe 1
- L - Return pipe 2
- M - Pipework mounting bracket
- N - Gas cock support plate
- O - Braising template

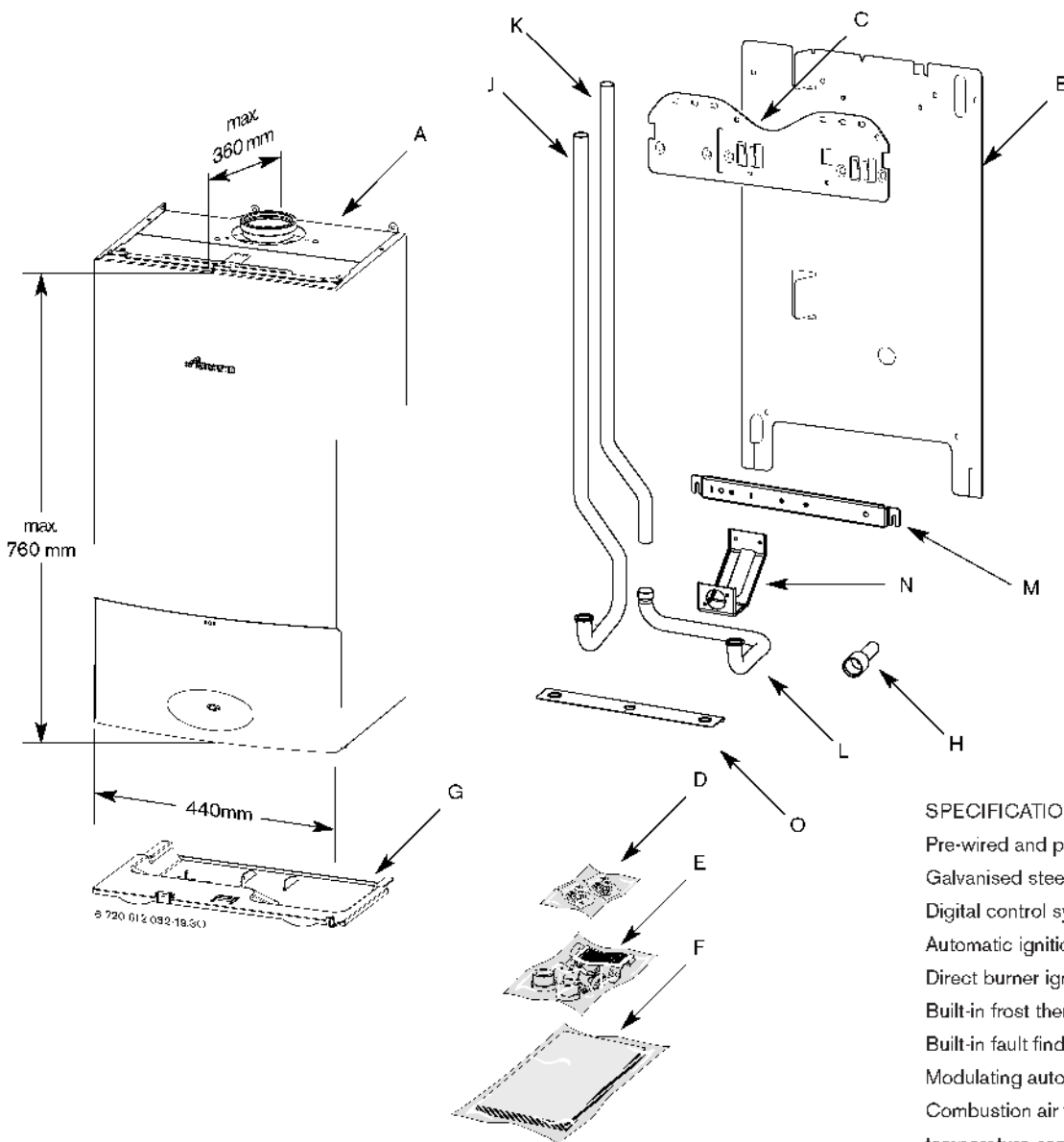

## SPECIFICATIONS:

- Pre-wired and pre-plumbed
- Galvanised steel inner frame
- Digital control system
- Automatic ignition
- Direct burner ignition
- Built-in frost thermostat (boiler protection)
- Built-in fault finding diagnostics
- Modulating automatic gas valve
- Combustion air fan with speed regulator
- temperature sensor & control
- External pump anti-seizure protection
- Flue gas temperature limiter
- Condensate trap & syphon

## TECHNICAL DATA

DESCRIPTION	UNITS	NATURAL GAS		L.P.G.	
		30CDi	40CDi	30CDi	40CDi
<b>Heating</b>					
Max. rated heat input	kW	30.9	42.0	30.9	42.0
Max. rated heat output net 40/30°C	kW	32.1	43.7	32.1	43.7
Max. rated heat output net 50/30°C	kW	31.8	43.3	31.8	43.3
Max. rated heat output net 80/60°C	kW	30.0	40.8	30.0	40.8
Min. rated heat output net 40/30°C	kW	8.6	10.6	12.4	15.7
Min. rated heat output net 50/30°C	kW	8.6	10.5	12.3	15.5
Min. rated heat output net 80/60°C	kW	7.7	9.4	11.0	13.9
Min. rated heat input net	kW	8.0	9.8	11.5	14.5
Max. flow temperature	°C	nom. 90	nom. 90	nom. 90	nom. 90
Max. permissible operating pressure	bar	3.0	3.0	3.0	3.0
<b>Gas flow rate - Max. 10 minutes from lighting</b>					
Natural Gas G20	m <sup>3</sup> /h	3.2	4.4	-	-
Propane Gas (LPG)	kg/h	-	-	2.4	3.3
<b>Flue</b>					
Flue Gas Temp. 80/60°C, rated min. load	°C	76/58	87/58	76/58	87/58
Flue Gas Temp. 40/30°C, rated min. load	°C	55/33	58/35	55/33	58/35
CO <sub>2</sub> level at max. rated heat output	%	9.6	9.7	11.5	11.5
CO <sub>2</sub> level at min. rated heat output	%	9.0	9.1	10.5	10.5
NOx - class		5	5	5	5
<b>Condensate</b>					
Max. condensation rate	l/h	2.7	3.7	2.7	3.7
pH value, approx.		4.8	4.8	4.8	4.8
<b>Electrical</b>					
Electrical power supply voltage	AC...V	230	230	230	230
Frequency	Hz	50	50	50	50
Max. power consumption	W	approx. 70	approx. 100	approx. 70	approx. 100
<b>General Data</b>					
SEDBUK	band	A	A	A	A
Appliance protection rating	IP	X4D	X4D	X4D	X4D
Permissible ambient temperatures	°C	0-50	0-50	0-50	0-50
Nominal capacity of appliance	l	3.5	3.5	3.5	3.5
Noise output level	dB(A)	43	47	43	47
Total boiler weight (lift weight)	kg	39.5	39.5	39.5	39.5
Packaged boiler weight	kg	48	48	48	48
SEDBUK	%	90.1	90.2	90.1	90.2

## LAYOUT & COMPONENTS

The diagram opposite shows the controls in the servicing position and excludes the outer case.

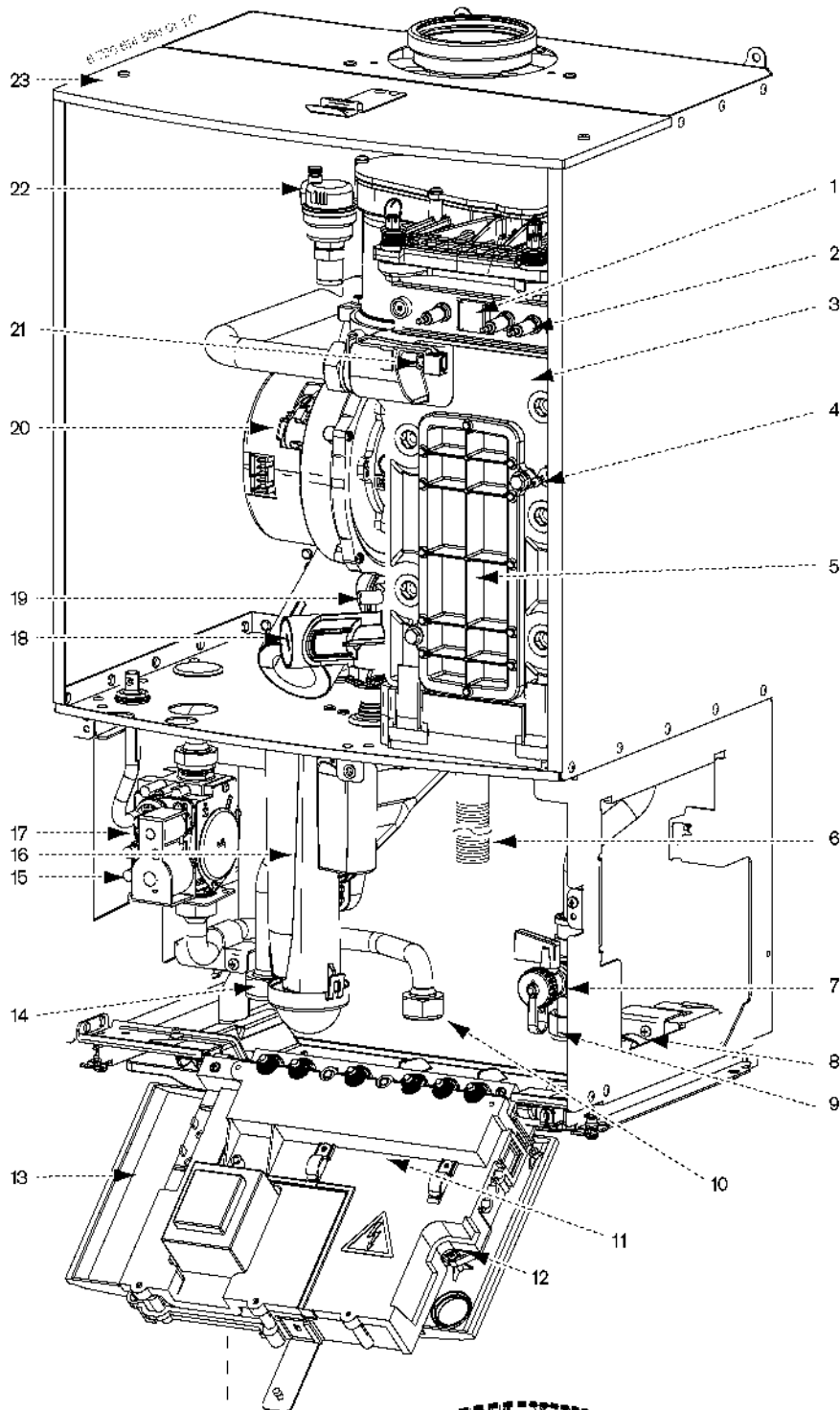

- 1 FLAME VIEWING WINDOW
- 2 IGNITION ELECTRODE AND FLAME SENSE ELECTRODE
- 3 HEAT EXCHANGER
- 4 OVERHEAT THERMOSTAT
- 5 ACCESS POINT FOR CLEANING HEAT EXCHANGER
- 6 CONDENSATE HOSE
- 7 DRAIN POINT
- 8 TRAP / SYPHON OUTLET CONNECTION (22 mm PLASTIC PIPE)
- 9 RETURN
- 10 GAS INLET CONNECTION 22 mm COMPRESSION
- 11 COVER FOR EXTERNAL WIRING CONNECTIONS
- 12 CONTROL PANEL IN SERVICE POSITION
- 13 ACCESS COVER FOR TRANSFORMER & PCB
- 14 FLOW
- 15 INLET PRESSURE TEST POINT
- 16 TRAP / SYPHON
- 17 GAS VALVE
- 18 AIR / GAS ADJUSTMENT SCREW
- 19 TESTING POINT FOR FAN PRESSURE
- 20 FAN
- 21 PRIMARY SENSOR
- 22 AUTO AIR VENT
- 23 REMOVABLE TOP CASE PANEL FOR SERVICING

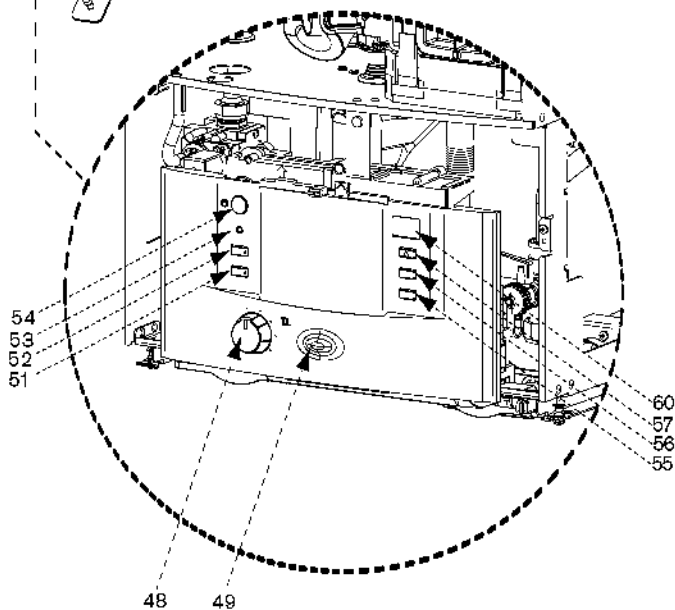

- 48 TEMPERATURE CONTROL
- 49 MAINS ON/OFF INDICATOR/DIAGNOSTIC LIGHT (BLUE)
- 51 BOOST BUTTON
- 52 SERVICE BUTTON
- 53 BURNER ON INDICATOR LIGHT (GREEN)
- 54 MASTER SWITCH ON/OFF
- 55 NOT USED
- 56 NOT USED
- 57 FAULT RESET BUTTON
- 60 DISPLAY

**IMPORTANT: All the following Pre-Installation sections must be read and requirements met before starting boiler or flue installation.**

**CAUTION: ISOLATE THE MAINS SUPPLIES BEFORE STARTING ANY WORK AND OBSERVE ALL RELEVANT SAFETY PRECAUTIONS.**

**IMPORTANT: Debris from the system can damage the boiler and reduce efficiency. Failure to comply with the guidelines for the use of water treatment with the appliance will invalidate the appliance warranty.**

**BEFORE CLEANING THE SYSTEM:  
ENSURE THE SYSTEM AND PIPEWORK IS IN GOOD WORKING ORDER**

**KEEP THE EXISTING BOILER/ CIRCULATING PUMP WHERE POSSIBLE OR USE A POWER FLUSHING MACHINE TO AID THE CLEANSING PROCEDURE BEFORE INSTALLING A NEW BOILER.**

**CLEANING THE PRIMARY SYSTEM:**

- 1 Fill the system with cold water and check for leaks.
- 2 Open all drain cocks and drain the system.
- 3 Close drain cocks and add a suitable flushing agent at the correct strength for the system condition in accordance with the manufacturer's instructions.
  - ▶ Circulate the flushing agent before the boiler is fired up.
- 4 Run the boiler/system at normal operating temperature as directed by the manufacturer of the flushing agent.
- 5 Drain and thoroughly flush the system to remove the flushing agent and debris.

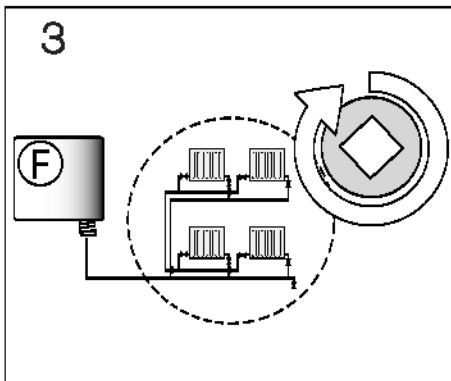
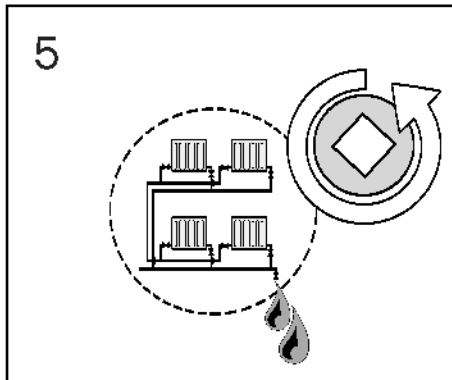
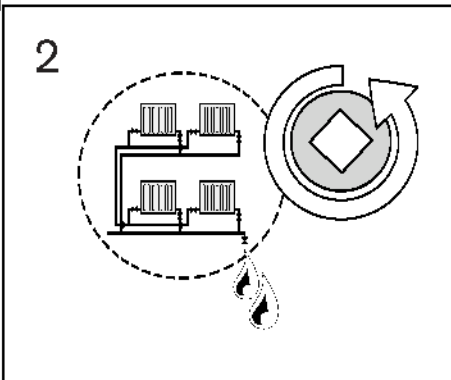
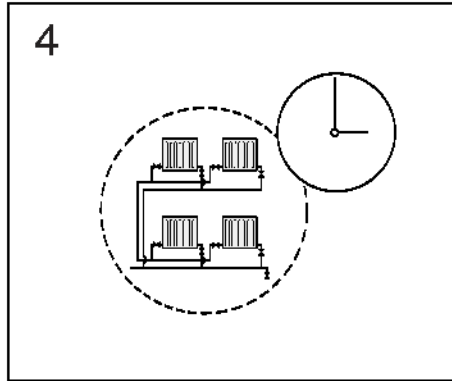
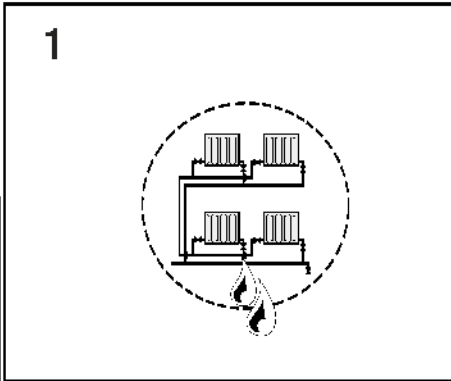

**KEY**



Valve



Flushing Agent

## MAINS SUPPLIES



### ELECTRIC SUPPLY:

- Supply: 230V - 50Hz  
(See Technical Data for IP ratings.)
- Cable: PVC insulated 0.75mm<sup>2</sup>  
(24 x 0.2mm) temperature rated to 90°C.
- External 3A fuse to BS1362.
- The appliance must be earthed.
- All pipes to the boiler must be cross-bonded.
- Wiring must comply with IEE wiring regulations and any local regulations which may apply to fixed wiring to a stationary appliance.



### GAS SUPPLY:

- Boilers using NG must be connected to a governed meter.
- LPG boilers must be connected to a regulator.
- Installation and connection of the gas supply to the boiler must be in accordance with BS6891.
- Under no circumstances should the size of the gas supply pipe be less than that of the appliance inlet connection.
- The meter or regulator and pipework to the meter must be checked, preferably by the gas supplier, to ensure it is in good working order and can meet the gas flow and pressure requirements in addition to the demand from any other appliance being served. This does not include the pipework from the meter to the boiler.
- For olive connections we recommend using gas pipes with minimum 0.9 mm wall thickness.

S PLAN LAYOUT

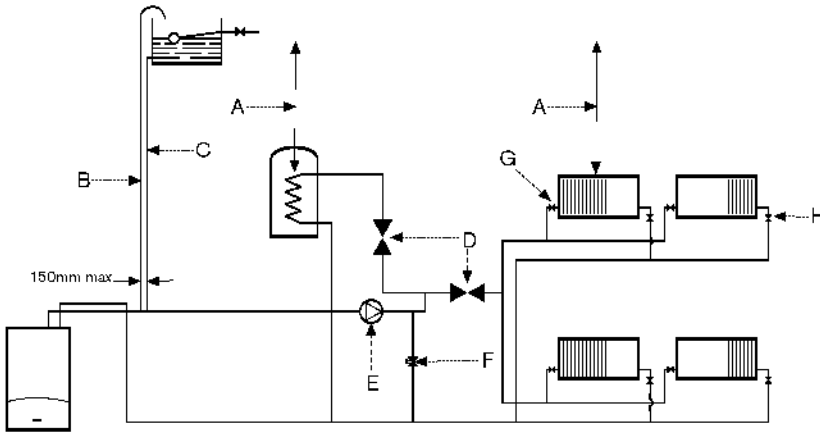

Y PLAN LAYOUT

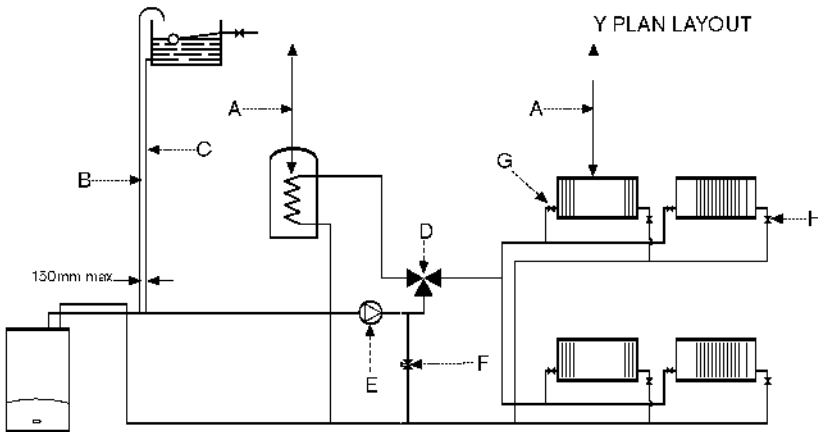

SEALED SYSTEM LAYOUT

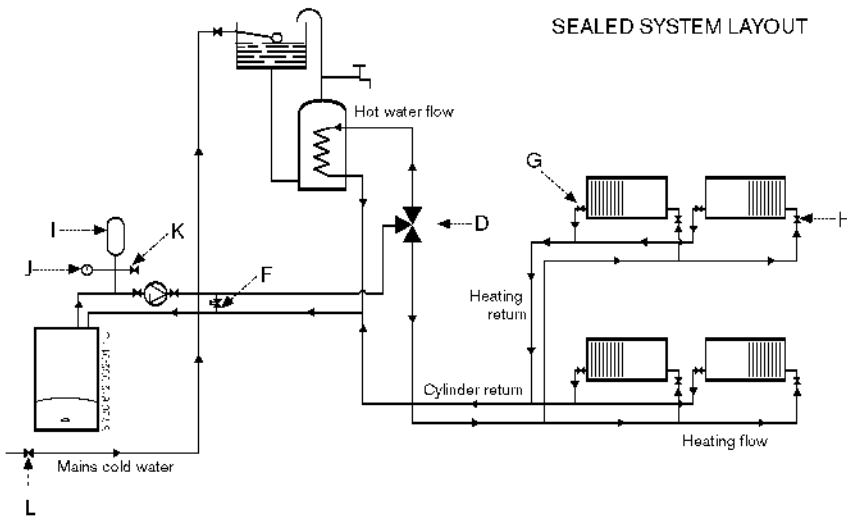

SYSTEM FILL

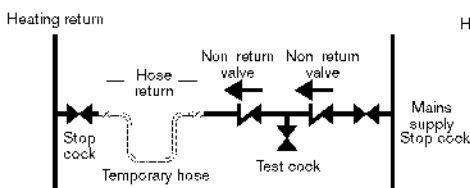

SYSTEM MAKE UP

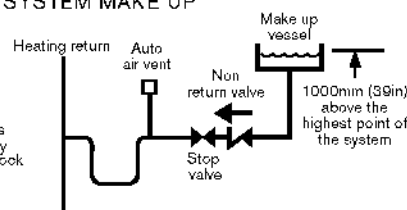

PLASTIC PIPEWORK:

- Any plastic pipework must have a polymeric barrier with 600 mm (minimum) length of copper or steel pipe connected to the boiler.
- Plastic pipework used for underfloor heating must be correctly controlled with a thermostatic blending valve limiting the temperature of the circuits to approx. 50°C. The pipework from the boiler to the blending valve must be in copper or steel (protected from corrosion).

CONNECTIONS/VALVES:

- All system connections, taps and mixing valves must be capable of sustaining a pressure up to 3 bar.
- Radiator valves should conform to BS2767:10.
- Do not use galvanised pipes or radiators.
- All other valves should conform to BS1010.
- On new installations, or extensions to existing systems where a radiator previously did not exist, each radiator should be fitted with a TRV, except the one fitted in the same room/area as the room thermostat.
- On boiler only replacement jobs, it is recommended, (but not mandatory,) to fit a TRV on each radiator. It is, however, a requirement, for energy conservation purposes, to recommend to the customer that a TRV is fitted to each radiator.
- An automatic bypass may be required, (downstream of the pump), in order to maintain the minimum flow-rate through the appliance.
- A drain cock should be fitted at the lowest point of the heating circuit and beneath the appliance.
- An air vent is required at the highest point on the system.

S and Y PLAN SYSTEM:

- A Static Head - Minimum static head 250mm measured from the highest point in the heating system (top surface of the appliance or highest point in the heating system) to the water level in the feed and expansion tank.
- B Heating Vent (22mm minimum)
- C Primary Cold Feed (15mm minimum)
- D Diverter Valve
- E Pump
- F Automatic Bypass
- G Radiator Valve (Flow)
- H Lockshield Valve (Return)

FULLY PUMPED SEALED SYSTEM:

- The sealed system must be filled using a WRAS approved filling loop or comply with the diagram opposite for System fill
- Do not use galvanised pipes or radiators.
- I Expansion Vessel
- J Pressure Gauge
- K Relief Valve
- L Stop Valve Fixed Cylinder Type or sealed systems approved connection

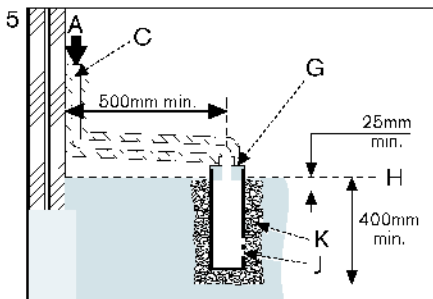
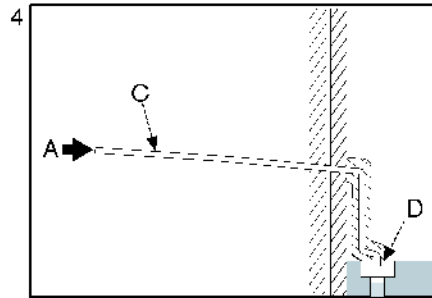
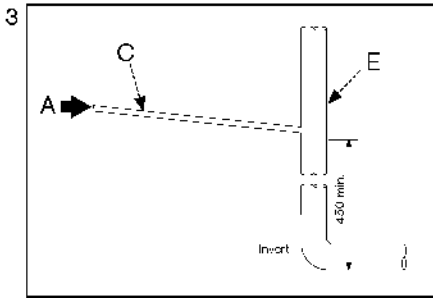
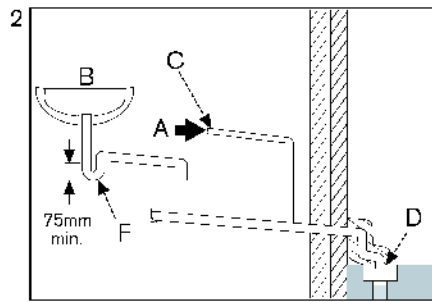
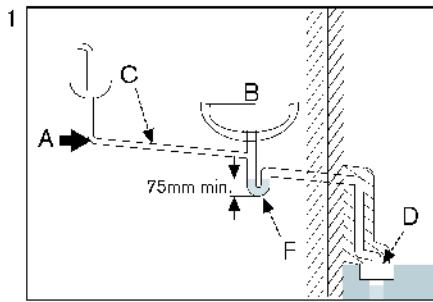

## CONDENSATE PIPEWORK:

- The condensate pipe must be a minimum of 22mmØ plastic pipe.
- **The condensate pipework must fall at least 50 mm per metre towards the outlet and should take the shortest practicable route.**
- The pipework must follow one of the options shown opposite into an internal serviceable-trap (min. 75 mm) such as a sink/washing machine) and discharge direct into a vent stack (E) min. 450 mm above pipe invert or into a gulley (D) below ground but above the water level.
- Wherever possible the condensate discharge pipe work should be routed and terminated internally. Should this not be possible, and the only available route is external, the following conditions should be observed:
  - Pipe work length should be kept to a minimum and the route as vertical as possible.
  - Where pipe work could be subjected to extreme cold or wind chill, a weather proof insulation should be used. Alternatively the condensate pipework could be increased to a minimum 32 mm without the requirement to insulate.

**IMPORTANT: Ensure there are no blockages in the pipe run.**

- 1 Internal sink/washing machine drain
- 2 Internal waste drainage system
- 3 Soil/vent stack
- 4 External drainage system
- 5 External condensate absorption point

- A - Condensate from boiler
- B - Sink
- C - 22 mm Ø plastic condensate pipe
- D - Gulley
- E - Internal soil and vent stack
- F - Serviceable waste trap (75 mm min)
- G - 300 mm x 100 mm Ø sealed plastic tube
- H - Ground level
- J - Drainage holes 50 mm from base of tube (12 mm Ø at 25 mm centres) facing away from building
- K - Limestone chippings

## SERVICING CLEARANCES

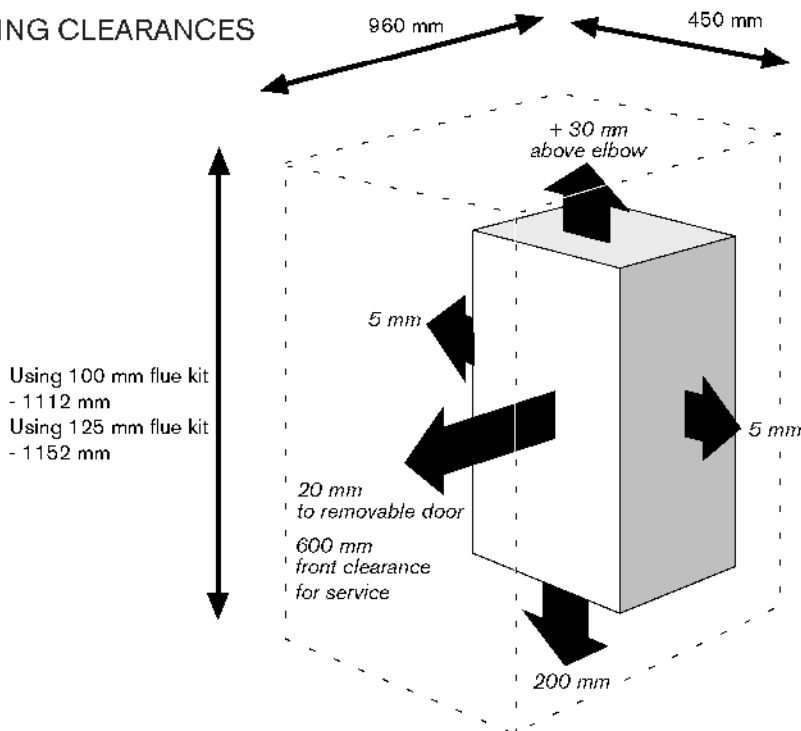

## BOILER LOCATION &

### CLEARANCES

This boiler is only suitable for installing internally within a property at a suitable location onto a fixed, rigid non-combustible surface at least the same size as the boiler and capable of supporting the boiler weight.

#### COMPARTMENTS:

Follow the requirements of BS6798 and BS5440 Part 2 and note:

- Minimum clearances must be maintained
- An access door is required to install, service and maintain the boiler and any ancillary equipment.
- If fitting the boiler into an airing cupboard use a non-combustible perforated material (maximum hole sizes of 13mm) to separate the boiler from the airing space.

#### BOILER CLEARANCES:

The diagram opposite shows the minimum space required to install and service the boiler.

#### VENTILATION

This is a room sealed appliance and does not require any air for combustion from inside the property. If the appliance is fitted into a cupboard or a compartment is built around the appliance after installation, then the compartment must be separated from the boiler space by a perforated non-combustible partition as described in BS 6798.

Notwithstanding the requirements of BS 6798 and BS 5440 there is no need for ventilation openings to be provided in the compartment because of the low heat loss from the appliance casing, if the clearances shown are maintained. Do not operate the appliance if the flue terminal fitted on the outside wall or roof is obstructed or damaged.

CLEARANCES

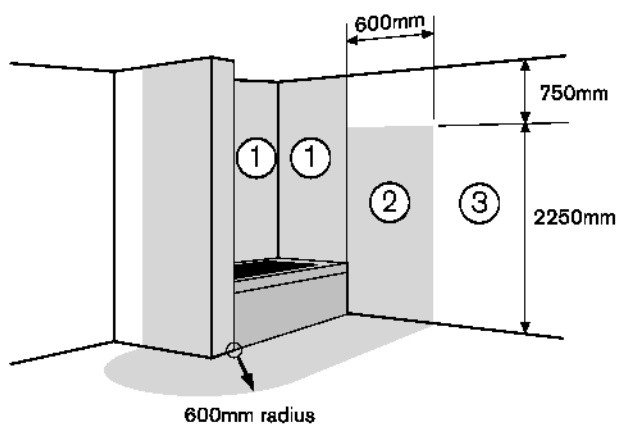
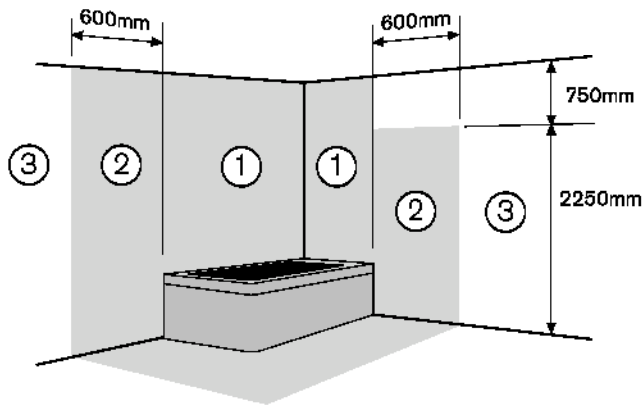

6 720 611 927-15.1 O

BATHROOMS:

The boiler can be installed in zones 2 or 3. If a mechanical or RF mechanical timer is fitted the boiler can only be installed in zone 3. A Non mechanical timer can be installed in zone 2.

See IEE wiring regulations.  
(See *Technical Data* for IP ratings.)

**IMPORTANT:** any switch or appliance control using 230 V mains electricity must not be able to be touched by a person using the bath or shower.

Electrical switches, fused spur and socket outlets must not be situated in the bathroom.

PRE-  
INSTALLATION



Minimum dimensions of flue terminal positions for balanced room sealed flues with fanned draught:

DRWG. REF:	TERMINAL POSITION	DISTANCE
A <sup>1</sup>	Directly below an opening, air brick, opening windows, etc.	300mm
B <sup>1</sup>	Above an opening, air brick, opening window, etc.	300 mm
C	Horizontally to an opening, air brick, opening window, etc.	300 mm
D	Below gutters, soil pipes or drain pipes	75mm
E	Below eaves	200mm
F <sup>2</sup>	Below balconies or car port roof (lowest point)	200mm
G	From a vertical drain pipe or soil pipe	150mm
H	From an internal or external corner	300mm
I	Above ground, roof or balcony	300mm
J	From a surface facing the terminal	600mm
K	From a terminal facing the terminal	1200mm
L <sup>2</sup>	From an opening in the car port (e.g. door, window) into the dwelling	1200mm
M	Vertically from a terminal on the same wall	1500mm
N	Horizontally from a terminal on the same wall	300mm
O	From a non combustible vertical structure on the roof	★
P	Above intersection with roof	★
Q	Adjacent to windows or openings on pitched and flat roofs	600mm
R	Below windows or openings on pitched roofs	2000mm

1 In addition, the terminal should not be nearer than 150mm (fanned draught) to an opening in the building fabric formed for the purpose of accommodating a built-in element such as a window frame.

2 Not recommended.

★ See instructions supplied with vertical flue kits.

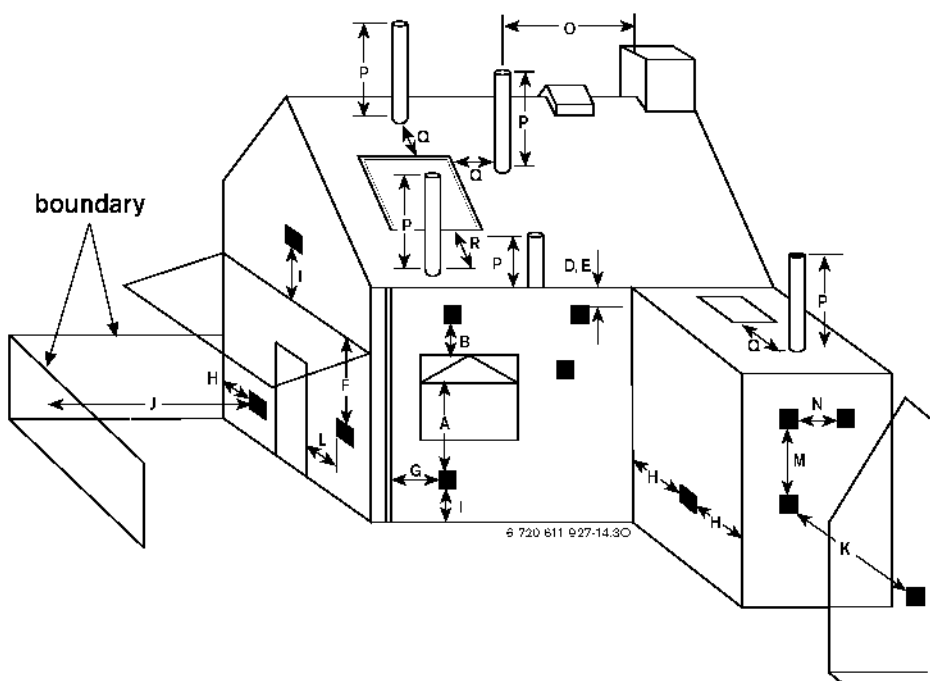

- The flue must be fitted and terminated in accordance with the recommendations of BS5440 : Part 1.
- The flue must not cause an obstruction.
- Discharge and any noise from the flue outlet must not cause a nuisance.
- Flue gases have a tendency to plume and in certain weather conditions a white plume of condensation will be discharged from the flue outlet. Where this could be a nuisance, for example, near security lighting, an alternate position should be found.
- The air inlet/outlet duct and the terminal of the boiler must not be closer than 25mm to any combustible material. Detailed recommendations on protection of combustible materials are given in BS 5440:1
- A protective terminal guard must be fitted if the terminal is 2m or less above a surface to which people have access. The guard must be spaced equally (minimum 50 mm) around the flue and fixed to the wall with plated screws. See Contact Information (inside front cover).

PRE-  
INSTALLATION

STANDARD FLUE HORIZONTAL

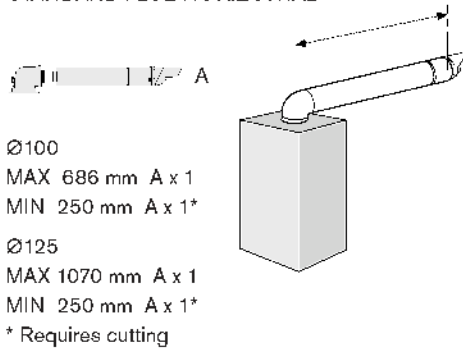

MAXIMUM FLUE VERTICAL  
START + 2 BENDS

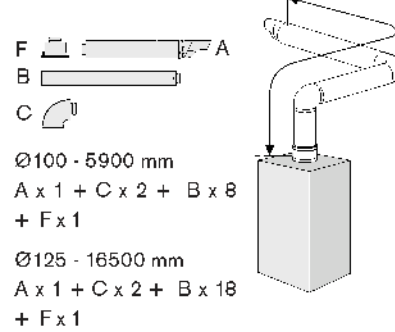

MAXIMUM FLUE HORIZONTAL

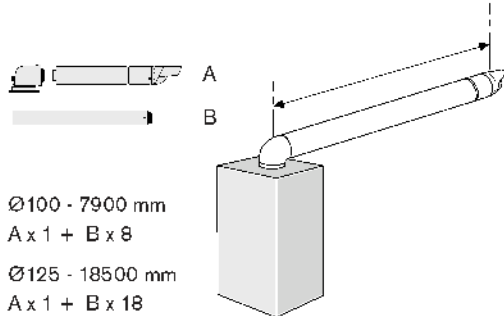

MAXIMUM FLUE VERTICAL  
START + 3 BENDS

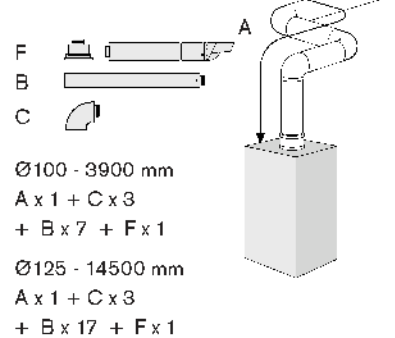

CONVENTIONAL

- The diagrams (opposite) show the components used and the maximum flue length for each configuration of 100 mm and 125 mm  $\varnothing$  flues.
- Shaded flue components indicate the standard 100 mm  $\varnothing$  horizontal flue.
- Only straight flue sections can be reduced in length and cut.
- The flue terminal end can be fitted from the inside or outside of the building.
- Fixing kits are supplied with the flue extension kits.
- Horizontal 125 mm  $\varnothing$  and Vertical 100 mm and 125 mm  $\varnothing$  flue kits are available with separate instructions. Contact your supplier or Worcester Bosch.

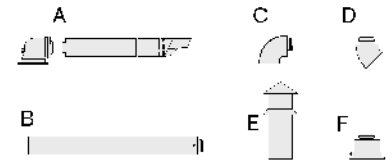

- A - Standard horizontal flue (100 mm  $\varnothing$  shown)
- B - Straight flue extension
- C - Flue bend, 90°
- D - Flue bends, 45°
- E - Vertical terminal (vertical adaptor supplied with terminal)
- F - Vertical adaptor (used with horizontal terminal)

MAXIMUM FLUE VERTICAL START + 1 BEND

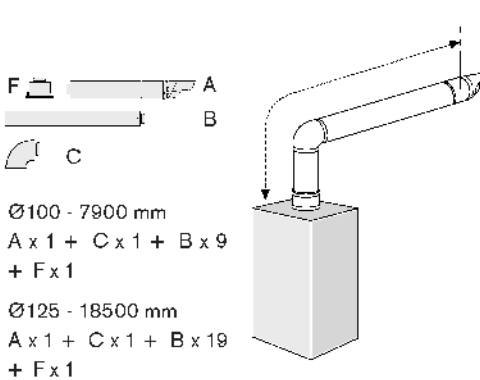

MAXIMUM FLUE VERTICAL  
WITH 2 X 45° BENDS

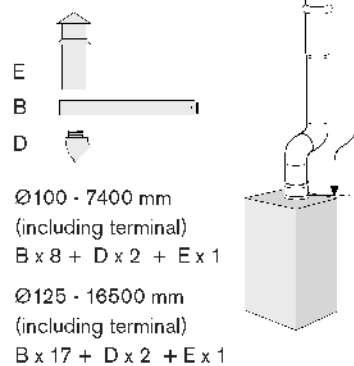

Calculating the flue length:  
 Measure the total flue length required, noting that the maximum straight flue length including the terminal is:  
 Horizontal 60/100 mm  $\varnothing$ : 7900 mm  
 Horizontal 80/125 mm  $\varnothing$ : 18500 mm  
 Vertical 60/100 mm  $\varnothing$ : 9400 mm  
 Vertical 80/125 mm  $\varnothing$ : 18500 mm

Then reduce the total straight flue length for each extra flue bend (excluding the turret) by:  
 2000 mm for 90°  
 1000 mm for 45°

Flue extension total lengths:  
 Horizontal & Vertical 60/100 mm  $\varnothing$ : 960 mm  
 Horizontal & Vertical 80/125 mm  $\varnothing$ : 1000 mm

Flue terminal total lengths:  
 Horizontal 60/100 mm  $\varnothing$ : 800 mm  
 Horizontal 80/125 mm  $\varnothing$ : 1200 mm  
 Vertical 60/100 mm  $\varnothing$ : 1140 mm  
 Vertical 80/125 mm  $\varnothing$ : 1365 mm

MAXIMUM FLUE HORIZONTAL + 1 BEND

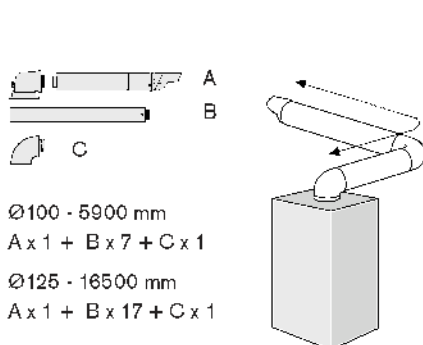

VERTICAL FLUE WITH  
2 X 90° BENDS

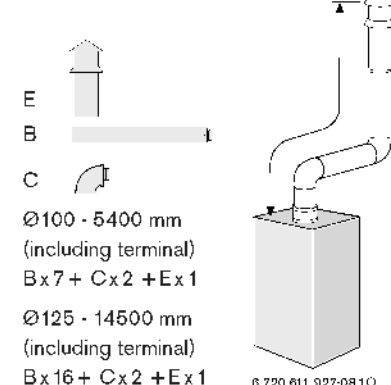

© 720 611 927-08.10

### STANDARD FLUE HORIZONTAL

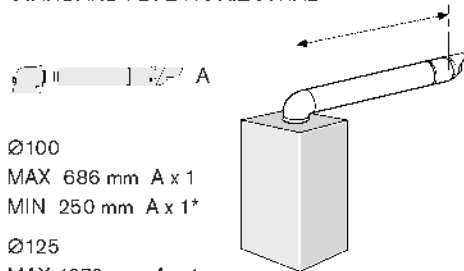

Ø100  
MAX 686 mm A x 1  
MIN 250 mm A x 1\*

Ø125  
MAX 1070 mm A x 1  
MIN 250 mm A x 1\*

\* Requires cutting

### MAXIMUM FLUE VERTICAL START + 2 BENDS

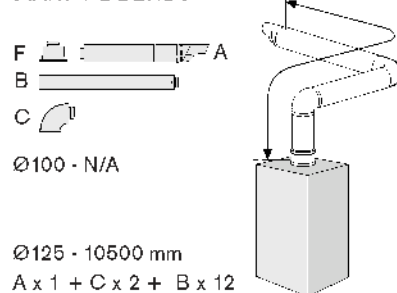

Ø100 - N/A  
 $A x 1 + C x 2 + B x 12 + F x 1$

Ø125 - 10500 mm  
 $A x 1 + C x 2 + B x 12 + F x 1$

### MAXIMUM FLUE HORIZONTAL

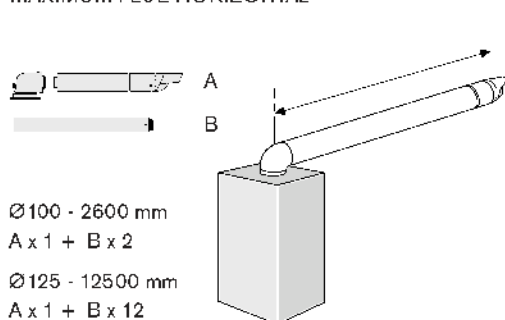

Ø100 - 2600 mm  
 $A x 1 + B x 2$

Ø125 - 12500 mm  
 $A x 1 + B x 12$

### MAXIMUM FLUE VERTICAL START + 3 BENDS

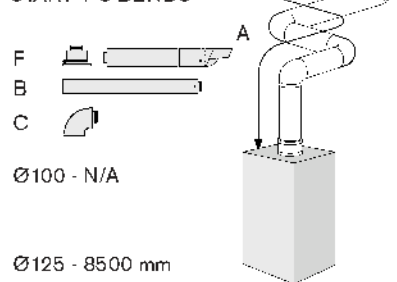

Ø100 - N/A  
 $A x 1 + C x 3 + B x 11 + F x 1$

Ø125 - 8500 mm  
 $A x 1 + C x 3 + B x 11 + F x 1$

### MAXIMUM FLUE VERTICAL START + 1 BEND

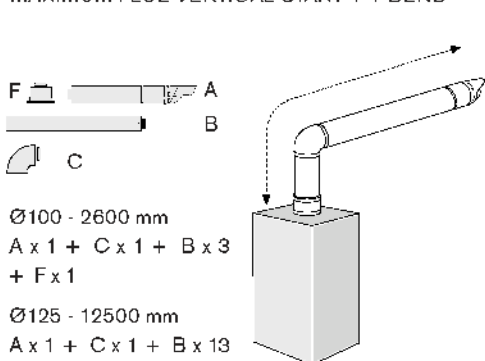

Ø100 - 2600 mm  
 $A x 1 + C x 1 + B x 3 + F x 1$

Ø125 - 12500 mm  
 $A x 1 + C x 1 + B x 13 + F x 1$

### MAXIMUM FLUE VERTICAL WITH 2 X 45° BENDS

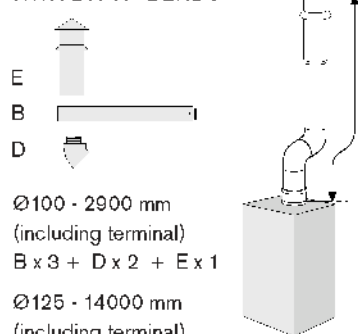

Ø100 - 2900 mm  
(including terminal)  
 $B x 3 + D x 2 + E x 1$

Ø125 - 14000 mm  
(including terminal)  
 $B x 14 + D x 2 + E x 1$

### MAXIMUM FLUE HORIZONTAL + 1 BEND

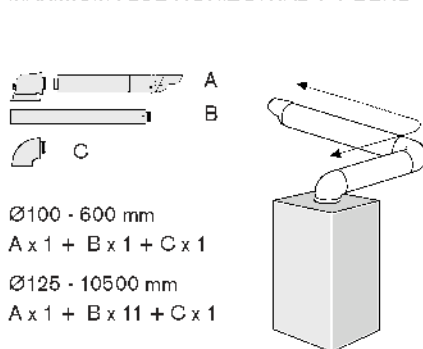

Ø100 - 600 mm  
 $A x 1 + B x 1 + C x 1$

Ø125 - 10500 mm  
 $A x 1 + B x 11 + C x 1$

### VERTICAL FLUE WITH 2 X 90° BENDS

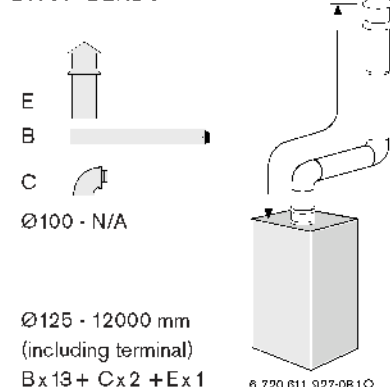

Ø100 - N/A  
 $B x 13 + C x 2 + E x 1$

Ø125 - 12000 mm  
(including terminal)  
 $B x 13 + C x 2 + E x 1$

## FLUE OPTIONS 40CDi

### CONVENTIONAL

- The diagrams (opposite) show the components used and the maximum flue length for each configuration of 100 mm and 125 mm Ø flues.
- Shaded flue components indicate the standard 100 mm Ø horizontal flue.
- Only straight flue sections can be reduced in length and cut.
- The flue terminal end can be fitted from the inside or outside of the building.
- Fixing kits are supplied with the flue extension kits.
- Horizontal 125 mm Ø and Vertical 100 mm and 125 mm Ø flue kits are available with separate instructions. Contact your supplier or Worcester Bosch.

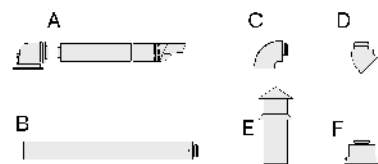

- A - Standard horizontal flue (100 mm Ø shown)
- B - Straight flue extension
- C - Flue bend, 90°
- D - Flue bends, 45°
- E - Vertical terminal (vertical adaptor supplied with terminal)
- F - Vertical adaptor (used with horizontal terminal)

Calculating the flue length:  
Measure the total flue length required, noting that the maximum straight flue length including the terminal is:  
Horizontal 60/100 mm Ø: 2600 mm  
Horizontal 80/125 mm Ø: 12500 mm  
Vertical 60/100 mm Ø: 4900 mm  
Vertical 80/125 mm Ø: 16000 mm

Then reduce the total straight flue length for each extra flue bend (excluding the turret) by:  
2000 mm for 90°  
1000 mm for 45°

Flue extension **total** lengths:  
Horizontal & Vertical 60/100 mm Ø: 960 mm  
Horizontal & Vertical 80/125 mm Ø: 1000 mm

Flue terminal **total** lengths:  
Horizontal 60/100 mm Ø: 800 mm  
Horizontal 80/125 mm Ø: 1200 mm  
Vertical 60/100 mm Ø: 1140 mm  
Vertical 80/125 mm Ø: 1365 mm

**IMPORTANT: All the previous Pre-Installation sections must be read and requirements met before starting boiler or flue installation.**

## UNPACKING WALL FRAME

### AND ANCILLARY ITEMS

#### LIFTING AND CARRYING PRECAUTIONS:

- Lift only a manageable weight, or ask for help.
- When lifting the boiler, bend the knees, and keep the back straight and feet apart.
- Do not lift and twist at the same time.
- Lift and carry the boiler close to the body.
- Wear protective clothing and gloves to protect from any sharp edges.

- A - Carton
- B - Wall mounting plate
- C - Hanging bracket
- D - Hardware pack 1
- E - Hardware pack 2 (gas cock)
- F - Literature pack
- G - Bottom panel
- H - Trap / Syphon Outlet Connection (22 mm Plastic Pipe)
- J - Flow pipe
- K - Return pipe 1
- L - Return pipe 2
- M - Pipework mounting bracket
- N - Gas cock support plate
- O - Braising template
- P - Upper support (polystyrene)
- Q - Carton cover

#### IMPORTANT HANDLING INSTRUCTIONS

- It is advised that two people are used to carry the carton from the van to the point of delivery.
- Once the carton has been delivered, the top of the carton is opened. If a sharp implement is used make sure the carton is not pierced and that the implement is used in such a way so that it may not cause personal injury. All sharp objects must be covered or the blade retracted after use and put away in a safe place.
- ▶ 1. The upper support is now removed with the components (bottom panel, pipework mounting bracket, return pipe 2, gas cock support plate, braising template, fixings, documentation set, hanging bracket). Open the support cover to take the components.
- ▶ 2. The boiler wall mounting plate as well as flow and return pipe 1 can now be pulled out.

#### Additional requirements for roof space installation:

- The boiler should be first unpacked before ascending ladder to loft space.
- Two sets of steps should be used.
- Two people should share the lifting of the boiler up to the loft hatch, where the boiler is entered into the loft space tilted and slid on its back into the loft.

Once the appliance is removed from its packaging check the contents against the packing list. **Before installing appliance ensure system has been cleaned as explained on page 8.**

INSTALLATION

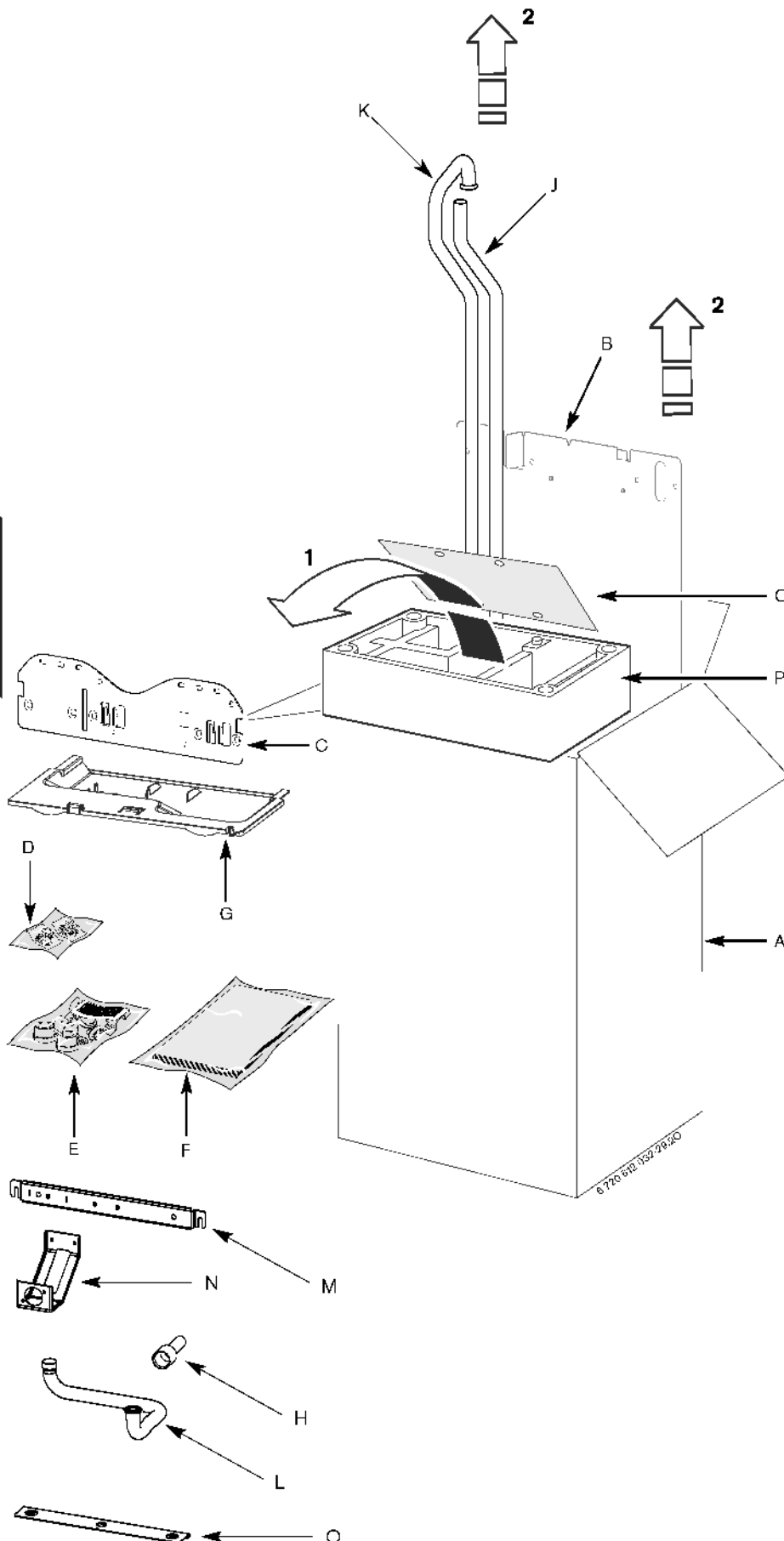

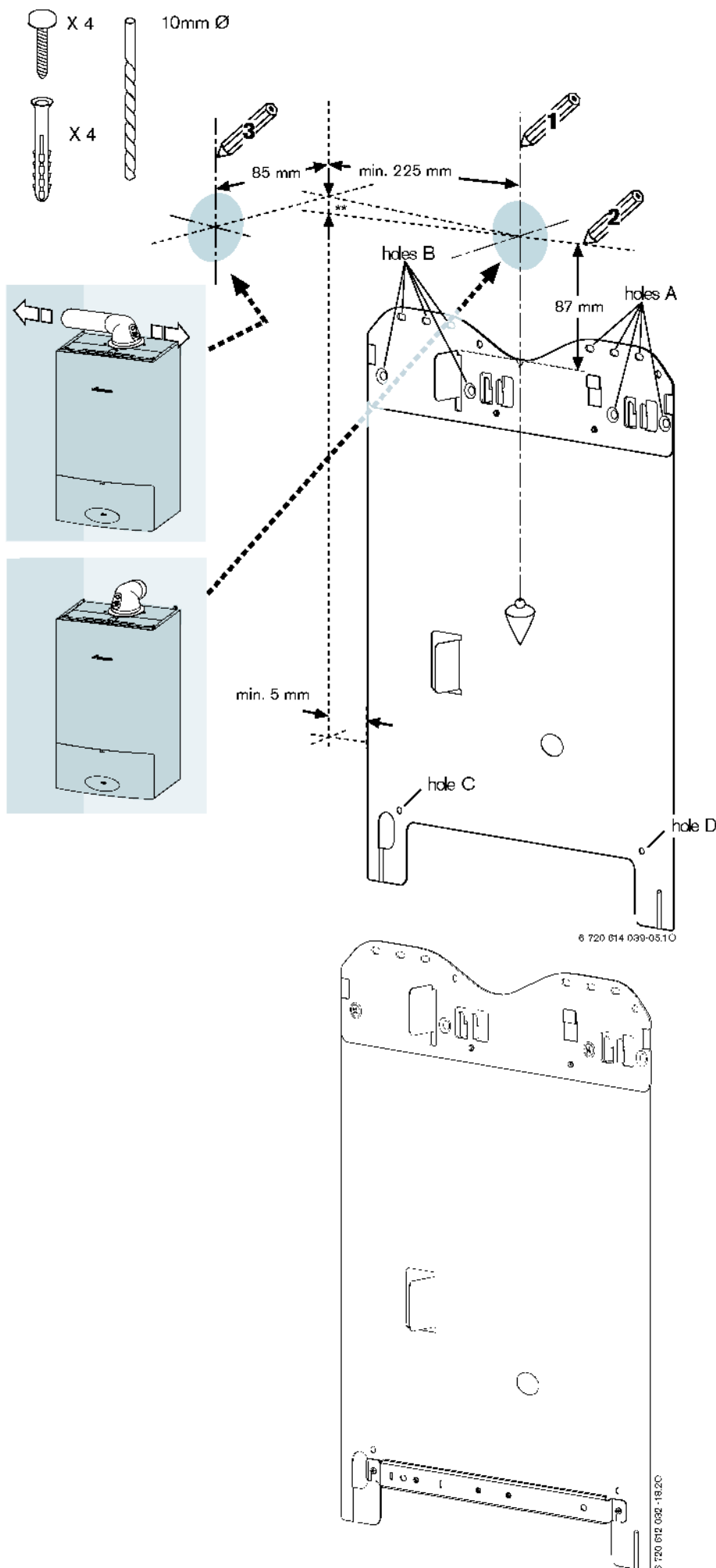

## WALL MOUNTING PLATE

### FLUE OPENING

**CAUTION:** Ensure there are no pipes, electric cables, damp proof courses or other hazards before drilling.

#### SAFETY:

All relevant safety precautions must be undertaken. Protective clothing, footwear, gloves and safety goggles must be worn as appropriate.

#### FIXING THE POSITION OF THE WALL MOUNTING PLATE:

- The diagram opposite shows the relative positions of the flue and the fixing of the wall mounting plate, the mounting plate and pipework mounting bracket.
  - ▶ Place the hanging bracket on the wall mounting plate.
  - ▶ Place the wall mounting plate with hanging bracket against the wall in the desired position.
  - ▶ Mark 4 fixing points through
    - one of the holes A
    - one of the holes B
    - hole C
    - hole D
 in the wall mounting plate/hanging bracket.
  - ▶ Drill the 4 holes for wall mounting plate, wall hanging bracket and pipework mounting bracket.
  - ▶ Secure wall mounting plate with hanging bracket with 4 screws (supplied with the boiler). Do not fully fasten the lower 2 screws.

#### FLUE OUTLET

- ▶ Follow the diagram opposite to mark the centre of the flue for rear outlet (1, & 2) or for side outlet (2 & 3).
  - \*\* Note: increase this height by 52 mm for every 1000 mm of horizontal length that the flue outlet is away from the boiler.
- ▶ For the 60/100 mm Ø flue make a 125 mm diameter hole through the wall using a core drill or similar.
  - For flues using an optional weather collar, fitted from inside the building make a 150 mm Ø hole.
- ▶ Clear away any debris.

#### FIXING THE PIPEWORK MOUNTING BRACKET:

- ▶ Mount the pipework mounting bracket on the 2 lower screws and secure the screws.

INSTALLATION

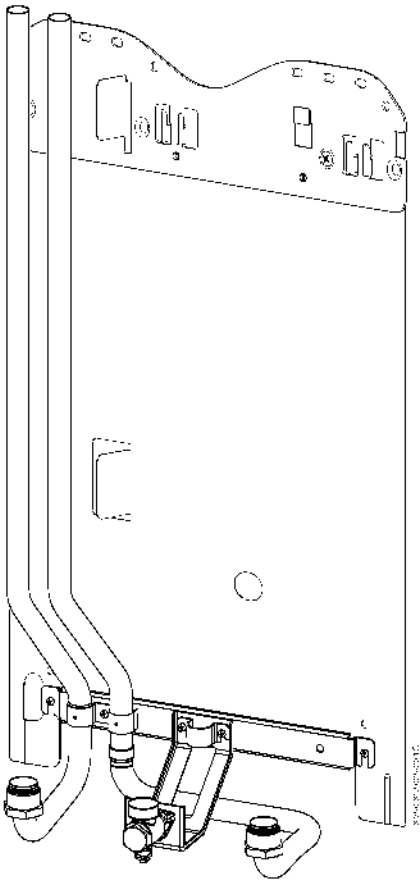

MOUNTING THE PIPES

**Make shure that no sealing washers are mounted while soldering.**

- 1 ▶ Fix the gas cock support plate (N) on the pipework mounting bracket (M) with two screws supplied with the gas cock.
  - ▶ Fix the gas cock on the mounting plate (N)
- 2 ▶ Pull the two nuts on the flow and return pipe.
- 3 ▶ Fix the flow and the return pipe with the bracket.
- 4 ▶ Remove dummy plug from gas cock.
  - ▶ Position braising template (O) on flow pipe and gas cock.
  - ▶ Fix the braising template (O) by pushing the dummy plugs into flow pipe.
  - ▶ Position return pipe 2 and fix it with the dummy plug.
  - ▶ Solder the return pipe.
  - ▶ Remove the dummy plug and the braising template (O).
  - ▶ Replace the dummy plugs to prevent any contamination.

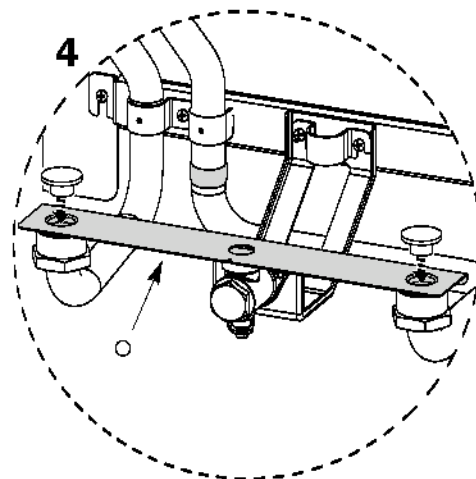
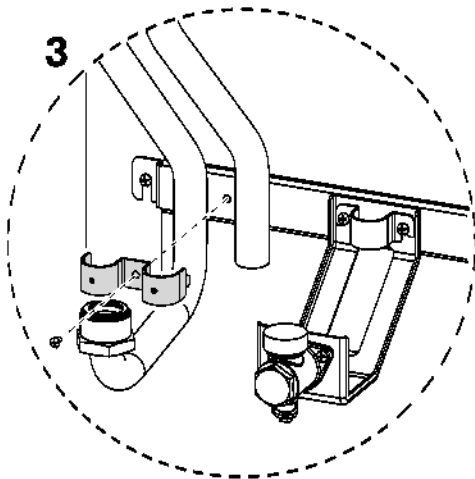
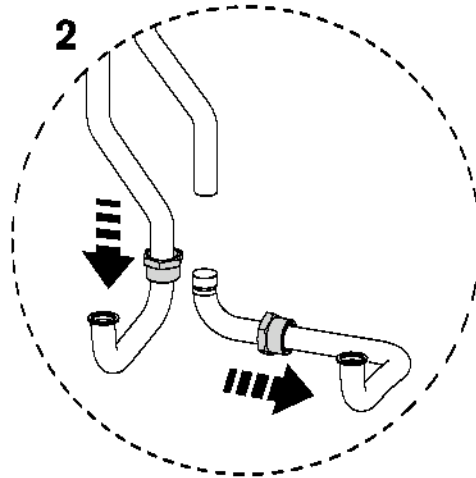
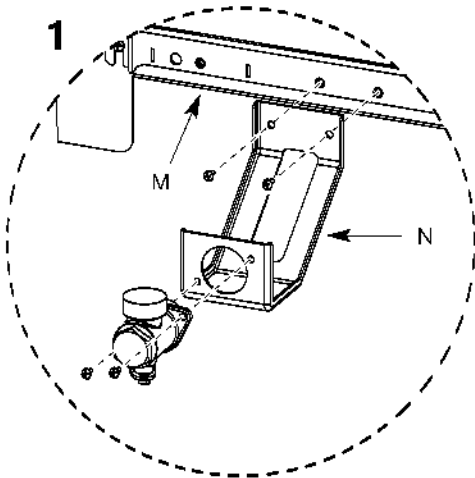

## UNPACKING THE APPLIANCE

### UNPACKING THE APPLIANCE

- A - Outer carton
- B - Packaging base
- C - Protective wrapping
- D - Appliance outer case
- E - Screws
- F - Clip
- G - Protective packaging

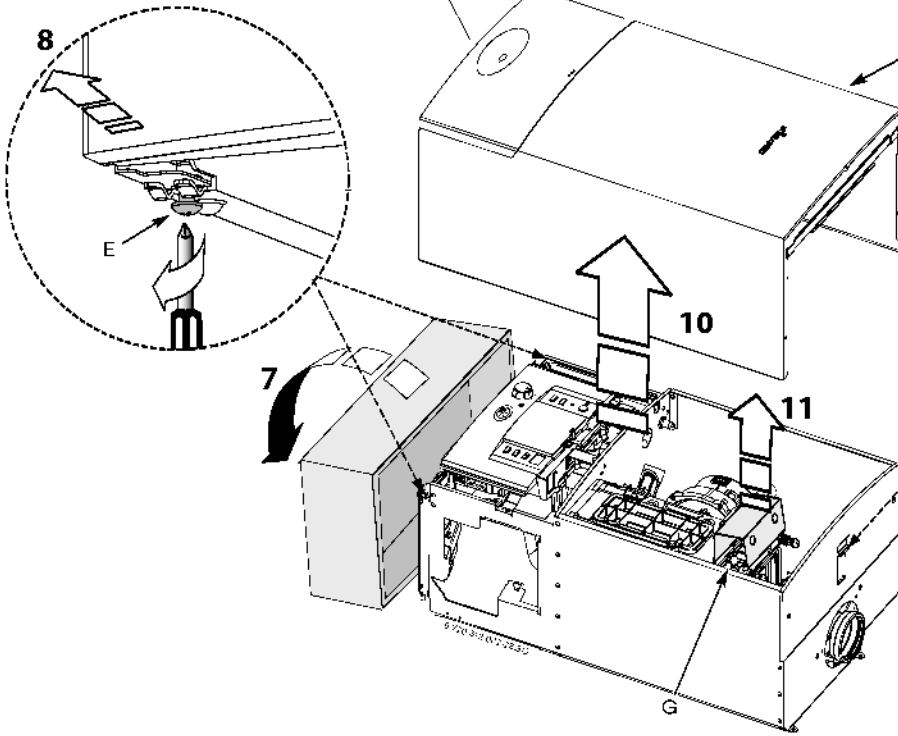
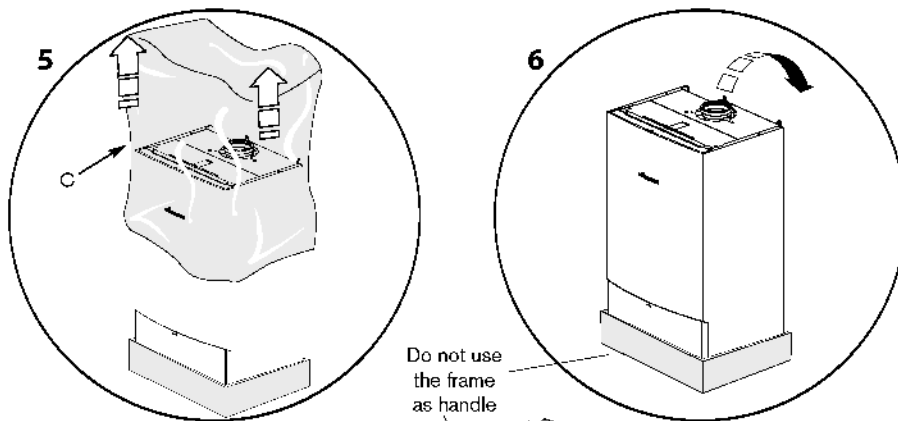
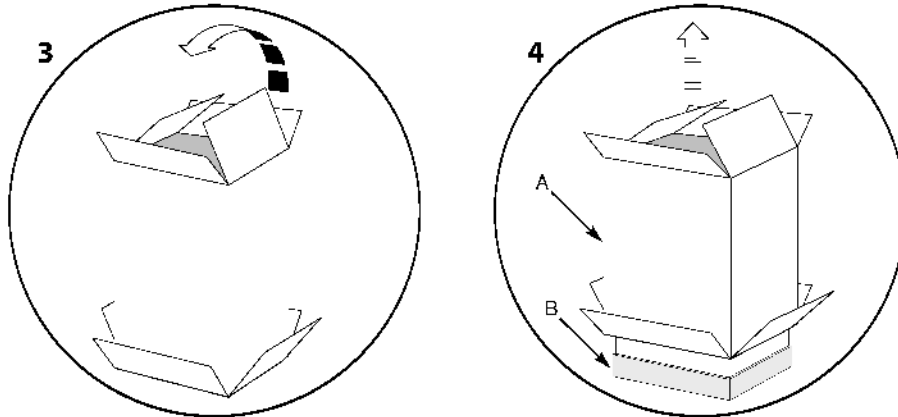
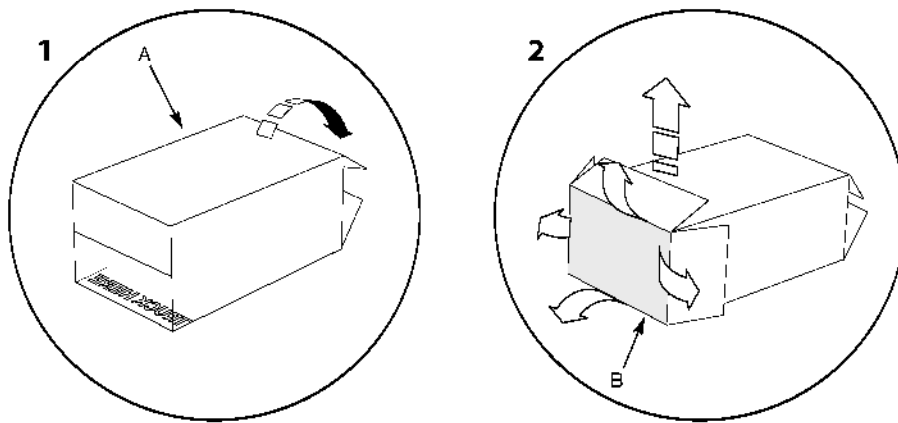

Do not use the frame as handle

- ▶ 1. With the wall frame and ancillary items removed (see page 18), lay the carton (A) on its back.
- ▶ 2. Open the carton bottom flaps and fold under boiler. Do not remove the packaging base.
- ▶ 3. Stand carton (A) with boiler upright on the packaging base (B).
- ▶ 4. Remove outer carton (A) and place safely away from the working area.
- ▶ 5. Remove the protective wrapping (C)
- ▶ 6. Lie the boiler on its back.
- ▶ 7. Remove the packaging base (B) and place safely away from the working area.

### REMOVING OUTER CASE

- ▶ 8. Loosen but do not remove the 2 screws (E) securing boiler casing at the bottom of the appliance.
- ▶ 9. Pull upwards to release the clip (F) on top of the boiler and pull the case upwards.
- ▶ 10. Remove the outer case.
- ▶ 11. Remove the protective packaging (G) from the electrode assembly.

BOILER CONNECTIONS

**CAUTION: ISOLATE THE MAINS GAS SUPPLY BEFORE STARTING ANY WORK AND OBSERVE ALL RELEVANT SAFETY PRECAUTIONS.**

GAS AND WATER CONNECTIONS:

- If there is greater than 600 mm clearance below the appliance it is possible to fit the flow and return pipes, supplied, with the boiler installed on the wall. If clearance is less than 600 mm below the appliance it may be necessary to fit the flow and return pipes before hanging the appliance.
  - ▶ System pipes may be run vertically upwards behind the boiler or below it. See Plumbing Manifold Section on page 14.
- NOTE: If pipes require reducing in length this is best done before they are fitted to the boiler.

- A - Flow (22 mm).
- B - Return (22 mm).
- C - Gas inlet (22 mm).

- ▶ 1. Remove dummy plugs and fit sealing washers before hanging boiler.
- ▶ Remove dust caps from connections on boiler.

NOTE: The accessibility to the gas and water connections can be improved by removing the condensate trap (see also page 40).

- ▶ 2. Hang the boiler on to the hanging bracket. The lugs pass through the rectangular holes in the boiler back panel. Take care not to disturb the washers on the connections.

NOTE: It is recommended that this lifting operation is carried out by 2 people, observing all precautions for the safe lifting of heavy objects.

Do not lift by the top case panel. There are two handling holes incorporated into the inner casing left and right in the lower section of the appliance.

- ▶ 3. Lower the control panel into the service position by removing the screw (X) from the retaining bracket.
- ▶ 4. Make connections to the heating system.
- ▶ Connect the gas supply to the boiler gas cock 22 mm compression.

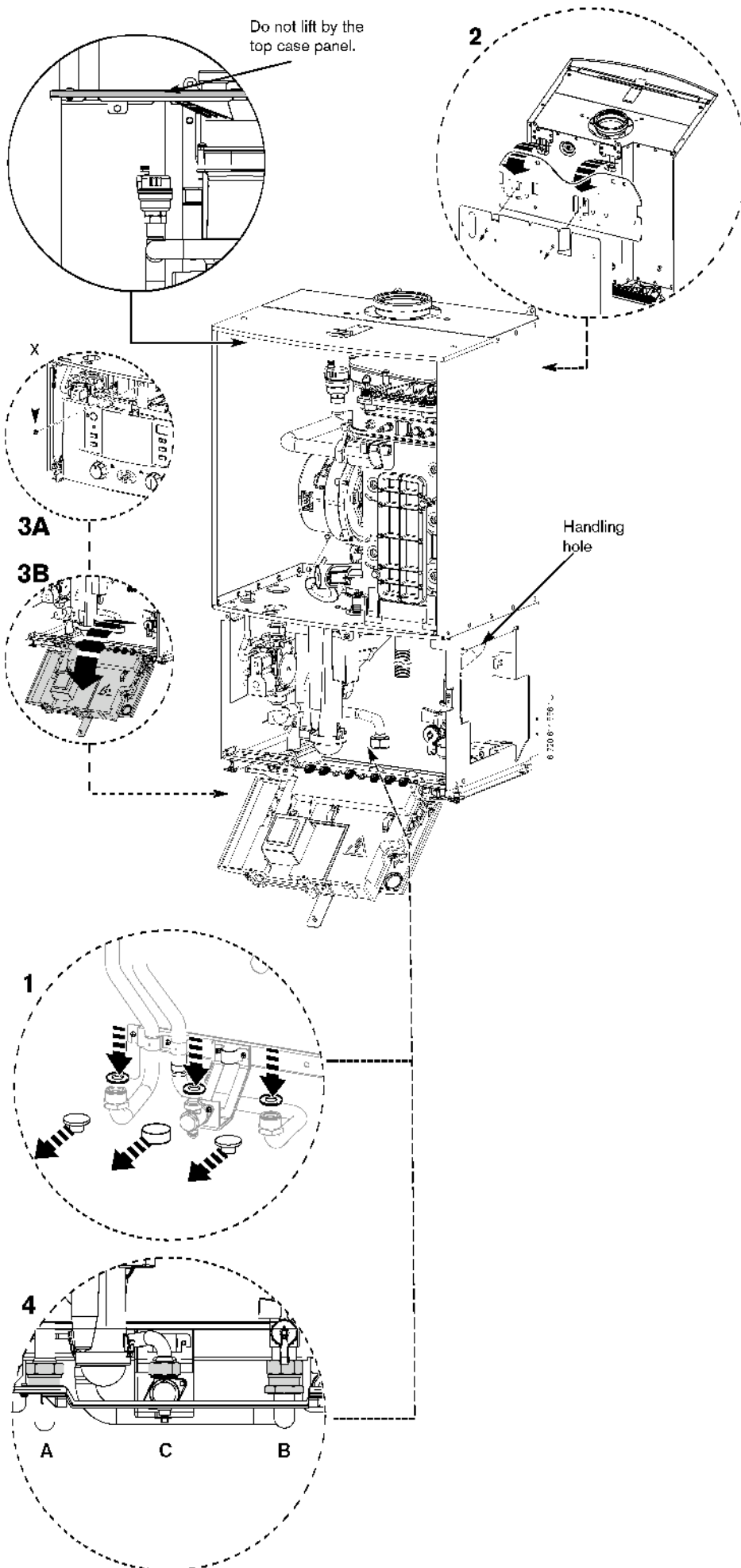

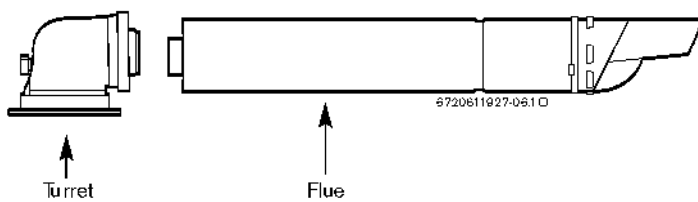
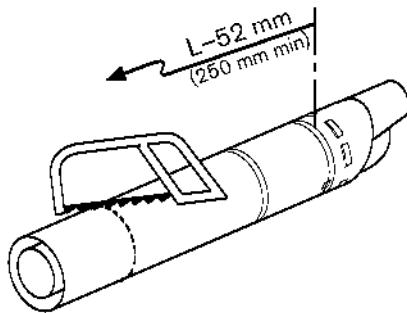
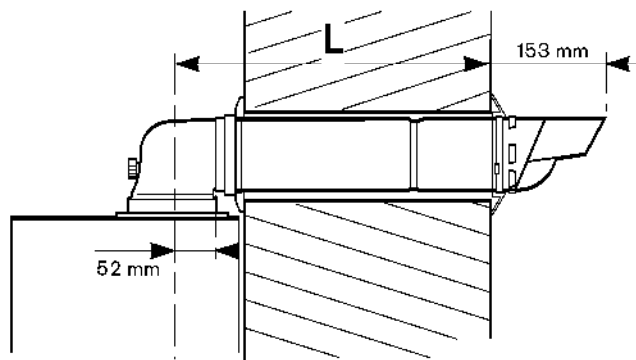
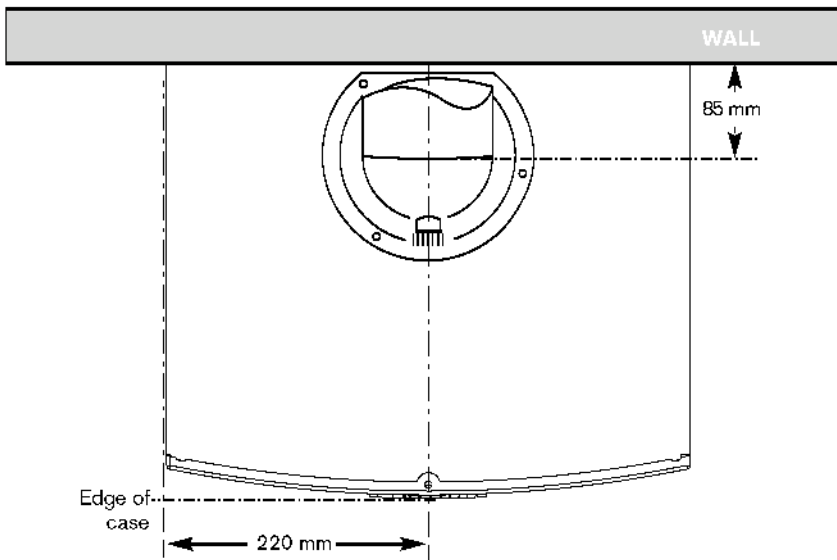

## FLUE INSTALLATION

### HORIZONTAL FLUE (60/100 mm diameter)

For vertical flues and 80/125 mm horizontal flues, please refer to separate Flue Kit instructions.

*NOTE: to ease the assembly of flue components, apply silicone lubricant to sealing surfaces.*

The instructions for the 60/100 mm diameter flue are shown below.

#### MEASURING THE FLUE (Standard Flue):

- ▶ Measure from the outside wall to the centre line of the flue turret (length L).
- ▶ Subtract 52 mm from the length L to give the correct dimension to the flue elbow connection.
- ▶ The terminal section should be cut to this dimension, however it must not be shorter than 250 mm.
- ▶ After cutting the end must be square and free from burrs to prevent damage to the flue seals.

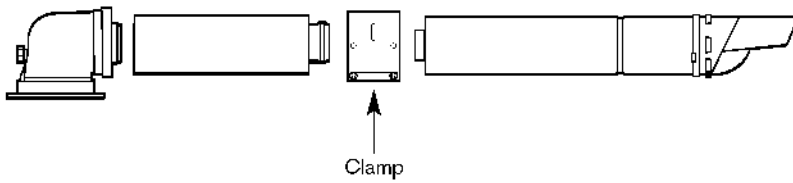

MEASURING THE FLUE (Extension Flue Kits):

**ONLY CUT EXTENDED FLUE LENGTHS**

- ▶ As with the Standard Flue measure from the outside wall to the centre line of the flue turret (length L).
- ▶ Subtract the usable length of the standard flue (634 mm) from length L.
- ▶ Subtract the usable length of the turret (52 mm) from length L.
- ▶ Subtract 960 mm for each full length extension from the figure.
- ▶ Cut one of the extensions to the remainder.
- ▶ Cut both tubes square taking care not to distort the tubes.
- ▶ Remove any burrs.

EXAMPLE:

Length L =	2380 mm
Subtract Standard Flue	- 634 mm
Subtract Turret	- 52 mm
Subtract Full Extension	- 960 mm
Cut Length =	734 mm

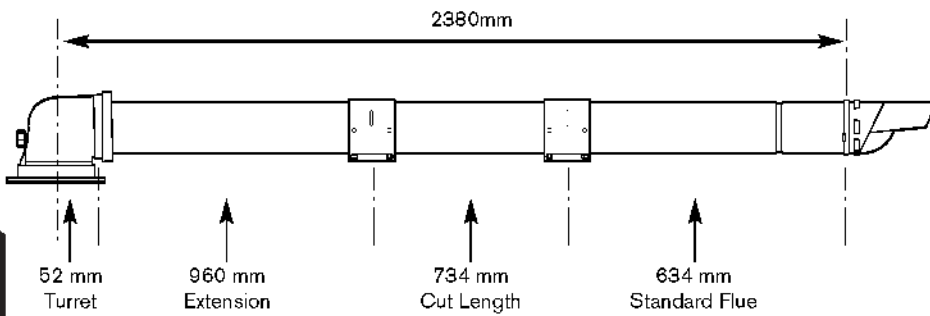

INSTALLATION

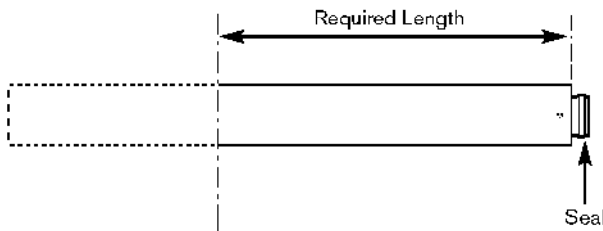

NOTE: Where extensions are reduced, cut length which **DOES NOT** contain the seal.

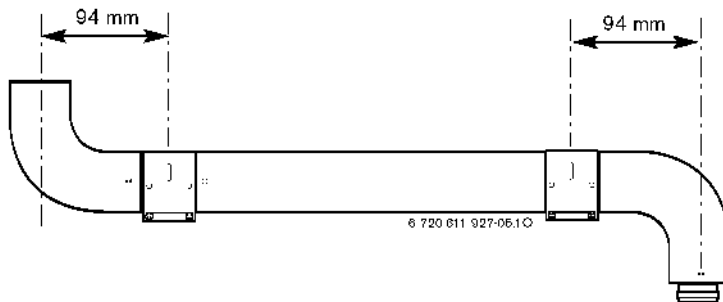

ADDITION OF FLUE BENDS:

When flue bends are being used an allowance of 94 mm per bend must be allowed from the centre line of the bend. In the example shown using a flue extension (960 mm) with 2 bends will achieve a total length of 1148 mm.

- A - Standard Flue
- B - Internal Wall Seal
- C - External Wall Seal
- D - Clamp
- E - Extension Duct

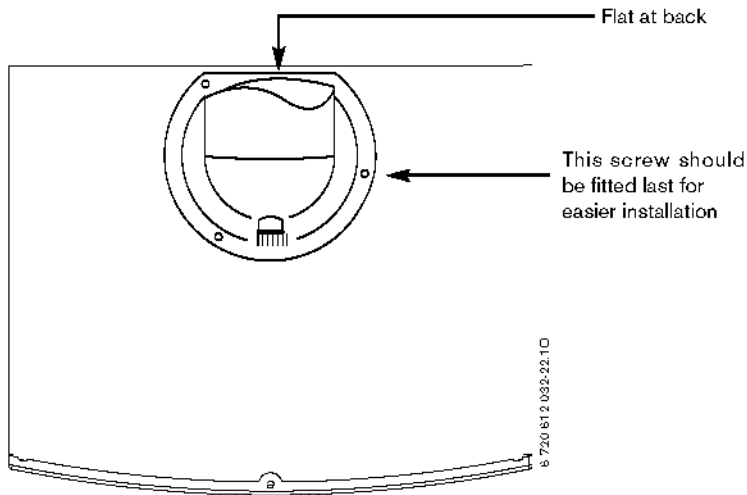
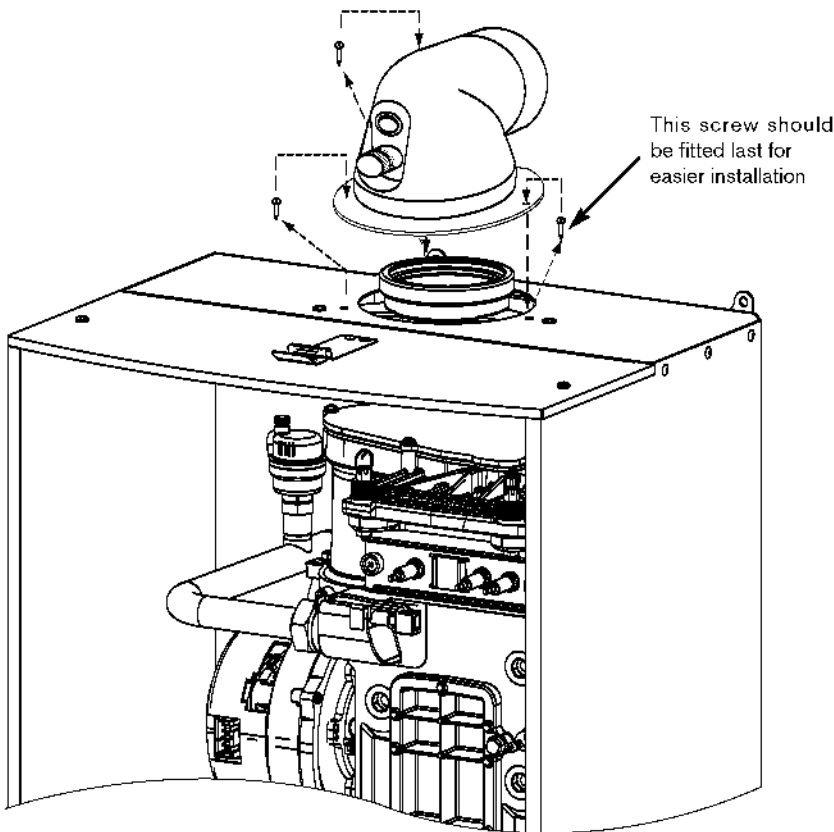
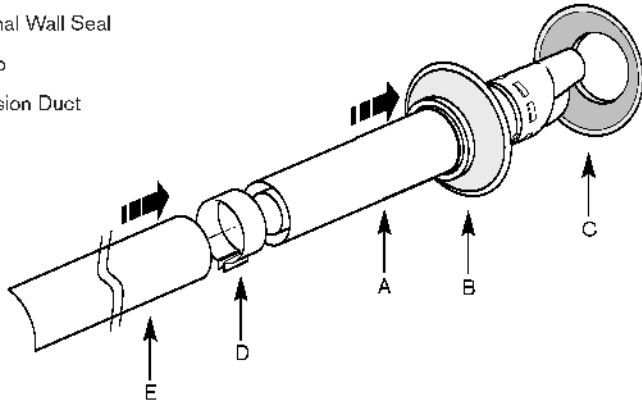

## FLUE INSTALLATION

### ASSEMBLING THE FLUE

- 1 Slide inner collar (B) onto terminal (A)
- 2 Additional extensions or bends:  
Push fit all extensions/bends/terminal together and secure connections with clamps (D). The slope of the terminal outlet must face downwards.

### FITTING THE FLUE

- 3 Fit the terminal (A) through the flue opening in the wall, exposing the plastic outlet section to the outside and fit the outer flue collar (C) over the notches to secure.
- 4 Assemble turret to boiler using the three screws (see below).  
*Note: Screws are in boiler or in flue kit.*

### FITTING THE TURRET:

- Flue turret should push directly down and not be twisted into correct position.
- ▶ Fit turret onto appliance and retain with three screws.  
**NOTE:** The clamping plate flat should be at the rear of the appliance.

### ADDITIONAL NOTES AND REMINDERS:

- Ensure that all cut lengths are square and free from burrs.
- The flue, when assembled, is fully sealed and components are pushed home.
- The flue is set at an angle of 3° or 52 mm per additional 1m length of extension used.

Never terminate or discharge into any open source, including; sink, bath, shower, bidet, toilet etc.

*Note: any external condensate pipework of excessive runs should be protected with weather resistant insulation to help prevent freezing.*

- Ensure that the condensate drain is 22 mm diameter plastic pipe. It must fall at least 50 mm per metre towards the outlet.
- An adapter (A) in 22 mm pipe is contained in the fitting pack.

INSTALLATION

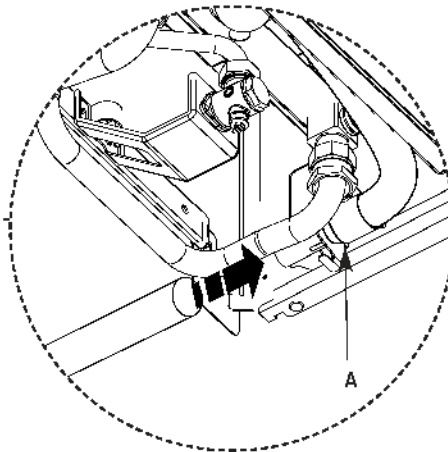
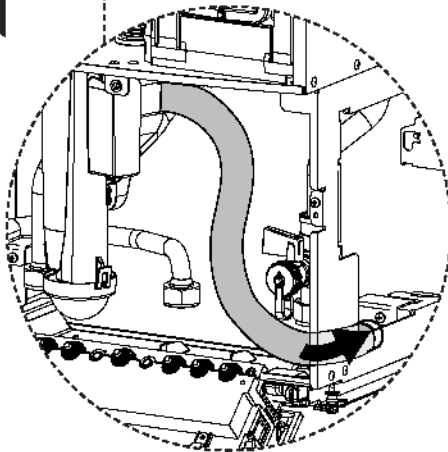
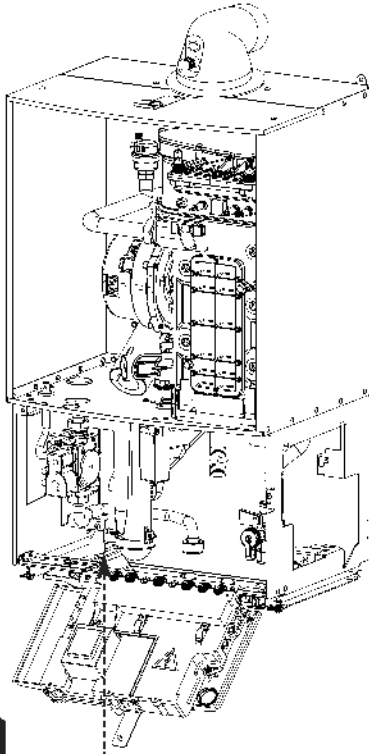

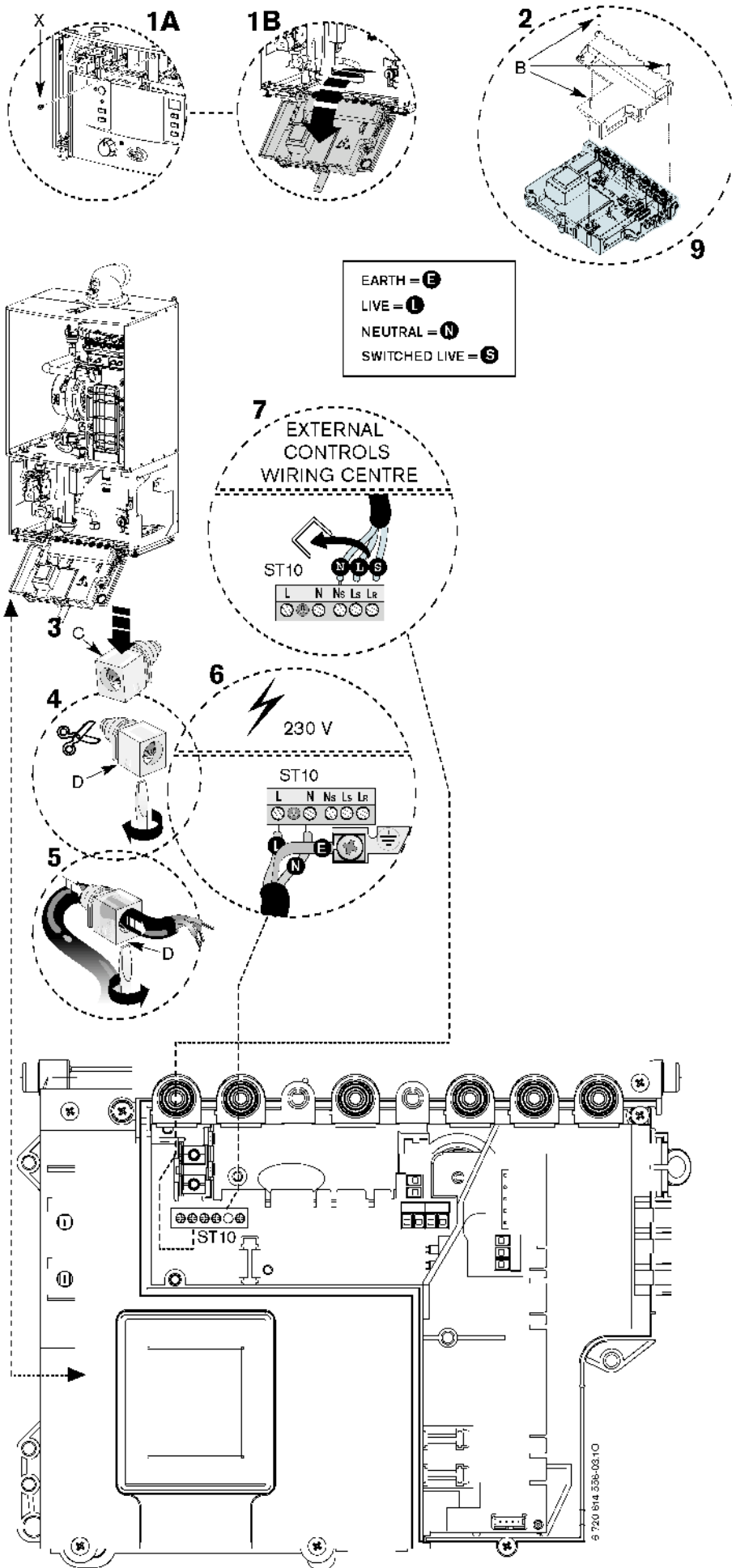

**CAUTION: ISOLATE THE MAINS ELECTRICITY SUPPLY BEFORE STARTING ANY WORK AND OBSERVE ALL RELEVANT SAFETY PRECAUTIONS**

**Danger of short circuit: When connecting the cables ensure that no cable pieces fall into the Heatronic.**

*Note: Mains supply to the boiler must be through a fused double pole isolator situated adjacent to the appliance. The isolator must have a contact separation of 3 mm minimum in all poles.*

Access to electrical connections:

- ▶ Remove boiler casing to access control panel.
- 1. Lower the control panel into the service position by removing the screw (X) from the retaining bracket.
- 2. Unscrew the three screws (B) on the back of the control panel and pull off the connections cover.
- 3. Unclip cable clamp (C).
- 4. Cut off the tapered cable entry to fit cable diameter required.
- 5. Turn cable retaining screw (D) anti-clockwise. Run cable over the main crossbar and through the cable clamp (C), ensuring there is ample cable to reach the connectors. Turn cable clamping screw (D) clockwise to secure cable and replace clamp (C) into control panel.

- 6. Mains power 230 V connection (ST10):
  - ▶ Separate wires from cable end and strip to 6 mm
  - ▶ Connect LIVE wire to terminal (L)
  - ▶ Connect NEUTRAL wire to the terminal (N)
  - ▶ Connect EARTH wire to the earth connector (⏏)

NOTE: Earth cable to be longer so that it pulls out last if mains cable is snagged.

- 7. External controls wiring box (ST10):
  - ▶ Remove link
  - ▶ Connect wiring box LIVE supply to terminal (Ls)
  - ▶ Connect wiring box LIVE return to terminal (LR)
  - ▶ Connect wiring box NEUTRAL to terminal (Ns)

NOTES:

- Description of the wiring box see proprietary instructions.
- Refer to manufacturers instructions when connecting external parts to the wiring centre. Worcester Bosch cannot be held responsible for wiring errors.

INSTALLATION



# POSITION OF WIRED COMPONENTS

INSTALLATION

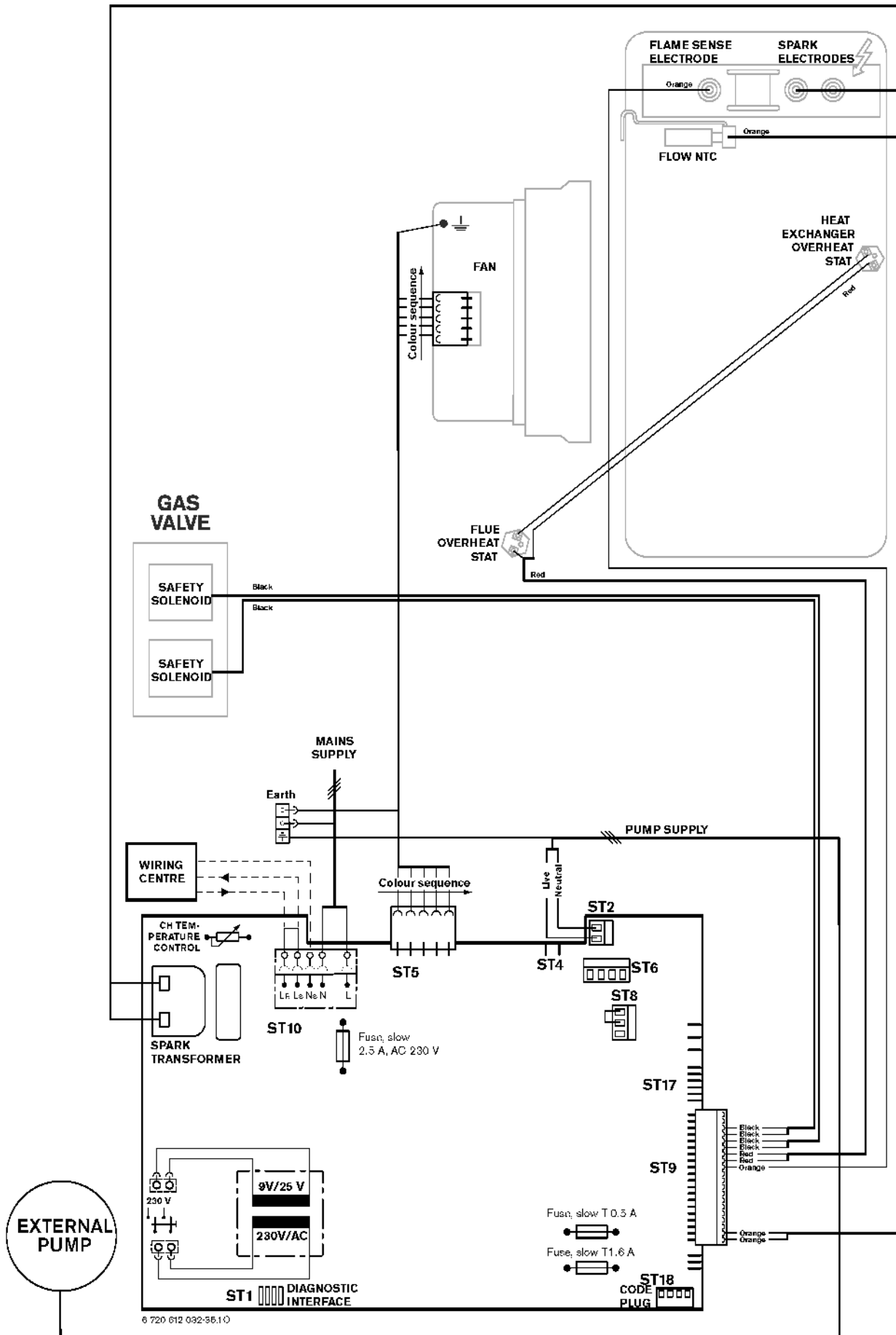

CHECKS

**CAUTION: ISOLATE THE MAINS SUPPLIES BEFORE STARTING ANY WORK AND OBSERVE ALL RELEVANT SAFETY PRECAUTIONS**

- ▶ 1. Check that the service and water pipes are connected to the correct position.

A - Flow (22mm),  
 B - Return (22mm),  
 C - Gas inlet (22mm),

- ▶ 2. Check the gas type specified on the identification plate (F) matches that of the gas supply. Turn on the main gas supply, check the gas pipework, connections and rectify any leaks.
- ▶ 3. Check that the condensate pipe has been connected to the adapter.

**IMPORTANT:** If the boiler is not to be commissioned immediately then: after successfully completing all of the checks and any rectification work, close the gas and water valves, shut off the gas supply and electrically isolate the boiler.

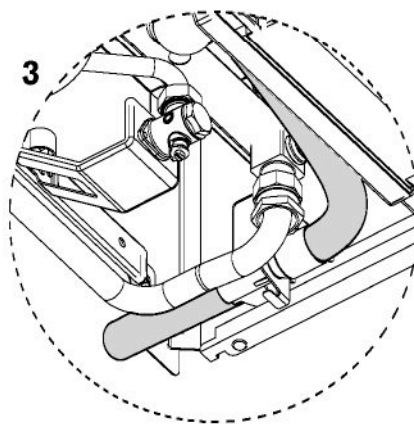
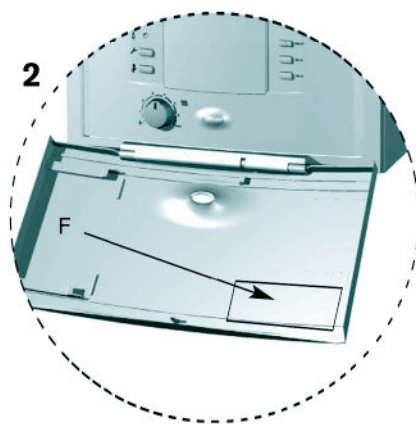
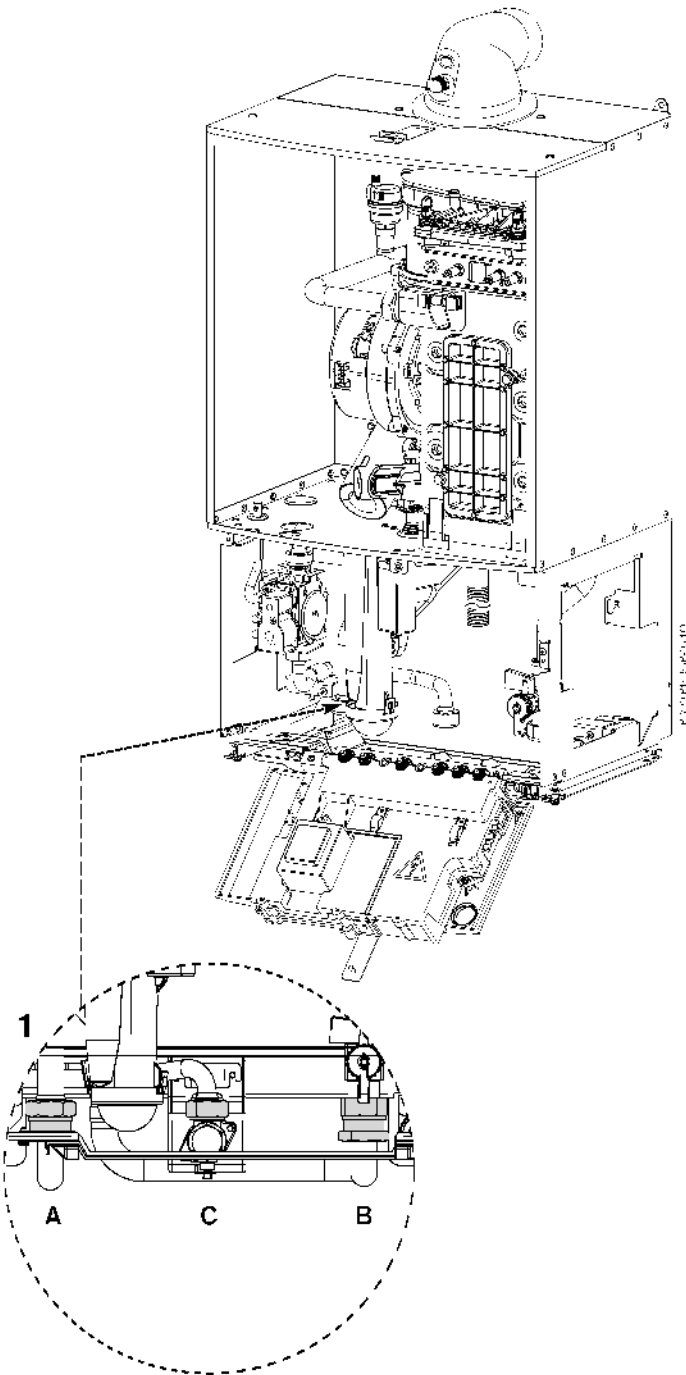

## FILLING THE SYSTEM

- 1 Ensure all system and boiler drain points are closed.
- 2 For sealed systems fill the system using a WRAS approved filling loop to a pressure of 1 bar.
- 3 Vent all radiators and primary side of the hot water cylinder.
- 4 Refill the system up to 1 bar.

### GAS SUPPLY

- ▶ Open gas cock on the boiler and purge the gas supply to the boiler ensuring that the room is well ventilated.
- ▶ Test gas supply for soundness as described in BS 6891.

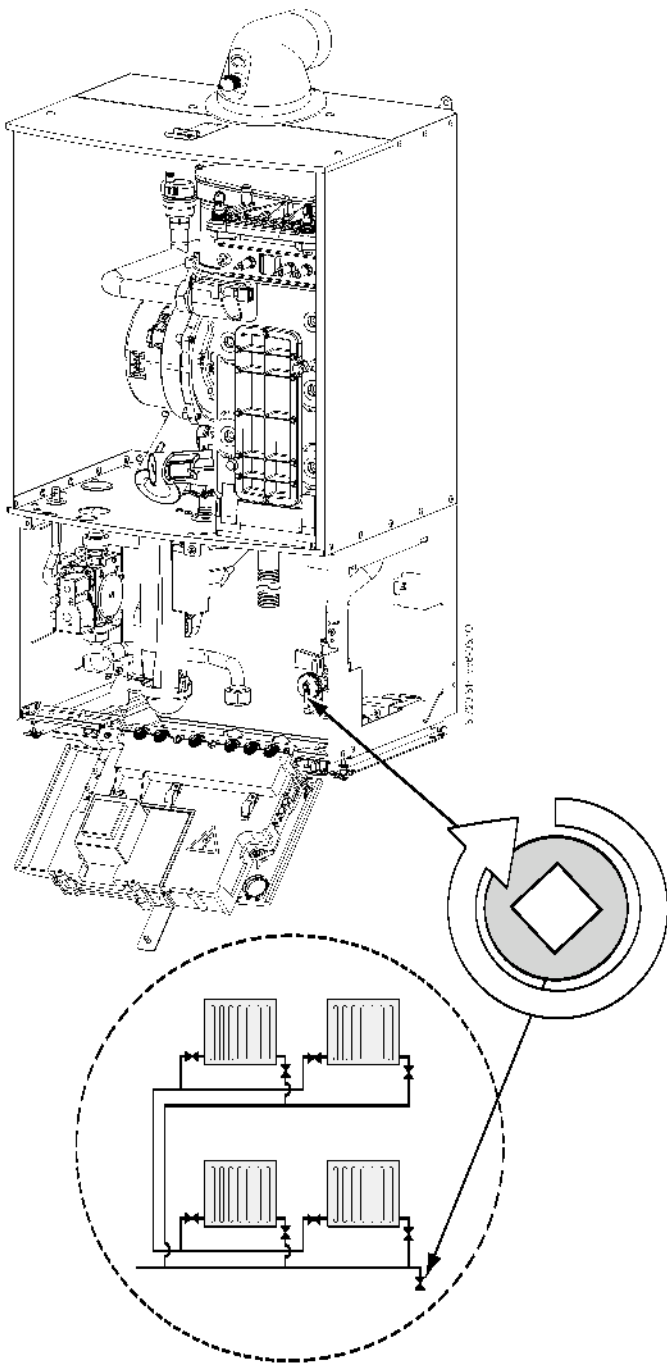



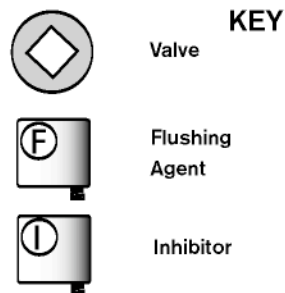
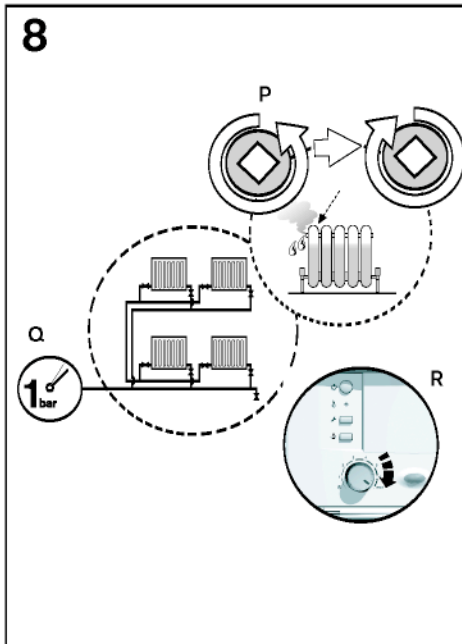
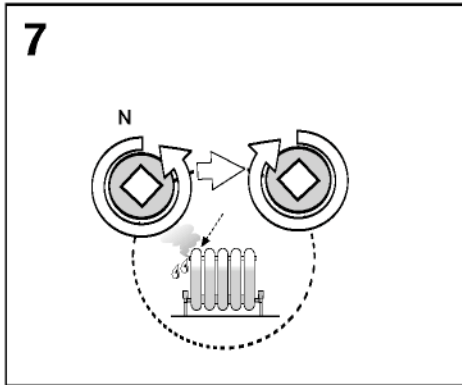
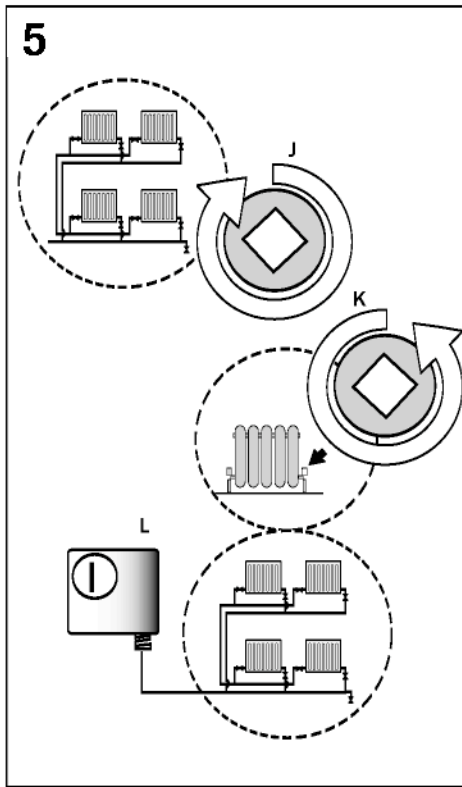
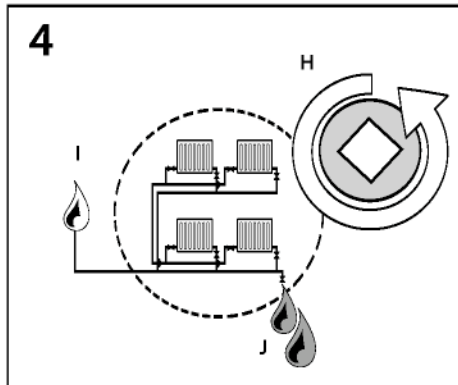
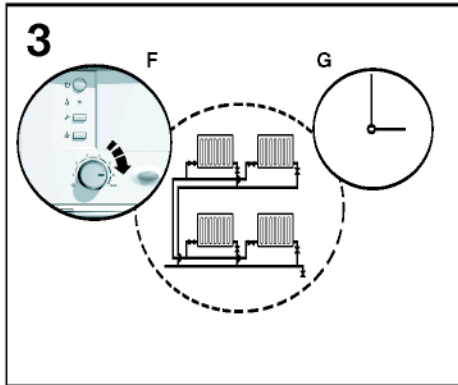
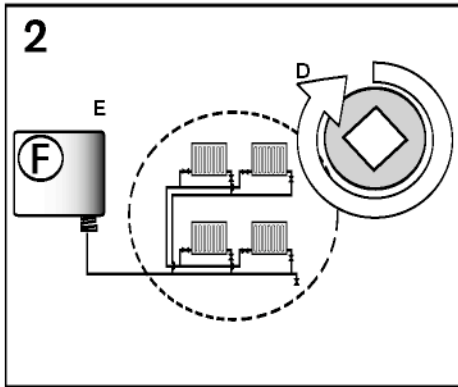
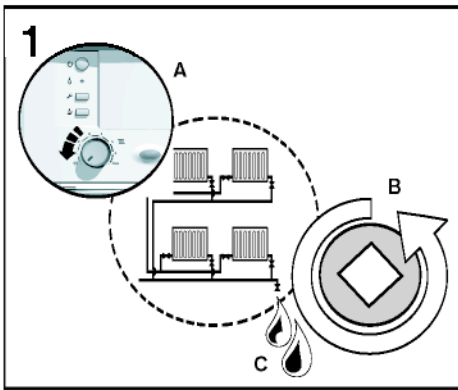

6 720 612 032-06.1O

**IMPORTANT:** Debris from the system can damage the boiler and reduce efficiency. Failure to comply with the guidelines for the use of water treatment with the appliance will invalidate the appliance warranty.

ENSURE THAT THE SYSTEM HAS BEEN CLEANED AS ON PAGE 8 OF THESE INSTRUCTIONS.

**FLUSHING (Central Heating):**

1. ▶ Switch off the boiler (A).
  - ▶ Open all drain cocks (B) and drain the system (C) while the appliance is hot.
2. ▶ Close drain cocks (D) and add a suitable flushing agent (E) at the correct strength for the system condition in accordance with the manufacturer's instructions.
3. ▶ Run the boiler/system at normal operating temperature (F) for the time stated by the manufacturer of the flushing agent (G).
4. ▶ Drain (H) and thoroughly flush the system to remove the flushing agent and debris (I).

**INHIBITOR (Central Heating):**

5. ▶ Check drain cocks are closed (J) and all radiator valves are open (K) before adding a suitable\* inhibitor (or combined inhibitor/anti-freeze if the system is exposed to freezing conditions) to the heating system water (L) in accordance with the manufacturers instructions.
6. Fill via a WRAS approved filling loop to between 1 and 2 bar.
7. ▶ Vent all radiators; re-tighten vents when complete (N).
8. Vent the primary side of the hot water tank (P).
  - ▶ For sealed systems re-pressurise if necessary (Q).
  - ▶ Set all controls to maximum (R).
  - ▶ Record the date when the inhibitor was added to the system on the guarantee card.

*NOTE: The concentration level of inhibitor in the system should be checked every 12 months or sooner if system content is lost.*

*The addition of sealing agents to the system water is not recommended as this can cause problems with deposits left in the heat exchanger.*

\* compatible with aluminium. The pH value of the system water must be less than 8 or the appliance guarantee will be invalidated.



## FINISHING COMMISSIONING

The boiler has been factory set, so there should be no need to adjust combustion settings.

### REPLACE OUTER CASING:

- 1 Replace outer casing making sure that the securing points are properly located.
  - ▶ Press the clip (A) downwards to secure casing on top.
  - ▶ Retighten bottom two screws (B).

### INSTALLING BOTTOM PANEL:

- 2 The bottom panel slides onto two ledges (C) either side of the boiler frame.
  - ▶ Hold the panel up against the underside of the boiler and slide towards the rear until it is fully engaged.

### HANDOVER:

- ▶ Complete the Benchmark check list.
- ▶ Open the fascia cover by gently pressing the centre top of the cover (D).
- ▶ Set up the controls and show the user how to operate all the controls shown in the User Guide.
- ▶ Place the user guide into the tray (E) on the inside of the fascia cover.
- ▶ If the appliance is unused and exposed to freezing conditions; shut off all the mains supplies and drain the system and boiler.

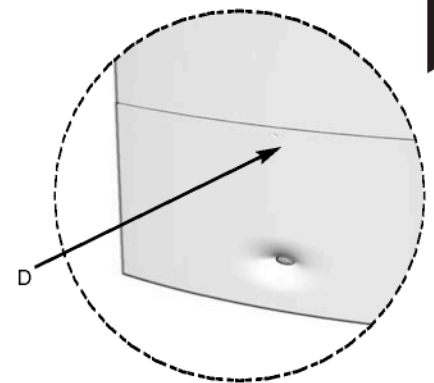
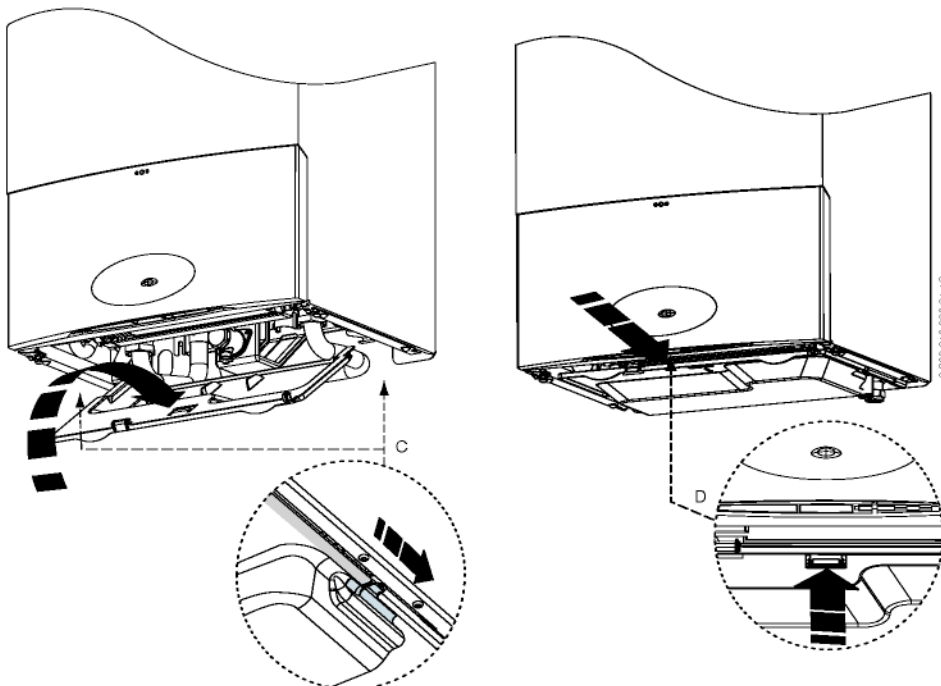
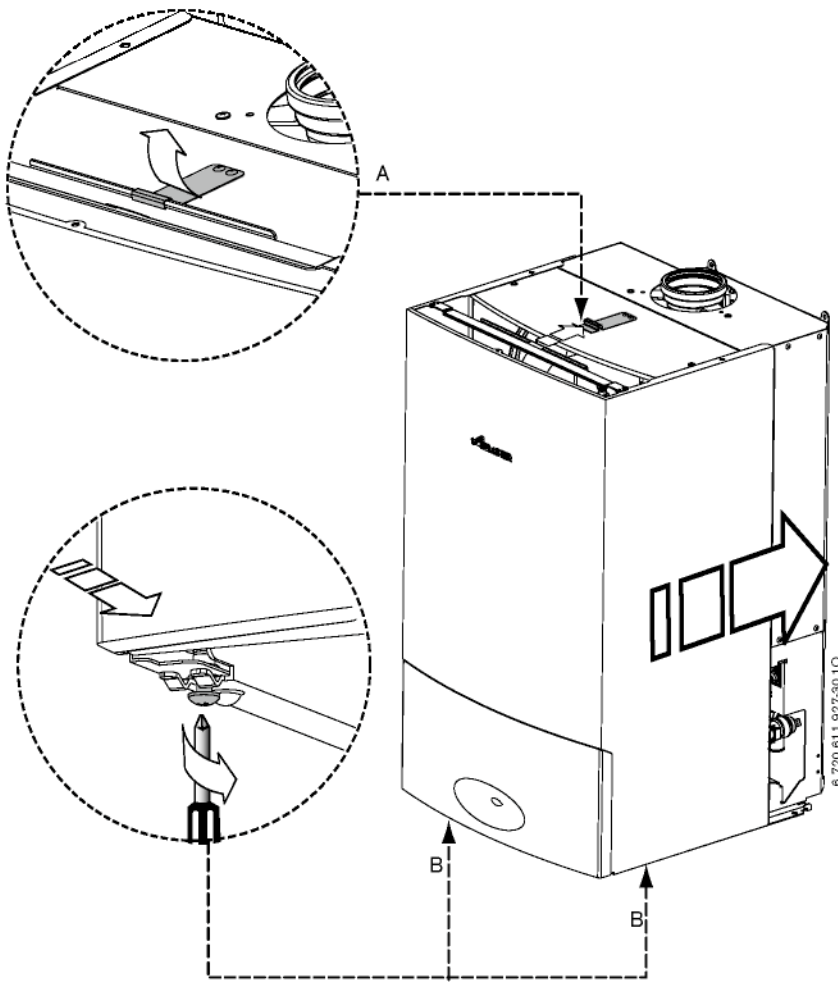

**CAUTION:** TURN OFF THE GAS SUPPLY AND ISOLATE THE MAINS SUPPLIES BEFORE STARTING ANY WORK AND OBSERVE ALL RELEVANT SAFETY PRECAUTIONS.

**IMPORTANT:** AFTER REPLACEMENT OF ANY COMPONENTS ALWAYS CHECK FOR GAS SOUNDNESS WHERE RELEVANT AND CARRY OUT FUNCTIONAL CHECKS AS DESCRIBED IN COMMISSIONING. ANY O-RING OR GASKET THAT APPEARS DAMAGED MUST BE REPLACED.

INSPECTION AND SERVICE

**IMPORTANT:** Any service work must be carried out by competent registered engineers such as British Gas or Corgi registered engineer.

- To ensure the continued efficient operation of the appliance it must be checked at regular intervals.
- The frequency of servicing will depend upon the particular installation conditions and usage. However, an annual service is recommended.
- The extent of the service required by the appliance is determined by the operating condition of the appliance when tested by fully qualified engineers.

INSPECTION

1. Check that the terminal and the terminal guard, if fitted, are clear and undamaged.
2. If the appliance is in a compartment or cupboard check that the specified service space around the appliance is clear.
3. Check all the joints and connections in the system and remake any that show signs of leakage. Refill and re-pressurise if applicable as described in Commissioning.
  - ▶ Operate the appliance and take note of any irregularities. Call up the last fault stored by the Bosch Heatronic, Service Function .0. Refer to Fault Finding for rectification procedures.

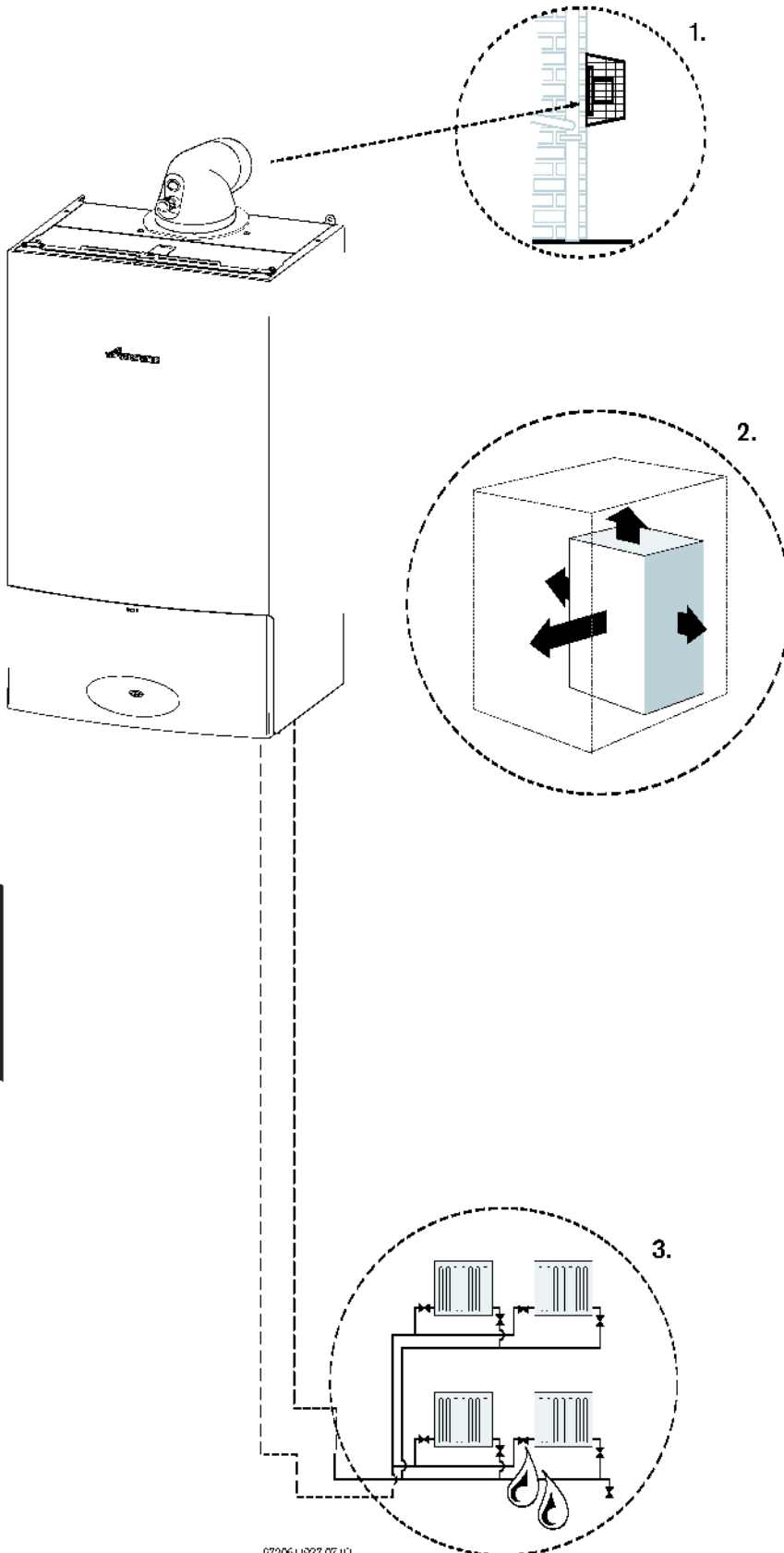

0720611927 07.10

COMPONENT ACCESS

**1. Removing outer case**

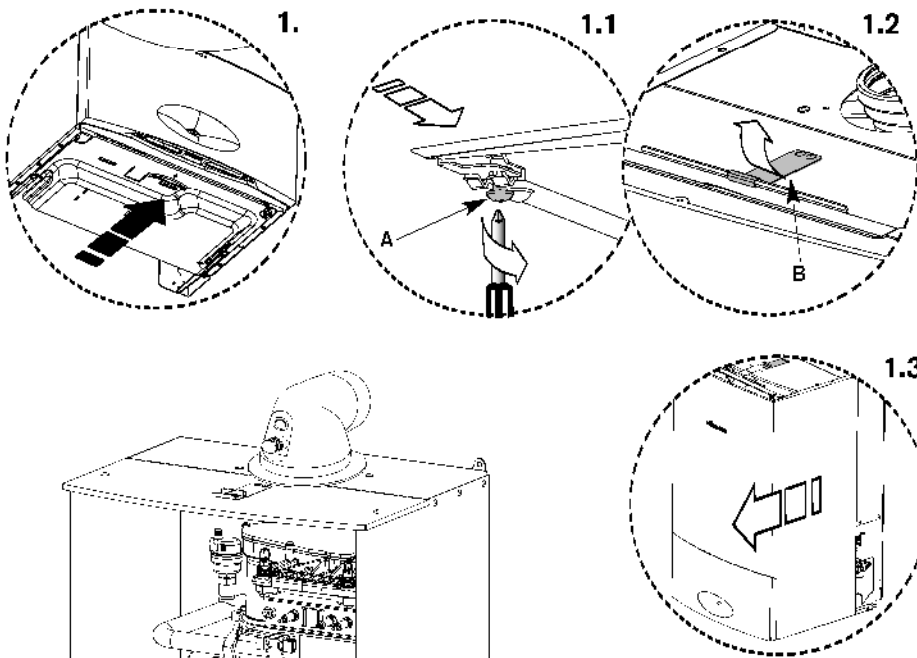

1. Remove bottom panel by pulling it forward and off.
- 1.1 Undo but do not remove the 2 screws (A) securing boiler casing at the bottom of the appliance.
- 1.2 Pull upwards to release the clip (B) on top of the boiler.
- 1.3 Pull case forward and remove.

**2. Adjusting boiler control to service position**

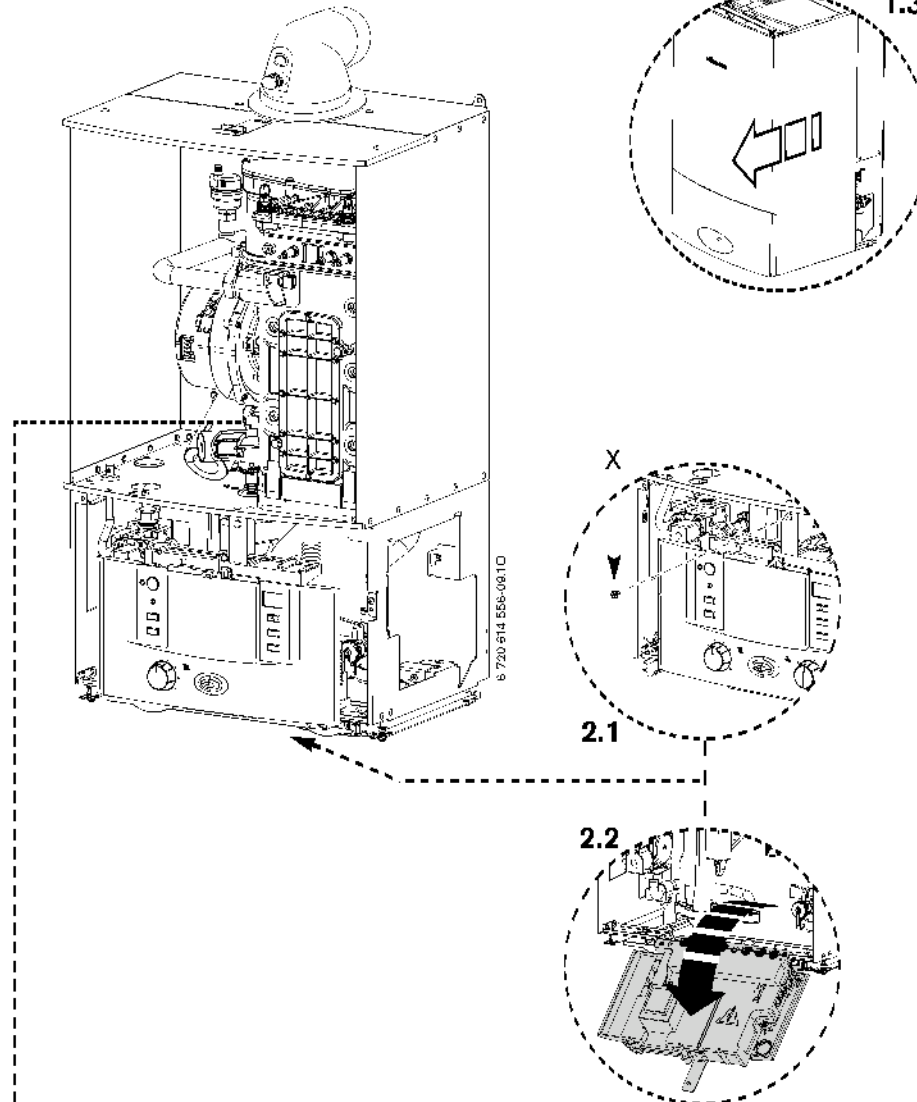

- 2.1 Remove screw (X) securing control.
- 2.2 Gently pull forward until it comes to rest in service position.

**Primary Heat Exchanger**

There is a special accessory kit available specifically designed for cleaning the heat exchanger. If required order 7 719 001 996.

3. ▶ Check fan pressure at the test point next to the fan using an electronic manometer
  - ▶ The boiler must be run at maximum output. Pressure will read negative and be greater than:

30CDi - 3.9 mbar  
40CDi - 4.4 mbar

▶ Pressures measured below these figures will indicate that the heat exchanger will require cleaning.

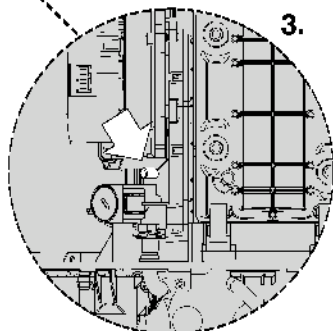

SERVICING & SPARES

**Setting Boiler to Maximum.**

- A - On/off button
- B - On/off and fault indicator (BLUE)
- C - Temperature control
- D - Burner indicator (GREEN)
- E - Reset button
- F - Service button
- H - Not used
- K - Display
- L - Boost button
- M - Not used

- 1 ▶ Press and HOLD boost button (L) for 10 seconds and set the heating temperature to maximum.
  - The boost button will illuminate continually.
  - The boiler will stay in this mode for 15 minutes unless the boost button is pressed again.
- 2 ▶ Pull the cover off and connect a manometer to the fan pressure test point.
  - ▶ After measurement replace test point cover.

Pressure will read negative and be greater than:

30CDi - 3.9 mbar

40CDi - 4.4 mbar

- Pressures measured below these figures will indicate that the heat exchanger will require cleaning.

- There is a special accessory kit available specifically designed for cleaning the heat exchanger. If required order 7 719 001 996.

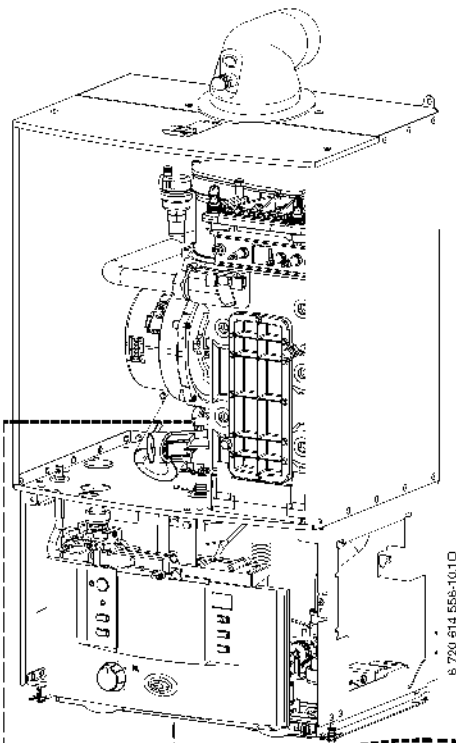

6 720 514 556-10.1D

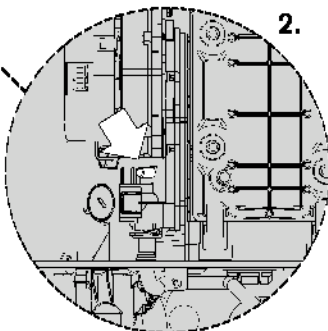
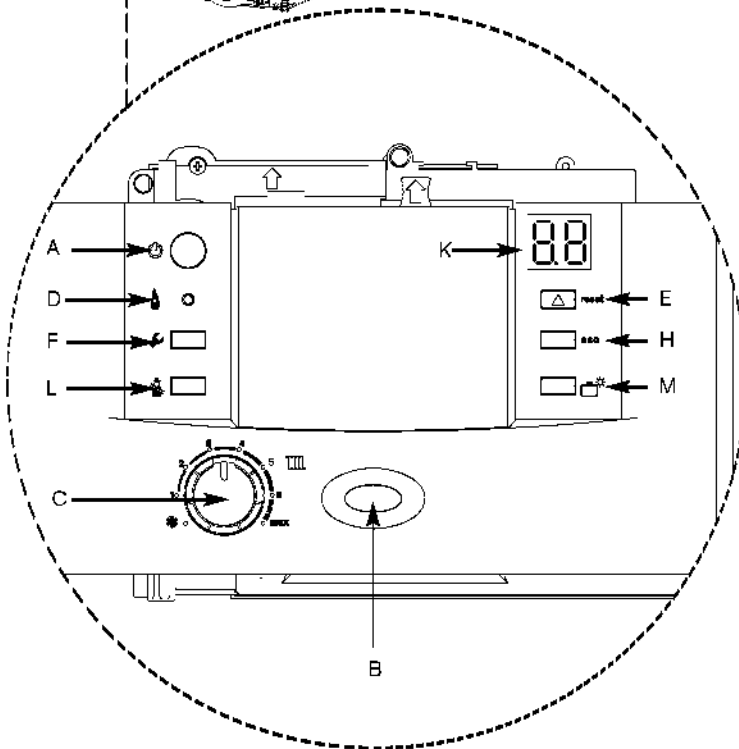

COMBUSTION TESTING MUST BE CARRIED OUT BY A COMPETENT PERSON. IT MUST **NOT** BE ATTEMPTED UNLESS THE PERSON CARRYING OUT THE COMBUSTION CHECK IS EQUIPPED WITH A COMBUSTION ANALYSER CONFORMING TO BS 7927 AND IS COMPETENT IN IT'S USE.

### To Clean the Heat Exchanger

- ▶ Remove outer case and base panel and isolate the appliance from power.
1. ▶ Remove cleaning access cover (B), seal (C) and metal plate (D) securing it, if present.
  - 2.1 ▶ Loosen any deposits in the heat exchanger from top to bottom using the cleaning blade.
  - 2.2 ▶ Clean the heat exchanger from top to bottom using the brush.
- ▶ Refit the clean out coverplates in reverse order using a new seal (C) and tighten screws to a torque of approximately 5 Nm.

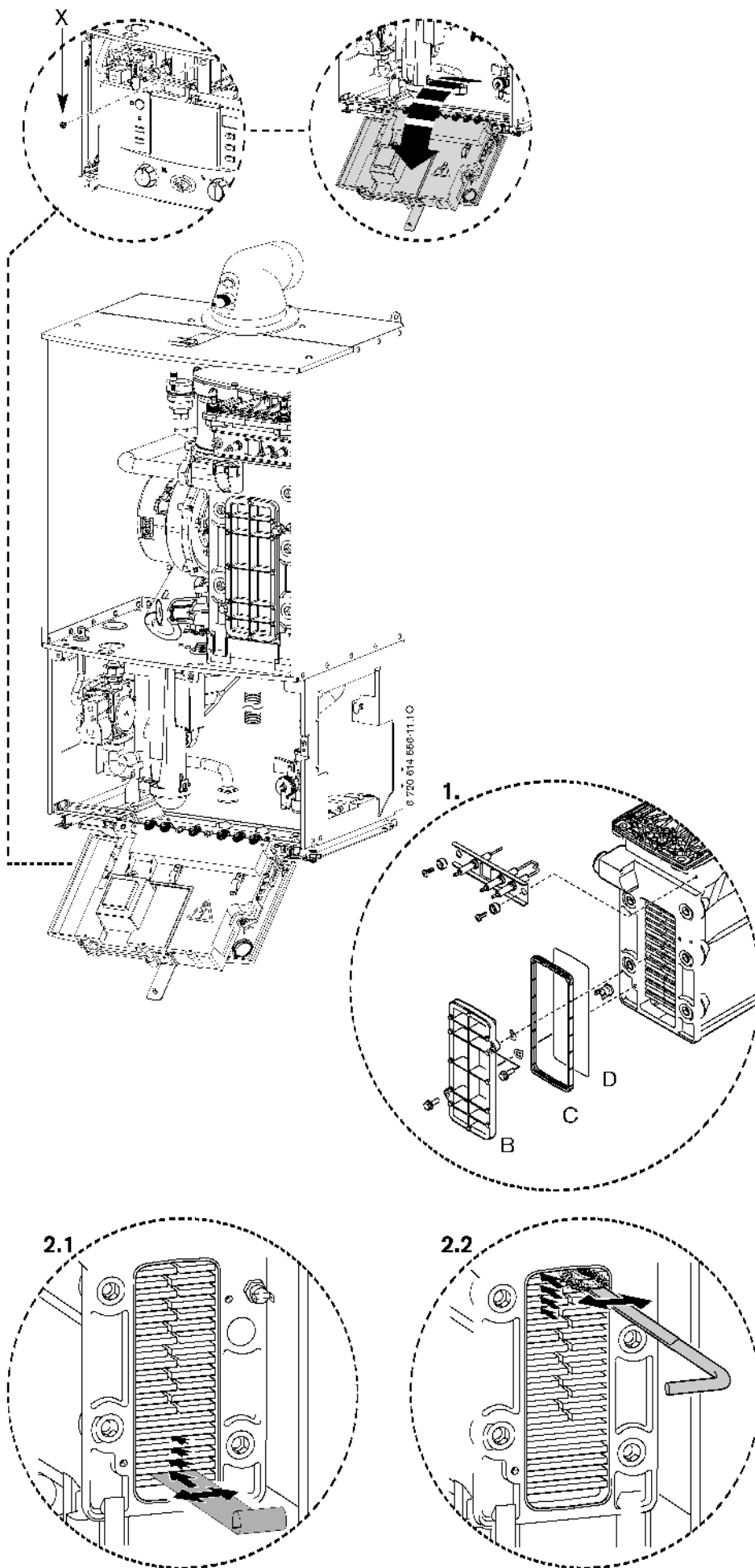

**To Clean the Burner**

1. ▶ Remove cover panel (A) by removing the screws (B).
  - ▶ Check that the boiler is completely isolated from the gas supply.
2. ▶ Remove the clips (C) and unscrew the two bolts (D).
  - ▶ Unscrew and remove the two hexagon screws (E) securing the fan.
  - ▶ Slacken fully the rear securing bolt (F).
  - ▶ Remove the burner cover plate (G).
3. ▶ Remove the burner (H) and clean components. **Do not use a wire brush.**

**To Check the Diaphragm in Burner Cover**

4. ▶ Carefully withdraw diaphragm (J) from fan intake tube and check for soiling and splits.
  - ▶ Carefully refit diaphragm (J) the correct way round into the fan intake tube.
 

*Note: The flaps of the diaphragm (J) must open upwards.*
  - ▶ Re-assemble burner in reverse order using a new seal (K).
  - ▶ Adjust gas/air ratio. Refer to section "Setting the gas/air ratio".

**To Clean the Condensate Trap**

- 5.1 ▶ Pull condensate pipe out of the adapter.
- 5.2 ▶ Remove trap from boiler.
  - ▶ Clean trap and check that the connection to the heat exchanger is clear.
  - ▶ Fill the condensate trap with approximately 1/4 litre of water and refit in reverse order.

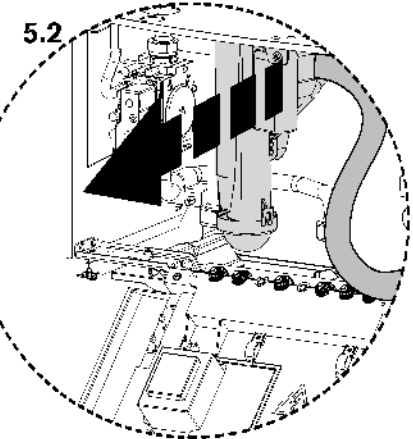
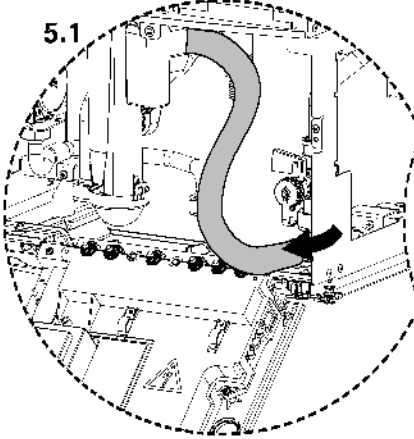
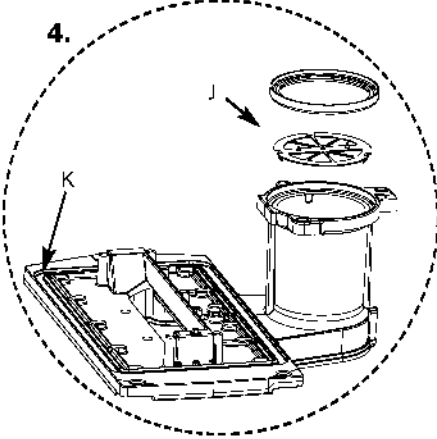
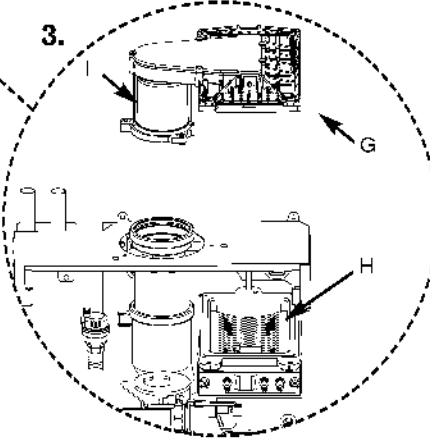
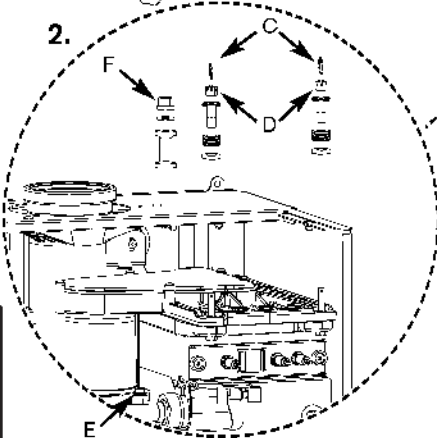
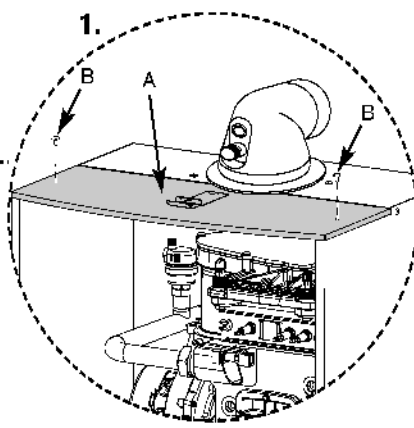
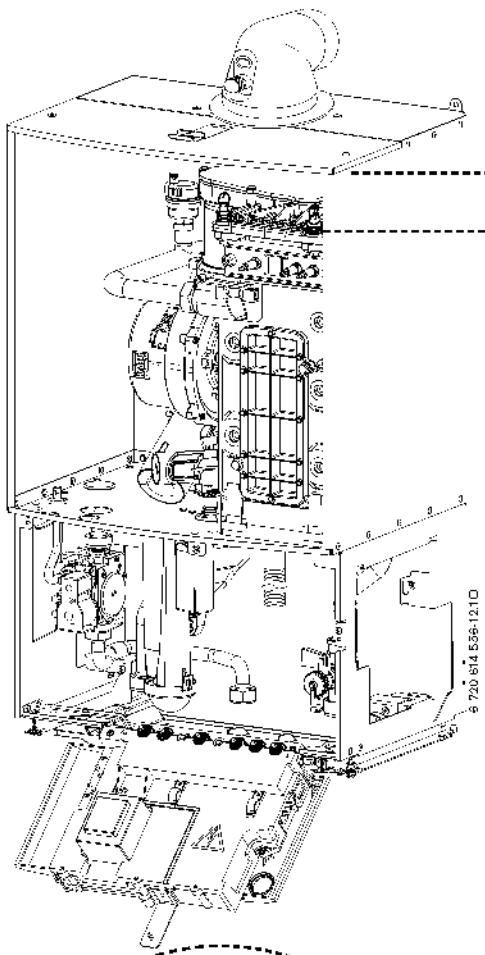

SERVICING & SPARES

**CAUTION: TURN OFF THE GAS SUPPLY AND ISOLATE THE MAINS SUPPLIES BEFORE STARTING ANY WORK AND OBSERVE ALL RELEVANT SAFETY PRECAUTIONS.**

## REPLACEMENT OF PARTS

**IMPORTANT: AFTER REPLACEMENT OF ANY COMPONENTS ALWAYS CHECK FOR GAS SOUNDNESS WHERE RELEVANT AND CARRY OUT FUNCTIONAL CHECKS AS DESCRIBED IN COMMISSIONING. ANY O-RING OR GASKET THAT APPEARS DAMAGED MUST BE REPLACED.**

### 1. Removing outer case

1. ▶ Remove bottom panel by pulling it forward and off.
- 1.1 ▶ Loosen but do not remove the 2 screws (A) securing boiler casing at the bottom of the appliance.
- 1.2 ▶ Pull upwards to release the clip (B) on top of the boiler.
- 1.3 ▶ Pull case forward and remove.

### 2. Moving boiler control to service position

- 2.1 ▶ Remove screw (X) securing control.
- 2.2 ▶ Gently pull forward.

### 3. Primary sensor

- ▶ Press retaining clip on plastic moulding and pull upwards until clear of pocket in heat exchanger.
- ▶ Separate sensor from connector, coat new sensor with heat conductive paste and replace.

### 4. Overheat thermostat

- ▶ Remove two electrical connectors from thermostat.
- ▶ Unscrew the sensor.

### 5. Flue limit thermostat

- ▶ Remove electrical connections.
- ▶ Unscrew thermostat from flue.

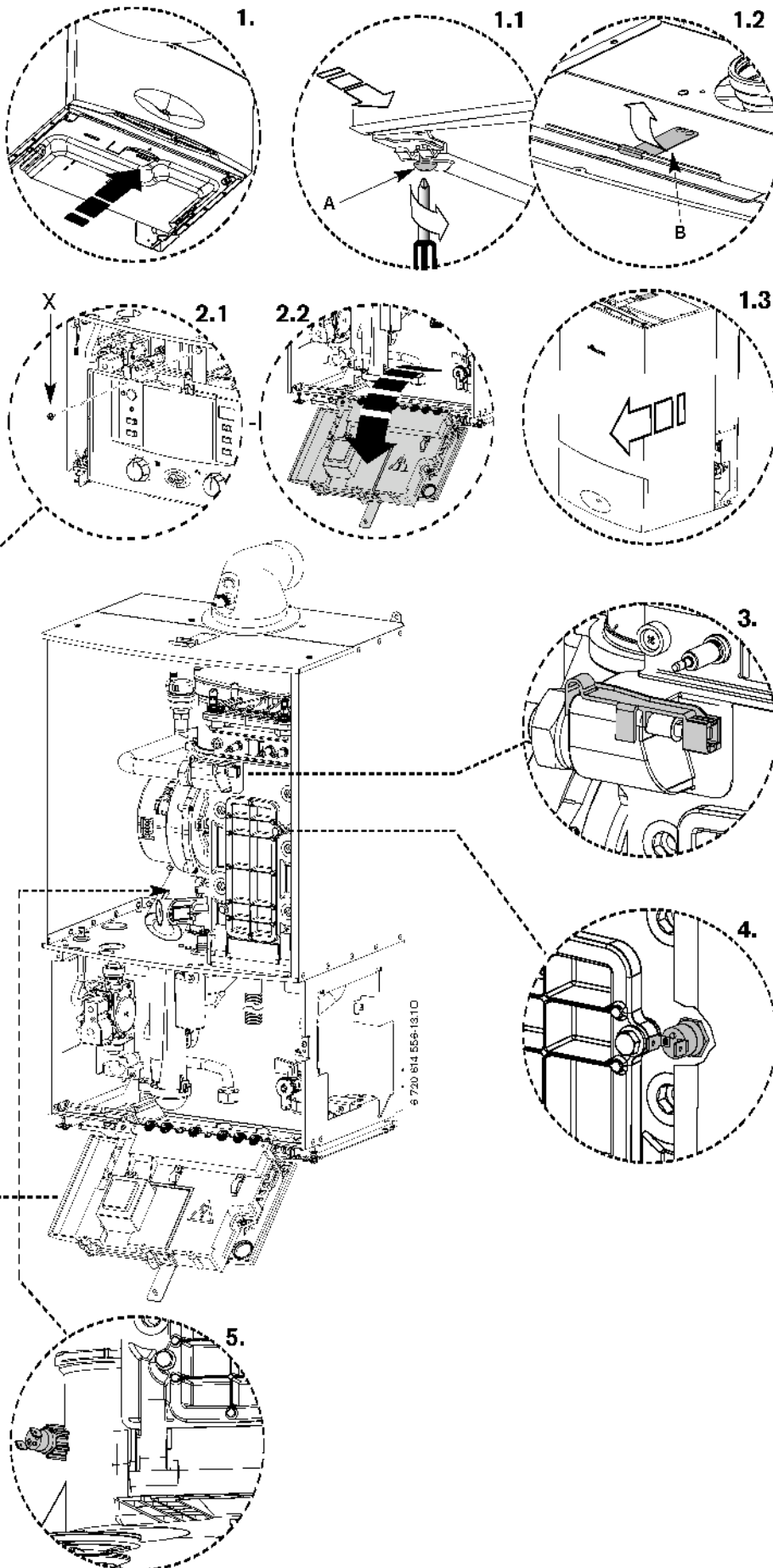

**6. Gas valve**

- ▶ Isolate gas supply at boiler gas cock.
- ▶ Pull out air inlet tube (A).

6.1 ▶ Undo top gas connection (B) to gas valve.

6.1 ▶ Undo bottom gas connection (C) to gas valve.

6.2 ▶ Undo two securing screws (D) on the underside of casing.

- ▶ Pull valve up and forward out of boiler.

- ▶ Disconnect electrical connections.

- ▶ Replace valve with new seals and check for gas soundness.

*Note: The valve will require setting, follow procedure "Setting the gas/air ratio" in the gas conversion section.*

**7. Siphon**

7.1 ▶ Pull condensate pipe out of the adapter.

7.2 ▶ Remove trap from boiler.

- ▶ Clean trap and check that the connection to the heat exchanger is clear.

- ▶ Fill the condensate trap with approximately 1/4 litre of water and refit in reverse order.

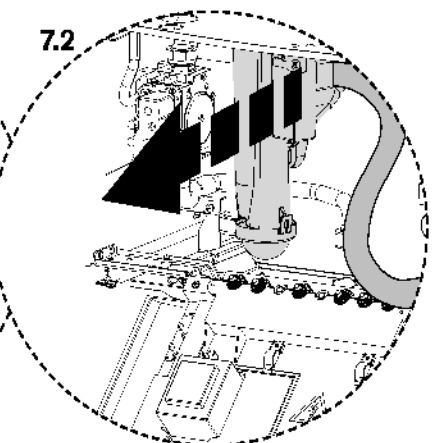
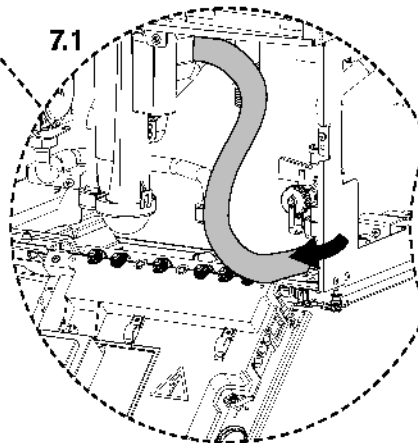
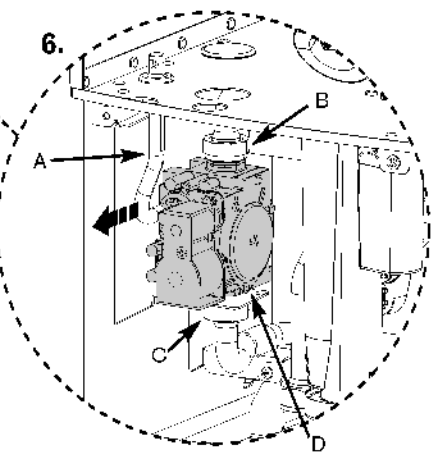
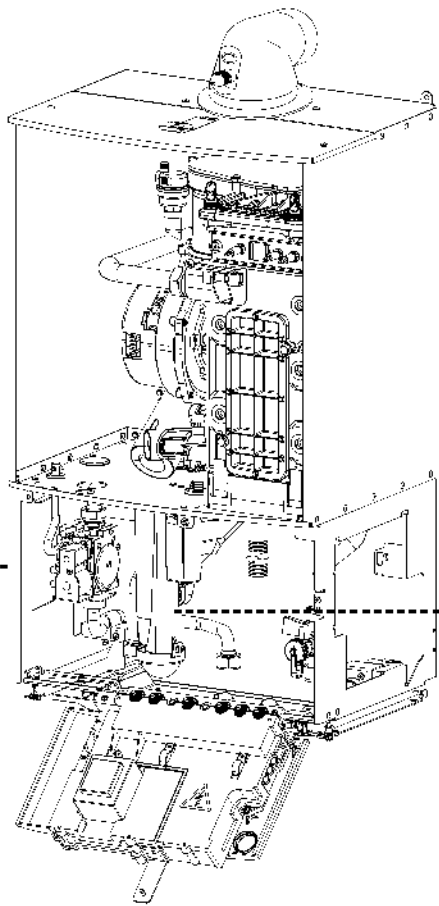

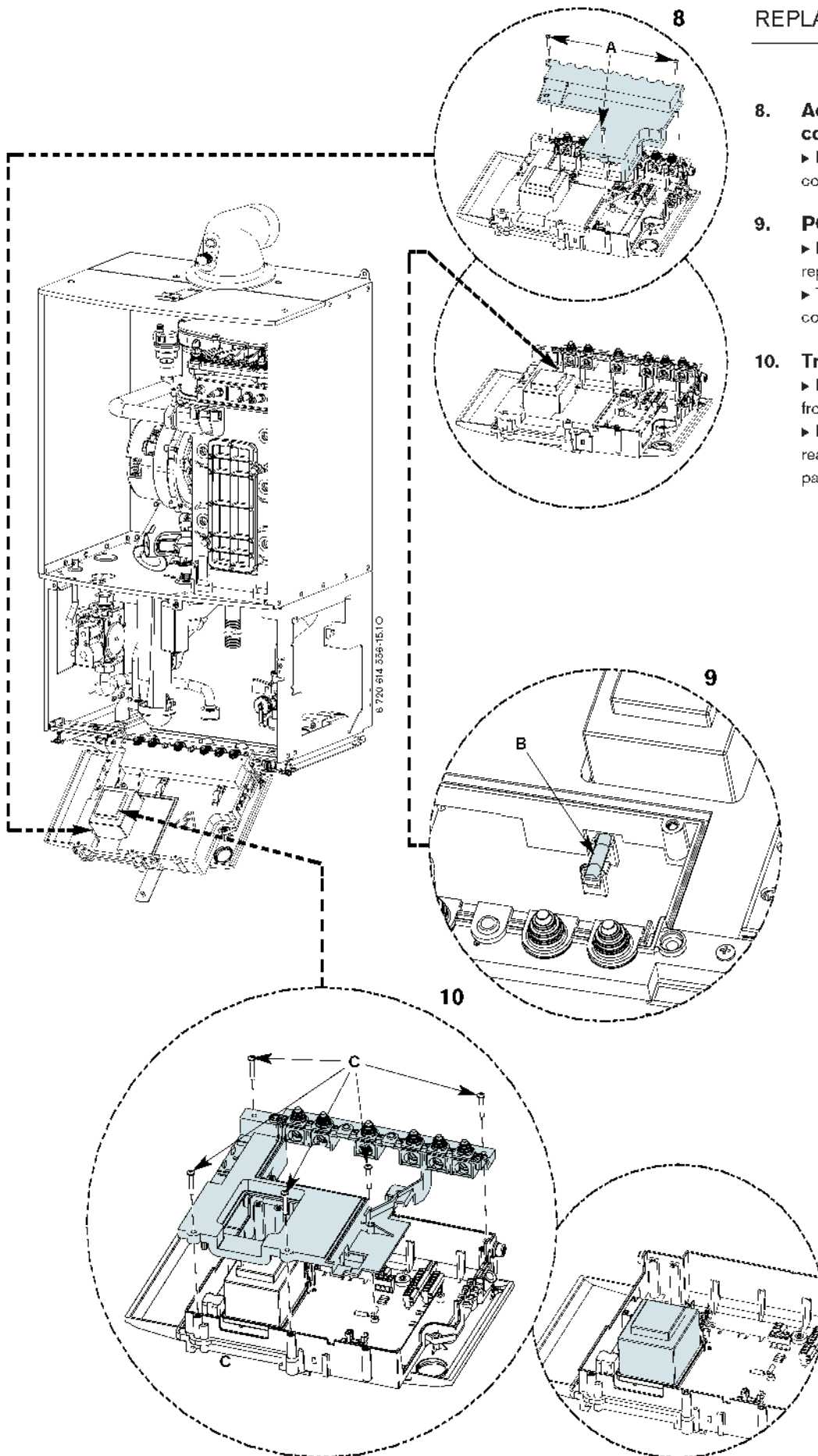

**8. Access to boiler control components**

▶ Remove 3 screws (A) and remove cover from control.

**9. PCB fuse**

▶ Remove fuse (B) from the PCB and replace.  
▶ There is a spare fuse clipped into the cover.

**10. Transformer / PCB**

▶ Disconnect all electrical connections from the control.  
▶ Remove 5 screws (C) retaining the rear panel of the control and remove panel.

SERVICING & SPARES



**13. Air/gas manifold**

- 13.1** ▶ Remove cover panel (A) by removing the screws (B).  
 ▶ Check that the boiler is completely isolated from the gas supply.
- 13.2** ▶ Remove the clips (C) and unscrew the two bolts (D).  
 ▶ Unscrew and remove the two hexagon screws (E) securing the fan.  
 ▶ Slacken fully the rear securing bolt (F).
- 13.3** ▶ Remove air/gas manifold (I)
- 13.4** ▶ Open air/gas manifold (I).  
 ▶ Carefully withdraw diaphragm (J) from fan intake tube and check for soiling and splits.

**14. Burner**

- ▶ Remove the burner (H).  
 ▶ Replace new burner in correct position.  
 ▶ Ensure that a new seal (K) is used.

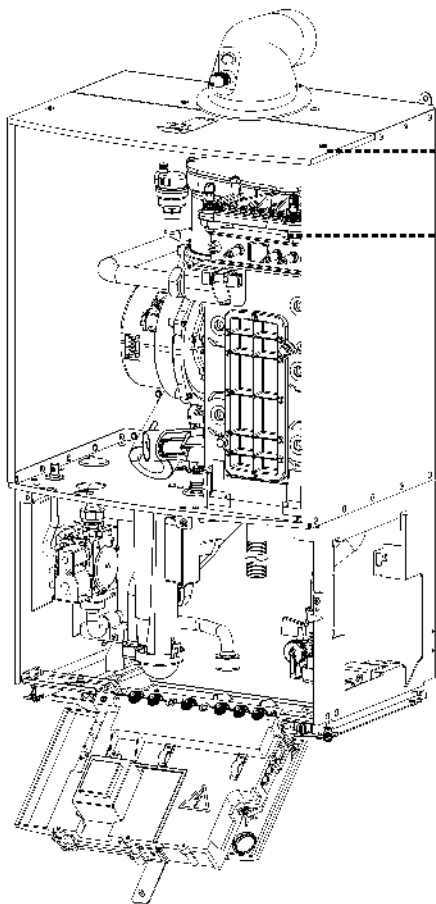

6 720 614 B60-171 O

**14.1**

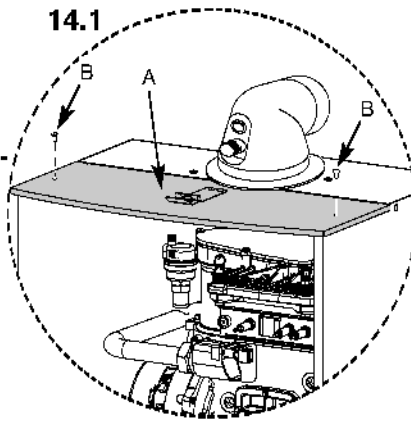

**13.2**

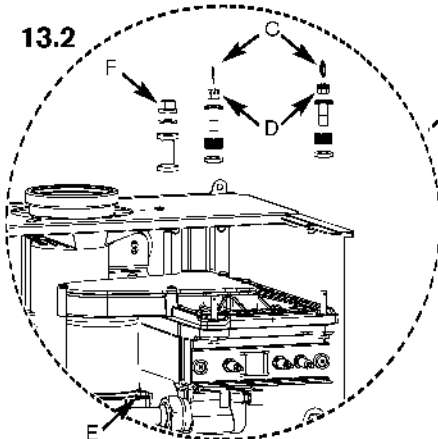

**13.3**

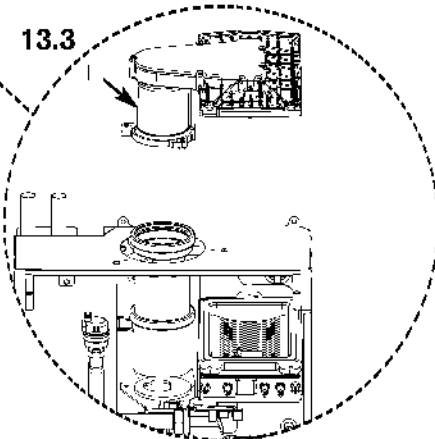

**13.4**

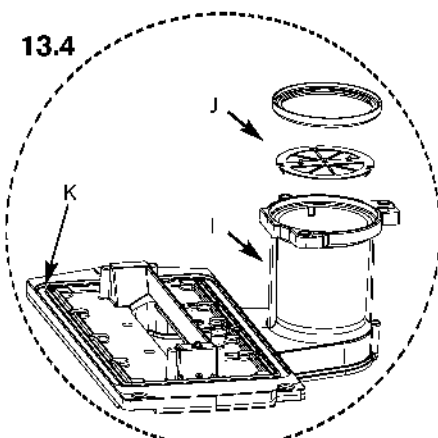

**14.**

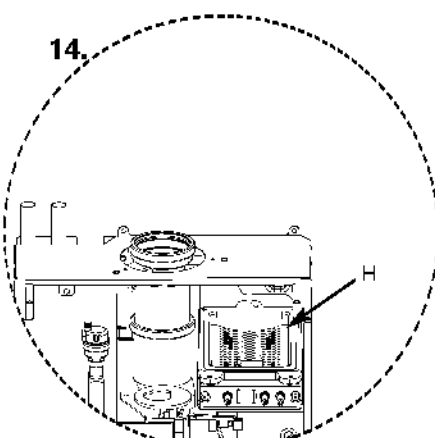

SERVICING & SPARES



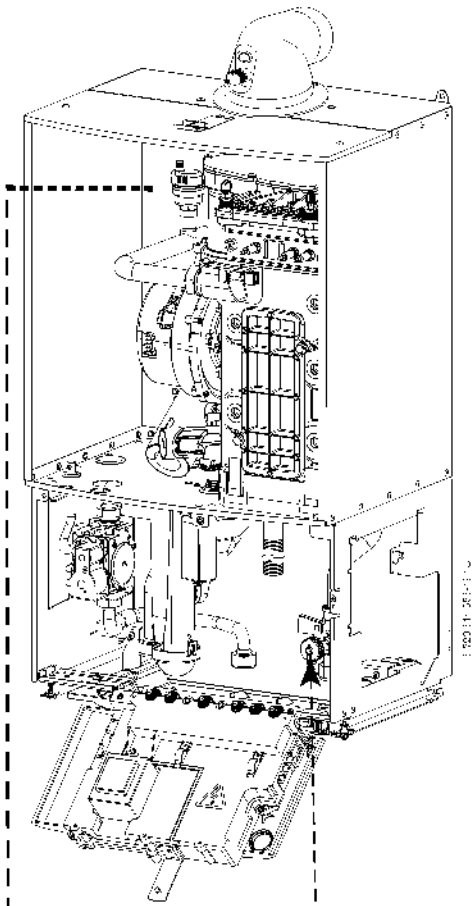

**16. Drain tap**

- ▶ Remove clip (A).
- ▶ Unscrew nut (B).
- ▶ Replace drain tap.

**17. Auto air vent**

- ▶ Ensure the appliance has been fully drained.

- 17.1 ▶ Unscrew air vent (C) and replace.

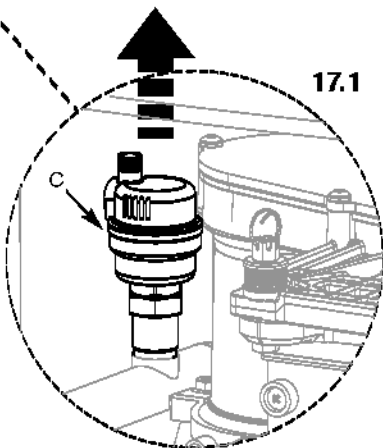
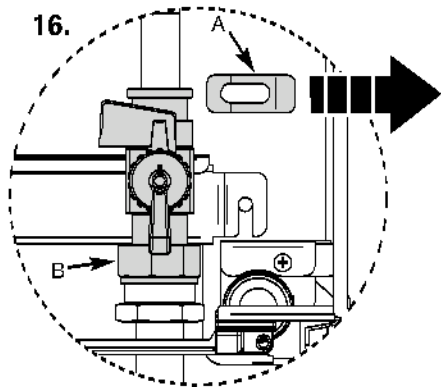

SERVICING  
& SPARES

THE SETTING OF THE GAS RATIO MUST BE CARRIED OUT BY A COMPETENT PERSON. SETTING OF THE GAS RATIO MUST **NOT** BE ATTEMPTED UNLESS THE PERSON CARRYING OUT THE CONVERSION IS EQUIPPED WITH A COMBUSTION ANALYSER CONFORMING TO BS 7927 AND IS COMPETENT IN ITS USE.

## SETTING THE GAS/AIR RATIO

### 5. Setting the CO<sub>2</sub>

- 5.1 ▶ Connect manometer to inlet pressure point on the gas valve.
- ▶ To adjust the CO<sub>2</sub> it will be necessary to first operate the boiler at maximum output.
  - ▶ Press and hold down the boost button (A) for 10 seconds until illuminated.
- 5.2 ▶ Turn heating control to maximum; the boiler will then go to maximum output.
- Note:** The control will resume normal operation after 15 minutes or if the boost button is pressed for over a second.
- 5.3 ▶ Using a flat blade screwdriver set the CO<sub>2</sub> via adjuster (B) using table below.
- Note: CO<sub>2</sub> should be measured 10 minutes after firing the appliance.*

Gas type	CO <sub>2</sub> setting maximum	CO <sub>2</sub> setting minimum
<b>Greenstar 30CDi</b>		
Natural gas	9.6 % ±0.2	9.0 % ±0.2
LPG	11.5 % ±0.2	10.5 % ±0.2
<b>Greenstar 40CDi</b>		
Natural gas	9.7 % ±0.2	9.1 % ±0.2
LPG	11.5 % ±0.2	10.5 % ±0.2

- ▶ Check CO is less than 200 ppm.
  - ▶ Measure the inlet pressure; it should be a minimum of 18 mbar for natural gas and 37 mbar for LPG.
- 5.4 ▶ Set the heating control to minimum. This will make the boiler go to minimum power.
- 5.5 ▶ Measure the CO<sub>2</sub>; it should now be at the figure for minimum output. If not adjust (C) on the gas valve until correct.
- ▶ Return to maximum and re-check the CO<sub>2</sub>. If correct press and hold down the boost button for 2 seconds; the button will cease to be illuminated and the blue power indicator will be permanently illuminated.
  - ▶ Remove manometer and re-seal inlet pressure point on gas valve.
  - ▶ Fit new plastic sealing cover on to outlet adjuster (B).
  - ▶ Fit white cover over valve adjuster (C) and secure with black security tag.
  - ▶ Remove red arrow from data plate and fit new one in correct position for gas type.
  - ▶ Re-assemble and refit boiler case.
  - ▶ Re-connect mains electrical supply and check boiler operation as stated in the commissioning section.
  - ▶ Fit new label from kit over existing label on the appliance bottom panel.

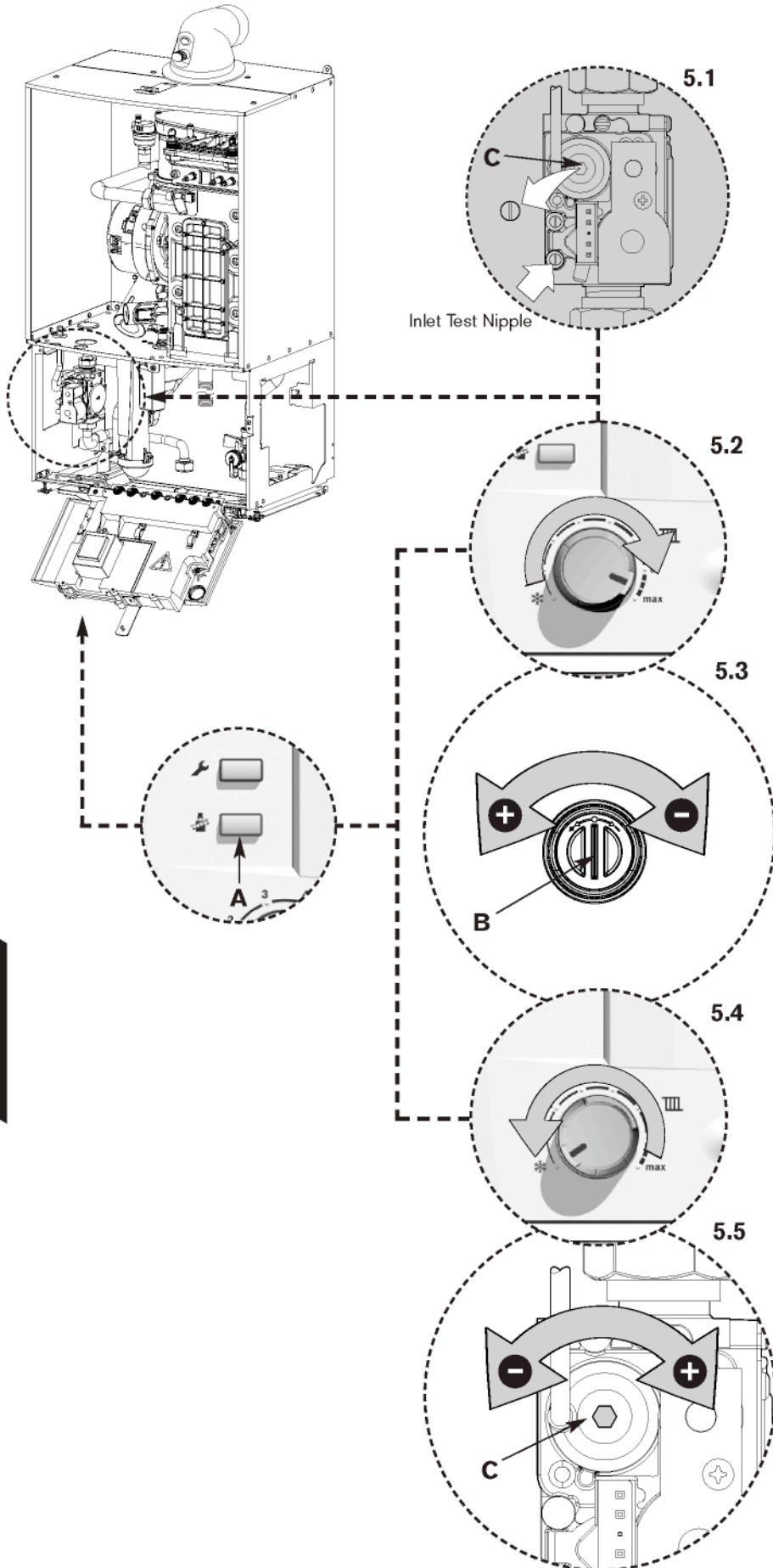

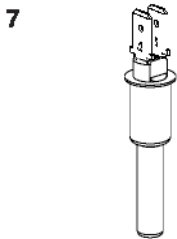
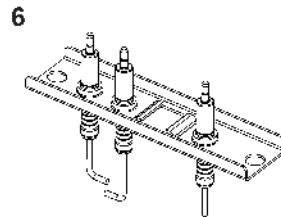
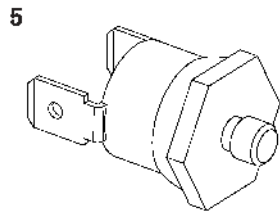
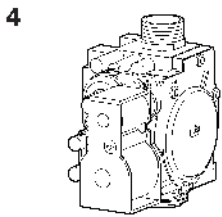
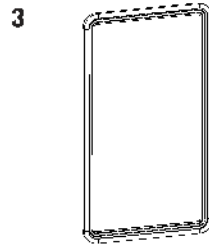
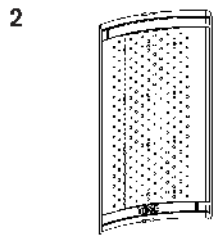
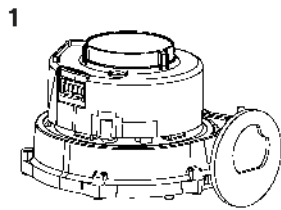

## SHORT PARTS LIST

- 1 Fan**  
WHS Part No. 8 717 204 453 0  
GC No. H26 536
- 2 Burner**  
WHS Part No. 8 718 006 658 0  
GC No. E27 200
- 3 Burner skin seal**  
WHS Part No. 8 711 004 168 0  
GC No. E27 201
- 4 Gas valve**  
WHS Part No. 8 718 221 347 0  
GC No. TO BE CONFIRMED
- 5 Temperature limit sensor**  
WHS Part No. 8 722 963 858 0  
GC No. H08 291
- 6 Electrodes**  
WHS Part No. 8 718 107 089 0  
GC No. H22 458
- 7 Control sensor - primary**  
WHS Part No. 8 714 500 087 0  
GC No. E74 536
- 8 Service booklet**  
Part No. 6 720 612 361 0  
GC No. TO BE CONFIRMED



**NOTE:** This fault finding information is for guidance only. Worcester Bosch cannot be held responsible for costs incurred by persons not deemed to be competent.

The electronic control system for this boiler incorporates a blue central indicator. This normally confirms the permanent mains supply but, by flashing during a fault, provides a guide to the cause as listed.

This fault finding system assumes that the appliance has been operating normally until the time of failure (i.e. not a first installation error).

**PRELIMINARY CHECKS:** Preliminary electrical system checks are the first electrical checks to be carried out during a fault-finding procedure. On completion of the Service/Fault-Finding task which has required the breaking and remaking of electrical connections, check (a) EARTH CONTINUITY, (b) SHORT CIRCUIT CHECK, (c) POLARITY and (d) RESISTANCE TO EARTH.

Display code	Description	Remedy
<b>b1</b>	Code plug not detected.	Insert code plug correctly, test and replace if necessary.
<b>C6</b>	Fan speed too low.	Check fan lead and connector, and fan; replace as necessary.
<b>E2</b>	Flow NTC sensor defective.	Check flow NTC sensor and connecting lead.
<b>E9</b>	Safety temp. limiter in flow has tripped.	Check system pressure, check safety temp. limiters, check pump operation, check fuse on pcb, bleed appliance.
<b>EA</b>	Flame not detected.	Is gas cock turned on? Check gas supply pressure, power supply, igniter electrode and lead, ionisation sensing electrode and lead, flue duct and CO <sub>2</sub> level.
<b>F0</b>	Internal error.	Check electrical connector contacts, programmer interface module ignition leads are not loose; replace pcb if necessary.
<b>F7</b>	Flame detected even though appliance switched off.	Check electrode assembly, dry pcb. Flue clear?
<b>FA</b>	Flame detected after gas shut off.	Check gas valve and wiring to gas valve. Clean condensation trap and check electrode assembly. Flue clear?
<b>Fd</b>	Reset button pressed by mistake.	Press reset button again.

More detailed fault finding procedures are described in the Service booklet for the Engineer number 6 720 612 361.

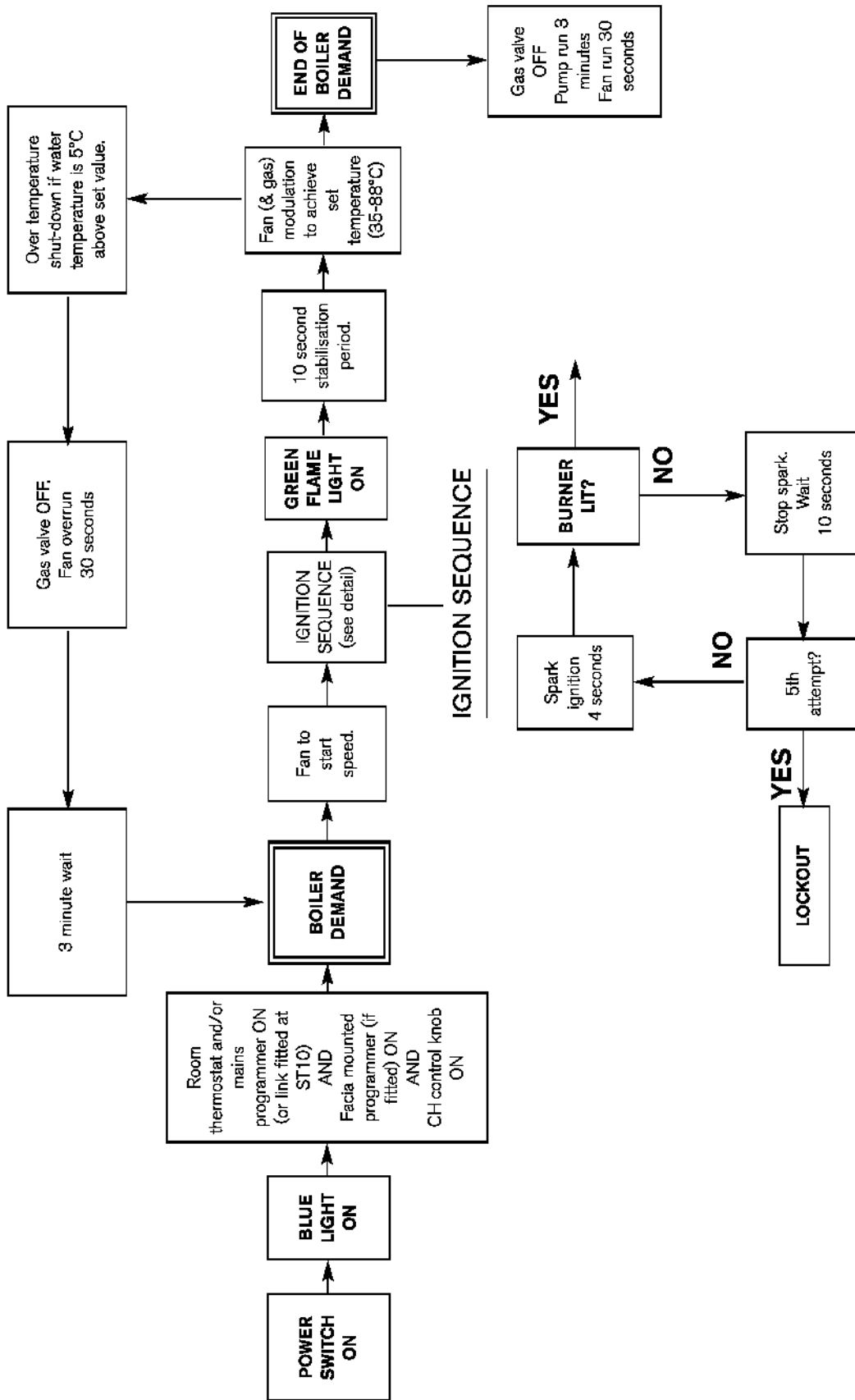

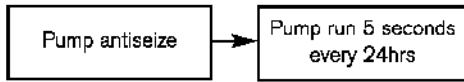





# **INSTRUCTION MANUAL INSTALLATION, COMMISSIONING & SERVICING**

## **EXCELLENCE COMES AS STANDARD**

Worcester, Bosch Group

Cotswold Way, Warndon, Worcester WR4 9SW.

Tel. 01905 754624 Fax. 01905 754619

Worcester, Bosch Group is a trading name of

BBT Thermotechnology UK Ltd.

[www.worcester-bosch.co.uk](http://www.worcester-bosch.co.uk)

6 720 614 556a (2007/07) OSW

