

Installation and Maintenance Instructions

Gas-fired condensing system appliance

Greenstar 4000

GR4700iW S



Table of contents

1	Explanation of symbols and safety instructions	4	5.5.1	Cable preparations	40
1.1	Explanation of symbols	4	5.5.2	Installer wiring connections	41
1.2	General safety instructions	4	5.5.3	External controls - Domestic installations	42
2	Regulations	7	6	Commissioning	43
3	Product Information	7	6.1	Pre-Commissioning checks	43
3.1	Scope of delivery	8	6.2	Water treatment	43
3.2	Declaration of Conformity	8	6.2.1	Filling the appliance and adding Inhibitor	43
3.3	Appliance type overview	8	6.3	Starting the appliance	44
3.4	Product identification	9	6.3.1	Control panel overview	44
3.5	Pipework positions and flue outlet	9	6.3.2	Turning on the appliance	44
3.6	Product overview	10	6.3.3	Operation	44
3.7	Standard accessories	11	6.4	Chimney sweep mode	44
3.7.1	Appliance accessories	11	6.4.1	Setting the appliance to maximum	45
3.7.2	Programmer/timer accessories	11	6.4.2	Setting the appliance to minimum	45
4	Pre-Installation	12	6.4.3	Exiting chimney sweep mode	45
4.1	System preparation	12	6.5	Checking gas inlet pressure	45
4.1.1	Artificially softened water	12	6.6	Checking the gas rate	46
4.1.2	Water systems and pipework	12	6.7	Checking for gas leaks during operation	46
4.1.3	System layouts examples	13	6.8	CO and combustion check	47
4.1.4	System fill	15	6.9	Checking flue integrity	48
4.2	Mains supply	15	6.10	Flue gas analysis	48
4.2.1	Electrical supply	15	6.11	Finishing commissioning	49
4.2.2	Gas supply	15	6.11.1	Appliance/product guarantee	49
4.3	Appliance location and clearances	16	7	Settings in the service menu	50
4.3.1	Appliance location	16	7.1	Operating the service menu	50
4.3.2	Rooms containing a bath or shower	17	7.2	Service menu	51
4.3.3	Appliance clearances	17	7.2.1	Overview of the service menu	51
4.4	Flue systems considerations	19	7.2.2	Benchmark and Info menu	53
4.4.1	Flue length	19	7.2.3	Settings menu	54
4.4.2	Flue options	19	7.2.4	Menu Function check	57
4.4.3	Plume management system	22	7.2.5	Reset menu	57
4.4.4	Flue terminal positions	22	7.2.6	Menu Demo mode	57
4.4.5	Plume re-direct and plume management terminal positions	26	7.3	Thermal disinfection	58
4.5	Condensate discharge	28	8	Inspection and maintenance	58
4.5.1	Appliance siphonic condensate trap	28	8.1	Inspection and maintenance considerations	58
4.5.2	Condensate pipework	28	8.2	Component access	59
4.5.3	Internal connections	28	8.3	Checking heat exchanger assembly	59
4.5.4	External connections	29	8.4	Check working gas inlet pressure	60
4.6	Pressure relief discharge	32	8.5	Flue gas analysis	60
4.6.1	Pressure relief pipework	32	8.6	Checking the flue integrity	60
4.6.2	Alternative PRV connections - Combined PRV/condensate	32	8.7	Cleaning the siphon and heat exchanger	60
4.7	Cleaning primary systems	33	8.7.1	Checking the electrodes and cleaning the heat exchanger	60
4.7.1	Flushing the system	33	8.7.2	Cleaning the condensate trap	63
5	Installation	34	8.8	Setting the air/gas ratio	64
5.1	Position the appliance	34	9	Replacement parts	65
5.1.1	Mounting frame fixing	35	9.1	Component access	65
5.2	Appliance connections	36	9.2	Draining the appliance	65
5.3	Hanging the appliance	37	9.3	Removing the heat exchanger assembly	66
5.4	Flue turret/adaptor installation	39	9.4	Checking/replacing the motor of the 3-way valve (appliances fitted with diverter valve accessory)	67
5.5	Electrical connection	40	9.5	Removing the pump	67
			9.6	Replacing the gas valve	68
			9.7	Replacing the expansion vessel	68

9.8	Replacing the PRV	68
9.9	Replacing the pressure sensor.....	68
9.10	Pressure gauge removal	69
9.11	Replacing the control unit	69
<hr/>		
10	Fault finding and diagnosis	70
10.1	Operating and fault displays	70
10.1.1	General information	70
10.1.2	Operating/Fault code table	71
10.1.3	Faults that are not displayed	78
<hr/>		
11	Environmental protection and disposal	81
<hr/>		
12	Data Protection Notice	81
<hr/>		
13	Technical Specifications/Logs	82
13.1	Technical data	82
13.2	Energy consumption	84
13.2.1	Product data on energy consumption	84
13.3	Component resistance characteristics	88
13.3.1	Sensor values - Flow temperature sensor	88
13.3.2	Sensor values - Cylinder temperature sensor	88
13.3.3	Sensor values - Flue overheat thermostat	88
13.3.4	Sensor values - Heat exchanger assembly temperate limiter	88
13.3.5	Sensor values - Outside temperature sensor	88
13.4	Code plug	88
13.5	Pump characteristic map of the heating pump	89
13.6	Internal wiring of the appliance	90
13.7	Gas Boiler System Commissioning Checklist and Warranty Validation Record	92
13.8	Inspection and maintenance checklist	93
13.9	Service and Interim Boiler Work Record	94

1 Explanation of symbols and safety instructions

1.1 Explanation of symbols

Warnings

In warnings, signal words at the beginning of a warning are used to indicate the type and seriousness of the ensuing risk if measures for minimizing danger are not taken.

The following signal words are defined and can be used in this document:

DANGER

DANGER indicates that severe or life-threatening personal injury will occur.

WARNING

WARNING indicates that severe to life-threatening personal injury may occur.

CAUTION

CAUTION indicates that minor to medium personal injury may occur.

NOTICE

NOTICE indicates that material damage may occur.

Important information



The info symbol indicates important information where there is no risk to people or property.

Additional symbols

Symbol	Meaning
▶	a step in an action sequence
→	a reference to a related part in the document
•	a list entry
–	a list entry (second level)

Table 1

1.2 General safety instructions

Please read these instructions carefully before starting installation.

- These instructions are applicable to the Worcester appliance model(s) stated on the front cover of this manual only and must not be used with any other make or model of appliance.
- These instructions apply in the UK and Ireland only and must be followed except for any statutory obligations.
- This appliance must be installed by a competent registered gas engineer, such as a **Gas Safe** registered engineer including a **British Gas** engineer. Failure to install correctly could lead to prosecution.

- If you are in any doubt, contact the Worcester, Bosch Group help line (0330 123 3366).
- Distance learning and training courses are available from Worcester.
- The BENCHMARK Commissioning Checklist can be found on page 92 of this Installation manual.

Notices for the target group

These installation instructions are intended for gas, plumbing, heating and electrical contractors. All instructions must be observed. Failure to comply with instructions may result in material damage and personal injury, including danger to life.

- ▶ Read the installation, service and commissioning instructions (heat source, heating controller, pumps, etc.) before installation.
- ▶ Observe the safety instructions and warnings.
- ▶ Follow national and regional regulations, technical regulations and guidelines.
- ▶ Record all work carried out.

Intended use

The appliance may only be used for heating water or domestic hot water in domestic properties.

- ▶ Observe the details on the data plate and the specifications (installation manual) to ensure correct use of this appliance.
- ▶ Worcester Bosch offer flue gas systems which are suitable for use with the appliance. It is the responsibility of the installer of the flue to ensure this flue gas system operates correctly and in a safe manner.

Misuse

Appliance must be used as per the intended use statement. Operation outside the parameters of the intended use is considered misuse and could cause harm to people and damage to property.

Accessories should be as per accessories list. Minimum operational parameters are included in this document.

Using the appliance outside of its intended use may also invalidate the manufacturer's guarantee.

⚠ If you smell gas

A gas leak could potentially cause an explosion. If you smell gas, observe the following rules:

- ▶ Prevent flames or sparks:
 - Do not smoke, use a lighter or strike matches.
 - Do not operate any electrical switches or unplug any equipment.
 - Do not use the telephone or ring doorbells.
- ▶ Turn off the gas at the meter or regulator.
- ▶ Open windows and doors.
- ▶ Warn your neighbours and leave the building.
- ▶ Prevent anyone from entering the building.
- ▶ Move well away from the building: call the National Gas Emergency Service on 0800 111 999.
- ▶ L.P.G. boilers: Call the supplier's number on the side of the gas tank.

⚠ Risk to life from carbon monoxide poisoning. There is a risk to life from escaping flue gases

- ▶ Do not modify the flue gas system.
- ▶ Ensure that flue pipes and gaskets are undamaged.

If flue pipes are damaged or leaking:

- ▶ Turn off and isolate the appliance.
- ▶ Open windows and doors.
- ▶ If necessary, leave the building and warn your neighbours.
- ▶ Prevent anyone from entering the building.
- ▶ Rectify any damage to the flue system immediately.

⚠ Danger to life from carbon monoxide

Carbon monoxide (CO) is a poisonous gas, which arises during the incomplete combustion of fossil fuels such as oil, gas or solid fuels.

Dangers arise, if carbon monoxide escapes from the heating system due to a fault or a leak and collects unnoticed in enclosed spaces.

You can neither see, taste nor smell carbon monoxide.

To avoid danger from carbon monoxide:

- ▶ Have the heating system inspected and serviced regularly by an approved contractor.
- ▶ Use a CO detector, which gives an alarm in good time if CO escapes.
- ▶ If you suspect a CO leak:
 - Warn your neighbours and leave the building immediately.
 - Call an approved contractor.
 - Have any defects rectified.

⚠ Installation and maintenance

Installation and maintenance must only be carried out by a competent registered gas engineer, such as a Gas Safe registered engineer or British Gas engineer.

- ▶ Carry out a gas tightness test after completing work on gas-carrying components.
- ▶ Only use original spares.

⚠ Electrical work

Electrical work must only be carried out by a qualified electrician:

- ▶ Before starting electrical work;
 - Ensure that the electricity supply is safely isolated and secured to prevent inadvertent re-connection. Information on safe isolation can be found in the Health and Safety Executive guidance HSG85.
 - Using test equipment approved to GS38 to confirm that the electricity supply is disconnected.
- ▶ Refer to the manufacturer's information when installing non Worcester components and systems to the Worcester appliance.

⚠ Handover to the user

When handing over, instruct the user how to operate the heating system and inform the user about its operating conditions.

- ▶ Explain how to operate the heating system and draw the user's attention to any safety relevant action.
- ▶ In particular:
 - Advise that alterations, servicing and repairs must only be carried out by a competent, registered gas engineer, such as a Gas Safe registered engineer or British Gas engineer.
 - Advise the user to have the appliance and system serviced annually to help ensure economy, safety and reliability.
- ▶ Point out the possible consequences (including personal injury, danger to life and material damage) of improper or inadequate inspection, cleaning and maintenance.
- ▶ Point out the dangers of carbon monoxide (CO) and recommend the use of CO detectors.
- ▶ Leave the installation instructions with the completed Benchmark Checklist (or a certificate confirming compliance with IS 813, Eire only) and the operating instructions with the user or at the gas meter.

⚠ Servicing

Advise the user to have the appliance and heating system thoroughly serviced annually by a competent, registered gas engineer, such as a Gas Safe registered engineer or British Gas engineer.

In Republic of Ireland servicing work must be carried out by a Registered Gas Installer (RGII).

Approved spares must be used to help maintain the efficiency, safety and reliability of the appliance.

⚠ Benchmark Service Record

The service engineer must complete the Benchmark Service Record at the back of this manual after each service.



Benchmark places responsibilities on both manufacturers and installers.

The purpose is to ensure that customers are provided with the correct equipment for their needs, that it is installed, commissioned and serviced in accordance with the manufacturer's instructions by competent persons and that it meets the requirements of the appropriate Building Regulations. The Benchmark Checklist can be used to demonstrate compliance with Building Regulations and should be provided to the customer for future reference.

Installers are required to carry out installation, commissioning and servicing work in accordance with the Benchmark Code of Practice which is available from the Heating and Hot water Industry Council who manage and promote the scheme.

Visit hhic.org.uk for more information.

⚠ Health and safety

The appliance contains no asbestos and no substances have been used in the construction process that contravene the COSHH Regulations (Control of Substances Hazardous to Health Regulations 1988).

⚠ Combustion and corrosive materials

Do not store or use any combustible materials (paper, thinners, paints etc.) inside or within the vicinity of the appliance.

Chemically aggressive substances can corrode the appliance and invalidate any warranty.

⚠ Fitting and modification

Fitting the appliance and any controls to the appliance may only be carried out by a competent engineer in accordance with the current Gas Safety (Installation and Use) Regulations.

Flue systems must not be modified in any way other than as described in the fitting instructions. Any misuse or unauthorised modifications to the appliance, flue or associated components and systems could invalidate the warranty. The manufacturer accepts no liability arising from any such actions, excluding statutory rights.

⚠ General manual handling guidelines

- ▶ Only remove packaging at the time of the final installation.
- ▶ Always use Health and Safety guidance for manual handling of an appliance.
 - Never lift or carry more than the safe guidance limit on your own.
 - Always use appropriate methods and equipment when lifting/carrying an appliance.
- ▶ Never lift or carry packages by the shipping straps.
- ▶ During handling and unpacking, wear safety gloves to prevent injuries to your hands.
- ▶ Dispose of packing materials appropriately.

⚠ Important handling instructions

Care should be taken when transporting, lifting and carrying the appliance.

- ▶ Use a means of transport suitable for handling appliances (e.g. sack truck with strap, stair climbing or step trolley).
- ▶ When handling appliances, secure them against a fall.
- ▶ Let only trained personnel undertake the handling.
- ▶ The correct method for handling heavy objects should be strictly observed, at all times.

2 Regulations

Installation regulations

Current Gas Safety (Installation and Use) Regulations:

All gas appliances must be installed by a competent, registered gas engineer, such as a Gas Safe registered engineer or British Gas engineer in accordance with the current regulations.

Failure to install appliances correctly could lead to prosecution.

The appliance must be installed in accordance with, and comply to, the current:

- ▶ Gas Safety Regulations
- ▶ IET Regulations
- ▶ Building Regulations (England)
- ▶ Building Regulations (Wales)
- ▶ Building Standards (Scotland) (Consolidation)
- ▶ S.I. No. 183 and 292 - Energy Performance of Buildings Regulations (Ireland; current version)
- ▶ Health and Safety Document 635 (The Electricity at Work Regulations 1989) and any other local requirements
- ▶ EU Regulations No. 811/2013 - Energy Labelling

Building Regulations Part L1A (Current version) - new dwellings

If the installation is in a new build property or it is a first time installation in an existing property, the heating systems must conform to current building regulations Part L1A.

The exception to this are single storey, open plan dwellings where the living area is more than 70% of the total usable floor area. Then this type of dwelling can be controlled as one zone.

An alternative would be individual electronically controlled TRVs.

For dwellings with a floor area over 150m², separate time and temperature control for each zone is required. It is best practice to fit Thermostatic Radiator Valves (TRV's) to all radiators except the area where the room thermostat is sited.

Building Regulations Part L1B (Current version) - existing dwellings

For appliance replacements on an existing system, it is not necessary to zone the upstairs and downstairs separately, compliance with the zone requirements can be achieved by a single room thermostat or programmable room thermostat.

While the system is drained down, it is best practice to fit Thermostatic Radiator Valves (TRV's) to all radiators except the area where the room thermostat is sited.

British Standards

Where no specific instruction is given, reference should be made to the relevant British Standard codes of Practice.

- BS7074:1
 - Code of practice for domestic and hot water supply
- BS6891
 - Installation of low pressure gas pipework up to 28mm (R1)
- BS5546
 - Installation of gas hot water supplies for domestic purposes
- EN12828
 - Central heating for domestic premises
- BS5440:1
 - Flues and ventilation for gas appliances of rated heating not exceeding 70kW (net): Flues
- BS5440:2
 - Flues and ventilation for gas appliances of rated heating not exceeding 70kW (net): Air Supply
- BS7593
 - Treatment of water in domestic hot water central heating systems

- BS6798
 - Installation of gas fired boilers of rated input up to 70kW (net)
- BS7671
 - IET Wiring Regulations

Irish Standards

The current relevant Irish standards should be followed, including:

- ECTI
 - National rules for electrical installations
- IS 813
 - Domestic Gas Installations

LPG Installations

An appliance using LPG must not be installed in a room or internal space below ground level unless one side of the building is open to the ground.

Timber framed buildings

Where the appliance is to be fitted to a timber framed building the guidelines laid down in BS5440: Part 1 and IGE "Gas Installations in Timber Frame Buildings" should be adhered to.

Water supply:

All seals joints and compounds (including flux and solder) and components used as part of the secondary domestic water system must meet the requirements of the WRC and hold approval by a notified body, e.g. WRAS. The installation must also comply with the requirements of Part G of the Building Regulations.

CH Water

Salt based artificially softened water must not be used to fill the central heating system.

3 Product Information

Appliance features

- Aluminium-silicon heat exchanger.
- Low NOx emissions.
- Direct burner ignition.
- Built-in appliance frost protection.
- Built-in fault finding diagnostics.
- Zero pressure governor gas valve with fully modulating fan.
- Display for appliance status and access to diagnostics, system and commissioning parameters.
- Four hour memory retention after power interruption.
- Low energy modulating pump.
- Condensing in CH and DHW modes.
- Eco mode, to increase hot water cylinder hysteresis. ¹⁾
- Galvanised steel wall mounting frame provides vertical pipe route behind the appliance.
- Compatible with Worcester standard and intelligent controls.
 - See accessories list for available controls. ¹⁾
- Condensfit II flue systems 60/100 and 80/125 mm allows plume re-direction.
- Condensfit II flue systems 60/100 allows the ability to attach plume management kit.
- Front accessible components for maintenance.
- Large volume siphon mitigating the risk of condensate freezing.
- Digital Pressure sensor

1) Function available when optional integral diverter valve kit is fitted.

3.1 Scope of delivery

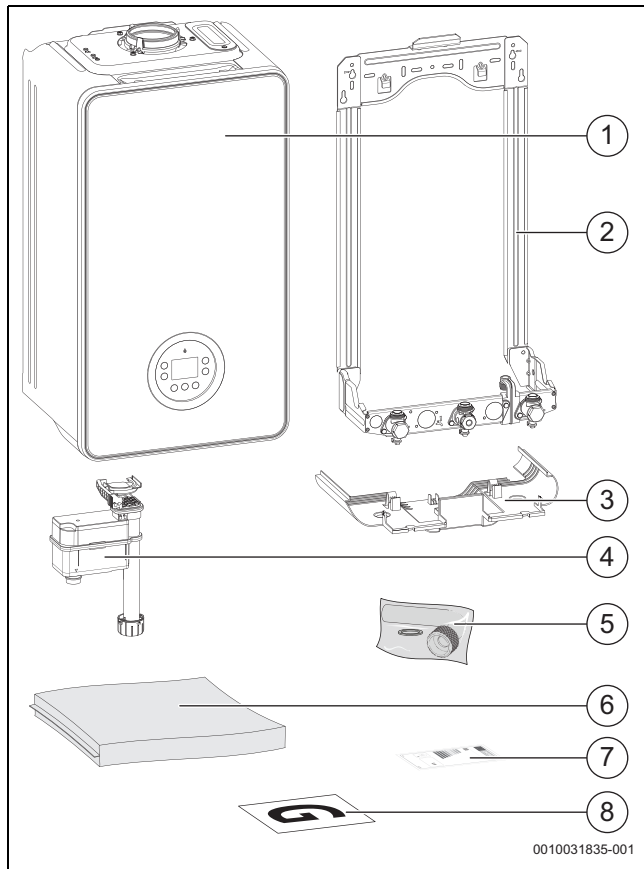

Fig. 1 Scope of delivery

- [1] Wall mounted gas-fired condensing system appliance.
- [2] Wall mounting frame.
- [3] Bottom panel.
- [4] Siphon.
- [5] PRV installer connection elbow.
- [6] Hardware literature pack:
 - Installation and Maintenance Instructions,
 - User Instructions,
 - Wall mounting template,
 - PRV installer connection elbow.
 - Condensate siphon connection elbow.
- [7] ErP label.
- [8] Guarantee card.

3.2 Declaration of Conformity

The design and operation of this product comply with European Directives and the supplementary national requirements. Conformity has been demonstrated by the CE marking.

You can ask for a copy of the declaration of conformity for this product. For this see the contact address on the back cover of these instructions.

3.3 Appliance type overview

These appliances are for use with:

- Natural Gas or L.P.G. (Cat.II 2H3P type C13, C33 & C53)

This document refers to the following appliance types:

Appliance type	Part number	Gas Council number
GR4700iW 24 S NG	7 733 600 385	41-800-15
GR4700iW 21 S NG	7 733 600 383	41-800-13
GR4700iW 18 S NG	7 733 600 381	41-800-11
GR4700iW 15 S NG	7 733 600 379	41-800-09
GR4700iW 12 S NG	7 733 600 377	41-800-07
GR4700iW 24 S LPG	7 733 600 386	41-800-16
GR4700iW 21 S LPG	7 733 600 384	41-800-14
GR4700iW 18 S LPG	7 733 600 382	41-800-12
GR4700iW 15 S LPG	7 733 600 380	41-800-10
GR4700iW 12 S LPG	7 733 600 378	41-800-08

Table 2 Type overview

The name of the appliance consists of the following parts:

- GR4700iW: Type name
- 12, 15, 18, 21 or 24: Heat output in kW
- S: System appliance
- NG: Gas type (Natural Gas)
- LPG: Gas type (Liquid Petroleum Gas)

3.4 Product identification

Data plate

The data plate includes the product performance information, approval data and serial number. The data plate location can be found in the product overview.

Additional type plate

The product name and the most important product data are shown on the additional data plate. The additional type plate can be found on the outside of the product in an easily accessible location.

The additional type plate can be found on the underside of the appliance.

3.5 Pipework positions and flue outlet

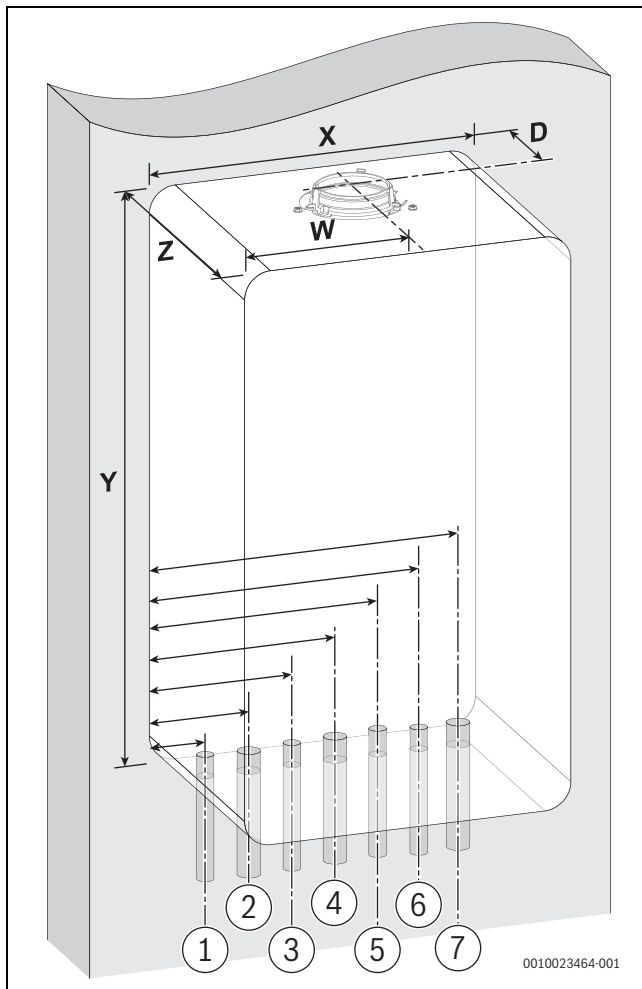

Fig. 2 Pipe and flue outlet dimensions

	Description	Dimensions (mm)
X	Appliance width	400
Y	Appliance height	724 ¹⁾
Z	Appliance depth	310
W	Flue centre from appliance left side	200
D	Flue centre from rear of appliance	135

1) 724mm to middle of top panel.
710mm side panel height.
Bottom panel is removable and not part of minimum clearance height requirements.

Table 3 Appliance and flue outlet dimensions

#	Function	From left case edge	Diameter of pipe
1	Condensate Outlet	38mm	22mm • Rubber push fit connection
2	Flow • CH/Cylinder ¹⁾	70mm	22mm • Compression fitting
3	Cylinder Flow ²⁾	135mm	15mm • Compression fitting
4	Gas	200mm	22mm • Compression fitting
5	Cylinder Return ²⁾	265mm	15mm • Compression fitting
6	PRV Discharge	296mm	15mm • Fittings not supplied
7	Return • CH/Cylinder ¹⁾	330mm	22mm • Compression fitting

1) Cylinder connections shared when optional integral diverter valve kit is not fitted.

2) Only available if optional integral diverter valve kit is fitted.

Table 4 Pipe dimensions

3.6 Product overview

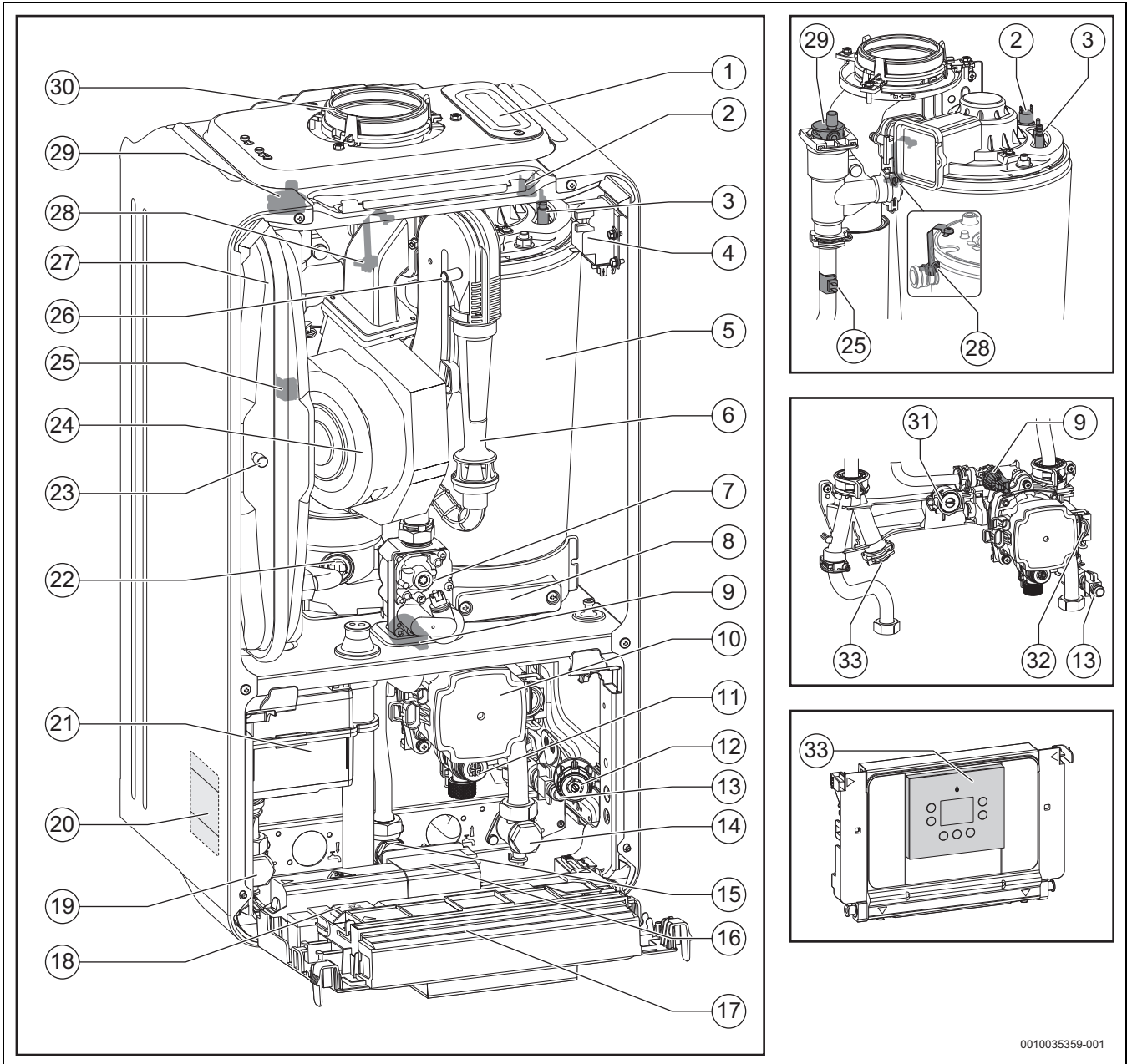

0010035359-001

Fig. 3 Product overview

Legend to figure 3:

- [1] Inspection / Heat exchanger cleaning access
- [2] Heat exchanger assembly limit temperature sensor
- [3] Electrode set
- [4] Ignition transformer
- [5] Heat exchanger assembly
- [6] Gas-air mixing chamber/venturi
- [7] Gas valve ¹⁾
- [8] Cover for inspection aperture
- [9] Pressure sensor
- [10] Pump
- [11] Pressure-relief valve (heating circuit)
- [12] Pressure gauge
- [13] Drain valve
- [14] CH return connection
- [15] Gas connection
- [16] Key control (accessory) housing ²⁾
- [17] Control unit
- [18] Fuse (replacement)
- [19] CH flow connection
- [20] Data plate
- [21] Condensate siphon
- [22] Flue gas temperature limiter
- [23] Schraeder valve
- [24] Fan
- [25] Flow temperature sensor (supply sensor) at flow pipe
- [26] Fan pressure test point
- [27] Expansion vessel
- [28] Zero flow sensor
- [29] Automatic air vent
- [30] Flue system connection
- [31] Position for cylinder flow pipe ³⁾
- [32] Position for diverter valve ^{1) 3)}
- [33] Position for cylinder return pipe ³⁾
- [34] Control panel

-
- 1) These components are sourced from multiple suppliers and therefore contain small design differences. Please refer to the relevant maintenance chapter for more detailed information. Spare parts are fully interchangeable.
 - 2) Key accessory only available if optional integral diverter valve kit is fitted.
 - 3) Optional integral diverter valve kit.

3.7 Standard accessories
3.7.1 Appliance accessories

Part number	Description
7 733 601 245	4000 SimpleSwitch flue adaptor 60/100
7 733 601 250	4000/Compact Pre-piping kit
7 733 600 266	Greenstar System filter (22mm mini)
7 733 600 236	Greenstar System filter (22mm)
7 733 600 237	Greenstar System filter (28mm)
7 733 600 476	Greenstar System filter brass (22mm)
7 733 601 316	Earth bonding strip
7 733 601 314	4000/Compact Remote PRV Kit
7 733 601 251	Greenstar 4000 System Diverter Valve Kit ¹⁾
7 733 600 091	Heat exchanger cleaning kit

1) Optional Worcester controls are available if the integral diverter valve kit is used.

Table 5 Appliance accessories

3.7.2 Programmer/timer accessories

The programmers/timers and smart controls listed can be used with the appliances stated on the front of this manual **in conjunction** with the optional integral diverter valve kit.

Part number	Description
7 738 110 054	Sense I
7 738 111 064	Sense II (including weather sensor)
7 738 112 323	Comfort+ I RF
7 738 112 324	Comfort+ II RF
7 738 112 338	Comfort+ stat RF ¹⁾
7 738 112 321	Comfort+ ²⁾

1) Must be used with an additional timer.

2) Must be used with additional temperature controls.

Table 6 Control accessories

Bosch EasyControl smart control system

Part number	Description
7 736 701 341	EasyControl (white)
7 736 701 392	EasyControl (black)
7 738 112 351	EasyControl RF key
7 736 701 555	EasyControl TRV set (white)
7 736 701 556	EasyControl TRV set (black)
8 750 000 270	EasyControl smart TRV (individual)

Table 7 EasyControl accessories

Basic weather compensation sensor

Outdoor weather sensor (to activate on-board simple Weather Compensation).

Part number	Description
7 716 192 764	Outdoor weather sensor

Table 8 Control accessories



The outdoor weather sensor is supplied with the Sense II. It is optional with the Comfort+ II RF. Weather compensation is available with the EasyControl without the need for a physical outdoor sensor, however, it can improve control accuracy for installations in isolated micro-climates or highly sheltered locations such as valleys.

4 Pre-Installation

NOTICE

Risk of damage to system or appliance!

Before installation

- ▶ All the following Pre-Installation sections must be read and requirements met before starting appliance or flue installations.



Before continuing with the preparation and installation
If using the optional integral diverter valve kit ensure that:

- ▶ All of the required equipment for the installation is available (→ Diverter valve kit instructions for details).
- ▶ The integral diverter valve kit installation instructions are read in conjunction with these instructions.

4.1 System preparation

4.1.1 Artificially softened water

The heating system must not be filled with water which has been treated using an ion exchange (salt based) water softener. Where these water softeners are installed, a permanent untreated water supply should be provided to maintain pressure in the heating system.

A bypass must be provided at the water softener to comply with BS:14743. Where a permanent untreated supply cannot be provided, the system must be initially filled using the bypass provided at the water softener. Occasional topping up of the system with artificially softened water is acceptable. Inhibitor must be added to the system. The pH levels must be between 6.5 and 8.0 at the time of commissioning. When a permanent untreated supply is not provided to the heating system filling point, the pH levels must be checked annually and recorded in the service record.

NOTICE

Risk of damage to appliance!

- ▶ The heating system must not be filled with water which has been treated using an ion exchange water softener.
- ▶ If the system is partially drained for maintenance or repair work, the system must be refilled by utilising the bypass valve at the water softener. The pH and inhibitor levels should be checked.

4.1.2 Water systems and pipework

Primary system plastic pipework:

- Any plastic pipework must have a polymeric barrier, complying with BS 7921 and installed to BS 5955 with 600mm (minimum) length of copper connected to the appliance.
- Plastic pipework used for under-floor heating must be correctly controlled with a thermostatic blending valve limiting the temperature of the circuits to approximately 50°C with 1000mm (minimum) length of copper or steel pipe connected to the appliance.

Primary system/connections/valves:

- Do not use galvanised pipes or radiators.
- All system connections, taps and mixing valves must be capable of sustaining a pressure of 3 bar.
- Radiator valves should conform to BS 2767:10.
- All other valves should conform to BS 1010.
- It is best practice to fit Thermostatic Radiator Valves (TRV's) to all radiators, except the area where the room thermostat is sited which must be fitted with lockshield valves that are left open.

- If the circulating pump speed is fixed and system circulation can be significantly adjusted or stopped by TRV's or zone valves, a system bypass should be installed to give at least a 3 metre circuit when activated. However; any appliance fitted with a modulating pump may not require a system bypass.
- Drain cocks are required at all the lowest points on the system.
- Air vents are required at all high points on the system.

Primary system considerations - Combi & System appliances Sealed system

- The CH sealed system must be filled using a WRAS approved filling loop or comply with examples in section 4.1.4 "System fill".
- Where the system volume is more than 100 litres or exceeds 2.5 bar at maximum heating temperature an additional expansion vessel [2] must be fitted as close as possible to the appliance in the central heating return.
- Pressurise the extra expansion vessel [2] to the same value as the built-in expansion vessel [1] (default pre-charge pressure is 0.75 bar).

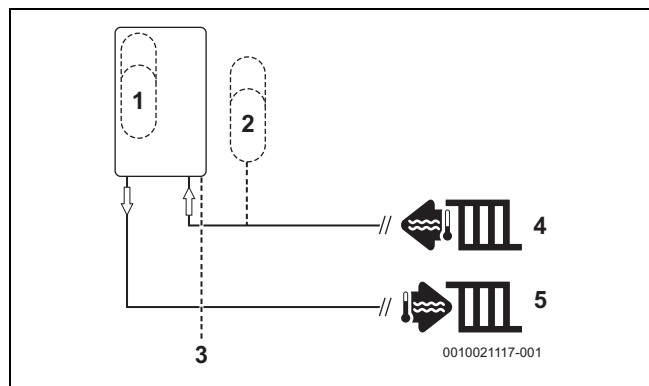

Fig. 4 Additional expansion vessel

- [1] Appliance expansion vessel
- [2] Additional expansion vessel
- [3] Pressure relief discharge
- [4] Heating return
- [5] Heating flow

Checking the size of the expansion vessel

To determine whether an additional expansion vessel is required: Follow the steps below:

- ▶ Calculate the total system volume (litres).
 - Plot a line vertically on the chart (→ Fig. 5).
- ▶ Determine the central heating maximum operating flow temperature.
 - Plot a line horizontally on the chart (→ Fig. 5).
- ▶ Determine the pre-charge in the expansion vessel based on static head, 1 metre = 0.1 bar.
 - Static head should be measured between the expansion vessel and the highest point on the system (top of the highest radiator).
- ▶ Select a curve from the key below (1-5).
- ▶ System pressure should be set at 0.1 - 0.25 bar higher than the vessel pre-charge.
 - It must be at least to the minimum on appliances with an analogue gauge.
 - Minimum pressure settings may need to be adjusted to suit on, appliances with a digital gauge, in the applicable menu function.
 - Intelligent filling settings may need to be adjusted to suit on, appliances with the automatic filling accessory, in the applicable menu function.

If the dissected lines are in area A then no additional expansion is required.

If the dissected line is in are B then an additional expansion vessel must be installed (→ Fig. 4).

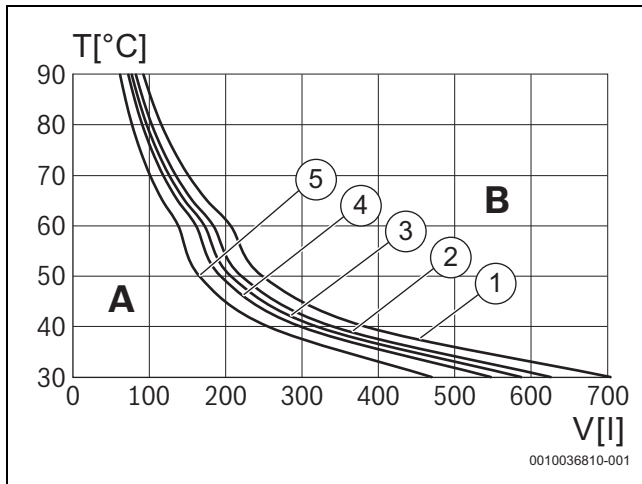

Fig. 5 Curves for the expansion vessel

- 1 Pre-charge pressure 0.5 bar (minimum)
- 2 Pre-charge pressure 0.75 bar
- 3 Pre-charge pressure 1.0 bar
- 4 Pre-charge pressure 1.2 bar
- 5 Pre-charge pressure 1.3 bar
- A Operational capacity of the expansion vessel (left of the relevant curve)
- B Additional expansion vessel required (right of the relevant curve)
- T Maximum operating temperature [°C]
- V Total System Volume [l]



The default pre-charge pressure for the expansion vessel is 0.75 bar

4.1.3 System layouts examples

Sealed primary system - Cylinder and central heating zone:

Typical S-Plan example

- The cylinder return must be the last connection on the common return pipe to prevent reverse circulation.

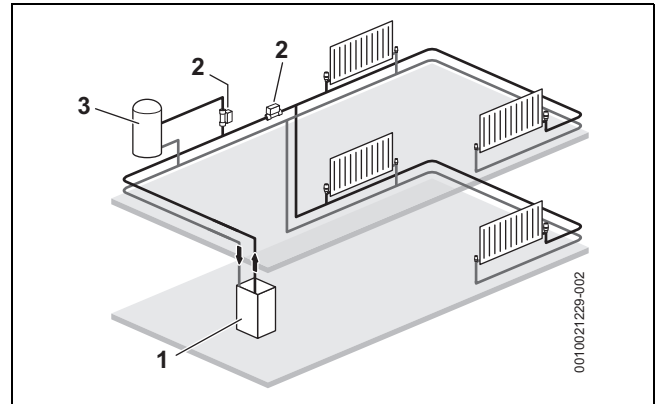

Fig. 6 Cylinder and heating zone

- [1] Appliance
- [2] Zone valves
- [3] Hot water cylinder

Sealed primary system - Cylinder and 2 x central heating zones:

Typical S-Plan Plus example

- The cylinder return must be the last connection on the common return pipe to prevent reverse circulation.

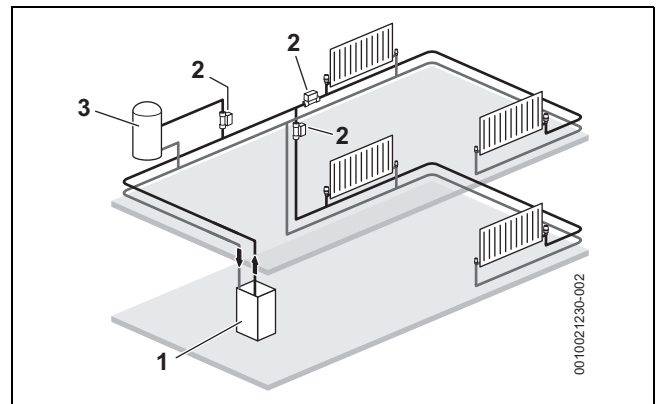

Fig. 7 Cylinder and 2 x heating zones

- [1] Appliance
- [2] Zone valves
- [3] Hot water cylinder

Sealed primary system - 3-way valve, cylinder and central heating zone:

Typical Y-Plan example

- The cylinder return must be the last connection on the common return pipe to prevent reverse circulation.

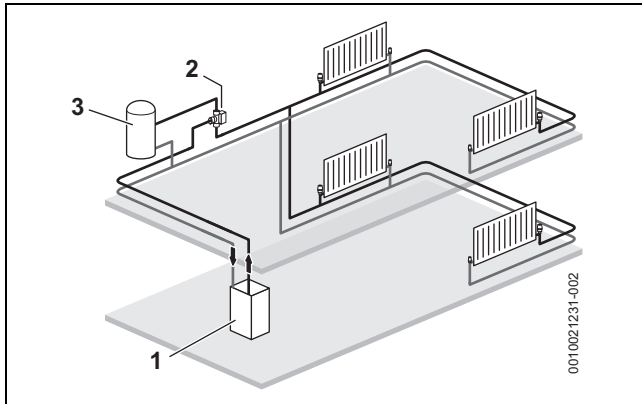

Fig. 8 3-way valve, cylinder and heating zone

- [1] Appliance
- [2] 3-Way zone valve
- [3] Hot water cylinder

Optional integral diverter valve kit

The integral diverter valve kit is designed to operate on a sealed system only. The appliance will require to fit a separate flow and return pipe from the water cylinder to the wall mounting frame and terminate in 15mm copper pipe.

Details for the connection of the integral diverter valve kit components are found within the Installation Instructions for the kit.

Sealed primary system - Internal diverter valve kit:

- This appliance is designed to operate on a sealed system only. The appliance will require a second flow and return pipe from the hot water cylinder to the wall mounting frame and terminate in 15mm copper pipe. The following system layouts show a simplified example of the pipe configuration to the appliance.

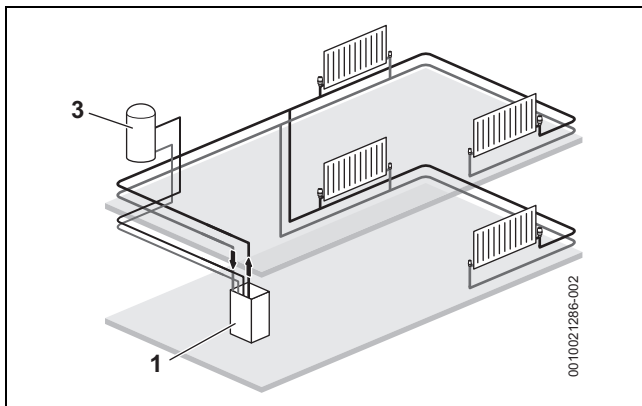

Fig. 9 Example layout - Internal diverter valve kit

- [1] Appliance with internal diverter valve kit
- [3] Unvented hot water cylinder

Unvented cylinders



In all cases the cylinder manufacturer must be contacted for confirmation their product is suitable for the installation layout shown in figure 9.

thermostat supplied with the cylinder, it is possible to use the integral diverter valve kit and not need the 2-port motorised valve to cut the flow of heat to the cylinder to comply with Building Regulation Part G3.

- The integral diverter valve kit cylinder sensor must be used.
- The general layout (figure 9) can be used for unvented cylinders by utilising the high limit thermal cut-out of the cylinder dual-thermostat to interrupt the permanent live to the appliance, preventing any heat being produced by the appliance.

Example layout with unvented cylinder & cylinder safety valve.

If required by the cylinder manufacturer to fit/use the cylinder safety valve then this can also be carried out (figure 10) with the integral diverter valve kit.

- The cylinder safety valve and dual-thermostat (control thermostat and high limit thermal cut-out) are wired to interrupt the permanent live to the appliance, preventing any heat being produced by the appliance.

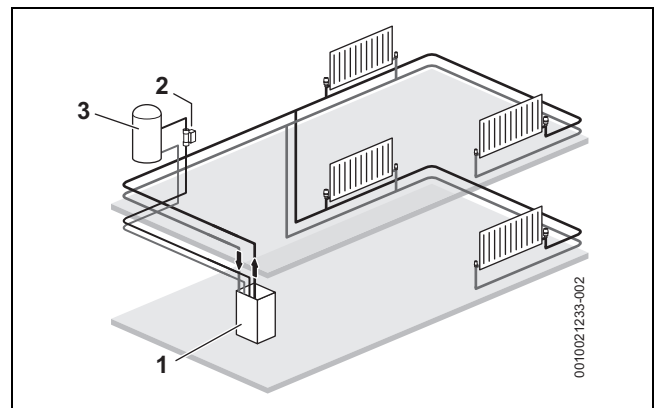

Fig. 10 Example layout - Internal diverter valve kit with unvented cylinder and cylinder safety valve

- [1] Appliance with internal diverter valve kit
- [2] Cylinder safety valve (unvented cylinder)
- [3] Unvented hot water cylinder

4.1.4 System fill

Filling primary sealed systems

NOTICE

Filling the primary sealed system

The system must not be filled with salt based softened water.

► Ensure the primary water filling point uses an untreated cold water connection from the mains supply, before a water softener.

- Filling the system must comply with one of the following methods shown.
- The filling point must be at low level and must never be a permanent connection to the mains water supply.
- Filling loops must be WRAS approved.
- If the external filling link is sited away from the appliance, then a pressure gauge should be installed at the filling point.



The pressure shown on the gauge may differ from that shown on the digital display. Final system pressure adjustments must be made whilst referencing the digital display.

External filling loop

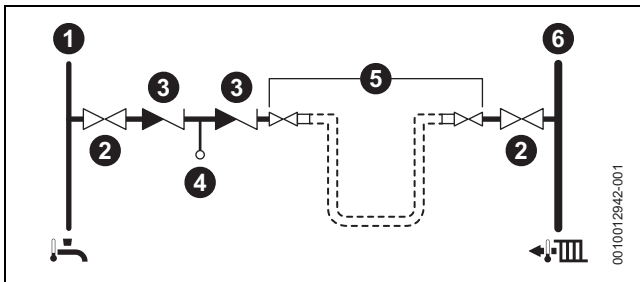

Fig. 11 External filling loop system fill example

- [1] Cold mains inlet pipe
- [2] Stop valve
- [3] Check valve
- [4] Test point
- [5] Hose union
- [6] Central heating flow pipe

4.2 Mains supply

4.2.1 Electrical supply

- Supply: 230V AC - 50 Hz
- This appliance must **not** be connected to a three phase supply.
- The wiring between the appliance and the electrical supply must comply with the latest IET wiring regulations that apply to wiring a fixed appliance for Class 1 equipment.
- The correct type of RCD must be employed where additional protection is required that is suitable for a low energy DC modulating pump according to IET wiring regulations.
- External 3 A fuse to BS1362.
- The appliance must be earthed.
- Cable: PVC insulated 0.75mm² (24 x 0.2mm) temperature rated to 90 °C, to BS EN50525.
- Any additional components that are connected to the appliance with mains electrical supply must not have a separate supply.
- Additional equipment wired to the appliance must comply with the latest IET wiring regulations.
- Appliance protection rating - IPX4D
- When using a control Key product the boiler rating is maintained at IPX4D.

4.2.2 Gas supply

- Appliances using Natural Gas (NG) must be connected to a governed meter.
- Appliances using Liquid Petroleum Gas (LPG) must be connected to a regulator.
- Installation and connection of the gas supply to the appliance must be in accordance with the latest version of BS6891.
- Gas pipe sizing should be calculated to ensure no more than the permitted mbar drop between the meter/governor to the appliance inlet (→ chapter 6).
- The meter or regulator and its pipework must be checked, preferably by the gas supplier. This is to ensure that the equipment is in good working order and can meet the gas flow and pressure requirements, in addition to the demand from any other appliance being served.

Pipe sizing (NG & LPG)



Gas pipework:

- Gas installation pipework must be designed to ensure the pressure loss between the meter outlet (NG) or storage and regulator (LPG) and the inlet to each appliance does not exceed 1mbar (NG) 2.5mbar (LPG) (→ table 21 "Allowed mbar pressure drop").

Basic pipe sizing calculation



Basic pipe sizing calculation.

- **This method is only an estimate - for more complex design please refer to latest version of BS6891 and training given in ACS.**

Natural Gas (NG):

Discharge rates for copper tube with 1mbar differential pressure between the ends for Natural Gas.

Discharge rates for Natural Gas (m ³ /hr) with straight horizontal copper tube					
Pipe length (m)	Discharge m ³ /hr	Pipe size (mm)			
		15	22	28	35
3		2.9	8.7	18	32
6		1.9	5.8	12	22
9		1.5	4.6	9.4	17
12		1.3	3.9	8	15
15		1.1	3.4	7	13
20		0.95	2.9	5.9	11
25		0.92	2.5	5.2	9.5
30		0.88	2.3	4.7	8.5

Table 9 Natural Gas (NG)



Natural Gas:

- When using this table to estimate the gas flow rate in pipework of a known length, the effective length will be increased by 0.5m for each 90° elbow and tee fitted and by 0.3m for each 45° bend.

Liquid Petroleum Gas (LPG):

Discharge rates for copper tube with 2.5mbar differential pressure between the ends for LPG.

Tubing length (m)	Discharge rates for LPG (m ³ /hr & kW) with straight horizontal copper tube					
	Outside diameter					
	15mm		22mm		28mm	
	kW	m ³ /hr	kW	m ³ /hr	kW	m ³ /hr
3	38.4	1.49	207	8.01	412	15.92
6	26.1	1.01	135	5.21	230	8.86
9	20.5	0.79	108	4.19	215	8.33
12	17.9	0.70	94	3.62	187	7.25
15	15.5	0.60	82	3.20	168	6.51
18	13.5	0.53	74	2.86	145	5.61
21	12.9	0.50	67	2.58	135	5.24
24	12.0	0.47	61	2.58	126	4.87

Table 10 Liquid Petroleum Gas (LPG)



Liquid Petroleum Gas (LPG):

- ▶ When using this table to estimate the Gas flow rate in pipework of a known length, the effective length will be increased by 0.6m for each 90° elbow or tee and by 0.3m for each 45° bend or straight coupler.

4.3 Appliance location and clearances

4.3.1 Appliance location

- Follow local regulations for the location within the property that the appliance is to be installed.
- This appliance is only suitable for installing internally within a property at a suitable location onto a flat, fixed rigid surface capable of supporting the appliance weight.
- The appliance is not suitable for external installation.
- Protect installation area against dust and moisture.



No surface protection is required against heat transfer from the appliance.



DANGER

Danger from explosive and flammable materials:

Storage of explosive and flammable materials.

- ▶ Do not store flammable materials (paper, curtains, clothing, primer, paint, ...) in proximity to the appliance.



DANGER

Danger to life from explosion!

An increased and permanent ammonia concentration may lead to stress corrosion cracking on brass (e.g. gas valves, union nuts). As a result, there is a risk of explosion from gas escaping.

- ▶ Do not use wall mounted gas boilers in rooms where there is an increased or permanent ammonia concentration (e.g. livestock stables or storage room for fertilisers).
- ▶ If contact with ammonia is unavoidable, make sure that there are no brass parts installed in the system.

NOTICE

Damage to appliance:

Contaminated combustion air.

- ▶ Do not use any cleaners containing chlorine or hydrogen halide (i.e. spray cans, primers, cleaners, paint and glue).
- ▶ Do not store or use these substances in the appliance or room.
- ▶ Avoid the build-up of dust.

NOTICE

Damage to appliance:

Extreme temperatures may cause damage to the heating system.

- ▶ Ensure the appliance location's ambient temperature is above 0 °C and below 50°C.

NOTICE

Damage to system:

The heating system pipework can be damaged by frost if installed in an internal unheated area, such as a loft, basement or garage.

The appliance internal frost protection only monitors the system water temperature within the appliance to provide protection for the appliance.

- ▶ Install a frost thermostat and pipe thermostat connected in series, to protect the system pipework.
We recommend that the frost thermostat is sited in the coldest unheated area in which pipework is located and that it is set to call for heat at 5 °C. The Pipe stat should be located on whichever pipe is furthest from the heated area where warmer water will be drawn from considering the direction of flow, and set to end the demand at 15 °C.
- ▶ The system pipework in the internal unheated area should be insulated.
- ▶ If the appliance is to be shut down for an extended period, drain the central heating system.



Frost protection can also be achieved for systems with Worcester weather compensating controls installed.



The appliance must be installed where:

- ▶ The area is well lit, allowing users to clearly see the appliance to carry out any work or checks.
- ▶ An engineer can gain clear and safe access to work on the product or component, including making adequate provision for visual inspection of flues in voids.
- ▶ The homeowner can gain clear and safe access to the controls or to check, top up or reset the appliance.
- ▶ Roof space installations must fully conform to BS 5410 part 1: roof space installations.
- ▶ Products in roof spaces must have permanent fixed lighting, a permanent fixed retractable ladder and a fixed floor area sufficient to allow access for normal use and servicing around the product and between the product and the access hatch.
We would also recommend that a remote pressure gauge and filling loop are sited where the customer can gain easy access to assist with checking and topping up.

4.3.2 Rooms containing a bath or shower

CAUTION

Risk of electric shock

► Any switch or appliance control using mains electricity must not be within reach of a person using the bath or shower.

- In all cases the installation **must be in accordance with the latest amendments to the latest edition of the IET Wiring Regulations (BS7671)**.
- Check the IP rating of any control units to be used on this appliance.
- Circuit breaking devices should be used in accordance with the regulations.
- Figure 12 is for guidance only.

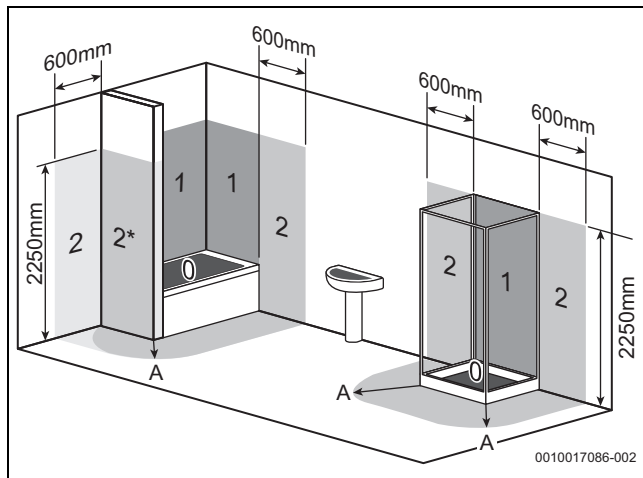

Fig. 12 Bathroom installations

- [0] Zone 0
- [1] Zone 1
- [2] Zone 2
- [2*] Without the end wall, zone 2 must extend 600mm from the bath
- [A] 600mm radius from the bath or shower

- Appliance protection rating - IPX4D
- When using a control Key product the boiler rating is maintained at IPX4D.

4.3.3 Appliance clearances

- The following details cover the installation, service and maintenance clearances for the appliance.

CAUTION

Risk of damage to appliance or property

The appliance will overheat if the clearance space around the appliance is restricted by objects.

- Do not restrict this space with the addition of cupboards, shelves etc. next to or around the appliance.
- Do not store any combustible materials on or next to the appliance, such as clothes, towels, paper or plastic bags.

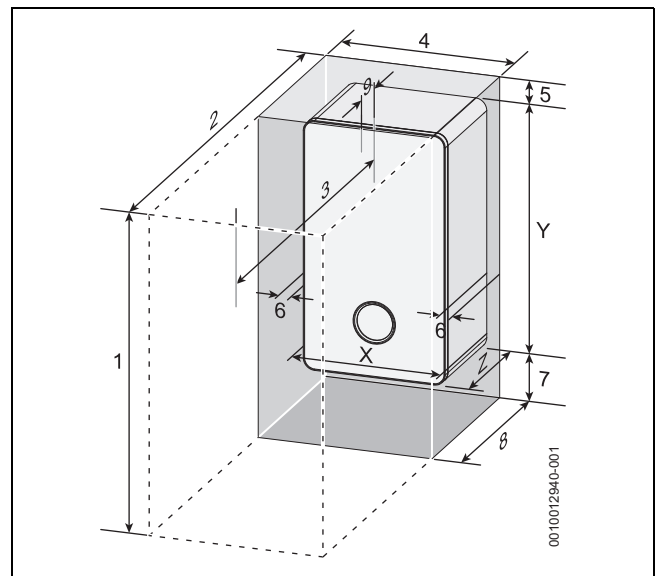

Fig. 13 Appliance minimum clearances

Minimum clearances		
	Description	Dimensions (mm)
X	Appliance width	400
Y	Appliance height	724 ¹⁾
Z	Appliance depth	310
Installation/Maintenance		
1	Overall clearance height	1,080/1,120 ²⁾
2	Overall clearance depth	760/910 ³⁾
3	In front of appliance	450/600 ³⁾
4	Overall clearance width	410
5	Above the appliance	170/210 ²⁾
6	Either side of appliance	5
7	Below the appliance	186
8	Compartment depth	330
9	Appliance to removable door	20

- 1) 724mm to middle of top panel. 710mm side panel height. Bottom panel is removable and not part of minimum clearance height requirements.
- 2) Height for either 60/100 flue or 80/125 flue.
- 3) Front clearance can be reduced by 150mm, refer to the advice given in Reduced front maintenance minimum clearances.

Table 11 Appliance minimum clearances

Reduced front maintenance minimum clearances

The front servicing clearance for this appliance can be reduced to 450mm.

For installations with a front servicing clearance less than 600mm (minimum of 450mm), the following additional criteria must be achieved.

- The bottom of the appliance case must be between 1000mm and 1500mm from the floor.
- There must be at least 450mm clearance in front of the appliance to floor level. Anything sited below the appliance must not protrude into this clear space.
- There must be at least 186mm clearance to any structure which is sited below the appliance.
- There must be at least 300mm clear space to either the left hand or right hand side of the appliance. This clear space must be from the required clear height above the appliance to floor level.
 - This clearance will not apply if the appliance is sited within 300mm of a door way and the door frame is the only obstruction.



Minimum clearances must be observed to any obstruction/ surface, (dark shaded areas, figures 14 and 15).

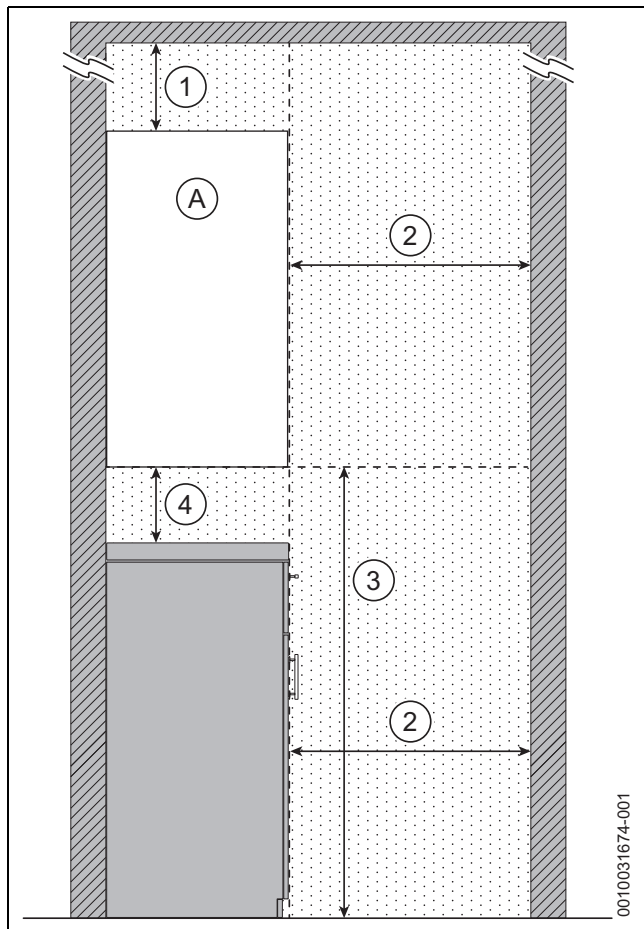

Fig. 14 Reduced front maintenance clearances - Side view

- [A] Appliance.
- [1] Above appliance - Same clearance required as for standard clearances of 60/100 flue or 80/125mm flue.
- [2] In front of appliance - Minimum 450mm.
- [3] Bottom of appliance to the floor - 1,000 - 1,500mm.
- [4] Below appliance - 186mm

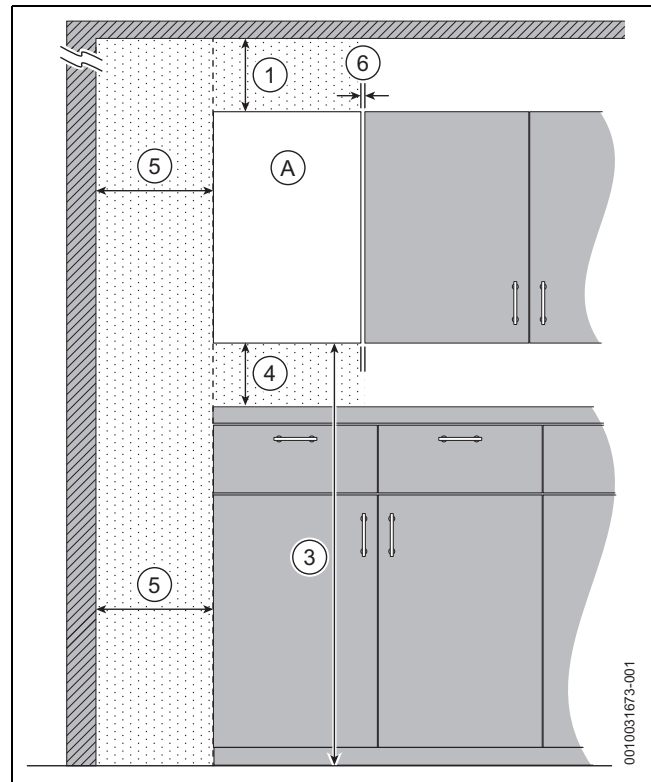

Fig. 15 Reduced front maintenance clearances - Front view

- [A] Appliance.
- [1] Above appliance - Same clearance required as for standard clearances of 60/100 flue or 80/125mm flue.
- [3] Bottom of appliance to the floor - 1,000 - 1,500mm.
- [4] Below appliance - 186mm
- [5] One side of appliance - Minimum 300mm.
- [6] One side of appliance - Minimum 5mm.

Appliances in compartments

Follow the latest requirements of BS6798 and BS5440 and note:

- Minimum clearances must be maintained.
- An access door is required to install, service and maintain the appliance and any ancillary equipment.
- If the appliance is installed in an unventilated airing/storage cupboard, there is no requirement to make a partition between the appliance and the storage space as long as the minimum clearances around the appliance are maintained.

4.4 Flue systems considerations

WARNING

Flue systems

Possible flue gas escape

- ▶ Use Worcester, Bosch Group approved Condensfit II flue systems only, no other manufacturer’s flue have been tested or approved for use with Worcester, Bosch Group appliances.



CAUTION

Concealed flue systems:

- ▶ Where a flue system is going to be concealed, provision must be made for service and inspection.
- ▶ Voids containing concealed flues must have at least one inspection hatch no less than 300mm square.
- ▶ Flue joints within the void must not be more than 1.5 metres from the edge of the inspection hatch.
- ▶ Inspection hatches should be located at changes of direction.
- ▶ If this is not possible, bends should be viewable from both directions.



Refer to the manual supplied with the Worcester, Bosch Group flue kit for complete installation instructions.

Flue kit part numbers

Part number	Flue Ø	Description
7 733 601 245	60/100	4000 SimpleSwitch flue adaptor 60/100
7 716 191 082	60/100	Telescopic horizontal flue kit
7 716 191 171	60/100	Extended telescopic horizontal flue kit
7 733 600 048	60/100	Horizontal high level telescopic flue kit
7 719 003 702	80/125	Telescopic horizontal flue kit
7 719 002 430	60/100	Vertical balanced flue kit
7 719 002 431	80/125	Vertical balanced flue kit
7 733 600 298	60/100	1050mm horizontal fixed flue kit

Table 12 Flue kit assembly part numbers

4.4.1 Flue length

Maximum horizontal flue lengths

Appliance	Flue length [L]	
	60/100	80/125
GR4700iW 24 S	12,000mm	21,000mm
GR4700iW 21 S	12,000mm	21,000mm
GR4700iW 18 S	12,000mm	21,000mm
GR4700iW 15 S	16,000mm	20,000mm
GR4700iW 12 S	16,000mm	20,000mm

Table 13 Maximum flue lengths - Horizontal flues

Maximum vertical flue lengths

Appliance	Flue length [L]	
	60/100	80/125
GR4700iW 24 S	12,000mm	21,000mm
GR4700iW 21 S	12,000mm	21,000mm
GR4700iW 18 S	12,000mm	21,000mm
GR4700iW 15 S	16,000mm	20,000mm
GR4700iW 12 S	16,000mm	20,000mm

Table 14 Maximum flue lengths - Vertical flues

Flue system bends

NOTICE

Effective flue lengths of bends:

Each bend used has an equivalent straight flue length.

- ▶ Refer to table 15.

Bend	Effective flue length	
	60/100	80/125
45°	0.5m	0.5m
90°	1.5m	1.5m

Table 15 Effective length of bends

NOTICE

Effective flue length of SimpleSwitch flue adaptor:

The SimpleSwitch flue adaptor has an equivalent straight flue length.

- ▶ Refer to table 16.

	Effective flue length	
	60/100	80/125
	4m	N/A

Table 16 Effective length of SimpleSwitch flue adaptor

4.4.2 Flue options

The systems have different maximum flue lengths, refer to the following example flue options for those maximum flue lengths.

Horizontal high level flue assembly

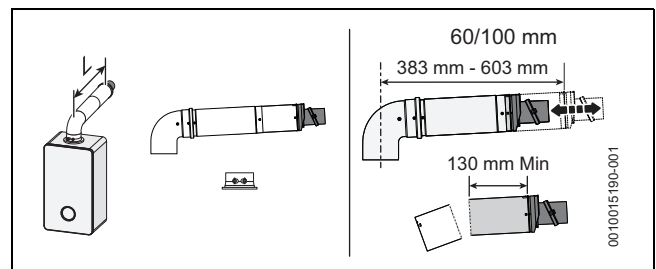

Fig. 16 Horizontal flue option

- Flue length [L] (initial bend included in length calculation)
 - 60/100 = 202 - 603mm
 - 80/125 = N/A

Telescopic horizontal flue assembly

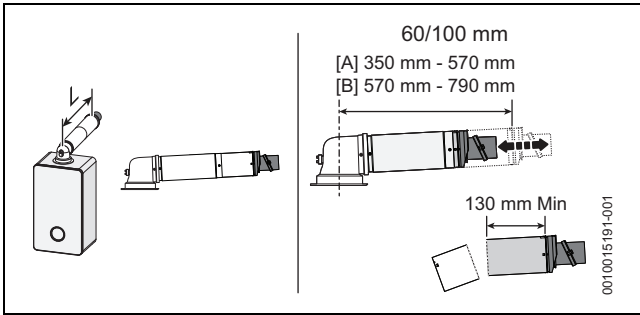

Fig. 17 Horizontal flue option

Telescopic horizontal flue assembly [A]

- Flue length [L] (adaptor bend included in length calculation)
 - 60/100 = 180 - 570mm
 - 80/125 = 405 - 600mm

Extended telescopic horizontal flue assembly [B]

- Flue length [L] (adaptor bend included in length calculation)
 - 60/100 = 570 - 790mm
 - 80/125 = N/A

Horizontal fixed length flue assembly

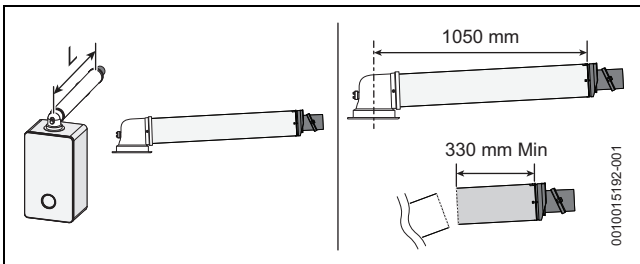

Fig. 18 Horizontal flue option

- Flue length [L] (adaptor bend included in length calculation)
 - 60/100 = 330 - 1,050mm
 - 80/125 = N/A

Extended horizontal flue

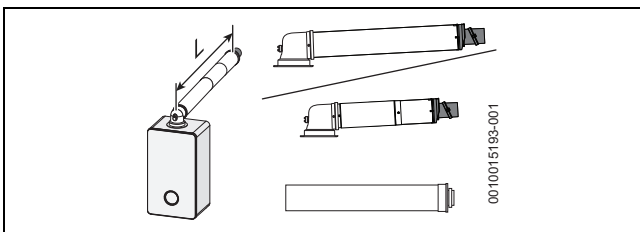

Fig. 19 Horizontal flue option

- Flue length [L] (adaptor bend included in length calculation)
 - Maximum flue length as stated in "Maximum horizontal flue lengths".

Horizontal flue with additional 90° elbow

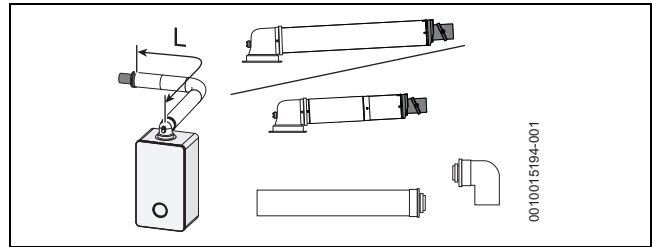

Fig. 20 Horizontal flue option

- Flue length [L] (adaptor bend included in length calculation)
 - Maximum flue length as stated in "Maximum horizontal flue lengths" minus the 90° bend equivalent straight flue length as stated in Table 15 "Effective length of bends".

Horizontal flue with additional 90° elbows

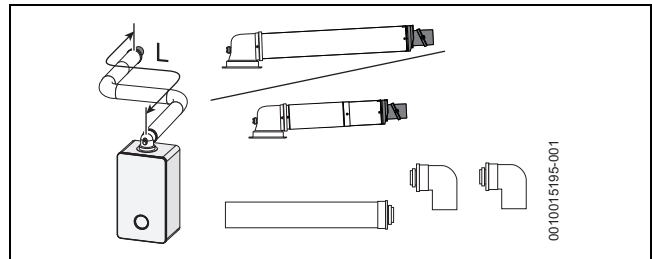

Fig. 21 Horizontal flue option

- Flue length [L] (adaptor bend included in length calculation)
 - Maximum flue length as stated in "Maximum horizontal flue lengths" minus 2 x 90° bends equivalent straight flue length as stated in Table 15 "Effective length of bends".

High level horizontal flue

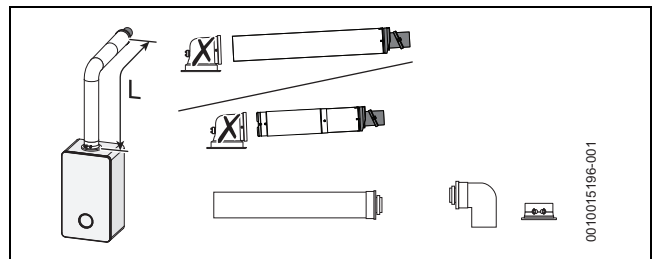

Fig. 22 Horizontal flue option

- Flue length [L] (initial bend included in length calculation)
 - Maximum flue length as stated in "Maximum horizontal flue lengths".

High level horizontal flue with additional 90° elbow

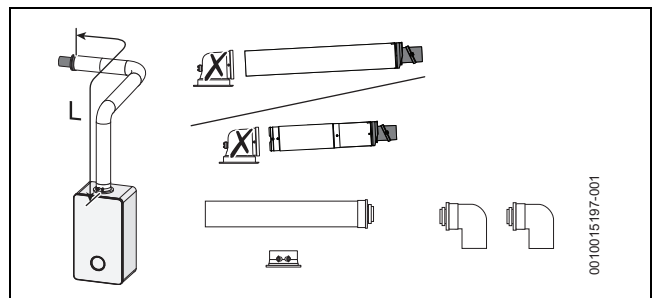

Fig. 23 Horizontal flue option

- Flue length [L] (initial bend included in length calculation)
 - Maximum flue length as stated in "Maximum horizontal flue lengths" minus the 90° bend equivalent straight flue length as stated in Table 15 "Effective length of bends".

High level horizontal flue with additional 90° elbows

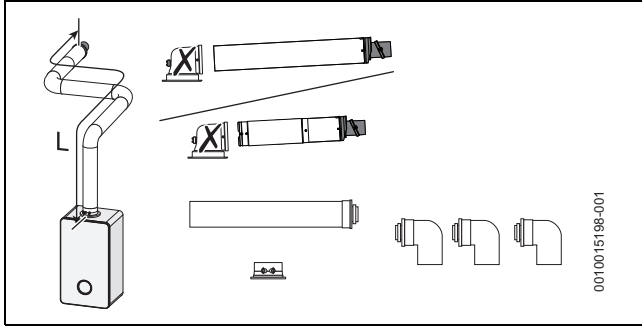

Fig. 24 Horizontal flue option

- Flue length [L] (initial bend included in length calculation)
 - Maximum flue length as stated in "Maximum horizontal flue lengths" minus 2 x 90° bends equivalent straight flue length as stated in Table 15 "Effective length of bends".

SimpleSwitch offset flue adaptor - horizontal

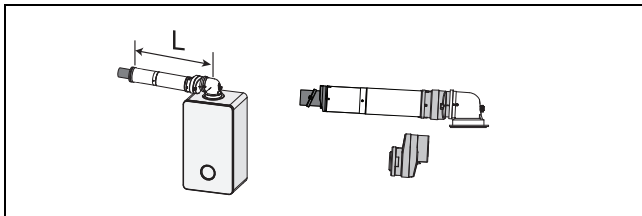

Fig. 25 SimpleSwitch flue adaptor

- Flue length [L]
 - Maximum flue length as stated in "Maximum horizontal flue lengths" minus the equivalent length of the SimpleSwitch flue adaptor as stated in table Table 16 "Effective length of SimpleSwitch flue adaptor".

Vertical balanced flue assembly

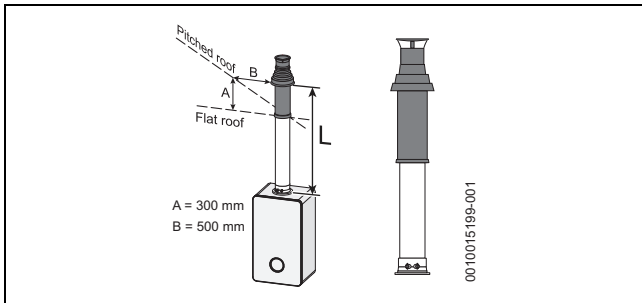

Fig. 26 Vertical flue option

- Flue length [L]
 - Maximum flue length as stated in "Maximum vertical flue lengths".

Vertical balanced flue with 90° elbow offset

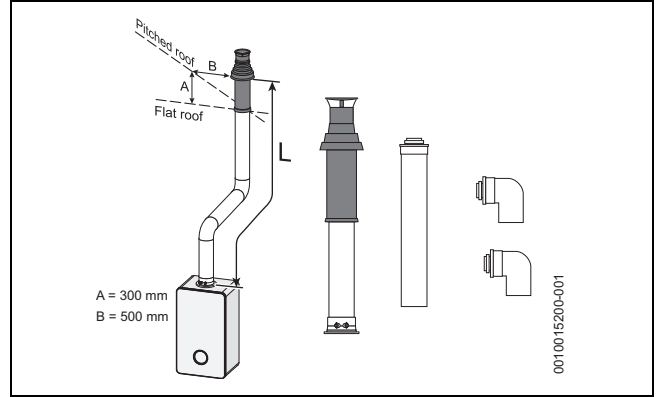

Fig. 27 Vertical flue option

- Flue length [L]
 - Maximum flue length as stated in "Maximum vertical flue lengths" minus 2 x 90° bends equivalent straight flue length as stated in Table 15 "Effective length of bends".

Vertical balanced flue with 45° elbow offset

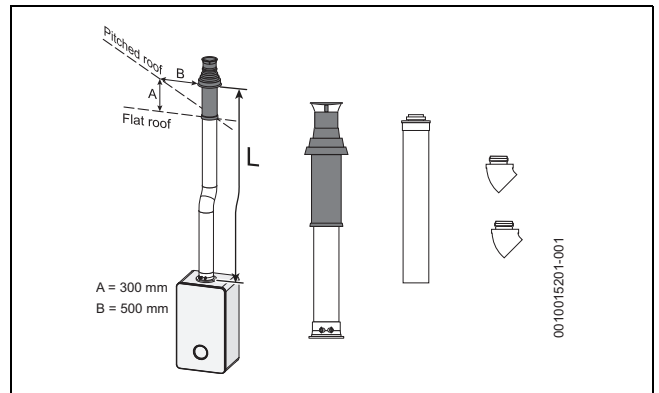

Fig. 28 Vertical flue option

- Flue length [L]
 - Maximum flue length as stated in "Maximum vertical flue lengths" minus 2 x 45° bends equivalent straight flue length as stated in Table 15 "Effective length of bends".

SimpleSwitch offset flue adaptor - vertical

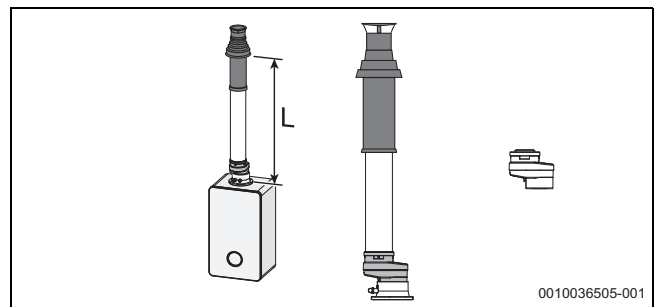

Fig. 29 SimpleSwitch flue adaptor

- Flue length [L]
 - Maximum flue length as stated in "Maximum vertical flue lengths" minus the equivalent length of the SimpleSwitch flue adaptor as stated in table Table 16 "Effective length of SimpleSwitch flue adaptor".

4.4.3 Plume management system

The maximum flue length allowed for 0.5m of plume is 9m, each additional 1m of plume reduces the flue length by 750mm, up to a maximum of 4.5m of plume management with 6m of flue.

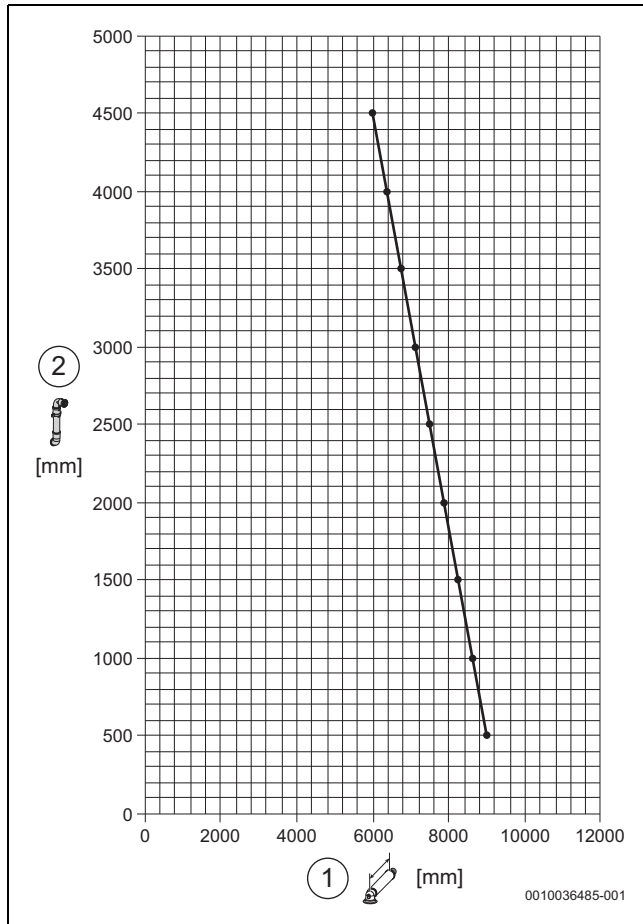

Fig. 30 Plume length to flue length graph

- [1] Flue length [mm] (maximum 9,000mm with minimum 500mm plume)
- [2] Plume length [mm] (maximum plume length 4,500mm)

NOTICE

Plume management terminal:

- ▶ The plume management terminal must not be sited within 500mm of the air intake, and must not exceed the maximum straight length for a horizontal Ø 60/100mm flue with a 60mm plume management system.



Horizontal plume management runs

- ▶ The initial horizontal run from the terminal elbow must have a minimum 10° fall back, (stop tabs in the elbow prevent less than 10°) to the appliance for proper disposal of condensate.
- ▶ Any further horizontal runs after an elbow can be 3°.

WARNING

Minimum plume management length:

The minimum distance of 500mm must be maintained between air inlet and exhaust.

- ▶ Do not terminate the plume management inside the terminal exclusion zone (shaded area) shown in figure 31.

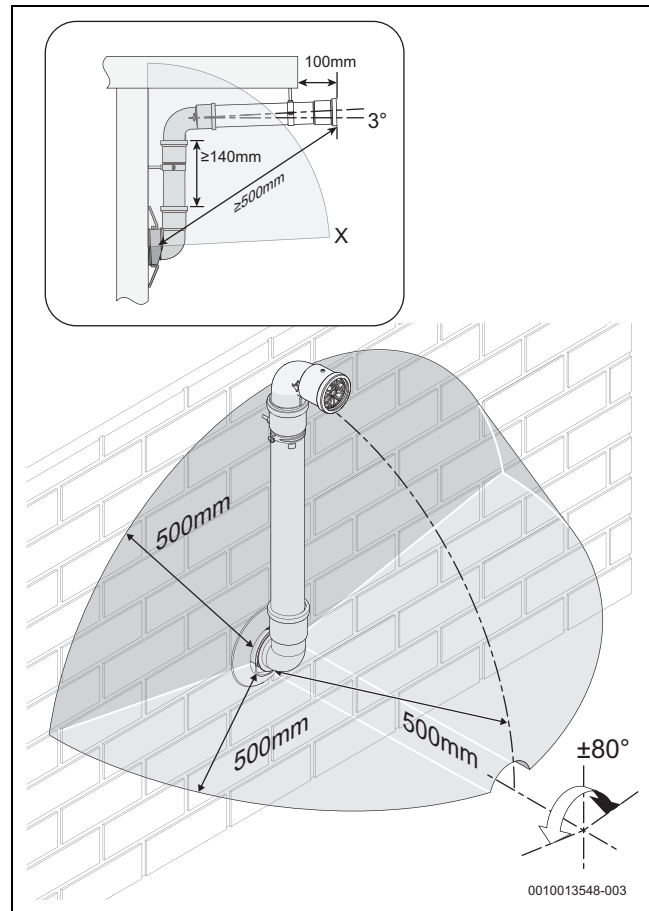

Fig. 31 Terminal exclusion zone

NOTICE

Cutting the 500mm pipe

- ▶ The Plume management extension kit contains the components required for such a configuration.

Plume management bends

NOTICE

Effective plume management lengths of bends:

Each bend used has an equivalent straight plume management length.

- ▶ Refer to the table 17.

Bend	Effective plume management length
45°	0.75 metres
90°	1.5 metres

Table 17 Effective length of bends

4.4.4 Flue terminal positions

CAUTION

Flue terminal positions

- ▶ All measurements are the minimum clearances required.
- ▶ Terminals must be positioned so to avoid combustion products entering the building.

Vertical flue terminal positions

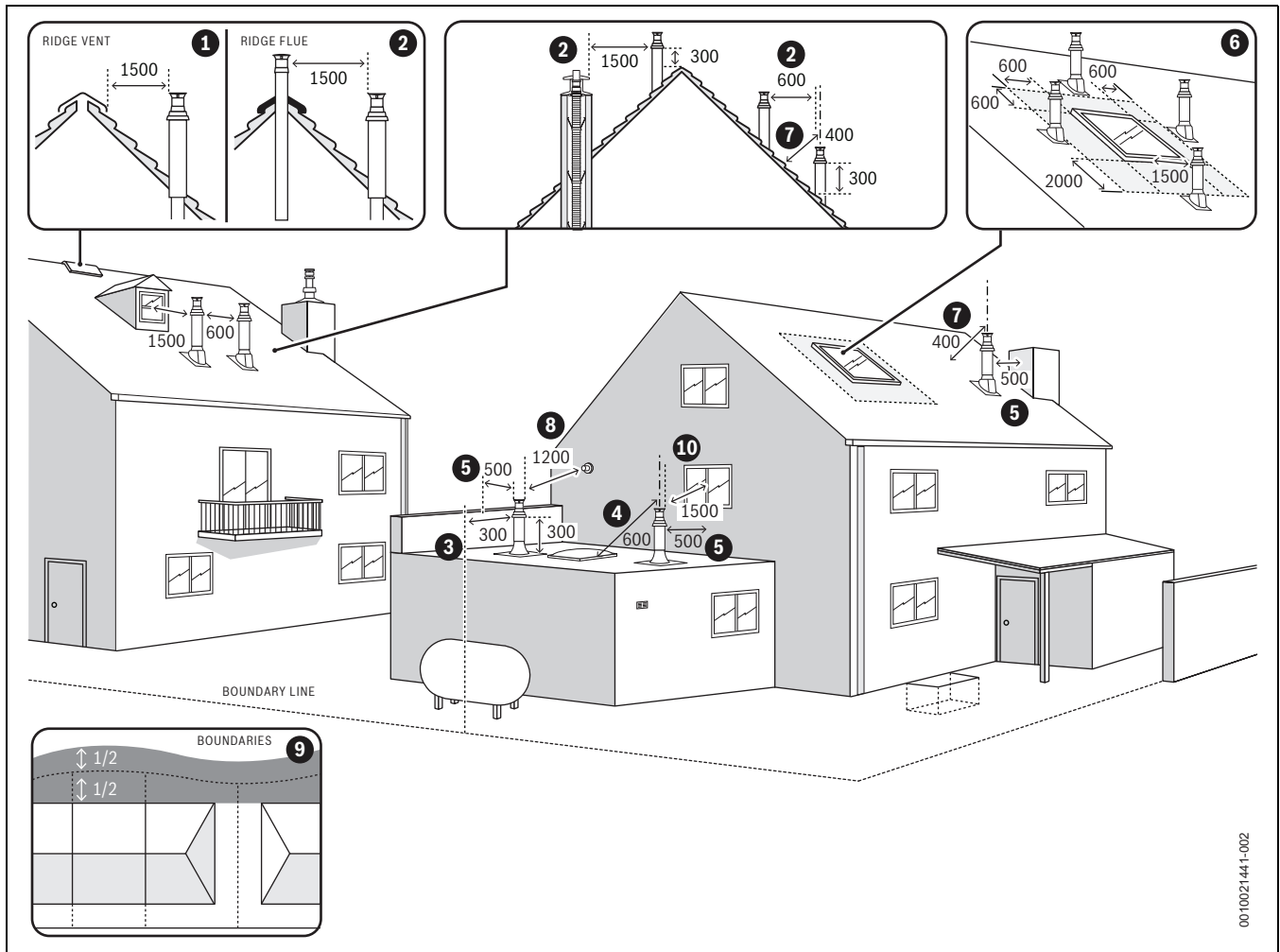

Fig. 32 Vertical flue terminal positions

Key to figure 32:

- [1] 1,500mm measured between a vertical flue terminal and an opening or vented window. 500mm measured horizontally between a vertical flue terminal and an opening or vented window providing the flue terminal is at least 300mm above the opening.
- [2] Minimum clearance to an additional flue, 600mm to a room sealed flue or 1,500mm to an open flue.
- [3] 300mm clearance from a vertical flue terminal adjacent to a boundary line, unless it will cause a nuisance. BS 5440: Part 1 recommends that care is taken when siting a terminal in relation to boundary lines.
- [4] 600mm minimum clearance measured from an opening or vented skylight to a vertical flue terminal. If the terminal is within 1,500mm of the opening or vented skylight then it must be at least 300mm above the opening.
- [5] 500mm clearance measured horizontally from a vertical flue to a vertical structure.
Not required if the terminal is 300mm above the structure.
- [6] The flue must not penetrate the roof in the shaded area. The terminal must be at least 1,500mm from the opening or vent when sited below the window or 600mm when sited to either side or above.
- [7] 400mm measured diagonally from a pitched roof or 500mm in regions with heavy snow fall. 300mm measured vertically from the air intake to the closest intersection with the roof.
- [8] 1,200mm separation measured between a vertical flue and a horizontal flue terminal.
- [9] For the purpose of determining suitable flue terminal positions for gas appliances, the boundary can be considered to extend to the

centre line of any adjacent routes or waterways e.g. paths, streets, rights of way, canals, rivers or railways.

- [10] 1,500mm measured between a vertical flue terminal and an opening or vented window. 500mm measured horizontally between a vertical flue terminal and an opening or vented window providing the flue terminal is at least 300mm above the opening.



Note:

- Where a vertical flue terminates in an area that is enclosed on 3 sides, the flue must be no more than 1,000mm below the lowest roof line. You must ensure that all clearances are maintained and that products of combustion disperse safely from the area.

0010021441-002

Horizontal flue terminal positions

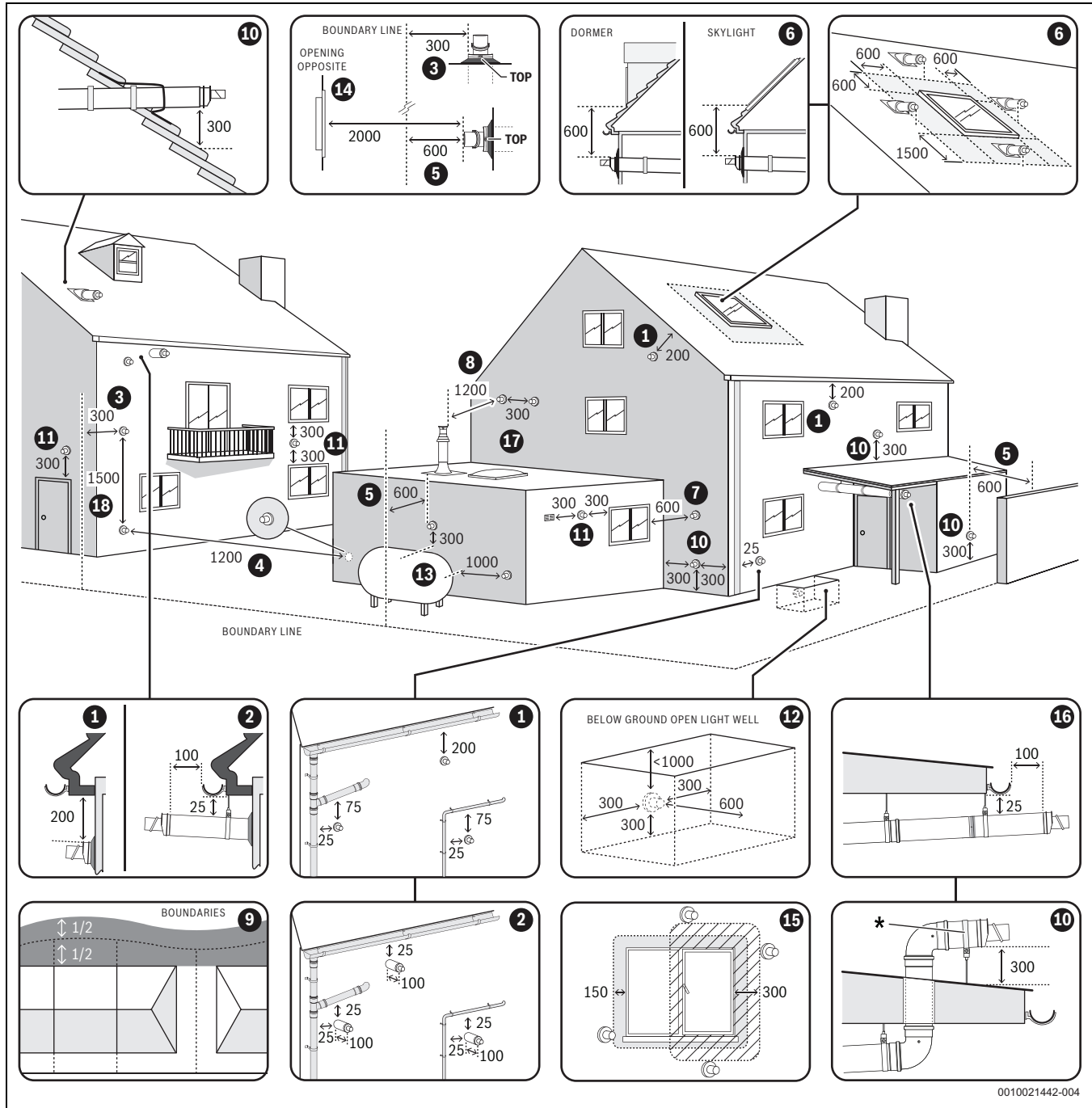

0010021442-004

Fig. 33 Horizontal flue terminal positions

Key to figure 33:

- [1] 200mm below eaves and 75mm below gutters, pipe and drains.
- [2] The dimension below eaves, gutters, pipes and drains can be reduced to 25mm, as long as the flue terminal is extended by 100mm past any overhang. The telescopic flue joint must be sealed with suitable silicone sealant if it is external to the building.
- [3] 300mm adjacent to a boundary line, unless it will cause a nuisance. BS 5440: Part 1 recommends that care is taken when siting terminal in relation to surfaces or boundary lines.
- [4] 1,200mm separation measured between terminals facing each other.
- [5] 600mm distance to a surface or boundary line facing a terminal, unless it will cause a nuisance. BS 5440: Part 1 recommends that care is taken when siting terminal in relation to surfaces or boundary lines.
- [6] The terminal must be at least 1,500mm from the opening or vent when sited below the window or 600mm when sited to either side or above.
- [7] 600mm diagonally to an opening door, air vent or opening window.
- [8] 1,200mm separation measured between a vertical flue and a horizontal flue terminal.
- [9] For the purpose of determining suitable flue terminal positions for gas appliances, the boundary can be considered to extend to the centre line of any adjacent routes or waterways e.g. paths, streets, rights of way, canals, rivers or railways.
- [10] 300mm to an internal or external corner. 300mm above a surface, such as the ground/ floor level or roof surface.
* If the terminal section is less than 150mm and has two screws securing it to the elbow, the terminal section will not require a supporting bracket.
- [11] 300mm above, below and either side of an opening door, air vent or opening window.
- [12] Below ground level in an open lightwell. The flue must be at least 600mm from the opposing surface and have at least 300mm clearance either side and below. The flue terminal must be no more than 1,000mm from the top of the lightwell.
- [13] Flues should clear any LPG storage by 1,000mm horizontally and 300mm above.
- [14] Proximity of flue duct outlet to boundaries, 2,000mm distance to an opening in adjacent building facing a terminal. BS 5440: Part 1 recommends that care is taken when siting terminal in relation to boundary lines.
- [15] 300mm from an opening or vented window, 150mm to a fixed unvented window.
- [16] The dimension below eaves, balconies and car ports can be reduced to 25mm, as long as the flue terminal is extended to clear any overhang. The telescopic flue joint of the terminal must be sealed with suitable silicon sealant if it is external to the building.
- [17] 300mm Horizontally from a terminal on the same wall.
- [18] 1500mm Vertically from a terminal on the same wall.

Note:

- ▶ Installations in car ports are not recommended.
- ▶ The flue cannot be lower than 1,000mm from the top of a light well due to the build up of combustion products.
- ▶ Dimensions from a flue terminal to a fanned air inlet to be determined by the ventilation equipment manufacturer.
- ▶ A flue terminal guard shall be fitted whenever a terminal or air inlet is fitted less than 2,000mm above ground, above a balcony or above a flat roof to which people have access.

4.4.5 Plume re-direct and plume management terminal positions



Maximum and minimum plume management lengths:

- ▶ A minimum distance of 500mm must be maintained between the plume management outlet and the flue air intake.
- ▶ The maximum plume management length is 4.5 metres for the appliances detailed on the front of this manual.
- ▶ The 45° bend is equivalent to 0.75 metres of straight plume management and the 90° bend is equivalent to 1.5 metres.

NOTICE

- ▶ All measurements are the minimum clearances required.
- ▶ Refer to “Horizontal flue terminal positions” for all concentric flue terminal positions unless the flue position is specified in figure 34 “Plume re-direct and plume management terminal positions”.
- ▶ Terminals must be positioned so to avoid combustion products entering the building.
- ▶ Support the flue at approximately one metre intervals and at a change of direction, use suitable brackets and fittings.

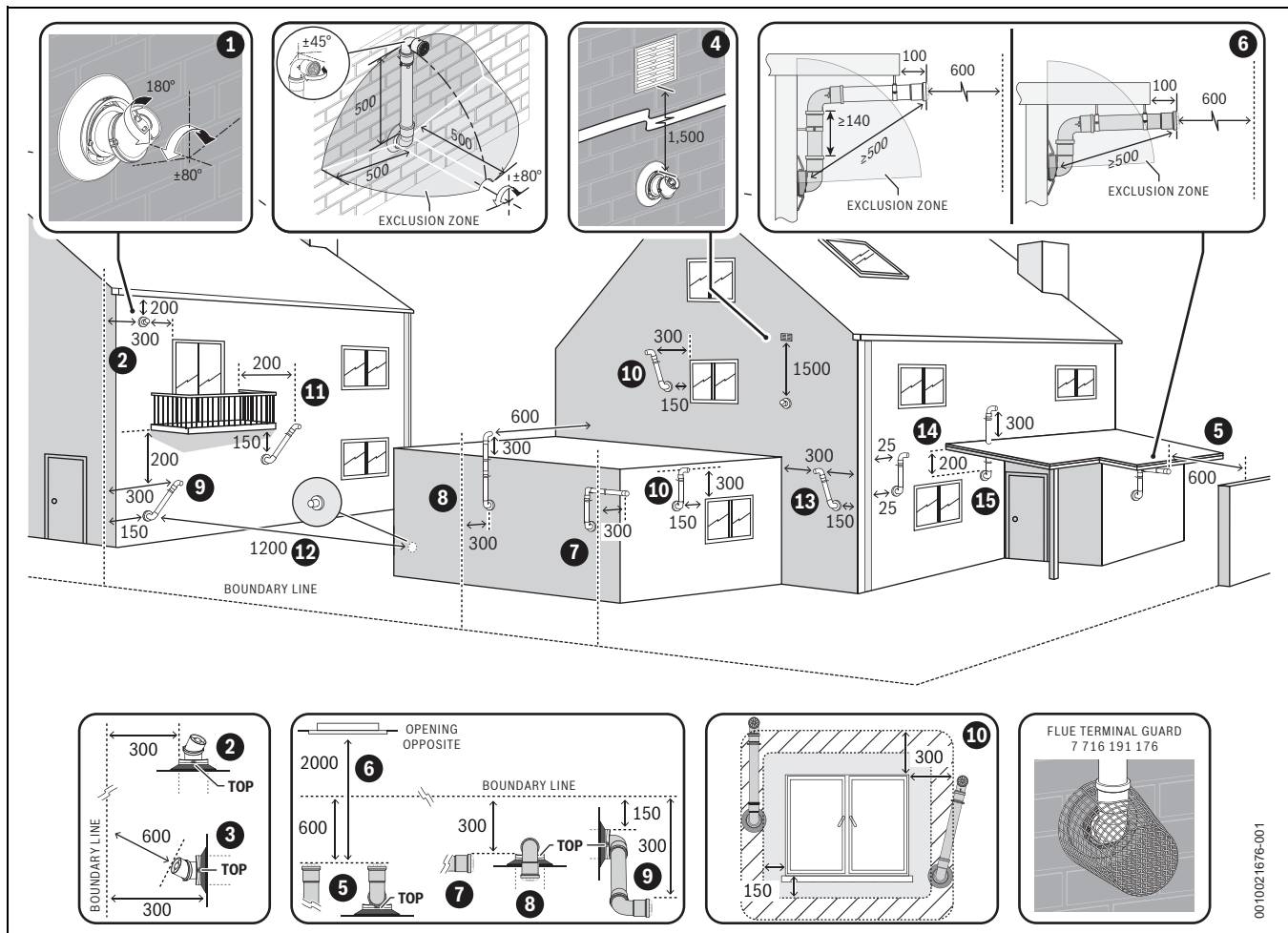

Fig. 34 Plume re-direct and plume management terminal positions

0010021676-001

Key to figure 34
- Plume re-direct terminal positions:

- [1] This feature allows some basic plume re-direction options on a standard telescopic horizontal flue terminal.
300mm minimum clearances to an opening e.g. window.
However the minimum clearances to an opening in the direction that the plume management is facing, must be increased to 1,500mm.
Where the flue is less than 150mm to a drainpipe and plume redirection is used the deflector should not be directed towards the drainpipe.
- [2] 300mm adjacent to a boundary line, unless it will cause a nuisance. BS 5440: Part 1 recommends that care is taken when siting terminal in relation to surfaces or boundary lines.
- [3] Where the flow of products of combustion is not at right angles to the boundary, the 600mm dimension may be measured in the direction of flow as long as the terminal is not less than 300mm from the boundary.
- [4] When redirecting the flue discharge the terminal end must be at least 1,500mm from any opening in the direction of the discharge to prevent combustion products from entering the building.

Key to figure 34
- Plume management terminal positions:

- [5] 600mm distance facing a surface or a boundary line, unless it will cause a nuisance. BS 5440: Part 1 recommends that care is taken when siting a terminal in relation to surfaces or boundary lines.
- [6] Proximity of flue duct outlet to boundaries, 2000mm distance to an opening in adjacent building facing a terminal. BS 5440: Part 1 recommends that care is taken when siting terminal in relation to boundary lines.
- [7] 300mm adjacent to a boundary line, unless it will cause a nuisance. BS 5440: Part 1 recommends that care is taken when siting terminal in relation to surfaces or boundary lines.
- [8] 300mm distance from a boundary line to the air intake as long as the exhaust terminal faces away from the boundary line. The exhaust terminal must have a minimum 300mm clearance to a surface below and there must be at least 600mm clearance when measured horizontally in a straight line from the exhaust terminal to any other surface.
- [9] Plume Management kit air intake can be reduced to 150mm providing the flue exhaust outlet is no less than 300mm adjacent to a boundary line.
- [10] Above, below and either side of an opening door, air vent or opening window.
Using a Plume Management kit the air intake measurement can be reduced to 150mm providing the flue exhaust outlet has a 300mm clearance.
- [11] Below balcony or overhang. The air intake clearance can be reduced to 150mm providing the flue exhaust outlet has a 200mm clearance.
- [12] 1,200mm between terminals facing each other¹⁾.
- [13] Internal/external corners. The air intake clearance can be reduced to 150mm providing the flue exhaust outlet has a 300mm clearance.
- [14] Clearances no less than 200mm from the lowest point of the balcony or overhang.
- [15] If a plume management kit is installed within the confines of a carport or other covered, partially enclosed extension, then the exhaust terminal must be positioned at least 1200mm away from any opening into the building which is sited within the footprint of

1) 600mm in case two plume management kits are used on opposing terminals. Each terminal should use a minimum length of 500mm plume management.

the carport.

If the exhaust terminal is extended at least 300mm beyond the footprint of the carport then the distance from the terminal to an opening within the carport can be reduced to 600mm.

The exhaust terminal can also be routed through the roof of the carport providing 25mm clearance is provided around the flue pipe to any flammable material and that it extends at least 300mm above the roof.

The air intake must have a minimum 150mm clearance to any opening in the building in order to ensure the integrity of the structure is maintained. If the exhaust terminates within the footprint of the carport then the carport must have at least 2 sides completely open. If the exhaust terminates at least 300mm beyond the footprint of the carport then the carport must have at least one completely open side. The exhaust terminal must be positioned to ensure that plume will not cause nuisance or damage to vehicles and that minimum clear distances in front of the terminal will not be impeded by vehicles.



Note:

- ▶ Installations in car ports are not recommended.
- ▶ The flue cannot be lower than 1,000mm from the top of a light well due to the build up of combustion products.
- ▶ Dimensions from a flue terminal to a fanned air inlet to be determined by the ventilation equipment manufacturer.
- ▶ Plume kits running horizontally must have at least a 3° fall back to the appliance for proper disposal of condensate, except for the initial horizontal run from the terminal.
The initial plume kit horizontal run will have at least a 10° fall back to the appliance, due to the terminal elbow design, for proper disposal of the condensate.

4.5 Condensate discharge



Full details on condensate discharge.

- ▶ Follow the latest version of **BS6798** and HHIC guidance.

For correct installation and trouble free operation of the appliance the following advice should be followed:

1. **To minimise the risk of freezing, wherever possible: the condensate drain should be installed internally.**
2. All condensate pipework must 'fall' from the appliance by a minimum of 3° (52mm per metre) to ensure adequate condensate flow.
3. The pipework route must allow air to be supplied back to the appliance for correct operation.
4. Connection to a rainwater down pipe must include an air break.

Also:

- Assessment of the risk of the condensate pipe freezing must be carried out and appropriate precautions taken where necessary. This must take into account the specific site conditions.
- The condensate pipework connected to the condensate drain outlet on the appliance should have a minimum internal diameter (ID) of 19mm.
- Keep external pipework as short as possible. Further precautions against freezing must be taken if external pipe runs exceed 3m.
- External pipework should have a minimum internal diameter (ID) of 30mm.
- Minimise the number of bends and connectors.
- Remove burrs and debris after cutting the pipe.
- Remove surplus solvent from the interior of the pipe.
- The condensate pipework shall be run in standard drainpipe material, e.g. polyvinyl chloride (PVC), unplasticised poly vinyl chloride (PVC-U), acrylonitrilebutadiene styrene (ABS), polypropylene (PP) or chlorinated poly vinyl chloride (PVC.C).

4.5.1 Appliance siphonic condensate trap

The appliance has a large capacity condensate trap reducing the risk of condensate discharge pipework freezing up in prolonged cold temperatures.

The expanded siphonic operation discharges every 10 to 20 minutes. Resulting in:

- Increased velocity and flow rate.
- With less frequent siphonic actions per hour, the condensate pipework is empty for longer.
- Significantly reducing freezing potential for a 48 hour period at -15 °C, provided the installation parameters listed below are followed.

4.5.2 Condensate pipework

NOTICE

General consideration

- ▶ Where a new or replacement appliance is being installed, access to an internal "gravity discharge" point should be one of the factors considered in determining appliance location.
- ▶ Condensate pipe connection at the appliance:
The condensate pipe must have a nominally outside diameter of 22mm plastic pipe.
- ▶ Ensure there are no blockages in the pipe run.
- ▶ Ensure that the discharge method for the installation can effectively handle the condensate waste from the appliance.

Condensate pipework - Unheated internal areas

NOTICE

Unheated internal areas.

Although the large volume siphon will reduce the risk of freezing, condensate discharge may freeze in exposed areas during prolonged cold temperatures.

- ▶ Internal pipe runs in unheated areas such as lofts, basements and garages should be treated as external runs.
For additional information refer to "External Connections" section 4.5.4.

4.5.3 Internal connections



Good Practice

- ▶ The following guidance indicates the good practices that must be maintained for the Installation and Maintenance of a product.

Soil stack connection

→ Figure 35

In order to minimise risk of freezing during prolonged cold spells, the following methods of installing condensate drainage pipe should be adopted.

Wherever possible, the condensate drainage pipe should be routed and terminated so that the condensate drains away from the appliance under gravity to a suitable internal foul water discharge point such as an internal soil and vent stack. A suitable permanent connection to the foul waste pipe should be used.

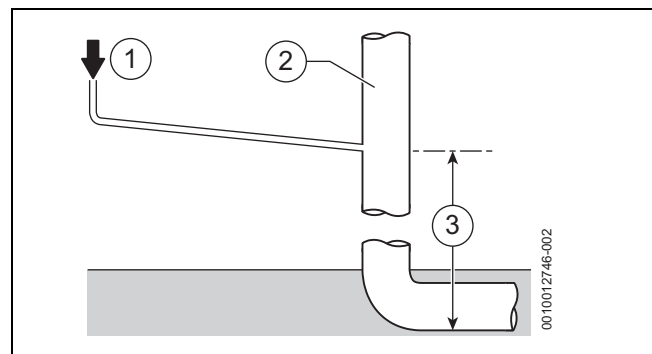

Fig. 35 Disposal to soil vent stack

- [1] Condensate discharge from appliance
- [2] Soil and vent stack
- [3] Minimum 450mm and up to 3 storeys

Waste pipe connection

→ Figure 36

Alternatively if the first option is not possible an internal kitchen, bathroom or washing machine waste pipe etc. can be used. Ensure that the condensate drain pipe is connected “down stream” of the waste trap and that the condensate drain enters into the top of the pipe using a swept tee.

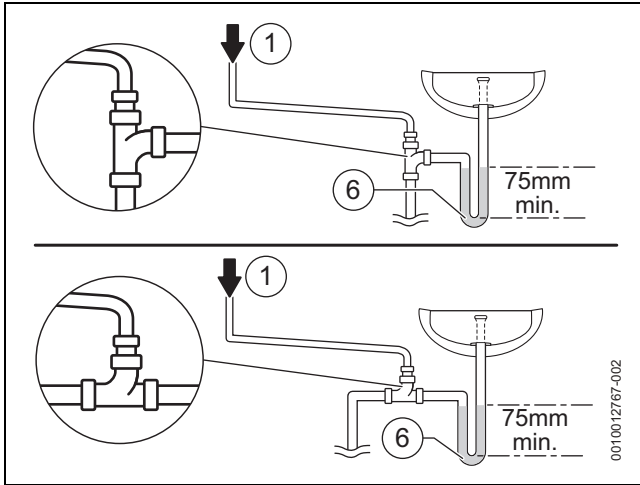

Fig. 36 Waste pipe disposal

- [1] Condensate discharge from appliance
- [6] 75mm sink waste trap

Condensate pump

→ Figure 37

Where direct connection to “gravity discharge” pipework is not physically possible, or where very long internal runs would be required to reach a suitable discharge point, condensate should be removed using a proprietary condensate pump, of a specification recommended by the condensate pump manufacturer.

- The pump outlet should discharge to a suitable “gravity discharge” outlet.
 - The condensate then flows, by gravity, through the 22mm plastic pipe to the condensate discharge point.

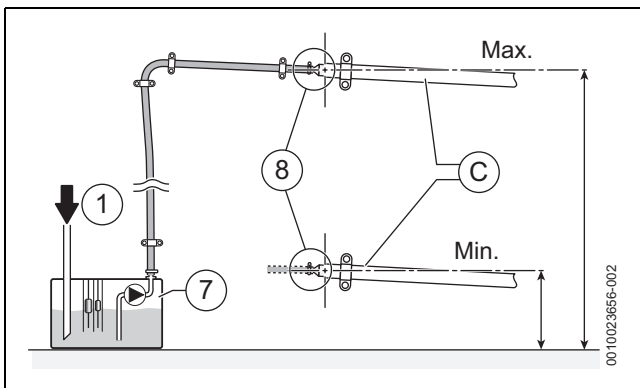

Fig. 37 Condensate pump example

- [1] Condensate discharge from appliance
- [7] Condensate pump
- [8] Pipework transition
- [C] Gravity discharge pipework



Proprietary condensate pump

- ▶ Ensure minimum and maximum pump lifting heights are followed as per condensate pump manufacturers instructions.

4.5.4 External connections

NOTICE

Septic tanks

Untreated condensate must not be allowed into septic tanks.

- ▶ Connection to systems which drain into a septic tank should be avoided due to the risk of affecting anaerobic bacteria.

NOTICE

Rainwater down pipe or external drain disposal

Untreated condensate must not be allowed to flow into streams or rivers.

- ▶ A rainwater down pipe or an external drain shall only be used for condensate disposal if the down pipe or external drain is connected to a combined foul and rainwater drainage system.
- ▶ Refer to BS 6798 for more information on condensate disposal.

NOTICE

Grey water recovery system

Contamination of recovered water

- ▶ Condensate disposal shall not be allowed into a grey water recovery system that is intended for re-use.

External disposal considerations

NOTICE

Freezing conditions

Frozen condensate will block the condensate drain pipe and stop the appliance from running.

- ▶ Pipe lengths should be kept to a minimum and routed as vertically as possible.

NOTICE

Condensate waste disposal

- ▶ Care should be taken when siting a soak-away to avoid causing damage to existing services and building footings.

If no other discharge method is possible then the use of an externally run condensate drainage pipe terminating at a suitable foul water discharge point, or purpose-designed soak away, may be considered. If this method is chosen then the following measures should be adopted:

- ▶ The external run be kept as short as possible and ideally should not exceed three metres. Additional precaution against freezing must be taken if the external pipe run does exceed three metres.
- ▶ The pipe should be run internally as far as possible before going externally and the pipe diameter should be increased to a minimum internal diameter (ID) of 30mm before it passes through the wall to the exterior.
- ▶ The hole through the wall for the condensate pipe should be sleeved and be sealed to the building fabric on the internal and external face using a suitable building material.
- ▶ The external pipe should take the shortest and least exposed route to the discharge point, and should “fall” as steeply as possible away from the appliance, with no horizontal runs in which condensate might stand.
- ▶ The use of fittings, elbows etc. should be kept to a minimum and any internal burrs on cut pipework should be removed so that the internal pipe section is as smooth as possible.
- ▶ All external pipe drainage will be improved if the end is cut at 45° as opposed to a straight cut.

- ▶ In situations where there are likely to be extremes of temperature or exposure, the use of a proprietary trace-heating system for external pipework, incorporating an external frost thermostat, should be considered. All other guidance above and the instructions for the trace heating system, should be closely followed.
- ▶ As well as trace heating, other methods for protecting pipework that are run externally should be considered to prevent freezing during prolonged cold periods.
 - Insulation materials can be used, these should be of class “O” grade with an outer coating that is weather proof and have a UV resistant finish. A minimum of 19mm thick insulation is recommended for 32mm external pipes.
 - The use of a drain cover (such as those to prevent leaf blockage) may offer further protection from wind chill.

Additional protection for transition through a wall.

The external pipework can be insulated to help prevent freezing during prolonged cold periods.

- Where insulation is required, the entire run of external pipework [5] should be insulated with a recess in the external face allowing better insulation protection coverage [4] as it transitions to the outside of the building.
- The hole through the wall must be sealed to the building fabric on the internal [1] and external [3] face using a suitable building material, (use a 40mm sleeve [2] to pass the condensate pipework through and then seal the internal and external faces).

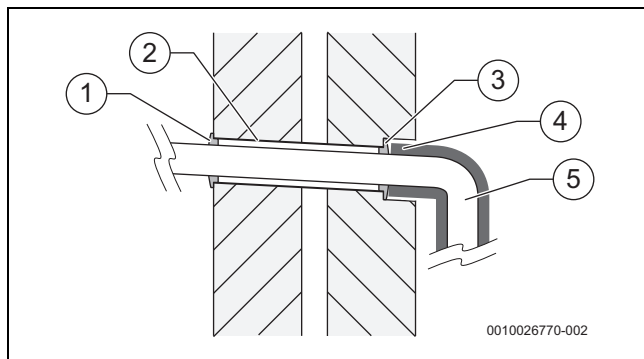

Fig. 38 Additional protection for transition through a wall

- [1] Internal face sealed (32mm pipe sealed to sleeve)
- [2] 40mm sleeve
- [3] External face sealed (32mm pipe sealed to sleeve)
- [4] Insulation recessed into the wall
- [5] Condensate discharge pipe



Good Practice

- ▶ The following guidance indicates the good practices that must be maintained for the Installation and Maintenance of a product.

Rain water down pipe with external air break

→ Figure 39

- Refer to following example to dispose of condensate to a rain water down pipe.
- An air break or rain water hopper must be utilised, between the appliance condensate outlet and the drainpipe, outside the property, to avoid flooding of the appliance should the downpipe become obstructed.

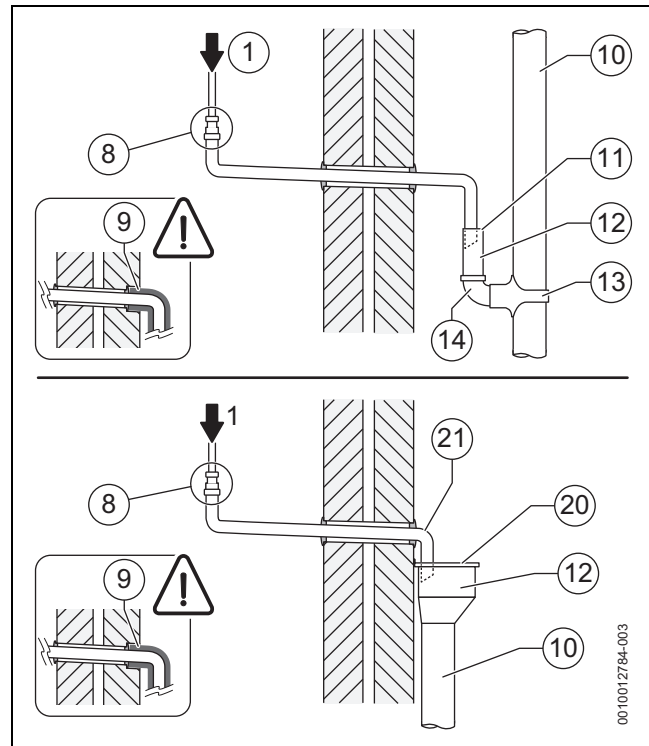

Fig. 39 Disposal into rain water down pipe

- [1] Condensate discharge from appliance
- [8] Pipework transition
- [9] Additional protection for transition through a wall. (→ page 30)
- [10] External rain water pipe to foul water
- [11] External air break
- [12] Air gap
- [13] Strap-on fitting
- [14] 43mm 90° male/female bend
- [20] Rain water hopper
- [21] Increase pipe size

Open drain or gully with external air break

→ Figure 40

Where the pipe terminates over an open drain or gully and there is a risk of ground flooding, then the additional requirement below is recommended:

- An air break should be installed in the external pipework as shown to avoid an airlock during ground flooding/adverse weather conditions which could prevent the condensate from discharging.

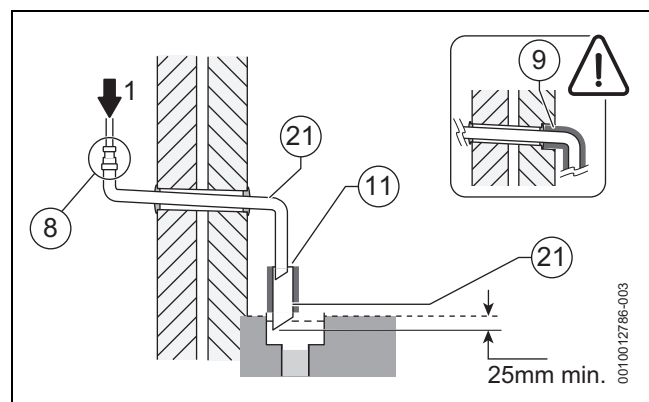

Fig. 40 Disposal to open drain or gully with air break

- [1] Condensate discharge from appliance
- [8] Pipework transition
- [9] Additional protection for transition through a wall. (→ page 30)
- [11] External air break
- [21] Increase pipe size

Condensate soak away considerations

Before deciding to use a purpose-made soak away the history of the locality and the ability of the surrounding area to disperse the condensate should be taken into account, e.g. areas prone to flooding and ground with a high clay content can result in poor drainage with an increased risk of water logging or freezing causing the condensate pipe to become obstructed by water or ice and the boiler to shut down,

Although it is possible to increase the size of the soak away and the area with limestone chippings in clay soil areas, if the clay content is high and prevents effective dispersal of the condensate then a soak away may not be a suitable means of condensate disposal and an alternative method should be used.

Condensate soak away with external air break

→ Figure 41

- Refer to following example to dispose of condensate to a soak away.
- The condensate soak away must be sited at least 500mm away from building footings.
- The condensate drainage pipe may be run above or below the ground to the soak away. The following example shows drainage pipe run above ground.
- The soak away must use a minimum of a 100mm Ø plastic tube with two rows of three 12mm holes on 25mm centres and 50mm from the bottom of the tube. The holes must face away from the house.
- The tube must be surrounded by at least 100mm of limestone chippings to a depth of 400mm.
- An air break must be installed in the external pipework as shown to avoid an airlock during ground flooding/adverse weather conditions which could prevent the condensate from discharging.



Minimum hole size for the condensate soak away must be 400mm deep by Ø 300mm.

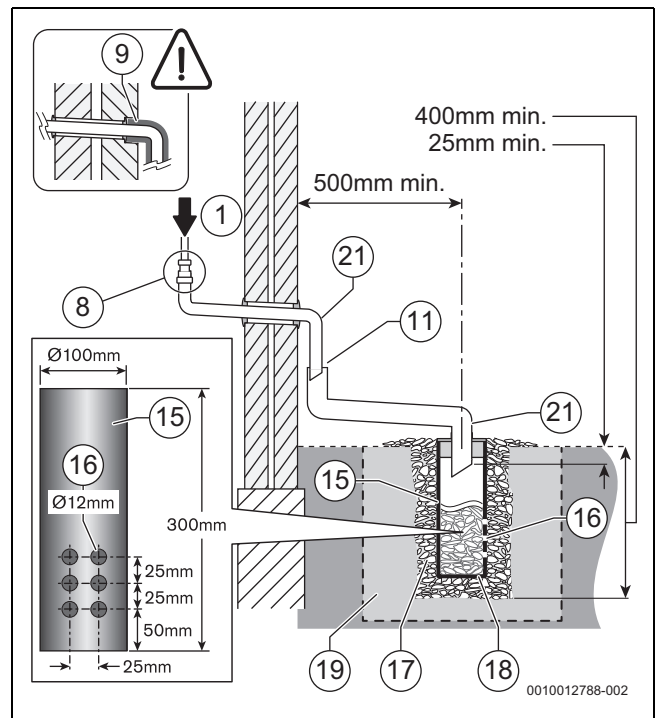

Fig. 41 Disposal to soak-away

- [1] Condensate discharge from appliance
- [8] Pipework transition
- [9] Additional protection for transition through a wall. (→ page 30)
- [11] External air break
- [15] 100mm minimum Ø plastic pipe
- [16] Drainage holes
- [17] Limestone chippings
- [18] Bottom of sealed tube
- [19] Increase size of soak away size and the area with limestone chippings if in clay soil area. Not recommended for high clay soil areas.
- [21] Increase pipe size



Minimum Standard

- The following guidance indicates the minimum standards that must be maintained for the Installation and Maintenance of a product.

Appliances with large capacity condensate trap or CondenseSure accessory or have trace heating fitted.

The need to insulate the pipework through the wall is not normally required for appliances with a large capacity condensate trap or CondenseSure/trace heating fitted for external runs under three metres. These pipes should be sleeved though the wall and the insulation recessed when used.

Cavity wall considerations:

- Whilst insulating the pipe through a typical external wall is unlikely to be required for added protection against freezing in most circumstances, it might be a consideration where the property is located in particularly cold, exposed areas, has an uninsulated cavity or perhaps an unusual construction where there is a larger than normal cavity between the inner and outer wall.

Trace heating fitted:

- Check with trace heating manufactures instructions for additional requirements.

Large capacity condensate trap or CondenseSure fitted to the appliance:

- External pipework exceeding three metres in length or an installation with increased risk of freezing due to environmental factors:
 - Additional protection of insulating the entire run of the condensate pipework [2] should be carried out. The pipe should be insulated externally using suitable waterproof and weather resistant insulation.
 - The hole through the wall must be sealed to the building fabric on the internal [1] and external [3] face using a suitable building material.

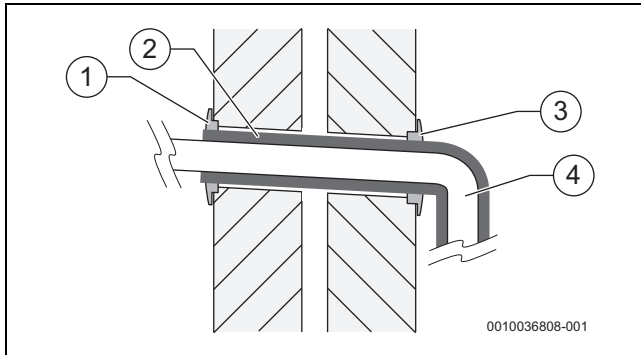

Fig. 42 Through the wall lagging example

- [1] Internal face sealed
- [2] Insulation
- [3] External face sealed
- [4] Condensate discharge pipe

4.6 Pressure relief discharge

4.6.1 Pressure relief pipework



CAUTION

Scalding risk from hot water or steam!

- ▶ The pressure relief valve (PRV) is an appliance safety device and may discharge hot water or steam when activated.
- ▶ The outlet pipe should be sited in such a way that it does not cause a hazard or an obstruction when discharging, for example above a window, entrance door or other public access way.
- ▶ The point of termination should provide a visual indicator in case the PRV discharges.

- The pressure relief discharge pipe [1 or 3] should be run in pipe which has a diameter of at least 15mm, that is made of copper or a material that will withstand PRV discharge temperatures and pressures, and which complies with BS 5254 or BS EN 1451.
- Plastic pipework must be properly supported with a maximum of 300mm between supports to prevent sagging.
- The PRV discharge pipe must run continuously downwards away from the appliance to a safe point of discharge.
- The pressure relief should discharge away from any electrical or other hazard, preferably to an external drain or soak-away.
- The pipe [1 or 3] should be finished with a partial bend, to face the external wall (as shown) to ensure safe discharge of hot water.
- In all normal circumstances a PRV discharge pipe installation as described above sufficiently meets all but the most exceptional circumstances.
 - Where the PRV discharge pipe could be susceptible to damage, vandalism, freezing etc that could cause either a blockage or restriction in the ability to discharge safely then a tundish should be considered. The tundish should be sited in a position where damage to the property or injury to occupants cannot occur from any spillage or discharge.

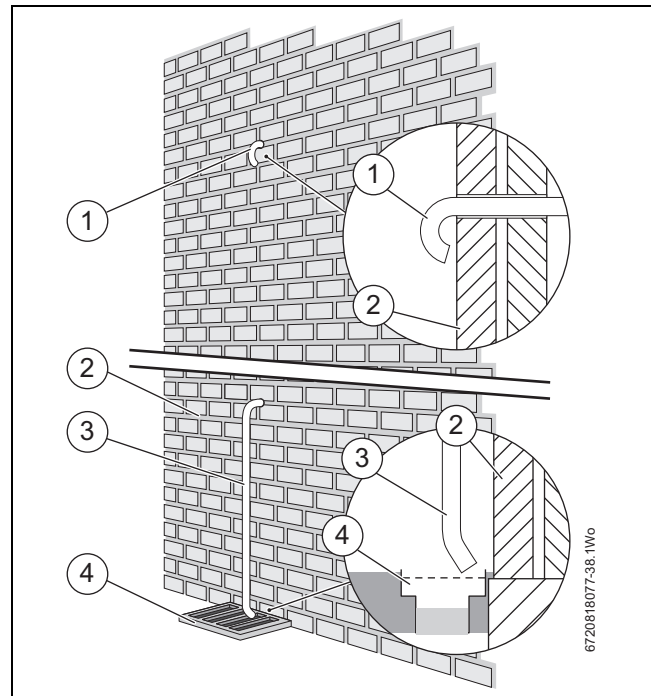

Fig. 43 Pressure relief pipework

- [1] Discharge pipe (turned back onto external wall example)
- [2] Outside wall
- [3] Discharge pipe (into drain or gully example)
- [4] External drain

4.6.2 Alternative PRV connections - Combined PRV/condensate

The PRV or a combined PRV/condensate discharge can be connected into a suitable internal waste system, the installer must ensure that all the pipework, including the waste pipe, is capable of withstanding PRV temperatures and pressures.

Connection to a waste water pipe is possible by using either:

- A shielded tundish with non-return valve used to discharge upstream of a trap (there must not be a trap directly in the PRV discharge pipe without a tundish).
- A PRV can discharge directly into a suitable waste pipe downstream of a trap. Connections must be on top of the pipe to ensure they do not block. A Hotun (or similar) can be fitted for visual indication if desired but is not necessary.

The guidance of BS 6798 sections 6.3.5 and 6.4.3.2a must be followed.



For installations where it is not possible to run the PRV discharge pipe continuously downwards away from the appliance, the remote PRV kit can be used to remove the PRV from the appliance and relocate it to a higher position.

4.7 Cleaning primary systems

NOTICE

Risk of damage to system or appliance!

Debris from the system can damage the appliance and reduce efficiency. Failure to comply with the guidelines for the use of water treatment with the appliance will invalidate the appliance guarantee and contravene the Building Regulations.

- ▶ It is a requirement of the Building Services Compliance Guide which is a second tier document to the Building Regulations to flush and inhibit the primary water system in accordance with BS 7593.
- ▶ The Building Services Compliance Guide recommends that a primary water cleanser is fitted to the system.
- ▶ Worcester Bosch recommend fitting a filter that will help remove both magnetite and non-magnetic debris. Worcester offers various filters that help remove both magnetite and non-magnetic debris; see accessories list for available options.

NOTICE

Risk of damage to system or appliance!

- ▶ Salt based, artificially softened water that adjusts the pH value MUST NOT be used to fill the system.
- ▶ Alternatively there are water softening/treatment products that do not adjust or alter the pH levels of the water. With these products it may not be necessary to provide an untreated water by-pass to the primary water filling point of the heat system

NOTICE

Sealing agents

Normally the addition of sealing agents to the system water is not permitted as this can cause problems with deposits left in the heat exchanger.

- ▶ Heating systems may lose small amounts of water over time. In cases where all attempts to find a system micro leak have failed, Worcester, Bosch Group supports the use of Fernox F4 leak sealer.

Before cleaning the system:

- ▶ Ensure that the system and pipework is in good working order.
- ▶ **Where possible keep the existing appliance/circulating pump in place when flushing the system before installing the new appliance. Alternatively use an after market power flushing system or similar to remove magnetite and other debris from the central heating system.**
 - Even new central heating systems contain contaminants that need to be removed before treating the system with inhibitor/anti-freeze.
 - When an appliance is installed onto a new system then it is possible to use the appliance whilst cleaning the system. A system filter must be fitted to the return to reduce the risk of contaminants entering the appliance.
- ▶ **Follow the guidance of BS7593.**

Inhibitor

Add a suitable inhibitor or combined inhibitor/anti-freeze, if the system is exposed to freezing conditions, to the heating system in accordance with the DWTA code of practice and manufacturer's guidelines.

Products approved to the BuildCert standard are deemed as compatible with the components and equipment within the appliance and system.

Water treatment products

Suitable water treatment products can be obtained from the following manufacturers:

ADEY	01242 546700 www.adey.com
FERNOX	0330 100 7750 www.fernox.com
SENTINEL	01928 704330 www.sentinelprotects.com/uk

Table 18

4.7.1 Flushing the system

Flushing the system using existing appliance/circulating pump or new appliance.



Existing appliances/circulation pumps

- ▶ An existing appliance/circulating pump should be used to flush the system before the new appliance is installed.



New appliances

- ▶ A new appliance must only be used to assist the cleaning of a **newly installed** system.
 - ▶ Fill the system with cold water and check for leaks.
 - ▶ Open all drain cocks and drain the system.
 - ▶ Close drain cocks and add a suitable flushing agent **compatible with aluminium** at the correct strength for the system conditions in accordance with the manufacturer's instructions.
 - ▶ Mark the position of the lockshield valves and open them fully.
 - ▶ Fully open all TRVs.
 - ▶ Circulate the flushing agent before the appliance is fired up.
 - ▶ Run the appliance/system at normal operating temperature as directed by the manufacturer of the flushing agent.
 - ▶ Drain and thoroughly flush the system to remove the flushing agent and debris. Do not drain the system through the PRV of new appliances.
 - ▶ It may be necessary to use a power flushing machine to aid the cleansing procedure in some circumstances.
 - ▶ Close the drain cocks and manual air vents.

For existing appliance/circulating pump actions.

- ▶ Add a suitable inhibitor to the system in accordance with the manufacturer's instructions.
- ▶ Fill the system to between 0.8 and 1.7 bar via a WRAS approved filling loop.
- ▶ Vent any air from the appliance and system.

For new appliance.

- ▶ Once the new appliance has been installed follow the guidance in Filling the appliance and adding inhibitor section.

5 Installation

NOTICE

Risk of damage to appliance or accessories.

- ▶ All the previous pre-installation sections must be read and requirements met before starting the appliance or flue installations.

CAUTION

Risk of injury through incorrect lifting and carrying!

- ▶ Only lift a manageable weight, or ask for help.
- ▶ Bend the knees and keep the back straight with feet apart, when lifting or putting down heavy objects.
- ▶ DO NOT lift and twist at the same time.
- ▶ Lift and carry object close to the body.



Appliance on site

- ▶ Check contents of delivery are undamaged.
- ▶ Remove the appliance from its packaging check the contents against the scope of delivery.
- ▶ Once the appliance is unpacked the installation can commence.

Important handling instructions

- It is advised that two people are used to carry the carton from the vehicle to the point of delivery.
- Once the carton is in the property, the outer carton is removed first. Care should be taken when releasing the straps. If a sharp implement is used make sure the outer carton is not pierced and that the implement is used in such a way so that it may not cause personal injury.
- All sharp objects must be covered or the blade retracted after use and put away in a safe place. Care should be taken when lifting the appliance from the base and the proper technique for safe lifting of any heavy object should be strictly observed.



The appliance packaging and base tray are designed so that the appliance can be tilted backwards onto the outer carton. The carton then becomes a protective mat.

Now remove the front casing and set safely aside. This is to protect the casing from damage during installation.



The front casing is secured with two screws which are critical to maintain the case seal and to prevent unauthorised removal (electrical safety).

- ▶ Always secure the casing with these screws.

Removing the front casing during unpacking.

- ▶ Loosen the two screws [1] and lift the bottom of the casing clear of the screws.

- ▶ Lift off the casing.

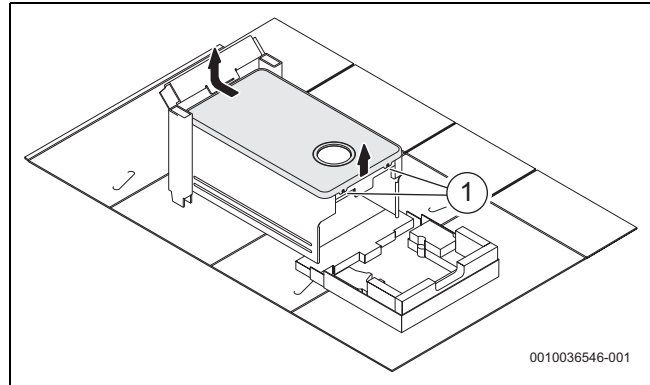

Fig. 44 Removing the front casing

Additional requirements for roof space installations

- The unpacked appliance can now be moved into the loft space
- Two sets of steps should be used.
- Two people should share the lifting of the appliance up to the loft hatch, tilt and slid on its back into the loft space.
- Ensure that the roof space has permanent fixed lighting, a permanent fixed retractable ladder and a fixed floor area, from the hatch to the appliance installation point. This will allow access for installation, normal use and servicing.



Before installing the appliance, ensure that the system has been cleaned.

5.1 Position the appliance

WARNING

- ▶ Ensure the mains gas supply is isolated before starting any work and follow all relevant safety precautions.



Appliance positioning

- ▶ Ensure the appliance is mounted onto a flat, fixed rigid surface capable of supporting the appliance weight.
- ▶ Ensure all aspects of the installation are considered when positioning the appliance, flue run and discharge, condensate disposal, PRV discharge etc.

WARNING

Damage to property!

Damage caused by drilling into pipes, electrical cables, damp proof course or other hazards.

- ▶ Before drilling ensure that there are no obstructions or other hazards.

NOTICE

Damage to appliance!

Residue, metal shavings, and contaminants in the system pipework can damage the appliance.

- ▶ Flush the system pipework thoroughly to remove all residue.
- ▶ Follow the instructions with respect to cleaning primary systems.

Running pipes behind the appliance.

- Do not cross pipes over one another.
- Consider the routing of the flue pipe prior to fixing the position of additional pipework.
- Only follow the routing defined on the wall mounting template.

5.1.1 Mounting frame fixing

i Existing wall fixings positions may be used if the old boiler was an i System.

simple switch WALL MOUNTING SYSTEM

- ▶ The existing wall fixings can be used only if deemed suitable.
- ▶ In all cases, the 2 bottom fixings will align with i System wall frames. In SimpleSwitch cases it is recommended to fix the bottom screws and use the wall frame itself as the template for top fixings.

i Alternate position for PRV pipe is available for SimpleSwitch.

simple switch WALL MOUNTING SYSTEM

- ▶ PRV pre-plumbing connector (elbow) can be rotated to the right (approx. 45°) to line up with pre-existing PRV installation pipework of i System.

i If replacing an i System then a SimpleSwitch flue adaptor (7 733 601 245) is available for vertical flues or horizontal side flue outlets. This accessory enables the use of the existing flue hole. This is only relevant for 60/100mm flues.

i Wall mounting template

- ▶ The wall mounting template has been sized to allow for the minimum clearances around the appliance, (→ section 4.3.3 "Appliance clearances").

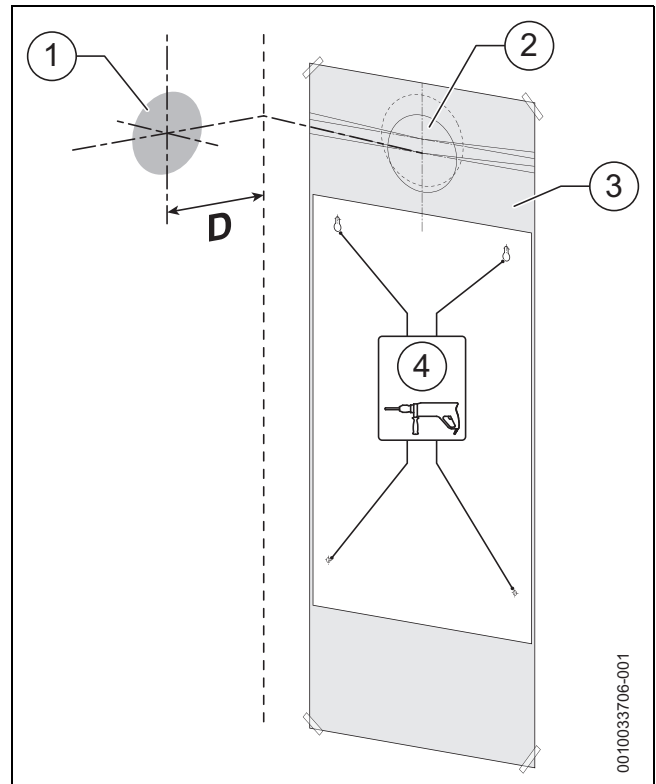

Fig. 45 Wall mounting template

- 1 Side exit flue example
- 2 Rear exit flue example
- 3 Wall mounting template
- 4 Primary fixing points
- D 135mm

The appliance wall mounting template shows the relative positions of the flue and the top and bottom fixings of the wall mounting frame.

- ▶ Fix the wall mounting template [3] to the wall in the desired position.
- ▶ Drill the holes [4] through the template for the primary fixing points as indicated on the template.
 - Additional fixing points for the appliance will be indicated on the wall mounting template.
 - The bottom fixing holes **must** be used as the plumbing manifold is not robust enough to support the appliance.

Flue outlet position.

The appliance wall mounting template has the flue centre lines for the following flue systems:

- 60/100mm
- 80/125mm

i Flue turret adaptor

- ▶ The flue turret adaptor has an in-built 3° angle giving the flue assembly the rise from the appliance to ensure the condensate flows back to the appliance.

Rear flue outlet [2].

- ▶ Mark centre line of flue to be used; the external diameter of the hole can also be marked if required.
- ▶ If extensions are to be added then the complete flue must rise at an angle of 3° from the appliance.

Side flue outlet [1].

- ▶ Mark from the centre line of the wall mounting template to the wall which the flue will pass through.
- ▶ Allow for a rise of 52mm per metre length of flue, to give a 3° angle.

Example hole size.

- If a 60/100mm diameter flue is to be used, a 125mm diameter hole is required.
- If using the weather sealing collar by pushing it through from inside the property, then a 150mm diameter hole is required to accommodate this.

Flue outlet position marked and ready to drill hole.

- ▶ Drill hole using a core drill or similar.
- ▶ Clear any debris from the site.

Appliance fixings and flue outlet drilled and ready.

- ▶ Remove the wall mounting template.

5.2 Appliance connections

WARNING

Appliance - gas connection

- ▶ Ensure the mains gas supply is isolated before starting any work and follow all relevant safety precautions.

NOTICE

Appliance - hydraulic connections

- ▶ Ensure all water pipework, to be connected, are isolated/drained and follow all relevant safety precautions.
- ▶ Be careful of plastic components when using a naked flame on pipework.

i Surplus water may be present inside the appliance due to factory testing.

i External condensate pipework or internal pipe runs in unheated areas such as lofts, basements and garages exposed to prolonged cold temperatures should be protected (→ chapter 4.5).

Plumbing manifold

i Further guidance on pipe routing can be found printed on the appliance template (supplied with the appliance).

i For further ease of fitting, an optional Vertical Pre-piping Assembly kit (7 733 601 250) is available, comprising of pre-formed copper CH and DHW pipes.

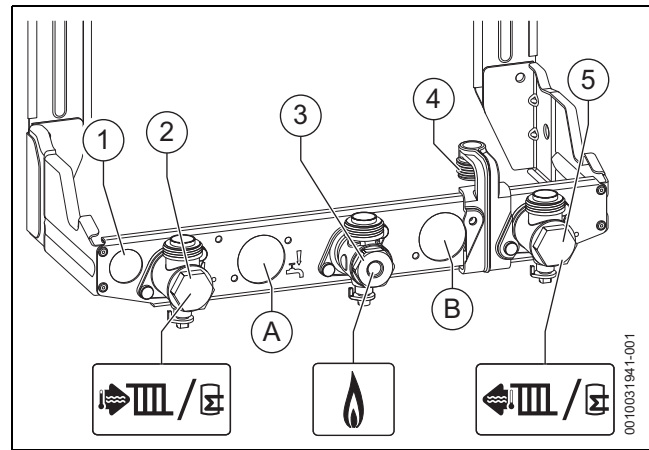

Fig. 46 Connections on the gas and water side

- [1] Position for condensate pipe.
- [2] Central Heating/ Cylinder Flow.
- [3] Gas connection.
- [4] PRV pre-plumbing connection locator bracket.
- [5] Central Heating/ Cylinder Return.
- [A] Position for optional integral diverter valve kit, Cylinder Flow connection.
- [B] Position for optional integral diverter valve kit, Cylinder Return connection.

Condensate discharge connection preparation

Pre-fit the plastic condensate drain pipe through the wall frame as shown in figure 47.

- ▶ Secure the pipe to the wall at the last joint.
- ▶ Ensure the pipe protrudes through the wall frame by 25mm [D].
- ▶ If exiting through the wall, to run externally, the pipe must have a 3° fall and be increased to a 32mm insulated pipe.

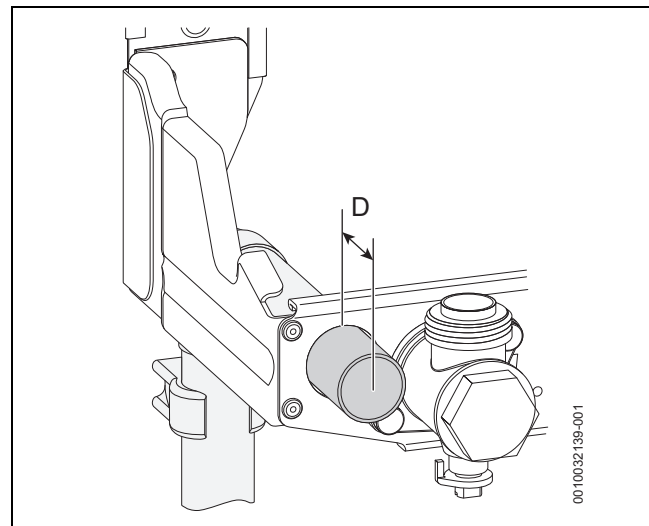

Fig. 47 Condensate drain pipework detail

- [D] Protrusion dimension - 25mm

PRV pre-plumbing connection preparation

i The PRV elbow has been designed to also be SimpleSwitch to the i Junior and Si boilers. The PRV pre-plumbing connector can be routed to the right (approx. 45°) to line up with pre-existing PRV pipework from i Junior and Si boilers.

- ▶ Connect PRV pre-plumbing connector to pre-existing PRV installation pipework
- ▶ Fit the PRV pre-plumbing connector [2] to the PRV locator bracket [1] as shown in the figure 48.
 - The elbow (PRV pre-plumbing connector) [2] is supplied with the appliance.
 Once the wall frame has been mounted the PRV discharge pipe can be fitted.
- ▶ Connect the PRV discharge pipe [3] to the PRV pre-plumbing connector [2].
- ▶ The discharge pipe [3] can be routed as required.

i The PRV locator bracket [1].

- ▶ This bracket must be removed before the appliance is hung on the wall frame.

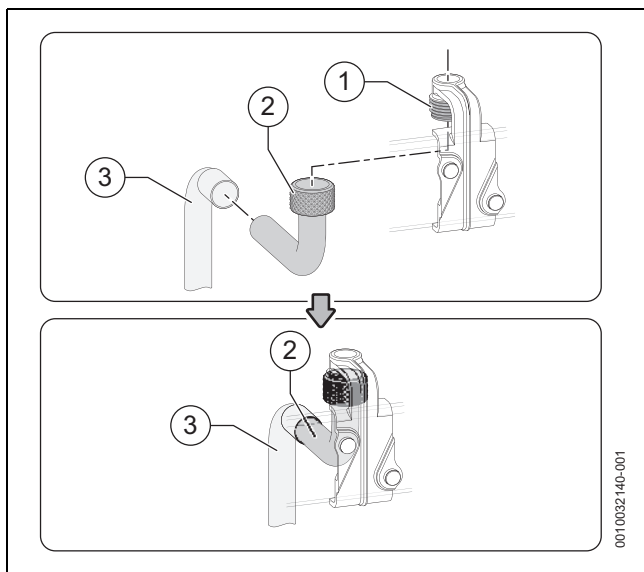

Fig. 48 PRV connection preparation

5.3 Hanging the appliance

NOTICE

Transport protection covers

- ▶ Remove any internal transport packaging and protection covers from the appliance where applicable.

Before hanging the appliance

- ▶ Install any accessories to the mounting frame before continuing.
- ▶ Ensure the sealing washers are fitted to the appropriate service valves before installing the appliance onto the mounting frame.
- ▶ Ensure that the control panel is in its closed position before lifting the appliance.

Preparing the service valves

i The bonded washer supplied is for the Gas connection only.

- ▶ Fit the sealing washers to the service valves before hanging the appliance.

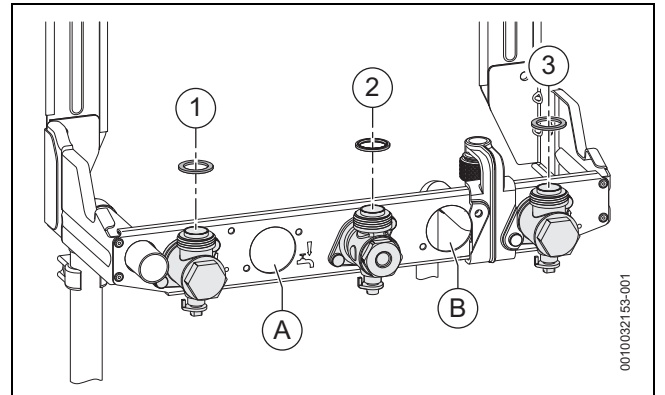

Fig. 49 Fitting the sealing washers

- [1] Central Heating Flow (22mm)
- [2] Gas Inlet (22mm bonded washer)
- [3] Central Heating Return (22mm)
- [A] Position for optional integral diverter valve kit, Cylinder Flow connection (15mm).
- [B] Position for optional integral diverter valve kit, Cylinder Return connection (15mm).

Preparing the wall frame

- ▶ Remove the temporary PRV pre-plumbing connector [3]:
 - Unscrew the PRV outlet pipe [2] from the pre-plumbing connector [3].
 - Remove the screw [4] holding the pre-plumbing connector [3] in place.
 - Remove the pre-plumbing connector [3], and discard.
 - Replace the screw [4] removed earlier and tighten firmly.



Removing the pre-plumbing connector [3] when the optional integral diverter valve kit fitted.

- ▶ There will be an additional screw for retaining the cylinder return connection service valve to be fitted.

- ▶ Fit the sealing washer for the PRV before hanging the appliance.
- ▶ The appliance is mounted on the wall frame utilising the central mounting point [1], at the top of the wall frame.

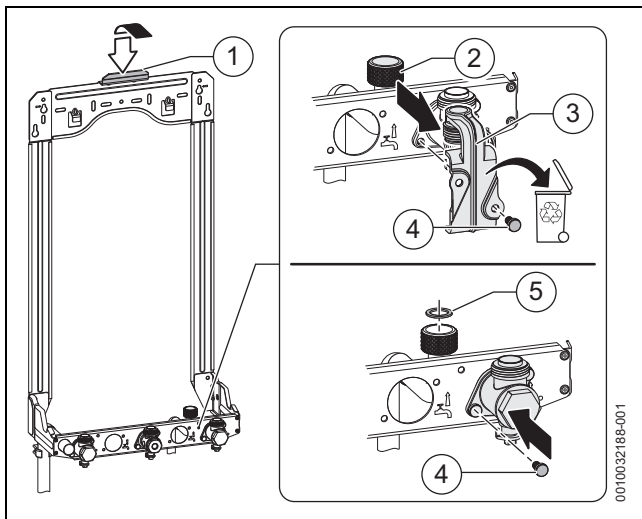

Fig. 50 Wall frame preparation

Hanging the appliance



WARNING

Bonded washer (plumbing manifold gas connection)

- ▶ The bonded washer must be used on the gas pipe isolating valve connection.
- ▶ Ensure the sealing washers are correctly seated on the appropriate service connectors before installing the appliance.

Refer to figure 51.

- ▶ Hang the appliance on to the wall mounting frame utilising the central mounting point, at the top of the wall frame.

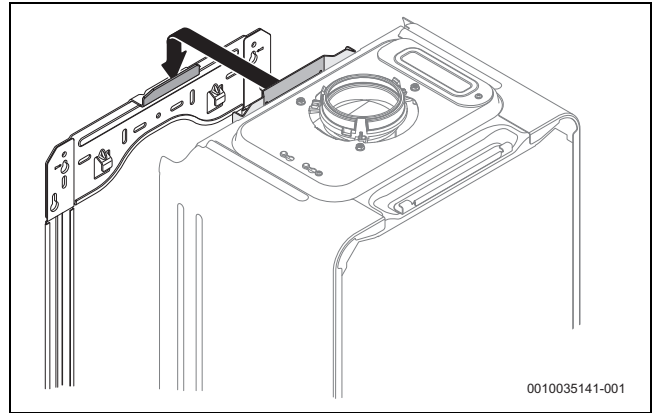

Fig. 51 Hanging the appliance

- ▶ Connect the PRV discharge pipe on the hydraulic unit onto the PRV outlet pipework, and tighten firmly.
- ▶ Tighten the gas and water connections firmly.

Fitting the siphon



WARNING

Danger to life due to poisoning!

If the condensate trap is not filled, poisonous flue gas can escape.

- ▶ Fill the condensate trap with approximately 250 ml water before fitting.

Refer to figure 52.

- ▶ Remove the transport piece fitted to the appliance connection point.
- ▶ Remove the seal protection cover from the siphon itself.
- ▶ Fit the discharge elbow to the 25mm condensate pipework protrusion on the wall frame.
- ▶ Fill the condensate siphon with approx. 250 ml water.
- ▶ Fit the condensate siphon [1]. Ensure the alignment arrow on the locking arm is in the locked position (refer to the siphon label for guidance).
 - Ensure the condensate siphon is secured correctly.
- ▶ Fit the discharge elbow [2] onto the outlet, ensuring the locating arrows are aligned.

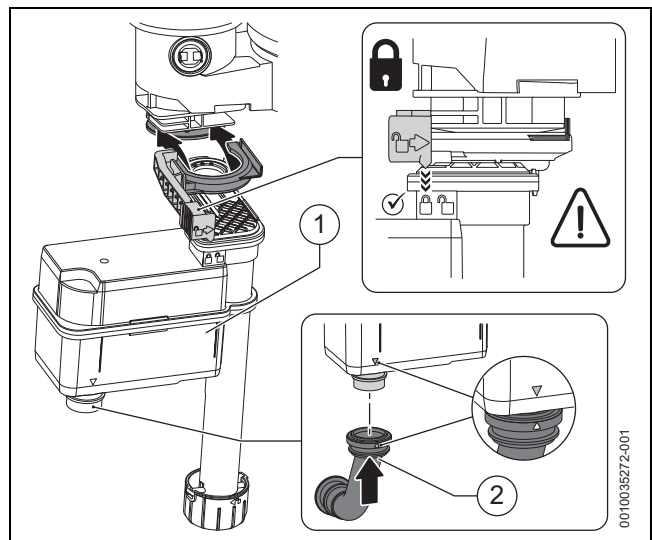

Fig. 52 Siphon fitting

5.4 Flue turret/adaptor installation

NOTICE

Flue installation

- ▶ Refer to the Flue Kit Installation instructions provided with your flue kit to correctly install the flue with this appliance.
- ▶ Do not exceed the maximum straight length for a horizontal or vertical flue or a 60mm plume management system (if used) as stated in chapter 4.4



Telescopic flue

- ▶ Cutting the flue to an exact measurement is not required as the telescopic flue terminal can allow for some adjustment.



Apply silicone lubricant to sealing surfaces, to ease assembly of flue components. Refer to the manual supplied with the flue kit for complete installation instructions.

- ▶ For plume management and effective flue lengths (→ chapter 4.4).

Additional notes and reminders:

- Ensure that all cut lengths are square and free from burrs and cutting/filing debris.
- Ensure that the flue and seals are not damaged.
- The flue is sealed when assembled correctly, ensure the components are pushed fully home and secured.
- The flue rises from the appliance at an angle of 3° or 52mm per metre length.
- Support the flue at each flue extension joint and at each change of direction, use suitable brackets and fittings:
 - Flue bracket 100mm, part number: 7 716 191 177.
 - Flue brackets 100mm x 6, part number: 7 716 191 178.
 - Flue bracket 125mm, part number: 7 716 191 179.
- Ensure the external wall seal is fitted and properly located in the groove provided on the terminal. This seal must be installed in the groove unless the flue is extended beyond a gutter or balcony as shown in the installation instructions.

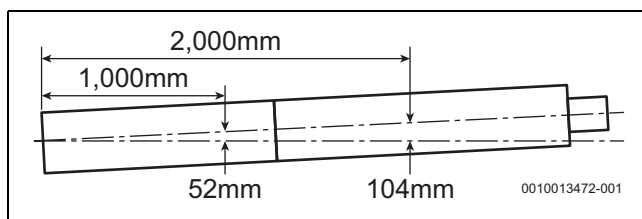

Fig. 53 Slope for condensate disposal

Refer to figure 54.

- ▶ Remove the three inner flue tube retaining screws [1].
 - The inner tube will be held in place in the appliance.
- ▶ Check the appliance flue seal [2] is correctly seated and apply silicone grease.

Flue turret [A] fitting

- ▶ Align the flue turret [A] to the appliance flue outlet with flat facing [3] to the rear of the appliance.
 - This should be pushed straight down, on to the appliance.
- ▶ The three inner flue tube retaining screws [1] are re-used to secure the flue turret [A].

Vertical adaptor [B] fitting

- ▶ Align the vertical adaptor [B] to the appliance flue outlet with flat facing [3] to the rear of the appliance.
 - This should be pushed straight down, on to the appliance.
- ▶ The three replacement retaining screws [4] supplied with the adaptor kit are used to secure the vertical adaptor [B].

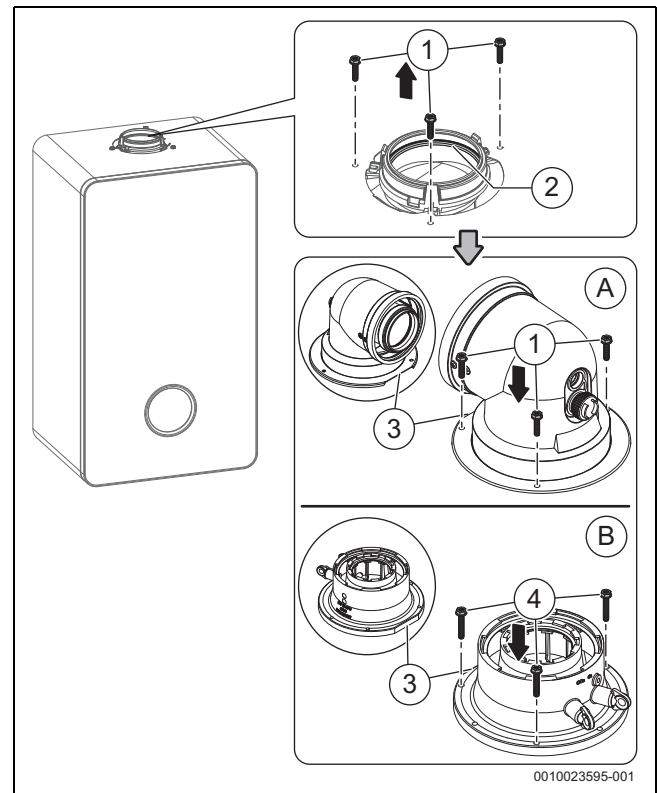

Fig. 54 Flue turret/adaptor connection

5.5 Electrical connection

DANGER

Risk of electric shock!

- ▶ Isolate electrical components from the power supply (230 V AC) (fuse, circuit breaker) and secure against unintentional re-connection before carrying out any work.
Information on safe isolation can be found in the Health and Safety Executive guidance HSG85.
- ▶ Check for zero potential before proceeding with work, using test equipment approved to GS38 to confirm that the electricity supply is disconnected.

i

Electrical considerations:

- ▶ All electrical work must be carried out by a competent and authorised person.
- ▶ All work must comply with the current IET Wiring Regulations.
- ▶ The isolator shall be situated next to the appliance for new systems and, where practicable, replacement appliances.
- ▶ The mains electrical supply to the appliance must be through a fused double pole isolator.
- ▶ The isolator must have contact separation of 3mm minimum between poles. Any system connected to the appliance must not have a separate electrical supply.
- ▶ Any additional components that are connected to the appliance that require 230 Volts must be connected to the same supply as the appliance.
- ▶ The correct type of RCD must be employed where additional protection is required that is suitable for a low energy DC modulating pump according to IET wiring regulations.
- ▶ External fuse 3 Amps.
- ▶ When stripping the wires, ensure copper strands do not fall into the control box.

NOTICE

Risk of damage from hot appliance components.

Hot appliance components can damage electrical cables.

- ▶ Ensure all electrical cables are in the correct cable guides and away from hot appliance components.

i

Cable routing:

- ▶ Route cables over the valve bracket avoiding any hot components.
- ▶ Run power cables separately from signal cables. Interference from power cables can induce spurious faults on signal cables, ensure that there is at least 100mm separation between power and signal cables.
- ▶ Ensure the cables are of sufficient length to allow the control box to be moved to the service position.

If the power cable is of insufficient length and is to be replaced, access the connection terminal (→ Fig. 57)

- ▶ Replace with the following cable type:
 - H05V2V2F x 0.75 mm² (heat resistant PVC, for fixed installation appliances, in accordance with the latest edition of national and local wiring regulations)
 - A spare strain relief is supplied in the hardware pack, if required.
- ▶ Connect the cable so that the protective conductor (earth) is longer than the other wires.

5.5.1 Cable preparations

NOTICE

Damage to control unit!

Small pieces of wire can cause shorts and damage to electronics.

- ▶ When stripping wires always ensure copper strands do not fall into the control box.

Power supply (power cables), example → figure 55

- ▶ Ensure the conductors (C) can reach the appropriate terminal connection and that the protective (earth) conductor is longer than the other wires.
 - Power cables connected to the appliance may have different conductor lengths depending on the termination point.

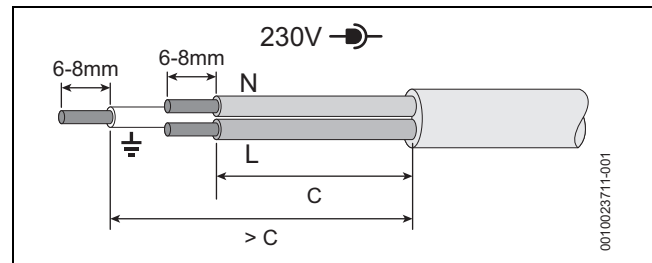

Fig. 55 Power supply (power cables) preparation

Low voltage (signal cables), example → figure 56

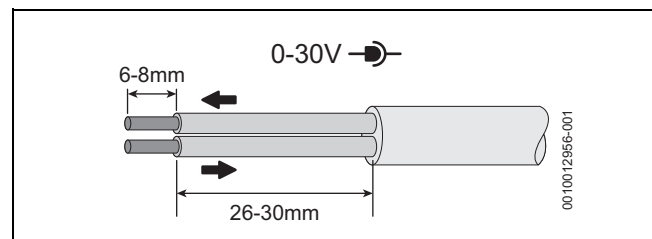

Fig. 56 Low voltage (signal cables) preparation

5.5.2 Installer wiring connections

Access to electrical connections

- ▶ Release side catches and lower control panel into the service position.
- ▶ Loosen the retaining screw [1].
- ▶ Push in the tabs and open the cover.

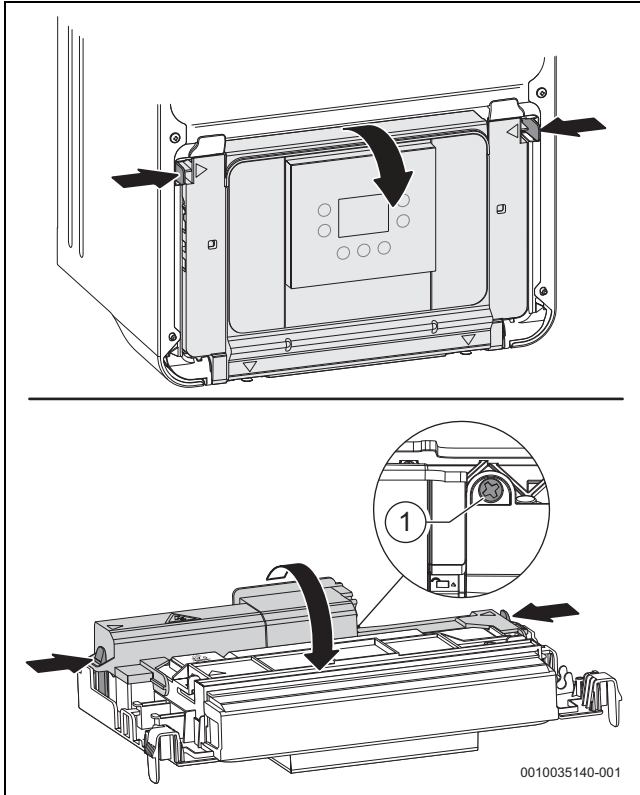

Fig. 57 Opening the cover

Stepped cable grommets

- ▶ For splash-water protection (IP): cut the stepped cable grommets to match the diameter of the cable.

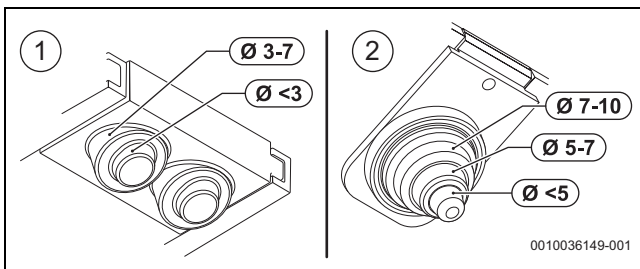

Fig. 58 Adapting the grommets to the cable diameter

- [1] Low voltage (signal cables) grommet
- [2] Power supply (power cables) grommet with strain relief

[1] Low voltage (signal cables)

- ▶ Guide the cable through the grommet.
- ▶ Connect the cable to the terminal strip for external accessories.

[2] Power supply (power cables)

- ▶ Guide the cable through the grommet.
- ▶ Connect the cable to the terminal strip for external accessories and the protective conductor (PE) to the \perp rail.
- ▶ Secure the cable on the strain relief.

Power supply (power cables) terminal strip

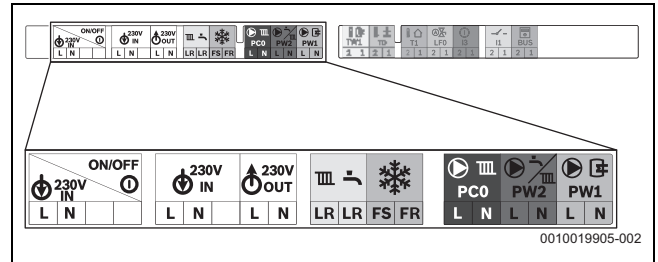

Fig. 59 Power supply (power cables) terminal strip

Earth rail location



Strain relief assembly is removable via a single screw to provide easier access if required.

Connect the protective conductor (earth) cable from the power lead to the earth rail [1].

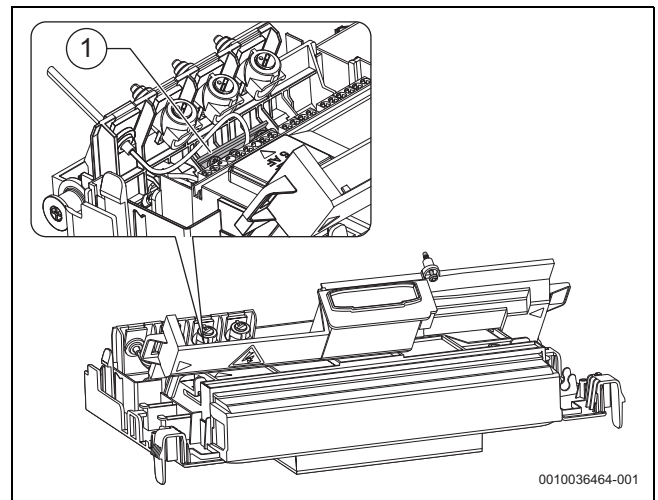

Fig. 60 Earth rail

Power supply (power cables) connections

Symbol	Function
	Power supply (power cable). Pre-wired cable (Live and Neutral).
	No functionality; not used.
	230V mains output to external controls/wiring centre. ▶ If required: connect power supply for external controls.
	Switch live (Live Return) to appliance. • CH demand input. • DHW demand input (active when optional integral diverter valve is fitted).
	External frost thermostat. • FS output (frost thermostat supply). • FR input (frost thermostat return).
	No functionality; not used.
	No functionality; not used.
	No functionality; not used.

Table 19 Power supply (power cables) terminal strip for external accessories

Low voltage (signal cables) terminal strip

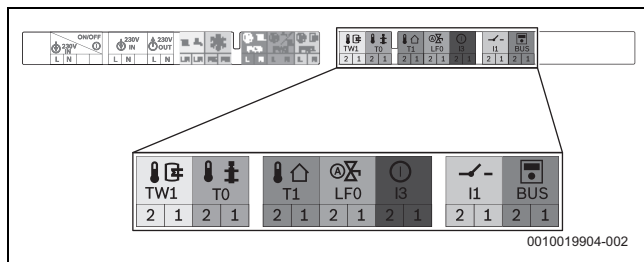

Fig. 61 Low voltage (signal cables) terminal strip

Low voltage (signal cables) connections

Symbol	Function
	No functionality; not used.
	Cylinder temperature sensor. ¹⁾ With optional integral diverter valve fitted ▶ Connect via a 2-core cable.
	Outdoor weather compensation sensor. ²⁾ ▶ Connect via a 2-core cable.
	No functionality; not used.
	No functionality; not used.

Symbol	Function
	No functionality; not used.
	Communication BUS connection for hard-wired Worcester/Bosch EMS controls. ¹⁾ With optional integral diverter valve fitted ▶ Connect via a 2-core cable.

- 1) Only applicable if optional integral diverter valve is fitted
- 2) Diverter valve kit not required for use with Simple weather compensation (accessory 7 716 192 764). Diverter valve kit is required for use with weather compensation in conjunction with Worcester controls.

Table 20 Low voltage (signal cables) terminal strip for external accessories

5.5.3 External controls - Domestic installations



External equipment or Integral diverter valve kit:

- ▶ External diverter valve(s) and all other 230V parts are not supplied with the appliance.
- ▶ There is an optional integral diverter valve kit, this requires fitting a diverter valve, internal pipework, cylinder sensor & connection. See optional diverter valve kit instructions for fitting details. This kit also allows for the Worcester controls options to be used.
- ▶ The power supply to external controls must be taken from the appliance; an alternative power supply must not be used.

Appliance external control connections example

- ▶ The electrical power supply to the external equipment [2] is supplied from 230V OUT - L (Live), N (Neutral) and PE - (earth) terminals.
- ▶ The Switch Live from the wiring centre [3]:
 - Both pre-wired links are removed, the CH & DHW demands are combined and wired to the LR terminal.
 - Control for appliance Pre-heat function, optional. The flow temperature must be set on the central heating control to a level at least 10 °C above the required cylinder temperature set on the cylinder control thermostat.
- ▶ External frost thermostat connections [4]:
 - The Live supply is terminal FS
 - The Switch Live is terminal FR

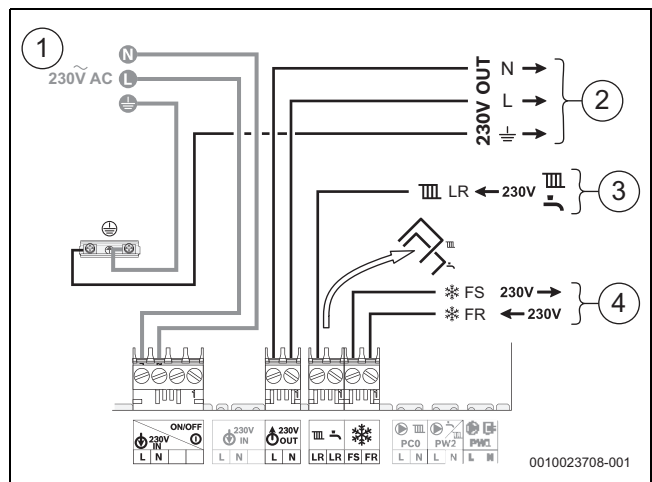

Fig. 62 External controls connections example

- [1] 230V mains supply to the appliance.
- [2] 230V supply from the appliance to the wiring centre.
- [3] CH & DHW Switch Live (Demand) from the external controls.
- [4] External frost protection Live supply and Switch Live (Demand).

6 Commissioning

6.1 Pre-Commissioning checks

DANGER

Risk of electric shock!

- ▶ Isolate electrical components from the power supply (230 V AC) (fuse, circuit breaker) and secure against unintentional re-connection before carrying out any work. Information on safe isolation can be found in the Health and Safety Executive guidance HSG85.
- ▶ Check for zero potential before proceeding with work, using test equipment approved to GS38 to confirm that the electricity supply is disconnected.

Checks before commissioning:

- ▶ Check that the service and water pipes are connected correctly.
- ▶ Check the gas type specified on the identification plate matches that of the gas supply and that the gas supply is properly purged.
- ▶ Check that the appliance is filled with water and under pressure (0.8 to 1.7 bar) and that there are no leaks.
- ▶ Check that the electrical connections of the appliance are correct:
 - Mains electrical supply - 230V, 50Hz
 - Compliant earth connection
 - Correct polarities.
 - External equipment and controls are wired in correctly.
- ▶ Check that the flue is correctly fitted, airtight, free from any obstruction and the connections are secure.
- ▶ Check that the condensate pipework is connected properly and that there are no leaks.

NOTICE

If the appliance is not to be commissioned immediately then, after successfully completing all of the checks and any rectification work:

- ▶ Isolate the electricity supply.
- ▶ Isolate the gas supply.
- ▶ Close the water shut-off valves to the appliance.
- ▶ Label appropriately.

6.2 Water treatment

Primary system flushing (Central Heating)

Ensure that the system has been cleaned:

- Following the guidance of BS 7593:
 - Code of Practice for treatment of water in hot water central heating systems.
- Overview available in Pre-installation, Cleaning primary systems section.

Inhibitor (Central Heating):

Add a suitable inhibitor that is compatible with aluminium (or combined inhibitor/anti-freeze, if the system is exposed to freezing conditions), to the heating system in accordance with the DWTA code of practice and manufacturer's guidelines.



The pH value of the system water must be between 6.5 and 8 or the appliance warranty will be invalidated.



The inhibitor or combined inhibitor/anti-freeze must not cause damage to the materials within the appliance (aluminium, mild steel, stainless steel, copper and brass) and any other materials/components within the system.

- ▶ Record the date when the inhibitor was added to the system on the guarantee card.
- ▶ The concentration level of inhibitor in the system should be checked every 12 months or sooner if system content is lost.

NOTICE

Sealing agents

Normally the addition of sealing agents to the system water is not permitted as this can cause problems with deposits left in the heat exchanger.

- ▶ In cases where all attempts to find a system micro leak have failed, Worcester, Bosch Group supports the use of Fernox F4 leak sealer.

6.2.1 Filling the appliance and adding Inhibitor



Before pressurising the system.

The appliance integral expansion vessel is pre-charged to 0.75 bar (equal to a static head of 7.5m (24.6ft)). A Schrader type valve is fitted to the expansion vessel to allow for pressure adjustment if required.

- ▶ If an extra expansion vessel is fitted to the central heating system, ensure that it is set to the same pressure as the appliance internal expansion vessel, refer to separate instructions supplied with the extra expansion vessel.

Filling the system - Sealed systems

NOTICE

- ▶ Salt based softened water must not be used to fill the central heating system.
- ▶ Check drain cocks and manual air vents are closed and all radiator valves are open. Add a suitable inhibitor or combined inhibitor/anti-freeze, if the system is exposed to freezing conditions, to the heating system water in accordance with the manufacturers instructions.
- ▶ Turn on the water main and open the system valves.
- ▶ Fill the system to between 1 and 1.5 bar via a WRAS approved filling loop.
- ▶ The Automatic Air Vent will release any air trapped in the appliance.
- ▶ Manually vent all radiators, tighten when completed and check the system for any leaks and correct if required.
- ▶ Top up the system pressure if the pressure drops below 1 bar.
- ▶ Isolate and remove filling loop connections to the system.

With the optional diverter kit fitted it is recommended that the mid position of the 3-way valve is used to fill/drain the system.

For initial fill, the boiler automatically selects the mid-position when first powered up.

For future fills to set the 3-way valve to mid position:

- ▶ **Service menu > Settings > Special function > 3-WV mid. pos. > Yes.**



The 3-way valve remains at the middle position for approx. 15 minutes.

- ▶ Ensure that any external zone valves are open, if installed.
- ▶ Fill/drain the system.

6.3 Starting the appliance

NOTICE

Damage to appliance or system!

Running the appliance:

- ▶ Never run the appliance when the appliance/system is empty or partially filled.

6.3.1 Control panel overview

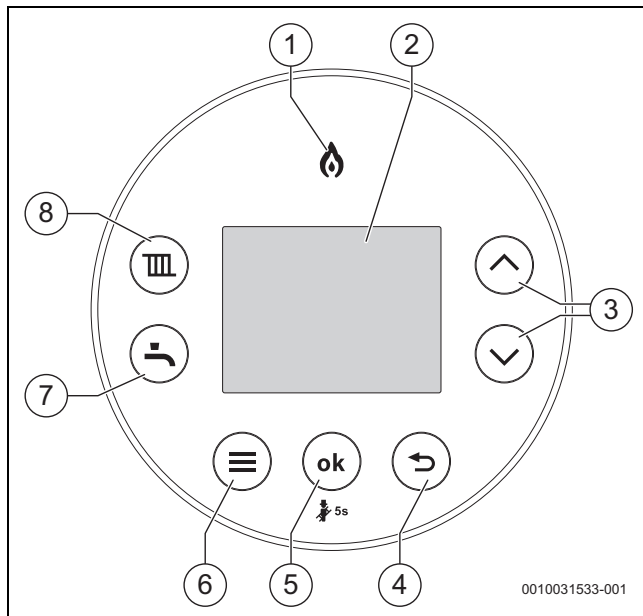

Fig. 63 Overview

- [1] Burner display: Illuminates when the burner is alight.
- [2] Display.
- [3] ▲ and ▼ buttons: To navigate through menus and increase/decrease settings.
- [4] ↶ button: Return/back.
- [5] **ok** button:
 - Confirm/save settings.
 - Chimney sweep button: Press and hold for 5 seconds for chimney sweep mode.
 - Toggle between Eco and preheat (comfort) mode.
- [6] Menu button.
- [7] Hot water button: Hot water mode home screen.
- [8] Heating button: Heating mode home screen.



See the operating instructions for a description of the user menus.

6.3.2 Turning on the appliance

- ▶ Turn on the appliance at the power supply isolator.

6.3.3 Operation



Appliance operation

- ▶ Refer to Operating Instructions for full details on setting the CH flow temperature, DHW temperature set point and the operating settings menu information.

Temperature adjustment overview

Central heating flow temperature adjustment.



With underfloor heating systems observe the maximum permissible flow temperature.

- ▶ Press the  key. The set maximum flow temperature appears.
- ▶ Press the ▲ or ▼ keys to set the desired maximum flow temperature.
- ▶ The setting is saved automatically after two seconds. Then the ✓ symbol is briefly displayed.

Hot water temperature adjustment (only available when an optional integral diverter valve kit is fitted).

- ▶ Press the  key. The set hot water temperature appears.
- ▶ To set the desired hot water temperature, press the ▲ or ▼ keys. The setting will be saved after 5s or after pressing the **ok** key.

6.4 Chimney sweep mode



You have 15 minutes to take your measurements or to make your settings. After this time the appliance returns to normal operation. You can re-enter chimney sweep mode if necessary.

When running in the chimney sweep mode, the appliance will operate both the central heating and the domestic hot water circuits. This is to allow sufficient time for this part of the commissioning procedure. It will be **necessary** to run sufficient hot water through the domestic hot water circuit to ensure that the appliance will not overheat whilst in chimney sweep mode.

In chimney sweep mode the rated output of the appliance can be selected.

- ▶ Press and hold the **ok** key for 5 seconds until **Chimney sweep** is displayed.
- ▶ Confirm you have read and understood the alert message, press **ok**.
- ▶ Set the desired rated output using ▲ or ▼ for 100% and 10% respectively. The value is accepted after 2 seconds and marked with a tick.
- ▶ To exit the chimney sweep mode, press **ok** or ↶.

Adjustment with casing removed in chimney sweep mode

1. Set the chimney sweep mode and start up the appliance at maximum rated output.
2. Set the chimney sweep mode and set the appliance at minimum rated output.

6.4.1 Setting the appliance to maximum



Maximum output mode

- ▶ A hot water outlet must be opened to prevent the appliance from shutting down due to high temperature during testing.
-
- ▶ Press the **ok** key for 5 seconds until **Chimney sweep** is displayed.
 - ▶ Confirm you have read and understood the alert message, press **ok**.
 - The appliance enters chimney sweep mode and automatically enters maximum output.
 - The display shows the maximum percentage power (**100%**) alternating with the flow temperature.
 - The appliance will ramp up to maximum output in approximately 30 to 35 seconds.

6.4.2 Setting the appliance to minimum

Whilst the appliance is already in chimney sweep mode - maximum output.

- ▶ Press the **▼** button to set the appliance to minimum output.
 - The display shows the minimum percentage of the power alternating with the flow temperature.
 - The appliance will take approximately 30 to 35 seconds to ramp down to minimum output.
 - Wait a further 30 seconds to allow the appliance to stabilise at minimum output.

6.4.3 Exiting chimney sweep mode

To exit the chimney sweep mode:

- ▶ Press **ok** or **↶** and the appliance will return to normal operation.
 - If left in the chimney sweep mode the boiler will return to normal operation after 15 minutes.



When exiting chimney sweep mode the pump will continue to run in order to cool the heat exchanger. Boiler status code 208 will be visible during this operation.

6.5 Checking gas inlet pressure

Measuring the inlet pressure

- ▶ Switch off the appliance and close the gas isolator.
- ▶ Unscrew the screw on the test nipple for the gas supply pressure and connect a pressure gauge.

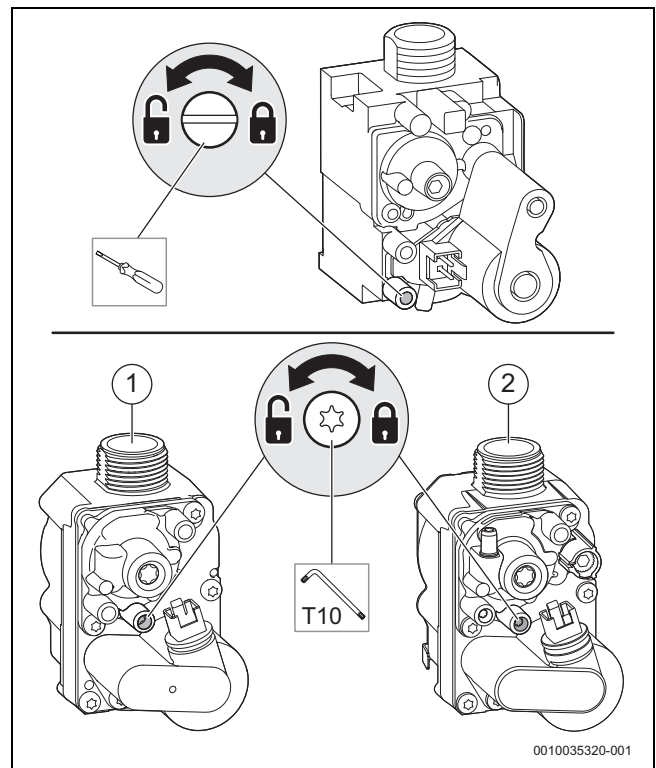

Fig. 64 Checking the gas supply pressure (above: SIT valve, below: Honeywell valves)

- [1] Gas valve - NG
- [2] Gas valve - LPG

- ▶ Open the gas isolator and switch on the appliance.
- ▶ Ensure that there is heat transfer by opening the radiator valves and any zone valves fitted.



Internal diverter valve: When running in maximum output in test mode, and the water temperature is 74°C or less, the appliance will operate both the central heating and DHW circuits with the internal diverter valve in the mid position. It will be necessary to run sufficient water through the DHW circuit to ensure that the appliance will not cycle on low heating demands. This is to allow sufficient time for the setting procedure. When the water temperature reaches 75°C the diverter valve will switch to CH only and will only return to the mid position if the temperature is 65°C or less.

External diverter valve/s: When the internal diverter valve is not fitted, it is recommended to position the external diverter valve in the central heating position.

- ▶ Set the appliance running at maximum output in chimney sweep mode (→ 6.4 "Chimney sweep mode").
- ▶ Check the required gas supply pressure according to following section "Gas pressure within the system".



Commissioning must not take place outside of the permissible pressure range. If necessary:

- ▶ Identify the cause and rectify the fault.
 - ▶ If this is not possible: isolate the device on the gas side and notify the gas supplier.
-
- ▶ Exit the chimney sweep mode.
 - ▶ Switch off the appliance, close the gas isolator, remove the pressure gauge and tighten the screw.
 - ▶ Refit the casing.

Gas pressure within the system



Combi appliances

- ▶ Running a hot water tap does not guarantee the appliance will operate at maximum output throughout the test.

Natural Gas or LPG pressures.

The pressure drop from the meter or at the LPG gas supply to the gas valve inlet test point must not be more than the values stated in table 21. If the pressure drops are greater than shown in table 21, then this would indicate a problem with the pipework or connections within the system.

NOTICE

- ▶ **Do not continue commissioning until the correct gas pressure is achieved with the appliance running at maximum output.**

Gas Type	Meter/LPG supply	Across pipework	Appliance inlet	Across appliance [A]	Gas valve inlet test point [B]
Allowed mbar pressure drop					
NG	19 - 23	1	18 - 22	1.5	16.5 - 20.5
LPG	32 - 45	2.5	29.5 - 42.5	1.5	28 - 41
mbar range					

Table 21 Allowed mbar pressure drop

Gas supply pressure drop

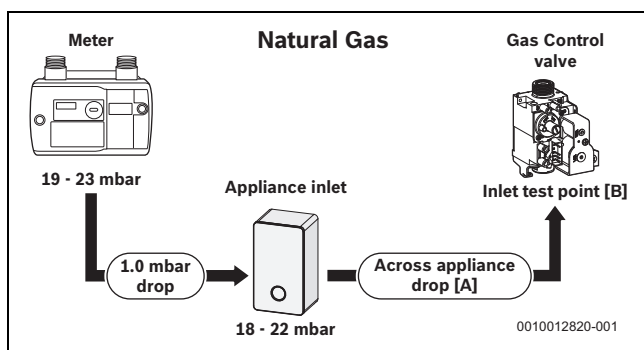

Fig. 65 Natural Gas pressures

- [A] Pressure loss across the appliance
- [B] Pressure reading at inlet test point

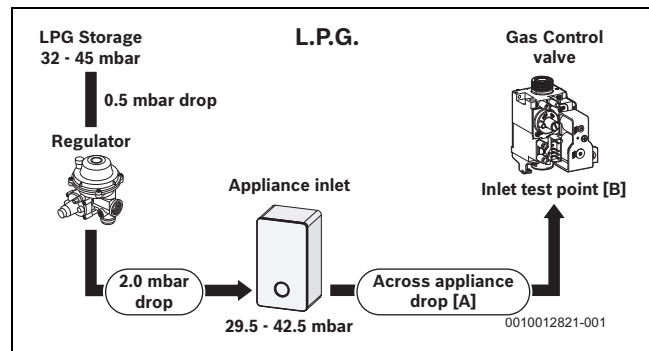

Fig. 66 LPG pressures

- [A] Pressure loss across the appliance
- [B] Pressure reading at inlet test point

6.6 Checking the gas rate



The appliance must be running at maximum output rate when performing the gas rate check, (→ chapter 6.4.1).

- ▶ The gas rate should be measured at the gas meter after the appliance has been operating for **a minimum of 10 minutes** at maximum output.
- ▶ Refer to Technical data section of this manual for the appliance gas rates and CO/CO₂ ratios.
- ▶ Where a gas meter is not available (e.g. LPG) the CO/CO₂ must be checked.
- ▶ Gas rate must be checked with the appliance in service, maximum output test mode.
- ▶ Carry out gas rating as per the latest advice in the Gas Safety (Installation and Use) Regulations.
- ▶ Ensure all other gas appliances are isolated when carrying out the gas rate check on the appliance.
- ▶ Set the chimney sweep mode and start up the appliance at maximum rated output.
 - Ensure that the appliance has stabilised at maximum output.
- ▶ Where a gas meter is not available (e.g. LPG) the CO/CO₂ must be checked to the units shown in the setting of the air/gas ratio.
- ▶ If pressure and gas rate are satisfactory press **ok** or ↶ and the boiler will return to normal operation.
 - If left in the service mode the control will return to normal operation after 15 minutes.
- ▶ Close the gas isolation valve.
- ▶ Remove the manometer.
- ▶ Re-seal the screw in the gas inlet pressure test point.
- ▶ Open the gas isolation valve and ensure there are no gas leaks.

6.7 Checking for gas leaks during operation

- ▶ Use an approved gas sniffer or leak detection fluid to check all connections for possible leaks. Leak detection fluid must be certified as a gas leak testing agent.
- ▶ Do not allow leak detection fluid to come into contact with the electrical components.

6.8 CO and combustion check

The following combustion and flue integrity checks are mandatory and these values must be recorded on the Benchmark checklist, at the end of these instructions.

Once the gas rate and pressure have been confirmed as acceptable then the CO and combustion checks can be undertaken.

The flow chart is given for guidance, the details of the checks are given in the following sections:

- Checking flue integrity, (→ 6.9 "Checking flue integrity")
- Flue gas analysis, (→ 6.10 "Flue gas analysis")

NOTICE

Before CO and combustion checks:

- ▶ Verify the appliance is connected to the correct gas type.
- ▶ Ensure the appliance is supplied with the correct gas inlet pressure and gas rate as specified previously in the Commissioning section.
- ▶ Visually check the integrity of the whole flue system and confirm that all the components are correctly assembled, fixed and supported.
- ▶ The flue gas analyser must be the correct type as specified in BS 7967. Before use the analyser must have been calibrated as specified by the manufacturer. The installer must be competent in the use of the analyser.
- ▶ Check and zero the analyser in fresh air as specified by the manufacturer.
- ▶ The air/gas ratio valve is factory set and must not be adjusted during commissioning unless this action is recommended following contact with the Worcester, Bosch Group help line 0330 123 3366.

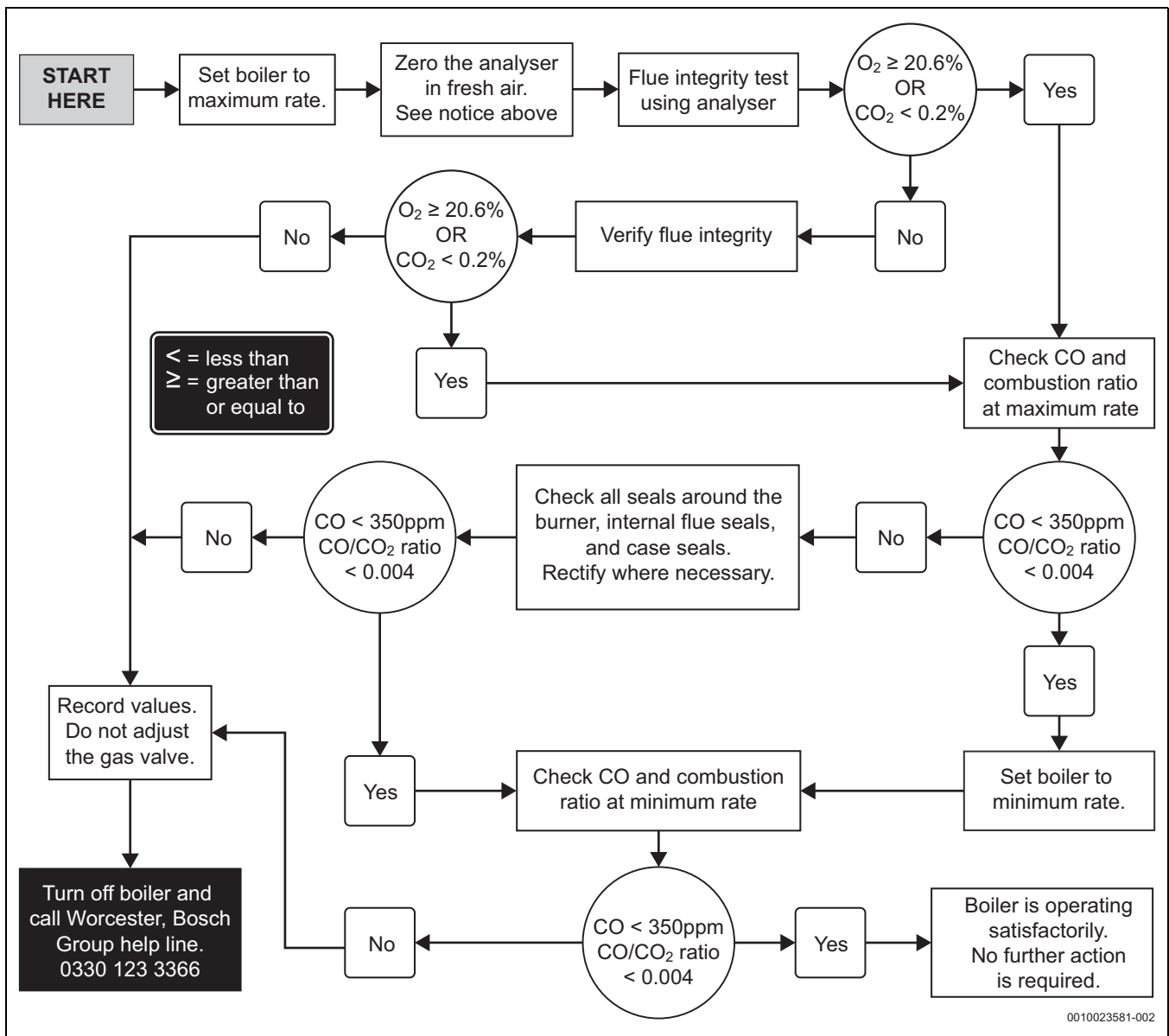

Fig. 67 Commissioning checks flow chart

6.9 Checking flue integrity



Flue integrity check

- ▶ The combustion casing must be fitted whilst this test is carried out.
- ▶ Refit the test point plugs after the test has been completed.

The integrity of the flue system and performance of the appliance can be checked via the flue turret/adaptor sample points.

Air inlet sample point location on flue turret/adaptor.

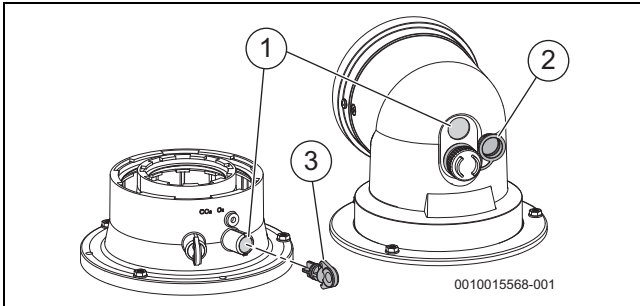

Fig. 68 Flue integrity check test point

- [1] Air inlet sample point
 - [2] Flue turret air inlet blank plug (with retaining ring)
 - [3] Flue adaptor air inlet blank plug
- ▶ With the appliance combustion casing on and the appliance running at maximum output in chimney sweep mode (→ chapter 6.4 "Chimney sweep mode"), remove the blanking plug [2 or 3] for the air inlet sample point [1].
 - ▶ Insert the analyser probe into the air inlet sample point [1].
 - ▶ Allow the readings to stabilise and check that:
 - O₂ is equal to, or greater than 20.6%
 - CO₂ is less than 0.2%
 - ▶ If the readings are outside these limits then this indicates that there is a problem with the flue system or combustion circuit.

6.10 Flue gas analysis

NOTICE

Combustion testing

- ▶ Combustion testing must be carried out by a competent qualified person. Testing must not be attempted unless the person carrying out the combustion check is equipped with a calibrated Flue Gas Analyser conforming to BS 7967 and is competent in its use.



Flue gas analysis

- ▶ Ensure that the gas inlet pressure has been checked and is satisfactory.
- ▶ Refit the test point plugs after the test has been completed.

The flue gas analysis performance of the appliance can be checked via the flue turret/adaptor sample points.

Refer to figure 69 for the location of the flue gas sample point on flue turret/adaptor.

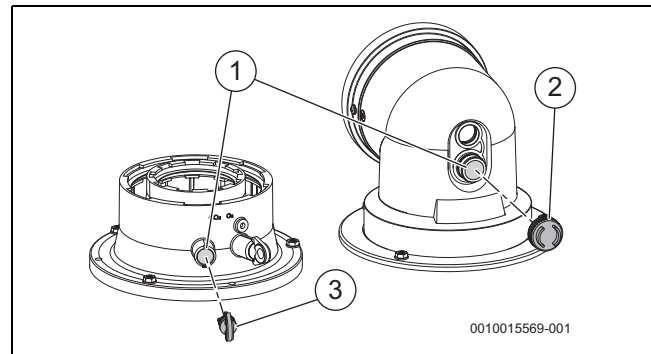

Fig. 69 Combustion test

- [1] Flue gas sample point
- [2] Flue turret flue gas blank plug
- [3] Flue adaptor flue gas blank plug

The CO and combustion ratio are checked;

- In chimney sweep mode at maximum output.
- In chimney sweep mode at minimum output.

Appliance to maximum output

- ▶ Set the appliance running at maximum output in chimney sweep mode (→ chapter 6.4 "Chimney sweep mode").

Appliance to minimum output

- ▶ Set the appliance running at minimum output in chimney sweep mode (→ chapter 6.4 "Chimney sweep mode").
 - Allow the appliance to stabilise at minimum output.

Measuring the CO and combustion ratio.

- ▶ Remove the blanking plug [2 or 3] for the flue gas sample point [1].
- ▶ Insert the analyser probe into the flue gas sample point [1].
 - Ensure that the probe reaches the centre of the flue gas exhaust, adjust the cone on the probe so that it seals the sample point and correctly positions the end of the probe.
- ▶ Check the CO and combustion readings.



Internal diverter valve: When running in maximum output in test mode, and the water temperature is 74°C or less, the appliance will operate both the central heating and DHW circuits with the internal diverter valve in the mid position. It will be necessary to run sufficient water through the DHW circuit to ensure that the appliance will not cycle on low heating demands. This is to allow sufficient time for the setting procedure. When the water temperature reaches 75°C the diverter valve will switch to CH only and will only return to the mid position if the temperature is 65°C or less.

External diverter valve/s: When the internal diverter valve is not fitted, it is recommended to position the external diverter valve in the central heating position.

6.11 Finishing commissioning

Fitting the front casing

- ▶ Fit the front casing making sure that the securing points are properly located.
 - Lift the front casing onto the locating bracket on the top of the appliance.
 - Push the bottom of the casing into position and tighten the bottom two screws [1].

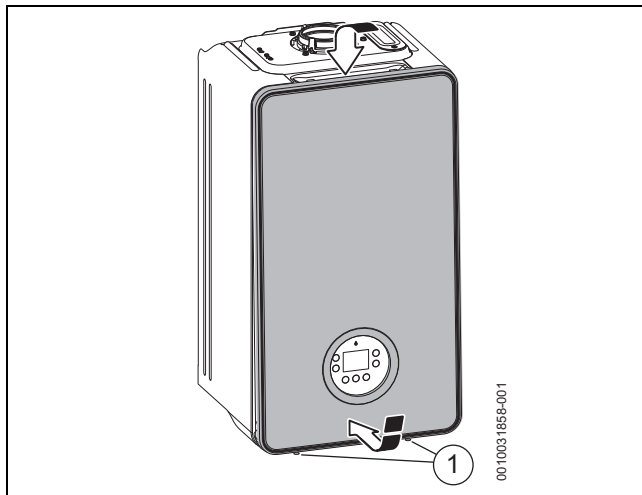

Fig. 70 Fitting the front casing



At the time of commissioning, complete all relevant sections of the Benchmark Checklist located in the Technical Specifications/Logs section of this document.

Benchmark menu

- ▶ Press and hold the **III** and **⏏** keys for approximately 3 seconds to enter the **Service menu**.
- ▶ Press the **ok** key to select the **Benchmark** menu.

Benchmark menu information:

- **Flow temp.**

Appliance handover:

- ▶ Complete the Benchmark Gas Boiler Commissioning Checklist.
- ▶ Show the customer the special features of the appliance.
- ▶ Show the customer the efficiency tips in the User Instructions.
- ▶ Set up the appliance controls and show the customer how to operate all the control unit/s for central heating and DHW operation.
 - Also show where in the appliance/controls documentation where this information can be found.
- ▶ Where applicable, instruct the customer on:
 - how to check the system pressure and re-pressurise if necessary.
 - how to set the TRVs.
 - how to reset the appliance.
- ▶ Show the customer the fault finding section in the User Instructions.
- ▶ Show the customer where the serial number/appliance information is located, they will need this information if they call in with a problem (Benchmark Commissioning checklist on page 92 contains all relevant appliance information).
- ▶ Give the customer details of how to contact the installer/ gas emergency numbers.
- ▶ Show the customer how to safely isolate the appliance.
- ▶ Advise the customer where they can find information on the Worcester, Bosch Group website www.worcester-bosch.co.uk.

- ▶ Ensure that all documentation, is left with the appliance or homeowner.
 - Appliance documentation.
 - Controls documentation.
 - Any other equipment documentation that is connected to the appliance or system.
- ▶ Appliance not in use
 - If the appliance is not going to be used immediately and may be exposed to freezing conditions, advise the customer of the precautions necessary to prevent damage to the appliance, system and building.
 - If the appliance is unused and exposed to freezing conditions, safely isolate all the mains supplies and drain the system and appliance, label accordingly.
- ▶ Show the customer the location of the condensate pipe run in unheated or external areas that may be at risk of freezing during prolonged cold spells.
- ▶ **User recommendation:**
 - Advise the user to have the appliance and heating system thoroughly serviced annually by a competent, registered gas engineer, such as a Gas Safe registered engineer or British Gas engineer. In the Republic of Ireland servicing work must be carried out by a Registered Gas Installer (RGI).
 - Present, where relevant, maintenance aids and reminders within the appliance menus.
 - Arrange an inspection/maintenance contract with an approved heating contractor.

Handover tool



To assist your customer with the handover of the boiler, including how to use its key features, please scan this QR code. QR code scanning apps are available for free on all platforms.

6.11.1 Appliance/product guarantee

This appliance/product has a guarantee against faulty materials or workmanship for a period from the date of installation subject to the terms and conditions.

For full terms and conditions, please visit:

www.worcester-bosch.co.uk/guarantee-terms-and-conditions

Guarantee registration

Your appliance/product carries a guarantee against faulty material or manufacture subject to Terms and Conditions.

To read the full Terms & Conditions please visit us on-line at www.worcester-bosch.co.uk/guarantee.

Your statutory rights are not affected by the manufacturer's guarantee



7 Settings in the service menu

Many appliance functions can be set and checked in the service menu. It includes:

- **Info:** viewing information
- **Settings:** general and appliance-specific settings
- **Function check:** settings for function checks and start of function checks
- **Reset:** restoring the factory settings, resetting the maintenance intervals
- **Demo mode:** mode for testing and demonstrating the functions. Power off appliance for exit.

7.1 Operating the service menu

Opening the service menu

- ▶ Press the  key and the  key simultaneously until the service menu appears.



Closing the service menu

- ▶ Press the  key or the  key.



-or-

- ▶ Press the  key.

Navigating through the menu

- ▶ To highlight a menu or a menu item, press the  key or the  key.
- ▶ Press the **ok** key.
The menu or the menu item is displayed.
- ▶ To return to the next higher menu level, press the  key.

Changing the setting values

- ▶ Select the menu item with the **ok** key.
- ▶ To select the desired value, press the  or the  key.
- ▶ Press the **ok** key.
The new value is saved.

Exiting the menu item without saving values

- ▶ Press the  key.
The value is not saved.
- ▶ Enter modified settings.
- ▶ Affix label to the appliance in a visible location.

7.2 Service menu

7.2.1 Overview of the service menu

Benchmark

- Flow temp.

Info

- Current status
- Current fault
- Fault history
- Boiler
 - Max. heat output
 - Actual temp.
 - Set flow temp.
 - HEx temperature
 - Act. burner mod.
 - Burner output
 - Ionisation current
 - Pump mod.
 - Outside temp.
 - Burner starts
 - Hours run
 - System pressure
- Hot water
 - Max. output
 - DHW act. temp.
 - S Act.temp. cyl. ¹⁾
 - DHW set temp. ¹⁾
- System
 - Contr.device ver.
 - Progr. unit ver.
 - SW sub-ver.
 - Code plug no.
 - Code plug ver.
 - Key ²⁾
- Solar ³⁾
 - Collector temp.
 - Cyl.temp.bottom
 - Collector pump
 - Solar fault

Settings

- Hydraulics
 - Low-loss header
 - DHW configuration
 - HC1 configuration
 - Pump config.
- Heating
 - Max. heat output
 - Standby time
 - Anticyc. temp. off
 - Anticycle temp. on
- Hot water
 - Max. output
 - DHW circ. pump
 - Cycle circ. pump
 - TD-Temperature
 - Start TD
- Pump
 - Pump range map
 - Pump ctr. mode
 - Min. output ⁴⁾
 - Max. output ⁴⁾
 - Pump overrun
- Special function
 - Ventilation func.
 - 3-WV mid. pos.
- Maintenance
 - Maintenance type
 - Without (off)
 - Burner run time
 - Boiler run time
 - Service date ²⁾
 - Landlord ²⁾
 - End date
 - Maint. reminder
 - Installer tel. no.
- Limit values
 - Max. flow temp.
 - Max. DHW temp.
 - Min. boiler outp.
- Heating curve
 - Enable
 - Htg. curve base
 - Htg. curve end
 - Summer mode
 - Frost prot.
 - Frost temp. limit

1) Menu item only visible if integral diverter kit is fitted.

2) Only available with installed Key Timer (accessory).

3) Not available in every system configuration.

4) Available when **Pump range map** has been changed to **Output dependent**

Function check

- Activate test ¹⁾
 - Burner
 - Ignition
 - Fan
 - Pump
 - 3-way valve
 - Ionisat.oscill.
 - HC1 pump ¹⁾
 - DHW circ. pump ¹⁾
 - Solar pump ¹⁾
-

Reset

- Default setting
 - Fault history
 - Service display ²⁾
 - Hidden menu: Reset Maintenance Landlord
-

Demo mode

- Yes
 - No
-

1) When the Function Check menu is entered only **Burner** will be visible for the first 10 seconds, after this period of time the other components that can be tested will appear in the menu. Components such as HC1 pump, DHW circulation pump and Solar pump will show if connected to the control board.

2) Available when **Maintenance** has been activated

7.2.2 Benchmark and Info menu

Menu item	Remark/restriction
Flow temp.	Flow temperature in °C

Table 22 Benchmark menu

Menu item	Remark/restriction
Current status	→ 10.1.2 "Operating/Fault code table", page 71 for operating codes.
Current fault	→ 10.1.2 "Operating/Fault code table", page 71 for fault codes.
Fault history	Last 10 faults in chronological order
Boiler	
Max. heat output	Maximum heating output in kW
Actual temp.	Current flow temperature in °C
Set flow temp.	Target flow temperature in °C
HEx temperature	Primary heat exchanger temperature
Act. burner mod.	Current burner modulation %
Burner output	Current burner output in kW
Ionisation current	Current ionisation current in µA
Pump mod.	Current pump modulation %
Outside temp.	Current outside temperature in °C
Burner starts	Number of burner starts since commissioning
Hours run	Run time of the system since commissioning
System pressure	Current operating pressure in bar
Hot water	
Max. output	Maximum domestic hot water output in kW
DHW act. temp. ¹⁾	Current domestic hot water temperature in °C
S Act. temp. cyl. ¹⁾	Current domestic hot water temperature in °C
DHW set temp. ¹⁾	DHW temperature setting value
System	
Contr. device ver.	Software version of the control device
Progr. unit ver.	Software version of the control unit
SW sub-ver.	Software sub-version
Code plug no.	Code plug number
Code plug ver.	Code plug version
Key ²⁾	Type of control Key installed e.g. "Comfort+RF Key"
Solar ³⁾	
Collector temp.	Collector temperature in °C
Cyl. temp. bottom	Cylinder temperature, bottom sensor in °C
Collector pump	Collector pump
Solar fault	Current faults

1) Menu item only visible if integral diverter kit is fitted.

2) Only available with installed Key Timer (accessory)

3) Menu items only visible if Solar connected

Table 23 Info menu

7.2.3 Settings menu

The menu is adapted to your system automatically. Some menu items are only available if the system has been set up accordingly. The menu items are only displayed in systems in which the corresponding system components are installed, e.g. Key Timer.



The factory settings are **highlighted** in the following table.

Menu item	Settings/adjustment range	Comment/restriction
Hydraulics		
Low-loss header	• Off	Not used
DHW configuration	• Not installed • 3-way valve installed • Cyl. primary pump installed	The factory default for installations without the optional diverter valve kit, is "Not installed", Where the optional diverter valve kit is installed, the boiler will automatically detect its presence and adjust the default setting to "3-way valve installed"
HC1 configuration	• No dedicated pump installed	Not used
Pump config.	• None • Heating pump	
Heating		
Max. heat output	• 50... 100 %	Maximum released thermal output [%] (heating). On natural gas appliances: ▶ Measure the gas rate. ▶ Correct deviations.
Standby time	• 3... 10 ...60 minutes	The time interval determines the minimum delay between starting and restarting the burner.
Anticyc. temp. off	• 2 ... 6 ... 15 K	The difference between the current flow temperature and the set flow temperature until the burner is switched off.
Anticycle temp. on	• -15 ... -5 ... -2 K	The difference between the current flow temperature and the set flow temperature until the burner is switched on.
Hot water		
Max. DHW output	• 50... 100 %	Maximum power on hot water
DHW circ. pump	• Off • On	No functionality; not used.
Cycle circ. pump	• 1 x 3 minutes/h • 2 x 3 minutes/h • 3 x 3 minutes/h • 4 x 3 minutes/h • 5 x 3 minutes/h • 6 x 3 minutes/h • Permanent	Menu only visible if DHW circ. pump is installed and set to "On" Number and duration of hot water circulation pump starts per hour
TD-Temperature	• 60... 70 °C	Thermal Disinfection hot water temperature set point.
Start TD	Start now?	Start legionella protection cycle ▶ Perform thermal disinfection (→ Chapter 7.3, page 58).
Stop TD	Cancel now?	Stop legionella protection cycle
Pump		
Pump range map	• 0: Pump output proportional to the heat output • 1: constant pressure 150 mbar • 2: constant pressure 200 mbar • 3: constant pressure 250 mbar • 4: constant pressure 300 mbar • 5: constant pressure 350 mbar • 6: constant pressure 400 mbar	▶ In order to save energy and to keep potential flow noises to a minimum, set a low pump curve (→ Chapter 13.5, page 89).
Pump ctr. mode	• Energy saving • Heat demand	• Save energy: intelligent shutdown of heat pump for heating systems with weather-compensated controller. The heating pump is only switched on if required. • With heat demand: the flow temperature controller switches the heating pump. When there is heat energy demand, the heating pump starts up with the burner.

Menu item	Settings/adjustment range	Comment/restriction
Min. output	<ul style="list-style-type: none"> • 10 ... 30 % 	Pump output at minimum heat output. Only available with pump map 0 (output-dependent control).
Max. output	<ul style="list-style-type: none"> • Min. output ... 100% 	Pump output at maximum heat output. Only available with pump characteristic map 0. <ul style="list-style-type: none"> • Can only be reduced to value set in Min. output.
Pump overrun	<ul style="list-style-type: none"> • 1 ... 2 ... 60 min, 24 h 	Overrun time of the heating pump: pump overrun begins when heat demand ends.
Special function		
Ventilation func.	<ul style="list-style-type: none"> • Off • Auto • On 	The venting function can be switched on after maintenance work. During ventilation, the following appears in the info area of the standard display Ventilation func.
3-WV mid. pos.	<ul style="list-style-type: none"> • No • Yes 	The function ensures that the system is fully drained and that the motor can be easily removed. The 3-way valve remains at the middle position for approx. 15 minutes.
Maintenance		
Maintenance type	<ul style="list-style-type: none"> • Without (off) <ul style="list-style-type: none"> – No reminder. • Burner run time: 1000 ... 6000 h <ul style="list-style-type: none"> – Service reminder based on the number of hours the burner has been active, (1000 hours up to 6000 hours, default 6000 hours). • Boiler run time: 1 ... 12 ... 72 months <ul style="list-style-type: none"> – Service reminder based no the number of months the boiler has been operating, (1 month up to 72 months (6 years), default 12 months). • Service date¹⁾ <ul style="list-style-type: none"> – Service reminder where a specific calendar date can be selected. • Landlord <ul style="list-style-type: none"> – Operates in the same way as service date with the additional option of reducing CH and DHW comfort. 	Landlord: This menu item allows a date to be set for annual service/maintenance (End date). The service display appears as a reminder 30 days before the scheduled date. A contact telephone number (Installer tel. no.) is shown together with service display. The tenant should call this number to arrange a suitable maintenance date. A second reminder appears at the scheduled date. If the service display is not reset by the service engineer, the control unit limits the functions 14 days after the scheduled date. Reduced functions are set at Maint. reminder: <ul style="list-style-type: none"> • DHW reduced: reduced comfort (max. 35 °C flow temperature) • Boiler off: central heating and hot water functions are set off.
Limit values		
Max. flow temp.	<ul style="list-style-type: none"> • 30 ... 82 °C 	Limits the maximum flow temperature.
Max. DHW temp.	<ul style="list-style-type: none"> • 35 ... 60 °C 	Limits the maximum domestic hot water temperature.
Min. boiler outp.	<ul style="list-style-type: none"> • “Minimum rated output” ... increases up to 30% 	Minimum heat output depending on code plug, Max = 30%.
Heating curve		
Enable	<ul style="list-style-type: none"> • Yes • No 	To turn this function on, when connecting a weather sensor, select Yes to enable. The system control unit optimises this setting. This service function activates a simple, weather-compensated controller with a linear heating curve. Depending on the on/off input, the heating is switched on or off.
Htg. curve base	<ul style="list-style-type: none"> • 20 ... 90 °C 	This is only displayed if the heating curve has been enabled. This can be used to set the flow temperature base point of the heating curve, which corresponds to an outside temperature of +20 °C.
Htg. curve end	<ul style="list-style-type: none"> • 20 ... 90 °C 	This is only displayed if the heating curve has been enabled. This can be used to set the flow temperature end point of the heating curve, which corresponds to an outside temperature of -10 °C.
Summer mode	<ul style="list-style-type: none"> • 0 ... 16 ... 30 °C 	This is only displayed if the heating curve has been enabled. This can be used to set the outside temperature threshold at which the heating system switches to summer mode i.e. heating off.

Menu item		Settings/adjustment range	Comment/restriction
	Frost prot.	<ul style="list-style-type: none"> • Yes • No 	This activates frost protection based on measured outdoor temperature.
	Frost temp. limit	<ul style="list-style-type: none"> • 0 ... 5 ... 10 °C 	Temperature value for the system frost protection. This service function is only available if the frost protection function was activated. If the outside temperature does not exceed the frost threshold temperature, then the heating pump in the heating circuit switches on.

1) Only available with installed Key Timer (accessory)

Table 24 Settings menu

7.2.4 Menu Function check



Visibility of the **Activate test** sub-menus.

- ▶ The **Burner** test will appear instantly in the sub-menu and after a further 10 seconds the other components that can be tested will appear in the menu.

Menu item	Settings/adjustment range	Remark/restriction
Activate test		
Burner	<ul style="list-style-type: none"> • Off ...100 % 	This service function enables you to test the burner by adjusting the appliance output.
Ignition	<ul style="list-style-type: none"> • On • Off 	Permanent ignition. Testing the ignition by means of permanent ignition without gas supply. ▶ To prevent damage to the ignition transformer: leave the function switched on for a maximum of 2 minutes .
Fan	<ul style="list-style-type: none"> • On • Off 	Permanent fan operation. Fan runs without gas supply or ignition.
Pump	<ul style="list-style-type: none"> • On • Off 	Permanent pump operation.
3-way valve	<ul style="list-style-type: none"> • Heating • Hot water 	Permanent position of the 3-way valve.
Ionisat.oscill.	<ul style="list-style-type: none"> • On • Off 	Check the ionisation measurement function at the flame.
HC1 pump ¹⁾	<ul style="list-style-type: none"> • On • Off 	Only available if a pump is connected to the corresponding boiler control unit input. Selecting "On" will permanently run the pump until switched off.
DHW circ. pump ¹⁾	<ul style="list-style-type: none"> • On • Off 	Only available if a pump is connected to the corresponding boiler control unit input. Selecting "On" will permanently run the pump until switched off.
DHW circ. pump ¹⁾	<ul style="list-style-type: none"> • On • Off 	Permanent DHW circulation pump operation.
Solar pump ¹⁾	<ul style="list-style-type: none"> • On • Off 	Only available if a pump is connected to the corresponding boiler control unit input. Selecting "On" will permanently run the pump until switched off.

1) Components will show if connected to the control board.

Table 25 Menu Function check

7.2.5 Reset menu

Menu item	Settings/adjustment range	Remark/restriction
Default setting	Restore?	Restore factory settings. The system needs to be re-commissioned following this reset!
Service display ¹⁾	Reset?	Reset maintenance period.
Fault history	Delete?	Reset the maintenance first. The fault history is deleted. Unresolved faults will re-appear after fault history reset

1) Service display sub-menu only available if maintenance options have been selected.

Table 26 Reset menu

7.2.6 Menu Demo mode

Demo mode enables users to navigate through the boiler menus without gas or water supplied to the boiler. Demo mode is designed to increase product familiarity in a pre-sales environment.

Menu item	Settings/adjustment range	Remark/restriction
Demo mode	<ul style="list-style-type: none"> • Yes • No 	▶ To exit Demo mode: switch the device off and back on.

Table 27 Menu Demo mode

7.3 Thermal disinfection

To prevent hot water from becoming contaminated by bacteria such as legionella, we recommend thermal disinfection after long downtimes.

CAUTION

Risk of scalding:

During thermal disinfection, discharging unmixed hot water can cause serious scalding.

- ▶ Run thermal disinfection at the factory default temperature of 70 °C for a minimum of 3 minutes.
- ▶ Inform occupants of the premises of the risk of scalding.
- ▶ Perform thermal disinfection outside of the normal operating times.
- ▶ Do not discharge DHW unmixed.



To prevent the risk of scalding and to ensure mixed hot water, it is advisable to fit a thermostatic mixing valve (TMV) at the point of use (e.g. before the bath hot tap or shower).

Proper thermal disinfection involves the DHW system including the draw-off points.

- ▶ Set the thermal disinfection in the service menu or hot water program of the heating controller (→ heating controller operating instructions).
- ▶ Close DHW draw-off points.
- ▶ Set any DHW circulation pump to continuous operation.
- ▶ Wait until the maximum temperature is reached.
- ▶ Open all DHW draw-off points, from the nearest to the one furthest away, and draw off hot water until hot water at a minimum of 70 °C has flown from all draw-off points for at least 3 minutes.
- ▶ Restore the original settings.

8 Inspection and maintenance

DANGER

Risk of electric shock!

- ▶ Isolate electrical components from the power supply (230 V AC) (fuse, circuit breaker) and secure against unintentional re-connection before carrying out any work. Information on safe isolation can be found in the Health and Safety Executive guidance HSG85.
- ▶ Check for zero potential before proceeding with work, using test equipment approved to GS38 to confirm that the electricity supply is disconnected.

CAUTION

Mains supplies:

- ▶ Safely isolate both the gas and electrical supply before starting any work on the appliance and observe all relevant safety precautions.

NOTICE

Personnel and equipment

- ▶ Any service work must be carried out by competent registered engineers.
- ▶ Service work must not be attempted if a calibrated CO/CO₂ analyser and manometer are not available.

WARNING

Hot surfaces!

If the appliance has been operating components may be hot.

- ▶ Ensure precautions are taken when working on the appliance.

CAUTION

Annual maintenance checks:

Annual maintenance checks have to be conducted to ensure the continued safe and reliable operation of the boiler.

- ▶ During each maintenance check, the gas valve, all gas joints and test points should be checked for leakage using an analyser/sniffer.
- ▶ If a leak is found on the gas valve then it needs replacing as a gas valve is a non-repairable component.

CAUTION

Component replacement:

- ▶ After replacement of a gas related component, where a gasket or seal has been disturbed or replaced, check for gas tightness using a gas sniffer/analyser.
- ▶ Also after re-assembly, carry out the following checks:
 - Fan pressure.
 - Flue gas analysis.

8.1 Inspection and maintenance considerations

- To ensure continued efficient operation the appliance must be checked at regular intervals.
- The frequency of servicing will depend upon the particular installation conditions and usage, however, at least an annual service is recommended.
- The extent of the service work required on the appliance is determined by the operating condition of the appliance when tested by qualified engineers.
- After each service, the service interval record sheet at the rear of this manual, must be completed.

See the following instructions for detail of some of the service requirements:

- ▶ Check all joints and connections in the system and remake any that show signs of leakage. Refill and re-pressurise if applicable as described in the commissioning section.
- ▶ When it is frequently necessary to add water to maintain pressure in the installation, even though no leaks have been discovered, perform an expansion vessel check.
- ▶ Check that the condensate system is not obstructed, clean and refill the condensate siphon.
- ▶ If the appliance is in a compartment or cupboard check that the specified clearances around the appliance is clear.
- ▶ Check that the flue system is unobstructed and undamaged, clean/replace as necessary.
 - If fitted ensure the flue terminal guard is also unobstructed and undamaged.
- ▶ Operate the appliance and take note of any irregularities.
 - Refer to the fault finding pages for rectification procedure.

Maintenance reminder options

Accessing the maintenance reminder options.

- ▶ **Service menu > Settings > Special function > Maintenance.**

Options available.

- **Without (off)**
 - No reminder.
- **Burner run time**
 - Service reminder based on the number of hours the burner has been active, (1000 hours up to 6000 hours, default 6000 hours).
- **Boiler run time**
 - Service reminder based on the number of months the boiler has been operating, (1 month up to 72 months (6 years), default 12 months).
- **Service date** (Only available with installed Key Timer (accessory))
 - Service reminder where a specific calendar date can be selected.
- **Landlord function** (only available with installed Key Timer (accessory)).
 - Operates in the same way as service date with the additional option of reducing CH and DHW comfort.

Maximum system pressure

- ▶ 2.5 bar must not be exceeded when the heating system water is at maximum temperature. If this pressure is exceeded then an additional expansion vessel must be fitted into the system return as close as possible to the appliance.
- ▶ If the system does not retain the pressure, the pressure relief valve (PRV) and the heating system should be checked for leaks.

8.2 Component access

Removing the front casing



The front casing is secured with two screws which are critical to maintain the case seal and to prevent unauthorised removal (electrical safety).

- ▶ Always secure the casing with these screws.
- ▶ Loosen the two screws [1] and pull the bottom of the casing forward.
- ▶ Lift off the casing.

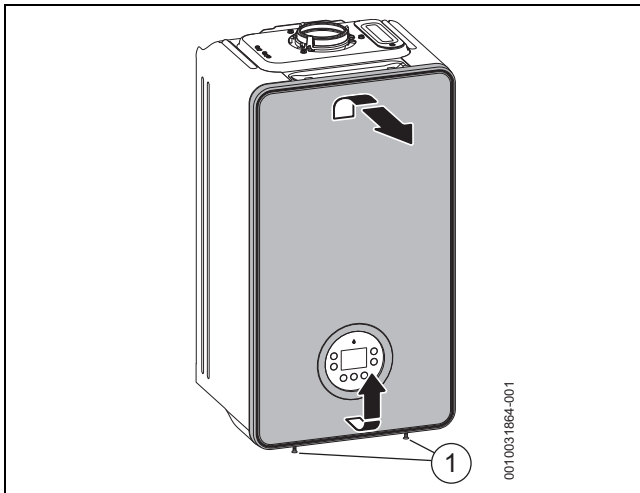

Fig. 71 Removing the front casing

8.3 Checking heat exchanger assembly

- ▶ Remove the front casing.
- ▶ Remove the cap from the test nipple, and connect a pressure gauge.

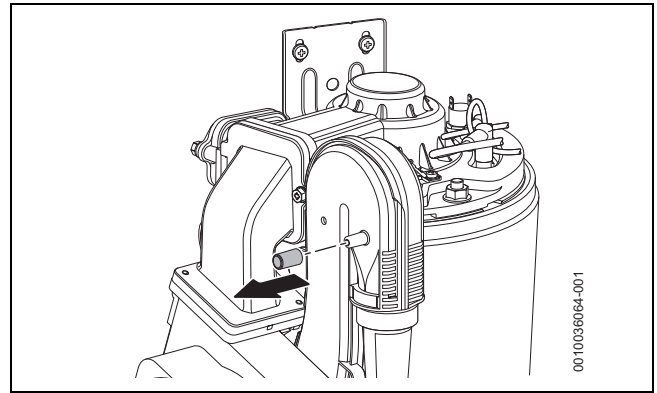

Fig. 72 Test nipple at the mixing device

NOTICE

Fan pressure test

- ▶ The appliance must be running at maximum output in chimney sweep mode for the fan pressure test, (→ Setting the appliance to maximum).



This test is to determine if the heat exchanger requires cleaning or additional actions.



Fan pressure test reading.

- ▶ The pressure reading will be in negative values.

Appliance fan pressure test values

Natural Gas appliances

Appliance output	Cleaning required		No cleaning required	
	Value			
24kW	0 mbar	↔ -3.4 mbar	-3.5 mbar	⇒ -12 mbar
21kW	0 mbar	↔ -2.7 mbar	-2.8 mbar	⇒ -12 mbar
18kW	0 mbar	↔ -2.0 mbar	-2.1 mbar	⇒ -12 mbar
15kW	0 mbar	↔ -4.2 mbar	-4.3 mbar	⇒ -12 mbar
12kW	0 mbar	↔ -2.8 mbar	-2.9 mbar	⇒ -12 mbar

Table 28 Natural Gas values

LPG appliances

Appliance output	Cleaning required		No cleaning required	
	Value			
24kW	0 mbar	↔ -4.2 mbar	-4.3 mbar	⇒ -12 mbar
21kW	0 mbar	↔ -3.3 mbar	-3.4 mbar	⇒ -12 mbar
18kW	0 mbar	↔ -2.5 mbar	-2.6 mbar	⇒ -12 mbar
15kW	0 mbar	↔ -5.0 mbar	-5.1 mbar	⇒ -12 mbar
12kW	0 mbar	↔ -3.4 mbar	-3.5 mbar	⇒ -12 mbar

Table 29 LPG values

If the manometer reading is within tolerance, in the white area of the table values.

- ▶ The heat exchanger/exhaust path/siphon does not require attention.

If the manometer reading is out of tolerance, in the shaded area of the table values then carry out the following checks.

- ▶ Check that the siphon is not restricted or blocked.
- ▶ Check the exhaust paths for restrictions.
- ▶ Clean the heat exchanger with a suitable cleaning tool, refer to cleaning section.
- ▶ Re-check the fan pressure readings.
If the appliance, after completing the above checks, fails the fan pressure test then contact Worcester, Bosch Group for advice.
- ▶ Switch the appliance off after completing pressure check.
- ▶ Disconnect the digital manometer and replace the test point cover.

8.4 Check working gas inlet pressure

NOTICE

Gas inlet pressure

- ▶ Do not continue with the other checks if the correct gas inlet pressure can not be achieved at maximum output.

- ▶ Check the gas supply working pressures in the system conform to the readings shown in the table shown in chapter 6.5 "Checking gas inlet pressure".

8.5 Flue gas analysis

NOTICE

Combustion testing

- ▶ Combustion testing must be carried out by a competent person. Testing must not be attempted unless the person carrying out the combustion check is equipped with a calibrated flue gas analyser conforming to BS 7967 and is competent in its use.



Flue gas analysis

- ▶ Ensure that the gas inlet pressure has been checked and is satisfactory.
- ▶ Refit the test point plugs after the test has been completed.

- ▶ Set the appliance to maximum and minimum output in chimney sweep mode (→ 6.4 "Chimney sweep mode") for the flue gas analysis checks.
- ▶ Check that the readings conform to those given in the following tables. In addition to CO and CO/CO₂ ratio checks also check the maximum and minimum CO₂ percentage reading.

CO/CO₂ settings

CO ₂ Reading	CO Reading
Natural Gas appliances	
Maximum rated Output ¹⁾	
Between 9.0 and 9.8%	<250ppm
Minimum rated Output ¹⁾	
A minimum of 0.2 lower than the maximum reading taken and between 8.2 and 9.0%	<250ppm
LPG appliances	
Maximum rated Output ¹⁾	
Between 10.4 and 11.0%	<250ppm
Minimum rated Output ¹⁾	
A minimum of 0.2 lower than the maximum reading taken and between 10.0 and 10.4%	<250ppm

1) Should be measured 10 minutes after firing the appliance

Table 30 CO₂ settings

If the CO₂ is out of tolerance then please check:

- ▶ The gas inlet pressure.
- ▶ The gas rate.
- ▶ The fan test pressure.
- ▶ The flue and air intake, plus any possible blockages in the condensate disposal.
- ▶ The condition of burner.
- ▶ For leaks or obstructions in the exhaust paths.
- ▶ That the injector is clean.

After all checks have been completed and the CO₂ is still out of tolerance then contact Worcester, Bosch Group helpline 0330 123 3366 before making any adjustment to the gas valve.

8.6 Checking the flue integrity

NOTICE

- ▶ Check flue joints are secure, the terminal and the terminal guard, if fitted are clear and undamaged.
- ▶ Combustion testing must be carried out to BS 7967 by a competent person. Testing must not be attempted unless the person carrying out the combustion check is equipped with a calibrated Combustion Analyser conforming to BS EN 50379 and is competent in its use.



Flue gas analysis

- ▶ Ensure that the gas inlet pressure has been checked and is satisfactory.
- ▶ Refit the test point plugs after the test has been completed.

- ▶ Refer to chapter 6.9 "Checking flue integrity" and check that the readings conform to those given, confirming flue system and combustion circuit are ok.

8.7 Cleaning the siphon and heat exchanger

8.7.1 Checking the electrodes and cleaning the heat exchanger



CAUTION

Risk of burns due to hot surfaces!

Individual components of the appliance can become very hot even after being shut down for a long time.

- ▶ Allow the appliance to cool down before carrying out any work.
- ▶ If necessary, wear protective gloves.



WARNING

Material damage due to hot flue gas! - Gaskets and seals - gas related components

Hot flue gas can leak through defective gaskets, damage the appliance and endanger safe operation.

- ▶ Burner/electrode assembly gasket must be replaced if disturbed.
- ▶ Other gaskets/seals must be checked and replaced where necessary.
- ▶ Do not attempt the cleaning procedure unless new gaskets and seals are available.
- ▶ Ensure that the gaskets are positioned correctly.

NOTICE

Material damage due to chemicals

Using chemicals during the cleaning of the heat exchanger assembly and associated parts or carrying out maintenance can damage the sealing components. This can cause exhaust gas to escape during operation.

- ▶ Do not use chemicals to flush the heat exchanger assembly and associated gas carrying components.



It is recommended to use the cleaning tool accessory, comprising of brush and lifting tool to assist in cleaning the heat exchanger assembly. Part number 7 733 600 091.

Refer to figure 73.

- ▶ Disconnect the electrical connection [3] from the fan.
- ▶ Remove the gas hose [2] from the venturi nozzle.
- ▶ Remove the screw [1] on the mixing device.
- ▶ Remove the fan with mixing device [4].

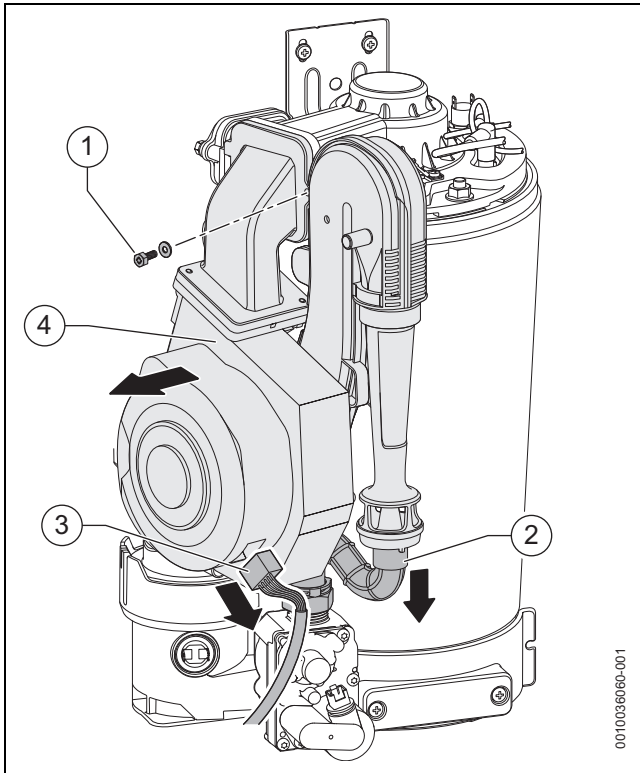

Fig. 73 Removing the fan with mixing unit

Refer to figure 74.

- ▶ Pull off cables from the electrode set [2].
- ▶ Pull off cable [1].
- ▶ Remove M8 nut [3].
- ▶ Remove the burner cover [4].



On re-assembly, to ensure a full gas tight seal, tighten the M8 nut down firmly, without over tightening.

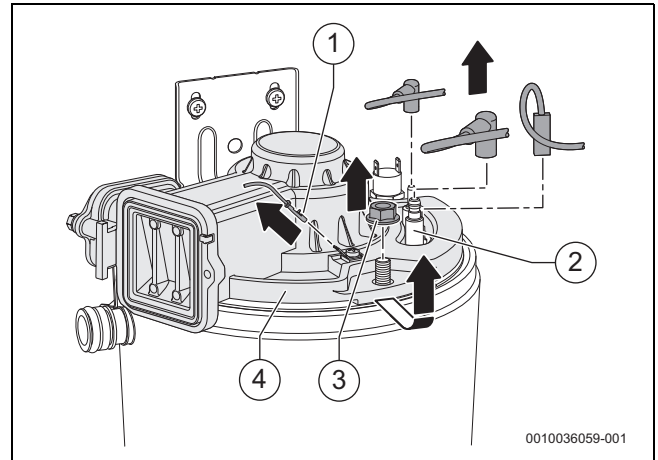

Fig. 74 Remove the burner cover

Refer to figure 75.

- ▶ Remove the non-return valve (bearing plate) [1].
 - Check for damage/cracks or deformation and for contamination, replace if required.
 - Ensure non-return valve moves freely.

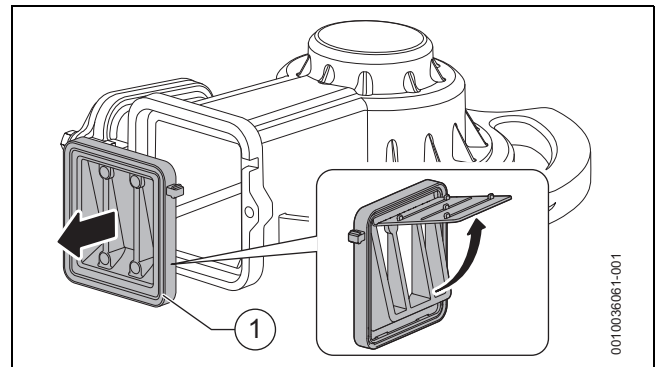

Fig. 75 Non-return valve (bearing plate) in the mixing unit

Refer to figure 76.

- ▶ Remove the gasket.
- ▶ Remove electrode set [2].
 - Check for damage or deformation, replace if required.
 - Check electrodes for contamination, clean or replace, if required.
- ▶ Remove the burner [3].

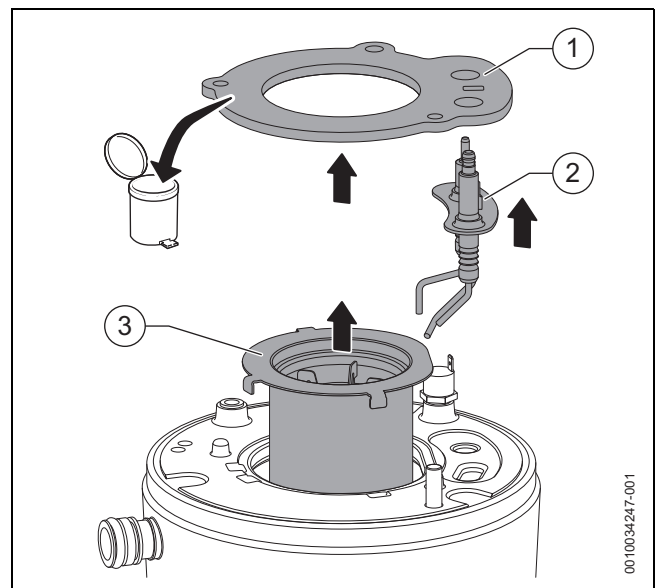

Fig. 76 Removing the burner

Refer to figure 77.

- ▶ Remove the top baffle using the lifting device.
- ▶ Remove the bottom baffle using the lifting device.

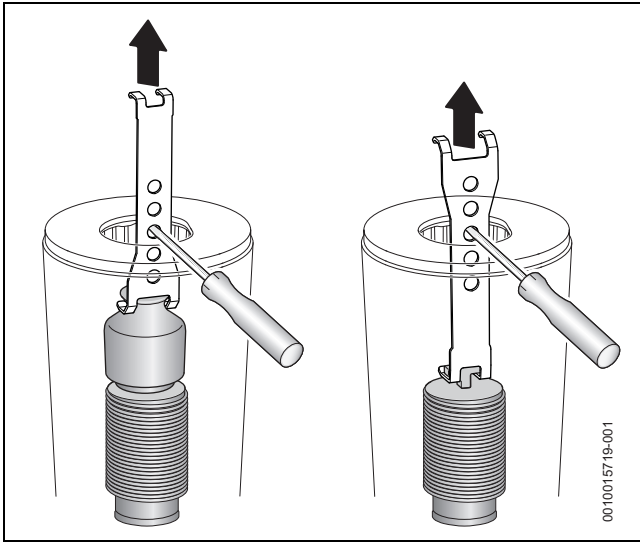

Fig. 77 Remove the top and bottom baffles

- ▶ Check for damage or deformation and then clean both baffles.

Refer to figure 78.



To gain better access from above, remove inspection aperture from the top panel of the appliance.

- ▶ Clean the heating exchanger with the brush:
 - by rotating in both directions
 - from top to bottom
- ▶ Remove the screws from the inspection aperture cover and remove with the seal.

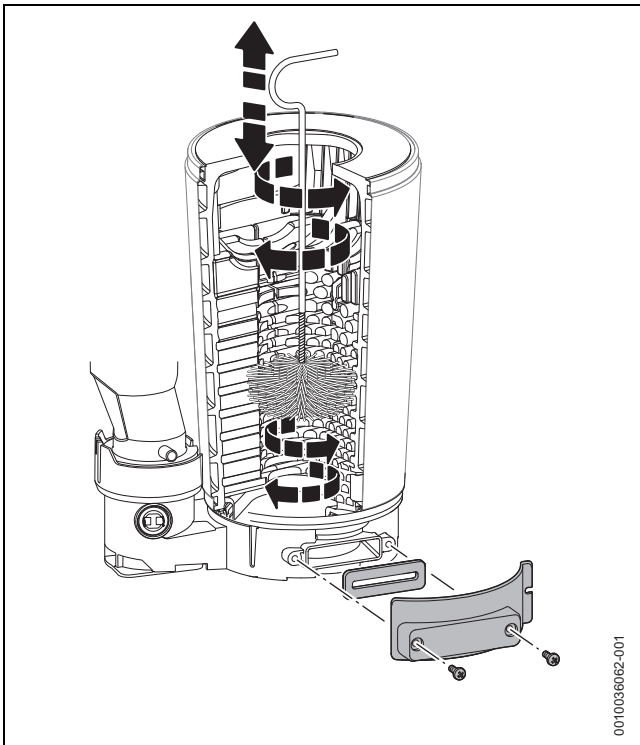

Fig. 78 Cleaning the heat exchanger

- ▶ Clean out residue and re-fit the inspection aperture again.

Refer to figure 79.

- ▶ Rinse the heat exchanger with water from the top.

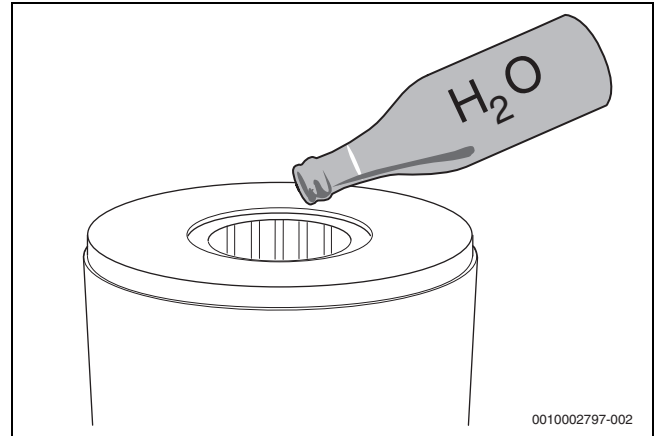

Fig. 79 Rinse the heat exchanger with water

Refer to figure 80.

- ▶ Re-open inspection aperture and ensure no residue remains.
 - Close the inspection aperture once checked.

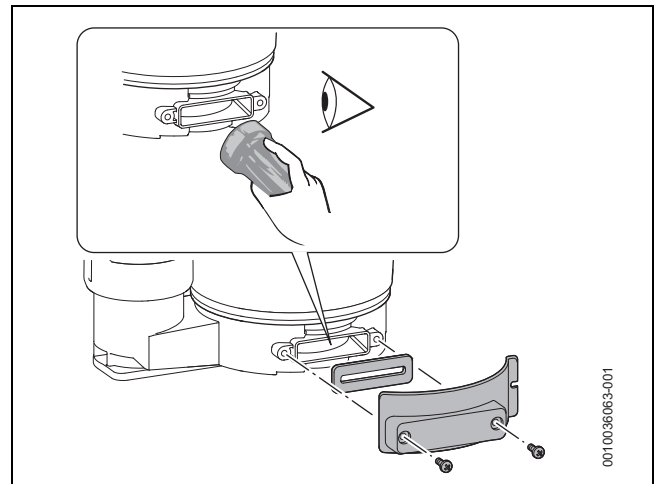

Fig. 80 Checking the heat exchanger for residue

- ▶ Refit the cleaned baffles.
- ▶ Clean the condensate trap before carrying out the following checks (→ section 8.7.2).
- ▶ Check that pathways are clear by carrying out Checking heat exchanger assembly, (→ section 8.3).
- ▶ Check and adjust if required the gas/air ratio.

8.7.2 Cleaning the condensate trap

! WARNING

Danger to life due to poisoning!

If the condensate trap is not filled, poisonous flue gas can escape.

- ▶ Fill the condensate trap with approximately 250 ml water before refitting.
- ▶ Make sure that the condensate discharge drains off properly.

i

Damage resulting from an insufficiently cleaned trap is excluded from the warranty.

- ▶ Check and clean the siphon during regular maintenance.

Removing the siphon.

Refer to figure 81.

- ▶ Disconnect the discharge elbow [3] from the siphon.
- ▶ Place a suitable container below the siphon outlet to catch any water.
- ▶ Whilst supporting the siphon [2], press the locking lever [1] to the unlock position.
- ▶ Release the siphon [2] from the connection.
- ▶ Tip the siphon backwards to empty any condensate which will be discharged whilst removing the siphon from the appliance.
- ▶ Remove the siphon.

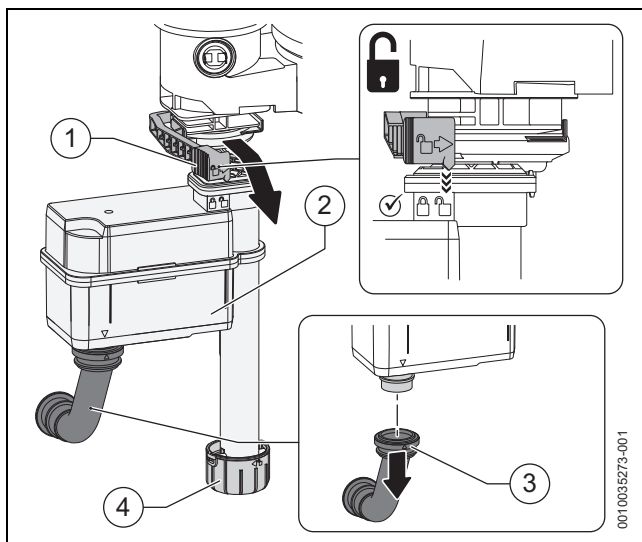

Fig. 81 Removing the siphon

- ▶ Clean the condensate siphon.
- ▶ Remove the dirt trap [4] (→ figure 81) at the bottom and clean it.
 - Check dirt trap gasket for cracks, deformation or breakage, replace if required.
- ▶ Refit the dirt trap and check that it is correctly seated.
- ▶ Check that the opening to the heat exchanger is clear.

Replacing siphon gasket.

Refer to figure 82.

- ▶ Remove the gasket on the top of the siphon.
- ▶ Check the gasket for cracks, deformation or breakage and replace if required.
- ▶ Align the gasket [1] correctly with the siphon.

- ▶ Push the gasket [1] into the recess and ensure it is correctly inserted.

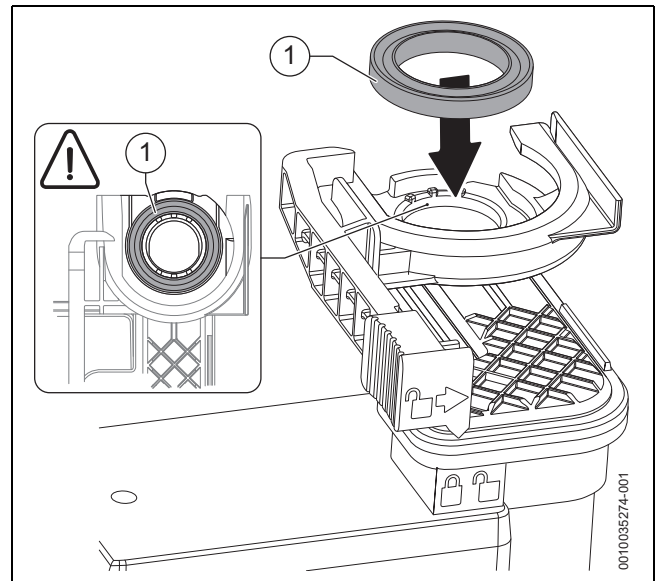

Fig. 82 Replacing the gasket

Refitting the siphon.

Refer to figure 83.

- ▶ Check the condition of the discharge elbow.
 - Check for cracks, deformation or breakage, replace if required.
 - Clean discharge elbow if required.
- ▶ Fit the discharge elbow to the 25mm condensate pipework protrusion on the wall frame.
- ▶ Fill the condensate siphon with approx. 250 ml water.
- ▶ Fit the condensate siphon [1]. Ensure the alignment arrow on the locking arm is in the locked position.
 - Ensure the condensate siphon is secured correctly.
- ▶ Fit the discharge elbow [2] onto the outlet, ensuring the locating arrows are aligned.

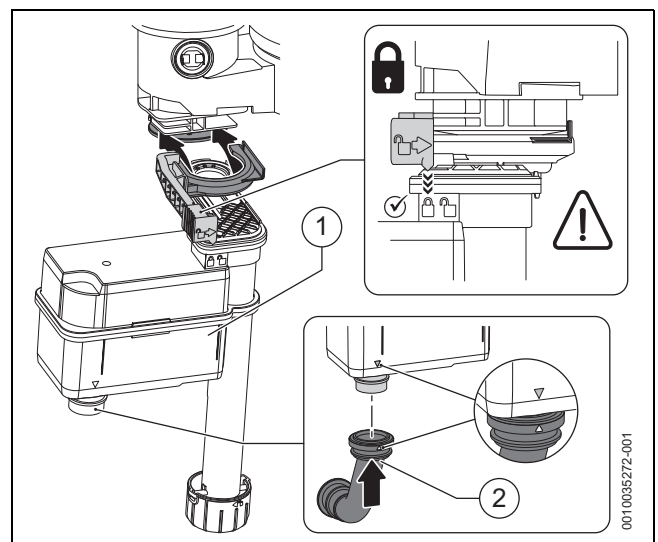

Fig. 83 Refitting the siphon

8.8 Setting the air/gas ratio

NOTICE

Setting the air/gas ratio

- ▶ The air/gas ratio is factory set and should not need to be adjusted. If found to be out of tolerance and when all other possible causes have been checked, please contact the Worcester Bosch Group helpline 0330 123 3366.

NOTICE

Combustion testing

- ▶ The checking of the air/gas ratio **must** be carried out by a competent registered gas engineer, such as a Gas Safe registered engineer or British Gas engineer.
- ▶ Checking of the air/gas ratio **must not** be attempted unless the person carrying out the test is equipped with a flue gas analyser conforming to BS7927 and is competent in its use.



All CO/CO₂ readings must be taken with the combustion chamber cover ON.

Adjustments can only be made with the cover off.



CO₂ should be measured 10 minutes after firing the appliance.

Adjusting the minimum rated output settings

With the appliance in minimum rated output.

- ▶ Remove the seal from the adjusting screw of the gas valve (only gas valve is shown in the below Figure 84) and set the CO₂ content for minimum rated output.

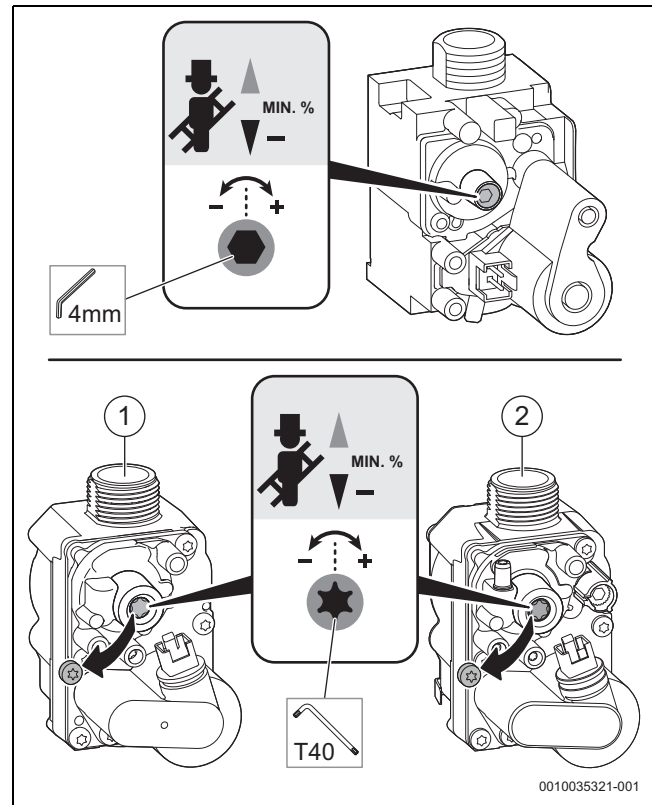

Fig. 84 Setting the CO₂ content (above: SIT valve, below: Honeywell valves)

- [1] Gas valve - NG
- [2] Gas valve - LPG

- ▶ Re-check settings at maximum and minimum rated output and re-adjust if required.
- ▶ Seal the gas valve minimum adjustment.
- ▶ Exit the chimney sweep mode.
- ▶ Enter the CO₂ contents in the servicing record.

Adjusting the maximum rated output settings (LPG appliances)

With the appliance in maximum rated output.

- ▶ Insert the hex tool into the adjusting screw of the gas valve (as shown in the below Figure 85) and set the CO₂ content for maximum rated output.

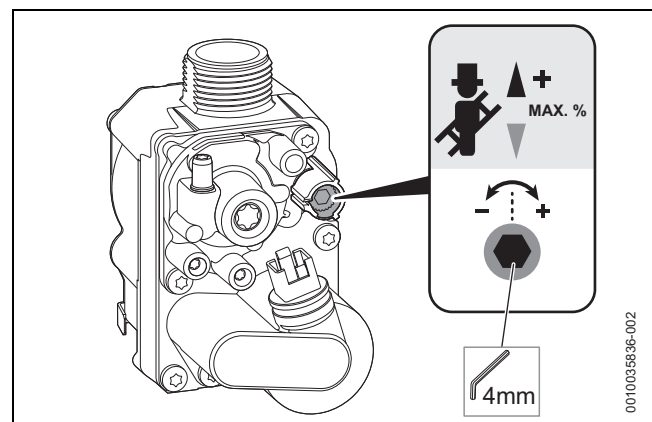

Fig. 85 Setting the CO₂ content

- ▶ Re-check settings at minimum and maximum rated output and re-adjust if required.
- ▶ Exit the chimney sweep mode.
- ▶ Enter the CO₂ contents in the servicing record.

9 Replacement parts



WARNING

Mains supplies - Isolate the appliance

- ▶ Turn off the gas supply and isolate the mains electrical supply before starting any work and observe all relevant safety precautions.
- ▶ Drain the appliance/system where necessary and protect any electrical equipment from water ingress during component replacement.



WARNING

Component replacement:

- ▶ After replacement of a gas carrying component, where a gasket or seal has been disturbed or replaced, check for gas tightness using a gas sniffer/leak detection fluid.
- ▶ On re-assembly check all affected seals for cracks, hardness and deterioration.
 - If damaged or in any doubt the seal must be replaced.
- ▶ Also after re-assembly, carry out the following checks:
 - Fan pressure.
 - Flue gas analysis.



Only use Worcester, Bosch Group original spare parts with this appliance. Non Worcester, Bosch Group original spare parts will invalidate the guarantee (if applicable) and any warranty.

- ▶ A comprehensive list of appliance spares can be found on the website www.worcester-bosch.co.uk/spares

9.1 Component access

Removing the front casing



The front casing is secured with two screws which are critical to maintain the case seal and to prevent unauthorised removal (electrical safety).

- ▶ Always secure the casing with these screws.
- ▶ Loosen the two screws [1] and pull the bottom of the casing forward.
- ▶ Lift off the casing.

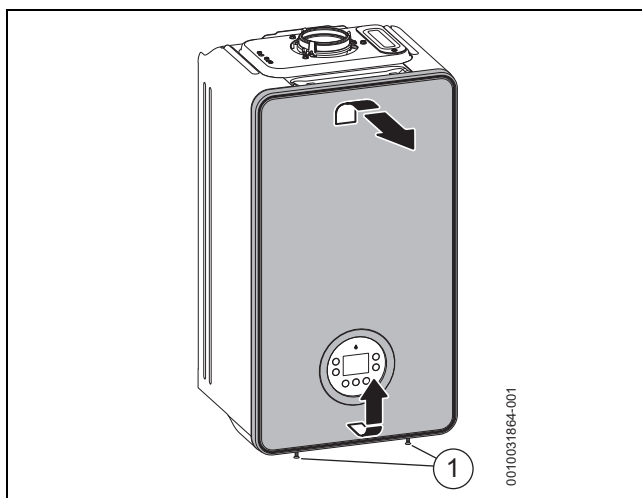

Fig. 86 Removing the front casing

9.2 Draining the appliance

NOTICE

Risk of water damage to appliance or property!

Damage from disconnecting water pathways which may have retained some water.

- ▶ Take care after draining the appliance to protect equipment/property from residual water content within components.



Many of the tasks in this section require that the appliance be isolated and drained.

- ▶ Before working on any water carrying pipework and components drain the appliance.
- ▶ Connect a suitable hose firmly to the drain point and run the hose outside to a suitable point or container.
- ▶ Turn the drain valve a ¼ turn anti-clockwise to open the drain. Turn the valve firmly clockwise to close.

9.3 Removing the heat exchanger assembly

- ▶ Remove the fan, gas hose, mixing device and burner cover as described in Chapter 8.7.1 "Checking the electrodes and cleaning the heat exchanger", page 60.

Separating components from the heat exchanger assembly.

Refer to figure 87.

- ▶ Separate components from the heat exchanger assembly in the sequence shown.
 - Release the clip.
 - Detach the flow connection.
 - Disconnect the cable from the heat exchanger temperature limiter.
 - Disconnect the in-line connector from the flow temperature sensor on the heat exchanger.
 - Disconnect the cable from the flue gas temperature limiter.
 - Remove the nut.

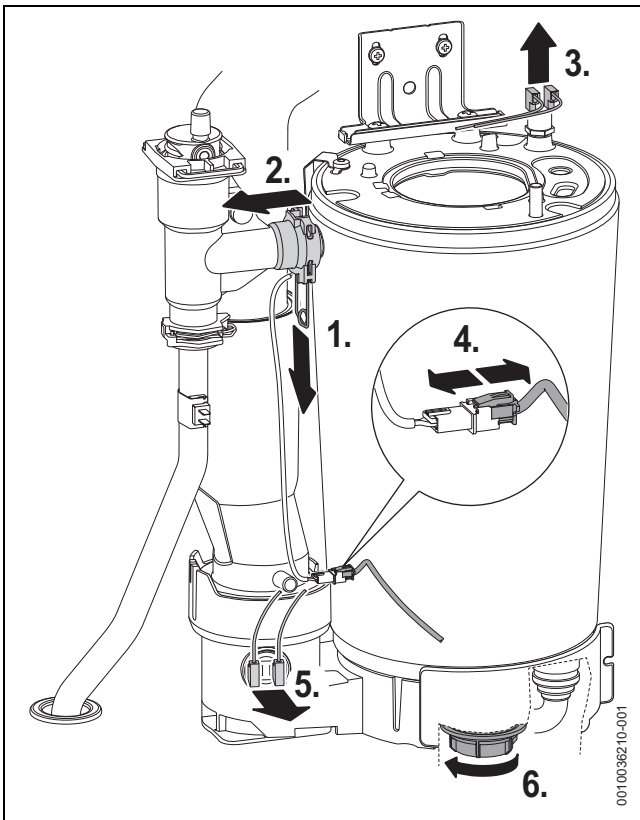

Fig. 87 Separating components from the heat exchanger assembly

Removing the heat exchanger assembly

Refer to figure 88.

- ▶ Release the flue pipe clip.
- ▶ Push the flue pipe up.
- ▶ Remove the bracket screws.

- ▶ Remove the heat exchanger assembly.

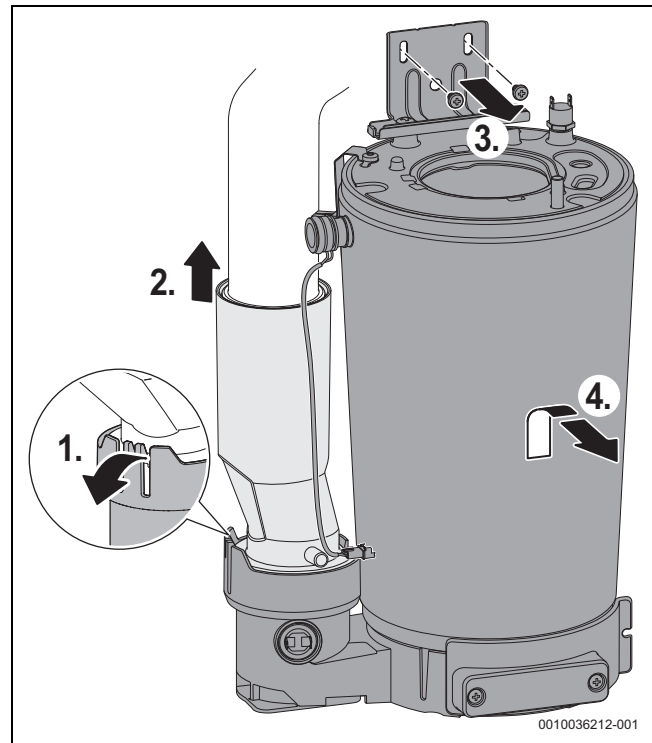

Fig. 88 Removing the heat exchanger assembly

9.4 Checking/replacing the motor of the 3-way valve (appliances fitted with diverter valve accessory)

Variant without screws

Checking 3-way valve motor.

- ▶ Carry out function check of 3-way valve motor in **Function check** menu.
 - **Service menu > Function check > Activate test** ¹⁾ > **3-way valve > Hot water.**

Detaching the motor.

- ▶ Set the 3-way valve to mid position.
 - **Service menu > Settings > Special function > 3-WV mid. pos. > Yes.**



The 3-way valve remains at the middle position for approx. 15 minutes.

- ▶ Detach the motor in the sequence shown.
 - Unplug the plug.
 - Remove the lock clip.
 - Turn the motor anti-clockwise and pull it up and out.
 - Pull the motor up to disengage from ball head and remove.

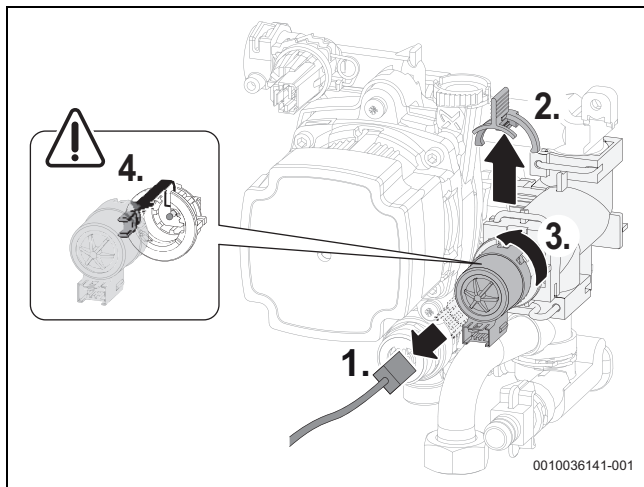

Fig. 89 Detaching the motor from the 3-way valve (variant without screws)

Installing the motor.

- ▶ Install the motor in the sequence shown.
 - Align the motor with the ball head and push down to engage.
 - Turn the motor clockwise as far as it will go.
 - Refit the lock clip.
 - Connect the plug.

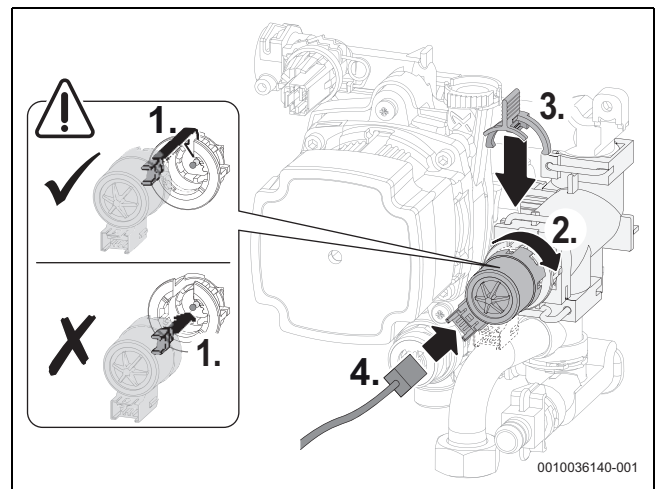

Fig. 90 Installing the motor in the 3-way valve (variant without screws)

9.5 Removing the pump

- ▶ Unplug the electrical connections [4].
- ▶ Release the ratchet connection [1] between pump and heat exchanger assembly.
- ▶ Loosen the securing screws [3].
- ▶ Remove pump assembly [2].

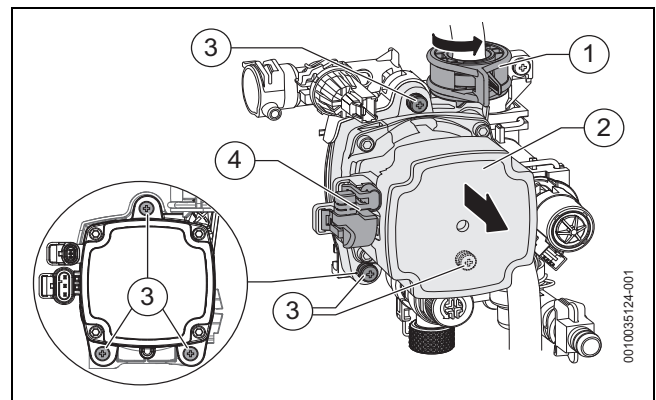

Fig. 91 Removing the pump

- ▶ Install the pump in reverse order.

1) When the Function Check menu is entered only **Burner** will be visible for the first 10 seconds, after this period of time the other components that can be tested will appear in the menu. Components such as HC1 pump, DHW circulation pump and Solar pump will show if connected to the control board.

9.6 Replacing the gas valve

- ▶ Close the gas isolator.
- ▶ Unscrew the union nut [1].
- ▶ Remove the connector [2].
- ▶ Unscrew the union nut [3].
- ▶ Remove the union nut and hose connection [4] from gas valve.
- ▶ Remove the 2 screws [6].
- ▶ Remove the gas valve [5].

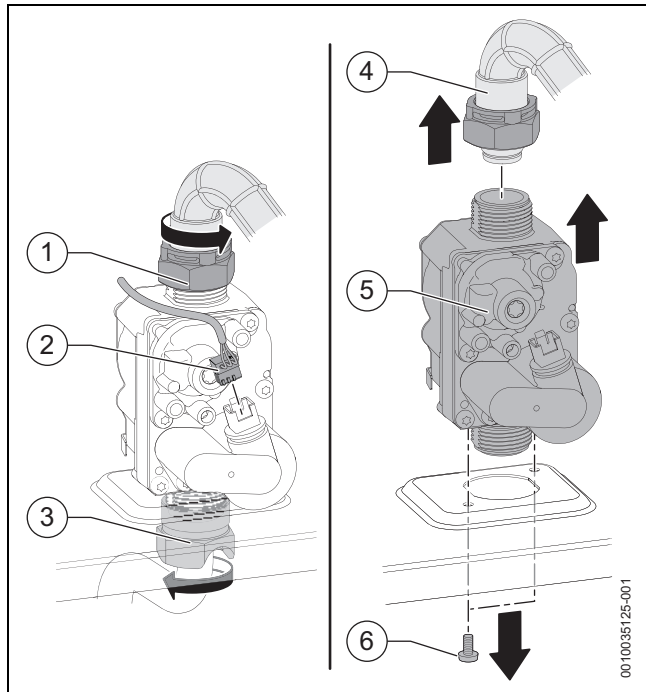

Fig. 92 Removing the gas valve

- ▶ Install the gas valve in reverse order, and check the gas/air ratio.

9.7 Replacing the expansion vessel

- ▶ Disconnect the pipe union nut [3].
- ▶ Slacken the screws on the clamps, top [1] and bottom [2] of the expansion vessel.
- ▶ Slide the expansion vessel [4] towards you to remove.

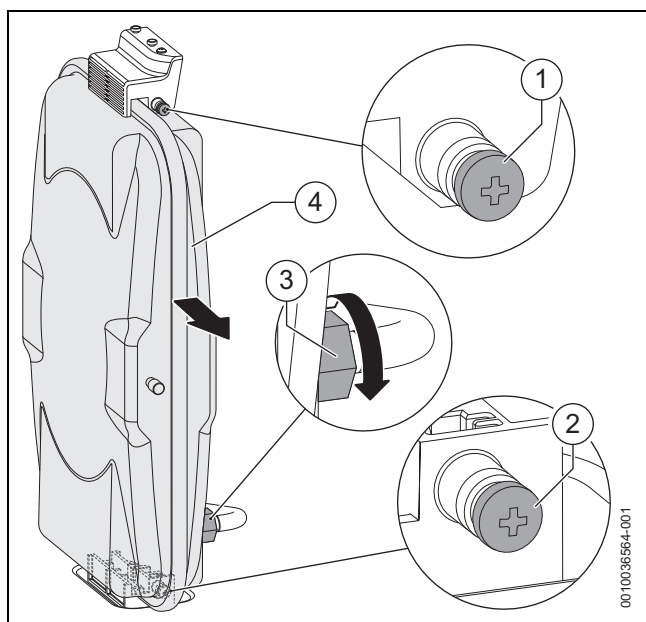

Fig. 93

- ▶ Replace the expansion vessel in the reverse order

9.8 Replacing the PRV

- ▶ Unscrew the knurled nut of the PRV discharge pipe.
- ▶ Disconnect the PRV discharge pipe prior to removing the PRV.
- ▶ Remove the PRV in the sequence shown.
 - Release the clip.
 - Pull the PRV forward to release.

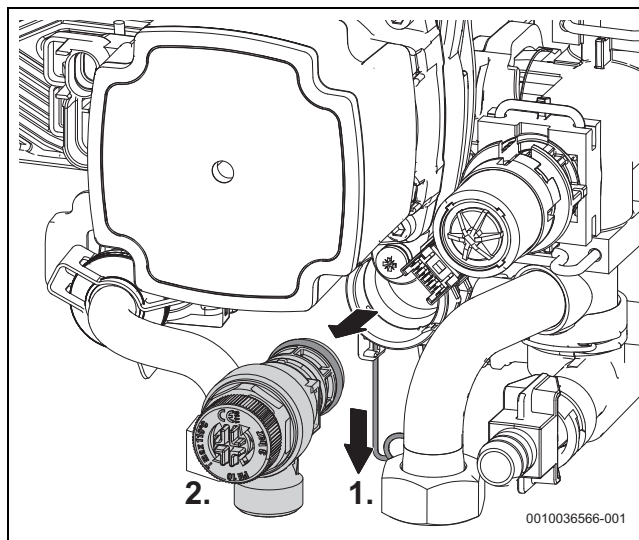

Fig. 94 PRV removal

- ▶ Replace the PRV in the reverse order

9.9 Replacing the pressure sensor



Pressure sensor is a wet pocket sensor, therefore the appliance must be drained down.

- ▶ Remove the pressure sensor in the sequence shown.
 - Release the electrical connection clip [1].
 - Disconnect the electrical connection [2].
 - Release the clip [3].
 - Pull the pressure sensor forward to release [4].

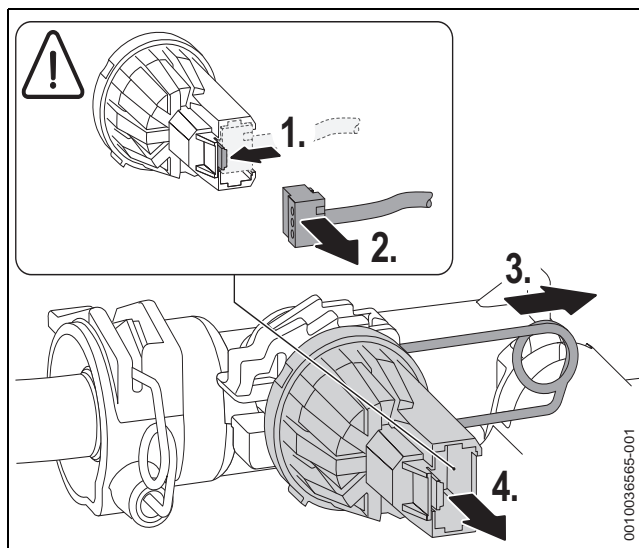

Fig. 95 Pressure sensor removal

- ▶ Replace the pressure sensor in the reverse order

9.10 Pressure gauge removal

At the rear of the boiler:

1. Release the clip securing the pressure gauge connection [1].
2. Remove the capillary from the support clip [2].
3. Pull the connection down to remove [3].

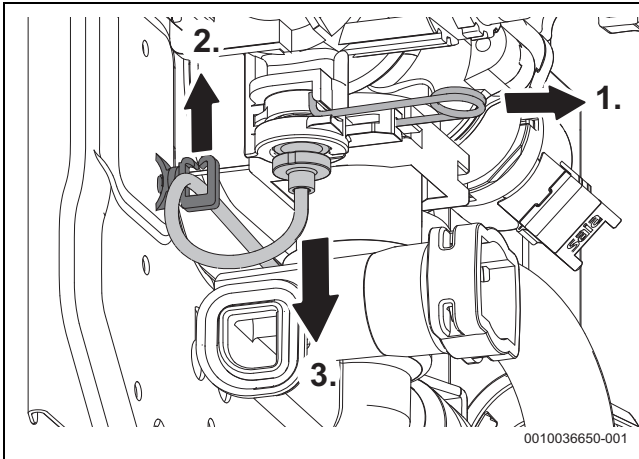

Fig. 96 Rear view of pressure gauge connection

From the front of the boiler:

1. Release at least two of the retaining clips on the pressure gauge mount.
2. Pull the pressure gauge forward and down to remove.

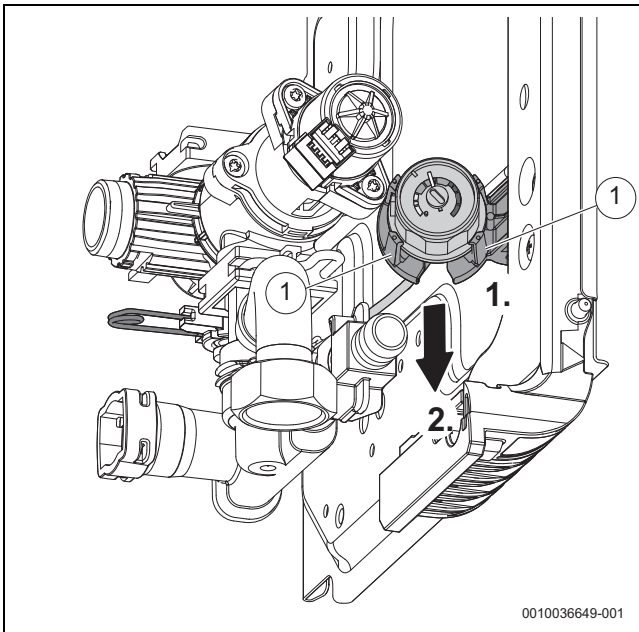

Fig. 97 Front view of pressure gauge

9.11 Replacing the control unit



Replacement control unit.

- ▶ The replacement control unit is not supplied with code plug or display cover panel. These must be removed and refitted to the replacement control unit.

Preparation before control unit removal.

- ▶ Loosen the retaining screw and open the cover.
- ▶ Remove connectors from the PCB on the both terminal strip sides.
 - Power supply (power cables) terminal strip (2).
 - Low voltage (signal cables) terminal strip (3).
- ▶ Remove connector for the Key accessory slot [4].

- ▶ Remove code plug [5].

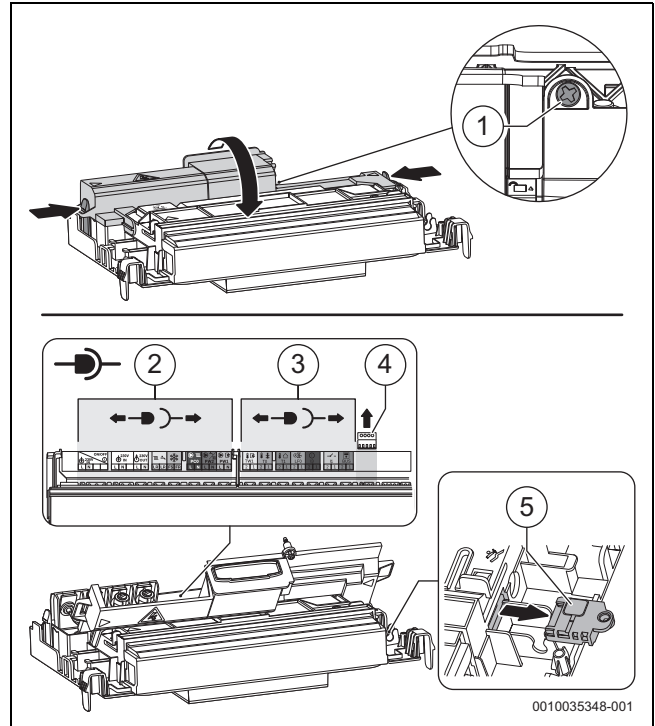

Fig. 98 Control unit removal preparations

Control unit removal.

- ▶ Release the locking latches [1] and pull the control unit [2] out of the cradle.
- ▶ Remove the display cover panel [3] from the control unit [2].
 - Lift up and forwards to release the display cover panel [3].

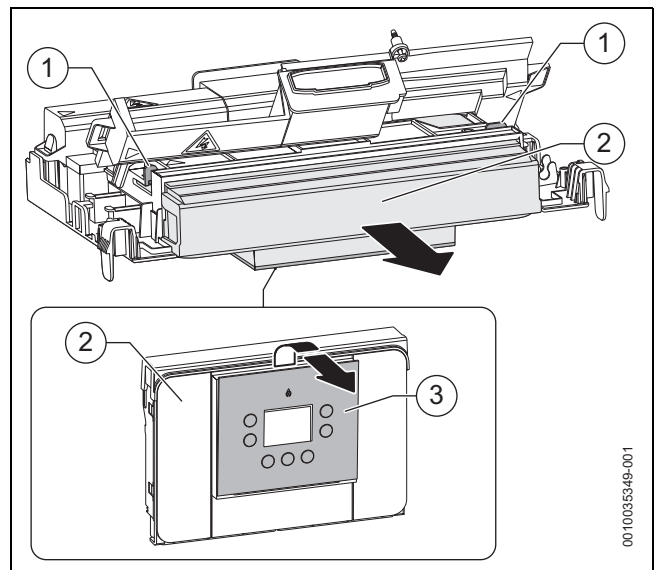

Fig. 99 Control unit removal

- ▶ Install the control panel in the reverse order.
 - Ensure all parts and connectors are fitted securely in position.

10 Fault finding and diagnosis



This fault finding information is for guidance only. Worcester cannot be held responsible for costs incurred by persons not deemed to be competent.



This fault finding system assumes that the appliance has been operating normally until the time of failure (i.e. not a first time installation error).

Basic checks

- Ensure that there is 230V power supply and the polarity is correct to the appliance.
- Ensure that the appliance settings and functionality is correct.
- Ensure the CH/DHW programmer/timer is functioning.
- Ensure the room thermostat is functioning.
- Ensure the cylinder thermostat (if fitted) is functioning.
- Ensure the cold water mains is turned on.
- Ensure the primary system has adequate pressure/system content for the system type.
- Ensure there is gas to the appliance.
 - Are other gas appliances working, gas cooker/hob for example?
 - Has the credit run out on the gas pre-payment meter?

NOTICE

On completion of the Service/Fault-Finding task which has required the breaking and remaking of electrical connections, check:

- ▶ Earth continuity,
- ▶ Short circuit check,
- ▶ Polarity,
- ▶ Resistance to earth.

10.1 Operating and fault displays

10.1.1 General information

- **Fault code:** indicates which fault is present.
- **Fault category:** indicates what kind of fault is present and its effects.

Fault category O (operating code)

Operating codes indicate the operating conditions in normal operation.

Fault category B (blocking faults)

Blocking faults result in the heating system being shut down temporarily. The heating system restarts automatically as soon as the blocking fault is removed.

Fault category V (locking faults)

Locking faults result in the heating system being shut down, and the system can only be restarted after a reset.

- ▶ Press the ▲ and ▼ keys, until **Reset** is displayed.
The appliance resumes operation.

If a fault persists:

- ▶ Rectify the fault according to 10.1.2 Fault code table

Fault category W (maintenance codes)

10.1.2 Operating/Fault code table

Fault code	Fault category	Fault text on the display, description	Remedy
200	O	Boiler in heating mode	Operating message, is not a fault. • Heating circuit is being heated.
201	O	Boiler in hot water mode	Operating message, is not a fault. • Hot water circuit is being heated.
202	O	Boiler in anti-cycle mode	Operating message, is not a fault. • Anti-cycle mode - this is the standby time between heating demands - default 5 minutes. – For example, if there is heating demand for 1 minute, the boiler will wait for 4 minutes after the heating demand before firing for a subsequent heating demand. Fault code 202 will be present during anti-cycle mode.
203	O	Boiler in standby, no heat energy demand	Operating message, is not a fault. • Appliance in standby, awaiting a demand request.
204	O	Current prim. water temp. higher than set val.	Operating message, is not a fault. • System waiting. The actual boiler water temperature is higher than the target boiler water temperature. The boiler heat demand is switched off.
208	O	Chimney sweep demand	Operating message, is not a fault. • Chimney sweep mode active.
214	V	Fan shut down during safety time	▶ Check the plug on the fan. ▶ Check the connecting lead to the fan.
224 224	B V	Maximal flue gas thermostat or heat exchanger maximal thermostat has activated Maximal flue gas thermostat or heat exchanger maximal thermostat has activated	If the blocking fault persists for a prolonged period, it becomes a locking fault. ▶ Check if the lead is disconnected from the safety temperature limiter/thermostat or the flue thermostat. ▶ Check the high limit of the safety temperature limiter/thermostat or the flue thermostat and the harness for continuity. ▶ Check the flow temperature to confirm actual temperature (may have tripped out at lower temperature, leading to a safety temperature limiter/thermostat or the flue thermostat fault). ▶ Check the system pressure and top up as required. ▶ Check if air is trapped in the system and in the boiler. ▶ Pump seized/not running: check the pump for failure or blockage. ▶ Check if a blockage/restriction within boiler/pipework is restricting the flow.
227	V	No flame signal after ignition	Tip: Check the ceramic insulator is not damaged, this can cause the spark to earth, twist and pull the ceramic insulator to ensure it is not broken. ▶ Check the gas supply to the property and the inlet on the gas valve. ▶ Check for low pressure when the gas valve opens. ▶ Gas valve failing to open: check for voltage to the valve and for possible blockage on inlet filter of the gas valve. ▶ Obstruction in the air intake to the fan leading to incorrect CO ₂ ratio. ▶ Condensate siphon is blocked or restricted. Condensate pipe is frozen. ▶ Flue is blocked or restricted. ▶ Heat exchanger is blocked or restricted. ▶ Check the burner for damage. ▶ Check the spark electrode/lead for failure. ▶ Check the flame sense/lead for failure. ▶ Check the rectification ground (black wire to heat exchanger).
228	V	Flame signal without flame present	Tip: Check the ceramic insulator is not damaged, this can cause the spark to earth, twist and pull the ceramic insulator to ensure it is not broken. ▶ Check the flame sense and the lead and replace if required. ▶ Check the earth tags on the boiler and on the electrodes. ▶ Check the operation of the siphon and that no water is collecting in the sump. ▶ Replace the gas valve. ▶ Replace the control unit and/or burner control unit.
232	B	Boiler locked by external switching contact	External cut off switch not used in UK: ▶ Ensure nothing is plugged into red I3 connection.
233	V	Boiler identification module or device electronics faulty	▶ Wrong code plug is inserted. ▶ Check the code plug is not damaged. ▶ Replace the code plug if required.

Fault code	Fault category	Fault text on the display, description	Remedy
234	V	Gas valve electrical fault	<ul style="list-style-type: none"> ▶ Check the gas supply to the property and the inlet on the gas valve (check drop on inlet). ▶ Check the connections on the gas valve and the board (loose connection). ▶ Check the continuity down harness and replace if required. ▶ Check the voltage to the gas valve (19–24 V DC approx. when demand). ▶ Check for water on the gas valve connections. ▶ Check the resistance on the gas valve (pins 1–2 approx. 69.5 Ohms). ▶ Replace the gas valve if resistances are incorrect. ▶ If all tests are correct: replace the PCB.
235	V	Conflicting versions of boiler electr. and boiler identification	<ul style="list-style-type: none"> ▶ Replace the code plug or the burner control.
237	V	System fault	<ul style="list-style-type: none"> ▶ Check the code plug is not damaged. ▶ Replace the code plug if required. ▶ Replace the control unit (PCB).
238	V	Boiler electronics faulty	<ul style="list-style-type: none"> ▶ Check the gas supply to the property and the inlet on the gas valve (check drop on inlet). ▶ Check the connections on the gas valve and the board (loose connection). ▶ Check the continuity down harness and replace if required. ▶ Check the voltage to the gas valve (19–24 V DC approx. when demand). ▶ Check for water on the gas valve connections. ▶ Check the resistance on the gas valve (pins 1–2 approx. 69.5 Ohms). ▶ If all tests are correct: replace the PCB.
242	V	Boiler electr. system fault	<ul style="list-style-type: none"> ▶ Reset appliance electronics (factory reset). ▶ Check the electrical connections on the board (check for loose wires etc.). ▶ Replace the control unit.
245	V	System fault boiler electronics / basic controller	<ul style="list-style-type: none"> ▶ Reset appliance electronics (factory reset). ▶ Check the electrical connections on the board (check for loose wires etc.). ▶ Replace the control unit.
249	V	System fault boiler electronics / basic controller	<ul style="list-style-type: none"> ▶ Reset appliance electronics (factory reset). ▶ Check the electrical connections on the board (check for loose wires etc.). ▶ Replace the control unit.
250	V	System fault boiler electronics / basic controller	<ul style="list-style-type: none"> ▶ Reset appliance electronics (factory reset). ▶ Check the electrical connections on the board (check for loose wires etc.). ▶ Replace the control unit.
251	V	System fault boiler electronics / basic controller	<ul style="list-style-type: none"> ▶ Reset appliance electronics (factory reset). ▶ Check the electrical connections on the board (check for loose wires etc.). ▶ Replace the control unit.
252	V	System fault boiler electronics / basic controller	<ul style="list-style-type: none"> ▶ Reset appliance electronics (factory reset). ▶ Check the electrical connections on the board (check for loose wires etc.). ▶ Replace the control unit.
253	V	System fault boiler electronics / basic controller	<ul style="list-style-type: none"> ▶ Reset appliance electronics (factory reset). ▶ Check the electrical connections on the board (check for loose wires etc.). ▶ Replace the control unit.
254	V	System fault boiler electronics / basic controller	<ul style="list-style-type: none"> ▶ Reset appliance electronics (factory reset). ▶ Check the electrical connections on the board (check for loose wires etc.). ▶ Replace the control unit.
258	V	System fault boiler electronics / basic controller	<ul style="list-style-type: none"> ▶ Reset appliance electronics (factory reset). ▶ Check the electrical connections on the board (check for loose wires etc.). ▶ Replace the control unit.
259	V	System fault boiler electronics / basic controller	<ul style="list-style-type: none"> ▶ Reset appliance electronics (factory reset). ▶ Check the electrical connections on the board (check for loose wires etc.). ▶ Replace the control unit.
262	V	System fault boiler electronics / basic controller	<ul style="list-style-type: none"> ▶ Reset appliance electronics (factory reset). ▶ Check the electrical connections on the board (check for loose wires etc.). ▶ Replace the control unit.

Fault code	Fault category	Fault text on the display, description	Remedy
263	V	System fault boiler electronics / basic controller	<ul style="list-style-type: none"> ▶ Reset appliance electronics (factory reset). ▶ Check the electrical connections on the board (check for loose wires etc.). ▶ Replace the control unit.
265	B	Heat demand lower than energy supplied	Operating message, is not a fault. <ul style="list-style-type: none"> • The boiler's ignition sequence alone is sufficient enough to maintain room temperature. • The modulating heat demand is higher than the minimum modulation factor of the unit. The unit switches to proportional control.
268	O	Relay test was activated	Operating message, is not a fault. <ul style="list-style-type: none"> • Appliance in component test mode.
269	V	Flame monitoring	<ul style="list-style-type: none"> ▶ Restart the appliance to see if the problem re-occurs. ▶ Check the electrical connections on the board (check for loose wires etc.). ▶ Replace the control unit (PCB).
273	B	Operation of burner and fan interrupted	Operating message, is not a fault. <ul style="list-style-type: none"> • The burner and fan have been running continuously for 24 hours and have been shut down briefly for an appliance electronic inspection
281	B	Operation of burner and fan interrupted	<ul style="list-style-type: none"> ▶ Check primary system water pressure. ▶ Check for air in the system and vent the pump. ▶ Check for circulation within heating system. ▶ Check hydraulic connections to the pump. ▶ Check wiring and operation of the pump, replace if necessary.
283	O	Burner starting	Operating message, is not a fault. <ul style="list-style-type: none"> • Burner is starting.
284	O	Opening air/gas ratio control valve/oil solenoid valves	Operating message, is not a fault. <ul style="list-style-type: none"> • Gas valve is opening.
305	O	Boiler in hot water anti-cycle mode	Operating message, is not a fault. <ul style="list-style-type: none"> • Anti-cycle mode, domestic hot water post-heat function. Following a domestic hot water demand the boiler runs for 30 seconds or until the target temperature is met. <ul style="list-style-type: none"> – Diverter valve is held in the hot water position for a period of time. – If no domestic hot water demand is requested then check for false demands on the cold water inlet.
306	V	Flame signal after closing the fuel supply	<ul style="list-style-type: none"> ▶ Check the gas valve, replace if required. ▶ Check electrodes and connecting leads, replace if required. ▶ Replace the appliance electronics.
353	O		Test non-volatile lockout Operating message, is not a fault. <ul style="list-style-type: none"> • If the boiler has been operating for 24 hours without a 20-minute off period, the boiler will not respond for a period of time whilst it undertakes diagnostics checks on the fan.
357	O	Flame signal after closing the fuel supply	Operating message, is not a fault. <ul style="list-style-type: none"> • Venting/air purge program has been automatically activated.
358	O	Anti-seizing functn. active	Operating message, is not a fault. <ul style="list-style-type: none"> • Blocking protection for the heating pump and diverter valve active. <ul style="list-style-type: none"> – The purpose of component kick is to ensure that hydraulic components such as pumps will not get stuck by giving these functional components a “kick”, i.e. they are briefly turned on after a period of inactivity. – After power up every 24 hours the appliance will do a component kick, where the pump will run for 10 seconds. – If the appliance is already in a CH or DHW heat request, these heat demands will be prioritised over component kick. But once the heat demand has ended the component kick will take place. – If this causes nuisance then please power the appliance off and on again at a more suitable time; the daily kick will then occur at the time the appliance is turned on again.
360	V	System fault boiler electronics / basic controller	<ul style="list-style-type: none"> ▶ Wrong code plug is inserted. ▶ Check the code plug is not damaged. ▶ Replace the code plug if required.
362	–	Boiler identification module or boiler electronics faulty	Is not a fault. <ul style="list-style-type: none"> • Service plug detected.

Fault code	Fault category	Fault text on the display, description	Remedy
363	V	System fault boiler electronics / basic controller	<ul style="list-style-type: none"> ▶ Check and replace the ionisation cable. ▶ Check and replace the electrodes if required. ▶ Check and replace the control unit and/or burner control unit.
810		Hot water remains cold	<ul style="list-style-type: none"> ▶ Reset the appliance and wait 24 hours ▶ Check the DHW valves, ▶ Check the 3-way valve, replace if necessary, ▶ Check that the tank is properly connected.
811	A	Hot water heating: thermal disinfection failed	<ul style="list-style-type: none"> ▶ If water is being drawn constantly, take action to stop this. ▶ Position the DHW temperature sensor correctly. ▶ Check that there is contact between the DHW cylinder temperature sensor and the cylinder. ▶ Vent the cylinder circuit. ▶ Set DHW heating to "priority". ▶ Check plate heat exchanger for calcification. ▶ Check sizing of DHW circulation line and heat loss.
1010	-	No communication via EMS BUS connection	<ul style="list-style-type: none"> ▶ Check the grey ribbon on far right of the PCB (low voltage connection). ▶ If using a Key control product check the Key connections (black, white, red, green) are plugged into the correct position on the PCB (under installer cover on the far right hand side, leaving one space to the BUS connection). ▶ Check that the Key is pushed fully home. ▶ Check the batteries of the room control. ▶ Check the bridging links are fitted at LR & 230 V out. ▶ For wired room controls check the EMS BUS Voltage to the remote control is 12 - 15V DC. ▶ Check the 230 V external wiring does not run alongside the BUS connections, thus causing interference. ▶ Replace the control unit
1013	W	Max. combustion point reached	<p>The service reminder message is present due to the maximum burner hours service threshold being reached.</p> <ul style="list-style-type: none"> ▶ Carry out maintenance. ▶ Reset the maintenance code via the reset menu.
1017	W	System pressure too low	<ul style="list-style-type: none"> ▶ Top up system water and vent the system. ▶ Check the voltage to the pressure sensor and the signal back from the pressure sensor. ▶ Replace the pressure sensor.
1018	W	Maintenance interval expired	<ul style="list-style-type: none"> ▶ Carry out maintenance. ▶ Reset the maintenance code via the reset menu.
1019	W	Incorrect pump type detected	<ul style="list-style-type: none"> ▶ Pump communication failure or wrong pump is fitted (i.e. non-ErP). ▶ Check the pump communication wire is connected and has continuity. ▶ Replace the pump for correct modulating pump.
1021	B	Cylinder charging or hot water temperature sensor faulty	<p>A 1021 error can only be cleared by powering the appliance off and back on again the hot water sensor has been changed if open or short circuit, or refitted to the pipe if it has fallen off.</p> <ul style="list-style-type: none"> ▶ Check the domestic hot water temperature sensor is connected and the harness is fitted securely to the sensor. ▶ Check the resistance of the temperature sensor and replace if required. ▶ Check the continuity of harness and replace if required.
1022	W	Cylinder temp. sensor faulty or contact problems	<ul style="list-style-type: none"> ▶ Connect the plug to the temperature sensor correctly. ▶ Connect the plug to the control device correctly. ▶ Check the temperature sensor, replace if necessary. ▶ Check temperature sensor connecting lead, replace if necessary.
1023	W	Maximum run time including standby time reached	<p>The service reminder message is present due to the maximum run time (boiler hours) being reached.</p> <ul style="list-style-type: none"> ▶ Carry out maintenance. ▶ Reset the maintenance code via the reset menu.
1037	W	Outside temp. sensor faulty - heating back-up operation active	<p>Tip: Check the weather compensation is applicable and the menu has not been accidentally switched on in the menu.</p> <ul style="list-style-type: none"> ▶ Check the positioning of the outside weather sensor. ▶ Check the weather sensor connections on the control board.

Fault code	Fault category	Fault text on the display, description	Remedy
1065	W	System pressure sensor faulty or not connected	<ul style="list-style-type: none"> ▶ Check the plug is connected correctly to the pressure sensor. ▶ Check pressure sensor connecting leads for breaks or short circuits, replace if necessary. ▶ Check the pressure sensor, replace if necessary.
1068	W	Outside temp. sensor or lambda probe faulty.	<ul style="list-style-type: none"> ▶ Check the plug to the temperature sensor, connect correctly. ▶ Check connecting lead for break or short circuit, replace if required. ▶ Check temperature sensor, replace if necessary. ▶ Check appliance electronics, replace control unit if necessary.
1070	W	Maintenance is due on <dd.mm.yyyy> please call your service engineer	Advanced service reminder warning. <ul style="list-style-type: none"> ▶ Check the maintenance menu. ▶ Reset the maintenance code via the reset menu.
1071	W	Maintenance is now due please call your service engineer	<ul style="list-style-type: none"> ▶ Check the maintenance menu. ▶ Reset the maintenance code via the reset menu.
1072	W	Maintenance is overdue please call your service engineer	<ul style="list-style-type: none"> ▶ Check the maintenance menu. ▶ Reset the maintenance code via the reset menu.
1073	W	Short-circuit at flow temp. sensor	<ul style="list-style-type: none"> ▶ Check the flow temperature sensor plug is connected. ▶ Check the resistance of the flow temperature sensor and replace if required. ▶ Check the continuity of harness and replace if required. ▶ Replace the flow temperature sensor.
1074	W	No signal from flow temperature sensor	<ul style="list-style-type: none"> ▶ Check the flow temperature sensor plug is connected. ▶ Check the resistance of the flow temperature sensor and replace if required. ▶ Check the continuity of harness and replace if required. ▶ Replace the flow temperature sensor. ▶ Replace the PCB.
1075	W	Heat exchanger temp sensor short circuit	<ul style="list-style-type: none"> ▶ Check the flow temperature sensor plug is connected. ▶ Check the resistance of the flow temperature sensor and replace if required. ▶ Check the continuity of harness and replace if required. ▶ Replace the flow temperature sensor. ▶ Replace the PCB.
1076	W	Heat exchanger temp sensor disconnected	<ul style="list-style-type: none"> ▶ Check the flow temperature sensor plug is connected. ▶ Check the resistance of the flow temperature sensor and replace if required. ▶ Check the continuity of harness and replace if required. ▶ Replace the flow temperature sensor. ▶ Replace the PCB.
2085	V	Internal fault	<ul style="list-style-type: none"> ▶ Reset the appliance. ▶ Switch off the appliance for 30 seconds and then turn back on. ▶ Check the incoming mains voltage. ▶ Check the polarity. ▶ Replace the PCB.
2908	V	System fault boiler electronics / basic controller	<ul style="list-style-type: none"> ▶ Restart the appliance to see if the problem re-occurs. ▶ If the fault remains after resetting: the burner controller (PCB) is defective and must be replaced.
2910	V	Fault in flue system	<ul style="list-style-type: none"> ▶ Check the flue for obstructions and remove any found. ▶ Check the flue integrity test. ▶ Check for water in the sump and check the siphon operation, clean if required.
2914	-	Boiler electr. system fault	<ul style="list-style-type: none"> ▶ Restart the appliance to see if the problem re-occurs. ▶ If the fault remains after resetting: the burner controller (PCB) is defective and must be replaced.
2915	V	Boiler electr. system fault	The fan keeps running after the post purge. <ul style="list-style-type: none"> ▶ Reset the appliance. ▶ Create a heat demand to test the boiler's ignition sequence. ▶ Check the voltage to the fan and the continuity of the fan harness. ▶ Check the power modulation on the fan. ▶ PCB may be defective.

Fault code	Fault category	Fault text on the display, description	Remedy
2916	V	Boiler electr. system fault	Gas valve was detected as open during post-purge. <ul style="list-style-type: none"> ▶ Carry out a gas tightness test on the gas valve and replace if required. ▶ Check the voltage to gas valve. ▶ The gas valve or the PCB may be defective
2920	V	Fault in flame monitoring	<ul style="list-style-type: none"> ▶ Check electrodes and connecting leads, replace if required. ▶ Check protective earth conductor connections (PE). ▶ Check appliance electronics, replace control unit if necessary.
2923	V	Boiler electr. system fault	Unexpected feedback from the modulating/current controlled gas valve. <ul style="list-style-type: none"> ▶ Check the voltage to the gas valve. ▶ Check the continuity of harness and replace if required. ▶ Check the resistance of the gas valve coils. ▶ The gas valve or the appliance electronics (control unit) may have a fault.
2927	B	Boiler electr. system fault	No ionisation detected after ignition. <ul style="list-style-type: none"> ▶ Check the main shut-off valve, open if necessary. ▶ Check the appliance isolation valve, open if necessary. ▶ Measure the gas supply pressure at the rated heat input. If necessary, shut down the appliance and check the gas line. ▶ Check flame sense electrode and connecting lead, replace if required. ▶ Check venturi/injector for potential blockage. ▶ Measure the ionisation current. ▶ Check the protective earth conductor connection (PE) in the control unit. ▶ Check the ignition cable for damage, replace if necessary. ▶ Check functionality of gas valve and replace if necessary. ▶ Check CO₂ settings at min and max output ▶ Check flue system. ▶ Check combustion air supply. ▶ Check the heat exchanger on the flue gas side for deposits, clean if necessary.
2928	V	Internal fault	<ul style="list-style-type: none"> ▶ Restart appliance. ▶ If the fault persists following a reset, the burner control unit is faulty and must be replaced, (replace control unit).
2931	V	System fault boiler electronics / basic controller	Illegal instruction. <ul style="list-style-type: none"> ▶ Restart appliance. ▶ If the fault persists following a reset, the burner control unit is faulty and must be replaced, (replace control unit).
2940	V	System fault burner control unit	Low voltage. <ul style="list-style-type: none"> ▶ Restart appliance. ▶ If the fault persists following a reset, the burner control unit is faulty and must be replaced, (replace control unit).
2946	V	Incorrect code plug detected	<ul style="list-style-type: none"> ▶ Check code plug, replace if necessary.
2948	B	No flame signal with low output	Burner starts automatically after purging. This can be caused by strong winds. If this fault occurs frequently: <ul style="list-style-type: none"> ▶ Check CO₂ settings. ▶ Check flue outlet position for effects of excessive wind pressure. ▶ Check flue integrity.
2949	B	No flame signal with high output	May be caused by strong winds or flue gas recirculation. The burner starts automatically after purging. <ul style="list-style-type: none"> ▶ Check the flue integrity. ▶ Check the flue terminal position. ▶ Check the CO₂ settings and adjust if necessary. ▶ Check the burner and the heat exchanger gaskets and the inner flue gaskets. ▶ Check the gas pressure during burning at full load (working pressure, dropping low).
2950	B	No flame signal following starting procedure	<ul style="list-style-type: none"> ▶ Check gas pressure whilst burning at full load. ▶ Check CO₂ settings, adjust if necessary. ▶ Check Burner and heat exchanger gaskets. ▶ Burner restarts automatically after purging.

Fault code	Fault category	Fault text on the display, description	Remedy
2951	V	Loss of flame too many times	Maximum unexpected flame losses exceeded. <ul style="list-style-type: none"> ▶ Refer to the blocking error(s) that lead to this locking error. Check the fault history on appliance. ▶ Possible incomplete purging of gas pipe. ▶ Could also indicate a wide variety of issues such as undersized pipework or gas pressure dropping off, incorrectly routed condensate discharge, incorrectly sited flues, incorrectly wired etc.
2952	V	Internal fault when testing the ionisation signal	<ul style="list-style-type: none"> ▶ Perform reset. ▶ If fault persists, replace control unit.
2957	V	Boiler electr. system fault	<ul style="list-style-type: none"> ▶ Reset appliance electronics (factory reset). ▶ Check the electrical connections on the board (check for loose wires etc.). ▶ Replace the control unit.
2961	V	No fan signal available	<ul style="list-style-type: none"> ▶ Check the mains voltage to the fan. ▶ Check the fan harness for continuity and replace if required. ▶ Check the pulse width modulation (PWM). ▶ Replace the fan. ▶ Replace the PCB.
2962	V	No fan signal available	<ul style="list-style-type: none"> ▶ Check the mains voltage to the fan. ▶ Check the fan harness for continuity and replace if required. ▶ Check the pulse width modulation (PWM). ▶ Replace the fan. ▶ Replace the PCB.
2963	B	The heat exchanger sensor or both supply and heat exchanger sensors are defect	<ul style="list-style-type: none"> ▶ Check the flow through the appliance and the system is filled. ▶ Check for air locks in the system and purge if required. ▶ Check the heat exchanger sensor (primary thermistor) and the plug connected to temperature sensor. ▶ Check the resistance of the temperature sensor and replace if required. ▶ Check the continuity of the temperature sensor harness and replace if required.
2964	B	Flow rate in heat exchanger too low	<ul style="list-style-type: none"> ▶ Check the flow through the appliance and that the system is filled. ▶ Check for air locks in the system and purge if required. ▶ Check the heat exchanger sensor (primary thermistor) and the plug connected to the temperature sensor. ▶ Check the resistance of the temperature sensor and replace if required. ▶ Check the continuity of the harness and replace if required.
2965	B	Flow temperature too high	<ul style="list-style-type: none"> ▶ System is not filled with water. ▶ No water flow, because CH system is closed. ▶ No water flow, because pump is not operating correctly. ▶ Check flow through appliance and system pressure. ▶ Check for air locks in the system. Purge if required. ▶ Check isolation valves.
2966	B	Flow temperature rise in heat exchanger too rapid	<ul style="list-style-type: none"> ▶ System is not filled with water. ▶ No water flow, because CH system is closed. ▶ No water flow, because pump is not operating correctly. ▶ Check pump is operating freely check voltage to pump. ▶ Check the isolation valves. ▶ Check for air locks in the system, purge if required. ▶ Check flow through appliance and system pressure.
2967	B	The temperature difference between supply temperature sensor and temperature sensor at heat exchanger is too large	<ul style="list-style-type: none"> ▶ Check the flow through the appliance and that the system is filled. ▶ Check for air locks in the system and purge if required. ▶ Check the isolation valves, ensure they are open. ▶ Check the pump is operating freely and check the voltage to the pump. ▶ Check the heat exchanger sensor and the flow sensor are making correct contact with the heat exchanger assembly/pipework. ▶ Check the heat exchanger sensor for break or short circuit, replace if required. ▶ Check the resistance of the supply sensor for break or short circuit, replace if required. ▶ Check the continuity of harness, replace if required.

Fault code	Fault category	Fault text on the display, description	Remedy
2970	B	Pressure drop in heating system too rapid	Too many unexpected pressure drops within a short time period. Cause code can appear if system is pressurised and the system then vented. <ul style="list-style-type: none"> ▶ Re-pressurise manually and vent the system. ▶ Ensure the correct pressure. If cause code does not clear, power off appliance.
2971	B	System pressure too low	System pressure is very or extremely low. This is triggered when the pressure falls to between 0.6 and 0.3 bar. Top up water until the target pressure is reached. Filling loop <ul style="list-style-type: none"> ▶ Vent the heating system and top up water until the pre-set pressure reached. Pressure sensor <ul style="list-style-type: none"> ▶ Check the continuity down harness for the pressure sensor and replace if required. ▶ Check the voltage at the pressure sensor and replace if required.
2972	V	Mains voltage too low	<ul style="list-style-type: none"> ▶ Establish supply voltage of at least 196 VAC. ▶ Replace control unit.
3071	-		Comfort + II RF <ul style="list-style-type: none"> ▶ Check the configuration (address setting). The selected setting requires a hard-wired room control. ▶ Check the EMS connection cable of the room control for damage. The BUS voltage on the room control must be between 12 and 15 V DC. ▶ Disconnect the EMS-BUS connection to the control unit and power the boiler off and back on again. Reconnect the EMS-BUS connection. ▶ If the problem persists the room control may be defective.

Table 31 Indicators and fault displays

10.1.3 Faults that are not displayed

Appliance faults	Remedy
Combustion noises too loud; rumbling noises	<ul style="list-style-type: none"> ▶ Check the gas type. ▶ Check the gas supply pressure. ▶ Check the flue system; clean or repair if required. ▶ Check the gas/air ratio. ▶ Check the gas valve; replace if required.
Flow noises	<ul style="list-style-type: none"> ▶ Set the pump rate or pump characteristic map correctly and match to the maximum output.
Heat-up takes too long.	<ul style="list-style-type: none"> ▶ Set the pump rate or pump characteristic map correctly and match to the maximum output.
Flue gas values incorrect; CO content too high.	<ul style="list-style-type: none"> ▶ Check the gas type. ▶ Check the gas supply pressure. ▶ Check the flue system; clean, repair or replace if required. ▶ Check the gas/air ratio. ▶ Check the gas valve; replace if required.
Delayed ignition, poor ignition.	<ul style="list-style-type: none"> ▶ Check the ignition transformer function for misfiring in the Function check menu Ignition test, replace if required. ▶ Check the gas type. ▶ Check the gas supply pressure. ▶ Check the power supply. ▶ Check the electrodes with cable; replace if required. ▶ Check the flue system; clean or repair if required. ▶ Check the gas/air ratio. ▶ For natural gas: check the external gas flow monitor, replace if required. ▶ Check the burner, replace if required. ▶ Check the air/gas ratio control valve; replace if required.
Condensate in air box	<ul style="list-style-type: none"> ▶ Check the non-return valve in the burner hood assembly, replace if required.
System boilers: hot water outlet temperature is too low.	<ul style="list-style-type: none"> ▶ Check the cylinder temperature setpoint.
System boilers: no hot water.	<ul style="list-style-type: none"> ▶ Check the external controls function; replace if required.
No function, the display remains dark.	<ul style="list-style-type: none"> ▶ Check the electrical wiring for damage. ▶ Replace defective cables. ▶ Check the fuse, replace if required. One spare fuse is supplied.

Table 32 Faults that are not shown on the display

System gassing**WARNING**

If you suspect the heating system is gassing, you must exercise caution when carrying out testing or remedial work as the gasses produced can be flammable.

Do not vent air from radiators whilst the central heating is switched on. Allow 30mins after venting the radiators before using the central heating or hot water.

- ▶ Whilst venting radiators, do not allow the pressure on the boiler to drop below the point at which it is normally set.
- ▶ If the system is to be drained, the boiler must be electrically isolated.

**CAUTION**

If system pressure is repeatedly increasing, even when the appliance is not operating, you should first check that the filling link is fully closed and confirm that it is not passing. If radiators are also not heating to the top of the panels and repeatedly need venting, the heating system may be suffering from gassing. This is an indication that corrosion is taking place and requires the system being cleaned and treated to BS7593:2019.

- ▶ This should be confirmed by taking water samples to check pH levels and turbidity.
- ▶ Failure to properly maintain the heating system may result in damage to the system and appliance, and may affect the boiler warranty.

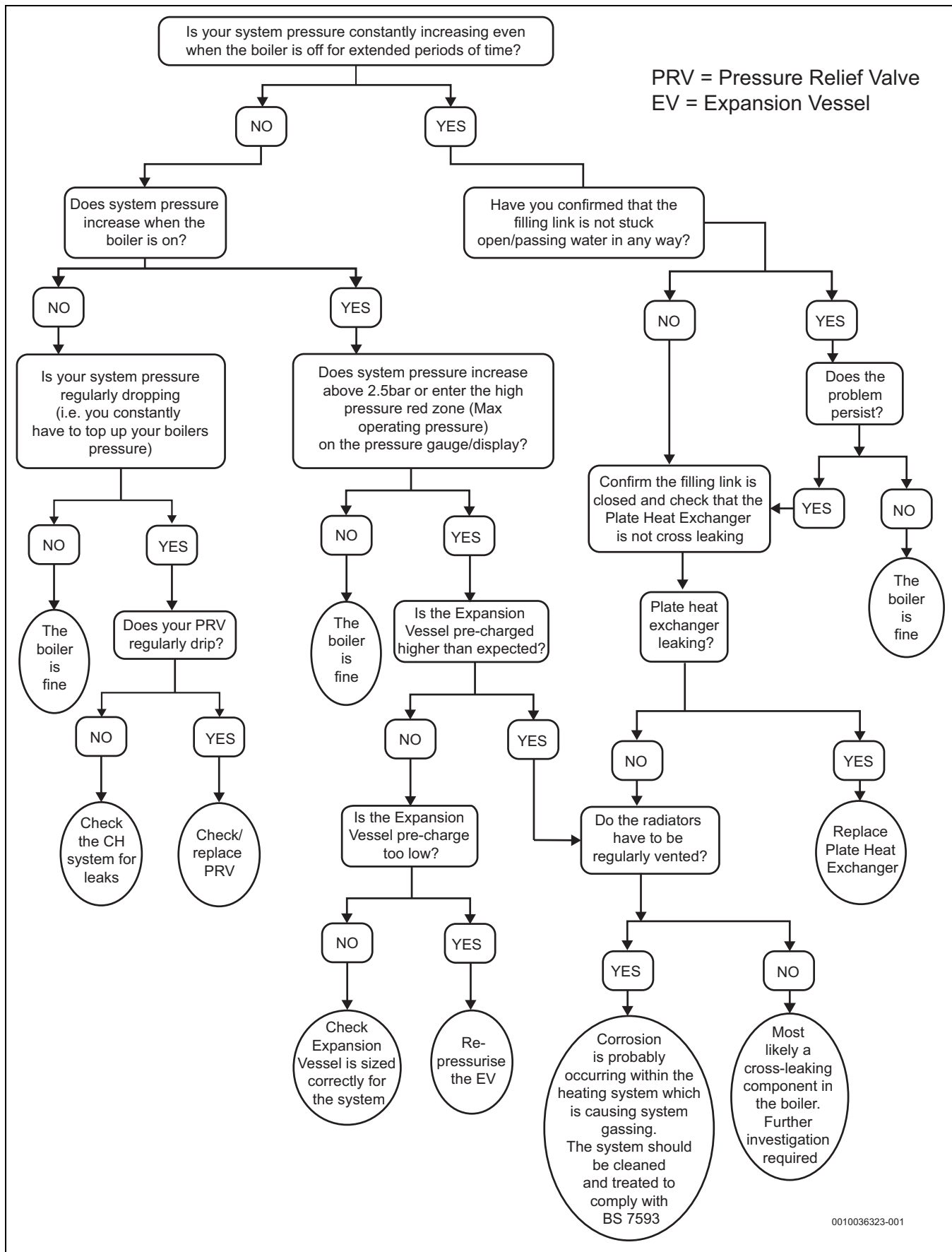

Fig. 100 System gassing flow chart

11 Environmental protection and disposal

Environmental protection is a fundamental corporate strategy of the Bosch Group.

The quality of our products, their economy and environmental safety are all of equal importance to us and all environmental protection legislation and regulations are strictly observed.

We use the best possible technology and materials for protecting the environment taking account of economic considerations.

Packaging

Where packaging is concerned, we participate in country-specific recycling processes that ensure optimum recycling.

Compostable packaging

Compostable packaging is used wherever possible in an effort to reduce the product's impact on the environment and the overall demand for plastic packaging. Where the following symbol is shown the material is compostable:



Compostable packaging can be disposed of in a number of ways:

- Home compost heap
- Local Authority garden waste collection
- Local Authority food waste collection, ideally as a food waste bin bag
- Local Authority household waste

Please note that compostable materials **cannot be recycled**.



Used appliances

Used appliances contain valuable materials that can be recycled.

The various assemblies can be easily dismantled. Synthetic materials are marked accordingly. Assemblies can therefore be sorted by composition and passed on for recycling or disposal.

Old electrical and electronic appliances



This symbol means that the product must not be disposed of with other waste, and instead must be taken to the waste collection points for treatment, collection, recycling and disposal.

The symbol is valid in countries where waste electrical and electronic equipment regulations apply, e.g. "European Directive 2012/19/EC on old electronic and electrical appliances". These regulations define the framework for the return and recycling of old electronic appliances that apply in each country.

As electronic devices may contain hazardous substances, it needs to be recycled responsibly in order to minimize any potential harm to the environment and human health. Furthermore, recycling of electronic scrap helps preserve natural resources.

For additional information on the environmentally compatible disposal of old electrical and electronic appliances, please contact the relevant local authorities, your household waste disposal service or the retailer where you purchased the product.

You can find more information here:

www.weee.bosch-thermotechnology.com/

Batteries

Batteries must not be disposed together with your household waste.

Used batteries must be disposed of in local collection systems.

12 Data Protection Notice



We, **Bosch Thermotechnology Ltd., Cotswold Way, Warndon, Worcester WR4 9SW, United Kingdom**

process product and installation information, technical and connection data, communication data, product registration and client history data to provide product functionality (art. 6 (1) sentence 1 (b)

GDPR), to fulfil our duty of product surveillance and for product safety and security reasons (art. 6 (1) sentence 1 (f) GDPR), to safeguard our rights in connection with warranty and product registration questions (art. 6 (1) sentence 1 (f) GDPR) and to analyze the distribution of our products and to provide individualized information and offers related to the product (art. 6 (1) sentence 1 (f) GDPR). To provide services such as sales and marketing services, contract management, payment handling, programming, data hosting and hotline services we can commission and transfer data to external service providers and/or Bosch affiliated enterprises. In some cases, but only if appropriate data protection is ensured, personal data might be transferred to recipients located outside of the European Economic Area. Further information are provided on request. You can contact our Data Protection Officer under: Data Protection Officer, Information Security and Privacy (C/ISP), Robert Bosch GmbH, Postfach 30 02 20, 70442 Stuttgart, GERMANY.

You have the right to object, on grounds relating to your particular situation or where personal data are processed for direct marketing purposes, at any time to processing of your personal data which is based on art. 6 (1) sentence 1 (f) GDPR. To exercise your rights, please contact us via privacy.ttgb@bosch.com To find further information, please follow the QR-Code.

13 Technical Specifications/Logs

13.1 Technical data

Technical data table - Greenstar 4000

Greenstar 4000 Description	Unit	GR4700iW 24 S		GR4700iW 21 S		GR4700iW 18 S	
		NG	LPG	NG	LPG	NG	LPG
Gas flow maximum rate - 10 minutes from lighting							
Gas inlet pressure (nominal) ¹⁾	mbar	20.0	37.0	20.0	37.0	20.0	37.0
Natural gas ²⁾	m ³ /h	2.61	-	2.28	-	1.95	-
Propane Gas (LPG) ³⁾	kg/h	-	1.91	-	1.68	-	1.43
Heat output/load							
Modulation range, heat input Q	kW	3.2 - 24.6	3.2 - 24.6	3.2 - 21.4	3.2 - 21.4	3.2 - 18.4	3.2 - 18.4
Rated heat input, DHW (net) (Q _{nW})	kW	24.6	24.6	21.4	21.4	18.4	18.4
Adjustment range, rated heat input of heating Q _n	kW	3.2 - 24.6	3.2 - 24.6	3.2 - 21.4	3.2 - 21.4	3.2 - 18.4	3.2 - 18.4
Adjustment range, rated heat output (80/60 °C) P _n	kW	3.0 - 24.0	3.0 - 24.0	3.0 - 21.0	3.0 - 21.0	3.0 - 18.0	3.0 - 18.0
Adjustment range, rated heat output (50/30 °C) P _{cond}	kW	3.3 - 24.8	3.3 - 24.8	3.3 - 21.9	3.3 - 21.9	3.3 - 18.8	3.3 - 18.8
Adjustment range, rated heat output (40/30 °C)	kW	3.3 - 24.8	3.3 - 24.8	3.3 - 21.9	3.3 - 21.9	3.3 - 18.9	3.3 - 18.9
Maximum flow temperature	°C	82	82	82	82	82	82
Maximum flow temperature possible	°C	86	86	86	86	86	86
Maximum permissible operating pressure (PMS)	bar (MPa)	2.5 (0.25)	2.5 (0.25)	2.5 (0.25)	2.5 (0.25)	2.5 (0.25)	2.5 (0.25)
Available pump head at 20 °C system temperature rise	m	2	2	2	2	2	2
Flue							
Flue gas temperature 80/60 °C, rated/min. load	°C	71/57	71/57	68/57	68/57	65/57	65/57
Flue gas temperature 40/30 °C, rated/min. load	°C	50/30	50/30	47/30	47/30	45/30	45/30
CO ₂ level at max. rated heat output (after 10 minutes)	%	9.4	10.8	9.4	10.8	9.4	10.8
CO ₂ level at min. rated heat output (after 10 minutes)	%	8.6	10.2	8.6	10.2	8.6	10.2
NOx rating (EN 15502-1)	mg/kWh	40	49	35	47	37	54
NOx Class	-	6	6	6	6	6	6
Condensate							
Maximum condensate rate	l/h	2	2	1.8	1.8	1.5	1.5
pH value, approx.	-	4.8	4.8	4.8	4.8	4.8	4.8
Electrical							
Electrical power supply voltage	a.c. V	230	230	230	230	230	230
Frequency	Hz	50	50	50	50	50	50
Maximum power consumption (stand-by)	W	2	2	2	2	2	2
Maximum power consumption (heating)	W	94	94	83	83	73	73
Maximum power consumption (Domestic Hot Water)	W	94	94	83	83	73	73
Energy efficiency index (EEI) heating pump	-	≤ 0.20	≤ 0.20	≤ 0.20	≤ 0.20	≤ 0.20	≤ 0.20
Approval data							
Gas group classification (gas type) UK/IE				CATII _{2H/3P}			
Installation type				C ₁₃ , C ₃₃ , C ₅₃			
General data							
Expansion vessel capacity	l	6	6	6	6	6	6
Expansion vessel pre-charge pressure	bar	0.75	0.75	0.75	0.75	0.75	0.75
Appliance protection rating	IP	X4D	X4D	X4D	X4D	X4D	X4D
Permissible ambient temperature	°C	0-50	0-50	0-50	0-50	0-50	0-50
Nominal capacity of the appliance	l	3.9	3.9	3.9	3.9	3.9	3.9
Total packaged weight	kg	39.3	39.3	39.3	39.3	39.3	39.3
Total appliance weight (excluding packaging)	kg	33.2	33.2	33.2	33.2	33.2	33.2
Lift weight (front panel removed)	kg	30.6	30.6	30.6	30.6	30.6	30.6
Lift weight (front panel and expansion vessel removed)	kg	26.7	26.7	26.7	26.7	26.7	26.7
SEDBUK 2009/12	%	89.4	90.5	89.6	90.6	89.6	90.6
SEDBUK 2005	%	90.2	91.9	90.2	92.0	90.3	92.0

1) For minimum and maximum permissible pressure refer to "Gas pressure within the system", section 6.5.

2) The Gas Rate provided assumes the accepted NG averaged calorific value of 34.9 MJ/m³ net.

3) Propane/butane mixture for fixed containers with capacity up to 15 000 litres.

Table 33 Technical data Greenstar 4000

Greenstar 4000 Description	Unit	GR4700iW 15 S		GR4700iW 12 S	
		NG	LPG	NG	LPG
Gas flow maximum rate - 10 minutes from lighting					
Gas inlet pressure (nominal) ¹⁾	mbar	20.0	37.0	20.0	37.0
Natural gas ²⁾	m ³ /h	1.63	-	1.30	-
Propane Gas (LPG) ³⁾	kg/h	-	1.19	-	0.95
Heat output/load					
Modulation range, heat input Q	kW	2.0 - 15.3	2.0 - 15.3	2.0 - 12.2	2.0 - 12.2
Rated heat input, DHW (net) (Q _{nW})	kW	15.3	15.3	12.2	12.2
Adjustment range, rated heat input of heating Q _n	kW	2.0 - 15.3	2.0 - 15.3	2.0 - 12.2	2.0 - 12.2
Adjustment range, rated heat output (80/60 °C) P _n	kW	1.9 - 15.0	1.9 - 15.0	1.9 - 12.0	1.9 - 12.0
Adjustment range, rated heat output (50/30 °C) P _{cond}	kW	2.1 - 15.8	2.1 - 15.8	2.1 - 12.8	2.1 - 12.8
Adjustment range, rated heat output (40/30 °C)	kW	2.1 - 15.9	2.1 - 15.9	2.1 - 12.8	2.1 - 12.8
Maximum flow temperature	°C	82	82	82	82
Maximum flow temperature possible	°C	86	86	86	86
Maximum permissible operating pressure (PMS)	bar (MPa)	2.5 (0.25)	2.5 (0.25)	2.5 (0.25)	2.5 (0.25)
Available pump head at 20 °C system temperature rise	m	2	2	2	2
Flue					
Flue gas temperature 80/60 °C, rated/min. load	°C	63/57	63/57	62/57	62/57
Flue gas temperature 40/30 °C, rated/min. load	°C	41/30	41/30	38/30	38/30
CO ₂ level at max. rated heat output (after 10 minutes)	%	9.4	10.8	9.4	10.8
CO ₂ level at min. rated heat output (after 10 minutes)	%	8.6	10.2	8.6	10.2
NOx rating (EN 15502-1)	mg/kWh	34	47	31	46
NOx Class	-	6	6	6	6
Condensate					
Maximum condensate rate	l/h	1.2	1.2	0.9	0.9
pH value, approx.	-	4.8	4.8	4.8	4.8
Electrical					
Electrical power supply voltage	a.c. V	230	230	230	230
Frequency	Hz	50	50	50	50
Maximum power consumption (stand-by)	W	2	2	2	2
Maximum power consumption (heating)	W	75	75	63	63
Maximum power consumption (Domestic Hot Water)	W	75	75	63	63
Energy efficiency index (EEI) heating pump	-	≤ 0.20	≤ 0.20	≤ 0.20	≤ 0.20
Approval data					
Gas group classification (gas type) UK/IE				CATII _{2H/3P}	
Installation type				C ₁₃ , C ₃₃ , C ₅₃	
General data					
Expansion vessel capacity	l	6	6	6	6
Expansion vessel pre-charge pressure	bar	0.75	0.75	0.75	0.75
Appliance protection rating	IP	X4D	X4D	X4D	X4D
Permissible ambient temperature	°C	0-50	0-50	0-50	0-50
Nominal capacity of the appliance	l	3.9	3.9	3.9	3.9
Total packaged weight	kg	39.3	39.3	39.3	39.3
Total appliance weight (excluding packaging)	kg	33.2	33.2	33.2	33.2
Lift weight (front panel removed)	kg	30.6	30.6	30.6	30.6
Lift weight (front panel and expansion vessel removed)	kg	26.7	26.7	26.7	26.7
SEDBUK 2009/12	%	89.7	90.5	89.8	90.7
SEDBUK 2005	%	90.4	92.1	90.5	92.1

1) For minimum and maximum permissible pressure refer to "Gas pressure within the system", section 6.5.

2) The Gas Rate provided assumes the accepted NG averaged calorific value of 34.9 MJ/m³ net.

3) Propane/butane mixture for fixed containers with capacity up to 15 000 litres.

Table 34 Technical data Greenstar 4000

13.2 Energy consumption

13.2.1 Product data on energy consumption

Natural Gas appliance

The following product data comply with the requirements of the EU Regulations No. 811/2013, No. 812/2013, No. 813/2013 and No. 814/2013 supplementing the Regulation (EU) 2017/1369.

Product data	Symbol	Unit	7 733 600 385	7 733 600 383	7 733 600 381
Product type	–	–	GR4700iW 24 S NG	GR4700iW 21 S NG	GR4700iW 18 S NG
Condensing boiler	–	–	✓	✓	✓
Low temperature boiler	–	–	✗	✗	✗
B1 boiler	–	–	✗	✗	✗
Cogeneration space heater	–	–	✗	✗	✗
Equipped with a supplementary heater?	–	–	–	–	–
Combination heater	–	–	✗	✗	✗
Rated heat output	P_{rated}	kW	24	21	18
Seasonal space heating energy efficiency	η_s	%	94	94	94
Energy Efficiency Class	–	–	A	A	A
Useful heat output					
At rated heat output and high temperature regime ¹⁾	P_4	kW	24	21	18
At 30 % of rated heat output and low temperature regime ²⁾	P_1	kW	8.1	7.1	6.1
Useful efficiency					
At rated heat output and high temperature regime ¹⁾	η_4	%	87.9	88.2	88.1
At 30 % of rated heat output and low temperature regime ²⁾	η_1	%	98.9	99	99.1
Auxiliary electricity consumption					
At full load	e_{max}	kW	0.038	0.030	0.027
At part load	e_{min}	kW	0.012	0.011	0.011
In standby mode	P_{SB}	kW	0.002	0.002	0.002
Other items					
Standby heat loss	P_{stby}	kW	0.059	0.059	0.059
Ignition burner power consumption	P_{ign}	kW	–	–	–
Emissions of nitrogen oxides (only gas- or oil fired)	NO_x	mg/kWh	40	35	37
Annual energy consumption	Q_{HE}	kWh	20556	18056	15287
Annual energy consumption	Q_{HE}	GJ	74	65	55
Sound power level, indoors	L_{WA}	dB	45	44	45

1) High-temperature regime means 60 °C return temperature at heater inlet and 80 °C feed temperature at heater outlet.

2) Low temperature means for condensing boilers 30 °C, for low-temperature boilers 37 °C and for other heaters 50 °C return temperature (at heater inlet).

Table 35 Product data on energy consumption Greenstar 4000

The following product data comply with the requirements of the EU Regulations No. 811/2013, No. 812/2013, No. 813/2013 and No. 814/2013 supplementing the Regulation (EU) 2017/1369.

Product data	Symbol	Unit	7 733 600 379	7 733 600 377
Product type	–	–	GR4700iW 15 S NG	GR4700iW 12 S NG
Condensing boiler	–	–	✓	✓
Low temperature boiler	–	–	✗	✗
B1 boiler	–	–	✗	✗
Cogeneration space heater	–	–	✗	✗
Equipped with a supplementary heater?	–	–	–	–
Combination heater	–	–	✗	✗
Rated heat output	P_{rated}	kW	15	12
Seasonal space heating energy efficiency	η_s	%	94	94
Energy Efficiency Class	–	–	A	A
Useful heat output				
At rated heat output and high temperature regime ¹⁾	P_4	kW	15	12
At 30 % of rated heat output and low temperature regime ²⁾	P_1	kW	5.1	4.0
Useful efficiency				
At rated heat output and high temperature regime ¹⁾	η_4	%	88.4	88.5
At 30 % of rated heat output and low temperature regime ²⁾	η_1	%	99.2	99.5
Auxiliary electricity consumption				
At full load	e_{max}	kW	0.031	0.023
At part load	e_{min}	kW	0.011	0.011
In standby mode	P_{SB}	kW	0.002	0.002
Other items				
Standby heat loss	P_{stby}	kW	0.059	0.059
Ignition burner power consumption	P_{ign}	kW	–	–
Emissions of nitrogen oxides (only gas- or oil fired)	NO_x	mg/kWh	34	31
Annual energy consumption	Q_{HE}	kWh	12778	10278
Annual energy consumption	Q_{HE}	GJ	46	37
Sound power level, indoors	L_{WA}	dB	43	42

1) High-temperature regime means 60 °C return temperature at heater inlet and 80 °C feed temperature at heater outlet.

2) Low temperature means for condensing boilers 30 °C, for low-temperature boilers 37 °C and for other heaters 50 °C return temperature (at heater inlet).

Table 36 Product data on energy consumption Greenstar 4000

LPG appliances

The following product data comply with the requirements of the EU Regulations No. 811/2013, No. 812/2013, No. 813/2013 and No. 814/2013 supplementing the Regulation (EU) 2017/1369.

Product data	Symbol	Unit	7 733 600 386	7 733 600 384	7 733 600 382
Product type	–	–	GR4700iW 24 S LPG	GR4700iW 21 S LPG	GR4700iW 18 S LPG
Condensing boiler	–	–	✓	✓	✓
Low temperature boiler	–	–	✗	✗	✗
B1 boiler	–	–	✗	✗	✗
Cogeneration space heater	–	–	✗	✗	✗
Equipped with a supplementary heater?	–	–	–	–	–
Combination heater	–	–	✗	✗	✗
Rated heat output	P_{rated}	kW	24	21	18
Seasonal space heating energy efficiency	η_s	%	94	94	94
Energy Efficiency Class	–	–	A	A	A
Useful heat output					
At rated heat output and high temperature regime ¹⁾	P_4	kW	24	21	18
At 30 % of rated heat output and low temperature regime ²⁾	P_1	kW	8.1	7.1	6.1
Useful efficiency					
At rated heat output and high temperature regime ¹⁾	η_4	%	87.9	88.2	88.1
At 30 % of rated heat output and low temperature regime ²⁾	η_1	%	98.9	99	99.1
Auxiliary electricity consumption					
At full load	$e_{\text{I,max}}$	kW	0.038	0.030	0.027
At part load	$e_{\text{I,min}}$	kW	0.012	0.011	0.011
In standby mode	P_{SB}	kW	0.002	0.002	0.002
Other items					
Standby heat loss	P_{stby}	kW	0.059	0.059	0.059
Ignition burner power consumption	P_{ign}	kW	–	–	–
Emissions of nitrogen oxides (only gas- or oil fired)	NO_x	mg/kWh	40	35	37
Annual energy consumption	Q_{HE}	kWh	20556	18056	15287
Annual energy consumption	Q_{HE}	GJ	74	65	55
Sound power level, indoors	L_{WA}	dB	45	44	45

1) High-temperature regime means 60 °C return temperature at heater inlet and 80 °C feed temperature at heater outlet.

2) Low temperature means for condensing boilers 30 °C, for low-temperature boilers 37 °C and for other heaters 50 °C return temperature (at heater inlet).

Table 37 Product data on energy consumption Greenstar 4000

The following product data comply with the requirements of the EU Regulations No. 811/2013, No. 812/2013, No. 813/2013 and No. 814/2013 supplementing the Regulation (EU) 2017/1369.

Product data	Symbol	Unit	7 733 600 380	7 733 600 378
Product type	–	–	GR4700iW 15 S LPG	GR4700iW 12 S LPG
Condensing boiler	–	–	✓	✓
Low temperature boiler	–	–	✗	✗
B1 boiler	–	–	✗	✗
Cogeneration space heater	–	–	✗	✗
Equipped with a supplementary heater?	–	–	–	–
Combination heater	–	–	✗	✗
Rated heat output	P_{rated}	kW	15	12
Seasonal space heating energy efficiency	η_s	%	94	94
Energy Efficiency Class	–	–	A	A
Useful heat output				
At rated heat output and high temperature regime ¹⁾	P_4	kW	15	12
At 30 % of rated heat output and low temperature regime ²⁾	P_1	kW	5.1	4.0
Useful efficiency				
At rated heat output and high temperature regime ¹⁾	η_4	%	88.4	88.5
At 30 % of rated heat output and low temperature regime ²⁾	η_1	%	99.2	99.5
Auxiliary electricity consumption				
At full load	e_{max}	kW	0.031	0.023
At part load	e_{min}	kW	0.011	0.011
In standby mode	P_{SB}	kW	0.002	0.002
Other items				
Standby heat loss	P_{stby}	kW	0.059	0.059
Ignition burner power consumption	P_{ign}	kW	–	–
Emissions of nitrogen oxides (only gas- or oil fired)	NO_x	mg/kWh	34	31
Annual energy consumption	Q_{HE}	kWh	12778	10278
Annual energy consumption	Q_{HE}	GJ	46	37
Sound power level, indoors	L_{WA}	dB	43	42

1) High-temperature regime means 60 °C return temperature at heater inlet and 80 °C feed temperature at heater outlet.

2) Low temperature means for condensing boilers 30 °C, for low-temperature boilers 37 °C and for other heaters 50 °C return temperature (at heater inlet).

Table 38 Product data on energy consumption Greenstar 4000

13.3 Component resistance characteristics



The supply sensors (flow temperature sensor at heat exchanger assembly and flow temperature sensor at flow pipe) share the same resistance values.

► Refer to table 39.

13.3.1 Sensor values - Flow temperature sensor

Temperature [°C ± 10 %]	Resistance [Ω]
0	33 404
5	25 902
10	20 247
15	15 950
20	12 657
25	10 115
30	8 138
35	6 589
40	5 367
45	4 398
50	3 624
55	3 002
60	2 500
65	2 092
70	1 759
75	1 486
80	1 260
85	1 074
90	918.3
95	788.5

Table 39 Flow temperature sensor

13.3.2 Sensor values - Cylinder temperature sensor

Temperature [°C ± 10 %]	Resistance [kΩ]
0	35 964
5	28 507
10	22 756
15	18 273
20	14 768
25	11 977
30	9 783
35	8 045
40	6 650
45	5 521
50	4 606
55	3 855
60	3 242
65	2 744
70	2 332
75	1 989
80	1 703
85	1 463
90	1 262
95	1 093

Table 40 Cylinder temperature sensor

13.3.3 Sensor values - Flue overhear thermostat

Normally closed thermostat	Temperature (°C)	Resistance (Ω)
Opening temperature	≥ 112	3500
Close temperature	≤ 111	6500

Table 41 Flue overhear thermostat

13.3.4 Sensor values - Heat exchanger assembly temperate limiter

Normally closed thermostat	Temperature (°C)
Opening temperature	≥ 120
Close temperature	≤ 80

Table 42 Heat exchanger assembly temperate limiter

13.3.5 Sensor values - Outside temperature sensor

Temperature [°C ± 10 %]	Resistance [Ω]
-20	2 392
-16	2 088
-12	1 811
-8	1 562
-4	1 342
0	1 149
4	984
8	842
12	720
16	616
20	528
24	454

Table 43 Outside temperature sensor (for weather-compensated control units, accessory)

13.4 Code plug

Type	Gas type	Number
GR4700iW 24 S	Natural gas	20025
GR4700iW 24 S	Liquid propane (LPG)	20165
GR4700iW 21 S	Natural gas	20166
GR4700iW 21 S	Liquid propane (LPG)	20167
GR4700iW 18 S	Natural gas	20168
GR4700iW 18 S	Liquid propane (LPG)	20169
GR4700iW 15 S	Natural gas	20170
GR4700iW 15 S	Liquid propane (LPG)	20171
GR4700iW 12 S	Natural gas	20172
GR4700iW 12 S	Liquid propane (LPG)	20173

Table 44 Code plug

13.5 Pump characteristic map of the heating pump

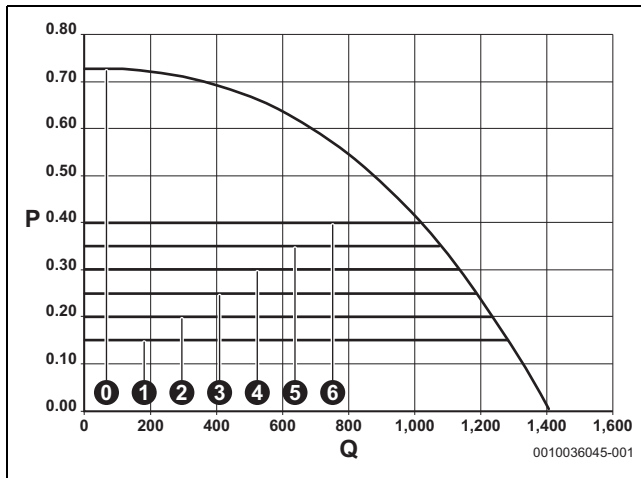

Fig. 101 Pump characteristic maps and pump curves

- [0] Pump curve at maximum pump rate
 - [1] Pump characteristic map, constant pressure 150 mbar
 - [2] Pump characteristic map, constant pressure 200 mbar
 - [3] Pump characteristic map, constant pressure 250 mbar
 - [4] Pump characteristic map, constant pressure 300 mbar
 - [5] Pump characteristic map, constant pressure 350 mbar
 - [6] Pump characteristic map, constant pressure 400 mbar
- P Pressure (bar)
 Q Volumetric flow rate (l/hr)

Constant pressure

If the constant pressure **Pump range map** (1 - 6) is chosen, the differential pressure between the CH flow and return will be kept at the corresponding value. When the CH system is cold and the radiator TRVs are fully open, the pump will be running faster to try and maintain the pressure differential. When the TRVs start to close and the resistance of the CH system increases, the pump speed reduces to maintain the pressure.

The setting (1 - 6) to be selected is dependent upon the resistance and heat load of the CH system. The higher these are, the higher the pressure constant.

13.6 Internal wiring of the appliance

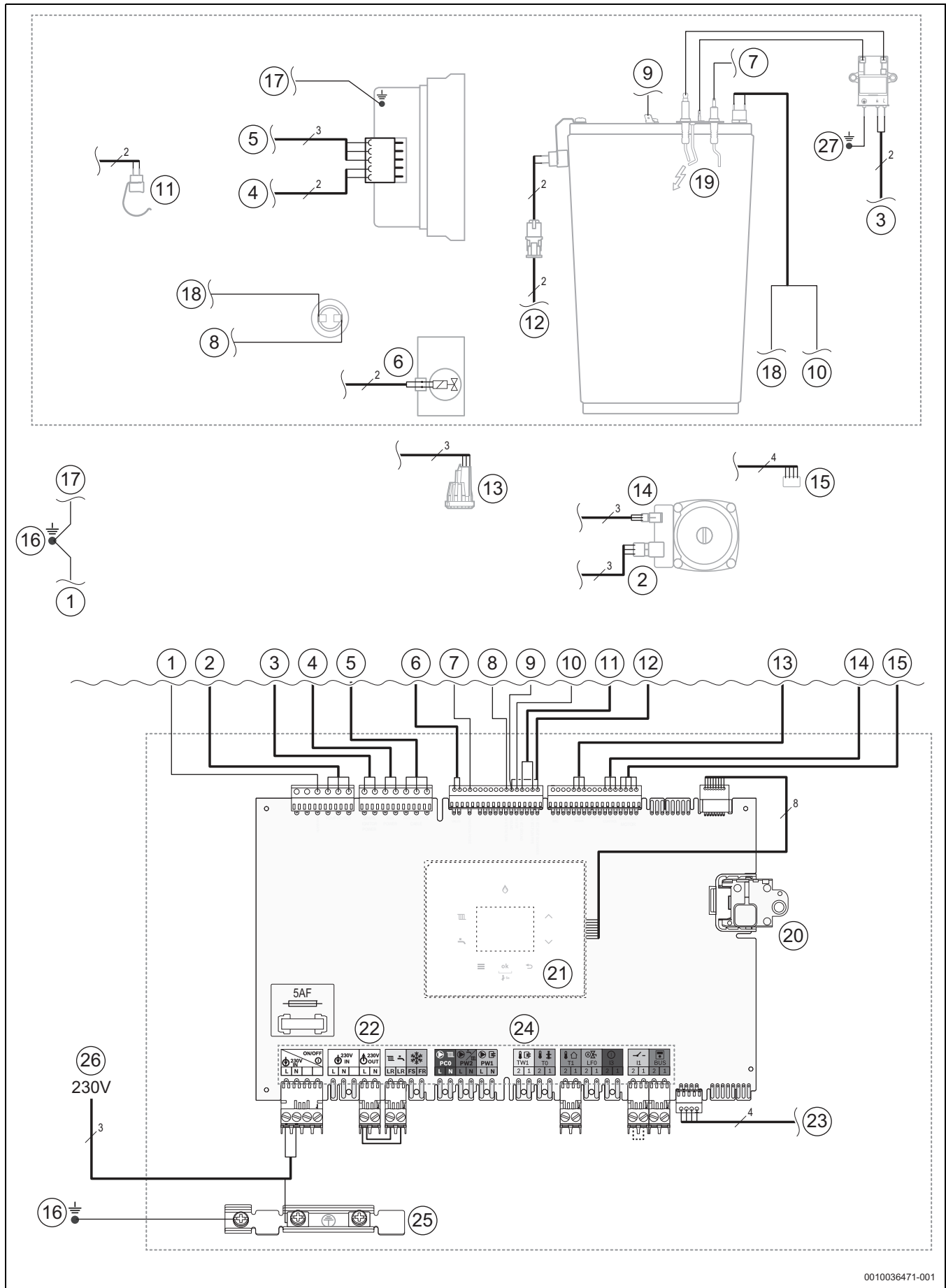

0010036471-001

Fig. 102 Electrical wiring

Legend to figure 102:

- [1] PCB earth
- [2] Pump power cable (230V)
- [3] Ignition transformer
- [4] Fan power Cable (230V)
- [5] Fan control cable
- [6] Gas valve
- [7] Flame sense electrode
- [8] Flue gas temperature limiter
- [9] Ground
- [10] Heat exchanger assembly temperature limiter
- [11] Flow temperature sensor at flow pipe
- [12] Flow temperature sensor at the heat exchanger assembly
- [13] Pressure sensor
- [14] Pump control cable
- [15] Connecting lead for 3-way valve from the diverter valve kit accessory ¹⁾
- [16] Chassis earth
- [17] Fan earth
- [18] Cable between flue gas temperature limiter and heat exchanger assembly temperature limiter
- [19] Electrode set
- [20] Code plug
- [21] Display
- [22] Terminals for Installer connections
- [23] Connecting lead for Key accessory slot
- [24] Connection for the cylinder sensor from the diverter valve kit accessory ²⁾
- [25] Earth rail
- [26] Boiler mains cable (230V)
- [27] Ignition transformer earth

1) Only applicable when fitting the optional integral diverter valve kit.

2) Supplied with optional integral diverter valve kit.

GAS BOILER SYSTEM COMMISSIONING CHECKLIST & WARRANTY VALIDATION RECORD

Address:													
Boiler make and model:													
Boiler serial number:													
Commissioned by (PRINT NAME):						Gas Safe registration number:							
Company name:						Telephone number:							
Company email:						Company address:							
										Commissioning date:			
Heating and hot water system complies with the appropriate Building Regulations?											Yes		
Optional: Building Regulations Notification Number (if applicable):													
Time, temperature control and boiler interlock provided for central heating and hot water											Yes		
Boiler Plus requirements (tick the appropriate box(s))													
Boiler Plus option chosen for combination boiler in ENGLAND						Weather compensation			Smart thermostat with automation and optimisation				
						Load compensation			Flue Gas Heat Recovery				
Time and temperature control to hot water			Cylinder thermostat and programmer/timer						Combination boiler				
Zone valves			pre-existing			Fitted			Not required				
Thermostatic radiator valves			pre-existing			Fitted			Not required				
Automatic bypass to system			pre-existing			Fitted			Not required				
Underfloor heating			pre-existing			Fitted			Not required				
Water quality													
The system has been flushed, cleaned and a suitable inhibitor applied upon final fill, in accordance with BS7593 and boiler manufacturers' instructions											Yes		
What system cleaner was used?						Brand:			Product:				
What inhibitor was used?						Brand:			Product:				
Primary water system filter			pre-existing			Fitted			Not required				
CENTRAL HEATING MODE measure and record (as appropriate)													
Gas rate (for combination boilers complete DHW mode gas rate)						m ³ /hr			or			ft ³ /hr	
Central heating output left at factory settings?											Yes	No	
If no, what is the maximum central heating output selected?											kW		
Dynamic gas inlet pressure											mbar		
Central heating flow temperature											°C		
Central heating return temperature											°C		
System correctly balanced/rebalanced?											Yes		
COMBINATION BOILERS ONLY													
Is the installation in a hard water area (above 200ppm)?											Yes	No	
Water scale reducer/softener			pre-existing			Fitted			Not required				
What type of scale reducer/softener has been fitted?						Brand:			Product:				
Water meter fitted?											Yes	No	
If yes- DHW expansion vessel			pre-existing			Fitted			Not required				
Pressure reducing valve			pre-existing			Fitted			Not required				
DOMESTIC HOT WATER MODE Measure and record													
Gas rate						m ³ /hr			or			ft ³ /hr	
Dynamic gas inlet pressure at maximum rate											mbar		
Cold water inlet temperature											°C		
Hot water has been checked at all outlets											Yes	Temperature	°C
CONDENSATE DISPOSAL													
The condensate drain has been installed in accordance with the manufacturers' instructions and/or BS5546/BS6798											Yes		
Point of termination						Internal			External (only where internal termination impractical)				
Method of disposal						Gravity			Pumped				
ALL INSTALLATIONS													
Record the following		At max rate:		CO ppm		CO ₂ %		CO/CO ₂ Ratio					
		At min rate (where possible)		CO ppm		CO ₂ %		CO/CO ₂ Ratio					
Where possible, has a flue integrity check been undertaken in accordance with manufacturers' instructions, and readings are correct?											Yes		
The operation of the boiler and system controls have been demonstrated to and understood by the customer											Yes		
The manufacturers' literature, including Benchmark Checklist and Service Record, has been explained and left with the customer											Yes		
Commissioning Engineer's signature													
Customer's signature (To confirm satisfactory demonstration and receipt of manufacturers' literature)													

* All installations in England and Wales must be notified to Local Authority Building Control (LABC) either directly or through a Competent Persons Scheme. A Building Regulations Compliance Certificate will then be issued to the customer.

13.8 Inspection and maintenance checklist

Inspection and maintenance checklist		Year 1	Year 2	Year 3	Year 4	Year 5	Year 6	Year 7	Year 8	Year 9	Year 10	Year 11	Year 12	Year 13	Year 14	Year 15
Date:																
1	Check appliance operation (CH & DHW) and fault history	Yes <input type="checkbox"/>	Yes <input type="checkbox"/>	Yes <input type="checkbox"/>	Yes <input type="checkbox"/>	Yes <input type="checkbox"/>	Yes <input type="checkbox"/>	Yes <input type="checkbox"/>	Yes <input type="checkbox"/>	Yes <input type="checkbox"/>	Yes <input type="checkbox"/>	Yes <input type="checkbox"/>	Yes <input type="checkbox"/>	Yes <input type="checkbox"/>	Yes <input type="checkbox"/>	Yes <input type="checkbox"/>
2	Visual Inspection:- Check compliance of appliance, system and components	Yes <input type="checkbox"/>	Yes <input type="checkbox"/>	Yes <input type="checkbox"/>	Yes <input type="checkbox"/>	Yes <input type="checkbox"/>	Yes <input type="checkbox"/>	Yes <input type="checkbox"/>	Yes <input type="checkbox"/>	Yes <input type="checkbox"/>	Yes <input type="checkbox"/>	Yes <input type="checkbox"/>	Yes <input type="checkbox"/>	Yes <input type="checkbox"/>	Yes <input type="checkbox"/>	Yes <input type="checkbox"/>
3	Internal visual inspection Check for signs of leaking, corrosion and distress	Yes <input type="checkbox"/>	Yes <input type="checkbox"/>	Yes <input type="checkbox"/>	Yes <input type="checkbox"/>	Yes <input type="checkbox"/>	Yes <input type="checkbox"/>	Yes <input type="checkbox"/>	Yes <input type="checkbox"/>	Yes <input type="checkbox"/>	Yes <input type="checkbox"/>	Yes <input type="checkbox"/>	Yes <input type="checkbox"/>	Yes <input type="checkbox"/>	Yes <input type="checkbox"/>	Yes <input type="checkbox"/>
4	Appliance performance checks:															
4.1	Check Fan pressure test was cleaning required?	Yes <input type="checkbox"/>	Yes <input type="checkbox"/>	Yes <input type="checkbox"/>	Yes <input type="checkbox"/>	Yes <input type="checkbox"/>	Yes <input type="checkbox"/>	Yes <input type="checkbox"/>	Yes <input type="checkbox"/>	Yes <input type="checkbox"/>	Yes <input type="checkbox"/>	Yes <input type="checkbox"/>	Yes <input type="checkbox"/>	Yes <input type="checkbox"/>	Yes <input type="checkbox"/>	Yes <input type="checkbox"/>
4.2	Check and clean syphon	No <input type="checkbox"/>	No <input type="checkbox"/>	No <input type="checkbox"/>	No <input type="checkbox"/>	No <input type="checkbox"/>	No <input type="checkbox"/>	No <input type="checkbox"/>	No <input type="checkbox"/>	No <input type="checkbox"/>	No <input type="checkbox"/>	No <input type="checkbox"/>	No <input type="checkbox"/>	No <input type="checkbox"/>	No <input type="checkbox"/>	No <input type="checkbox"/>
4.3	Correct working gas inlet pressure	Yes <input type="checkbox"/>	Yes <input type="checkbox"/>	Yes <input type="checkbox"/>	Yes <input type="checkbox"/>	Yes <input type="checkbox"/>	Yes <input type="checkbox"/>	Yes <input type="checkbox"/>	Yes <input type="checkbox"/>	Yes <input type="checkbox"/>	Yes <input type="checkbox"/>	Yes <input type="checkbox"/>	Yes <input type="checkbox"/>	Yes <input type="checkbox"/>	Yes <input type="checkbox"/>	Yes <input type="checkbox"/>
4.4	Flue gas analysis Check combustion settings: Min/Max test modes	Yes <input type="checkbox"/>	Yes <input type="checkbox"/>	Yes <input type="checkbox"/>	Yes <input type="checkbox"/>	Yes <input type="checkbox"/>	Yes <input type="checkbox"/>	Yes <input type="checkbox"/>	Yes <input type="checkbox"/>	Yes <input type="checkbox"/>	Yes <input type="checkbox"/>	Yes <input type="checkbox"/>	Yes <input type="checkbox"/>	Yes <input type="checkbox"/>	Yes <input type="checkbox"/>	Yes <input type="checkbox"/>
4.5	Gas rate appliance at maximum output in test mode	Yes <input type="checkbox"/>	Yes <input type="checkbox"/>	Yes <input type="checkbox"/>	Yes <input type="checkbox"/>	Yes <input type="checkbox"/>	Yes <input type="checkbox"/>	Yes <input type="checkbox"/>	Yes <input type="checkbox"/>	Yes <input type="checkbox"/>	Yes <input type="checkbox"/>	Yes <input type="checkbox"/>	Yes <input type="checkbox"/>	Yes <input type="checkbox"/>	Yes <input type="checkbox"/>	Yes <input type="checkbox"/>
4.6	Check flame failure appliance	Yes <input type="checkbox"/>	Yes <input type="checkbox"/>	Yes <input type="checkbox"/>	Yes <input type="checkbox"/>	Yes <input type="checkbox"/>	Yes <input type="checkbox"/>	Yes <input type="checkbox"/>	Yes <input type="checkbox"/>	Yes <input type="checkbox"/>	Yes <input type="checkbox"/>	Yes <input type="checkbox"/>	Yes <input type="checkbox"/>	Yes <input type="checkbox"/>	Yes <input type="checkbox"/>	Yes <input type="checkbox"/>
4.7	Fit casing	Yes <input type="checkbox"/>	Yes <input type="checkbox"/>	Yes <input type="checkbox"/>	Yes <input type="checkbox"/>	Yes <input type="checkbox"/>	Yes <input type="checkbox"/>	Yes <input type="checkbox"/>	Yes <input type="checkbox"/>	Yes <input type="checkbox"/>	Yes <input type="checkbox"/>	Yes <input type="checkbox"/>	Yes <input type="checkbox"/>	Yes <input type="checkbox"/>	Yes <input type="checkbox"/>	Yes <input type="checkbox"/>
4.8	Check flue integrity	Yes <input type="checkbox"/>	Yes <input type="checkbox"/>	Yes <input type="checkbox"/>	Yes <input type="checkbox"/>	Yes <input type="checkbox"/>	Yes <input type="checkbox"/>	Yes <input type="checkbox"/>	Yes <input type="checkbox"/>	Yes <input type="checkbox"/>	Yes <input type="checkbox"/>	Yes <input type="checkbox"/>	Yes <input type="checkbox"/>	Yes <input type="checkbox"/>	Yes <input type="checkbox"/>	Yes <input type="checkbox"/>
6	Gas Safe/Benchmark documentation updated	Yes <input type="checkbox"/>	Yes <input type="checkbox"/>	Yes <input type="checkbox"/>	Yes <input type="checkbox"/>	Yes <input type="checkbox"/>	Yes <input type="checkbox"/>	Yes <input type="checkbox"/>	Yes <input type="checkbox"/>	Yes <input type="checkbox"/>	Yes <input type="checkbox"/>	Yes <input type="checkbox"/>	Yes <input type="checkbox"/>	Yes <input type="checkbox"/>	Yes <input type="checkbox"/>	Yes <input type="checkbox"/>
8	Appliance left to customer settings	Yes <input type="checkbox"/>	Yes <input type="checkbox"/>	Yes <input type="checkbox"/>	Yes <input type="checkbox"/>	Yes <input type="checkbox"/>	Yes <input type="checkbox"/>	Yes <input type="checkbox"/>	Yes <input type="checkbox"/>	Yes <input type="checkbox"/>	Yes <input type="checkbox"/>	Yes <input type="checkbox"/>	Yes <input type="checkbox"/>	Yes <input type="checkbox"/>	Yes <input type="checkbox"/>	Yes <input type="checkbox"/>
9	Gas Safe registration number	Yes <input type="checkbox"/>	Yes <input type="checkbox"/>	Yes <input type="checkbox"/>	Yes <input type="checkbox"/>	Yes <input type="checkbox"/>	Yes <input type="checkbox"/>	Yes <input type="checkbox"/>	Yes <input type="checkbox"/>	Yes <input type="checkbox"/>	Yes <input type="checkbox"/>	Yes <input type="checkbox"/>	Yes <input type="checkbox"/>	Yes <input type="checkbox"/>	Yes <input type="checkbox"/>	Yes <input type="checkbox"/>
Gas Safe Engineers Signature																

Table 45 Inspection and maintenance checklist

SERVICE & INTERIM BOILER WORK RECORD

It is recommended that your boiler and heating system are regularly serviced and maintained, in line with manufacturers' instructions, and that the appropriate service / interim work record is completed.

Service provider

When completing a service record (as below), please ensure you have carried out the service as described in the manufacturers' instructions. Always use the manufacturers' specified spare parts.

SERVICE/INTERIM WORK ON BOILER <small>delete as appropriate</small>					Date:	
Engineer name:		Company name:				
Telephone N°:		Gas Safe registration N°:				
Max rate	CO	ppm	CO ₂	%	CO/CO ₂	
Min rate	CO	ppm	CO ₂	%	CO/CO ₂	
Where possible, has a flue integrity check been undertaken in accordance with manufacturers' instructions, and readings are correct?"					yes	
Gas rate:	m ³ /h	OR	ft ³ /h			
Were parts fitted? <small>delete as appropriate</small>		Yes	No			
Parts fitted:						
System inhibitor concentration has been checked and appropriate action taken, in accordance with BS 7593 and boiler manufacturers' instructions. *					yes	n/a
Comments:						
Signature:						

*A System inhibitor efficacy test is required on every annual service in accordance with the manufacturers' instructions and BS 7593. It is only acceptable to not have undertaken this if the service engineers attendance visit was in between annual services to attend a non-water facing component.

SERVICE/INTERIM WORK ON BOILER <small>delete as appropriate</small>					Date:	
Engineer name:		Company name:				
Telephone N°:		Gas Safe registration N°:				
Max rate	CO	ppm	CO ₂	%	CO/CO ₂	
Min rate	CO	ppm	CO ₂	%	CO/CO ₂	
Where possible, has a flue integrity check been undertaken in accordance with manufacturers' instructions, and readings are correct?"					yes	
Gas rate:	m ³ /h	OR	ft ³ /h			
Were parts fitted? <small>delete as appropriate</small>		Yes	No			
Parts fitted:						
System inhibitor concentration has been checked and appropriate action taken, in accordance with BS 7593 and boiler manufacturers' instructions. *					yes	n/a
Comments:						
Signature:						

*A System inhibitor efficacy test is required on every annual service in accordance with the manufacturers' instructions and BS 7593. It is only acceptable to not have undertaken this if the service engineers attendance visit was in between annual services to attend a non-water facing component.

SERVICE/INTERIM WORK ON BOILER <small>delete as appropriate</small>					Date:	
Engineer name:		Company name:				
Telephone N°:		Gas Safe registration N°:				
Max rate	CO	ppm	CO ₂	%	CO/CO ₂	
Min rate	CO	ppm	CO ₂	%	CO/CO ₂	
Where possible, has a flue integrity check been undertaken in accordance with manufacturers' instructions, and readings are correct?"					yes	
Gas rate:	m ³ /h	OR	ft ³ /h			
Were parts fitted? <small>delete as appropriate</small>		Yes	No			
Parts fitted:						
System inhibitor concentration has been checked and appropriate action taken, in accordance with BS 7593 and boiler manufacturers' instructions. *					yes	n/a
Comments:						
Signature:						

*A System inhibitor efficacy test is required on every annual service in accordance with the manufacturers' instructions and BS 7593. It is only acceptable to not have undertaken this if the service engineers attendance visit was in between annual services to attend a non-water facing component.

SERVICE/INTERIM WORK ON BOILER <small>delete as appropriate</small>					Date:	
Engineer name:		Company name:				
Telephone N°:		Gas Safe registration N°:				
Max rate	CO	ppm	CO ₂	%	CO/CO ₂	
Min rate	CO	ppm	CO ₂	%	CO/CO ₂	
Where possible, has a flue integrity check been undertaken in accordance with manufacturers' instructions, and readings are correct?"					yes	
Gas rate:	m ³ /h	OR	ft ³ /h			
Were parts fitted? <small>delete as appropriate</small>		Yes	No			
Parts fitted:						
System inhibitor concentration has been checked and appropriate action taken, in accordance with BS 7593 and boiler manufacturers' instructions. *					yes	n/a
Comments:						
Signature:						

*A System inhibitor efficacy test is required on every annual service in accordance with the manufacturers' instructions and BS 7593. It is only acceptable to not have undertaken this if the service engineers attendance visit was in between annual services to attend a non-water facing component.

SERVICE/INTERIM WORK ON BOILER <small>delete as appropriate</small>					Date:	
Engineer name:		Company name:				
Telephone N°:		Gas Safe registration N°:				
Max rate	CO	ppm	CO ₂	%	CO/CO ₂	
Min rate	CO	ppm	CO ₂	%	CO/CO ₂	
Where possible, has a flue integrity check been undertaken in accordance with manufacturers' instructions, and readings are correct?"					yes	
Gas rate:	m ³ /h	OR	ft ³ /h			
Were parts fitted? <small>delete as appropriate</small>		Yes	No			
Parts fitted:						
System inhibitor concentration has been checked and appropriate action taken, in accordance with BS 7593 and boiler manufacturers' instructions. *					yes	n/a
Comments:						
Signature:						

*A System inhibitor efficacy test is required on every annual service in accordance with the manufacturers' instructions and BS 7593. It is only acceptable to not have undertaken this if the service engineers attendance visit was in between annual services to attend a non-water facing component.

SERVICE/INTERIM WORK ON BOILER <small>delete as appropriate</small>					Date:	
Engineer name:		Company name:				
Telephone N°:		Gas Safe registration N°:				
Max rate	CO	ppm	CO ₂	%	CO/CO ₂	
Min rate	CO	ppm	CO ₂	%	CO/CO ₂	
Where possible, has a flue integrity check been undertaken in accordance with manufacturers' instructions, and readings are correct?"					yes	
Gas rate:	m ³ /h	OR	ft ³ /h			
Were parts fitted? <small>delete as appropriate</small>		Yes	No			
Parts fitted:						
System inhibitor concentration has been checked and appropriate action taken, in accordance with BS 7593 and boiler manufacturers' instructions. *					yes	n/a
Comments:						
Signature:						

*A System inhibitor efficacy test is required on every annual service in accordance with the manufacturers' instructions and BS 7593. It is only acceptable to not have undertaken this if the service engineers attendance visit was in between annual services to attend a non-water facing component.

* All installations in England and Wales must be notified to Local Authority Building Control (LABC) either directly or through a Competent Persons Scheme. A Building Regulations Compliance Certificate will then be issued to the customer.

© Heating and Hotwater Industry Council (HHIC)



www.centralheating.co.uk

SERVICE & INTERIM BOILER WORK RECORD

It is recommended that your boiler and heating system are regularly serviced and maintained, in line with manufacturers' instructions, and that the appropriate service / interim work record is completed.

Service provider

When completing a service record (as below), please ensure you have carried out the service as described in the manufacturers' instructions. Always use the manufacturers' specified spare parts.

SERVICE/INTERIM WORK ON BOILER <small>delete as appropriate</small>					Date:	
Engineer name:		Company name:				
Telephone N°:		Gas Safe registration N°:				
Max rate	CO	ppm	CO ₂	%	CO/CO ₂	
Min rate	CO	ppm	CO ₂	%	CO/CO ₂	
Where possible, has a flue integrity check been undertaken in accordance with manufacturers' instructions, and readings are correct?"					yes	
Gas rate:	m ³ /h	OR	ft ³ /h			
Were parts fitted? <small>delete as appropriate</small>		Yes	No			
Parts fitted:						
System inhibitor concentration has been checked and appropriate action taken, in accordance with BS 7593 and boiler manufacturers' instructions. *					yes	n/a
Comments:						
Signature:						

*A System inhibitor efficacy test is required on every annual service in accordance with the manufacturers' instructions and BS 7593. It is only acceptable to not have undertaken this if the service engineers attendance visit was in between annual services to attend a non-water facing component.

SERVICE/INTERIM WORK ON BOILER <small>delete as appropriate</small>					Date:	
Engineer name:		Company name:				
Telephone N°:		Gas Safe registration N°:				
Max rate	CO	ppm	CO ₂	%	CO/CO ₂	
Min rate	CO	ppm	CO ₂	%	CO/CO ₂	
Where possible, has a flue integrity check been undertaken in accordance with manufacturers' instructions, and readings are correct?"					yes	
Gas rate:	m ³ /h	OR	ft ³ /h			
Were parts fitted? <small>delete as appropriate</small>		Yes	No			
Parts fitted:						
System inhibitor concentration has been checked and appropriate action taken, in accordance with BS 7593 and boiler manufacturers' instructions. *					yes	n/a
Comments:						
Signature:						

*A System inhibitor efficacy test is required on every annual service in accordance with the manufacturers' instructions and BS 7593. It is only acceptable to not have undertaken this if the service engineers attendance visit was in between annual services to attend a non-water facing component.

SERVICE/INTERIM WORK ON BOILER <small>delete as appropriate</small>					Date:	
Engineer name:		Company name:				
Telephone N°:		Gas Safe registration N°:				
Max rate	CO	ppm	CO ₂	%	CO/CO ₂	
Min rate	CO	ppm	CO ₂	%	CO/CO ₂	
Where possible, has a flue integrity check been undertaken in accordance with manufacturers' instructions, and readings are correct?"					yes	
Gas rate:	m ³ /h	OR	ft ³ /h			
Were parts fitted? <small>delete as appropriate</small>		Yes	No			
Parts fitted:						
System inhibitor concentration has been checked and appropriate action taken, in accordance with BS 7593 and boiler manufacturers' instructions. *					yes	n/a
Comments:						
Signature:						

*A System inhibitor efficacy test is required on every annual service in accordance with the manufacturers' instructions and BS 7593. It is only acceptable to not have undertaken this if the service engineers attendance visit was in between annual services to attend a non-water facing component.

SERVICE/INTERIM WORK ON BOILER <small>delete as appropriate</small>					Date:	
Engineer name:		Company name:				
Telephone N°:		Gas Safe registration N°:				
Max rate	CO	ppm	CO ₂	%	CO/CO ₂	
Min rate	CO	ppm	CO ₂	%	CO/CO ₂	
Where possible, has a flue integrity check been undertaken in accordance with manufacturers' instructions, and readings are correct?"					yes	
Gas rate:	m ³ /h	OR	ft ³ /h			
Were parts fitted? <small>delete as appropriate</small>		Yes	No			
Parts fitted:						
System inhibitor concentration has been checked and appropriate action taken, in accordance with BS 7593 and boiler manufacturers' instructions. *					yes	n/a
Comments:						
Signature:						

*A System inhibitor efficacy test is required on every annual service in accordance with the manufacturers' instructions and BS 7593. It is only acceptable to not have undertaken this if the service engineers attendance visit was in between annual services to attend a non-water facing component.

SERVICE/INTERIM WORK ON BOILER <small>delete as appropriate</small>					Date:	
Engineer name:		Company name:				
Telephone N°:		Gas Safe registration N°:				
Max rate	CO	ppm	CO ₂	%	CO/CO ₂	
Min rate	CO	ppm	CO ₂	%	CO/CO ₂	
Where possible, has a flue integrity check been undertaken in accordance with manufacturers' instructions, and readings are correct?"					yes	
Gas rate:	m ³ /h	OR	ft ³ /h			
Were parts fitted? <small>delete as appropriate</small>		Yes	No			
Parts fitted:						
System inhibitor concentration has been checked and appropriate action taken, in accordance with BS 7593 and boiler manufacturers' instructions. *					yes	n/a
Comments:						
Signature:						

*A System inhibitor efficacy test is required on every annual service in accordance with the manufacturers' instructions and BS 7593. It is only acceptable to not have undertaken this if the service engineers attendance visit was in between annual services to attend a non-water facing component.

SERVICE/INTERIM WORK ON BOILER <small>delete as appropriate</small>					Date:	
Engineer name:		Company name:				
Telephone N°:		Gas Safe registration N°:				
Max rate	CO	ppm	CO ₂	%	CO/CO ₂	
Min rate	CO	ppm	CO ₂	%	CO/CO ₂	
Where possible, has a flue integrity check been undertaken in accordance with manufacturers' instructions, and readings are correct?"					yes	
Gas rate:	m ³ /h	OR	ft ³ /h			
Were parts fitted? <small>delete as appropriate</small>		Yes	No			
Parts fitted:						
System inhibitor concentration has been checked and appropriate action taken, in accordance with BS 7593 and boiler manufacturers' instructions. *					yes	n/a
Comments:						
Signature:						

*A System inhibitor efficacy test is required on every annual service in accordance with the manufacturers' instructions and BS 7593. It is only acceptable to not have undertaken this if the service engineers attendance visit was in between annual services to attend a non-water facing component.

* All installations in England and Wales must be notified to Local Authority Building Control (LABC) either directly or through a Competent Persons Scheme. A Building Regulations Compliance Certificate will then be issued to the customer.

© Heating and Hotwater Industry Council (HHIC)



www.centralheating.co.uk

TECHNICAL SUPPORT: 0330 123 3366
RENEWABLE SUPPORT: 0330 123 9229
CONTROLS AND CONNECTIVITY TEAM: 0330 123 3641
APPOINTMENTS: 0330 123 9339
SPARES: 0330 123 9779
LITERATURE: 0330 123 9119
TRAINING: 0330 123 0166
SALES: 0330 123 9669

Bosch Thermotechnology Ltd.
Cotswold Way, Warndon
Worcester WR4 9SW
United Kingdom
Tel. 0330 123 9559
worcester-bosch.co.uk

