

WORCESTER

Bosch Group

24Si II / 28Si II

WALL MOUNTED COMBINATION BOILERS FOR CENTRAL HEATING
AND MAINS FED DOMESTIC HOT WATER

INSTALLATION AND SERVICING INSTRUCTIONS

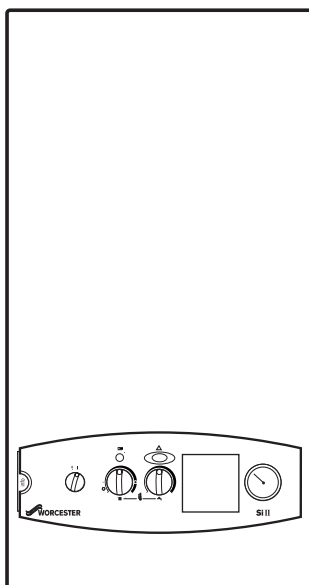

Worcester supports the
Benchmark code of practice

This appliance is for use with Natural Gas or LPG (Cat II 2H3P TYPE C12 & C32)

24SiII GC NUMBER 47 311 65 (N.G.)

GC NUMBER 47 311 66 (L.P.G.)

28SiII GC NUMBER 47 311 67 (N.G.)

GC NUMBER 47 311 68 (L.P.G.)

GB/IE

APPLIANCE OUTPUTS

	Domestic Hot Water		Central Heating	
	24Si II	28Si II	24Si II	28Si II
Minimum	6.9 kW	8.1 kW	6.9 kW	8.1 kW
Maximum	24 kW	28 kW	24 kW	28 kW

IMPORTANT: THESE INSTRUCTIONS APPLY IN THE GB/IE ONLY

AND MUST BE LEFT WITH THE USER OR AT THE GAS METER

It is IMPORTANT to read the instructions before starting work - they have been written to make the installation easier and prevent hold-ups.

Contents

1. Installation Regulations	Page 2
2. Introduction	Page 2
3. Technical Data	Page 4
4. Siting the Appliance	Page 7
5. Flue Terminal Positions	Page 7
6. Air Supply	Page 8
7. Sealed System	Page 8
Open Vent System	Page 8
8. Domestic Hot Water	Page 9
9. Gas Supply	Page 9

10. Electrical	Page 9
11. Installing the Appliance	Page 12
12. Commissioning the Appliance	Page 19
13. Handover	Page 21
14. Inspection and Service	Page 21
15. Replacement of Parts	Page 24
16. Short Parts List	Page 30
17. Operational Flow Diagram	Page 32
18. Fault Finding	Page 34
19. Conversion Instructions	Page 42

1. Installation Regulations

1.1 Gas Safety (Installation & Use) Regulations 1998:

The appliance is suitable for installation in GB/IE only and should be installed in accordance with the rules in force.

It is the law in GB that a competent person in accordance with the above regulations installs all gas appliances.

Failure to install appliances correctly could lead to prosecution.

It is in your interest, and that of safety, to ensure compliance with the law.

1.2 The manufacturers notes must not be taken, in any way, as overriding statutory obligations.

1.3 The compliance with a British Standard or European Norm does not, in itself, confer immunity from legal obligations.

1.4.1 The installation of the appliance must be in accordance with the relevant requirements of the Gas Safety Regulations, current IEE Regulations, Building Regulations, Building Standards (Scotland) and local water by-laws.

1.4.2 In Eire the installation must be carried out by a competent person and installed in accordance with IS 813, Domestic Gas Installations (Edition 2), the current building regulations and the electrical installation must follow the ETCI rules.

1.5 The installation should follow the recommendations of the following British Standards unless otherwise indicated.

- BS5440:1 - Flues and ventilation for gas appliances: Flues
- BS5440:2 - Flues and ventilation for gas appliances: Air supply.
- BS5449 - Central heating for domestic premises.
- BS5482 - Domestic propane gas burning installations.
- BS5546:1 - Installation of gas hot water supplies.
- BS6700 - Domestic water supply in buildings.
- BS6798 - Installation of gas fired hot water boilers.
- BS6891 - Low pressure gas pipework installations upto 28mm (R1).
- BS7593 - Water treatment.
- BS7671 - Requirements for electrical installations.

1.6 The appliance does not contain any substances which are harmful to health.

1.7 In certain circumstances, the installer can be held responsible, not only for mistakes on his part but also for damage resulting from the use of faulty materials. We advise that, to avoid any risk, only quality approved branded fittings are used.

1.8 LPG Installation:

The appliance shall not be installed in a room or internal space below ground level when it is intended for use with LPG. This does not preclude the installation into rooms, which are basements with respect to one side of the building but open to the ground on the opposite side.

1.9 These instructions cover, as far as possible, the foreseeable situations, which may arise.

Contact The Worcester Technical Department, Telephone: 08705 266241, for advice on specific installations.

2. Introduction

2.1 The *(benchmark)* initiative is the new code of practice to encourage the correct installation, commissioning and servicing of domestic central heating boilers and system equipment.

The 'checklist' is a vital document that must be completed by the installer at the time of installation. It confirms that the boiler has been installed and commissioned according to the manufacturers instructions.

A declaration of conformity (Refer to IS 813 Annex D1) must be completed by the installer and a copy supplied to the appliance operator for boilers installed in Eire.

Without the completion of the checklist and/or declaration, manufacturers may refuse to respond to a call-out from a householder, who will be advised that he or she must call back the installer, who has not fulfilled his obligations to record the information required by the initiative.

Service:

To ensure continued efficient operation of the appliance it must be checked at regular intervals. The frequency of servicing will depend upon the particular installation conditions and usage, but once per year should generally be adequate. The extent of the service required by the appliance is determined by the operating condition of the appliance when tested by fully qualified engineers.

Any service work must be carried out by competent registered engineers (CORGI in GB).

2.2 General Information

The appliance is set to give the maximum output of 28 kW [28Si II] or 24kW [24Si II] to the domestic hot water and to the heating system. The hot water flow rate is limited to a nominal 10 l/min [28Si II] or 8 l/min [24Si II] at a maximum temperature rise of 40°C.

The sanitary water section of the appliance is suitable for mains water pressure of upto 10bar.

Kits are available to convert the appliance from Natural Gas to Propane operation and vice versa.

2.3 Electrical Supply

230V - 50Hz. Load 180 watts. External fuse 3A (to BS1362), Internal fuses F1 - 2A, F2 - 1.25A (20mm).

2.4 Gas Supply

The appliances require a maximum of 3.25 m³/h of natural gas (G20) or 1.25 m³/h of propane (G31) [28Si II] or 2.8 m³/h of natural gas (G20) or 1.08 m³/h of propane (G31) [24Si II].

The installation and the connection of the gas supply to the appliance must be in accordance with BS6891.

The meter or regulator should deliver a dynamic pressure of 20 mbar (G20) or 37mbar (G31) at the appliance, which is equivalent to about 19 mbar or 36 mbar at the gas valve inlet pressure test point.

2.5 Installation

The appliance is suitable for indoor installation only and for use with a sealed system only.

Do not place anything on top of the appliance.

This is a room sealed appliance and a separate combustion air supply is not required in any room or compartment in which the appliance is fitted.

If the appliance is fitted in a cupboard or a compartment is built around it after installation, then the structure must conform to the requirements of BS6798 and BS5440 Part 2. However, because of the low casing losses, there is no need for cooling ventilation openings in

the compartment provided the increased clearances are used. See Fig. 5.

The spaces specified for servicing must be maintained. (See Table 8). There is space for the service pipes to pass at the back of the appliance.

2.6 Flue

implefit Multi-Directional Horizontal Flue Kit.

implefit Standard Flue Kit can be adjusted from 425mm to 725mm without cutting.

The minimum length is 265 mm with cutting.

Extended flue lengths are available upto a maximum of 4m for natural gas appliances and 2.5m for LPG.

Optional 45° and 90° flue bend kits are available **NOTE:** When using flue bends the maximum flue length is reduced (see Section 11.12).

If access to the flue terminal will be a problem then a kit is available to enable the horizontal flue to be fitted from inside the house.

Do not allow the flue terminal to the outside wall to become obstructed or damaged.

A Tower guard type K2 CG 393553 is available from Tower Flue Components, Vale Rise, Tonbridge TN9 1TB.

A vertical flue system is available.

2.7 Controls

The appliance has controls for switching the appliance On or Off, [this does not electrically isolate the appliance] for adjusting the CH and DHW temperatures. The CH control knob also switches the CH off and on.

A programmable 'wire free' room thermostat or a fascia mounted programmer or clock is available.

A room thermostat and/or an externally mounted programmer for mains voltage operation may be connected to the appliance.

Fig. 1. Fascia controls

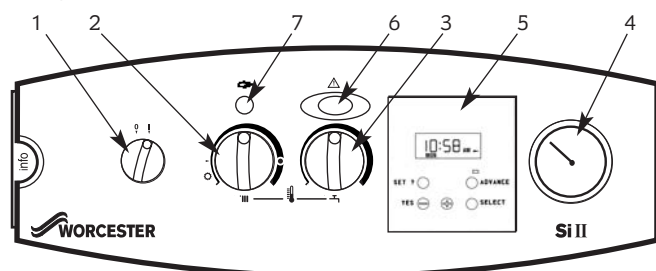

- | | |
|----------------------------|---|
| 1. Mains On/Off control | 5. Optional programmer |
| 2. CH temperature control | 6. Lockout indicator light and reset button |
| 3. DHW temperature control | 7. Burner indicator light |
| 4. System pressure gauge | |

2.8 System

benchmark All dirt must be flushed from the system before connecting the appliance. The system can be pre-piped and flushed before the appliance is fitted.

The connections in the system must withstand an operating pressure of upto 3 bar.

Radiator valves must conform to BS2767: 10:1977.

Table 3 gives the pump head available for the system and the required temperature differential.

A drain cock must be fitted to the lowest point and an air vent to the highest point of the system.

2.9 Showers, Bidets, Taps and Mixing Valves

All taps and mixing valves must be suitable for the available mains pressure and temperatures upto 65°C.

It may be necessary to fit a pressure reducing valve.

Hot and cold mains fed water can be supplied to overrim bidets but is subject to local water company requirements.

The flow of water from individual outlets varies on all mains fed systems that are not fitted with flow balancing valves.

Thermostatically controlled or pressure equalising shower valves give extra comfort and protection.

If a pressure equalising valve is fitted then the domestic hot water temperature should be set to maximum.

2.10 Safety

The appliance must not be operated with the inner casing cover removed or without being full of water and pressurised. The gas and electricity supplies must be turned off before working on the appliance.

Temperature monitoring controls are fitted to prevent overheating. Automatic frost protection is provided together with automatic pump seizure protection.

The gas valve solenoids are automatically checked for gas soundness.

IMPORTANT: Where back-flow prevention devices, including water meters, are fitted the expansion of hot water into cold water main can be prevented. This can result in a pressure build-up that may cause damage to the boiler and household devices such as showers, washing machines etc.

In these cases we recommend that a mini-expansion vessel be fitted adjacent to the boiler in the cold water supply pipe.

2.11.1 Operation

Central Heating:

A demand for heat will ignite the burner.

It will operate at minimum pressure for 15 seconds before increasing to the maximum pressure over a period of 1 minute and then automatically match the system requirements. At the end of the demand the burner will go out, the pump will continue to run for upto 4 minutes or the fan for 15 seconds. There is an anti-cycle time of 3 minutes.

2.11.2 Domestic Hot Water:

A demand for hot water will light the burner. The pressure will immediately rise to maximum. At the end of the demand the fan will continue to run for 15 seconds if there is no heating demand. There is an anti-cycle time of 10 seconds.

2.11.3 Domestic Hot Water and Central Heating Mode.

The demand for hot water will override the CH function when the appliance is in the heating and hot water mode of operation.

In winter it may be necessary to reduce the flow at the taps to maintain the delivery temperature.

Fig. 2. Water flow diagram.

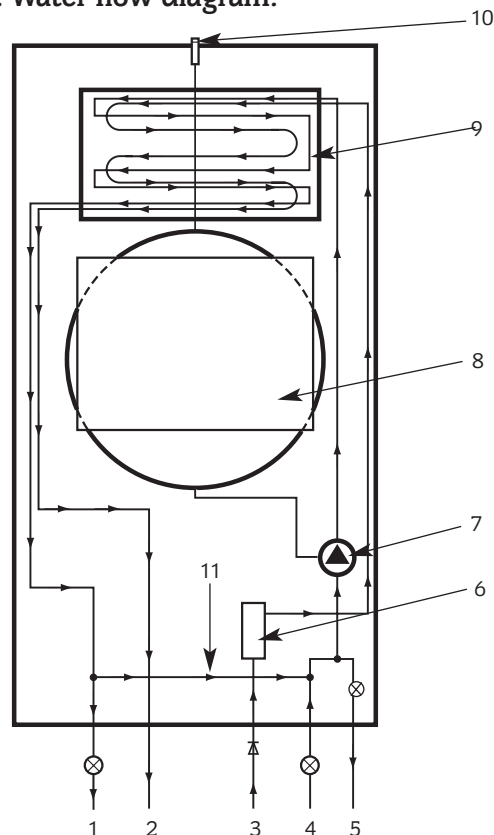

- | | |
|------------------------------------|---------------------------|
| 1. CH flow | 7. Circulating pump |
| 2. Domestic hot water flow | 8. Expansion vessel |
| 3. Domestic hot water supply | 9. Primary heat exchanger |
| 4. CH return | 10. Automatic air vent |
| 5. Pressure relief valve discharge | 11. By pass |
| 6. Domestic water flow turbine | |

3. Technical Data

Table 1. 24Si II

NOMINAL BOILER RATINGS (10 Minutes After Lighting)			
BOILER ADJUSTED FOR G20 (Natural Gas)			
OUTPUT	INPUT (Net)	BURNER PRESSURE	GAS RATE
kW	kW	m bar.	m ³ /h
6.9	7.9	0.9	0.84
24	26.4	12.1	2.8
BOILER ADJUSTED FOR G31 (Propane)			
6.9	7.9	3.1	0.32
24	26.4	35.0	1.08

Natural Gas: Net Input = Gross Input x 0.901

Table 1. 28Si II

NOMINAL BOILER RATINGS (10 Minutes After Lighting)			
BOILER ADJUSTED FOR G20 (Natural Gas)			
OUTPUT	INPUT (Net)	BURNER PRESSURE	GAS RATE
kW	kW	m bar.	m ³ /h
8.1	9.2	0.7	0.97
28	30.7	13.1	3.25
BOILER ADJUSTED FOR G31 (Propane)			
8.1	9.2	2.8	0.38
28	30.7	34.5	1.25

LPG (Propane): Net Input = Gross Input x 0.922

NOTE: With longer flue lengths, not using a restrictor, the minimum burner pressure will rise, naturally due to the flue, to 1.1mbar on G20 appliances only.

Table 2.

FLUE DETAILS			
HORIZONTAL FLUE		G20	LPG
WALL HOLE DIAMETER	EXTERNAL FIX mm	110	110
	INTERNAL FIX mm	130	130
STANDARD FLUE	MINIMUM LENGTH mm	275/*425	275/*425
	MAXIMUM LENGTH mm	725	725
EXTENDED FLUE	MAXIMUM LENGTH mm	4000	2500
FLUE ASSEMBLY DIAMETER	mm	100	100

* NOTE : Minimum uncut length

Table 3

MAXIMUM AVAILABLE PUMP HEAD			
BOILER OUTPUT kW	HEAD Metres	MIN. FLOW RATE L/min.	FLOW/RETURN DIFFERENTIAL °C
6.9	5.2	9	11
24	1.8	22	15.5
28	1.8	22	18

Table 4

MECHANICAL SPECIFICATIONS	24Si II	28Si II
CENTRAL HEATING FLOW - COMPRESSION	22mm	22mm
RETURN - COMPRESSION	22mm	22mm
COLD WATER INLET - COMPRESSION	15mm	15mm
DOMESTIC WATER FLOW - COMPRESSION	15mm	15mm
GAS INLET	Rp ³ / ₄	Rp ³ / ₄
RELIEF VALVE DISCHARGE (PUSH-IN)	15mm	15mm
CASING HEIGHT	740mm	740mm
CASING WIDTH	400mm	440mm
CASING DEPTH	360mm	360mm
WEIGHT - LIFT	36kg	36kg
WEIGHT - PACKAGED	48kg	50kg
WEIGHT - DRY	39kg	40kg

Table 5

PERFORMANCE SPECIFICATIONS		24Si II	28Si II	
PRIMARY WATER CAPACITY	litres	2.0		
IP RATING (WHOLE OF BOILER)		IP 20		
MAXIMUM MAINS INLET PRESSURE	bar	10		
MINIMUM MAINS INLET PRESSURE (WORKING) FOR MAXIMUM FLOW	bar	1.0		
MINIMUM MAINS INLET PRESSURE (WORKING) FOR OPERATION	bar	0.25		
DOMESTIC HOT WATER TEMPERATURE RANGE	°C	40 - 60		
MAXIMUM CENTRAL HEATING FLOW TEMPERATURE	°C	82 (nom)		
MAXIMUM CENTRAL HEATING SYSTEM SET PRESSURE	bar	2.65		
MINIMUM CENTRAL HEATING SYSTEM PRESSURE	bar	0.5		
OUTPUT TO CENTRAL HEATING & DHW	kw			
		NATURAL GAS (G20)	24	28
		LPG - PROPANE (G31)	24	28
DOMESTIC HOT WATER SPECIFIC RATE -	30°C RISE l/min	11.5	13.5	
MAXIMUM DOMESTIC HOT WATER FLOW RATE -	40°C RISE l/min	8.5	10	
FLUE GAS MASS FLOW RATE		14.9	17.4	
FLUE GAS TEMPERATURE °C		146.0		
NO _x CLASSIFICATION FOR BOTH 24 & 28Si II		Class 3		
SEDBUK NUMBER		78.0	78.2	
SEDBUK NUMBER LPG		80.5	80	
SEDBUK BAND*		D	D	

* The value is used in the UK Government Standard Assessment Procedure [SAP] for the energy rating of dwellings. The test data from which it has been calculated have been certified by the GASTEC notified body.

Table 6

DOMESTIC HOT WATER TEMPERATURE RISE					
DISCHARGE RATE	l/min	7	8	9	10
TEMPERATURE RISE	°C 24kw	49	43	38	34
TEMPERATURE RISE	°C 28kw	57	50	45	40

Table 7

GAS SUPPLY SYSTEM - BASED ON NG (G20)				
TOTAL LENGTH OF GAS SUPPLY PIPE (COPPER) metres				
3	6	9	12	
GAS DISCHARGE RATE - PRESSURE DROP mbar. m ³ /h				PIPE DIAMETER mm
8.7	5.8	4.6	3.9	22
18.0	12.0	9.4	8.0	28

Table 8

	CLEARANCES (mm)		
	INSTALLATION	SERVICE	UNVENTILATED COMPARTMENT
ABOVE FLUE ELBOW	30	30	150
IN FRONT OF APPLIANCE	600	600	*240
BENEATH APPLIANCE	200	200	200
RIGHT AND LEFT HAND SIDE	10	10	80

Refer to Section 6.

* Front clearance is to a removable panel (eg. door)

Table 9

SYSTEM CAPACITY			
TOTAL SYSTEM VOLUME litres			
INITIAL PRESSURE bar	INITIAL CHARGE PRESSURE bar		
	0.5	1.0	1.5
1.0	57	75	N/A
1.5	31	42	52

Fig. 3. Appliance casing dimensions and required clearances for installation/servicing

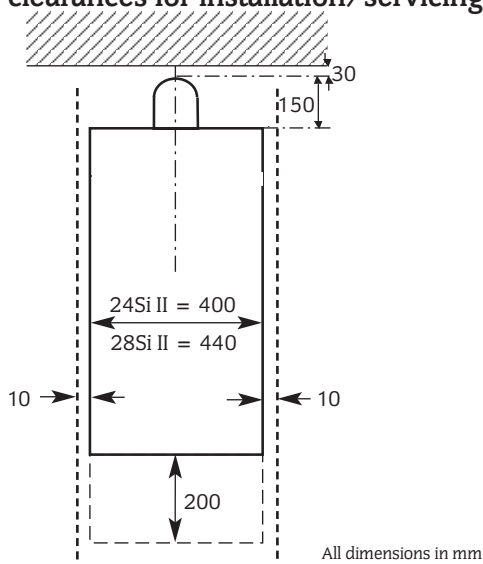

Fig. 4. Appliance casing dimensions and required clearances (side view).

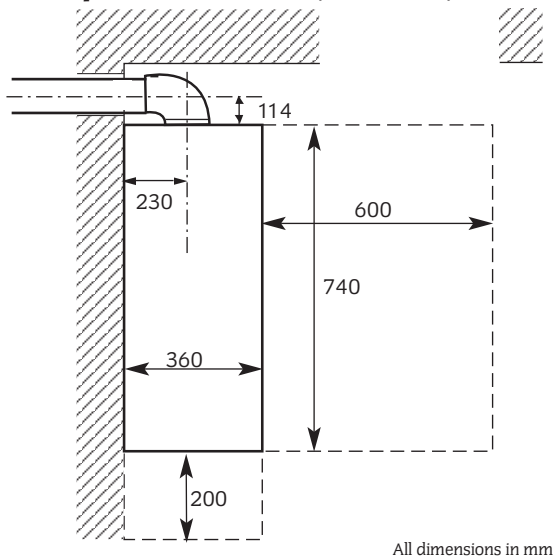

Fig. 5. Unventilated compartment clearances

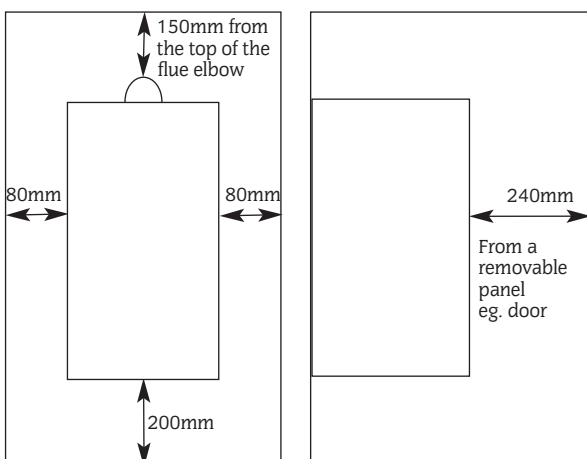

Fig. 6. Side flue opening

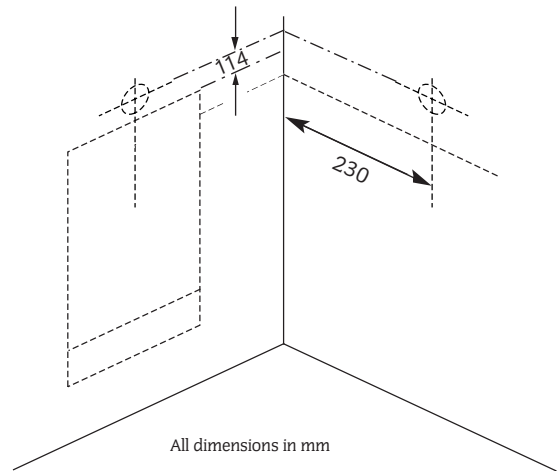
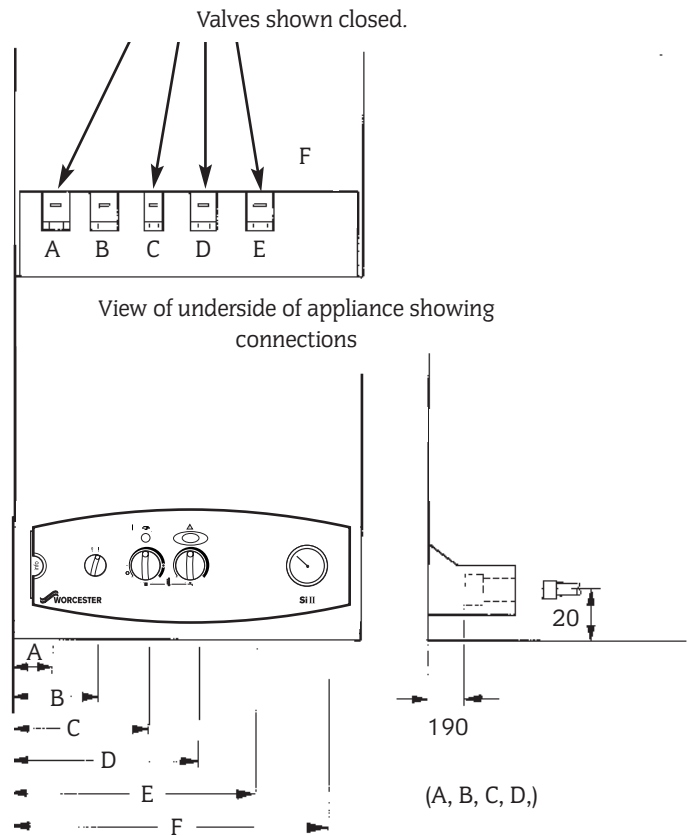

Fig. 7. Pipework connections



	24Si II	28Si II
A CH Flow	= 55	75
B DHW Flow	= 120	140
C Gas	= 185	205
D Cold Water Inlet	= 250	270
E CH Return	= 315	335
F Relief Valve Discharge	= 375	395

All dimensions in mm

4. Siting The Appliance

The appliance may be installed in any room but refer to the requirements of the current IEE Regulations and, in Scotland, the relevant electrical provisions of the Building Regulations with respect to the installation of appliances in rooms containing baths or showers. In Eire refer to the ETCI rules for electrical installations.

Where a room sealed appliance is installed in a room containing a bath or shower, any switch or appliance control using mains electricity must NOT be able to be touched by a person using the bath or shower. The IP rating of the appliance may only allow it to be located in specific 'zones'. Refer to, in GB, Electrical Regulations 16th Edition.

The appliance is NOT suitable for external installation. No special wall protection is required. The wall must be able to support the weight of the appliance. Refer to Table 4.

The specified clearances must be available for installation and servicing. Refer to Table 8 and Fig.3, 4.

The appliance can be installed in a cupboard/compartment to be used for airing clothes providing that the requirements of BS6798 and BS5440 Part 2 are followed. Refer to Section 2.5.

The airing space must be separated from the boiler space by a perforated non-combustible partition. Expanded metal or rigid wire mesh is acceptable provided that the major dimension is less than 13mm. The clearance between the front of the appliance and the cupboard or compartment door should be not less than 75mm.

LPG Installation. Refer to Section 1.8.

5. Flue terminal positions

The flue system must be installed following the requirements of BS5440: 1. In Eire the flue termination must be sited as described in Table 5 of the current edition of IS 813.

Standard horizontal flue kit length is 275 – 725mm with extension kits for flues upto 4m for natural gas and 2.5m for LPG. The terminal must not cause an obstruction or the combustion products a nuisance. Under some conditions the terminal might steam and positions where this might be a nuisance should be avoided. Refer to Fig 8.

If the terminal is less than 2m above a surface to which people have access then a guard must be fitted. The guard must be evenly spaced about the terminal and fixed with plated screws.

A Type K2 guard is available from Tower Flue Components, Vale Rise, Tonbridge, TN9 1TB.

Fig. 8. Siting of the flue terminal.

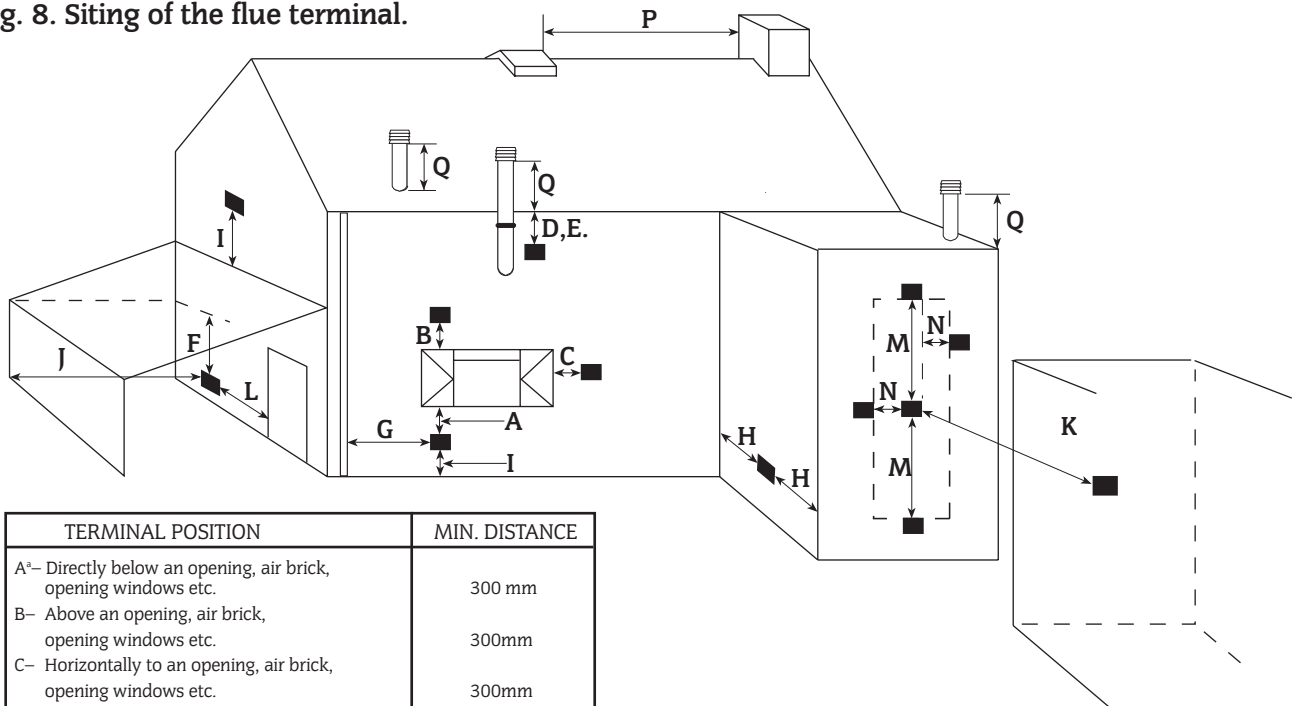

TERMINAL POSITION	MIN. DISTANCE
A ^a - Directly below an opening, air brick, opening windows etc.	300 mm
B- Above an opening, air brick, opening windows etc.	300mm
C- Horizontally to an opening, air brick, opening windows etc.	300mm
D- Below gutters, soil pipes or drain pipes.	75mm
E- Below eaves.	200 mm
F- Below balconies or car port roof. (Lowest point)	200 mm
G- From a vertical drain pipe or soil pipe.	150 mm
H- From an internal or external corner.	300 mm
I- Above ground, roof or balcony level.	300 mm
J- From a surface facing the terminal.	600 mm
K- From a terminal facing the terminal	1200 mm
L- From an opening in a car port (e.g. door window) into dwelling.	1200 mm
M- Vertically from a terminal on the same wall.	1500 mm
N- Horizontally from a terminal on the same wall.	300 mm
O- From the wall on which the terminal is mounted	N/A
P- From a vertical structure on the roof	N/A
Q- Above intersection with roof	N/A

Advice should be taken if the terminal is in close proximity to surfaces which may be of plastic materials ie. car-ports, gutters etc.

NOTE N/A = Not applicable

^aIn addition, the terminal should be not nearer than 150mm (fanned draught) to an opening in the building fabric formed for the purpose of accommodating a built-in element such as a window frame.

6. Air Supply

6.1 A separate vent for combustion air is not required. Refer to BS5440:2.

If the appliance is in a cupboard or compartment then, because of the low casing losses, it is not necessary to have any cooling ventilation for the boiler. Refer to Section 2.5. There must be increased clearance around the appliance to allow the free movement of the air.

Refer to Table 8 and Fig 3, 4 and 5.

6.2 If the appliance is to be fitted in a cupboard or compartments with less clearance than the minimum clearances given in Section 4. (Siting The Appliance) then permanent vents for cooling are required. One at high level and one at low level, either direct to outside air or to a room. Both vents must pass to the same room or be on the same wall to the outside air.

6.4 The minimum free areas required are:

24 kW

POSITION OF AIR VENTS	AIR FROM THE ROOM	AIR DIRECT FROM OUTSIDE
HIGH LEVEL	264cm ²	132cm ²
LOW LEVEL	264cm ²	132cm ²

28 kW

POSITION OF AIR VENTS	AIR FROM THE ROOM	AIR DIRECT FROM OUTSIDE
HIGH LEVEL	307cm ²	154cm ²
LOW LEVEL	307cm ²	154cm ²

Fig. 9. Sealed primary water system.

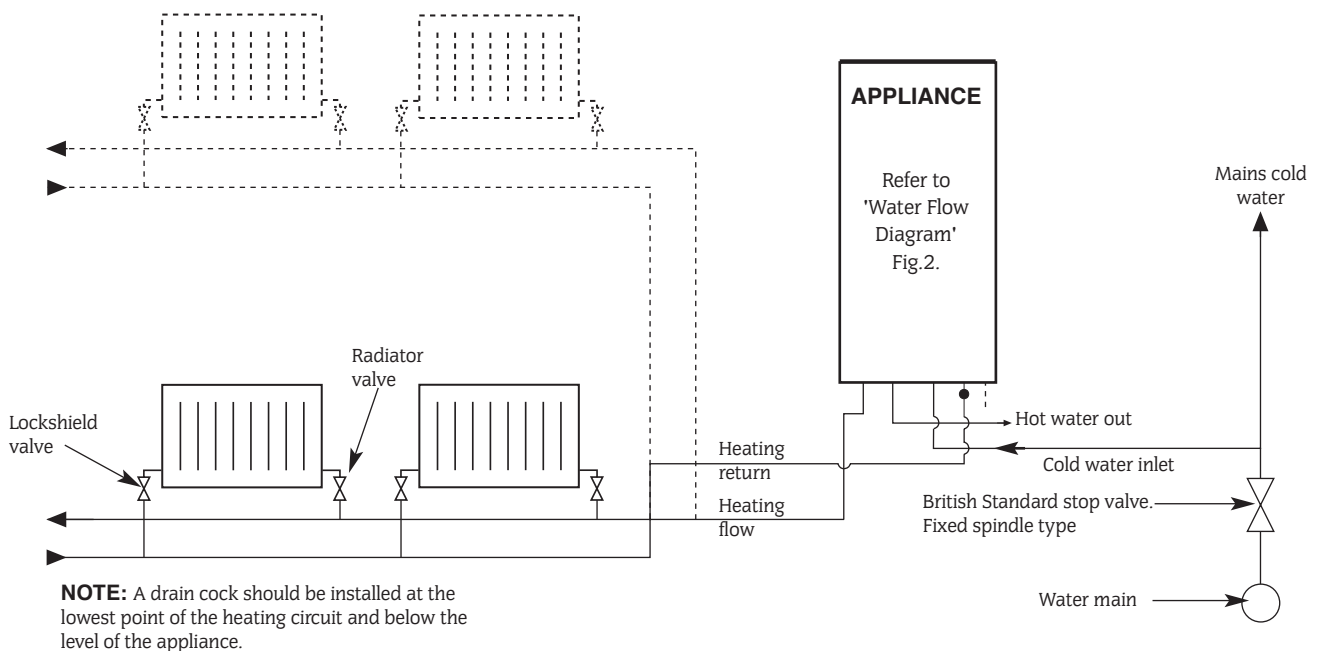

7. Sealed System

The system must comply with requirements of BS6798 and BS5449 and must not be operated without being full of water and correctly pressurised. Refer to Fig 8.

The pressure relief valve will operate at 3 bar. The discharge pipe, of 15mm diameter, must be directed as such that the discharge of water or steam is visible, will not discharge onto the occupants of the premises or cause any damage to the premises, in particular any electrical components or wiring.

The expansion vessel, to BS4814, has a capacity of 8 litres charged to 0.5 bar, which is suitable for a static head of 5 metres. A schraeder type valve allows the pressure to be increased if the static head is greater than 5 metres.

If the expansion vessel fails then it must be replaced with the designated spare part.

Refer to BS 7074:1, BS5449 and Table 9 for a guide to the available system capacity. The maximum system design pressure is 1.5 bar. If the pressure is above 2.65 bar when the appliance is at maximum temperature then an additional expansion vessel must be fitted as near to the appliance as possible in the return pipe. The pressure gauge shows the system pressure.

Fill and pressurise the system through a WRAS approved filling kit. Refer to Fig. 10 and 11. An optional kit is available. Refer to Section 16.

The system and the appliance must be fully vented. Repeated venting loses water from the system, which must be replaced. The make-up connection must be close to the appliance in the heating return pipe through an approved non-return valve.

Refer to current building regulations or Good Practice Guide 302 which lists the requirements.

Plastic Pipes

Plastic pipes must not be directly connected to the boiler. A copper to plastic transition piece should be positioned a minimum of 600mm from the boiler. A plastic pipe with a polymeric barrier should be used.

The connection to the mains water supply must have the approval of the local Water Company.

The pump is set at maximum and should not be adjusted.

All connections in the system must withstand a working pressure of up to 3 bar.

The radiator valves must conform to BS 2767:10 and other valves to BS1010.

Open Vent System

This appliance is NOT suitable for connection to an open vent system.

Fig 10 - System Fill

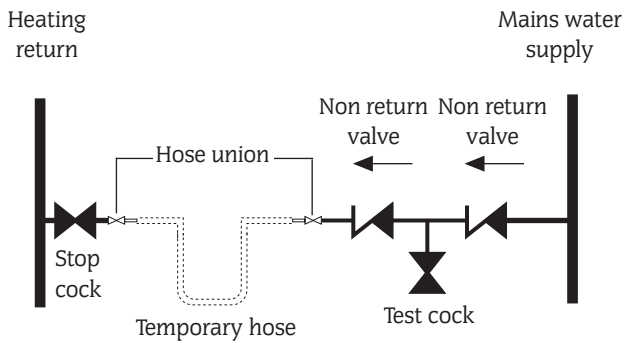
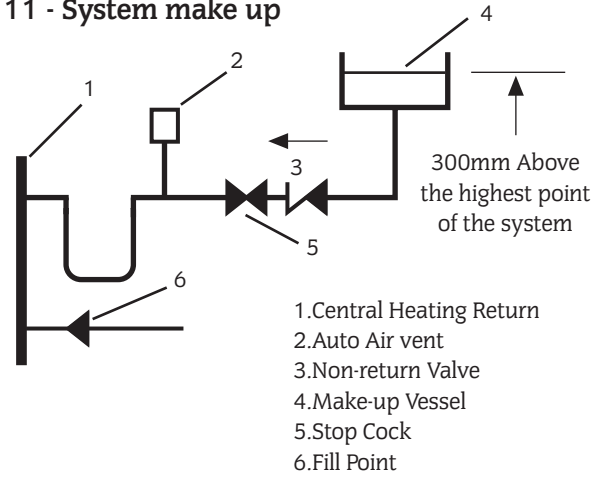

Fig 11 - System make up



8. Domestic Hot Water

It may be necessary to contact the local Water Company before connecting the appliance. Where back-flow prevention devices, including water meters, are fitted the expansion of hot water into cold water main can be prevented. This can result in a pressure build-up that may cause damage to the boiler and household devices such as showers, washing machines etc.

In these cases we recommend that a mini-expansion vessel be fitted adjacent to the boiler in the cold water pipe.

The last 600mm of mains water pipe before the appliance must be in copper.

The domestic hot water circuit of the appliance is suitable for a mains pressure of upto 10bar. A pressure reducing valve must be fitted if necessary.

A mains water supply isolating valve is fitted.

The maximum hot water flow rate is set at the factory to 8 l/min [24Si II] and 10 l/min [28Si II] giving a nominal temperature rise of 40°C with the temperature control at maximum. This rate is equivalent to a Specific Rate of 11.5 l/min [24Si II] and 12.9 l/min [28Si II] at a rise of 30°C. Refer to Table 6. The temperature rise, upto the maximum set by the user, is maintained by the automatic modulation of the heat input.

In winter, when the water temperature is lower it may be necessary to reduce the water flow at the tap or shower to maintain the maximum delivery temperature.

It is recommended that long pipe runs to taps or showers are insulated to prevent the rapid cooling of the water.

Hot and cold taps and mixing valves must be suitable for the available mains pressure.

No anti-syphonage arrangements are necessary for fixed head showers. The hose of a loose-head shower must be fixed so that the shower head cannot get closer than 25mm to the top edge of the bath to prevent its immersion in the water. Alternatively the shower can be fitted with an anti-syphonage device at the flexible hose connection. Thermostatically controlled or pressure balancing shower valves will give extra comfort and guard against extreme temperature.

Hot and cold mains water direct to a bidet is, subject to the approval of the local water company, permissible provided that the bidet is of the overrim flushing type. The outlets must be shrouded and unable to be fitted with a hand-held spray. No anti-syphon arrangements are needed.

LIME SCALE: In areas of temporary hardness [>200 ppm of calcium carbonate] it is suggested that a proprietary scale reducer is fitted in the mains cold water connection to the appliance. Installation of a scale inhibitor assembly must be in accordance with the requirements of the local Water Company. The water hardness can be determined by reference to the local Water Company.

An isolating valve should be fitted to allow servicing.

9. Gas Supply

The appliance requires a maximum of 2.8 m³/h [24Si II], 3.25m³/h [28Si II] of natural gas (G20) or 1.08 m³/h [24Si II], 1.25m³/h [28Si II] of propane (G31). Refer to Table 7.

A natural gas appliance must be connected to a governed meter. The installation and connection of the gas supply to the appliance must be in accordance with BS6891.

The meter (NG) or regulator (LPG) and the pipework to the appliance must be checked, preferably by the gas supplier, to ensure that a dynamic pressure of 20mbar for natural gas or 37mbar for propane is available at the appliance (contact gas supplier if in doubt) equivalent to about 19mbar [NG] or 36mbar [LPG] respectively at the gas valve inlet pressure connection and that the gas flow is adequate for all the installed gas appliances operating together.

10. Electrical

Mains supply: 230V ~ 50 Hz 180watts.

External fuse 3A to BS1362. Internal fuses F1-T2A, F2-TI.25A (20mm). Spare internal fuses are supplied with the appliance.

The mains cable must be 0.75mm² (24x0.20 mm) to BS6500 - Table 16 and must be connected to the terminal ST2 marked L (red or brown lead), N (black or blue lead) and the Earth stud (green or green/yellow lead) and secured with the cable clamp. The Earth lead must still be slack when the other leads are taut. Refer to Fig 14 and 15.

The appliance must be earthed.

The wiring between the appliance and the electrical supply shall comply with current IEE wiring regulations (and any local regulations which apply) for fixed wiring to a stationary appliance.

NB. It must be possible to completely isolate the appliance with at least 3mm contact separation in both poles.

A room thermostat or externally mounted programmer must be suitable for mains voltage operation. The leads must be securely fixed in the cable clamps (see Fig. 35)

A fascia mounted digital programmer or mechanical timer or receiver for wireless programmable room thermostat is available as an optional extra. Instructions are supplied with the product.

On very rare occasions it may be necessary to fit an external frost thermostat to protect remote parts of the system. In this case refer to the WHS Technical Department for information, Tel: 08705 266241.

Fig. 12. Wiring diagram.

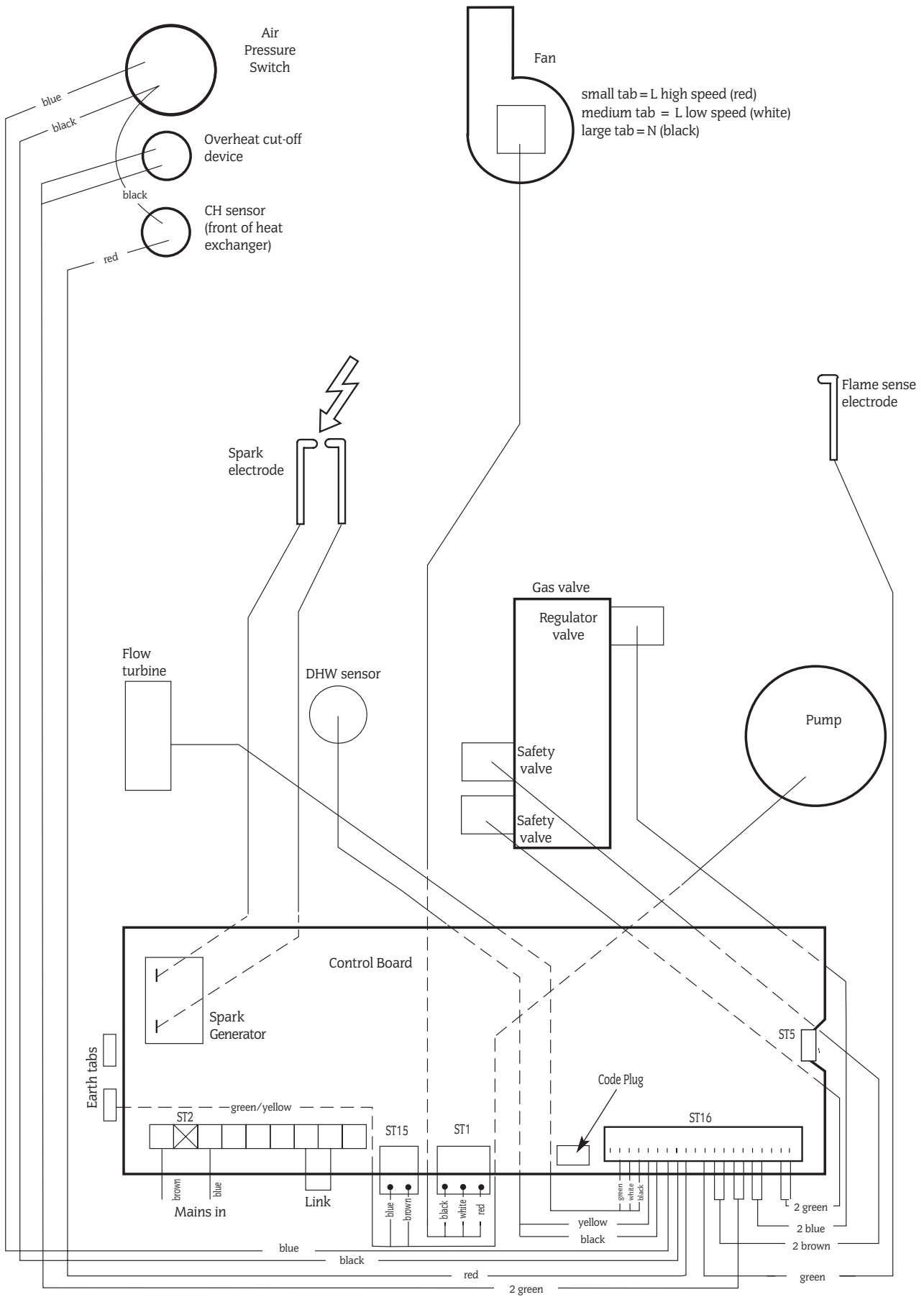

Fig. 13. Functional flow diagram.

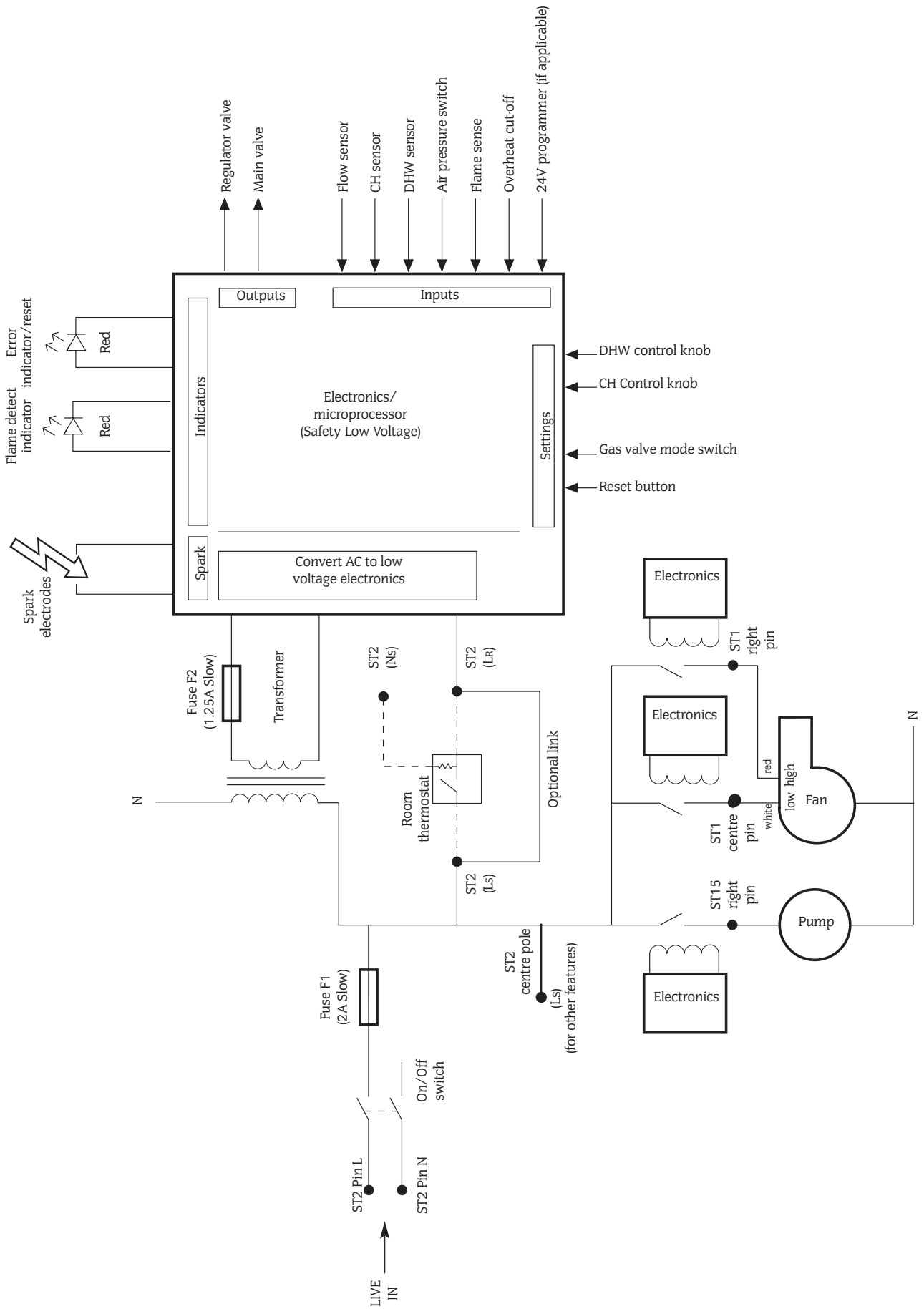
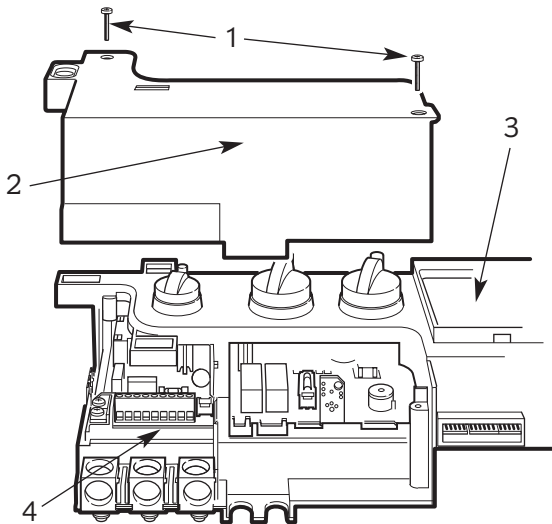
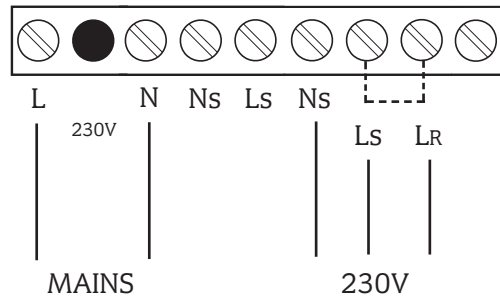

Fig. 14. Access to internal fuses and electrical connections.



- 1. Connection cover fixing screws
- 2. Connection cover
- 3. Control panel
- 4. Connections

Fig. 15 . Mains electricity connections.



11. Installing The Appliance

NOTE: READ THIS SECTION FULLY BEFORE COMMENCING THE INSTALLATION.

11.1 General

The appliance is only suitable for fitting to a sealed system. The flue must be installed as specified in BS5440:1 and the current Building Regulations.

11.2 Unpacking

Remove the appliance from its packaging and check the contents against the packing list. Unscrew the service connections and remove the wall mounting assembly.

NOTE: The wall mounting assembly can be removed from the carton **without** having to remove the boiler.

11.3 Site Preparation

Check that the correct position for the appliance has been chosen. Refer to Section 4 and Table 8.

Check that the wall is flat and will support the weight of the appliance. Refer to Table 4.

11.4 Fixing Holes and Flue Opening

Hold the wall mounting assembly or template against the wall. Check that the assembly or template is level. Mark the position of the fixing holes and the flue opening. Refer to Fig 16.

The diamond cut-out indicates the centreline of the appliance. Mark the centrelines of the pipe connections to aid the pre-plumbing of the system pipework.

Pre-plumbing is not recommended if no movement in the pipes is available.

Check the position of the fixing points and flue opening before drilling the fixing holes 60mm deep for the No. 12 size plugs and cutting the flue duct hole at 110mm diameter [150mm diameter for internally fitted flues].

11.5 Wall Mounting and Manifold Assembly

Fit the plugs and insert the bottom screws.

Check that all service valves are closed.

Offer the assembly to the wall utilising the keyhole slots on the manifold assembly and fix to the wall. Refer to Fig 16 and 17.

Check that the assembly is properly aligned before tightening the screws.

11.6 Gas and Water Pipes

Remove the gas cock and fix the appropriate fitting to connect the inlet pipe and refit. Refer Fig 17.

If it is necessary for any of the pipes to run up the back of the appliance then they must be arranged to pass behind the expansion vessel. Refer to Fig 3. Pipework must not run horizontally within the limits of the casing.

It is important that the pipes are not fixed near the appliance using clips that put a strain on the connections.

benchmark Before the appliance is fitted to the wall thoroughly flush the system and mains water supply.

Fig. 16. Wall mounting assembly

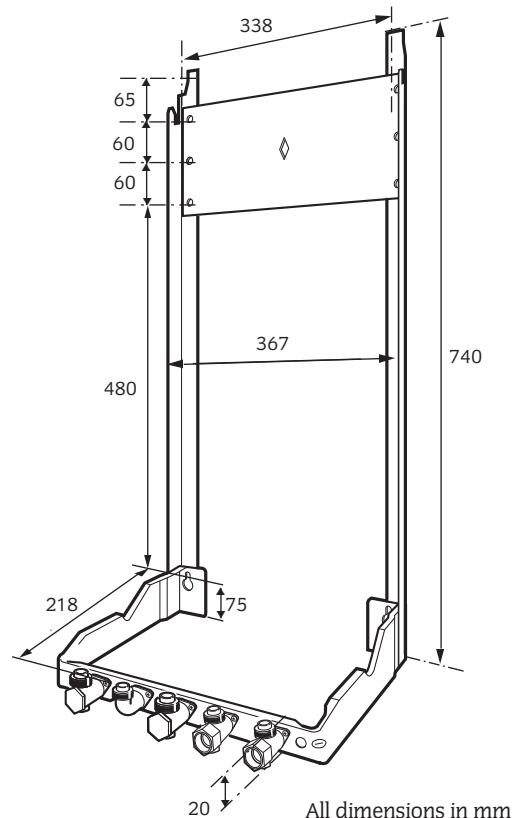
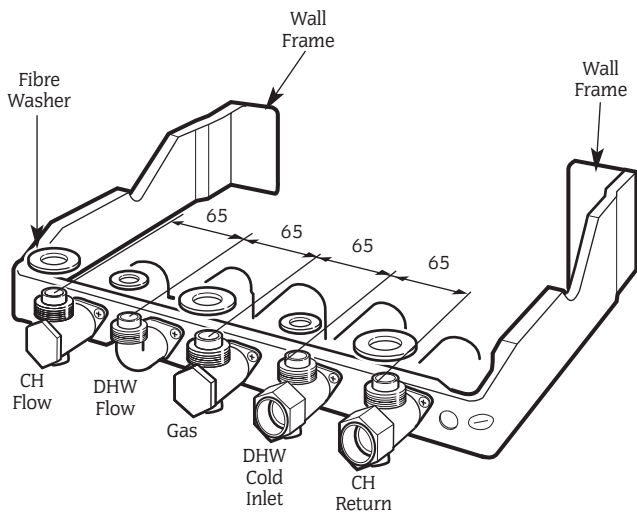
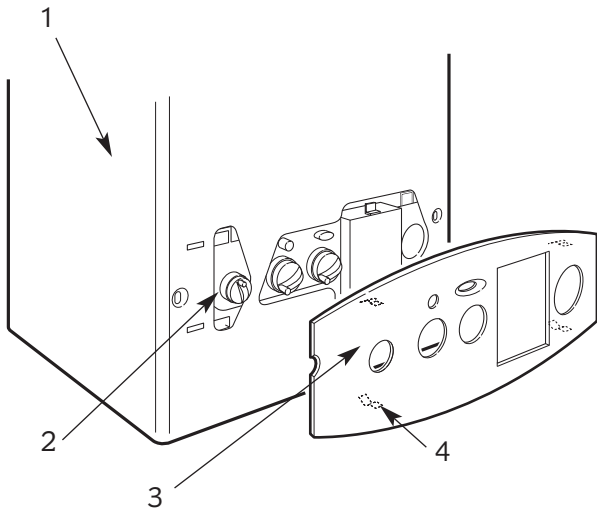

Fig. 17 . Manifold assembly



All dimensions in mm

Fig. 18 . Facia cover



1. Appliance
2. Controls
3. Facia cover
4. Facia cover clips (4)

11.7 Install the Boiler

Pull off the clip on facia cover and remove the cabinet by unscrewing the two fixing screws, releasing the sides and lifting from the top location.

Check that the gas and water valves are closed. Refer to Fig 17. Fit the new seals, in the hardware pack, to the service valves on the manifold.

Fig. 19 . Wall mounting frame

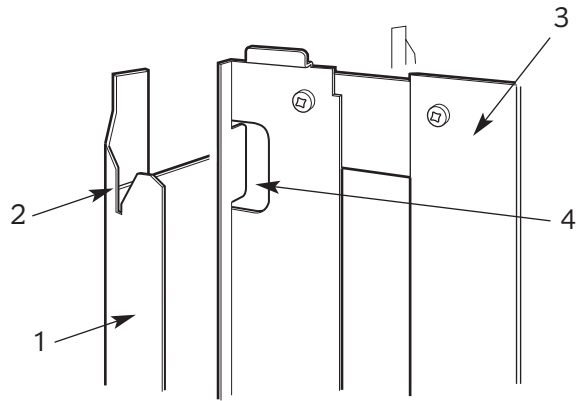

1. Wall mounting frame
2. Hanging bracket
3. Appliance
4. Support hook

Lift the appliance to the wall, engage in the top support and lower onto the manifold assembly. Tighten the gas and water connections.

Fit a discharge pipe to the relief valve leading it away from any electrics or where it might be a hazard. Lower the facia to gain access. The pipe must not be less than 15mm in diameter and must run continuously downward outside the appliance. Refer to Fig 20.

Fig. 20 . Relief valve drain connection

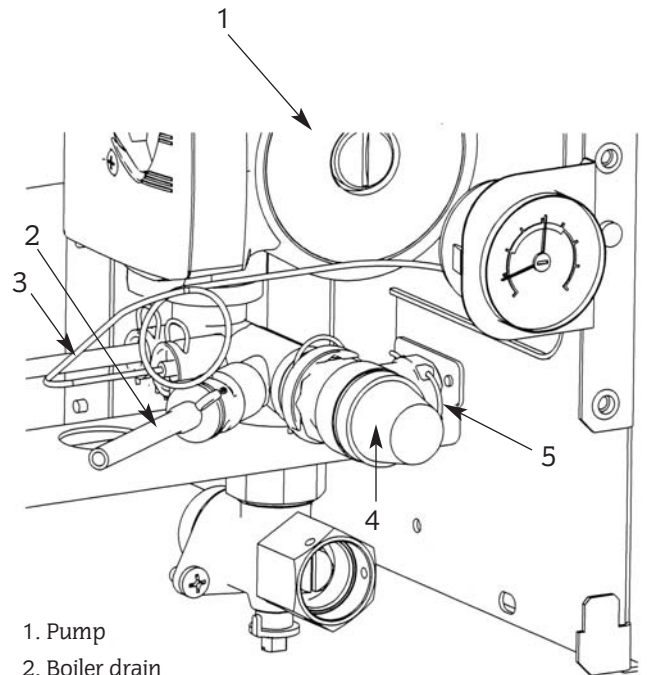

1. Pump
2. Boiler drain
3. Pressure gauge capillary
4. Relief valve
5. Relief valve drain connection (push fit)

Fig. 21. Inner case and facia fixing

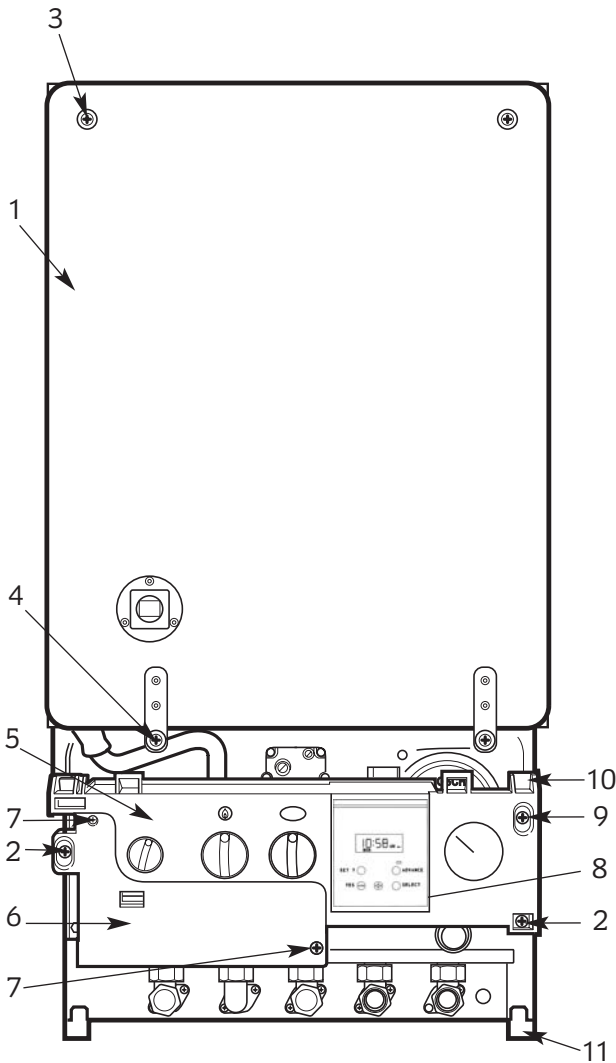

1. Inner casing cover
2. Cabinet fixing screws (4)
3. Inner casing cover fixing screws (2)
4. Inner casing cover fixing screws (2)
5. Facia control panel
6. Controls connector cover
7. Controls connector cover fixing screws (2)
8. Programmer (optional)
9. Facia control panel fixing screw
10. Top support lug (2)
11. Bottom support lug (2)

11.8 Air and Flue Duct Preparation

The method of installation of the flue system may be varied to suit the actual site conditions. The instructions for connecting and fixing the ducts must, however, be strictly followed.

Remove all packing material from the flue components.

RESTRICTOR RINGS		
Flue length	24Si II	28Si II
Horizontal up to 725mm	76mm	78mm
Horizontal above 725mm	None	None
LPG Horizontal up to 725mm	76mm	77mm
Vertical terminal length only 1200mm	78mm	82mm
Vertical flue greater than 1200mm	None	None

Fig. 22. Flue spigot and restrictor

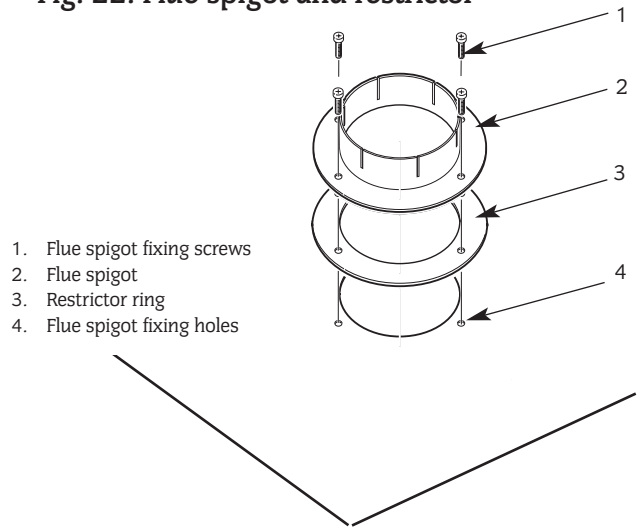
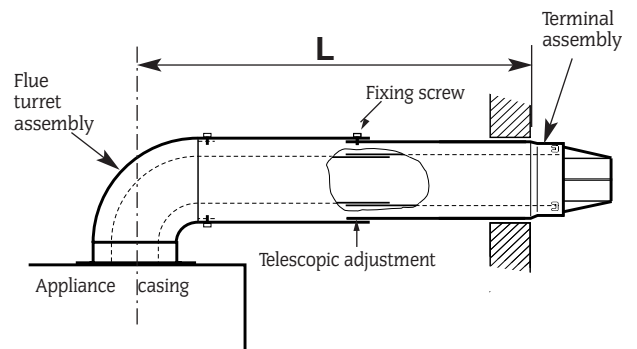

Fig. 23. Standard flue assembly



Fit the flue restrictor ring by unscrewing the flue spigot from the boiler. Refer to Fig. 22.

The standard telescopic flue assembly is suitable (without cutting) for flues from 425mm up to 725mm measured from the centre-line of the boiler flue outlet to the outer face of the wall. Refer to Fig.23.

The minimum length of the standard flue, after cutting is 275mm. If L is greater than 725mm then extension duct kit/s will be required - each kit extends the flue by 750mm up to a maximum of 4000 mm for natural gas boilers and 2500mm for LPG. See table below.

EXTENSION	MAXIMUM FLUE LENGTH mm
1	1475
2	2225
3	2975
4	3725
5	4000

11.9 Measure and Cut the Ducts.

General: Cut the ducts as necessary, ensuring that the cuts are square and free from burrs. Always check the dimensions before cutting.

Measure the distance L. Refer to Fig. 23, 24, 25 and 26.

The standard flue can be telescopically adjusted to any length between 425mm and 725mm measured from the centre of the turret without the need to cut the ducts.

Fix the flue assembly together using the self-tapping screws provided. Refer to Fig. 23.

It will only be necessary to cut the standard assembly if L is less than 425mm. Cut the flue turret assembly and the terminal assembly by the same amount eg. if L=350 – remove 75mm (425-350) from each assembly.

Fig. 24. Extension duct

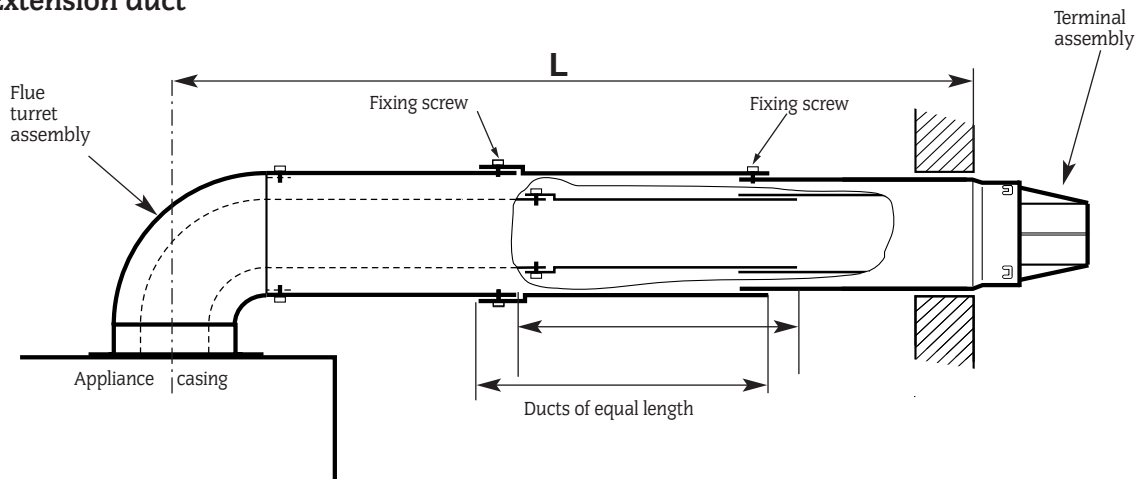

Fig. 25. Flue duct length - side

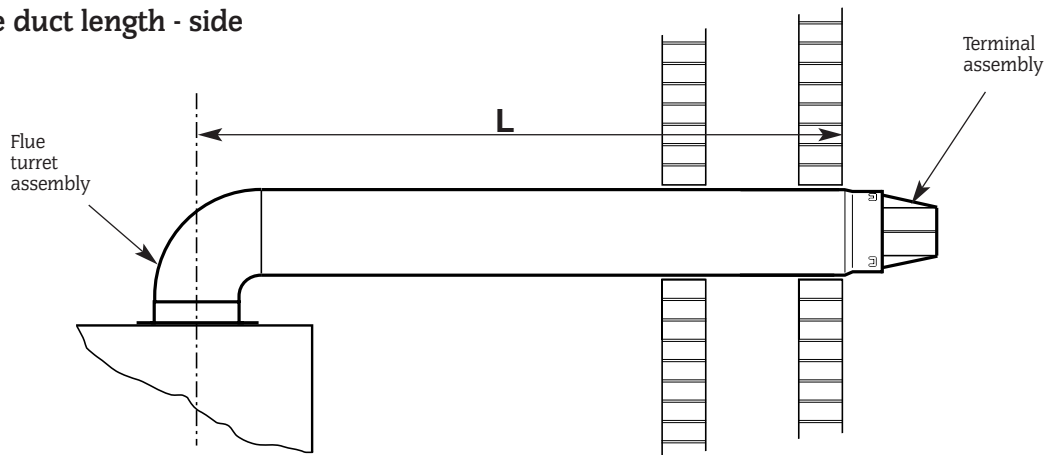
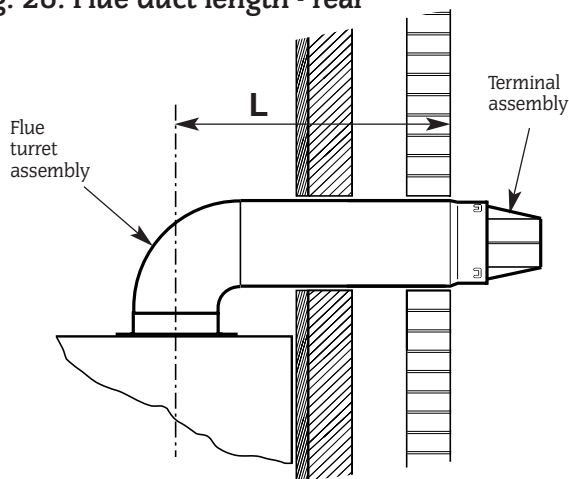

Fig. 26. Flue duct length - rear



It is not necessary to cut the ducts

If L is between	1175 - 1475mm	(1 extension)
	1925 - 2225mm	(2 extension)
	*2675 - 2975mm	(3 extension)
	3425 - 3725mm	(4 extension)

(* Maximum length 2500mm for LPG boilers)

It will be necessary to cut the ducts

If L is between	725 - 1175mm	(1 extension)
	1475 - 1925mm	(2 extension)
	*2225 - 2675mm	(3 extension)
	2975 - 3425mm	(4 extension)
	3725 - 4000mm	(5 extension)

(* Maximum length 2500mm for LPG boilers)

It is necessary to shorten the assembly by cutting the first extension duct assembly eg. $L = 1000\text{mm}$ - remove 175mm from the air and flue ducts ($1175 - 1000 = 175\text{mm}$).

NOTE: Extension duct measurements do not include the socketed end. Unless specifically instructed the socketed end must not be removed.

Fix the flue ducts together before fixing the surrounding air duct, the cut ducts fit into the terminal assembly.

11.10 Fitting the Flue Assembly with Access to the Terminal.

Prepare the flue duct assembly as described in Section 11.8. Apply the plastic tape to the air duct to be in contact with the external brickwork.

From inside push the assembly through the wall. Align the flue turret and push fully onto the spigot on the appliance. Tighten the clamping ring. Refer to Fig.27.

Make good the internal wall face and the external brickwork or rendering.

11.11 Fitting of the Flue Assembly without access to the Terminal.

The rubber gasket kit is available as a spare part.

NOTE: A larger diameter opening in the wall is required. Refer to Table 2.

Fig. 27 . Flue Turret Fixing

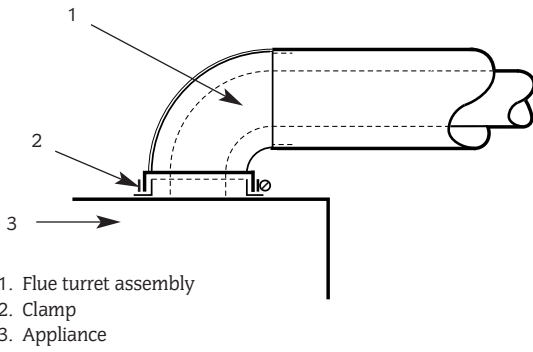

Fig. 28 . Terminal assembly for internal fitting of the flue.

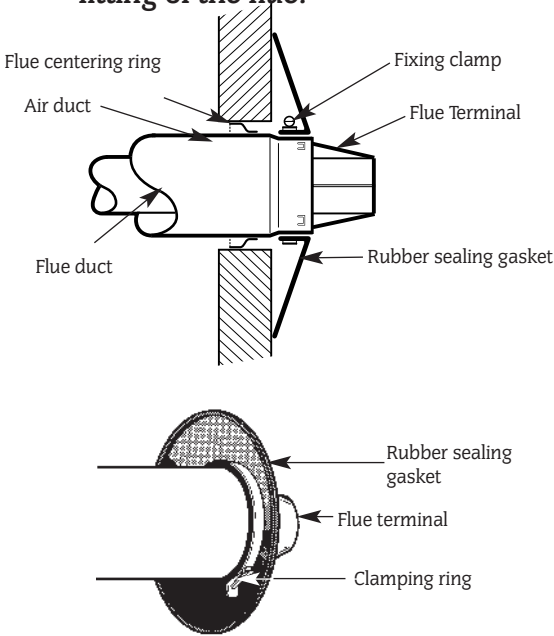
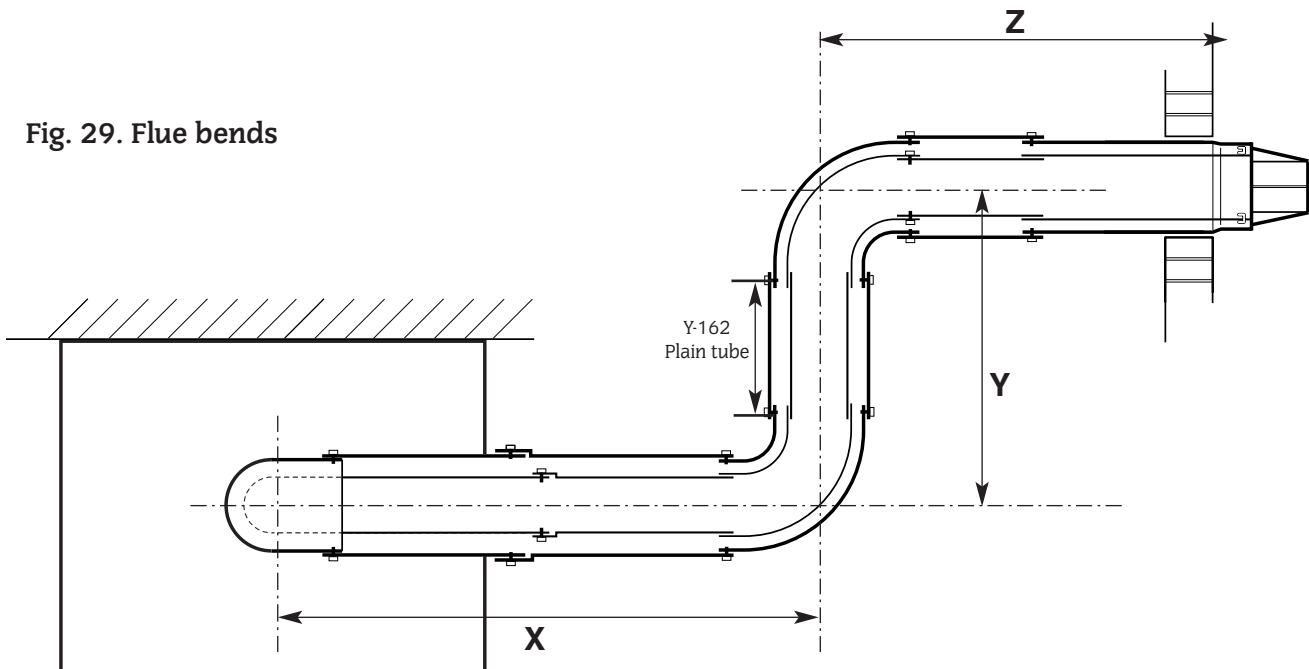

Fig. 29. Flue bends



Prepare the flue assembly as described in Section 11.8.

Fit the rubber sealing gasket centrally onto the terminal assembly and tighten the clamp. Refer to Fig. 28.

Apply the plastic tape to the air duct to be in contact with the external brickwork.

From inside push the assembly through the wall so that the gasket flange is against the outer face. Refer to Fig. 28.

It may be necessary to adjust the legs of the flue centering ring. Align the flue turret and push fully onto the socket on the appliance. Tighten the clamping ring. Refer to Fig. 27.

Seal the gap around the duct at the inner wall face with the flexible seal provided and make good.

11.12 Flue Bends.

90° and 45° bends are available. A maximum of two bends may be used in addition to the first bend on the flue turret.

A 90° bend is equivalent to 750mm of straight duct.

A 45° bend is equivalent to 375mm of straight duct.

A maximum flue assembly of 3250mm for natural gas and 1750mm for LPG is possible with 1 X 90° bend and 2500mm natural gas and 1000mm for LPG with 2 X 90° bends.

Measure the lengths X,Y and Z. Refer to Fig.29.

The maximum value of X using the turret assembly only is 506mm.

Reduce the ducts to the appropriate length eg. X = 406mm, cut 100mm from the air duct and 120mm (to cover the entry into the 45° or 90° elbow) from the flue duct. Refer to Fig.30.

NOTE: The flue system ducts between the elbows, dimension Y, requires the socketed ends (of the first extension if two or more are used) to be removed and the air and flue tubes to be cut to the same length.

Cut the ducts to a length Y – 162mm. Refer to Fig.29.

The final section, dimension Z, of the flue system must include a section of plain duct assembly eg. an extension assembly with the sockets removed. Reduce the final section, including the terminal assembly, by the appropriate amount eg:

Air duct Z - 81mm and the flue duct Z – 51mm. Refer to Fig.29.

If Z is less than 425mm it will be necessary to cut the air and flue ducts of the extension to a plain length of 100mm and reduce the length of the terminal assembly eg. Z = 350mm - remove 75mm from the terminal assembly.

If Z is between 425 - 725mm it is not necessary to cut the terminal assembly or use a second extension duct as the length can be set telescopically.

If Z is greater than 725mm then two extension duct assemblies will be required, the first assembly being cut to length as plain tubes.

If more than two extension ducts are needed in any section to achieve the required length then the final section of the assembly must not be less than 275mm without cutting the terminal assembly.

NOTE: The flue duct of the final extension must be 30mm longer than the air duct.

Each section must be connected to the previous section of the flue bend by fixing the flue ducts together and then similarly fixing the air ducts which engage the elbows.

Fit the assembly as described in Section 11.9, 11.10 as appropriate.

Make good the internal and external brickwork or rendering.

11.13 Vertical Adapter for Horizontal Flues

An adapter is available for an initial short section of vertical flue. Refer to Fig. 31.

Measure and cut the flue as described in Section 11.11.

The first, vertical, section (equivalent to dimension X) is measured from the top of the boiler casing. Cut the vertical section of the extension duct to 167mm less than the measured distance. Do not remove the socketed ends.

The minimum measured distance is 167mm.

Seal the air duct to the spigot using silicone sealant.

11.14 Completion of the Installation

Check that all the gas and water connections on the manifold have been tightened.

Undo the two screws and remove the connections cover panel. Refer to Fig 32.

Fig. 30 - Elbow to Flue Turret Assembly.

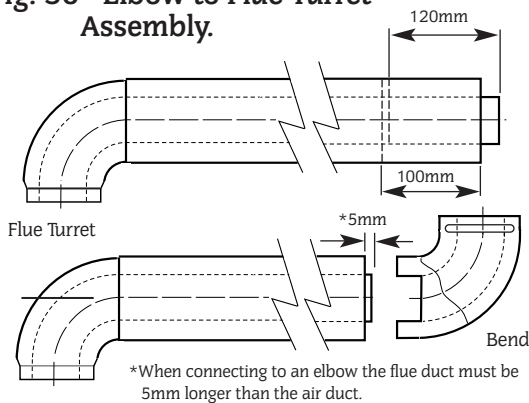
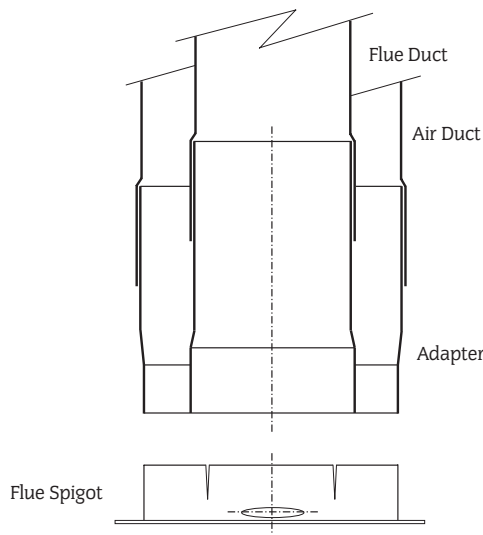

Fig. 31 Vertical Adapter.



Connect the mains supply lead to the appliance and secure in the cable clamp. Make sure that the lead is isolated before connection. Refer to Section 10.

Check that there is sufficient loose lead to allow the release of the fascia panel assembly and that the earth lead of the mains supply is longer than the live and neutral leads.

Fit the fascia-mounted clock or programmer. Full instructions are sent with the control. Refer to Fig 33 and 34.

Connect any external controls ensuring that the leads pass through the appropriate cable clamp. Refer to Section 10 and Fig 35 and 36.

Test for gas soundness as described in BS6891.

If the appliance is not to be commissioned immediately, replace the connection cover panel and the cabinet.

Check that the gas and electricity services have been turned off.

Fig. 32. Facia connections cover

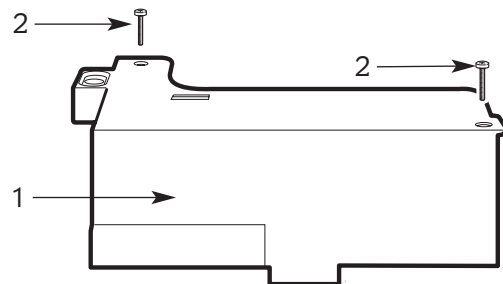

1. Controls connector cover
2. Controls connector cover fixing screws (2)

Fig. 33. Programmer connection

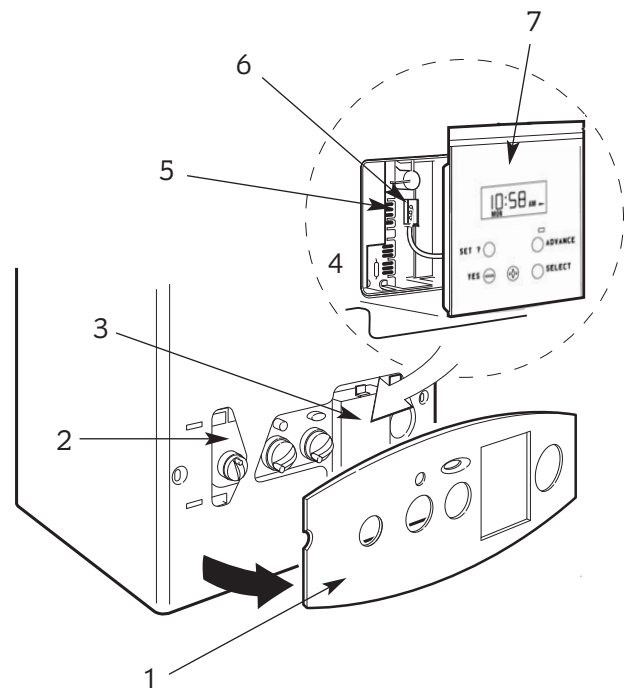

1. Facia (gently pull forward to un-clip and remove)
2. Control panel (boiler outer casing in place)
3. Programmer cover (un-clip to remove. See Fig. 34)
4. Programmer location in detail
5. Programmer connections (See Fig. 34)
6. Programmer connector plug
7. Programmer

Fig. 34. Programmer cover

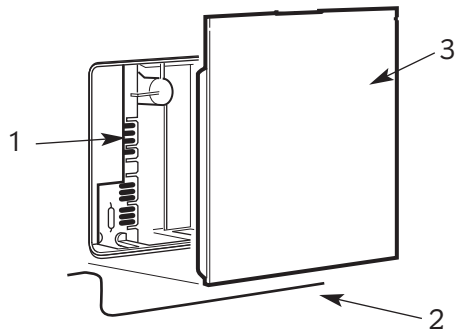

1. Programmer connections
2. Boiler outer casing
3. Cover panel

Fig 36 - Mains Voltage External Controls Connections

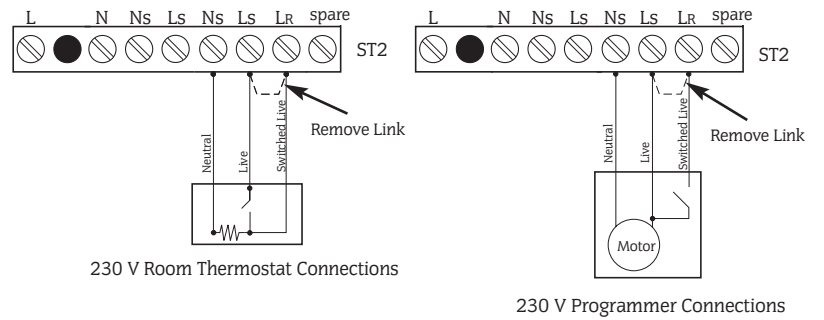

230 V room thermostat and Programmer Connections

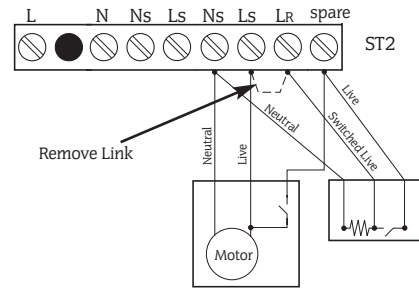
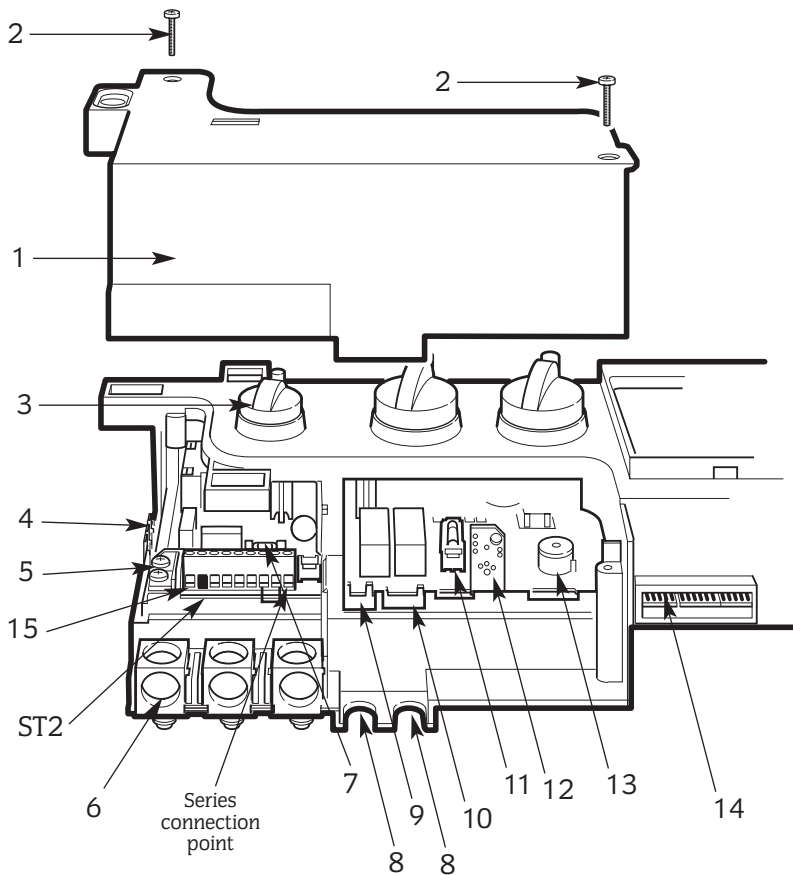

Fig. 35. Facia connections



1. Controls connector cover
2. Controls connector cover fixing screws (2)
3. Facia control panel
4. Earth connection (tags)
5. Earth connection (screws)
6. Cable clamp
7. Fuse F1 2A (slow)
8. Cable clamp
9. ST15 Pump
10. ST1 Fan
11. Fuse F2 1.25A (slow)
12. Code plug
13. Commissioning switch (gas valve mode switch)
14. Internal controls connectors
15. Mains and external controls connectors (230 Volt)

12. Commissioning The Appliance

(benchmark) Water Treatment: For optimum performance after installation, this boiler and its associated central heating system should be flushed in accordance with the guidelines given in BS7593: 1992 – Treatment of water in domestic hot water heating systems. Full instructions are supplied with proprietary cleansers sold for this purpose. If an inhibitor is to be used after flushing, it should be used in accordance with the manufacturers instructions. Remove all system cleanser before adding any inhibitor. Suitable flushing agents and inhibitors are available from Betz Dearborn on 0151 4209563 or Fernox on 01799 550811.

12.1 System Set up

Remove the cabinet by pulling off the clip-on fascia cover. Unscrew the two fixing screws, release the sides and lift from the top location.

Check that the electrical supply and the gas supply to the appliance are turned off and that all the water connections throughout the system are tight.

Open the system valves at the appliance. Refer to Fig 17.

Open all the radiator valves. Remove the automatic air vent cap. Refer to Fig 37.

Fig. 37. Automatic air vent and combustion test point

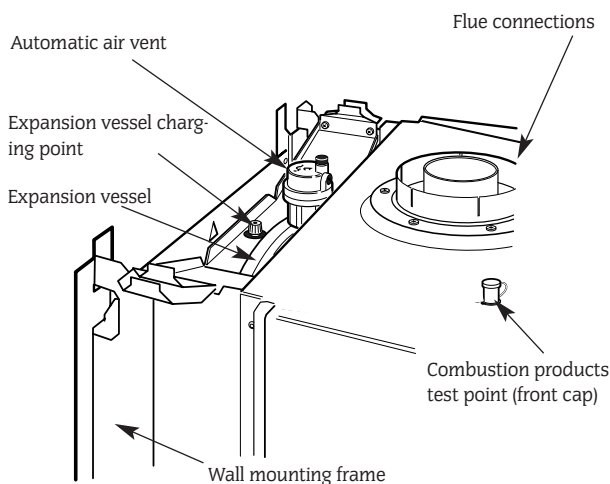

Fill the system through an external WRAS approved filling loop or Worcester Filling Link and Key optional extra, Part N^o: 7 716 192 281. Refer to Section 7, Sealed System.

Vent each radiator in turn. The automatic air vent, cap removed, will vent the appliance. Refer to Fig 37.

It is very important that the appliance and system are fully vented and that all air pockets are removed.

Remove the cap from the pump and turn the shaft about half a turn. Replace the cap. Refer to Fig 38.

Check that the pressure relief valve operates by turning the knob anti-clockwise until it releases. Lower the fascia to gain access to the relief valve. Refer to Fig 20. Water should be expelled from the discharge pipe. Refer also to Fig 54.

The appliance [as despatched] can accommodate a system volume of 100 litres. Refer to BS7074 Part 1, BS5449 and Table 8. If the system volume is greater than an extra vessel must be fitted as close as possible to the appliance central heating return connection and pressurised to the same figure as the integral vessel.

12.2 Set the Expansion Vessel Pressure

The charge pressure of the expansion vessel as despatched is 0.5bar, which is equivalent to a static head of 5m. The charge pressure must not be less than the static head at the point of connection. A Schraeder type valve is fitted to the

Fig. 38. Pump venting.

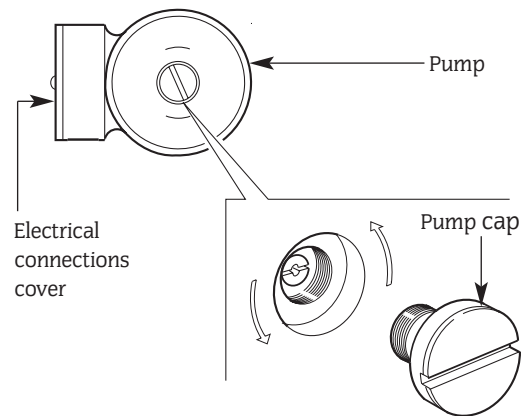

expansion vessel to allow the charge pressure to be increased if necessary. Refer to Fig 37.

The expansion vessel must be charged to 0.35bar less than the initial system design pressure.

Note: 1bar = 10.2m of water.

12.3 Set the System Pressure

Fill the system until the pressure gauge is at 2.5bar and check for leaks. Release water from the system using the relief valve test knob until the required system pressure is obtained, upto a maximum of 1.5bar. Set the pointer on the pressure gauge to record the set system pressure.

If the pressure indicated on the gauge is greater than 2.65bar when operating at the maximum central heating temperature then an extra expansion vessel must be fitted to the system as close as possible to the appliance central heating return connection.

12.4 Clock/Programmer

The controls fitted to the appliance should be set up at this stage. Refer to the instructions sent with the control.

12.5 Checking the Burner Pressure

Check that the gas and electricity supplies are turned off.

Connect pressure gauges to the gas valve to measure the inlet and burner pressures. Refer to Fig 39.

The appliance is fully set up in the factory and no adjustment should be necessary.

Fig. 39. Gas valve.

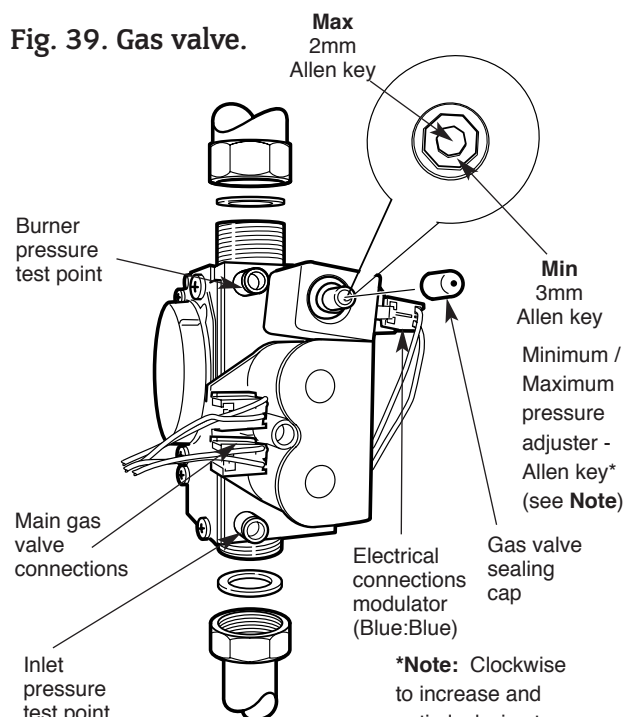

Unscrew and remove the control connector cover to display the mode switch. Refer to Fig 32.

Check that all the radiator valves are open. Check that the system is fully vented, pressurised and set to the required pressure as indicated on the gauge.

Set the temperature control knobs to maximum and the clock/programmer to operate continuously.

Fully open a hot tap.

Fig.40. Mode adjustment

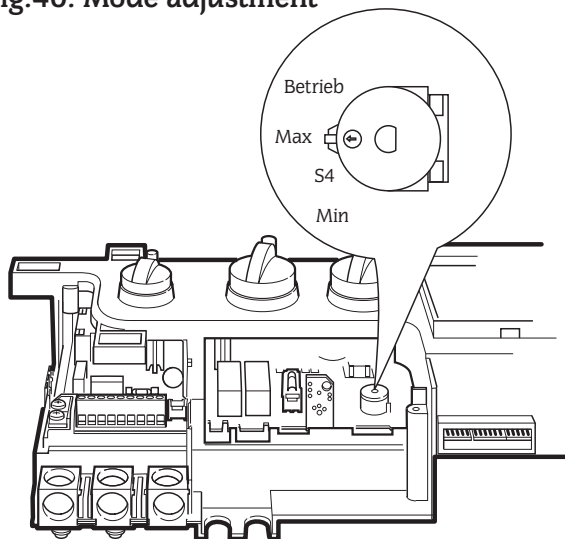

Set the mode switch to MAX. Refer to Fig 40.

Turn on the gas and electricity supplies.

A continuous spark will occur until the burner is alight and sensed by the control circuit. The burner will remain at its maximum domestic hot water pressure for 1 minute. Refer to Table 1. It should not be necessary for the gas valve to be adjusted.

Note: The burner pressure is factory set and if, after checking that the dynamic (working) supply pressure is sufficient i.e. 19.0mb approx. [NG] or 36mbar approx. [LPG] at the gas valve inlet pressure test point, the correct pressure cannot be obtained then The Worcester Service Department should be contacted.

If the appliance does not light then check that it is not in the 'lock-out' state by gently pressing the reset button for 5 seconds. Refer to Fig 41.

Set the mode switch to Normal.

Turn off the hot tap.

The burner pressure will drop to the minimum setting and will ramp up to the maximum central heating pressure appropriate to the appliance and the gas. Refer to Table 1.

Set the mode switch to MIN.

The burner pressure will drop to the minimum burner pressure appropriate to the appliance and the gas for both the central heating and domestic hot water modes. Refer to Table 1.

Test for gas soundness at the joint between the burner and the gas valve with leak detection fluid.

Set the mode switch back to Normal.

Turn the electricity supply off and then back on to reset the controls.

Replace the controls connector panel.

12.6 Operation of the appliance

Domestic Hot Water

Turn the central heating temperature control knob fully anti-clockwise.

Open a hot tap near the appliance. The burner will light and go to the maximum burner pressure appropriate to the appliance and the gas. Refer to Table 1. Gradually close the tap and check that the burner pressure falls. Fully open the tap and check that the pressure rises. Close the tap and check that the burner goes out.

The fan and pump may continue running until the appliance has cooled to a pre-set temperature.

12.7 Central Heating

Check that all the radiator valves are open.

Check that the system is fully vented, pressurised and set to the required pressure as indicated on the gauge.

Check that the clock/programmer is set to operate continuously.

Set the room thermostat and the central heating temperature control to maximum.

The burner will light and the appliance will modulate its output from minimum to maximum over a period of about two minutes.

Check that all the radiators are heating up evenly. Shut down all but one of the radiators and observe the burner pressure fall. Open all the radiators and check that the burner pressure rises.

Balance the system to give the required temperature differential. Refer to Table 3.

Set the room thermostat to minimum and check that the burner goes out.

Reset the room thermostat to maximum and the burner will re-light and follow the normal operating procedure.

12.8 Check flame failure device

Turn off the gas service cock. The burner will go out but sparking from the electrode will continue for 10 seconds when the appliance will 'lock-out'. After 60 seconds **carefully** open the gas service cock, press the reset button and observe the burner re-light and follow the normal sequence of operation. Refer to Fig 17 and 41.

Turn off the gas service cock and the electricity supply to the appliance.

(benchmark) Drain the system while the appliance is hot.

Refill, vent and re-pressurise the system as described in Section 12.1 preceding, adding, if necessary, a suitable proprietary inhibitor.

Further information is available from Betz Dearborn on 0151 4209563 or Fernox on 01799 550811.

12.9 Domestic Hot Water and Central Heating

Set all controls to maximum. Turn on the electricity supply to the appliance and open the gas service cock at the appliance. The burner will light and heat will pass into the system.

Turn on a hot tap and check that hot water is soon discharged from the tap. Close the tap and the burner will go off. The appliance will then return to the central heating mode and automatically balance with the system requirements.

12.10 Completion of Commissioning

Turn off the appliance and disconnect the pressure gauge and tighten the test point screw.

Restart the appliance and check for gas soundness around the test point screw.

Refit the cabinet.

If the appliance is to be passed over to the user immediately then set the controls to the users requirements.

If the appliance is to be left inoperative in frosty conditions then set the programmer, if fitted, to off. Do not turn the electricity or gas supplies off. The appliance will operate under the control of the integral frost protection facility.

If there is any possibility of the appliance being left totally unused in freezing conditions then switch off the gas and electricity and drain the appliance and the system.

The appliance must be fully re-commissioned when it is returned to service. The venting of the appliance is very important.

13. Handover

Fig. 41. Facia controls

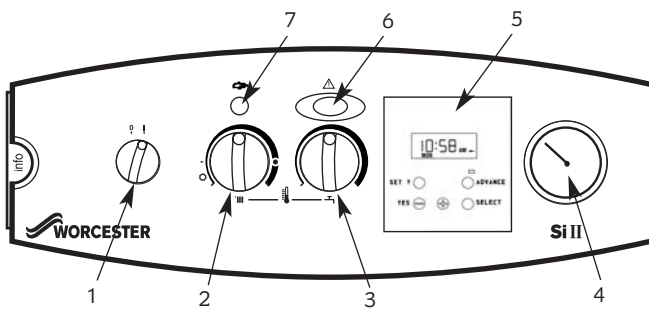

- | | |
|----------------------------|--|
| 1. Mains On/Off control | 5. Optional programmer |
| 2. CH temperature control | 6. Lockout indicator lamp and reset button |
| 3. DHW temperature control | 7. Burner indicator lamp |
| 4. System pressure gauge | |

benchmark Hand over the User Booklet and the completed Benchmark Checklist.

Explain how to operate the appliance safely and efficiently. Tell the user what to do if the appliance is not to be used in very cold conditions.

Tell the user what to do if the system pressure falls.

Explain that regular servicing will maintain the safe and efficient operation and extend the life of the appliance. WHS or their agent can offer a comprehensive maintenance contract.

Tell the user that any work on the appliance must only be carried-out by a competent, registered, person (CORGI in GB).

14. Inspection And Service

14.1

To ensure continued efficient operation of the appliance it must be checked at regular intervals. The frequency of servicing will depend upon the particular installation conditions and usage, but once per year should generally be adequate. The extent of the service required by the appliance is determined by the operating condition of the appliance when tested by fully qualified engineers.

Any service work must be carried out by competent registered engineers (CORGI in GB).

14.2 Inspection

Check that the terminal and the terminal guard, if fitted, are clear and undamaged.

If the appliance is in a compartment or cupboard check that the specified service space around the appliance is clear. Refer to Table 8. Check all the joints and connections in the system and remake any that show signs of leakage. Refill and re-pressurise as described in Section 12-Commissioning.

Operate the appliance and take note of any irregularities. Refer to Section 18-Fault Finding for rectification procedures.

If the combustion performance is to be checked:

Remove the cap from the sample point on the top of the appliance. Refer to Fig 37.

Connect an approved sampling meter.

With the appliance at maximum rate and stable in the DHW mode expect readings of:

24kW NG CO₂ 5.3—6.2% CO 0.002—0.010 %
LPG CO₂ 6.4—7.4% CO 0.004—0.010 %

28kW NG CO₂ 5.6—6.4% CO 0.006—0.010 %
LPG CO₂ 6.3—7.3% CO 0.003—0.010 %

NB For flues greater than 725mm without a restrictor the CO₂ may be up to 0.5% lower.

These figures cover all flue conditions.

Refit the cap after the test.

Disconnect the electrical supply at the mains and turn off the

Fig. 42. Inner case and facia fixing

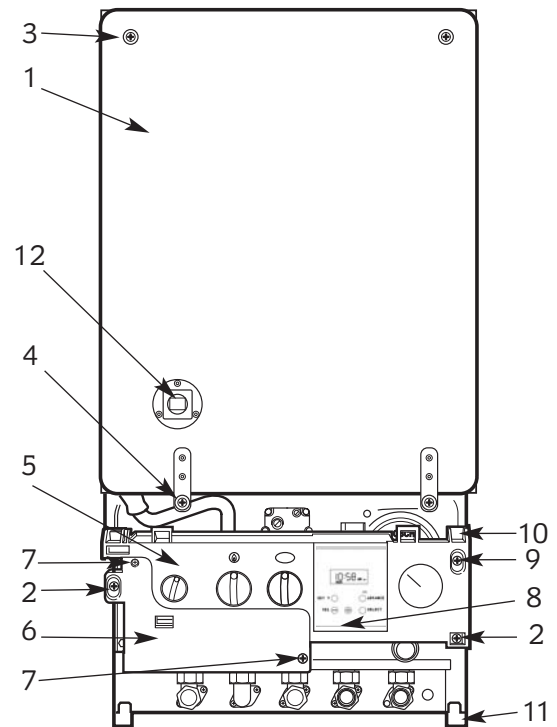

1. Inner casing cover
2. Cabinet fixing screws (4)
3. Inner casing cover fixing screws (2)
4. Inner casing cover fixing screws (2)
5. Facia control panel
6. Controls connector
7. Controls connector cover fixing screws (2)
8. Programmer (optional)
9. Facia control panel fixing screw
10. Top support lug (2)
11. Bottom support lug (2)
12. Sight glass

Fig. 43. Facia in service position

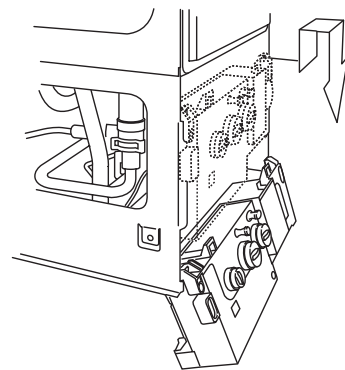

gas supply at the gas service cock on the appliance before starting any service procedures.

Always test for gas soundness after the service has been completed.

14.3 Component Access

To service the appliance it may be necessary to remove some or all of the following parts to gain access to components which may need to be checked or replaced.

Cabinet Pull off the clip-on facia cover. Unscrew the two screws and release the sides. Lift up and away from the top locating pegs.

Facia Panel Unscrew the single screw, lift off and lower onto the lower support lugs. Refer to Fig 42 & 43.

Fig. 44. Inner case components

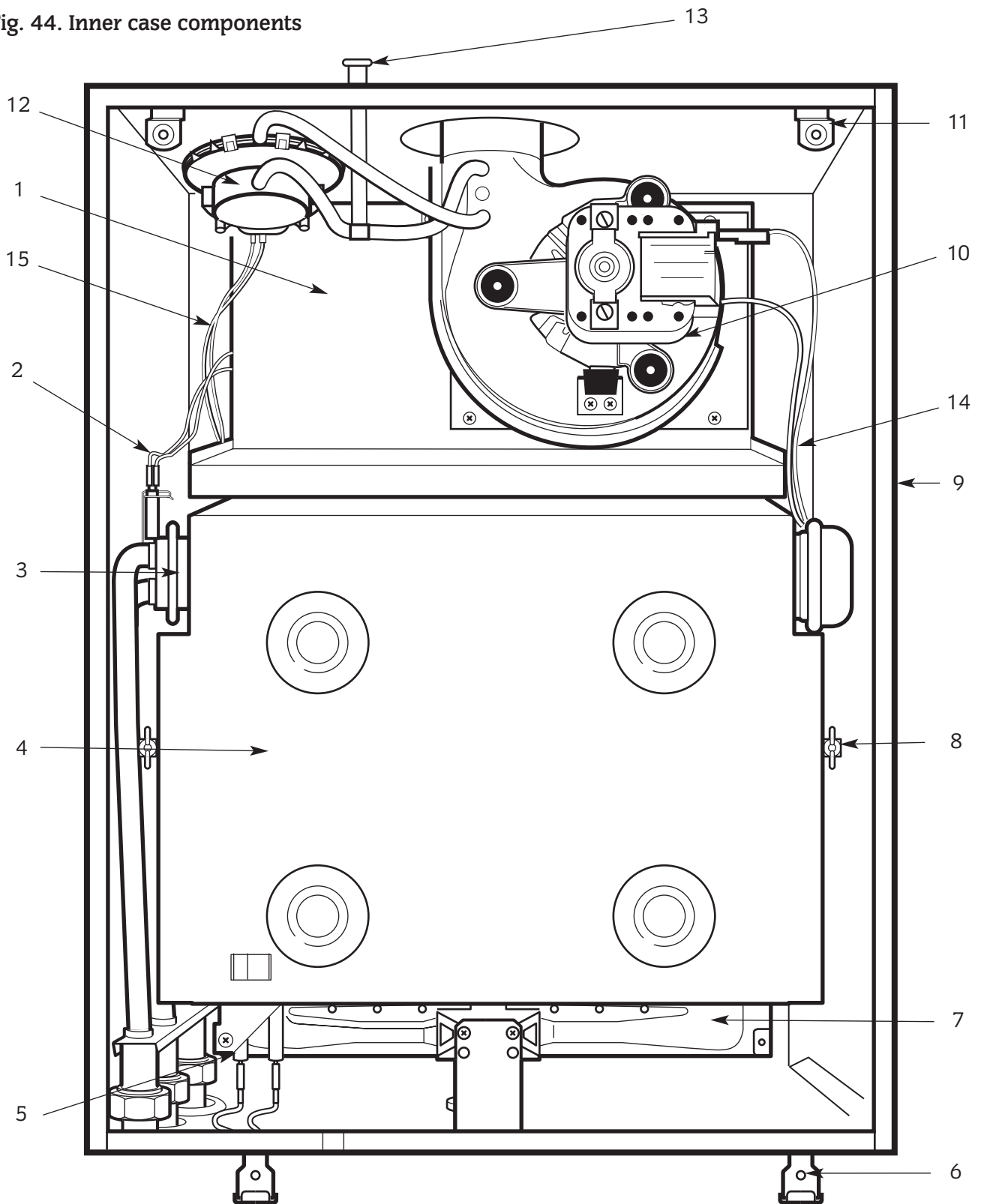

- | | |
|-------------------------------------|-----------------------------------|
| 1. Flue hood | 9. Inner case |
| 2. Primary sensor | 10. Fan assembly |
| 3. Heat exchanger | 11. Inner case cover fixing (top) |
| 4. Combustion chamber assembly | 12. Air pressure switch |
| 5. Spark electrode assembly | 13. Combustion sensing point |
| 6. Inner case cover fixing (bottom) | 14. Fan harness |
| 7. Burner assembly | 15. Main wiring harness |
| 8. Combustion chamber fixing screw | |

- Inner Case Cover** Unscrew the four screws and remove. Refer to Fig 42.
- Combustion Chamber** Unscrew the two screws at the top and the two wing nut extended screws at the sides, pull forward and remove. Refer to Fig 44.
- Fan** Carefully pull off the electrical connections and the tubes from the airflow-sensing device. Unscrew the four screws and remove the fan assembly. Refer to Fig 45.
- Flue Hood** Remove the fan. Unscrew the four screws and slide out the hood. Refer to Fig 47.
- Burner** Remove the combustion chamber. Carefully pull-off the connections to the spark electrodes. Pull off the connection to the flame sense electrode. Unscrew the support bracket. Release the union nut beneath the burner and carefully remove the burner. Refer to Fig 46.

14.4 Component Cleaning

Only use a non-metallic brush to clean components. Do not use a metal probe to clean the injectors.

Clean the fan taking care not to block air flow detector.

Clean the burner to ensure that the blades and injectors are clear.

Clean the electrodes, replace if there is any sign of deterioration.

Clean the heat exchanger. **Cover the gas inlet tube** and remove any deposits from the heat exchanger from the top and bottom. Carefully straighten any distorted fins on the heat exchanger.

Check the combustion chamber insulation and replace if there is any sign of damage or deterioration. Refer to Section 15.5.

Clean the controls in-situ using a non-metallic brush.

Carefully refit any components removed in the reverse order. Check that all screws are tight and the connections properly remade with the appropriate gaskets/O-rings.

Re-commission, as necessary, for correct operation to the users requirements. Refer to Section 12 Commissioning.

Fig. 45. Fan assembly

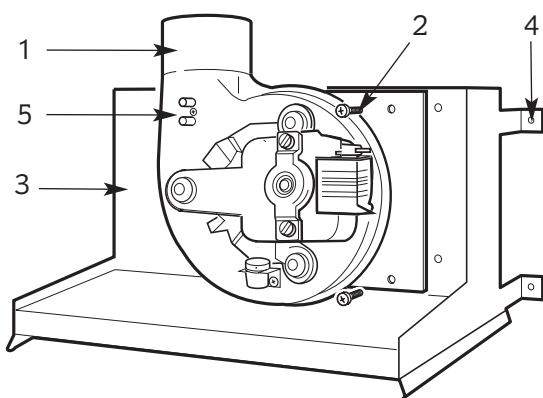

1. Fan assembly
2. Fan assembly fixing screws (4)
3. Flue hood
4. Flue hood fixing screws (4)
5. Air flow detector

Fig. 47. Flue hood

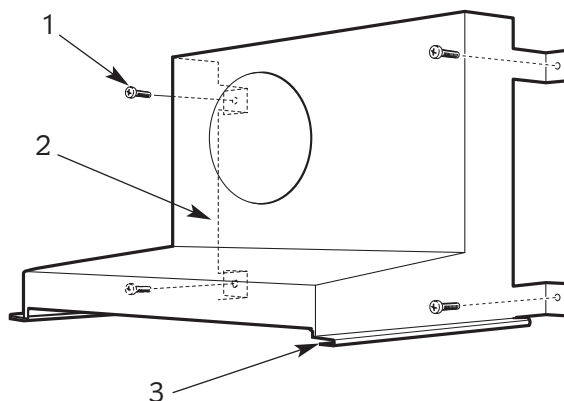

1. Flue hood fixing screws (4)
2. Flue hood
3. Flue hood/Heat exchanger guide

Fig. 46. Burner assembly

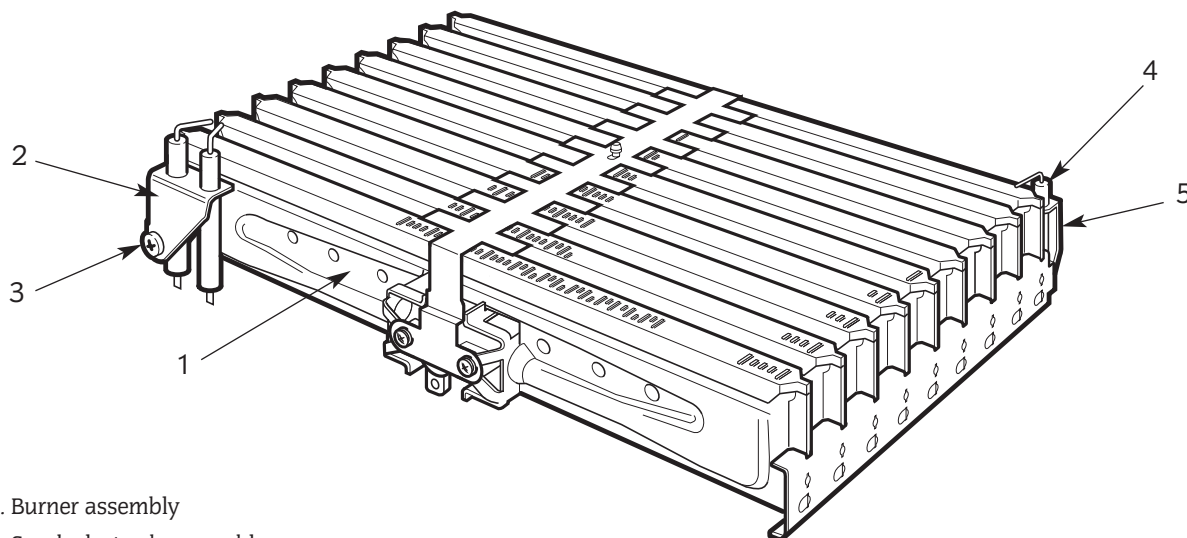

1. Burner assembly
2. Spark electrode assembly
3. Spark electrode assembly fixing screw
4. Flame sense electrode
5. Flame sense electrode fixing screw

15. Replacement Of Parts

IMPORTANT: Turn off the gas supply and electrically isolate the appliance before replacing any components.

After the replacement of any components always check for gas soundness where relevant and carry out functional checks as described in Section 12-Commissioning.

Any O-ring or gasket that appears damaged must be replaced. Complete gasket and O-ring packs are available for gas and water connections on the appliance.

Component Access

Refer to Section 14, Inspection and Servicing for access to components.

Draining the Appliance

Primary System: Turn off the heating flow and return valves at the appliance. Refer to Fig 17.

Open the drain tap a short tube is already connected to the drain point. Refer to Fig. 20. Close the drain tap when the flow from the appliance has stopped.

Fig. 48 . Lower casing - gas and water controls.

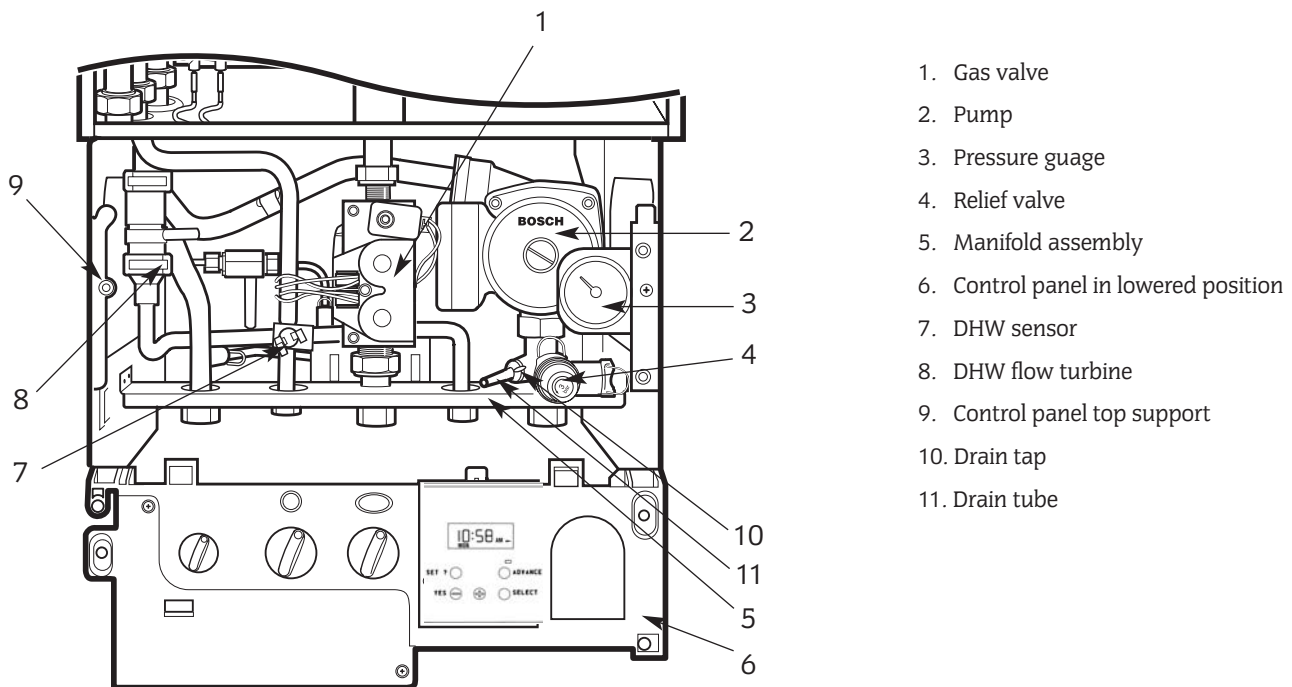

DHW Circuit: Turn off the mains cold water supply at the appliance. Refer to Fig 16. Open a hot tap below the level of the appliance to drain the domestic hot water from the appliance.

Important: A small quantity of water will remain in some components even after the appliance has been drained. Protect any electrical components when removing items from the water circuits.

Component Replacement

Refer to Fig 42 and 44 for an indication of the location of the various components.

Replace any components removed from the appliance in the reverse order using new gaskets/O-rings/sealant/heat transfer paste where necessary. Always check that any electrical connections are correctly made and that all screws are tight.

Remove casing and cover panels and lower the facia onto lower lugs, as necessary, to gain access to the components. Refer to Section 14, Inspection and Servicing.

15.1 Gas Valve

Unscrew the union connections above and below the gas valve and remove the assembly. Disconnect/unplug the electrical connections from the valve.

Use new gaskets when replacing the valve. Refer to Fig 48.

Set the Gas Valve:

Connect a pressure gauge to the burner and inlet pressure test points on the valve. Refer to Fig 39.

Switch on the gas and electricity supplies.

Check for gas tightness at the gas valve inlet.

Refer to Section 12.5 Commissioning for the method of checking/setting the pressures.

Check for gas soundness at the gas valve outlet.

Adjust the maximum and start pressure [minimum], as necessary, to obtain the required pressures. Switch off the appliance and disconnect the pressure gauge. and tighten the screw. Refer to Section 12.5 and Fig 39 for setting instructions.

Check for gas soundness at the test point.

Fig. 49. Spark electrode assembly

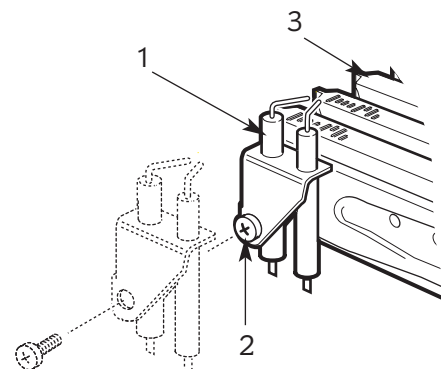

1. Spark electrode assembly

2. Fixing screw

3. Burner blade assembly (LH)

Fig. 50. Flame sense electrode

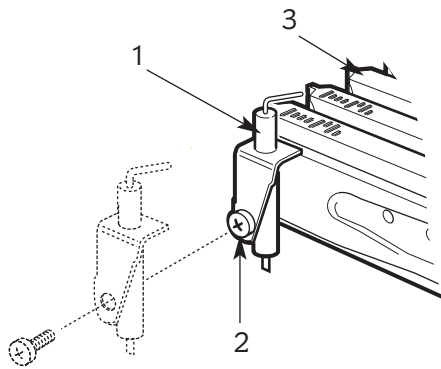

- 1. Flame sense electrode
- 2. Fixing screw
- 3. Burner blade assembly (RH)

15.2 Spark Electrode

Remove the inner casing cover and the combustion chamber. Carefully pull off the lead from the electrode. Unscrew the screw and remove the assembly. Refer to Fig 49. Ensure that the electrode is at the correct height above the burner blade. $6.5\text{mm} \pm 1\text{mm}$.

15.3 Flame Sense Electrode

Remove the inner casing cover and the combustion chamber. Remove burner as in 15.4. Carefully pull off the leads from the electrode assembly. Unscrew the screw and remove the assembly. Refer to Fig 50. Ensure that the sense electrode is at the correct height above burner blade. $6.5\text{mm} \pm 1\text{mm}$.

15.4 Burner

Remove the inner casing cover and the combustion chamber. Remove the spark electrode connections. Unscrew the two burner bracket fixing screws. Release the union connection beneath the burner and remove the burner from the appliance. Refer to Fig. 46. and 51. Do not omit the gasket when fitting the new burner.

Fig. 51. Burner

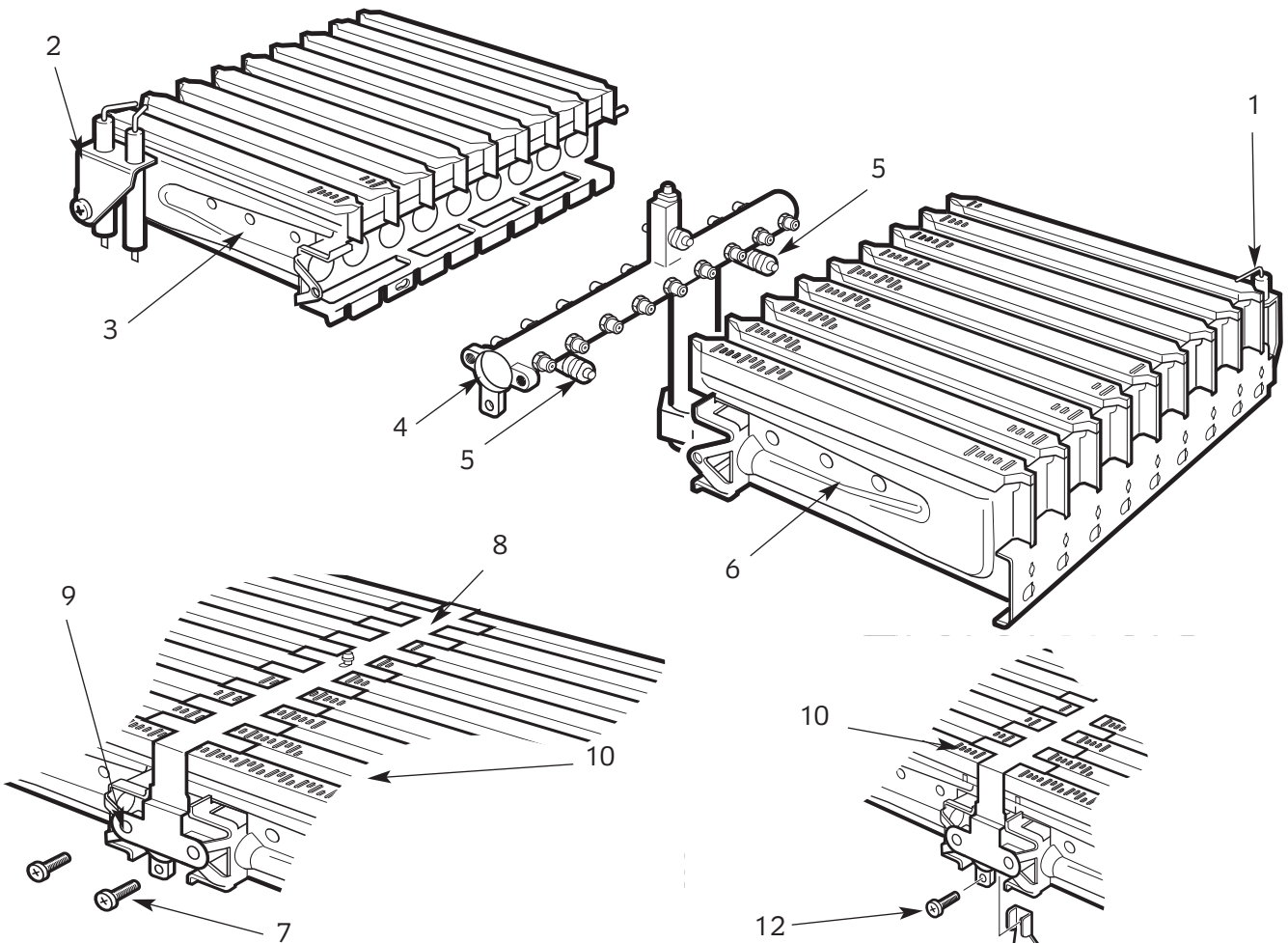

- 1. Flame sense electrode
- 2. Spark electrode assembly
- 3. Burner blade assembly (LH)
- 4. Burner manifold
- 5. Burner blade assembly location points
- 6. Burner blade assembly (RH)
- 7. Cross-lighting strip fixing screws (2)
- 8. Cross-lighting strip
- 9. Cross-lighting strip fixing holes (2)
- 10. Burner assembly
- 11. Burner support bracket
- 12. Burner fixing screw
- 13. Bracket fixing screws (2)

15.5 Combustion Chamber Insulation, Front & Sides

Remove inner casing door and combustion chamber. Remove damaged insulation, replacement is the reverse of removal. See Fig 52.

Combustion Chamber Insulation, Rear

Remove heat exchanger as described in 15.21.

Remove side panels first.

Pull insulation forward and up to remove.

Replacement is the reverse of removal. Refer to Fig 52.

Fig. 52. Combustion Chamber Insulation Front and Sides.

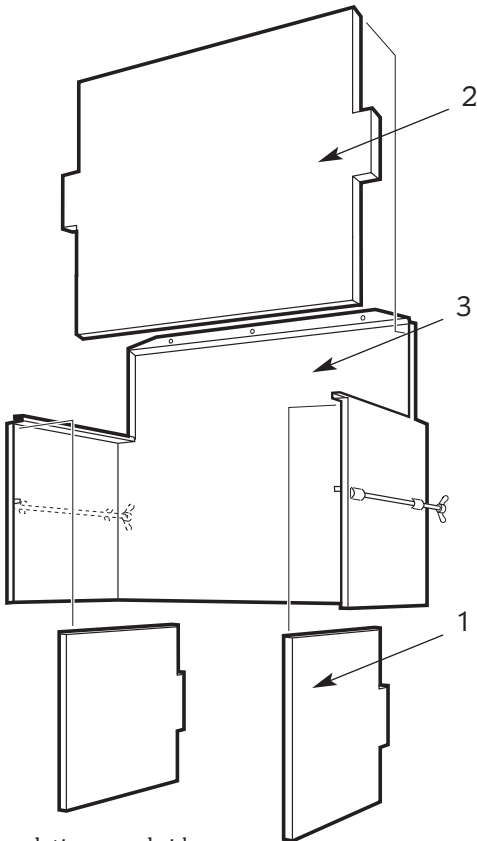

- 1. Insulation panel-side
- 2. Insulation panel-front
- 3. Combustion chamber assembly

15.6 Pressure Gauge

Remove the clip-on facia cover, cabinet and lower the facia panel onto the lower support lugs. Refer to Fig 43. Check that the appliance has been fully drained. Withdraw the clip and remove the pressure-sensing head. Refer to Fig 53.

Unclip the gauge head from its mounting bracket and remove. Refer to Fig 53.

Do not omit the washer from the pressure capillary when fitting the replacement gauge.

Fig. 53. Pressure Gauge head

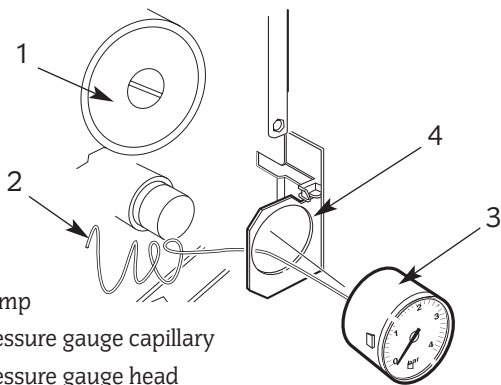

- 1. Pump
- 2. Pressure gauge capillary
- 3. Pressure gauge head
- 4. Mounting bracket

Fig. 54. Relief valve boiler drain connection

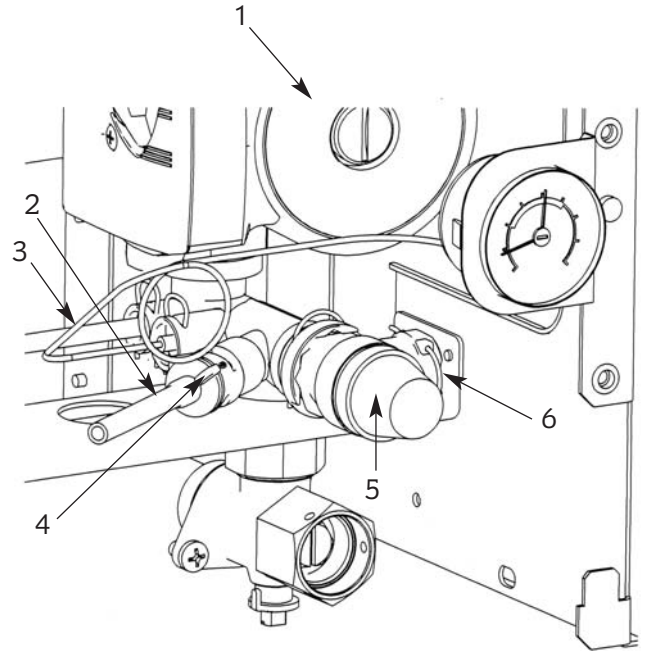

- 1. Pump
- 2. Boiler drain
- 3. Pressure gauge capillary
- 4. Boiler Drain ON/OFF
- 5. Relief valve
- 6. Relief valve drain connection (push fit)

15.7 Relief Valve

Remove the clip-on facia cover, cabinet and lower the facia onto the lower support lugs.

Check that the appliance has been fully drained.

Unclip and pull-out the valve body. Refer to Fig 54

Fig. 55. Water flow turbine.

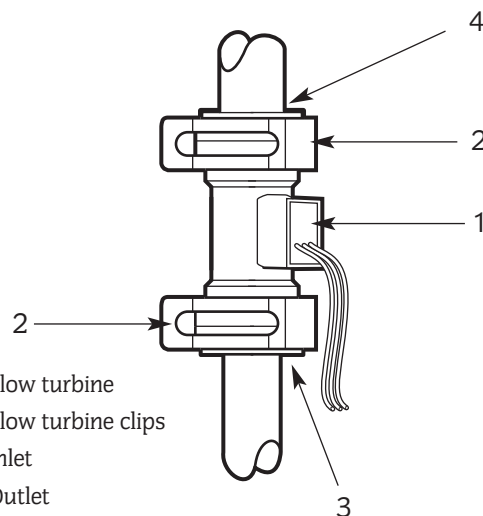

- 1. Flow turbine
- 2. Flow turbine clips
- 3. Inlet
- 4. Outlet

15.8 Flow Turbine

Drain the DHW circuit as described at the start of Section 15 preceding.

Remove the clip on facia cover, cabinet and lower the facia panel onto the lower support lugs. Separate the in-line connector. Remove the two fixing clips and withdraw the turbine. Refer to Fig 48 and 55.

Do not omit the gaskets when fitting the replacement turbine.

15.9 Inlet Water Filter

Remove the flow turbine as described in 15.8 preceding. Taking care, remove flow restrictor assembly from the flow turbine inlet. Refer to Fig 55 Carefully clean wire mesh by back flushing with water or replace assembly if necessary. Refer to Fig 56.

Fig. 56. Inlet water filter and flow restrictor

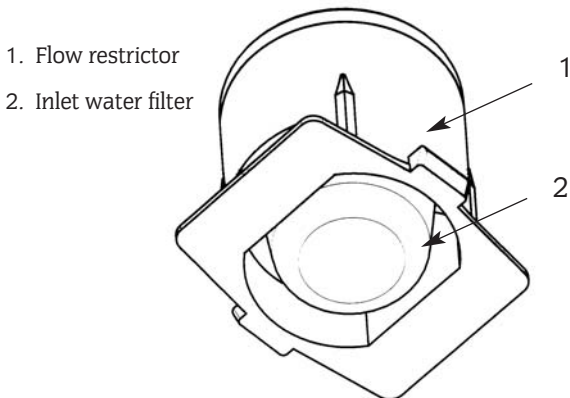

- 1. Flow restrictor
- 2. Inlet water filter

15.10 Control Board

Remove the clip-on fascia cover, cabinet and the connections cover. Carefully disconnect all the electrical connections. Refer to Fig 35 and 43.

Remove the fascia panel and unscrew the four screws and remove the cover from the rear of the fascia. Refer to Fig 57. Lift out the control board. Refer to Fig 57

Pull out and transfer the transformer to the new board. Re-commission the appliance to check and set the burner pressures. Refer to Section 12, Commissioning.

15.11 Transformer

Unscrew the four screws and remove the cover from the rear of the fascia as described in 15.10 preceding. Refer to Fig 57.

Pull out and transfer the transformer to the new board. Refer to Fig 57.

Fig. 57. Control board

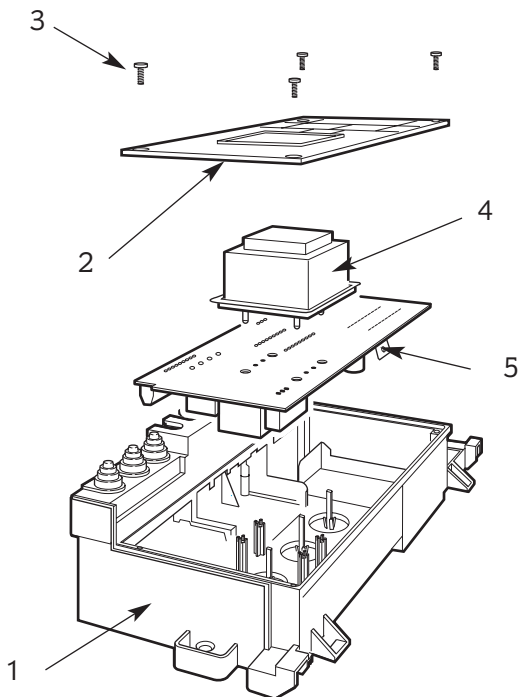

- 1. Control panel
- 2. Rear cover
- 3. Rear cover fixing screws (4)
- 4. Transformer
- 5. Control board

15.12 Clock/Programmer

Remove the fascia by gently pulling it away from the boiler to release the clips.

Remove the clock/programmer assembly by releasing the clip at the top of the clock/programmer and ease away from the control panel being careful not to pull on the connector lead. Unplug the connector at the control board. Refer to Fig 58. Comprehensive instructions are sent with the new control.

Fig. 58. Programmer connection

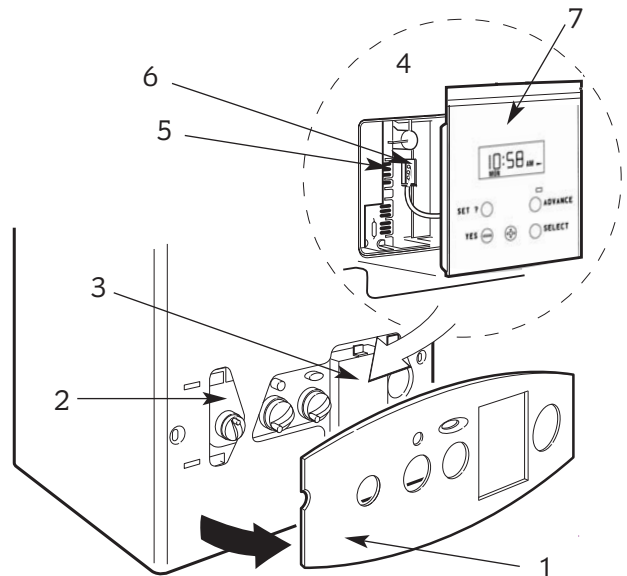

- 1. Fascia (gently pull forward to un-clip and remove)
- 2. Control panel (boiler outer casing in place)
- 3. Programmer cover (un-clip to remove. See Fig. 34)
- 4. Programmer location in detail
- 5. Programmer connections (See Fig. 34)
- 6. Programmer connector plug
- 7. Programmer

15.13 Fan

Remove the inner casing cover. Remove the fan as described in Section 14.3, Inspection and Servicing.

Ensure that all the connections are correctly made to the new fan.

15.14 Air Flow Detector

Remove the fan as described in 15.13 preceding. Unscrew and withdraw, through the fan outlet, the airflow detector. Refer to Fig 45.

15.15 Primary [ch] Sensor

Remove the clip-on facia cover, cabinet and inner casing cover. Carefully pull-off the connections. Release the clip and lift out the sensor. Refer to Fig 59 and 62.

Do not omit the heat transfer paste when fitting the replacement sensor.

15.16 Overheat Thermostat

Remove the clip-on facia cover, cabinet and the inner casing cover.

For the position of the overheat thermostat refer to Fig 62.

Carefully pull-off the connections. Unscrew the two screws and remove the thermostat and fixing bracket. Refer to Fig 60. Apply a small quantity of heat transfer paste to the face of the replacement thermostat.

Carefully position the thermostat so that the connections are away from the flue hood.

15.17 DHW Sensor

Remove the clip-on facia cover, cabinet and lower the facia onto the lower support lugs.

Carefully pull off the connections. Unscrew the clip and remove the sensor.

Apply a small quantity of heat transfer paste to the face of the replacement sensor. Refer to Fig 61.

15.18 Pump

Check that the primary circuit has been fully drained.

Use a 4mm Allen key to release the four pump head fixing screws and remove the pump head. Refer to Fig 48.

Disconnect and transfer the electrical connections to the new pump head. Take care not to scratch the mating surfaces.

15.19 Expansion Vessel

It will be necessary to remove the appliance from the wall to replace the expansion vessel. Refer to Fig 37.

Alternatively the specified replacement can be fitted into the heating system return as close to the appliance as possible.

Re-fill and pressurise the system as described in Section 13 Commissioning.

15.20 Auto Air Vent

Drain the primary circuit.

Unscrew and remove the auto air vent. Do not omit the sealing washer when fitting the replacement air vent. Remove the cap. Refer to Fig 37.

15.21 Primary Heat Exchanger

Check that the appliance has been fully drained.

Remove the temperature sensors as described in 15.15, 16 and 17 preceding.

Remove the combustion chamber, fan and flue hood as described in Section 14.3, Inspection and Servicing and burner as described in 15.4. NOTE: The heat exchanger is unsupported when both the combustion chamber and flue hood are removed.

Undo the four union connections and remove the heat exchanger. Do not omit the sealing washers when fitting the replacement heat exchanger. Refer to Fig 62.

Fig. 59. Primary (CH) sensor.

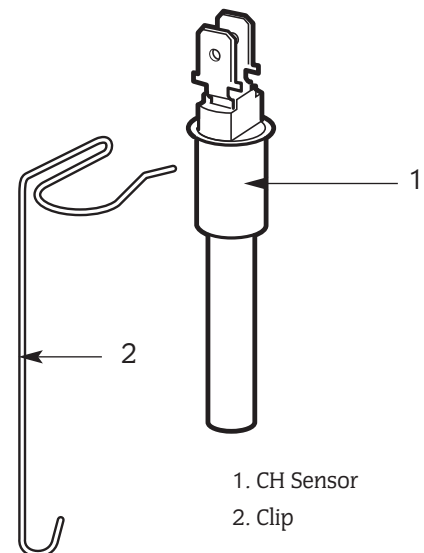
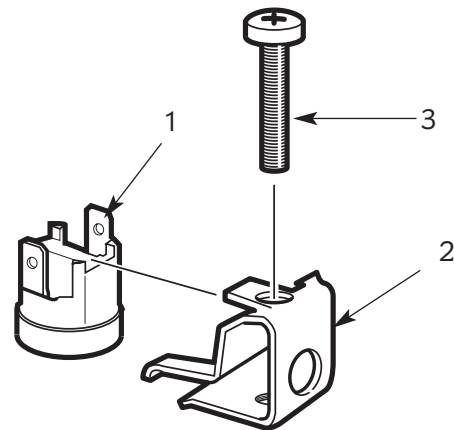
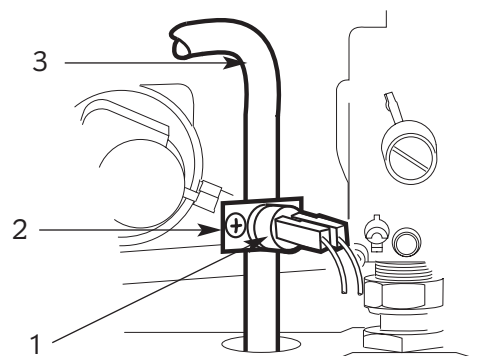

Fig. 60. Overheat thermostat



- 1. Overheat thermostat
- 2. Fixing bracket
- 3. Overheat thermostat fixing screw

Fig. 61. DHW sensor



- 1. DHW sensor
- 2. DHW sensor fixing bracket and screw
- 3. DHW outlet pipe

Fig. 62. Primary heat exchanger

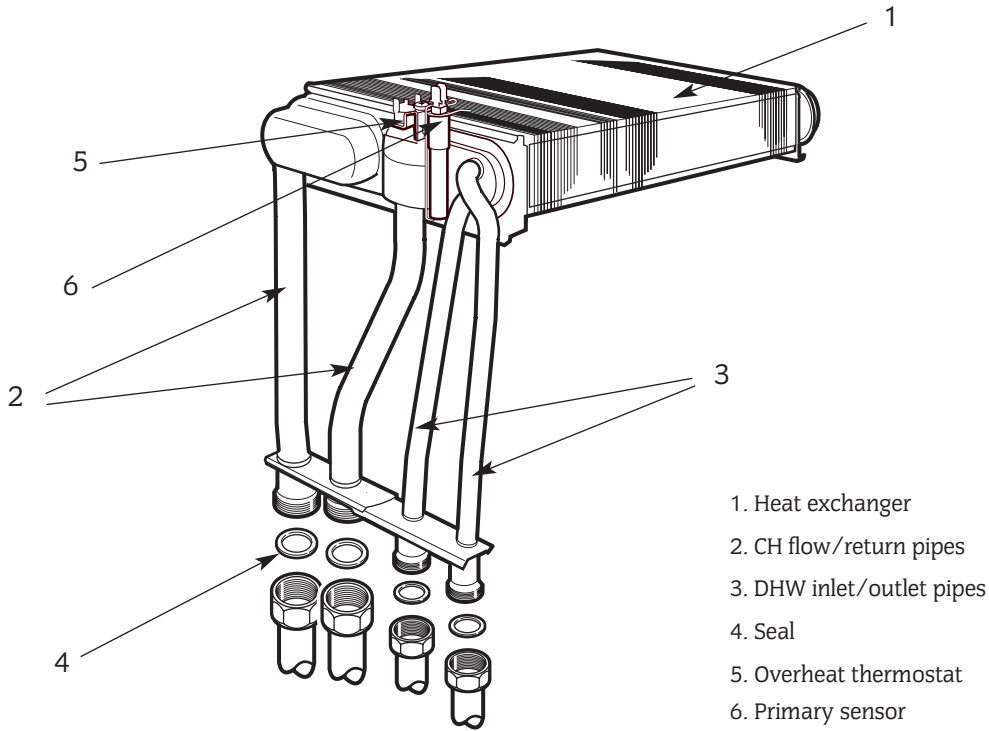

- 1. Heat exchanger
- 2. CH flow/return pipes
- 3. DHW inlet/outlet pipes
- 4. Seal
- 5. Overheat thermostat
- 6. Primary sensor

15.22 Air pressure Switch

The air pressure switch is held in position by a fixing bracket. In order to remove the switch:

Gently move outwards the securing clips holding the switch to the bracket.

Remove the air pressure tubes and wires from the switch.

Push the replacement switch, with the tube connectors pointing forwards, into the bracket and then replace the wires and pressure tubes.

If the fixing bracket needs replacing, remove the switch as described above then remove the two screws holding the bracket to the top of the appliance. Refer to Fig 63 and 64.

15.23 Sight Glass

Remove and replace the inner casing cover complete.

Refer to Section 14.3, Inspection and Servicing. Refer to Fig 42.

Fig. 63. Air flow pressure switch location

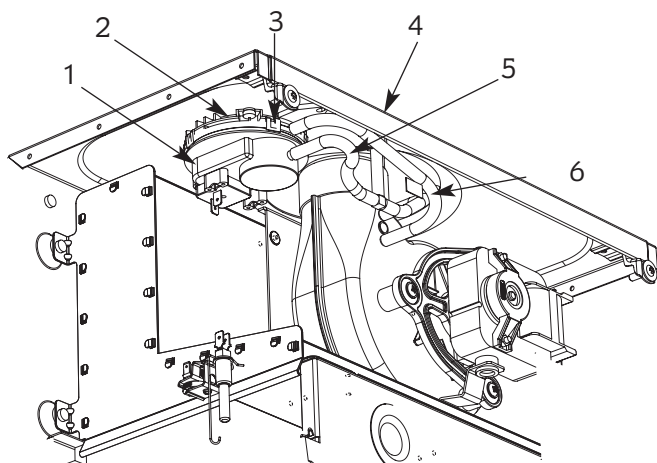

- 1. Air pressure switch
- 2. Fixing bracket
- 3. Air pressure switch fixing clip
- 4. Combustion sensing point location
- 5. Negative pressure tube (-)
- 6. Positive pressure tube (+)

Fig. 64. Air flow pressure switch

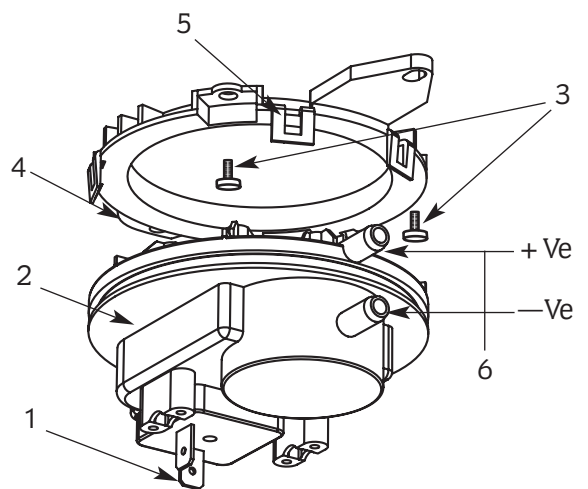

- 1. Electrical connections
- 2. Air pressure switch
- 3. Screws
- 4. Air pressure switch fixing clip
- 5. Securing clip
- 6. Tube connectors

16. Short Parts List

Key No.	G.C. No.	Part	Qty	WHS Part No.
1	E88-141	Burner 24Si II NG RSF	1	8 716 101 900 0
2	E88-142	Burner 24Si II LPG RSF	1	8 716 102 396 0
3	E88-143	Burner 28Si II NG RSF	1	8 716 105 008 0
4	E88-144	Burner 28Si II LPG RSF	1	8 716 105 009 0
5	E88:450	Gas Valve NG Dungs BN771SL040 - 239675	1	8 716 102 673 0
6	E88:451	Gas Valve LPG Dungs BN771SL040 - 239676	1	8 716 102 868 0
7	E88-146	Air Pressure Switch	1	8 716 104 896 0
8	E88-169	Electrode Set (Flame and Ignition)	1	8 716 101 901 0
9	E88-170	Overheat Stat	1	8 717 206 200 0
10	375-696	NTC/Thermistor DHW	1	8 716 142 302 0
11	E88-171	NTC/Thermistor CH	1	8 714 500 029 0
12	378-809	Air Vent Manual 1/4 BSP	1	8 716 140 516 0
13	299-363	Air Flow Sensor	1	8 716 141 000 0
14	E88-172	Heat Exchanger 24Si II	1	8 715 406 670 0
15	E88-173	Heat Exchanger 28Si II	1	8 715 406 814 0
16	E88-174	Insulation Pack 24Si II	1	8 716 101 877 0
17	E88-175	Insulation Pack 28Si II	1	8 761 105 010 0
18	E88-176	Pressure Gauge	1	8 716 142 398 0
19	E27-580	Pressure Relief Valve	1	8 716 156 764 0
20	E88-177	Pump	1	8 716 143 116 0
21	E27-587	Expansion Vessel	1	8 715 407 154 0
22	H02-152	Control Board	1	8 748 300 488 0
23	E88-179	Fan Assembly - 24Si II	1	8 716 104 814 0
24	E88-180	Fan Assembly - 28Si II	1	8 716 104 815 0
25	E88-181	Flow Sensor	1	8 716 146 164 0
26	E88-182	Seal-Door Extrusion	1	8 716 104 609 0
27	E88-183	Transformer	1	8 747 210 294 0
28	E88-184	Flow Regulator 24Si II	1	8 716 141 255 0
29	E88-185	Flow Regulator 28Si II	1	8 716 141 253 0
30	H02-155	Code Plug 24Si II RSF	1	8 714 421 166 0
31	H02-157	Code Plug 28Si II RSF	1	8 714 421 167 0

Accessories and Kits

A001	Charging Link Assembly	1	7 716 192 281
A002	Installer Pre-Filling Kit	1	7 716 192 282
A004	Gas Conversion Kit NG to LPG 24Si II	1	7 716 192 288
A005	Gas Conversion Kit NG to LPG 28Si II	1	7 716 192 289
A006	Simplefit Telescopic Flue Kit - F105H500	1	7 716 191 068
A007	Vertical Flue Kit	1	7 716 191 079
A008	90° Flue Elbow - F106E90	1	7 716 191 013
A009	45° Flue Elbow (Pair) - F 106E45	2	7 716 191 014
A010	Vertical Flue Adaptor Kit	1	7 716 191 016
A011	Security Kit	1	7 716 192 246
A012	Mechanical Programmer	1	7 716 192 027
A013	Digital Programmer	1	7 716 192 028

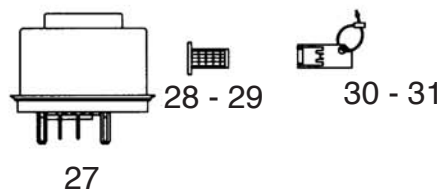
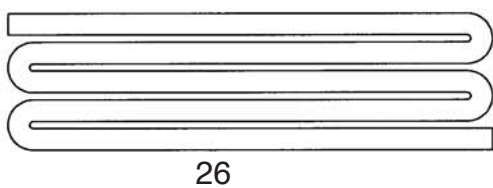
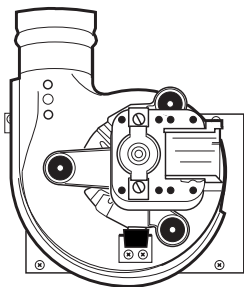
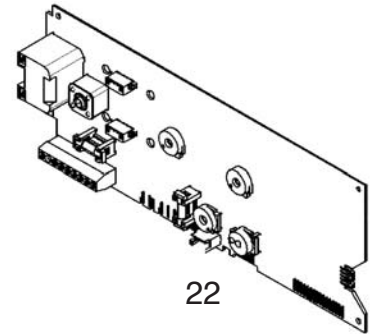
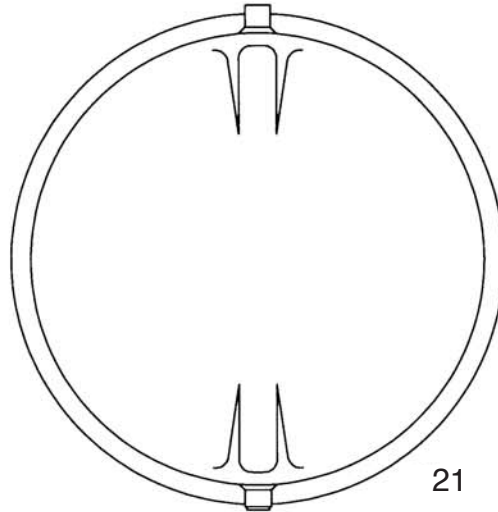
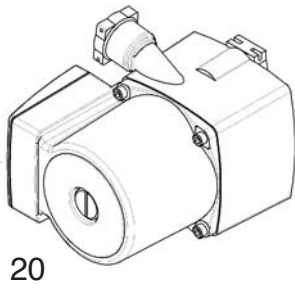
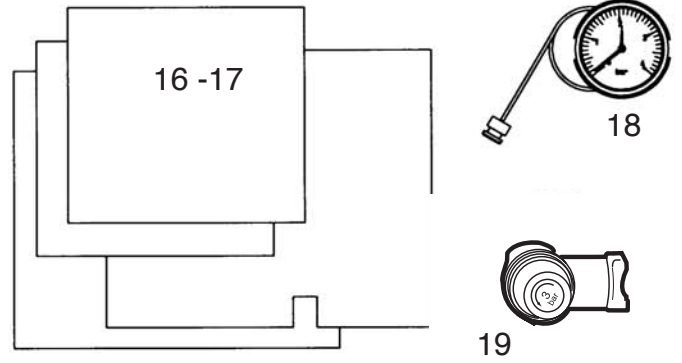
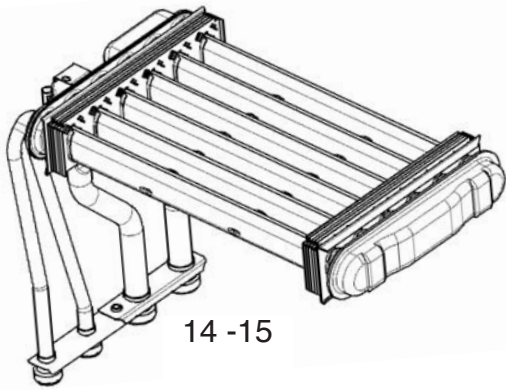
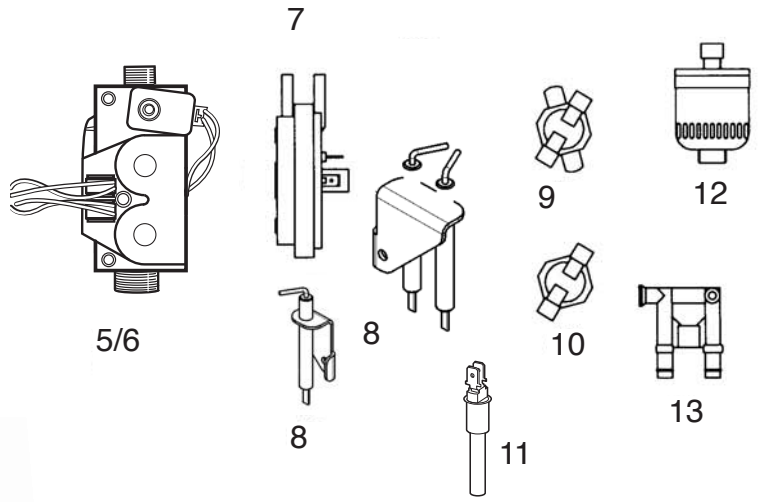
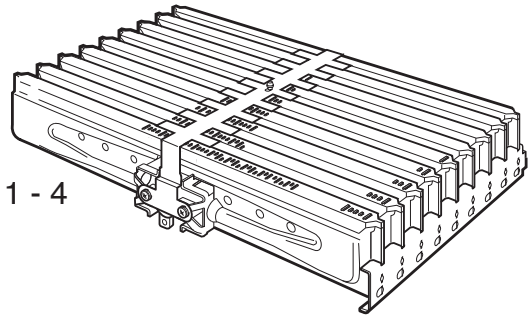

17. Operational Flow Diagrams

CENTRAL HEATING FUNCTION

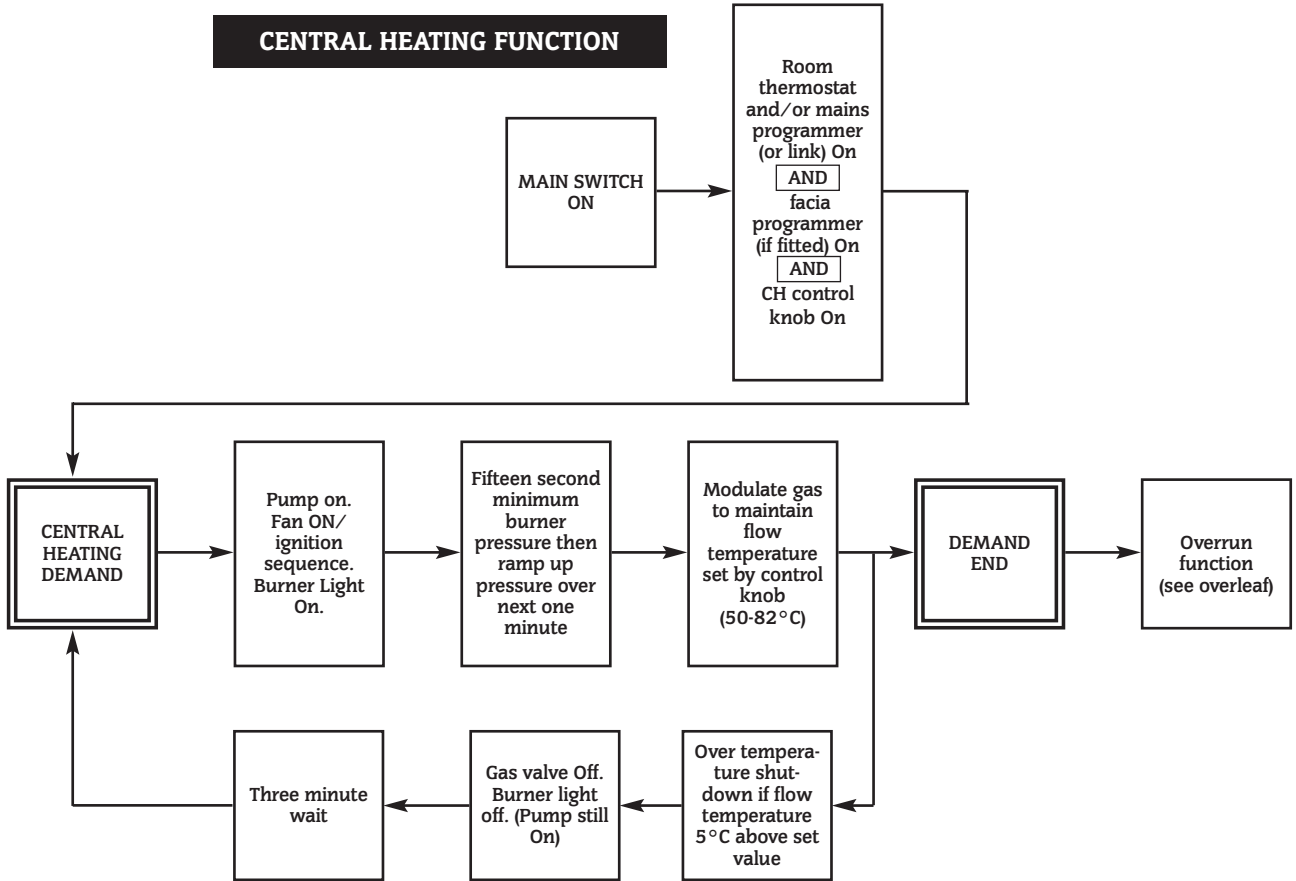

DOMESTIC HOT WATER FUNCTION

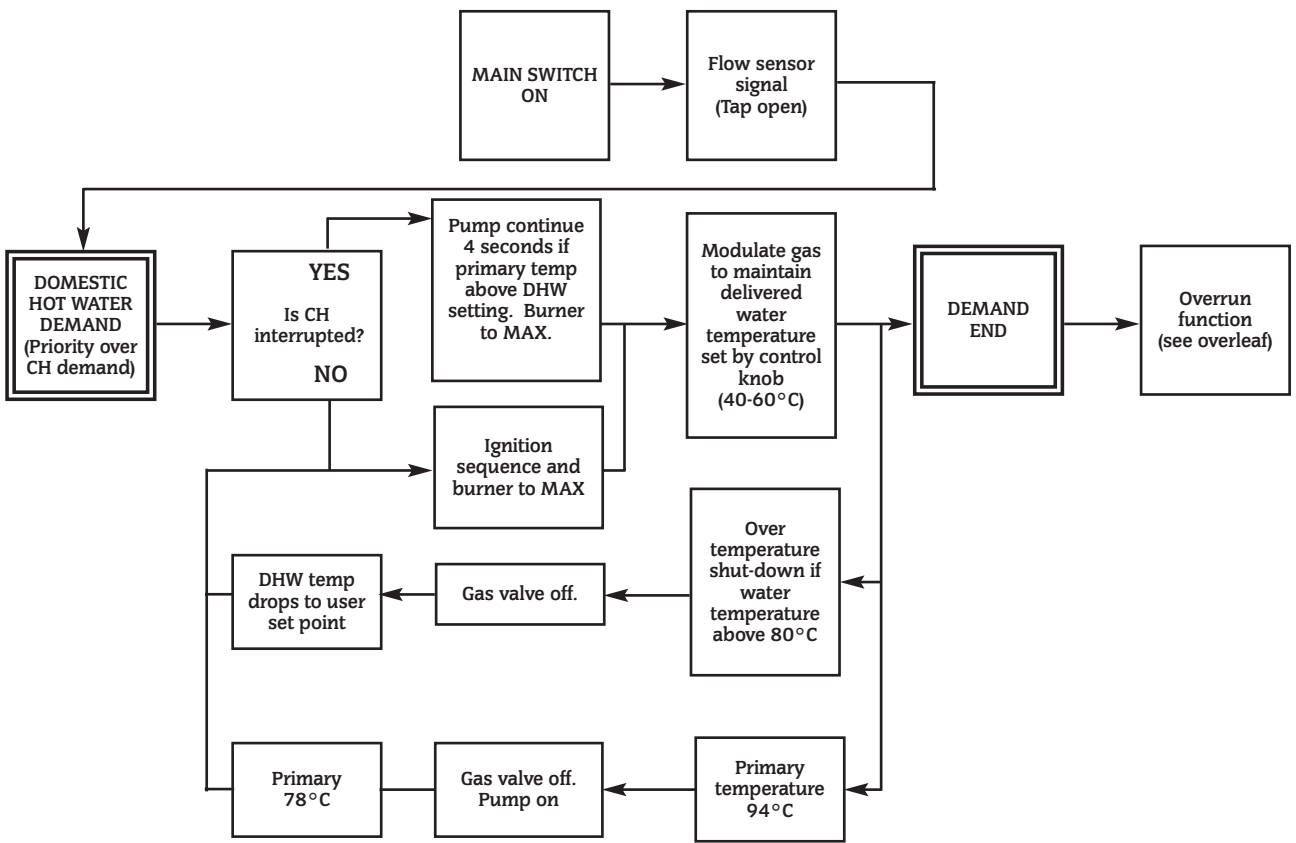

OVERRUN FUNCTION

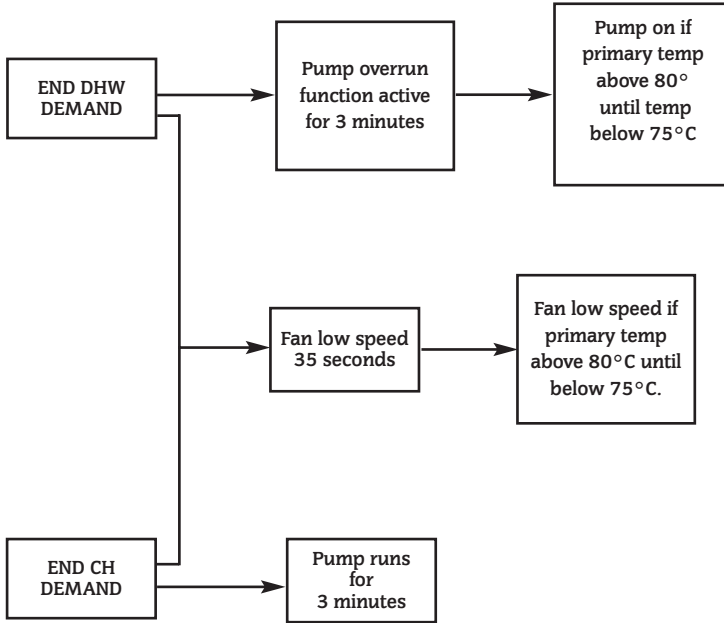

AUTOFROSTAT FUNCTION

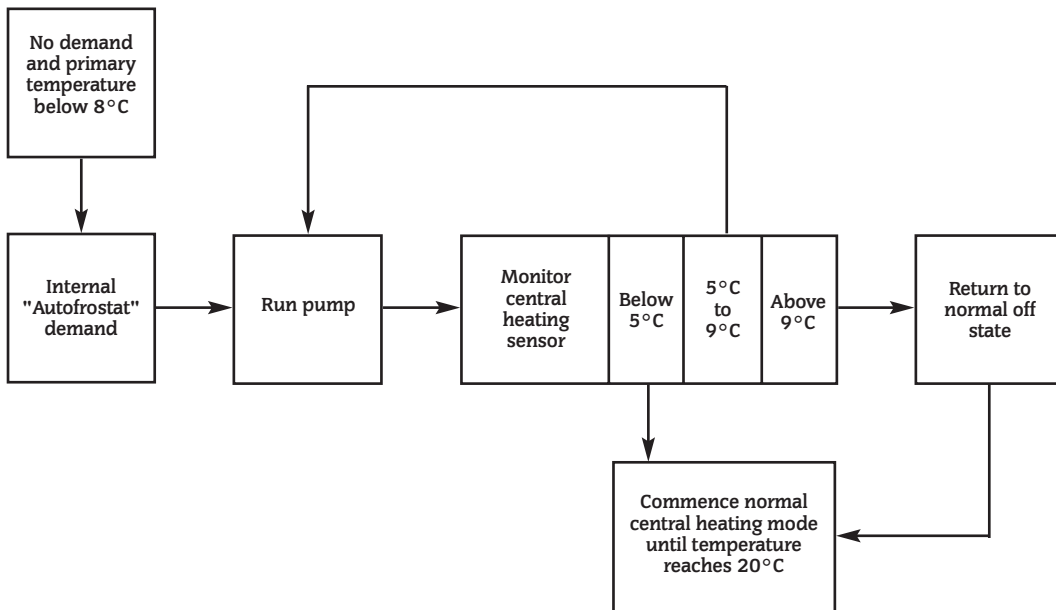

18. Fault Finding

Note: This fault-finding information is for guidance only. Worcester, Bosch Group cannot be held responsible for costs incurred by persons not deemed to be competent.

By flashing at various rates, the oval shaped facia light will indicate specific fault conditions. If this is used with other observations during a fault, then every normal fault can be identified.

To use the fault finding system, use the table below to select the failure condition during your fault. The most common causes are listed, then refer to the test in the following section. This fault finding system assumes that the appliance has been operating normally until the time of failure (ie not a first installation fault).

PRELIMINARY CHECKS

Preliminary electrical system checks are the first electrical checks to be carried out during a fault-finding procedure. On completion of the Service/Fault-Finding task which has required the breaking and remaking of electrical connections, check (a) EARTH CONTINUITY, (b) SHORT CIRCUIT CHECK, (c) POLARITY and (d) RESISTANCE TO EARTH.

FAULT LIST

OBSERVED FAULT	COMMON CAUSES	SEE TEST
No lights and no functions (with demand)	No mains Voltage supply. Fuse F1 or F2 blown. Transformer or connector failed. Board fault.	A
No CH function (DHW OK)	No link at ST2 Ls to Lr, or failed external control input to Lr. Failed programmer. Board fault.	B
No DHW function (CH OK)	Flow sensor failure. DHW sensor (LED 4 flash/second). Board fault.	C
Flash once per second <i>Ignition lockout</i> <i>Overheat lockout</i> <i>Internal error</i> <i>(reset lockout by gently pressing reset button for 5 seconds)</i>	No gas or low gas pressure. Weak spark or spark not across electrodes. Gas valve leaking or failed. Low water pressure or boiler dry. Pump fail. Primary sensor position. Flame sensor fail or connector. Overheat stat tripped or disconnected or faulty. Blocked burner. Blocked heat exchanger. Faulty harness. Board fault.	D
Flash 4 times per second	Code plug missing or failed. CH or DHW Sensor fault or out of position. Air pressure switch fault or condense in tubes. Fan fail or stiff. Blocked flue. Faulty harness. Board fault.	E
Flash 8 times per second <i>GV mode switch</i>	Gas Valve mode switch on min or max.	F
Burner on with no demand	Autofroststat. Board fault.	G
Water temperature too hot	Sensor off pipe.	H
Water temperature too cool	Low gas pressure. Pot P1 not turned up. Stiff/sticking gas valve. Stiff/sticking flow sensor. Board fault.	I

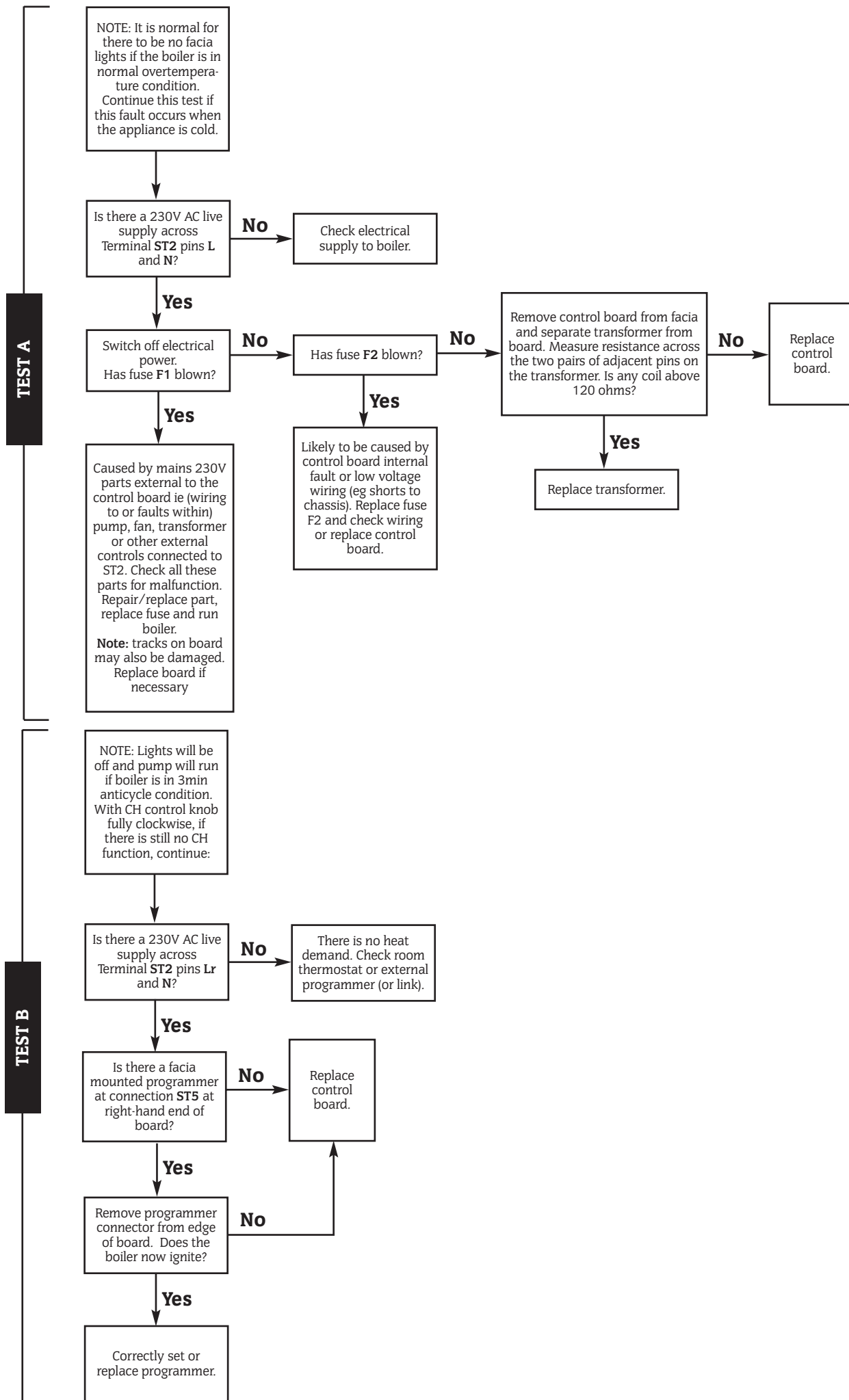

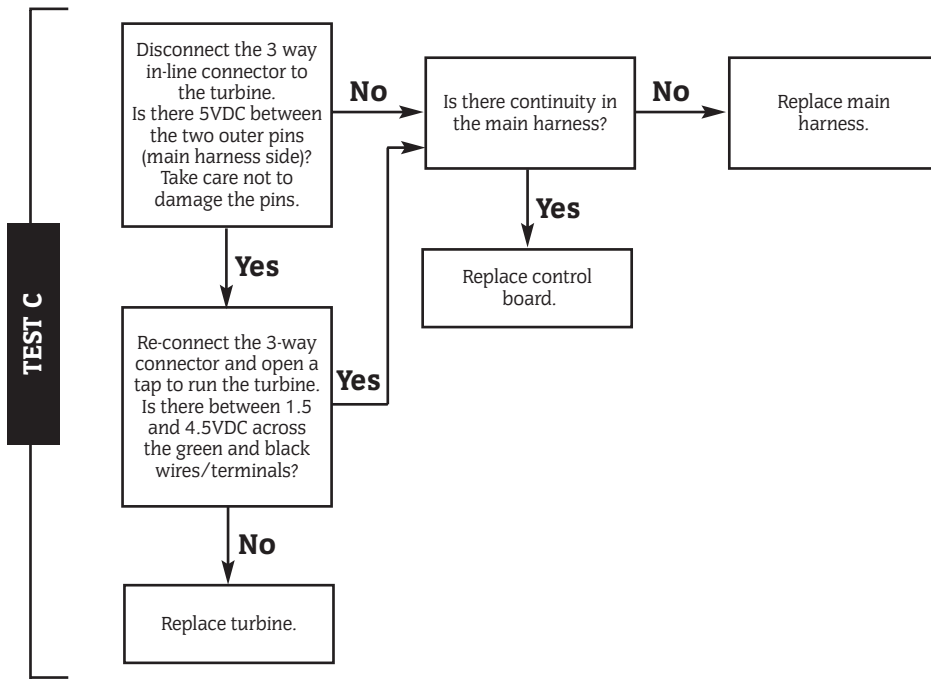

TEST D

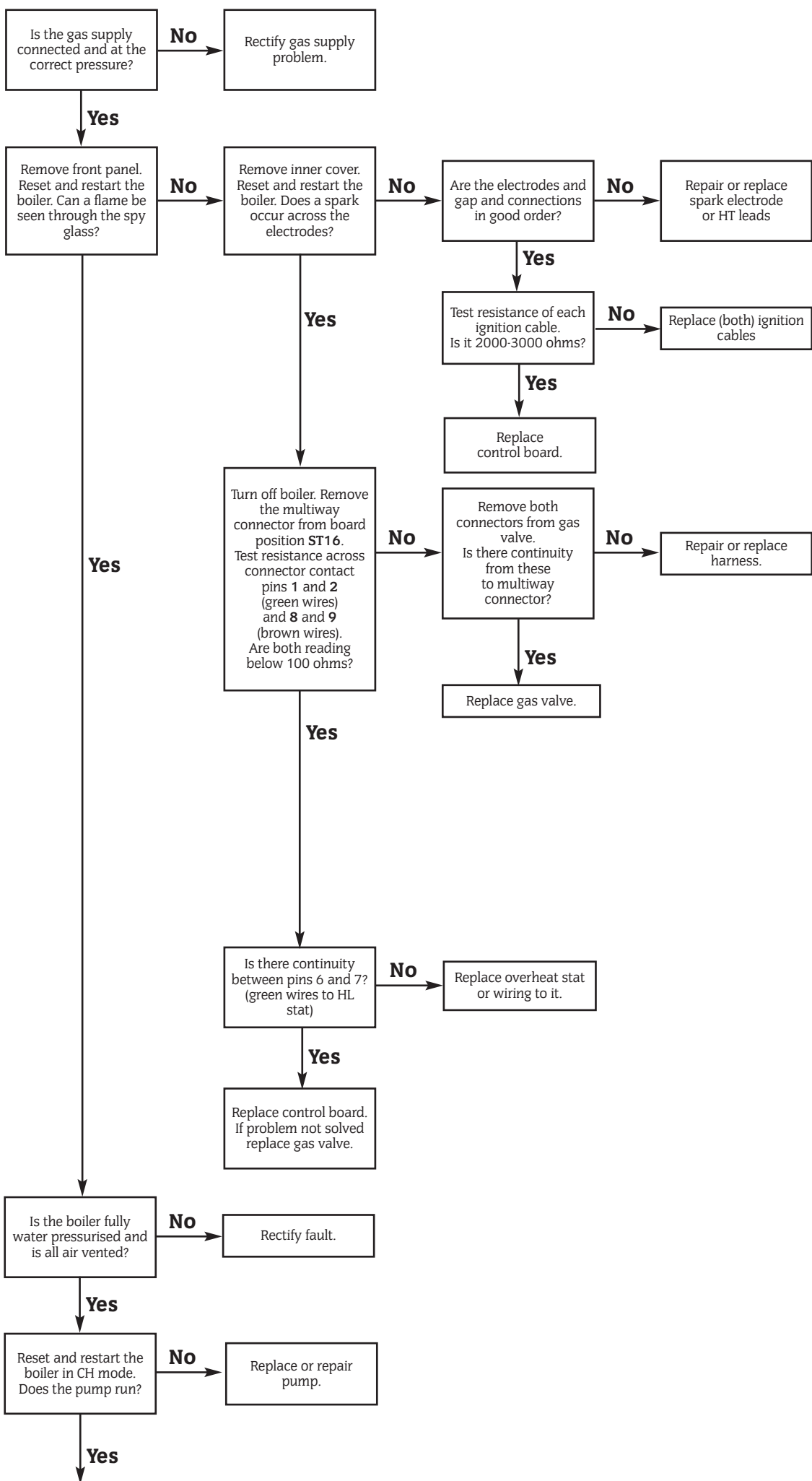

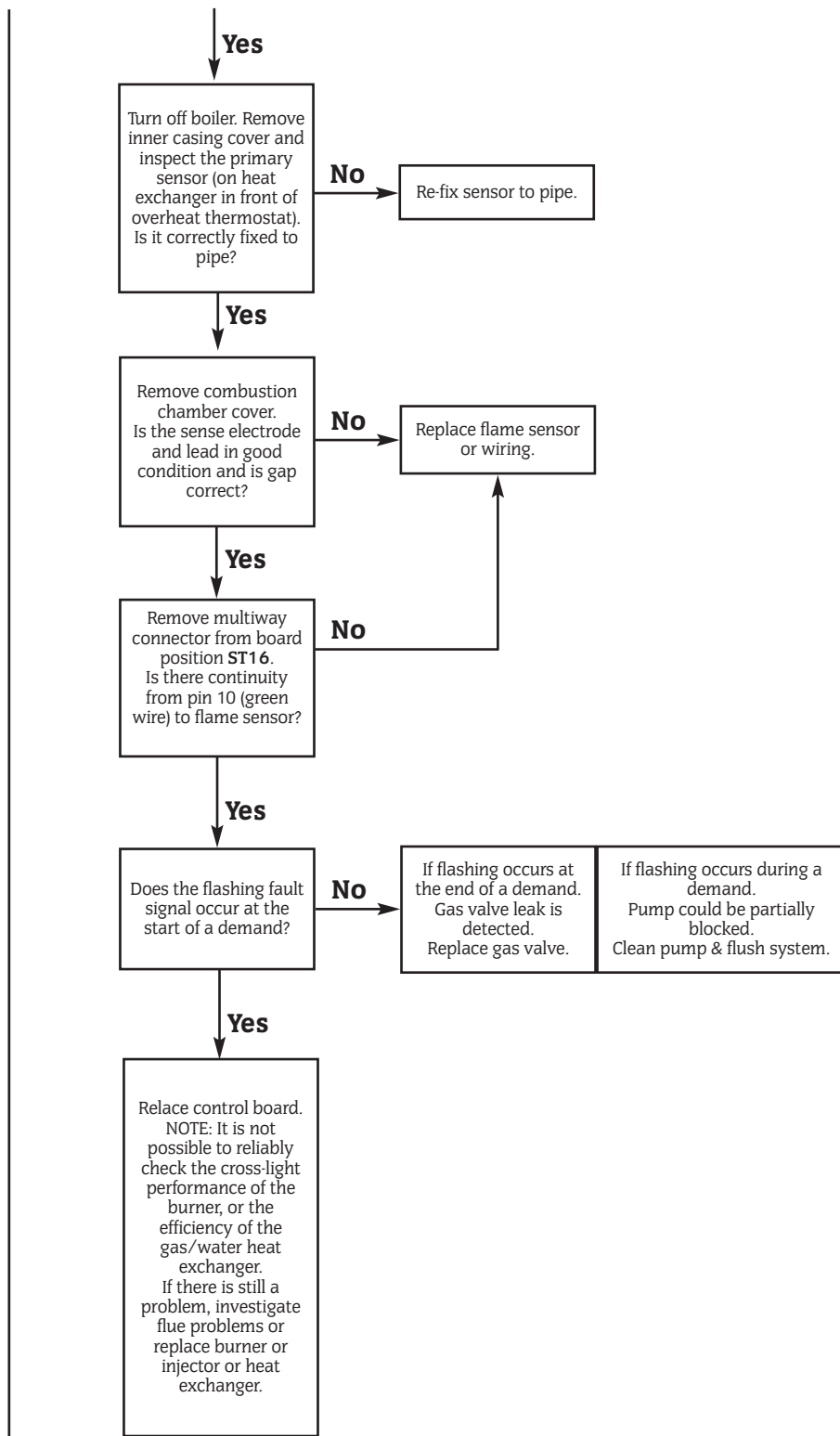

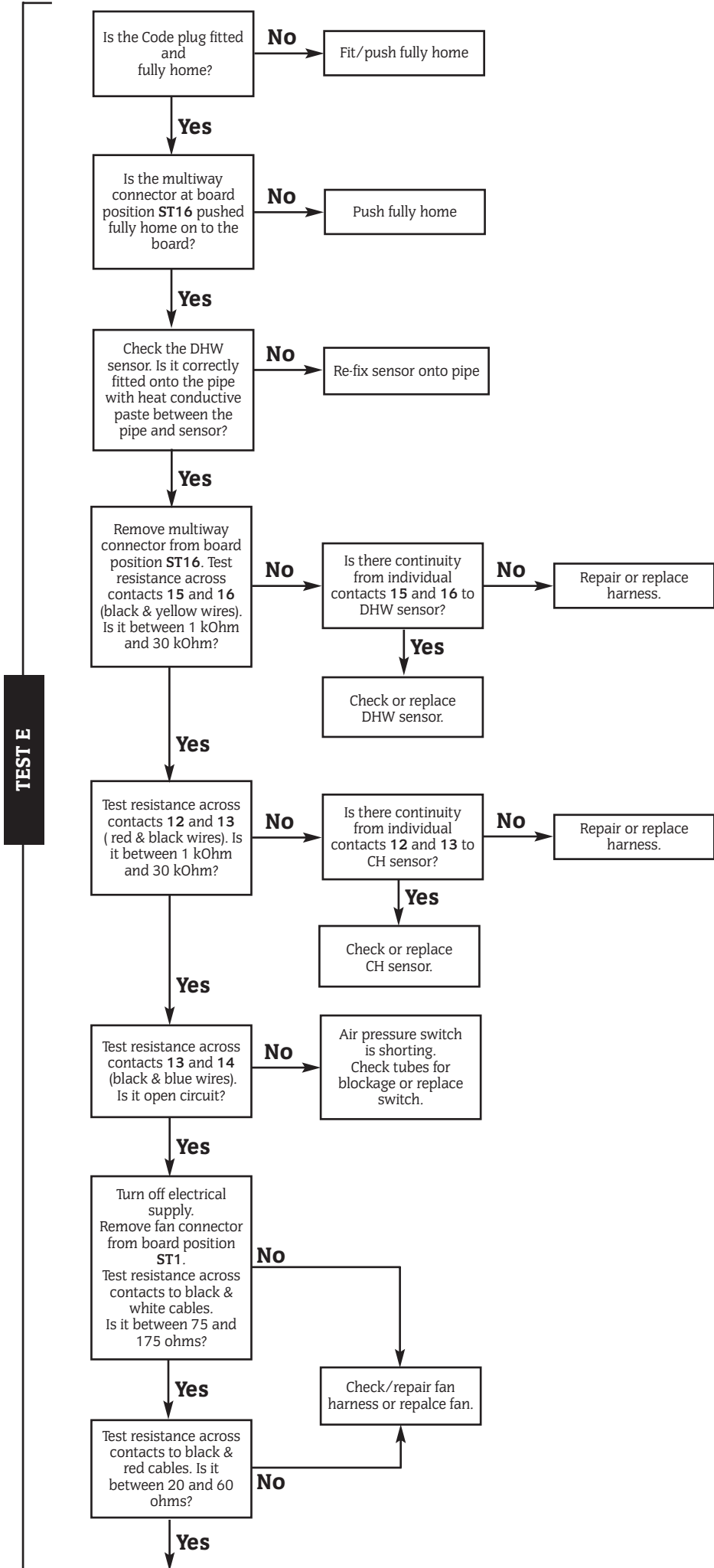

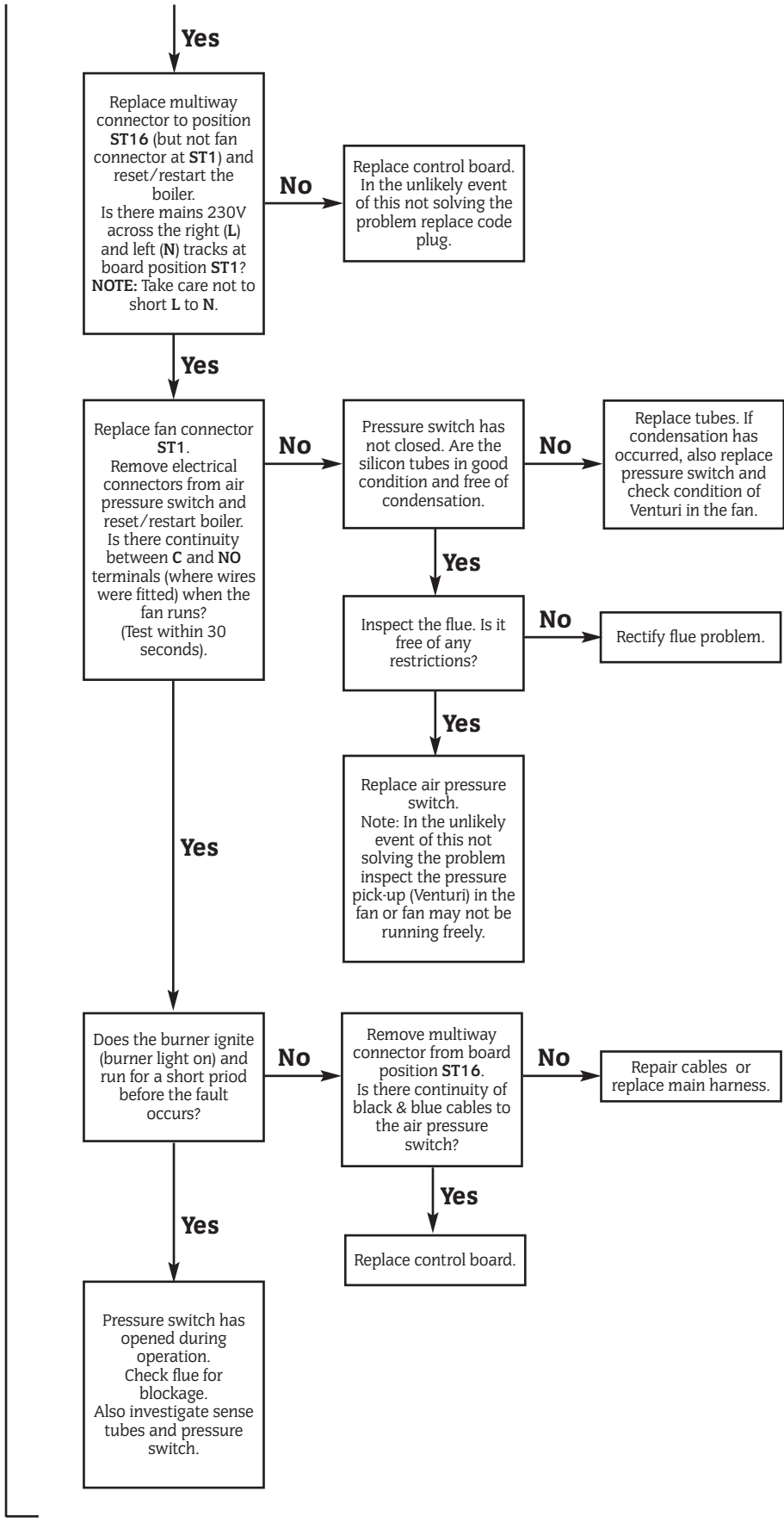

TEST F

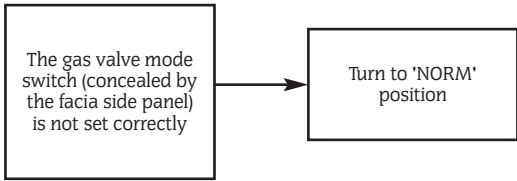

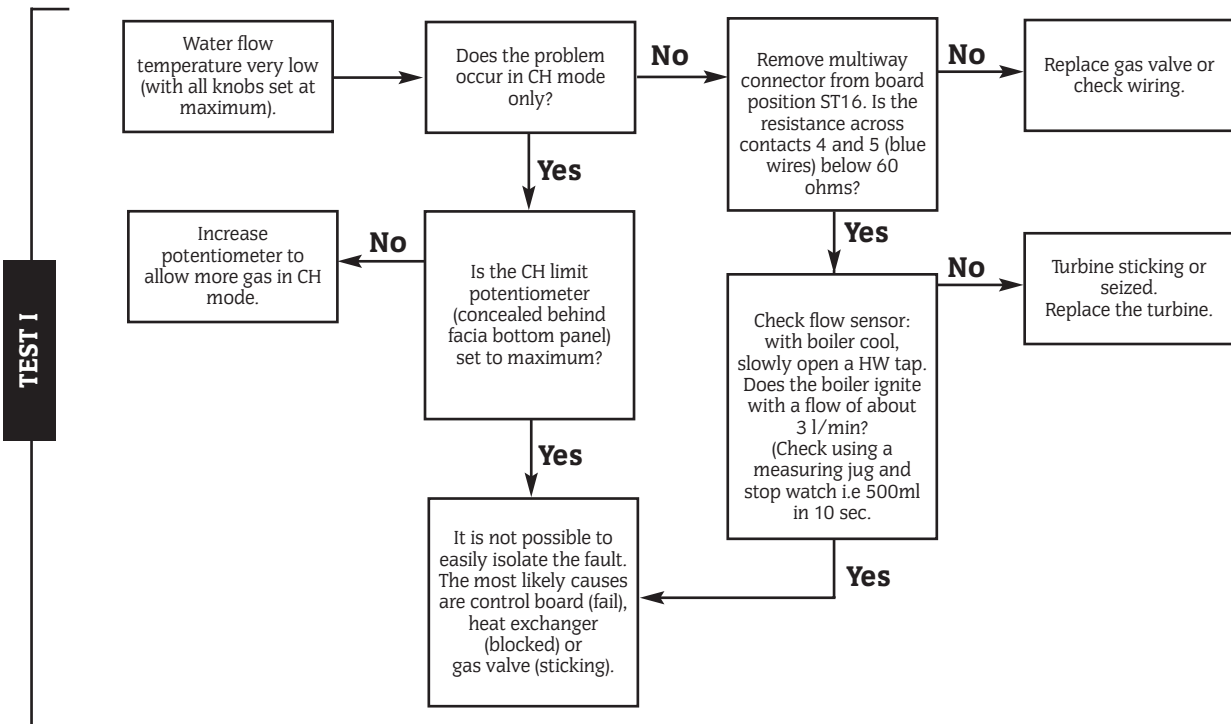
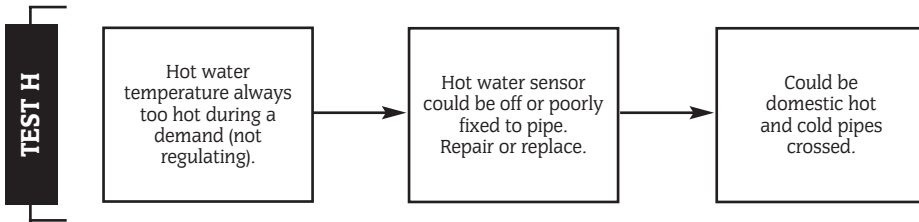
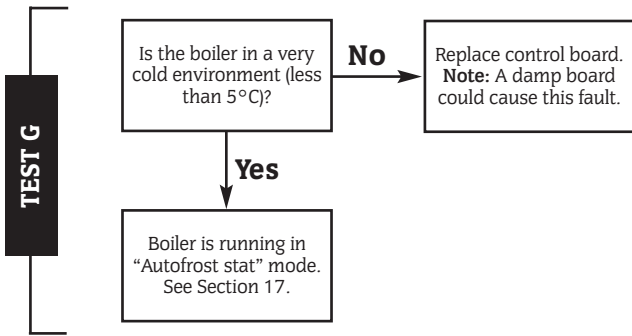

19. Conversion Instructions

ONLY COMPONENTS SUPPLIED BY WORCESTER SHOULD BE USED.

ONLY COMPETENT PERSONNEL SHOULD ATTEMPT THE CONVERSION.

CONVERSION FROM NATURAL GAS TO LPG SHOULD NOT BE CARRIED OUT ON APPLIANCES INSTALLED IN A ROOM OR INTERNAL SPACE BELOW GROUND LEVEL

	24kW	28kW
Conversion Kit NG to LPG	7 716 192 288	7 716 192 289

1. Ensure the gas service cock is turned **OFF** and the electrical supply is **ISOLATED**.
2. Refer to the Installation and Service Instructions Section 14: Inspection and Servicing to remove the cabinet front panel and outer casing.
3. Follow the dismantling instructions to remove the burner. Refer to Section: 14.3 Inspection and Servicing.
4. Remove the burner blades as shown in 15.4.
5. Replace the burner manifold with a new one supplied in the kit.
6. Refit burner blades taking care to assure that the cross lighting strip and blades are correctly fitted and aligned.
7. Remove the gas valve and replace with the gas valve supplied in the kit. Refer to the Installation and Servicing Instructions Section 15- Replacement of Parts.
NOTE: Replace the fibre washer with one of those supplied in the kit.
8. Refit the burner assembly to the gas valve using the other fibre washer supplied in the kit.
9. Ensure that the sealing grommet around the burner manifold is correctly sealed to the boiler casing.
9. Remove plastic anti-tamper seal and plastic cap from the gas valve.
10. Turn on the gas and electricity supplies and follow the commissioning procedure to confirm gas soundness and correct boiler operation.
11. Check and adjust the setting pressures to the values in Table 1 and adjust if necessary. Refer to the Installation and Service Instructions Section 12.5 for the setting of the gas valve and refer to Fig 1.

Ensure that the joints on the gas valve to the burner and inlet are both checked for gas soundness.

Table 1. 24Si II

NOMINAL BOILER RATINGS (10 Minutes After Lighting)			
BOILER ADJUSTED FOR G20 (Natural Gas)			
OUTPUT	INPUT (Net)	BURNER PRESSURE	GAS RATE
kW	kW	m bar.	m ³ /h
6.9	7.9	0.9	0.84
24	26.4	12.1	2..8
BOILER ADJUSTED FOR G31 (Propane)			
6.9	7.9	3.1	0.32
24	26.4	35.0	1.08

Natural Gas: Net Input = Gross Input x 0.901

NOTE: With longer flue lengths, not using a restrictor, the minimum burner pressure will rise, naturally due to the flue, to 1.1 mbar on G20 appliances only.

12. Refit the plastic sealing cap to the gas valve modulating valve and seal with a dab of paint or similar.
13. Turn off the boiler and when cool peel off the arrow from the data plate on the combustion box front panel and re-stick against the gas type for which the boiler has been converted and adjusted.
13. Replace the boiler front panel.

The conversion is now complete.

Fig 1. Gas Valve

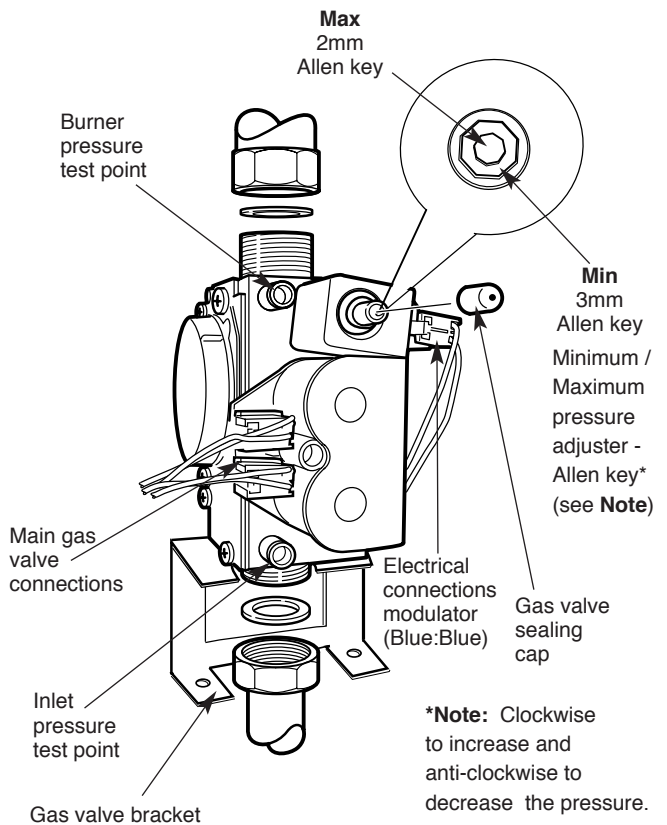

Injector sizes and markings		
	G20 Natural gas	G31LPG
24kW	1.07 mm (marked 107)	0.65 mm (marked 65)
28kW	1.12 mm (marked 113)	0.69 mm (marked 69)

Table 1. 28Si II

NOMINAL BOILER RATINGS (10 Minutes After Lighting)			
BOILER ADJUSTED FOR G20 (Natural Gas)			
OUTPUT	INPUT (Net)	BURNER PRESSURE	GAS RATE
kW	kW	m bar.	m ³ /h
8.1	9.2	0.7	0.97
28	30.7	13.1	3.25
BOILER ADJUSTED FOR G31 (Propane)			
8.1	9.2	2.8	0.38
28	30.7	34.5	1.25

LPG (Propane): Net Input = Gross Input x 0.922



GAS BOILER COMMISSIONING CHECKLIST

BOILER SERIAL No. _____ NOTIFICATION No. _____

CONTROLS To comply with the Building Regulations, each section must have a tick in one or other of the boxes

TIME & TEMPERATURE CONTROL TO HEATING	ROOM T/STAT & PROGRAMMER/TIMER <input type="checkbox"/>	PROGRAMMABLE ROOMSTAT <input type="checkbox"/>
TIME & TEMPERATURE CONTROL TO HOT WATER	CYLINDER T/STAT & PROGRAMMER/TIMER <input type="checkbox"/>	COMBI BOILER <input type="checkbox"/>
HEATING ZONE VALVES	FITTED <input type="checkbox"/>	NOT REQUIRED <input type="checkbox"/>
HOT WATER ZONE VALVES	FITTED <input type="checkbox"/>	NOT REQUIRED <input type="checkbox"/>
THERMOSTATIC RADIATOR VALVES	FITTED <input type="checkbox"/>	
AUTOMATIC BYPASS TO SYSTEM	FITTED <input type="checkbox"/>	NOT REQUIRED <input type="checkbox"/>

FOR ALL BOILERS CONFIRM THE FOLLOWING

THE SYSTEM HAS BEEN FLUSHED IN ACCORDANCE WITH THE BOILER MANUFACTURER[S] INSTRUCTIONS?

THE SYSTEM CLEANER USED _____

THE INHIBITOR USED _____

FOR THE CENTRAL HEATING MODE, MEASURE & RECORD

GAS RATE _____ m³/hr _____ tf³/hr

BURNER OPERATING PRESSURE (IF APPLICABLE) N/A _____ mbar

CENTRAL HEATING FLOW TEMPERATURE _____ °C

CENTRAL HEATING RETURN TEMPERATURE _____ °C

FOR COMBINATION BOILERS ONLY

HAS A WATER SCALE REDUCER BEEN FITTED? YES NO

WHAT TYPE OF SCALE REDUCER HAS BEEN FITTED? _____

FOR THE DOMESTIC HOT WATER MODE, MEASURE & RECORD

GAS RATE _____ m³/hr _____ tf³/hr

MAXIMUM BURNER OPERATING PRESSURE (IF APPLICABLE) N/A _____ mbar

COLD WATER INLET TEMPERATURE _____ °C

HOT WATER OUTLET TEMPERATURE _____ °C

WATER FLOW RATE _____ l/s/min

FOR CONDENSING BOILERS ONLY CONFIRM THE FOLLOWING

THE CONDENSATE DRAIN HAS BEEN INSTALLED IN ACCORDANCE WITH THE MANUFACTURER[S] INSTRUCTIONS? YES

FOR ALL INSTALLATIONS CONFIRM THE FOLLOWING

THE HEATING AND HOT WATER SYSTEM COMPLIES WITH CURRENT BUILDING REGULATIONS

THE APPLIANCE AND ASSOCIATED EQUIPMENT HAS BEEN INSTALLED AND COMMISSIONED IN ACCORDANCE WITH THE MANUFACTURER[S] INSTRUCTIONS

IF REQUIRED BY THE MANUFACTURER, HAVE YOU RECORDED A CO/CO₂ RATIO READING? N/A YES _____ CO/CO₂ RATIO

THE OPERATION OF THE APPLIANCE AND SYSTEM CONTROLS HAVE BEEN DEMONSTRATED TO THE CUSTOMER

THE MANUFACTURER[S] LITERATURE HAS BEEN LEFT WITH THE CUSTOMER

COMMISSIONING ENG[S] NAME PRINT _____ CORGI ID No. _____

SIGN _____ DATE _____

SERVICE INTERVAL RECORD

It is recommended that your heating system is serviced regularly and that you complete the appropriate Service Interval Record Below.

Service Provider. Before completing the appropriate Service Interval Record below, please ensure you have carried out the service as described in the boiler manufacturer's instructions. Always use the manufacturer's specified spare part when replacing all controls

SERVICE 1 DATE

ENGINEER NAME _____
COMPANY NAME _____
TEL No. _____
CORGI ID CARD SERIAL No. _____
COMMENTS _____
SIGNATURE _____

SERVICE 2 DATE

ENGINEER NAME _____
COMPANY NAME _____
TEL No. _____
CORGI ID CARD SERIAL No. _____
COMMENTS _____
SIGNATURE _____

SERVICE 3 DATE

ENGINEER NAME _____
COMPANY NAME _____
TEL No. _____
CORGI ID CARD SERIAL No. _____
COMMENTS _____
SIGNATURE _____

SERVICE 4 DATE

ENGINEER NAME _____
COMPANY NAME _____
TEL No. _____
CORGI ID CARD SERIAL No. _____
COMMENTS _____
SIGNATURE _____

SERVICE 5 DATE

ENGINEER NAME _____
COMPANY NAME _____
TEL No. _____
CORGI ID CARD SERIAL No. _____
COMMENTS _____
SIGNATURE _____

SERVICE 6 DATE

ENGINEER NAME _____
COMPANY NAME _____
TEL No. _____
CORGI ID CARD SERIAL No. _____
COMMENTS _____
SIGNATURE _____

SERVICE 7 DATE

ENGINEER NAME _____
COMPANY NAME _____
TEL No. _____
CORGI ID CARD SERIAL No. _____
COMMENTS _____
SIGNATURE _____

SERVICE 8 DATE

ENGINEER NAME _____
COMPANY NAME _____
TEL No. _____
CORGI ID CARD SERIAL No. _____
COMMENTS _____
SIGNATURE _____

SERVICE 9 DATE

ENGINEER NAME _____
COMPANY NAME _____
TEL No. _____
CORGI ID CARD SERIAL No. _____
COMMENTS _____
SIGNATURE _____

SERVICE 10 DATE

ENGINEER NAME _____
COMPANY NAME _____
TEL No. _____
CORGI ID CARD SERIAL No. _____
COMMENTS _____
SIGNATURE _____

This manual is to be used in conjunction with the variant part number of the bar code below:



8716105781

www.worcester-bosch.co.uk



Worcester, Bosch Group, Cotswold Way, Warndon, Worcester WR4 9SW.

Telephone: 01905 754624. Fax: 01905 753130.

Technical Helpline 08705 266241.

Worcester, Bosch Group is a trading name of BBT Thermotechnology UK Limited.

This booklet is accurate at the date of printing but will be superseded and should be disregarded if specifications and/or appearances are changed in the interests of continued improvement.

All goods sold are subject to our official Conditions of Sale, a copy of which may be obtained on application.

PUBLICATION 8 716 114 750a (11/07)