

INSTRUCTION MANUAL

INSTALLATION, COMMISSIONING & SERVICING

WALL HUNG RSF GAS FIRED CONDENSING COMBINATION BOILER

GREENSTAR 24i junior / 28i junior

FOR SEALED CENTRAL HEATING SYSTEMS AND MAINS FED
DOMESTIC HOT WATER

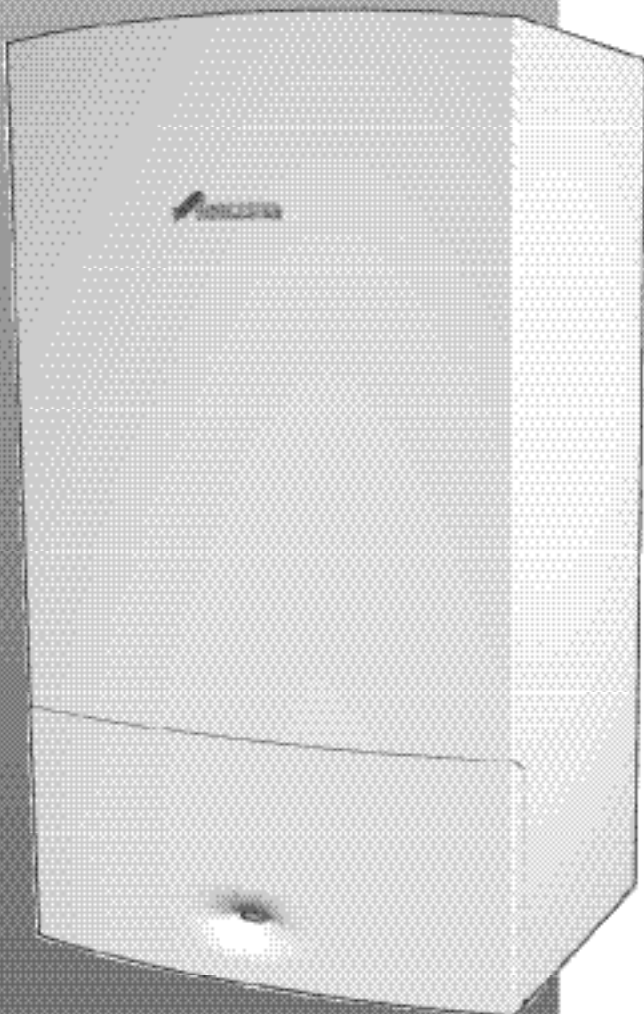

THE APPLIANCE IS FOR USE WITH
NATURAL GAS OR L.P.G. (Cat II 2H3P TYPE C13, C33 & C53)

NATURAL GAS:

24i junior GC NUMBER 47-311-86

28i junior GC NUMBER 47-311-87

LIQUID PETROLEUM GAS:

24i junior GC NUMBER 47-311-90

28i junior GC NUMBER 47-311-91

UK/IE

benchmark

WORCESTER
Bosch Group

SYMBOLS USED IN THIS MANUAL:



Domestic hot water



Central heating



Hot water storage cylinder



Cold water main supply



Electricity supply



Gas supply

LIFTING AND CARRYING PRECAUTIONS:

- Lift only a manageable weight, or ask for help.
- When lifting the boiler, bend the knees, and keep the back straight and feet apart.
- Do not lift and twist at the same time.
- Lift and carry the boiler close to the body
- Wear protective clothing and gloves to protect from any sharp edges

WATER TREATMENT:

FERNOX 01799 550811

www.fernox.com

SENTINEL 0800 389 4670

www.sentinel-solutions.net

FLUE TERMINAL GUARDS:

TOWER FLUE COMPONENTS LTD.

Vale Rise, Tonbridge TN9 1TB

01732 351555

PLEASE READ THESE INSTRUCTIONS CAREFULLY BEFORE STARTING INSTALLATION.

THESE INSTRUCTIONS ARE APPLICABLE TO THE WORCESTER APPLIANCE MODEL(S) STATED ON THE FRONT COVER OF THIS MANUAL ONLY AND MUST NOT BE USED WITH ANY OTHER MAKE OR MODEL OF APPLIANCE.

THE INSTRUCTIONS APPLY IN THE UK/IE ONLY AND MUST BE FOLLOWED EXCEPT FOR ANY STATUTORY OBLIGATION.

THIS APPLIANCE MUST BE INSTALLED BY A CORGI REGISTERED, COMPETENT PERSON. FAILURE TO INSTALL CORRECTLY COULD LEAD TO PROSECUTION.

IF YOU ARE IN **ANY DOUBT** CONTACT THE WORCESTER TECHNICAL HELPLINE.

DISTANCE LEARNING AND TRAINING COURSES ARE AVAILABLE FROM WORCESTER.

PLEASE LEAVE THESE INSTRUCTIONS WITH THE COMPLETED BENCHMARK CHECKLIST, (OR A CERTIFICATE CONFIRMING COMPLIANCE WITH IS 813, EIRE ONLY) AND THE USER MANUAL WITH THE OWNER OR AT THE GAS METER AFTER INSTALLATION OR SERVICING. THE BENCHMARK CHECKLIST CAN BE FOUND IN THE BACK TWO PAGES OF THE INSTALLATION MANUAL.

ABBREVIATIONS USED IN THIS MANUAL:

∅	Diameter
NG	Natural Gas
LPG	Liquid Petroleum Gas
CH	Central Heating
DHW	Domestic Hot Water
IP	Ingress Protection
SEDBUK	Seasonal Efficiency of Domestic Boilers in the United Kingdom

CONTENTS

SAFETY & REGULATIONS

INSTALLATION AND SERVICING INSTRUCTIONS	2
SAFETY PRECAUTIONS & SYMBOLS	4
INSTALLATION REGULATIONS	4

APPLIANCE INFORMATION

GENERAL INFORMATION	5
TECHNICAL DATA	6
LAYOUT & COMPONENTS	7

PRE-INSTALLATION

CLEANING PRIMARY SYSTEMS	9
MAINS SUPPLY	10
WATER SYSTEMS & PIPEWORK	11
CONDENSATE PIPEWORK	12
PRESSURE RELIEF PIPEWORK	13
BOILER LOCATION & CLEARANCES	14
PLUMBING MANIFOLD	16
FLUE OPTIONS	17
FLUE TERMINAL POSITIONS	18

INSTALLATION

UNPACKING THE WALL FRAME	20
WALL MOUNTING TEMPLATE / FLUE OPENING	21
UNPACKING THE APPLIANCE	22
BOILER CONNECTIONS	23
FLUE INSTALLATION	25
CONDENSATE CONNECTIONS	28
ELECTRICS	29
POSITION OF WIRED COMPONENTS	30

COMMISSIONING

PRE-COMMISSIONING CHECKS	31
FILLING THE SYSTEM	32
STARTING THE APPLIANCE	33
WATER TREATMENT	34
COMMISSIONING	35
FINISHING COMMISSIONING	36

SERVICING & SPARES

INSPECTION AND SERVICE	37
REPLACEMENT OF PARTS	43
SETTING THE AIR/GAS RATIO	55
SHORT PARTS LIST	56

CONVERSION KITS

L.P.G. CONVERSION	57
-------------------	----

FAULT FINDING & DIAGNOSIS

FAULT FINDING	58
CENTRAL HEATING FUNCTION	59
PREHEAT AND DHW FUNCTION	60
PROTECTION FUNCTION	61
BENCHMARK CHECKLIST	
SERVICE INTERVAL RECORD SHEET	

SAFETY &
REGULATIONS

APPLIANCE
INFORMATION

PRE -
INSTALLATION

INSTALLATION

COMMISSIONING

SERVICING
& SPARES

CONVERSION
KITS

FAULT FINDING
& DIAGRAMS

SAFETY PRECAUTIONS

IF YOU SMELL GAS:

- X **DON'T** SMOKE OR STRIKE MATCHES
- X **DON'T** TURN ELECTRICAL SWITCHES ON OR OFF
- ✓ **DO** PUT OUT NAKED FLAMES
- ✓ **DO** OPEN DOORS AND WINDOWS
- ✓ **DO** KEEP PEOPLE AWAY FROM THE AREA AFFECTED
- ✓ **DO** TURN OFF THE CONTROL VALVE AT THE METER
- ✓ **DO** CALL YOUR GAS COMPANY



A Benchmark Checklist is provided by Worcester, Bosch Group, at the back of this manual, for the installer to complete. The checklist will include their CORGI registration number to confirm that the boiler has been installed, commissioned and serviced according to the manufacturer's instructions.

IMPORTANT: The completed Benchmark Checklist will be required in the event of any warranty work and may be required by the local Building Control Inspector.

HEALTH & SAFETY

The appliance contains no asbestos and no substances have been used in the construction process that contravene the COSHH Regulations (Control of Substances Hazardous to Health Regulations 1988).

COMBUSTIBLE AND CORROSIVE MATERIALS

Do not store or use any combustible materials (paper, thinners, paints etc.) inside or within the vicinity of the appliance.

Chemically aggressive substances, can corrode the appliance and invalidate any warranty.

FITTING & MODIFICATIONS

Fitting the appliance and any controls to the appliance may only be carried out by a competent engineer in accordance with the current Gas Safety (Installation and Use) Regulations.

Flue systems must not be modified in any way other than as described in the fitting instructions. Any misuse or unauthorised modifications to the appliance, flue or associated components and systems will invalidate the warranty. The manufacturer accepts no liability arising from any such actions, excluding statutory rights.

SERVICING

Advise the user to have the system serviced annually by a competent, qualified engineer (such as British Gas or other CORGI registered personnel) using approved spares, to help maintain the economy, safety and reliability of the appliance.

IMPORTANT - The service engineer must complete the Service Record on the Benchmark Checklist after each service.

INSTALLATION REGULATIONS

Current Gas Safety (Installation & Use) Regulations:

All gas appliances must be installed by a competent person in accordance with the above regulations. Failure to install appliances correctly could lead to prosecution.

The appliance must be installed in accordance with, and comply to, the current: Gas Safety Regulations, IEE Regulations, Building Regulations, Building Standards (Scotland) (Consolidation), Building Regulations (Northern Ireland), local water by-laws, Health & Safety Document 635 (The Electricity at Work Regulations 1989) and any other local requirements.

British Standards:

The relevant British Standards should be followed, including:

BS7074:1 : Code of practice for domestic and hot water supply

BS6891 : Installation of low pressure gas pipework up to 28mm (R1)

BS5546 : Installation of gas hot water supplies for domestic purposes

EN:12828 : Central heating for domestic premises

BS5440:1 : Flues and ventilation for gas appliances of rated heating not exceeding 70kW (net) : Flues

BS5440:2 : Flues and ventilation for gas appliances of rated heating not exceeding 70kW (net) : Air Supply

BS7593 : Treatment of water in domestic hot water central heating systems

BS 6798 : Installation of gas fired boilers of rated input up to 70kW (net)

Where no specific instruction is given, reference should be made to the relevant British Standard codes of Practice.

L.P.G. Installation:

An appliance using L.P.G. must not be installed in a room or internal space below ground level unless one side of the building is open to the ground.

Timber framed buildings:

Where the boiler is to be fitted to a timber framed building the guidelines laid down in BS5440: Part 1 and IGE "Gas Installations in Timber Frame Buildings" should be adhered to.

Potable water:

All seals, joints and compounds (including flux and solder) and components used as part of the secondary domestic water system must be approved by WRAS.

IMPORTANT: ARTIFICIALLY SOFTENED WATER MUST NOT BE USED TO FILL THE CENTRAL HEATING SYSTEM

(When fitted to wall frame)
Depth to wall

GENERAL INFORMATION

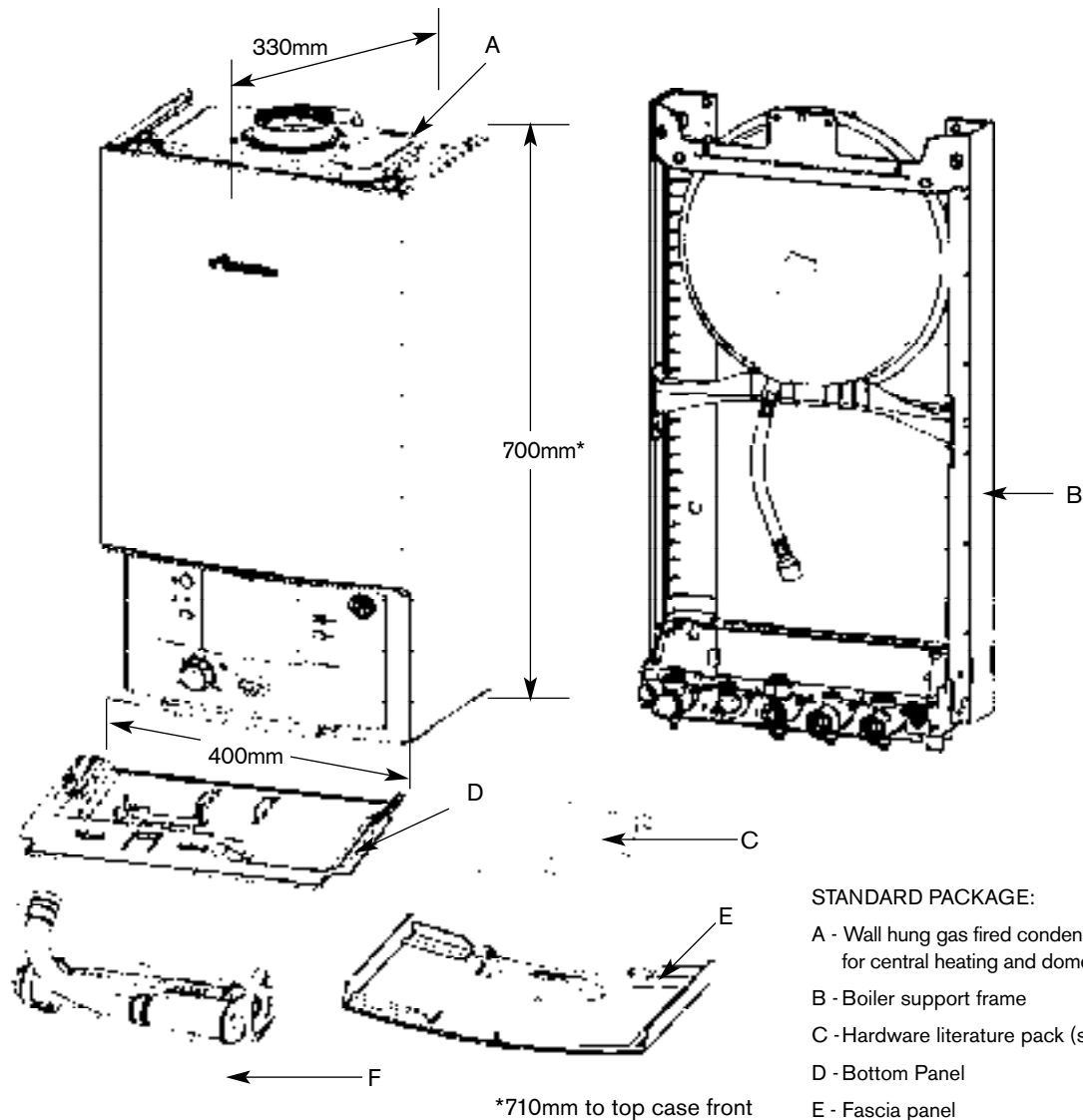

STANDARD PACKAGE:

- A - Wall hung gas fired condensing combi boiler for central heating and domestic hot water
- B - Boiler support frame
- C - Hardware literature pack (see checklist)
- D - Bottom Panel
- E - Fascia panel
- F - Syphon assembly

SPECIFICATIONS:

- Pre-wired and pre-plumbed
- Galvanised steel inner frame
- Digital control system
- Automatic ignition
- Direct burner ignition electrodes
- Built-in frost thermostat
- Built-in fault finding diagnostics
- Modulating automatic gas valve
- Combustion air fan with speed regulator
- CH temperature sensor & control
- Pump anti-seizure protection
- Flue gas temperature limiter
- Condensate trap & syphon
- DHW flow sensor & temperature control
- Plate type DHW heat exchanger

Check List

Hardware/Literature pack

Item	Qty.
Greenstar 24i Junior/28i Junior Installation/Serviceing Instructions.....	1
Users Instructions	1
Consumer Guarantee Card	1
Syphon assembly.....	1
Installation instructions.....	1
Sealing Pack	1
Compression Nut 22mm	3
Compression Ring 22mm	3
Compression Nut 15mm	3
Compression Ring 15mm	3
Fibre Washer 18.6 x 13.5 x 1.5	2
Fibre Washer 23.9 x 17.2 x 1.5.....	2
Bonded Washer 3/4	1
Syphon assembly.....	1
Installation instructions.....	1
Irish Guidelines Leaflet	1
Warranty Return Envelope	1

DESCRIPTION	UNIT	NATURAL GAS		L.P.G.	
		24 iJunior	28 iJunior	24 iJunior	28 iJunior
Domestic Hot Water					
Min. heat input	KW	7.38	7.38	9.64	9.64
Max. rated heat output	KW	24	28	24	28
Max. rated heat input	KW	24.49	28.57	24.49	28.57
Gas flow rate - Max. 10 minutes from lighting					
Natural Gas G20	m ³ /h	2.59	3.02	-	-
Propane Gas (LPG)	kg/h	-	-	1.9	2.22
Max. mains inlet pressure	bar	10	10	10	10
Min. mains inlet pressure (working) for max flow	bar	1.3	1.3	1.3	1.3
Min. mains inlet pressure (working) for operation	bar	0.2	0.2	0.2	0.2
Domestic Hot Water temperature setting	°C	55	55	55	55
Domestic Hot Water specific rate - 30°C rise	l/min	11.5	13.4	11.5	13.4
Max. Domestic Hot Water flow rate - 40°C rise +/- 15%	l/min	8.6	10	8.6	10
Central Heating					
Max. rated heat input	KW	24.62	24.62	24.62	24.62
Max. rated heat output 40/30°C	KW	25.67	25.67	25.67	25.67
Max. rated heat output 50/30°C	KW	25.45	25.45	25.45	25.45
Max. rated heat output 80/60°C	KW	24	24	24	24
Max. flow temperature	°C	82	82	82	82
Max. permissible operating pressure	bar	2.5	2.5	2.5	2.5
Available pump head at 21°C system temperature rise	m	2.0	2.0	2.0	2.0
Flue					
Flue Gas Temp. 80/60°C, rated/min. load	°C	78/63	78/64	79/64	79/65
Flue Gas Temp. 40/30°C, rated min. load	°C	54/35	54/36	55/38	55/39
CO ₂ level at max. rated heat output (after 30 mins)	%	9.8	9.8	11.0	11.0
CO ₂ level at min. rated heat output (after 30 mins)	%	9.2	9.2	10.5	10.5
NO _x - class		5	5	5	5
Condensate					
Max. condensation rate	l/h	2.0	2.0	2.0	2.0
pH value, approx.		4.8	4.8	4.8	4.8
Electrical					
Electrical power supply voltage	AC...V	230	230	230	230
Frequency	Hz	50	50	50	50
Max. power consumption	W	140	140	140	140
General Data					
SEDBUK	band	A	A	A	A
Appliance protection rating	IP	X4D	X4D	X4D	X4D
Appliance protection rating with mechanical or RF mechanical timer fitted	IP	20	20	20	20
Permissible ambient temperatures	°C	0-50	0-50	0-50	0-50
Nominal capacity of appliance	ltr	3.9	3.9	3.9	3.9
Noise output level (Max central heating)	dB(A)	42	42	42	42
Total boiler weight	kg	39.5	39.5	39.5	39.5
Lift weight	kg	27.1	27.1	27.1	27.1
SEDBUK	%	90.1	90.1	91.8	91.8

LAYOUT & COMPONENTS

The diagram opposite shows the controls in the servicing position and excludes the outer case.

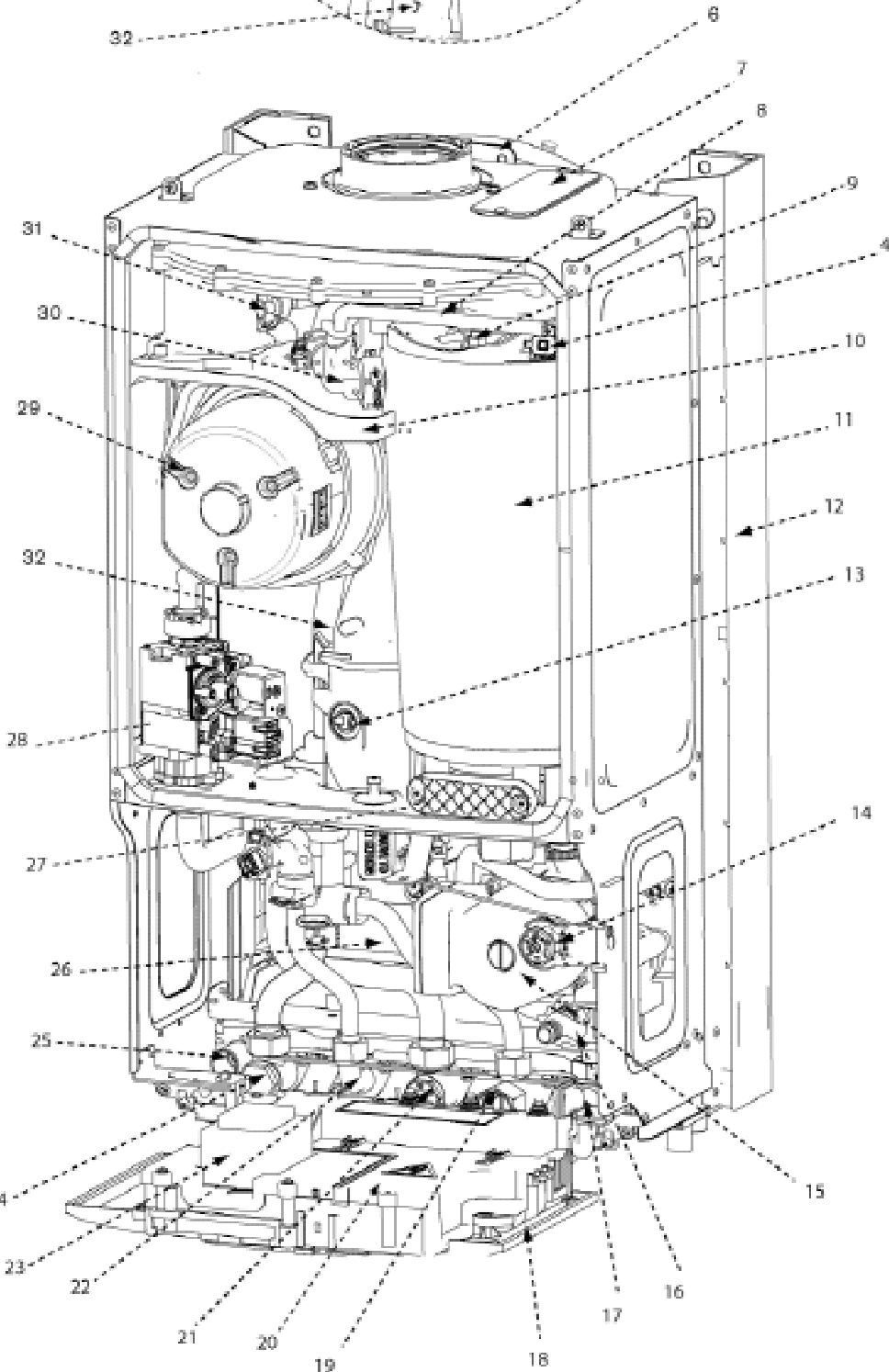
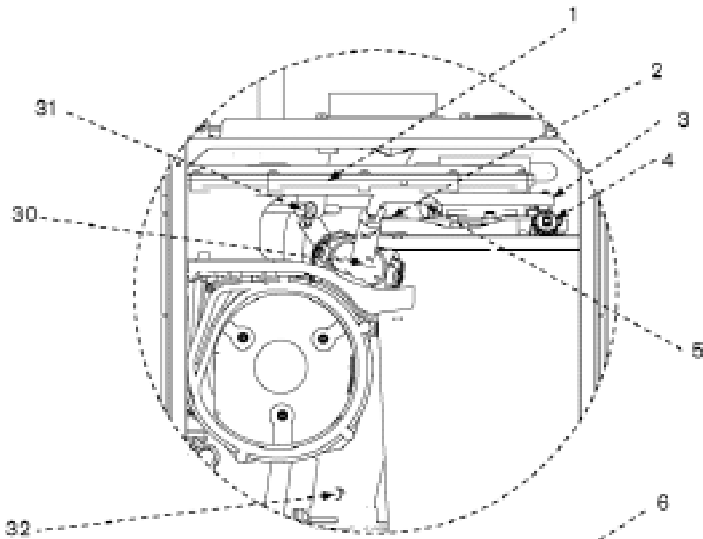

- 1 AIR / GAS MANIFOLD
- 2 SENSOR - BOILER FLOW
- 3 IGNITION AND FLAME SENSE ELECTRODES
- 4 OVERHEAT THERMOSTAT
- 5 RETAINING BRACKET
- 6 EXPANSION VESSEL
- 7 REMOVABLE PANEL FOR SERVICING
- 8 SILICONE TUBE (HEAT EXCHANGER AIR VENT)
- 9 SECURING NUT, AIR / GAS MANIFOLD CLAMP
- 10 FAN DRIP GUARD
- 11 HEAT EXCHANGER
- 12 WALL MOUNTING FRAME
- 13 FLUE OVERHEAT THERMOSTAT
- 14 SYSTEM PRESSURE GAUGE
- 15 PUMP
- 16 DRAIN POINT
- 17 CH RETURN
- 18 CONTROL PANEL IN SERVICE POSITION
- 19 MAINS COLD WATER IN
- 20 COVER FOR EXTERNAL WIRING CONNECTIONS
- 21 GAS INLET CONNECTION 22mm COMPRESSION
- 22 DHW OUT
- 23 ACCESS COVER FOR TRANSFORMER & PCB
- 24 CH FLOW
- 25 SYPHON OUTLET CONNECTION (22mm PLASTIC PIPE)
- 26 PLATE TO PLATE DHW HEAT EXCHANGER
- 27 ACCESS POINT FOR CLEANING HEAT EXCHANGER/SUMP
- 28 GAS VALVE
- 29 FAN
- 30 MANUAL VENT POINT
- 31 FAN PRESSURE TEST POINT
- 32 FLUE AIR PRESSURE SWITCH CONNECTION (BLANKED OFF ON THIS APPLIANCE)

LAYOUT & COMPONENTS

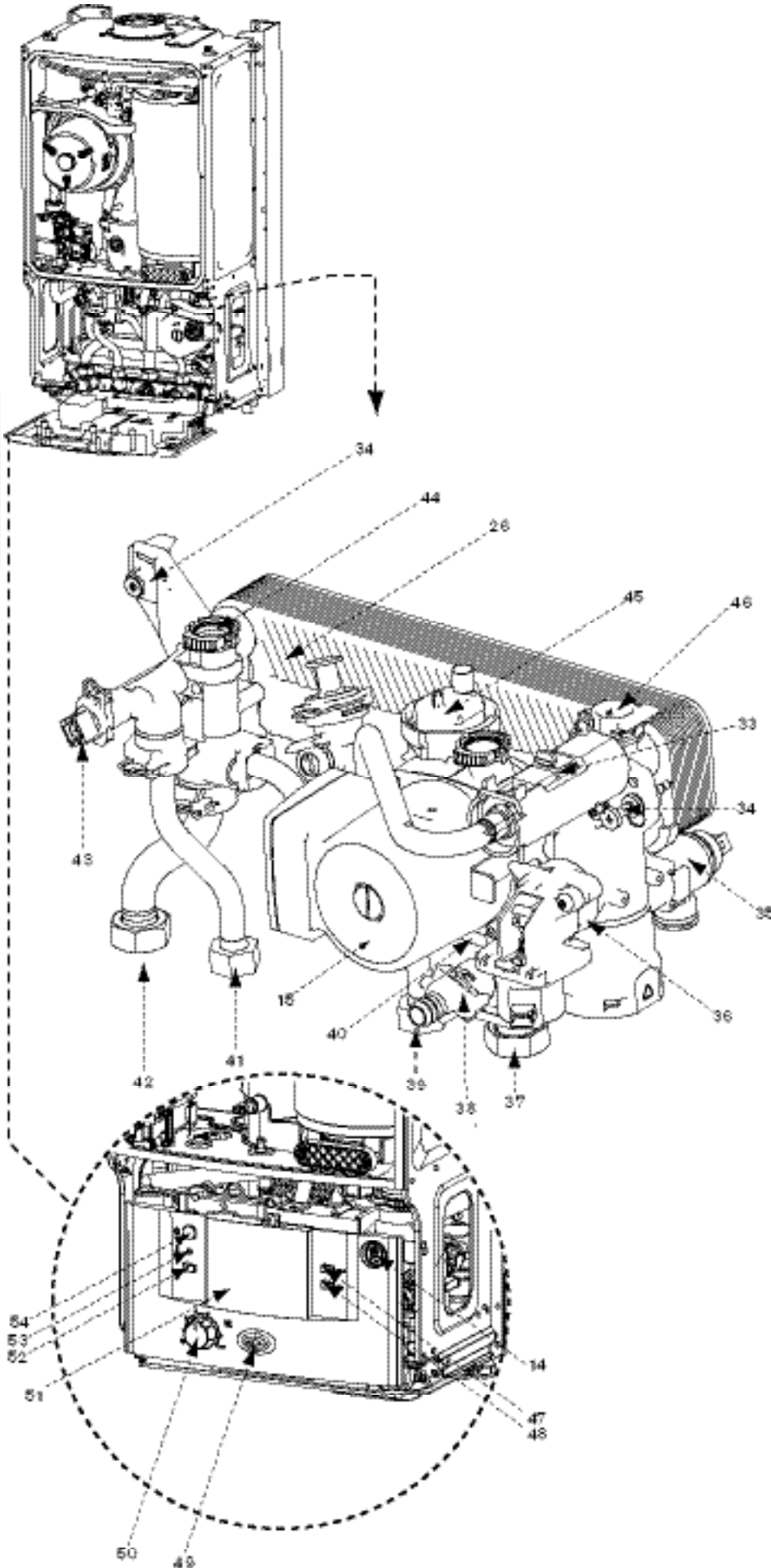

- 14 SYSTEM PRESSURE GAUGE
- 15 SYSTEM PUMP
- 26 PLATE TO PLATE DHW HEAT EXCHANGER
- 33 FLOW TURBINE
- 34 COMPACT HYDRAULIC MOUNTING SCREW (2) TO BOILER
- 35 PRESSURE RELIEF VALVE
- 36 DIVERTER VALVE
- 37 CH RETURN CONNECTION TO SERVICE VALVE
- 38 DRAIN TAP
- 39 COLD WATER IN CONNECTION
- 40 INTERNAL BYPASS WITHIN PLASTIC MOULDING
- 41 DHW OUT CONNECTION
- 42 CH FLOW CONNECTION TO SERVICE VALVE
- 43 DHW SENSOR
- 44 FLOW CONNECTION FROM BOILER HEAT EXCHANGER
- 45 AUTO AIR VENT
- 46 UNUSED PORT
- 47 FAULT RESET BUTTON
- 48 ECO BUTTON
- 49 MAINS ON/OFF INDICATOR/ DIAGNOSTIC LIGHT (BLUE)
- 50 CH TEMPERATURE CONTROL
- 51 POSITION FOR OPTIONAL PROGRAMMER
- 52 SERVICE MODE BUTTON
- 53 BURNER ON INDICATOR LIGHT (GREEN)
- 54 MASTER SWITCH ON/OFF

IMPORTANT: All the following Pre-Installation sections must be read and requirements met before starting boiler or flue installation.

CAUTION: ISOLATE THE MAINS SUPPLIES BEFORE STARTING ANY WORK AND OBSERVE ALL RELEVANT SAFETY PRECAUTIONS.

CLEANING PRIMARY SYSTEMS

IMPORTANT: Debris from the system can damage the boiler and reduce efficiency. Failure to comply with the guidelines for the use of water treatment with the appliance will invalidate the appliance warranty.

**BEFORE CLEANING THE SYSTEM:
ENSURE THE SYSTEM AND PIPEWORK IS IN GOOD WORKING ORDER**

WHERE POSSIBLE KEEP THE EXISTING BOILER/CIRCULATING PUMP IN PLACE WHEN FLUSHING THE SYSTEM.

**FOLLOW GUIDANCE OF BS7593:
TREATMENT OF WATER IN DOMESTIC HOT WATER CENTRAL HEATING AND ALSO FLUSHING GUIDELINES SET OUT BELOW.**

CLEANING THE PRIMARY SYSTEM:

IMPORTANT: ARTIFICIALLY SOFTENED WATER MUST NOT BE USED TO FILL THE CENTRAL HEATING SYSTEM

- Fill the system with cold water and check for leaks.
- Open all drain cocks and drain the system.
- Close drain cocks and add a suitable flushing agent **compatible with aluminium** at the correct strength for the system condition in accordance with the manufacturer's instructions.
The PH value of the system water must be less than 8 or the appliance guarantee will be invalidated.
- Circulate the flushing agent before the boiler is fired up.
- Run the boiler/system at normal operating temperature as directed by the manufacturer of the flushing agent.
- Drain and thoroughly flush the system to remove the flushing agent and debris.
- It may be necessary to use a power flushing machine to aid the cleansing procedure in some circumstances

MAINS SUPPLY

ELECTRIC SUPPLY:

- Supply: 230V - 50Hz, 140 watts
- Cable: PVC insulated 0.75mm² (24 x 0.2mm) temperature rated to 90°C.
- External 3A fuse to BS1362.
- The appliance must be earthed.
- This appliance must not be connected to a three phase supply.
- IPX4D.

NOTE: this is reduced to IP20 if the following mechanical timers are fitted:
7 716 192 036 or 7 716 192 037.

- Wiring must comply with latest IEE wiring regulations.

GAS SUPPLY:

- Boilers using NG must be connected to a governed meter.
- LPG boilers must be connected to a regulator.
- Installation and connection of the gas supply to the boiler must be in accordance with BS6891.
- Under no circumstances should the size of the gas supply pipe be less than that of the appliance inlet connection.
- The meter or regulator and pipework to the meter must be checked, preferably by the gas supplier, to ensure it is in good working order and can meet the gas flow and pressure requirements in addition to the demand from any other appliance being served.

WATER SUPPLY:

Water mains pressure:

- Minimum mains water pressure 1.3 bar for maximum performance.
- Maximum mains fed water pressure 10 bar. If necessary, fit a pressure reducing valve.

IMPORTANT: Non-return, back flow prevention devices (including those associated with water meters) fitted to the mains water supply can cause a pressure build up which could damage the boiler and other household appliances.

- Where the mains water supply has a non-return, back flow prevention valve fitted, a mini expansion vessel (A) should be connected to the mains water inlet pipe (B) between the non-return valve (C) and the boiler (D) as shown opposite.

Use in hard water areas:

Normally there is no need for water treatment to prevent scale formation as the maximum temperature of the DHW heat exchanger is limited in the electronic circuit.

In areas where temporary water hardness exceeds 200ppm, consideration may need to be given to the fitting of a scale prevention device. In such circumstances, the advice of the local water authority should be sought.

MAINS WATER EXPANSION VESSEL:

- A - Mini expansion vessel, part No. 7 716 102 105
- B - Mains water inlet
- C - Non-return valve
- D - Boiler

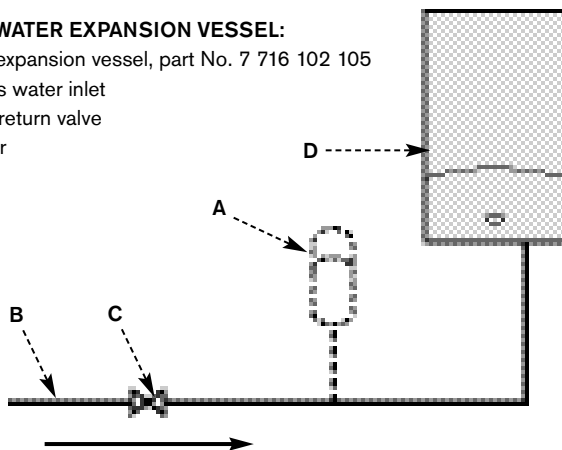

PLASTIC PIPEWORK:

- Any plastic pipework must have a polymeric barrier with 600mm (minimum) length of copper pipe connected to the boiler.
- Plastic pipework used for underfloor heating must be correctly controlled with a thermostatic blending valve limiting the temperature of the circuits to approx. 50°C.

PRIMARY SYSTEMS CONNECTIONS/VALVES:

- All system connections, taps and mixing valves must be capable of sustaining a pressure up to 3 bar.
- Radiator valves should conform to BS2767:10.
- All other valves should conform to BS1010.
- Thermostatic radiator valves (TRV's) must be used on all radiators within the sleeping accommodation but not the radiator where the room thermostat is sited. This must be fitted with lockshield valves and left open.
- A drain cock is required at the lowest point in the system.
- An air vent is required at all the high points in the system.

NOTE: The boiler is equipped with an automatic internal by-pass.

SHOWERS/BIDETS:

- If a shower head can be immersed in water or comes closer than 25mm from the top edge of a bath or shower tray spill over level then an anti-syphon device must be fitted to the shower hose.
- Bidets with direct hot and cold mains water can be used (with the approval of the local water authority) and must be the over rim flushing type with shrouded outlets to prevent the fitting of hand held sprays.

IMPORTANT: ARTIFICIALLY SOFTENED WATER MUST NOT BE USED TO FILL THE CENTRAL HEATING SYSTEM

SEALED PRIMARY SYSTEM:

- The CH sealed system must be filled using a WRAS approved filling loop or comply with the diagram opposite for system fill.
- Where the system volume is more than 100 litres or exceeds 2.65 bar at maximum heating temperature, an extra expansion vessel (B) must be fitted as close as possible to the appliance in the central heating return.
- Pressurise the extra expansion vessel (B) to the same figure as the expansion vessel built into the appliance.
- **Do not use galvanised pipes or radiators.**

SYSTEM FILL

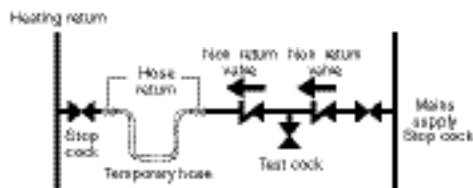

TYPICAL SEALED SYSTEM

- A - Appliance expansion vessel - central heating
- B - Extra expansion vessel - central heating return
- C - Drain cock
- P - Pressure relief discharge
- R - Radiators

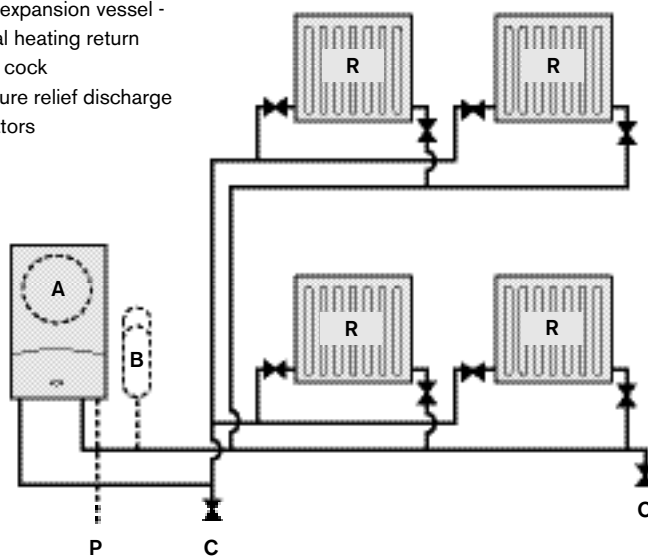

CONDENSATE PIPEWORK

IMPORTANT:

- Ensure there are no blockages in the pipe run
- Care should be taken when siting a soak-away to avoid obstructing existing services
- Condensate waste must not be terminated into a septic tank or cesspit

CONDENSATE PIPEWORK:

- The condensate pipe must be a minimum of 22 mm Ø plastic pipe.
- The condensate pipework must fall at least 50 mm per metre towards the outlet and should take the shortest practicable route.
- The pipework must follow one of the options shown opposite or discharge directly into a vent stack min. 450 mm above pipe invert or into a gully below ground but above the water level.
- Wherever possible the condensate discharge pipe work should be routed and terminated internally. Should this not be possible, and the only available route is external, the following conditions should be observed:

External pipe work

- Pipe work length should be kept to a minimum and the route as vertical as possible.
- Where pipe work is subjected to extreme cold or wind chill, a weather proof insulation should be used.

Alternatively the condensate pipework could be increased to a minimum diameter of 32 mm without the requirement to insulate.

Condensate soakaway

The condensate drainage pipe may be run above or below the ground to the soakaway. The example shown opposite runs above ground level.

The soakaway must use a 100mm diameter plastic tube with two rows of three 12 mm holes on 25 mm centres and 50 mm from the bottom of the tube. The holes must face away from the house.

The tube must be surrounded by at least 100 mm of limestone chippings to a depth of 400mm.

Fitting an external air break

Use the situation opposite when a rain water down pipe is used to dispose of condensate and the down pipe goes directly into an existing sewer that carries both rainwater and foul water.

An air break must be installed in the 32/43 mm pipework, between the boiler condensate outlet and the drainpipe, outside the property, to avoid flooding during adverse weather conditions.

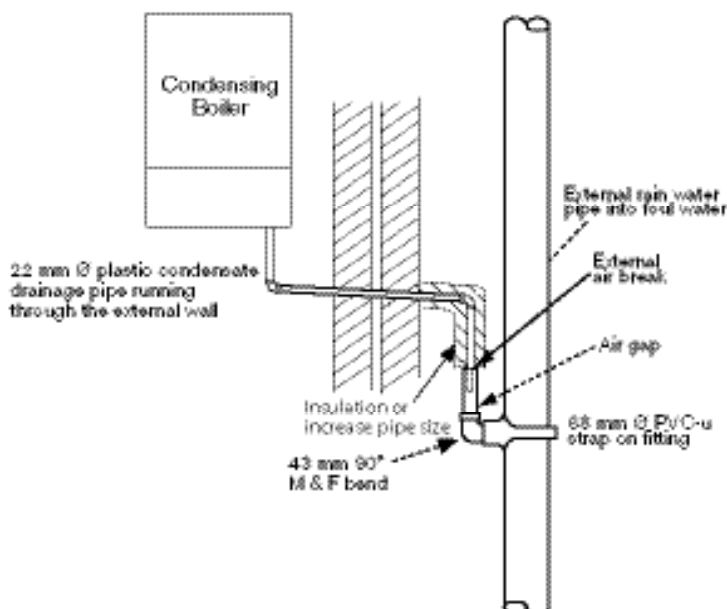
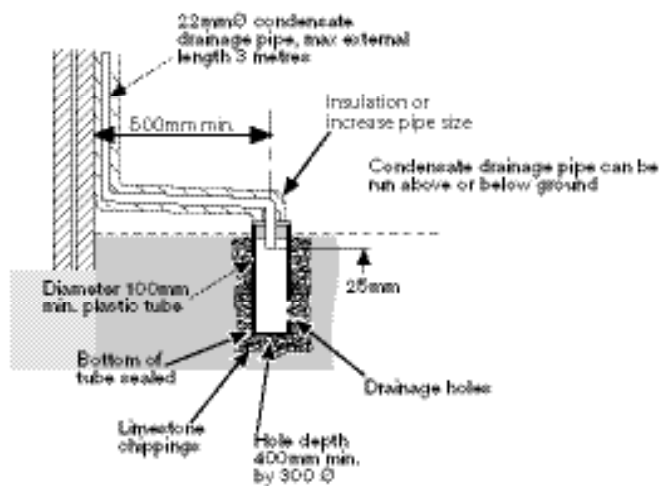
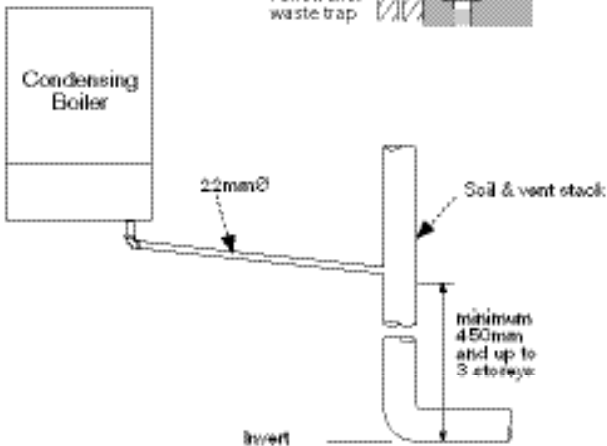
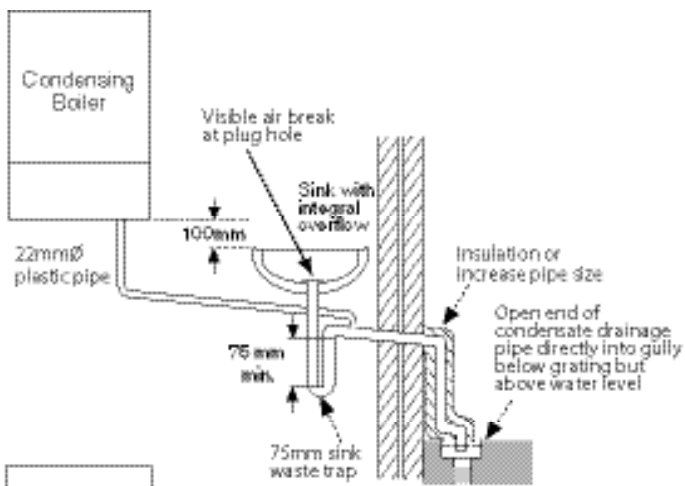

PRESSURE RELIEF PIPEWORK

PRESSURE RELIEF PIPEWORK:

IMPORTANT: The pressure relief valve is a safety device for the boiler and if activated may discharge boiling water steam through the relief valve drain pipe.

Care should be taken when siting the outlet pipe so that it does not cause an obstruction or discharge above a window, entrance or other public access where it could cause a hazard.

- The pressure relief drain pipe (M) from the boiler should be at least 15mm diameter copper pipe and run downwards away from any electrics or other hazard, preferably to an external drain or soakaway.
- Pipe (M) should be finished with a partial bend, near the outlet to face the external wall (as shown) to help prevent freezing.

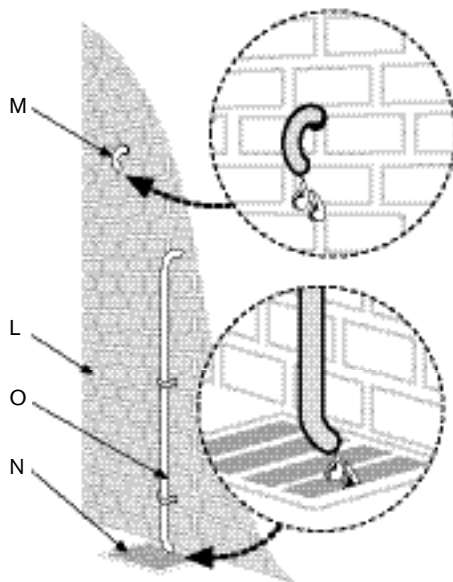

L - Outside wall

O,M - Drain pipe

N - External drain

SERVICING CLEARANCES VENTED COMPARTMENT

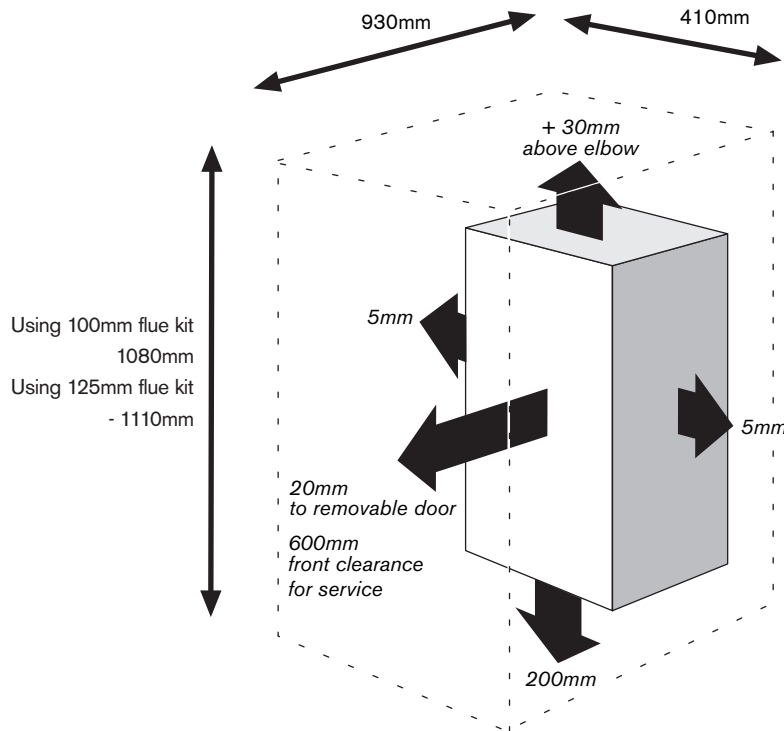

PRE-
INSTALLATION

VENTILATION FREE COMPARTMENTS INSTALLATION CLEARANCES

Ventilation Free Compartment Installation Clearances			
The suggested total unventilated compartment minimum clearances are:			
Side	Above	Below	Front (to removable door)
400mm	170mm approx. (30mm above the elbow)	200mm	100mm

(Note: Top and bottom clearances must not be reduced below these values as they are the minimum required for servicing).

If Side Clearances are Reduced			
If total side clearance is reduced to: **	Then overall height clearances must be increased to (approx): *	OR	Front clearance (to removable door) must be increased to:
350mm	441mm		129mm
300mm	523mm		161mm
250mm	617mm		200mm
200mm	727mm		243mm
150mm	856mm		295mm
100mm	1012mm		358mm
50mm	1202mm		434mm

If Front Clearance is Reduced			
If front clearance (to removable door) is reduced to:	Then overall height clearances must be increased to (approx): *	OR	Total side clearance must be increased to: **
50mm	511mm		505mm
25mm	596mm		569mm

BOILER LOCATION &

CLEARANCES

This boiler is only suitable for installing internally within a property at a suitable location onto a fixed, rigid surface at least the same size as the boiler and capable of supporting the boiler weight.

COMPARTMENTS:

Follow the requirements of BS6798 and BS5440 Part 2 and note:

- Minimum clearances must be maintained
- An access door is required to install, service and maintain the boiler and any ancillary equipment.
- If fitting the boiler into an airing cupboard use a non-combustible perforated material (maximum hole sizes of 13mm) to separate the boiler from the airing space.

BOILER CLEARANCES:

The diagram opposite shows the minimum space required to install and service the boiler.

If a boiler is installed in a compartment with clearances less than shown in the tables opposite, ventilation is required. Refer to tables below for ventilation requirements.

24 & 28 kW		
Vent position	To room or internal space	Direct to outside
High level	Minimum free area 122 cm ²	Minimum free area 61 cm ²
Low level	Minimum free area 122 cm ²	Minimum free area 61 cm ²

BOILER CLEARANCES - UNVENTILATED COMPARTMENTS:

The tables opposite show the options for the minimum space required to install and service the boiler inside an unventilated compartment.

* **NOTE:** These are the combined top & bottom clearances excluding the appliance.

** **NOTE:** These are the combined left & right clearances excluding the appliance.

BOILER LOCATION &

CLEARANCES

BATHROOMS:

A boiler fitted with a non-mechanical timer or with no timer can be installed in zone 2 or outside the shaded area .

A boiler with a mechanical timer, RF mechanical timer or text display with room thermostat must only be installed outside the shaded area.

Additional RCD (Residual Current Device) protection may be required.

Refer to the latest IEE wiring regulations.

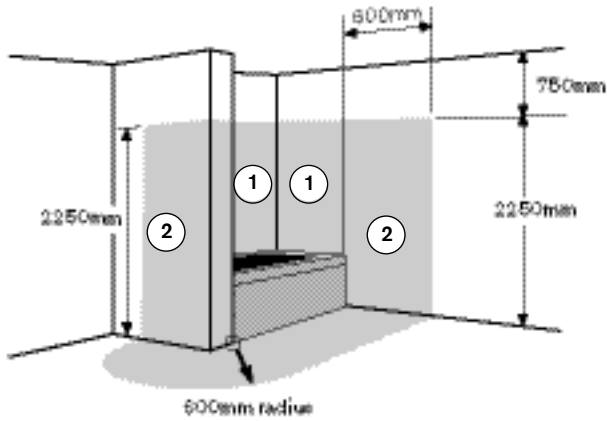
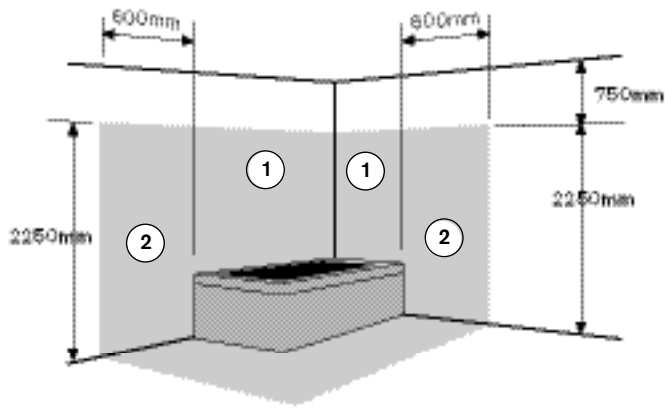

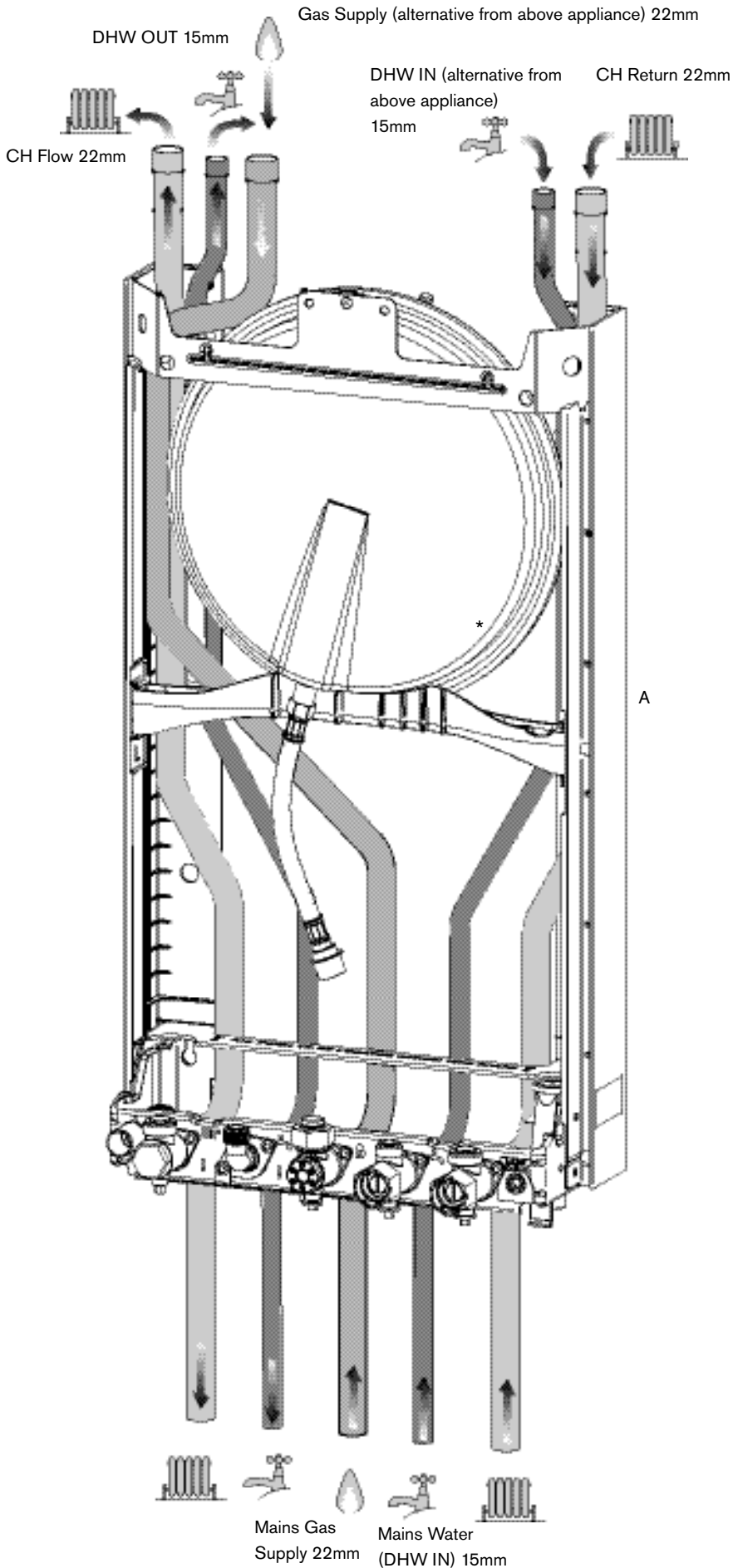

CONNECTIONS:

- Heating System: 22mm compression fittings
- DHW: 15mm compression fittings
- Gas: 22mm compression fittings

Use the fittings supplied in the Lit/Hardware pack.

- If the boiler pipes are to be run behind the appliance ensure that the pipes pass through the slot in the yellow plastic guide (A). This is fitted to the boiler frame.

Further guidance on pipe routing can be found printed on the boiler template (supplied with the boiler).

PRE - INSTALLATION

FLUE OPTIONS

The Greenstar series has the option of two horizontal RSF (60/100 telescopic and 80/125) flue systems and two vertical RSF (60/100 or 80/125) flue systems:

The systems have different maximum flue lengths

This page shows various fluing options with the straight flue lengths required to achieve the maximum flue length. Note that:

- each 90° bend used is equivalent to 2 metres of straight flue
- each 45° bend used is equivalent to 1 metre of straight flue

NOTE: Plume management kits are available for the 60/100 horizontal flue option. Refer to the manual supplied with the Plume management kits for complete installation instructions

Telescopic horizontal flue assembly

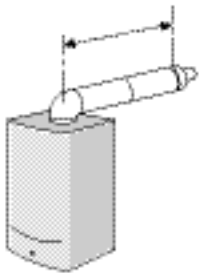

Maximum telescopic flue length		
	100mmØ	125mmØ
24 i jun.	570mm	1,070mm
28 i jun.	570mm	1,070mm

Horizontal flue extension

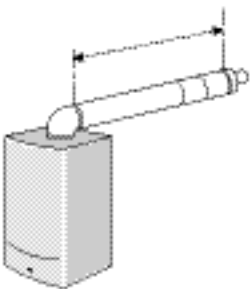

Maximum total flue length		
	100mmØ	125mmØ
24 i jun.	4,600mm	13,000mm
28 i jun.	4,600mm	13,000mm

High level horizontal flue

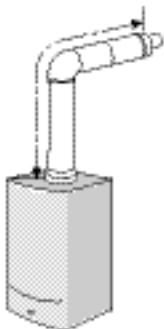

Maximum total flue length		
	100mmØ	125mmØ
24 i jun.	4,600mm	13,000mm
28 i jun.	4,600mm	13,000mm

Horizontal flue with 2x90° bends

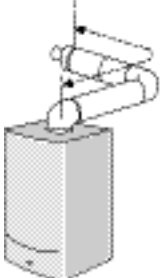

Maximum total flue length		
	100mmØ	125mmØ
24 i jun.	2,600mm	11,000mm
28 i jun.	2,600mm	11,000mm

High level horizontal flue with 2x90° bends

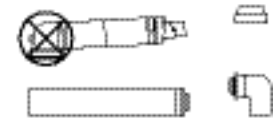

Maximum total flue length		
	100mmØ	125mmØ
24 i jun.	2,600mm	11,000mm
28 i jun.	2,600mm	11,000mm

High level horizontal flue with 3x90° bends

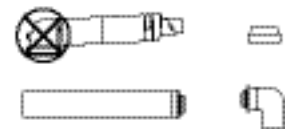

Maximum total flue length		
	100mm,Ø	125mmØ
24 i jun.	N/A	9,000mm
28 i jun.	N/A	9,000mm

PRE -
INSTALLATION

Vertical balanced flue assembly



Maximum total flue length		
	100mmØ	125mmØ
24 i jun.	6,400mm	15,000mm
28 i jun.	6,400mm	15,000mm

Vertical balanced flue system with 2x45° bends

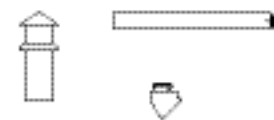

Maximum total flue length		
	100mm,Ø	125mmØ
24 i jun.	4,400mm	13,000mm
28 i jun.	4,400mm	13,000mm

Vertical balanced flue with 2x90° bends

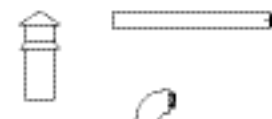

Maximum total flue length		
	100mmØ	125mmØ
24 i jun.	2,400mm	11,000mm
28 i jun.	2,400mm	11,000mm

- The flue must be fitted and terminated in accordance with the recommendations of BS5440 : Part 1.
 - The flue must not cause an obstruction.
 - Discharge and any noise from the flue outlet must not cause a nuisance.
 - Flue gases have a tendency to plume and in certain weather conditions a white plume of condensation will be discharged from the flue outlet. Where this could be a nuisance, for example, near security lighting, an alternate position should be found.
 - The air inlet/outlet duct and the terminal of the boiler must not be closer than 25mm to any combustible material.
- Detailed recommendations on protection of combustible materials are given in BS 5440: Part 1
- A protective terminal guard must be fitted if the terminal is 2m or less above a surface to which people have access. The guard must be spaced equally (minimum 50 mm) around the flue and fixed to the wall with plated screws. See Contact Information (inside front cover).

If plume management is utilised, the clearance from the flue air inlet to any opening can be decreased to 150mm in all cases, as long as the clearance from the flue outlet to any opening and is maintained as shown on this diagram

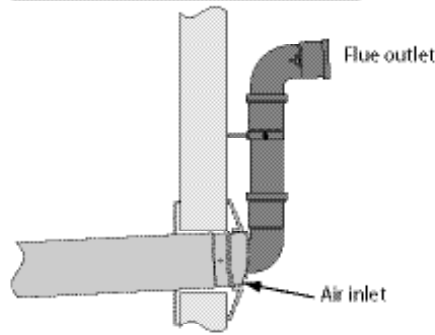

500mm clearance to any vertical structure on a roof, 600mm to another flue or 1500mm to an open flue.

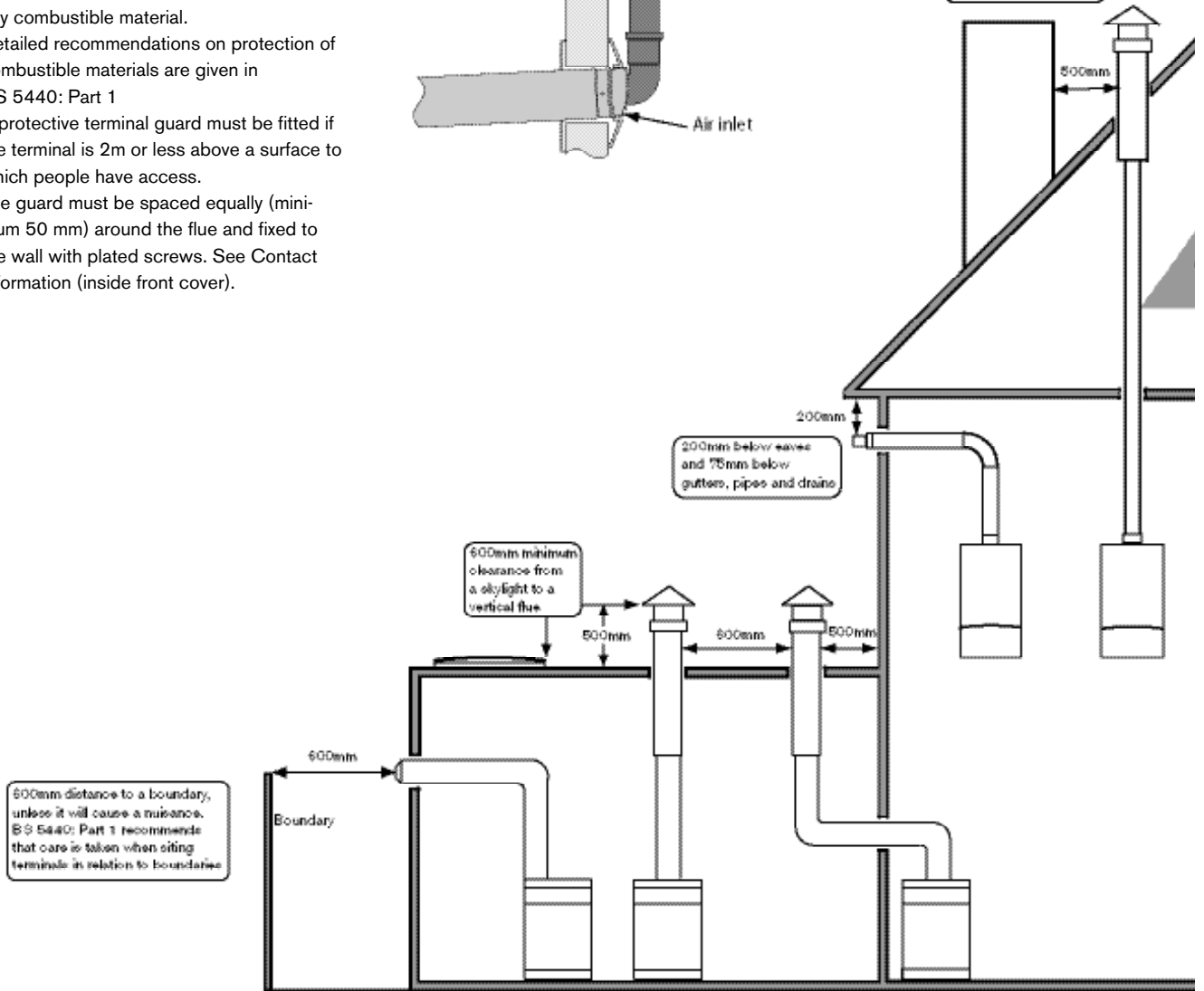

Deduct one metre off the total flue length for every 45° bend used
Deduct two metres off the total flue length for every 90° bend used

The flue turret has a built-in angle of 3° to ensure that the condensate flows back to the boiler for safe disposal via the condensate waste pipe.

All horizontal flue sections must rise by 3° or at least 52mm for each metre away from the boiler to ensure condensate flows back into the boiler.

Vertical flue clearance 500mm to non-combustible building material, and 1,500mm clearance to combustible building material

NOTES:

Plume management kits are available for 100mm horizontally terminated flues. Please refer to the installation instructions supplied with the plume management kits.

If plume redirection is utilised, the clearance from any opening must be increased in the direction of the plume to 1500mm.

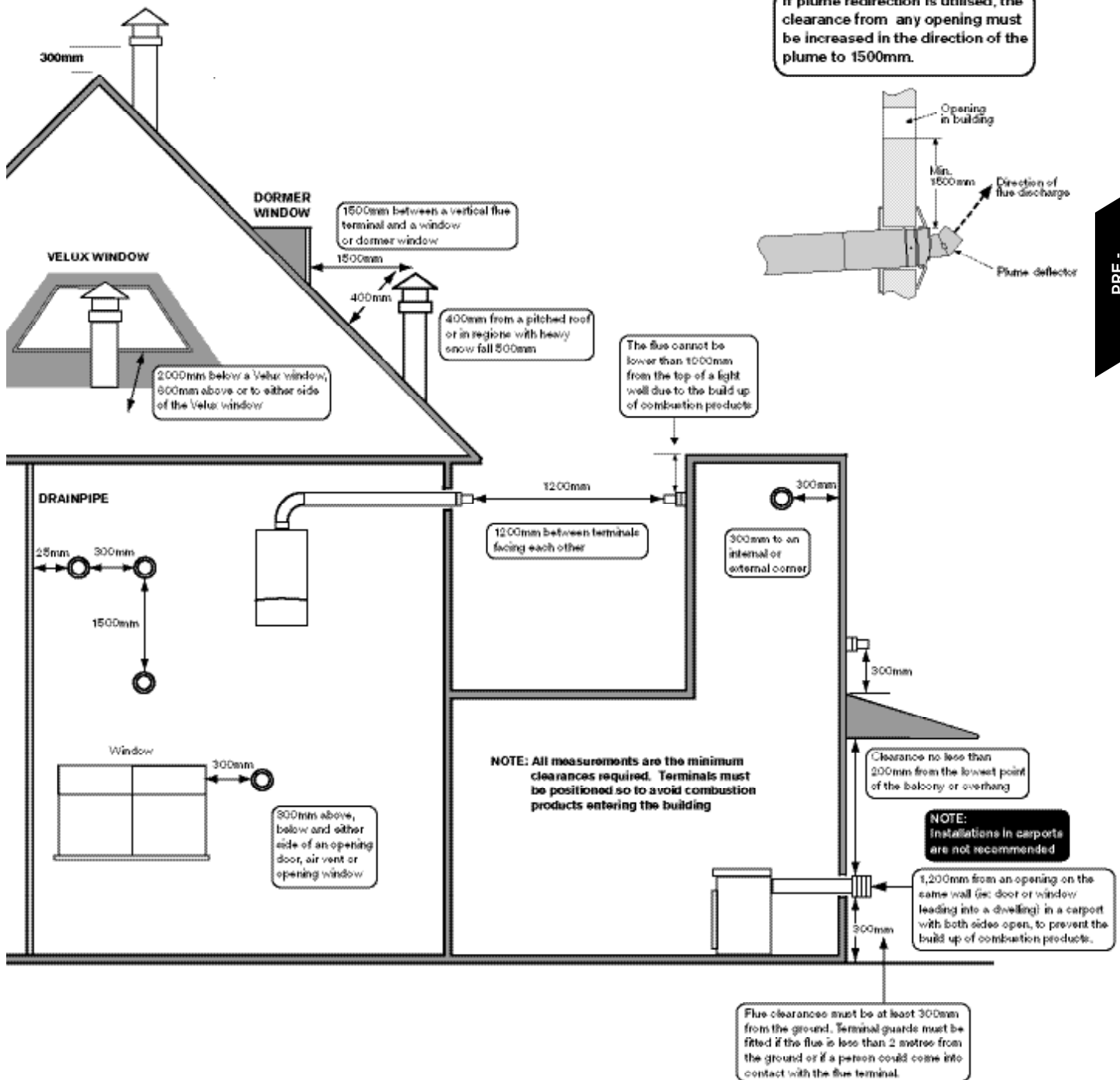

PRE-INSTALLATION

IMPORTANT: All the previous Pre-Installation sections must be read and requirements met before starting boiler or flue installation.

UNPACKING WALL FRAME AND ANCILLARY ITEMS

LIFTING AND CARRYING PRECAUTIONS:

- Lift only a manageable weight, or ask for help.
- When lifting or putting things down, bend the knees, and keep the back straight and feet apart.
- Do not lift and twist at the same time.
- Lift and carry objects close to the body

- A - Straps
- B - Outer carton
- C - Installer pack
- D - Bottom panel
- E - Wall mounting frame
- F - Wall template
- G - Inner packaging
- H - Front fascia
- J - Syphon assembly

IMPORTANT HANDLING INSTRUCTIONS

- It is advised that two people are used to carry the carton from the van to the point of delivery.
- Once the carton has been delivered, the outer carton is removed first. Care should be taken when releasing the straps. If a sharp implement is used make sure the outer carton is not pierced and that the implement is used in such a way so that it may not cause personal injury. All sharp objects must be covered or the blade retracted after use and put away in a safe place. The wall mounting frame, Installer pack, template and bottom panel are now removed. Care should be taken when lifting the boiler from the base and the proper technique for safe lifting of any heavy object should be strictly observed.

Additional requirements for roof space installation:

- The boiler should be first unpacked before ascending ladder to loft space.
- Two sets of steps should be used.
- Two people should share the lifting of the boiler up to the loft hatch, where the boiler is entered into the loft space tilted and slid on its back into the loft.

Once the appliance is removed from its packaging check the contents against the packing list.

Before installing appliance ensure system has been cleaned as explained on page 9.

- ▶ 1. Remove straps (A) and open the top of the boiler packaging.
- ▶ 2. Remove template (F) and wall mounting frame (E) from the packaging.
- ▶ 3. Remove boiler bottom panel (D) and installer pack (C).

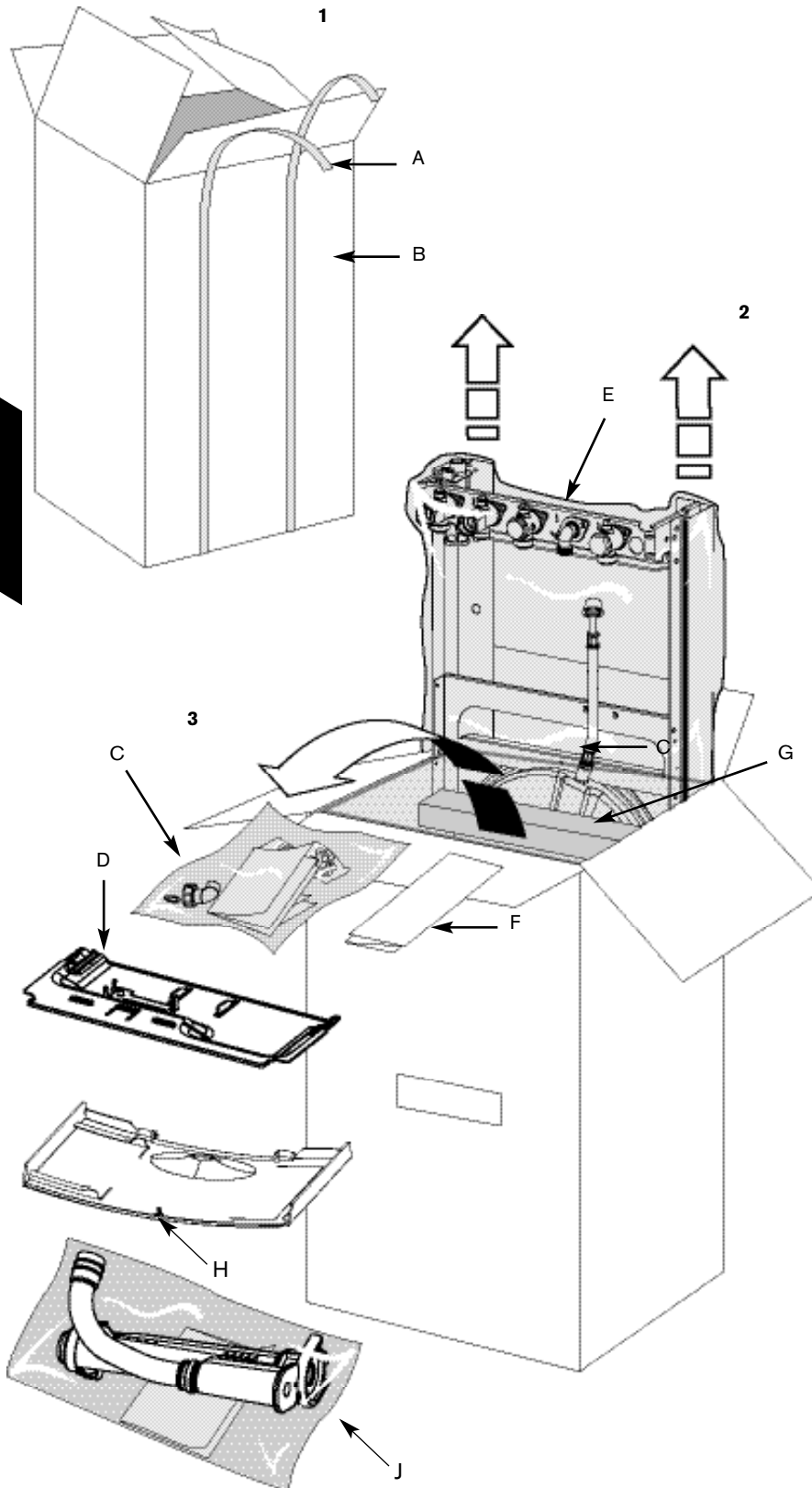

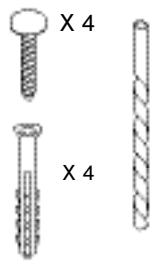

USE APPROPRIATE
FIXINGS FOR
WEIGHT AND
WALL TYPE

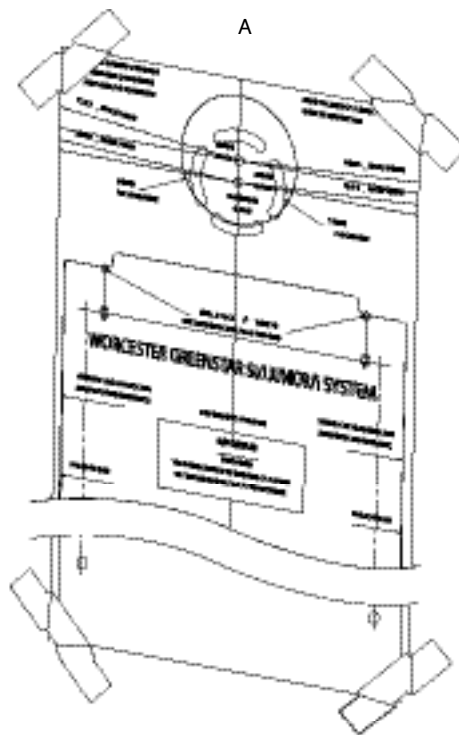

WALL MOUNTING TEMPLATE

FLUE OPENING

CAUTION: Ensure there are no pipes, electric cables, damp proof courses or other hazards before drilling.

SAFETY:

All relevant safety precautions must be undertaken. Protective clothing, footwear, gloves and safety goggles must be worn as appropriate.

FIXING THE MOUNTING FRAME:

- The boiler template shows the relative positions of the flue and the top and bottom fixing of the mounting frame.
- ▶ Fix the template to the wall in the desired position (A).
- ▶ Drill 4 holes for the wall mounting frame through the template (2).

NOTE: The template has been sized to allow for minimum clearances of 5mm sides, 200mm base and 30mm above a Ø100mm flue elbow.

REAR FLUE OUTLET

- The drawing (B) opposite shows the boiler template with the flue centre lines of both the 100mm and 125mm flue systems.
- ▶ Mark centreline of flue to be used (1); the external diameter of the hole can also be marked if required.
- If a Ø100mm diameter flue is to be used, a 125mm diameter hole is required. However, if using the weather sealing collar by pushing it through from inside the property, then a 150mm diameter hole is required to accommodate this.
- The flue turret of the 100mm flue has an in-built 3° angle. If extensions are to be added then the complete flue must rise at an angle of 3°.
- The 125mm Ø flue system will require the flue to rise at an angle of 3°.
- ▶ Drill hole using a core drill or similar.

SIDE OUTLET:

- ▶ Mark from the centre line of the wall template to the wall which the flue will pass through (3).
- ▶ Allow for a rise of 52mm per metre length of flue, to give a 3° angle.
- ▶ Clear any debris from the site.
- A pre-filling kit 7 716 192 282 is available for installations where the boiler will not be fitted immediately to the heating system. This allows the heating system and mains water connections to be filled and checked prior to boiler installation. This kit can be used in conjunction with the optional filling loop 7 716 192 281 (not supplied with the boiler).

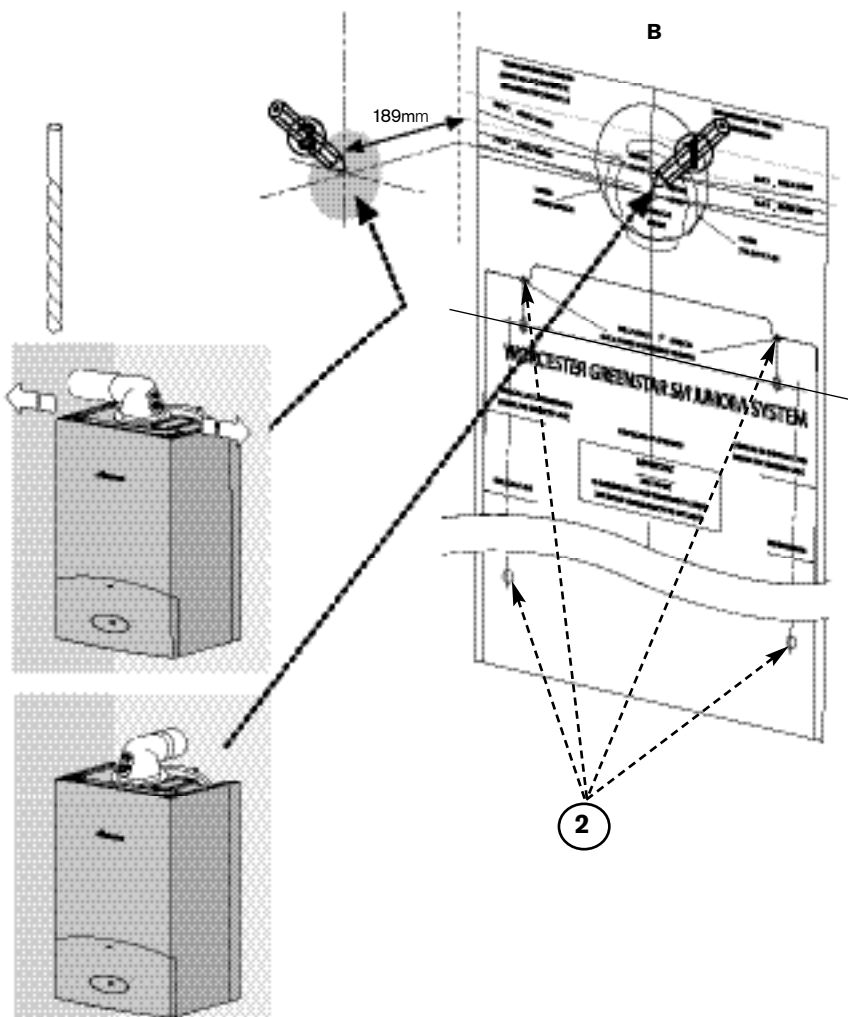

UNPACKING THE APPLIANCE

UNPACKING THE APPLIANCE

- A - Outer carton
- B - Inner sleeve (unwraps from front)
- C - Packaging base
- D - Protective wrapping
- E - Appliance outer case

- ▶ **4.** Remove outer carton (A) and place safely away from the working area.
- ▶ **5.** With the outer packaging removed and the inner sleeve (B) still in place gently lay the boiler on its back.
- ▶ **6.** The boiler will lie at an angle to the floor to allow the boiler outer casing (E) to be removed. The inner sleeve (B) opens as shown. Remove the protective wrapping (D) and undo the four screws, two at the bottom of the boiler (H) and two at the top (H) (see diagrams 6.1 and 6.2). Remove any packaging within the boiler and the packaging base (C).

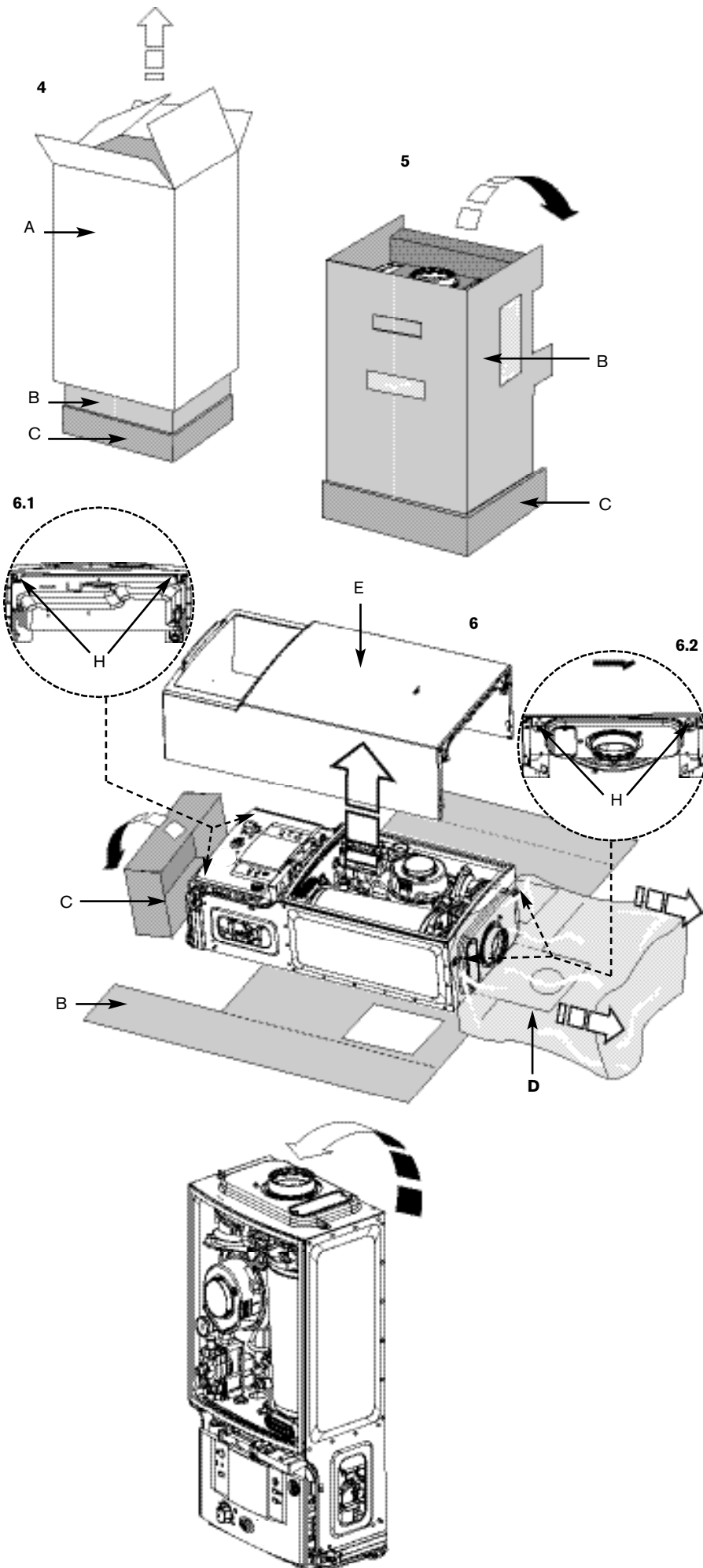

INSTALLATION

CAUTION: Caps fitted to pipes must be removed before hanging the boiler.

BOILER CONNECTIONS

CAUTION: ISOLATE THE MAINS GAS SUPPLY BEFORE STARTING ANY WORK AND OBSERVE ALL RELEVANT SAFETY PRECAUTIONS.

GAS AND WATER CONNECTIONS:

- ▶ Remove template and secure the wall mounting frame to the wall with the fixings supplied.
 - ▶ System pipes may be run vertically upwards behind the boiler or below it. See Plumbing Manifold Section on page 16.
- A - CH flow (22mm), B - CH return (22mm),
C - Gas inlet (22mm), D - Mains water inlet (15mm), E - DHW outlet (15mm)

- ▶ 1. If using the optional filling loop 7 716 192 281 (not supplied with the boiler) fit it before hanging the boiler on the wall frame.
- ▶ 1A. Fit sealing washers to service valves before hanging boiler.

NOTE: The bonded washer supplied is for the Gas connection only.

IMPORTANT:

Before hanging the boiler onto the wall mounting frame ensure that the pressure relief valve connection is in the DOWN position. This is located on the right hand side of the wall frame at the rear.

- ▶ 2. Pull the extended tab/lever forward and down until there is no further travel.

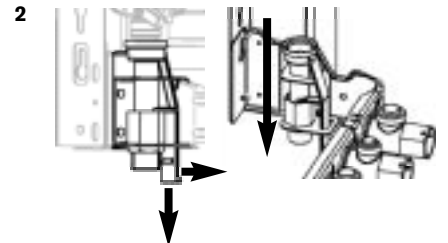

- ▶ 3. Hang the boiler on to the wall mounting frame by the two brackets positioned left and right at the top rear of the appliance. Do not lift the appliance by the air gas manifold. There are two handling holes incorporated into the inner casing left and right in the lower section of the appliance.

IMPORTANT:

The pressure relief connector must be repositioned after the boiler has been correctly mounted to the wall mounting frame.

- ▶ 4. Push the lever on the pressure relief connector UP until the stop on the inside of the handle is over the shoulder of the metal bracket to secure in place.

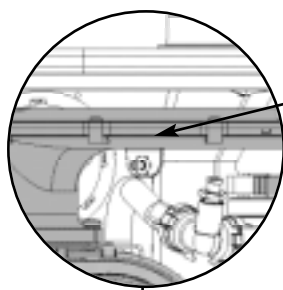
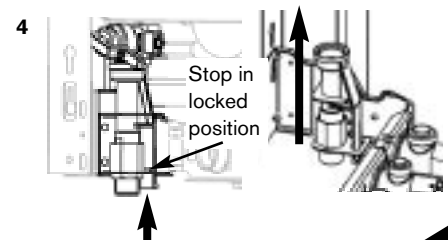

Do not lift by the air gas manifold.

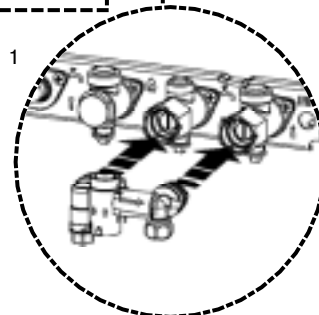
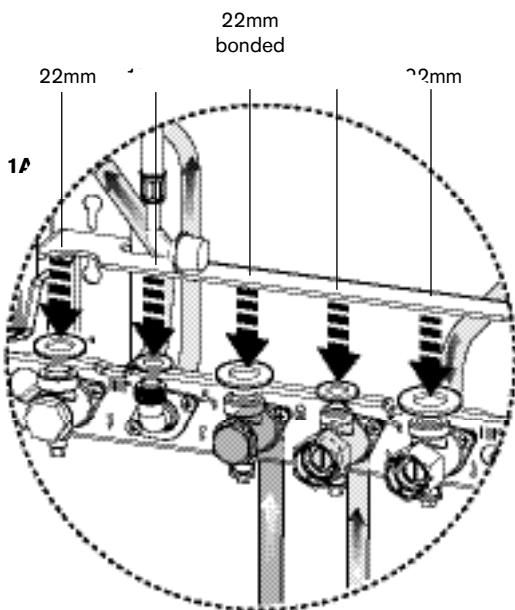
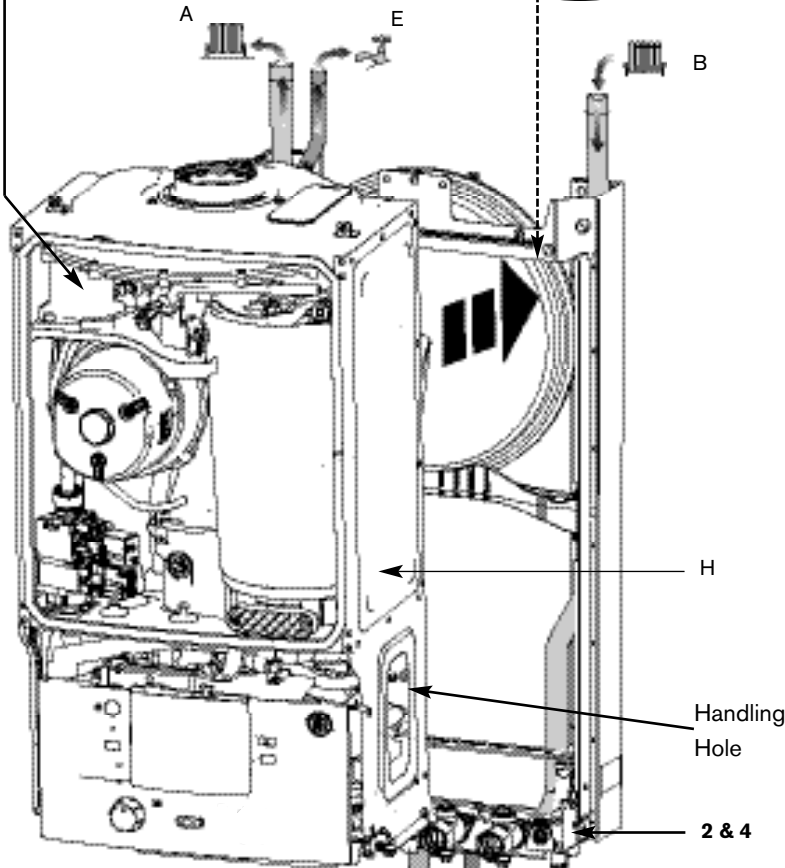
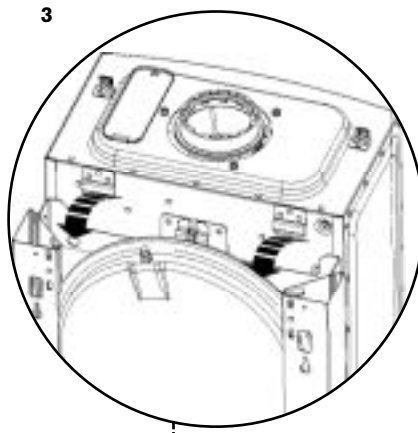

INSTALLATION

BOILER CONNECTIONS

CAUTION: ISOLATE THE MAINS GAS SUPPLY BEFORE STARTING ANY WORK AND OBSERVE ALL RELEVANT SAFETY PRECAUTIONS.

GAS AND WATER CONNECTIONS:

- A - CH flow (22mm),
- B - CH return (22mm),
- C - Gas inlet (22mm),
- D - Mains water inlet (15mm),
- E - DHW outlet (15mm)

- ▶ **5.** Lower the control panel into the service position by removing the screw (F) from the retaining bracket.
- ▶ **6.** Make connections to the heating system.
- ▶ Connect the gas supply to the boiler gas cock 22mm compression.
- ▶ Connect mains water in and DHW out.
- ▶ **7.** Connect the expansion vessel flexible pipe to the hydraulic manifold situated left of the pump. It is necessary to remove and discard the orange plastic blanking plug (G) from the pressure vessel connection at the hydraulic manifold before securing the expansion vessel flexible pipe (H) in place with the wire retaining clip (I).
- ▶ **8.** Connect the pressure relief drain pipe to 15mm compression joint (J) using the compression nut and olive supplied in the hardware literature pack.

INSTALLATION

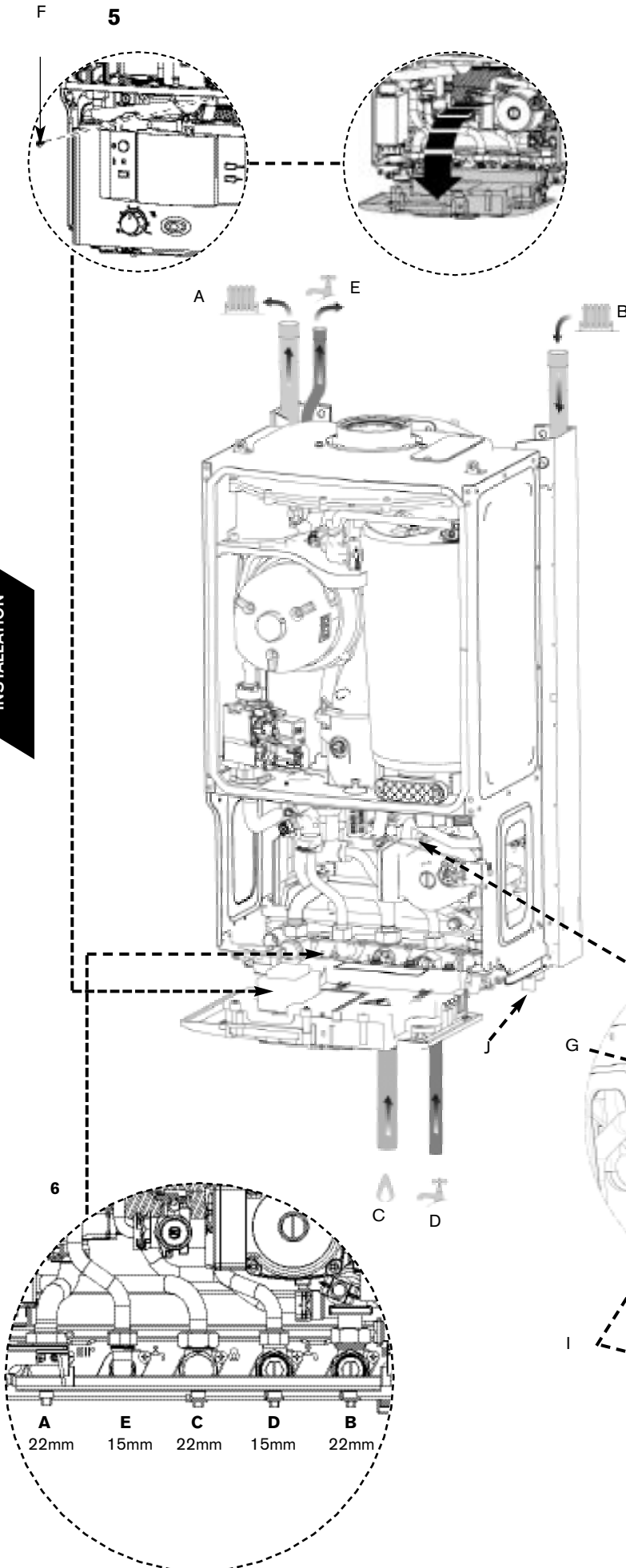

FLUE INSTALLATION

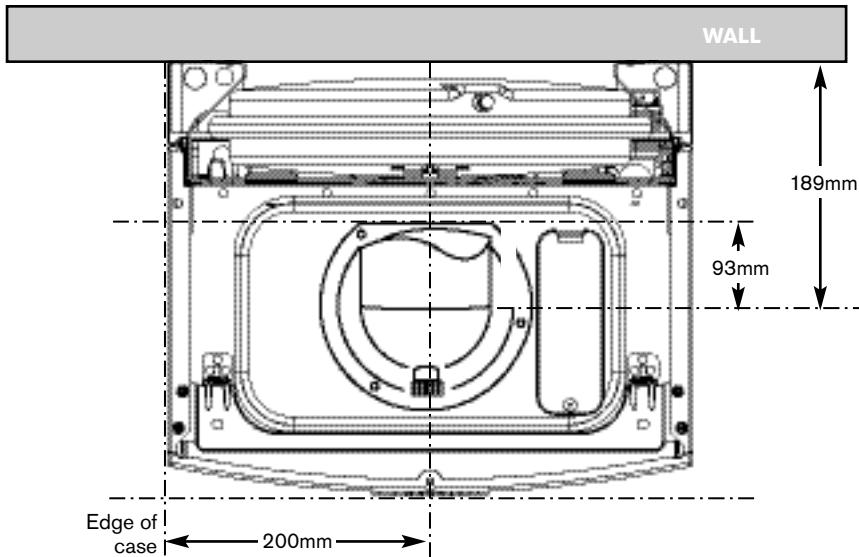

HORIZONTAL FLUE (60/100mm diameter)

For vertical flues and 80/125mm horizontal flues, please refer to separate instructions supplied with the flue kit.

NOTE: to ease assembly of flue components, apply silicone lubricant to sealing surfaces.

Basic instructions for the 60/100mm diameter flue are shown below.

MEASURING THE FLUE (Standard Flue):

- ▶ Measure from the outside wall to the centre line of the flue turret.
- ▶ Subtract 93mm from the length L to give the correct dimension to the flue elbow connection.
- ▶ If the length L falls within the telescopic range of 350 to 570mm, then no cutting will be required.
- ▶ If the required length is less than 350mm the standard telescopic flue can be modified, refer to section 3.
- ▶ If the required length is greater than 570mm, then flue extensions will have to be used. Refer to the 60/100 Horizontal Flue Instruction manual provided in the flue extension kit.

Adjusting the standard terminal length:

- 2 Extend tube (A) by withdrawing from tube (B) to achieve the flue length required, between 350- 570mm.

NOTE: Ensure that the TOP label of both sections are aligned before securing the two parts at the required length.

The flue terminal MUST be fitted with the 'TOP' label uppermost to allow the correct fit and use of the plume management system. Secure with screw provided and seal joint with the aluminium tape supplied.

Reducing the standard terminal length:

- 3 Remove securing screws (C) to detach the terminal assembly from the turret. Slide terminal section (B) from the terminal assembly and discard. To use terminal (A) without cutting remove the location lug (D) on the inner flue tube (E) and remove any burrs.
- To reduce the terminal length further:
 - 4 Mark the length required for the terminal (F) as shown (min. 130mm) and cut square, taking care not to damage the tubes. Remove any burrs and chamfer the outer edge of the tubes to assist ease of connection and prevent seal damage.

NOTE: The aluminium tape is not required when reducing the terminal.

- ▶ After cutting, the end must be square and free from burrs to prevent damage to the flue seals.

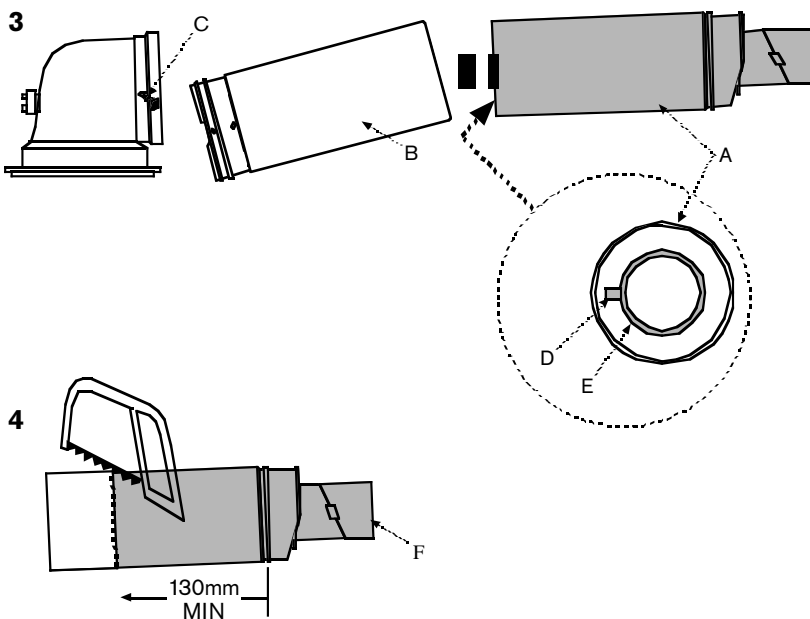
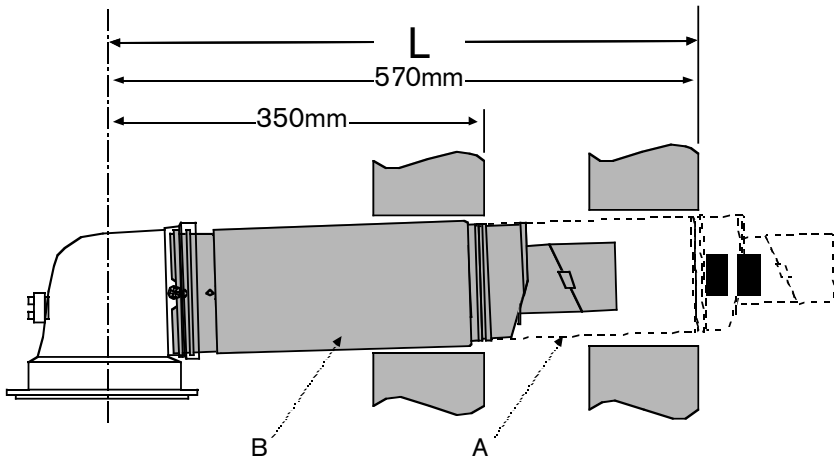

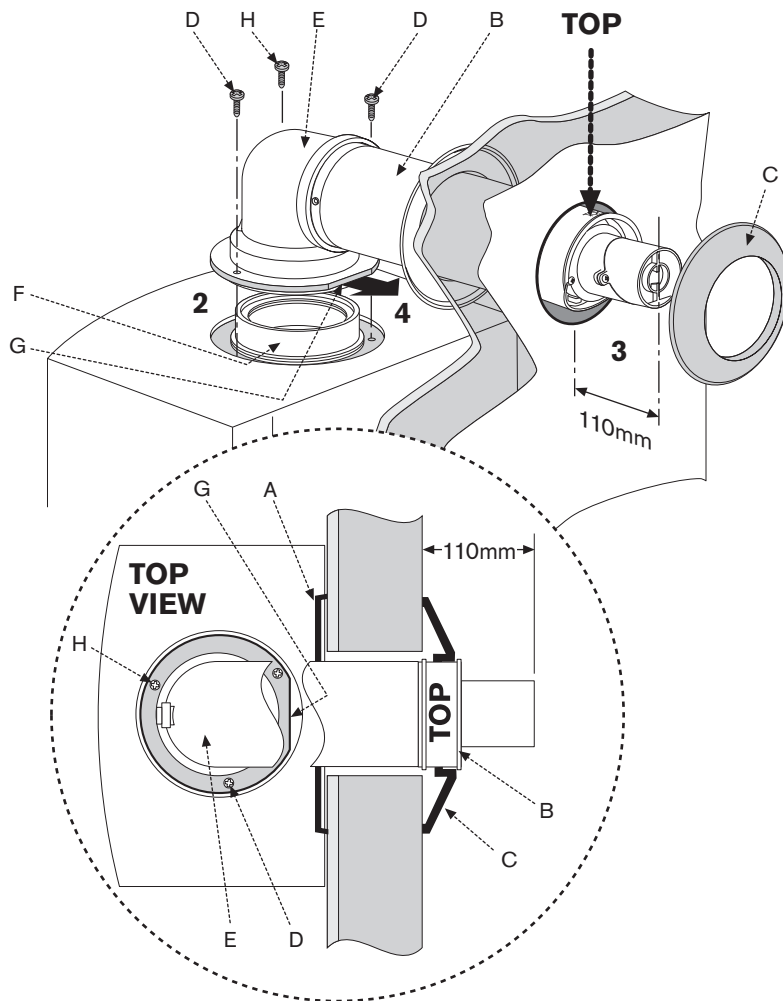
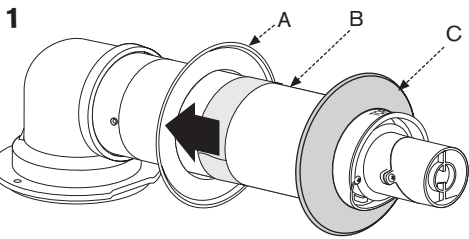

INSTALLATION

FLUE INSTALLATION

Installing the standard flue:

- 1 Set the flue length to the distance required, secure with screw and seal joint with the aluminium tape supplied. Slide the inner wall seal (A) onto the terminal (B) as shown.
If fitting from inside the building; slide the outer wall seal (C) onto the terminal (B) as shown.
- 2 Remove the three screws (D, H) around the flue outlet (F) on the boiler. Check the boiler flue seal is correctly seated. Apply silicone grease to the boiler flue seal.
- 3 Position terminal (B) through the flue opening in the wall to the outside of the building by the distance shown.
The flue terminal **MUST** be fitted with the 'TOP' label uppermost to allow the correct fit and use of the plume management system.
- 4 Align the flue turret (E) to the boiler flue outlet (F) with flat (G) facing to the rear of the boiler. Push the flue turret (E) straight down into the boiler flue outlet (F).
For ease of assembly, locate screw (H) first and then fit screws (D) to secure flue turret (E).
If fitting from the outside of the building; slide the outer wall seal (C) onto the terminal (B) as shown.

NOTE:

For more information refer to the 60/100 Horizontal Flue kit Instruction Manual

FLUE TERMINAL PLUME RE-DIRECTION:

The flue discharge can be redirected allowing some plume re-direction control, alternatively, a complete plume management system can be fitted to the flue terminal.

Redirecting the flue discharge:

- 1 Remove screws (A) and rotate the terminal end (B) through 180°.
DO NOT rotate the complete flue terminal assembly.
- 2 Refit the terminal end (B) and secure with screws (A).
- 3 Loosen screws (C) and rotate the entire outlet assembly to redirect the plume. Retighten screws (C) to secure in the required position.

NOTE: The flue terminal outlet has built-in stops to limit rotation for horizontal fluing to allow condensate to run back into the boiler for safe disposal. Do not attempt to force beyond the limit stops.

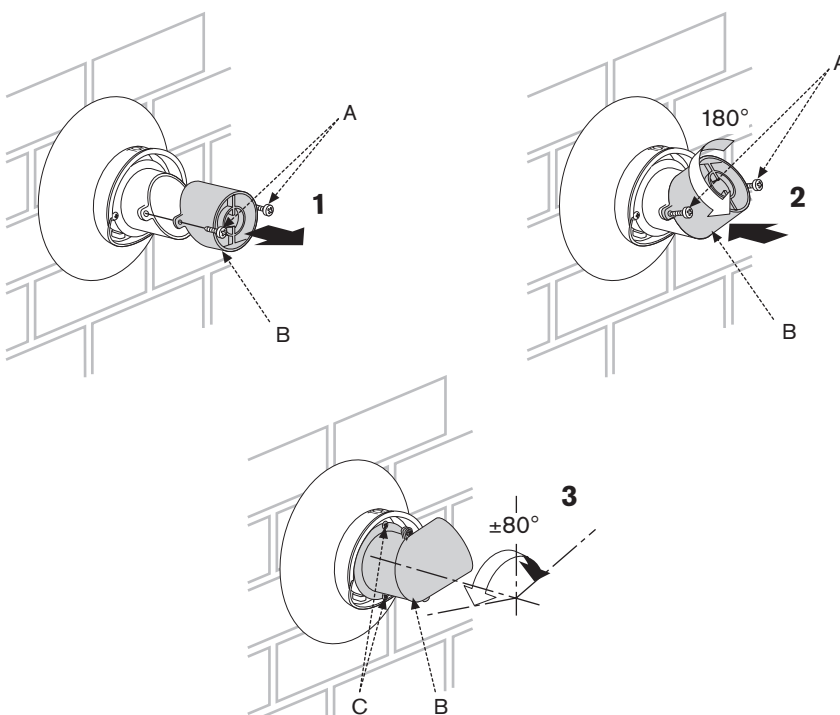

FLUE INSTALLATION

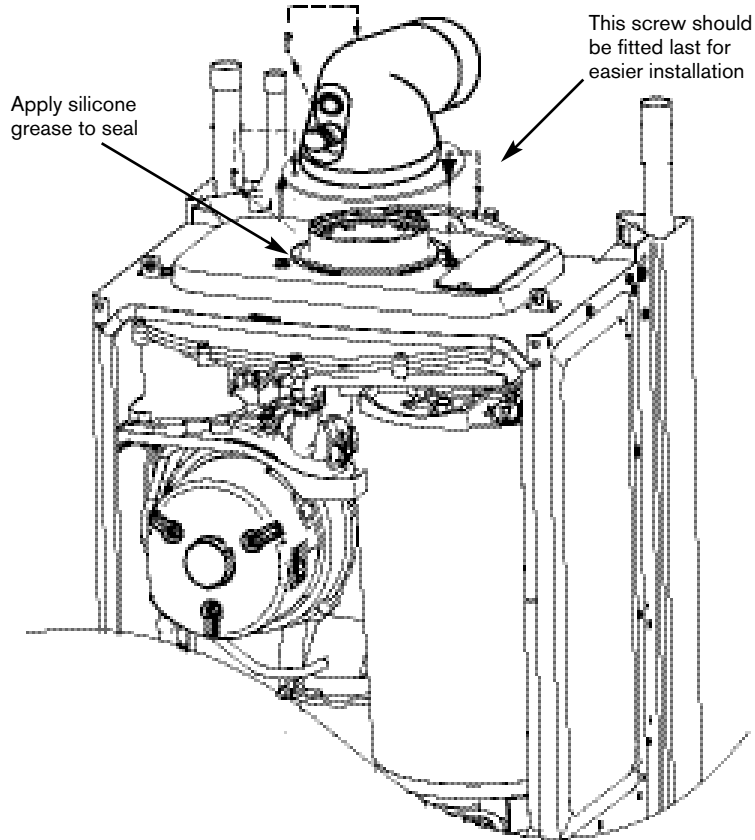

4 Assemble elbow to boiler using the three screws (see below).

Note: Screws are in boiler not in flue kit.

FITTING THE ELBOW:

- Flue elbow should push directly down and not be twisted into correct position.
 - ▶ Remove the 3 inner flue tube retaining screws. The inner tube will be held in place in the appliance.
 - ▶ Fit turret onto appliance and retain with the three removed screws.
- NOTE: The clamping plate flat should be at the rear of the appliance.

ADDITIONAL NOTES AND REMINDERS:

- Ensure that all cut lengths are square and free from burrs.
- The flue, when assembled, is fully sealed and components are pushed home.
- The flue is set at an angle of 3° or 52mm per 1m length.

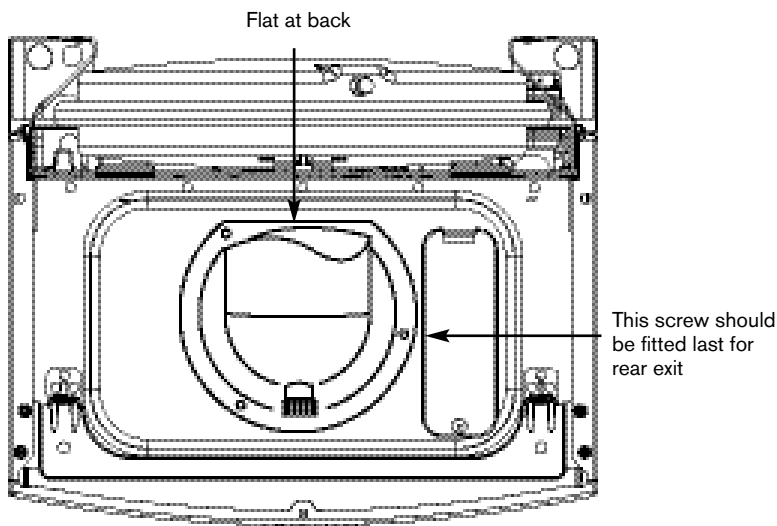

CONDENSATE CONNECTION

CONDENSATE CONNECTION:

Never terminate or discharge into any open source, including; sink, bath, shower, bidet, toilet etc.

Note: Any external condensate pipework should be protected with weather resistant insulation to help prevent freezing.

- Ensure that the condensate drain is 22mm diameter plastic pipe. It must fall at least 50mm per metre towards the outlet.

Note: Do not use lubricants or sealing compounds.

- 1 Remove the sump blanking cap from the sump.
- 2 Fill syphon with 200 to 250 millilitres of water.

Note: Pull the fan lead and ignition cable out of the way when fitting the syphon to ensure that they are not trapped by the syphon assembly or discharge hose.

3 To fit the syphon assembly:

Note: Do not use solvents, adhesive or lubricant when pushing the pipe onto the rubber connector.

- Slide the assembly onto the sump connection.
- Push the syphon onto the sump assembly, until the lug on the sump is fully engaged with the slot on the back of the syphon assembly.

- 4 Push the discharge hose, onto the wall frame connector, until fully engaged.

Maintenance

There is no need to remove the Syphon Assembly for cleaning.

To drain debris from the syphon, during the annual service, release the clips and remove the drainage cap from the bottom of the syphon.

Empty the debris and condensate from the syphon into a suitable container.

Re-fit the drainage cap to bottom of the syphon.

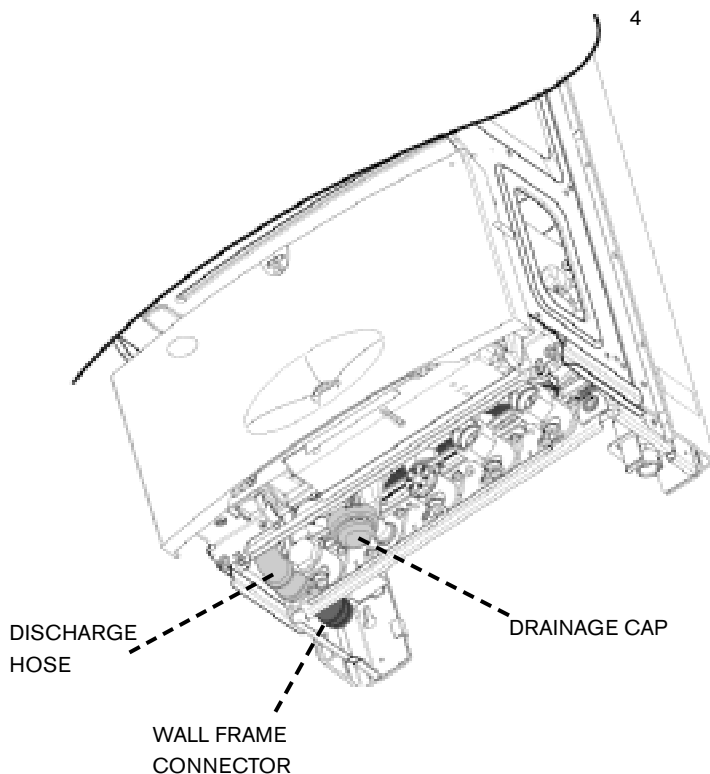
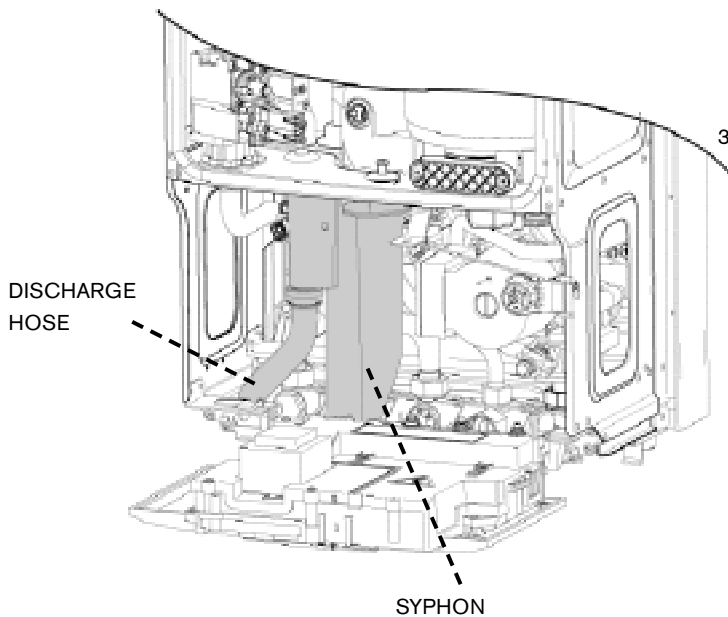
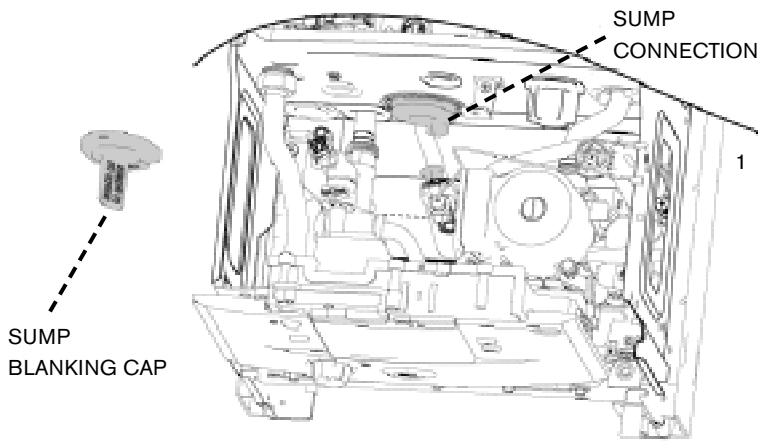

ELECTRICS

CAUTION: ISOLATE THE MAINS ELECTRICITY SUPPLY BEFORE STARTING ANY WORK AND OBSERVE ALL RELEVANT SAFETY PRECAUTIONS

The boiler is pre-wired with a two metre mains supply cable

The mains supply to the boiler must be either:

- from a fused double pole isolator situated next to the appliance. The isolator must have a minimum of 3mm contact separation in both poles.

or

- from a plug and non-switched socket

Use a 3A fuse in both situations.

When stripping wires always ensure copper strands do not fall into the control box.

Access to electrical connections:

Remove boiler casing to access control panel.

- 1 Unscrew screw (A) and lower the control box into the horizontal position.
- 2 Unscrew the three screws (B) in the control panel and pull off the connections cover.
- 3 Pass the 230 V mains power cable, from the control box, through the grommet at the right hand side of the pre-plumbing manifold and route to the mains isolator next to the boiler.
- 4 230V room stat/clock (ST10):
The diagram shows the option of roomstat with programmer or roomstat only.
 - ▶ Remove link.
 - ▶ Connect room stat LIVE supply to terminal (Ls)
 - ▶ Connect room stat LIVE return to terminal (LR)
 - NOTE:** This is sometimes referred to as 'call for heat' or 'heating load'.
 - ▶ Connect room stat NEUTRAL to terminal (Ns)
 - NOTE:** Some devices do not require this.
- 5 Optional external frost stat connection (ST6):
 - ▶ Connect froststat cables to terminals (FS) and (FR). These are not polarity sensitive.
- 6 Refit panels.

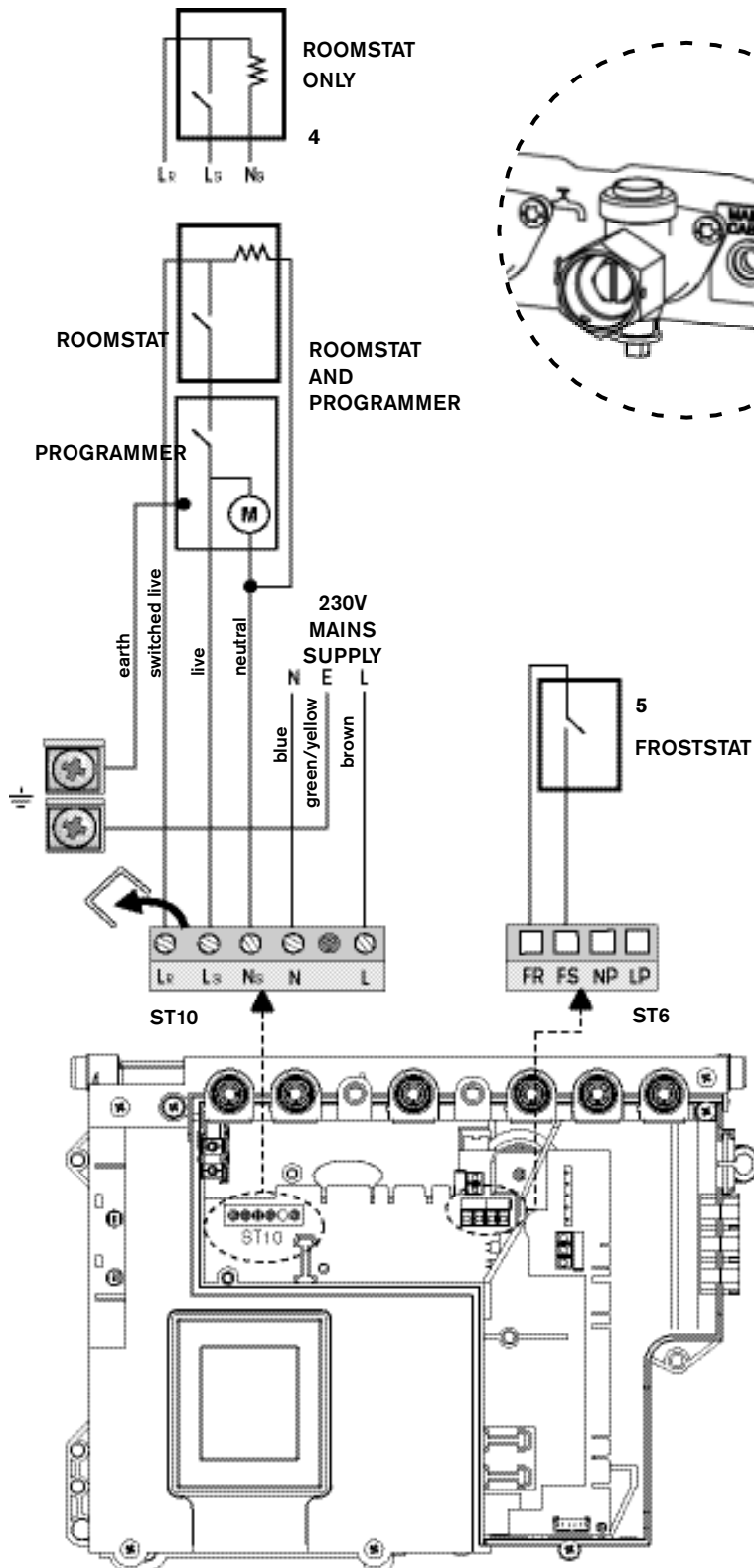
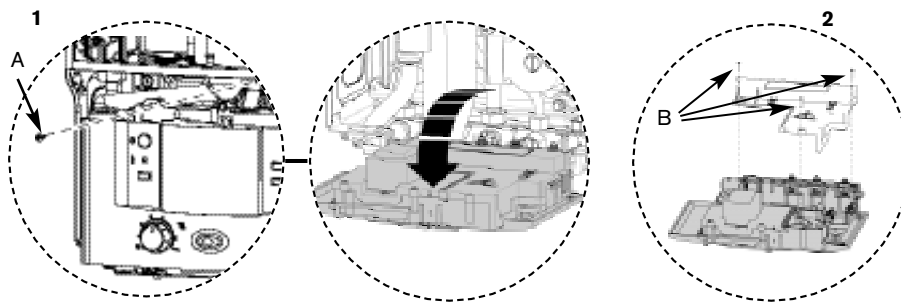

POSITION OF WIRED
COMPONENTS

INSTALLATION

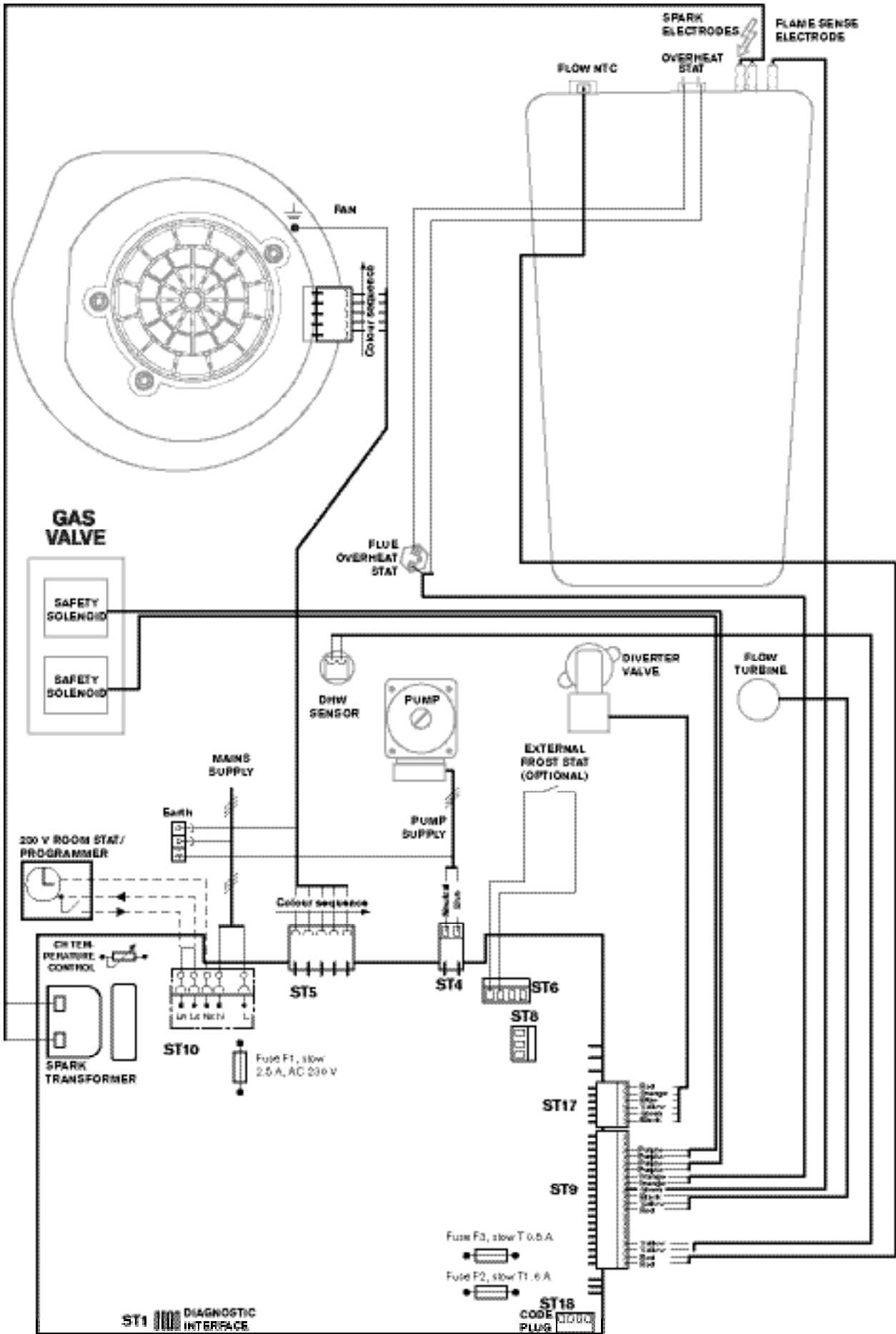

PRE-COMMISSIONING

CHECKS

CAUTION: ISOLATE THE MAINS SUPPLIES BEFORE STARTING ANY WORK AND OBSERVE ALL RELEVANT SAFETY PRECAUTIONS

- 1 Check that the service and water pipes are connected to the correct position on the manifold.
 - A - CH Flow (22mm)
 - B - CH Return (22mm)
 - C - Gas inlet (22mm)
 - D - DHW (15mm)
 - E - Water in (15mm)
- 2 Check the gas type specified on the identification plate (F) matches that of the gas supply. Turn on the main gas supply, check the gas pipework, connections and rectify any leaks.
- 3 Check that the condensate pipe has been connected to the syphon.
- 4 Check pressure relief drain pipe (J) is correctly fitted and securely tightened.

IMPORTANT: If the boiler is not to be commissioned immediately then: after successfully completing all of the checks and any rectification work, close the gas and water valves, shut off the gas supply and electrically isolate the boiler and label appropriately.

COMMISSIONING

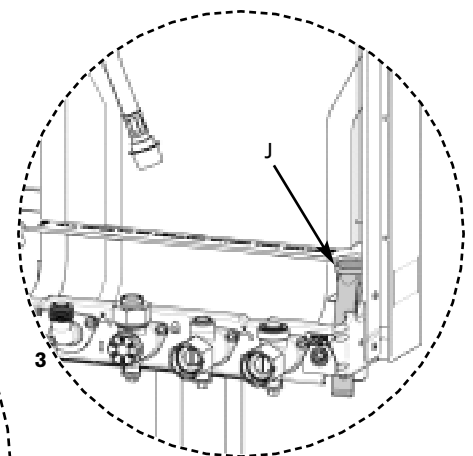
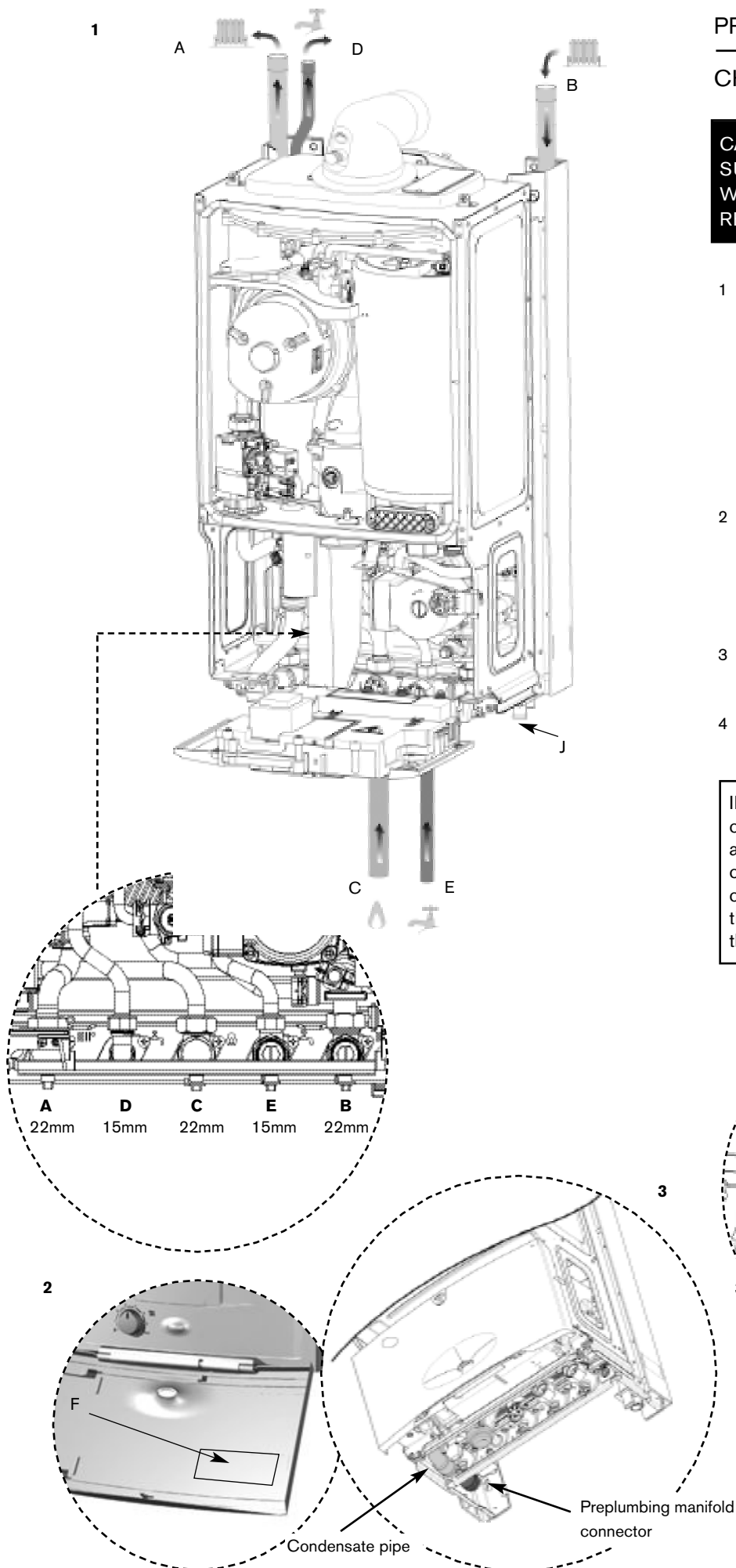

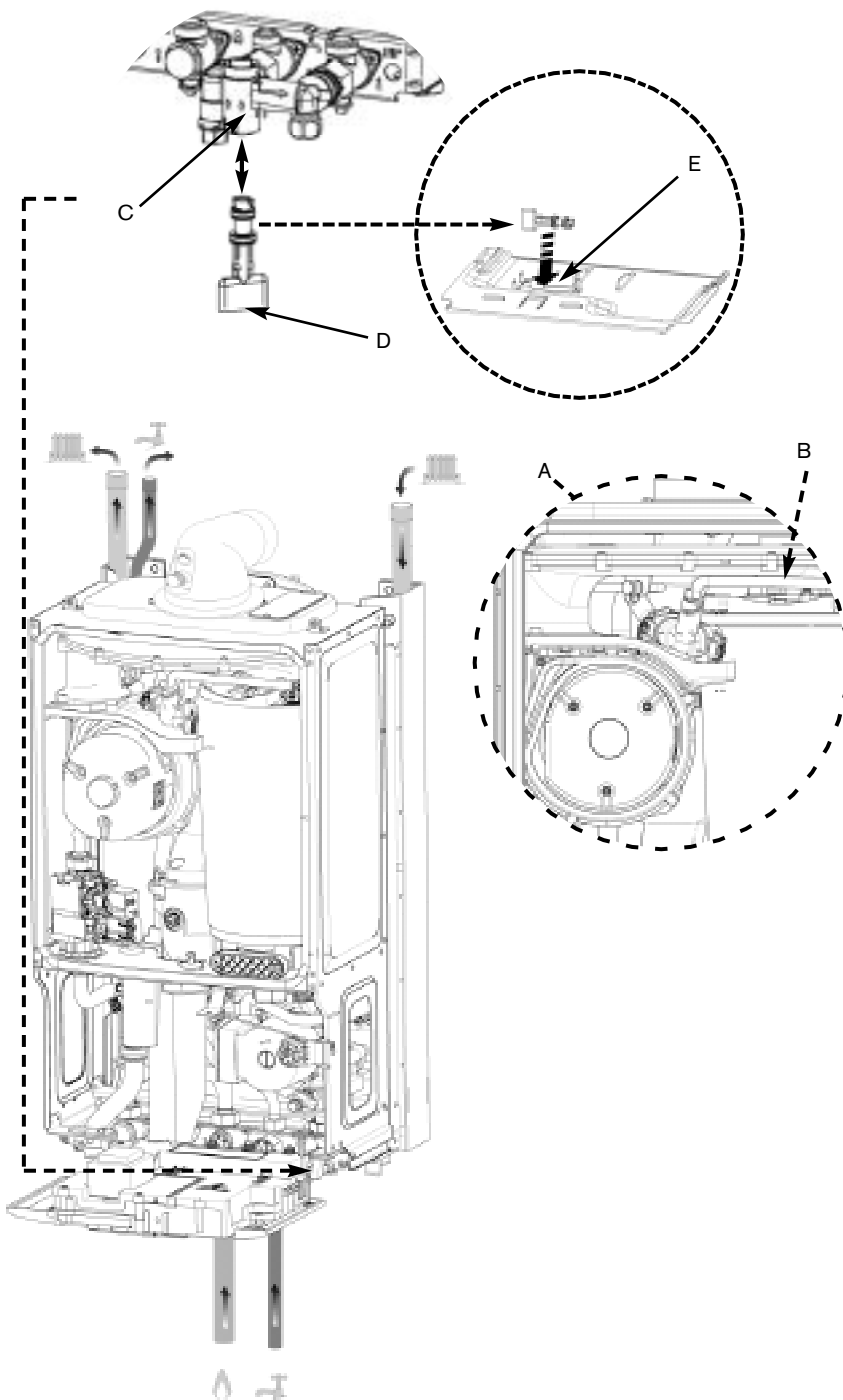

- 1 Turn on the water main and open the system valves.
- 2 Open all radiator valves.
- 3 Fill the system via a WRAS approved filling loop to 1 bar then turn the valve anti-clockwise to close.
- 4 Vent (A) any air from the boiler heat exchanger using a suitable container to collect any water. Ensure tube outlet (B) is directed away from the fan or any other electrical component to prevent any water damage. Also place a suitable cover over the fan to prevent any spillage of water on to electrical connections. **Ensure the cover is removed after venting.**
- 5 Vent all radiators, retighten when completed and check the system and correct any leaks.
 - The boiler integral expansion vessel is pre-charged to 0.75 bar (equal to a static head of 7.5m (22ft). A Schraeder type valve is fitted to the expansion vessel to allow for pressure adjustment if required.
 - If an extra expansion vessel is fitted to the central heating return, adjust this to the **same pressure** as the appliance internal expansion vessel, refer to separate instructions with the extra expansion vessel.
- 6 Briefly open the pressure relief valve to test its operation.
- 7 If required increase system pressure back to 1 bar.
- 8 Rotate the adjustable pointer on the pressure gauge to record the set system pressure.
- 9 Isolate and remove filling loop connection to system or if using the optional integral filling connection (C) (**not supplied with the boiler**) remove key (D) and place in its storage position (E) on the bottom cover of the boiler.
 - A pre-filling kit 7 716 192 282 is available for installations where the boiler will not be fitted immediately to the heating system. This allows the heating system and mains water connections to be filled and checked prior to boiler installation. This kit can be used in conjunction with the optional filling loop 7 716 192 281 (not supplied with the boiler).

STARTING THE APPLIANCE

IMPORTANT: Never run the appliance when the appliance/system is empty or partially filled.

Switching the appliance on/off:

- 1 ▶ Turn on mains power supply
 - ▶ Turn on any external controls
 - Set the thermostatic radiator controls to maximum temperature
 - Set the clock/programmer to continuously ON and the room thermostat to maximum temperature
- 2
 - A - On/off button
 - B - On/off and fault indicator (BLUE)
 - C - Central heating temperature control
 - D - Burner indicator (GREEN)
 - E - Reset button
 - F - Service button
 - G - ECO button
 - H - System pressure gauge
 - I - Cover or optional programmer
 - ▶ Press power button (A) and the power on indicator (B) illuminates BLUE.
- 3 ▶ Turn the boiler thermostat control (C) to maximum. The burner on indicator (D) illuminates GREEN when the burner has lit.
- 4 ▶ If the boiler fails to light the BLUE power indicator (B) and reset button (E) will flash alternately.
To reset press and hold the reset button (E) for 2 seconds. The boiler will be reset.

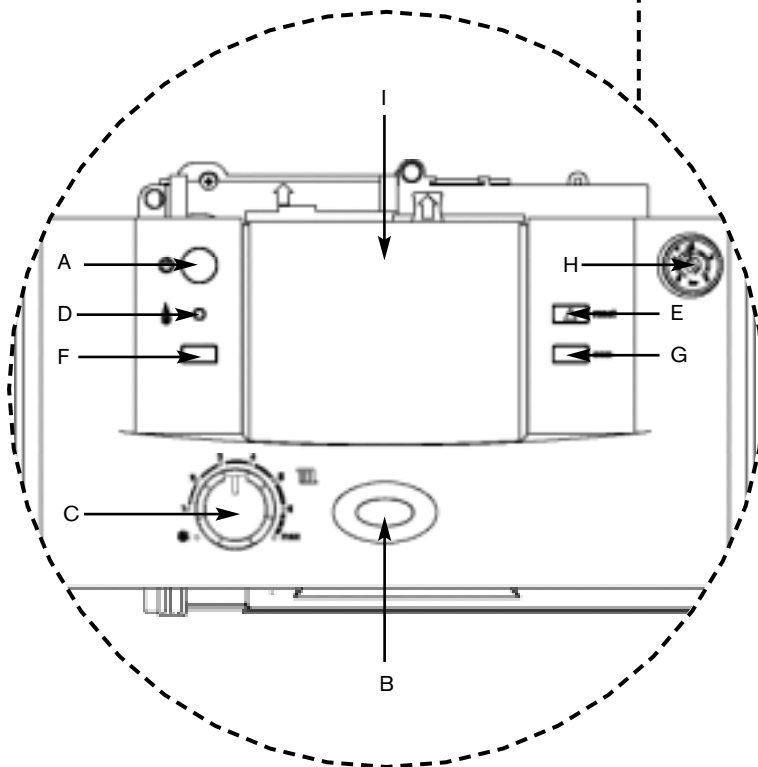
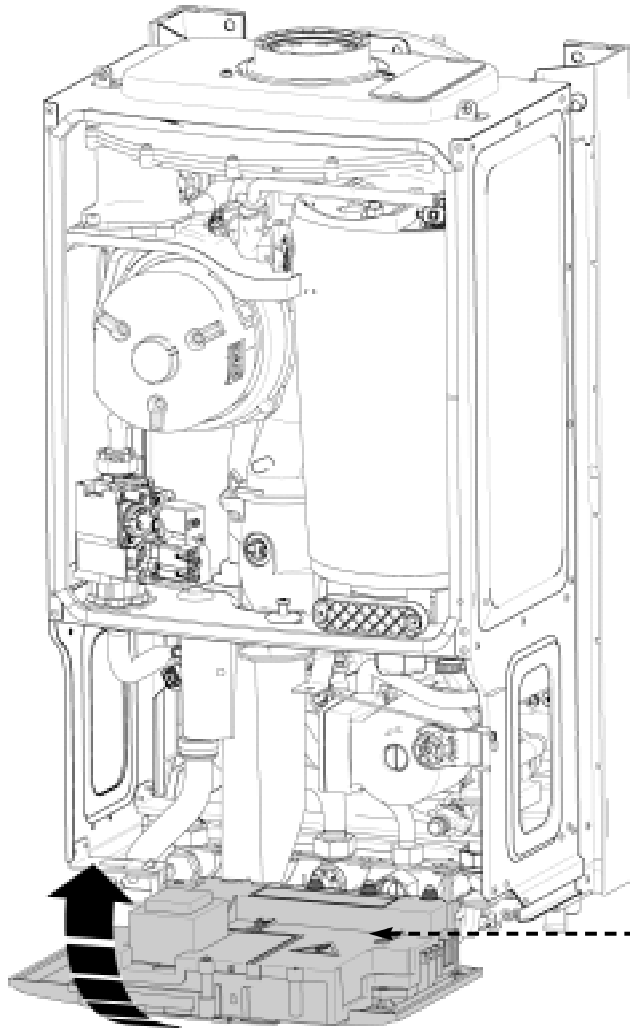

CAUTION: DO NOT PRESS POWER INDICATOR (B) TO RESET BOILER.

IMPORTANT: ARTIFICIALLY SOFTENED WATER MUST NOT BE USED TO FILL THE CENTRAL HEATING SYSTEM.

IMPORTANT: Debris from the system can damage the boiler and reduce efficiency. Failure to comply with the guidelines for the use of water treatment with the appliance will invalidate the appliance warranty.

ENSURE THAT THE SYSTEM HAS BEEN CLEANED AS ON PAGE 8 OF THESE INSTRUCTIONS.

FLUSHING (Central Heating):

- ▶ Switch off the boiler.
- ▶ Open all drain cocks and drain the system while the appliance is hot.
- ▶ Close drain cocks and add a suitable flushing agent at the correct strength for the system condition in accordance with the manufacturer's instructions.
- ▶ Run the boiler/system at normal operating temperature for the time stated by the manufacturer of the flushing agent.
- ▶ Drain and thoroughly flush the system to remove the flushing agent and debris.

INHIBITOR (Central Heating):

- ▶ Check drain cocks are closed and all radiator valves are open before adding a suitable*inhibitor (or combined inhibitor/anti-freeze if the system is exposed to freezing conditions) to the heating system water in accordance with the manufacturers instructions.

*** compatible with aluminium. The pH value of the system water must be less than 8 or the appliance guarantee will be invalidated.**

- ▶ Fill system via a WRAS approved filling loop to between 1 and 2 bar.
- ▶ Vent all radiators; retighten vents when complete. Vent any air from the boiler heat exchanger using a suitable container to collect any water.
- ▶ **Ensure tube outlet is directed away from the fan or any other electrical component to prevent damage. Also place a suitable cover over the fan to prevent any spillage of water onto electrical connections. Ensure the cover is removed after venting.**
- ▶ Vent all radiators.
- ▶ Re-pressurise if necessary to 1 bar.
- ▶ Set all controls to maximum.
- ▶ Record the date when the inhibitor was added to the system on the guarantee card.

NOTE: The concentration of inhibitor in the system should be checked every 12 months or sooner if system content is lost.

The addition of sealing agents to the system water is not recommended as this can cause problems with deposits left in the heat exchanger.

COMMISSIONING

NOTE: When running in the service mode, the boiler will operate both the central heating and the domestic hot water circuits. This is to allow sufficient time for this part of the commissioning procedure. It will be necessary to run water through the domestic hot water circuit to ensure that the boiler will not cycle on low heating demands.

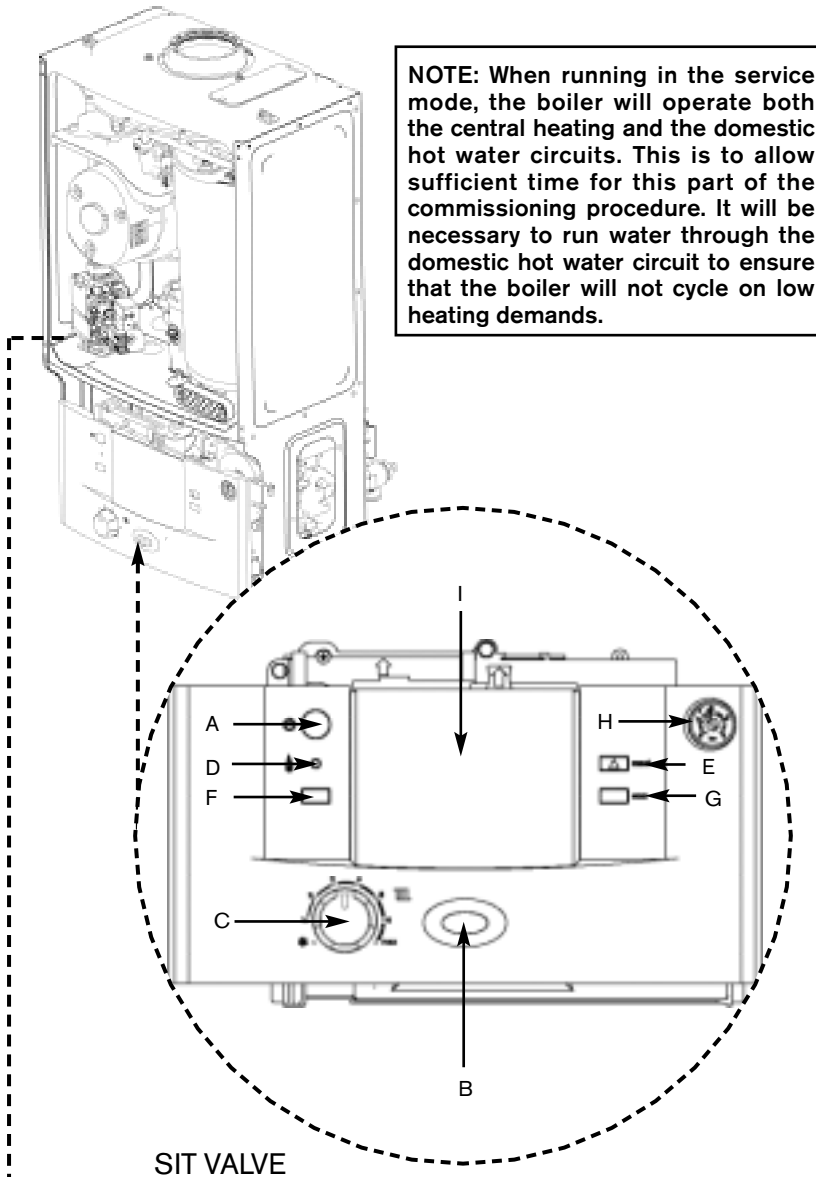

SIT VALVE

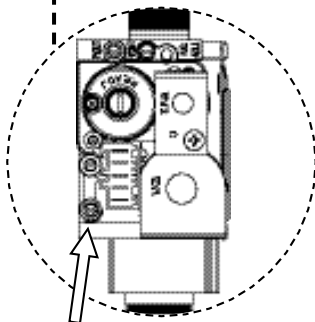

Inlet Test Nipple

- A - On/off button
- B - On/off and fault indicator (BLUE)
- C - Central heating temperature control
- D - Burner indicator (GREEN)
- E - Reset button
- F - Service button
- G - ECO button
- H - System pressure gauge
- I - Cover or optional programmer

DUNGS VALVE

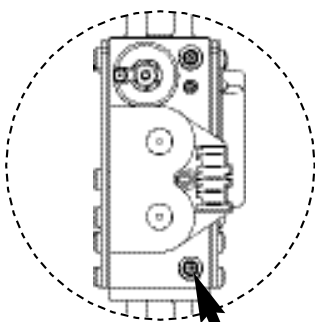

Inlet Test Nipple

THE COMBUSTION FOR THE APPLIANCE IS FACTORY SET.

NO ADJUSTMENT IS REQUIRED IF THE GAS INLET PRESSURE IS CORRECT.

CHECKING GAS INLET PRESSURE:

The inlet pressure to the appliance must be checked using the following procedure:

SETTING THE BOILER TO MAXIMUM:

- 1 Press service button (F) for 10 seconds and set Central Heating temperature to maximum.
- The service button will illuminate continually and the blue power indicator will flash quickly.

MEASURING THE INLET PRESSURE:

- 2 Slacken the screw in the inlet pressure test point and connect a manometer.
 - ▶ Measure the pressure with the boiler running at maximum.
 - ▶ Check the gas supply working pressure at the gas valve inlet point is not less than:
 - N.G. 18.5 mbar
 - L.P.G. 37 mbar
 - ▶ The gas rate should be measured at the gas meter after 10 minutes operation at maximum. See technical data section at the front of this manual.
 - ▶ (LPG) Where a gas meter is not available the CO/CO₂ must be checked to the units shown in the setting of the gas/air ratio.
 - ▶ Ensure inlet pressure is satisfactory with all other gas appliances working.
 - ▶ Replace controls cover. **NOTE:** This boiler is designed with a differential of 20°C across the heating system.

IMPORTANT: Do not continue commissioning until the correct gas pressure is achieved.

- ▶ If pressure is satisfactory press the service button (F) again and the boiler will return to normal operation.
- If left in the service mode the control will return to normal operation after 15 minutes.
- ▶ Re-seal the screw in the gas inlet pressure test point.

DOMESTIC HOT WATER:

Controlling the hot water temperature

The hot water temperature is fixed at 55°C.

DOMESTIC HOT WATER PRE-HEAT:

Pre-heat reduces the time taken to produce hot water at the tap and is controlled by the ECO button (H).

- ▶ Press and hold the ECO button for at least 3 seconds to select either state:

When the ECO button is **not illuminated** the boiler will be in pre-heat mode (which will reduce the time taken to produce hot water at the tap).

OR

When the ECO button is **illuminated** the boiler will be in Economy mode with pre-heat no longer active.

The boiler has been factory set, so there should be no need to adjust any controls.

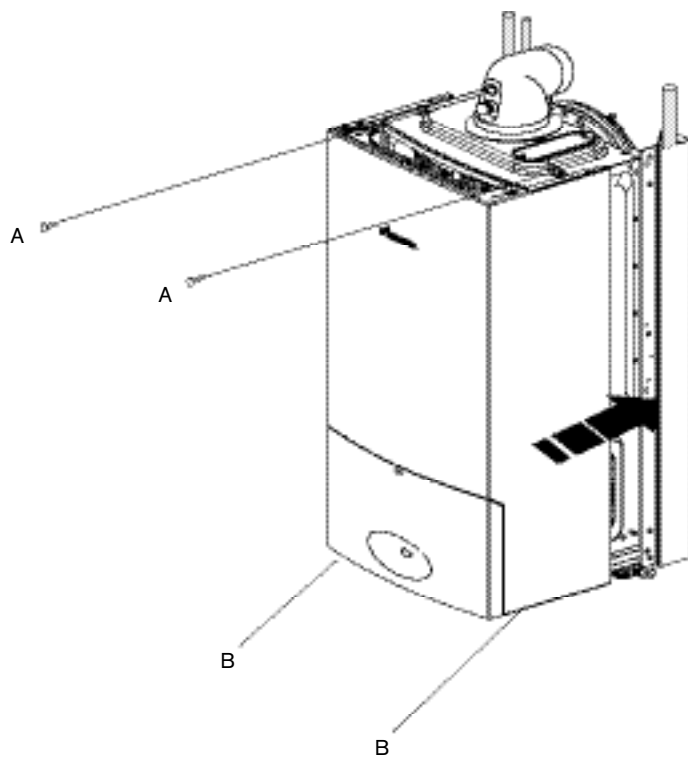

1. REPLACE OUTER CASING:

- Replace outer casing making sure that the securing points are properly located.
- ▶ Replace top two screws (A).
- ▶ Retighten bottom two screws (B).

2. FITTING FASCIA FLAP:

- ▶ Present the flap up to the appliance with the hinge pins facing the appliance.
- ▶ Engage the left hand pin into the grey pivot. The hinge pin and pivot hole are both square, rotate the flap to ensure that the pin is located in the pivot.
- ▶ Support the flap in your left hand and with your right hand, bend the right side down. This should enable you to engage the right hand pin in the pivot. Rotate the flap to ensure that the pins and pivots are located securely.
- ▶ Close the flap.

3. INSTALLING BOTTOM PANEL:

The bottom panel slides onto two ledges (C) either side of the boiler frame.

- ▶ Hold the panel up against the underside of the boiler and slide towards the rear until it is fully engaged.

NOTE: Every time the power to the appliance is turned off and on, the appliance enters a learning mode and may take some time to optimise the boiler performance. This time is variable and is dependant on hot water and central heating demand.

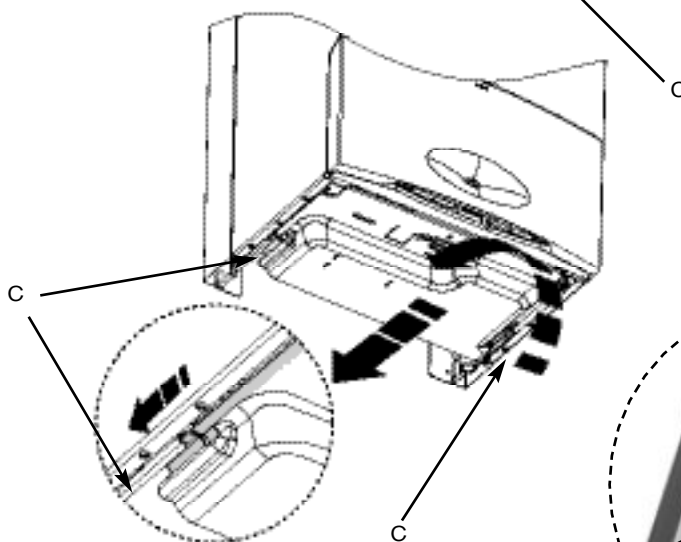
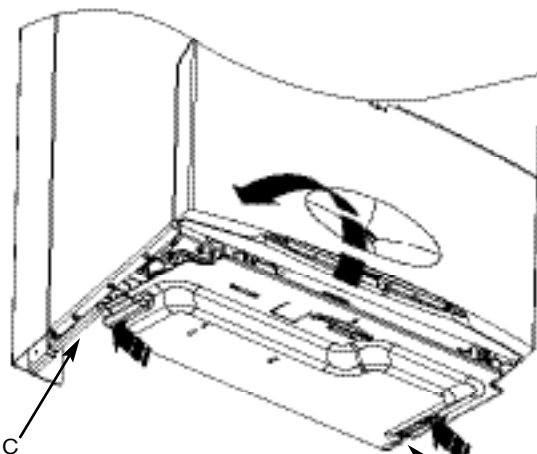

HANDOVER:

- ▶ Complete the Benchmark Gas Boiler Commissioning Checklist.

NOTE: The Benchmark Checklist can be found at the rear of these instructions.

- ▶ Open the fascia cover by gently pressing the centre top of the cover (D).
- ▶ Set up the controls and show the user how to operate all the controls shown in the User Guide.
- ▶ Place the user guide into the tray (E) on the inside of the fascia cover.
- ▶ If the appliance is unused and exposed to freezing conditions, shut off all the mains supplies and drain the system and boiler.

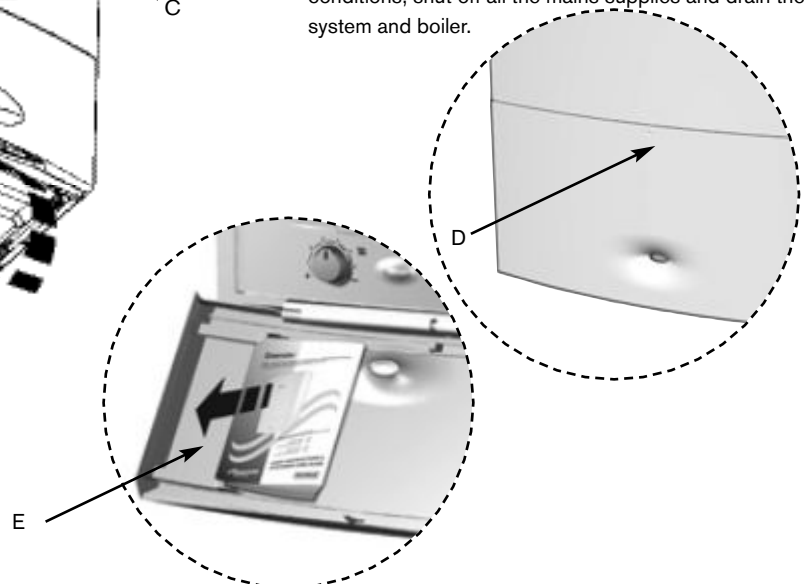

CAUTION: TURN OFF THE GAS SUPPLY AND ISOLATE THE MAINS SUPPLIES BEFORE STARTING ANY WORK AND OBSERVE ALL RELEVANT SAFETY PRECAUTIONS.

IMPORTANT: AFTER REPLACEMENT OF ANY COMPONENTS ALWAYS CHECK FOR GAS SOUNDNESS WHERE RELEVANT AND CARRY OUT FUNCTIONAL CHECKS AS DESCRIBED IN COMMISSIONING. ANY O-RING OR GASKET THAT APPEARS DAMAGED MUST BE REPLACED.

INSPECTION AND SERVICE

IMPORTANT: Any service work must be carried out by competent registered engineers such as British Gas or Corgi registered personnel.

NOTE: A service must NOT be attempted if a CO/CO₂ analyser is NOT available.

- To ensure the continued efficient operation of the appliance it must be checked at regular intervals.
- The frequency of servicing will depend upon the particular installation conditions and usage. However, an annual service is recommended.
- The extent of the service required by the appliance is determined by the operating condition of the appliance when tested by **fully qualified engineers.**
- The service interval record sheet at the rear of these instructions **must** be completed after each service.

Inspection

- 1 Check that the terminal and the terminal guard, if fitted, are clear and undamaged.
 - 2 If the appliance is in a compartment or cupboard check that the specified service space around the appliance is clear.
 - 3 Check all the joints and connections in the system and remake any that show signs of leakage. Refill and re-pressurise if applicable as described in Commissioning.
- ▶ Operate the appliance and take note of any irregularities.
Refer to Fault Finding for rectification procedures.

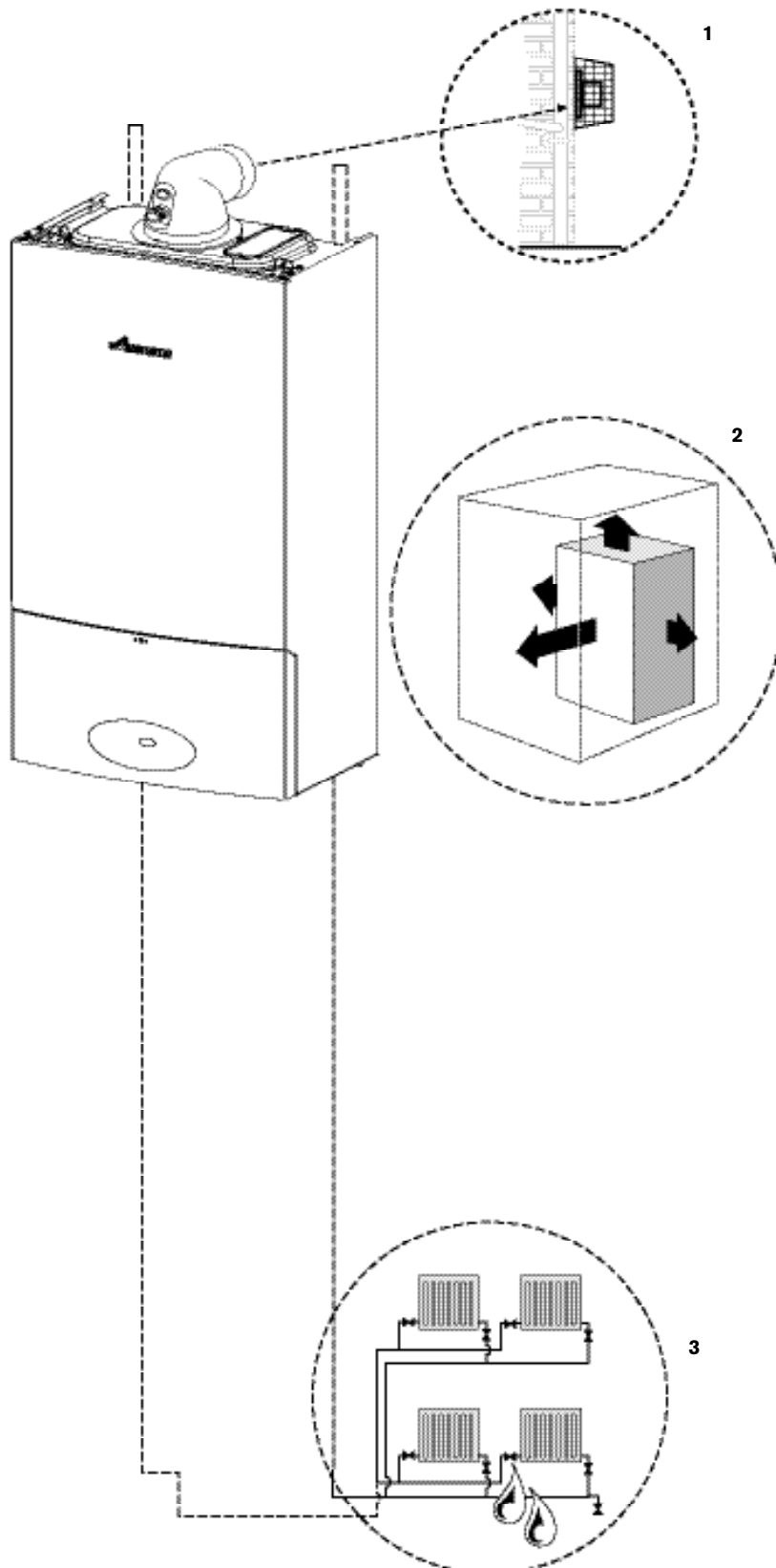

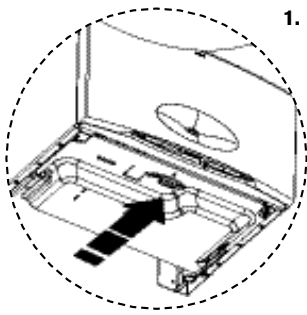

1.

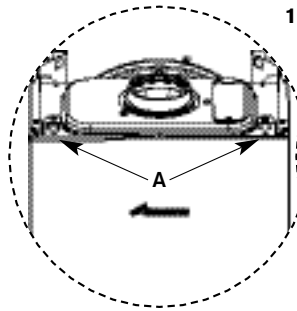

1.1

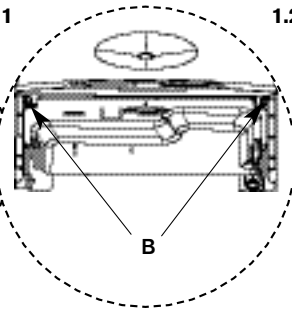

1.2

INSPECTION AND SERVICE

Component Access

1. Removing outer case

1. Remove bottom panel by pulling it forward and off.
- 1.1 Undo and remove 2 screws (A) securing boiler casing at the top of the appliance.
- 1.2 Undo but do not remove the 2 screws (B) securing boiler casing at the bottom of the appliance.
- 1.3 Pull case forward and remove.

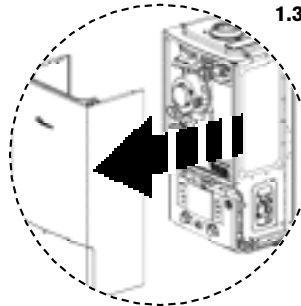

1.3

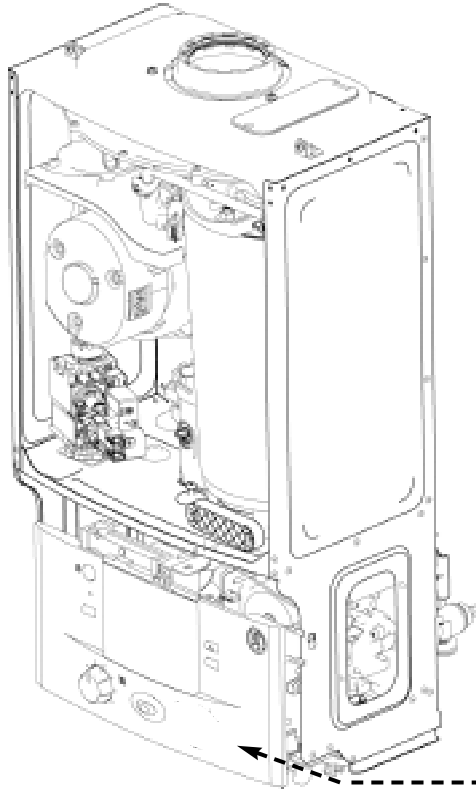

2. Lowering boiler control to the service position

- 2.1 Remove screw (C) securing control.
- 2.2 Gently pull the control forward until it is fully lowered into the service position.

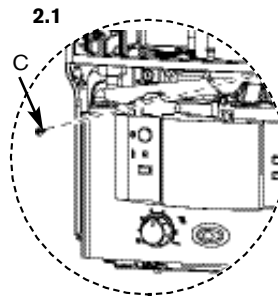

2.1

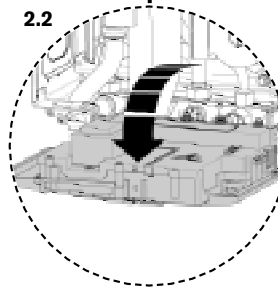

2.2

Setting Boiler to Maximum.

NOTE: When running in the service mode, the boiler will operate both the Central Heating and DHW circuits. This is to allow sufficient time for the setting procedure.

It will be necessary to run water through the DHW circuit to ensure that the boiler will not cycle on low heating demands.

- A - On/off button
- B - On/off and fault indicator (BLUE)
- C - Central heating temperature control
- D - Burner indicator (GREEN)
- E - Reset button
- F - Service button
- G - ECO button
- H - System pressure gauge
- I - Cover or optional programmer

- 1 Press and HOLD service button (F) for 10 seconds and set Central Heating temperature to maximum.
 - The service button will illuminate continually and the blue power indicator will flash quickly.
 - The boiler will stay in this mode for 15 minutes unless the service button is pressed again.
- 2 Pull the cover off and connect a manometer to the fan pressure test point.
 - ▶ After measurement replace test point cover.

Pressure will read **negative** and be greater than:

Natural gas	LPG
24i junior - 3.1 mbar	24i junior - 3.6 mbar
28i junior - 3.9 mbar	28i junior - 4.6mbar

- Pressures measured below these figures will indicate that the heat exchanger will require cleaning.

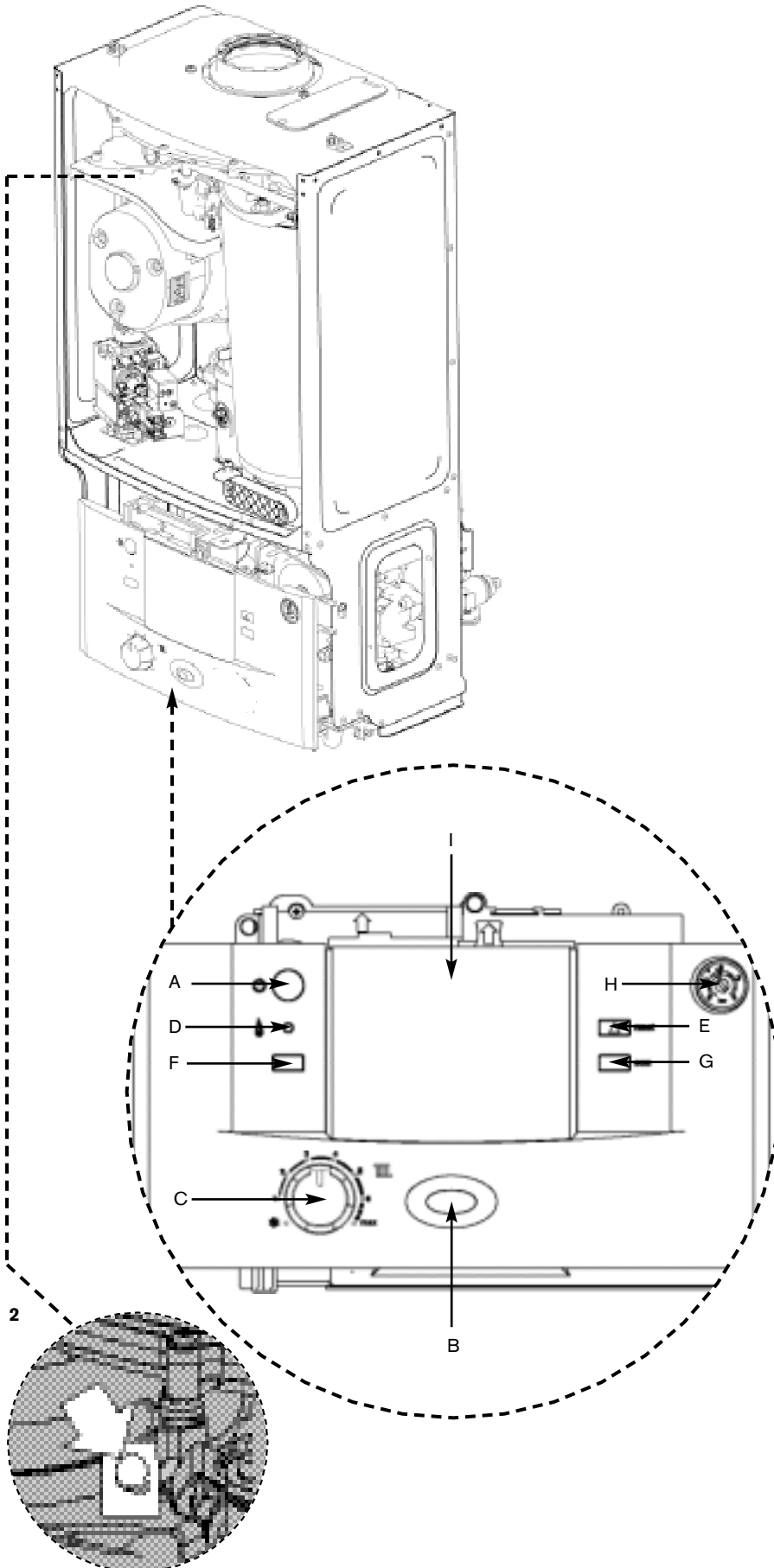

SERVICING & SPARES

COMBUSTION TESTING MUST BE CARRIED OUT BY A COMPETENT PERSON. IT MUST NOT BE ATTEMPTED UNLESS THE PERSON CARRYING OUT THE COMBUSTION CHECK IS EQUIPPED WITH A COMBUSTION ANALYSER CONFORMING TO BS 7927 AND IS COMPETENT IN IT'S USE.

IMPORTANT:

▶ IF THE JOINT BETWEEN THE AIR/GAS MANIFOLD AND THE HEAT EXCHANGER IS DISTURBED THE SEALING GASKET MUST BE REPLACED.

▶ AFTER COMPLETING THE SERVICE OF THE APPLIANCE, THE CO/CO₂ MUST BE CHECKED AND SET TO THE LIMITS SHOWN IN THE "SETTING THE AIR/GAS RATIO"

To Clean the Heat Exchanger

There is a special accessory kit available specifically designed for cleaning the heat exchanger. If required order 7 716 192 312.

- 1 With outer case and base panel removed and the power isolated from the appliance, remove the cover panel (A) by removing the retaining screw (B).
- 2 Remove clip (C) from gas valve outlet.
 - ▶ Pull gas adjustment assembly (D) or outlet elbow (E) free from the plastic connection on the gas valve.
 - ▶ Pull gas adjustment assembly (D) or outlet elbow (E) forward to clear case.

Cleaning Syphon

- 3 There is no need to remove the Syphon Assembly to clean. To drain debris from the syphon, release the clips and remove the drainage cap (E) from the bottom of the syphon. Catch the debris and condensate from the syphon into a suitable container. Re-fit the drainage cap (E) to bottom of the syphon.

Remove control retaining screw

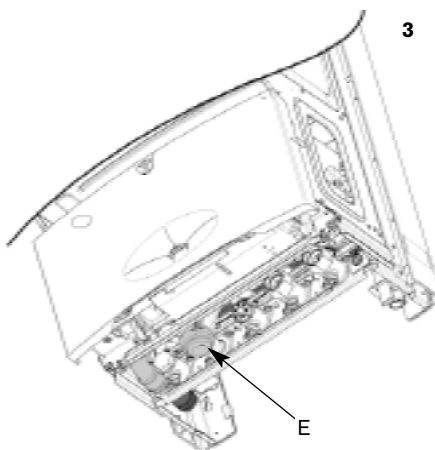
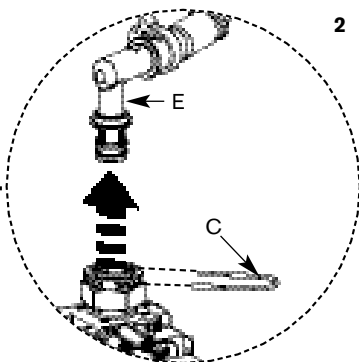
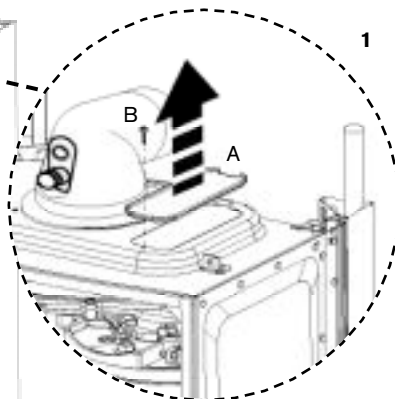
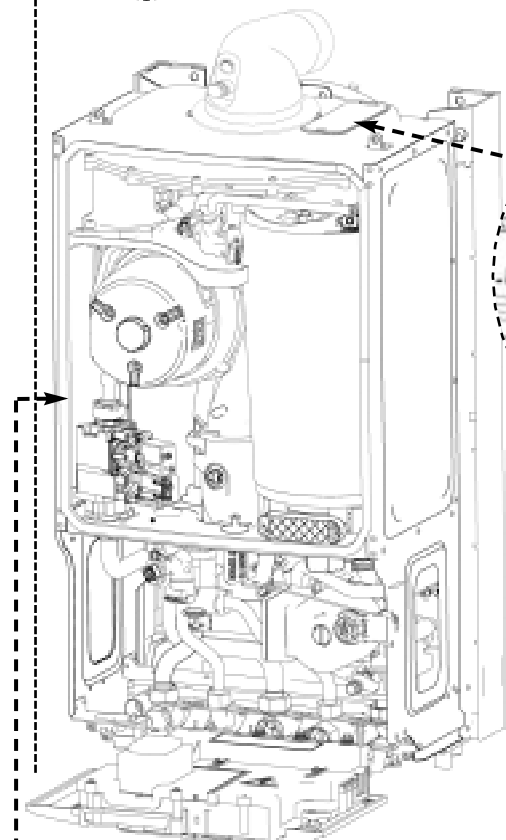
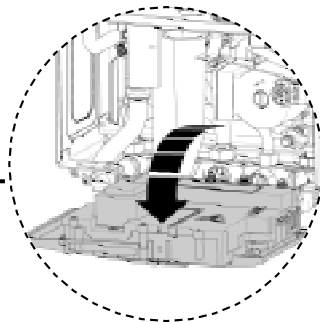
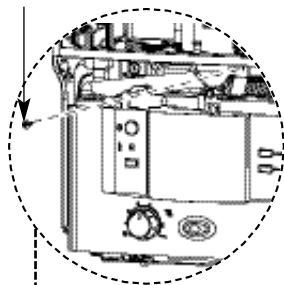

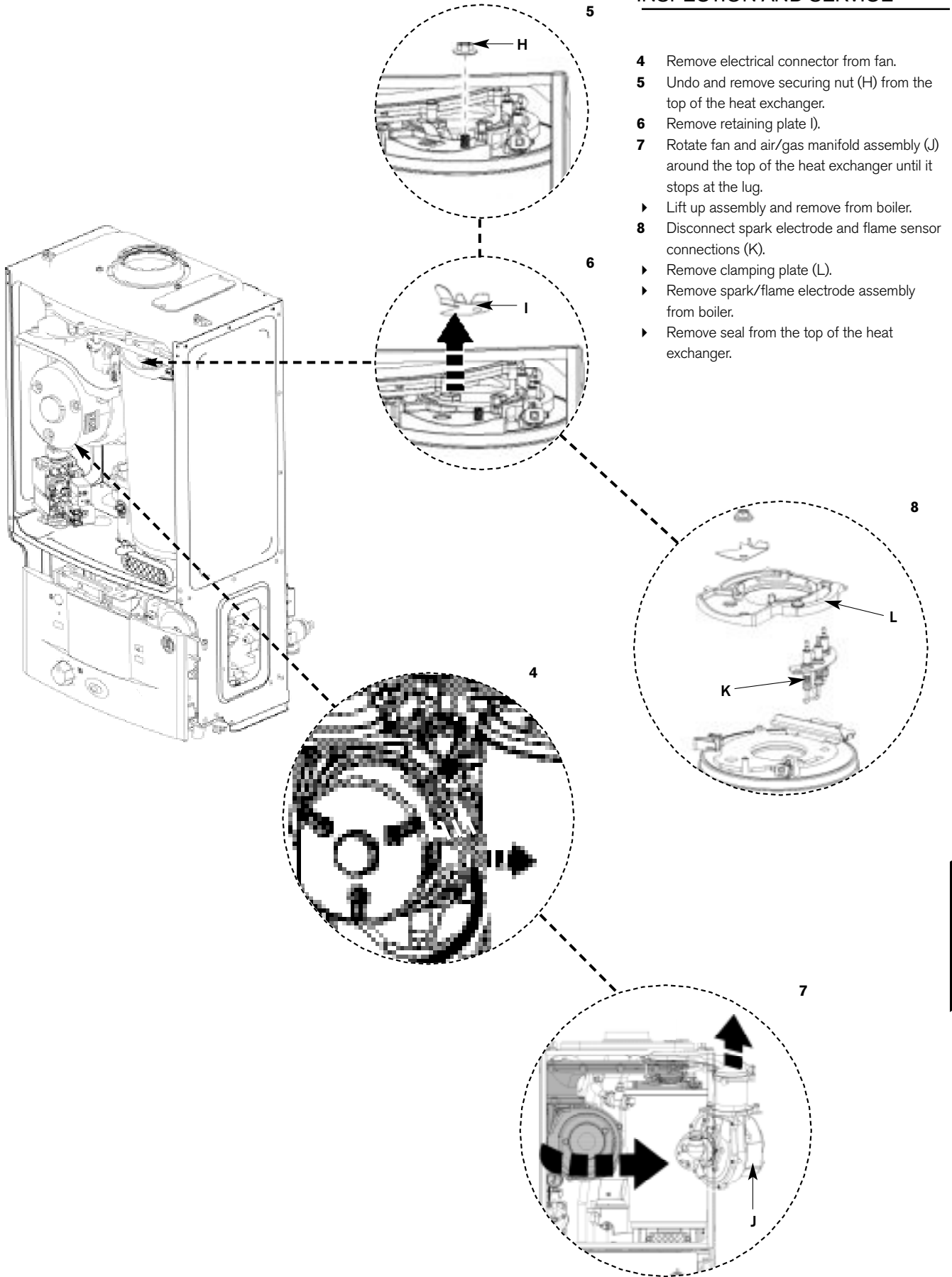

- 4 Remove electrical connector from fan.
- 5 Undo and remove securing nut (H) from the top of the heat exchanger.
- 6 Remove retaining plate (I).
- 7 Rotate fan and air/gas manifold assembly (J) around the top of the heat exchanger until it stops at the lug.
 - ▶ Lift up assembly and remove from boiler.
- 8 Disconnect spark electrode and flame sensor connections (K).
 - ▶ Remove clamping plate (L).
 - ▶ Remove spark/flame electrode assembly from boiler.
 - ▶ Remove seal from the top of the heat exchanger.

SERVICING & SPARES

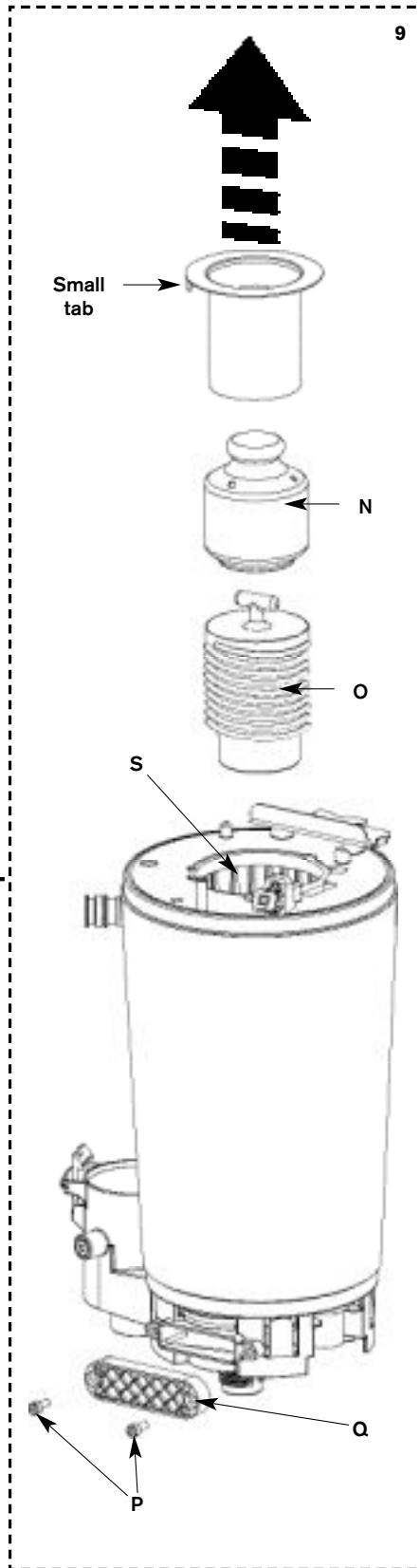
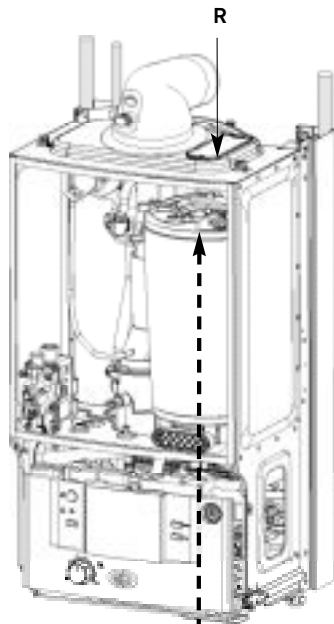

IMPORTANT: IF THE JOINT BETWEEN THE AIR/GAS MANIFOLD AND THE HEAT EXCHANGER IS DISTURBED THE SEALING GASKET MUST BE REPLACED.

INSPECTION AND SERVICE

- 9**
- ▶ Remove burner (M).
 - ▶ Remove top baffle (N).
 - ▶ Remove lower baffle (O).
 - ▶ Remove the two pozi-drive screws (P) retaining the access cover (Q) on the sump.
 - ▶ Access the heat exchanger flue ways by inserting the cleaning brush (7 716 192 312) through the top access hole in the casing (R).
 - ▶ Clean heat exchanger flue ways (S) using the cleaning brush (7 716 192 312) removing any debris from the access point in the sump.

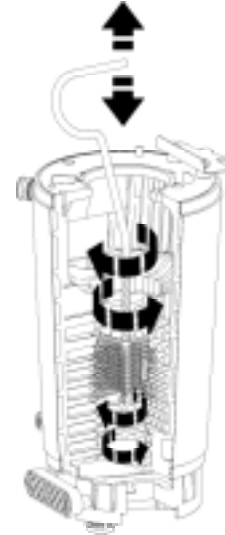

Clean around sealing surface on sump and replace access cover (Q). Using a suitable container to collect water from syphon connection at the base of the boiler flush heat exchanger with water.

- ▶ Re-assemble ensuring that the lower baffle (O) and the top baffle (N) are refitted correctly.
- ▶ When re-fitting the burner ensure that it fits centrally within the heat exchanger and location tabs are situated in location holes.
- ▶ **Ensure seal is replaced with new seal and is correctly fitted.**
- ▶ Check the syphon unit for blockage before refitting to boiler.
- ▶ **Reassemble and check combustion as stated in "SETTING THE AIR/GAS RATIO" section.**

NOTE: To show the heat exchanger more clearly it has been shown external to the appliance

THE BAFFLES (O) AND (N) MUST BE REFITTED INTO THE HEAT EXCHANGER AS SHOWN IN 9. FAILURE TO DO SO MAY RESULT IN DAMAGE TO THE BOILER

CAUTION: TURN OFF THE GAS SUPPLY AND ISOLATE THE MAINS SUPPLIES BEFORE STARTING ANY WORK AND OBSERVE ALL RELEVANT SAFETY PRECAUTIONS.

IMPORTANT: AFTER REPLACEMENT OF ANY COMPONENTS ALWAYS CHECK FOR GAS SOUNDNESS WHERE RELEVANT AND CARRY OUT FUNCTIONAL CHECKS AS DESCRIBED IN COMMISSIONING. ANY O-RING OR GASKET THAT APPEARS DAMAGED MUST BE REPLACED.

REPLACEMENT OF PARTS

1. Removing outer case

- 1.1 Undo 4 screws (A) securing boiler casing.
- 1.2 Pull case forward and remove.
 - ▶ To remove bottom tray, pull forward on the tag on the underside of the tray.

The following components can be replaced with the outer case removed:
Primary sensor
Overheat thermostat
Flue limit thermostat

2. Primary sensor

- ▶ Remove electrical connection (B) by pulling upwards. Squeeze retaining clip on plastic moulding (C) and pull sensor (D) upwards until clear of pocket in heat exchanger.
- ▶ Coat new sensor with heat conductive paste and replace.

3. Overheat thermostat

- ▶ Remove two electrical connectors from thermostat.
- ▶ Slacken and remove fixing screw and thermostat.
- ▶ When replacing ensure thermostat sits correctly on surface of the casting with the left hand side of thermostat siting up against the shoulder.

NOTE: It is essential that the mating surface of the thermostat is coated with heat conductive paste.

4. Flue overhear thermostat

4.1 (with grommet)

- ▶ Remove electrical connections.
- ▶ Undo the flue connection from the sump and push the flue tube up.
- ▶ Push the flue limit thermostat outwards from the sump.

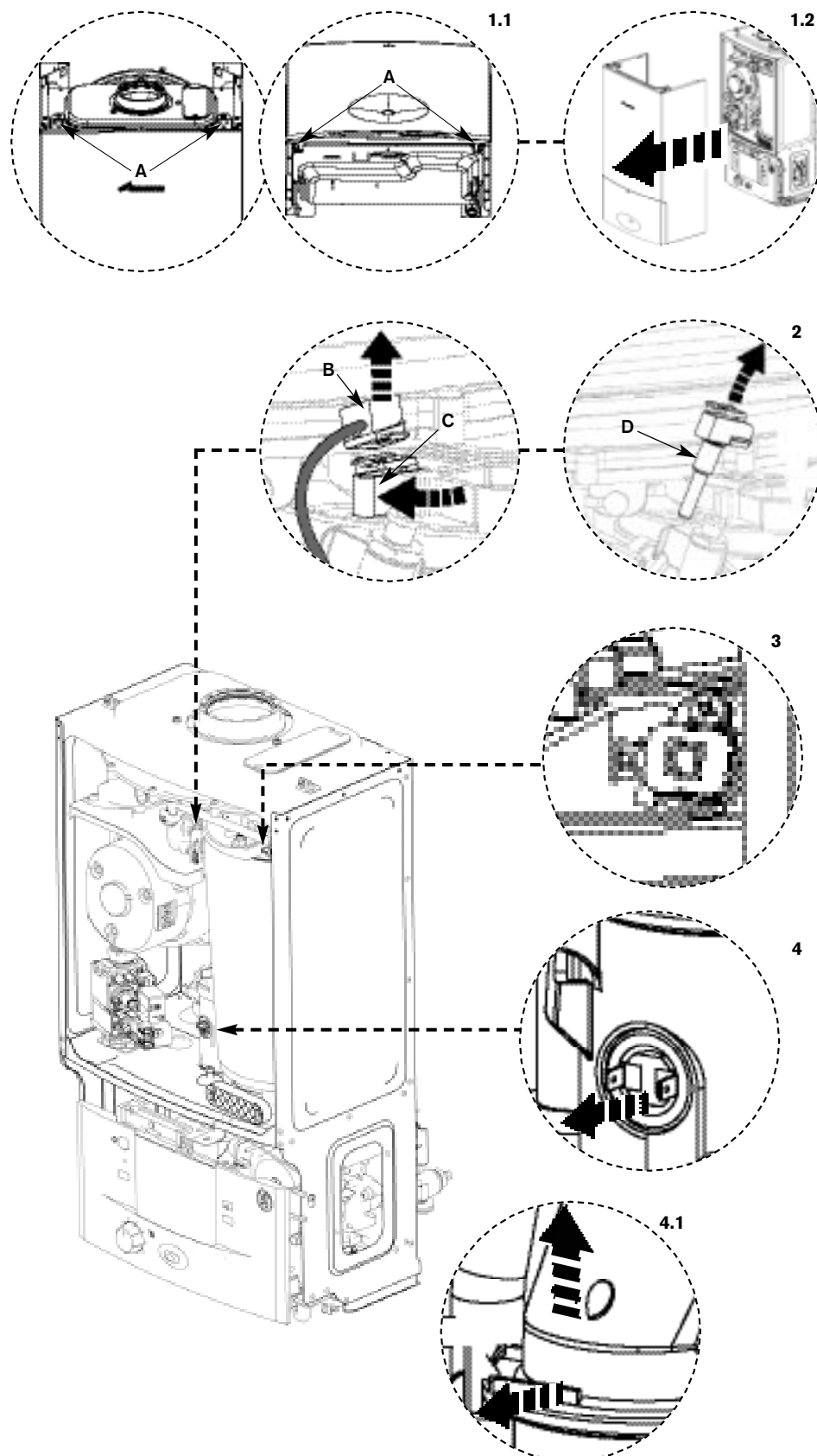

REPLACEMENT OF PARTS SIT AND DUNGS VALVES

The following components require the control to be moved in to the service position:

Gas valve
Syphon
PCB fuse
Transformer

REMOVAL OF THE VALVE IS THE SAME FOR BOTH SIT AND DUNGS VALVES. THE SIT VALVE IS SHOWN IN THE DIAGRAM.

REPLACEMENT OF THE GAS VALVE MUST NOT BE CARRIED OUT IF A CO/CO2 ANALYSER IS NOT AVAILABLE.

5. Moving boiler control to service position

- 5.1 Remove screw (A) securing control.
5.2 Gently pull forward.

6. Gas valve

- ▶ Isolate gas supply at boiler gas cock.
- 6.1 Remove wire clip from gas valve outlet then pull gas adjustment assembly free from plastic connector and pull forward clear of case.
- 6.2 Undo bottom gas connection to gas valve.
- 6.3 Undo two securing screws (C) on the underside of casing.
- ▶ Pull valve up and forward out of boiler.
- ▶ Disconnect electrical connections.
- ▶ Replace valve with new seals and check for gas soundness.

Note: The valve will require setting; follow procedure "Setting the air/gas ratio".

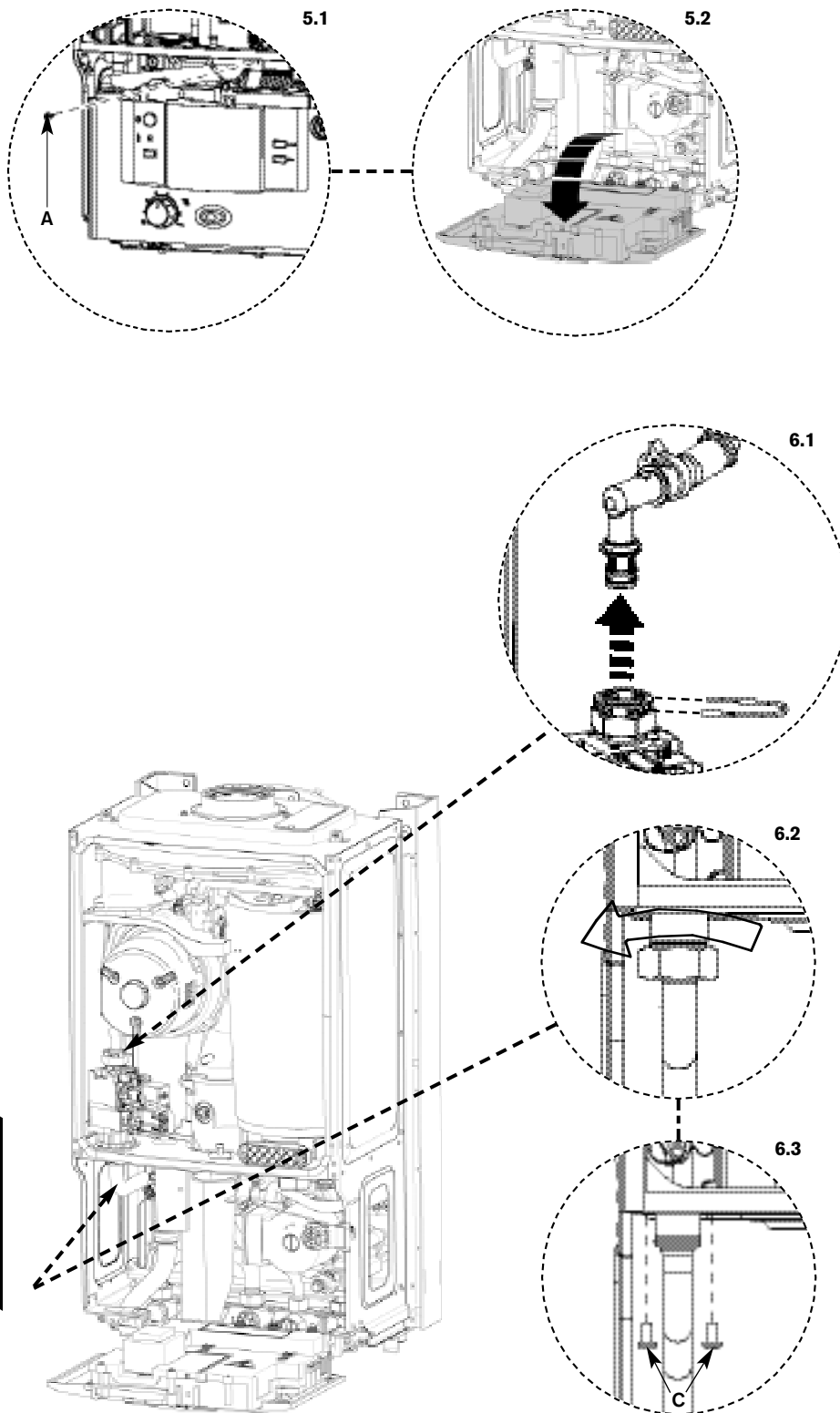

7. Access to boiler control components

- ▶ Remove 3 screws (A) and remove cover from control.

8. PCB fuse

- ▶ Remove fuse F1(B) from the PCB and replace.
- ▶ There is a spare fuse clipped into the underside of the electrical cover.

9. Transformer / PCB

- ▶ Disconnect all electrical connections from the control.
- ▶ Remove 5 screws (C) retaining the rear panel of the control and remove panel.

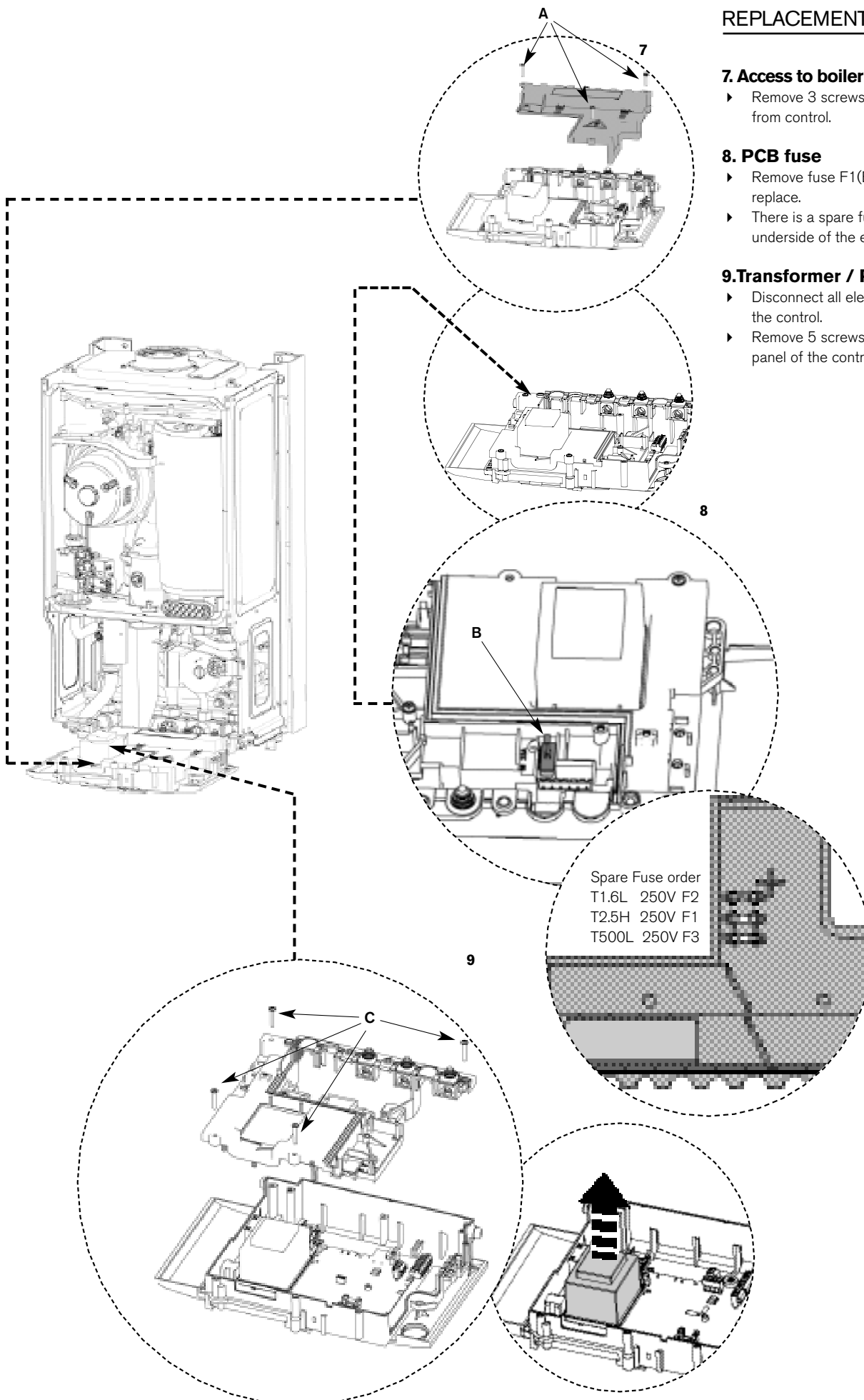

10. Replacing control

IMPORTANT:

Do not replace the control unit if a CO/CO₂ analyser is NOT available.

The control is supplied within its plastic housing. The complete unit must be replaced.

- ▶ Remove ALL electrical connections from the control PCB including where cables run through restraints. These can be unclipped from the plastic moulding noting their position.
- ▶ Remove the code plug (B). The code plug should be left attached to the frame of the boiler by its plastic safety thread.

10.1 Remove the 3 screws (C) retaining the front fascia making sure to support the fascia when removing the last screw.

10.2 Using a suitable tool (D), press the button (E) upwards and slide the control support bracket (F) to the left.

10.3 Support the control and unclip control support cable (G) from the boiler frame.

- ▶ Remove the support cable and fit to the new control.
- ▶ Remove appropriate cable restraints from the new control box.
- ▶ Fit control to the boiler.
- ▶ Re-connect support cable to the boiler and all electrical connections to the new control.

NOTE:

After re-assembly, check the CO/CO₂ levels as described in the setting of the air/gas ratio section.

IMPORTANT: ENSURE CODE PLUG IS RE-FITTED TO THE NEW CONTROL. IF THIS IS NOT DONE THE BOILER WILL INDICATE ERROR AND WILL NOT FUNCTION.

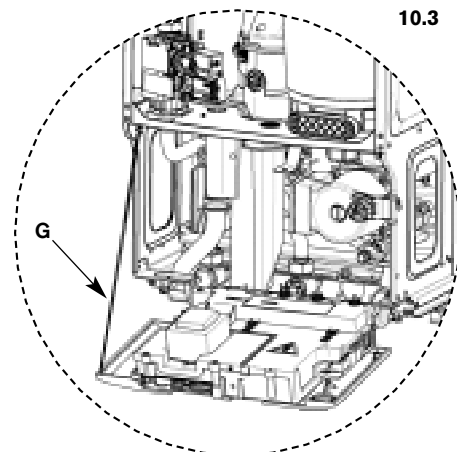
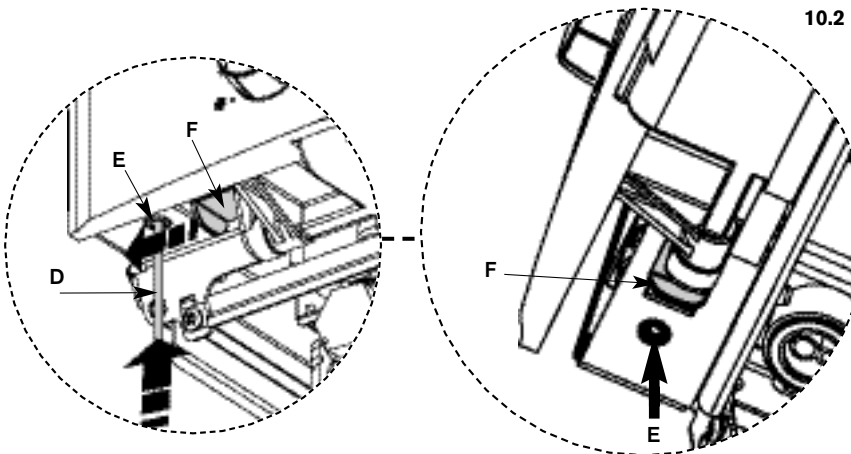
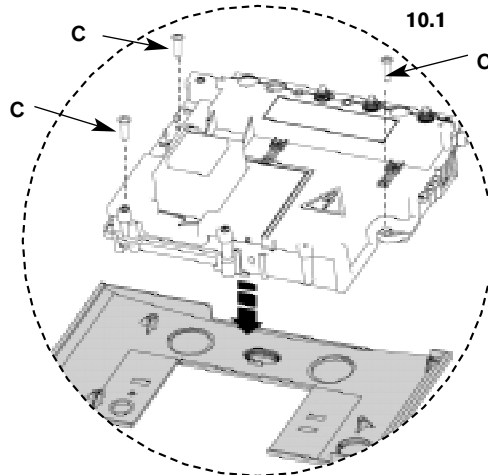
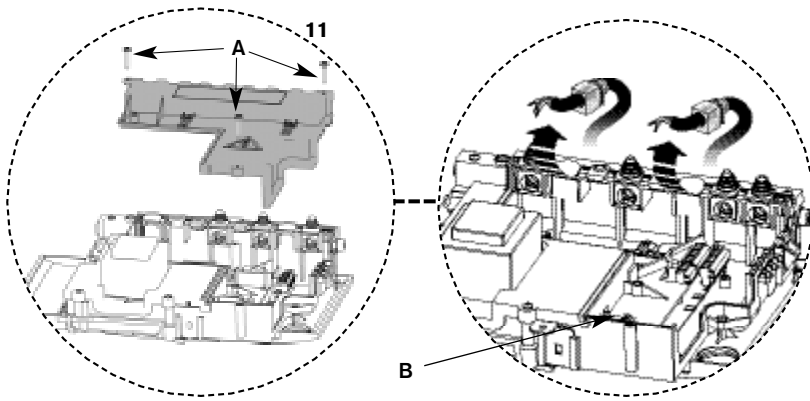

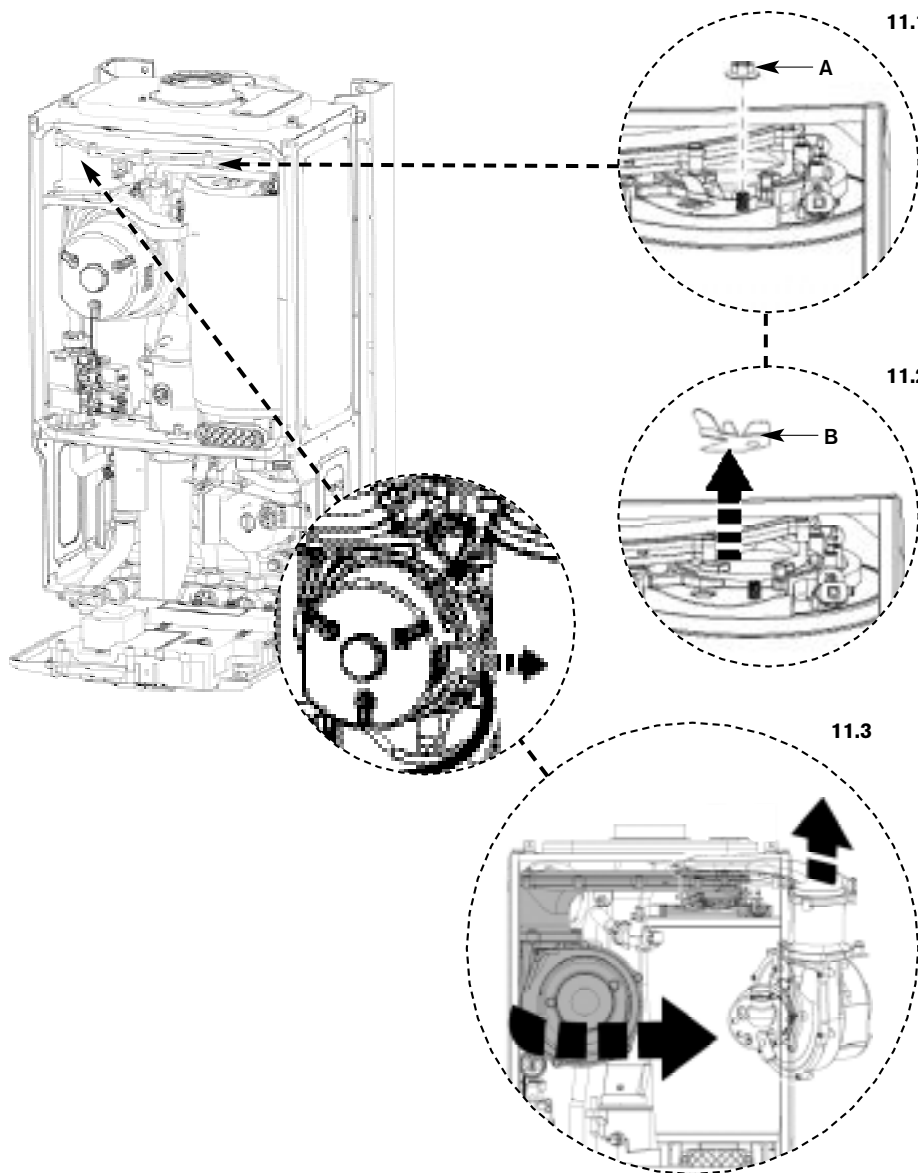

11.1

REPLACEMENT OF PARTS

The following components require the air / gas manifold and fan assembly to be removed:

Pressure switch
Fan
Electrode assembly
Burner
Heat exchanger

11.2

IMPORTANT: IF THE JOINT BETWEEN THE AIR/GAS MANIFOLD AND THE HEAT EXCHANGER IS DISTURBED THE SEALING GASKET MUST BE REPLACED.

11.3

IMPORTANT: AFTER REASSEMBLY THE COMBUSTION MUST BE CHECKED USING THE PROCEDURE IN THE SECTION "SETTING THE AIR/GAS RATIO". MEASUREMENT AND SETTING (IF NECESSARY) OF THE GAS RATIO MUST NOT BE ATTEMPTED UNLESS THE PERSON IS EQUIPPED WITH A COMBUSTION ANALYSER CONFORMING TO BS 7927 AND IS COMPETENT IN ITS USE.

11. Air / gas manifold and fan assembly

- ▶ Remove electrical connector from fan.
- ▶ Remove wire clip from gas valve outlet then pull gas adjustment assembly free from plastic connector and pull clear of case (see 6.1).

11.1 Undo and remove securing nut (A) from the top of the heat exchanger.

11.2 *Remove retaining plate (B).

11.3 Rotate fan and air/gas manifold assembly (shaded) around the top of the heat exchanger until the lug on the air/gas manifold is visible.

- ▶ Lift up assembly and remove from boiler.

NOTE:

After re-assembly, check the CO/CO₂ levels as described in the setting of the air/gas ratio section.

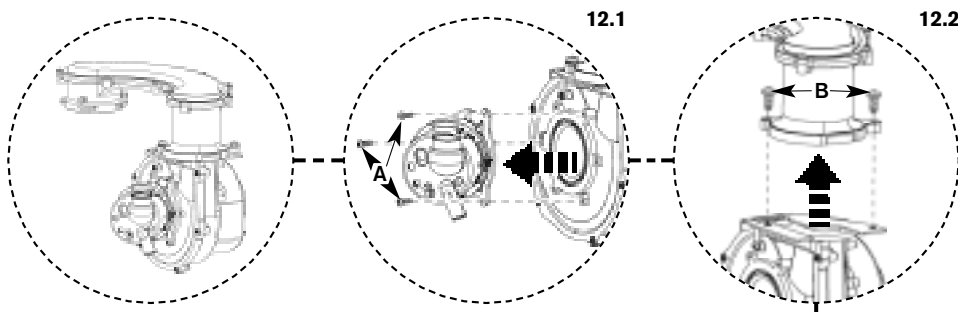

12. Fan

- 12.1 Remove 3 screws (A) retaining mixing chamber.
- 12.2 Remove 2 screws (B) retaining the fan to the air/gas manifold.
- 12.3 Remove screw (C) retaining plate and remove.
 - ▶ Re-assemble with new fan ensuring seals are correctly fitted.
 - Check CO/CO₂ levels as described in the "setting the air/gas ratio" section.

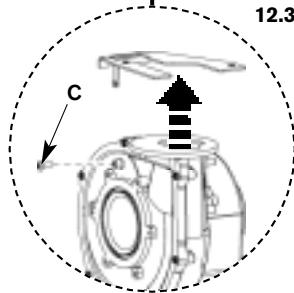

13. Electrode assembly

- ▶ Disconnect spark electrodes and flame sensor connection.
- ▶ Remove clamping plate (D).
- ▶ Remove spark/flame electrode assembly (E) from heat exchanger.
- Check CO/CO₂ levels as described in the "setting the air/gas ratio" section.

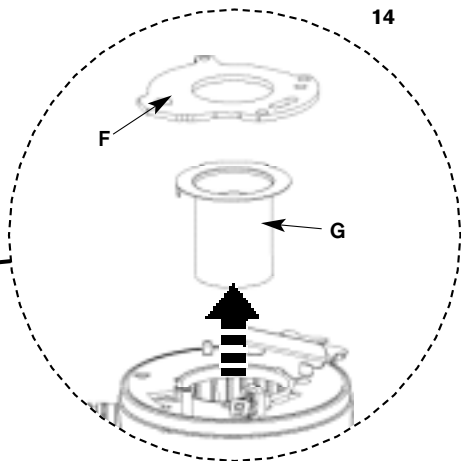
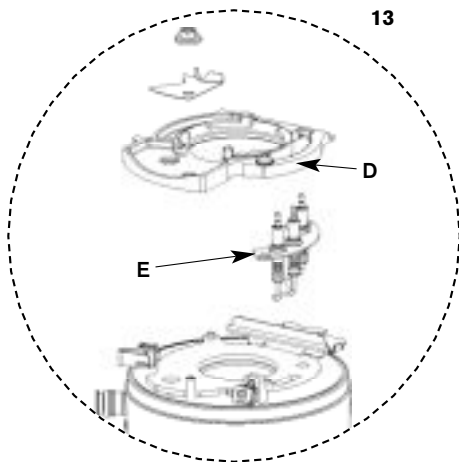

14. Burner

- ▶ Remove seal (F) from the top of the heat exchanger.
- ▶ Remove burner (G).
- ▶ Replace new burner in correct position.
- ▶ Ensure that burner tab fits correctly into hole.
- ▶ Ensure that the seal is replaced with a new one.
- Check CO/CO₂ levels as described in the "setting the air/gas ratio" section.

15. Heat Exchanger

- ▶ Isolate flow and return valves then drain the boiler.
- ▶ Remove syphon.
- 15.1 Remove clip from plastic elbow on the flow pipe and pull flow pipe away from heat exchanger.
- 15.2 Remove plastic nut from the bottom of the boiler.
- 15.3 Rotate lever to release return pipe.
- 15.4 Undo flue connection from sump.
 - ▶ Pull heat exchanger assembly up to clear.
 - ▶ Reassemble and check combustion as stated in the gas conversion section.
 - Check CO/CO₂ levels as described in the "setting the air/gas ratio" section.

IMPORTANT: IF THE JOINT BETWEEN THE AIR/GAS MANIFOLD AND THE HEAT EXCHANGER IS DISTURBED THE SEALING GASKET MUST BE REPLACED.

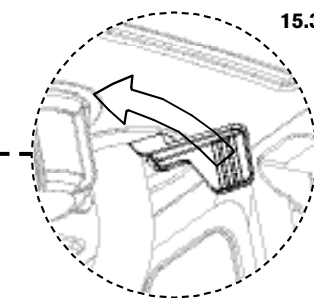
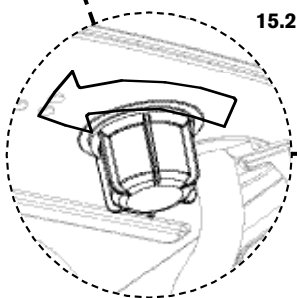
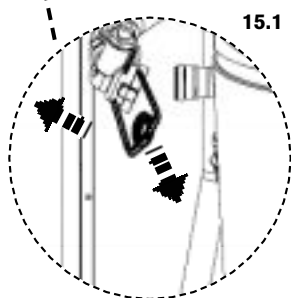
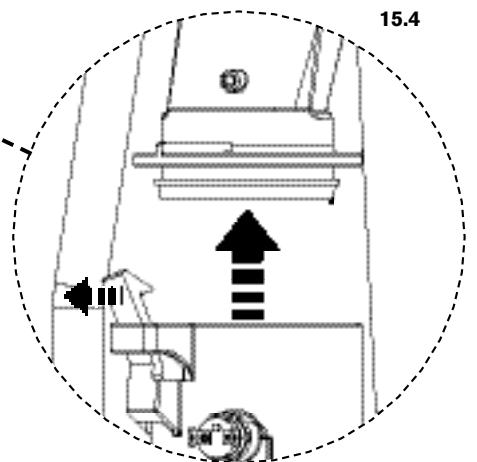

SERVICING & SPARES

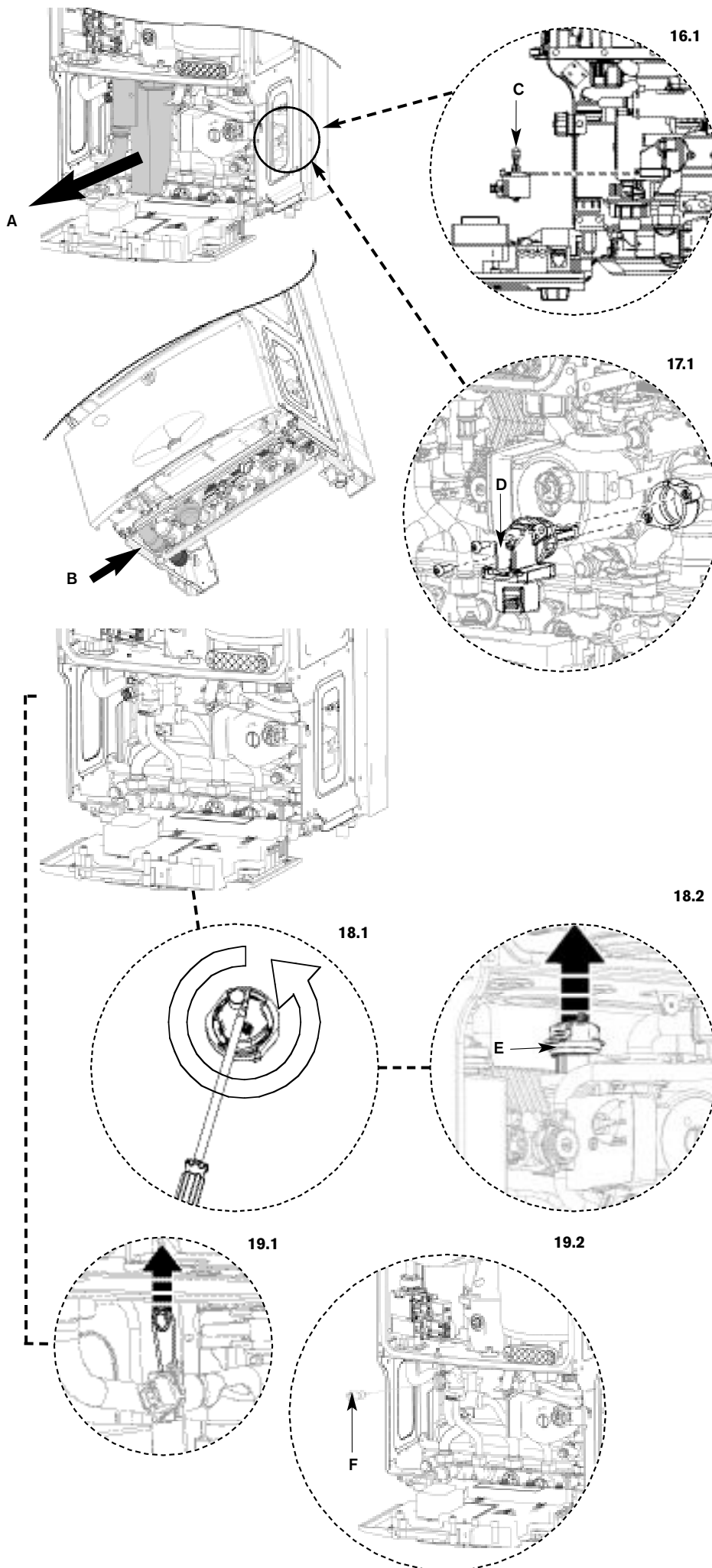

NOTE:

Removal of the syphon assembly will give access to Auto air vent.

To release the syphon from the sump connection, pull towards you (A).

Disconnect the discharge hose (B) at the plumbing manifold.

Remove the complete syphon assembly.

16. Diverter valve motor

- ▶ Ensure the appliance is in service mode (there is no need to drain the appliance).
- ▶ Disconnect the electrical connector from the diverter valve motor.
- ▶ Remove diverter valve cover, if fitted

16.1 Pull the motor assembly (A) towards you. The assembly will slide free from the valve.

- ▶ To refit, follow the above in reverse.

17. Diverter valve

- ▶ Ensure the appliance has been fully drained.
- ▶ Disconnect the electrical connector from the diverter valve motor.
- ▶ Undo the two screws holding the valve to the plastic housing.
- ▶ Remove diverter valve cover, if fitted

17.1 Withdraw the valve (B) and clean the valve chamber if necessary.

- ▶ To refit, follow the above in reverse. Ensure any seals that have been disturbed are renewed.

18. Auto air vent

- ▶ Ensure the appliance has been fully drained.

18.1 Use a screwdriver or similar to rotate the air vent anticlockwise.

18.2 Lift the air vent (C) out of the housing and remove.

- ▶ To refit, follow the above in reverse.

19. DHW temperature sensor

- ▶ Ensure the domestic hot water circuit is fully drained (see draining the domestic hot water).
- ▶ Disconnect the electrical connection from the sensor.

19.1 Withdraw the spring clip.

19.2 Withdraw the sensor (D) from the housing.

- ▶ To refit, follow the above in reverse.

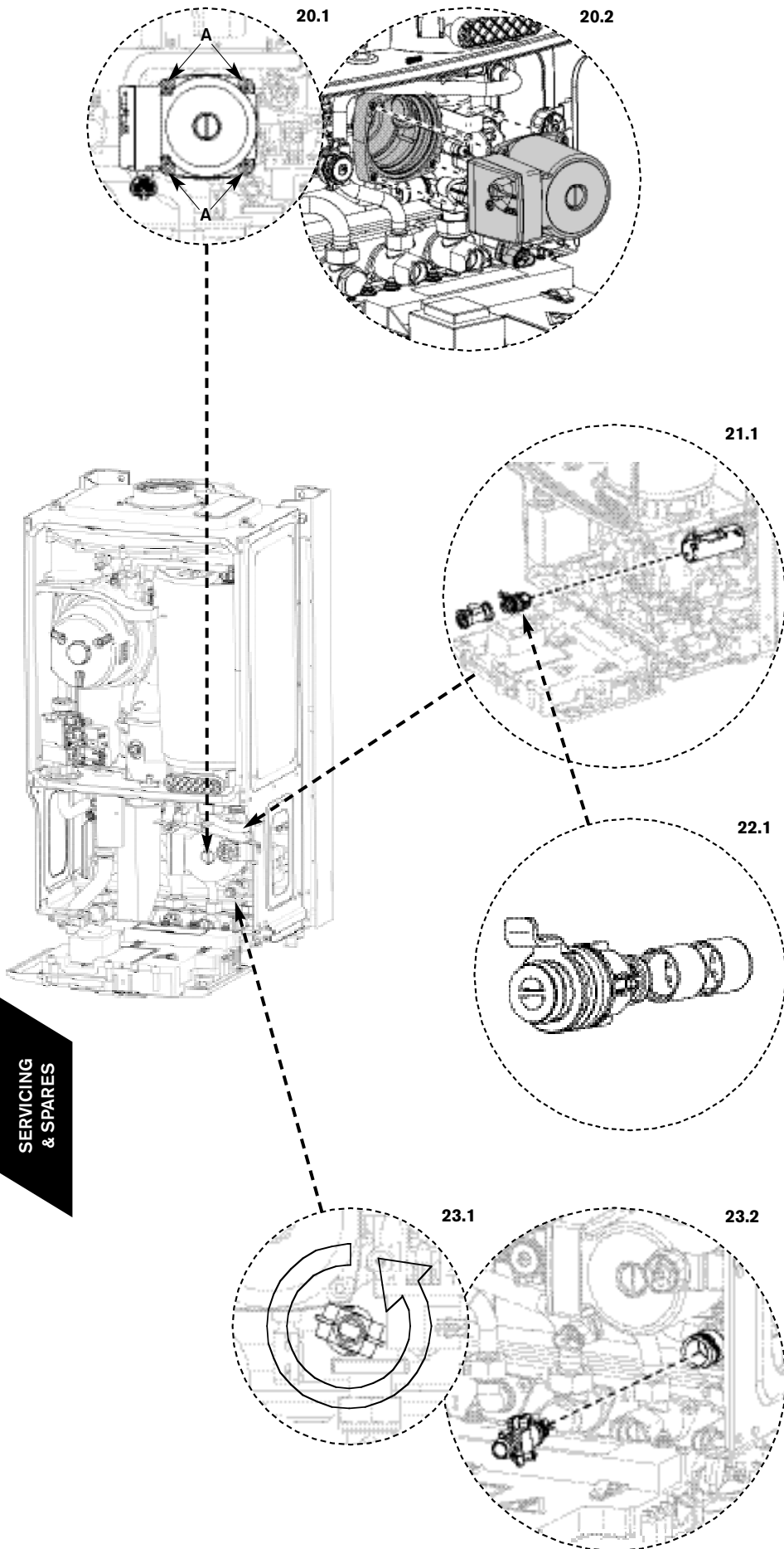

20. Pump head

- ▶ Ensure the boiler is fully drained (see draining the appliance).
- ▶ Disconnect the electrical connection from the bottom of the pump.
- 20.1** Remove the four Allen bolts (A) securing the pump at each corner.
- 20.2** Gently pull the pump towards you and remove.
 - ▶ To refit, follow the above in reverse.

Pressure gauge

- ▶ Ensure the appliance has been fully drained (see draining the appliance).
- ▶ Withdraw the spring clip from the pressure sensing head housing.
- ▶ Undo the nut on the rear of the pressure gauge.
- ▶ Remove the pressure sensing head and pressure gauge capillary from the housing.
- ▶ To refit, follow the above in reverse. **DO NOT** omit the washer from the capillary when fitting a replacement gauge.

21. Flow sensor, flow restrictor housing and filter

- ▶ Ensure the domestic hot water circuit is fully drained (see draining the domestic hot water).
- ▶ Disconnect the electrical connection to the turbine.
- ▶ Remove the spring clip from the housing and move the brass pipe to one side.
- 21.1** Withdraw the flow sensor and filter from the housing.
 - ▶ Using the cartridge tag, withdraw the flow restrictor housing. If the regulator housing has become stuck, a pair of long nosed pliers may be used to grip the housing.
 - ▶ To refit, follow the above in reverse. Ensure any seals that have been disturbed are renewed.

22. Flow regulator

- ▶ Remove the flow restrictor housing (See Removing the flow sensor, flow restrictor housing and filter).
- 22.1** Using a small Allen key or similar, push the flow restrictor cartridge out of it's housing.
 - ▶ To refit, follow the above in reverse. Ensure any seals that have been disturbed are renewed.

23. Drain tap

- ▶ Ensure the appliance has been fully drained.
- 23.1** Rotate the drain tap fully anticlockwise.
- 23.2** Withdraw the drain tap from its housing
 - ▶ To refit, follow the above in reverse. Ensure any seals that have been disturbed are renewed.

24.1

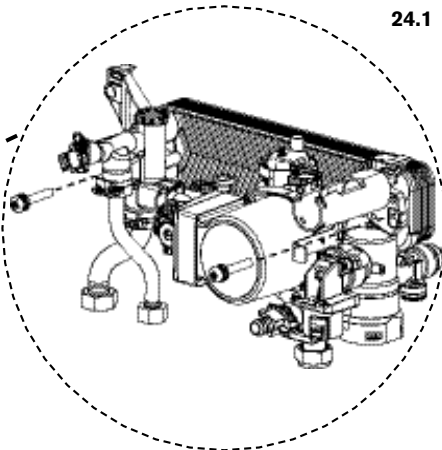
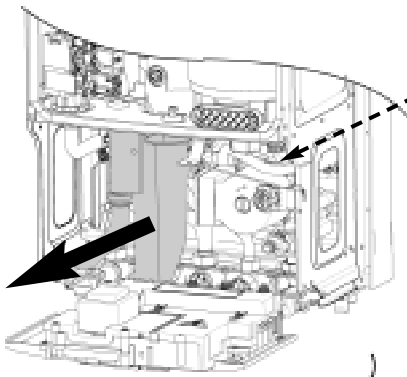

NOTE:

Remove the syphon assembly.
To release the syphon from the sump connection, pull towards you (A).
Disconnect the discharge hose (B) at the plumbing manifold.
Remove the complete syphon assembly.

24.2

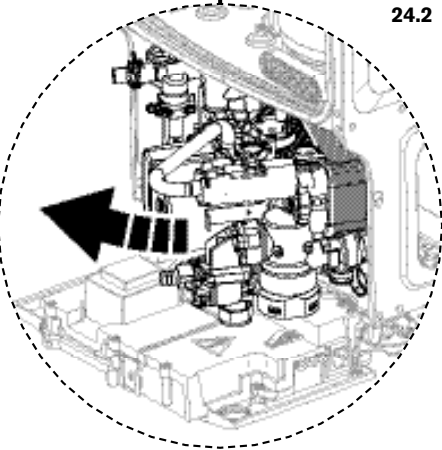
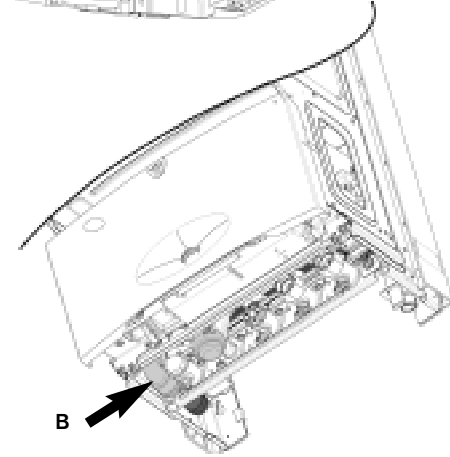

24. Hydraulic Block

- ▶ Ensure the appliance has been fully drained (see draining the appliance).
- ▶ Disconnect the electrical connections to the NTC, Turbine and pump.
- ▶ Undo the nuts securing the copper water pipes to the manifold (there is no need to remove the gas pipe)
- ▶ Release the spring clips securing these water pipes to the plastic housing and remove the pipes.
- ▶ Release the spring clip securing the expansion vessel pipe to the plastic housing and remove the pipe.
- ▶ Undo the nut securing the pressure gauge to its bracket and remove the gauge.
- ▶ Release the locking devices that secure the two copper water pipes leading to the combustion chamber by squeezing the two tabs together and rotating anticlockwise (viewed from above).
- ▶ Remove the rubber pipe connecting the sump and remove the syphon. **NOTE:** this is not essential but makes the removal of the block easier.

24.1 Undo the two screws securing the hydraulic block to the chassis (located top left / top right of the housing)

24.2 Lift the left hand side of the block slightly, then manoeuvre the block out, starting with the right hand side.

- ▶ Take care not to snag the harness or pressure gauge bracket.

NOTE: The block will still contain a small amount of water, which will spill if the block is tilted.

- ▶ To refit, follow the above in reverse. Ensure any seals that have been disturbed are renewed.

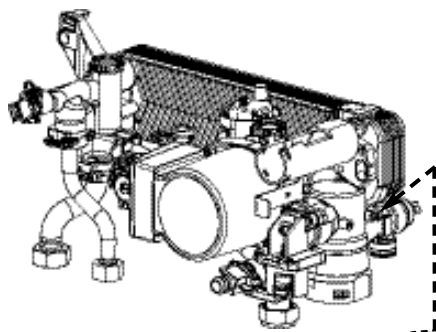
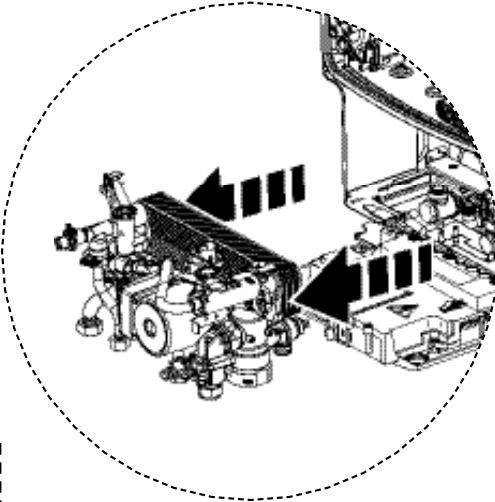

25.1

25.2

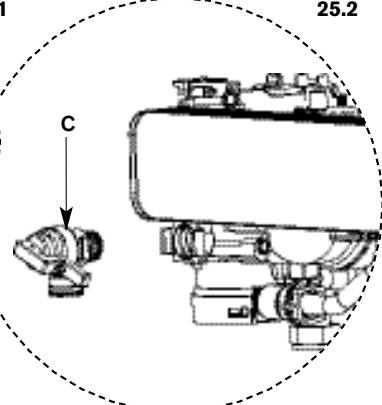
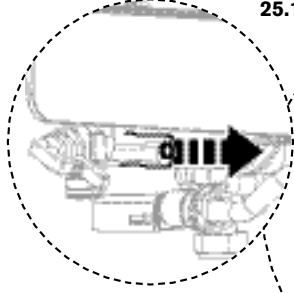

25. CH pressure relief valve

- ▶ Remove the hydraulic block from the boiler (See Removing the Hydraulic Block).

25.1 Remove the spring clip from the Pressure relief valve housing.

25.2 Withdraw the pressure release valve (A) from its housing.

- ▶ To refit, follow the above in reverse. Ensure any seals that have been disturbed are renewed.

SERVICING & SPARES

NOTE: Remove the Hydraulic block from the boiler (See removing the Hydraulic Block on page 51).

26. Plastic protection device

- ▶ Ensure the system is fully drained (see draining the appliance).
- ▶ Disconnect all pipes connected to the pump housing.
- ▶ Remove the electrical connection to the pump.
- ▶ Withdraw the metal clip to the right of the pump head to release the pump housing.
- ▶ Slide the device to the left and then withdraw it from the appliance.

26.1 Remove the spring clip from the pressure relief valve housing.

26.2 Withdraw the pressure relief valve (A).

- ▶ To refit, follow the above in reverse. Ensure any seals that have been disturbed are renewed.

27. DHW Heat exchanger

27.1 Undo the two screws (B) securing the plastic housings to the heat exchanger.

27.2 Remove the heat exchanger

- ▶ To refit, follow the above in reverse. Ensure any seals that have been disturbed are renewed.

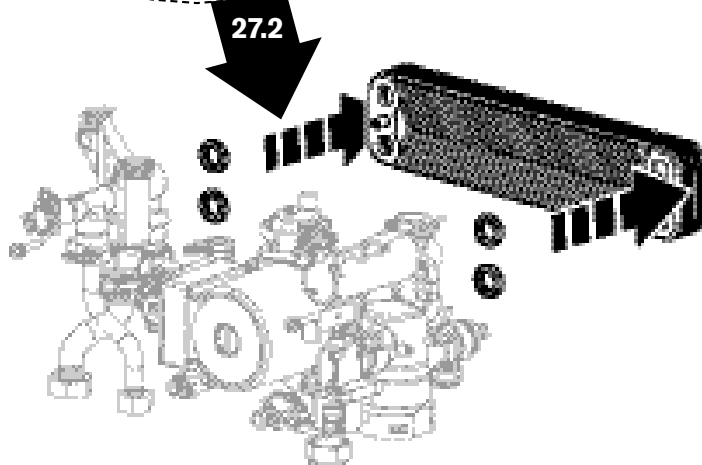
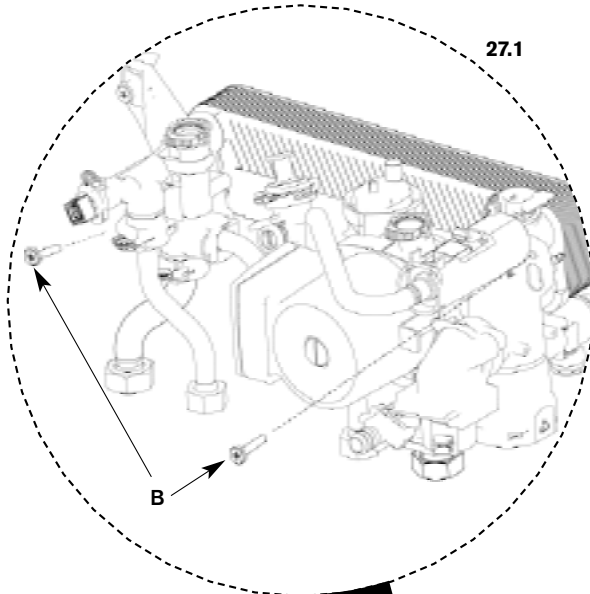
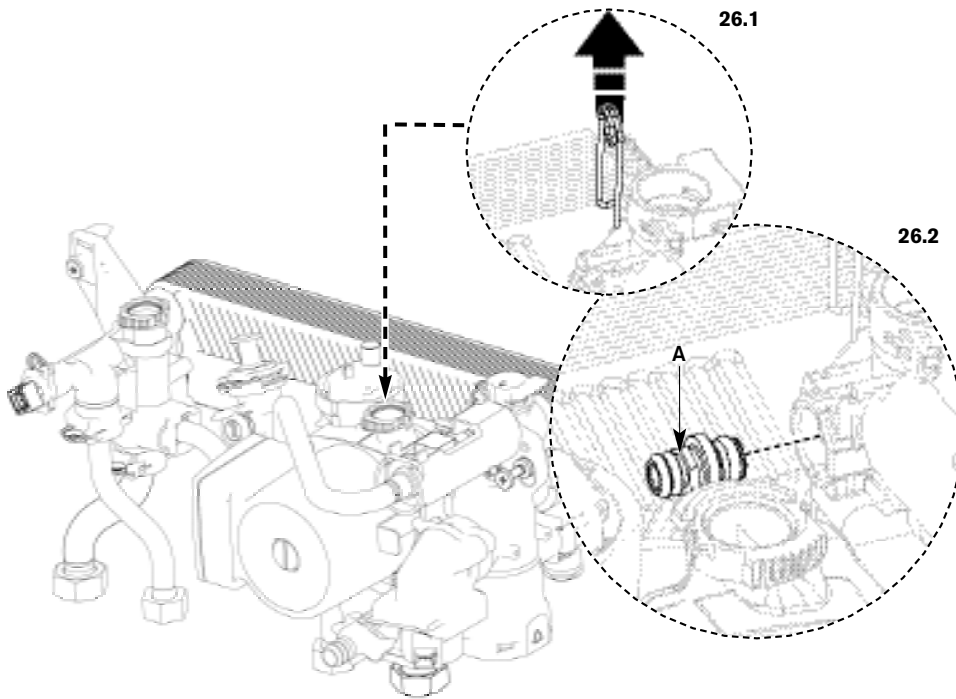

NOTE: Remove the Hydraulic block from the boiler (Refer to page 51).

28. Bypass valve

28.1 Remove the two spring clips at either end of the copper bypass pipe.

- ▶ Undo the screw securing the left hand plastic housing to the heat exchanger
- ▶ Move the housing to the left to free up the one end of the pipe.
- ▶ Remove the pipe from the right hand housing to reveal the bypass valve

28.2 Using a pair of pliers, pull out the bypass valve (A) from the housing

- ▶ To refit, follow the above in reverse. Ensure any seals renewed.

29. Expansion vessel

The expansion vessel can be replaced with the boiler in position if there is a side exit flue fitted and there is a minimum clearance of 340mm above the boiler casing. If vertical flue is fitted then a similar clearance to one side and the flue is required.

If clearance is not available, the boiler will need to be removed from the mounting frame to gain access to the expansion vessel.

Alternatively a second vessel of at least the capacity of 7lts can be fitted to the return from the heating system as close as possible to the boiler.

Expansion vessel replacement (Boiler in place)

- ▶ Isolate mains power from the boiler.
- ▶ Place the controls in service position.
- ▶ Isolate the boiler from the heating system (and cylinder return if internal diverter valve is fitted) using service valves.
- ▶ Drain boiler.

29.1 Remove clip from expansion vessel connection.

29.2 Remove screw retaining the vessel to the top of the boiler casing.

29.3 Pull the vessel up and out over the flue system or to one side if fitted with a vertical flue.

- ▶ Remove the flexible hose from the expansion vessel and fit to the replacement vessel using a new seal. Ensure that the connection to the boiler will be pointing to the right hand side of the appliance when fitted.
- ▶ Reassemble expansion vessel into boiler and connect flexible pipe to boiler.

Removing boiler

- ▶ Isolate electrical supply.
- ▶ Isolate system and gas connections at the service valves.
- ▶ Drain boiler.
- ▶ Disconnect electrical supply and any external controls.
- ▶ Disconnect flue connection from the boiler.
- ▶ Undo connection to boiler at the service valves.
- ▶ Remove clip from expansion vessel connection to the boiler.
- ▶ Gently raise the boiler off the mounting frame.
- ▶ Replace expansion vessel and refit the boiler to the mounting frame.
- ▶ Follow the commissioning procedure in this manual.

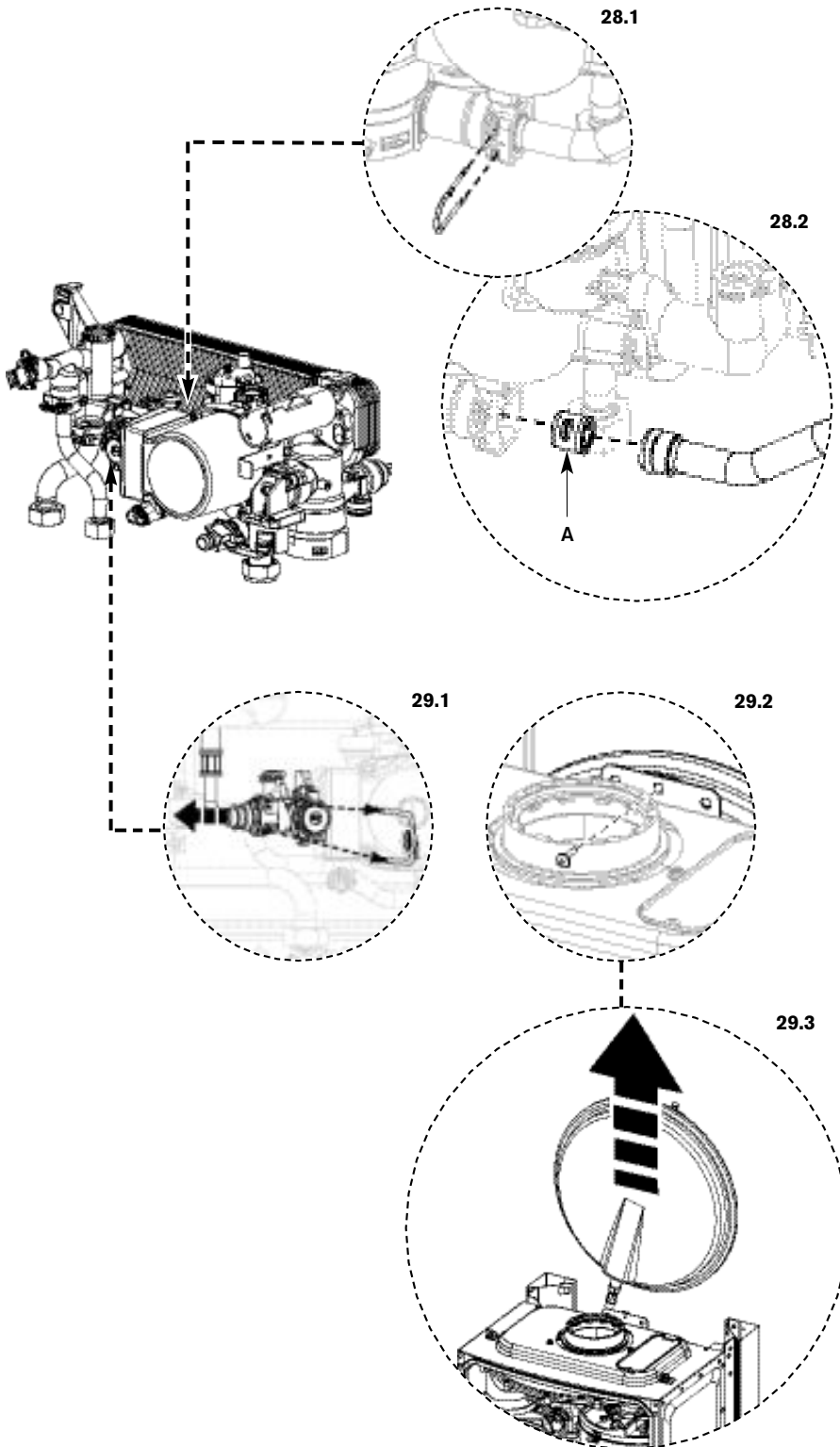

**THIS PAGE SHOWS THE SETTING PROCEDURE FOR THE SIT VALVE
FOR ALTERNATIVE VALVES SEE PAGE 55 FOR DUNGS.**

**SETTING THE GAS / AIR RATIO
FOR THE SIT 848.093 SIGMA**

THE SETTING OF THE GAS RATIO MUST BE CARRIED OUT BY A COMPETENT PERSON. SETTING OF THE GAS RATIO MUST **NOT** BE ATTEMPTED UNLESS THE PERSON CARRYING OUT THE CONVERSION IS EQUIPPED WITH A COMBUSTION ANALYSER CONFORMING TO BS 7927 AND IS COMPETENT IN ITS USE.

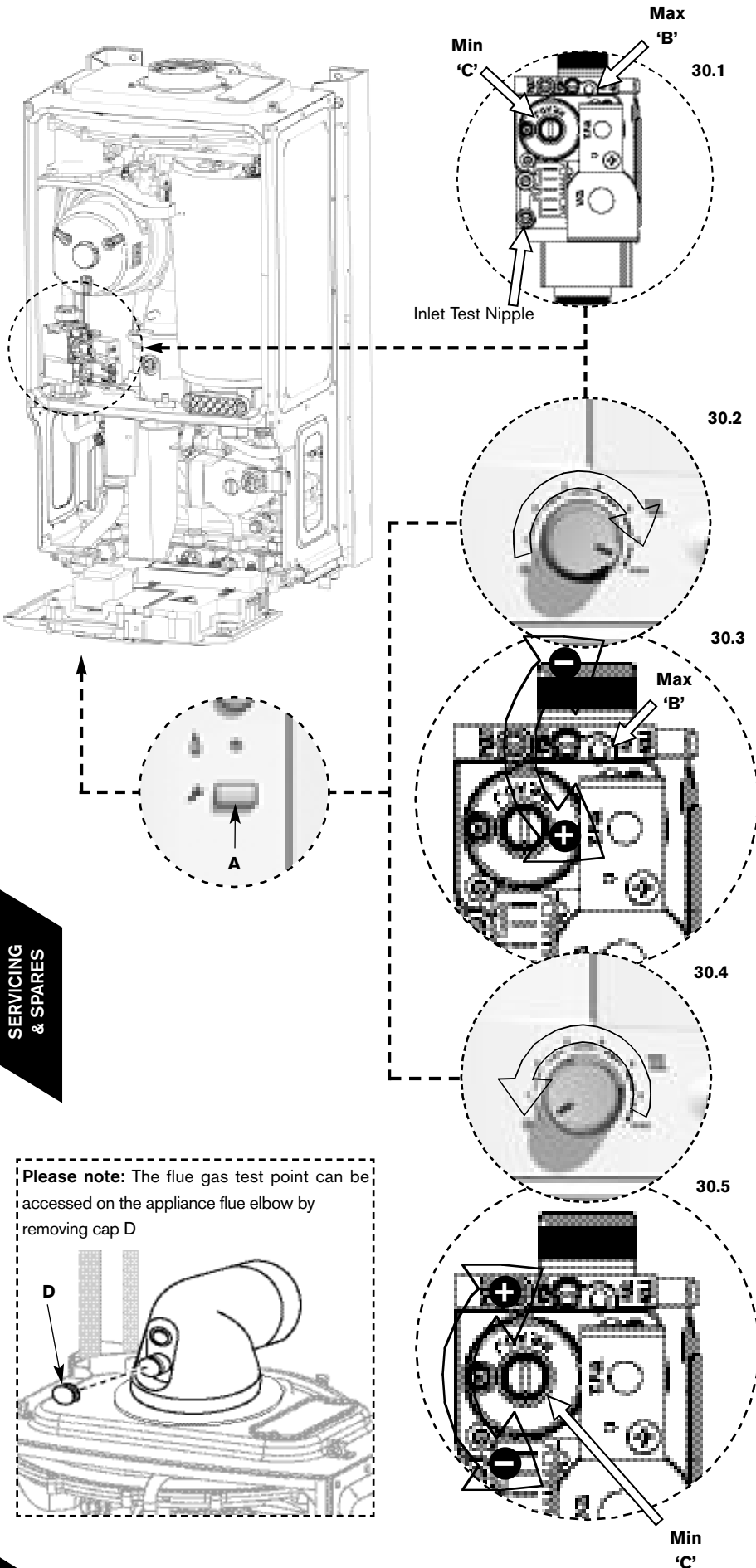

30. Setting the CO/CO₂

Note: When running in the service mode, the boiler will operate both the central heating & DHW circuits. This is to allow sufficient time for the setting procedure. It will be necessary to run sufficient water through the DHW circuit to ensure that the boiler will not cycle on low heating demands.

30.1 Connect manometer to inlet pressure point on the gas valve.

- ▶ To adjust the CO/CO₂ it will be necessary to first operate the boiler at maximum output.
- ▶ Press and hold down the service button (A) for 10 seconds until illuminated. The blue power indicator will flash.

30.2 Turn central heating control to maximum; the boiler will then go to maximum output.

NOTE: The control will resume normal operation after 15 minutes or if the service button is pressed for over a second.

30.3 Using a 2.5mm allen key set the CO₂ via adjuster (B) using the table below.

CO/CO₂ settings for Greenstar i Junior

NOTE. CO/CO₂ should be measured after 10 minutes

Gas type	CO ₂ setting maximum	CO ₂ setting minimum
Natural gas	9.8% ± 0.5%	9.2% ± 0.5%
LPG	11.0% ± 0.5%	10.5% ± 0.5%
CO - less than 200ppm (0.002 ratio)		

- ▶ Check CO is less than 200ppm.
 - ▶ Measure the inlet pressure; it should be no less than 18.5mb for NG or 37mb for LPG.
- 30.4** Set the central heating control to minimum. The boiler will go to minimum power.

30.5 Measure the CO/CO₂ and check against the table above. If required adjust (C) on the gas valve until the correct measurement is set.

- ▶ Remove brass dust cap with flat bladed screw driver. Then using a 4mm allen key adjust CO/CO₂. Replace dust cap.
- ▶ Check that the CO is less than 200ppm.
- ▶ Return to maximum and re-check the CO/CO₂. If correct press and hold down the service button for 2 seconds; the button will cease to be illuminated and the blue power indicator will be permanently illuminated.
- ▶ Remove manometer and re-seal inlet pressure point on gas valve.
- ▶ Re-assemble and refit boiler case.

SERVICING & SPARES

Please note: The flue gas test point can be accessed on the appliance flue elbow by removing cap D

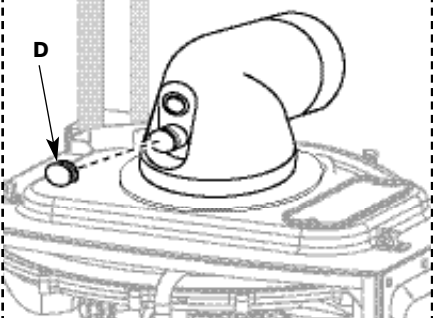

THE SETTING OF THE GAS RATIO MUST BE CARRIED OUT BY A COMPETENT PERSON. SETTING OF THE GAS RATIO MUST NOT BE ATTEMPTED UNLESS THE PERSON CARRYING OUT THE CONVERSION IS EQUIPPED WITH A COMBUSTION ANALYSER CONFORMING TO BS 7927 AND IS COMPETENT IN ITS USE.

30. Setting the CO/CO₂

Note: When running in the service mode, the boiler will operate both the central heating & DHW circuits. This is to allow sufficient time for the setting procedure. It will be necessary to run sufficient water through the DHW circuit to ensure that the boiler will not cycle on low heating demands.

30.1 Connect manometer to inlet pressure point on the gas valve.

- ▶ To adjust the CO/CO₂ it will be necessary to first operate the boiler at maximum output.
- ▶ Press and hold down the service button (A) for 10 seconds until illuminated. The blue power indicator will flash.

30.2 Turn central heating control to maximum; the boiler will then go to maximum output.

NOTE: The control will resume normal operation after 15 minutes or if the service button is pressed for over a second.

30.3 Using a 2mm hexagonal ball driver set the CO/CO₂ via adjuster (B) using table below.

CO/CO₂ settings for Greenstar i Junior

NOTE. CO/CO₂ should be measured after 10 minutes

Gas type	CO ₂ setting maximum	CO ₂ setting minimum
Natural gas	9.8% ± 0.5%	9.2% ± 0.5%
LPG	11.0% ± 0.5%	10.5% ± 0.5%
CO - less than 200ppm (0.002 ratio)		

- ▶ Check CO is less than 200ppm.
- ▶ Measure the inlet pressure; it should be no less than 37mb for LPG.

30.4 Set the central heating control to minimum. The boiler will go to minimum power.

30.5 Measure the CO/CO₂ and check against the table above. If required adjust (C) on the gas valve, using a 2mm hexagonal ball driver, until the correct measurement is set.

- ▶ Check CO is less than 200ppm
- ▶ Return to maximum and re-check the CO/CO₂. If correct press and hold down the service button for 2 seconds; the button will cease to be illuminated and the blue power indicator will be permanently illuminated.
- ▶ Remove manometer and re-seal inlet pressure point on gas valve.
- ▶ Re-assemble and refit boiler case.

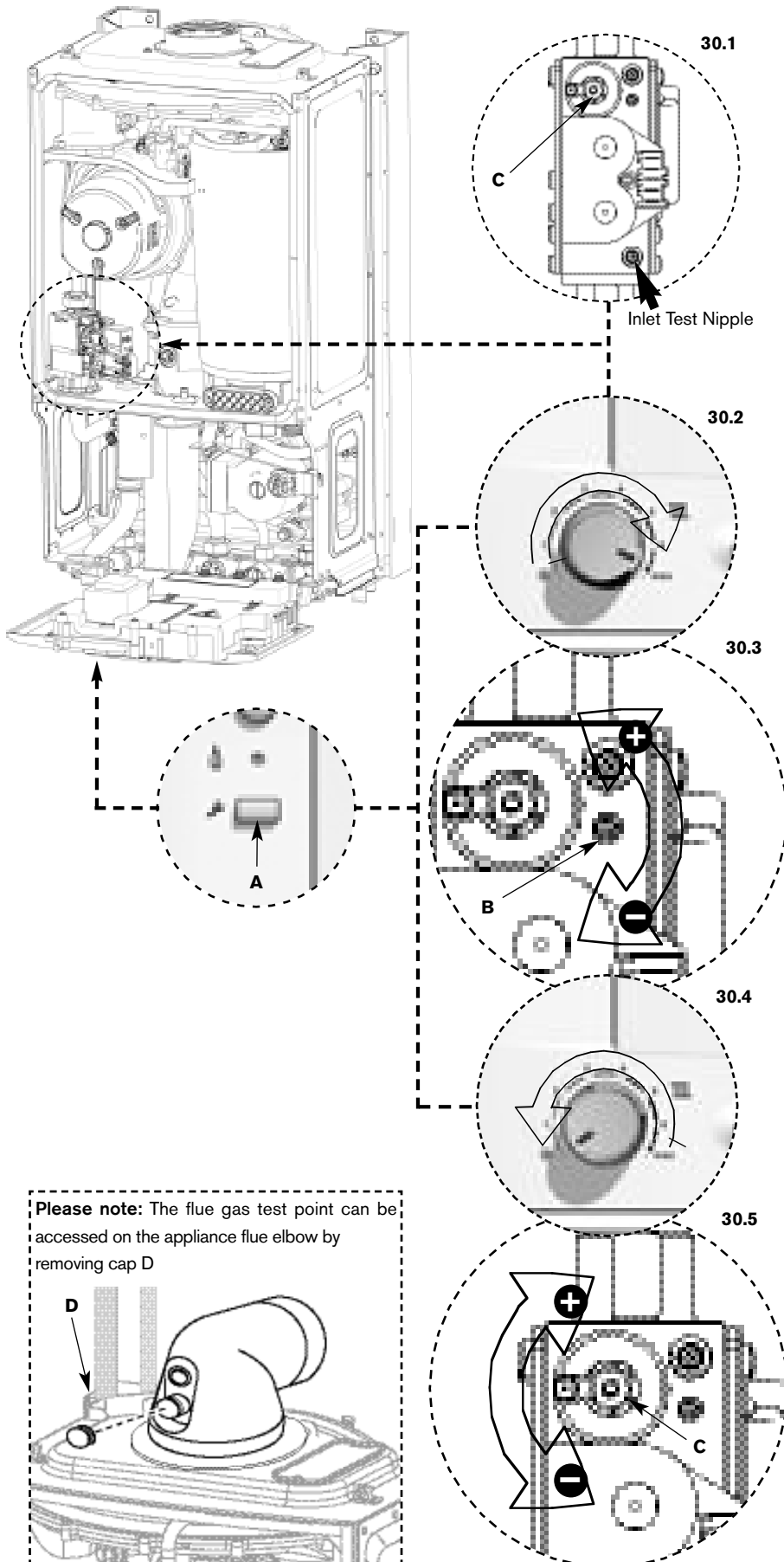

Please note: The flue gas test point can be accessed on the appliance flue elbow by removing cap D

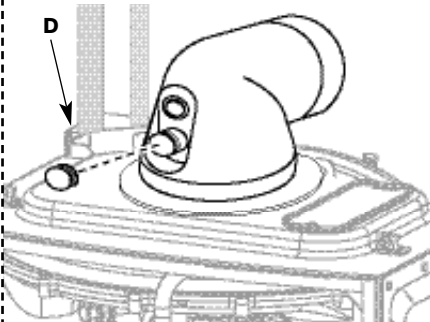

SERVICING & SPARES

SHORT PARTS LIST

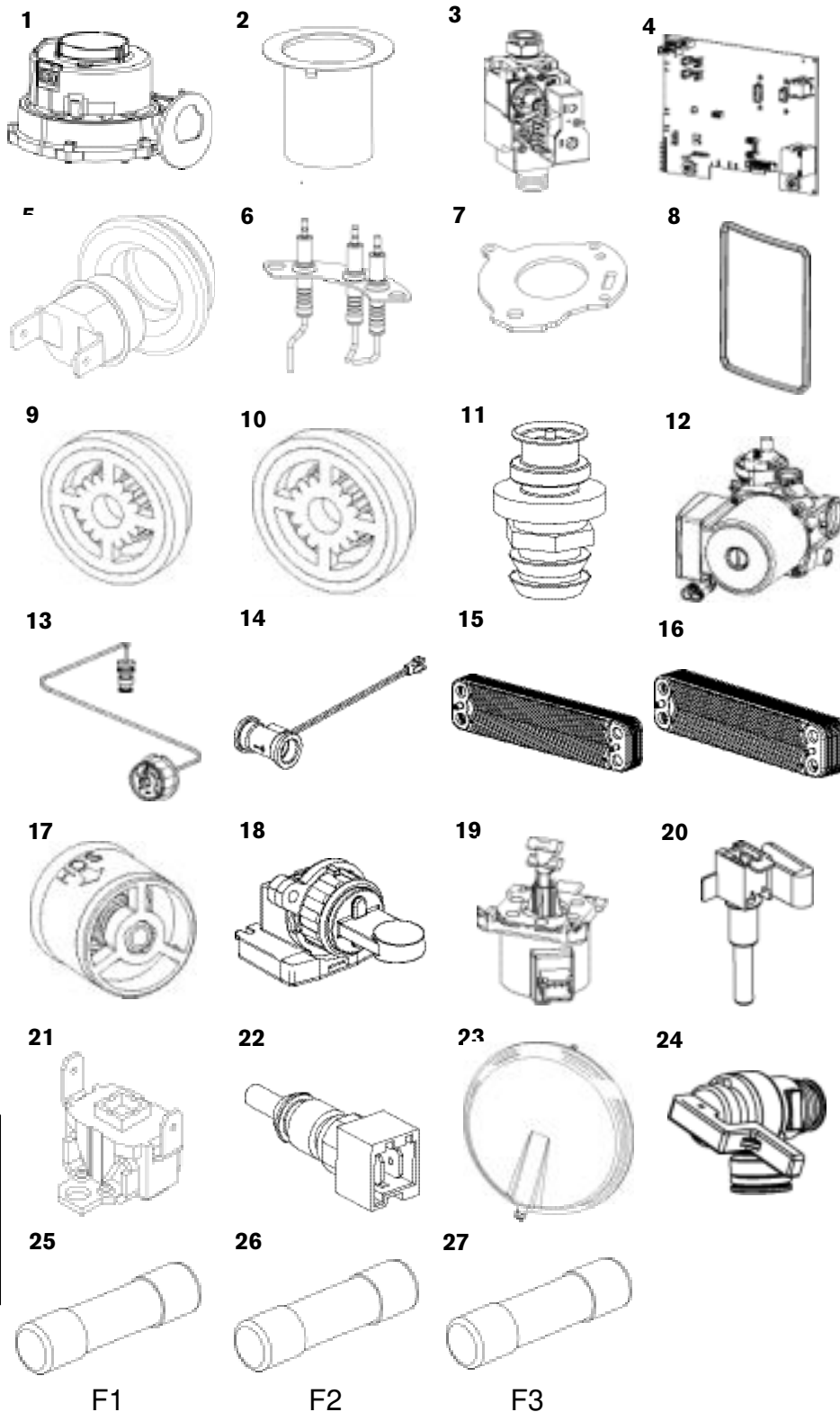

1 Fan WORCESTER Part No. GC No.	8 717 204 453 0 H26 536
2 Burner WORCESTER Part No. GC No.	8 718 120 609 0 H26 538
3 Gas valve NG WORCESTER Part No. GC No. NG WORCESTER Part No. GC No. LPG WORCESTER Part No. GC No.	8 716 107 052 0 H26 540 8 716 107 053 0 H26 539
4 Control board WORCESTER Part No. GC No.	8 716 109 539 0 H28 966
5 Flue overheat thermostat (Grommet type) WORCESTER Part No.	8 717 206 213 0
6 Electrodes WORCESTER Part No. GC No.	8 718 107 087 0 H26 544
7 Gasket - burner/electrodes WORCESTER Part No. GC No.	8 716 106 506 0 H26 545
8 Seal - inner case/mantel WORCESTER Part No. GC No.	8 716 106 635 0 H26 546
9 Flow reg. Type E 8 litre WORCESTER Part No. GC No.	8 716 141 143 0 379 215
10 Flow reg. Type E 10 litre WORCESTER Part No. GC No.	8 716 107 044 0 394 291
11 Pressure relief valve DHW WORCESTER Part No. GC No.	8 717 401 029 0 H02 526
12 Pump assembly 3 speed WORCESTER Part No. GC No.	8 716 106 355 0 H02 527
13 Pressure gauge WORCESTER Part No. GC No.	8 717 208 107 0 H02 528
14 Flow sensor WORCESTER Part No. GC No.	8 716 107 223 0 H02 529
15 Heat exchanger 12 plate WORCESTER Part No. GC No.	8 716 106 686 0 H02 538
16 Heat exchanger 16 plate WORCESTER Part No. GC No.	8 716 106 685 0 H02 531
17 By-pass valve WORCESTER Part No. GC No.	8 716 106 434 0 H02 532
18 Diverter valve assembly WORCESTER Part No. GC No.	8 716 106 845 0 H02 533
19 Diverter valve motor WORCESTER Part No. GC No.	8 716 106 847 0 H02 534
20 Control sensor - primary WORCESTER Part No. GC No.	8 716 106 688 0 H26 542
21 High limit stat WORCESTER Part No. GC No.	8 707 206 196 0 H26 584
22 DHW temperature sensor WORCESTER Part No. GC No.	8 714 500 081 0 H02 538
23 Expansion vessel WORCESTER Part No. GC No.	8 716 105 545 0 H05 206
24 Pressure relief valve WORCESTER Part No. GC No.	8 716 106 431 0 H09 750
25 Fuse 2.5 Amp F1 WORCESTER Part No. GC No.	1 904 521 342 0 378 315
26 Fuse 1.6 Amp F2 WORCESTER Part No. GC No.	1 904 522 740 0 E27 305
27 Fuse 0.5 Amp F3 WORCESTER Part No. GC No.	1 904 522 730 0 E27 300

ISOLATE MAINS ELECTRICAL SUPPLY AND REMOVE OUTER CASE AS SHOWN IN THE INSTALLATION, COMMISSIONING & SERVICING INSTRUCTIONS

THE CONVERSION MUST BE CARRIED OUT BY A COMPETENT PERSON. IT MUST **NOT** BE ATTEMPTED UNLESS THE PERSON CARRYING OUT THE CONVERSION IS EQUIPPED WITH A COMBUSTION ANALYSER CONFORMING TO BS 7927 AND IS COMPETENT IN ITS USE.

Important: The appliance shall not be installed into a room or internal space below ground level when it is intended for use with LPG (propane - G31). This does not preclude the installation into a room or space which is a basement on one side of the building but open to ground on the opposite side.

Installation Regulations

In addition to those specified in the main booklet the following standard applies when converting to an LPG appliance: **BS 5842 Domestic Propane Gas Burning Installations.**

All conversions will require the air gas ratio to be set correctly for the gas used. The procedure for setting the air gas ratio is at the rear of these instructions.

1. Moving boiler control to service position

- ▶ Remove boiler case, as described on page 36.
- 1.1 Remove screw (A) from retaining bracket.
- 1.2 Lower control panel into service position.

2. Gas valve

- ▶ Isolate gas supply at boiler gas cock.
- 2.1 Remove wire clip from gas valve outlet then pull valve outlet elbow free from gas valve.
- 2.2 Undo bottom gas connection to gas valve.
- 2.3 Undo two securing screws (B) on the underside of casing.
 - ▶ Pull valve up and forward out of boiler.
 - ▶ Disconnect electrical connections.
 - ▶ Fit plastic retaining nut to the outlet of the gas valve from the kit and hand tighten.
 - ▶ Replace valve with new seals.
 - ▶ Check for gas soundness.

3. Code plug

- 3.1 Remove 3 screws (C) retaining plastic cover at rear of control box and remove.
- 3.2 Replace code plug (D) with new one supplied with conversion kit.
 - ▶ Replace plastic cover.
 - ▶ Place control in normal position and secure with screw.

THE AIR / GAS RATIO MUST BE RESET AFTER CONVERSION. THE PROCEDURE CAN BE FOUND IN SETTING THE AIR/GAS RATIO SECTION OF THIS MANUAL.

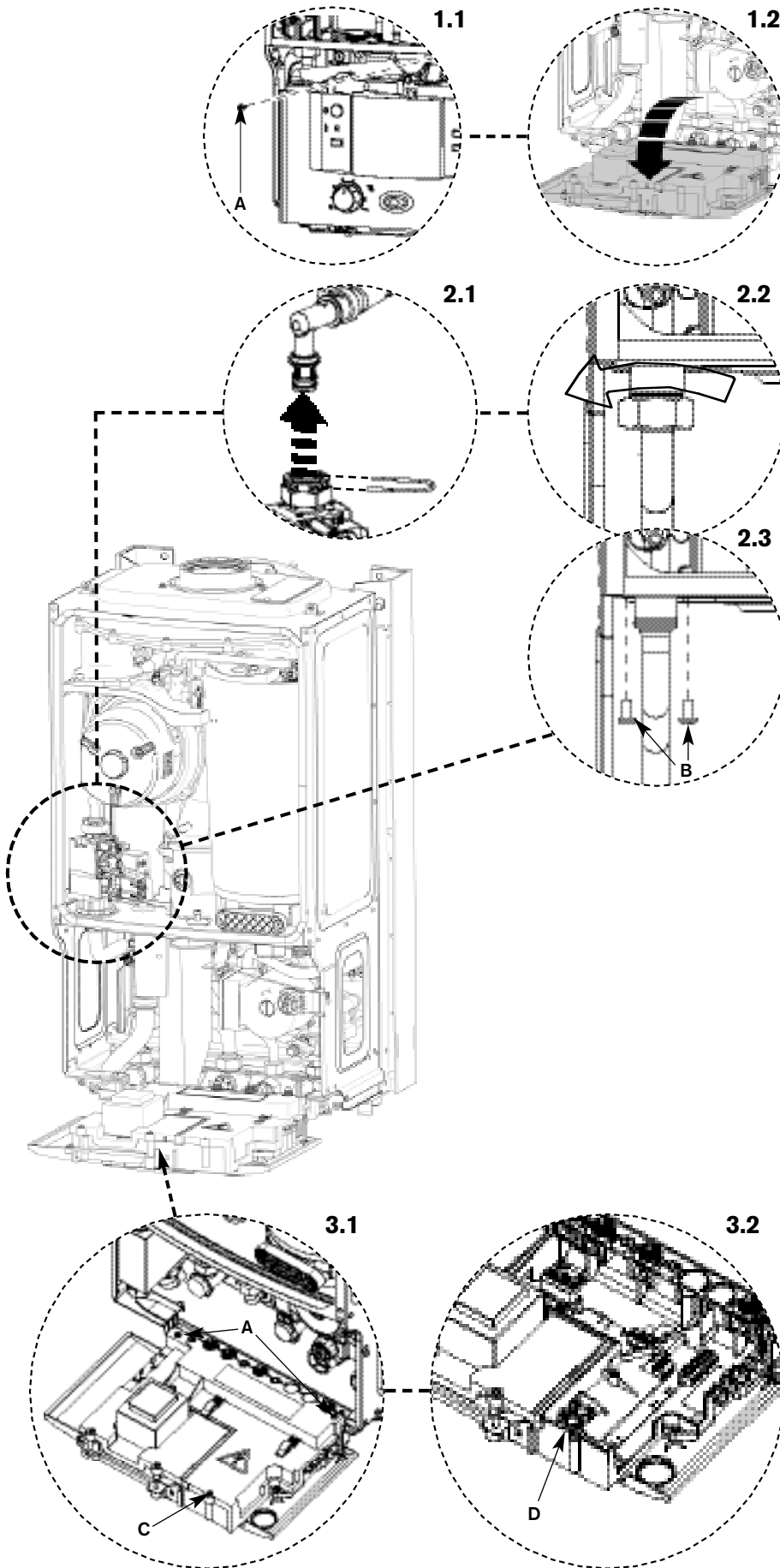

Code plugs	
24kW NG	- 100
24kW LPG	- 101
28kW NG	- 102
28kW LPG	- 103

CONVERSION KITS

NOTE : This fault finding information is for guidance only. Worcester cannot be held responsible for costs incurred by persons not deemed to be competent.

The electronic control system for this boiler incorporates a blue central indicator. This normally confirms the permanent mains supply but, by flashing at different rates during a fault, provides a guide to the cause as listed.

This fault finding system assumes that the appliance has been operating normally until the time of failure (i.e. not a first installation error).

PRELIMINARY CHECKS : Preliminary electrical system checks are the first electrical checks to be carried out during a fault-finding procedure. On completion of the Service/Fault-Finding task which has required the breaking and remaking of electrical connections, check (a) EARTH CONTINUITY, (b) SHORT CIRCUIT CHECK, (c) POLARITY and (d) RESISTANCE TO EARTH.

Blue light indication	Lockout reset button	Fault	Possible solution/check
Off	Off	No power at control board	Permanent mains supply to boiler. Boiler mains switch. Fuse F1, 2.5A or Fuse F3, 0.5A Transformer (both coils below 100Ω). Otherwise replace control board.
On	Off	Boiler not operating during central heating demand (HW ok)	Live demand at ST10-LR (from external roomstat/timer). Facia mounted timer (if fitted). CH knob in winter position. Diverter valve. Control board.
		Boiler operating without live demand at ST10-LR (from external roomstat timer).	Some older thermostats (containing capacitors) may give a low voltage return at ST10-LR when the thermostat contacts are open. Check that there is not a permanent live at ST10-LR from another source.
		Boiler not operating during hot water demand (CH ok).	See Flow Sensor Test below. or Diverter valve. Control board.
		Boiler not operating during any demand.	Fan. Control board.
Slow flash (normally off, flashes on)	Flashing (reset required)	Ignition lockout	Gas present and at correct pressure. Combustion CO ₂ level. Flue condition. Ignition electrodes / harness / connections. Gas valve (coils 140-190Ω) / low voltage harness connection. Otherwise replace control board.
Slow flash (normally on, flashes off)	Flashing (reset required)	Flue overheat	Heat exchanger blocked. Heat exchanger baffles removed and not refitted.
		Heat exchanger overheat	Water pressure. All air vented. Pump / harness / connections. Water leaks / blockages. Safety thermostats / low voltage wiring harness / connections. Otherwise replace control board.
		Flue blockage	Blockage in flue system.
Fast flash	Off	Volatile lockout	Temperature sensor (8000-20,000Ω). Low voltage wiring harness / connections to sensor. Fan / fan harness / connections to fan. Code plug fitted.
Fast flash	Flashing	Internal fault	Replace control board
2 pulses	No light	Not a fault code	Service mode selected to min, press service button to return to normal.
5 pulses	No light	Not a fault code	Service mode selected to max, press service button to return to normal.

Flow Sensor Test

:Replace control board if: 5V is not across the red and black cables.
:1.5V-3.5V is across the yellow and black cables (with water flowing).
Otherwise replace flow sensor.

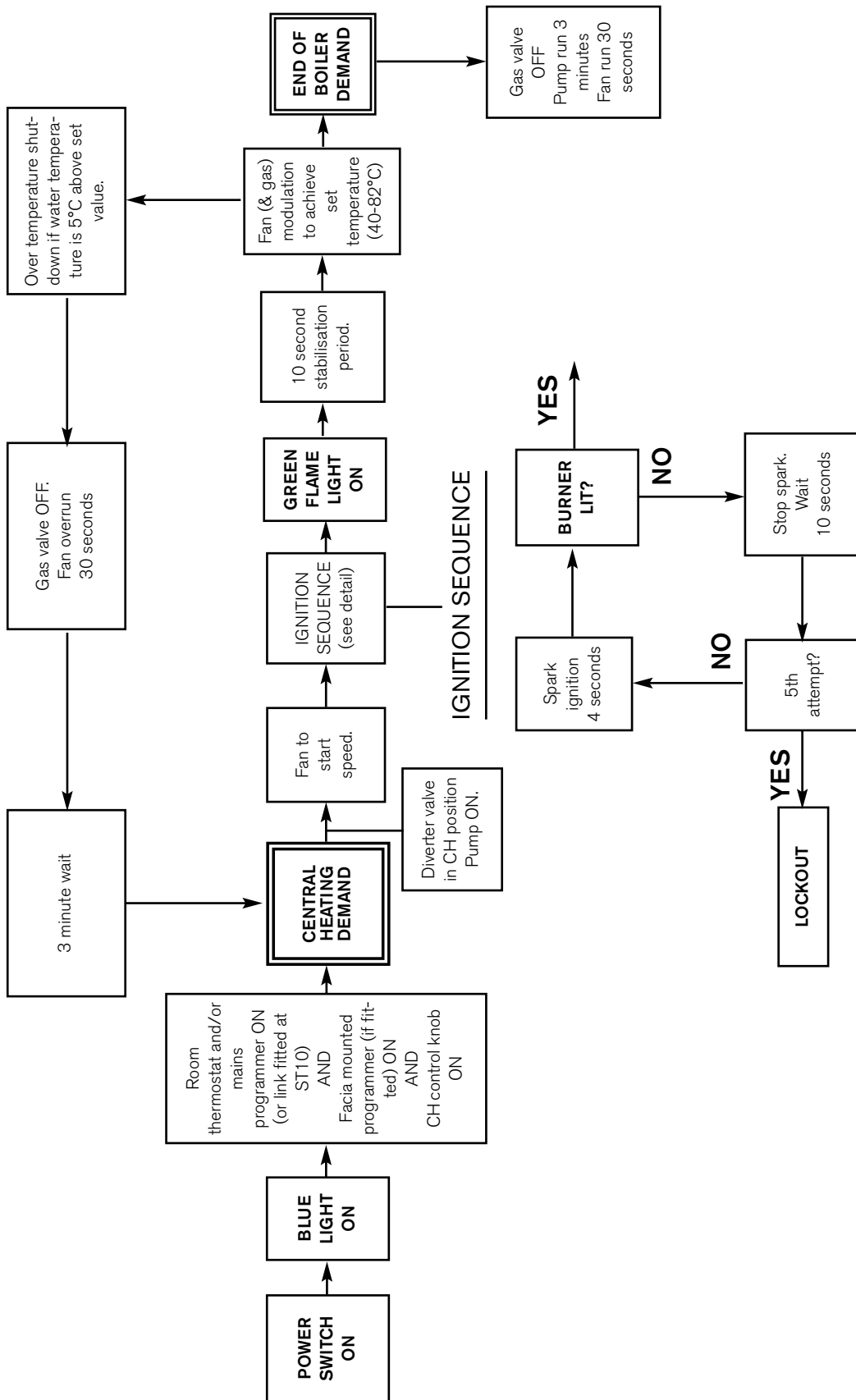

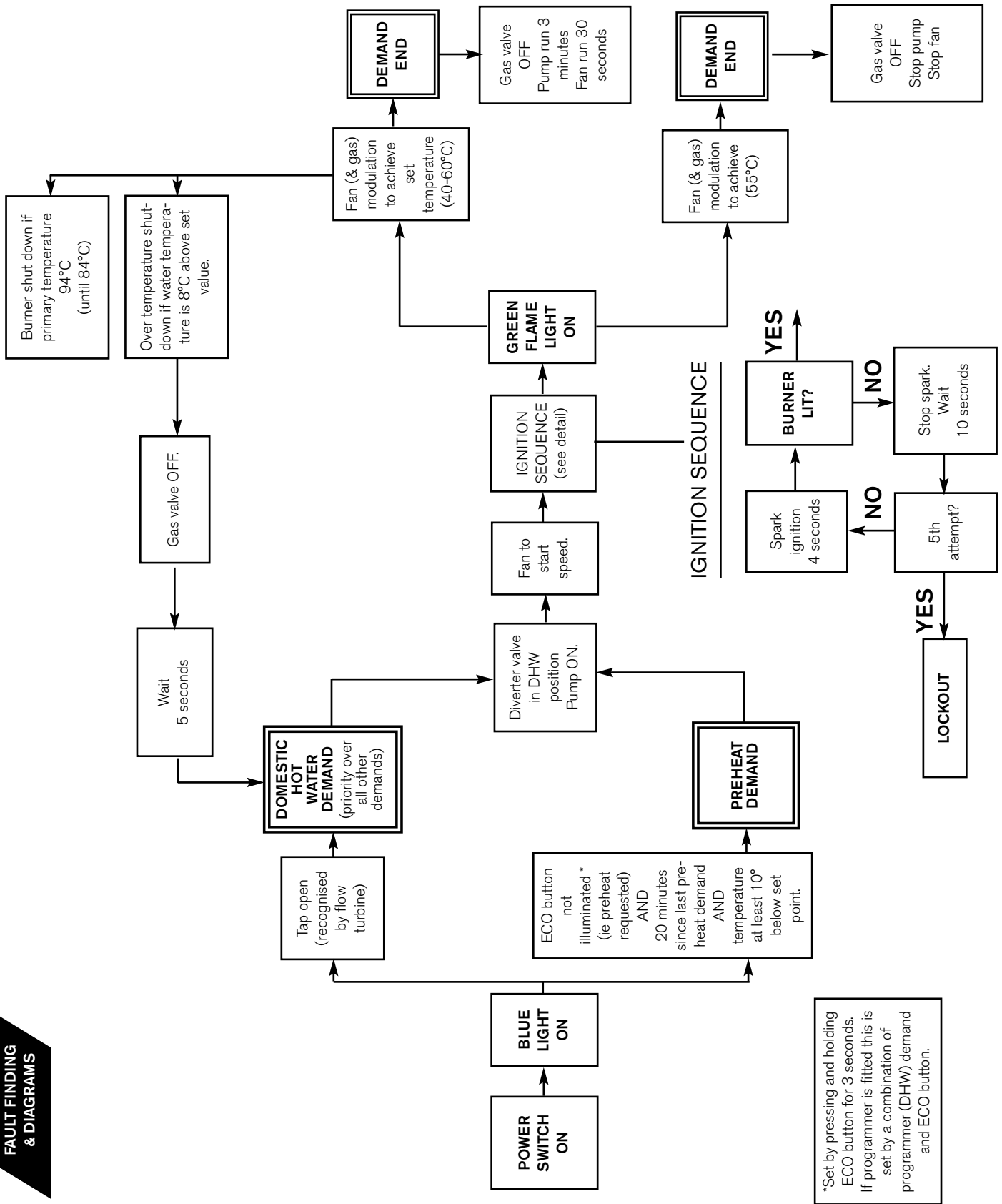

*Set by pressing and holding ECO button for 3 seconds. If programmer is fitted this is set by a combination of programmer (DHW) demand and ECO button.

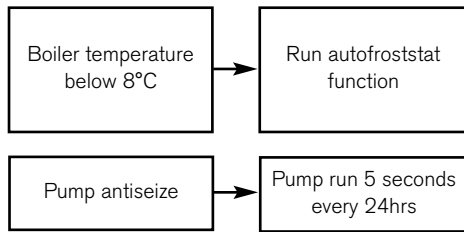

SERVICE RECORD

It is recommended that your heating system is serviced regularly and that the appropriate Service Record is completed.

Service Provider

Before completing the appropriate Service Record below, please ensure you have carried out the service as described in the manufacturer's instructions.

Always use the manufacturer's specified spare part when replacing controls.

SERVICE 1 Date

Energy Efficiency Checklist completed? Yes No

Engineer Name _____

Company Name _____

Telephone Number _____

CORGI ID Number _____

Comments _____

Signature _____

SERVICE 2 Date

Energy Efficiency Checklist completed? Yes No

Engineer Name _____

Company Name _____

Telephone Number _____

CORGI ID Number _____

Comments _____

Signature _____

SERVICE 3 Date

Energy Efficiency Checklist completed? Yes No

Engineer Name _____

Company Name _____

Telephone Number _____

CORGI ID Number _____

Comments _____

Signature _____

SERVICE 4 Date

Energy Efficiency Checklist completed? Yes No

Engineer Name _____

Company Name _____

Telephone Number _____

CORGI ID Number _____

Comments _____

Signature _____

SERVICE 5 Date

Energy Efficiency Checklist completed? Yes No

Engineer Name _____

Company Name _____

Telephone Number _____

CORGI ID Number _____

Comments _____

Signature _____

SERVICE 6 Date

Energy Efficiency Checklist completed? Yes No

Engineer Name _____

Company Name _____

Telephone Number _____

CORGI ID Number _____

Comments _____

Signature _____

SERVICE 7 Date

Energy Efficiency Checklist completed? Yes No

Engineer Name _____

Company Name _____

Telephone Number _____

CORGI ID Number _____

Comments _____

Signature _____

SERVICE 8 Date

Energy Efficiency Checklist completed? Yes No

Engineer Name _____

Company Name _____

Telephone Number _____

CORGI ID Number _____

Comments _____

Signature _____

SERVICE 9 Date

Energy Efficiency Checklist completed? Yes No

Engineer Name _____

Company Name _____

Telephone Number _____

CORGI ID Number _____

Comments _____

Signature _____

SERVICE 10 Date

Energy Efficiency Checklist completed? Yes No

Engineer Name _____

Company Name _____

Telephone Number _____

CORGI ID Number _____

Comments _____

Signature _____

If in the unlikely event the boiler does not give complete satisfaction, before calling for a service engineer, the installer should check the following:-

No Central Heating

Is the room stat correctly wired up at the boiler and the room thermostat?

Refit the link between Ls and LR on terminal block ST 10. If the boiler functions correctly, the problem may be with the external thermostat or the wiring of it.

No Hot water

Are the domestic hot and cold pipes crossed?

Check 1: If the boiler has a built in filling loop.

1. Close the 15mm cold inlet bulkhead valve with a screwdriver.
2. Open a hot tap (no water should flow from the open tap).
3. Insert filling key into filling link.
4. Open valve to fill system.

If it is still possible to re-pressurise the sealed system, the domestic hot and cold pipes are crossed.

Check 2: If the boiler has an external filling loop fitted to the cold main adjacent to the boiler.

1. Close the 15mm cold inlet bulkhead valve with a screwdriver.
2. Open a hot tap (no water should flow from the open tap).
3. Connect flexible hose across filling link.
4. Open valve to fill system.

If no water enters the sealed system, the domestic hot and cold pipes are crossed.

Burner lights then goes out in DHW or CH mode

Does the boiler run normally with the front cover off and then fail when the cover is put back on?

If yes there is likely to be a flue problem - either the air inlet is blocked or the inner flue is leaking flue gases into the air inlet.

General checks

1. Is all the air bled from the gas supply?
2. Is all the air bled from the primary water system?
3. Is there 230v ac across the boiler live and neutral terminals?
(L & N on ST10)
4. Is the polarity correct?
5. Is the incoming gas pressure at least 18mbar with the boiler at maximum output?



8716115162

Pack Number



8716115166

CONTACT INFORMATION

WORCESTER, BOSCH GROUP:

TECHNICAL:	08705 266241
SERVICE:	08457 256206
SPARES:	01905 752571
LITERATURE:	01905 752556
TRAINING:	01905 752526
SALES:	01905 752640
WEBSITE:	www.worcester-bosch.co.uk

Dedicated to heating comfort

Worcester, Bosch Group

Cotswold Way, Warndon, Worcester WR4 9SW.

Tel. 01905 754624 Fax. 01905 754619

Worcester, Bosch Group is a brand name of Bosch Thermotechnology Ltd.

www.worcester-bosch.co.uk

8 716 115 166a (06/2008)

