

INSTALLATION, COMMISSIONING AND SERVICING INSTRUCTIONS

WALL HUNG RSF GAS FIRED CONDENSING COMBINATION BOILER

GREENSTAR 24/28/30

FOR SEALED CENTRAL HEATING SYSTEMS AND MAINS FED DOMESTIC HOT WATER



The appliance is for use with Natural Gas
(Cat I 2H type C₁₃, C₃₃ & C₅₃)

	Model	GC Number
Natural Gas	24 kW	47-406-54
	28 kW	47-406-56
	30 kW	47-406-64

CONTENTS

1	Key to symbols and safety instructions	3	6.1	Pre-commissioning checks	28
1.1	Explanation of symbols	3	6.2	Filling the system	28
1.2	Safety precautions	4	6.3	Water treatment	28
2	Appliance information	5	6.4	Starting the appliance	29
2.1	Standard package	5	6.5	Switching the appliance on/off	30
2.2	Boiler Features	5	6.6	Starting the central heating	30
2.3	Technical data	6	6.7	Setting Low NOx heating output	30
2.4	Appliance layout	7	6.8	Heating control	30
3	Pre-Installation	8	6.9	CO and Combustion checks	31
3.1	Cleaning primary systems	8	6.10	Finishing commissioning	31
3.2	Mains supply	8	6.11	Setting the DHW temperature	32
3.2.1	Electrical supply	8	6.12	Summer mode (central heating off, DHW only)	32
3.2.2	Gas supply	8	6.13	Frost protection	32
3.2.3	Water supply	8	6.14	Button lock	33
3.3	Water systems and pipe work	9	7	Setting the control panel	33
3.4	Condensate pipe work	10	7.1	General	33
3.4.1	Internal connections	10	7.2	Service functions overview	34
3.4.2	External connections	11	7.2.1	Service level 1	34
3.5	Pressure relief pipe work	12	7.2.2	Service level 2	34
3.6	Boiler location and clearances	13	7.3	Description of service functions	35
3.6.1	Installation	13	7.3.1	Service level 1	35
3.6.2	Installation and servicing clearances - unventilated compartments	13	7.3.2	Service level 2	37
3.6.3	Compartments	13	8	Service	38
3.6.4	Bathrooms	13	8.1	Checking the gas supply pressure	38
3.7	Flue options	13	8.2	Check flue integrity	38
3.8	Flue terminal positions	16	8.3	Checking flue system for tightness	38
3.9	Plume management terminal positions	17	8.4	Measuring CO content of flue gas	39
4	Installation	18	8.5	Setting gas/air ratio (CO ₂)	39
4.1	Unpacking	18	8.6	Fan pressure test	40
4.2	Wall mounting template & flue opening	19	9	Environmental protection	40
4.3	Pre-plumbing the boiler connections	20	10	Inspection/Maintenance	40
4.4	Hanging the boiler	20	10.1	Description of various maintenance operations	41
4.5	Flue installation	21	10.1.1	Draining the boiler	41
4.5.1	Measuring the flue (standard flue):	22	10.1.2	Checking heat exchanger, burner and electrodes	41
4.5.2	Reducing the telescopic flue length:	22	10.1.3	Filter in cold water pipe	43
4.5.3	Installing the telescopic flue:	22	10.1.4	Plate heat exchanger	43
4.5.4	Flue terminal plume re-direction:	23	10.1.5	Gas valve	44
5	Electrical	24	10.1.6	3-way diverter valve	44
5.1	General	24	10.1.7	Replacing the diverter valve motor	44
5.2	Mains power connection	24	10.1.8	Pump and return manifold	44
5.2.1	New complete system installations	24	10.1.9	Cleaning condensate trap	45
5.2.2	Existing installations	24	10.1.10	Diaphragm in mixer unit	45
5.3	Access to electrical connections	24	10.1.11	Checking the expansion vessel	45
5.3.1	Mounting optional plug-in controls	25	10.1.12	Changing the expansion vessel	45
5.3.2	New complete system installations	25	10.1.13	Setting the heating system pressure	45
5.3.3	Existing installations	26	10.1.14	Checking wiring	46
5.4	Electrical wiring diagram	27	10.1.15	Cleaning of other components	46
6	Commissioning	28	10.2	Short parts list	46

11	Displays	47
12	Fault finding	48
12.1	Troubleshooting	48
12.2	Faults that are displayed	48
12.3	Faults that are not displayed	49
12.4	Sensor values	49
12.4.1	Flow temperature sensor	49
12.4.2	DHW temperature sensor	49
12.5	Code plug	49

1 KEY TO SYMBOLS AND SAFETY INSTRUCTIONS

1.1 EXPLANATION OF SYMBOLS

WARNING SYMBOLS

	Safety instructions in this document are framed and identified by a warning triangle which is printed on a grey background.
---	---

Signal words indicate the seriousness of the hazard in terms of the consequences of not following the safety instructions.

- **NOTICE** indicates possible damage to property or equipment, but where there is no risk of injury.
- **CAUTION** indicates possible injury.
- **WARNING** indicates possible severe injury.
- **DANGER** indicates possible risk to life.

IMPORTANT INFORMATION

	Notes contain important information in cases where there is no risk of personal injury or material losses and are identified by the symbol shown on the left. They are bordered by horizontal lines above and below the text.
---	---

ADDITIONAL SYMBOLS

Symbol	Meaning
1.	a numbered step in an action sequence
▶	a step in an action sequence
①	a reference number to identify or refer to a part or item
•	a list entry
–	a list entry (second level)

Table 1 Symbols

SYMBOLS USED IN THIS MANUAL







	Domestic Hot Water
	Central Heating
	Hot Water Storage Cylinder
	Domestic Cold Water Supply
	Electrical Supply
	Gas Supply

Table 2 Commonly used symbols

PLEASE READ THESE INSTRUCTIONS CAREFULLY BEFORE STARTING INSTALLATION.

These instructions are applicable to the Worcester appliance model(s) stated on the front cover of this manual only and must not be used with any other make or model of appliance.

These instructions apply in the UK and Ireland only and must be followed except for any statutory obligations.

This appliance must be installed by a **GAS SAFE** registered, competent person. Failure to install correctly could lead to prosecution.

If you are in any doubt, contact the Worcester Technical helpline (0844 892 3366).

Please leave these instructions with the completed BENCHMARK CHECKLIST, (or a certificate confirming compliance with IS 813, Eire only) and the user manual with the owner or at the gas meter after installation or servicing.

Distance learning and training courses are available from Worcester.

The BENCHMARK CHECKLIST can be found in the back of this Installation manual.

Table 3

∅	Diameter
NG	Natural Gas
LPG	Liquid Petroleum Gas
CH	Central Heating
DHW	Domestic Hot Water
DCW	Domestic Cold Water
PRV	Pressure Relief Valve
NTC	Negative Temperature Coefficient (sensor)
IP	Ingress Protection
RCD	Residual Current Device
TRV	Thermostatic Radiator Valve
ECV	Emergency Control Valve
WRAS	Water Regulations Advisory Scheme
SEDBUK	Seasonal Efficiency of Domestic Boilers in the United Kingdom

Table 4 Abbreviations used in this manual

1.2 SAFETY PRECAUTIONS

IF YOU SMELL GAS:

A gas leak could potentially cause an explosion. If you smell gas, observe the following rules.

- ▶ Prevent flames or sparks:
 - Do not smoke, use a lighter or strike matches.
 - Do not operate any electrical switches or unplug any equipment.
 - Do not use the telephone or ring doorbells.
- ▶ Turn off the gas at the meter.
- ▶ Open windows and doors.
- ▶ Leave the building and warn your neighbours.
- ▶ Prevent anyone from entering the building.
- ▶ Stay well away from the building: call the National Gas Emergency Service on 0800 111 999.

BOILER OPERATION:

This boiler must only be operated by a responsible adult who has been instructed in, understands, and is aware of the boiler's operating conditions and effects.



Benchmark places responsibilities on both manufacturers and installers. The purpose is to

ensure that customers are provided with the correct equipment for their needs, that it is installed, commissioned and serviced in accordance with the manufacturer's instructions by competent persons and that it meets the requirements of the appropriate Building Regulations. The Benchmark Checklist can be used to demonstrate compliance with Building Regulations and should be provided to the customer for future reference.

The guarantee of this product is dependant on the Benchmark checklist being completed and the actions undertaken.

Installers are required to carry out installation, commissioning and servicing work in accordance with the Benchmark Code of Practice which is available from the Heating and Hotwater Industry Council who manage and promote the scheme.

Visit centralheating.co.uk for more information.

HEALTH AND SAFETY

The appliance contains no asbestos and no substances have been used in the construction process that contravene the COSHH Regulations (Control of Substances Hazardous to Health Regulations 1988).

COMBUSTION AND CORROSIVE MATERIALS

Do not store or use any combustible materials (paper, thinners, paints etc.) inside or within the vicinity of the appliance.

Chemically aggressive substances can corrode the appliance and invalidate any guarantee.

FITTING AND MODIFICATIONS

Fitting the appliance and any controls to the appliance may only be carried out by a competent engineer in accordance with the current Gas Safety (Installation and Use) Regulations.

Flue systems must not be modified in any way other than as described in the fitting instructions. Any misuse or unauthorised modifications to the appliance, flue or associated components and systems could invalidate the guarantee. The manufacturer accepts no liability arising from any such actions, excluding statutory rights.

SERVICING

Advise the user to have the system serviced annually by a competent, qualified Gas Safe registered engineer. Approved spares must be used to help maintain the economy, safety and reliability of the appliance.

IMPORTANT

The service engineer must complete the Service Record on the Benchmark Checklist after each service.

INSTALLATION REGULATIONS

Current Gas Safety (Installation & Use) Regulations:

All gas appliances must be installed by a competent person in accordance with the above regulations.

Failure to install appliances correctly could lead to prosecution.

The appliance must be installed in accordance with, and comply to, the current: Gas Safety Regulations, IEE Regulations, Building Regulations, Building Standards (Scotland) (Consolidation), Building Regulations (Northern Ireland), local water by-laws, Health & Safety Document 635 (The Electricity at Work Regulations 1989) and any other local requirements.

BUILDING REGULATIONS PART L 1A 2010

If the installation is in a new build property or is a first time installation in an existing property, heating systems must conform to current building regulations Part L1a.

All new heating systems in dwellings must have at least two heating zones. Each of these zones will be operated separately by both time and temperature controls.

The exception to this are single storey, open plan dwellings where the living area is more than 70% of the total useable floor area. Then this type of dwelling can be controlled as one zone.

All radiators must have TRVs fitted, where reasonable, in all rooms except bathrooms and rooms with thermostats.

BUILDING REGULATIONS PART L 1B 2010 - BOILER REPLACEMENT

For boiler replacement on an existing system, it is not necessary to zone the system, compliance with the zone requirements can be achieved by a single room thermostat or programmable room thermostat.

BRITISH STANDARDS

Where no specific instruction is given, reference should be made to the relevant British Standard codes of Practice.

BS7074:1 Code of practice for domestic and hot water supply

BS6891 Installation of low pressure gas pipe work up to 28mm (R1)

BS5546 Installation of gas hot water supplies for domestic purposes

EN12828 Central heating for domestic premises

BS5440:1 Flues and ventilation for gas appliances of rated heating not exceeding 70kW (net) : Flues

BS5440:2 Flues and ventilation for gas appliances of rated heating not exceeding 70kW (net) :

Air Supply

BS7593 Treatment of water in domestic hot water central heating systems

BS6798 Installation of gas fired boilers of rated input up to 70kW (net)

Irish Standards

The relevant Irish standards should be followed, including:

- ECTI National rules for electrical installations
- IS 813:2002 for Domestic Gas Installations.

Timber framed building:

Where the boiler is to be fitted to a timber framed building the guidelines laid down in BS5440: Part 1 and IGE "Gas Installations in Timber Frame Buildings" should be adhered to.

Potable water:

All seals, joints and compounds (including flux and solder) and components used as part of the secondary domestic water system must be approved by WRAS.

CH Water:

Artificially softened water must not be used to fill the central heating system.

2 APPLIANCE INFORMATION

2.1 STANDARD PACKAGE

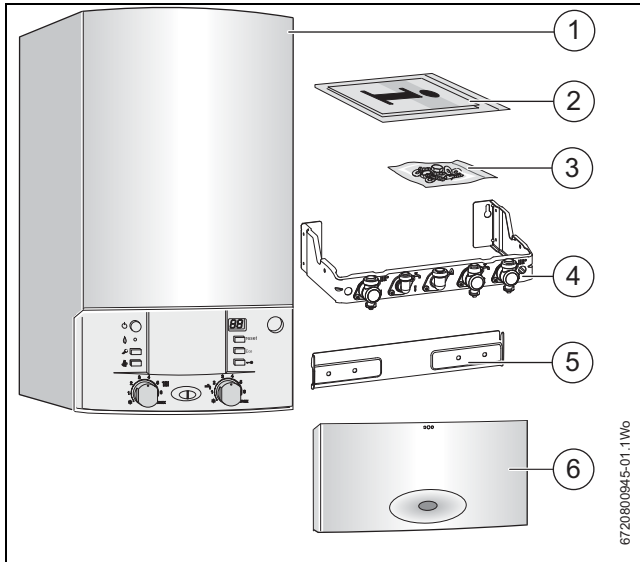

Fig. 1

Standard package contents:	
1	Gas Combi boiler
Bottom Tray	
2	Literature pack:
	- Installation instructions
	- User guide
	- Wall mounting template
	- PRV installer connection
	- Condensate adapter
3	Hardware pack:
	- Compression fittings
	- Fibre washers
5	Top wall hanging bracket
6	Fascia flap
Top Tray	
4	Isolating valve bracket

Table 5

2.2 BOILER FEATURES

- Gas condensing boiler
- Pump anti-seize protection
- Compatible with all Worcester standard and intelligent controls
- Mains electrical cable pre-wired to control board
- Built-in fault-finding diagnostics
- Automatic ignition
- Modulating output control
- No minimum water circulation rate required
- Suitable for underfloor heating
- Condensfit II flue systems 60/100 and 80/125mm allows plume re-direction as standard and ability to attach plume management kits
- Variable speed fan
- Premix burner
- Three-speed heating circulating pump with automatic air vent
- Pressure relief valve, pressure gauge, expansion vessel
- Flue gas temperature limiter (120 °C)
- Motorised 3-way diverter valve delivering DHW as a priority
- Plate heat exchanger
- Condensate trap
- Top wall hanging plate
- Isolating valves hanging bracket for pre-plumbing

2.3 TECHNICAL DATA

Greenstar 24, 28, and 30	UNIT	24	28	30
Domestic Hot Water				
Minimum heat input	kW	7.5	7.5	7.3
Maximum rated heat output	kW	24	28	29.6
Maximum rated heat input (net)	kW	24.6	28	30
Maximum mains inlet pressure (standing pressure)	bar	10	10	10
Minimum mains inlet pressure (working) for max. flow	bar	1.5	1.5	1.5
Minimum mains inlet pressure (working) for operation	bar	0.2	0.2	0.3
Domestic hot water temp. range	°C	40-60	40-60	40-60
Domestic Hot water specific rate - 30 °C rise	l/min	11.4	13.4	14.0
Max. Domestic Hot Water flow rate - 40 °C rise ± 15%	l/min	8.6	10.0	10.5
Gas flow rate - Max. 10 minutes from lighting				
Natural Gas G20	m ³ /h	2.5	2.8	3.0
Central Heating				
Max. rated heat output 40/30°C	kW	21.8	21.8	21.8
Max. rated heat output 50/30°C	kW	21.6	21.6	21.6
Max. rated heat output 80/60°C	kW	20.3	20.3	20.3
Max. rated heat output with low NOx	kW	14.1	14.1	14.1
Maximum flow temperature	°C	88	88	88
Max. permissible operating pressure	bar	2.5	2.5	2.5
Available pump head at 20°C system temperature rise	m	2	2	2
Flue				
Flue gas temperature 80/60°C, rated/min. load	°C	85/61	94/61	94/61
Flue gas temperature 40/30°C, rated/min. load	°C	60/32	60/32	60/32
CO ₂ level at max. rated heat output (after 30 minutes)	%	9.6	9.6	9.8
CO ₂ level at min. rated heat output (after 30 minutes)	%	8.7	8.7	8.8
Standard NOx class & rating mg/kWh	5	42.0	42.0	42.0
Low NOx class & rating mg/kWh	5	37.8	37.8	37.8
Condensate				
Maximum condensate rate	l/h	1.7	1.7	1.7
pH value, approx.		4.8	4.8	4.8
Electrical				
Electrical power supply voltage	a.c. V	230	230	230
Frequency	Hz	50	50	50
Max. power consumption - running	W	125	125	130
Maximum power consumption - stand-by	W	4	4	4
General data				
Appliance protection rating	IP	IP X4D	IP X4D	IP X4D
Appliance protection rating with FW100 or FR110 module fitted	IP	IP20	IP20	IP20
Permissible ambient temperatures	°C	0 - 50	0 - 50	0 - 50
Nominal capacity of appliance	litre	3	3	3
Total boiler weight	kg	48.6	48.6	48.6
Lift weight	kg	45.6	45.6	45.6
SEDBUK 2005	Band A	90.0%	90.0%	90.0%
SEDBUK 2009	Annual	88.6%	88.6%	88.6%

Table 6

2.4 APPLIANCE LAYOUT

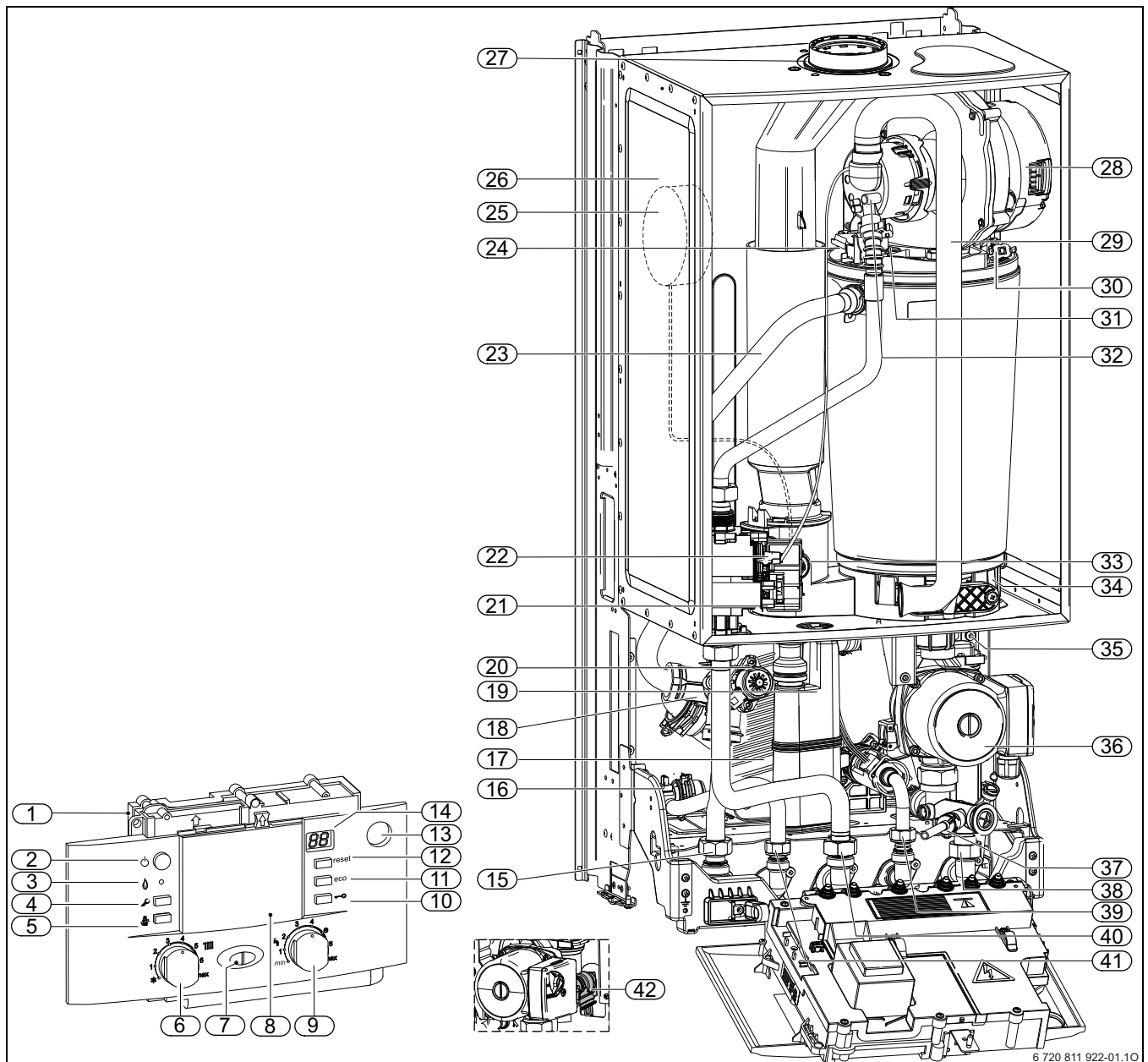

6 720 811 922-01.10

Fig. 2 Main boiler components

- | | |
|--|--|
| [1] Control panel | [22] Inlet pressure test point |
| [2] ON/OFF button | [23] CH flow |
| [3] Burner ON indicator light (green) | [24] Flow temperature sensor (NTC) |
| [4] Service button | [25] Air pressure switch (30 kW only) |
| [5] Performance test button | [26] Expansion vessel |
| [6] CH temperature control | [27] Flue connector |
| [7] Mains ON/OFF indicator / diagnostic light (blue) | [28] Fan |
| [8] Position for optional plug-in control | [29] Combustion air inlet |
| [9] DHW temperature control | [30] Maximum safety sensor (NTC) |
| [10] Key lock | [31] Electrode assembly |
| [11] eco button | [32] Fan pressure test point |
| [12] Fault reset button | [33] Flue overheat thermostat |
| [13] System pressure gauge | [34] Sump assembly |
| [14] Display | [35] Auto air vent |
| [15] CH flow pipe to isolating valve | [36] Pump |
| [16] DHW temperature sensor | [37] Drain point |
| [17] DHW plate heat exchanger | [38] CH return connection to isolating valve |
| [18] 3-way diverter valve | [39] DCW in connection to isolating valve |
| [19] Condensate trap | [40] Gas pipe from isolating valve |
| [20] Diverter valve actuator (stepper motor) | [41] DHW outlet pipe |
| [21] Gas valve | [42] Safety valve (heating circuit) |

3 PRE-INSTALLATION

3.1 CLEANING PRIMARY SYSTEMS

CAUTION:

- ▶ ISOLATE THE MAINS SUPPLIES BEFORE STARTING ANY WORK AND OBSERVE ALL RELEVANT SAFETY PRECAUTIONS.

NOTICE:

- ▶ All the following pre-installation sections must be read and requirements met before starting the boiler or flue installations.

NOTICE:

- ▶ Debris from the system can damage the boiler and reduce efficiency. Failure to comply with the guidelines for the use of water treatment with the appliance will invalidate the appliance guarantee and contravene the Building Regulations.
- ▶ It is recommended that you fit a primary water cleanser to the system. Worcester recommends a filter that will help remove both magnetite and non-magnetic debris.

BEFORE CLEANING THE SYSTEM:

- ▶ Ensure that the system and pipe work is in good working order.
- ▶ **Where possible keep the existing boiler/circulating pump in place when flushing the system.**

FOLLOW THE GUIDANCE OF BS7593:

Treatment of water in domestic hot water central heating and also the flushing guidelines below.



NOTICE: Artificially softened water must not be used to fill the central heating system.

FLUSHING THE SYSTEM

- ▶ Fill the system with cold water and check for leaks.
- ▶ Open all drain cocks and drain the system.
- ▶ Close drain cocks and add a suitable flushing agent **compatible with aluminium** at the correct strength for the system conditions in accordance with the manufacturer's instructions.
The pH value of the system water must be less than 8 or the appliance guarantee will be invalidated.
- ▶ Circulate the flushing agent before the boiler is fired up.
- ▶ Run the boiler/system at normal operating temperature as directed by the manufacturer of the flushing agent.
- ▶ Drain and thoroughly flush the system to remove the flushing agent and debris.
- ▶ It may be necessary to use a power flushing machine to aid the cleansing procedure in some circumstances.
- ▶ Close the drain cocks and refill with fresh water and a suitable inhibitor.
- ▶ Vent any air from the boiler and system.

INHIBITOR

Add a suitable inhibitor or combined inhibitor/anti-freeze, if the system is exposed to freezing conditions, to the heating system in accordance with the DWTA code of practice and manufacturer's guidelines.

WARNING: Sealing agents

- ▶ Normally the addition of sealing agents to the system water is not permitted as this can cause problems with deposits left in the heat exchanger.
- ▶ In cases where all attempts to find a micro leak have failed, Worcester, Bosch Group supports the use of Fernox F4 leak sealer.

WATER TREATMENT PRODUCTS

Suitable water treatment products can be obtained from the following manufacturers:

FERNOX	0870 601 5000 or www.fernox.com
SENTINEL	0800 389 4670 or www.sentinel-solutions.net

Table 7

ARTIFICIALLY SOFTENED WATER

It is possible to have an Ion exchange water softener fitted to the cold water system of the property. However, the boiler requires an untreated cold water connection taken from the mains supply, before the water softener, to the primary water filling point of the heating system.

Alternatively there are water softening/treatment devices that do not adjust or alter the pH levels of the water. With these devices it may not be necessary to provide an untreated water by-pass to the primary water filling point of the heat system.

3.2 MAINS SUPPLY

3.2.1 ELECTRICAL SUPPLY

- Supply: 230V - 50 Hz, 130 Watts
- Cable: PVC insulated H05VVf 3G1 (3 x 1mm²) temperature rated to 90 °C.
- External 3A fuse to BS1362.
- The boiler must be earthed.
- This boiler must not be connected to a 3 phase supply.
- IPX4D.



NOTICE: This is reduced to IP20 if the following mechanical timers are fitted;
7 716 192 036 or 7 716 192 037
or FW100 7 716 192 067

- Wiring must comply with the latest edition of BS 7671 (IEE wiring regulations).

3.2.2 GAS SUPPLY

- Boilers using Natural Gas (NG) must be connected to a governed meter.
- Installation and connection of the gas supply to the boiler must be in accordance with BS6891.
- Under no circumstance should the size of the gas supply pipe be less than 22 mm.
- The meter or regulator and pipe work to the meter must be checked, preferably by the gas supplier.
This is to ensure that the equipment is in good working order and can meet the gas flow and pressure requirements, in addition to the demand from any other appliance being served.

3.2.3 WATER SUPPLY

WATER MAINS PRESSURE:

- Minimum mains water pressure for maximum performance: 1.5 bar.
- Maximum mains fed water pressure 10 bar.
If necessary fit a pressure reducing valve.

 **NOTICE:** Non return, back flow prevention devices (including those associated with water meters) fitted to the mains water supply can cause a pressure build up which could damage the boiler and other household appliances.

- Where the mains water supply has a non-return, back flow prevention valve fitted, a mini expansion vessel (1) should be connected to the mains water inlet pipe (2) between the non-return valve (3) and the boiler (4) as shown below.

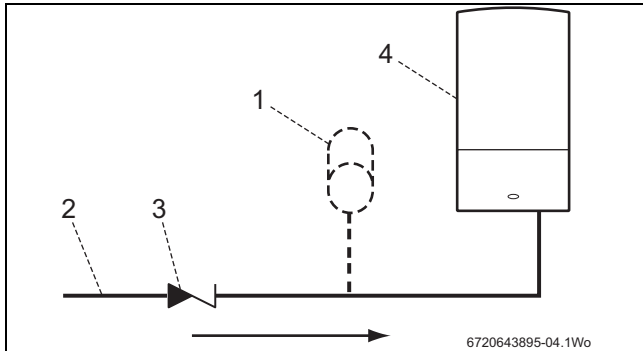

Fig. 3

- [1] Mini expansion vessel - part no. 7 716 192 105
- [2] Mains water inlet pipe
- [3] Non return valve
- [4] Boiler

USE IN HARD WATER AREAS:

Normally there is no need for water treatment to prevent scale formation as the maximum temperature of the DHW heat exchanger is limited by the electronic control.

In areas where temporary water hardness exceeds 200 ppm, consideration may need to be given to the fitting of a scale prevention device. In such circumstances, the advice of the local water authority should be sought.

3.3 WATER SYSTEMS AND PIPE WORK

PLASTIC PIPE WORK:

- Any plastic pipe work must have a polymeric barrier with 600mm (minimum) length of copper pipe before being connected to the boiler.
- Plastic pipe work used for underfloor heating must be correctly controlled with a thermostatic blending valve limiting the temperature of the circuits to approximately 50°C.

PRIMARY SYSTEMS CONNECTIONS/VALVES:

- All system connections, taps and mixing valves must be capable of sustaining a pressure up to 3 bar.
- Radiator valves should conform to BS2767:10.
- All other valves should conform to BS1010.
- Thermostatic radiator valves (TRV's) must be fitted to all rooms except bathrooms and the room in which the room thermostat is fitted.
- A drain cock is required at the lowest point(s) in the system.
- An air vent is required at the high point(s) in the system.

 The boiler is equipped with an internal by-pass. The internal bypass is not intended to be a substitute for an external system bypass. An external automatic bypass should be used if the system flow can be significantly adjusted or stopped by zone valves and thermostatic radiator valves (TRV).

SHOWERS/BIDETS:

- If a shower head can be immersed in water or comes closer than 25mm from the top edge of a bath or shower tray spill over level then an anti-syphon device must be fitted to the shower hose.
- Bidets with direct hot and cold mains water can be used (with the approval of the local water authority) and must be the over rim flushing type with shrouded outlets to prevent the fitting of hand held sprays.

SEALED PRIMARY SYSTEM:

 **NOTICE:** ARTIFICIALLY SOFTENED WATER MUST NOT BE USED TO FILL THE CENTRAL HEATING SYSTEM

- The CH sealed system must be filled using a WRAS approved filling loop or comply with figure 4 for system fill.
- Where the system volume is more than 100 litres or exceeds 2.65 bar at maximum heating temperature, an extra expansion vessel (2) must be fitted as close as possible to the appliance in the central heating return.
- Pressurise the extra expansion vessel (2) to the same figure as the expansion vessel built into the appliance.
- **Do not use galvanised pipes or radiators.**

SYSTEM FILL

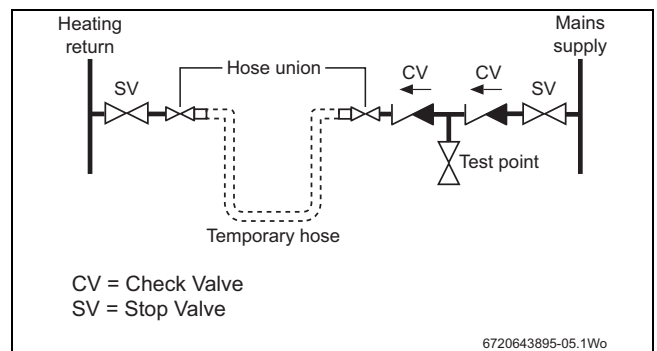

Fig. 4 System fill

TYPICAL SEALED SYSTEM

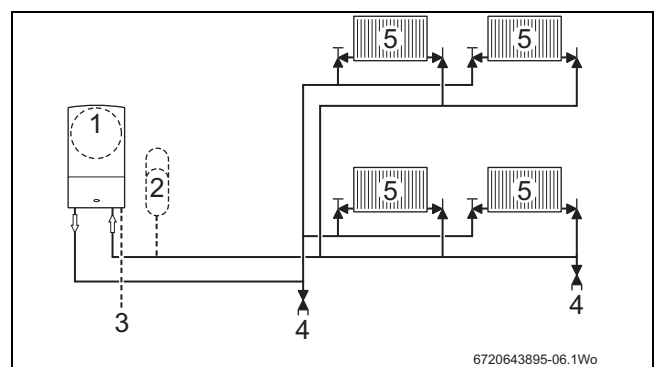

Fig. 5 Sealed system

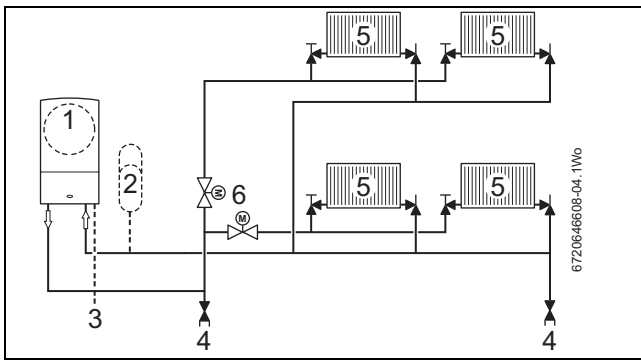

Fig. 6 Sealed system with zone valves

1	Appliance expansion vessel - CH
2	Extra expansion vessel - CH return
3	Pressure relief discharge
4	Drain cock
5	Radiators
6	Zone valves

Table 8 Key to figs. 3 5 and 6 4

3.4 CONDENSATE PIPE WORK

NOTICE:

- ▶ Where a new or replacement boiler is being installed, access to an internal "gravity discharge" point should be one of the factors considered in determining boiler location.
- ▶ The condensate pipe must be nominally 22mm Ø plastic pipe.
- ▶ The condensate pipe work must fall at least 52mm per metre towards the outlet and should take the shortest practicable route.
- ▶ Ensure there are no blockages in the pipe run.

Key to condensate illustrations (Fig. 7 - Fig. 13)

1	Condensate discharge from boiler
2	Soil and vent stack
3	Minimum 450mm and up to three storeys
4	Visible air break at plug hole
5	Sink or basin with integrated overflow
6	75mm sink waste trap
7	Condensate pump
8	PVCu strap on fitting
9	100mm Ø minimum plastic pipe
10	Drainage holes
11	Limestone chippings
12	Bottom of sealed tube
13	Insulate and increase pipe size
14	Pipe work transition
15	External air break
16	Air gap
17	External rain water pipe into foul water
18	43mm 90° male/female bend
*	Condensate trap of 75mm already incorporated into the boiler

Table 9

3.4.1 INTERNAL CONNECTIONS

In order to minimise risk of freezing during prolonged cold spells, the following methods of installing condensate drainage pipe should be adopted, in order of priority.

Wherever possible, the condensate drainage pipe should be routed and terminated so that the condensate drains away from the boiler under gravity to a suitable internal foul water discharge point such as an internal soil and vent stack. A suitable permanent connection to the foul waste pipe should be used.

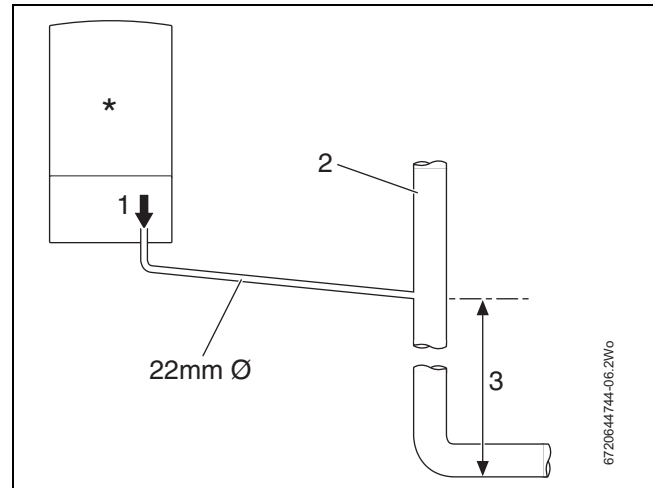

Fig. 7 Disposal to soil vent stack

Alternatively if the first option is not possible an internal kitchen or bathroom waste pipe, washing machine waste pipe etc. can be used. Ensure that the condensate drain pipe is connected "down stream" of the waste trap.

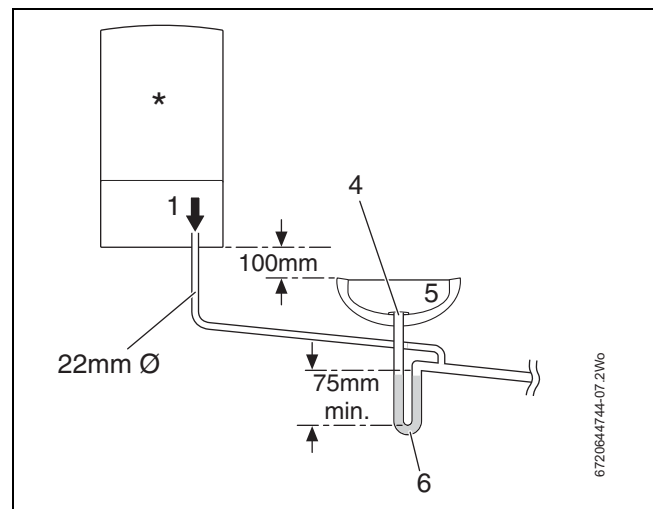

Fig. 8 Disposal to a waste pipe

CONDENSATE PUMP

Where "gravity discharge" to an internal termination is not physically possible, or where very long internal runs would be required to reach a suitable discharge point, condensate should be removed using a proprietary condensate pump, of a specification recommended by the boiler or condensate pump manufacturer.

The pump outlet pipe should discharge to a suitable internal foul water discharge point such as an internal soil and vent stack, internal kitchen or bathroom waste pipe, washing machine waste pipe etc. A suitable permanent connection to the foul waste pipe should be used.

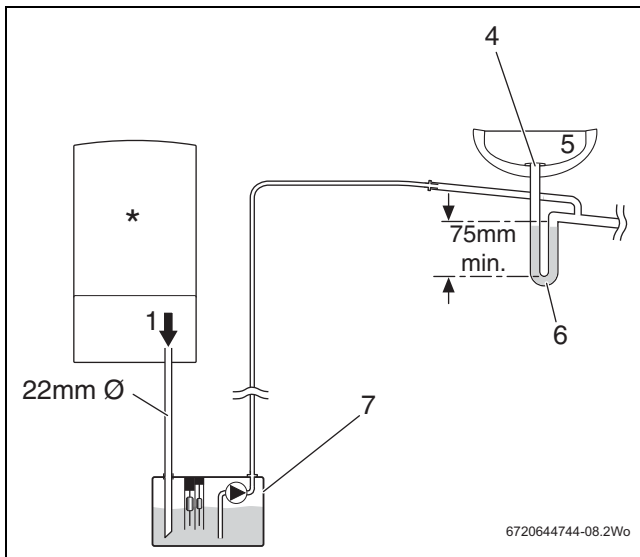

Fig. 9 Condensate pump disposal

3.4.2 EXTERNAL CONNECTIONS

NOTICE: Freezing conditions

- ▶ Pipe work length should be kept to a minimum and the route as vertical as possible.
- ▶ Weather proof insulation must be used.

NOTICE: Condensate waste

- ▶ Care should be taken when siting a soak-away to avoid obstructing existing services.

If no other discharge method is possible then the use of an externally run condensate drainage pipe terminating at a suitable foul water discharge point, or purpose-designed soak away, may be considered. If this method is chosen then the following measures should be adopted:

- ▶ The external run be kept as short as possible and not exceed three metres.
- ▶ The pipe should be run internally as far as possible before going externally and the pipe diameter should be increased to 32mm before it passes through the wall to the exterior. The pipe should be insulated using suitable waterproof and weather resistant insulation.
- ▶ The external pipe should take the shortest and least exposed route to the discharge point, and should "fall" as steeply as possible away from the boiler, with no horizontal runs in which condensate might stand.
- ▶ The use of fittings, elbows etc. should be kept to a minimum and any internal "burrs" on cut pipe work should be removed so that the internal pipe section is as smooth as possible.

FITTING AN EXTERNAL AIR BREAK

- Refer to figure 10 when a rain water down pipe is used to dispose of condensate.
- An air break must be installed in the 43mm pipe work, between the boiler condensate outlet and the drainpipe, outside the property, to avoid flooding during adverse weather conditions.

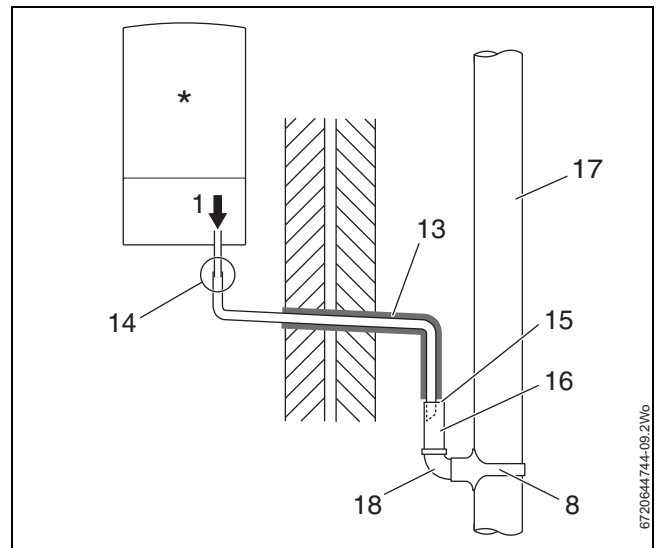

Fig. 10 Disposal into a rainwater down pipe



Condensate drainage pipe can be run above or below ground.

Where the pipe terminates over an open drain or gully, the pipe should terminate below the grating level, but above water level, in order to minimise "wind chill" at the open end.

The use of a drain cover (such as those used to prevent blockage by leaves) may offer further protection from wind chill.

Pipe drainage will be improved if the end is cut at 45° as opposed to a straight cut.

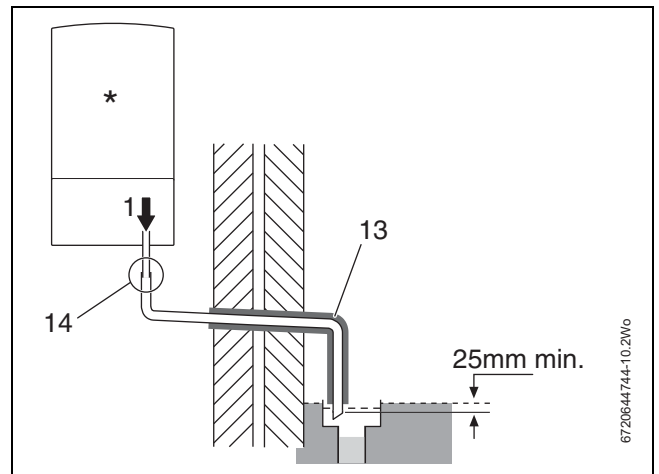

Fig. 11 External disposal

CONDENSATE SOAK AWAY

- The condensate drainage pipe may be run above or below the ground to the soak away. The examples shown on this page run above ground.
- The soak away must use a 100mm Ø plastic tube with two rows of three 12mm holes on 25mm centres and 50mm from the bottom of the tube. The holes must face away from the house.
- The tube must be surrounded by at least 100mm of limestone chippings to a depth of 400mm.



Minimum hole size for the condensate soak away must be 400mm deep by 300mmØ.

In situations where there are likely to be extremes of temperature or exposure, the use of a proprietary trace-heating system for external pipe work, incorporating an external frost thermostat, should be considered. If such a system is used, the requirement to use 32mm pipe does not apply. However, all other guidance above and the instructions for the trace heating system, should be closely followed.

NOTICE: Unheated internal areas.

- Internal pipe runs in unheated areas such as lofts, basements and garages should be treated as external runs.

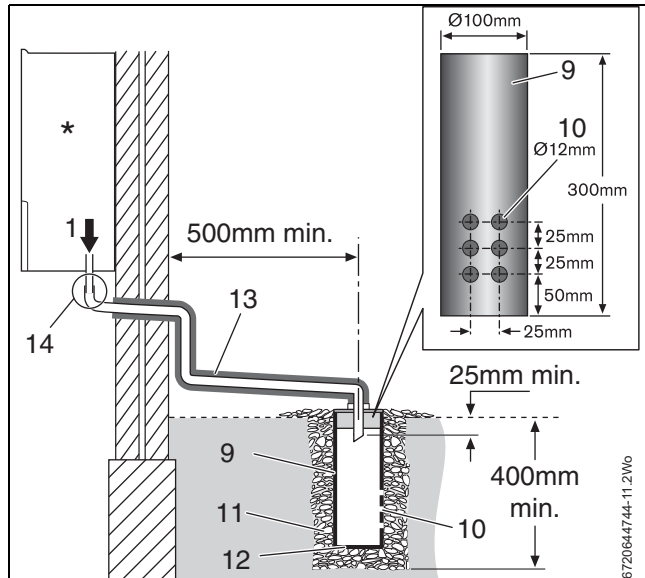

Fig. 12 Soak away

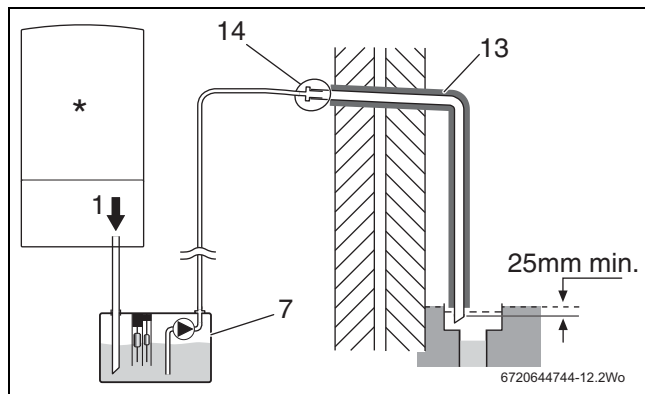

Fig. 13 Condensate pump to external disposal

3.5 PRESSURE RELIEF PIPE WORK

NOTICE:

- The pressure relief valve is a safety device for the boiler and if activated may discharge boiling water or steam through the relief valve drain pipe.
- Care should be taken when siting the outlet pipe so that it does not cause an obstruction or discharge above a window, entrance or other public access where it could cause a hazard.

- The pressure relief drain pipe (1) from the boiler should be at least 15mm diameter copper pipe and run downwards, away from any electrical equipment or other hazard, preferably to an external drain or soak away.

- The pressure relief drain pipe (1) should be finished with a partial bend, near the outlet to face the external wall (as shown) to help prevent freezing.

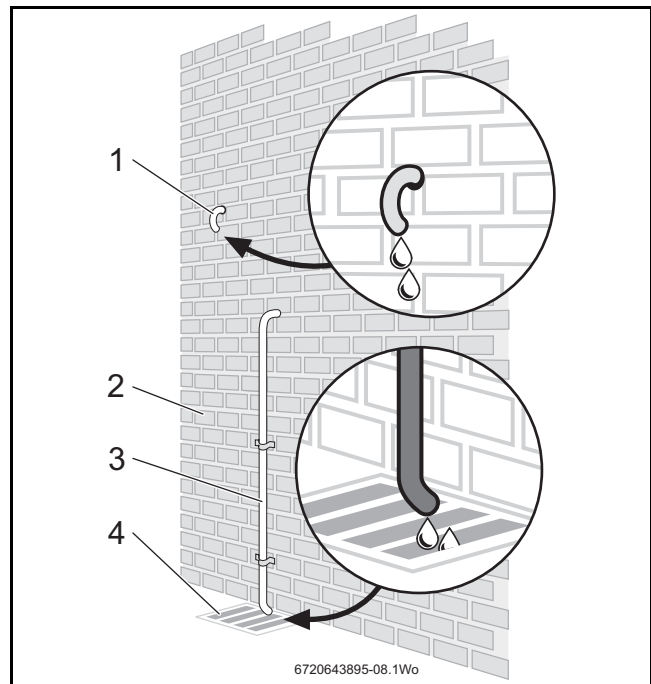

Fig. 14 Pressure relief pipe work

2	Outside wall
1,3	Drain pipe
4	External drain

Table 10 Key to fig 7

3.6 BOILER LOCATION AND CLEARANCES

3.6.1 INSTALLATION

This boiler is only suitable for installing internally within a property at a suitable location onto a fixed, rigid surface at least the same size as the boiler and capable of supporting the boiler weight.



NOTICE:
No surface protection is required against heat transfer from the boiler

3.6.2 INSTALLATION AND SERVICING CLEARANCES - UNVENTILATED COMPARTMENTS

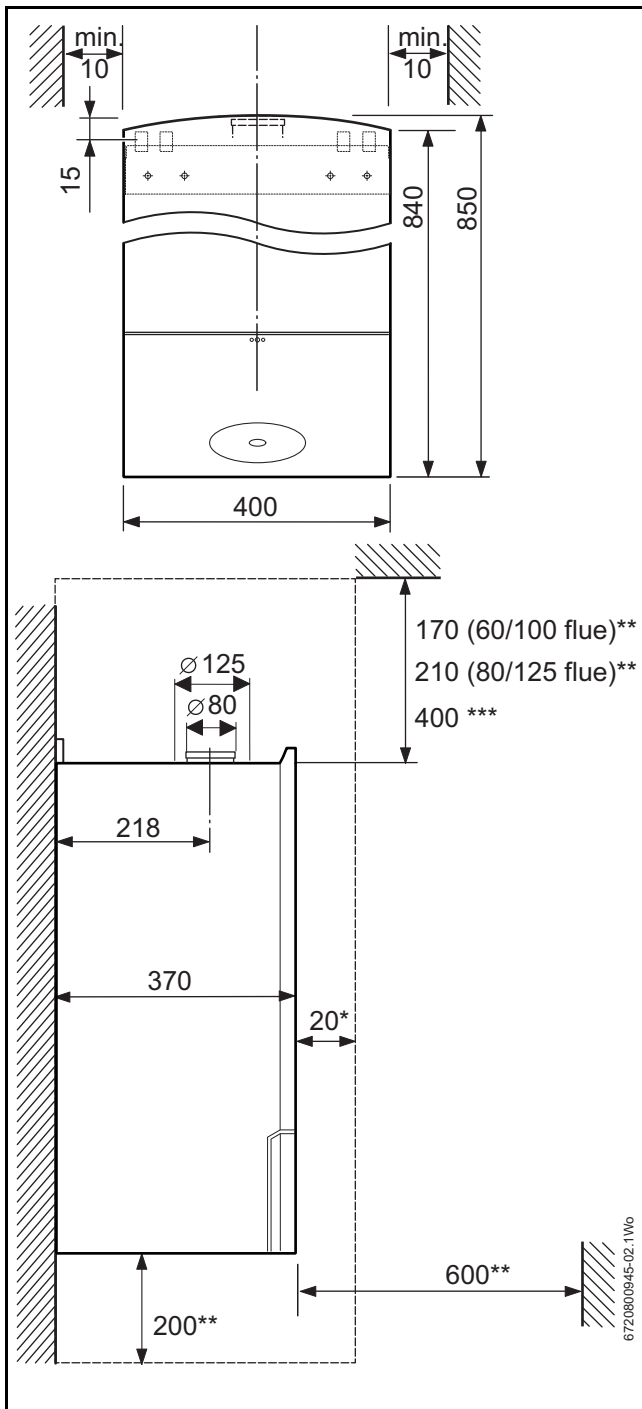

Fig. 15 Compartment clearances

- [*] Minimum clearance to removable door
- [**] Minimum clearance required for servicing
- [***] Minimum clearance required to remove expansion vessel with boiler mounted with left or right flue exit

3.6.3 COMPARTMENTS

Follow the requirements of BS6798 and BS5440 Part 2 and note:

- Minimum clearances must be maintained.
- An access door is required to install, service and maintain the boiler and any ancillary equipment.
- If fitting the boiler into an airing cupboard use a non-combustible material to separate the boiler from the airing space.
The material can be perforated up to a maximum hole size of 13mm.

3.6.4 BATHROOMS

A boiler fitted with a mechanical timer or RF mechanical timer (receiver) or FW100 controller may only be installed outside the shaded area.

A boiler with any other timer fitted (or blanking panel) can also be installed in zone 2.

Additional RCD (Residual Current Device) protection may be required. Consult the latest version of BS7671 (IEE wiring regulations).

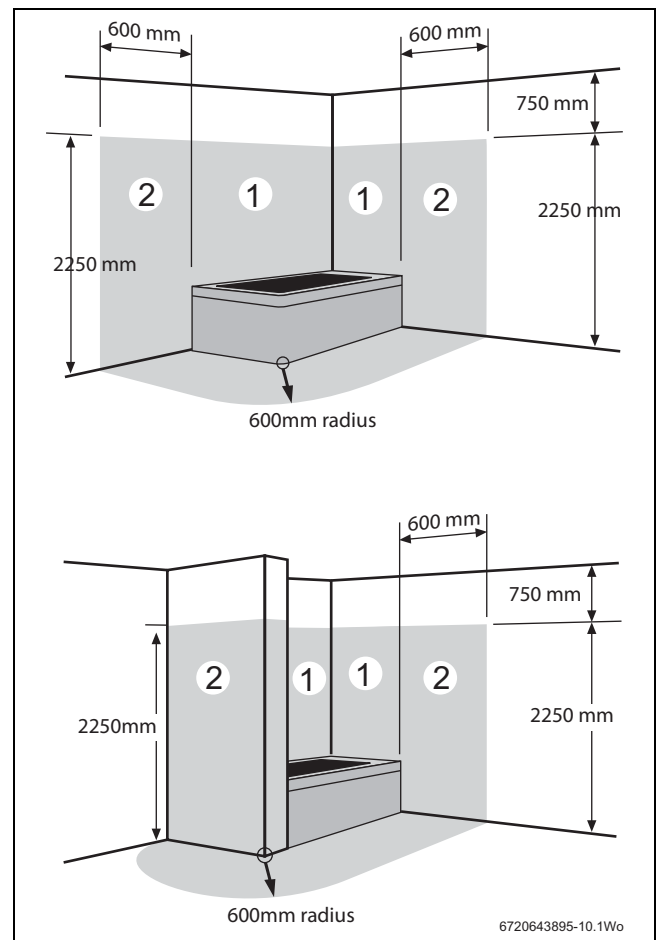



Fig. 16 Bathroom installations

3.7 FLUE OPTIONS



CAUTION: Non accessible flue systems:

- ▶ Where a flue system is not going to be accessible, provision must be made for service and inspection.
- ▶ Voids containing concealed flues must have at least one inspection hatch no less than 300mm square.
- ▶ Flue joints within the void must not be more than 1.5 metres from the edge of the inspection hatch.
- ▶ Inspection hatches should be located at changes of direction.
- ▶ If this is not possible, bends should be viewable from both directions.

**NOTICE:** Effective flue lengths:

- ▶ each 90° bend is equivalent to 2 metres of straight flue
- ▶ each 45° bend is equivalent to 1 metre of straight flue



The maximum plume management length for any flue length for the appliances mentioned on the front of this manual is 4.5 metres.

Plume management kits are available for the 60/100 horizontal flue system,
Part number 7 716 191 086.

Refer to the manual supplied with the Plume Management kits for complete installation instructions

Condensfit II

Greenstar 24/28/30 boilers		Maximum total flue length L (mm)	
		60/100	80/125
FLUE TYPE			
1	Telescopic horizontal flue assembly	130 - 570	405 - 600
	Longer telescopic horizontal flue assembly	570 - 790	NA
2	Horizontal flue extension	4,600	15,000
3	Horizontal flue with 1 x 90° bend	2,600	13,000
4	Horizontal flue with 2 x 90° bends	N/A	11,000
5	High level horizontal flue	4,600	15,000
6	High level horizontal flue with 2 x 90° bends	2,600	13,000
7	High level horizontal flue with 3 x 90° bends	N/A	11,000
8	Vertical balanced flue assembly	6,000	15,000
9	Vertical balanced flue with 2 x 90° bends	2,000	11,000
10	Vertical balanced flue with 2 x 45° bends	4,000	13,000

Table 11 Flue options

The flue systems have different maximum flue lengths

The Greenstar series has the option of two horizontal 60/100 RSF (telescopic and longer telescopic) and one horizontal 80/125 RSF (telescopic) flue system and two vertical RSF (60/100 or 80/125) flue systems:

The next page shows various fluing options.

Refer to the Flue options in table 11 for the straight flue lengths required to achieve the maximum flue length.

Part number	Flue	Description
7 716 191 082	60/100	Telescopic horizontal flue assembly
7 716 191 171	60/100	Longer telescopic horizontal flue assembly
7 719 003 702	80/125	Telescopic horizontal flue assembly
7 719 002 430	60/100	Vertical flue assembly
7 719 002 431	80/125	Vertical flue assembly

Table 12 Flue part numbers

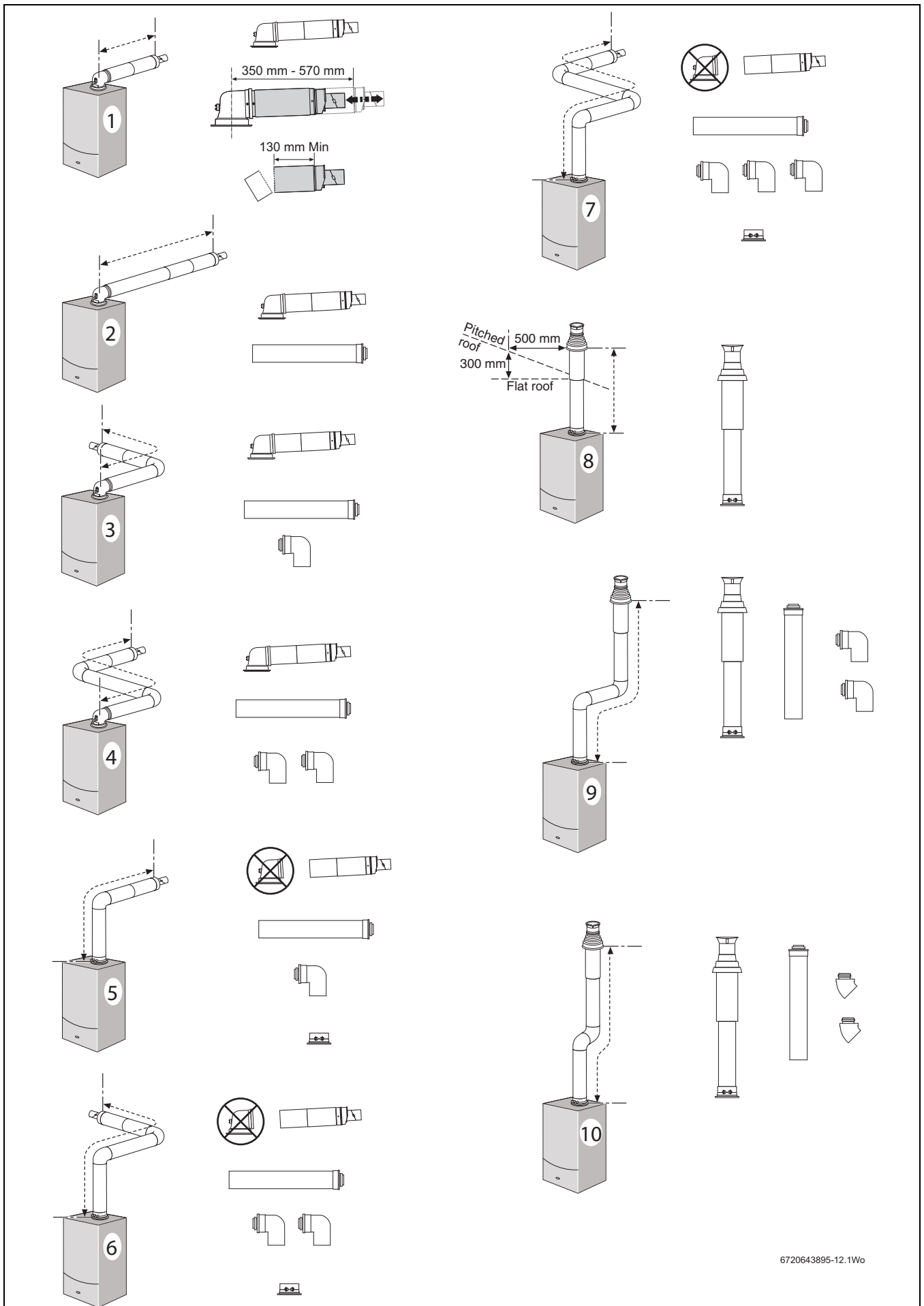

6720643895-12.1W6

Fig. 17

3.8 FLUE TERMINAL POSITIONS

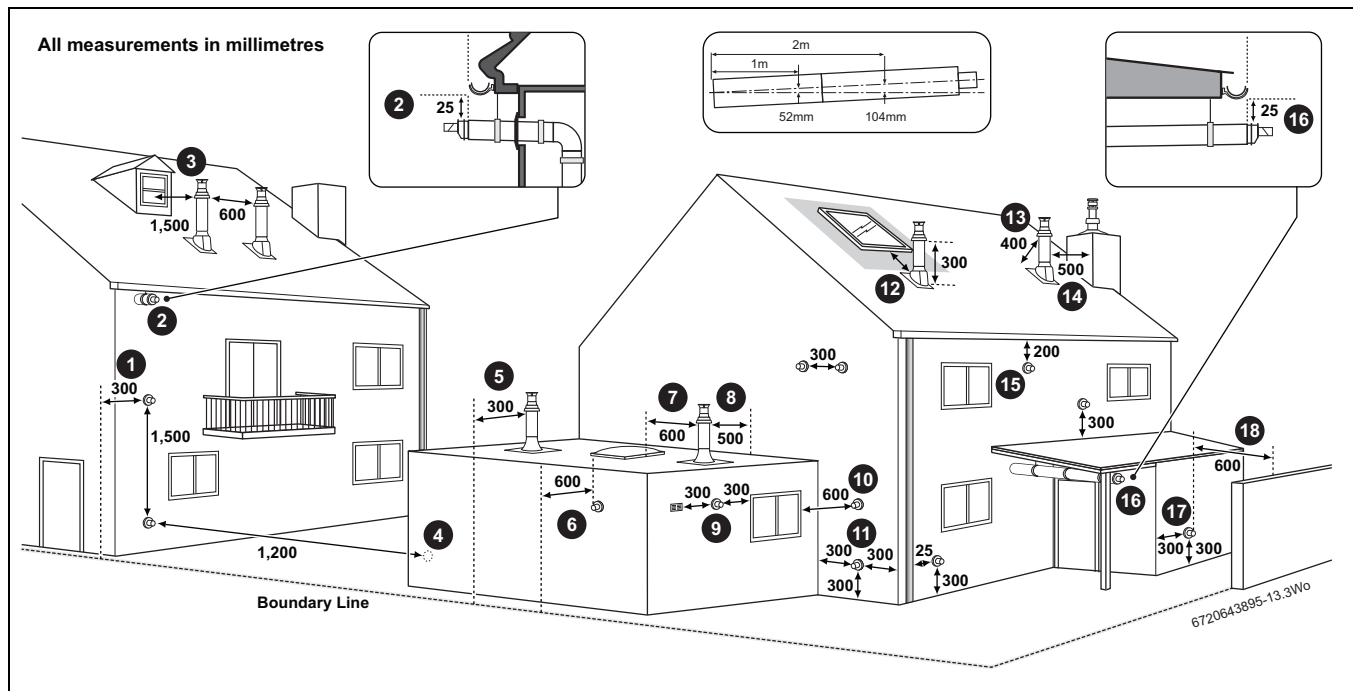

Fig. 18 Flue terminal positions



NOTICE:

- ▶ All measurements are the minimum clearances required.
- ▶ Terminals must be positioned so to avoid combustion products entering the building.
- ▶ Support the flue at approximately one metre intervals and at a change of direction, use suitable brackets and fittings (flue brackets 100mm x 6 part number: 7 716 191 173, flue bracket 125mm part number: 7 716 191 174).

Key to illustration

1. 300mm adjacent to a boundary line.
2. The dimension below eaves, balconies and car ports can be reduced to 25mm, as long as the flue terminal is extended to clear any overhang. Any external flue joints must be sealed with suitable silicon sealant.
3. 1,500mm between a vertical flue terminal and a window or dormer window.
4. 1,200mm between terminals facing each other.
5. Vertical flue clearance, 300mm adjacent to a boundary line.
6. 600mm distance to a boundary line, unless it will cause a nuisance. BS 5440: Part 1 recommends that care is taken when siting terminal in relation to boundary lines.
7. 600mm minimum clearance from a skylight to a vertical flue.
8. Vertical flue clearance, 500mm to non-combustible building material, and 1,500mm clearance to combustible building material.
9. 300mm above, below and either side of an opening door, air vent or opening window.
10. 600mm diagonally to an opening door, air vent or opening window.
11. 300mm to an internal or external corner.
12. 2,000mm below a Velux window, 600mm above or to either side of the Velux window.
13. 400mm from a pitched roof or in regions with heavy snow fall 500mm.
14. 500mm clearance to any vertical structure on a roof, 600mm to room sealed flue or 1,500 to an open flue.
15. 200mm below eaves and 75mm below gutters, pipe and drains.
16. The dimension below eaves, balconies and car ports can be reduced to 25mm, as long as the flue terminal is extended to clear any overhang. Any external flue joints must be sealed with suitable silicon sealant.

17. Flue clearance must be at least 300mm from the ground. Terminal guards must be fitted if the flue is less than 2 metres from the ground or if a person could come into contact with the flue terminal.

18. 600mm distance to a surface facing a terminal, unless it will cause a nuisance. BS 5440: Part 1 recommends that care is taken when siting terminals in relation to surfaces facing a terminal.



Note:

- ▶ Installations in car ports are not recommended.
- ▶ The flue cannot be lower than 1,000mm from the top of a light well due to the build up of combustion products.
- ▶ Dimensions from a flue terminal to a fanned air inlet to be determined by the ventilation equipment manufacturer.

3.9 PLUME MANAGEMENT TERMINAL POSITIONS

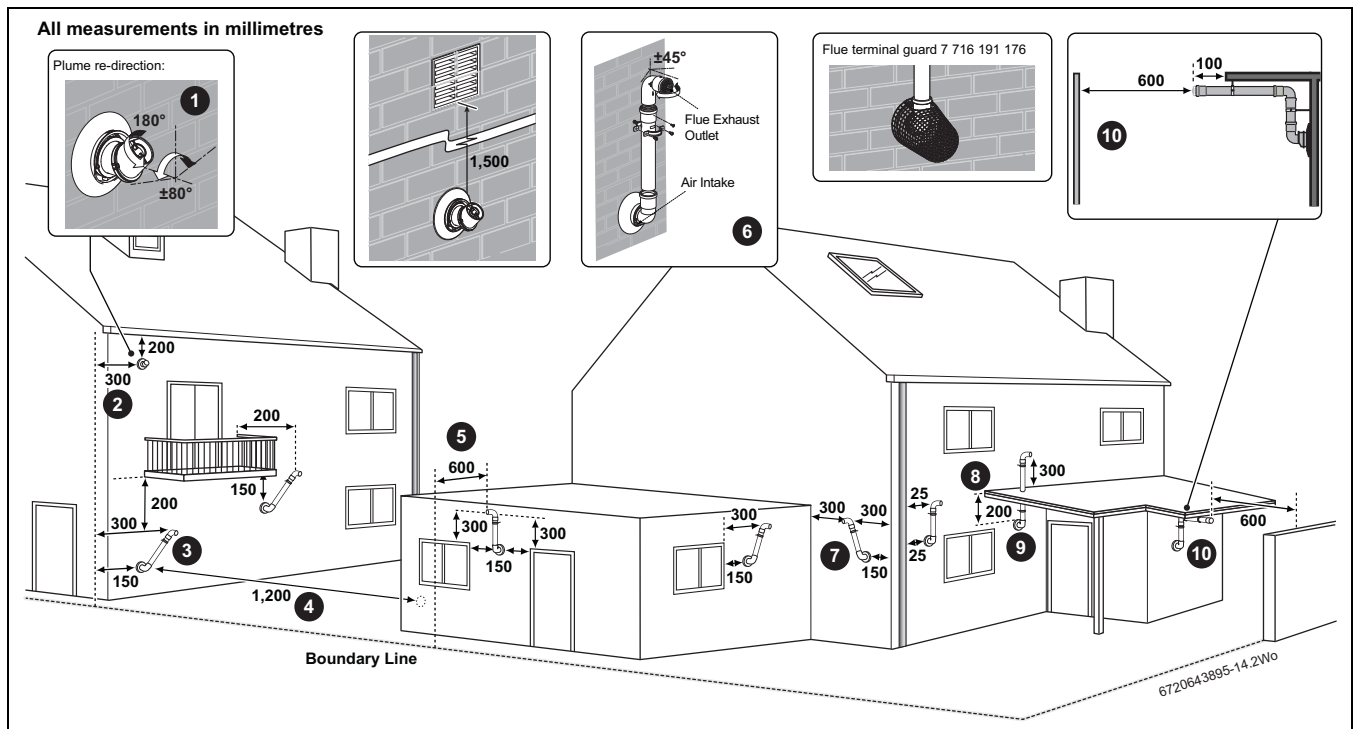

Fig. 19 Plume terminal positions



The minimum plume management length for any length of flue is 500mm and the maximum length is 4.5 metres for the appliances detailed on the front of this manual.
The 45° bend is equivalent to 0.75 metres of straight plume management and the 90° bend is equivalent to 1.5 metres.



NOTICE:

- ▶ All measurements are the minimum clearances required.
- ▶ Refer to figure 15 for all concentric flue terminal positions unless the flue position is specified on the figure above “Plume terminal positions”.
- ▶ Terminals must be positioned so to avoid combustion products entering the building.
- ▶ Support the flue at approximately one metre intervals and at a change of direction, use suitable brackets and fittings.

Key to illustration

1. This feature allows some basic plume re-direction options on a standard telescopic horizontal flue terminal.
300mm minimum clearances to a opening e.g. window.
However the minimum clearances to an opening in direction that the plume management is facing, must be increased to 1,500mm.
Where the flue is less than 150mm to a drainpipe and plume re-direction is used the deflector should not be directed towards the drainpipe.
2. 300mm adjacent to a boundary line.
3. Plume Management Kit air intake can be reduced to 150mm providing the flue exhaust outlet is no less than 300mm adjacent to a boundary line.
4. 1,200mm between terminals facing each other.
5. 600mm distance to a boundary line, unless it will cause a nuisance. BS 5440:Part 1 recommends that care is taken when siting terminal in relation to boundary lines.
6. Using a Plume Management Kit the air intake measurement can be reduced to 150mm providing the flue exhaust outlet has a 300mm clearance.
Plume kits running horizontally must have a 10° fall back to the boiler for proper disposal of condensate.
For details on specific lengths see relevant boiler Technical & Specification information.

7. Internal/external corners. The air intake clearance can be reduced to 150mm providing the flue exhaust outlet has a 300mm clearance.
8. Clearances no less than 200mm from the lowest point of the balcony or overhang.
9. 1,200mm from an opening in a car port on the same wall e.g. door or window leading into the dwelling.
10. 600mm distance to a surface facing a terminal, unless it will cause a nuisance. BS 5440: Part 1 recommends that care is taken when siting terminals in relation to surfaces facing a terminal.



Note:

- ▶ Installations in car ports are not recommended.
- ▶ The flue cannot be lower than 1,000mm from the top of a light well due to the build up of combustion products.
- ▶ Dimensions from a flue terminal to a fanned air inlet to be determined by the ventilation equipment manufacturer.

4 INSTALLATION



WARNING: All the previous “Pre- Installation” sections must be read and the requirements met before starting boiler or flue installation.



DANGER: Risk of explosion

- ▶ Isolate the gas supply before working on gas related components.
- ▶ Check for leaks before working on gas related components.

IMPORTANT HANDLING INSTRUCTIONS

- It is advised that two people are used to carry the carton from the van to the point of delivery.

ADDITIONAL REQUIREMENTS FOR ROOF SPACE INSTALLATION

- Unpack the boiler before going up the ladder into the loft space.
- Two sets of ladders/steps should be used.
- Two people should share the lifting of the boiler up to the loft hatch, put the boiler into the loft space, tilt and slid on its back into the loft.
- Once the appliance is removed from its packaging check the contents against the packing list.



NOTICE:

- ▶ Before installing the appliance, ensure that the system has been cleaned as explained on page 8

4.1 UNPACKING



CAUTION: LIFTING AND CARRYING

- ▶ Only lift a manageable weight, or ask for help.
- ▶ Bend your knees and keep your back straight with feet apart, when lifting or putting down heavy objects.
- ▶ DO NOT lift and twist at the same time.
- ▶ Lift and carry object close to the body.

1. Cut through the tape securing the top flaps of the carton

2. Lift out the two accessory trays.

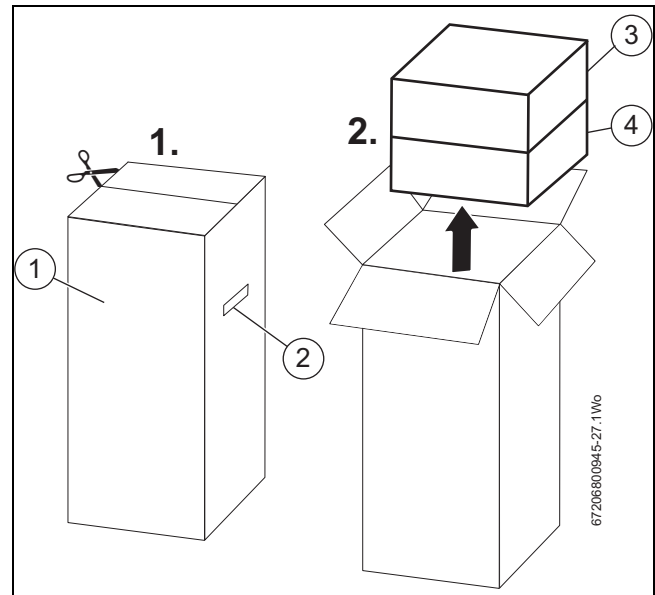

Fig. 20 Remove accessories

- [1] Outer packaging
- [2] Hand holds
- [3] Top tray
- [4] Bottom tray

3. Lay down the appliance on its back and cut through the tape securing the bottom flaps of the carton.
4. Fold the flaps back and stand the appliance up right
5. Lift the carton off the appliance.

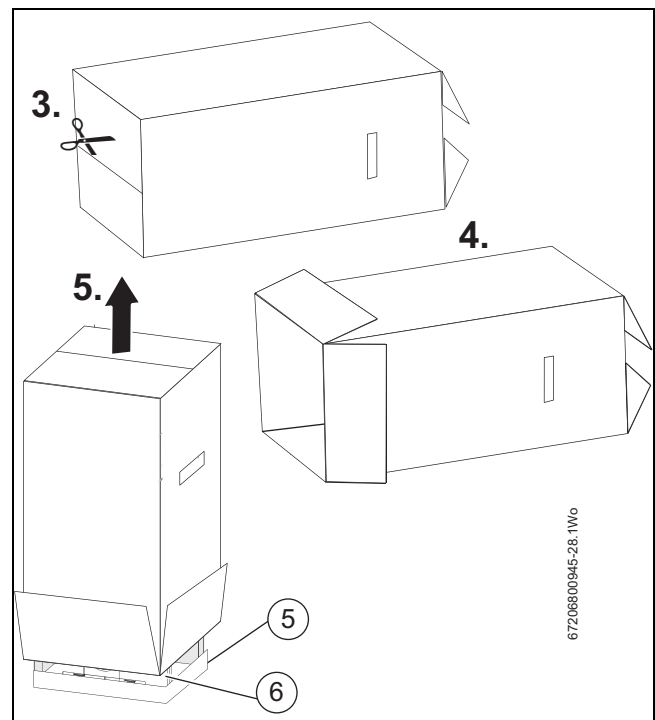

Fig. 21 Remove the carton

- [5] Appliance
- [6] Base tray

6. Remove the plastic bag covering the appliance.
7. Lay the appliance down on its back and remove the base tray.

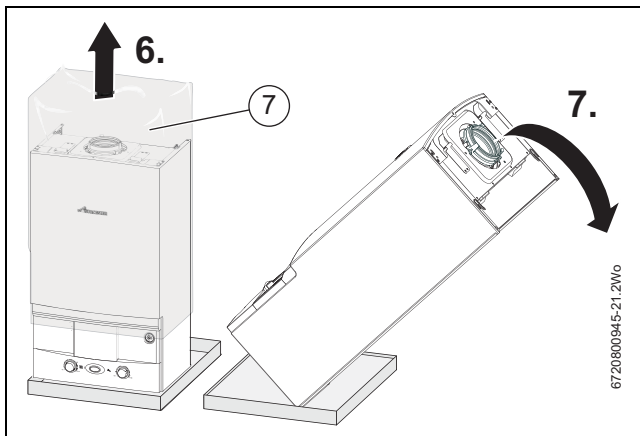

Fig. 22 Remove cover and base

Standard package contents:
Top Tray
Isolating valve bracket
Bottom Tray
Literature pack:
- Installation instructions
- User guide
- PRV installer connection
- Condensate adapter
- Wall mounting template
Hardware pack:
- Compression fittings
- Fibre washers
Top wall hanging bracket
Fascia flap

Table 13

4.2 WALL MOUNTING TEMPLATE & FLUE OPENING



WARNING: BEFORE DRILLING ENSURE THAT THERE ARE NO PIPES, ELECTRICAL CABLES, DAMP PROOF COURSES OR OTHER HAZARDS.



NOTICE: Never carry the appliance by the control box or rest the full weight of the appliance on it.

SAFETY:

All relevant safety precautions must be undertaken. Protective clothing, footwear, gloves and safety goggles must be worn as appropriate.

MOUNTING ON THE WALL

No special wall protection is required. The wall must be flat and able to bear the weight of the appliance.

- ▶ Fix the wall mounting template, supplied with the literature pack, to the wall, allowing a side clearance of at least 10 mm on each side (→ Fig. 15) .
- ▶ Drill holes for wall plugs and mounting plate to match the mounting template.
- ▶ Drill the two holes for mounting the plumbing manifold.
- ▶ If required: make a hole in wall for the flue pipe.

REAR FLUE OUTLET

The drawing opposite shows the boiler wall mounting template with the flue centre lines of both the 100mm and 125mm flue systems.

- ▶ Mark the centre line of the flue to be used (3); the external diameter of the hole can also be marked if required.
- ▶ If a 100mm diameter flue is to be used, a 125mm diameter hole is required. However, if using the weather sealing collar by pushing it through from inside the property, then a 150mm diameter hole is required to accommodate this.
 - The flue turret of the 100mm flue has an in-built 3° angle.
 - If extensions are to be added then the complete flue must rise at an angle of 3°.
- ▶ Drill the hole, preferably using a core drill.

SIDE OUTLET

- ▶ Mark from the centre line of the wall mounting template to the wall that the flue will pass through (4).
 - Allow for a rise of 52mm per metre length of flue, to give a 3° angle.
 - Clear any debris from the site.

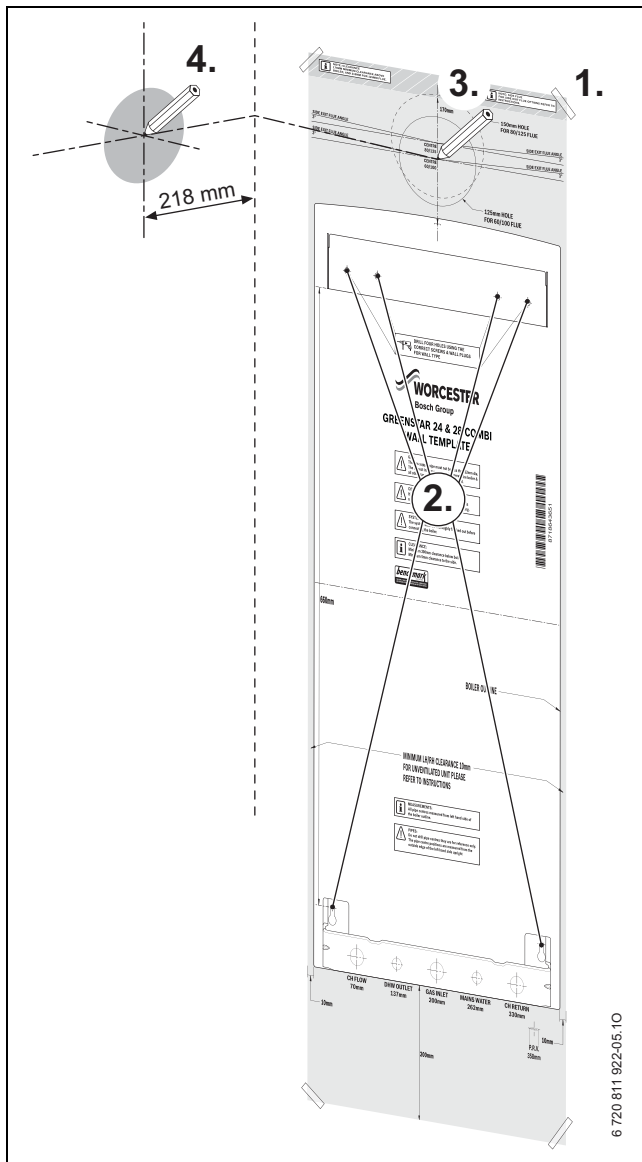

Fig. 23 Mounting template

- ▶ Remove the mounting template.
- ▶ Fit wall plugs and secure the mounting plate with appropriate fittings for the boiler weight and wall type.
- ▶ Fit the wall plugs and secure the plumbing manifold with appropriate fittings.

4.3 PRE-PLUMBING THE BOILER CONNECTIONS

NOTICE: The appliance can be damaged by debris in the pipework.

- ▶ Flush the system to remove all debris/residue.

- ▶ Remove the fittings on the connecting pipes.

GAS AND WATER CONNECTIONS - ISOLATING VALVE BRACKET

- ▶ Ensure that the fibre washers, supplied in the literature/hardware, are fitted to the connections to the isolating valves.
- ▶ Ensure that the bonded washer is fitted to the gas pipe isolating valve connection.

WARNING: Bonded washer for gas (3)

- ▶ The bonded washer must be used on the gas pipe isolating valve connection.

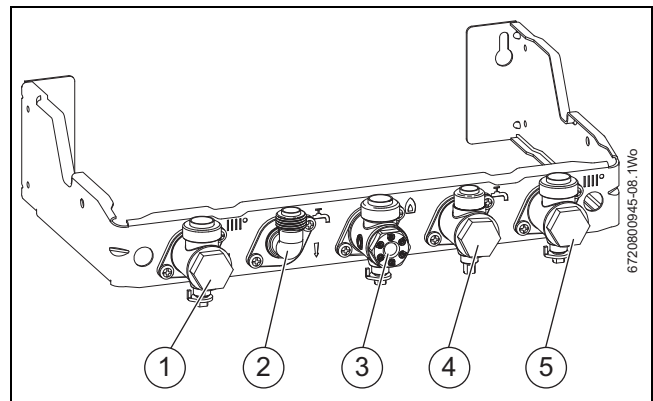

Fig. 24 Isolation valves

- [1] CH flow 22mm
- [2] DHW Outlet (15mm)
- [3] Gas inlet (22mm bonded washer)
- [4] Domestic cold water inlet (15mm)
- [5] CH return 22mm

- ▶ All pipe connections in the heating system must be suitable for a pressure of 3 bar and for 10 bar in a hot water DHW circuit.
- ▶ For filling and draining the system, fit drain valves at the lowest point of the system.
- ▶ Fit an air vent valve at the highest point.

4.4 HANGING THE BOILER

CAUTION: Lifting the boiler.

- ▶ There are two handling holes incorporated into the inner casing left and right in the lower section of the appliance.
- ▶ Do not lift the boiler using the control panel as a hand hold.

NOTICE: Hanging the boiler.

- ▶ Remove the plastic strip fitted to pipes before hanging the boiler.
- ▶ Please protect the floor from residual water.

REMOVING THE OUTER CASING

i The outer casing is secured against unauthorised removal by two screws (electrical safety).

- ▶ Always secure the outer casing with these screws.

1. Remove the two securing screws underneath the appliance.
2. Slide outer casing from the bottom forwards and lift.

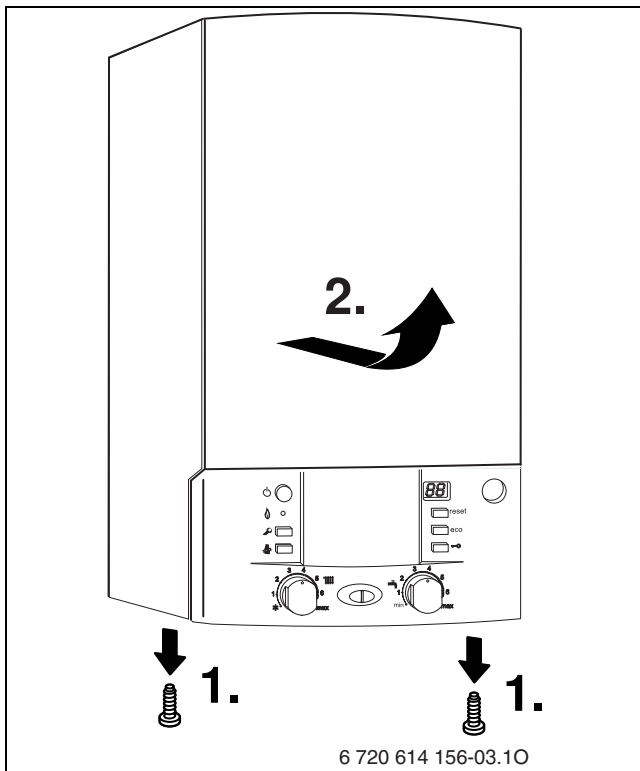

Fig. 25 Removing outer case

- ▶ Ensure that the sealing washers on the mounting plate connections.
- ▶ Locate the appliance on the top wall hanging plate.

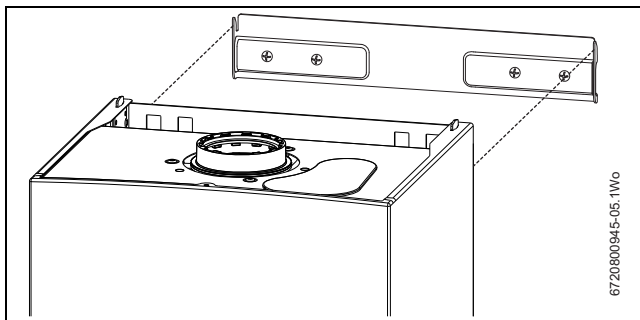

Fig. 26 Locating the appliance on the hooks

- ▶ Ensure that the gas and water connections to the isolating valves are made using the fibre washers supplied in the Literature/Hardware pack.

PRV CONNECTION

Use the supplied quick connector to connect the copper PRV pipe to the outlet pipe.

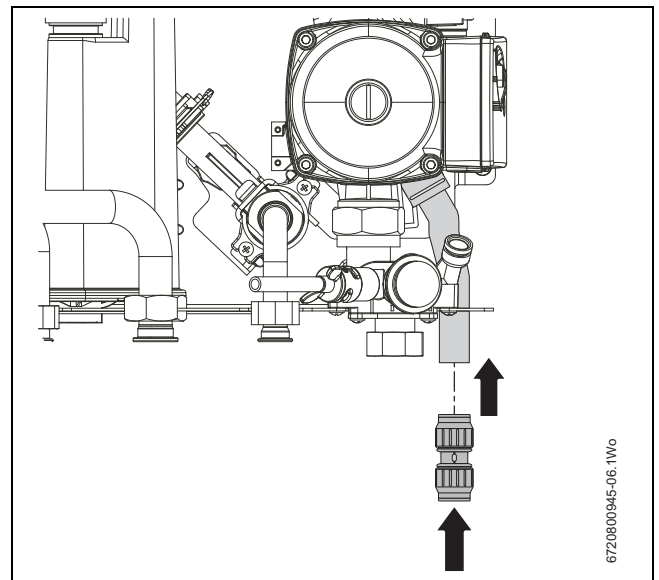

Fig. 27 PRV Connection

CONNECTING THE CONDENSATE TRAP

- ▶ Remove red blanking cap on condensate drain.
- ▶ Remove the grey condensate hose from the combustion chamber during unpacking.
- ▶ Fit the grey condensate hose onto the condensate trap and route the hose through the rear and bottom of the appliance ensuring a constant fall from the trap outlet to the pipework connection.
- ▶ Check the hose is securely fit onto the trap.
- ▶ Make connection to condensate drain pipework with adaptor (supplied in the Literature Pack).



The grey condensate hose can be reduced in length as required.

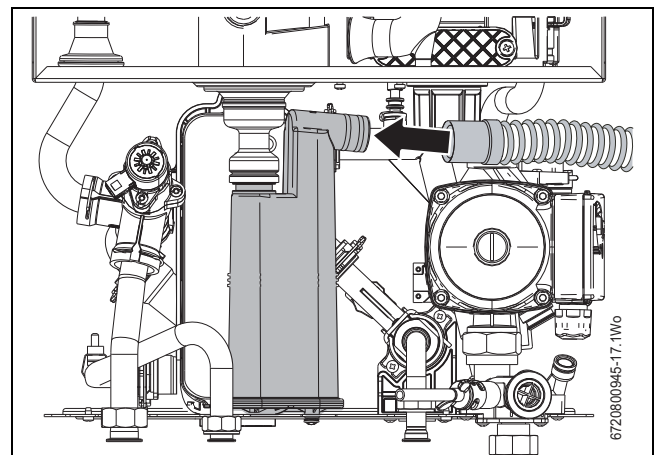

Fig. 28 Fitting the condensate hose

4.5 FLUE INSTALLATION

HORIZONTAL FLUE (60/100mm diameter)

For vertical flues and 80/125mm horizontal flues, please refer to separate instructions supplied with the flue kit.



To ease assembly of flue components, apply silicone lubricant to sealing surfaces.

Basic instructions for the 60/100mm diameter flue are shown below.

4.5.1 MEASURING THE FLUE (STANDARD FLUE):

- ▶ Measure from the outside of the wall to the centre line of the flue turret to determine length L.
- ▶ Subtract 50mm from the length L to give the correct dimension to the flue elbow connection.
- ▶ If the length L falls within the telescopic range of 350 to 570mm or 570 to 790mm using the longer telescopic flue, then no cutting will be required.
- ▶ If the required length is less than 350mm the standard telescopic flue can be modified, refer to fig. 30.
- ▶ If the required length is greater than 570mm, then the longer telescopic flue, giving a range of 570 - 790mm, can be used
- ▶ If the required length is greater than 790mm, then flue extensions will have to be used. Refer to the 60/100 Horizontal Flue Instruction manual provided in the telescopic flue kit.
- ▶ Refer to section 3.7 for flue options.

Adjusting the telescopic flue length:

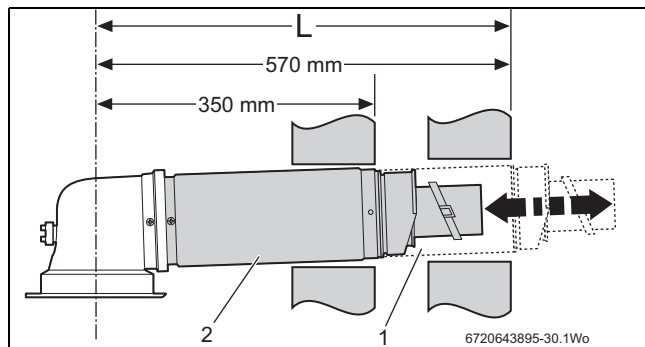

Fig. 29 Standard telescopic flue

Extend tube (1) by withdrawing from tube (2) to achieve the flue length required, between 350 - 570mm.

Secure with the screws provided and seal joint with the aluminium tape supplied.

4.5.2 REDUCING THE TELESCOPIC FLUE LENGTH:

i Ensure that the "TOP" label is facing up before securing the flue section to the turret.

The flue terminal MUST be fitted with the 'TOP' label uppermost to allow the correct fit and use of the plume management system.

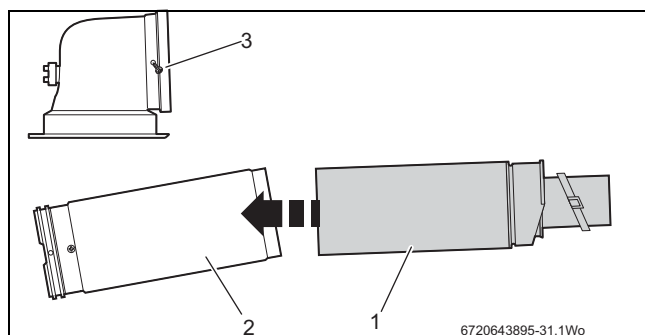

Fig. 30 Reducing the standard terminal

- ▶ Remove securing screws (3) to detach the terminal assembly from the turret.
- ▶ Slide terminal section (2) from the terminal assembly and discard.
- ▶ To use terminal (1) without cutting remove the location lug (4) on the inner flue tube (5) and remove any burrs.

To reduce the flue length further:

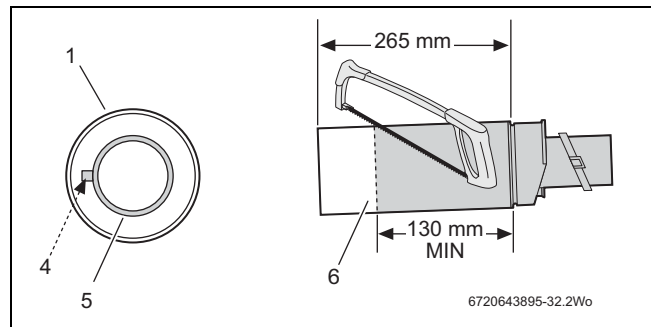

Fig. 31 Further reduction

- ▶ Mark the length required for the terminal as shown (min. 130mm) and cut square, taking care not to damage the tubes.
- ▶ Remove any burrs and chamfer the outer edge of the tubes to assist ease of connection and prevent seal damage.

i The aluminium tape is not required when reducing the terminal.

4.5.3 INSTALLING THE TELESCOPIC FLUE:

Refer to figure 32.

1. Set the flue length to the distance required, secure with screws provided.
2. Seal the joint with the aluminium tape provided.
3. Slide the inner wall seal onto the terminal.
4. If fitting from inside the building; slide the outer wall seal onto the terminal.

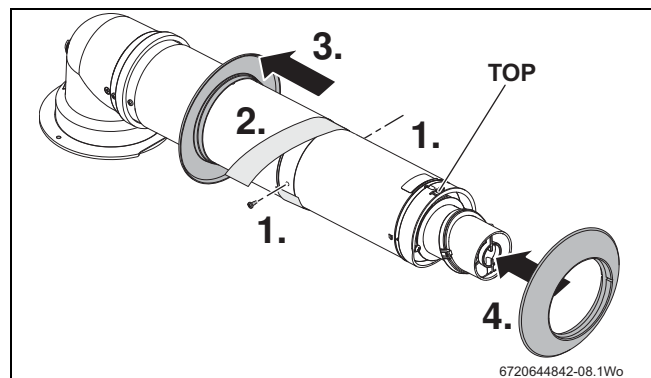

Fig. 32 Telescopic flue

i The turret securing screws are found in the boiler literature pack, not in flue kit. Do not remove the 3 flue retaining screws (1) from the flue connector. Secure the flue turret at the unused fixing points (2).

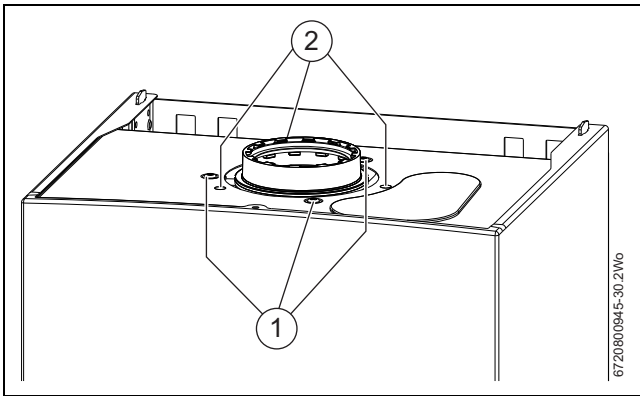

Fig. 33 Flue retaining holes

1. Use the screws provided to secure the flue turret to the appliance.
 - ▶ Fit the screws, from the literature pack to secure flue turret.
2. Check the boiler flue seal is correctly seated and apply silicone grease.
3. Position terminal through the flue opening in the wall to the outside of the building by the distance shown.
4. Align the flue turret to the boiler flue outlet with flat facing to the rear of the boiler.
 - ▶ The flue turret should be pushed straight down, on to the boiler.
 - ▶ If fitting the outer seal from outside the building, slide the outer wall seal onto the terminal as shown.

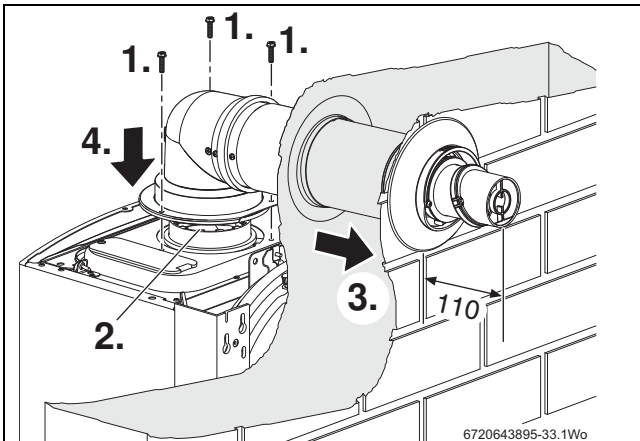

Fig. 34 Telescopic flue installation



For more information refer to the 60/100 Horizontal Flue kit Instruction Manual

ADDITIONAL NOTES AND REMINDERS:

- Ensure that all cut lengths are square and free from burrs.
- The flue is sealed when assembled correctly and the components are pushed fully home.
- The flue is set at an angle of 3° or 52mm per metre length.
- Support the flue at approximately one metre intervals and at a change of direction, use suitable brackets and fittings (Flue brackets 100mm x 6 part number: 7 716 191 173, Flue bracket 125mm part number : 7 716 191 174)

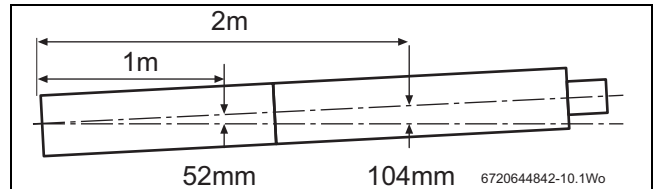

Fig. 35 Slope for condensate disposal

4.5.4 FLUE TERMINAL PLUME RE-DIRECTION:

The flue discharge can be re-directed allowing some plume redirection control, alternatively, a complete plume management system can be fitted to the flue terminal.

RE-DIRECTING THE FLUE DISCHARGE

1. Using a suitable tool, unclip (1 & 2) the terminal end and rotate through 180°.



NOTICE: DO NOT rotate the complete terminal assembly.

1. Refit to the terminal, ensuring that the clips (1 & 2) are engaged and secure.
2. Loosen screws (3) and rotate the entire outlet assembly to redirect the plume. Tighten screws (3) to secure in the required position.



The flue terminal outlet has built-in stops to limit rotation for horizontal fluing to allow condensate to run back into the boiler for safe disposal. Do not attempt to force beyond the limit stops.

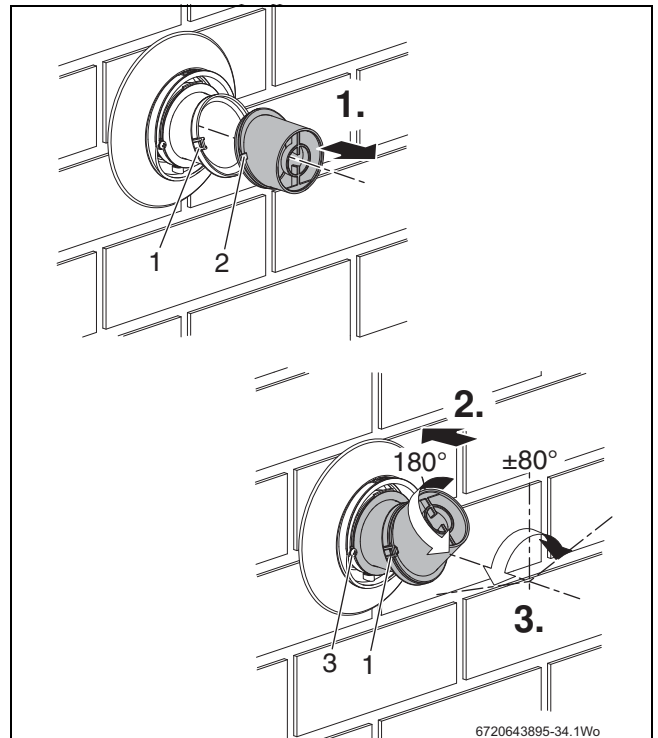

Fig. 36 Plume redirection



NOTICE: Outlet position

- ▶ The flue terminal outlet position must follow those stated in the relevant appliance instruction manual. When redirecting the flue discharge the outlet terminal must be at least 1500mm from any opening in the direction of the discharge to prevent combustion products from entering the building.

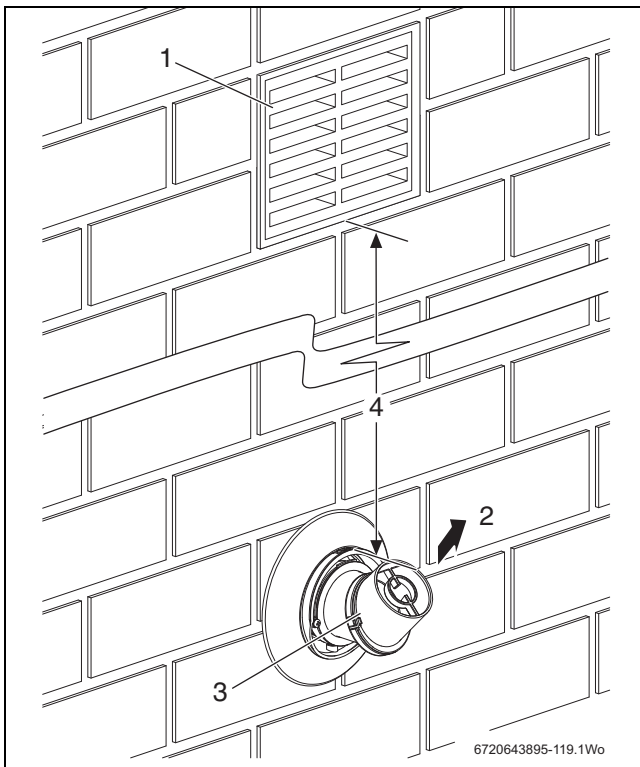

Fig. 37 Plume distance to opening

1	Opening in building
2	Flue discharge
3	Plume deflector
4	Minimum 1500mm from an opening in the building

Table 14 Key to figure 37

5 ELECTRICAL

5.1 GENERAL



CAUTION: Risk of electric shock

- ▶ Isolate the mains electrical supply before starting any work and observe all relevant safety precautions.



The boiler is pre-fitted with a mains supply cable. Route the cable through one of the holes adjacent to the flow and return valves on the isolating valve bracket, leaving some slack for movement of control panel.

FUSES

The appliance is protected by three fuses. They are located on the circuit board (→ page 27).



Replacement fuses can be found on the back of the cover (→ Fig. 39).

5.2 MAINS POWER CONNECTION

- The mains electrical supply to the boiler must be through either a fused double pole isolator or a fused three pin plug and unswitched socket situated, where practicable, adjacent to the boiler.
- The isolator must have a contact separation of 3mm minimum in both poles.
- Any additional equipment connected to the boiler must not have a separate electrical supply.
- External fuse rating 3A.

5.2.1 NEW COMPLETE SYSTEM INSTALLATIONS

If a new complete heating system installation is in a new build property or is a first time installation in an existing property, heating systems must conform to current building regulations Part L1a.

All new heating systems in dwellings must have at least two heating zones. Each of these zones will be controlled by a thermostat and zone valve.

An alternative would be individual electronically controlled TRVs. Hot water supplied from a storage system would require separate time and temperature control.

If the dwelling is over 150m², then a separate time and temperature control for each zone is required.

All radiators must have TRVs fitted in all rooms except bathrooms and rooms with room thermostats.

The exception to this are single storey, open plan dwellings where the living area is more than 70% of the total useable floor area. Then this type of dwelling can be controlled as one zone.

5.2.2 EXISTING INSTALLATIONS

For boiler replacements on an existing system, it is not necessary to zone the upstairs and downstairs separately, compliance with the zone requirements can be achieved by a single room thermostat or programmable room thermostat.

While the system is drained down, TRVs must be fitted to all rooms except the bathrooms and the room with the room thermostat.

5.3 ACCESS TO ELECTRICAL CONNECTIONS

Lower the control box into the service mode position to access all wiring connections:

- ▶ Remove the outer casing (→ page 21).

- ▶ Undo the screw and pivot the control box down.

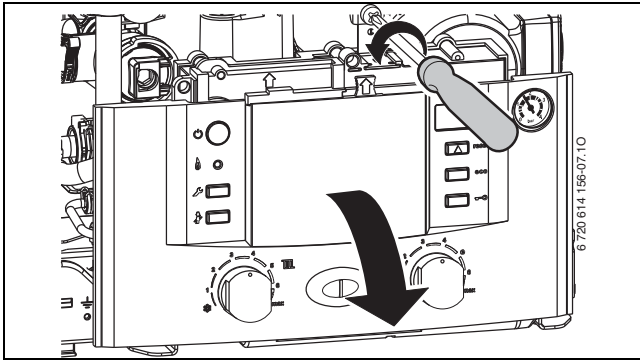

Fig. 38 Control panel to service position

- ▶ Remove screws, unhook cable and remove cover.

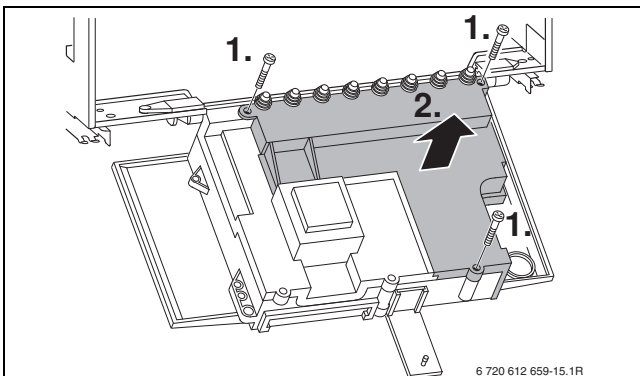

Fig. 39 Remove cover

- ▶ To provide anti-splash protection (IP), always cut cable grommet to fit cable diameter.

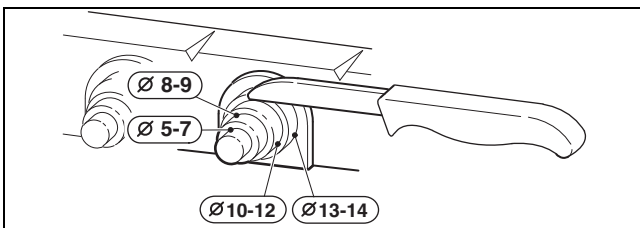

Fig. 40 Cut grommet to size

- ▶ Feed cable through cable grommet and connect as appropriate.
- ▶ Secure cable in cable grommet by means of a strain relief fitting.

5.3.1 MOUNTING OPTIONAL PLUG-IN CONTROLS

Worcester provides a range of optional plug-in controls with fitting instructions supplied with the accessories.

CONNECTING A 230 VOLT ON/OFF CONTROLLER

The controller must be suitable for mains voltage (from boiler) and must not have its own earth connection.

- ▶ Cut cable grommet to suit the cable diameter
- ▶ Feed cable through cable grommet and connect programmer to ST10 as follows:
 - L to L_S
 - S to L_R
- ▶ Secure cable in cable grommet by means of a strain relief fitting.

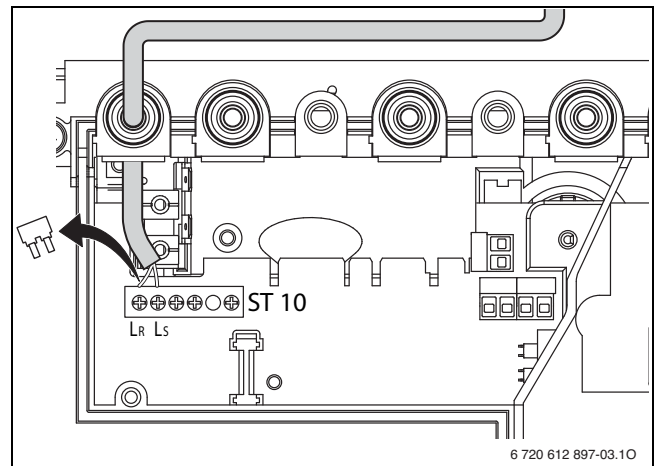

Fig. 41 Connection (230 VAC, remove jumper LS & LR)

5.3.2 NEW COMPLETE SYSTEM INSTALLATIONS

If a new complete heating system is installed in a new build property or it is a first time installation in an existing property, the heating systems must conform to current building regulations Part L1a.

All new heating systems in dwellings must have at least two heating zones. Each of these zones will be controlled by a thermostat and zone valve.

The exception to this are single storey, open plan dwellings where the living area is more than 70% of the total useable floor area. Then this type of dwelling can be controlled as one zone.

An alternative would be individual electronically controlled TRVs.

For dwellings with a floor area over 150m² a separate time and temperature control for each zone is required. All radiators must have TRVs fitted in all rooms except bathrooms and rooms with thermostats.

Figures 51 and 52 give some suggestions regarding zoning the system for a small dwelling, less than 150m² floor area, using a third party programmer or a Worcester programmer.

THIRD PARTY EXTERNAL TIMERS AND TWO ZONES

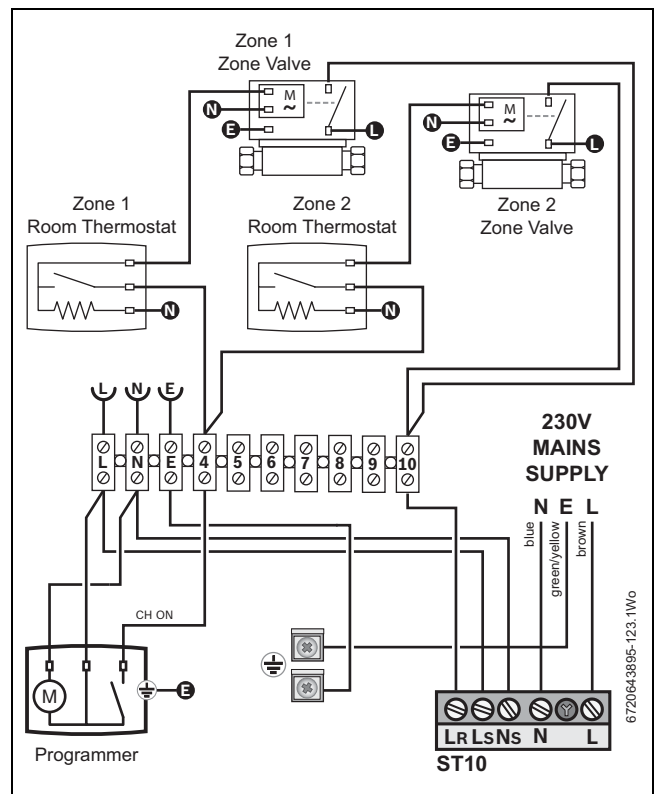

Fig. 42 Two room thermostats, one external timer

INTEGRATED TIMER AND TWO ZONES

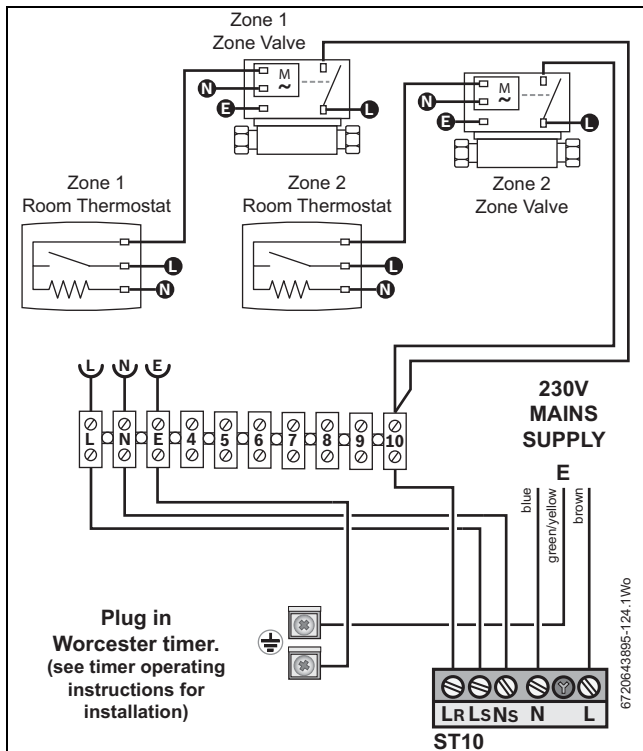

Fig. 43 Two room thermostats, one integrated timer

—L	Wire these points to	—L	this point
—N	Wire these points to	—N	this point
—E	Wire these points to	—E	this point

Table 15 Connection legend

5.3.3 EXISTING INSTALLATIONS

For boiler replacements on an existing system, it is not necessary to zone the upstairs and downstairs separately, compliance with the zone requirements can be achieved by a single room thermostat or programmable room thermostat.

While the system is drained down, TRVs must be fitted to all rooms except the bathrooms and the room with the thermostat.

The following figures show the options of room thermostat with programmer, room thermostat only or programmable thermostat.

230V ROOM STAT/CLOCK ST10

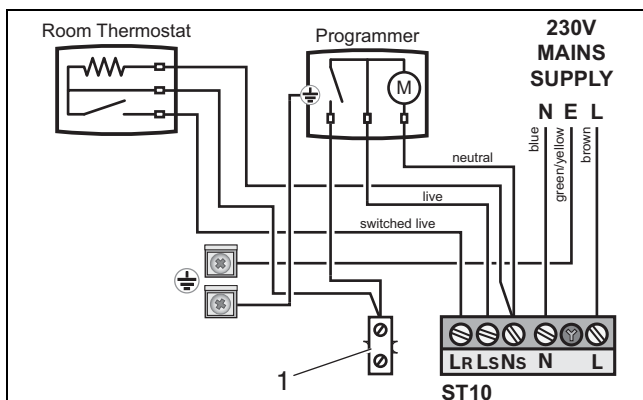
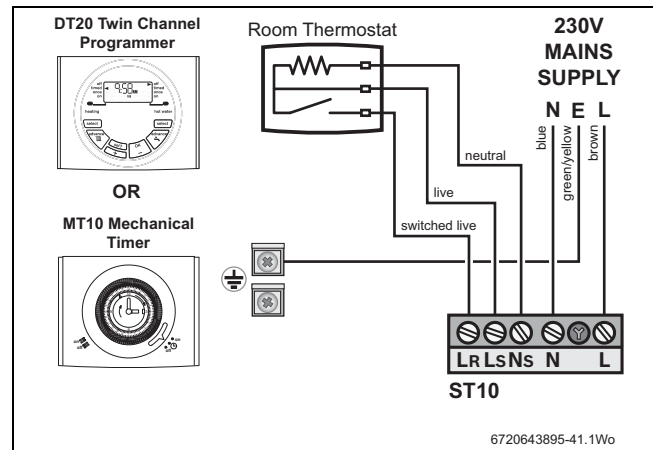

Fig. 44 Room Thermostat and programmers

1	Series connector, not supplied. Connector to be made safe.
---	---

Table 16

ROOM THERMOSTAT ONLY



PROGRAMMABLE THERMOSTAT

i The programmable thermostat may be a hard wired or RF type. This diagram is applicable for the hard wired unit and the receiver section of the RF pack.

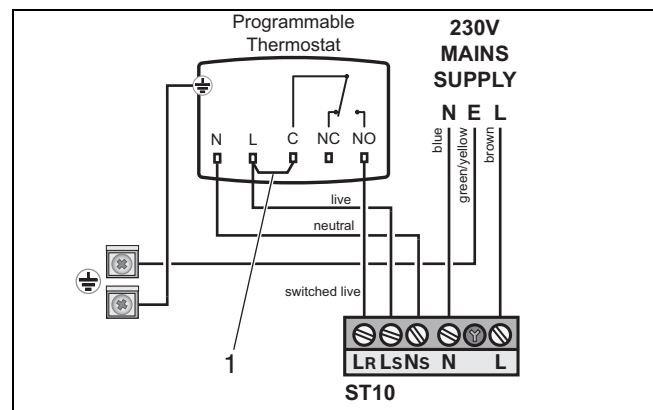

Fig. 45 Programmable thermostat

1	The link between the Live (L) and Common (C) may already be fitted as part of the Programmable thermostat, if not then a link must be wired in.
---	---

Table 17

- ▶ Remove the link between LR and LS.
- ▶ Connect external controls LIVE supply to terminal LS
- ▶ Connect external controls LIVE return to terminal LR

i 'Call for Heat' or 'Switched Live'.

- ▶ Connect external controls NEUTRAL to terminal NS

i Some devices do not require connection of a neutral i.e. battery powered devices.

5.4 ELECTRICAL WIRING DIAGRAM

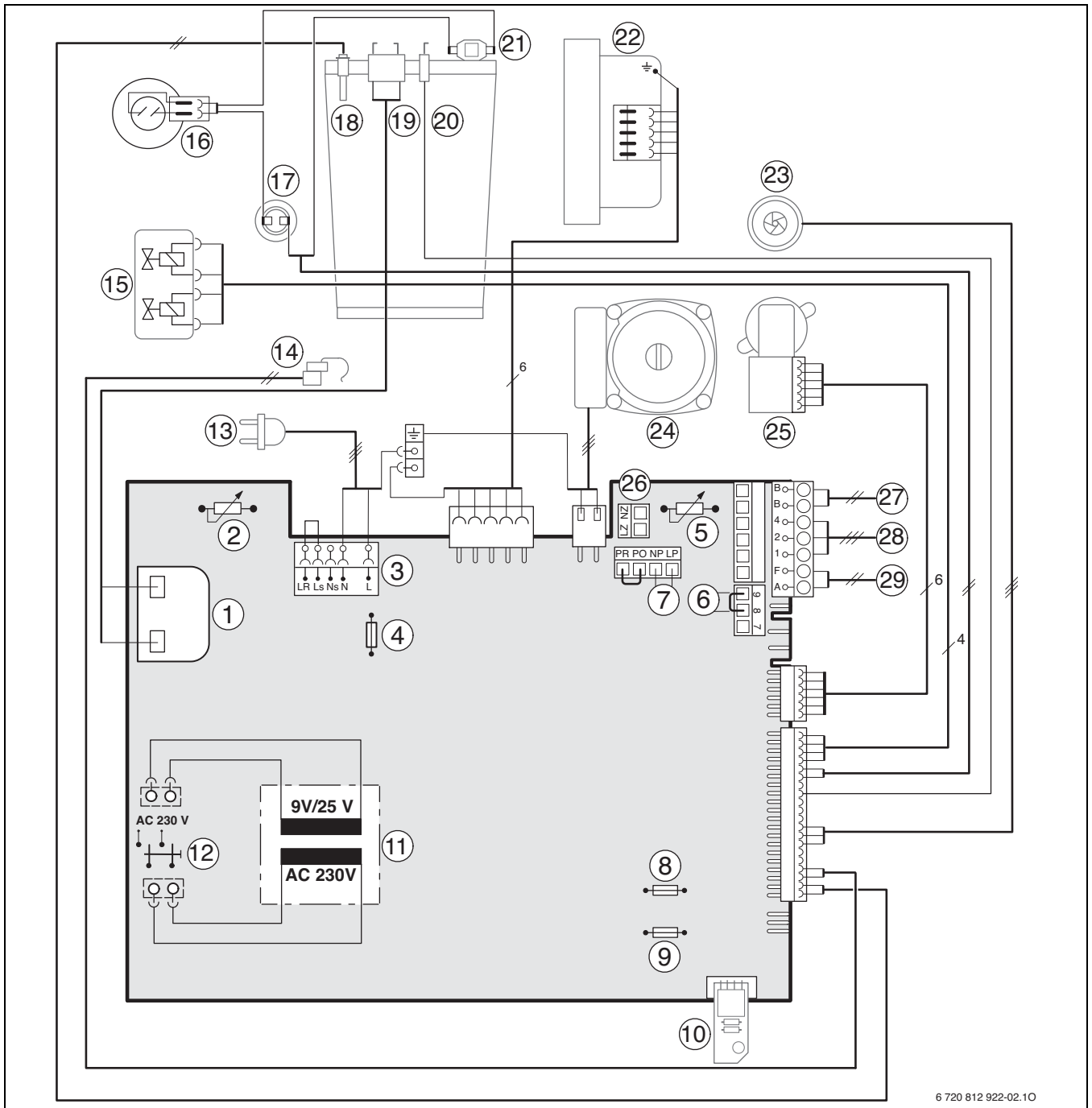

6 720 812 922-02.10

Fig. 46

- | | |
|---|--|
| <ul style="list-style-type: none"> [1] Ignition transformer [2] Flow temperature control [3] Terminal strip, 230 V AC [4] Fuse, 2.5 A slow (230 V AC) [5] Temperature control for hot water [6] Connection for temperature limiter TB1 (24 V DC) [7] DHW circulation pump connection, or external heating circuit pump in a consumer circuit w/o mixer (secondary circuit) Select service function 5.E [8] Fuse, 0.5 A slow (5 V DC) [9] Fuse, 1.6 A slow (24 V DC) [10] Code plug [11] Transformer [12] Main switch [13] Connecting lead with plug [14] DHW temperature sensor [15] Gas valve | <ul style="list-style-type: none"> [16] Air pressure switch (30 kW only) [17] Flue gas temperature limiter [18] Temperature sensor, CH flow [19] Ignition electrode [20] Flame monitoring electrode [21] Temperature limiter for heating block [22] Fan [23] Flow turbine [24] Central heating pump [25] 3-way valve [26] Connection for external heating pump (primary circuit) Select service function 1.E, → page 35 [27] Connection for BUS device, e.g. FW100, FR110 [28] Connection for low voltage/volt free connections, → page 33 for more information [29] Connection for outside temperature sensor |
|---|--|

6 COMMISSIONING

6.1 PRE-COMMISSIONING CHECKS



CAUTION: Isolate the mains electricity supply before starting any work and observe all relevant safety precautions.

Check that the service and water pipes are connected to the correct positions on the manifold.

Ensure that the washers have been fitted to the water connections and the bonded washer to the gas connection on the manifold, refer to Fig. 26.

1. CH flow (22mm)
 2. DHW (15mm)
 3. Gas inlet - bonded washer (22mm)
 4. Domestic Cold Water in (15mm)
 5. CH return (22mm)
- ▶ Check the gas type specified on the data label, on the right hand side of the combustion chamber, matches that of the gas supply.
 - ▶ Turn on the main gas supply, carry out a tightness test on the gas pipe work with the boiler gas isolating pipe valve open, and connections. Rectify any leaks.
 - ▶ Check that the condensate pipe has been connected and correctly fitted to the condensate trap.
 - ▶ Check pressure relief drain pipe is correctly fitted and securely tightened.



NOTICE: If the boiler is not to be commissioned immediately then, after successfully completing all of the checks and any rectification work:

- ▶ Close the gas valve
- ▶ Close the water shut off valve
- ▶ Isolate the gas supply
- ▶ Isolate the electricity supply
- ▶ Label appropriately

6.2 FILLING THE SYSTEM

- ▶ Turn on the water main and open the system valves.
- ▶ Open all radiator valves.
- ▶ Fill the system via a WRAS approved filling loop to 1 bar then close the filling loop valve(s).
- ▶ The Automatic Air Vent will release any air trapped in the boiler.
- ▶ Manually vent all radiators, tighten when completed and check the system and correct any leaks.
- ▶ The boiler integral expansion vessel is pre-charged to 0.75 bar (equal to a static head of 7.5m (22ft)). A Schraeder type valve is fitted to the expansion vessel to allow for pressure adjustment if required.
- ▶ If an extra expansion vessel is fitted to the central heating return, adjust this to the same pressure as the appliance internal expansion vessel, refer to separate instructions with the extra expansion vessel.
- ▶ If required increase system pressure back to 1 bar.
- ▶ Isolate and remove filling loop connection to system.

6.3 WATER TREATMENT



NOTICE: Artificially softened water must not be used to fill the central heating system.

ENSURE THAT THE SYSTEM HAS BEEN CLEANED. REFER TO SECTION 3.1 OF THESE INSTRUCTIONS.

FLUSHING (Central Heating)

- ▶ Ensure the boiler is switched off.
- ▶ Open all drain cocks and drain the system while the boiler is hot.
- ▶ Close drain cocks and add a suitable flushing agent at the correct strength for the system condition in accordance with the manufacturer's instructions.
- ▶ Run the boiler/system at normal operating temperature for the time stated by the manufacturer of the flushing agent.
- ▶ Drain and thoroughly flush the system to remove the flushing agent and debris.

INHIBITOR (Central Heating)

- ▶ Check drain cocks are closed and all radiator valves are open before adding a suitable inhibitor compatible with aluminium (or combined inhibitor/anti-freeze if the system is exposed to freezing conditions) to the heating system water in accordance with the manufacturers instructions.



The pH value of the system water must be less than 8 or the appliance guarantee will be invalidated.

- ▶ Fill system via a WRAS approved filling loop to between 1 and 1.5 bar.
- ▶ Vent all radiators; tighten vents when complete.
- ▶ Re-pressurise if necessary to 1bar.
- ▶ Set all controls to maximum.
- ▶ Record the date when the inhibitor was added to the system on the guarantee card and Benchmark checklist.



NOTICE:

- ▶ The concentration of inhibitor in the system should be checked every 12 months or sooner if system content is lost.

WATER TREATMENT

Suitable water treatment products can be obtained from the following manufacturers:

FERNOX	01799 550811 www.fernox.com
SENTINEL	0800 389 4670 www.sentinel-solutions.net

Table 18

6.4 STARTING THE APPLIANCE



CAUTION: RUNNING THE APPLIANCE

▶ Never run the appliance when the appliance/system is empty or partially filled.

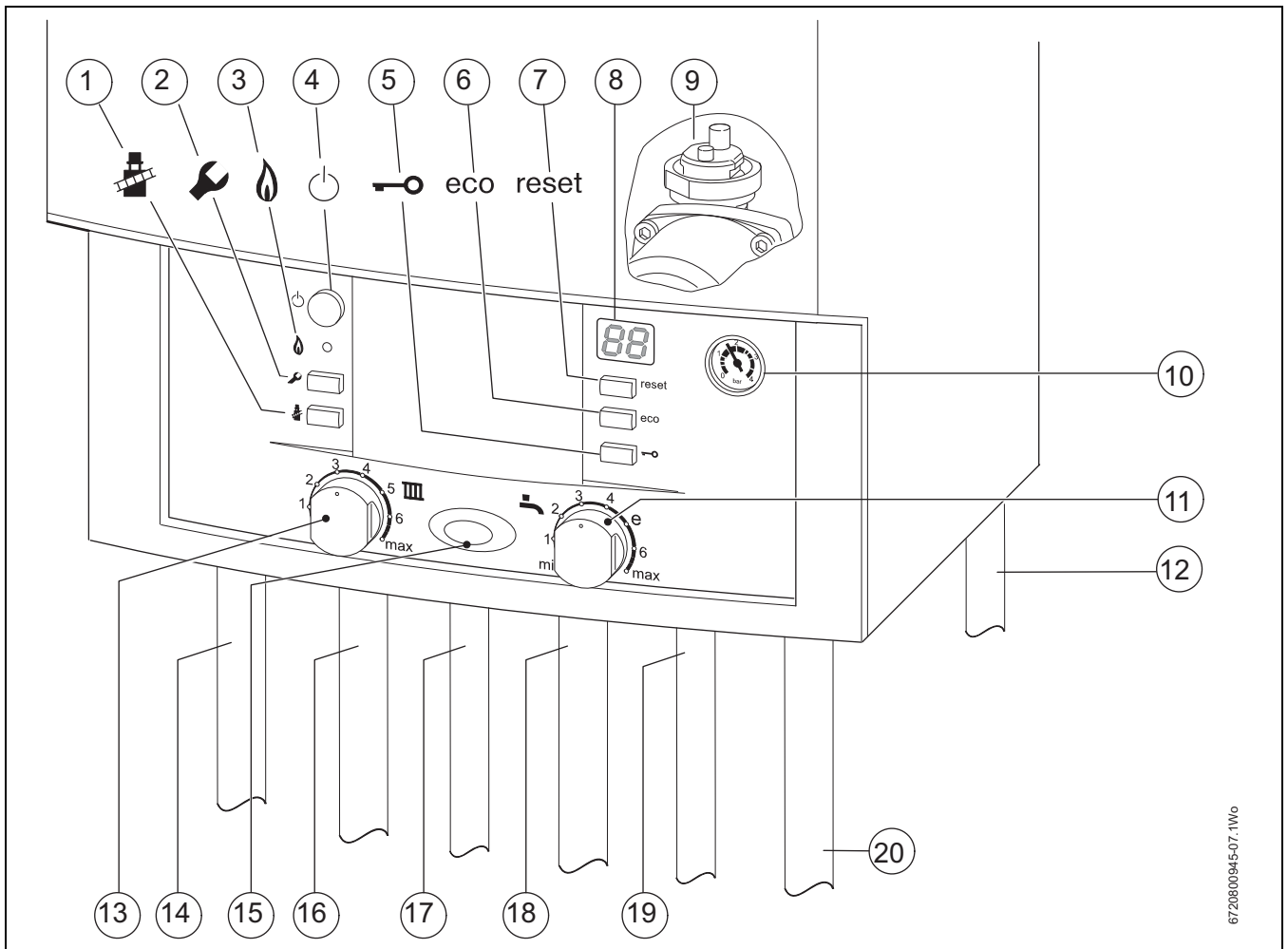

6720800945-07-1W6

Fig. 47

- [1] Performance test button
- [2] Service button
- [3] Burner ON/OFF indicator light (green)
- [4] ON/OFF button
- [5] Key lock
- [6] Eco button
- [7] Fault reset button
- [8] Display
- [9] Auto air vent
- [10] System pressure gauge
- [11] DHW temperature control
- [12] PRV drain
- [13] CH temperature control
- [14] CH flow
- [15] Mains ON/OFF indicator/diagnostic light (blue)
- [16] DHW outlet
- [17] Gas
- [18] DCW in
- [19] CH return
- [20] Condensate



NOTICE: RESET

▶ Do not press the blue Mains ON/OFF indicator [15] to reset the boiler.

▶ To reset the boiler, press the RESET button [7]

6.5 SWITCHING THE APPLIANCE ON/OFF

SWITCHING ON

- ▶ Switch appliance on at the ON/OFF switch. The display indicates the current heating water flow temperature. The indicator for burner operation/faults is permanently on, as long as the burner is operational.

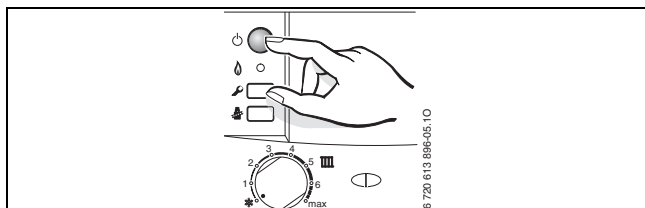

Fig. 48

- i** When the appliance is switched on for the first time, it performs a once-only venting sequence. This involves the heating circuit pump switching on and off at intervals (for a period of approx. 4 minutes). The display shows alternating with the flow temperature.

- ▶ Open the automatic air vent valve [9] and close it again when the venting sequence has finished (→ page 29).

- i** The syphon filling function is active if the display shows alternating with the flow temperature, (→ page 36).

SWITCHING OFF THE APPLIANCE

- ▶ Switch appliance off at the ON/OFF switch. The display goes blank.
- ▶ If the appliance is to be switched off for a longer period of time: observe correct frost protection procedures (→ Section 6.13).

6.6 STARTING THE CENTRAL HEATING

The maximum flow temperature can be set to between 35 °C and approx. 90 °C .

- i** With underfloor heating systems, take care to observe the maximum permissible CH flow temperatures.

- ▶ Turn CH flow temperature control to adjust the maximum CH flow temperature according to the central heating system:
 - Underfloor heating: e.g. position **3** (approx. 50 °C)
 - Low temperature heating system: position **6** (approx. 75 °C)
 - Heating system for flow temperatures up to 90 °C: **max** position

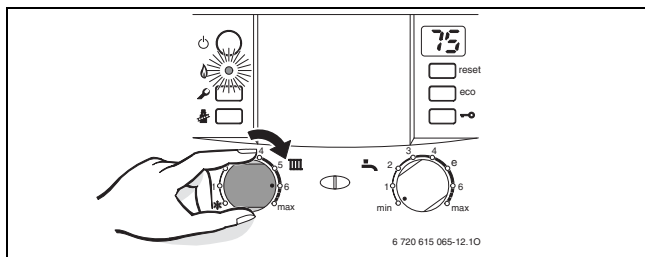

Fig. 49

When the burner is alight, the green lamp for burner operation lights up.

Position	CH flow temperature
1	Approx. 35 °C
2	Approx. 43 °C
3	Approx. 50 °C
4	Approx. 60 °C
5	Approx. 67 °C
6	Approx. 75 °C
max	Approx. 90 °C

Table 19

6.7 SETTING LOW NOx HEATING OUTPUT

Refer to section 7.3.1 on page 35 to adjust the Central Heating output down from the maximum of 76%.

Enter parameter 53 (53%) and save to set the boiler to low NOx output.

Parameter 53 equates to 53% of the full boiler output which is approximately 14.15 kW.

6.8 HEATING CONTROL

- i** Follow the operating instructions for the optional programmer / timer used. Those instructions will tell you how to:
 - ▶ set the operating mode and the heating curve for weather-dependent controllers,
 - ▶ adjust the room temperature,
 - ▶ heat economically and save energy.

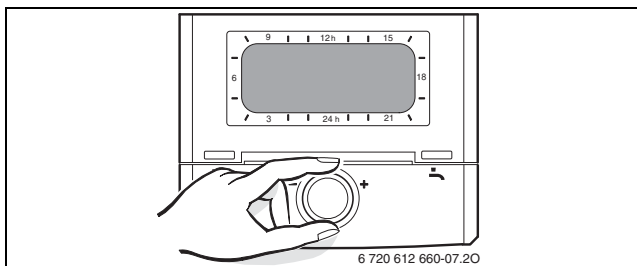

Fig. 50

6.9 CO AND COMBUSTION CHECKS

The following combustion and flue integrity checks will be mandatory from April 2014 and these values must be recorded on the Benchmark check list, at the back of this manual.

Once the gas rate and pressure have been confirmed as acceptable, then the CO and combustion checks can be undertaken.

The flow chart is given for guidance; the details of the checks are given in the following sections:

- Checking flue integrity, refer to section 8.2, page 38.
- Setting the air/gas ratio, refer to section 8.5, page 39.

NOTICE: BEFORE CO AND COMBUSTION CHECKS:

- ▶ Refer to chapter 8 to verify gas type, gas inlet pressure, and gas rate. Visually check the integrity of the whole flue system and confirm that all the components are correctly assembled, fixed and supported.
- ▶ The flue gas analyser must be the correct type as specified in BS 7967. Before use the analyser must have been calibrated as specified by the manufacturer. The installer must be competent in the use of the analyser. Check and zero the analyser in fresh air as specified by the manufacturer.
- ▶ The air/gas ratio valve is factory set and must not be adjusted during commissioning unless this action is recommended following contact with the Worcester, Bosch Group help line 0330 123 3366.

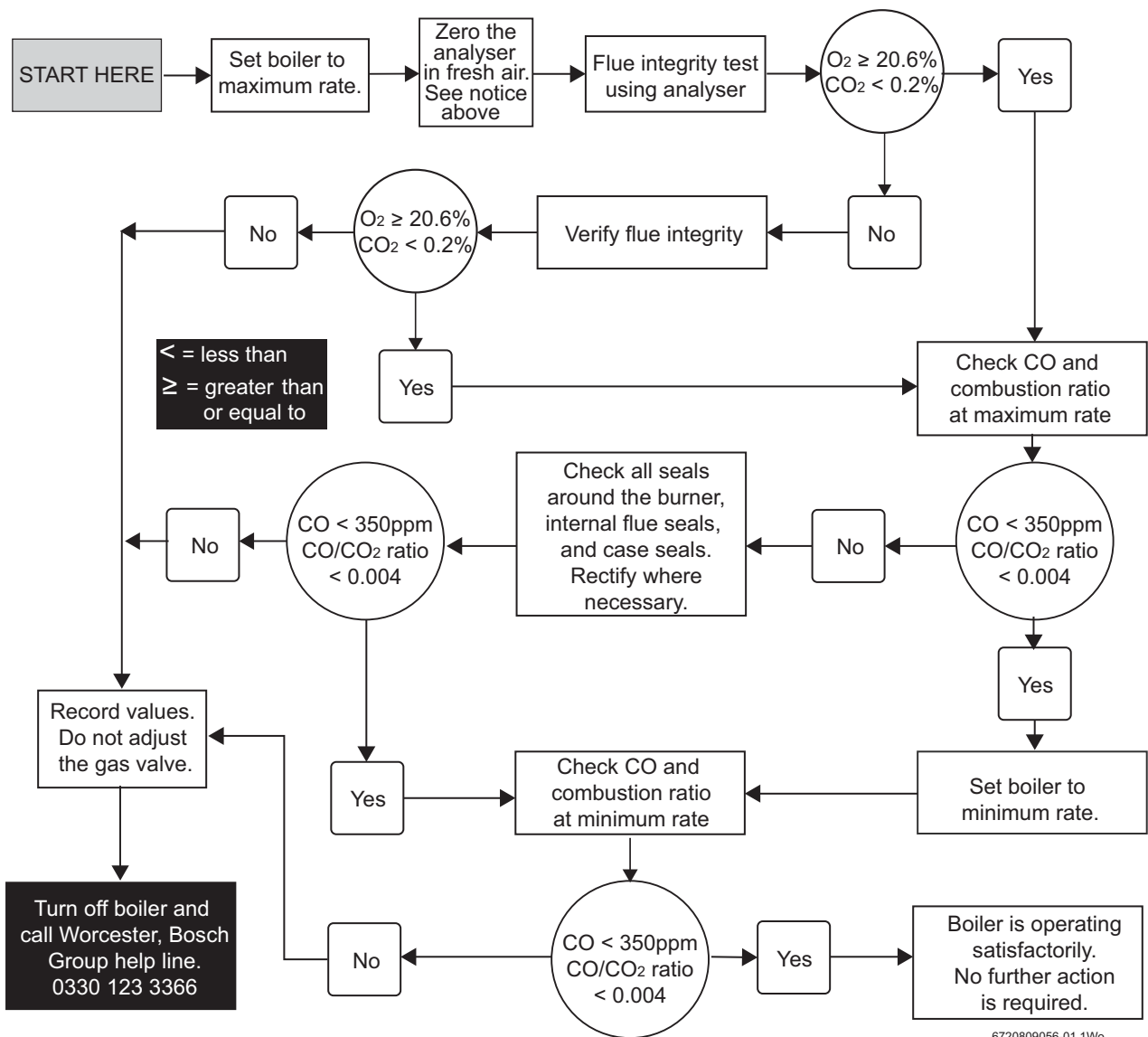

Fig. 51 Combustion check flow chart

6.10 FINISHING COMMISSIONING

- ▶ Check the gas inlet pressure (→ page 38).
- ▶ Check that condensate is being discharged from the condensate hose. If that is not the case, switch the ON/OFF switch off and on again. That activates the syphon filling function (→ page 36). Repeat the procedure several times until condensate starts running out.

- ▶ Record the settings in the Benchmark Commissioning checklist at the back of this manual.

FITTING THE FASCIA FLAP

- ▶ Check the orientation of dampers [1] (→ Fig. 52).
- ▶ Click the flap into place from below.

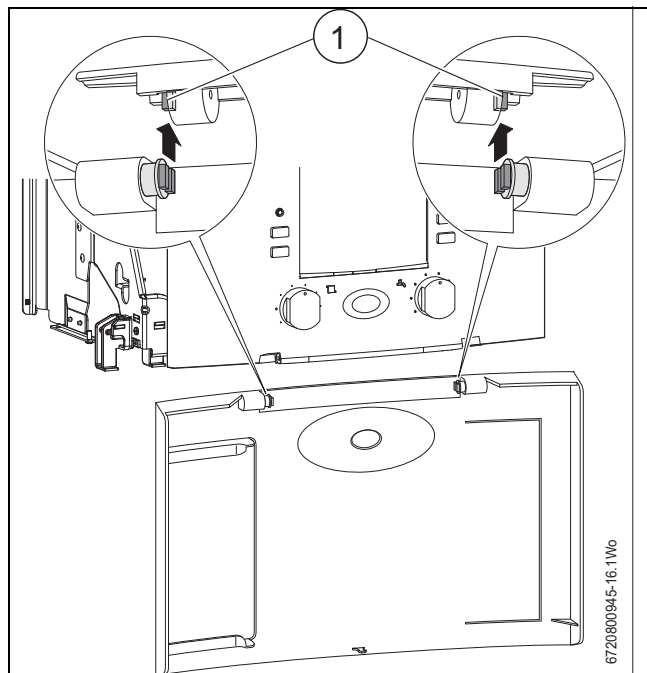

Fig. 52 Fitting the flap

- ▶ Close the flap. The flap locks into place.
- ▶ To open the flap, push in the upper middle part of the flap and release it. The flap will then open.

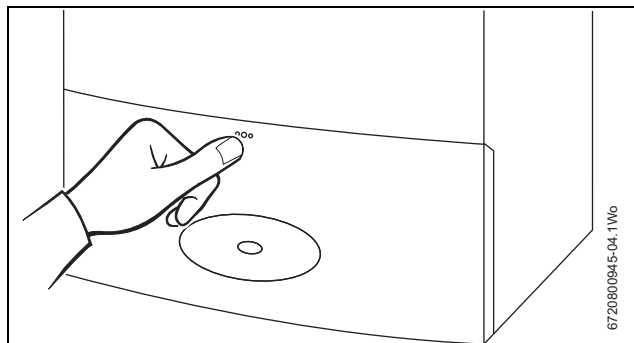

Fig. 53 Opening the flap

6.11 SETTING THE DHW TEMPERATURE

- ▶ Set the DHW temperature on the DHW temperature control . The set DHW temperature flashes on the display for 30 seconds.

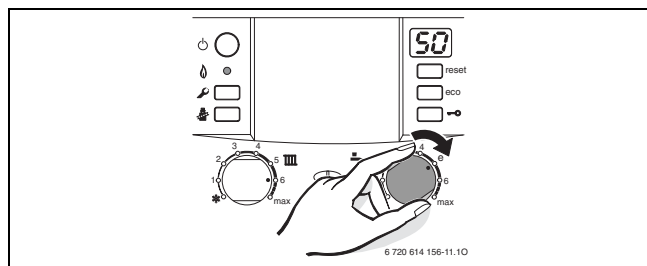

Fig. 54

DHW thermostat	DHW temperature
min	Approx. 40 °C
e	Approx. 50 °C
max	Approx. 60 °C

Table 20

ECO KEY

Holding down the eco key until it illuminates switches between **Comfort mode** and **Economy mode**.

COMFORT MODE, ECO KEY IS NOT LIT (DEFAULT SETTING)

The appliance is held **constantly** at the set temperature. This means that hot water is available almost instantaneously at the tap. Consequently the appliance will switch on at intervals, even if no hot water is being drawn.

ECONOMY MODE, ECO KEY LIT

The appliance does not switch on until the start delay has elapsed if a start delay has been set (service function b.F).

- DHW is not heated up until a hot water tap is turned on.
- **Signalling demand.** Briefly turning a hot water tap on and then off signals demand so that the water is then heated up to the set temperature.

Signalling demand enables maximum gas and water economy.

6.12 SUMMER MODE (CENTRAL HEATING OFF, DHW ONLY)

- ▶ Note position of CH flow temperature control .
- ▶ Turn CH flow temperature control anti-clockwise as far as the stop . The heating circuit pump and consequently central heating are switched OFF. However, the DHW supply as well as the power supply to the heating controller and timer remain "live".

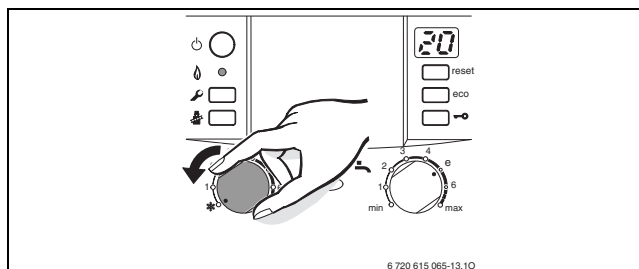

NOTICE: Risk of heating system freezing.

Additional instructions are contained in the operating instructions for the heating controller.

6.13 FROST PROTECTION

Frost protection for the heating system:

- ▶ Leave appliance switched on, set CH flow temperature control  to position 1 at least.

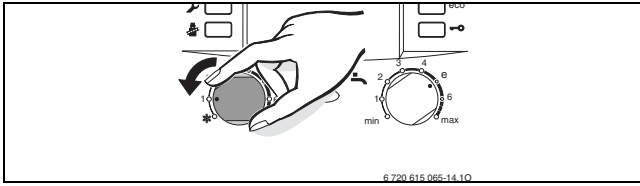



Fig. 55 Frost protection

- ▶ Add a suitable inhibitor with anti-freeze to the central heating system water (→ page 8) and drain the DHW system.

Additional instructions are contained in the operating instructions for the heating controller.

Frost protection for hot water cylinder:

- ▶ Turn the temperature control for hot water  anti-clockwise as far as the stop.

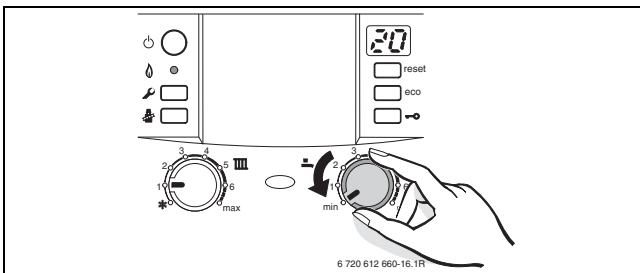



Fig. 56

6.14 BUTTON LOCK

The button lock affects the CH flow temperature control, the hot water temperature control and all buttons except the main switch and the reset button, chimney sweep button.

To activate the button lock:

- ▶ Press key until  and the heating flow temperature are shown alternately on the display.

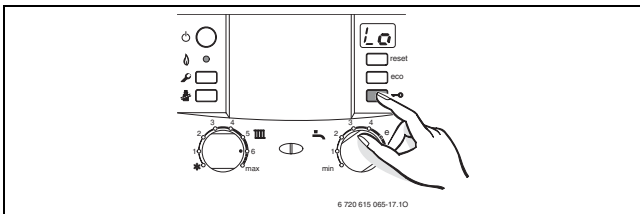

Fig. 57 Button lock

To deactivate the button lock:

- ▶ Hold down the key until the display shows only the CH flow temperature.

7 SETTING THE CONTROL PANEL

7.1 GENERAL

The Control unit provides the capability to adjust and check of many appliance functions.

For an overview of the service functions see chapter 7.2

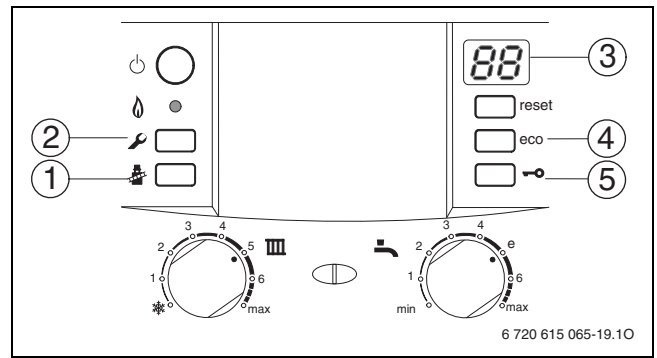





Fig. 58 Overview of the controls

- [1] Central Heating boost button
- [2] Service key
- [3] Display
- [4] eco key, service functions "up"
- [5] Key lock, service functions "down"

SELECTING A SERVICE FUNCTION



The service functions are subdivided into two levels (→ tables 21 and 22 on page 34).

- ▶ Hold down the service key  until it illuminates. The display shows a code such as 1.A (service level 1).
- ▶ Press eco key and key lock simultaneously until a code such as 8.A appears (service level 2).
- ▶ Press key lock or eco key until the required service function is displayed.
- ▶ Press and release the Central Heating boost button . The Central Heating boost button  illuminates and the display shows the parameter for the selected service function.

ADJUSTING A VALUE

- ▶ Press key lock or eco key until the required service function value is displayed.
- ▶ Enter the value on the "Control unit settings" label supplied and affix the label in a clearly visible position on the appliance.



SAVING A VALUE

- ▶ Hold down the Central Heating boost button  until the display shows .



The unit automatically exits the service level if no key is pressed for 15 minutes.

EXITING THE SERVICE FUNCTION WITHOUT SAVING VALUES

- ▶ Briefly press the Central Heating boost button . The light in the Central Heating boost button  will extinguish.

RESETTING THE APPLIANCE

- ▶ Press reset for 3 seconds and release. When the key is released, the appliance restarts without resetting parameters (→parameter reset).

RESTORING VALUES TO STANDARD SETTING

To restore all values on service levels 1 and 2 to their standard settings:

- ▶ On service level 2, select service function 8.E and save value **00**. The appliance starts with the standard setting.

7.2 SERVICE FUNCTIONS OVERVIEW

7.2.1 SERVICE LEVEL 1 (PRESS SERVICE KEY UNTIL ILLUMINATED)

Display	Service function	Page
1.A	Maximum heating output	35
1.b	Not applicable in the UK	-
1.E	Pump control mode	35
1.F	Not applicable in the UK	-
2.b	Maximum flow temperature	35
2.C	Venting function	35
2.d	Thermal disinfection	35
2.F	Operating mode	35
3.A	Automatic cycle block	35
3.b	Cycle block	35
3.C	Switching differential	36
3.E	Cycle time, keeping DHW hot	36
3.F	Anti recycle time after DHW demand	36
4.b	Maximum temperature for keeping the heat exchanger hot	36
4.d	Not applicable in the UK	-
4.E	Appliance type	36
4.F	Condensate trap filling sequence	36
5.A	Reset inspection interval	36
5.b	Fan run-on time	36
5.C	Timer channel setting	36
5.d	Not applicable in the UK	-
5.E	Connection NP - LP	36
5.F	Set inspection interval	36
6.A	Last fault	36
6.b	Room temperature controller, actual voltage, terminal 2	36
6.C	Flow temperature required by weather-compensated controller	36
6.d	Current throughput, flow meter	36
6.E	Time switch input	36
7.A	Indicator for burner operation/faults	37
7.b	3-way diverter valve in centre position	37
7.C	Min. DHW volume	37
7.D	Not applicable in the UK	-
7.E	Building drying function	33
7.F	Room temperature controller, configuration of terminals 1-2-4	37

Table 21 Service functions, level 1

7.2.2 SERVICE LEVEL 2: ACCESSED FROM SERVICE LEVEL 1; SERVICE KEY ILLUMINATES (PRESS ECO KEY AND KEY LOCK SIMULTANEOUSLY UNTIL A CODE SUCH AS 8.A APPEARS)

Service function	Display	Page
8.A	Software version	37
8.b	Code plug number	37
8.C	GFA status	37
8.d	GFA fault	37
8.E	Reset all parameters	37
8.F	Permanent ignition	37
9.A	Permanent operating mode	37
9.b	Current fan speed	37
9.C	Current heating output	37
9.E	Flow turbine signal delay	37
9.F	Heating circuit pump run-on time	37
A.A	Temperature at flow	37
A.b	DHW temperature	37
A.C	Not applicable in the UK	-
b.A	Not applicable in the UK	-
b.F	Start delay	38

Table 22 Service functions, level 2

7.3 DESCRIPTION OF SERVICE FUNCTIONS

7.3.1 SERVICE LEVEL 1

SERVICE FUNCTION 1.A: HEATING OUTPUT

The heating output in percent can be limited between the minimum and maximum rated output to suit the specific heat demand.



Even if the heating output has been limited, the maximum rated output is still available for DHW heating.

Standard setting is maximum rated output:

Appliance type	Display indication
28 ...	76

Table 23

To change the heating output between the minimum of 33% to the maximum of 76%:

- ▶ Select service function 1.A.
- ▶ Enter the required parameter.
- ▶ Save the parameter.
- ▶ Enter heating output in kW and display information in the Benchmark commissioning checklist at the back of this manual.
- ▶ Exit the service functions.
The display shows the flow temperature again.

SERVICE FUNCTION 1.E: PUMP CONTROL MODE FOR HEATING OPERATION



If an outside temperature sensor for a weather-compensated controller is connected, pump control mode 04 is automatically set.

- **Pump control mode 00 (automatic mode, standard setting):**
The BUS controller regulates the heating circuit pump.
- **Pump control mode 01:**
For heating systems without controller.
The flow temperature is used to regulate the heating circuit pump. When there is a heat demand, the heating circuit pump and the burner start.
- **Pump control mode 02:**
For heating systems with room temperature controller connected to 1, 2, 4 (24 V).
- **Pump control mode 03:**
The heating circuit pump runs continuously (exceptions: see heating controller operating instructions).
- **Pump control mode 04:**
Intelligent control of heating circuit pump in heating systems with weather-compensated controller. The heating circuit pump is only switched on when required

SERVICE FUNCTION 2.B: MAXIMUM FLOW TEMPERATURE

The maximum flow temperature can be set to between 35 °C and 88 °C.

Standard setting is **88**.

SERVICE FUNCTIONS 2.C: VENTING FUNCTION



When the appliance is switched on for the first time, it performs a once-only venting sequence. This involves the heating circuit pump switching on and off at intervals (for approx. 4 minutes).
The display shows alternating with the flow temperature.



The venting function can be activated after maintenance.

The following settings are possible:

- **00:** Venting function off
- **01:** Venting function is switched on and after completion automatically reset to **00**.
- **02:** Venting function is permanently on and is not reset to **00**.

Standard setting is **01**.

SERVICE FUNCTION 2.D: THERMAL DISINFECTION



WARNING: Risk of scalding!

Hot water can lead to severe scalding.

- ▶ Only carry out thermal disinfection outside normal hours of use.

The following settings are possible:

- **00:** Thermal disinfection disabled
- **01:** Thermal disinfection enabled

Standard setting is **00** (disabled).

THERMAL DISINFECTION:



WARNING: Risk of scalding!

- ▶ Disable this service function after thermal disinfection.

If this service function is enabled, DHW is **permanently** heated to approx. 75 °C if the DHW temperature controller has been turned fully clockwise.

SERVICE FUNCTION 2.F: OPERATING MODE

With this service function, you can temporarily change the appliance operating mode.

The following settings are possible:

- **00:** Standard operation; the appliance runs according to controller specifications.
- **01:** The appliance runs for 15 minutes at minimum output. The display shows the flow temperature alternating with . After 15 minutes the appliance reverts to standard operating mode.
- **02:** The appliance runs for 15 minutes at maximum output. The display shows the flow temperature alternating with . After 15 minutes, the appliance reverts to standard operating mode.

Standard setting is **00**.

SERVICE FUNCTION 3.A: AUTOMATIC CYCLE BLOCK

With the service function 3.A you can switch on the automatic matching of the cycle block. This may be required for heating systems with less than favourable sizing.

If cycle block matching has been switched off, set it with service function 3.b (→ page 35).

Standard setting is **00** (OFF).

SERVICE FUNCTION 3.B: CYCLE BLOCK

Only if automatic cycle block (service function 3.A) has been switched off will this service function be active.

The cycle block can be set from **00** to **15** (0 to 15 minutes).

Standard setting is **03** (3 minutes).

The cycle block is off at **00**.

The shortest possible switching differential is 1 minute (recommended for single line and convector heaters).

SERVICE FUNCTION 3.C: SWITCHING DIFFERENTIAL

Only if automatic cycle block (service function 3.A) has been switched off will this service function be active.

The switching differential is the permissible differential from the set flow temperature. It can be set in increments of 1 K. The minimum flow temperature is 35 °C.

The switching differential can be set from **00** to **30** (0 to 30 K).

Standard setting is **10** (10 K).

SERVICE FUNCTION 3.E: CYCLE TIME, KEEP HOT DHW

This service function only operates in comfort mode.

It specifies the time from completion of preheating or DHW demand until the next heat-up time for the plate heat exchanger. This prevents the plate heat exchanger overheating.

The cycle time can be set from **20** to **60** minutes.

Standard setting is **20** (20 minutes).

SERVICE FUNCTION 3.F: DURATION OF TEMPERATURE MAINTENANCE

The duration of temperature maintenance specifies how long heating mode remains disabled after DHW is drawn.

The duration of temperature maintenance can be set from **00** to **30** (0 to 30 minutes).

Standard setting is **05** (5 minutes).

SERVICE FUNCTION 4.B: MAXIMUM TEMPERATURE FOR KEEPING THE HEAT EXCHANGER HOT

The maximum temperature for keeping the heat exchanger hot can be set from **40** to **65** (40 °C to 65 °C).

Standard setting is **65** (65 °C).

SERVICE FUNCTION 4.E: APPLIANCE TYPE

This service function displays the determined appliance type.

Possible displays are:

- **00**: Central heating only
- **01**: Combi boiler
- **02**: Cylinder temperature sensor connected to the Control unit
- **03**: Cylinder thermostat connected to Control unit.

SERVICE FUNCTION 4.F: SIPHON FILL PROGRAM

The syphon fill program ensures that the condensate syphon is filled following installation or after the appliance has been out of use for some time.

The syphon fill program is activated if:

- the appliance is switched on at the mains shut-off valve
- the burner has not been in use for at least 28 days
- a change over between summer and winter mode occurs

The next time there is a demand for heat in central heating or DHW mode, the appliance is held at low output for 15 minutes. The syphon filling program remains active until the appliance has completed 15 minutes of operation at low output. The display shows  alternating with the flow temperature.

Standard setting is **01**: Siphon filling program at minimum heating output.

Parameter **02**: Siphon filling program at set minimum heating output.

Parameter **00**: Siphon filling program is off.



DANGER: If the condensate syphon is not filled, flue gas can escape.

- ▶ Switch off syphon filling program only during maintenance.
- ▶ When maintenance is complete, reactivate the syphon filling program.

SERVICE FUNCTION 5.A: RESET INSPECTION

This service function enables you to reset  on the display after completing inspection/maintenance of the appliance.

Setting 00.

SERVICE FUNCTION 5.B: FAN RUN-ON TIME

This service function allows you to set the fan run-on time.

The run-on time can be set from **01** to **18** (10 - 180 seconds).

Standard setting is **03** (30 seconds).

SERVICE FUNCTION 5.C: CHANGING THE USE OF THE CHANNEL ON 1-CHANNEL TIME SWITCHES

This service function enables the use of the channel to be changed from central heating to DHW.

The following settings are possible:

- **00**: 2-channel (central heating and DHW)
- **01**: 1-channel central heating
- **02**: 1-channel DHW

Standard setting is **00**.

SERVICE FUNCTION 5.E: SETTING CONNECTION NP - LP

With this service function you can set the NP - LP connection.

The following settings are possible:

- **00**: Off
- **01**: DHW circulation pump
- **02**: External heating circuit pump in consumer circuit w/o mixer

Standard setting is **00**.

SERVICE FUNCTION 5.F: INSPECTION INDICATION

This service function enables you to set the number of months after which  (inspection) appears alternately with the flow temperature on the display.

The number of months can be set from **00** - **72** (0 to 72 months).

Standard setting is **00** (disabled).



This function has already been selected at the controller if the display shows **U0**.

SERVICE FUNCTION 6.A: CALL UP THE FAULT LAST SAVED

With this service function you can call up the fault last saved.

The service function is reset at **00**.

SERVICE FUNCTION 6.B: ACTUAL VOLTAGE AT TERMINAL 2

The actual voltage at terminal 2 is displayed.

Possible displays are:

- **00** - **24**: 0 V to 24 V in increments of 1 V

SERVICE FUNCTION 6.C: FLOW TEMPERATURE REQUIRED BY HEATING CONTROLLER

This service function allows you to display the flow temperature required by the heating controller.

SERVICE FUNCTION 6.D: CURRENT FLOW RATE

The current flow rate is displayed.

Possible displays are:

- **0.0** - **99.9**: 0.0 to 99 l/min in increments of 0.1 l/min

SERVICE FUNCTION 6.E: TIME SWITCH INPUT

The left digit indicates the current status of the heating system. Heating mode is activated according to the time switch settings.

The right digit indicates the current status of the DHW system. DHW mode is activated according to the time switch settings.

Possible displays are:

- **00**: Central heating disabled, DHW disabled.
- **01**: Central heating disabled, DHW enabled.
- **10**: Central heating enabled, DHW disabled.
- **11**: Central heating enabled, DHW enabled.

SERVICE FUNCTION 7.A: INDICATOR FOR BURNER OPERATION/ FAULTS

When the appliance is switched on, the indicator for burner operation/ faults illuminates constantly for as long as the burner is in operation. You can extinguish the burner operation indicator with service function 7.A; faults will continue to be highlighted by a flashing indicator.

Standard setting is **01** (switched on).

SERVICE FUNCTION 7.B: 3-WAY DIVERTER VALVE IN CENTRE POSITION

After the value **01** has been saved, the 3-way diverter valve moves to its centre position. This ensures the system is fully drained and the motor can be easily removed.

When you exit this service function, the value **00** is automatically saved again.

SERVICE FUNCTION 7.C: MINIMUM DHW VOLUME

This function enables you to set the DHW volume required to switch on the burner to start DHW heating. The setting range is from 2.5 to 5 litres (per minute). The figure displayed (25 to 50) indicates the DHW volume in increments of 0.1 litre (**standard setting**: 2.5 litres; display = 25).

SERVICE FUNCTION 7.E: BUILDING DRYING FUNCTION

This service function can be used to dry out a new build property. Not recommended for use with screeded floors due to high flow temperatures.

This function must not be used for screed drying.

- **00**: Drying function not active
- **01**: Drying function active

Standard setting is **00**.

SERVICE FUNCTION 7.F: CONFIGURATION OF TERMINALS 1-2-4

This service function allows you to set the input voltage across terminals 1-2-4.

The following settings are possible:

- **00**: Input off
- **01**: 0-24 V input, output specification
- **02**: 0-10 V input, output specification
- **03**: 0-10 V input, temperature specification

Standard setting is **01**.

7.3.2 SERVICE LEVEL 2

SERVICE FUNCTION 8.A: SOFTWARE VERSION

The current software version is displayed.

SERVICE FUNCTION 8.B: CODE PLUG NUMBER



The last four digits of the code plug number are shown. The code plug determines the appliance functions.

SERVICE FUNCTION 8.C: GFA STATUS





Internal parameter.

SERVICE FUNCTION 8.D: GFA FAULT

Internal parameter.

SERVICE FUNCTION 8.E: RESTORING APPLIANCE TO STANDARD SETTINGS

This service function enables you to reset the appliance to its standard settings. All service functions that have been changed are reset to their standard settings.

- ▶ Hold down the service key  until it illuminates. The display shows a code such as 1.A
- ▶ Hold down eco key and key lock simultaneously until the displays a service function, e.g. 8.A.
- ▶ Select service function **8.E** with the eco key or key lock.
- ▶ Press and release the Central Heating boost button . The Central Heating boost button  illuminates and the display shows **00**.
- ▶ Hold down the Central Heating boost button  until the display shows . All settings are reset and the appliance restarts with its standard settings.
- ▶ Reset changed service functions to the settings recorded in the commissioning report (→ page 58).

SERVICE FUNCTION 8.F: PERMANENT IGNITION



NOTICE: Ignition transformer may be damaged.

- ▶ Never leave this function on for longer than 2 minutes.

This function enables permanent ignition without gas supply in order to test the ignition.

The following settings are possible:

- **00**: Off
- **01**: On

Standard setting is **00**.

SERVICE FUNCTION 9.A: PERMANENT OPERATING MODE

This function permanently sets one operating mode (**00**, **01** and **02** → Service function 2.F: Operating mode, page 35). Values **03** and **06** have read-only status.

Standard setting is **00**.

SERVICE FUNCTION 9.B: CURRENT FAN SPEED

This service function displays the current fan speed (in revolutions per second).

SERVICE FUNCTION 9.C: CURRENT HEATING OUTPUT / NOX ADJUSTMENT

This service function displays the current appliance heating output (in percent (%)). See section 6.7 for % required for Low NOx (→ page 30).

SERVICE FUNCTION 9.E: FLOW TURBINE SIGNAL DELAY

With this service function a time delay can be set to prevent the appliance starting as a result of brief pressure peaks in the water supply.

Through spontaneous pressure change in the water supply, the flow meter can signal that water is being drawn off. This means the burner starts briefly although no water is drawn off.

The flow meter signal delay can be set from **02** to **12** (0.5 seconds to 3 seconds) in increments of 0.25 seconds.

Standard setting is **04** (1 second).

SERVICE FUNCTION 9.F: PUMP RUN-ON TIME (CH)

With this service function, you can set the pump run-on time after the end of the heat demand from the external controller.

The pump run-on time can be set from **01** to **10** (1 to 10 minutes) in increments of 1 minute.

The **standard setting** is **03** (3 minutes).

SERVICE FUNCTION A.A: TEMPERATURE AT THE FLOW TEMPERATURE SENSOR

This service function allows you to display the temperature at the flow temperature sensor.

SERVICE FUNCTION A.B: DHW TEMPERATURE

This service function allows you to display the DHW temperature.

SERVICE FUNCTION B.F: START DELAY

This service function allows you to set the time in seconds before the appliance starts DHW heating. Set the start delay in accordance with system conditions.

i If a start delay is set, the demand signal is no longer possible → page 32.

The start delay can be set between 0 - 50 seconds.

Standard setting is 00 (disabled).

8 SERVICE

8.1 CHECKING THE GAS SUPPLY PRESSURE

NOTICE:

- ▶ Ensure that the gas pressure is satisfactory with all other gas appliances working.
- ▶ Do not continue with the other checks if the correct gas pressure can not be achieved.

- ▶ Switch off the appliance and turn off the gas tap.
- ▶ Undo the plug on the test port for gas supply pressure and connect a pressure gauge.

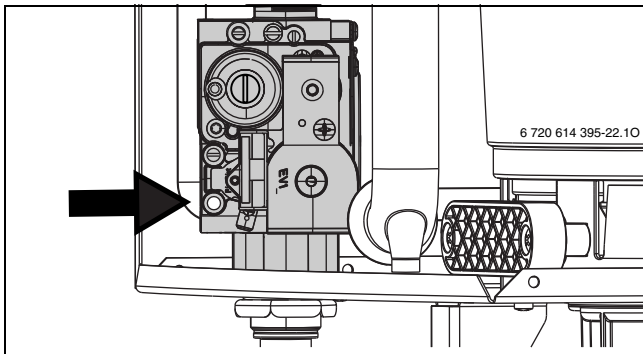

Fig. 59

- ▶ Turn on the gas tap and switch on the appliance.
- ▶ Hold down the Central Heating boost button until it illuminates. The display shows the flow temperature alternating with = **maximum heating output setting**.
- ▶ Press the Central Heating boost button again and the display will show the flow temperature alternating with = **maximum rated output**.
- ▶ Check that the gas working pressures in the system conform to the figures shown below:

Allowed mbar pressure drop				
meter/ regulator	across pipework	boiler inlet	across boiler	gas control valve
Natural gas				
19 - 23	1	18 - 22	1.5	16.5 - 20.5

Table 24

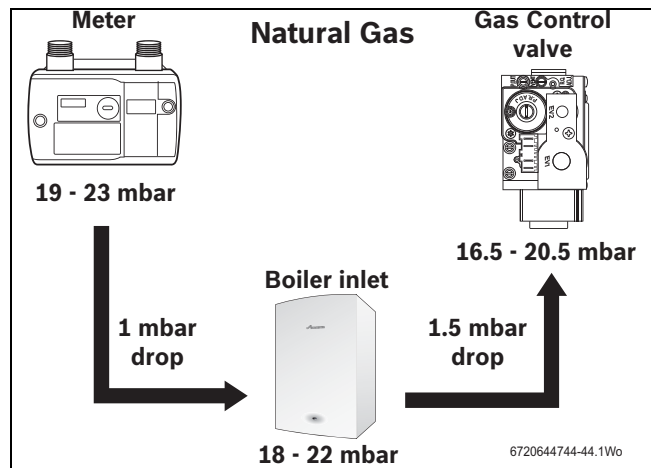

Fig. 60 Natural gas pressure

i The appliance must not be operated if the pressure is above or below these figures. Determine the cause and correct the fault. If that is not possible, securely seal off the gas supply to the appliance and contact the gas supply utility.

- ▶ Repeatedly press the Central Heating boost button until the light extinguishes. The display will show the Central Heating flow temperature.
- ▶ Switch off the appliance, turn the gas tap to OFF, remove the pressure gauge and refit the plug.
- ▶ Refit the outer casing.

8.2 CHECK FLUE INTEGRITY

Central Heating boost button

The following appliance output can be selected by holding down the Central Heating boost button until it illuminates:

- 1st press = = **maximum heating output setting**
- 2nd press = = **maximum rated output**
- 3rd press = = **minimum rated output**
- 4th press = EXIT from Central Heating boost.

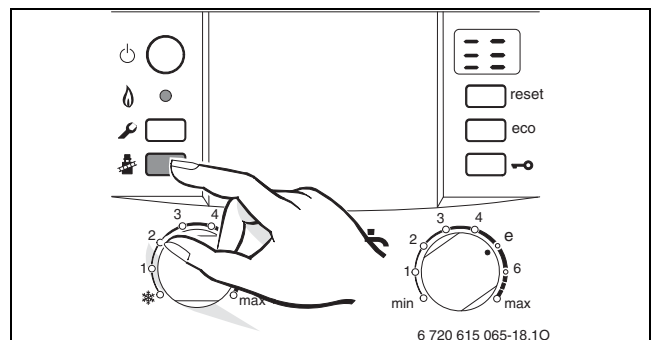

Fig. 61

i You have 15 minutes in which to measure the levels. After that, the appliance reverts from “boost” mode to standard mode.

8.3 CHECKING FLUE SYSTEM FOR TIGHTNESS

Measure the CO₂ levels in combustion air.

Use an annular-gap flue gas probe for this test.



With a type C₁₃, C₃₃ or C₅₃ flue system, the **gas tightness of the flue system** can be tested by measuring the O₂ or CO₂ content of the combustion air. The O₂ level must exceed 20.6%. The CO₂ level must not exceed 0.2%.

- ▶ Remove sealing plug from air inlet sample port [2].
- ▶ Insert a flue gas probe into the test port and seal the test port
- ▶ Press the Central heating boost button until the button illuminates and press once again to select = **maximum rated output**.

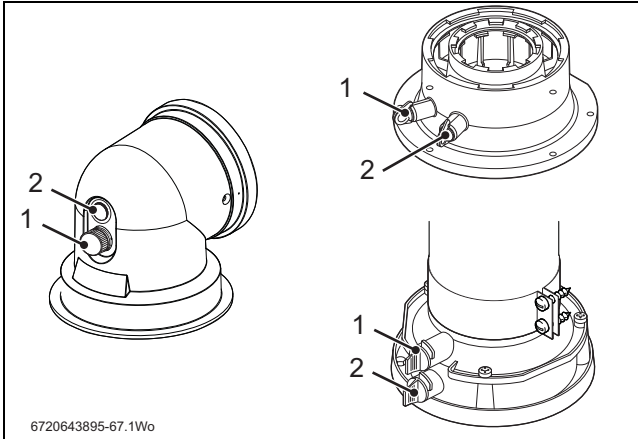

Fig. 62 Flue test ports

- [1] Flue gas sample port
- [2] Air Inlet sample port

- ▶ Allow the readings to stabilise and measure the O₂ and CO₂ levels.
- ▶ Refit sealing plug.

8.4 MEASURING CO CONTENT OF FLUE GAS

Use a multiport flue gas probe for this test.

- ▶ Remove sealing plug from flue gas sample port [1].
- ▶ Insert a flue gas probe as far as it will go into the test port and seal the test port.
- ▶ Press the Central Heating boost button until the button illuminates and press once again to select = **maximum rated output**.
- ▶ Run the boiler at maximum output for at least 10 minutes.



The CO must be less than 200 ppm (0.002 ratio)

- ▶ Measure the CO levels.
- ▶ Repeatedly press the Central Heating boost button until the light extinguishes. The display will show the CH flow temperature.
- ▶ Refit sealing plug.

8.5 SETTING GAS/AIR RATIO (CO₂)



NOTICE: Gas/Air ratio

- ▶ Setting the gas/air ratio must be carried out by a competent person. Testing must not be attempted unless the person carrying out the combustion check is equipped with a Combustion Analyser conforming to BS 7927 and is competent in its use.

- ▶ Switch appliance off at the ON/OFF switch.
- ▶ Remove the outer casing.
- ▶ Switch appliance on at the ON/OFF switch.
- ▶ Remove sealing plug from flue gas test port (1).

- ▶ Insert a flue gas probe approx. 135 mm into the test port socket (1) and seal the port.
- ▶ Hold down the Central Heating boost button until it illuminates. Press the button once again and the display shows the flow temperature alternating with = **maximum rated output**.
- ▶ Measure the CO₂ level.
- ▶ Using a 2.5mm Allen key, adjust the gas flow throttle [3] to set the CO₂ level for maximum rated output according to the table.

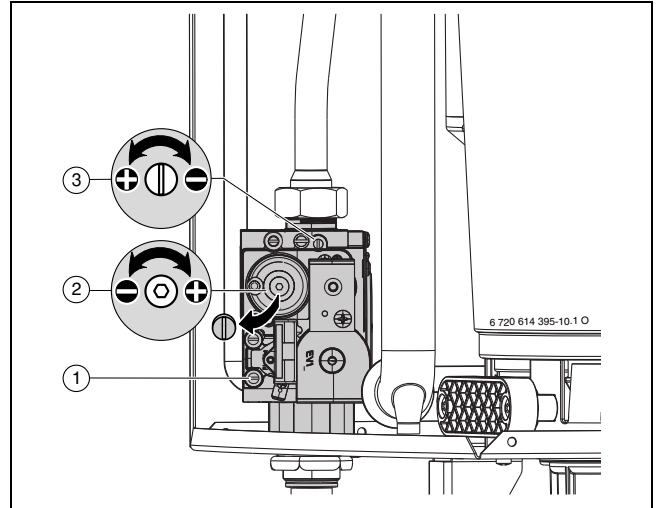

Fig. 63 Gas valve adjustment

- [1] Gas supply pressure test port
- [2] Adjusting screw for min. gas supply flow rate
- [3] Adjusting screw for max. gas supply flow rate

Gas type	CO ₂	CO ₂
	Max. output	Min. output
Natural gas H (23)	9.6 %	8.7 %
Checking tolerance	± 0.5	± 0.5
Adjustment tolerance	± 0.3	± 0.4

When checking an existing appliance the tolerance is ± 0.5%.

If checking after cleaning or component replacement or for adjustment when the reading obtained is outside the tolerance given in table 25, then the tolerance is ± 0.3 for maximum and ± 0.4 for minimum.

CO - less than 200 ppm (0.002 ratio)

Table 25 CO/CO₂ Tolerances

- ▶ Press Central Heating boost button once again. The display shows the flow temperature alternating with = **minimum rated output**.
- ▶ Measure the CO₂ level.
- ▶ Using a flat blade screwdriver, remove the dust cap from gas valve adjusting screw
- ▶ Using a 4 mm Allen key, set CO₂ level for minimum rated output.
- ▶ Replace the dust cap after adjustment.
- ▶ Re-check settings at maximum and minimum rated output and re-adjust if necessary.
- ▶ Record the CO₂ levels in the Benchmark Commissioning checklist.
- ▶ Press the Central Heating boost button again and the light will extinguish. The display will show the CH flow temperature.
- ▶ Remove flue gas probe from flue gas test port (1) and refit sealing plug.

8.6 FAN PRESSURE TEST



This test is to determine if the heat cell requires cleaning or attention



NOTICE: Fan pressure test

▶ The boiler must be run at maximum output for the fan pressure test and flue gas analysis.

- ▶ Check control pressure at maximum rated output at the mixer unit.
- 1. Remove the fan pressure test point cover.
- 2. Connect the digital manometer to the fan pressure test point.

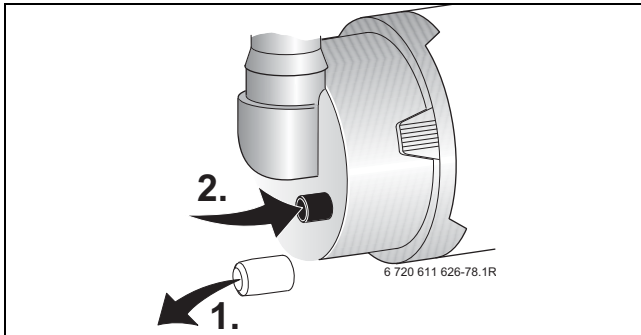

Fig. 64 Fan pressure test point

With the combustion air intake pipe fitted and the boiler running at maximum output, measure the fan pressure:

- ▶ The pressure reading will be negative, refer to fig 65
- ▶ If the manometer reading is in the white area of the chart the heat exchanger/exhaust path/siphon does not require attention.
- ▶ If the manometer reading is in the black area of the chart then carry out the following checks:
 - Check that the siphon is not blocked.
 - Check the exhaust paths for restrictions.
 - Clean the heat exchanger with a suitable cleaning tool, refer to section 10.1.2 - Checking the heat exchanger.

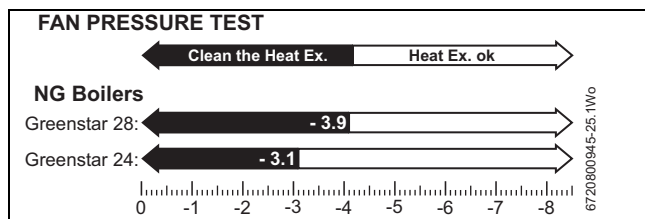

Fig. 65 Fan pressure readings

- ▶ Re-check the fan pressure readings.
- If the boiler, after completing the above checks, fails the fan pressure test then contact Worcester, Bosch Group for advice.
- ▶ After the measurements are taken switch the boiler off.
 - ▶ Remove the combustion air intake pipe.
 - ▶ Disconnect the manometer and replace the test point cover.
 - ▶ Replace the combustion air intake pipe.

9 ENVIRONMENTAL PROTECTION

Environmental protection is a fundamental corporate policy of the Bosch Group.

The quality of our products, their economy and environmental safety are all of equal importance to us and all environmental protection legislation and regulations are strictly observed.

We use the best possible technology and materials to protect the environment taking account of economic considerations.

PACKAGING

We participate in the recycling programmes of the countries where our products are sold to ensure optimum recycling. All of our packaging materials are environmentally compatible and can be recycled.

USED APPLIANCES

Used appliances contain valuable materials that should be recycled. The various assemblies can be easily dismantled and synthetic materials are marked accordingly. Assemblies can therefore be sorted by composition and passed on for recycling or disposal.

10 INSPECTION/MAINTENANCE

To ensure that gas consumption and environmental impact (pollution etc.) remain as low as possible over an extended period of time, we recommend that you take out an inspection/maintenance contract with an authorised contractor covering the annual inspection and servicing and maintenance at other times as required.



DANGER: Risk of explosion

- ▶ Turn off gas tap before working on components in contact with gas.
- ▶ Check for leaks before working on components in contact with gas.



DANGER: Risk of poisoning

- ▶ Check for leaks before working on components in contact with gas.



DANGER: Risk of electric shock

- ▶ Always disconnect the power supply to the appliance at the mains before carrying out any work on the electrical systems and components (fuse, circuit breaker).

CONTROL UNIT

If a component fails, a fault is indicated on the display.

All safety, modulation and control components are monitored by the Control unit.



NOTICE: Leaking water may damage the Control unit.

- ▶ Cover the Control unit before working on any parts that carry water.

IMPORTANT NOTES



An overview of fault codes is given on page 48.

- The following test equipment is required:

- Electronic flue gas emission meter for CO₂, CO and flue gas temperature
- Pressure gauge for 0 - 30 bar (resolution at least 0.1 bar)
- Special tools are not required
- ▶ Use 8 719 918 658 0 as heat conducting paste.
- ▶ Only use genuine spare parts!
- ▶ Refer to the spare parts catalogue when ordering spare parts.
- ▶ Always renew seals and O-rings removed during servicing or repair work.

AFTER INSPECTION/MAINTENANCE

- ▶ Retouching all threaded fittings that have been undone.
- ▶ Readmission the appliance (→ page 28).
- ▶ Check all connections for leaks.
- ▶ Check the gas-air ratio and adjust if necessary (→ page 39).

10.1 DESCRIPTION OF VARIOUS MAINTENANCE OPERATIONS

RETRIEVING LAST FAULT SAVED (SERVICE FUNCTION 6.A)

- ▶ Select service function **6.A** (→ page 36).



An overview of fault codes is given on page 48.

10.1.1 DRAINING THE BOILER

Many of the tasks in this section require that the appliance be isolated from the gas and electrical mains and drained.

CENTRAL HEATING SYSTEM

To drain the boiler:

- ▶ Connect a suitable hose firmly to the drain point and run the hose outside to a suitable point or container.
- ▶ Turn the drain valve a ¼ turn anticlockwise to open the drain valve and drain. Turn the valve firmly clockwise to close.

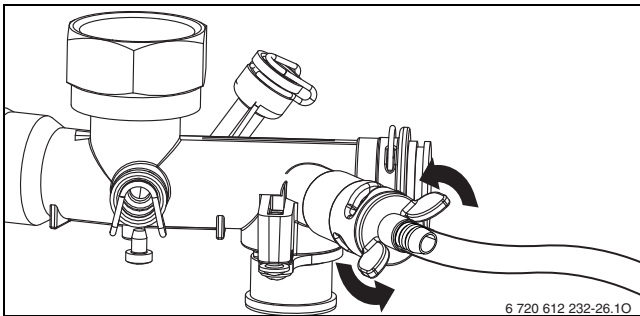

Fig. 66 Draining the appliance

10.1.2 CHECKING HEAT EXCHANGER, BURNER AND ELECTRODES

When cleaning the heat exchanger, use accessory kit consisting of brush and extractor.

If cleaning is required:

1. Remove the air intake pipe.
2. Disconnect gas pipe from mixer unit, → Fig. 67.
3. Remove control pressure hose.
4. Rotate the mixer unit clockwise to the stop.
5. Pull the mixer unit towards you to remove.

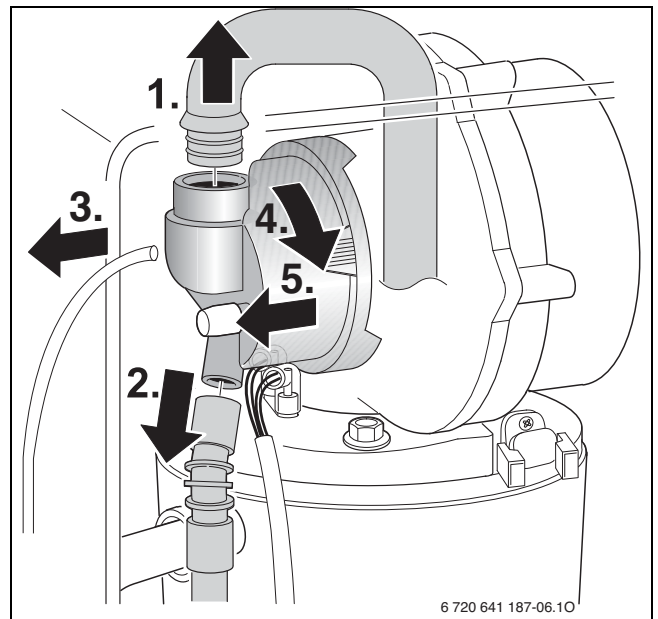

Fig. 67 Removing the mixer unit

1. Disconnect the power cable and earth from the fan and the ignition and flame monitoring electrode leads, → Fig. 68.
2. Unscrew locking nut for fan plate.
3. Lift and tilt the fan to the left and then pull forward to remove the fan.

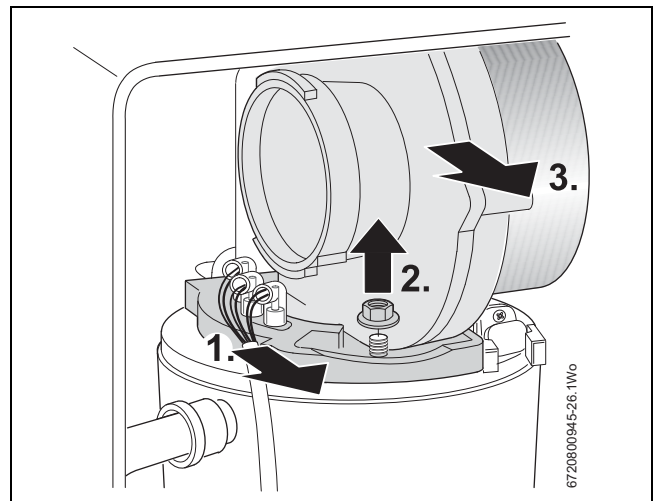

Fig. 68 Fan removal

NOTICE: Burner gasket:

- ▶ Always re-assemble with a new burner gasket, do not re-use the old gasket.

- ▶ Remove electrode assembly, teaselled and gasket, inspect electrodes for corrosion and clean or replace as necessary.
- ▶ Remove burner.

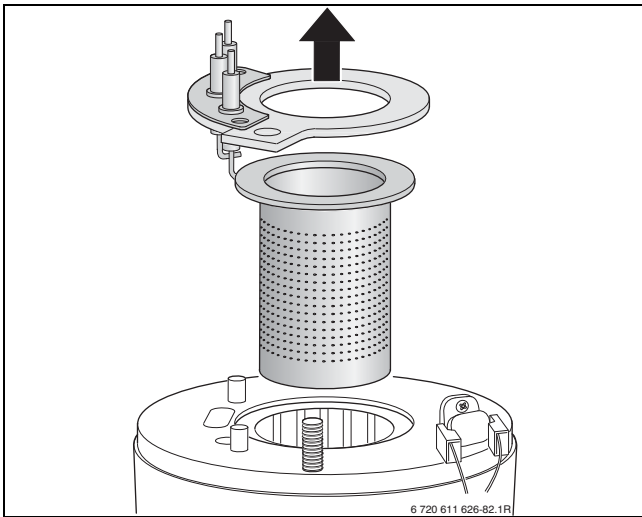

Fig. 69

! **WARNING:** Risk of burning. The heat exchanger baffles can still be very hot even after the appliance has not been used for some time.

- ▶ Cool the heat exchanger baffles with a damp cloth.

- ▶ Remove the top baffle.
- ▶ Remove the bottom baffle using the extractor.
- ▶ Clean both baffles as required.

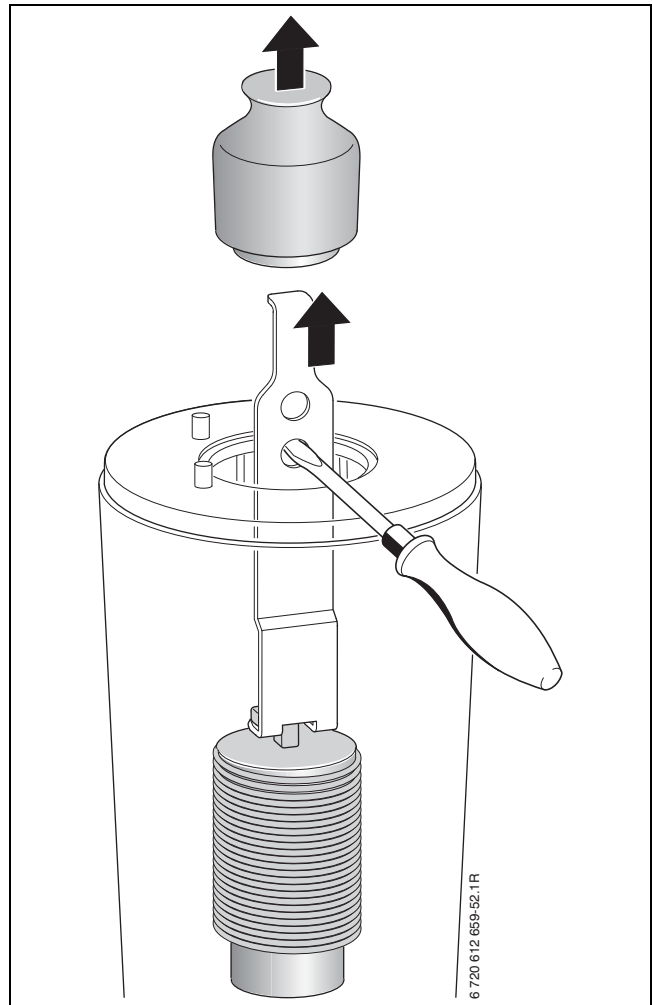

Fig. 70



The heat exchanger can be inspected with the aid of a torch and a mirror.

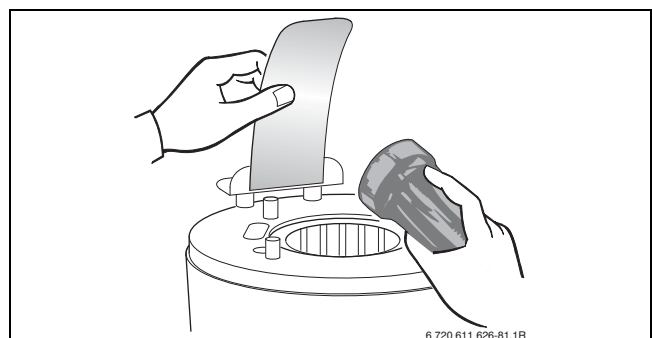

Fig. 71

Clean the heat exchanger with the brush as follows:

1. Move the brush up and down as far as possible
2. Rotate the brush in both directions
3. Undo screws from inspection cover and remove cover.

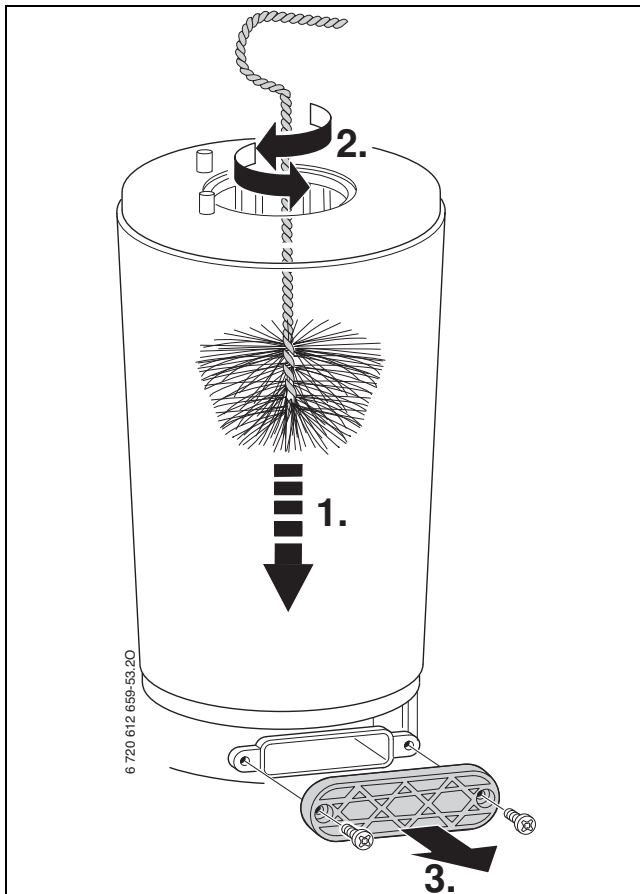

Fig. 72

- ▶ Remove any residue and refit inspection cover.
- ▶ Refit the baffles.
- ▶ Undo the condensation trap and place a suitable container underneath.
- ▶ Flush out the heat exchanger with water from the top.

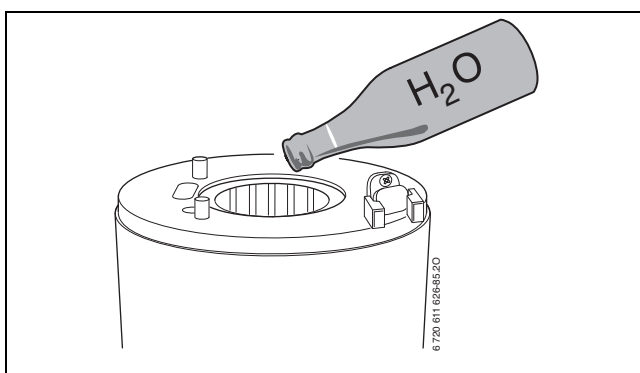

Fig. 73

- ▶ Remove the inspection cover again and clean the condensate pan and connection.
- ▶ Refit the components in reverse order.
- ▶ Reconnect the power cable and earth to the fan.
- ▶ Reconnect the ignition and flame monitoring electrode leads.
- ▶ Check the fan pressure (→ page 40)
- ▶ Adjust the gas-air ratio (→ page 39).

10.1.3 FILTER IN COLD WATER PIPE

- ▶ Undo cold water pipe and check filter for debris.
 1. Release the clip securing the cold water pipe.
 2. Disconnect the cold water pipe.
 3. Remove the gauze filter, check for debris and clean if necessary

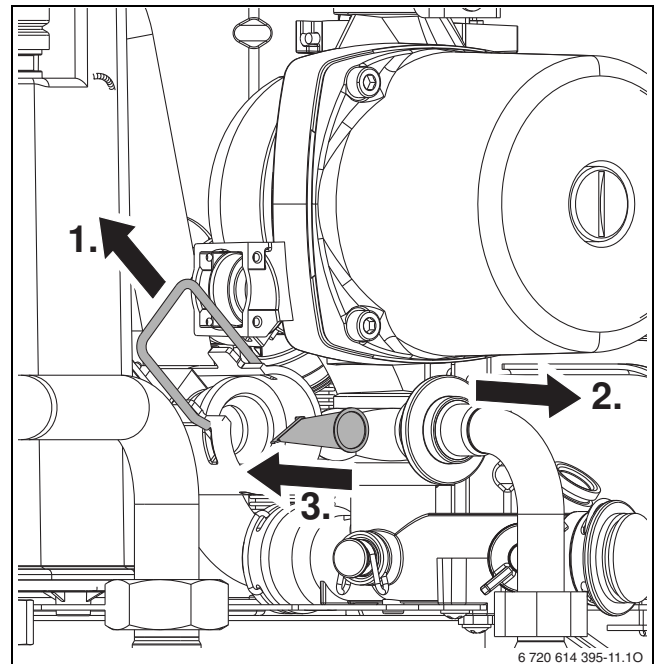

Fig. 74 Cold water filter

10.1.4 PLATE HEAT EXCHANGER

If the DHW output is inadequate:

- ▶ Check filter in cold water pipe for debris (→ Fig. 74).
- ▶ Remove plate heat exchanger and replace

-or-

- ▶ Desolote with a product that has been approved for stainless steel.

To remove plate heat exchanger:

1. Remove screw at the top of the heat exchanger.
 2. Remove the heat exchanger.
- ▶ Fit new heat exchanger with new seals and secure with screw.

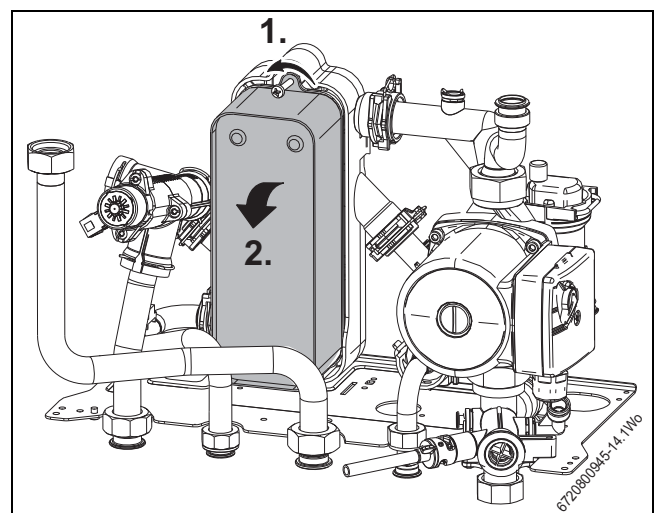

Fig. 75

10.1.5 GAS VALVE

NOTICE: Aluminium washers:
▶ Always re-assemble with a new aluminium washers, do not re-use the old washers.

- ▶ Disconnect electrical connectors.
- ▶ Remove gas connecting pipe.
- ▶ Undo two screws, slide gas valve and retaining plate upwards and off the screws.

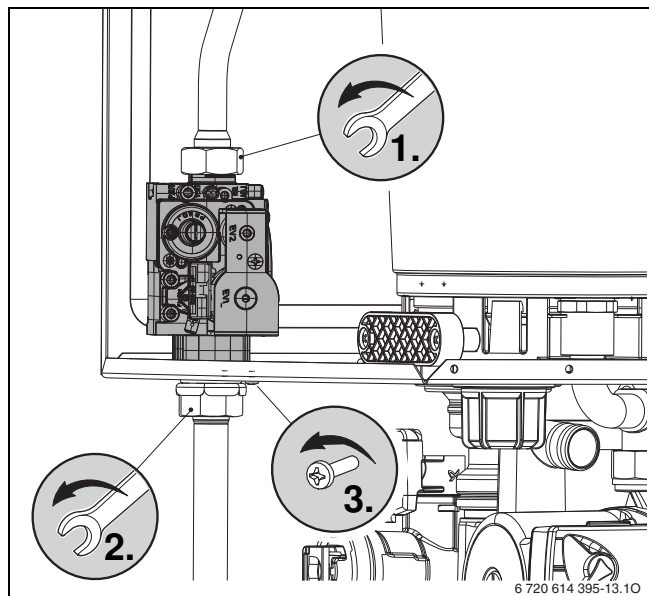

Fig. 76 Gas valve

10.1.6 3-WAY DIVERTER VALVE

- ▶ Undo three clips.
- ▶ Remove pipe [2] completely.
- ▶ Lift 3-way diverter valve upwards to remove.
- ▶ When refitting ensure that the clips go in correctly.

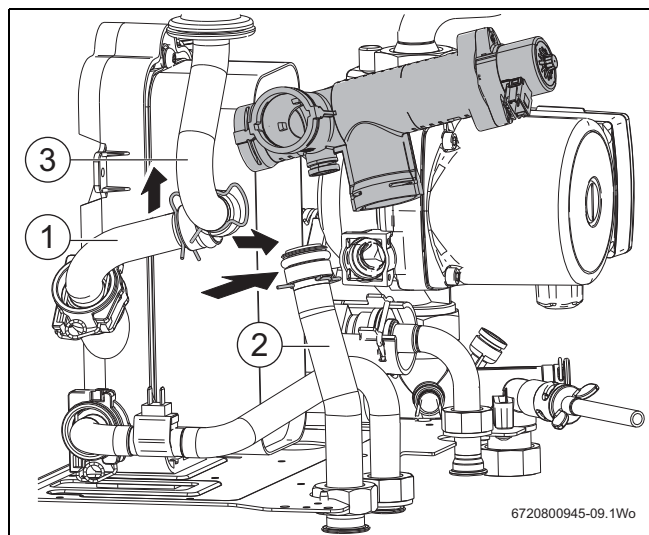

Fig. 77 Diverter valve

[1, 2, 3]Pipes

i For easy assembly of 3-way diverter valve, fit pipe 1 first, then pipe 3 and then refit pipe 2.

10.1.7 REPLACING THE DIVERTER VALVE MOTOR

1. Remove the two screws securing the motor to the diverter valve body.
2. Rock the motor in the direction of the arrow to disengage the motor actuator socket from the ball end of the valve actuator, refer to figure 78 inset below.
3. Remove the motor.

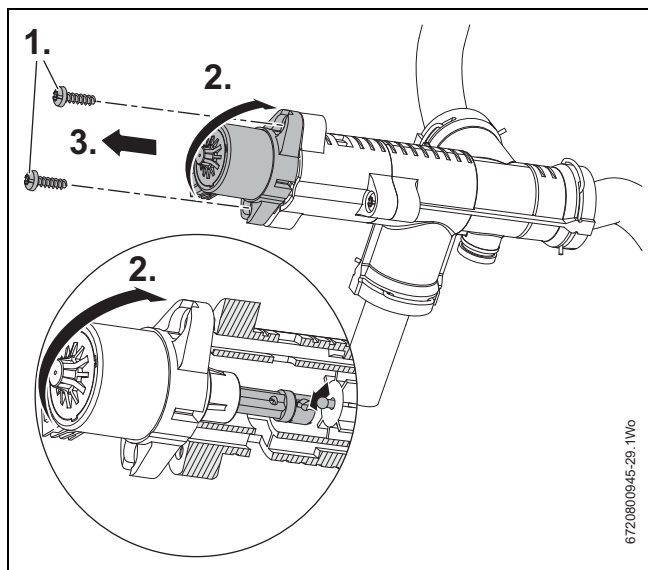

Fig. 78 Disconnect DV motor

When re-assembling the diverter valve motor to the diverter valve body:

- ▶ Ensure that the socket on the motor actuator is aligned as shown in figure 78 inset.
- ▶ Insert the actuator at a slight angle into the valve body and engage the socket onto the ball of the valve actuator.

10.1.8 PUMP AND RETURN MANIFOLD

- ▶ Disconnect PRV speechify connector.
- ▶ Disconnect the mains plug and earth to the pump.
- ▶ Undo pipe union at bottom and top of the pump and lift the pump upwards to remove.
- ▶ Remove clip on rear connection of return manifold.
- ▶ Undo CH return pipe union.
- ▶ Remove the pressure gauge from the fascia.
- ▶ Remove two fixing screws and draw return manifold forwards to remove.

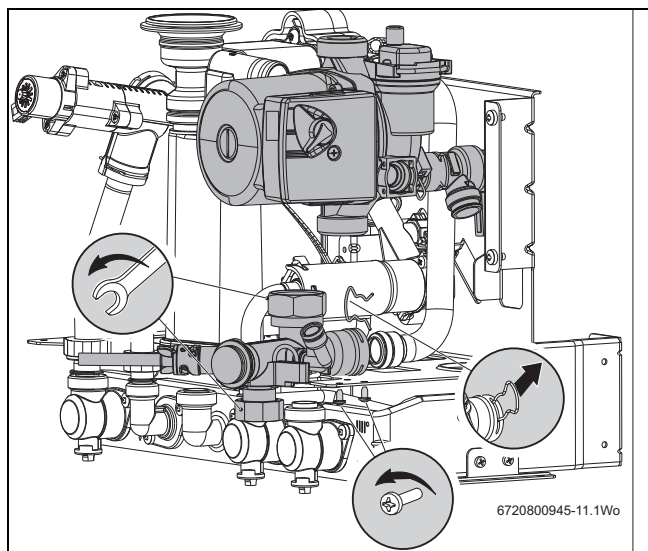

Fig. 79 Pump and manifold return

10.1.9 CLEANING CONDENSATE TRAP

- ▶ Undo screw and remove condensate trap.
- ▶ Check inlet from heat exchanger for clear passage.

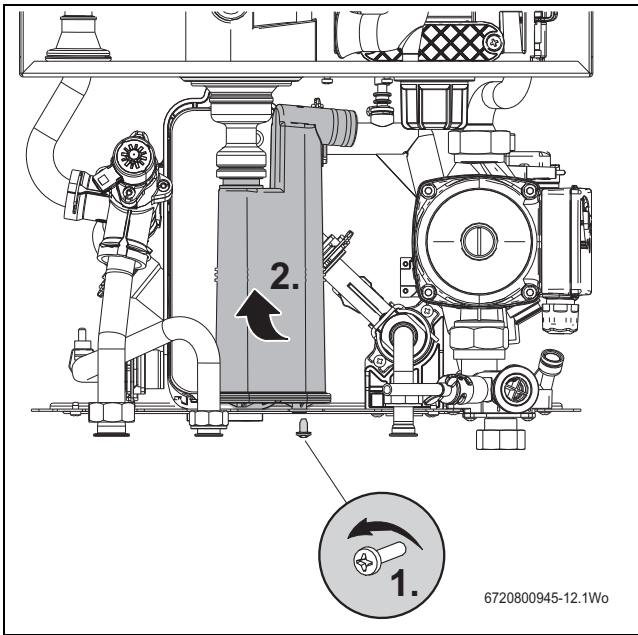

Fig. 80 Condensate trap

- ▶ Flush out condensate trap.
- ▶ Check condensate hose and clean if necessary.
- ▶ Fill condensation trap with approx. 250 millilitres of water and refit.

10.1.10 DIAPHRAGM IN MIXER UNIT

- ▶ Remove diaphragm from mixer unit [1] as shown in Fig. 67.
- ▶ Check the diaphragm [2] for debris and cracks.
- ▶ Refit the mixer unit

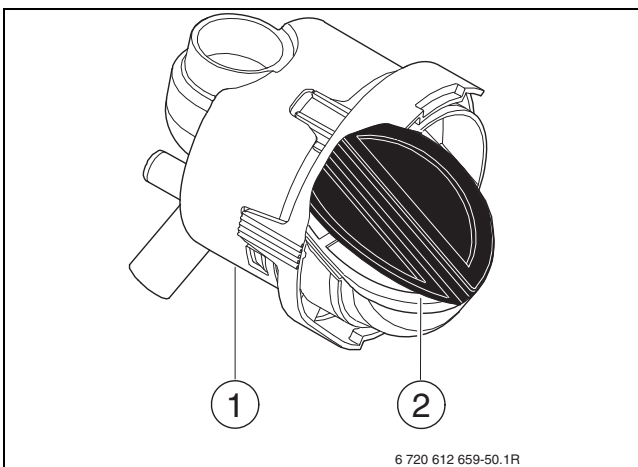

Fig. 81 Mixer unit

10.1.11 CHECKING THE EXPANSION VESSEL

According to DIN 4807, Part 2, Section 3.5, the expansion vessel must be checked annually.

- ▶ Depressurise the boiler.
- ▶ If necessary, adjust the pre-charge pressure of the expansion vessel to the static head of the central heating system.

10.1.12 CHANGING THE EXPANSION VESSEL

If there is 400 millimetres or more space above the boiler and the flue exits to the right or left, the expansion vessel can be removed without removing the boiler from the wall.

Remove the outer case and lower the control panel into the service position to gain access the expansion vessel connection

1. Release the clip at the pump manifold.
2. Pull the connector free from the pump manifold.
3. Lift the expansion vessel up and over the flue.

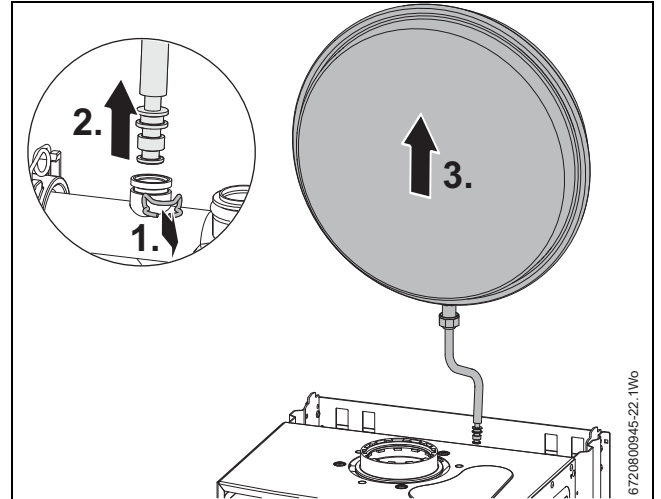

Fig. 82 Boiler still mounted

If there is not 400mm of head room above the boiler, the boiler must be removed from the wall.

1. Release the clip at the pump manifold.
2. Pull the connector free from the pump manifold.
3. Lift the expansion vessel up and out of the boiler.

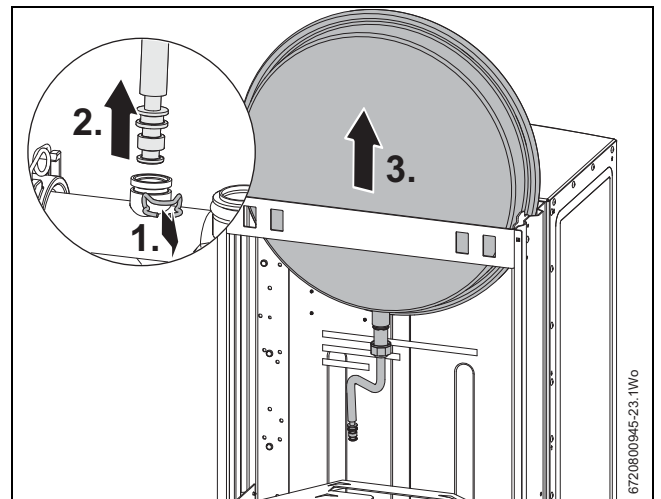

Fig. 83 Boiler dismantled

10.1.13 SETTING THE HEATING SYSTEM PRESSURE

NOTICE: Risk of damage to appliance.

- ▶ Only top up the heating system when the appliance is cold.

Pressure gauge reading	
1 bar	Minimum system pressure (when cold)
1 - 2 bar	Optimum system pressure
3 bar	Maximum system pressure at maximum central heating system temperature: must not be exceeded (safety valve opens).

Table 26

- ▶ If the pointer is below 1 bar (when the system is cold), top up with water to the system until the pointer is between 1 bar and 2 bar again.



Fill the hose with water before topping up the heating system. This will prevent air entering the central heating system.

- ▶ If there is a pressure drop: check the expansion vessel and heating system for leaks.

10.1.14 CHECKING WIRING

- ▶ Check wiring for physical damage and replace faulty leads or cables.

10.1.15 CLEANING OF OTHER COMPONENTS

- ▶ Clean the electrodes, replace if there is any sign of erosion.

10.2 SHORT PARTS LIST



Burner 8 718 120 609 0 	Burner gasket 8 711 004 325 0 
Electrodes set with Gasket 8 737 600 795 0 	Expansion Vessel 8 716 142 502 0 
Temperature limiter assembly 8 710 506 267 0 	Temperature sensor 8 714 500 087 0 
Fan 8 717 204 410 0 	Pressure gauge 8 718 224 344 0 

Table 27





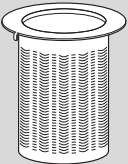
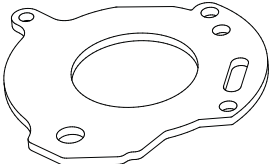
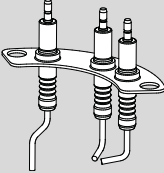
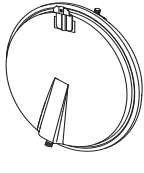
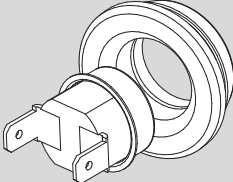
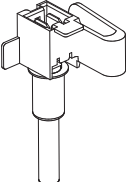
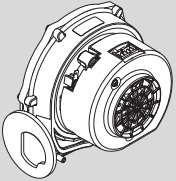

High limit stat 8 707 206 196 0 	PRV 8 716 010 793 0 
Gas Valve 8 716 012 485 0 	Pump 8 716 010 880 0 
Heat Exchanger 8 716 771 987 0 	Diverter valve motor 8 718 642 957 0 
DHW Temperature sensor 8 716 010 809 0 	Flow limiter 8 716 141 054 0 – 8 Litres 8 716 141 057 0 – 10 Litres 8 716 141 061 0 – 12 Litres 
Flow turbine 8 717 002 132 0 	Pressure gauge assy 8 716 011 067 0 
Controller circuit board 8 737 702 958 	Fuse 1.6A 1 904 522 740 0 
Fuse 0.5A 1 904 522 730 0 	Fuse 2.5A (Pack of 10) 1 904 521 342 0 
Auto Air Vent 8 718 505 039 0 	Terminal end 8 718 681 828 0 

Table 27

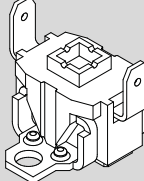
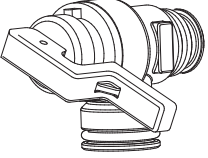
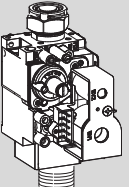
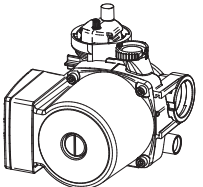
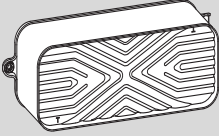
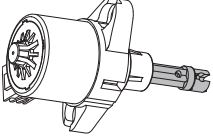
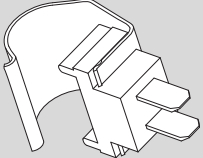
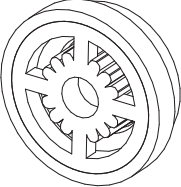
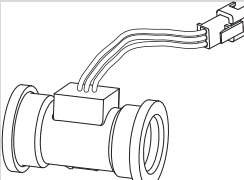
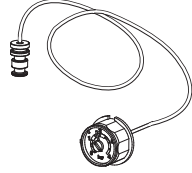
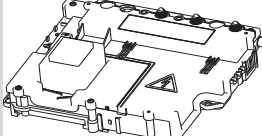

Flue sample plug - vertical adapter 8 710 506 199 0		Flue sample plug - air intake 8 716 111 253 0	
Flue sample plug - gas outlet 8 716 111 252 0		Air pressure switch 8 716 106 633 0	
Air pressure switch bracket 8 718 641 789 0		Hose 8 716 010 113 0	

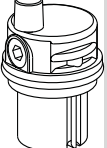
Table 27

11 DISPLAYS

The display shows the following (table 28 and 29):

Display	Description	Range
Figure or letter, dot followed by letter	Service function (→ table 21/ 22, page 34)	
Letter followed by figure or letter	Fault code flashes (→ table 30, page 48)	
Two figures	Decimal value e.g. flow temperature	00..99
U followed by 0..9	Decimal value; 100..109 is displayed as U0..U9	0..109
One figure followed by two times two figures	Decimal value (three digits); first digit is shown alternating with the two last digits (e.g. 1..69 means 169)	0..999
Two dashes followed by two pairs of figures	Code plug number; Value is shown in three stages: 1. Two dashes 2. First two figures 3. Last two figures (e.g.: -- 10 04)	9999
Two letters followed by two pairs of figures	Version number; Value is shown in three stages: 1. First two letters 2. First two figures 3. Last two figures (e.g.: CF 10 20)	

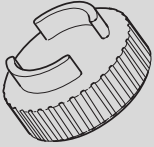
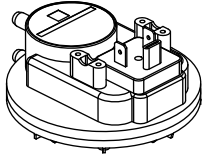
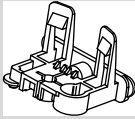
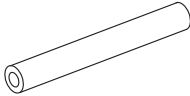
Table 28 Displays





Special display	Description
	Acknowledge by pressing any key (except reset).
	Acknowledge by pressing two keys simultaneously.
	Acknowledge by holding down  for more than 3 seconds (save function).

Table 29 Special displays









Special display	Description
	The display shows the flow temperature alternating with  . The appliance operates for 15 minutes at the minimum rated output.
	The display shows the flow temperature alternating with  . The appliance operates with the set maximum rated output in central heating mode, → service function 1.A .
	The display shows the flow temperature alternating with  . The appliance operates for 15 minutes at the maximum rated output.
	Vent function active, see service function 2.C .
	The display shows the flow temperature alternating with  . The syphon fill program is active, → service function 4.F .

Table 29 Special displays









Special display	Description
	The display shows the flow temperature alternating with  : the set inspection interval has elapsed, → service function 5.A .
	The display shows the flow temperature alternating with  . The heating circuit pump is blocked.
	The display shows the flow temperature alternating with  . The temperature gradient limiter is enabled. Excessive flow temperature increase: central heating mode is suspended for two minutes.
	Screed drying function of the weather-compensated controller (→ operating instructions) or building drying function (→ service function 7.E) operational.
	Key lock enabled. To reset the key lock, press  until the flow temperature is shown on the display.

Table 29 Special displays

12.2 FAULTS THAT ARE DISPLAYED

Display	Remedy
A7 DHW temperature sensor faulty.	Check the temperature sensor and connecting lead for breaks or short circuits.
A8 Communication fault.	Check BUS device connecting lead.
Ad Cylinder temperature sensor not detected.	Check cylinder temperature sensor and connecting lead.
b1 Code plug not detected.	Insert code plug correctly, test and replace if necessary.
b2 Internal data error.	See servicing instructions for heating contractors.
b3	
C6 Fan not running.	Check fan lead and connector, check fan, replace as necessary.
CC Outside temperature sensor not detected.	Check outside temperature sensor and connecting lead for breaks.
d3 External limiter has tripped.	Temperature limiter TB1 has tripped. Jumper across 8-9 or PR-P0 is missing.
d5 External primary NTC on low loss header defect.	Check NTC and cable continuity.
E2 Temperature sensor in CH flow faulty.	Check the temperature sensor and connecting lead.
E9 Heat exchanger temperature limiter or flue gas temperature limiter has tripped. or Flue pipe is blocked.	Check system pressure, temperature limiter, pump operation, fuse on PCB bleed appliance. Check water-side of heat exchanger. On appliances with displacement bodies in heat exchanger, check whether displacement bodies are fitted. Check the flue (fresh air or exhaust gas) pipe blockage, check air pressure switch and air pressure switch pipe. Check heat exchanger high limit stat and flue high limit stat.
EA Flame not detected.	Is gas tap open? Check gas supply pressure, mains power connection, electrodes and leads, flue pipe, gas-air ratio. On natural gas appliances, check external gas flow switch.
F0 Internal fault.	Check electrical connectors and ignition leads, replace PCB if necessary. Check gas-air ratio.
F1 Internal data error.	See servicing instructions for heating contractors.
F7 A flame is detected although the appliance is switched off.	Check electrodes. Flue system OK? Check PCB for moisture.
FA A flame is detected after the gas has been switched off.	Check gas valve. Clean condensate trap and check electrodes. Flue system OK?
Fd Reset was pressed in error.	Press reset again.

Table 30 Displayed faults

12.3 FAULTS THAT ARE NOT DISPLAYED

Appliance faults	Remedy
Excessive combustion noise; rumbling noises	<ul style="list-style-type: none"> ▶ Insert coding plug correctly. Replace if required. ▶ Check gas type. ▶ Check gas supply pressure. Adjust if required. ▶ Check flue system. Clean or repair if required. ▶ Check gas-air ratio in the combustion air and flue gas. Replace gas valve if required.
Flow noises	<ul style="list-style-type: none"> ▶ Set pump stages or pump parameters correctly and match to maximum output.
Heat-up takes too long	<ul style="list-style-type: none"> ▶ Set pump stages or pump parameters correctly and match to maximum output.
Flue gas readings incorrect; CO levels too high	<ul style="list-style-type: none"> ▶ Check gas type. ▶ Check gas supply pressure. Adjust if required. ▶ Check flue system. Clean or repair if required. ▶ Check gas-air ratio in flue gas. Replace gas valve if required.
Ignition too strong, too weak	<ul style="list-style-type: none"> ▶ Check gas type. ▶ Check gas supply pressure. Adjust if required. ▶ Check power supply. ▶ Check electrodes and leads. Replace if required. ▶ Check flue system. Clean or repair if required. ▶ Check gas-air ratio. Replace gas valve if required. ▶ For natural gas: Check external gas flow limiter. Replace if required. ▶ Check burner. Replace if required.
Set flow temperature exceeded	<ul style="list-style-type: none"> ▶ Switch OFF automatic cycle block, i.e. set the value to 0. ▶ Set the required cycle block, e.g. standard setting of 3 minutes.
Condensate in air box	<ul style="list-style-type: none"> ▶ Insert diaphragm in the mixing facility as per installation instructions. Replace if required.
DHW temperature is not reached	<ul style="list-style-type: none"> ▶ Insert coding plug correctly. Replace if required. ▶ Check whether voltage (230 V AC) is present across terminal 1 and terminal 3. Repair if required. ▶ Check flow meter. Replace if required.
Control unit is flashing (i.e. all keys, all display segments, burner indicator etc. are flashing)	<ul style="list-style-type: none"> ▶ Replace fuse Si 3 (24 V).

Table 31 Faults not displayed

12.4 SENSOR VALUES

12.4.1 FLOW TEMPERATURE SENSOR

Temperature/ °C (tol.± 10%)	Resistance (Ω)
20	14 772
25	11 981
30	9 786
35	8 047
40	6 653
45	5 523
50	4 608
55	3 856
60	3 243
65	2 744
70	2 332
75	1 990
80	1 704
85	1 464
90	1 262
95	1 093
100	950

Table 32

12.4.2 DHW TEMPERATURE SENSOR

Temperature/ °C (tol.± 10%)	Resistance (Ω)
0	33242
10	19947
20	12394
30	7947
40	5242
50	3548
60	2459
70	1740
80	1256
90	923

Table 33

12.5 CODE PLUG

Appliance	Number
24-3 C 23	8 714 431 154 0
28-3 C 23	8 714 431 156 0
30-3 C 23	8 714 431 172 0

Table 34

NOTES

NOTES

NOTES

NOTES

GAS BOILER SYSTEM COMMISSIONING CHECKLIST

This Commissioning Checklist is to be completed in full by the competent person who commissioned the boiler as a means of demonstrating compliance with the appropriate Building Regulations and then handed to the customer to keep for future reference.

Failure to install and commission according to the manufacturer's instructions and complete this Benchmark Commissioning Checklist will invalidate the warranty. This does not affect the customer's statutory rights.

Customer name:				Telephone number:				
Address:								
Boiler make and model:								
Boiler serial number:								
Commissioned by (PRINT NAME):				Gas Safe register number:				
Company name:				Telephone number:				
Company address:								
				Commissioning date:				
To be completed by the customer on receipt of a Building Regulations Compliance Certificate*								
Building Regulations Notification Number (if applicable):								
CONTROLS (tick the appropriate boxes)								
Time and temperature control to heating	Room thermostat and programmer/timer	<input type="checkbox"/>	Programmable room thermostat	<input type="checkbox"/>				
	Load/weather compensation	<input type="checkbox"/>	Optimum start control	<input type="checkbox"/>				
Time and temperature control to hot water	Cylinder thermostat and programmer/timer	<input type="checkbox"/>	Combination Boiler	<input type="checkbox"/>				
Heating zone valves	Fitted	<input type="checkbox"/>	Not required	<input type="checkbox"/>				
Hot water zone valves	Fitted	<input type="checkbox"/>	Not required	<input type="checkbox"/>				
Thermostatic radiator valves	Fitted	<input type="checkbox"/>	Not required	<input type="checkbox"/>				
Automatic bypass to system	Fitted	<input type="checkbox"/>	Not required	<input type="checkbox"/>				
Boiler interlock			Provided	<input type="checkbox"/>				
ALL SYSTEMS								
The system has been flushed and cleaned in accordance with BS7593 and boiler manufacturer's instructions							Yes	<input type="checkbox"/>
What system cleaner was used?								
What inhibitor was used?							Quantity	litres
Has a primary water system filter been installed?							Yes	No
CENTRAL HEATING MODE measure and record:								
Gas rate	m ³ /hr	<input type="text"/>	OR	ft ³ /hr	<input type="text"/>			
Burner operating pressure (if applicable)	mbar	<input type="text"/>	OR Gas inlet pressure	mbar	<input type="text"/>			
Central heating flow temperature					°C	<input type="text"/>		
Central heating return temperature					°C	<input type="text"/>		
COMBINATION BOILERS ONLY								
Is the installation in a hard water area (above 200ppm)?							Yes	No
If yes, and if required by the manufacturer, has a water scale reducer been fitted?							Yes	No
What type of scale reducer has been fitted?								
DOMESTIC HOT WATER MODE Measure and Record:								
Gas rate	m ³ /hr	<input type="text"/>	OR	ft ³ /hr	<input type="text"/>			
Burner operating pressure (at maximum rate)	mbar	<input type="text"/>	OR Gas inlet pressure at maximum rate	mbar	<input type="text"/>			
Cold water inlet temperature					°C	<input type="text"/>		
Hot water has been checked at all outlets							Yes	Temperature
Water flow rate					l/min	<input type="text"/>		
CONDENSING BOILERS ONLY								
The condensate drain has been installed in accordance with the manufacturer's instructions and/or BS5546/BS6798							Yes	<input type="checkbox"/>
ALL INSTALLATIONS								
Record the following:	At max. rate:	CO	ppm	AND	CO/CO ₂	Ratio	<input type="text"/>	
	At min. rate: (where possible)	CO	ppm	AND	CO/CO ₂	Ratio	<input type="text"/>	
The heating and hot water system complies with the appropriate Building Regulations							Yes	<input type="checkbox"/>
The boiler and associated products have been installed and commissioned in accordance with the manufacturer's instructions							Yes	<input type="checkbox"/>
The operation of the boiler and system controls have been demonstrated to and understood by the customer							Yes	<input type="checkbox"/>
The manufacturer's literature, including Benchmark Checklist and Service Record, has been explained and left with the customer							Yes	<input type="checkbox"/>
Commissioning Engineer's Signature								
Customer's Signature								
(To confirm satisfactory demonstration and receipt of manufacturer's literature)								

*All installations in England and Wales must be notified to Local Authority Building Control (LABC) either directly or through a Competent Persons Scheme. A Building Regulations Compliance Certificate will then be issued to the customer.



SERVICE RECORD

It is recommended that your heating system is serviced regularly and that the appropriate Service Interval Record is completed.

Service Provider

Before completing the appropriate Service Record below, please ensure you have carried out the service as described in the manufacturer's instructions. Always use the manufacturer's specified spare part when replacing controls.

SERVICE 01					Date:
Engineer name:					
Company name:					
Telephone No:					
Gas safe register No:					
Record:	At max. rate:	CO	ppm	AND	CO ₂ %
	At min. rate: (Where Possible)	CO	ppm	AND	CO ₂ %
Comments:					
Signature					

SERVICE 02					Date:
Engineer name:					
Company name:					
Telephone No:					
Gas safe register No:					
Record:	At max. rate:	CO	ppm	AND	CO ₂ %
	At min. rate: (Where Possible)	CO	ppm	AND	CO ₂ %
Comments:					
Signature					

SERVICE 03					Date:
Engineer name:					
Company name:					
Telephone No:					
Gas safe register No:					
Record:	At max. rate:	CO	ppm	AND	CO ₂ %
	At min. rate: (Where Possible)	CO	ppm	AND	CO ₂ %
Comments:					
Signature					

SERVICE 04					Date:
Engineer name:					
Company name:					
Telephone No:					
Gas safe register No:					
Record:	At max. rate:	CO	ppm	AND	CO ₂ %
	At min. rate: (Where Possible)	CO	ppm	AND	CO ₂ %
Comments:					
Signature					

SERVICE 05					Date:
Engineer name:					
Company name:					
Telephone No:					
Gas safe register No:					
Record:	At max. rate:	CO	ppm	AND	CO ₂ %
	At min. rate: (Where Possible)	CO	ppm	AND	CO ₂ %
Comments:					
Signature					

SERVICE 06					Date:
Engineer name:					
Company name:					
Telephone No:					
Gas safe register No:					
Record:	At max. rate:	CO	ppm	AND	CO ₂ %
	At min. rate: (Where Possible)	CO	ppm	AND	CO ₂ %
Comments:					
Signature					

SERVICE 07					Date:
Engineer name:					
Company name:					
Telephone No:					
Gas safe register No:					
Record:	At max. rate:	CO	ppm	AND	CO ₂ %
	At min. rate: (Where Possible)	CO	ppm	AND	CO ₂ %
Comments:					
Signature					

SERVICE 08					Date:
Engineer name:					
Company name:					
Telephone No:					
Gas safe register No:					
Record:	At max. rate:	CO	ppm	AND	CO ₂ %
	At min. rate: (Where Possible)	CO	ppm	AND	CO ₂ %
Comments:					
Signature					

SERVICE 09					Date:
Engineer name:					
Company name:					
Telephone No:					
Gas safe register No:					
Record:	At max. rate:	CO	ppm	AND	CO ₂ %
	At min. rate: (Where Possible)	CO	ppm	AND	CO ₂ %
Comments:					
Signature					

SERVICE 10					Date:
Engineer name:					
Company name:					
Telephone No:					
Gas safe register No:					
Record:	At max. rate:	CO	ppm	AND	CO ₂ %
	At min. rate: (Where Possible)	CO	ppm	AND	CO ₂ %
Comments:					
Signature					

*All installations in England and Wales must be notified to Local Authority Building Control (LABC) either directly or through a Competent Persons Scheme. A Building Regulations Compliance Certificate will then be issued to the customer.



Worcester, Bosch Group
Cotswold Way, Warndon, Worcester WR4 9SW.
Tel. 0330 123 9559

Worcester, Bosch Group is a brand name of Bosch Thermotechnology Ltd.
worcester-bosch.co.uk

6 720 811 922 (2014/07)

WORCESTER, BOSCH GROUP:

TECHNICAL SUPPORT:	0330 123 3366
APPOINTMENTS:	0330 123 9339
SPARES:	0330 123 9779
LITERATURE:	0330 123 9119
TRAINING:	0330 123 0166
SALES:	0330 123 9669



WORCESTER
Bosch Group