

INSTRUCTION MANUAL

INSTALLATION, COMMISSIONING & SERVICING

WALL HUNG RSF GAS FIRED CONDENSING BOILER

GREENSTAR 12Ri, 15Ri, 18Ri & 24Ri

FOR OPEN VENTED AND SEALED CENTRAL HEATING SYSTEMS AND
INDIRECT MAINS FED DOMESTIC HOT WATER

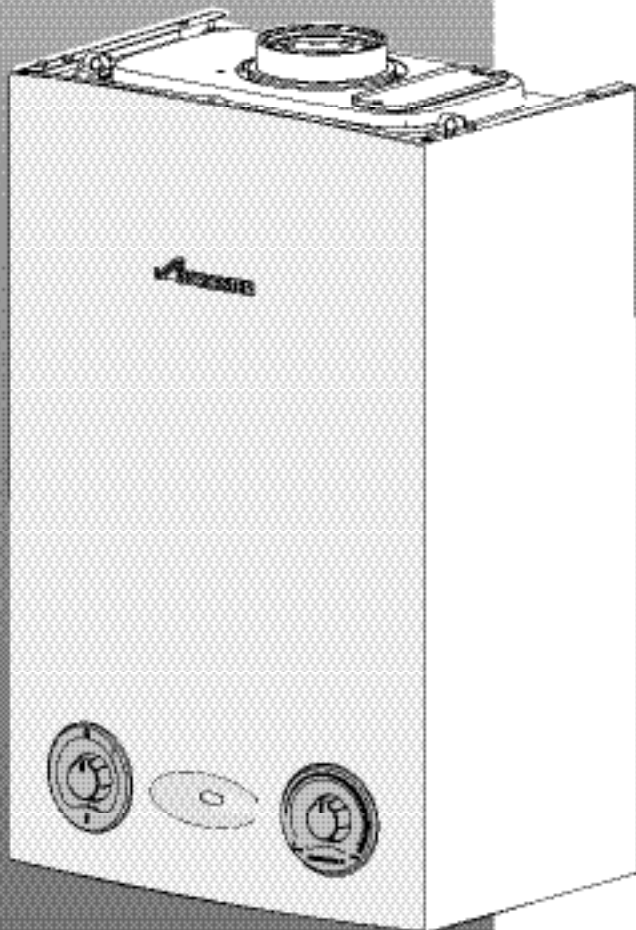

THIS BOILER IS USED WITH
NATURAL GAS OR LPG (Cat II 2H3P TYPE C13, C33 & C53)

NATURAL GAS	12 Ri	GC NUMBER: 41 311 63
	15 Ri	GC NUMBER: 41 311 75
	18 Ri	GC NUMBER: 41 311 77
	24 Ri	GC NUMBER: 41 311 65

LIQUID PETROLEUM GAS	12 Ri	GC NUMBER: 41 311 64
	15 Ri	GC NUMBER: 41 311 76
	18 Ri	GC NUMBER: 41 311 78
	24 Ri	GC NUMBER: 41 311 66



INSTALLATION & SERVICING INSTRUCTIONS

SYMBOLS USED IN THIS MANUAL:



Domestic hot water



Central heating



Hot water storage cylinder



Cold water main supply



Electricity supply



Gas supply

LIFTING AND CARRYING PRECAUTIONS:

- Lift only a manageable weight, or ask for help.
- When lifting the boiler, bend the knees, and keep the back straight and feet apart.
- Do not lift and twist at the same time.
- Lift and carry the boiler close to the body
- Wear protective clothing and gloves to protect from any sharp edges

WATER TREATMENT:

FERNOX 01799 550811

www.fernox.com

SENTINEL 0800 389 4670

www.sentinel-solutions.net

FLUE TERMINAL GUARDS:

TOWER FLUE COMPONENTS LTD.

Vale Rise, Tonbridge TN9 1TB

01732 351555

PLEASE READ THESE INSTRUCTIONS CAREFULLY BEFORE STARTING INSTALLATION.

THESE INSTRUCTIONS ARE APPLICABLE TO THE WORCESTER APPLIANCE MODEL(S) STATED ON THE FRONT COVER OF THIS MANUAL ONLY AND MUST NOT BE USED WITH ANY OTHER MAKE OR MODEL OF APPLIANCE.

THE INSTRUCTIONS APPLY IN THE UK/IE ONLY AND MUST BE FOLLOWED EXCEPT FOR ANY STATUTORY OBLIGATION.

THIS APPLIANCE MUST BE INSTALLED BY A CORGI REGISTERED, COMPETENT PERSON. FAILURE TO INSTALL CORRECTLY COULD LEAD TO PROSECUTION.

IF YOU ARE IN **ANY DOUBT** CONTACT THE WORCESTER TECHNICAL HELPLINE.

DISTANCE LEARNING AND TRAINING COURSES ARE AVAILABLE FROM WORCESTER.

PLEASE LEAVE THESE INSTRUCTIONS WITH THE COMPLETED BENCHMARK CHECKLIST, (OR A CERTIFICATE CONFIRMING COMPLIANCE WITH IS 813, EIRE ONLY) AND THE USER MANUAL WITH THE OWNER OR AT THE GAS METER AFTER INSTALLATION OR SERVICING. THE BENCHMARK CHECKLIST CAN BE FOUND IN THE BACK TWO PAGES OF THE INSTALLATION MANUAL.

ABBREVIATIONS USED IN THIS MANUAL:

∅	Diameter
NG	Natural Gas
LPG	Liquid Petroleum Gas
CH	Central Heating
DHW	Domestic Hot Water
IP	Ingress Protection
SEDBUK	Seasonal Efficiency of Domestic Boilers in the United Kingdom

SAFETY & REGULATIONS

SAFETY PRECAUTIONS & SYMBOLS	2
INSTALLATION REGULATIONS	2

APPLIANCE INFORMATION

GENERAL INFORMATION	3
TECHNICAL DATA	4
LAYOUT & COMPONENTS	5

PRE-INSTALLATION

CLEANING PRIMARY SYSTEMS	6
MAINS SUPPLY	7
WATER SYSTEMS & PIPEWORK	8
CONDENSATE PIPEWORK	9
BOILER LOCATION & CLEARANCES	10
PLUMBING MANIFOLD	12
FLUE OPTIONS	13
FLUE TERMINAL POSITIONS	14

INSTALLATION

UNPACKING THE APPLIANCE	16
WALL MOUNTING PLATE / FLUE OPENING	17
OUTER CASE REMOVAL	18
BOILER CONNECTIONS (GAS/WATER)	19
FLUE INSTALLATION	20
CONDENSATE CONNECTIONS	23
ELECTRICS	24
POSITION OF WIRED COMPONENTS	25

COMMISSIONING

PRE-COMMISSIONING CHECKS	26
FILLING THE SYSTEM	27
STARTING THE APPLIANCE	28
WATER TREATMENT	29
COMMISSIONING	30
FINISHING COMMISSIONING	31

SERVICING & SPARES

INSPECTION AND SERVICE	32
SETTING THE AIR/GAS RATIO	38
REPLACEMENT OF PARTS	41
SHORT PARTS LIST	46

CONVERSION KITS

GAS. CONVERSION	47
-----------------	----

FAULT FINDING & DIAGNOSIS

ELECTRICAL WIRING DIAGRAM	48
FAULT FINDING	49
MAIN FUNCTION	50
BENCHMARK CHECKLIST & SERVICE RECORD SHEET PRINTED AT THE REAR OF THE MANUAL	

SAFETY PRECAUTIONS

IF YOU SMELL GAS:

- X **DON'T** SMOKE OR STRIKE MATCHES
- X **DON'T** TURN ELECTRICAL SWITCHES ON OR OFF
- ✓ **DO** PUT OUT NAKED FLAMES
- ✓ **DO** OPEN DOORS AND WINDOWS
- ✓ **DO** KEEP PEOPLE AWAY FROM THE AREA AFFECTED
- ✓ **DO** TURN OFF THE CONTROL VALVE AT THE METER
- ✓ **DO** CALL YOUR GAS COMPANY



A Benchmark Checklist is provided by Worcester, Bosch Group, at the back of this manual, for the installer to complete. The checklist will include their CORGI registration number to confirm that the boiler has been installed, commissioned and serviced according to the manufacturer's instructions.

IMPORTANT: The completed Benchmark Checklist will be required in the event of any warranty work and may be required by the local Building Control Inspector.

HEALTH & SAFETY

The appliance contains no asbestos and no substances have been used in the construction process that contravene the COSHH Regulations (Control of Substances Hazardous to Health Regulations 1988).

COMBUSTIBLE AND CORROSIVE MATERIALS

Do not store or use any combustible materials (paper, thinners, paints etc.) inside or within the vicinity of the appliance.

Chemically aggressive substances, can corrode the appliance and invalidate any warranty.

FITTING & MODIFICATIONS

Fitting the appliance and any controls to the appliance may only be carried out by a competent engineer in accordance with the current Gas Safety (Installation and Use) Regulations.

Flue systems must not be modified in any way other than as described in the fitting instructions. Any misuse or unauthorised modifications to the appliance, flue or associated components and systems will invalidate the warranty. The manufacturer accepts no liability arising from any such actions, excluding statutory rights.

SERVICING

Advise the user to have the system serviced annually by a competent, qualified engineer (such as British Gas or other CORGI registered personnel) using approved spares, to help maintain the economy, safety and reliability of the appliance.

IMPORTANT - The service engineer must complete the Service Record on the Benchmark Checklist after each service.

INSTALLATION REGULATIONS

Current Gas Safety (Installation & Use) Regulations:

All gas appliances must be installed by a competent person in accordance with the above regulations. Failure to install appliances correctly could lead to prosecution.

The appliance must be installed in accordance with, and comply to, the current: Gas Safety Regulations, IEE Regulations, Building Regulations, Building Standards (Scotland) (Consolidation), Building Regulations (Northern Ireland), local water by-laws, Health & Safety Document 635 (The Electricity at Work Regulations 1989) and any other local requirements.

British Standards:

The relevant British Standards should be followed, including:

BS7074:1 : Code of practice for domestic and hot water supply

BS6891 : Installation of low pressure gas pipework up to 28mm (R1)

BS5546 : Installation of gas hot water supplies for domestic purposes

EN:12828 : Central heating for domestic premises
BS5440:1 : Flues and ventilation for gas appliances of rated heating not exceeding 70kW (net) : Flues

BS5440:2 : Flues and ventilation for gas appliances of rated heating not exceeding 70kW (net) : Air Supply

BS7593 : Treatment of water in domestic hot water central heating systems

BS 6798 : Installation of gas fired boilers of rated input up to 70kW (net)

Where no specific instruction is given, reference should be made to the relevant British Standard codes of Practice.

L.P.G. Installation:

An appliance using L.P.G. must not be installed in a room or internal space below ground level unless one side of the building is open to the ground.

Timber framed buildings:

Where the boiler is to be fitted to a timber framed building the guidelines laid down in BS5440: Part 1 and IGE "Gas Installations in Timber Frame Buildings" should be adhered to.

Potable water:

All seals, joints and compounds (including flux and solder) and components used as part of the secondary domestic water system must be approved by WRAS.

IMPORTANT: ARTIFICIALLY SOFTENED WATER MUST NOT BE USED TO FILL THE CENTRAL HEATING SYSTEM

STANDARD PACKAGE:

- A - Wall hung gas fired condensing boiler for central heating and indirect domestic hot water
- B - Wall plate
- C - Hardware literature pack (see check list)
- D - Tail pipes - water
- E - Bottom Panel

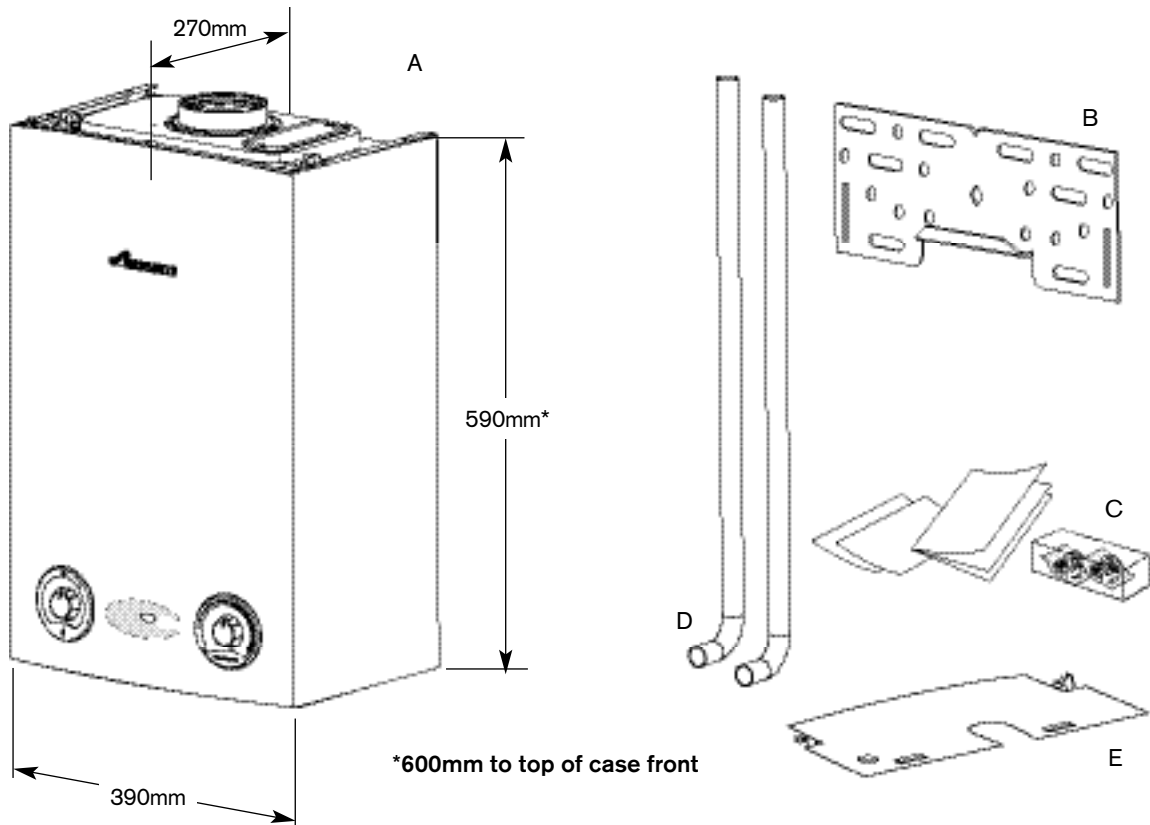

Check List

Hardware/Literature pack

Item	Qty
Greenstar Ri Installation/Serviceing Instructions.....	1
Users Instructions	1
Sealing Pack	1
Compression Nut 22mm	3
Compression Ring 22mm	3
Elbow Assembly Pack	1
Elbow Assembly	1
Fibre Washer	1
Environment 2010 Installer Leaflet	1
Environment 2010 Art Leaflet	1
Irish Guidelines Leaflet	1
Consumer Guarantee Card	1
Warranty Return Envelope	1

SPECIFICATIONS:

- Pre-wired and pre-plumbed
- Galvanised steel inner frame
- Digital control system
 - Automatic ignition
- Direct burner ignition electrodes
- Built-in frost thermostat
- Built-in fault finding diagnostics
- Modulating automatic gas valve
- Combustion air fan with speed regulator
- CH temperature sensor & control
- External pump anti-seizure protection
- Flue gas temperature limiter
- Condensate trap & syphon

DESCRIPTION	UNIT	NATURAL GAS				L.P.G.			
		12Ri	15Ri	18Ri	24Ri	12Ri	15Ri	18Ri	24Ri
Central Heating									
Max. rated heat output net 40/30°C	KW	12.85	16.06	19.28	25.67	12.85	16.06	19.28	25.67
Max. rated heat output net 50/30°C	KW	12.74	15.92	19.11	25.45	24.74	15.92	19.11	25.45
Max. rated heat output net 80/60°C	KW	12.0	15.0	18.0	24.0	12.0	15.0	18.0	24.0
Max. rated heat input net	KW	12.32	15.40	18.48	24.62	12.32	15.40	18.48	24.62
Max. flow temperature	°C	82	82	82	82	82	82	82	82
Max. permissible operating pressure	bar	2.5	2.5	2.5	2.5	2.5	2.5	2.5	2.5
Gas flow rate - Max. 10 minutes from lighting									
Natural Gas G20	m ³ /h	1.3	1.63	1.96	2.6	-	-	-	-
Propane Gas (LPG)	kg/h	-	-	-	-	0.96	1.20	1.44	1.91
Flue									
Flue Gas Temp. 80/60°C, rated min. load	°C	62/56	66/58	70/60	78/63	62/57	66/59	71/61	79/64
Flue Gas Temp. 40/30°C, rated min. load	°C	41/33	44/33	48/34	54/35	43/35	46/36	49/37	55/38
CO ₂ level at max. rated heat output (after 30 mins)	%	9.8	9.8	9.8	9.8	11.0	11.0	11.0	11.0
CO ₂ level at min. rated heat output (after 30 mins)	%	9.2	9.2	9.2	9.2	10.5	10.5	10.5	10.5
NO _x - class		5	5	4	5	5	5	4	5
Condensate									
Max. condensation rate	l/h	0.93	1.2	1.5	2.0	0.7	0.9	1.2	1.5
pH value, approx.		4.8	4.8	4.8	4.8	4.8	4.8	4.8	4.8
Electrical									
Electrical power supply voltage	AC...V	230	230	230	230	230	230	230	230
Frequency	Hz	50	50	50	50	50	50	50	50
Max. power consumption + pump	W	50	50	50	50	50	50	50	50
General Data									
SEDBUK	band	A	A	A	A	A	A	A	A
Appliance protection rating	IP	20	20	20	20	20	20	20	20
Permissible ambient temperatures	°C	0-50	0-50	0-50	0-50	0-50	0-50	0-50	0-50
Nominal capacity of appliance	l	1.1	1.1	1.1	1.1	1.1	1.1	1.1	1.1
Noise output level	dB(A)	39	42.7	43.7	41	39	42.7	43.7	41
Packaged boiler weight	kg	31	31	31	31	31	31	31	31
Total boiler weight	kg	27.4	27.4	27.4	27.4	27.4	27.4	27.4	27.4
Lift weight	kg	22.6	22.6	22.6	22.6	22.6	22.6	22.6	22.6
SEDBUK	%	90.1	90.1	90.1	90.2	91.4	91.4	91.4	92.0

LAYOUT & COMPONENTS

The diagram opposite shows the controls in the servicing position and excludes the outer case, inner covers and fascia panel.

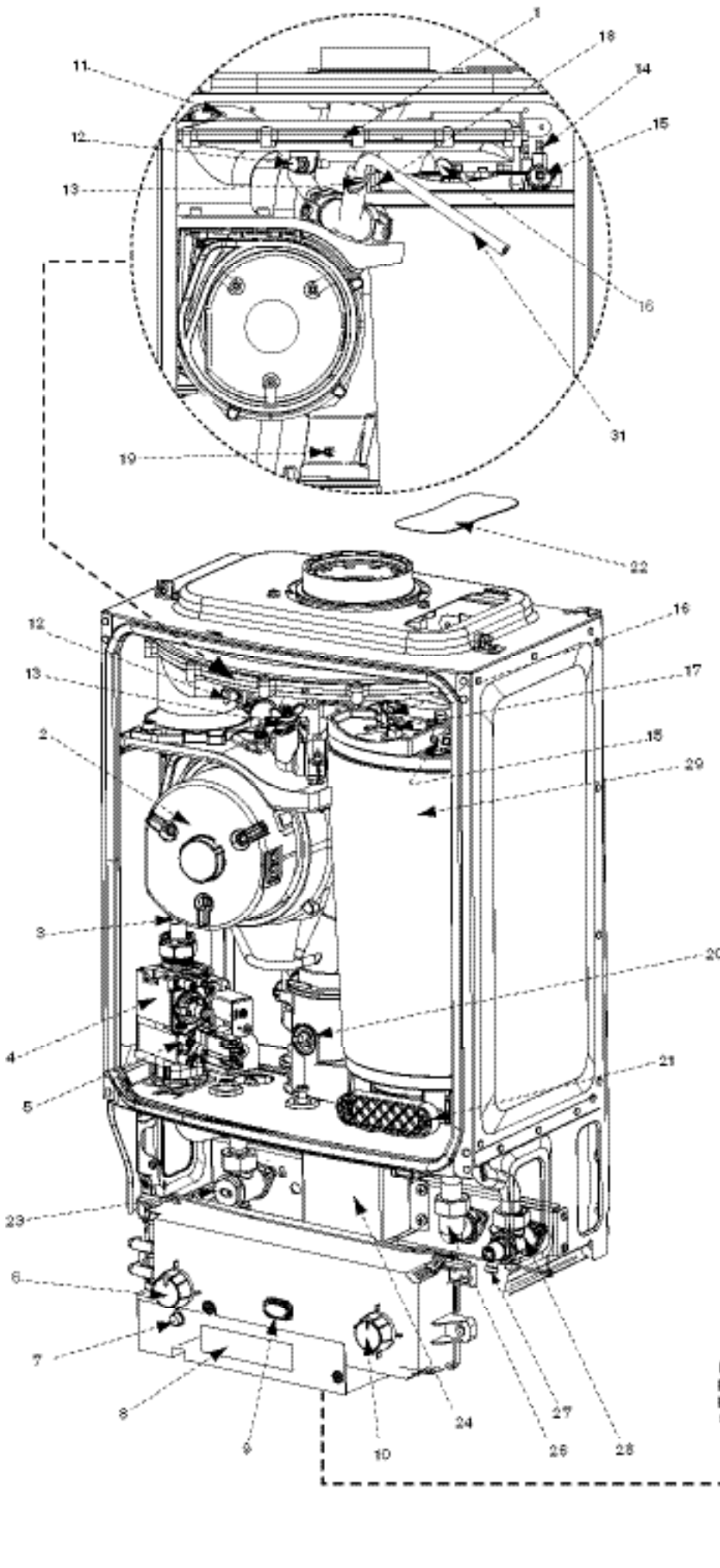

- 1 AIR / GAS MANIFOLD
- 2 FAN
- 3 AIR / GAS ADJUSTMENT SCREW
- 4 GAS VALVE
- 5 INLET PRESSURE TEST POINT
- 6 BOILER POWER SWITCH
- 7 FLAME INDICATOR (GREEN)
- 8 COVER FOR EXTERNAL WIRING CONNECTIONS
- 9 POWER AND FAULT INDICATOR (BLUE)
- 10 BOILER THERMOSTAT AND RESET KNOB
- 11 FLUE PRESSURE SWITCH
- 12 FAN PRESSURE TEST POINT
- 13 MANUAL VENT POINT
- 14 IGNITION AND FLAME SENSE ELECTRODES
- 15 OVER-HEAT THERMOSTAT
- 16 FLAME VIEWING MIRROR (REPLACED BY RETAINING BRACKET ON LATER APPLIANCES)
- 17 SECURING NUT, AIR / GAS MANIFOLD CLAMP
- 18 SENSOR - BOILER FLOW
- 19 FLUE AIR PRESSURE SWITCH CONNECTION
- 20 FLUE OVERHEAT THERMOSTAT
- 21 ACCESS POINT FOR CLEANING HEAT EXCHANGER
- 22 REMOVABLE TOP CASE PANEL FOR SERVICING
- 23 GAS INLET CONNECTION 22mm COMPRESSION
- 24 TRAP / SYPHON
- 25 TRAP / SYPHON OUTLET CONNECTION (3/4" PLASTIC PIPE)
- 26 FLOW CONNECTION 22mm COMPRESSION
- 27 DRAIN POINT
- 28 RETURN CONNECTION 22mm COMPRESSION
- 29 HEAT EXCHANGER
- 30 GAS COCK (ACCESS POINT)
- 31 SILICONE TUBE (USE TO VENT AIR FROM HEAT EXCHANGER)

IMPORTANT: All the following Pre-Installation sections must be read and requirements met before starting boiler or flue installation.

CAUTION: ISOLATE THE MAINS SUPPLIES BEFORE STARTING ANY WORK AND OBSERVE ALL RELEVANT SAFETY PRECAUTIONS.

CLEANING PRIMARY SYSTEMS

IMPORTANT: Debris from the system can damage the boiler and reduce efficiency. Failure to comply with the guidelines for the use of water treatment with the appliance will invalidate the appliance warranty.

BEFORE CLEANING THE SYSTEM:

ENSURE THE SYSTEM AND PIPEWORK IS IN GOOD WORKING ORDER

KEEP THE EXISTING BOILER/ CIRCULATING PUMP WHERE POSSIBLE OR USE A POWER FLUSHING MACHINE TO AID THE CLEANSING PROCEDURE BEFORE INSTALLING A NEW BOILER.

CLEANING THE PRIMARY SYSTEM:

IMPORTANT: ARTIFICIALLY SOFTENED WATER MUST NOT BE USED TO FILL THE CENTRAL HEATING SYSTEM

- Fill the system with cold water and check for leaks.
- Open all drain cocks and drain the system.
- Close drain cocks and add a suitable flushing agent at the correct strength for the system condition in accordance with the manufacturer's instructions.
- Circulate the flushing agent before the boiler is fired up.
- Run the boiler/system at normal operating temperature as directed by the manufacturer of the flushing agent.
- Drain and thoroughly flush the system to remove the flushing agent and debris.



ELECTRIC SUPPLY:

- Supply: 230V - 50Hz, 50 watts not including pump.
- Cable: PVC insulated 0.75mm² (24 x 0.2mm) temperature rated to 90°C.
- External 3A fuse to BS1362.
- The appliance must be earthed.
- Mains supply to the boiler and system wiring centre must be through one common fused double pole isolator situated adjacent to the appliance.
- Wiring must comply with IEE wiring regulations and any local regulations which may apply to fixed wiring to a stationary appliance.
- This appliance must not be connected to a three phase supply.



GAS SUPPLY:

- Boilers using NG must be connected to a governed meter.
- LPG boilers must be connected to a regulator.
- Installation and connection of the gas supply to the boiler must be in accordance with BS6891.
- The meter or regulator and pipework to the meter must be checked, preferably by the gas supplier, to ensure it is in good working order and can meet the gas flow and pressure requirements in addition to the demand from any other appliance being served. This does not include the pipework from the meter to the boiler.

18 & 24 Ri MODELS

- Under no circumstances should the size of the gas supply pipe be less than 22mm.

GAS SUPPLY PIPE SIZING:

12 & 15 Ri MODELS

Provided that the correct gas supply working pressure and gas rate can be achieved (see technical data table page 4 commissioning section, page 30, also refer to BS 6891)

Then it may be possible to reduce the gas supply pipe diameter to 15mm.

Generally speaking, the appliance would need to be within 3 to 4 metres of the gas meter. However, this will depend on the distribution pipe size and route.

S PLAN LAYOUT

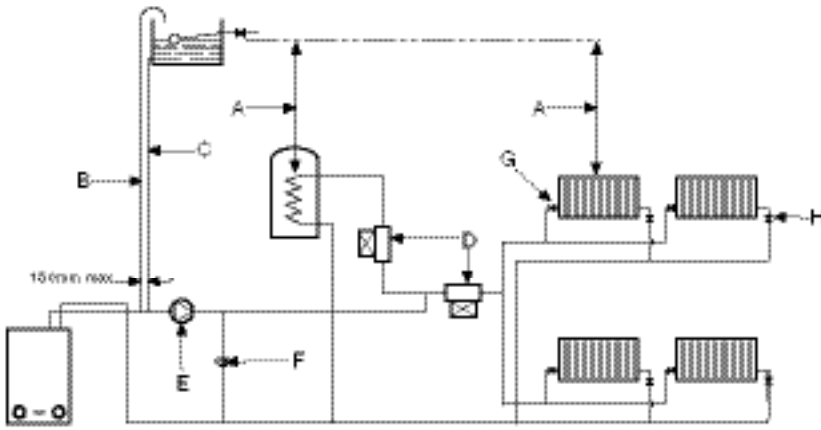

Y PLAN LAYOUT

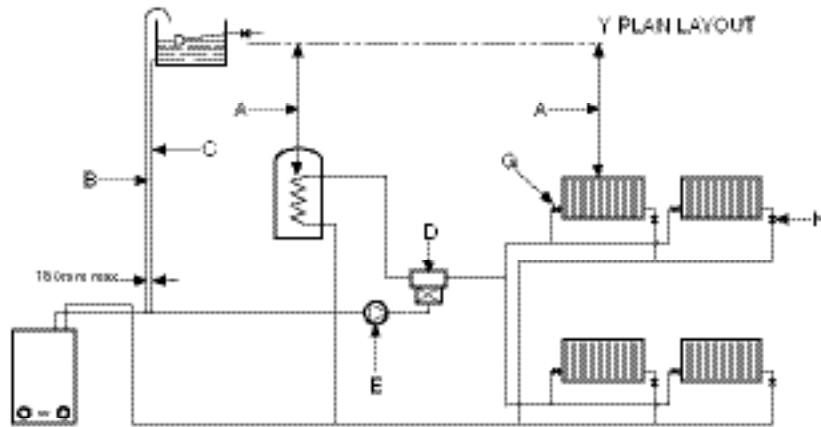

SEALED SYSTEM LAYOUT

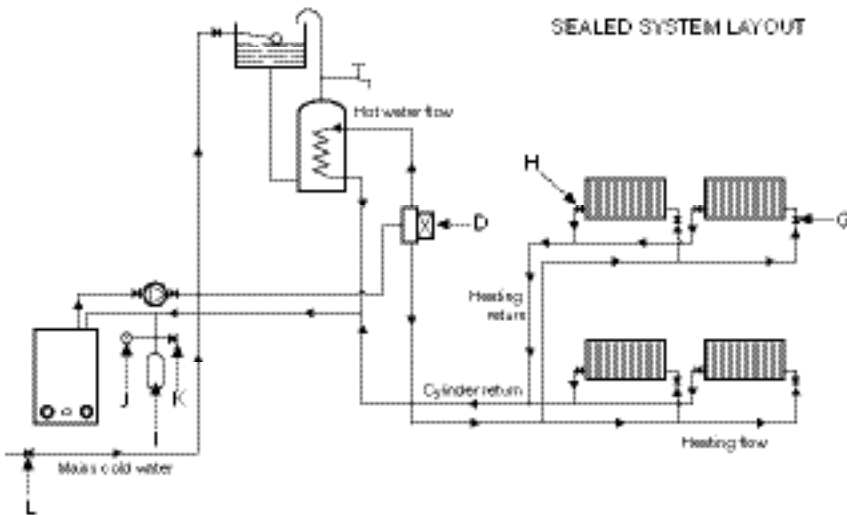

SYSTEM FILL

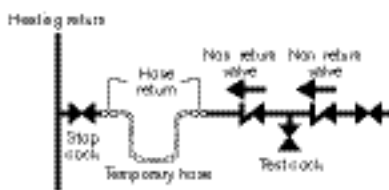

SYSTEM MAKE UP

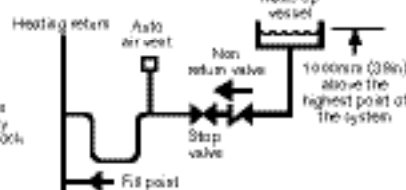

PLASTIC PIPEWORK & UNDER FLOOR HEATING:

- Any plastic pipework must have a polymeric barrier with 600mm (minimum) length of copper pipe connected to the boiler.
- Plastic pipework used for underfloor heating must be correctly controlled with a thermostatic blending valve limiting the temperature of the circuits to approx. 50°C.

CONNECTIONS/VALVES:

- All system connections, taps and mixing valves must be capable of sustaining a pressure up to 3 bar.
- Radiator valves should conform to BS2767:10.
- All other valves should conform to BS1010.
- On new installations TRV's must be used on all radiators except where a room thermostat is sited. On all installations TRV's should at least be fitted in the sleeping areas. See note below on open radiator/bypass
- A drain cock is required at the lowest point on the system.
- An air vent is required at the highest point on the system.

S and Y PLAN SYSTEM:

NOTE: Generally a bypass is not necessary on a Y plan system as one of the ports is open to flow.

A Static Head - Minimum static head 250mm measured from the highest point in the heating system (top surface of the appliance or highest point in the heating system) to the water level in the feed and expansion tank.

- B Heating Vent (22mm minimum)
- C Primary Cold Feed (15mm minimum)
- D Diverter Valve and Zone Valves
- E Pump, max power 90 Watts
- F Automatic Bypass
- G Radiator Valve (Flow)
- H Lockshield Valve (Return)

NOTE: A drain cock should be fitted at the lowest point of the heating circuit and beneath the appliance.

FULLY PUMPED SEALED SYSTEM:

- The CH sealed system must be filled using a WRAS approved filling loop or comply with the diagram opposite for System fill
- Do not use galvanised pipes or radiators.

- I Expansion Vessel
- J Pressure Gauge
- K 3 Bar Pressure Relief Valve
- L Stop Valve Fixed Cylinder Type or sealed systems approved connection

NOTE: A drain cock should be fitted at the lowest point of the heating circuit and beneath the appliance.

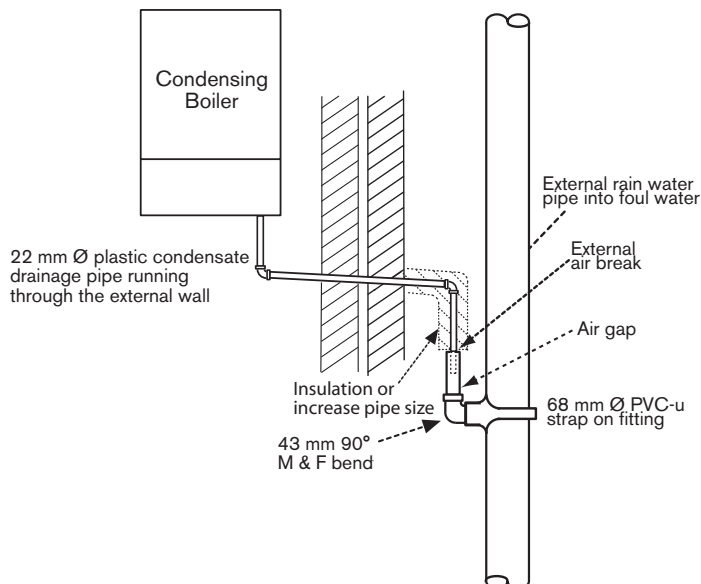
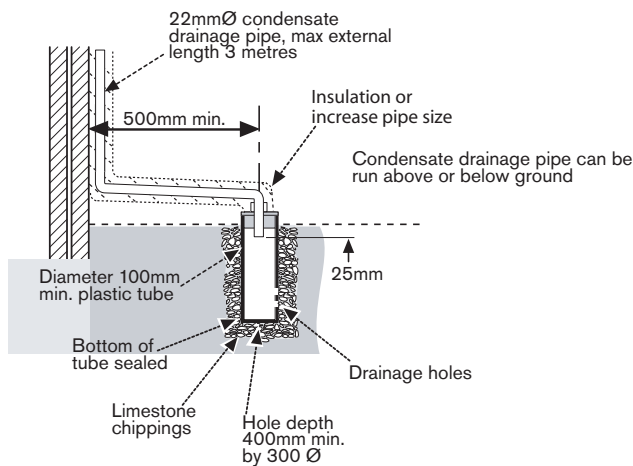
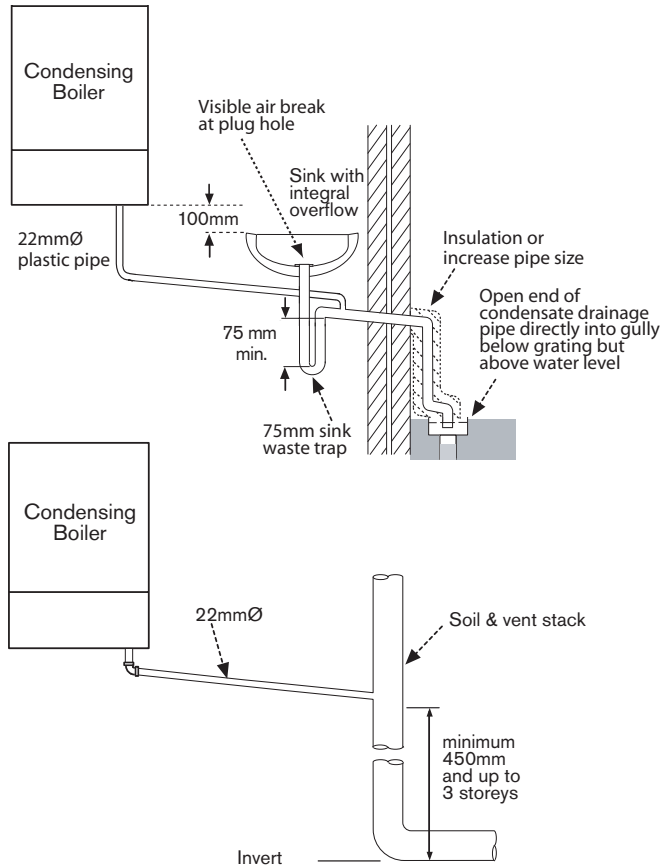

IMPORTANT:

- Ensure there are no blockages in the pipe run
- Care should be taken when siting a soak-away to avoid obstructing existing services
- Condensate waste must not be terminated into a septic tank or cesspit

CONDENSATE PIPEWORK:

- The condensate pipe must be a minimum of 22 mm Ø plastic pipe.
- The condensate pipework must fall at least 50 mm per metre towards the outlet and should take the shortest practicable route.
- The pipework must follow one of the options shown opposite.
- Wherever possible the condensate discharge pipe work should be routed and terminated internally. Should this not be possible, and the only available route is external, the following conditions should be observed:

External pipe work

- Pipe work length should be kept to a minimum and the route as vertical as possible.
- Where pipe work is subjected to extreme cold or wind chill, a weather proof insulation should be used.
 - Alternatively the condensate pipework could be increased to a minimum diameter of 32 mm without the requirement to insulate.

Condensate soakaway

The condensate drainage pipe may be run above or below the ground to the soakaway. The example shown opposite runs above ground level.

The soakaway must use a 100mm diameter plastic tube with two rows of three 12 mm holes on 25 mm centres and 50 mm from the bottom of the tube. The holes must face away from the house.

The tube must be surrounded by at least 100 mm of limestone chippings to a depth of 400mm.

Fitting an external air break

Use the situation opposite when a rain water down pipe is used to dispose of condensate and the down pipe goes directly into an existing sewer that carries both rainwater and foul water.

An air break must be installed in the 32/43 mm pipework, between the boiler condensate outlet and the drainpipe, outside the property, to avoid flooding during adverse weather conditions.

SERVICING CLEARANCES VENTED COMPARTMENT

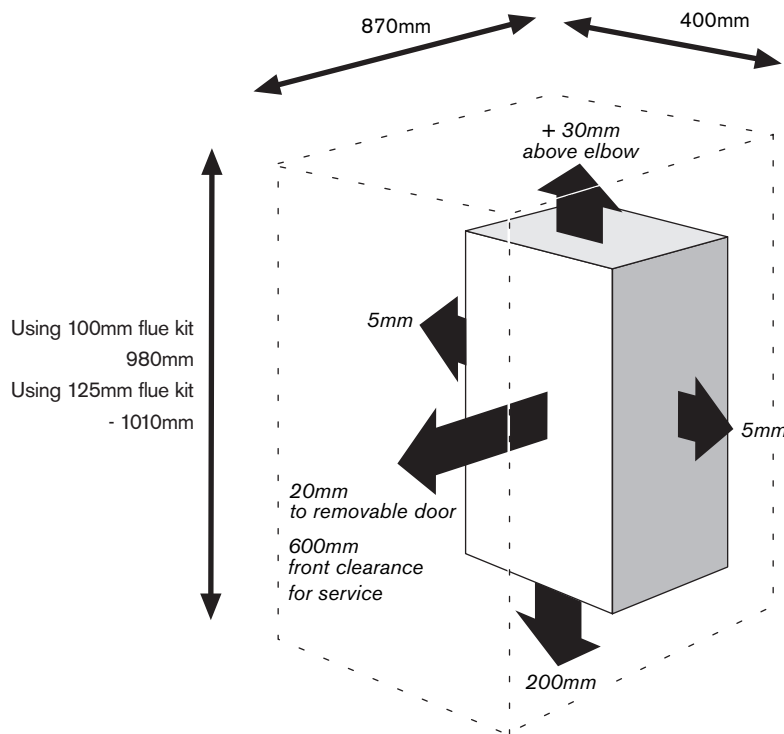

PRE-
INSTALLATION

VENTILATION FREE COMPARTMENTS INSTALLATION CLEARANCES

Ventilation Free Compartment Installation Clearances			
The suggested total unventilated compartment minimum clearances are:			
Side	Above	Below	Front (to removable door)
400mm	170mm approx. (30mm above the elbow)	200mm	100mm

(Note: Top and bottom clearances must not be reduced below these values as they are the minimum required for servicing).

If Side Clearances are Reduced			
If total side clearance is reduced to: **	Then overall height clearances must be increased to (approx): *	OR	Front clearance (to removable door) must be increased to:
350mm	441mm		129mm
300mm	523mm		161mm
250mm	617mm		200mm
200mm	727mm		243mm
150mm	856mm		295mm
100mm	1012mm		358mm
50mm	1202mm		434mm

If Front Clearance is Reduced			
If front clearance (to removable door) is reduced to:	Then overall height clearances must be increased to (approx): *	OR	Total side clearance must be increased to: **
50mm	511mm		505mm
25mm	596mm		569mm

BOILER LOCATION &

CLEARANCES

This boiler is only suitable for installing internally within a property at a suitable location onto a fixed, rigid surface at least the same size as the boiler and capable of supporting the boiler weight.

COMPARTMENTS:

Follow the requirements of BS6798 and BS5440 Part 2 and note:

- Minimum clearances must be maintained
- An access door is required to install, service and maintain the boiler and any ancillary equipment
- If fitting the boiler into an airing cupboard use a non-combustible material (which can be perforated with holes upto 13mm diameter) to separate the boiler from the airing space.

BOILER CLEARANCES:

The diagram opposite shows the minimum space required to install and service the boiler.

If a boiler is installed in a compartment with clearances less than shown in the tables opposite, ventilation is required. Refer to tables below for ventilation requirements.

Ri		
Vent position	To room or internal space	Direct to outside
High level	Minimum free area 122 cm ²	Minimum free area 61 cm ²
Low level	Minimum free area 122 cm ²	Minimum free area 61 cm ²

BOILER CLEARANCES - UNVENTILATED COMPARTMENTS:

The tables opposite show the options for the minimum space required to install and service the boiler inside an unventilated compartment.

* **NOTE:** These are the combined top & bottom clearances excluding the appliance.

** **NOTE:** These are the combined left & right clearances excluding the appliance.

BOILER LOCATION &

CLEARANCES

BATHROOMS:

The boiler must be installed outside the shaded areas shown opposite.

Additional RCD (Residual Current Device) protection may be required.

Refer to the latest IEE wiring regulations.

(See Technical Data for IP ratings.)

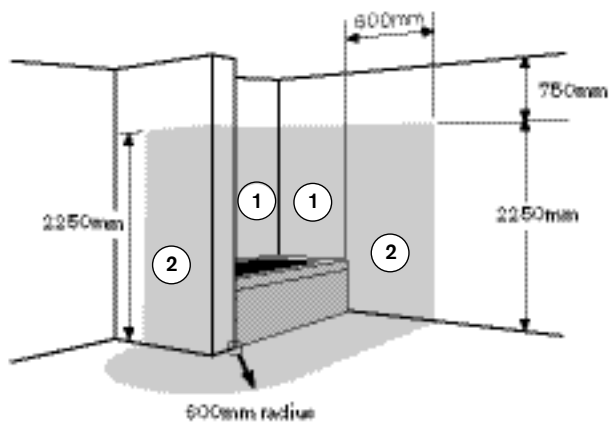
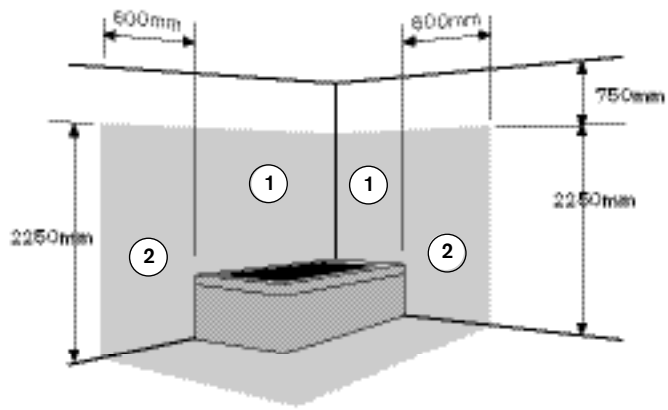

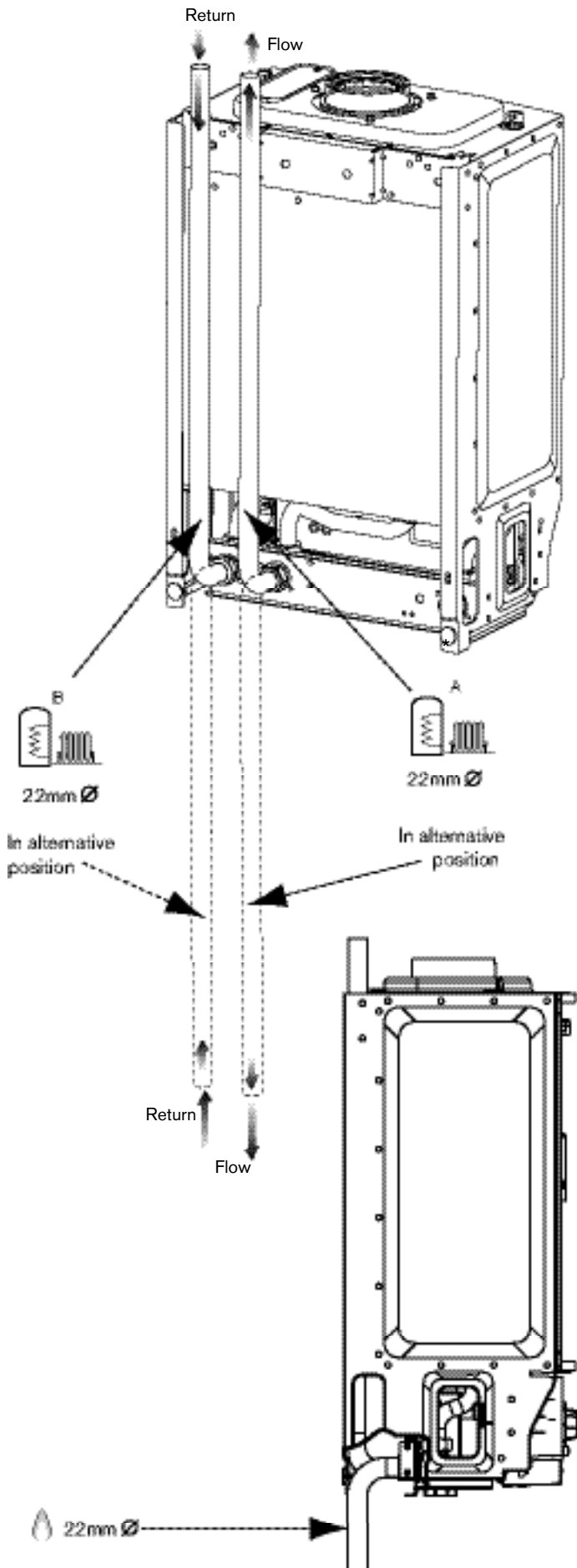

CONNECTIONS:

Heating System: 22mm compression fittings*
Gas: 22mm

Use the 22mm copper pipes (A & B) provided with the appliance, as shown in the diagram opposite.
Use the fittings supplied in the Lit/Hardware pack.

- If the flow and return pipes are to be run behind the appliance it may be an advantage to connect the pipes before hanging on the wall especially if space is limited.

FLUE OPTIONS

The Greenstar series has the option of two horizontal RSF (60/100 telescopic and 80/125) flue systems and two vertical RSF (60/100 or 80/125) flue systems:

The systems have different maximum flue lengths

This page shows various fluing options with the straight flue lengths required to achieve the maximum flue length. Note that:

- each 90° bend used is equivalent to 2 metres of straight flue
- each 45° bend used is equivalent to 1 metre of straight flue

NOTE: Plume management kits are available for the 60/100 horizontal flue option. Refer to the manual supplied with the Plume management kits for complete installation instructions

Telescopic horizontal flue assembly

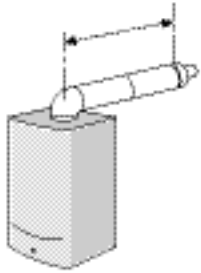

	Maximum telescopic flue length	
	100mmØ	125mmØ
12 Ri	570mm	1,070mm
15 Ri	570mm	1,070mm
18 Ri	570mm	1,070mm
24 Ri	570mm	1,070mm

Horizontal flue extension

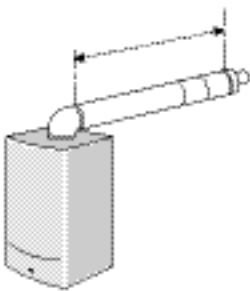

	Maximum total flue length	
	100mmØ	125mmØ
12 Ri	4,600mm	13,000mm
15 Ri	4,600mm	13,000mm
18 Ri	4,600mm	13,000mm
24 Ri	4,600mm	13,000mm

High level horizontal flue

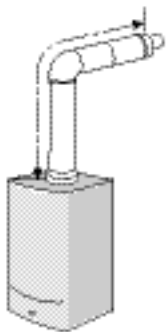

	Maximum total flue length	
	100mmØ	125mmØ
12 Ri	4,600mm	13,000mm
15 Ri	4,600mm	13,000mm
18 Ri	4,600mm	13,000mm
24 Ri	4,600mm	13,000mm

Horizontal flue with 2x90° bends

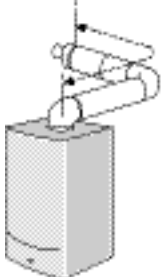

	Maximum total flue length	
	100mmØ	125mmØ
12 Ri	2,600mm	11,000mm
15 Ri	2,600mm	11,000mm
18 Ri	2,600mm	11,000mm
24 Ri	2,600mm	11,000mm

High level horizontal flue with 2x90° bends

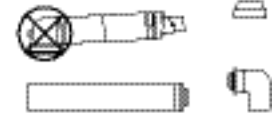

	Maximum total flue length	
	100mmØ	125mmØ
12 Ri	2,600mm	11,000mm
15 Ri	2,600mm	11,000mm
18 Ri	2,600mm	11,000mm
24 Ri	2,600mm	11,000mm

High level horizontal flue with 3x90° bends

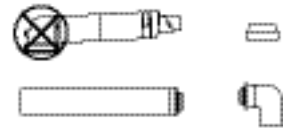

	Maximum total flue length	
	100mm,Ø	125mmØ
12 Ri	N/A	9,000mm
15 Ri	N/A	9,000mm
18 Ri	N/A	9,000mm
24 Ri	N/A	9,000mm

Vertical balanced flue assembly



	Maximum total flue length	
	100mmØ	125mmØ
12 Ri	6,400mm	15,000mm
15 Ri	6,400mm	15,000mm
18 Ri	6,400mm	15,000mm
24 Ri	6,400mm	15,000mm

Vertical balanced flue system with 2x45° bends



	Maximum total flue length	
	100mm,Ø	125mmØ
12 Ri	4,400mm	13,000mm
15 Ri	4,400mm	13,000mm
18 Ri	4,400mm	13,000mm
24 Ri	4,400mm	13,000mm

Vertical balanced flue with 2x90° bends

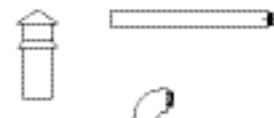

	Maximum total flue length	
	100mmØ	125mmØ
12 Ri	2,400mm	11,000mm
15 Ri	2,400mm	11,000mm
18 Ri	2,400mm	11,000mm
24 Ri	2,400mm	11,000mm

PRE-
INSTALLATION

- The flue must be fitted and terminated in accordance with the recommendations of BS5440 : Part 1.
 - The flue must not cause an obstruction.
 - Discharge and any noise from the flue outlet must not cause a nuisance.
 - Flue gases have a tendency to plume and in certain weather conditions a white plume of condensation will be discharged from the flue outlet. Where this could be a nuisance, for example, near security lighting, an alternate position should be found.
 - The air inlet/outlet duct and the terminal of the boiler must not be closer than 25mm to any combustible material.
- Detailed recommendations on protection of combustible materials are given in BS 5440: Part 1
- A protective terminal guard must be fitted if the terminal is 2m or less above a surface to which people have access. The guard must be spaced equally (minimum 50 mm) around the flue and fixed to the wall with plated screws. See Contact Information (inside front cover).

If plume management is utilised, the clearance from the flue air inlet to any opening can be decreased to 150mm in all cases, as long as the clearance from the flue outlet to any opening and is maintained as shown on this diagram

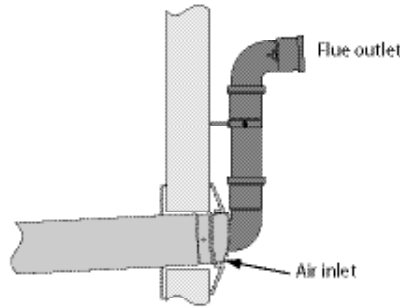

500mm clearance to any vertical structure on a roof, 600mm to another flue or 1500mm to an open flue.

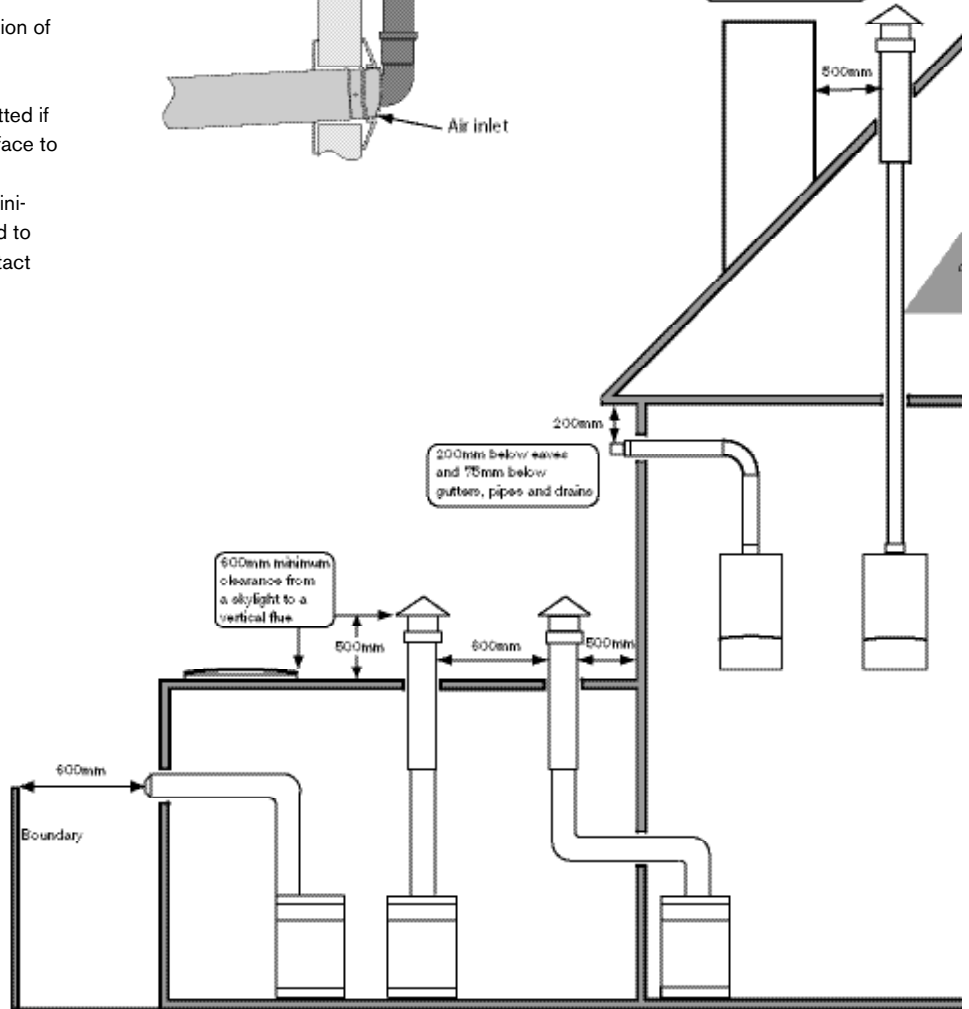

600mm distance to a boundary, unless it will cause a nuisance. BS 5440: Part 1 recommends that care is taken when siting terminals in relation to boundaries

Deduct one metre off the total flue length for every 45° bend used
Deduct two metres off the total flue length for every 90° bend used

The flue turret has a built-in angle of 3° to ensure that the condensate flows back to the boiler for safe disposal via the condensate waste pipe.
All horizontal flue sections must rise by 3° or at least 52mm for each metre away from the boiler to ensure condensate flows back into the boiler.

Vertical flue clearance 500mm to non-combustible building material, and 1500mm clearance to combustible building material

NOTES:

Plume management kits are available for 100mm horizontally terminated flues. Please refer to the installation instructions supplied with the plume management kits.

If plume redirection is utilised, the clearance from any opening must be increased in the direction of the plume to 1500mm.

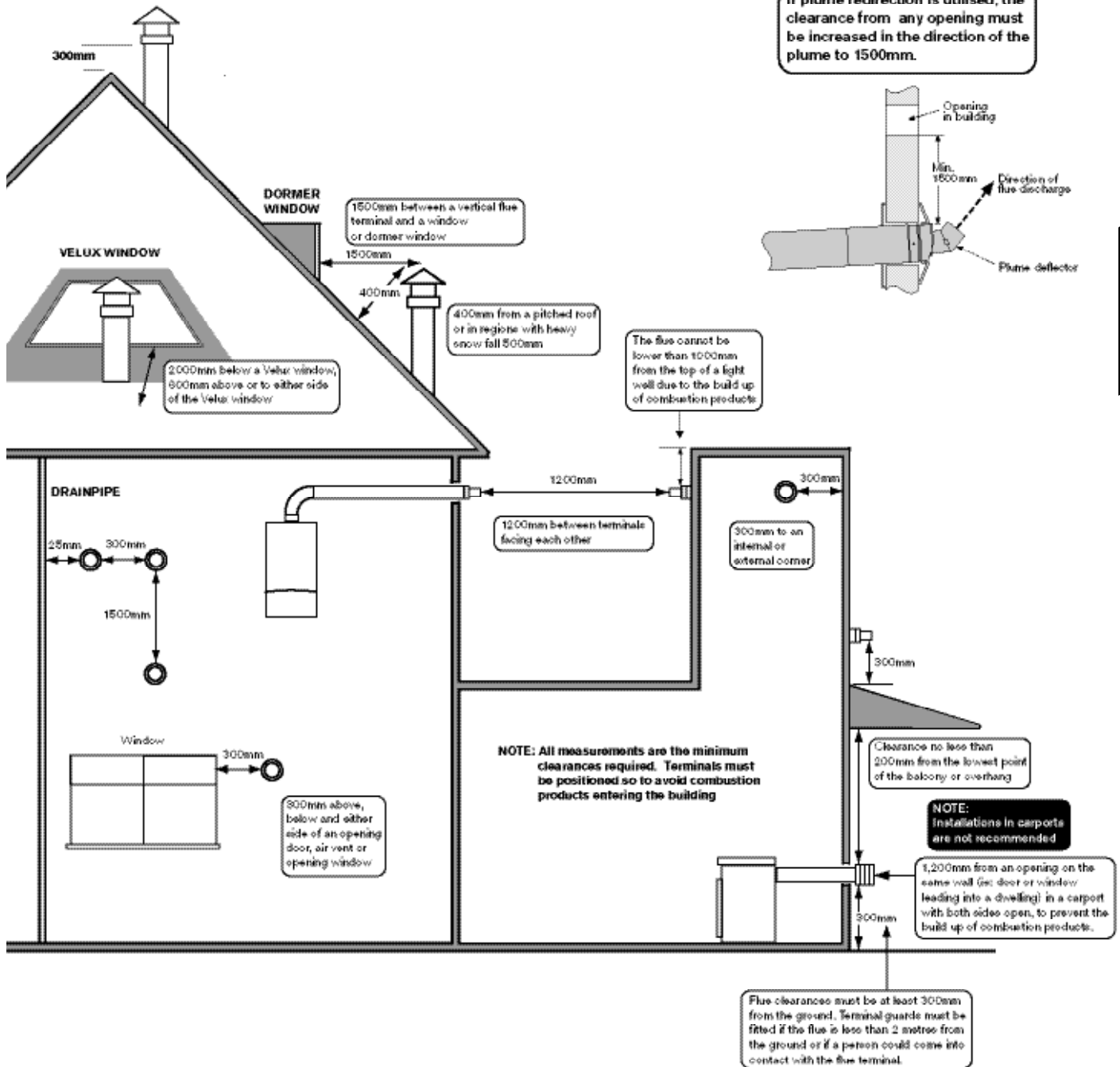
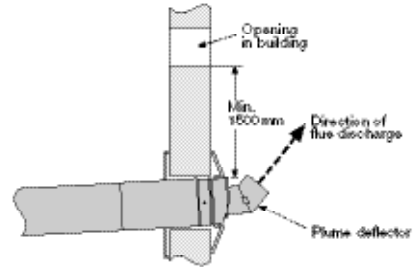

PRE-INSTALLATION

: All the previous Pre-Installation sections must be read and requirements met before starting boiler or flue installation.

UNPACKING THE BOILER

LIFTING AND CARRYING PRECAUTIONS:

- Lift only a manageable weight, or ask for help.
- When lifting or putting things down, bend the knees, and keep the back straight and feet apart.
- Do not lift and twist at the same time.
- Lift and carry objects close to the body

- A - Straps
- B - Outer carton
- C - Base tray
- D - Inner wrap and **wall template**
- E - Wall mounting plate
- F - Installer pack
- G - Base Panel
- H - 22mm pipes (2) (system flow and return)

IMPORTANT HANDLING INSTRUCTIONS

- It is advised that two people are used to carry the carton from the van to the point of delivery.
- Once the carton has been delivered, the outer carton is removed first. Care should be taken when releasing the straps. If a sharp implement is used make sure the outer carton is not pierced and that the implement is used in such a way so that it may not cause personal injury. All sharp objects must be covered or the blade retracted after use and put away in a safe place. The wall mounting plate, the two 22mm pipes and the Lit/Hardware pack are now removed making sure that no damage occurs to the internal wrap which doubles as the Wall Template. Care should be taken when lifting the boiler from the base and the proper technique for safe lifting of any heavy object should be strictly observed.

Additional requirements for roof space installation:

- The boiler should be first unpacked before ascending ladder to loft space.
- Two sets of steps should be used.
- Two people should share the lifting of the boiler up to the loft hatch, where the boiler is entered into the loft space tilted and slid on its back into the loft.

Once the appliance is removed from its packaging check the contents against the packing list.

Before installing appliance ensure system has been cleaned as explained on page 6.

INSTALLATION

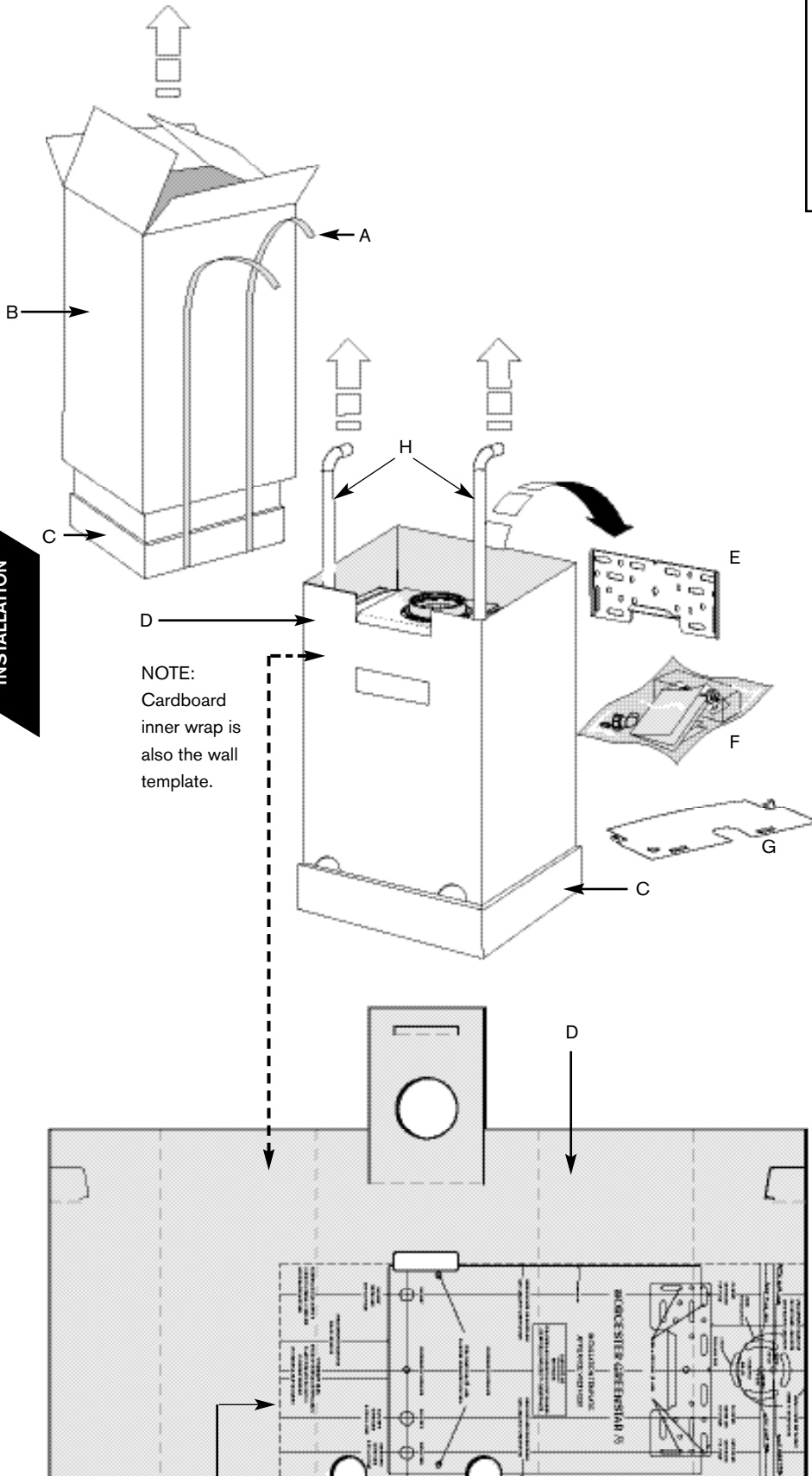

NOTE:
Cardboard
inner wrap is
also the wall
template.

NOTE: Carefully cut along perforated line to release wall template.

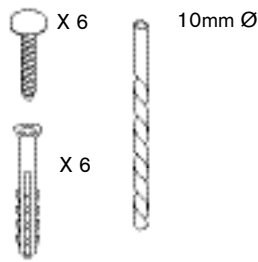

CAUTION:
Use appropriate mounting hardware to suit boiler weight and wall type.

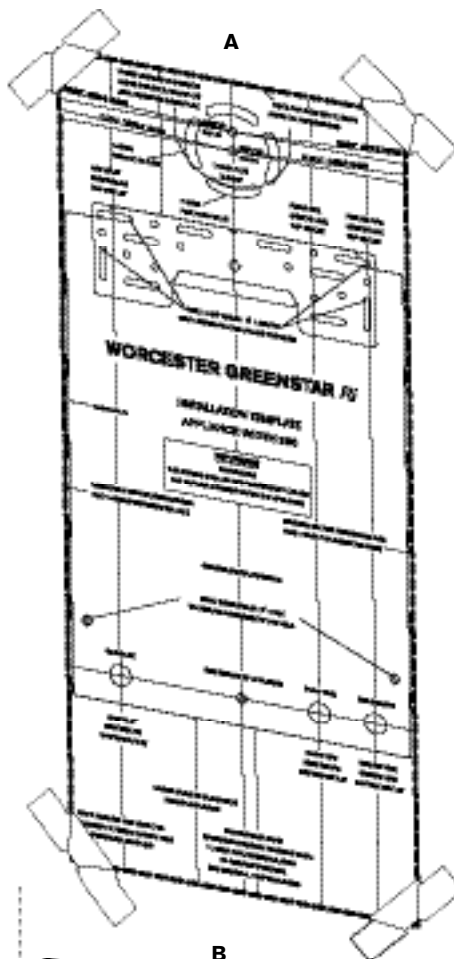

WALL MOUNTING PLATE

FLUE OPENING

CAUTION: Ensure there are no pipes, electric cables, damp proof courses or other hazards before drilling.

SAFETY:

All relevant safety precautions must be undertaken. Protective clothing, footwear, gloves and safety goggles must be worn as appropriate.

FIXING THE MOUNTING FRAME:

- The boiler template shows the relative positions of the flue and pipes to the boiler.
- Also clearances around the appliance.
- ▶ Fix the template to the wall in the desired position (A).
- ▶ Mark the clearance around the boiler and the position of gas and system pipes (2) and (3).
- ▶ Drill 4 holes for the wall mounting plate through the template.
- ▶ Drill 2 holes for bottom fixing screws.
- ▶ Drill hole for flue duct through the wall.

NOTE: The template has been sized to allow for minimum clearances of 5mm sides, 200mm base and 30mm above a Ø100 flue elbow.

REAR FLUE OUTLET

- The drawing (B) opposite shows the boiler template with the flue centre lines of both the 100mm and 125mm flue systems.
- ▶ Mark centre-line of flue to be used (1).
- If a Ø100mm diameter flue is to be used, a 125mm diameter hole is required. However, if using the weather sealing collar by pushing it through from inside the property, then a 150mm diameter hole is required to accommodate this.
- The flue turret of the 100mm flue has an in-built 3° angle. If extensions are to be added then the complete flue must rise at an angle of 3°.
- The 125mm Ø flue system will require the flue to rise at an angle of 3°.
- ▶ Drill hole using a core drill or similar.

SIDE OUTLET:

- ▶ Mark from the centre line of the wall template to the wall which the flue will pass through (4).
- ▶ Allow for a rise of 52mm per metre length of flue, to give a 3° angle.
- ▶ Clear any debris from the site.

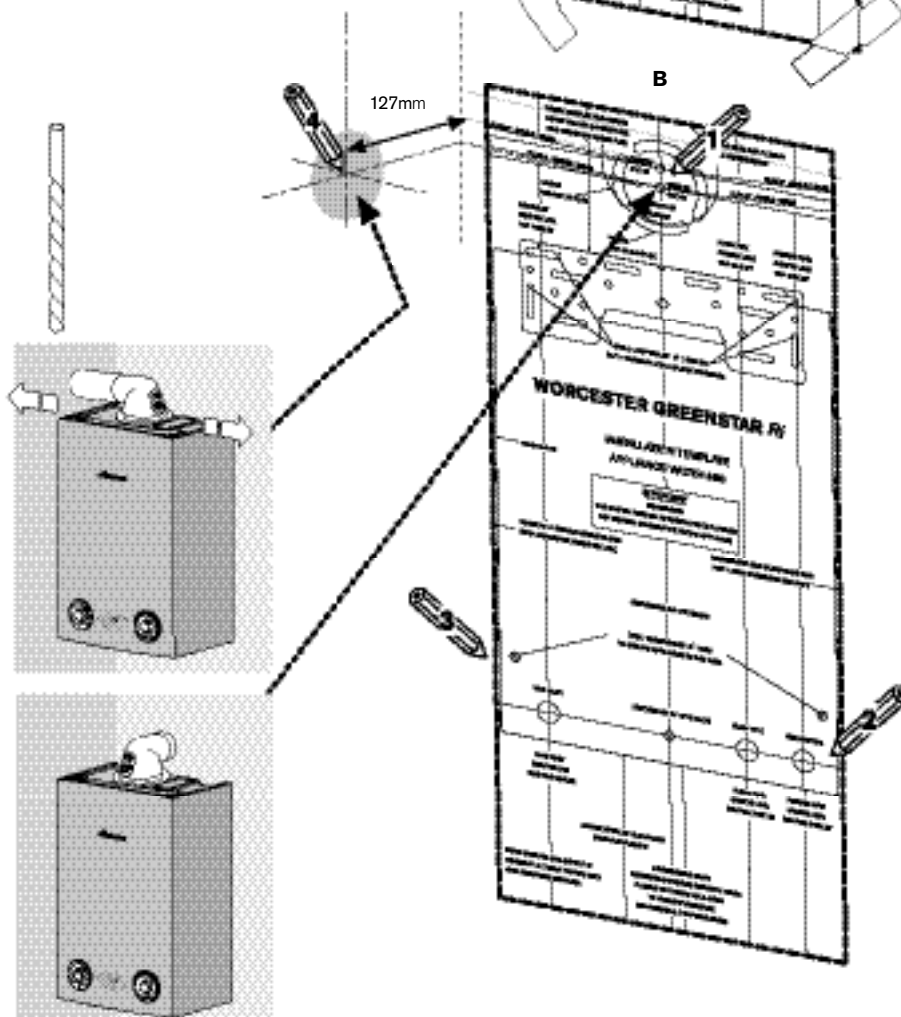

INSTALLATION

OUTER CASE REMOVAL

REMOVING OUTER CASE

1. Undo and remove 2 screws (A) securing boiler casing at the top of the appliance.
 2. Undo the 2 captive screws (B) securing boiler casing at the bottom of the appliance.
 3. Pull case upwards.
 4. Remove cardboard packing piece from appliance.
- ▶ With the outer case removed the appliance is suitable for a 1 man lift (<25kg).

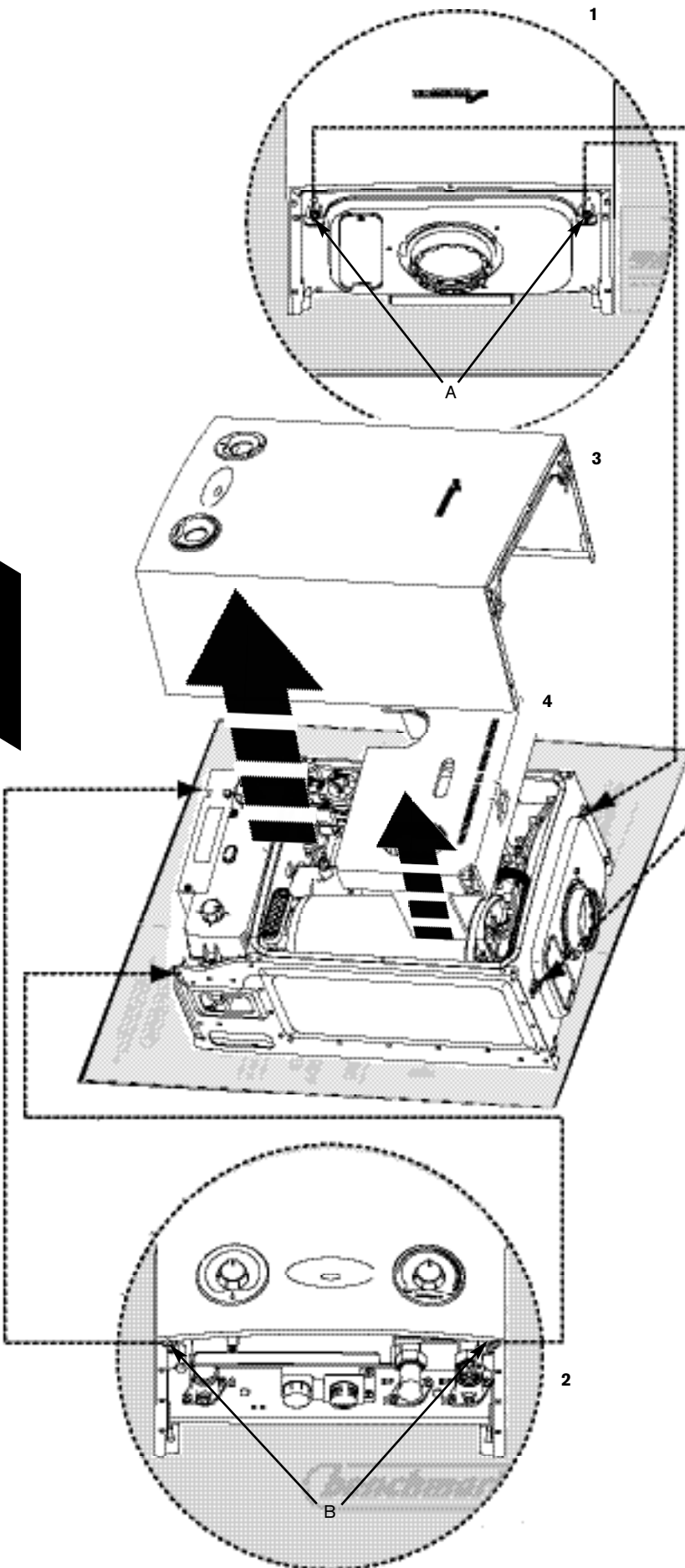

CAUTION: ISOLATE THE MAINS GAS SUPPLY BEFORE STARTING ANY WORK AND OBSERVE ALL RELEVANT SAFETY PRECAUTIONS.

CAUTION: Caps fitted to pipes must be removed before hanging the boiler.

GAS AND WATER CONNECTIONS:

- ▶ Remove template and secure the wall mounting plate to the wall with the fixings supplied.
- If there is greater than 600mm clearance below the appliance it is possible to fit the flow and return pipes, supplied, with the boiler installed on the wall.

If clearance is less than 600mm below the appliance it may be necessary to fit the flow and return pipes before hanging the appliance.

- A - flow (22mm)
- B - return (22mm)
- C - Gas inlet (22mm)

NOTE: The boiler is best lifted using the handling holes either side of the unit. Do not lift the boiler by the air gas manifold or control box.

- ▶ System pipes may be run vertically upwards behind the boiler or below it.

NOTE: If pipes require reducing in length this is best done before they are fitted to the boiler.

- ▶ Lift the boiler onto the wall plate and level using the feet (D) at the bottom rear of the boiler casing.
- ▶ Fit retaining screws through the boiler frame (E).
- ▶ Make connections to the heating system pipes.
- ▶ Connect the gas supply to the boiler gas cock 22mm compression fitting (pipe not supplied).

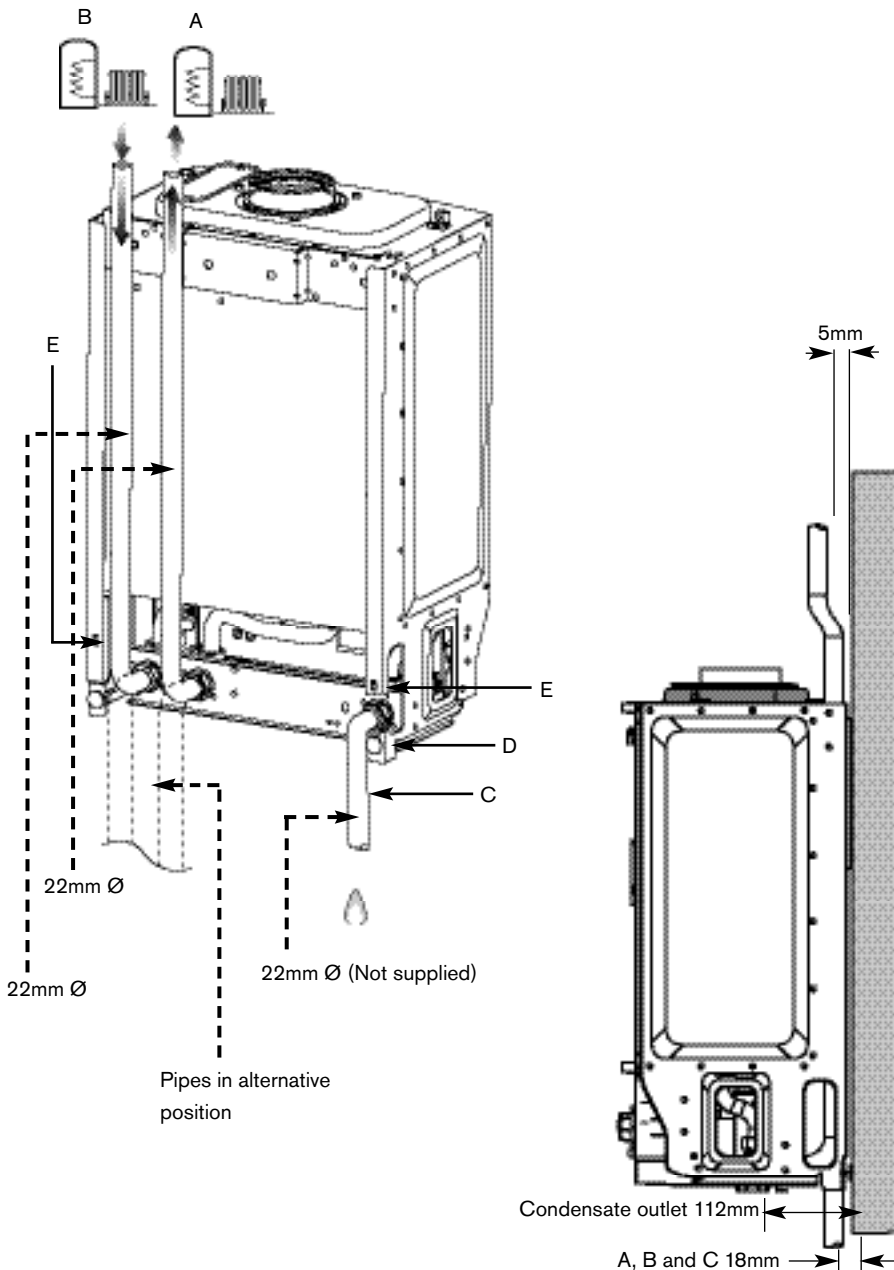
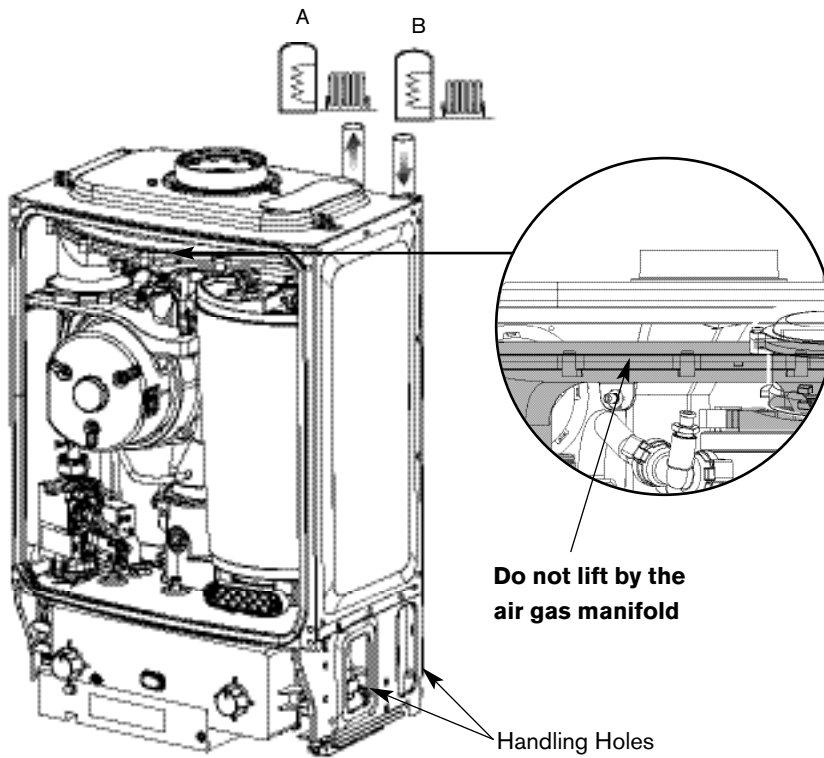

FLUE INSTALLATION

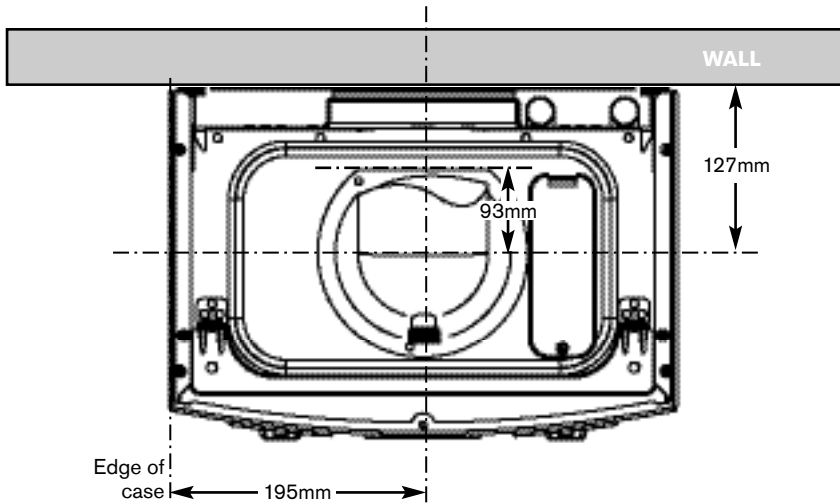

HORIZONTAL FLUE (60/100mm diameter)

For vertical flues and 80/125mm horizontal flues, please refer to separate instructions supplied with the flue kit.

NOTE: to ease assembly of flue components, apply silicone lubricant to sealing surfaces.

Basic instructions for the 60/100mm diameter flue are shown below.

MEASURING THE FLUE (Standard Flue):

- ▶ Measure from the outside wall to the centre line of the flue turret.
- ▶ Subtract 93mm from the length L to give the correct dimension to the flue elbow connection.
- ▶ If the length L falls within the telescopic range of 350 to 570mm, then no cutting will be required.
- ▶ If the required length is less than 350mm the standard telescopic flue can be modified, refer to section 3.
- ▶ If the required length is greater than 570mm, then flue extensions will have to be used. Refer to the 60/100 Horizontal Flue Instruction manual provided in the flue extension kit.

Adjusting the standard terminal length:

- 2 Extend tube (A) by withdrawing from tube (B) to achieve the flue length required, between 350- 570mm.

NOTE: Ensure that the TOP label of both sections are aligned before securing the two parts at the required length.

The flue terminal **MUST** be fitted with the 'TOP' label uppermost to allow the correct fit and use of the plume management system. Secure with screw provided and seal joint with the aluminium tape supplied.

Reducing the standard terminal length:

- 3 Remove securing screws (C) to detach the terminal assembly from the turret. Slide terminal section (B) from the terminal assembly and discard. To use terminal (A) without cutting remove the location lug (D) on the inner flue tube (E) and remove any burrs. To reduce the terminal length further:
- 4 Mark the length required for the terminal (F) as shown (min. 130mm) and cut square, taking care not to damage the tubes. Remove any burrs and chamfer the outer edge of the tubes to assist ease of connection and prevent seal damage.

NOTE: The aluminium tape is not required when reducing the terminal.

- ▶ After cutting, the end must be square and free from burrs to prevent damage to the flue seals.

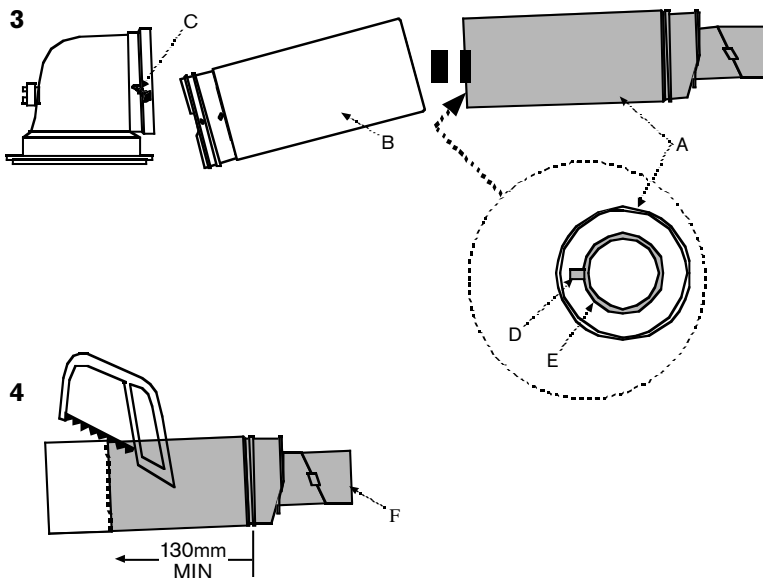
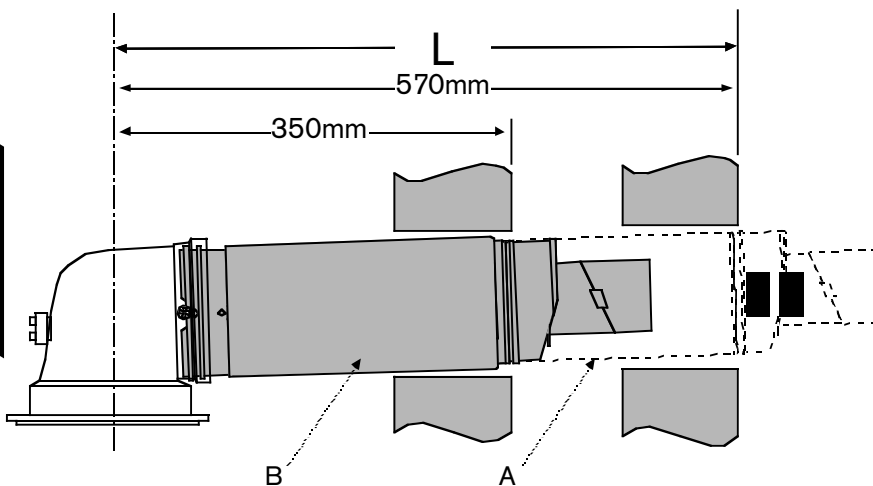

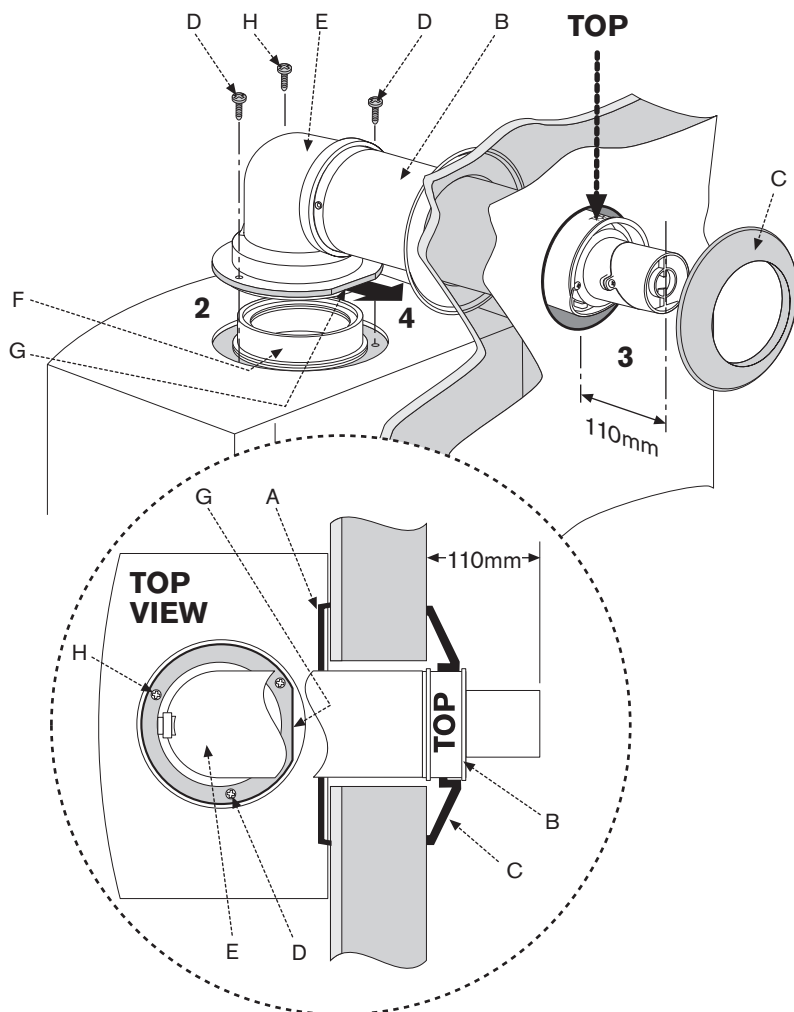
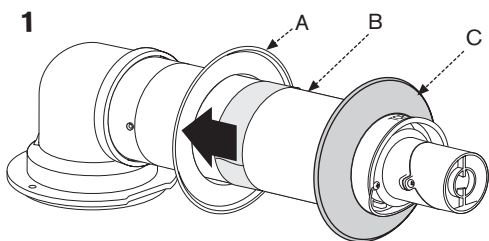

FLUE INSTALLATION

Installing the standard flue:

- 1 Set the flue length to the distance required, secure with screw and seal joint with the aluminium tape supplied. Slide the inner wall seal (A) onto the terminal (B) as shown.
If fitting from inside the building; slide the outer wall seal (C) onto the terminal (B) as shown.
- 2 Remove the three screws (D, H) around the flue outlet (F) on the boiler. Check the boiler flue seal is correctly seated. Apply silicone grease to the boiler flue seal.
- 3 Position terminal (B) through the flue opening in the wall to the outside of the building by the distance shown. The flue terminal **MUST** be fitted with the 'TOP' label uppermost to allow the correct fit and use of the plume management system.
- 4 Align the flue turret (E) to the boiler flue outlet (F) with flat (G) facing to the rear of the boiler. Push the flue turret (E) straight down into the boiler flue outlet (F).
For ease of assembly, locate screw (H) first and then fit screws (D) to secure flue turret (E).
If fitting from the outside of the building; slide the outer wall seal (C) onto the terminal (B) as shown.

NOTE:

For more information refer to the 60/100 Horizontal Flue kit Instruction Manual

FLUE TERMINAL PLUME RE-DIRECTION:

The flue discharge can be redirected allowing some plume management control, alternatively, a complete plume management system can be fitted to the flue terminal.

Redirecting the flue discharge:

- 1 Remove screws (A) and rotate the terminal end (B) through 180°.
DO NOT rotate the complete flue terminal assembly.
- 2 Refit the terminal end (B) and secure with screws (A).
- 3 Loosen screws (C) and rotate the entire outlet assembly to redirect the plume. Re-tighten screws (C) to secure in the required position.

NOTE: The flue terminal outlet has built-in stops to limit rotation for horizontal fluing to allow condensate to run back into the boiler for safe disposal. Do not attempt to force beyond the limit stops.

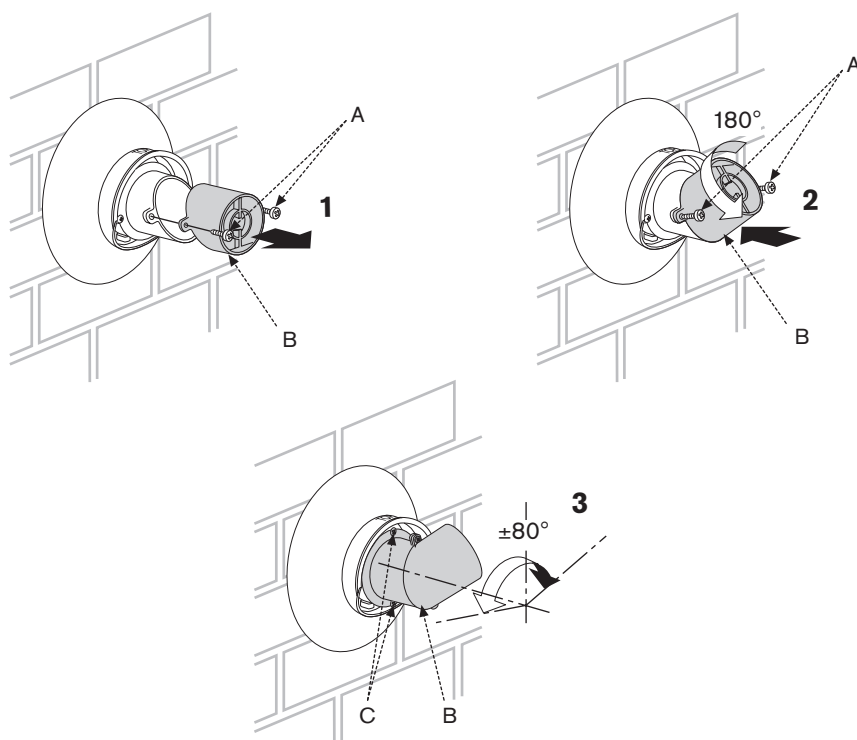

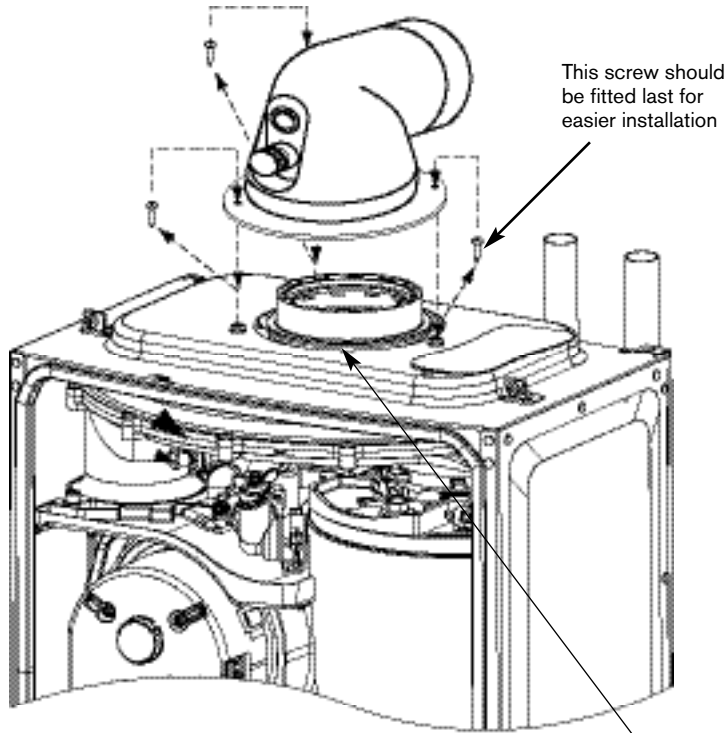

This screw should be fitted last for easier installation

Apply silicone grease to seal

- 4 Assemble elbow to boiler using the three screws (see below).

Note: Screws are in boiler not in flue kit.

FITTING THE ELBOW:

- Flue elbow should push directly down and not be twisted into correct position.
- ▶ Remove the 3 inner flue tube retaining screws. The inner tube will be held in place in the appliance.
- ▶ Fit turret onto appliance and retain with the three removed screws.

NOTE: The clamping plate flat should be at the rear of the appliance.

ADDITIONAL NOTES AND REMINDERS:

- Ensure that all cut lengths are square and free from burrs.
- The flue, when assembled, is fully sealed and components are pushed home.
- The flue is set at an angle of 3° or 52mm per 1m length.

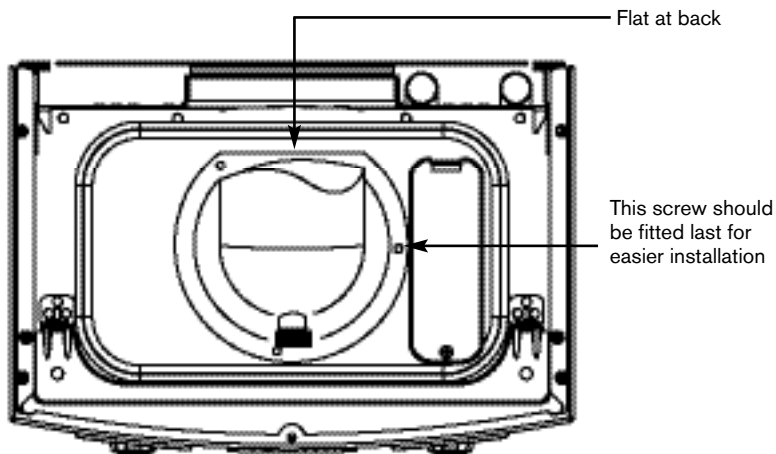

Flat at back

This screw should be fitted last for easier installation

CONDENSATE CONNECTION:

Never terminate or discharge into any open source, including; sink, bath, shower, bidet, toilet etc.

NOTE: Any external condensate pipework should be protected with weather resistant insulation to help prevent freezing.

- Ensure that the condensate drain is 22mm diameter plastic pipe. It must fall at least 50mm per metre towards the outlet

NOTE: Do not use solvents, adhesive or lubricant when pushing the pipe onto the rubber connector.

- A 22mm adaptor (A) and sealing washer (B) is supplied in the fitting pack

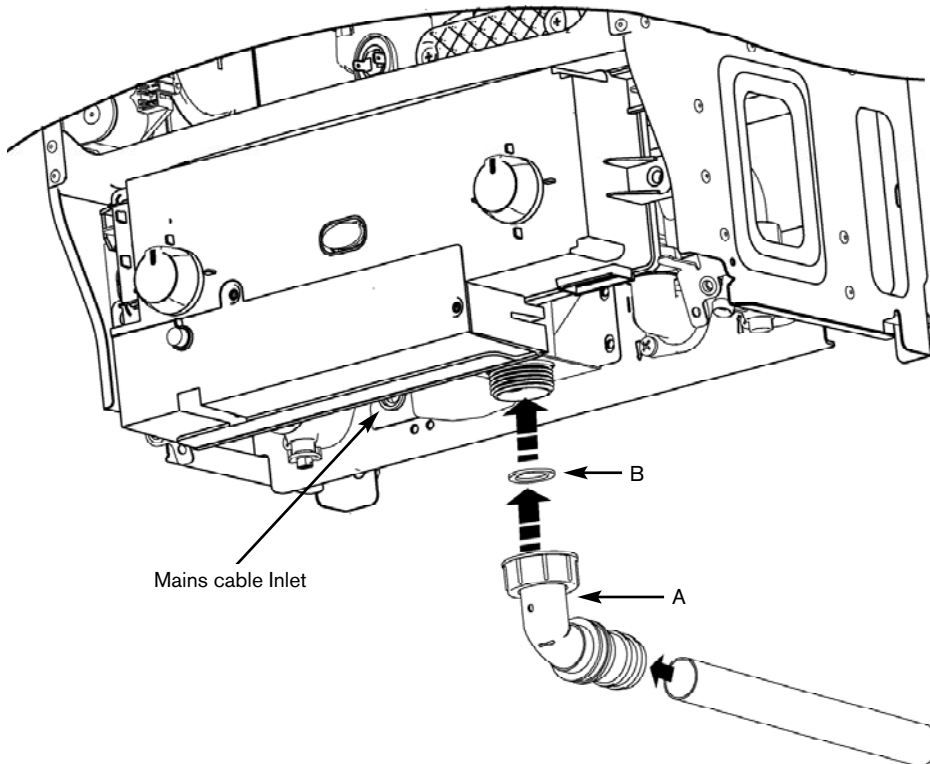

ELECTRICS

CAUTION: ISOLATE THE MAINS ELECTRICITY SUPPLY BEFORE STARTING ANY WORK AND OBSERVE ALL RELEVANT SAFETY PRECAUTIONS

The mains supply to the boiler must be either:

- from a fused double pole isolator situated next to the appliance. The isolator must have a minimum of 3mm contact separation in both poles.

or

- from a plug and non-switched socket

Use a 3A fuse in both situations.

Access to electric control panel:

- 1 Remove boiler casing to access control panel.
- 2 Unscrew the three screws (A) in the control panel and pull off the connections cover (B).
- 3 Unclip cable clamp (C).
- 4 Cut off the tapered cable entry to fit cable diameter required.
- 5 Turn cable retaining screw (D) anti-clockwise
- 6 Run cable through the fixed grommet in the main crossbar marked "mains cable" and through the cable clamp (C), ensure there is ample cable to reach the connectors.
- 7 Turn cable clamping screw (D) clockwise to secure cable and replace clamp (C) into control panel.

8 Mains power 230v connection (ST1):

- ▶ Separate wires from cable end and strip to 6mm
- ▶ Connect LIVE wire to terminal (L)
- ▶ Connect NEUTRAL wire to the terminal (N)
- ▶ Connect EARTH wire to earth bracket

9A External Pump (ST2): Max power 90 W

- ▶ Connect NEUTRAL wire to terminal (Np)
- ▶ Connect LIVE wire to terminal (Lp)
- ▶ Connect EARTH wire to earth bracket

NOTE:

THE SYSTEM PUMP MUST BE CONNECTED TO THE APPLIANCE FOR THE PUMP OVER-RUN FACILITY.

9B Boiler Demand (from external wiring centre (ST2):

- ▶ Connect SWITCHED LIVE wire to terminal (Lr).

9C System components wired into terminal strip in accordance with system manufacturers instructions.

Refit electric control panel covers:

- ▶ Refit panel (B) and secure with screws.
- ▶ Locate lugs at top edge of panel (A) and clip in at base.

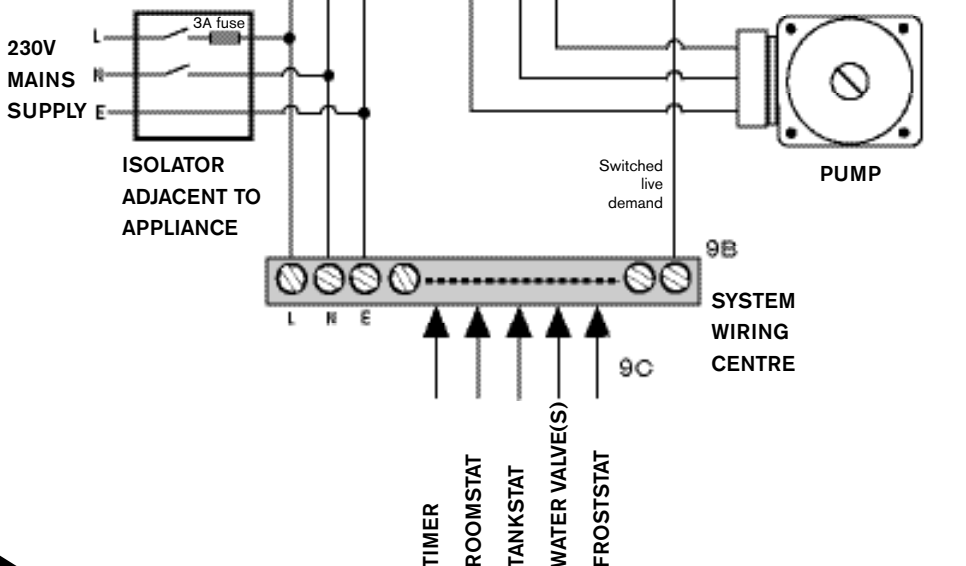

POSITION OF WIRED
COMPONENTS

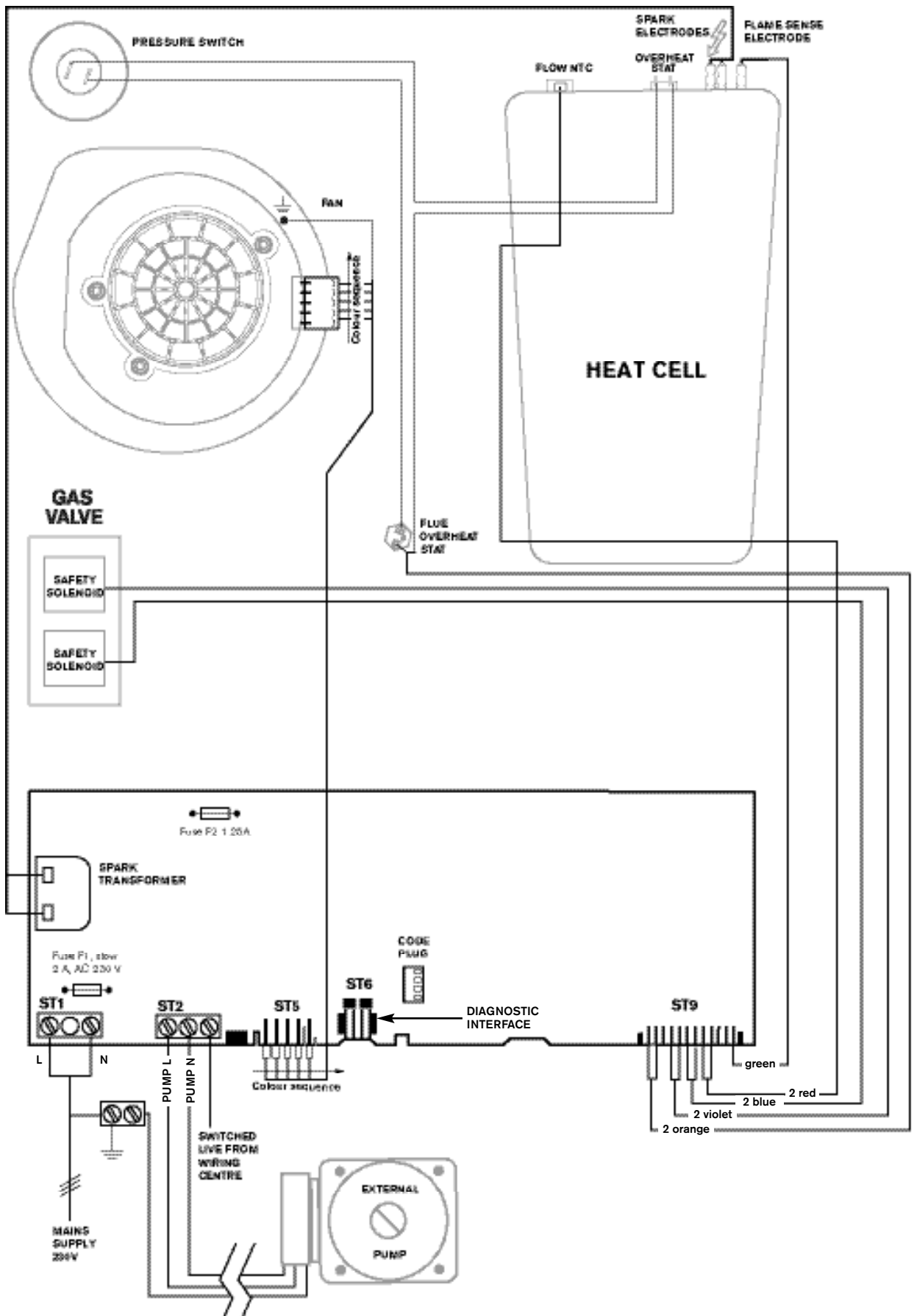

INSTALLATION

CHECKS

CAUTION: ISOLATE THE MAINS SUPPLIES BEFORE STARTING ANY WORK AND OBSERVE ALL RELEVANT SAFETY PRECAUTIONS

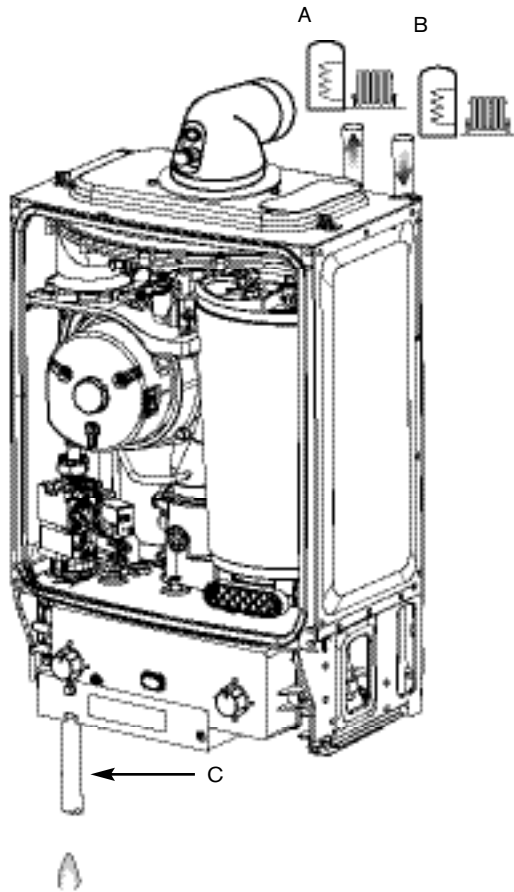

1 Check that the service and water pipes are connected to the correct position on the manifold.

A - Flow (22mm)

B - Return (22mm)

C - Gas inlet (22mm)

2 Check the gas type specified on the identification plate matches that of the gas supply. Turn on the main gas supply, check the gas pipework, connections and rectify any leaks.

NOTE: Do not use solvents, adhesive or lubricant when pushing the pipe onto the rubber connector.

3 Check that the condensate pipe (D) has been connected to the syphon.

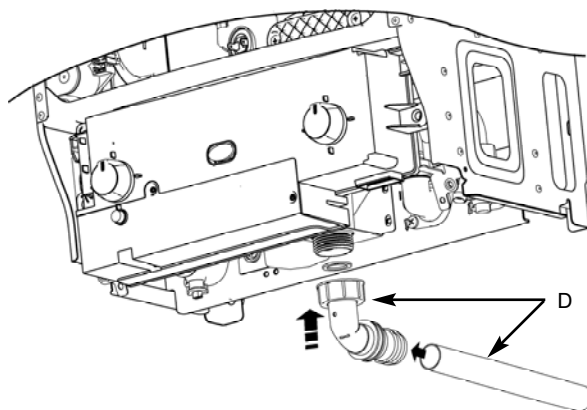

IMPORTANT: If the boiler is not to be commissioned immediately then: after successfully completing all of the checks and any rectification work, close the gas and water valves, shut off the gas supply and electrically isolate the boiler.

FILLING THE SYSTEM

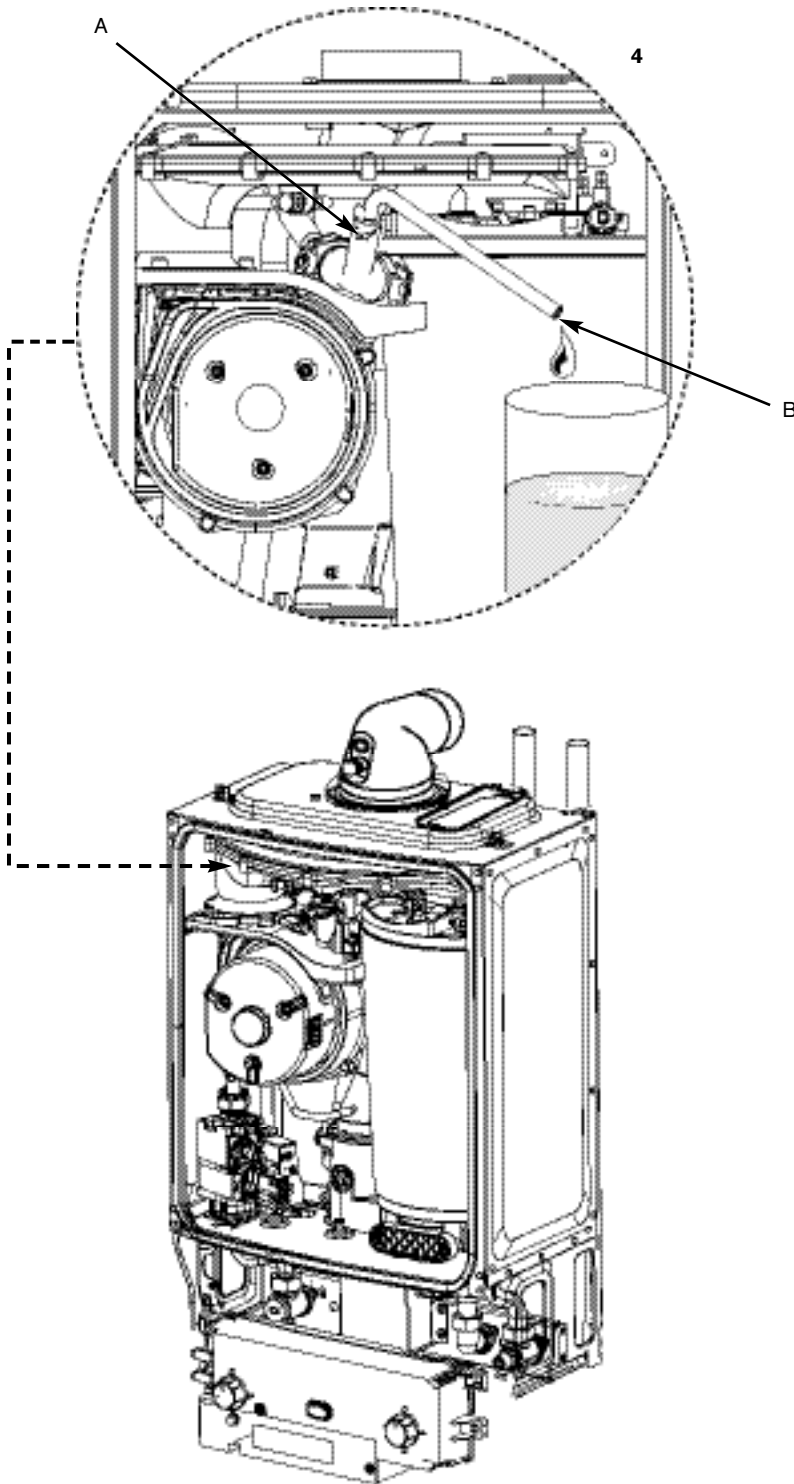

- 1 Ensure all system and boiler drain points are closed.
- 2 If connected to an open vented system turn on the water supply to system header tank and allow to fill the system.
- 3 For sealed systems fill the system using a WRAS approved filling loop to a pressure of 1 bar.
- 4 Vent (A) any air from the boiler heat exchanger using a suitable container to collect any water. Ensure tube outlet (B) is directed away from the fan or any other electrical component to prevent any water damage. Also place a suitable cover over the fan to prevent any spillage of water onto electrical connections. **Ensure the cover is removed after venting.**
- 5 Vent all radiators and primary side of the hot water cylinder.

GAS SUPPLY

- ▶ Open gas cock on the boiler and purge the gas supply to the boiler ensuring that the room is well ventilated.
- ▶ Test for gas supply for soundness as described in BS 6891.

STARTING THE APPLIANCE

IMPORTANT: Never run the appliance when the appliance/system is empty or partially filled.

Switching the appliance on/off:

- 1 ▶ Turn on mains power supply
 - ▶ Turn on any external controls
 - Set the thermostatic radiator controls to maximum temperature
 - Set the clock/programmer to continuously ON and the room thermostat to maximum temperature
- 2 ▶ Turn control (A) from 0 (off position) to I (on position), after 2 seconds the power on indicator (B) illuminates BLUE.
- 3 ▶ Turn the boiler thermostat control (C) to maximum. The burner on indicator (D) illuminates GREEN.
- 4 ▶ If the boiler fails to light and the boiler goes to flame lock-out the BLUE power indicator (B) will flash.

To reset the lockout turn the boiler thermostat control to minimum, then past minimum where the control will click at reset position, wait 5 seconds then turn to maximum. The boiler will be reset.

CAUTION: DO NOT PRESS POWER INDICATOR (B) TO RESET BOILER.

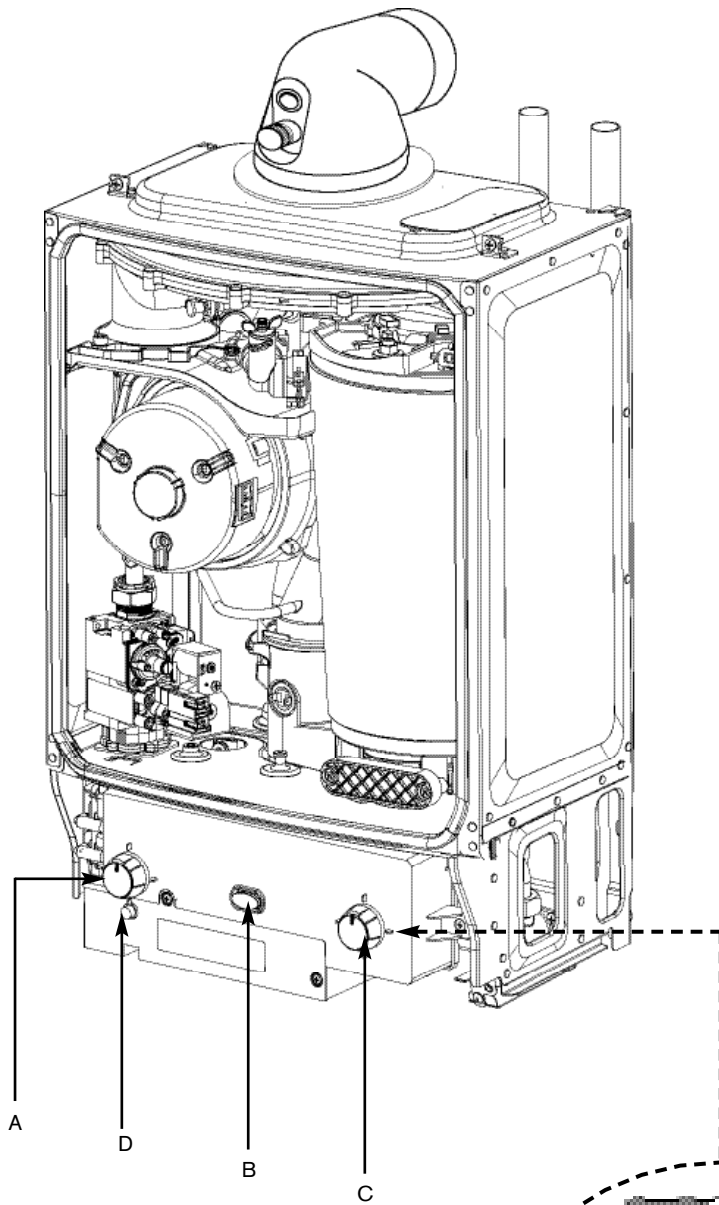

COMMISSIONING

IMPORTANT: ARTIFICIALLY SOFTENED WATER MUST NOT BE USED TO FILL THE CENTRAL HEATING SYSTEM.

IMPORTANT: Debris from the system can damage the boiler and reduce efficiency. Failure to comply with the guidelines for the use of water treatment with the appliance will invalidate the appliance warranty.

ENSURE THAT THE SYSTEM HAS BEEN CLEANED AS ON PAGE 6 OF THESE INSTRUCTIONS.

FLUSHING (Central Heating):

- ▶ Switch off the boiler. If connected to an open vented system turn OFF the water supply to the system header tank
- ▶ Open all drain cocks and drain the system while the appliance is hot.
- ▶ Close drain cocks and add a suitable flushing agent at the correct strength for the system condition in accordance with the manufacturer's instructions.
- ▶ Run the boiler/system at normal operating temperature for the time stated by the manufacturer of the flushing agent.
- ▶ Drain and thoroughly flush the system to remove the flushing agent and debris.

INHIBITOR (Central Heating):

- ▶ Check drain cocks are closed and all radiator valves are open before adding a suitable*inhibitor (or combined inhibitor/anti-freeze if the system is exposed to freezing conditions) to the heating system water in accordance with the manufacturers instructions.

*** compatible with aluminium. The pH value of the system water must be less than 8 or the appliance guarantee will be invalidated.**

- ▶ If connected to an open vent system turn on the water supply to the system header tank and allow to fill the system.
If connected to a sealed system fill via a WRAS approved filling loop to between 1 and 2 bar.
- ▶ Vent all radiators; Re-tighten vents when complete. Vent any air from the boiler heat exchanger using a suitable container to collect any water.
- ▶ **Ensure tube outlet is directed away from the fan or any other electrical component to prevent damage.**
- ▶ Vent all radiators and the primary side of the hot water tank.
- ▶ For sealed systems re-pressurise if necessary.
- ▶ Turn pressure relief valve anti-clockwise until the pressure is 1 bar.
- ▶ Set all controls to maximum.
- ▶ Record the date when the inhibitor was added to the system on the guarantee card.

NOTE: The concentration level of inhibitor in the system should be checked every 12 months or sooner if system content is lost.

The addition of sealing agents to the system water is not recommended as this can cause problems with deposits left in the heat exchanger.

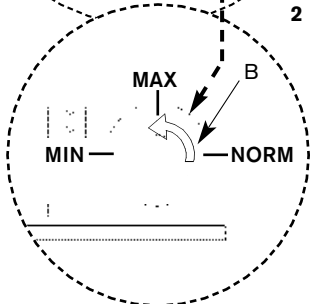
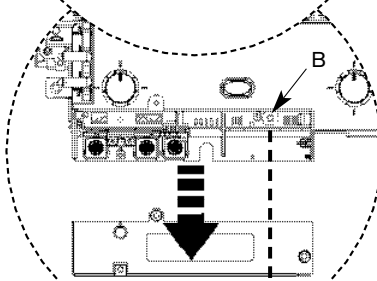
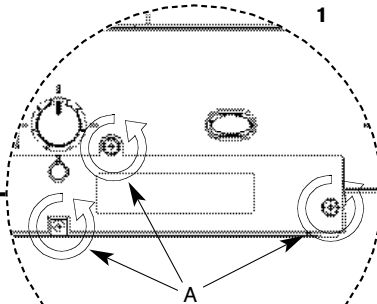
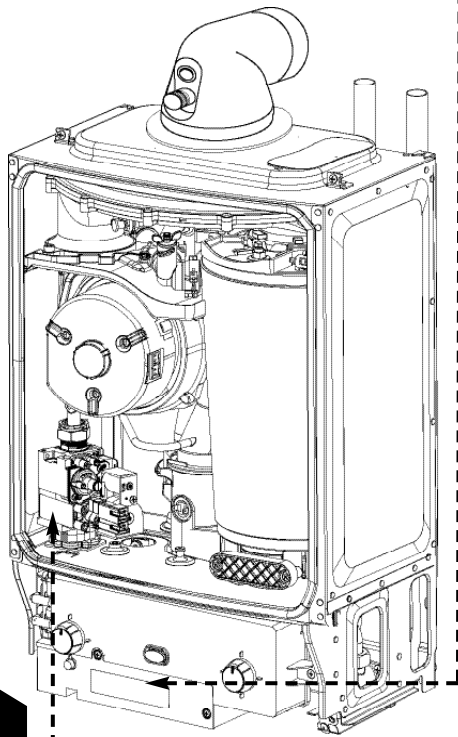

SIT VALVE

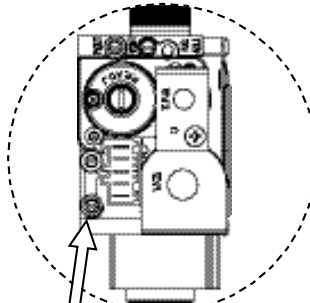

Inlet Test Nipple

DUNGS VALVE

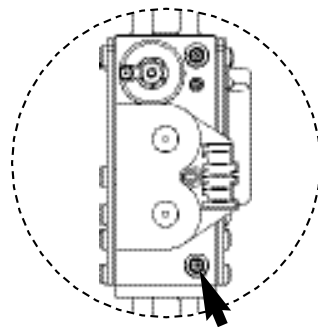

Inlet Test Nipple

THE COMBUSTION FOR THE APPLIANCE IS FACTORY SET. NO ADJUSTMENT IS REQUIRED IF THE GAS INLET PRESSURE IS CORRECT.

CHECKING GAS INLET PRESSURE:

The inlet pressure to the appliance must be checked using the following procedure:

SETTING THE BOILER TO MAXIMUM:

- 1 Remove the three screws (A) retaining the control cover.
 - Clipped inside the cover is a plastic tool used to change the position of the mode switch (B).
 - Ensure the boiler is powered up and there is a demand from the external controls.
- 2 Using the tool set the mode switch to maximum.
 - The power indicator will flash and the boiler will stay in this mode for 15 minutes if no further change is made to the switch.

MEASURING THE INLET PRESSURE:

- 3 Slacken the screw in the inlet pressure test point and connect a manometer.
 - ▶ Measure the pressure with the boiler running at maximum.
 - ▶ Check the gas supply working pressure at the gas valve inlet point is no less than:
 - N.G. 18.5 mbar
 - L.P.G. 37 mbar
 - ▶ Ensure inlet pressure is satisfactory with all other gas appliances working.

IMPORTANT: Do not continue commissioning until the correct gas pressure is achieved.

- ▶ The gas rate should be measured at the gas meter after 10 minutes operation at maximum. See technical data section at the front of this manual.
- ▶ If pressure is satisfactory turn the mode switch (B) to norm and remove the manometer.
- ▶ Re-seal the screw in the gas inlet pressure test point.
- ▶ Replace controls cover.

Note: This boiler is designed with differential of 20°C across the heating system.

1

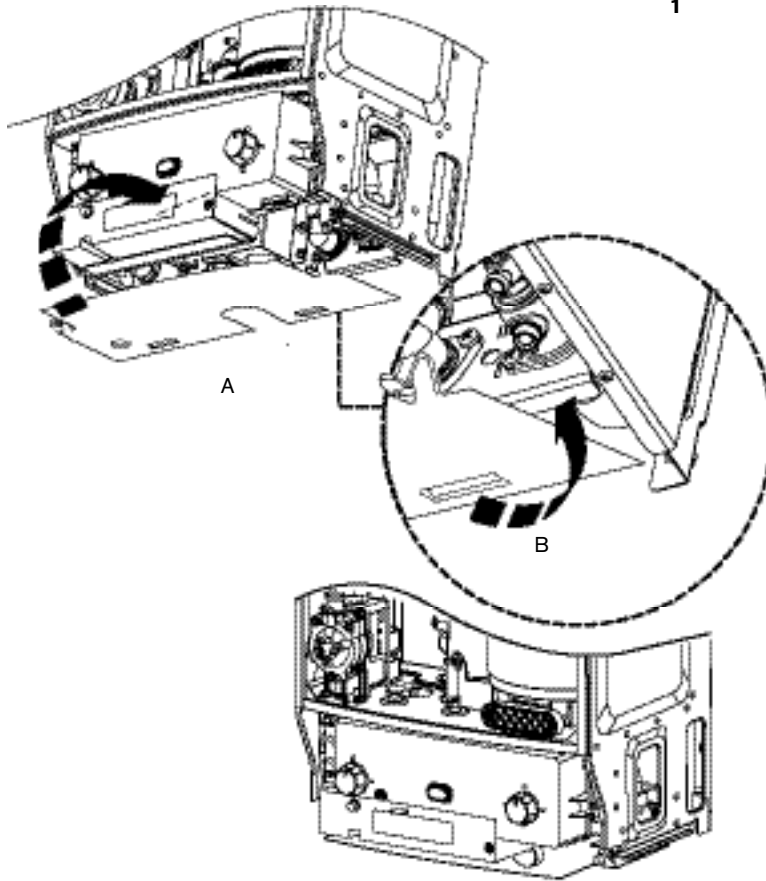

The boiler has been factory set, so there should be no need to adjust any controls.

- 1 Install bottom panel.
 - A The cut out in the bottom panel fits easily over the syphon elbow and outlet, however care should be taken not to disturb any sealed components.
 - B Hook the lip at the back of the bottom panel over the angled edge at the base of the connections manifold.
 - C Gently push up into position.
 - ▶ Clip into place over the two lugs.
- 2 Replace outer casing.
 - ▶ Replace outer casing making sure that the securing points are properly located.
 - ▶ Replace top two screws (D).
 - ▶ Re-tighten bottom two screws (E).

HANDOVER:

- ▶ Complete the Benchmark Gas Boiler Commissioning Checklist.

NOTE: The Benchmark Checklist can be found at the rear of these instructions.

- ▶ Set up the controls and show the user how to operate all the controls shown in the User Guide.
- ▶ If the appliance is unused and exposed to freezing conditions; shut off all the mains supplies and drain the system and boiler.

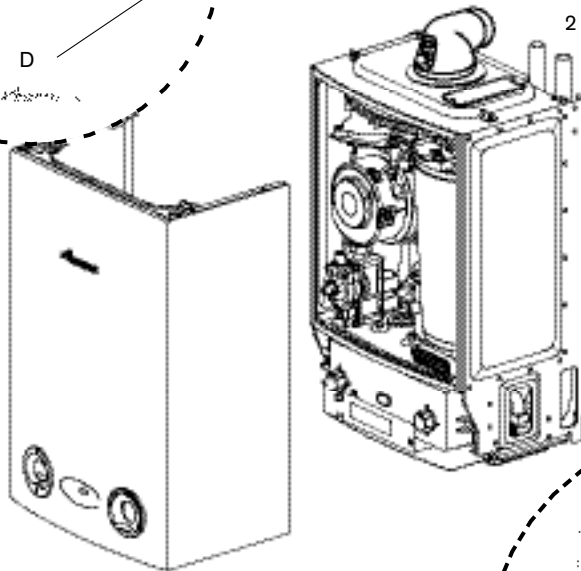
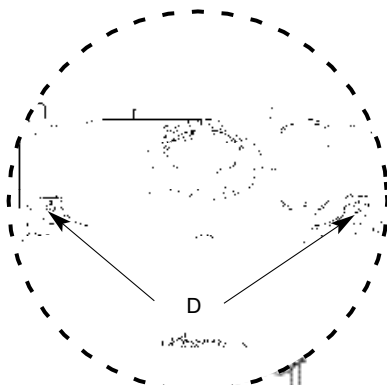

CAUTION: TURN OFF THE GAS SUPPLY AND ISOLATE THE MAINS SUPPLIES BEFORE STARTING ANY WORK AND OBSERVE ALL RELEVANT SAFETY PRECAUTIONS.

IMPORTANT: AFTER REPLACEMENT OF ANY COMPONENTS ALWAYS CHECK FOR GAS SOUNDNESS WHERE RELEVANT AND CARRY OUT FUNCTIONAL CHECKS AS DESCRIBED IN COMMISSIONING. ANY O-RING OR GASKET THAT APPEARS DAMAGED MUST BE REPLACED.

INSPECTION AND SERVICE

IMPORTANT: Any service work must be carried out by competent registered engineers such as British Gas or Corgi registered personnel.

NOTE: A service must NOT be attempted if a CO/CO₂ analyser is NOT available.

- To ensure the continued efficient operation of the appliance it must be checked at regular intervals.
- The frequency of servicing will depend upon the particular installation conditions and usage however, an annual service is recommended.
- The extent of the service required by the appliance is determined by the operating condition of the appliance when tested by **fully qualified engineers**.
- The service interval record sheet at the rear of these instructions **must** be completed after each service.

Inspection

- 1 Check that the terminal and the terminal guard, if fitted, are clear and undamaged.
- 2 If the appliance is in a compartment or cupboard check that the specified service space around the appliance is clear. Refer to page 11 for information.
- 3 Check all the joints and connections in the system and remake any that show signs of leakage. Refill and re-pressurise if applicable as described in Commissioning.
 - ▶ Operate the appliance and take note of any irregularities.Refer to Fault Finding for rectification procedures.

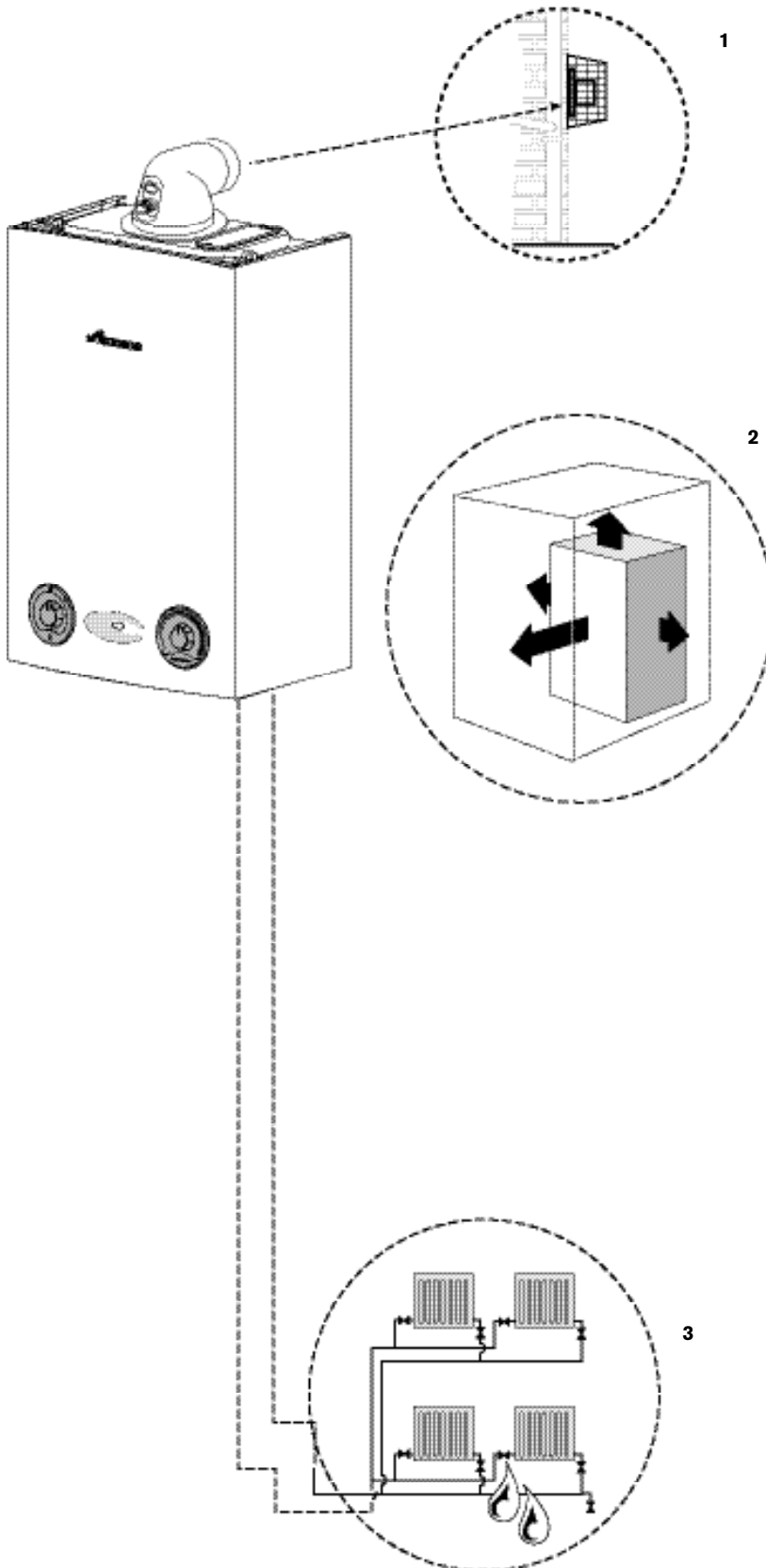

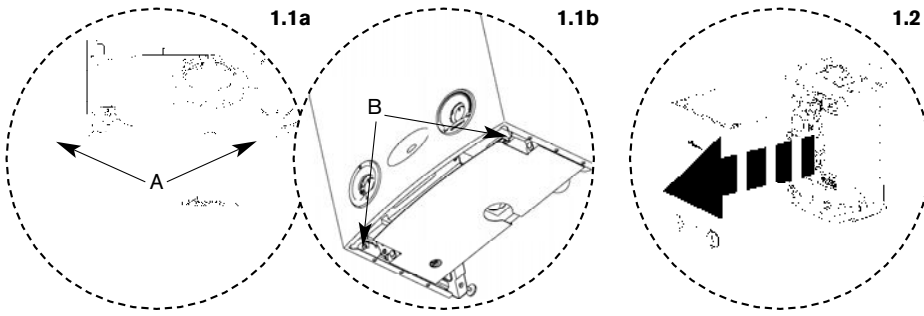

Component Access

1. Removing outer case

- 1.1a Undo and remove 2 screws (A) securing boiler casing at the top of the appliance.
- 1.1b Undo but do not remove the 2 screws (B) securing boiler casing at the bottom of the appliance.
- 1.2 Pull case forward and remove.
 - ▶ It is necessary to remove bottom tray if action 2 to 2.2 is done, this is retained by two screws at the front and hooks over the bottom frame work of the boiler.

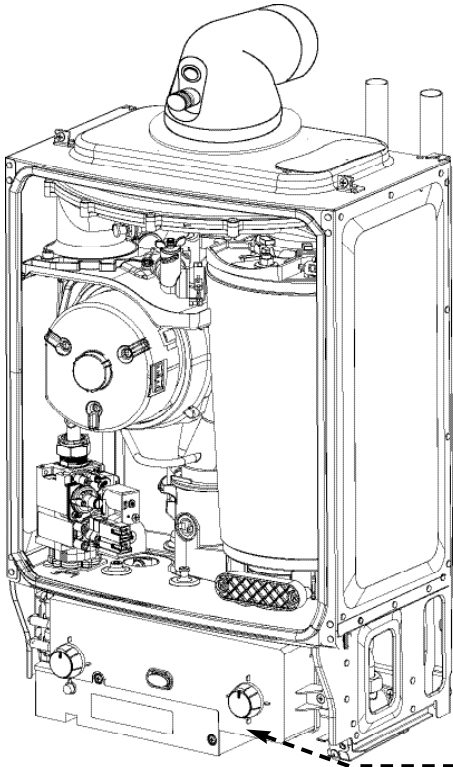

2. Adjusting boiler control to service position

- 2.1 Remove two screws (D) securing control.
- 2.2 Hang control on two lugs (E) on boiler framework.

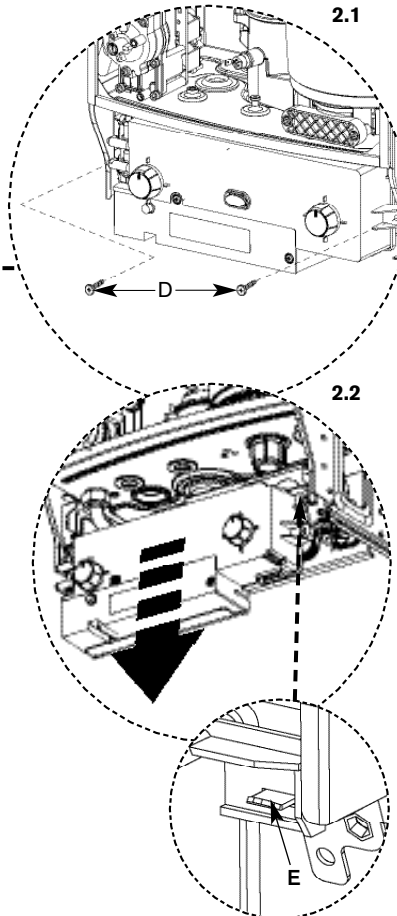

SERVICING & SPARES

Primary Heat Exchanger

There is a special accessory kit available specifically designed for cleaning the heat exchanger. If required order 7 716 192 312.

- 3 Check fan pressure at the test point next to the fan using an electronic manometer
- ▶ The boiler must be run at maximum output. Pressure will read **negative** and be greater than:

	NG	LPG
12kW	- 3.6 mbar	- 3.9 mbar
15kW	- 5.5 mbar	- 5.8 mbar
18kW	- 7.4 mbar	- 8.0 mbar
24kW	- 3.1 mbar	- 4.1 mbar

- ▶ Pressures measured below these figures will indicate that the heat exchanger will require cleaning

Setting Boiler to Maximum.

- 1 Remove the three screws (A) retaining the control cover.
 - ▶ Clipped inside the cover is a plastic tool used to change the mode switch setting (B).
- 2 Using the tool set the mode switch to maximum.
 - ▶ Ensure the boiler is powered up and there is a demand from the external controls.
 - ▶ The power indicator will flash and the boiler will stay in this mode for 15 minutes if no further change is made to the switch.
- 3 Pull cover off and connect manometer to the fan pressure test point.
 - ▶ Pressure will read negative and be greater than:
 - ▶ After measurement replace test point cover and return mode switch to normal.
 - ▶ Replace controls cover.

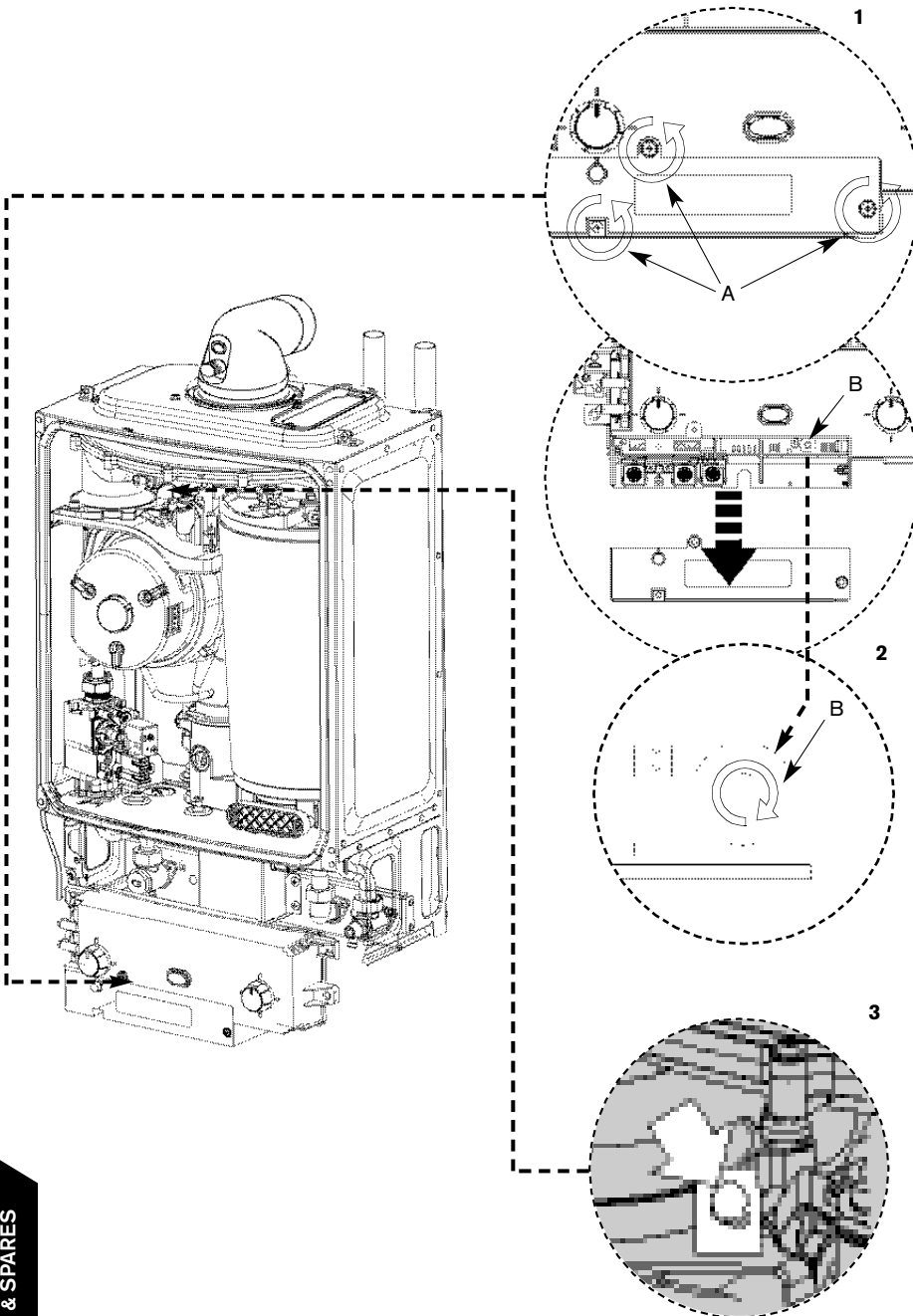

COMBUSTION TESTING MUST BE CARRIED OUT BY A COMPETENT PERSON. IT MUST **NOT** BE ATTEMPTED UNLESS THE PERSON CARRYING OUT THE COMBUSTION CHECK IS EQUIPPED WITH A COMBUSTION ANALYSER CONFORMING TO BS 7927 AND IS COMPETENT IN IT'S USE.

IMPORTANT:

▶ IF THE JOINT BETWEEN THE AIR/GAS MANIFOLD AND THE HEAT EXCHANGER IS DISTURBED THE SEALING GASKET MUST BE REPLACED.

▶ AFTER COMPLETING THE SERVICE OF THE APPLIANCE, THE CO/CO₂ MUST BE CHECKED AND SET TO THE LIMITS SHOWN IN THE "SETTING THE AIR/GAS RATIO"

To Clean the Heat Exchanger

- 1 With outer case and base panel removed and the power isolated from the appliance, remove the cover panel (A) by removing the retaining screw (B)
- 2 Remove clip (C) from gas valve outlet
 - ▶ Pull outlet elbow (E) free from the plastic connection on the gas valve
 - ▶ Pull outlet elbow (E) forward to clear case

Removing Syphon

- 3.1 Undo plastic nut (F) on the syphon outlet
Drop condensate tube away from syphon
- 3.2 Remove two screws (G)
- 3.3 Pull the syphon towards you to release from the connection and remove

Syphon

- ▶ The syphon body is opaque so that contents can be examined
- ▶ Empty the contents and flush with clean water

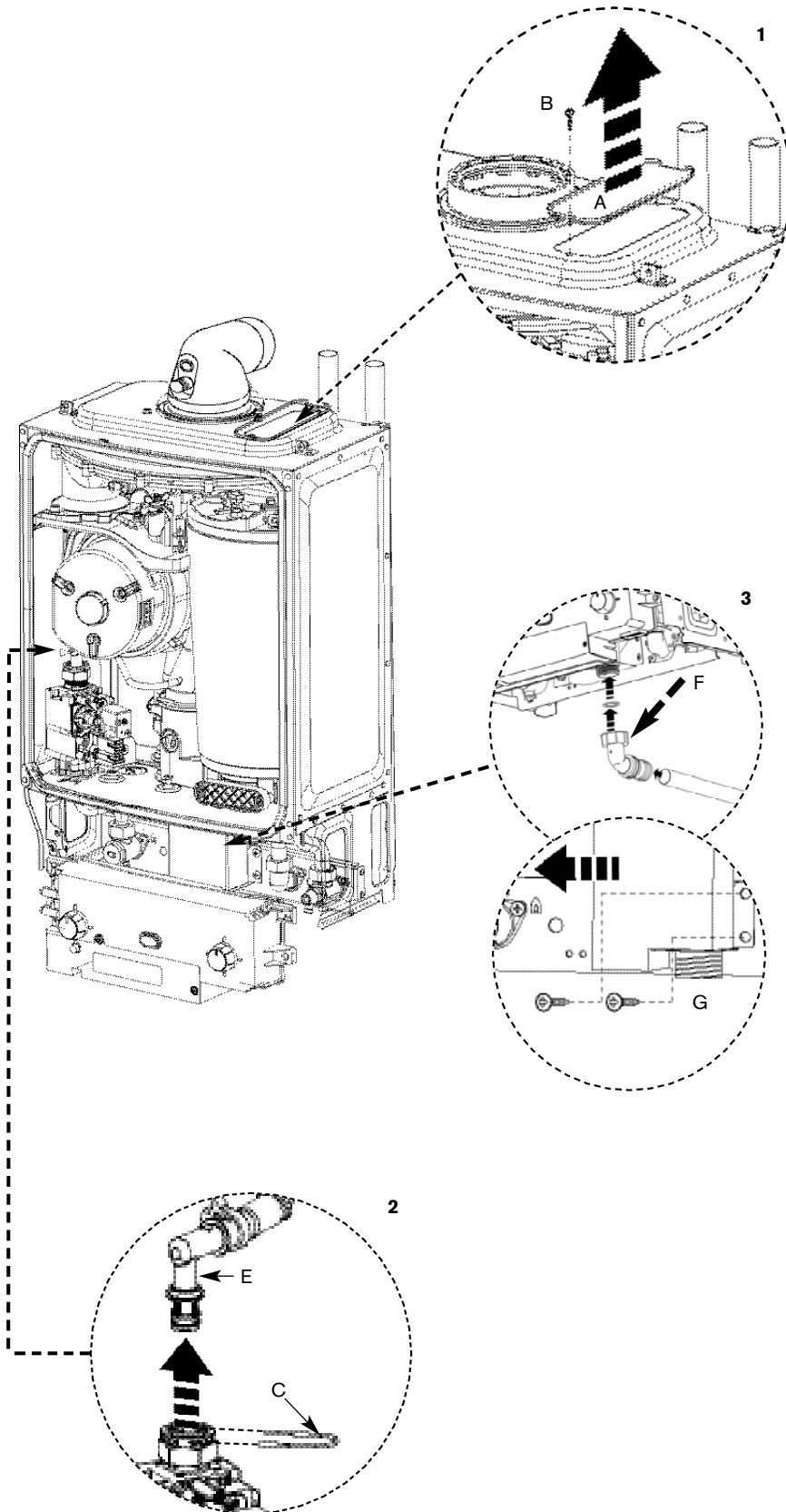

SERVICING & SPARES

INSPECTION AND SERVICE

- ▶ Remove electrical connector from fan.
- 4** Undo and remove securing nut (H) from the top of the heat exchanger.
- 5** Remove retaining plate (I).
- 6** Rotate fan and air/gas manifold assembly (J) around the top of the heat exchanger until it stops at the lug.
- ▶ Lift up assembly and remove from boiler.
- 7** Disconnect spark electrode and flame sensor connections (K).
- ▶ Remove clamping plate (L).
- ▶ Remove spark/flame electrode assembly from boiler.
- ▶ Remove seal from the top of the heat exchanger.

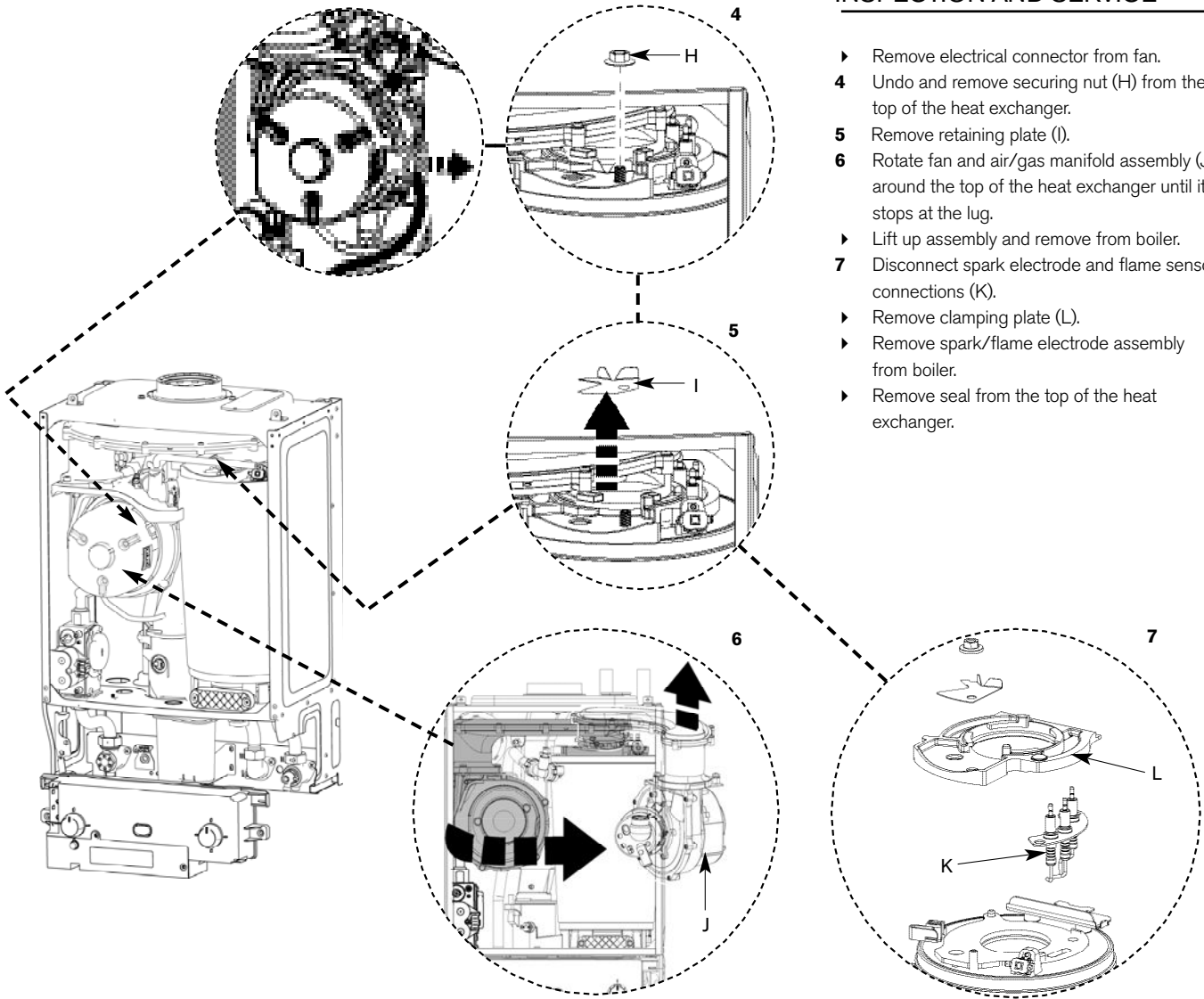

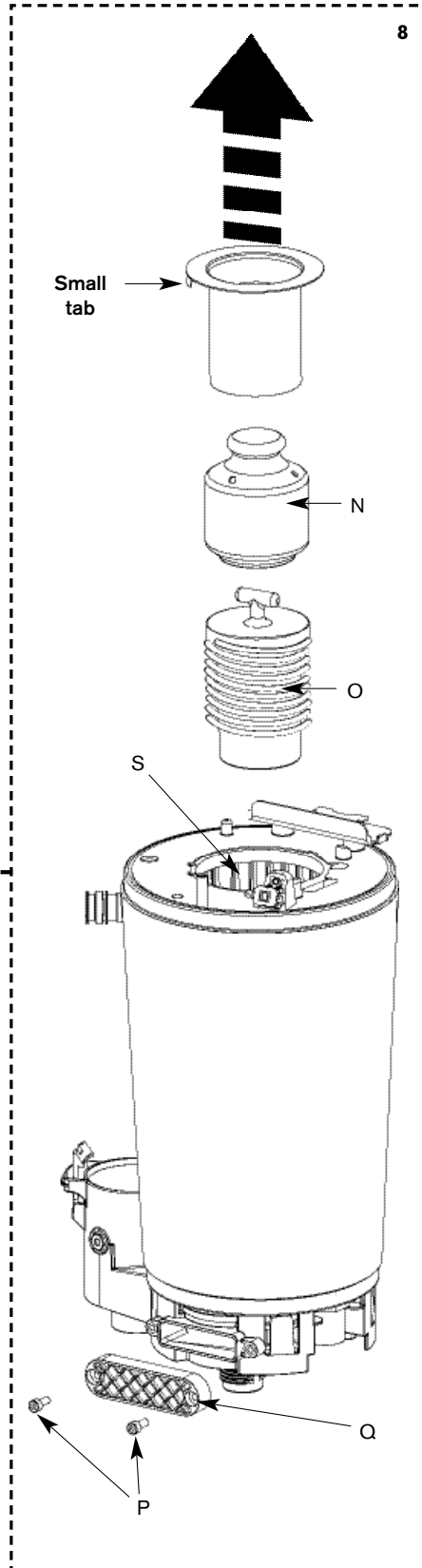
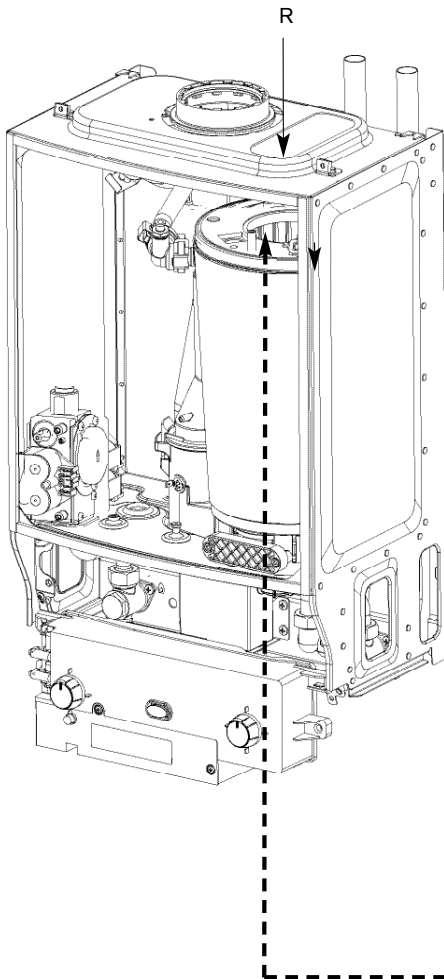

- 8**
- ▶ Remove burner (M).
 - ▶ Remove top baffle (N).
 - ▶ Remove lower baffle (O).
 - ▶ Remove the two hexagon headed screws (P) retaining the access cover (Q) on the sump.
 - ▶ Access the heat exchanger flue ways by inserting the cleaning brush (7 716 192 312) through the top access hole in the casing (R).
 - ▶ Clean heat exchanger flue ways (S) using the cleaning brush (7 716 192 312) removing any debris from the access point in the sump.

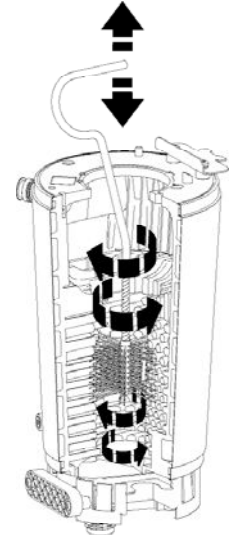

Clean around sealing surface on sump and replace access cover (Q). Using a suitable container to collect water from syphon connection at the base of the boiler flush heat exchanger with water.

- ▶ Re-assemble ensuring that the lower baffle (O) and the top baffle (N) are refitted correctly.
- ▶ When re-fitting the burner ensure that it fits centrally within the heat exchanger and location tabs are situated in location holes.
- ▶ **Ensure seal is replaced with new seal and is correctly fitted.**
- ▶ Check the syphon unit for blockage before refitting to boiler.
- ▶ **Reassemble and check combustion as stated in "Setting the air/gas ratio".**

NOTE: To show the heat exchanger more clearly it has been shown external to the appliance.

THE BAFFLES (O) AND (N) MUST BE REFITTED INTO THE HEAT EXCHANGER AS SHOWN IN 8. FAILURE TO DO SO MAY RESULT IN DAMAGE TO THE BOILER

IMPORTANT: IF THE JOINT BETWEEN THE AIR/GAS MANIFOLD AND THE HEAT EXCHANGER IS DISTURBED THE SEALING GASKET MUST BE REPLACED.

THE BOILER IS FACTORY SET. ADJUSTMENT OF AIR / GAS RATIO IS ONLY REQUIRED IF STATED IN THE SERVICING OR REPLACEMENT PARTS SECTION OF THE MAIN INSTRUCTIONS

ISOLATE MAINS ELECTRICAL SUPPLY AND REMOVE OUTER CASE AS SHOWN IN THE INSTALLATION, COMMISSIONING & SERVICING INSTRUCTIONS

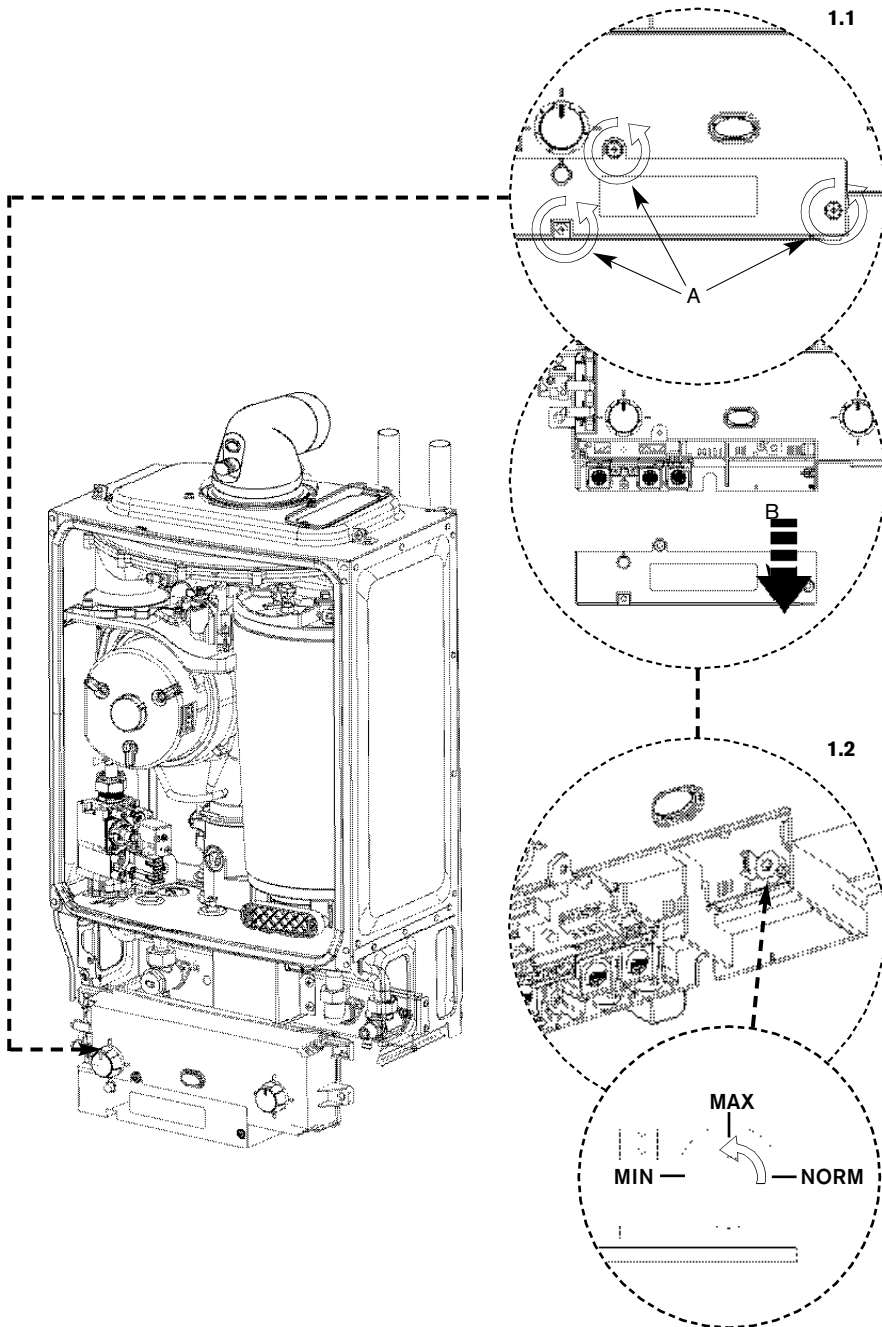

1.1 Remove 3 screws (A) and cover (B) from control box.

- ▶ Clipped inside the cover is a plastic tool used to change the mode switch setting.
- ▶ Re-connect mains electrical supply.

1.2 Using the tool set the mode switch to maximum.

- ▶ Ensure the boiler is powered up and there is a demand from the external controls.
- ▶ The power indicator will flash and the boiler will stay in this mode for 15 minutes if no further change is made to the switch.

SETTING THE AIR / GAS RATIO FOR THE SIT 848.093 SIGMA

THE SETTING OF THE GAS RATIO MUST BE CARRIED OUT BY A COMPETENT PERSON. SETTING OF THE GAS RATIO MUST **NOT** BE ATTEMPTED UNLESS THE PERSON CARRYING OUT THE CONVERSION IS EQUIPPED WITH A COMBUSTION ANALYSER CONFORMING TO BS 7927 AND IS COMPETENT IN ITS USE.

THIS PAGE SHOWS THE SETTING PROCEDURE FOR THE SIT 848.093 SIGMA VALVE. FOR ALTERNATIVE DUNGS VALVE REFER TO PAGE 40 .

1. Setting the CO/CO₂

- 1.1 Remove 3 screws (A) and cover (B) from control box.
- 1.2 Clipped inside the cover is a plastic tool, using this tool change the mode switch to maximum.
 - ▶ Ensure the boiler is powered up and there is a demand from the external controls.
 - ▶ The power indicator will flash and the boiler will stay in this mode for 15 minutes if no further change is made to the switch.
- 1.3 After running the boiler for 10 minutes connect a manometer to the inlet pressure point on the gas valve, compare the CO/CO₂ measurement with the table below.
- 1.4 Using a 2.5mm allen key set the CO/CO₂ via adjuster (C) using the table below.

CO/CO₂ settings for Greenstar Ri

NOTE. CO/CO₂ should be measured after 10 minutes

Gas type	CO ₂ setting maximum	CO ₂ setting minimum
Natural gas	9.8% ± 0.5%	9.2% ± 0.5%
LPG	11.0% ± 0.5%	10.5% ± 0.5%
CO - less than 200ppm (0.002 ratio)		

- ▶ Check CO is less than 200ppm.
 - ▶ Measure the inlet pressure; it should be no less than 18.5mb for NG or 37mb for LPG.
- 1.5 Set the mode switch to minimum.
 - 1.6 Measure the CO/CO₂ and check against the table

above. If required adjust (D) on the gas valve until the correct measurement is set. Remove brass dust cap with flat bladed screwdriver. Then using a 4mm allen key adjust CO/CO₂. Replace dust cap.

- ▶ Check CO is less than 200ppm.
- ▶ Return to maximum and re-check the CO / CO₂. If correct set the mode switch to normal and isolate mains supply.
- ▶ Remove manometer and re-seal inlet pressure point on gas valve.
- ▶ Re-assemble and refit boiler case.

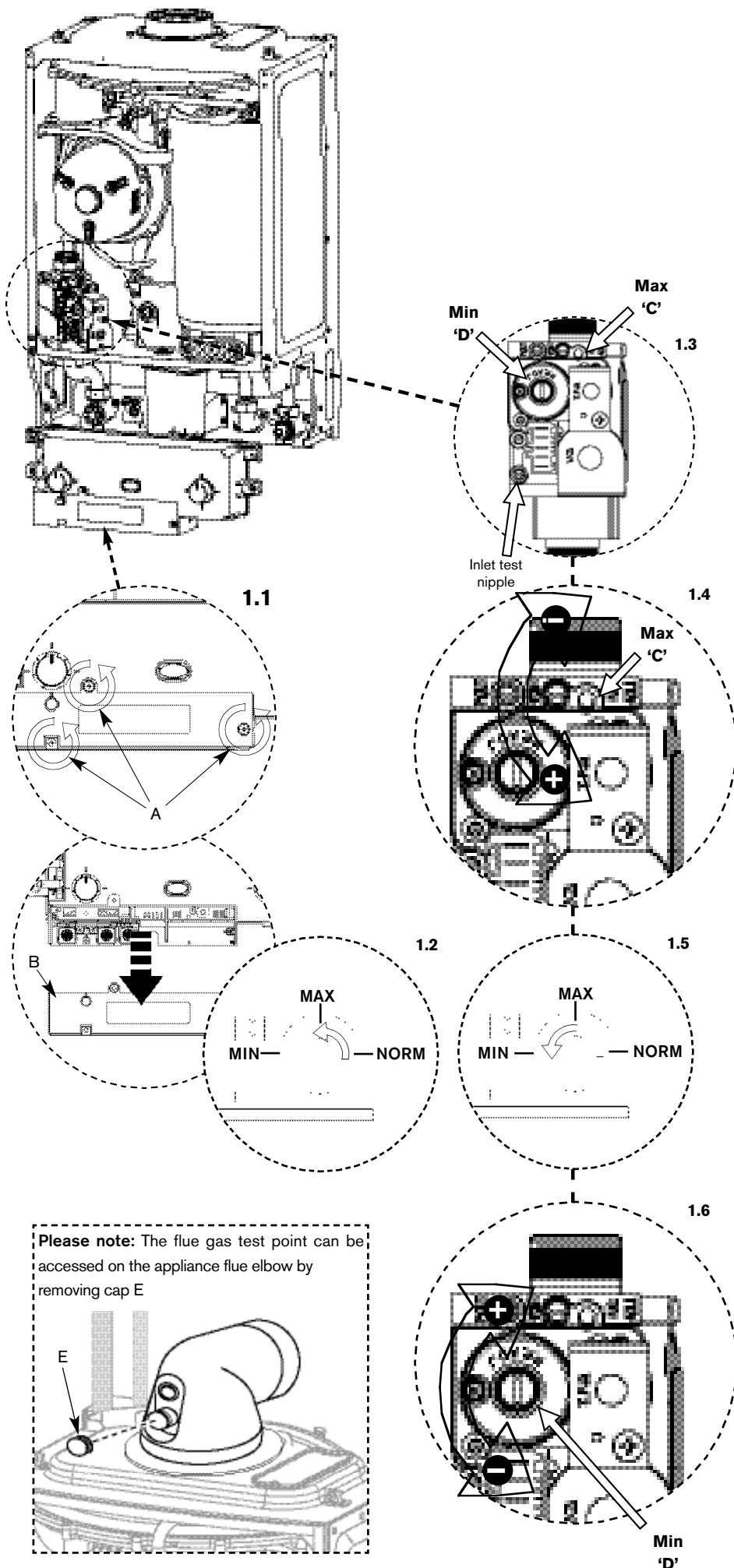

SETTING THE AIR / GAS RATIO FOR THE DUNGS GB-ND 055 D01 S20

THE SETTING OF THE GAS RATIO MUST BE CARRIED OUT BY A COMPETENT PERSON. SETTING OF THE GAS RATIO MUST **NOT** BE ATTEMPTED UNLESS THE PERSON CARRYING OUT THE CONVERSION IS EQUIPPED WITH A COMBUSTION ANALYSER CONFORMING TO BS 7927 AND IS COMPETENT IN ITS USE.

THIS PAGE SHOWS THE SETTING PROCEDURE FOR THE DUNGS GB-ND 055 D01 S20 VALVE.
FOR ALTERNATIVE SIT VALVE REFER TO PAGE 39 .

1. Setting the CO/CO₂

- 1.1 Remove 3 screws (A) and cover (B) from control box.
- 1.2 Clipped inside the cover is a plastic tool, using this tool change the mode switch to maximum.
 - ▶ Ensure the boiler is powered up and there is a demand from external controls.
 - ▶ The power indicator will flash and the boiler will stay in this mode for 15 minutes if no further change is made to the switch.
- 1.3 After running the boiler for 10 minutes connect a manometer to the inlet pressure point on the gas valve, compare the CO/CO₂ measurement with the table below.
- 1.4 Using a 2mm hexagonal ball driver set the CO/CO₂ via adjuster (C) using the table below.

CO/CO₂ settings for Greenstar Ri

NOTE. CO/CO₂ should be measured after 10 minutes

Gas type	CO ₂ setting maximum	CO ₂ setting minimum
Natural gas	9.8% ± 0.5%	9.2% ± 0.5%
LPG	11.0% ± 0.5%	10.5% ± 0.5%
CO - less than 200ppm (0.002 ratio)		

- ▶ Check CO is less than 200ppm.
 - ▶ Measure the inlet pressure; it should be no less than 18.5mb for NG or 37mb for LPG.
- 1.5 Set the mode switch to minimum.
 - 1.6 Measure the CO/CO₂ and check against the table above. If required adjust (D) on the gas valve until the correct measurement is set. Using a 2mm hexagonal ball driver adjust the CO/CO₂.
 - ▶ Check CO is less than 200ppm.
 - ▶ Return to maximum and re-check the CO/CO₂. If correct set the mode switch to normal and isolate mains supply.
 - ▶ Remove manometer and re-seal inlet pressure point on gas valve.
 - ▶ Re-assemble and refit boiler case.

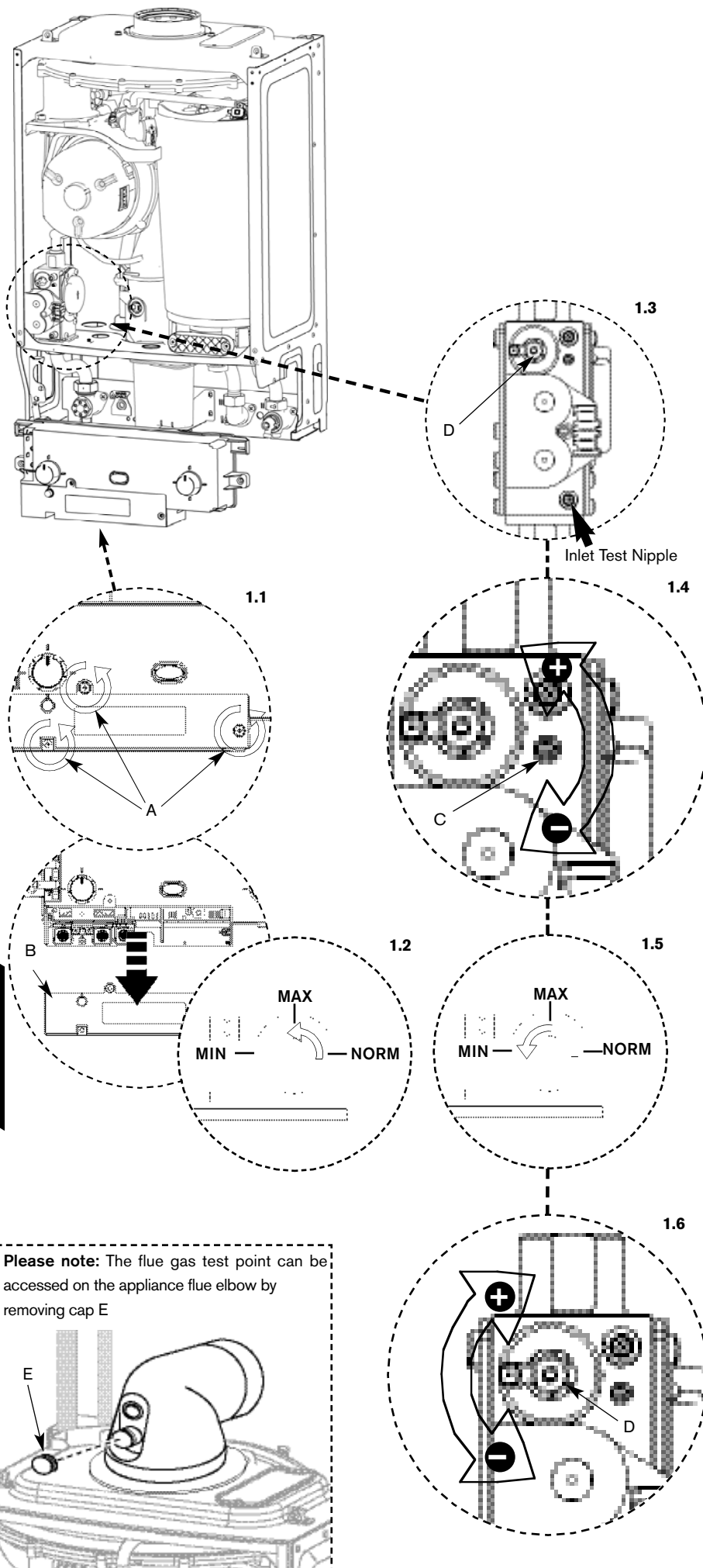

Please note: The flue gas test point can be accessed on the appliance flue elbow by removing cap E

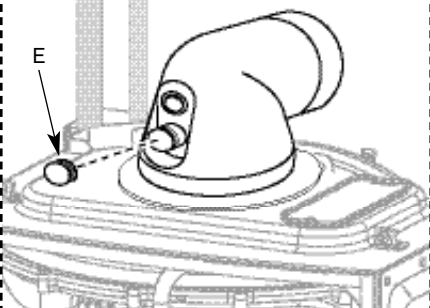

CAUTION: TURN OFF THE GAS SUPPLY AND ISOLATE THE MAINS SUPPLIES BEFORE STARTING ANY WORK AND OBSERVE ALL RELEVANT SAFETY PRECAUTIONS.

IMPORTANT: AFTER REPLACEMENT OF ANY COMPONENTS ALWAYS CHECK FOR GAS SOUNDNESS WHERE RELEVANT AND CARRY OUT FUNCTIONAL CHECKS AS DESCRIBED IN COMMISSIONING. ANY O-RING OR GASKET THAT APPEARS DAMAGED MUST BE REPLACED.

REPLACEMENT OF PARTS

1. Removing outer case

- 1.1 Undo 4 screws (A) securing boiler casing.
- 1.2 Pull case forward and remove.
 - ▶ If it is necessary to remove bottom tray, this is retained by two screws (B) at the front and hooks over the bottom frame work of the boiler.

The following components can be replaced with the outer case removed:
Primary sensor
Overheat thermostat
Flue limit thermostat

2. Primary sensor

- ▶ Remove electrical connection (C) by pulling upwards. Squeeze retaining clip on plastic moulding (D) and pull sensor (E) upwards until clear of pocket in heat exchanger.
- ▶ Coat new sensor with heat conductive paste and replace.

3. Overheat thermostat

- ▶ Remove two electrical connectors from thermostat.
- ▶ Slacken and remove fixing screw and thermostat.
- ▶ When replacing ensure thermostat sits correctly on surface of the casing with the left hand side of thermostat sitting up against the shoulder (F).

Note:

It is essential that the mating surface of the thermostat is coated with heat conductive paste.

4. Flue limit thermostat

4.1 Type B (with grommet)

- ▶ Remove electrical connections.
- ▶ Undo the flue connection from the sump and push the flue tube up.
- ▶ Push the flue limit thermostat outwards from the sump.

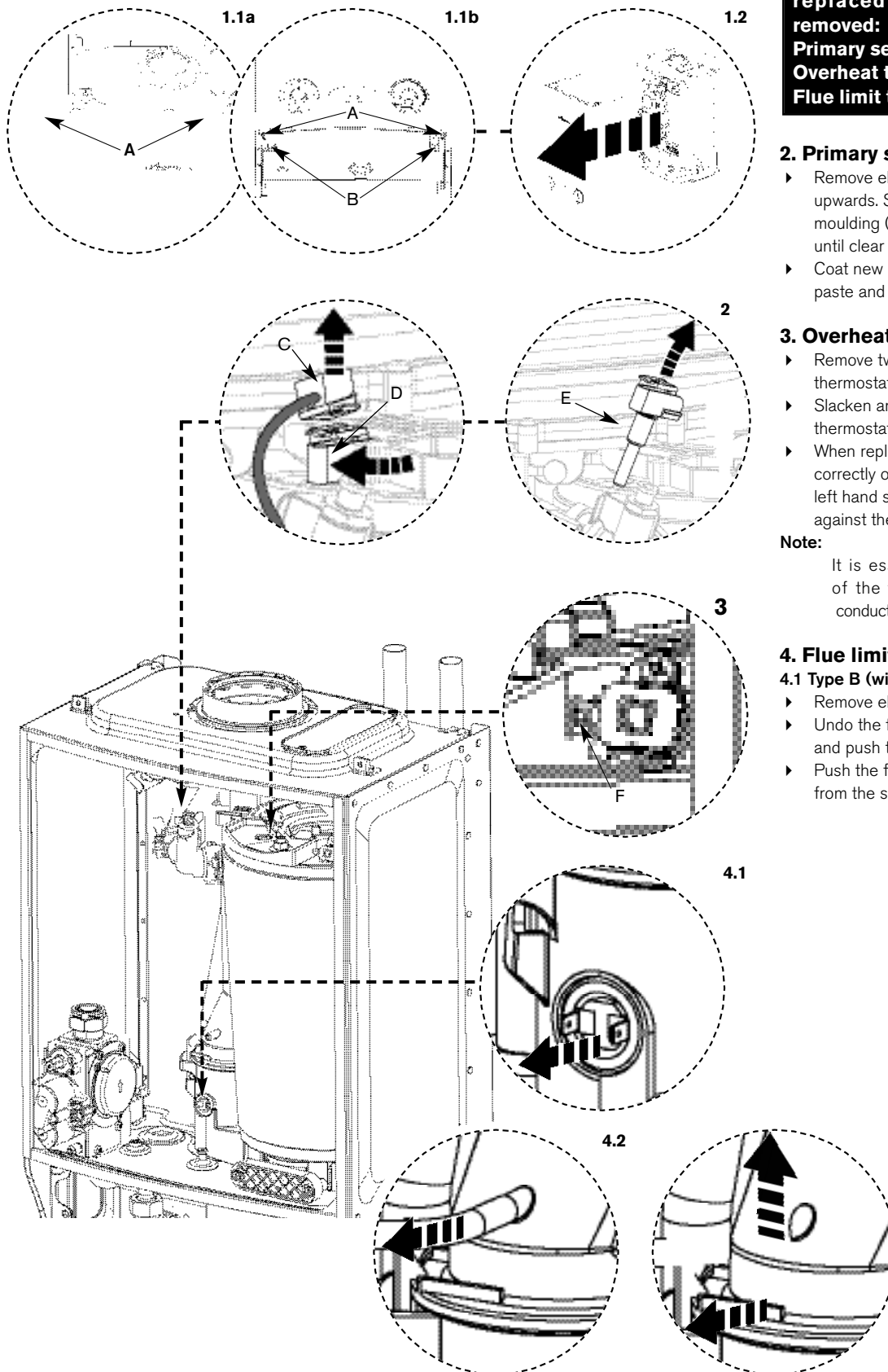

SERVICING
& SPARES

REPLACEMENT OF PARTS SIT AND DUNGS VALVE

The following components require the control to be moved in to the service position and the bottom tray removed:
Gas valve
Syphon
PCB fuse
Transformer

REMOVAL OF THE VALVE IS THE SAME FOR BOTH SIT AND DUNGS VALVES. THE SIT VALVE IS SHOWN IN THE DIAGRAM.

IMPORTANT:

Do not replace the gas valve if a CO/CO₂ analyser is NOT available.

5. Moving boiler control to service position

- 5.1** Remove two screws (A) securing control.
5.2 Hang control on two lugs (B) on boiler framework.

6. Gas valve

- ▶ Isolate both the electrical supply and the gas supply at boiler gas cock.
- 6.1** Remove wire clip from gas valve outlet then pull valve outlet elbow free from the gas valve.
6.2 Undo bottom gas connection to gas valve.
6.3 Undo two securing screws (C) on the underside of casing.
- ▶ Pull valve up and forward out of boiler.
 - ▶ Disconnect electrical connections.
 - ▶ Replace valve with new seals and check for gas soundness.

Note: The valve will require setting, follow procedure "Setting the air/gas ratio".

7. Syphon

- 7.1** Undo plastic nut (D) on the syphon outlet. Drop condensate tube away from syphon.
7.2 Remove two screws (E) retaining the bracket.
7.3 Pull the syphon towards you to release from the connection and remove.

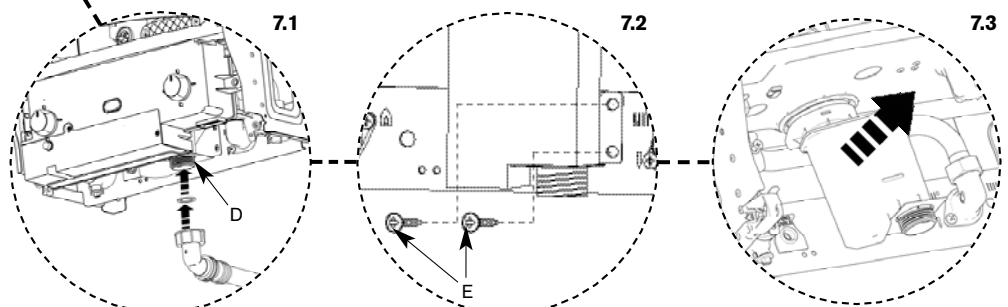
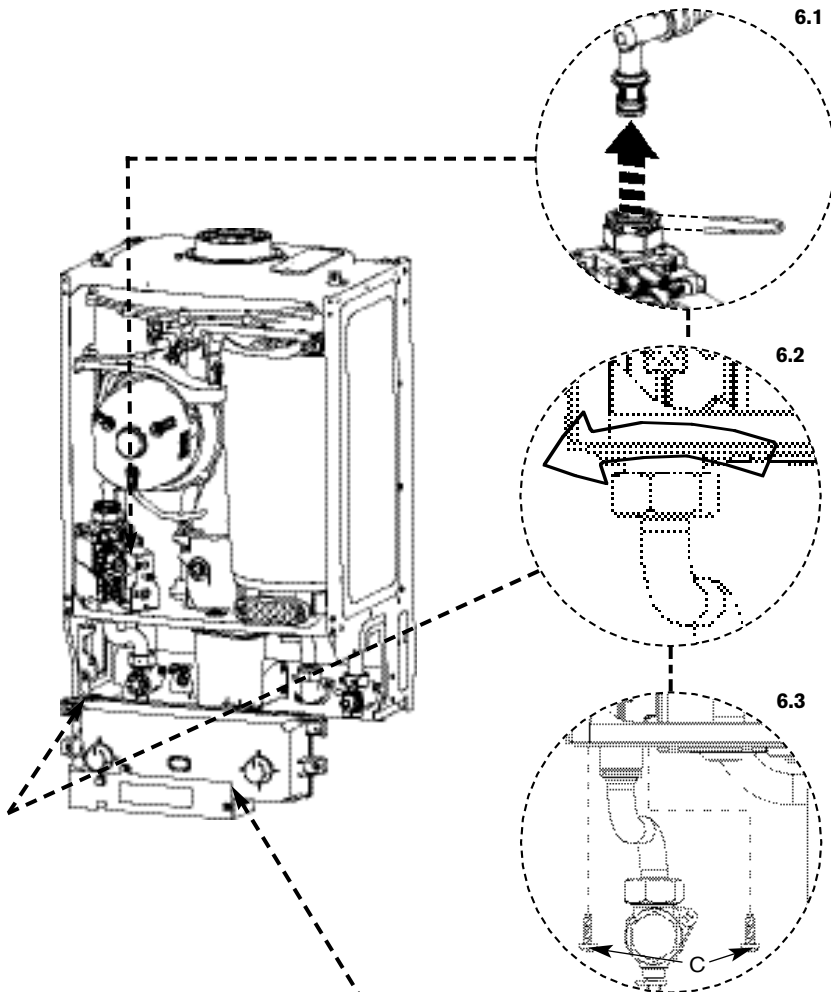
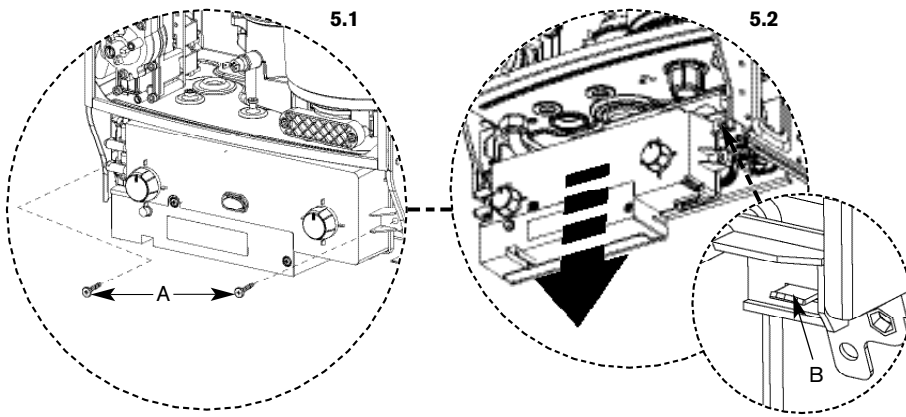

IMPORTANT:

Do not replace the control unit if a CO/CO₂ analyser is NOT available.

8. Access to boiler control components

- ▶ Move control to the service position.
- ▶ Remove 3 screws (A) and remove cover from control.
- ▶

9. PCB fuse

- ▶ Remove fuse in plastic housing (B) from the PCB and replace.
- ▶ There is a spare 2A fuse for F1 clipped into the cover.

10. Transformer / PCB

- ▶ Disconnect all electrical connections from the control.
- ▶ Remove 4 screws (C) retaining the rear panel of the control and remove panel.

IMPORTANT: ENSURE CODE PLUG IS RE-FITTED TO THE NEW CONTROL. IF THIS IS NOT DONE THE APPLIANCE WILL INDICATE ERROR AND WILL NOT FUNCTION.

NOTE:

After re-assembly, check CO/CO₂ levels as described in the setting of the air/gas ratio section.

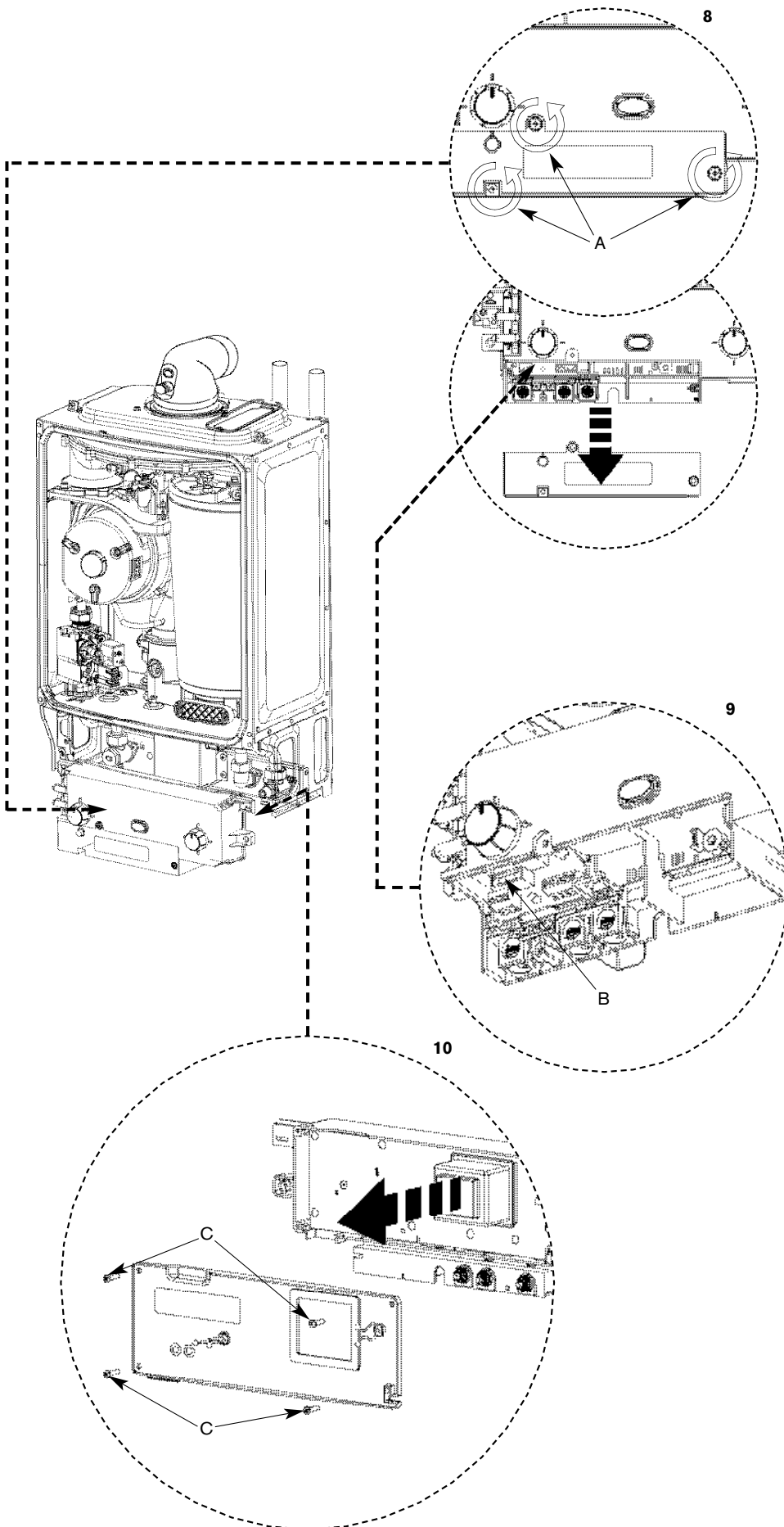

SERVICING & SPARES

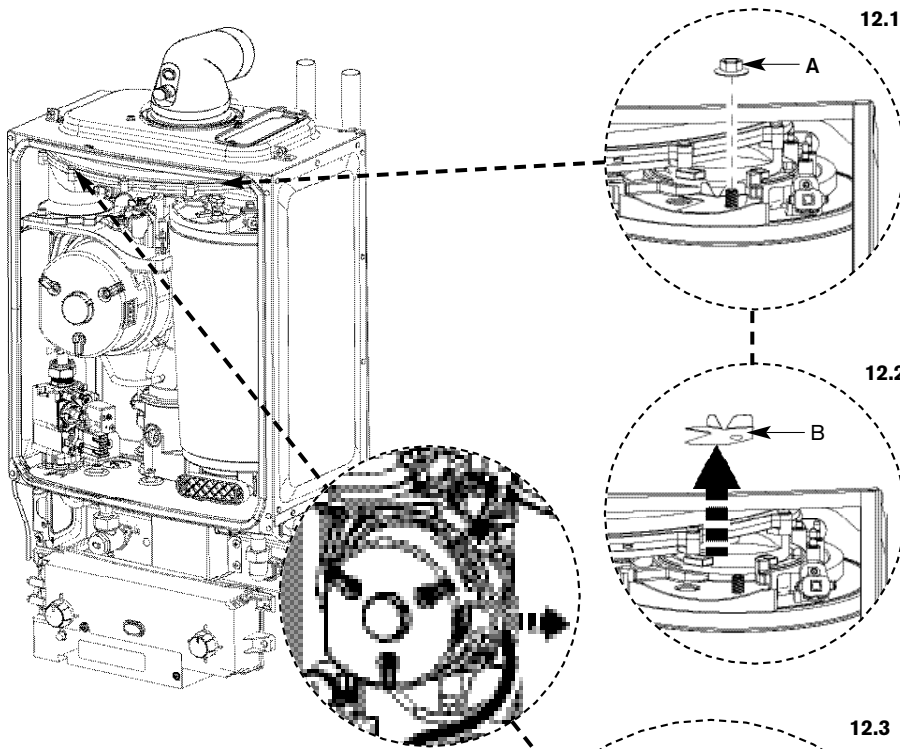

12.1

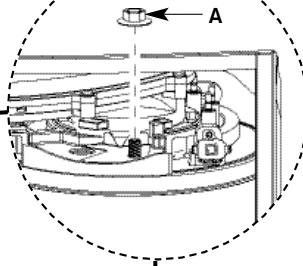

12.2

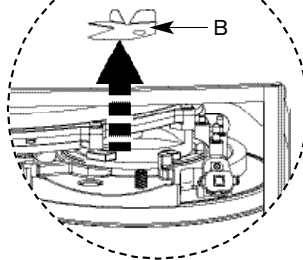

12.3

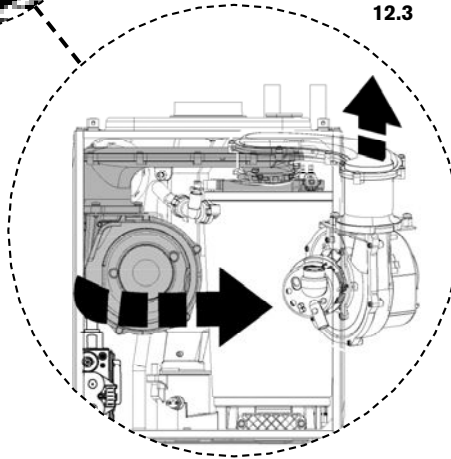

The following components require the air / gas manifold and fan assembly to be removed:
Pressure switch
Fan
Electrode assembly
Burner
Heat exchanger

IMPORTANT: IF THE JOINT BETWEEN THE AIR/GAS MANIFOLD AND THE HEAT EXCHANGER IS DISTURBED THE SEALING GASKET MUST BE REPLACED.

IMPORTANT: AFTER RE-ASSEMBLY THE COMBUSTION MUST BE CHECKED USING THE PROCEDURE IN THE SECTION "SETTING THE AIR/GAS RATIO". MEASUREMENT AND SETTING OF THE GAS RATIO MUST NOT BE ATTEMPTED UNLESS THE PERSON IS EQUIPPED WITH A COMBUSTION ANALYSER CONFORMING TO BS 7927 AND IS COMPETENT IN ITS USE.

12. Air / gas manifold and fan assembly

- ▶ Isolate the gas and electrical supplies.
- ▶ Remove electrical connector from fan.
- ▶ Remove wire clip from gas valve outlet then pull gas adjustment assembly free from plastic connector and pull clear of case. See 6.1.

12.1 Undo and remove securing nut (A) from the top of the heat exchanger.

12.2 *Remove retaining plate (B).

12.3 Rotate fan and air/gas manifold assembly (shaded) around the top of the heat exchanger until the lug on the air/gas manifold is visible.

- ▶ Lift up assembly and remove from boiler.

NOTE:

After re-assembly, check CO/CO₂ levels as described in the setting of the air/gas ratio section.

IMPORTANT: ENSURE TUBE IS REFITTED TO PRESSURE SWITCH

13. Pressure switch

13.1 Remove electrical connections (C).

13.2 Slacken top retaining screw and remove bottom screw. (D).

13.3 Remove tube (E).

13.4 Remove 2 screws (F) retaining pressure switch to bracket.

- ▶ Refit new pressure switch to bracket.

NOTE:

After re-assembly, check CO/CO₂ levels as described in the setting of the air/gas ratio section.

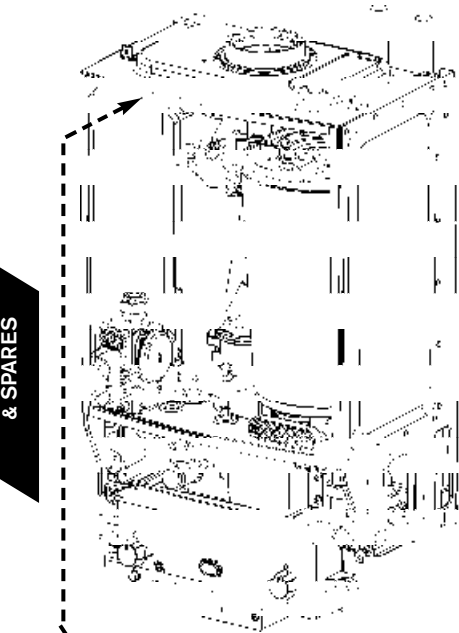

13.1

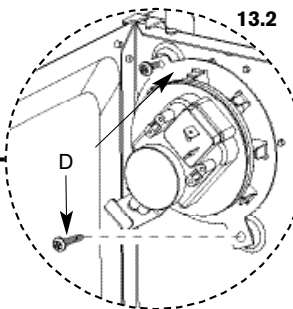
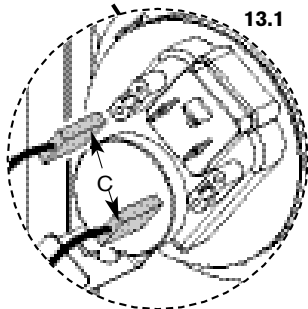

13.2

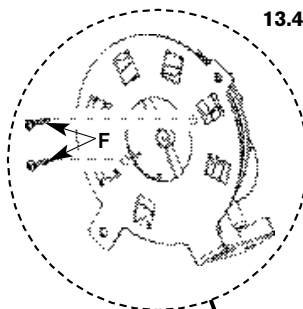

13.3

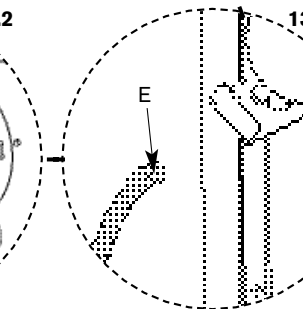

13.4

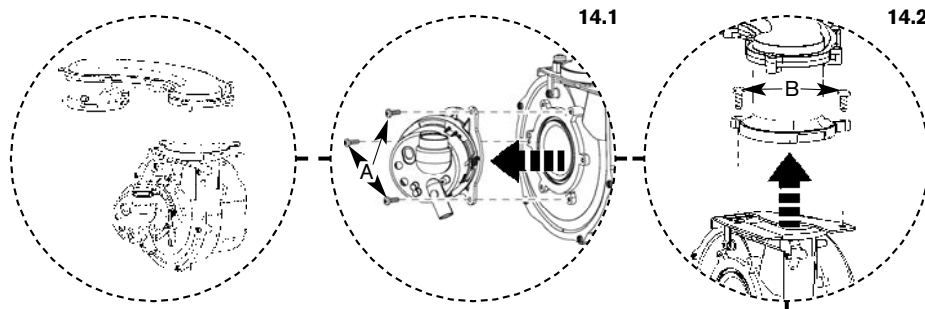

14. Fan

- 14.1 Remove 3 screws (A) retaining mixing chamber.
- 14.2 Remove 2 screws (B) retaining the fan to the air/gas manifold.
- 14.3 Remove screw (C) retaining plate and remove.
- ▶ Re-assemble with new fan ensuring seals are correctly fitted.

NOTE:

After re-assembly, check CO/CO₂ levels as described in the setting of the air/gas ratio section.

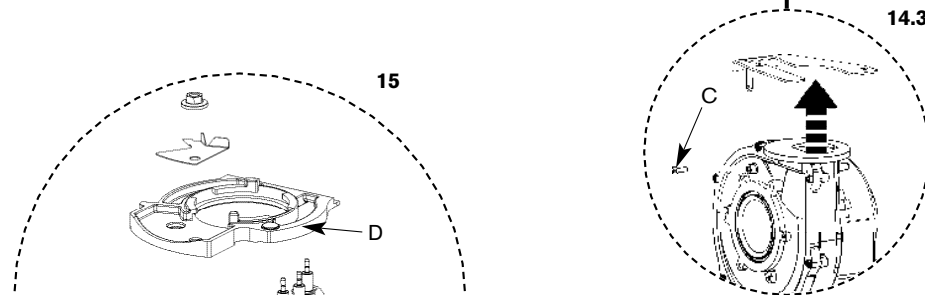

15. Electrode assembly

- ▶ Disconnect spark electrodes and flame sensor connection.
- ▶ Remove clamping plate (D).
- ▶ Remove spark/flame electrode assembly (E) from heat exchanger.

NOTE:

After re-assembly, check CO/CO₂ levels as described in the setting of the air/gas ratio section.

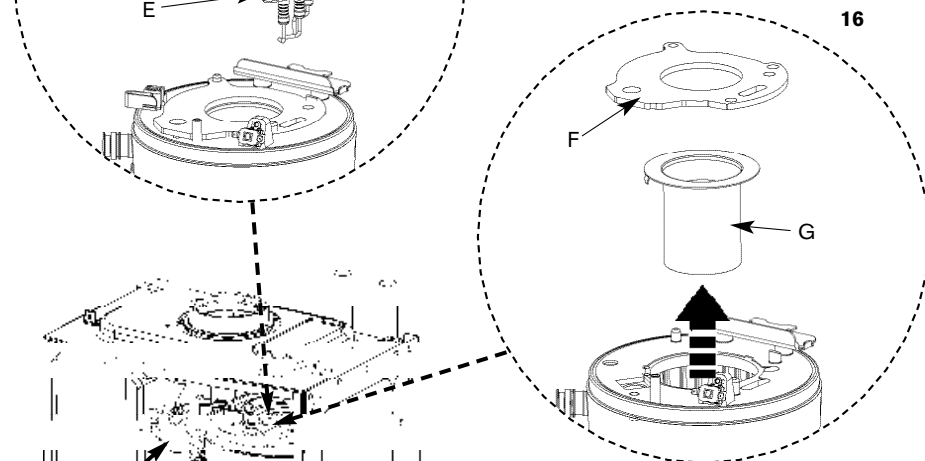

16. Burner

- ▶ Remove seal (F) from the top of the heat exchanger.
- ▶ Remove burner (G).
- ▶ Replace new burner in correct position.
- ▶ Ensure that burner tab fits correctly into hole.

NOTE:

After re-assembly, check CO/CO₂ levels as described in the setting of the air/gas ratio section.

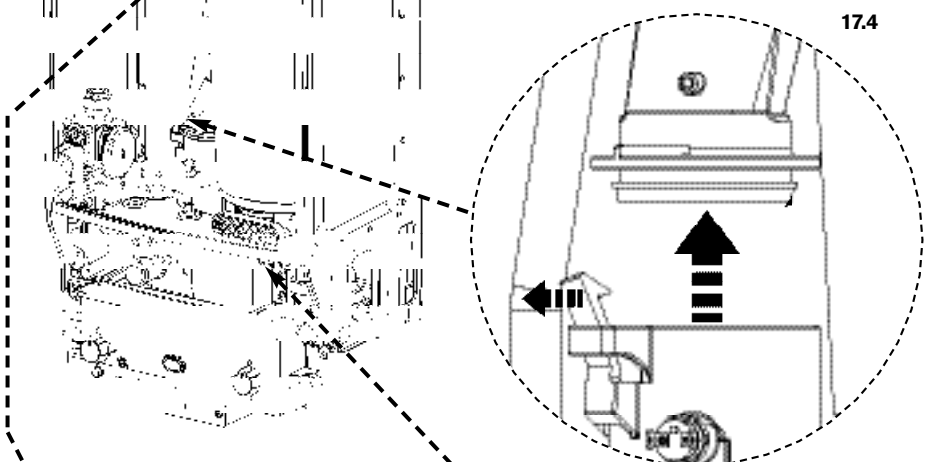

17. Heat Exchanger

- ▶ Remove syphon.
- 17.1 Disconnect both flow pipe elbow wire clips (K) and pull pipe away from the Heat Exchanger
- 17.2 Remove the plastic nut from the bottom of the boiler.
- 17.3 Remove grommet.
- 17.4 Undo flue connection from sump.
- ▶ Pull heat exchanger assembly up to clear.
- ▶ Reassemble and check combustion as stated in the gas conversion section.

NOTE:

After re-assembly, check CO/CO₂ levels as described in the setting of the air/gas ratio section.

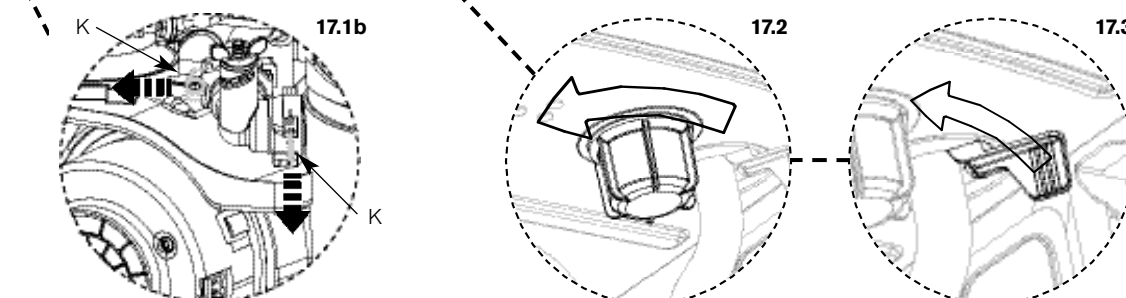

SERVICING & SPARES

SHORT PARTS LIST

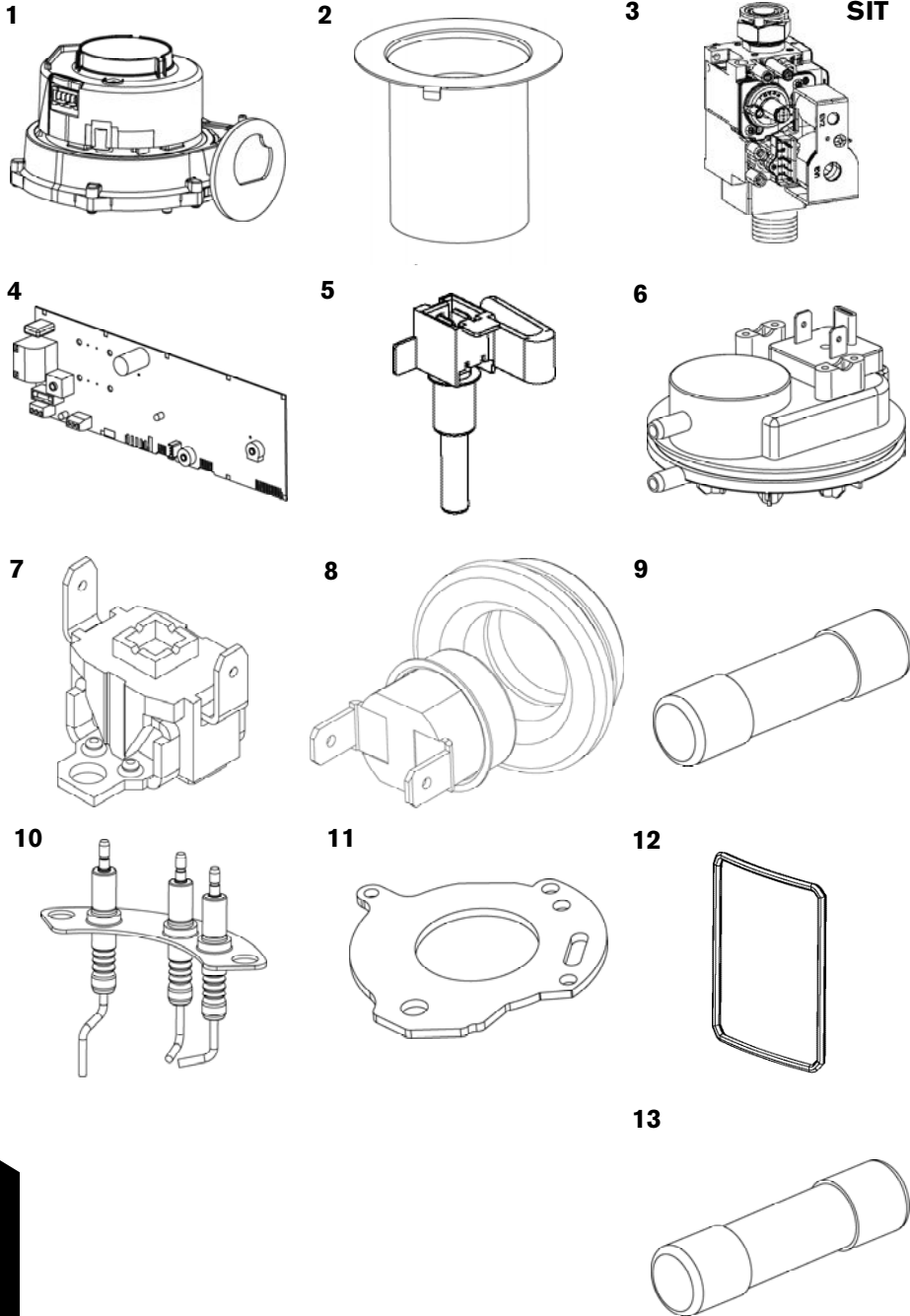

1 Fan	Worcester Part No.	8 717 204 453 0
	GC No.	H26-536
2 Burner	Worcester Part No.	8 718 120 616 0
	GC No.	H26-537
12Ri	Worcester Part No.	8 718 120 616 0
15Ri	GC No.	H26-537
18Ri	Worcester Part No.	8 718 120 619 0
18Ri	GC No.	H26-538
24Ri	Worcester Part No.	8 718 120 619 0
24Ri	GC No.	H26-538
3 Gas valve	Worcester Part No.	8 716 111 325 0
	GC No.	H26-539
12Ri	Worcester Part No.	8 716 111 325 0
15Ri	GC No.	H26-539
18Ri	Worcester Part No.	8 716 111 325 0
18Ri	GC No.	H26-539
24Ri	Worcester Part No.	8 716 111 325 0
24Ri	GC No.	H26-539
4 Control board	Worcester Part No.	8 716 106 399 0
	GC No.	H26-541
5 Control primary temperature sensor	Worcester Part No.	8 716 106 688 0
	GC No.	H26-542
6 Pressure switch	Worcester Part No.	8 716 106 633 0
	GC No.	H26-543
7 Overheat thermostat - heat exchanger	Worcester Part No.	8 707 206 196 0
	GC No.	H26-584
8 Flue overheat thermostat (Grommet type)	Worcester Part No.	8 717 206 213 0
	GC No.	
9 Fuse (F1)	Worcester Part No.	8 716 156 000 0
	GC No.	E26-716
10 Ignition and flame sense electrodes	Worcester Part No.	8 718 107 087 0
	GC No.	H26-544
11 Seal - air gas manifold to heat exchanger	Worcester Part No.	8 716 106 506 0
	GC No.	H26-545
12 Seal - door	Worcester Part No.	8 716 106 635 0
	GC No.	H26-546
13 Fuse (F2)	Worcester Part No.	8 716 156 001 0
	GC No.	

CAUTION: TURN OFF THE GAS SUPPLY AND ISOLATE THE MAINS SUPPLIES BEFORE STARTING ANY WORK AND OBSERVE ALL RELEVANT SAFETY PRECAUTIONS.

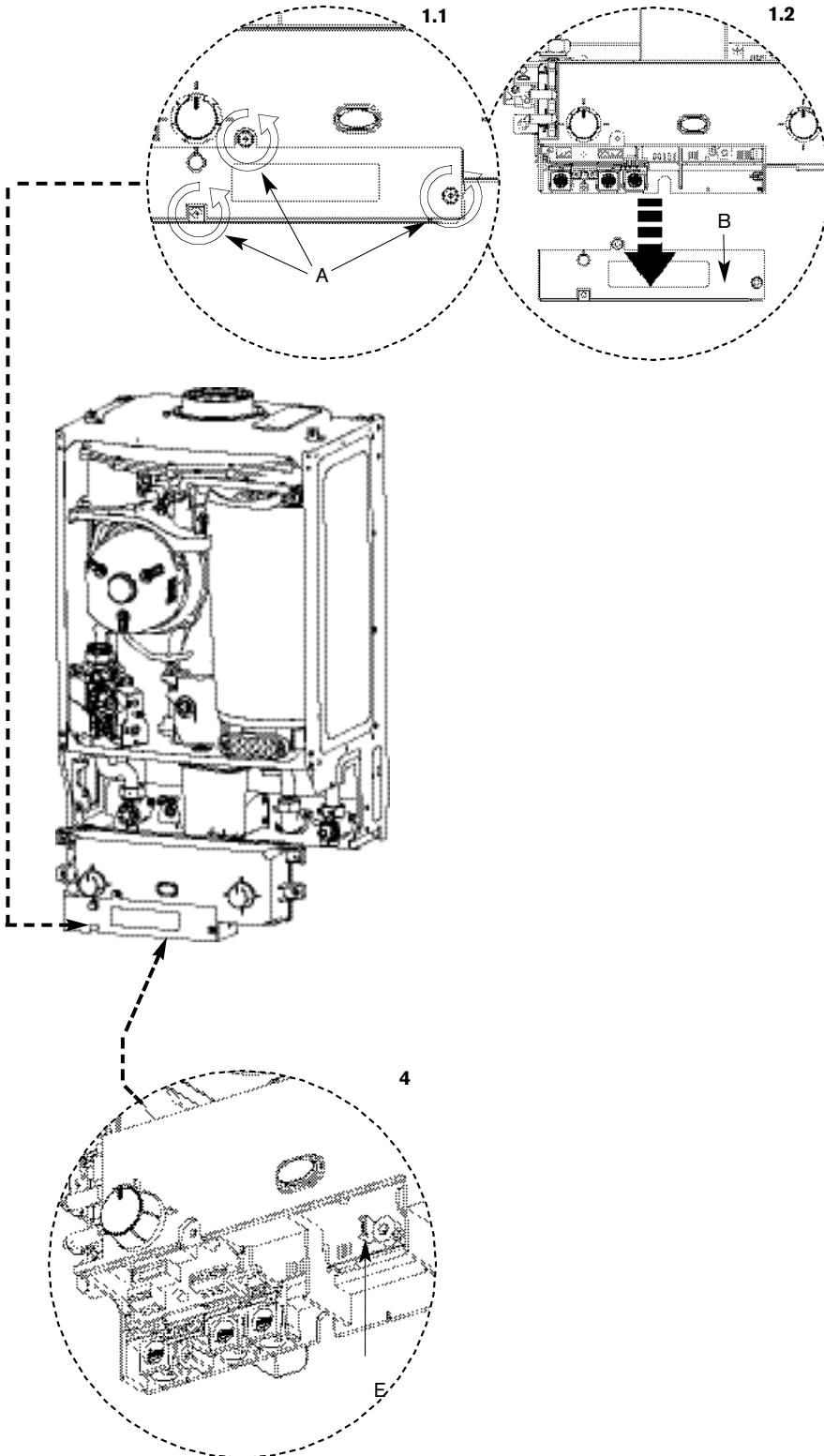

Code plugs

12kW NG	-	1034
12kW LPG	-	1035
15kW NG	-	1036
15kW LPG	-	1037
18kW NG	-	1038
18kW LPG	-	1039
24kW NG	-	1041
24kW LPG	-	1040

GAS CONVERSION

THE SETTING OF THE GAS RATIO MUST BE CARRIED OUT BY A COMPETENT PERSON. SETTING OF THE GAS RATIO MUST **NOT** BE ATTEMPTED UNLESS THE PERSON CARRYING OUT THE CONVERSION IS EQUIPPED WITH A COMBUSTION ANALYSER CONFORMING TO BS 7927 AND IS COMPETENT IN ITS USE.

Important: The appliance shall not be installed into a room or internal space below ground level when it is intended for use with LPG (propane - G31). This does not preclude the installation into a room or space which is a basement on one side of the building but open to ground on the opposite side.

Installation Regulations

In addition to those specified in the main booklet the following standard applies when converting to an LPG appliance: **BS 5842 Domestic Propane Gas Burning Installations.**

All appliances

- ▶ Remove outer casing as described in **Servicing & Spares** section.
- 1.1 Remove 3 screws (A) retaining cover.
- 1.2 Remove cover (B) from control box.

The CO₂ level must be reset:

See 'Setting the gas/air ratio' under **Servicing & Spares** section. After resetting replace arrow on data label to the LPG position.

CO/CO₂ settings for Greenstar Ri

NOTE. CO₂ should be measured after 10 minutes

Gas type	CO ₂ setting maximum	CO ₂ setting minimum
Natural gas	9.8% ± 0.5%	9.2% ± 0.5%
LPG	11.0% ± 0.5%	10.5% ± 0.5%
CO - less than 200ppm (0.002 ratio)		

4. Code plug

- 4.1 Gently pull code plug (E) from control box and replace with new one from LPG conversion kit.
- ▶ Reassemble control box and replace outer case.

For code plug numbers see table at the foot of the page.

CONVERSION KITS

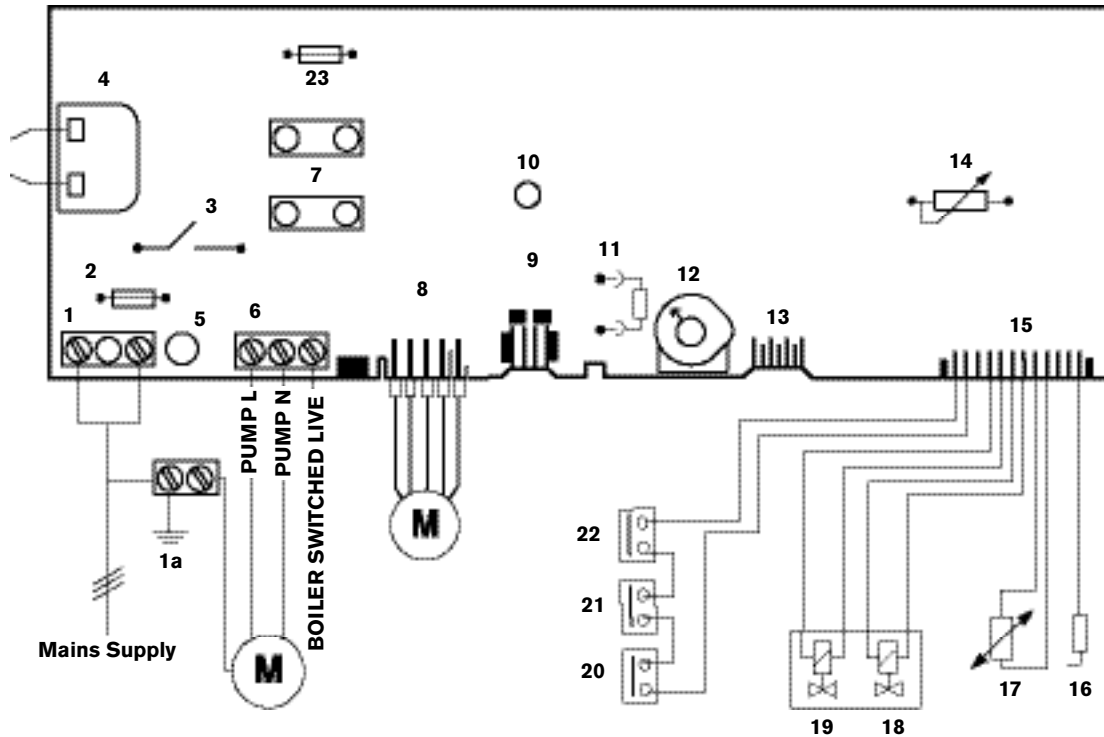

- 1. ST1, Terminal block, 230VAC mains supply.
- 1a. Control box earth connection.
- 2. Fuse F1 (T2A, H250V).
- 3. Boiler mains supply on/off switch.
- 4. Spark transformer.
- 5. Flame indicator.
- 6. ST2, Terminal block for pump & switched live.
- 7. Transformer connectors.
- 8. ST5, Fan 230VAC.
- 9. ST6, Diagnostic interface.
- 10. Indicator lamp for power supply.
- 11. ST7, Code plug.
- 12. S2, Service mode selector switch
- 13. ST8, No connection.
- 14. Temperature control and lockout reset.
- 15. ST9 connector
- 16. Flame sense electrode,
Pin 1 = green.
- 17. Primary NTC sensor,
Pin 4 = red, Pin 5 = red.
- 18. Solenoid valve 1,
Pin 6 = blue, Pin 7 = blue.
- 19. Solenoid valve 2,
Pin 8 = violet, Pin 9 = violet.
- 20. Flue overheat sensor,
Pin 11 = orange.
- 21. High limit stat, (*wired in series with flue overheat sensor & blocked flue protection sensor.*)
- 22. Blocked flue protection sensor,
Pin 12 = orange.
- 23. Fuse F2 (T1.25A, H250V).

NOTE : This fault finding information is for guidance only. Worcester cannot be held responsible for costs incurred by persons not deemed to be competent.

The electronic control system for this boiler incorporates a blue central indicator. This normally confirms the permanent mains supply but, by flashing at different rates during a fault, provides a guide to the cause as listed.

This fault finding system assumes that the appliance has been operating normally until the time of failure (i.e. not a first installation error).

PRELIMINARY CHECKS : Preliminary electrical system checks are the first electrical checks to be carried out during a fault-finding procedure. On completion of the Service/Fault-Finding task which has required the breaking and remaking of electrical connections, check (a) EARTH CONTINUITY, (b) SHORT CIRCUIT CHECK, (c) POLARITY and (d) RESISTANCE TO EARTH.

Indication	Fault	Possible solution/check
No light		Permanent mains supply to boiler. Boiler mains switch on. Fuse F1. Fuse F2. Transformer (both coils below 100Ω). Otherwise replace control board (if boiler does not operate correctly).
Light on but boiler not operating during demand		Boiler demand live at ST2 terminal LR (is there a demand) By pass is open If either only HW or CH is operating check diverter valve/frost stat/room stat/programmer. Otherwise replace control board.
*Slow flash (normally off, flashes on)	Ignition lockout	Gas present and at correct pressure. Combustion CO2 level. Flue condition Ignition electrodes/cables/connections Flame sense electrode/cables/connections Gas valve (coils 140-190Ω). Otherwise replace control board.
*Slow flash (normally on, flashes off)	Flue overheat	Flue temperature too high. Heat exchanger baffles have been removed and not refitted.
	Heat exchanger overheat	Water pressure/dry All air vented Pump/cables/connections Water leaks/blockages Safety thermostats/cables/connections Otherwise replace control board
	Flue pressure switch	Blockage in flue system
Fast flash	Volatile lockout (sensor, fan or code plug)	Temperature sensor (8000 - 20000Ω). Wiring/connections to sensor. Fan/cable/connections. Code plug fitted.
2 pulses		Service mode switch in min position.
5 pulses		Service mode switch in max position.

*Reset via the user control.

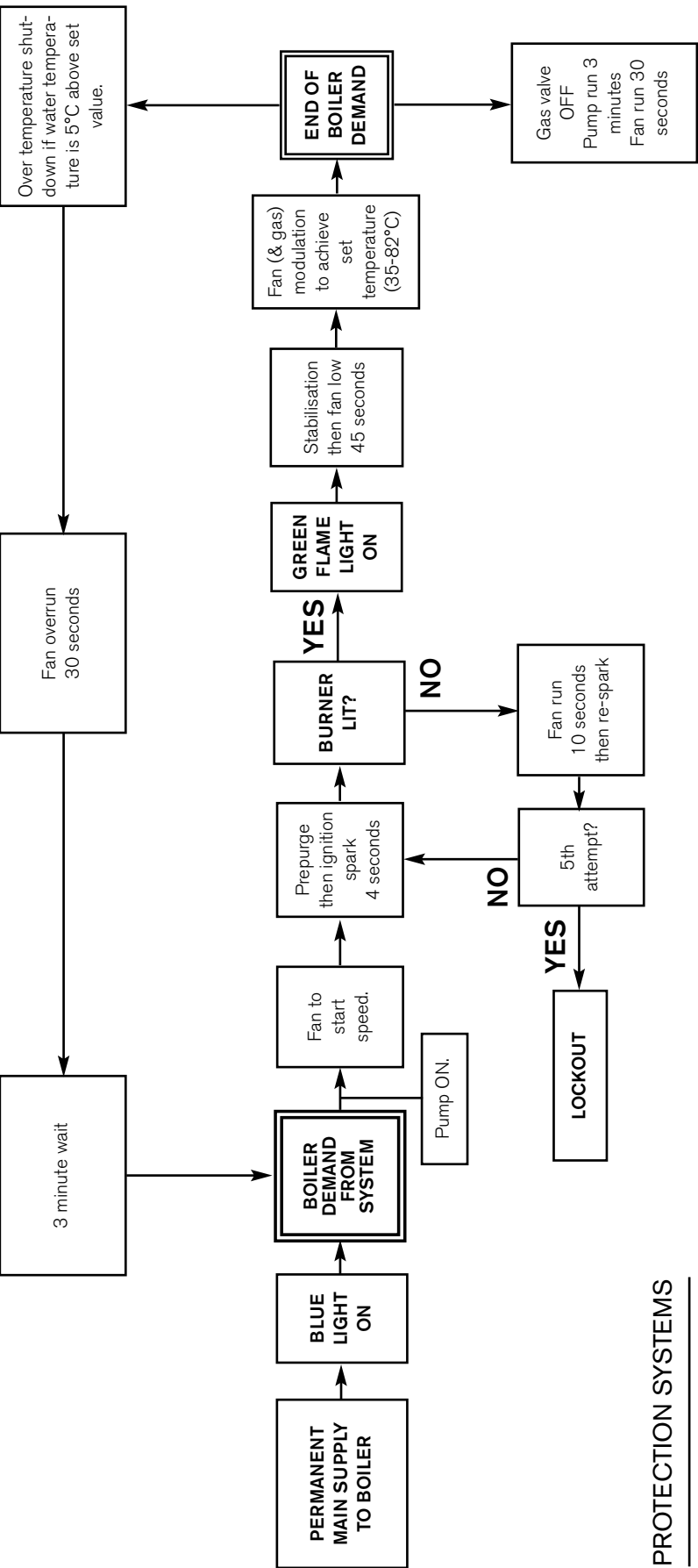

PROTECTION SYSTEMS

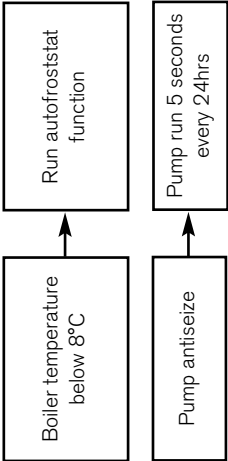

SERVICE RECORD

It is recommended that your heating system is serviced regularly and that the appropriate Service Record is completed.

Service Provider

Before completing the appropriate Service Record below, please ensure you have carried out the service as described in the manufacturer's instructions.

Always use the manufacturer's specified spare part when replacing controls.

SERVICE 1 Date

Energy Efficiency Checklist completed? Yes No

Engineer Name _____

Company Name _____

Telephone Number _____

CORGI ID Number _____

Comments _____

Signature _____

SERVICE 2 Date

Energy Efficiency Checklist completed? Yes No

Engineer Name _____

Company Name _____

Telephone Number _____

CORGI ID Number _____

Comments _____

Signature _____

SERVICE 3 Date

Energy Efficiency Checklist completed? Yes No

Engineer Name _____

Company Name _____

Telephone Number _____

CORGI ID Number _____

Comments _____

Signature _____

SERVICE 4 Date

Energy Efficiency Checklist completed? Yes No

Engineer Name _____

Company Name _____

Telephone Number _____

CORGI ID Number _____

Comments _____

Signature _____

SERVICE 5 Date

Energy Efficiency Checklist completed? Yes No

Engineer Name _____

Company Name _____

Telephone Number _____

CORGI ID Number _____

Comments _____

Signature _____

SERVICE 6 Date

Energy Efficiency Checklist completed? Yes No

Engineer Name _____

Company Name _____

Telephone Number _____

CORGI ID Number _____

Comments _____

Signature _____

SERVICE 7 Date

Energy Efficiency Checklist completed? Yes No

Engineer Name _____

Company Name _____

Telephone Number _____

CORGI ID Number _____

Comments _____

Signature _____

SERVICE 8 Date

Energy Efficiency Checklist completed? Yes No

Engineer Name _____

Company Name _____

Telephone Number _____

CORGI ID Number _____

Comments _____

Signature _____

SERVICE 9 Date

Energy Efficiency Checklist completed? Yes No

Engineer Name _____

Company Name _____

Telephone Number _____

CORGI ID Number _____

Comments _____

Signature _____

SERVICE 10 Date

Energy Efficiency Checklist completed? Yes No

Engineer Name _____

Company Name _____

Telephone Number _____

CORGI ID Number _____

Comments _____

Signature _____

If in the unlikely event the boiler does not give complete satisfaction, before calling for a service engineer, the installer should check the following:-

No Central Heating but Hot Water OK

Unlikely to be a boiler fault, please ask your electrician to check the external controls.

No Hot Water but Central Heating OK

Unlikely to be a boiler fault, please ask your electrician to check the external controls.

No HW or CH demand

Is there a demand from external controls? To eliminate the boiler as a fault, remove the switched live from the wiring centre to LR on ST2, then fit a link between the L on ST1 into LR on ST2 (Pump still connected on Lp and Np). If the boiler and pump run normally then it is likely there is a fault with the external controls. Please contact your electrician.

Burner lights then goes out in HW or CH mode

Does the boiler run normally with the front cover off and then fail when the cover is put back on?

If yes there is likely to be a flue problem - either the air inlet is blocked or the inner flue is leaking flue gases into the air inlet.

Boiler noisy or going to overheat

1. Check that the primary flow (left hand pipe) from the boiler is hotter than the primary return (right hand pipe). If the return is hotter than the flow, then the primary flow and return could be crossed or the pump is fitted backwards.
2. Is the pump live supply taken from Lp on ST2 of the boiler's control board? This boiler requires the pump to be wired directly into the control board to provide pump overrun.
3. Was the system flushed?
4. Check the pump.

General checks

1. Is all the air bled from the gas supply?
2. Is all the air bled from the primary water system?
3. Is 230v a.c. across the boiler live and neutral terminals?(L & N on ST10)
4. Is the polarity correct?
5. Is the incoming gas pressure at least 18mbar with the boiler at maximum output?



8716115164

Pack Number



8716115168

CONTACT INFORMATION

WORCESTER, BOSCH GROUP:

TECHNICAL:	08705 266241
SERVICE:	08457 256206
SPARES:	01905 752571
LITERATURE:	01905 752556
TRAINING:	01905 752526
SALES:	01905 752640
WEBSITE:	www.worcester-bosch.co.uk

Dedicated to heating comfort

Worcester, Bosch Group

Cotswold Way, Warndon, Worcester WR4 9SW.

Tel. 01905 754624 Fax. 01905 754619

Worcester, Bosch Group is a brand name of Bosch Thermotechnology Ltd.

www.worcester-bosch.co.uk

8 716 115 168a (06/2008)

