

Installation and servicing instructions

Wall hung gas fired condensing boiler

# Worcester Commercial Boiler Series GB162-50/65/80/100

For central heating systems and indirect fed domestic hot water



6 720 648 726-000.1TD



Product overview

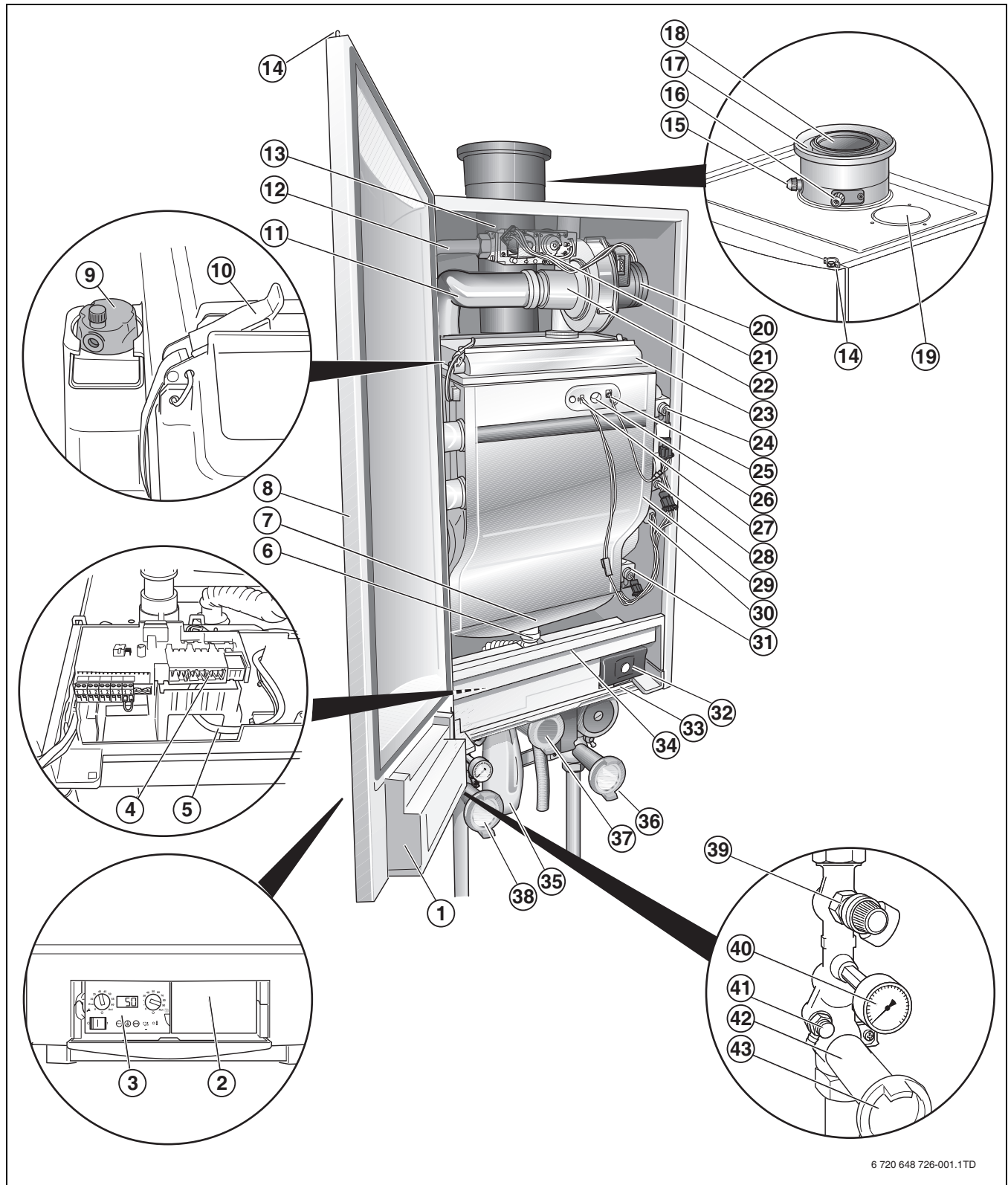

6 720 648 726-001.1TD

Fig. 1 GB162-50/65/80/100 with pump group

- [1] BC10 basic controller holder
- [2] Installation option for room controller, e.g. RC35
- [3] BC10 basic controller, can be expanded e.g. by the RC35 room controller
- [4] Connection box (low-voltage and 230V connections)
- [5] Fan harness and mains lead of the pump
- [6] Condensate drain outlet
- [7] Condensate collector
- [8] Boiler front door
- [9] Automatic air vent
- [10] Quick clip fasteners
- [11] Air inlet pipe
- [12] Gas pipe
- [13] Flue gas pipe
- [14] Door lock
- [15] Testing point for flue gas
- [16] Testing point for air intake
- [17] Air intake connection
- [18] Flue gas connection
- [19] Cover shield
- [20] Fan
- [21] Gas valve
- [22] Venturi
- [23] Burner cover
- [24] Flow temperature sensor
- [25] Ionisation electrode
- [26] Sight glass
- [27] Glow ignitor
- [28] Safety temperature sensor
- [29] Heat exchanger
- [30] Pressure sensor
- [31] Return temperature sensor
- [32] Universal Burner Automatic Version 3 (UBA 3)
- [33] Drawer with function module integration options
- [34] Cover shield
- [35] Condensate trap

Pump group (optional accessory):

- [36] Isolating valve, blue (CH boiler return) with pump, drain cock, non-return valve and thermometer
- [37] Gas valve, yellow (GAS)
- [38] Isolating valve, red (CH boiler flow) with drain cock, pressure gauge, thermometer and 4-bar pressure relief valve
- [39] 4-bar pressure relief valve and securing pin
- [40] Pressure gauge
- [41] Drain valve
- [42] Isolating valve
- [43] Thermometer (optional accessory)

The pump group also includes an insulation cover (see also pump group installation instructions).

**Contents**

<b>1</b>	<b>Key to symbols and safety instructions</b>	<b>5</b>
1.1	Key to symbols	5
1.2	Safety instructions	6
<b>2</b>	<b>General</b>	<b>8</b>
<b>3</b>	<b>Regulations and directives</b>	<b>9</b>
3.1	Designated use	9
3.2	Boiler room	9
3.3	Combustion air flue gas connection	9
3.4	Quality of the heating system water	9
3.5	Quality of the pipework	9
3.6	Maintenance schedule	9
3.7	Applicability of regulations	9
<b>4</b>	<b>Safety</b>	<b>10</b>
4.1	Please observe these instructions	10
4.2	Tools, materials and further equipment	10
4.3	Recycling	10
<b>5</b>	<b>Transport</b>	<b>10</b>
5.1	Lifting and carrying the boiler	10
5.2	Transporting the boiler with a trolley	11
<b>6</b>	<b>Items supplied with boiler</b>	<b>11</b>
<b>7</b>	<b>Dimensions of boiler</b>	<b>12</b>
<b>8</b>	<b>Installation</b>	<b>14</b>
8.1	Installing the boiler	14
8.2	General connection of mains water and gas components	15
8.2.1	General	15
8.2.2	Install the water and gas connections to the boiler using a pump group (accessory)	15
8.2.3	Install the water and gas connections to the boiler without a pump group	15
8.2.4	Installing the differential pressure controller	16
8.2.5	Installing the isolating valves	16
8.2.6	Installing the drain cock	16
8.2.7	Installing a pressure relief valve	16
8.2.8	Selecting and installing the pump	16
8.2.9	Installing the condensate trap	17
8.2.10	Condensate removal	17
8.2.11	Connecting the condensate drain pipe	19
8.2.12	Connecting the expansion vessel in a single-boiler system	19
8.3	Flue Installation	20
8.3.1	Siting the flue terminal	20
8.3.2	Air supply and flue gas exhaust in a room sealed installation	21
8.3.3	Maximum Flue length (L)	22
8.3.4	Additional flue parts	22

8.3.5	Standard 100 mm flue systems	22
8.3.6	Installation of the horizontal flue	23
8.3.7	Flue pipe preparation and assembly	23
8.4	Flue gas connection	23
8.4.1	Open flue operation	23
8.4.2	Room sealed operation	23
8.4.3	Flue material	23
8.4.4	Calculating the air intake and flue gas pipe dimensions	23
8.5	Electrical connections	24
8.5.1	Electrical wiring diagram	25
8.5.2	Terminal strip connections	26
8.5.3	Routing the cable through the boiler	26
8.5.4	Description of the terminal strip connections	26
8.5.5	230 V connections (only for GB162-50/65)	29
8.5.6	Installing function modules (accessories)	30
<b>9</b>	<b>Operation</b>	<b>32</b>
9.1	General items	32
9.2	BC10 control operating instructions	33
<b>10</b>	<b>Commissioning</b>	<b>37</b>
10.1	Filling the heating system	37
10.1.1	Filling the heating system	37
10.1.2	Filling the condensate trap with water	38
10.2	Testing and measuring	38
10.2.1	Checking for gas leaks	38
10.2.2	Bleeding the gas flow pipe	39
10.2.3	Gas consumption test	39
10.2.4	Checking the flue gas connection	40
10.2.5	Checking the appliance configuration	40
10.2.6	Measuring the gas inlet pressure (working pressure)	40
10.2.7	Checking and adjusting the gas/air-ratio	41
10.2.8	Carrying out a leakage test in operating conditions	42
10.2.9	Measuring the flue gases CO <sub>2</sub> emissions	43
10.2.10	Carrying out a function test	43
10.2.11	Measuring the ionisation current	43
10.3	Boiler settings	44
10.3.1	Setting the heating capacity	44
10.3.2	Setting the maximum CH flow temperature	44
10.3.3	Setting the pump run-over time	44
10.3.4	Switching DHW mode on/off	44
10.3.5	Setting the DHW temperature	44
10.4	Final activities	45
10.4.1	Closing the boiler door and the control panel	45
10.4.2	Handing over	45
10.5	Commissioning record log book	45
<b>11</b>	<b>Shutting down the heating system</b>	<b>46</b>
11.1	Shutting down the heating system using the basic controller	46
11.2	Shutting down the heating system if there is a risk of freezing (interruption of use)	46
<b>12</b>	<b>Inspection</b>	<b>46</b>
12.1	Preparing the heating system for inspection	46
12.2	Opening the boiler door	47

12.3	Carry out a visual check for general signs of corrosion .....	47
12.4	Gas valve leakage test .....	47
12.5	Measuring the ionisation current .....	47
12.6	Measuring the gas inlet pressure (working pressure) .	47
12.7	Checking and adjusting the gas/air-ratio .....	47
12.8	Carrying out a leakage test in operating conditions ...	47
12.9	Measuring the flue gases CO <sub>2</sub> emissions .....	47
12.10	Filling the heating system .....	47
12.11	Checking the flue gas connection .....	47
12.12	Inspection log book .....	48

**13 Maintenance ..... 48**

13.1	Removing the boiler door .....	48
13.2	Cleaning the heat exchanger, burner and condensate trap .....	49
13.2.1	Removing the gas valve .....	49
13.2.2	Removing the burner cover with the fan and the gas valve .....	49
13.2.3	Removing the burner and the burner seal .....	50
13.2.4	Checking ignition unit .....	50
13.2.5	Disconnecting the condensate trap .....	51
13.2.6	Removing the condensate collector .....	51
13.2.7	Cleaning the heat exchanger .....	52
13.3	Checking and adjusting the gas/air-ratio .....	52
13.4	Function check in operating conditions .....	52
13.5	Service record log book .....	52

**14 Display information ..... 53**

14.1	Removing the control panel from the boiler .....	53
14.2	Display readings .....	53
14.3	BC10 Display settings .....	54
14.4	BC10 Display codes .....	54
14.5	Re-fit the control panel in the boiler .....	60

**15 Technical specifications ..... 61**

15.1	Spare parts list GB162-80/100 .....	63
15.2	Spare parts list GB162-50/65 .....	66

**1 Key to symbols and safety instructions**

**1.1 Key to symbols**

**Warnings**

	Warnings in this document are framed and identified by a warning triangle which is printed on a grey background.
---	--

	Electrical hazards are identified by a lightning symbol surrounded by a warning triangle.
---	---

Keywords indicate the seriousness of the hazard in terms of the consequences of not following the safety instructions.

- **NOTICE** indicates that material damage may occur.
- **CAUTION** indicates that minor to medium injury may occur.
- **WARNING** indicates that serious injury may occur.
- **DANGER** indicates possible risk to life.

**Important information**

	Important information in cases where there is no risk of personal injury or material losses is identified by the symbol shown on the left. It is bordered by horizontal lines above and below the text.
---	---

**Additional symbols**

Symbol	Meaning
▶	a step in an action sequence
→	a reference to a related part in the document or to other related documents
•	a list entry
–	a list entry (second level)

Table 1

**PLEASE READ THESE INSTRUCTIONS CAREFULLY BEFORE STARTING INSTALLATION.**

THESE INSTRUCTIONS ARE APPLICABLE TO THE WORCESTER APPLIANCE MODEL(S) STATED ON THE FRONT COVER OF THIS MANUAL ONLY AND MUST NOT BE USED WITH ANY OTHER MAKE OR MODEL OF APPLIANCE.

THE INSTRUCTIONS APPLY IN THE UK AND IRELAND ONLY AND MUST BE FOLLOWED EXCEPT FOR ANY STATUTORY OBLIGATION. THIS APPLIANCE MUST BE INSTALLED BY A GAS SAFE REGISTERED, COMPETENT PERSON. FAILURE TO INSTALL CORRECTLY COULD LEAD TO PROSECUTION.

IF YOU ARE IN ANY DOUBT CONTACT THE WORCESTER TECHNICAL HELPLINE (0330 123 3366).

DISTANCE LEARNING AND TRAINING COURSES ARE AVAILABLE FROM WORCESTER.

PLEASE LEAVE THESE INSTRUCTIONS WITH THE COMPLETED INSTALLATION CHECKLIST, (OR A CERTIFICATE CONFIRMING COMPLIANCE WITH IS 813, EIRE ONLY) AND THE USER MANUAL WITH THE OWNER OR AT THE GAS METER AFTER INSTALLATION OR SERVICING.

THE INSTALLATION CHECKLIST CAN BE FOUND IN THE BACK PAGES OF THIS INSTALLATION MANUAL.

ABBREVIATIONS USED IN THIS MANUAL:

Ø	Diameter
AB	Automatic Bypass
AIC	Air Intake Connection
AV	Air Vent (automatic)
BC10	Basic Controller
CB	Connector Block
CDO	Condensate drain outlet
CH	Central Heating
CHF	Central Heating Flow
CHR	Central Heating Return
CT	Cylinder Thermostat
DHW	Domestic Hot Water
DV	Diverter Valve
E	Earth
FGC	Flue gas Connection
HK1	Heating circuit 1
HK2	Heating circuit 2
IP	Ingress Protection
BCM	Boiler identification Module
L	Live
LPG	Liquid Petroleum Gas
LSV	Lock Shield Valve
MCW	Mains Cold Water
N	Neutral
NG	Natural Gas
NTC	Negative Temperature Coefficient (sensor)
JB	Junction Box / 230 Volt Converter
PF	Pump group Flow
PL	Permanent Live
PR	Pump group Return
Prog	Programmer
PRV	Pressure Relief Valve
RT	Room Thermostat
T	Timer
TRV	Thermostatic Radiator Valve
WC	Wiring Centre

Table 2 Abbreviations

## 1.2 Safety instructions

### IF YOU SMELL GAS:

- ▶ **CALL NATIONAL GAS EMERGENCY SERVICE ON 0800 111 999.**
- ▶ **LPG BOILERS CALL THE SUPPLIER'S NUMBER ON THE SIDE OF THE LPG TANK.**
- ▶ **TURN OFF THE ECV (EMERGENCY CONTROL VALVE) AT THE METER/REGULATOR.**
- ▶ **DO NOT TURN ELECTRICAL SWITCHES ON OR OFF.**
- ▶ **DO NOT STRIKE MATCHES OR SMOKE.**
- ▶ **PUT OUT NAKED FLAMES.**
- ▶ **OPEN DOORS AND WINDOWS.**
- ▶ **KEEP PEOPLE AWAY FROM THE AFFECTED AREA.**

### BOILER OPERATION:

**This boiler must only be operated by a responsible adult who has been instructed in, understands, and is aware of the boiler's operating conditions and effects.**

### HEALTH AND SAFETY

The appliance contains no asbestos and no substances have been used in the construction process that contravene the COSHH Regulations (Control of Substances Hazardous to Health Regulations 1988).

### COMBUSTION AND CORROSIVE MATERIALS

Do not store or use any combustible materials (paper, thinners, paints etc.) inside or within the vicinity of the appliance.

Chemically aggressive substances can corrode the appliance and invalidate any warranty.

### FITTING AND MODIFICATIONS

Fitting the appliance and any controls to the appliance may only be carried out by a competent engineer in accordance with the current Gas Safety (Installation and Use) Regulations.

Flue systems must not be modified in any way other than as described in the fitting instructions. Any misuse or unauthorised modifications to the appliance, flue or associated components and systems could invalidate the warranty. The manufacturer accepts no liability arising from any such actions, excluding statutory rights.

### SERVICING

Advise the user to have the system serviced annually by a competent, qualified Gas Safe registered engineer. Approved spares must be used to help maintain the economy, safety and reliability of the appliance.

### IMPORTANT

The service engineer must complete the Service Record on the Installation Checklist after each service.

### INSTALLATION REGULATIONS

Current Gas Safety (Installation & Use) Regulations:

All gas appliances must be installed by a competent person in accordance with the above regulations. Failure to install appliances correctly could lead to prosecution.

The appliance must be installed in accordance with, and comply to, the current: Gas Safety Regulations, IEE Regulations, Building Regulations, Building Standards (Scotland) (Consolidation), Building Regulations (Northern Ireland), local water by-laws, Health & Safety Document 635 (The Electricity at Work Regulations 1989) and any other local requirements.

### Directives:

- 2009/142/EEC gas appliance directive
- 92/42/EEC boiler efficiency directive
- 73/23/EEC low voltage directive
- 89/336/EEC EMC directive
- 97/23/EC pressure equipment directive
- any relevant requirement of the local authority.

### British Standards:

Where no specific instruction is given, reference should be made to the relevant British Standard codes of Practice.

BS4814:1 Specification for expansion vessels using an internal diaphragm, for sealed hot water heating systems.

BS5482 Code of practice for domestic butane- and propane gas-burning installations. Installations at permanent dwellings, residential park homes and commercial premises, with installation pipework sizes not exceeding DN 25 for steel and DN 28 for corrugated stainless steel or copper.

BS6281:1 Devices without moving parts for the prevention of contamination of water by backflow. Specification for type A air gaps.

BS6282:1 Devices with moving parts for the prevention of contamination of water by backflow. Specification for check valves of nominal size up to and including DN 54.

BS6283:4 Safety and control devices for use in hot water systems. Specification for drop-tight pressure

	reducing valves of nominal size up to and including DN 50 for supply pressures up to and including 12 bar.
BS6880	Code of practice for low temperature hot water heating systems for output greater than 45 kW.
BS6891	Installation of low pressure gas pipe work up to 35 mm (R1¼") in domestic premises (2 <sup>nd</sup> family gas).
BS7074:1	Code of practice for domestic and hot water supply.
BS7671	Requirements for Electrical Installations IEE Wiring Regulations seventeenth edition.
BS EN 303-7	Heating boilers. Gas-fired central heating boilers equipped with a forced draught burner of nominal heat output not exceeding 1000 kW.
CISBE	Guide Reference sections B7, B11 and B13.
CP 342-2	Code of practice for centralized hot water supply. Buildings other than individual dwellings.
IGE/UP/2	Gas installation pipework and compressors on industrial and commercial premises.
IGE/UP/10	Installation of gas appliances in industrial and commercial premises, part 1: flued appliances.
EN12828	Central heating for domestic premises.
<b>Installation not exceeding 70 kW rated input</b>	
BS5440:1	Flues and ventilation for gas appliances of rated heating not exceeding 70 kW (net): Flues.
BS5440:2	Flues and ventilation for gas appliances of rated heating not exceeding 70 kW (net): Air Supply.
BS5449	Specification for forced circulation hot water central heating systems for domestic premises.
BS5546	Installation of gas hot water supplies for domestic purposes.
BS6798	Installation of gas fired boilers of rated input up to 70 kW (net).
BS7593	Treatment of water in domestic hot water central heating systems.
BS EN 483	Gas-fired central heating boilers. Type C boilers of nominal heat input not exceeding 70 kW.
BS EN 677	Gas-fired central heating boilers. Specific requirements for condensing boilers with a nominal heat input not exceeding 70 kW.

**Installation of rated input greater than 70 kW**

BS 6644	Specification for Installation of gas-fired hot water boilers of rated inputs between 70 kW (net) and 1.8 MW (net) (2 <sup>nd</sup> and 3 <sup>rd</sup> family gases).
BS EN 15417	Gas-fired central heating boilers. Specific requirements for condensing boilers with a nominal heat input greater than 70 kW but not exceeding 1000 kW.
BS EN 15420	Gas-fired central heating boilers. Type C boilers of nominal heat input exceeding 70 kW, but not exceeding 1000 kW.

**Irish Standards**

The relevant Irish standards should be followed, including:

- ECTI National rules for electrical installations
- IS 813:2002 for Domestic Gas Installations.

**Health and Safety Document No. 635.**

**Ventilation Requirements**

BS5440:2	(up to a total boiler rating of 70 kW input).
BS6644	(Total boiler rating of 70 kW to 2000 kW input).

**The manufacturer's notes must not be taken, in any way, as overriding statutory obligations.**

The design and construction of the Worcester Wall hung gas fired condensing boiler conforms to the basic specifications listed in the European directive governing gas-fired appliances 2009/142/EEC, and with respect to EN 625, EN 483 and EN 677.



Observe the corresponding technical rules and the building supervisory and statutory regulations when installing and operating the system.



**WARNING:** Keep the control unit housing **closed** when working on water-bearing components.

- The boiler is designed exclusively for heating water as part of a central heating system and/or hot-water system.
- For optimum, long-term reliable functioning of the boiler, and in order to be able to claim under the terms of the manufacturer's warranty. The boiler must be inspected and maintained at least once a year (under normal operating conditions) by a Gas Safe / ACS registered installation and service engineer.
- When instructions are not followed, warranty is invalid.
- Condensing boilers work more efficiently if the return temperature is as low as possible.

**LPG Installations**

An appliance using L.P.G. must not be installed in a room or internal space below ground level unless one side of the building is open to the ground.

**Timber framed building:**

Where the boiler is to be fitted to a timber framed building the guidelines laid down in BS5440: Part 1 and IGE "Gas Installations in Timber Frame Buildings" should be adhered to.

**Bathroom Installations**

This appliance is rated IP X4D.

The boiler may be installed in any room or internal space, although particular attention is drawn to the requirements of the current IEE (BS 7671) Wiring Regulations. In Scotland, the electrical provisions of the building regulations applicable in Scotland, with respect to the installation of the boiler in a room or internal space containing a bath or shower.

If the appliance is to be installed in a room containing a bath or shower then, providing water jets are not going to be used for cleaning purposes (as in communal baths/showers), the appliance can be installed in Zone 3, as detailed in BS 7671.

**Compartment Installations**

A compartment used to enclose the boiler should be designed and constructed especially for this purpose. An existing cupboard or compartment may be used, provided that it is modified for the purpose.

In both cases, details of essential features of cupboard/compartment design, including airing cupboard installation, are to conform to the following: BS 6798 (No cupboard ventilation is required - see 'Air Supply' for details).

It is not necessary to have a purpose-provided air vent in the room or internal space in which the boiler is installed. Neither is it necessary to ventilate a cupboard or compartment in which the boiler is installed, due to the low surface temperatures of the boiler casing during operation; therefore the requirements of BS 6798, Clause 12, and BS 5440:2 may be disregarded.

See for the required service clearances fig. 6 and fig. 7.

The position selected for installation **must** allow adequate space for servicing in front of the boiler.

- in front: 550 mm
- below: 350 mm
- right side: 0 mm
- left side: 0 mm
- above: 40 mm.

In addition, sufficient space may be required to allow lifting access to the wall mounting bracket. Wall-mounted condensing gas system boilers must only be used with Worcester flue gas systems, which are certified with this type of boiler.

Observe the relevant standards, regulations and legislation of the country or region of final use.



**CAUTION:** Use this device for its intended purpose only.



**DANGER:**

Notes relating to the heating system water.

- ▶ Thoroughly clean and flush the system before it is filled with water. Use only unsoftened mains water with the correct dosage of an approved water treatment product such as Sentinel X100 to fill and top up the system. For more information about Sentinel call 0151 420 9563.
- ▶ When using water treatment, only products suitable for use with Worcester heat exchangers are permitted (e.g. Sentinel X100). Your warranty is at risk if an incorrect water treatment product is used in conjunction with this appliance. For more information, contact Worcester Technical Product Support Department.
- ▶ It is most important that the correct concentration of the water treatment product is maintained in accordance with the manufacturer's instructions.
- ▶ If the boiler is used in an existing system any unsuitable additives **must** be removed by thorough cleaning. BS 7593 details the steps necessary to clean a central heating system.
- ▶ In hard water areas, treatment to prevent lime scale may be necessary - however, the use of artificially softened water is **not** permitted.
- ▶ Under no circumstances should the boiler be fired before the system has been thoroughly flushed.
- ▶ Do not use artificially softened water.
- ▶ Only plastic pipework containing a polymeric barrier should be used. Copper pipework must be used for the first 600 mm.

**Safe handling of substances:**

No asbestos, mercury or CFCs are included in any part of the boiler and its manufacture.

**Potable water:**

All seals, joints and compounds (including flux and solder) and components used as part of the secondary domestic water system must be approved by WRAS.

**CH Water:**

Artificially softened water must not be used to fill the central heating system.

## 2 General

These installation and maintenance instructions apply to the following wall-mounted condensing gas boilers:

- GB162-50
- GB162-65
- GB162-80
- GB162-100.

The name of the boiler is made up of the following components:

- GB: Condensing gas boiler
- 162: Type
- 50, 65, 80 or 100: heating range in kW.

The GB162-50/65/80/100 is suitable for use as a single boiler or as part of a cascade system.

The following technical documentation is available for the GB162-50/65/80/100:

- Installation and maintenance instructions
- User Manual
- Technical product guide.

If you have any suggestions for improvement or have found any discrepancies, please do not hesitate to contact us.

**CE label**



The appliance complies with the basic requirements of the relevant European directives. Conformity has been substantiated by the proper documents which, together with the declaration of conformity, are filed with the manufacturer.

**Energy efficiency**

Energy efficiency information is given in the User Instructions of the appliance.

**Frost protection**

The boiler has integrated frost protection.

The frost protection switches the boiler on at a CH flow temperature of 7 °C and switches it off at a CH flow temperature of 15 °C.

The central heating system is not protected against frost.



If there is a risk of radiators or pipe sections freezing up, we recommend setting the pump over-run time to 24 hours. See section 14.3, page 54.

**Pump test**

If the boiler has not received a heat demand for approximately 4 weeks, the pump will automatically cycle for 10 seconds every 24 hours. This pump test is first carried out for 24 hours when first switched back on.

**Important general instructions for use**

Only use the boiler in accordance with its designated use and the installation and maintenance instructions. Installation, maintenance and repair must be carried out by competent service engineers (e.g. Gas Safe registered).

Only use the boiler in conjunction with the accessories and spare parts indicated in the installation and maintenance instructions. Other accessories and consumables may only be used if they are specifically provided for the designated use and if system performance and safety are not affected in any way.

The boiler is suitable for connection to fully pumped, sealed water systems **only**. Arrangements for draining the system by draining valves must be provided in the installation pipework.

**Subject to technical modifications**

As a result of our policy of constant development, there may be small differences between illustrations, functional steps and technical data.

## Hand over

Please complete the appropriate sections on completion of the installation and commissioning in the relevant log book and hand it over to the end user.

## 3 Regulations and directives

### 3.1 Designated use

The boiler may only be used to heat up water for heating systems and/or domestic hot water (DHW) systems.

The boiler can be installed either as a single system or as part of a multiple system (cascade system). A cascade system enables several boilers of this type to be connected together, where a maximum of 8 boilers with a total capacity of 800 kW can be connected together on a floor surface of approximately 2 m<sup>2</sup>.

Special cascade units (accessories) have been developed to enable this boiler to be installed in a cascade system. Every cascade unit includes an installation frame, horizontal headers, connection pipes for the boiler, main gas pipe and vertical low loss header.

Cascade units are available for installing the boilers in line or back-to-back. These cascade units make installing a cascade system easier and less labour intensive. Please contact your dealer or the manufacturer for further information about cascade systems.

The construction and operating behaviour of the boiler are in accordance with the requirements listed:



The appliance complies with the basic requirements of the relevant European directives.

Conformity has been substantiated by the proper documents which - together with the declaration of conformity - are filed with the manufacturer.

### 3.2 Boiler room



#### CAUTION:

Damage to the installation due to frost.

- ▶ Install the heating system in a room which is free from frost.



#### WARNING:

Fire hazard due to flammable materials or liquids.

- ▶ Do not store any flammable materials or liquids in the direct vicinity of the boiler.

- ▶ Observe all statutory building regulations applying to the place of installation.



#### CAUTION:

Boiler damage due to contaminated combustion air or contaminated air in the boiler room.

- ▶ Never use the boiler in an environment which contains lots of dust or aggressive chemicals. Such as spray shops, hairdresser's shops, agricultural enterprises (manure) or locations where trichloroethylene or hydrogen halides (e.g. contained in aerosols, certain adhesives, solvents or detergents, paints) and other aggressive chemicals are used or stored.
- ▶ In such situations you must opt for a room sealed installation.

The boiler can only be mounted to the wall or installed in a cascade system. When installed in a room with thin walls or a thin floor, resonating noise may occur. Install noise reducing parts if required.

### 3.3 Combustion air flue gas connection

If the boiler is operated dependent on room air, the installation room must have the required air vents. **Do not** obstruct these vents. The air vents must always be free.

### 3.4 Quality of the heating system water

Thoroughly clean and flush the system before filling it. Use only unsoftened mains tap water when filling or topping up the system. The use of dirty water will lead to build-ups of sludge and corrosion, which can in turn result in malfunctioning of the boiler and damage to the heat exchanger.

Inhibit the system with the correct dosage of an approved product.

**Do not** treat the water with antifreeze or water softeners.

The pH of the heating system water **must** be between 7 and 8.5. If this is not the case, please contact Worcester Customer Service before proceeding.



#### CAUTION:

Boiler damage due to corrosion.

- ▶ If the boiler is used in systems with gravitation circulation or in open systems, the boiler circuit must be isolated from the rest of the system by means of a (plate-type) heat exchanger.

### 3.5 Quality of the pipework

When using plastic pipework in the heating system, e. g. for floor heating, it has to be oxygen-tight according to relevant UK-Standards. If the plastic pipes do not comply with these standards, the system parts must be isolated using heat exchangers.

### 3.6 Maintenance schedule

The activities to be included in an annual inspection and maintenance contract can be found in the service section of this manual (→ pages 48 and 52).

If inspection reveals a situation which makes maintenance activities necessary, these activities have to be carried out (→ chapter 13 "Maintenance", page 48).



#### NOTICE:

Damage to the installation due to insufficient or improper cleaning and maintenance.

- ▶ Inspect and clean the heating system as required once a year.
- ▶ Carry out maintenance as required. Immediately remedy faults. This will avoid further damage to the system.

### 3.7 Applicability of regulations

Changes or amendments to the regulations also apply at the time of installation and have to be complied with.

## 4 Safety

Please observe these instructions for your own safety.

### 4.1 Please observe these instructions

Observe the following instructions when installing and operating the heating system:

- The local building regulations as regards the installation conditions.
- The local building regulations as regards fresh air supply and air exhaust facilities and flue connections.
- The regulations for electrical connections to the power supply.
- The gas utility company rules for connecting the gas burner to the local gas mains.
- The regulations and standards concerning the safety facilities for the DHW/heating system.
- The installation instructions for producers of heating systems.



**DANGER:**  
Danger of fatal accident from explosive fumes. If you smell gas, there is a danger of explosion.

- ▶ No naked lights. No smoking. Do not use lighters.
- ▶ DO NOT operate any device that is likely to produce sparks. Do not operate any electrical switches, including telephones, plugs or doorbells.
- ▶ Shut off the main gas supply.
- ▶ Open doors and windows.
- ▶ Warn the residents but do not ring doorbells.
- ▶ Contact the gas utility company from a telephone located outside the building.
- ▶ If you can hear gas leaking out, evacuate the building immediately, prevent other persons from entering, and notify the police and fire service immediately (from a telephone **outside** the building).



**DANGER:**  
Danger of fatal accident from explosive fumes.

- ▶ Only carry out work on gas pipes and fittings if you are Gas Safe / ACS registered.



**DANGER:**  
Danger of fatal accident due to poisoning. Dangerous flue gas can escape if the air supply is insufficient.

- ▶ Make sure that air vents are not reduced in size or obstructed.
- ▶ The boiler may only be operated after the defect has been remedied.
- ▶ Warn the user of the system of the defect verbally and in writing.

- The condensing gas boiler may only be used with the combustion air/flue gas systems designed and approved specifically for this type of boiler.
- Note: in certain areas permits are required for the flue gas system and for connecting the condensate water drain to the public sewage network.

### 4.2 Tools, materials and further equipment

Boiler installation and maintenance requires standard tools for heating, gas and water installation.

In addition you will need a hand truck/cart with a securing strap.

### 4.3 Recycling

- ▶ Dispose of the boiler's packaging material in an environmentally friendly manner.
- ▶ Dispose of those components of the heating installation (e. g. boiler or controller) which have to be replaced in an environmentally friendly manner by handing them in at an authorised recycling facility.

## 5 Transport

This chapter describes how to transport the boiler safely and without damaging it.



**CAUTION:** Damage to the installation due to impacts. The boiler contains parts which can be damaged by impacts.

- ▶ During further transport all parts must be protected against impacts.
- ▶ Observe the transport symbols and instructions on the packaging.



**CAUTION:** Damage to the installation due to external contamination. Proceed as follows if the boiler has been unpacked but is not put into operation yet:

- ▶ Protect the boiler connections against pollution by leaving the protective covers on the connections.
- ▶ Cover the flue gas injectors at the top of the boiler with plastic film.

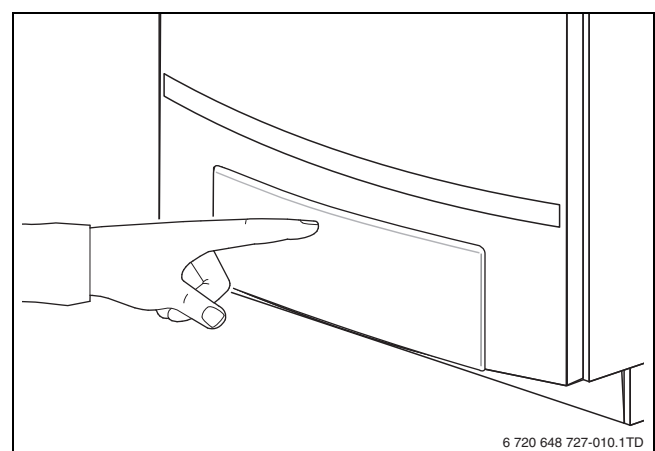



Fig. 2 Open cover panel

### 5.1 Lifting and carrying the boiler

To lift and carry the boiler, place one hand at the bottom of the boiler and the other hand on its front (→ fig. 3).



**CAUTION:** Damage to the unit due to it being lifted and carried incorrectly.

- ▶ Do not hold the boiler by the door over the control panel (→ fig. 4) to lift and carry it.

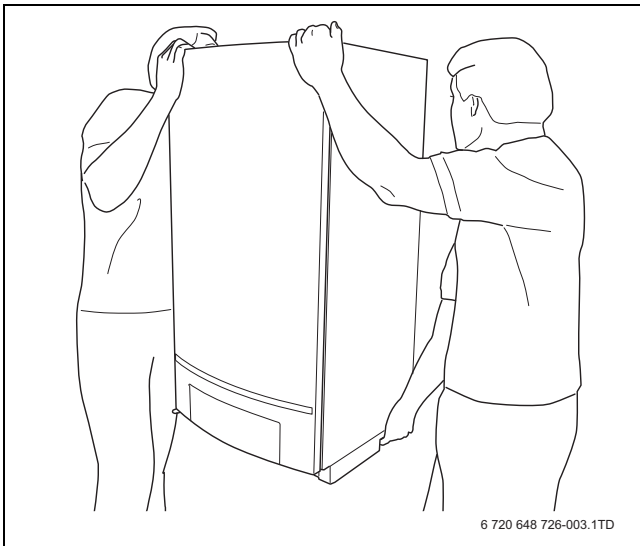

Fig. 3 Lift and carry the boiler correctly

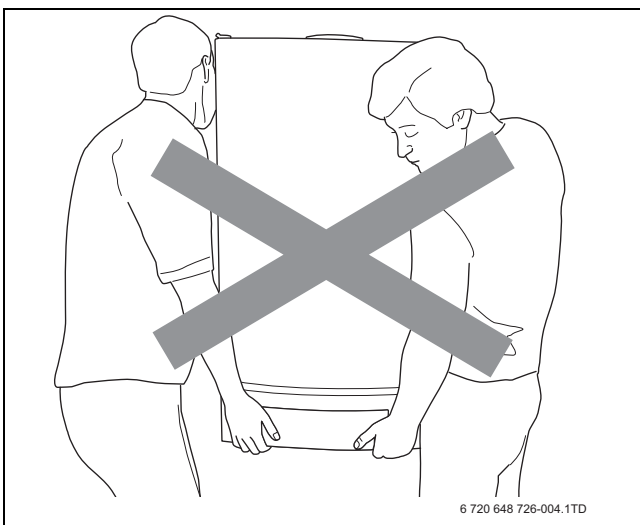

Fig. 4 Incorrect way of lifting and carrying the boiler

## 5.2 Transporting the boiler with a trolley



**DANGER:** Danger of injury due to improperly secured boiler.

- ▶ Use proper transport equipment, such as a trolley with a securing strap, a stair-climbing hand truck or a convertible hand truck to transport the boiler.
- ▶ Secure the boiler on the transportation equipment to prevent it falling off.

- ▶ Place the boiler in its packaging on the hand truck and secure it with a strap if necessary.
- ▶ Transport the boiler to the installation location.

## 6 Items supplied with boiler

The boiler is delivered factory-assembled.

- ▶ Check that the packaging is intact upon delivery.
- ▶ Check that all items have been supplied with the boiler.

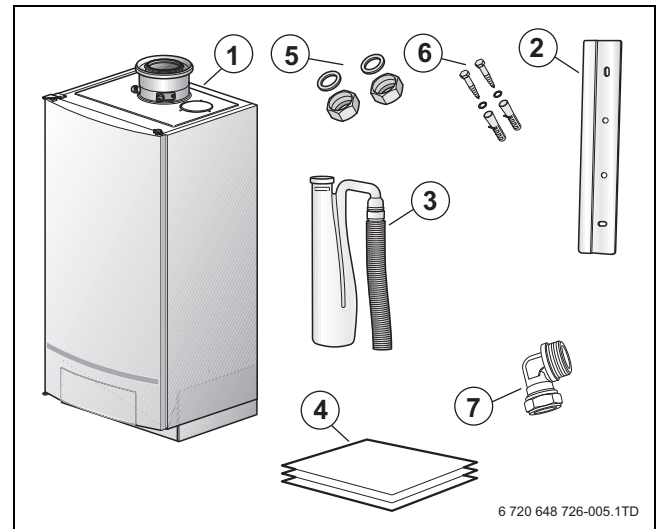

Fig. 5 Items supplied with unit

- [1] Boiler assembly
- [2] Wall bracket
- [3] Condensate trap with condensate trap hose
- [4] Technical documents set
- [5] Flow and return union nuts with sealing rings (2x)
- [6] Screws and plugs for wall bracket (2x)
- [7] Compression elbow for pressure relief valve in pump group

## 7 Dimensions of boiler

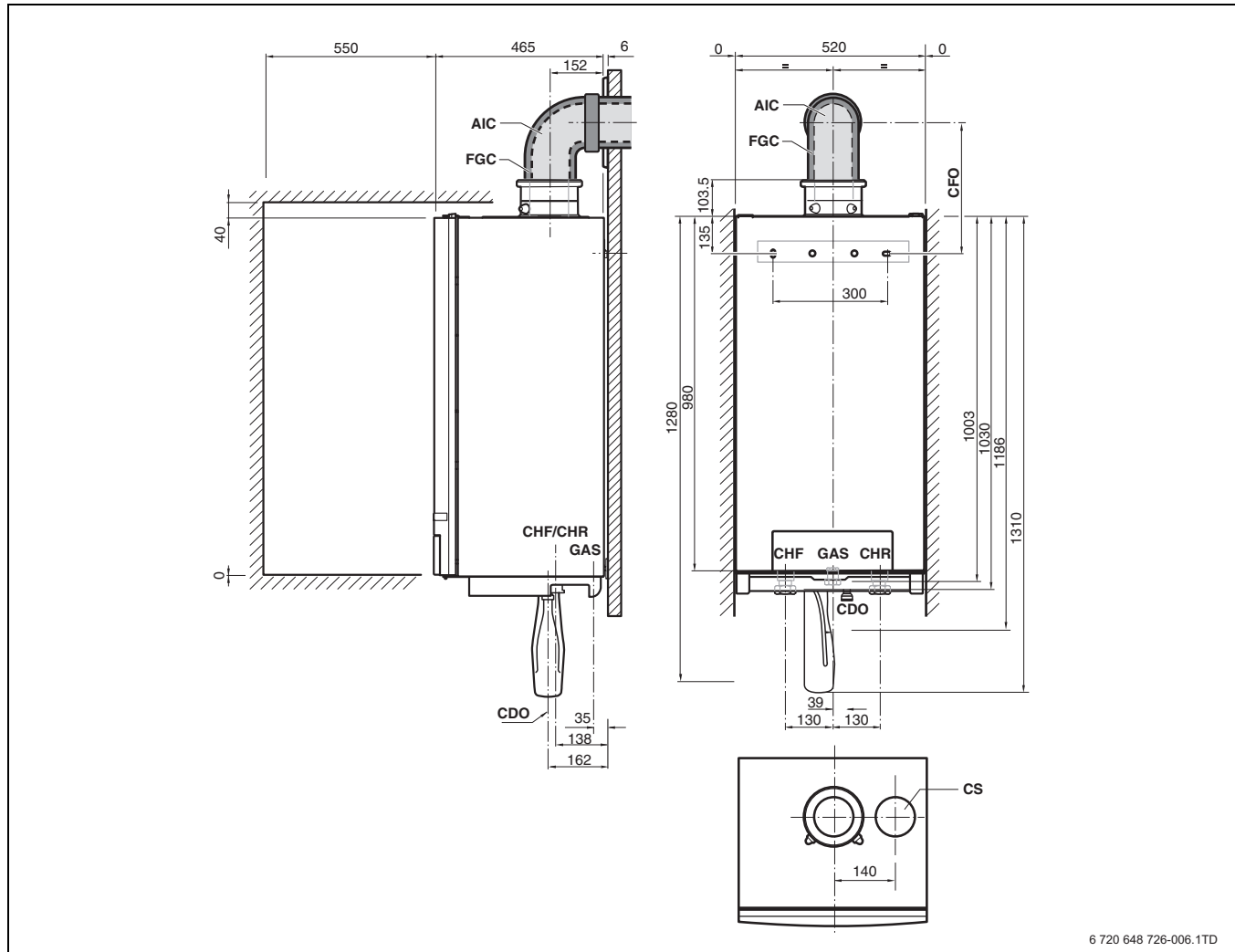

Fig. 6 Dimensions and connections WITHOUT pump group (dimensions in mm)

- [CDO] Condensate drain outlet; Ø 24 mm O/D
- [CFO] Distance from wall bracket to centre of horizontal flue elbow; 337.5 mm for Ø 80/125 flue and 339.5 mm for Ø 100/150 flue
- [CHF] CH (boiler) flow; G1½" union nut with female thread
- [CHR] CH (boiler) return; G1½" union nut with female thread
- [CS] Cap (DO NOT remove)
- [FGC/AIC] Flue gas/air intake connection: Ø 80/125 for GB162-50/65 and Ø 100/150 for GB162-80/100
- [GAS] Gas connection to boiler; G1" female thread

The servicing clearances required are:

- in front: 50 mm
- below: 0 mm (250 mm with pump group)
- right side: 0 mm
- left side: 0 mm
- above: 30 mm.

The position selected for installation **must** allow adequate space for servicing in front of the boiler:

- in front: 550 mm
- below: 350 mm
- right side: 0 mm
- left side: 0 mm
- above: 40 mm.

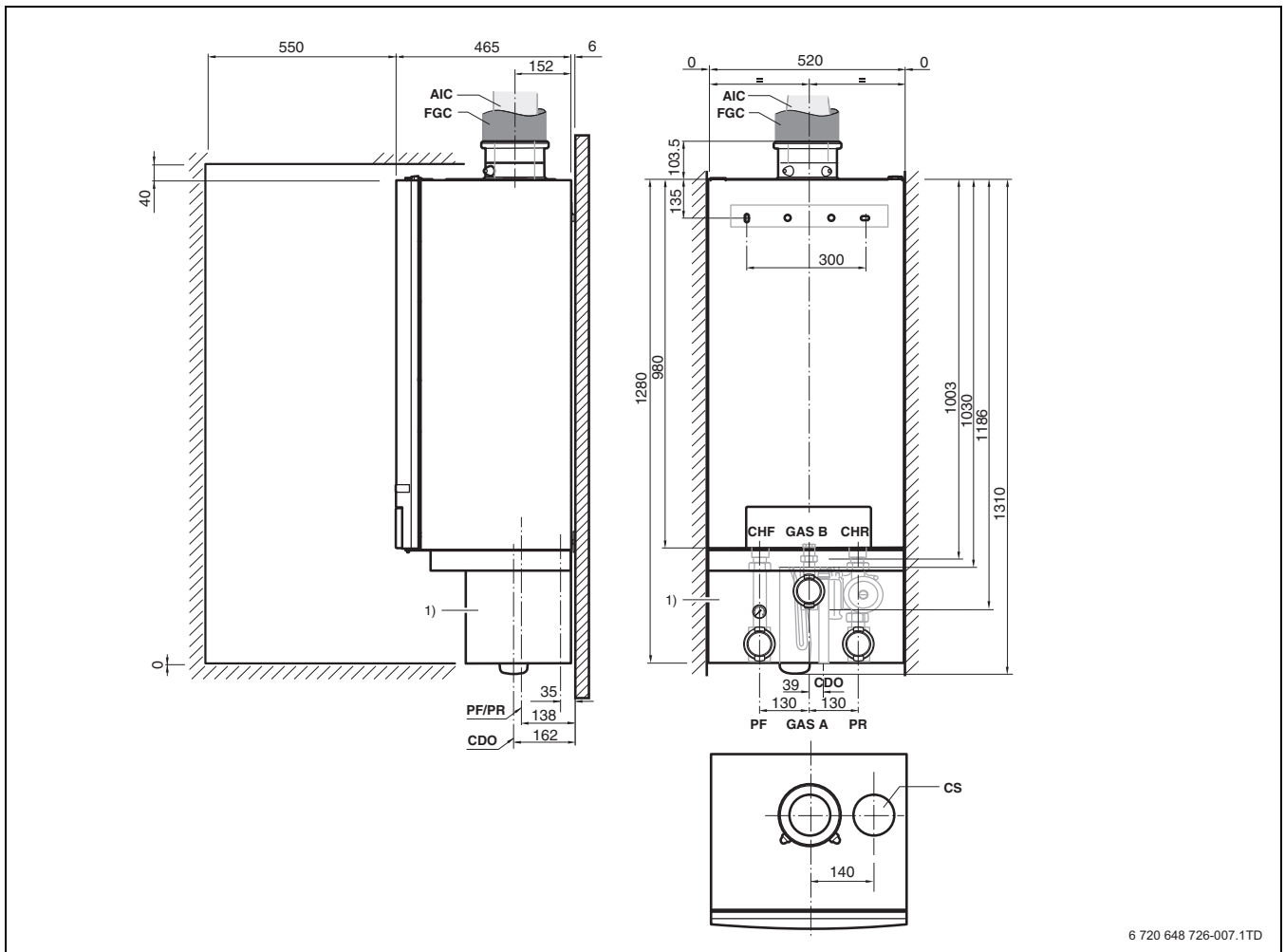

6 720 648 726-007.1TD

Fig. 7 Dimensions and connections **with** pump group (dimensions in mm)

1) The pump group is an accessory which has to be ordered separately.

- [CDO] Condensate drain outlet; Ø 24 mm O/D
- [CHF] CH (boiler) flow; G1½" union nut with female thread
- [CHR] CH (boiler) return; G1½" union nut with female thread
- [CS] Cap (DO NOT remove)
- [FGC/AIC] Flue gas/air intake connection: Ø 80/125 for GB162-50/65 and Ø 100/150 for GB162-80/100
- [GAS B] Gas connection to boiler; G1" female thread
- [GAS P] Gas connection to pump group; Rp1" female thread
- [PF] Pump group flow; G1½" male thread, flat seal
- [PR] Pump group return; G1½" male thread, flat seal

The servicing clearances required are:

- in front: 50 mm
- below: 0 mm (250 mm with pump group)
- right side: 0 mm
- left side: 0 mm
- above: 30 mm.

The position selected for installation MUST allow adequate space for servicing in front of the boiler:

- in front: 550 mm
- below: 350 mm
- right side: 0 mm
- left side: 0 mm
- above: 40 mm.

## 8 Installation

This section explains how to install the boiler in a professional manner.

### 8.1 Installing the boiler

Observe the installation distances of the concentric flue gas system in the separate flue gas system manual.

- ▶ Before starting installation check that the carrying capacity of the wall is sufficient for the boiler weight.



**CAUTION:** Damage to the installation.

- ▶ Do not remove the polystyrene foam bottom slab, otherwise the connection injectors might be damaged.
- ▶ Do not lift the boiler by holding it by the door over the BC10 (→ section 5.1).
- ▶ During installation work, cover the boiler and the flue gas adapter to prevent site dirt from entering.

- ▶ Remove the packaging and dispose of it in an environmentally manner.
- ▶ Measure the installation height (→ chapter 7 “Dimensions of boiler”, page 12).
- ▶ Mark out both holes using the wall bracket (step 1) using a spirit level.
- ▶ Drill 2 holes in the wall (step 2).
- ▶ Insert the 2 enclosed plugs in the drilled holes (step 3).
- ▶ Install the wall bracket, using the 2 enclosed screws (step 4).

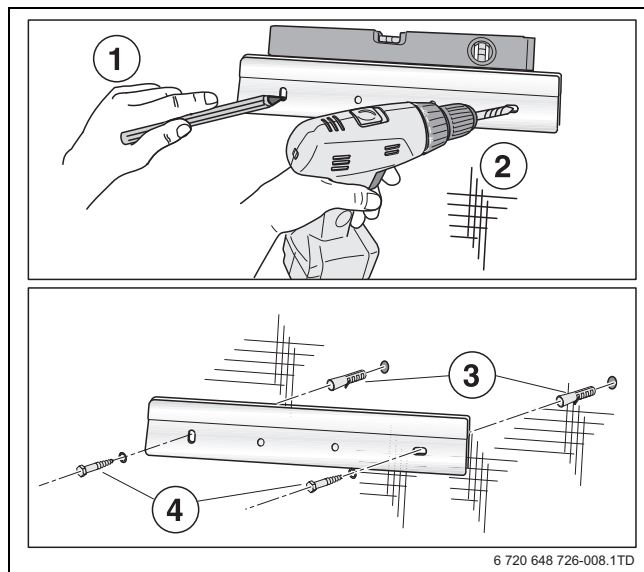

Fig. 8 Installing the wall bracket

- ▶ With 2 people, lift the boiler by holding it by its back and by the transport rail at its bottom and install it on the wall bracket (→ fig. 3, page 11).

- ▶ Slide the boiler into place (→ fig. 9).

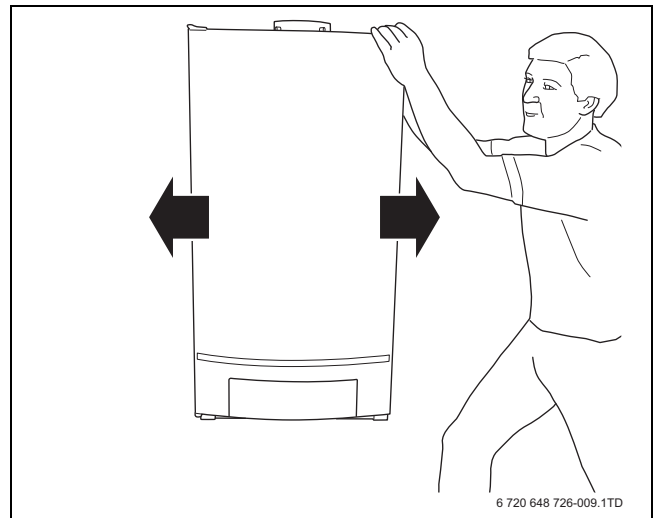

Fig. 9 Sliding the boiler

- ▶ Level the boiler using the set screw and a spirit level (→ fig. 10).

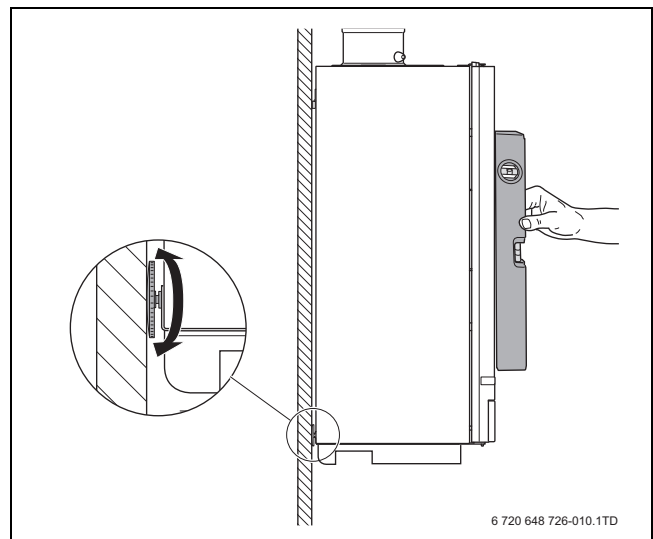

Fig. 10 Aligning the boiler with the set screw

- ▶ Remove the protective covers from the bottom of the boiler (→ fig. 11).

**i** Some residual water from final testing may leak away.

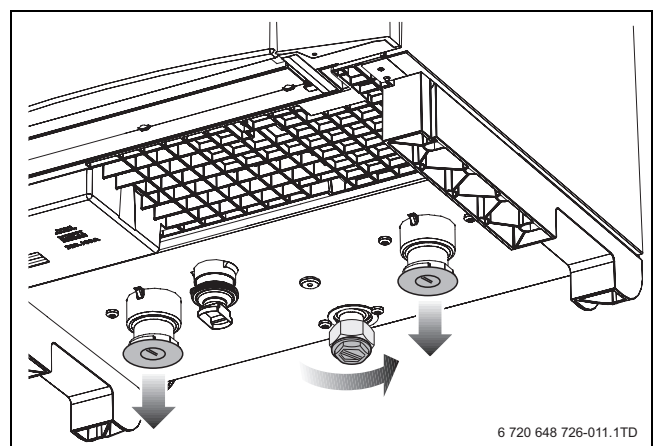

Fig. 11 Removing the covers

## 8.2 General connection of mains water and gas components

### 8.2.1 General

The water and gas connections to the boiler can be made in either of 2 ways:

- using a pump group (→ fig. 12)
- without a pump group.

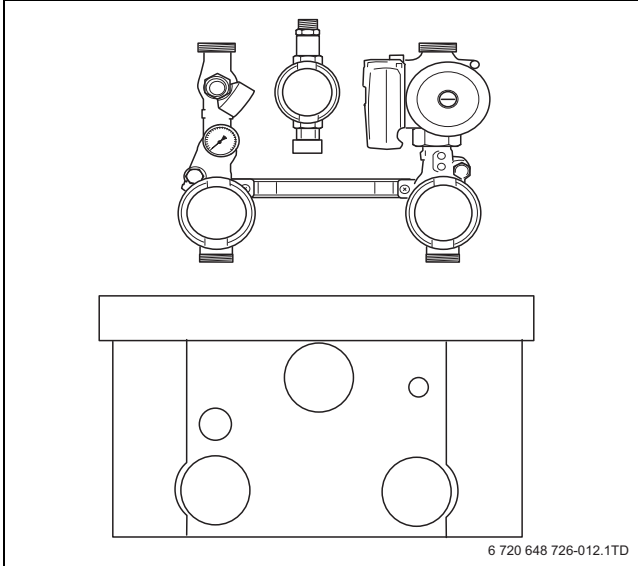

Fig. 12 Pump group (accessory)

The circulation pump is not factory-installed in the boiler. This pump is included in the pump group (accessory).

If you do not make use of a pump group, you have to install a separate circulation pump under the boiler. This pump must be selected so that the volume flow through the boiler is sufficient to handle the maximum boiler capacity.

Correct pump selection see chapter 8.2.8 "Selecting and installing the pump", page 16.

The pump group has been developed specifically for this boiler and has already been fitted with the correct pump.

The pump group also includes various fittings, such as service fittings, a pressure relief valve, a pressure gauge, a gas valve etc. This makes installing the appliance easier to overcome resistance in the heating circuit.

Both installation methods are described below.

- ▶ Decide whether you would like to connect the heating device with or without a pump group. If you don't use our pump group, you have to calculate a separate pump. Make sure, that the pump is large enough, for the flow to overcome resistance in the heating circuit.

### 8.2.2 Install the water and gas connections to the boiler using a pump group (accessory)

The central heating system should be installed in accordance with BS 6798 and, in addition, for small bore and micro bore systems, BS 5449 or EN 12823.

The gas installation must be installed in accordance with BS 6891.

- ▶ Install the pump group on the boiler in accordance with the enclosed installation instructions.

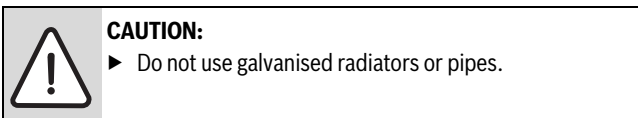

### 8.2.3 Install the water and gas connections to the boiler without a pump group

- ▶ Connect all pipes making sure that they are not bent or twisted to cause any stress.

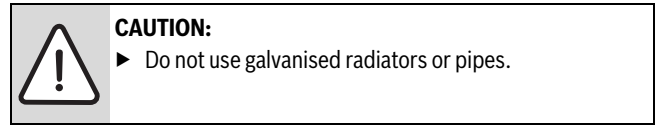

- ▶ Make sure that the connections are tight and carry out a gas and water leakage test after completing the connection work.

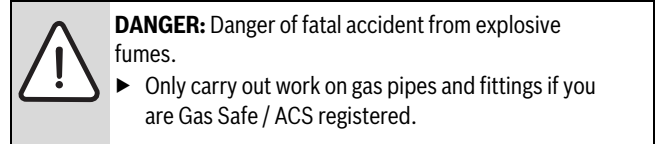

#### Installing the gas connection

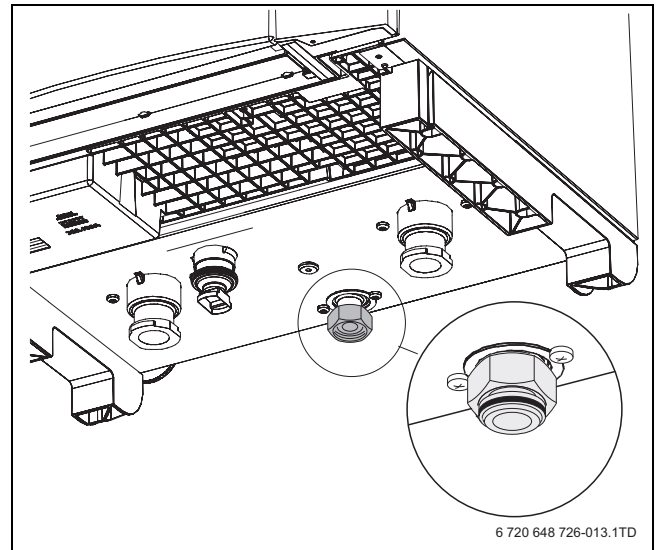
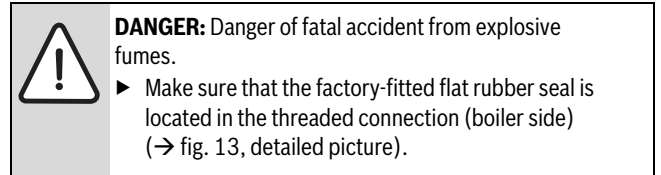
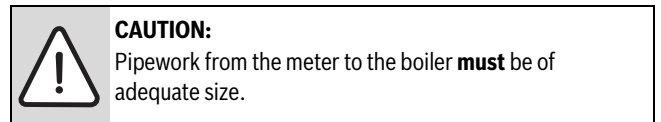
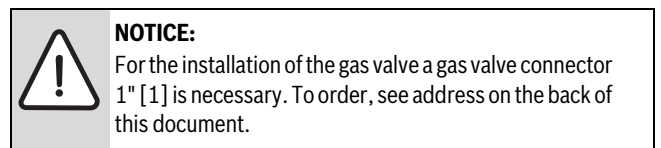

Fig. 13 Rubber seal

The gas installation must be installed in accordance with BS 6891.



The complete installation **must** be tested for gas leakage and purged as described in IGE/UP/1b.



## Installation

- ▶ Install the gas valve connector 1" [1] (accessory).
- ▶ Install the gas valve [2] onto the gas pipe. Use a gas valve with a minimum diameter of 1".

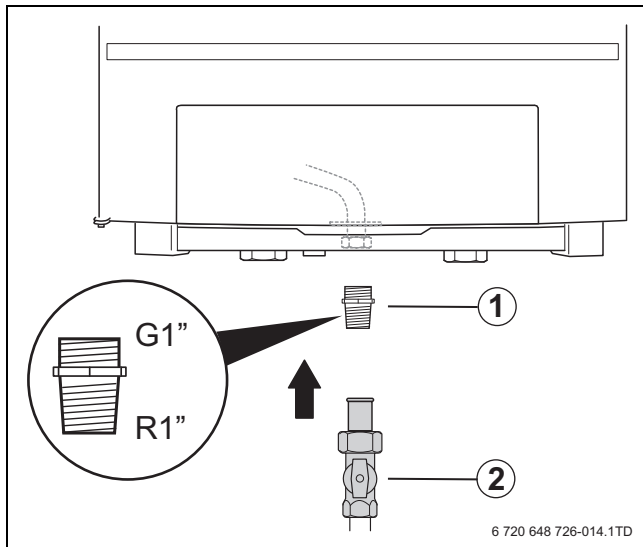

Fig. 14 Making the gas connection

- [1] Gas valve connector 1"
- [2] Gas valve 1"

- ▶ Connect the main gas pipe to the gas connection making sure it is not under stress. Use a gas pipe of at least  $\varnothing 22$  mm.
- ▶ Make the gas connection according to the country-specific standards and regulations.
- ▶ Carry out gas leak test on gas connection using leak detection spray and purged as described in IGE/UP/1b.

### Installing the heating flow and return pipe

The central heating system should be installed in accordance with BS 6798 and, in addition, for small bore and micro bore systems, BS 5449 or EN 12823.



When using plastic pipes, observe the supplier's instructions - especially those referring to recommended jointing techniques and the notes relating to the heating system water on page 6



#### NOTICE:

To prevent contamination in the heating system we recommend you to integrate a dirt filter [10] in the return pipe, near the boiler. In an old system it is a requirement to install a dirt filter.

- ▶ Install shut-off valves to enable filter cleaning immediately upstream and downstream of the dirt filter.

- ▶ Connect the flow pipe with a flat rubber seal installed to the CHF (CH boiler flow) connection [1] making sure it is not under stress. Use a flow pipe with a minimum diameter of 1½".
- ▶ Connect the return pipe with a flat rubber seal installed to the CHR (CH boiler return) connection [2] making sure it is not under stress. Use a return pipe with a minimum diameter of 1½".

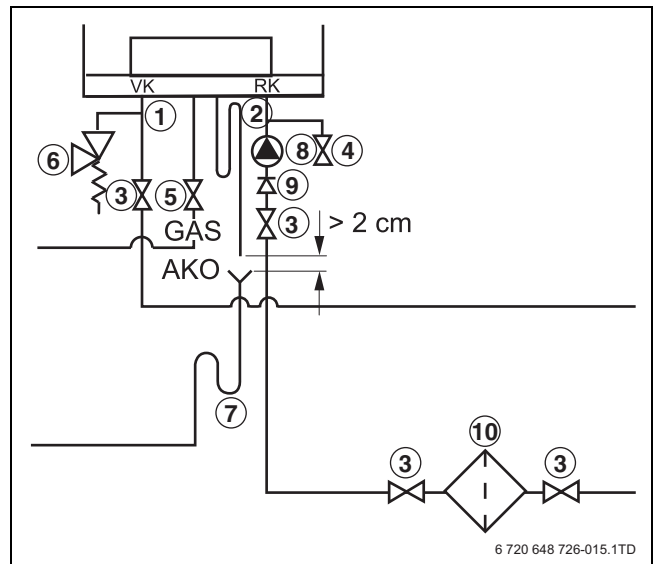

Fig. 15 Connecting the boiler flow and return

- [1] CH boiler flow
- [2] CH boiler return
- [3] Isolating valves
- [4] Drain cock
- [5] Gas valve
- [6] Pressure relief valve
- [7] Condensate trap
- [8] Pump
- [9] Non-return valve
- [10] Dirt filter

### 8.2.4 Installing the differential pressure controller

In situations where there is no low loss header, installing a bypass with a differential pressure controller would not be required.

If a low loss header is present, it may be required -depending on the situation - to install a bypass with a differential pressure controller to the secondary side of the low loss header. This serves to protect the secondary pump against overheating as a result of insufficient flow.

### 8.2.5 Installing the isolating valves

- ▶ Install a isolating valve for maintenance and repair purposes in both the boiler flow and return circuits (→ fig. 15, [3]). Use isolating valves with a minimum diameter of 1½".

### 8.2.6 Installing the drain cock

- ▶ Connect a drain cock in the return circuit (→ fig. 15, [4]).

### 8.2.7 Installing a pressure relief valve



#### CAUTION: Damage to the installation.

The pressure in the heating system can become excessively high.

- ▶ Install a pressure relief valve.

- ▶ Install a 4-bar pressure relief valve (→ fig. 15, [6]) with a minimum passage of 22 mm in the flow circuit. Make sure that the pressure relief valve is always installed between the boiler and the isolating valve, so that the boiler will always be in contact with the pressure relief valve, even if the isolating valves are closed.

### 8.2.8 Selecting and installing the pump

- ▶ Select a pump according to the hydraulic boiler resistance specified in table 5 or in the curve in fig. 122 on page 62.
- ▶ When using the curve take the nominal required volume flow into consideration according to table 3.
- ▶ When selecting the pump, take the maximum volume flow of the boiler according to table 4 into consideration.



Select a pump with a residual head of at least 200 mbar at the minimum required volume flow (→ table 4).

GB162-50	GB162-65	GB162-80	GB162-100
2,200	3,000	3,600	4,300

Table 3 Nominal required volume flow [l/h] at  $\Delta T = 20 K$

GB162-50	GB162-65	GB162-80	GB162-100
5,000	5,000	5,000	5,000

Table 4 Maximum volume flow [l/h] at  $\Delta T = 20 K$

GB162-50	GB162-65	GB162-80	GB162-100
90	170	225	320

Table 5 Resistance over the boiler at the nominal required volume flow [mbar]

- ▶ Install the pump (→ fig. 15, [8]) in the return circuit (→ fig. 15, [2]).

### 8.2.9 Installing the condensate trap



**DANGER:** Danger of fatal accident due to poisoning.

- ▶ If the condensate trap is not filled with water, flue gas can escape and put people's lives at risk.

- ▶ Fill the condensate trap (supplied with the boiler) with water (→ fig. 16).

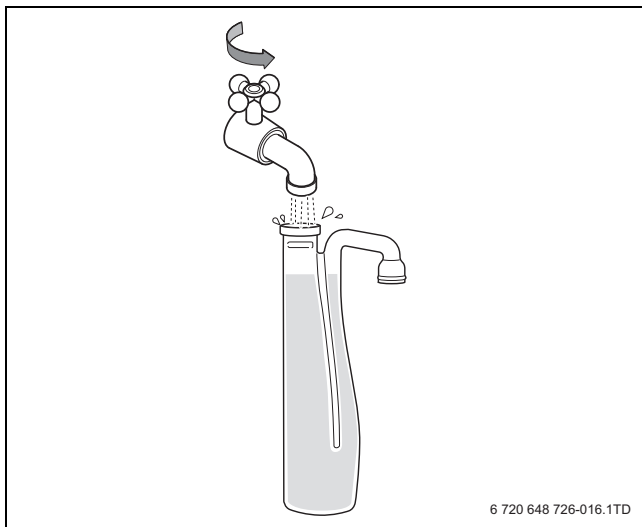

Fig. 16 Filling the condensate trap with water

- ▶ Connect the condensate trap [1] to the condensate drain outlet (CDO).



The trap is fitted with a bayonet connection. After pushing [step 1] the trap upwards into place, you have to turn it a ¼ turn anticlockwise [step 2] until it locks into position.

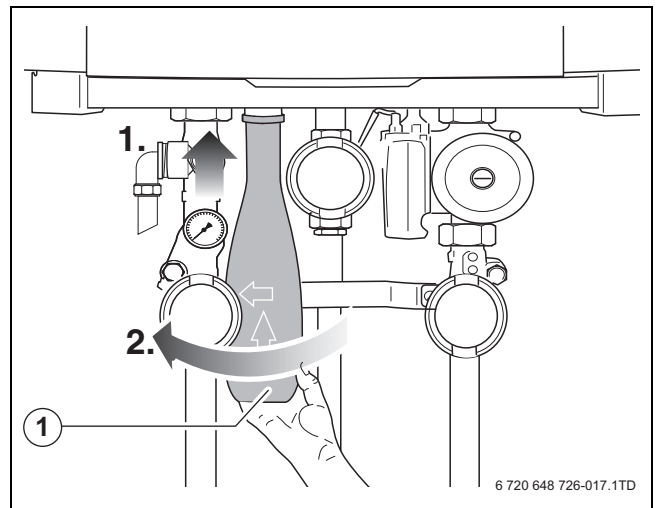

Fig. 17 Installing the condensate trap

- [1] Condensate trap
- ▶ Connect the condensate trap hose [3] and the rubber sleeve [2] to the condensate trap [1].

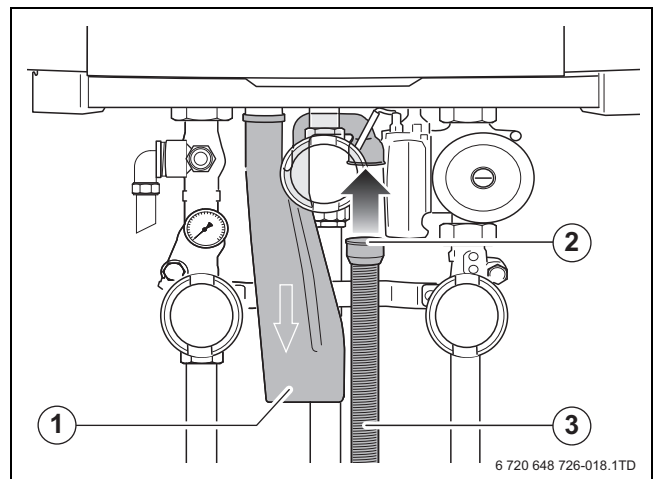

Fig. 18 Installing the condensate trap hose

- [1] Condensate trap
- [2] Rubber sleeve
- [3] Condensate trap hose

### 8.2.10 Condensate removal

#### Positioning and termination of the condensate drain pipe

The condensate pipe should run and connected to the internal sewage pipe in the house or waste pipe. Alternatively, the condensate can be discharged into the rainwater system if connected to a foul water draining system, or into a purpose-made soak away (condensate absorption point).

All connecting drainage pipework should generally have a fall of at least 2.5° to the horizontal, or approximately 50 mm per metre of pipe run. If this is can-not be achieved, consider the use of a sewage pump.



**WARNING:**

Any external run must be insulated with water proof insulation.

It should be noted that the connection of a condensate pipe to a drain may be subject to local building controls.

**Material for condensate**



Ensure that the condensate trap is filled with water.

The condensate drainage pipe should be run in a standard drain pipe material, e.g. PVC (polyvinyl chloride), PVC-U (unplasticized polyvinyl chloride), BS (acrylonitrile-butadienestyrene), PP (polypropylene polypropylene) or PVC-C (cross-linked polyvinyl chloride).

Any internal pipework should be of a diameter to match the requirements of the condensate exit pipe on the appliance.

**Termination to internal pipe**

The condensate drain pipe should have a minimum outside diameter of Ø21.5 mm with no length restriction. It should incorporate a trap with a 75 mm condensate seal and be connected to the stack at a point at least 450 mm above the invert of the stack. The trap built into the boiler will provide this 75 mm (→ fig. 19) condensate seal.

The minimum distance between the condensate trap and the condensate drain pipe is 2 cm. An air gap should be maintained between the boiler condensate trap and the condensate pipework.

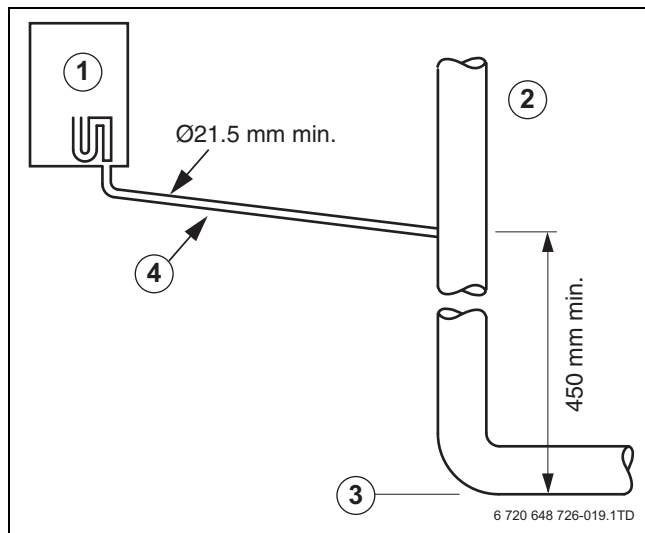

Fig. 19 Termination of condensate drain pipe to internal pipe

- [1] Boiler
- [2] Internal soil and vent pipe
- [3] Invert
- [4] No length restriction

**External termination via internal branch (e.g. sink waste)**

The condensate drain pipe should have a minimum outside diameter of Ø21.5 mm with no length restriction. The connection should preferably be made downstream of the sink waste trap. If the connection is only possible upstream, then an air break is needed between the 2traps. This is normally provided by the sink waste pipe (→ fig. 20 and 21).

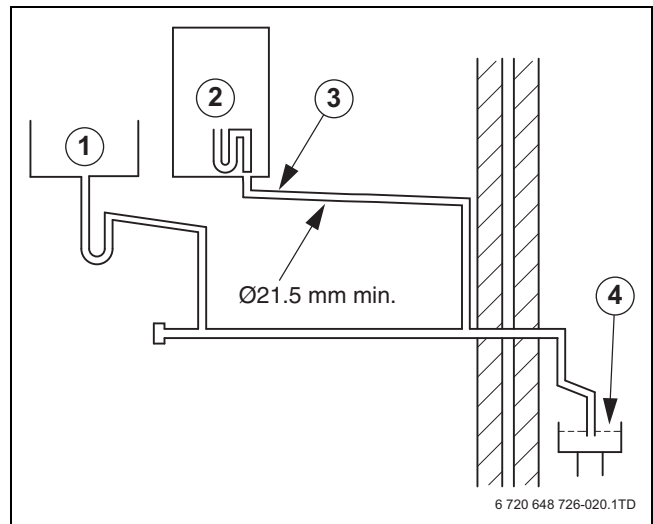

Fig. 20 Internal termination of condensate drain pipe to external waste point

- [1] Sink
- [2] Boiler
- [3] No length restriction
- [4] Open end of pipe direct into drain, below ground but above water level

An air gap should be maintained between the boiler condensate trap and the condensate pipework.

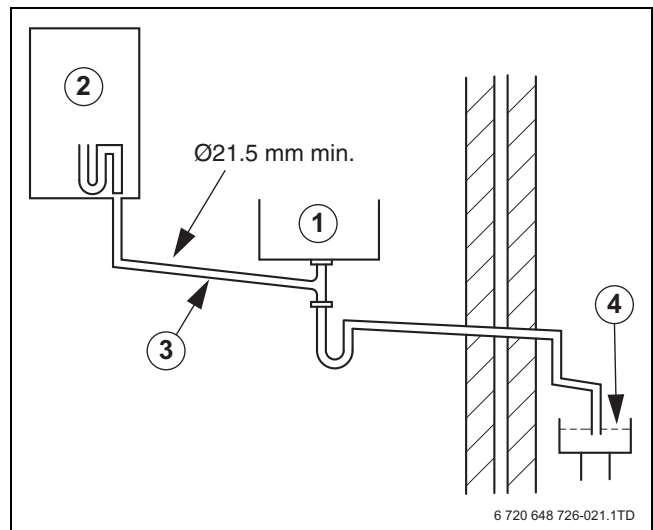

Fig. 21 External termination of condensate drain pipe via internal discharge branch (e.g. sink waste – proprietary fitting) and condensate trap

- [1] Sink
- [2] Boiler
- [3] No length restriction
- [4] Open end of pipe direct into drain, below ground but above water level

**Condensate absorption point**

The condensate drain pipe should have a minimum outside diameter of Ø21.5 mm and the external pipe length should not be more than 3 m. The condensate absorption point should be sited in a convenient position as close as possible to the boiler but not in the vicinity of other services. See fig. 22 for information.



When discharging condensate to an outside drain caution must be taken to ensure blockage cannot occur during freezing conditions. If this is likely to occur, the use of a condensate trap is recommended.

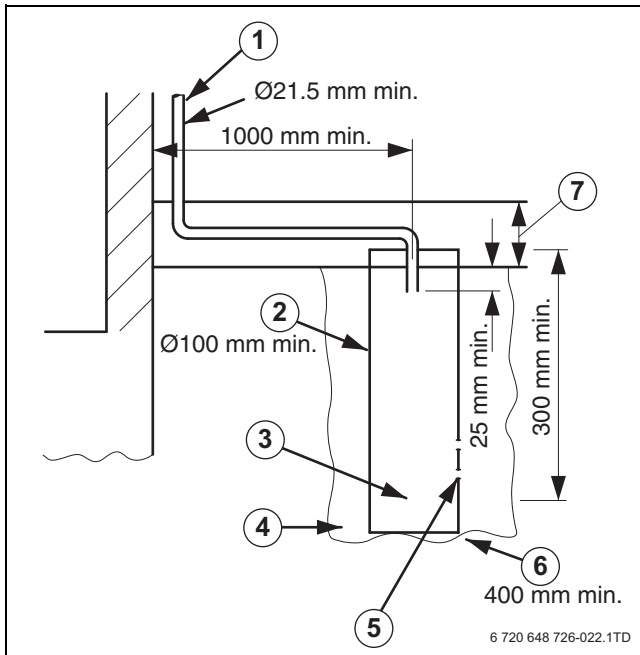

Fig. 22 External termination of condensate drain pipe to absorption point

- [1] External length of pipe 3 m max.
- [2] Plastic tube
- [3] Bottom of tube sealed
- [4] Limestone chippings
- [5] Two rows of three 12 mm holes at 25 mm centres, 50 mm from bottom of tube and facing away from house
- [6] Hole depth
- [7] Ground (either/or)

### 8.2.11 Connecting the condensate drain pipe

► Connect the condensate drain pipe to the condensate trap (→ fig. 23, [1] and fig. 24, [1]).

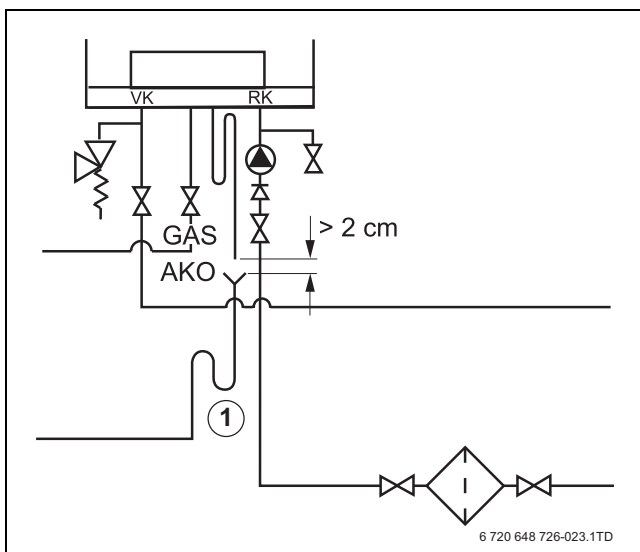

Fig. 23 Connecting the condensate trap

- [1] Condensate trap

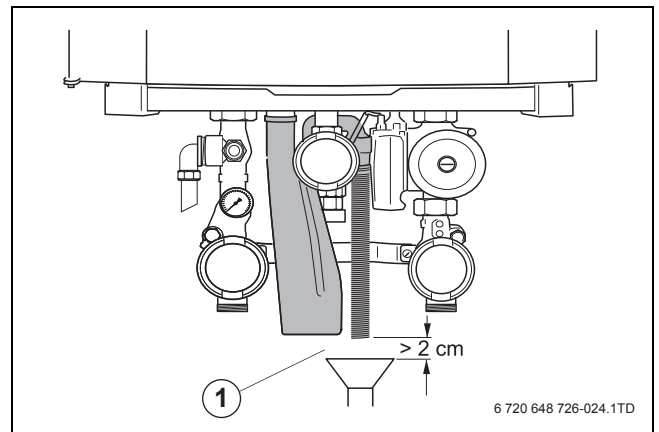

Fig. 24 Condensate drainage pipe

- [1] Minimum distance > 2 cm

Observe the following regulations:

- The (local) waste water disposal regulations.
- The condensate trap in the connection kit must not be permanently connected to the condensate drain pipe. The minimum distance between the condensate trap and the condensate drain pipe is 2 cm.

An air gap should be maintained between the boiler condensate trap and the condensate pipework.

### 8.2.12 Connecting the expansion vessel in a single-boiler system



**CAUTION:** Damage to the installation due to faulty pressure relief valve.

► The expansion vessel must be of sufficient capacity.

- Connect the expansion tank to the boiler return (CHR). If a non-return valve is available: connect the expansion vessel to the CH-side of the non-return valve in the return circuit (→ fig. 25, [1]).

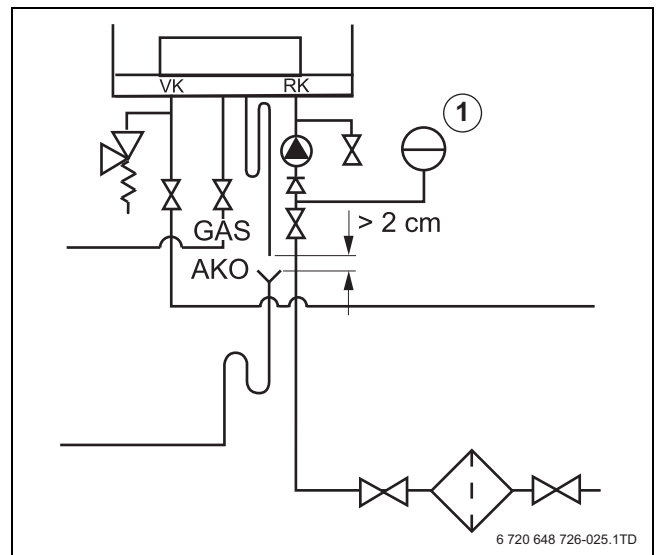

Fig. 25 Connecting the expansion vessel in a single-boiler system

- [1] Expansion vessel

### 8.3 Flue Installation

#### 8.3.1 Siting the flue terminal

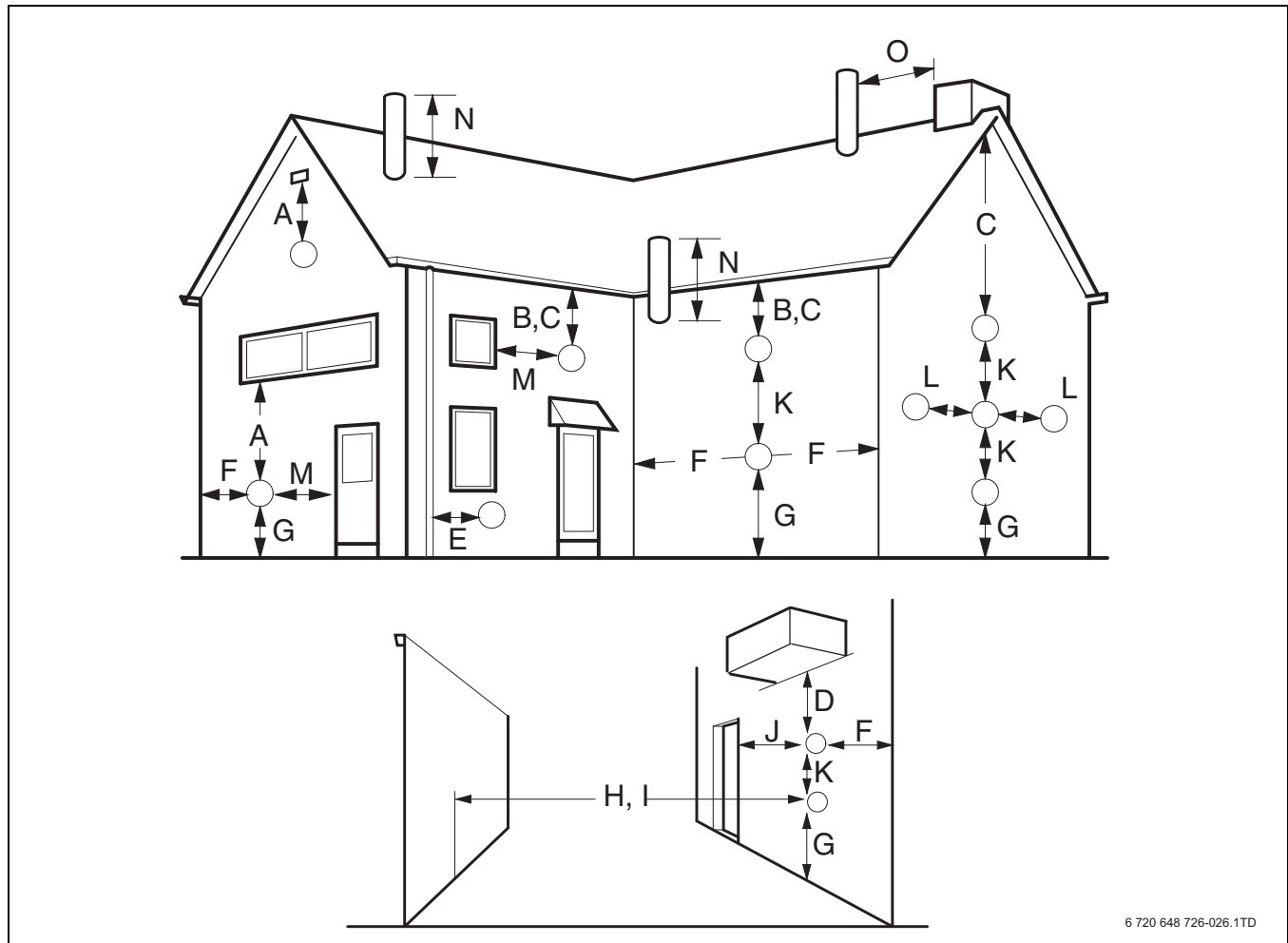

Fig. 26 Balanced flue terminal position

#### Terminal position

- [A] Directly below, above or alongside an opening window, air vent or other ventilation opening
- [B] Below guttering, drain pipes or soil pipes
- [C] Below eaves
- [D] Below balconies or a car port roof Not recommended!
- [E] From vertical drain pipes or soil pipes
- [F] From internal or external corners
- [G] Above adjacent ground, roof or balcony level
- [H] From a surface facing the terminal
- [I] From a terminal facing a terminal
- [J] From an opening in a car port (e.g. door or window) into dwelling. Not recommended!
- [K] Vertically from a terminal on the same wall
- [L] Horizontally from a terminal on the wall
- [M] Adjacent to opening
- [N] Above intersection with roof
- [O] From a vertical structure on the roof

#### Minimum spacing [mm]:

- 300
- 200
- 200
- 200
- 150
- 300
- 300
- 600
- 1200
- 1200
- 1500
- 300
- 300
- 300
- 500

The flue for installations in excess of 70 kW must be installed in accordance with the recommendations of IGE UP10.

Plumbing will occur at the terminal so terminal positions where this could cause a nuisance should be avoided.

The air supply and the flue gas exhaust must meet the applicable general regulations. Please consult the instructions provided with the flue terminal kits prior to installation.

The boiler **must** be installed so that the terminal is exposed to external air.

It is important that the position of the terminal allows the free passage of air at all times.

Minimum acceptable spacing from the terminal to obstructions and ventilation openings are specified in fig. 26.

If the lowest part of the terminal is less than 2 metres above the level of the ground, balcony, flat roof or place to which any person has access, the terminal must be protected by a guard.

Ensure that the guard is fitted centrally.

The flue assembly shall be so placed or shielded as to prevent ignition or damage to any part of the building.

The flue outlet duct and the terminal of the boiler **must not** be closer than 25 mm to combustible material. Detailed recommendations on the protection of combustible material are given in IGE UP10.



It is very important to ensure, that products of combustion discharging from the terminal cannot re-enter the building or any other adjacent building. Through ventilators, windows, doors, other sources of natural air infiltration, or forced ventilation/air-conditioning.

If this could occur the appliance **must** be turned off, and labelled as unsafe until corrective action can be taken.



**DANGER:**

► Only use Worcester flue gas systems. As other flue gas systems are not tested with this appliance.

**8.3.2 Air supply and flue gas exhaust in a room sealed installation**

A ventilation cover is integrated into the condensing gas system boilers. This cover houses a number of components, such as the burner and the heat exchanger. Since this ventilation cover is part of the air supply system, it is vital that it is always installed correctly.

To ensure optimal operation, the appliances must be connected to a Worcester horizontal or vertical flue terminal. These terminals have been developed specifically for Worcester condensing gas boilers and have been comprehensively tested for trouble free operation when correctly installed.

Standard horizontal flue pack (→ fig. 27) for GB162-80/100:

- 1: Flue turret 100/150;
- 2: Horizontal flue terminal 100/150;
- 3: Flue finishing kit.

Standard horizontal flue pack (→ fig. 27) for GB162-50/65:

- 1: Flue turret 80/125;
- 2: Horizontal flue terminal 80/125;
- 3: Flue finishing kit.

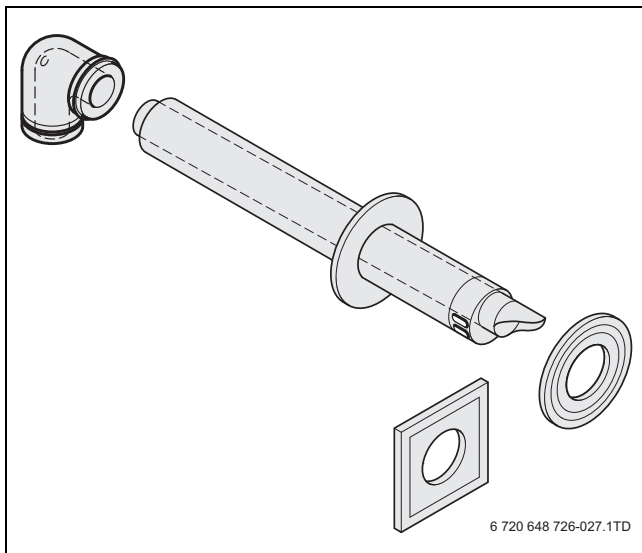

Fig. 27 Standard horizontal flue pack

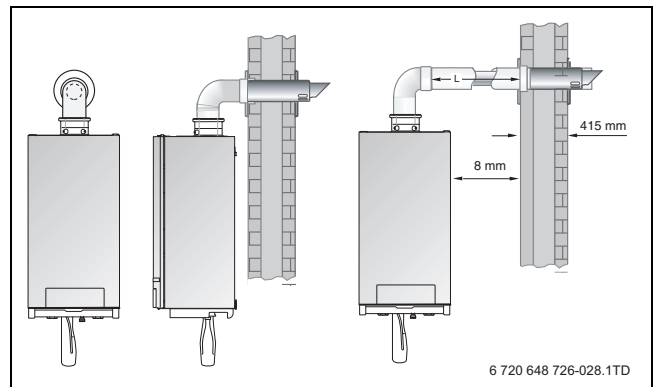

Fig. 28 Side flue and rear flue installation

Standard vertical flue pack (→ fig. 29) for GB162-80/100:

- Concentric vertical flue pipe 100/150;
- Wall clamp.

Standard vertical flue pack (→ fig. 29) for GB162-50/65:

- Concentric vertical flue pipe 80/125;
- Wall clamp.

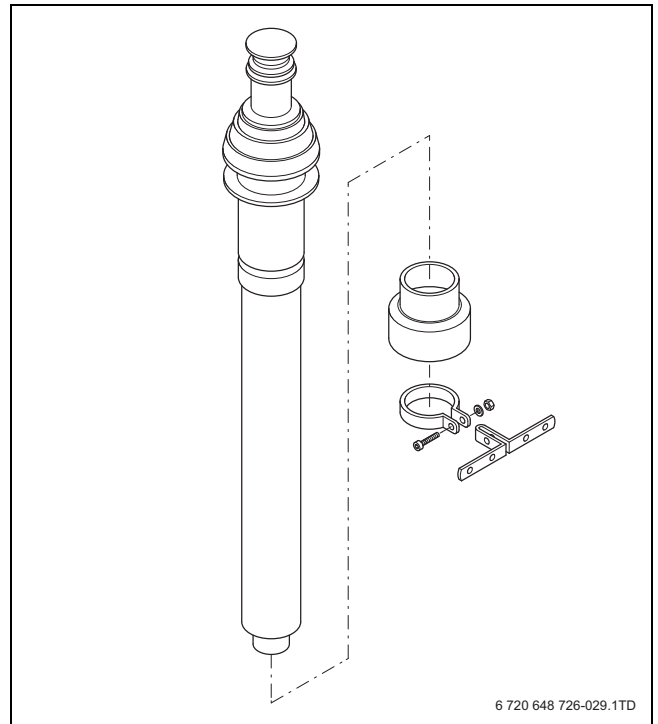

Fig. 29 Standard vertical flue pack

### 8.3.3 Maximum Flue length (L)

The maximum pipe length (L) of the air supply and flue gas exhaust pipes for the condensing gas system boilers is determined by the total pressure loss of all components in the flue system.

Maximum length of horizontal or vertical extensions for 100/150 flue system (→ fig. 30 and fig. 31). For flue length see table 6.

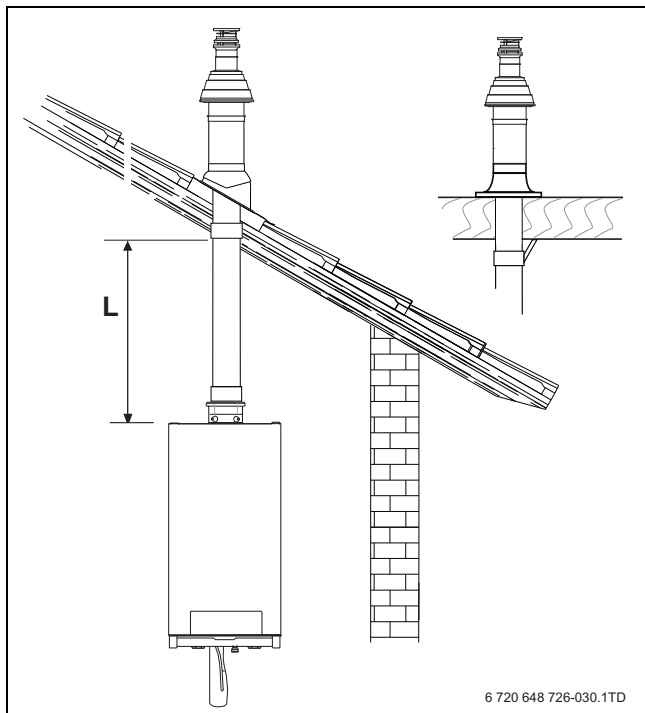

Fig. 30 Vertical flue length

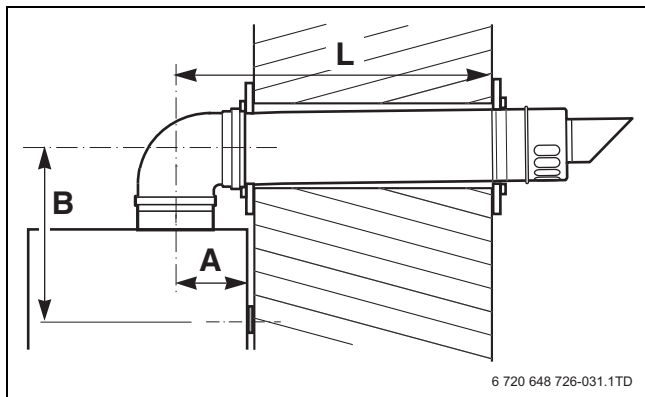

Fig. 31 Horizontal flue length

- [A] Distance from centre of flue to inside rear wall
- [B] Distance from centre wall bracket to centre of flue elbow
- [L] Distance from centre of flue to outside wall

Take the flue pipe clearances into account when planning the layout of the place of installation (→ subsection 8.3.1: “Siting the flue terminal” on page 20).

Maximum wall thickness without extensions is 415 mm. Maintain a minimum side clearance of 8 mm (→ fig. 28).

### 8.3.4 Additional flue parts

The additional flue parts listed can be ordered from your supplier.

#### Flue size 100/150 and 80/125

GB162	Maximum flue length [m] concentric flue system	
	100/150	80/125
50	20	7,7
65	20	7,7
80	18	-
100	18	-

Table 6 Max. flue lengths, incl. wall/roofterminal in meters

GB162	Reduced flue length [m] <sup>1)</sup>							
	concentric flue system 100/150				concentric flue system 80/125			
	bend		extension		bend		extension	
	45°	90°	0.5m	1m	45°	90°	0.5m	1m
50	1.2	2.1	0.5	1.0	0.9	1.9	0.5	1.0
65	1.2	2.1	0.5	1.0	0.9	1.9	0.5	1.0
80	1.2	2.1	0.5	1.0	0.9	1.9	0.5	1.0
100	1.2	2.1	0.5	1.0	0.9	1.9	0.5	1.0

Table 7 Reduced flue lengths in meters

1) For every bend or extension the max. flue length (L) has to be reduced.



The total reduction length must never exceed the maximum flue length.

#### Weathering slates for 100/150 and 80/125

Flat roof, pitched roof.

#### 8.3.5 Standard 100 mm flue systems

The standard concentric flue system provides for a max. horizontal straight length (→ table 6, subsection 8.3.4). Full instructions for fitting this flue are in subsection 8.3.6: “Installation of the horizontal flue” on page 23.



**Important:** Any horizontal flue system fitted to a condensing boiler must be inclined towards the appliance at an angle of 52 mm per metre length to prevent condensate dripping from the flue terminal. This means that the clearance above the appliance must be increased to match the duct length. See fig. 6 on page 12.

### 8.3.6 Installation of the horizontal flue

The standard flue is suitable for lengths up to 660 mm (→ fig. 32). For longer flue runs up to 29.0 m for flue system 100/150 and 7.3 m for flue system 80/125, flue extensions are available (accessory).

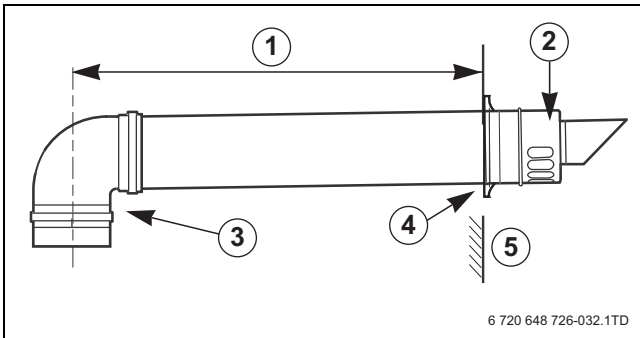

Fig. 32 Installation with horizontal flue gas terminal

- [1] maximum length
- [2] terminal assembly
- [3] 90° bend
- [4] finishing kit
- [5] outer wall

### 8.3.7 Flue pipe preparation and assembly

- ▶ Measure the flue length L. Refer to figures 33 and 34.

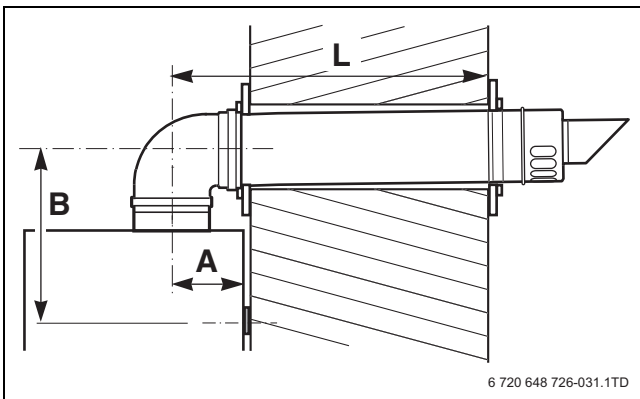

Fig. 33 Flue length - rear

- [A] 150 mm without the use of a wall spacing frame  
185 mm with the use of a wall spacing frame
- [B] 337.5 mm for Ø 80/125 mm horizontal flue  
339.5 mm for Ø 100/150 mm horizontal flue
- [L] flue length

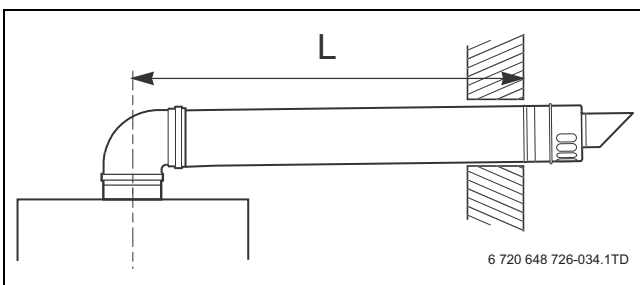

Fig. 34 Flue length - side



The flue must be inclined from the boiler.

- ▶ Mark off the lengths shown onto the pipe and cut to length. The cuts must be square and free from burrs. Terminal assembly outer (air) pipe - L-70 mm, inner (flue) pipe - L-50 mm. The measurement is made from the ridge at the terminal indicating the outer face of the wall. Refer to figure 35. Extension outer flue - L-70 mm, inner flue - L-50 mm. The measurement is from the formed end.

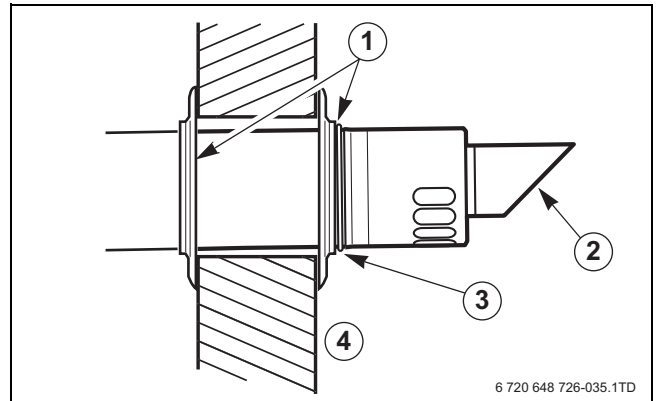

Fig. 35 Flue terminal position

- ▶ Assemble flue system completely. Push the flue fully together. The slope of the terminal outlet must face downwards (→ fig. 35, item 1). The assembly will be made easier if a solvent free grease is lightly applied to the male end of the flue.



An inner flue finishing kit is provided which should be fitted to the ducts before assembly.

- ▶ Push the assembly through the wall and slide the terminal onto the flue connector. Ensure that the terminal is fully entered into the socket on the boiler.
- ▶ From the outside fix the flue finishing kit to the terminal and, after ensuring the flue is properly inclined towards the boiler, fix the finishing kit to the wall. If the terminal is within 2 m of the ground where there is access then an approved terminal guard must be fitted. The guard must give a clearance of at least 50 mm around the terminal and be fixed with corrosion resistant screws.

## 8.4 Flue gas connection

### 8.4.1 Open flue operation

If operation independent of room air is not desired or not possible due to local conditions, the boiler can be set up for operation to take air for combustion from the room (contact Worcester Technical).

The boiler is factory-fitted with a concentric connection.

An air intake strainer basket can be used for operation dependent on room air. This prevents falling dirt from entering the boiler (contact Worcester Technical; accessory).

### 8.4.2 Room sealed operation

The boiler can be connected to a concentric flue gas system.

The boiler is factory-fitted with a concentric connection.

### 8.4.3 Flue material

When using plastic flue material, PPS is recommended.

### 8.4.4 Calculating the air intake and flue gas pipe dimensions

The total reduced pipe length is calculated from the sum of the reduced length of the horizontal and vertical flue ducting and the reduced length of every elbow (→ table 7).

The total reduced pipe length must be less than the maximum pipe length (→ table 6).

See also the next example.

**Example of a flue design calculation for concentric flue system 100/150 using length method**

Boiler: GB162-80

Flue system: concentric 100/150

Maximum length: 18 m.

Here we have:

- 4 meter pipe (2 x 2 m) 4.0 m
- 2 x 90° bends (2 x 2.1 m) 4.2 m

The total length of this flue system = 8.2 m

Sum of length (8.2 m) < maximum length (18 m) → robust flue design!

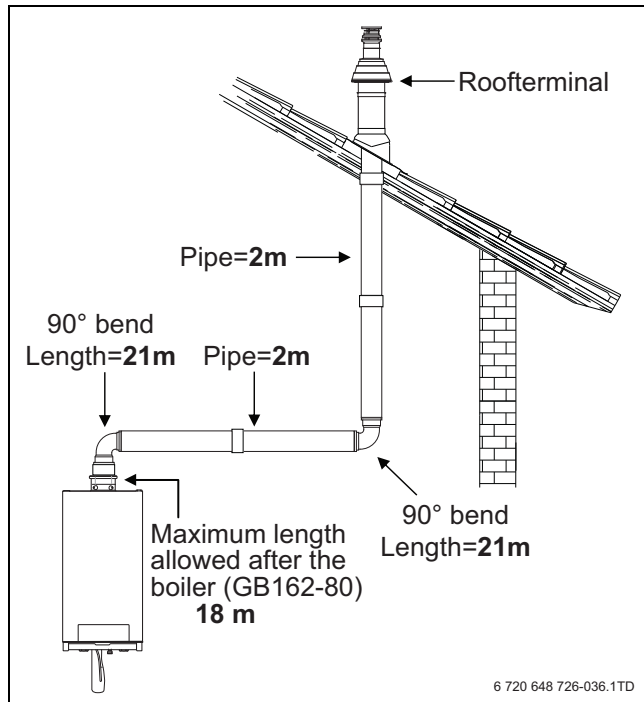

Fig. 36 Example 1

**8.5 Electrical connections**

When connecting the electrical components, observe the wiring diagram, the installation and servicing instructions of the relevant product.



**WARNING:** Damage to the installation due to short circuits.

To prevent electrical components from short-circuiting, only use:

- original cables and wiring supplied by the manufacturer.
- single core cable.

▶ Use cable of at least 0.75 mm<sup>2</sup>.

▶ If the mains lead has to be replaced, you may only use an original manufacturer-supplied mains lead.



**DANGER:** Danger of fatal accident due to electric current when the boiler is open.

▶ Before opening the boiler: Isolate the mains supply.

▶ Secure the heating system so that it cannot be switched on again unexpectedly, pulling the mains plug from the wall socket.



The 230V converter can only be used for the GB162-50/65 appliance.

8.5.1 Electrical wiring diagram

**WARNING:**

⚡ Do **not** directly connect a 230 V thermostat to this boiler. Use the grey 230V connection box (supplied with GB162-50/65).

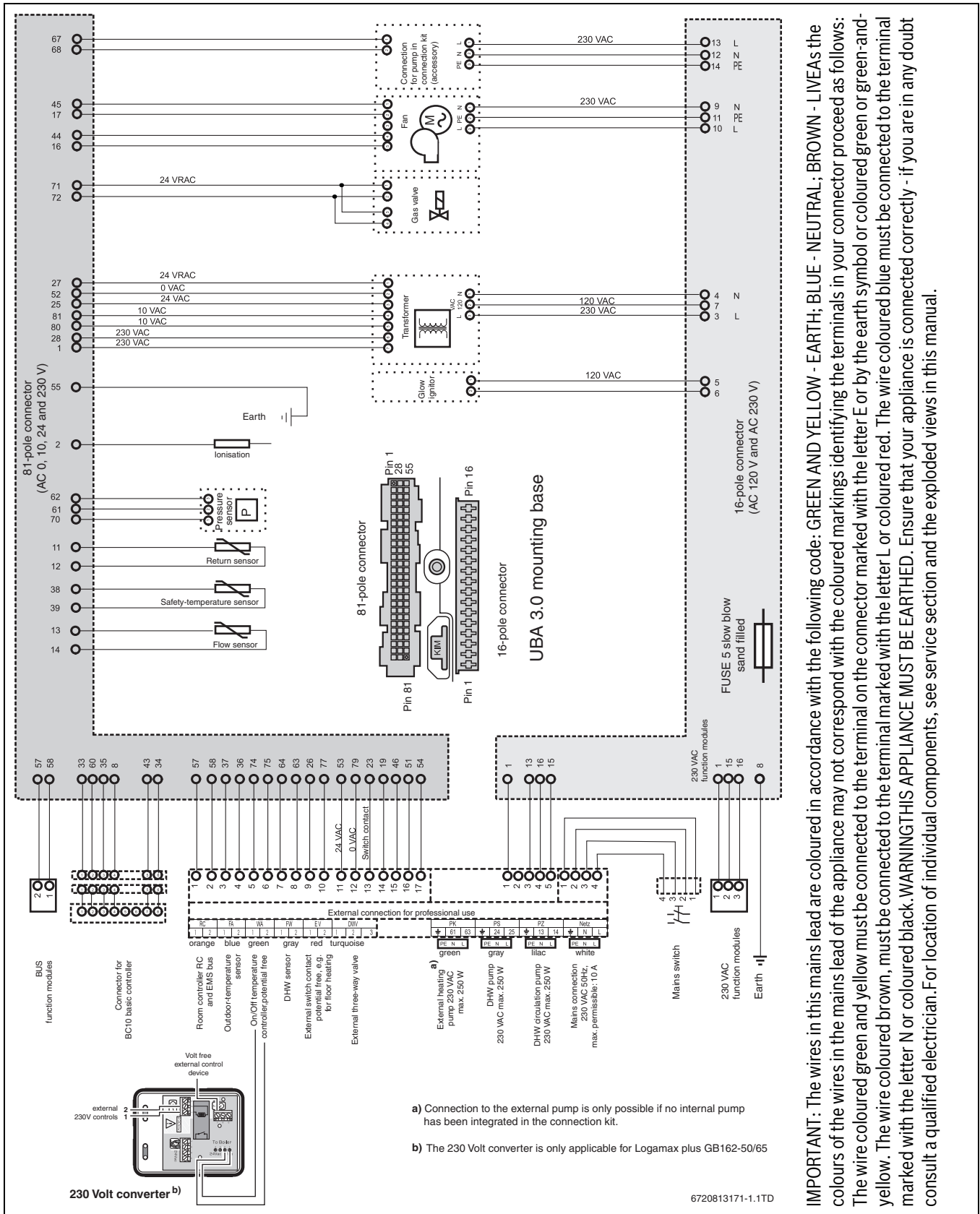

Fig. 37 Electrical wiring diagram

### 8.5.2 Terminal strip connections

- ▶ Turn the vent key through a quarter rotation to undo the boiler door lock (→ fig. 38, see detailed picture).
- ▶ Push the fastener down (→ fig. 38) and open the boiler door.

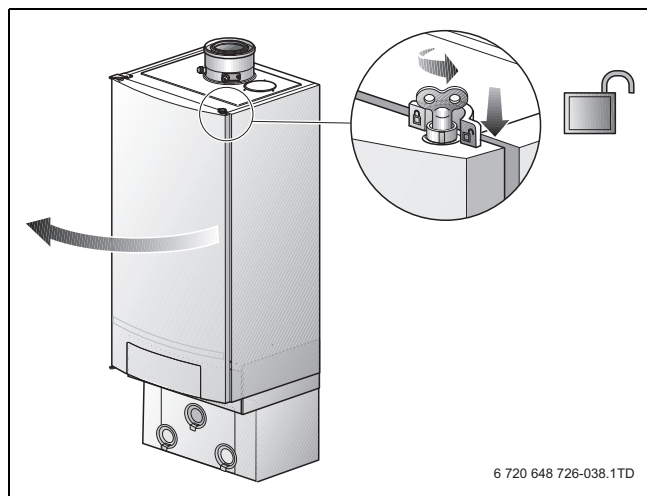

Fig. 38 Open the boiler door

- ▶ Undo 1 screw to release the cover over the electrical connections and pull the cover upwards (→ fig. 39).

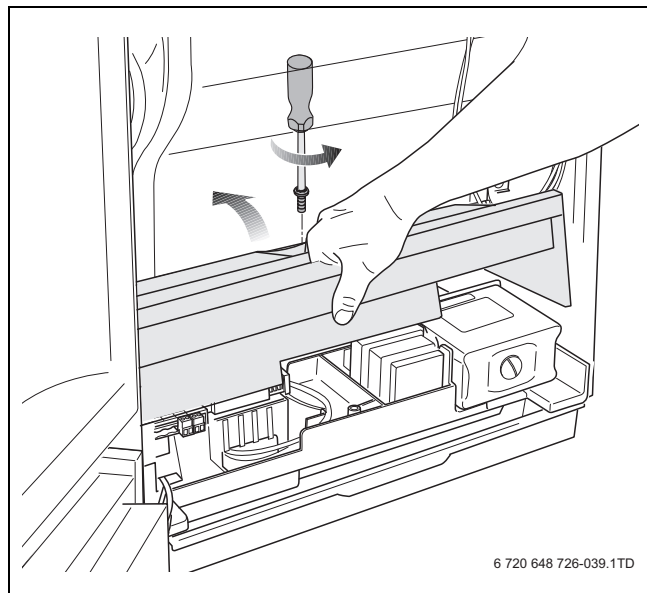

Fig. 39 Pull up the cover over the electrical connections

The terminal strip in the boiler (→ fig. 40) has a number of terminals to connect internal and external electrical components. The listing below shows which components must be connected to which terminals (→ section 7.5.4, page 36).

**i** If uncertain how to connect controls to this appliance, first contact the Worcester technical helpline on 0330 123 3366 or your supplier.

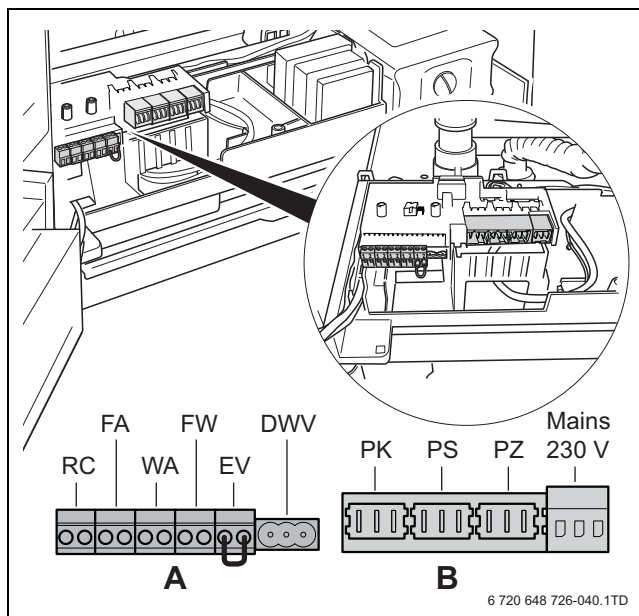

Fig. 40 Terminal strip

- [A] Low-voltage connections
- [B] 230 V connections

### 8.5.3 Routing the cable through the boiler

- ▶ Route the cable for the low-voltage connections through the hole on the left [1].
- ▶ Route the cable for the 230 V-connections through the hole on the right [2].
- ▶ Attach the cable for the 230 V-connections using the strain relief clamps [3].

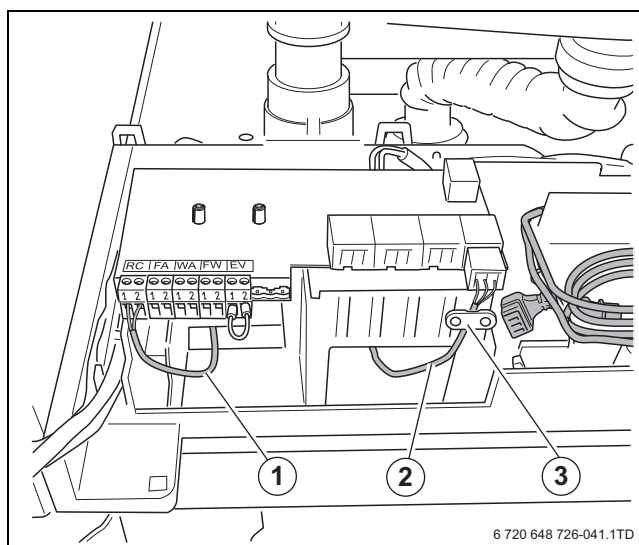

Fig. 41 Routing the cable

### 8.5.4 Description of the terminal strip connections

- ▶ Connect all components to the relevant terminals.



**DANGER:** Danger of fatal accident due to electric shock. Items 1 – 6 are low-voltage connections and items 7 – 10 are 230 V-connections (→ fig. 42).  
▶ Please be aware that there may be a voltage on items 7 – 10 (230 V), when power is supplied to the boiler.

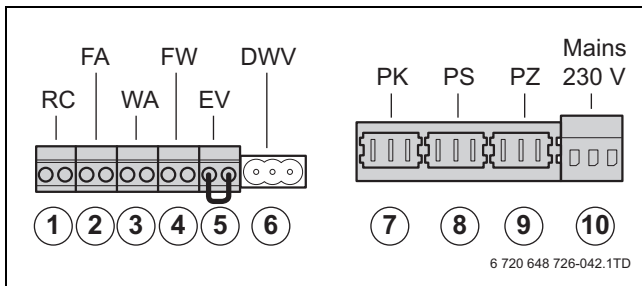

Fig. 42 Terminal strip connections

- [1] Room controller RC and EMS bus (connection colour orange)
- [2] Outdoor-temperature sensor (connection colour blue)
- [3] Connection terminal for potential free heat demand (connection colour green)
- [4] DHW temperature sensor (connection colour grey)
- [5] External switch contact, potential free, e. g. for floor heating (connection colour red) (thermal protection)
- [6] Connection for external three-way valve
- [7] External heating pump 230 V (connection colour green) (for use with non Worcester pump group)
- [8] DHW pump 230 V (connection colour grey)
- [9] DHW Circulation pump 230 V (connection colour lilac)
- [10] Mains connection 230 V AC (connection colour white)

**General control connection**

The following controls can be connected to the boiler.

- Control with contact for potential free heat demand
- RC25, RC35 room controller
- 4121, 4122, 4323 cascade controller
- Error reporting module EM10, 0 – 10 V input (can be used to convert a 0 – 10 V signal to a modulating signal).

**Connecting and installing a modulating control (room controller)**

**i** It is **not** possible to connect more than one room controller (→ fig. 43).

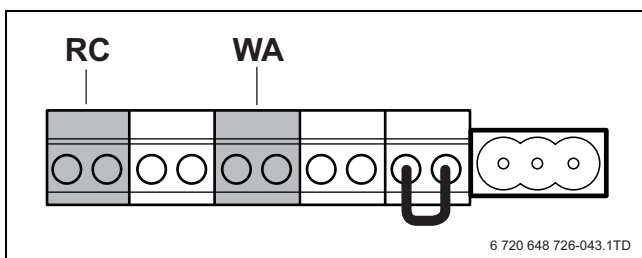

Fig. 43 Terminal strip – RC room controller and WA potential-free heat demand

**Installing an RC35 room controller as an outdoor temperature-dependant control in the boiler**

For outdoor temperature-dependant control operation only: it is possible to install the room controller (e.g. RC35) in the boiler. In this case, the controller does not have to be connected to the terminal strip afterwards. If you would like to use this room controller for room temperature-controlled operation, the room controller must be installed in a living room.

▶ Push the arrow on the control panel cover to open (→ fig. 44).

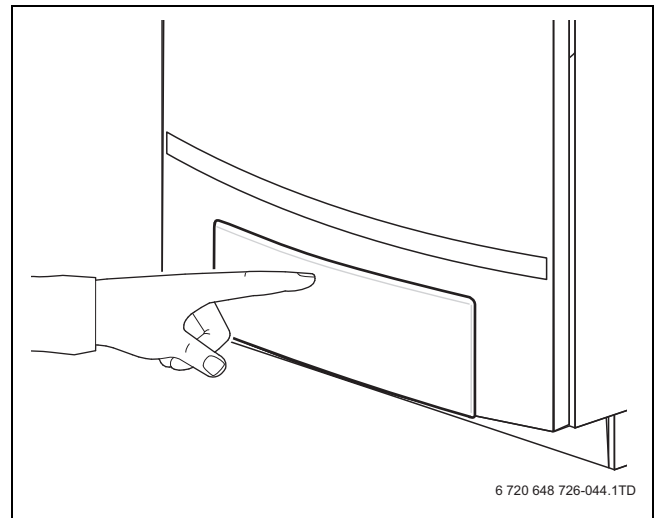

Fig. 44 Opening the control panel

- ▶ Remove the cover [1].
- ▶ Install the RC35 in the slot [2].

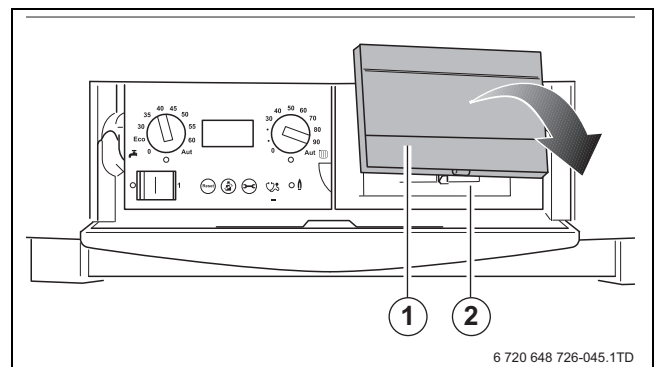

Fig. 45 Remove the cover and install the room controller in the boiler (only for outdoor temperature-dependant operation)

**i** If you install the room controller (e.g. RC35) in the boiler, only outdoor temperature-controlled operation is possible. See the room controller user manual for further information.

**Installing and connecting other controllers outside the boiler**

- ▶ Install the controller as described in the relevant installation instructions.
- ▶ Connect a RC25 or RC35 room controller or a 4121, 4122 or 4323 cascade controller to the orange RC terminal using a 2-core cable of 0.75 mm<sup>2</sup>.

**i** This connection is reverse-proof. This means that it does not matter in which order the wires are connected.

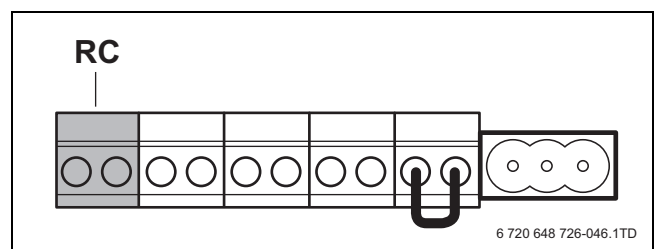

Fig. 46 Terminal strip – Room controller RC and EMS bus (connection colour orange)

### Connecting the outdoor temperature sensor

If outdoor temperature-dependant control operation is used, an outdoor temperature sensor must be connected.

- ▶ Connect the outdoor temperature sensor to the blue FA terminal, using a 2-core cable of 0.75 mm<sup>2</sup>.



This connection is non polarity sensitive. This means that it does not matter which order the wires are connected.

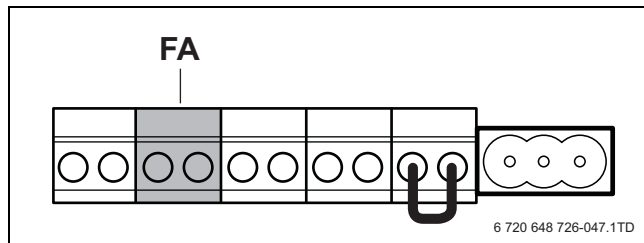

Fig. 47 Terminal strip - Outdoor-temperature sensor (connection colour blue)

### Connecting the potential-free heat demand

- ▶ Connect the potential-free heat demand contact to the green WA terminal (→ fig. 48). The maximum allowed resistance of this circuit is 100 Ω. Use a 2-core cable of 0.75 mm<sup>2</sup>.

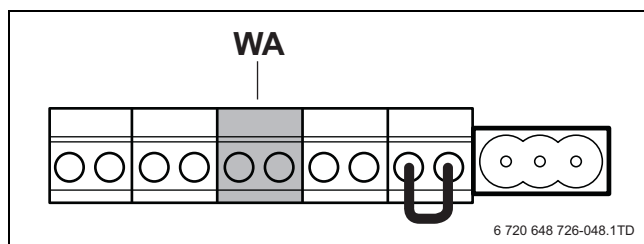

Fig. 48 Terminal strip - potential-free heat demand (connection colour green)



#### NOTICE:

- ▶ It is not possible to connect a thermostat simultaneously to the RC connection and to the terminal for the potential-free heat demand (WA) (→ fig. 49).
- ▶ It is possible to operate the boiler with an On/Off contact for potential-free heat demand, but the room temperature-based modulating function of the boiler cannot then be used anymore. This has a negative effect on comfort and energy consumption. If an On/Off contact for potential-free heat demand is installed, the boiler will only modulate up to the preset CH flow temperature.
- ▶ This connection is reverse-proof. This means that it does not matter which order the wires are connected.

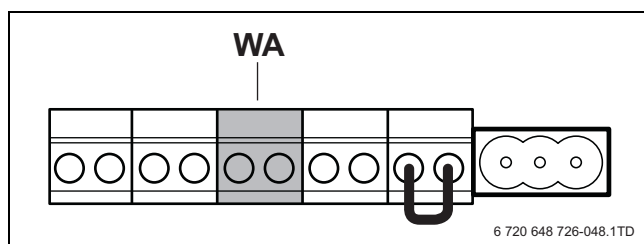

Fig. 49 Terminal strip - WA potential-free heat demand

### Connecting the DHW temperature sensor

- ▶ Connect the DHW temperature sensor to the grey FW terminal, using the harness enclosed with the DHW temperature sensor [1].



#### NOTICE:

- ▶ This connection is reverse-proof. This means that it does not matter in which order the wires are connected.
- ▶ It is not possible to connect more than one DHW temperature sensor in the boiler. It is only possible to connect a DHW temperature sensor which is suitable for this boiler.

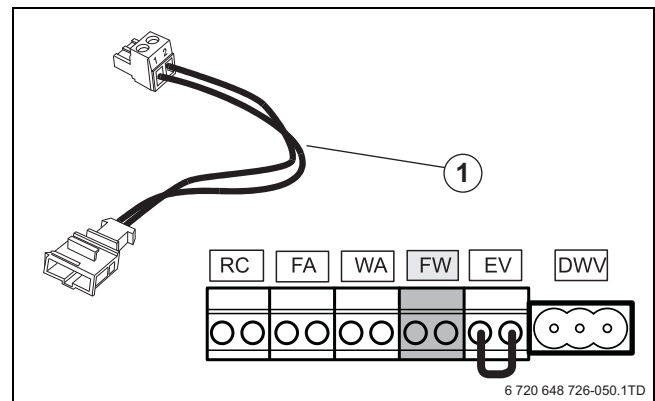

Fig. 50 Terminal strip - potential-free heat demand (connection colour green)

### Connecting an external switch contact

A potential-free external switch contact can be connected. This external switch contact can be used to safeguard a underfloor heating system so that the heating water temperature will not become too high etc. When the external switch contact is opened, the boiler will be switched off for heating operation and for domestic hot water operation. The pump continues to run for the run-over time set on the boiler.

- ▶ Remove the cable from the EV terminal.
- ▶ Connect the external switch contact to the red EV terminal.



This connection is reverse-proof. This means that it does not matter in which order the wires are connected.

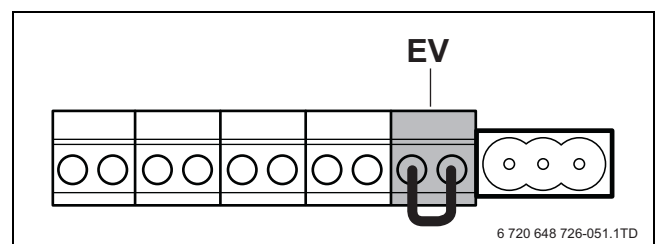

Fig. 51 Terminal strip - external switch contact, potential-free, e. g. for floor heating (connection colour red)

### Connecting external 230 V controls with use of the 230 Volt converter (only for GB162-50/65)

The gas wall hung boiler condensing can be fitted with the following external controls:

- a room-temperature control device at 230 V connected to the room control converter (only for GB162-50/65). For connection, see the electrical wiring diagram supplied with the 230 Volt converter),
- ON/OFF temperature controller, Volt free.

**WARNING:**

- ▶ This appliance must be earthed.

- ▶ Connect the black pre-wired main appliance lead to a permanent live supply (from the same fused isolator as all other controls on the heating system), L N E.

**NOTICE:**

- ▶ Connect the 230 Volt converter (grey box) via the pair of black low voltage cable to terminal WA. (→ figure 48).

- ▶ Remove the grey cover of the 230 Volt converter [1].
- ▶ Feed the 230 V switch live and neutral (from external controls) through the cable gland.
- ▶ Identify the 230 V terminal block by the hashed area and 230 VAC warning triangle.
- ▶ Connect the switch live to terminal "1" and a neutral to terminal "2" [2].

**NOTICE:**

- ▶ Terminal 3 [2] is not used.

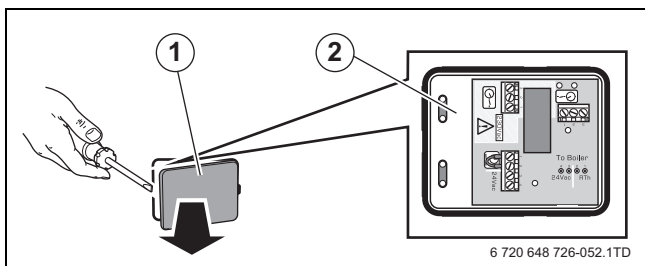

Fig. 52 Connection box - 230 Volt connection

### 8.5.5 230 V connections (only for GB162-50/65)

**NOTICE:**

The 230 V connections can only be used with a corresponding control unit. If you use other than the GB162 pump group, you must ensure that it correctly connects to the terminal strip in fig. 53.

- ▶ Observe the layout document and the installation instructions of the control unit.

**WARNING:**

- ▶ Do not connect a temperature controller to the 230 V connections.

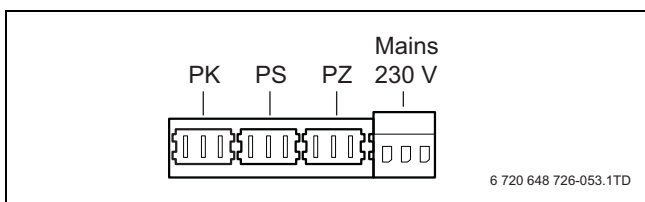

Fig. 53 Terminal strip - external heating pump 230 V (connection colour green)

### Connecting an external boiler pump - general

Since the boiler has not been fitted with a pump, a pump must be connected to the boiler.

When using a pump group with an integrated pump:

- ▶ Read the assembly instructions of the pump group for the electrical pump connections.

If you do not make use of a pump group, you can connect the external pump in 2 ways:

- to the unused 230 VAC pre-wired pump cable;
- to the green PK terminal of the boiler. To connect order a PK plug (accessory).

Proceed as follows:

**WARNING:**

- ▶ Damage to the installation by the boiler being overloaded.

The maximum electrical load that can be connected to the free 230 VAC connection cable of the pump (→ fig. 54, [1]) and to the green EP connector (→ fig. 56) is 250 Watts in total. If a load of more than 250 Watts is to be connected, this is possible by using an additional 230/230 V relay, which has to be installed by a registered installer/ electrician.

### Connection to the free 230 VAC connection lead

- ▶ Unwind the 230 VAC cable [1] and route it out of the boiler (→ fig. 55).

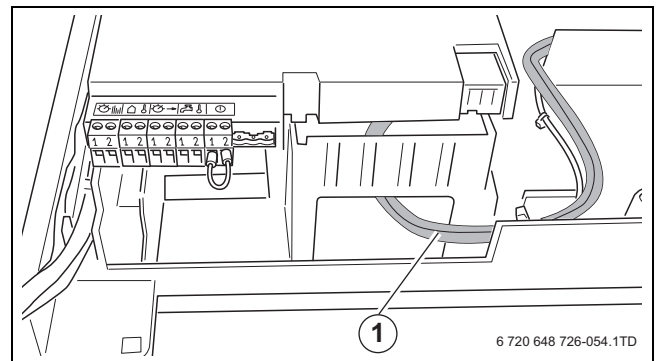

Fig. 54 230 VAC cable of the pump

- ▶ Cut the plug from the 230 VAC cable.
- ▶ Connect the 230 VAC cable to the pump.

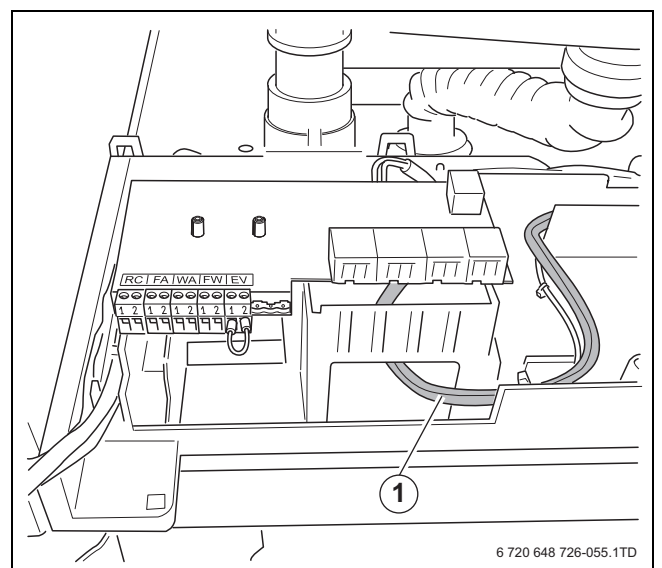

Fig. 55 Route the 230 VAC pump cable

**Installation**

**Connection to the terminal strip of the boiler**

- ▶ Connect the external pump, if available, (not the pump of the pump group) to the green PK terminal. The maximum allowed connected load of the pump = 250 Watts.

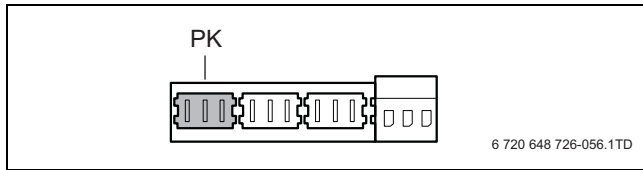

Fig. 56 Terminal strip - external heating pump 230 V (connection colour green)

**Connecting the DHW pump**

- ▶ Connect the DHW pump to the grey PS terminal. The maximum allowed connected load of the pump = 250 Watts.

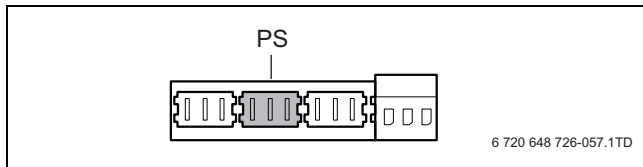

Fig. 57 Terminal strip - DHW pump 230V (connection colour grey)

**Connecting the DHW circulation pump**

- ▶ Connect the DHW circulation pump to the lilac PZ terminal. The maximum allowed connected load of the pump = 250 Watts.

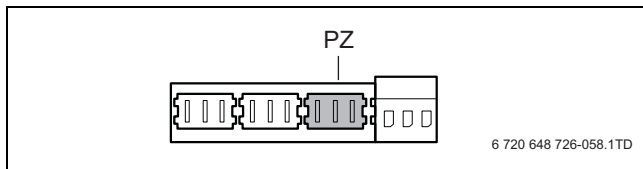

Fig. 58 Terminal strip - DHW pump 230 V (connection colour grey)

**Connecting to the mains**

**i** All Worcester boilers require a permanent live.

A mains supply of 230 V - 50 Hz is required.

External controls are suitable for volt free installation.

Wiring to the boiler **must** be in accordance with the current I.E.E. (BS 7671) Wiring Regulations and any local regulations.

Wiring should be a 3 core PVC insulated cable, not less than 0.75 mm<sup>2</sup> (24 x 0.2 mm), and to table 16 of BS 6500.

Connection must be made in a way that allows complete isolation of the electrical supply such as a double pole switch having 3 mm contact separation in both poles, or by a three pin connector, serving only the boiler and system controls. This boiler is equipped with a double pole switch [1]. The means of isolation must be accessible to the user after installation.

The electrical connection to the mains supply should be readily accessible and adjacent to the boiler.

If the supply cord is damaged, it must be replaced by a registered Gas Safe installer to avoid a hazard and must be an original spare part.

The electrical supply for both the boiler and the system must be taken from the same fused spur outlet.

**⚡ DANGER:** Danger of fatal accident due to electric shock.

- ▶ Disconnect the boiler from the mains power supply before working on the boiler.

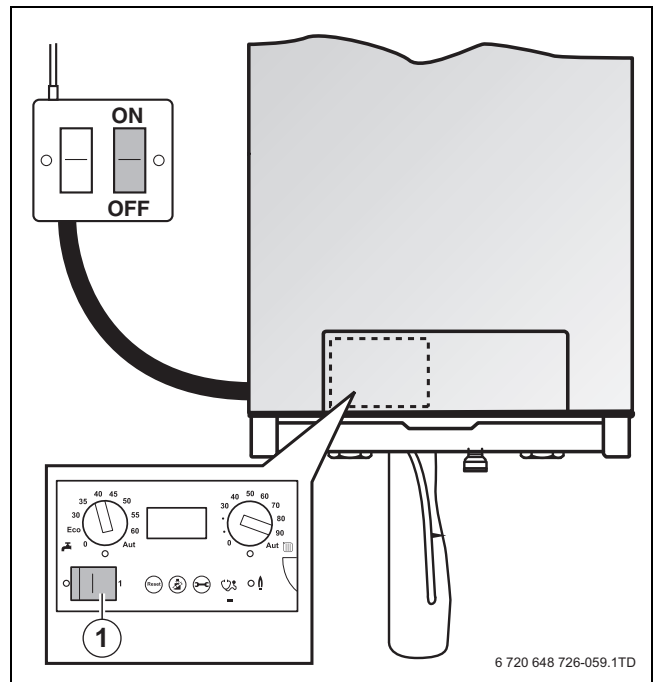

Fig. 59 Mains supply

**8.5.6 Installing function modules (accessories)**

**i** Refer to the installation instructions of the relevant function modules for information about installation and combination possibilities.

The following function modules (accessories) can be connected to the boiler:

- Heat demand 0-10 V module EM10
- Error reporting module EM10
- Switch module WM10
- Mixing module MM10
- Solar module SM10.

Function modules (accessories) can be installed in 2 ways:

- in the boiler (max. 2)
- outside the boiler.

Both methods are described below.

- ▶ Determine how the modules have to be installed.

**Installing and connecting function modules (accessories) in the boiler**

- ▶ Loosen the screw [1].
- ▶ Pull open the draw [2].

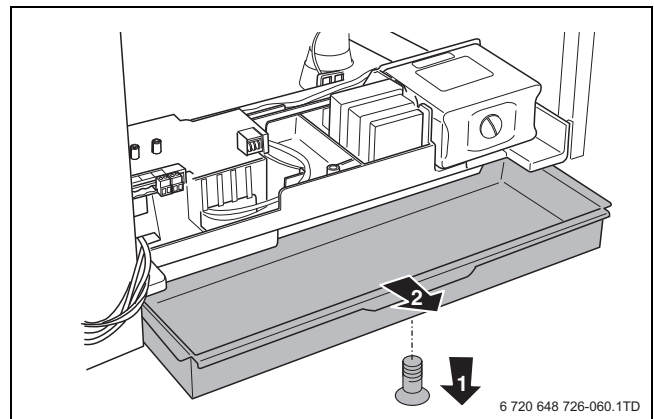

Fig. 60 Opening the draw

- ▶ Install the wall bracket (accessory with function module) in the relevant slots in the draw.

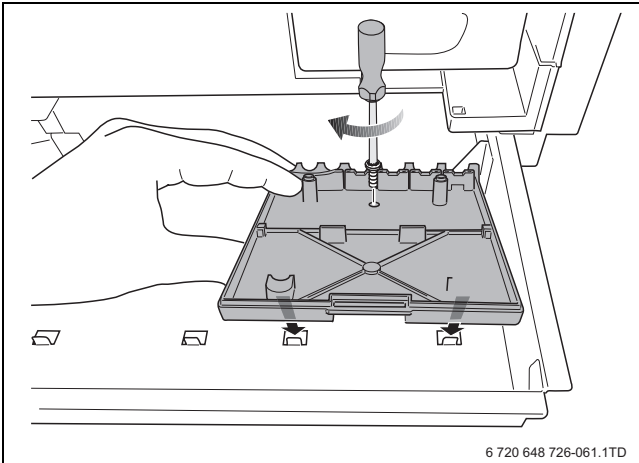

Fig. 61 Installing the wall bracket

- ▶ Click the function module(s) into place in the wall bracket.
- ▶ Remove the draw.

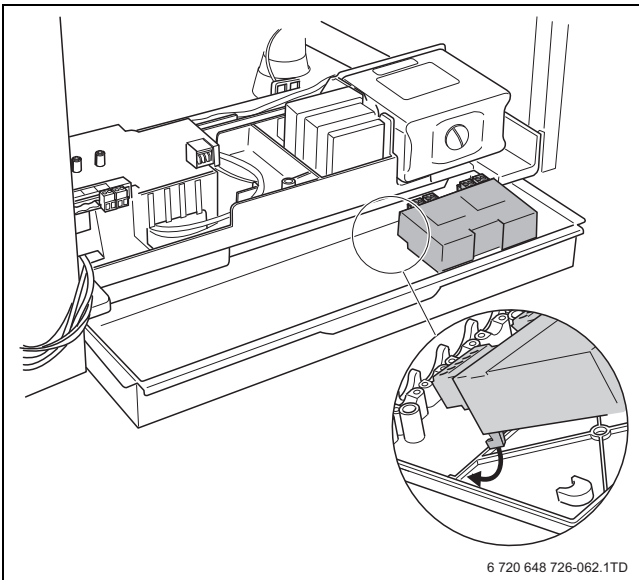

Fig. 62 Clicking the function module into place in the wall bracket

- ▶ Remove the covers of both free connectors on the function module connection cables.
- ▶ Slide the draw back into the boiler.

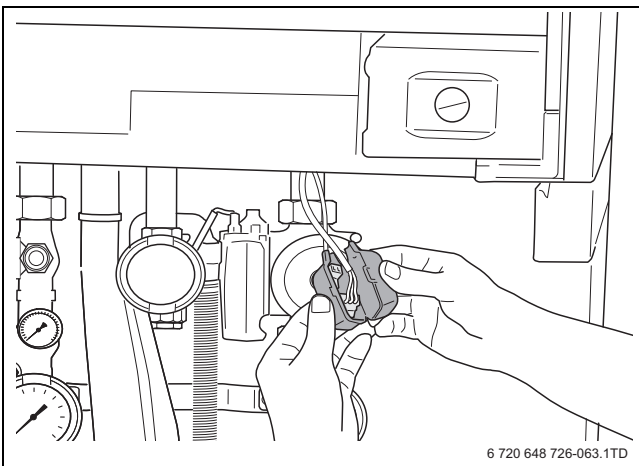

Fig. 63 Removing the covers

- ▶ Connect the free 230 VAC mains cable (→ fig. 63) to the module [1]. If more modules are used, the 230 VAC supply for the second module can be taken from the first module using the cable enclosed with the module.

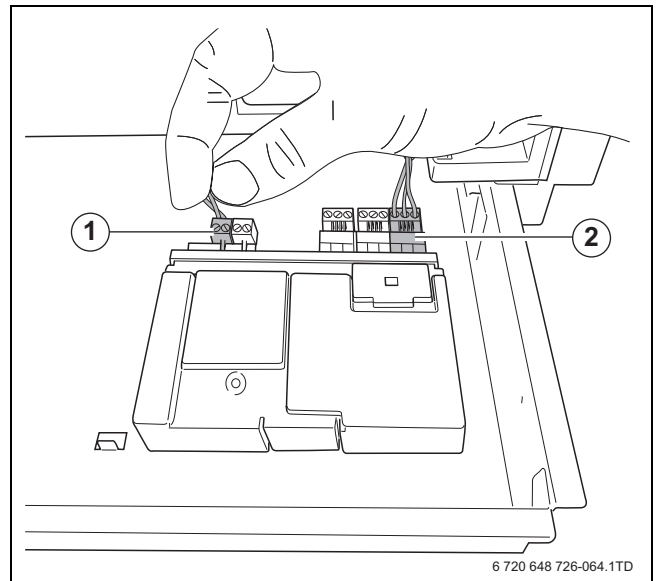

Fig. 64 Interconnecting modules

- ▶ Connect the 230 VAC mains cable of the first module to the next module.



The module may have the letters RC or EMS above the connection [1].

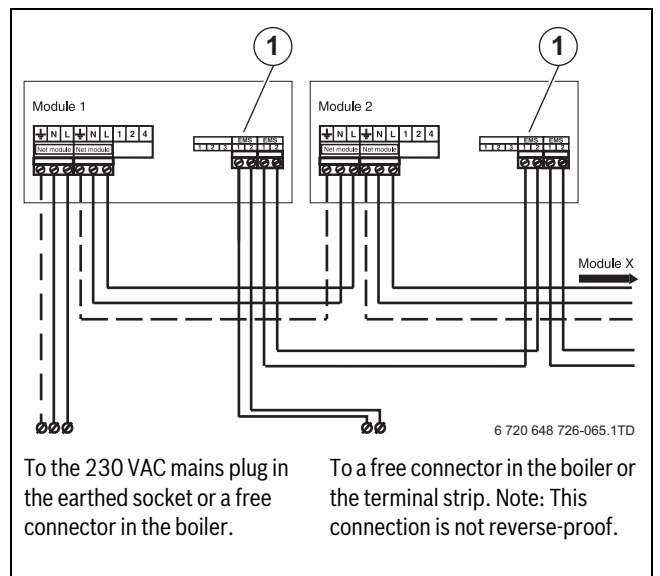

Fig. 65 Connecting several modules

- ▶ Connect the free connector of the EMS bus connecting cable to the first module (→ fig. 64, [2]).
- ▶ If more modules are used, the EMS bus connection for the second module may be branched off from the first module using the cable enclosed with the module (→ fig. 65 and 66).



**NOTICE:**

Pay attention to the polarity when using an EMS bus connection cable.

- ▶ Connect the wire from terminal 1 to terminal 1 and from terminal 2 to terminal 2 (→ fig. 65 and 66).

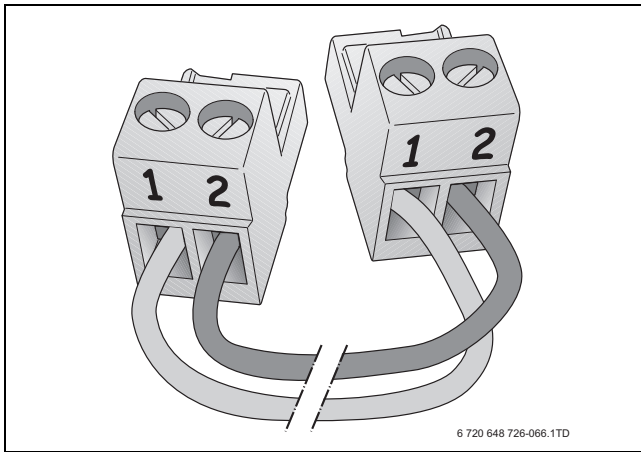

Fig. 66 EMS bus polarity

**Installing and connecting function modules outside the boiler**

- ▶ Install the module on the wall.
- ▶ Make a sufficiently long EMS bus connection cable, using a 2-core cable of 0.4 - 0.75 mm<sup>2</sup> and the connector enclosed with the module (→ fig. 66). Important: Use the connector of the same colour as the connections on the module.

**NOTICE:**

Pay attention to the polarity when using an EMS bus connection cable.

- ▶ Connect the wire from terminal 1 to terminal 1 and from terminal 2 to terminal 2 (→ fig. 65 and 66).

- ▶ Connect the EMS bus connection cable to the orange connection of the terminal strip [1].

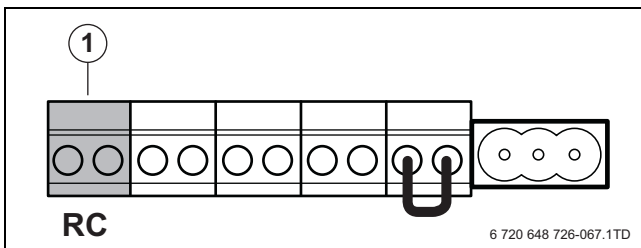

Fig. 67 Terminal strip - Room controller RC and EMS bus (connection colour orange)

- ▶ Connect the other end of the EMS bus connection cable to the first module (→ fig. 65).

**i** The module may have the letters RC or EMS above the connection (→ fig. 65, [1]).

- ▶ If more modules are used, the EMS bus connection for the second module may be branched off from the first module using the cable enclosed with the module.
- ▶ Connect the EMS bus connection lead of the first module to the next module (→ fig. 65).
- ▶ Make a sufficiently long 230 VAC mains cable, using a 3-core cable of at least 0.75 mm<sup>2</sup> with an earthing wire, the connector enclosed with the module and a 230 VAC earthed plug.
- ▶ Connect the 230 VAC mains cable to the module (→ fig. 65). If more modules are used, the 230 VAC supply to the next module can be branched off from the previous module using the connector enclosed with the module and a 3-core 0.75-mm<sup>2</sup> current cable with an earthing wire.
- ▶ Connect the 230 VAC supply cable of the previous module to the next module (→ fig. 65).

**9 Operation**

**9.1 General items**

The boiler is fitted with a control unit, the BC10 basic controller. This controller can be used to control the heating system.

- ▶ Push on the control panel to open it.

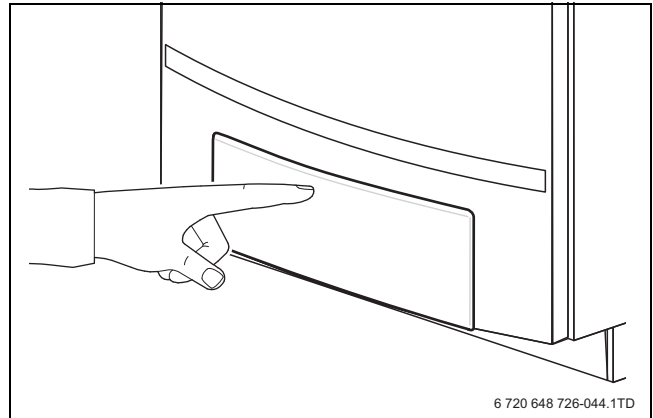

Fig. 68 Opening the control panel

The BC10 basic controller is located on the left, behind the door (→ fig. 1, [4]).

The BC10 basic controller consists of the following components:

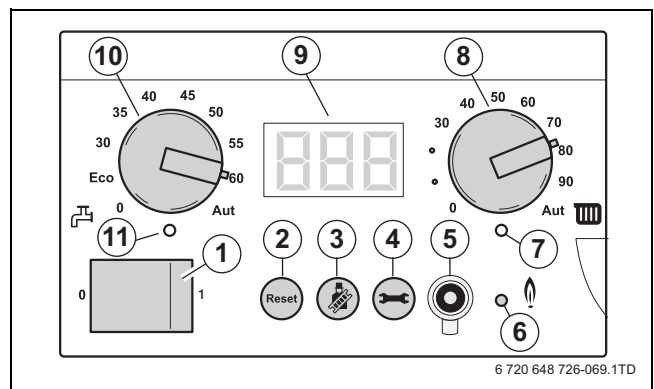

Fig. 69 BC10 basic controller

- [1] Mains switch
- [2] "Reset" button
- [3] "Chimney sweep" button
- [4] "Service button"
- [5] Service Connector
- [6] "Burner" LED (On/Off)
- [7] "Heat demand" LED
- [8] Maximum CH flow temperature dial
- [9] Display
- [10] DHW temperature dial
- [11] "DHW mode" LED

**Mains switch**

The mains switch [1] is used to switch the boiler on and off.

**"Reset" button**

If a fault has occurred you may have to restart the boiler by pressing the "Reset" button [2]. This is only required in the event of a "locking" fault. "Blocking" faults are reset automatically as soon as their cause has been corrected. The display shows **rE** during the reset operation.

**i** If the boiler stops due to a fault again after resetting the fault, the fault can be remedied using the Service instructions. Contact Worcester if necessary. See the back of this document for contact details.

**“Chimney sweep” button**

The “Chimney sweep” button ([3]) is used to put the boiler into flue gas test, service or manual operation mode.

The flue gas test enables the boiler to be run in full-load operation manually for a short period. See table 10, “Flue gas test”, page 34.

The service mode enables the boiler to be run in part-load operation manually for a short period. Measurements and settings are carried out on the boiler during service mode. (→ table 11, “Service mode”, page 34).

Manual operation mode enables the boiler to be operated manually for a long period. The boiler is switched to manual mode when the control system has not been installed yet or is out of order (→ table 12, “Manual operation”, page 35).

A maximum heating water temperature in accordance with the setting of the “Maximum heating water temperature” dial [8] on the BC 10 basic controller applies during chimney sweep, service and manual operation.

	<p><b>WARNING:</b> Damage to the installation with underfloor heating: by the floor being overheated.</p> <ul style="list-style-type: none"> <li>▶ Limit the maximum CH flow temperature using the “Maximum CH flow temperature” dial [8] to the maximum flow temperature of the floor heating circuit (usually maximum 40 °C).</li> </ul>
--	--

	<p><b>WARNING:</b> Damage to the installation due to frost while manual operation is switched on. After a power failure or after switching off the supply voltage, the heating system may freeze since manual operation is no longer active then.</p> <ul style="list-style-type: none"> <li>▶ Start manual operation after switching on the heating system, so that the system is permanently in operation (especially if there is a risk of freezing).</li> </ul>
--	---

**“Service” button**

The “Service” button [4] is used to display the current CH flow temperature, the current system pressure etc. Also see table 22, “BC10 Display readings”, page 53, table 23, “BC10 Display settings”, page 54 and table 24, “BC10 Display codes”, page 54.

**Service Tool connection**

This service connection is for Worcester service engineers only.

**“Burner” (On/Off) LED**

The “Burner” (On/Off) LED (→ fig. 69, [6]) lights up when the burner of the boiler is active and it is extinguished when the burner is switched off.

The “Burner” (On/Off) LED indicates the burner status.

LED	Status	Explanation
On	Burner operational	Boiler water is being heated.
Off	Burner off	The CH (boiler) flow temperature has reached the set temperature or there is no heat demanded.

Table 8 Meanings of “Burner” (On/Off) LED indications

**“Heat demand” LED**

The “Heat demand” LED (→ fig. 69, [7]) lights up when the control system has made a heat demand and it is extinguished when this heat demand is no longer required.

**Maximum CH (boiler) flow temperature dial**

The maximum CH (boiler) flow temperature (→ fig. 69, [8]) is used to set the upper CH (boiler) flow temperature limit. The unit is °C.

**Display**

The heating system display values, display settings and display codes can be read out from the display (→ fig. 69, [9]). If a fault occurs the display will immediately show the accompanying fault code. The fault code display will flash if a locking fault is detected.

**“DHW mode” LED**

The “DHW mode” LED (→ fig. 69, [10]) lights up when a DHW request has occurred and it is extinguished when this DHW request is no longer required.

**DHW temperature dial (Only functional when used in conjunction with Bosch controllers)**

The DHW temperature dial (→ fig. 69, [11]) is used to select the required temperature of the hot water in the hot water cylinder. The unit is °C (→ table 18, page 44).

**9.2 BC10 control operating instructions**

You can navigate through the menu structure of the boiler on the BC10 using the “Reset” button, the “Chimney sweep” button, the “Service button” (→ fig. 69, items 2, 3 and 4) and the display (→ fig. 69, [9]) using table 9 to table 13.

The menu structure consists of 5 menus:

- Normal Operation menu
- Flue Gas Test menu
- Service Mode menu
- Manual Operation menu
- Settings menu.

Normal operation menu		
<b>Step 1</b>	Display value. Currently measured CH flow temperature in °C. Also see section 14.2, page 53.	
<b>Step 2</b>	Continue in Normal operation menu?	Yes: → step 3 No: → step 1
<b>Step 3</b>	Press the ⊖ button.	
<b>Step 4</b>	Display value. Currently measured system pressure in bar. Also see section 14.2, page 53.	
<b>Step 5</b>	Press the ⊖ button.	
<b>Step 6</b>	Random display code. In this case: Operating phase: Boiler in heating mode. Also see section 14.3, page 54.	
<b>Step 7</b>	Have at least 5 seconds passed without a button being pressed and/or has the mains voltage been interrupted?	Yes: → step 1 No: → step 8
<b>Step 8</b>	Press the ⊖ button.	→ step 1

Table 9 Normal operation





Flue Gas Test menu		
<b>Step 1</b>	<span>24</span> Display value. Currently measured CH flow temperature in °C. Also see section 14.2, page 53.	
<b>Step 2</b>	Activate flue gas test?	Yes: → step 3 No: → step 1
<b>Step 3</b>	To activate the flue gas test: Press and hold the  button for more than 2 but not longer than 5 seconds	
<b>Step 4</b>	<span>24</span> Display value. As soon as a non-flashing dot is shown in the right-hand bottom corner of the display, the flue gas test has been activated. This means that the boiler is in heating mode at a capacity of 100 % for a maximum of 30 minutes. The maximum CH flow temperature as set on the maximum CH flow temperature dial of the BC10 basic controller now applies. DHW mode is possible during manual operation.	
<b>Step 5</b>	Press the  button.	
<b>Step 6</b>	<span>P 16</span> Display value. Currently measured system pressure in bar. Also see section 14.2, page 53.	
<b>Step 7</b>	Press the  button.	
<b>Step 8</b>	<span>- H</span> Display code: Operating phase: The boiler is in flue gas test mode. Also see section 14.3, page 54.	
<b>Step 9</b>	Press the  button.	
<b>Step 10</b>	<span>24</span> Display value. Currently measured CH flow temperature in °C. Also see section 14.2, page 53.	
<b>Step 11</b>	Have 30 minutes passed or has the mains voltage been interrupted?	Yes: → step 1 No: → step 12
<b>Step 12</b>	Deactivate flue gas test?	Yes: → step 13 No: → step 5
<b>Step 13</b>	To deactivate the flue gas test: Press and hold the  button for more than 2 seconds until the dot disappears. → step 1	

Table 10 Flue gas test







Service Mode menu		
<b>Step 1</b>	<span>24</span> Display value. Currently measured CH flow temperature in °C. Also see section 14.2, page 53.	
<b>Step 2</b>	Activate service mode?	Yes: → step 3 No: → step 1
<b>Step 3</b>	To activate service mode 1st step: Press and hold the  button for more than 2 but not longer than 5 seconds	
<b>Step 4</b>	<span>24</span> Display value. As soon as a non-flashing dot is shown in the right-hand bottom corner of the display, the boiler is in heating mode at a capacity of 100 % for a maximum of 30 minutes. The maximum CH flow temperature as set on the maximum CH flow temperature dial of the BC10 basic controller (control panel) now applies.	
<b>Step 5</b>	To activate service mode 2nd step: Simultaneously press and hold the  +  buttons for more than 2 seconds.	
<b>Step 6</b>	<span>L - -</span> Display setting. Maximum capacity setting during heating mode in %. Also see section 14.3, page 54. In this case: <span>L - -</span> = 100 %. Service mode has been activated. You can now temporarily lower the boiler performance to partial load to check and if relevant set the gas/air ratio or the ionisation current.	
<b>Step 7</b>	Press and hold the  button until the display shows <span>L 25</span> with a 80-kW boiler, <span>L 20</span> with a 65 and 100-kW boiler or <span>L 30</span> with a 50-kW boiler.	
<b>Step 8</b>	<span>L 25</span> Display setting: with a 80-kW boiler, <span>L 20</span> with a 65 or 100-kW boiler and <span>L 30</span> with a 50-kW boiler. Minimum capacity setting during heating mode in %. Also see section 14.3, page 54. The boiler will reduce its performance to 25 % or 20 % respectively within a couple of seconds. The maximum CH flow temperature set on the BC10 basic controller (control panel) applies now. Check the gas/air ratio or the ionisation current and if necessary set the gas/air ratio according to subsection 10.2.7 or subsection 10.2.11.	
<b>Step 9</b>	Press the  button.	
<b>Step 10</b>	<span>F 5</span> Display setting: This parameter shows the pump run-over time in minutes when heating mode has been ended. Also see section 14.3, page 54.	
<b>Step 11</b>	Press the  button.	
<b>Step 12</b>	<span>C I</span> Display setting: This parameter indicates the DHW mode status setting. Also see section 14.3, page 54.	
<b>Step 13</b>	Press the  button.	

Table 11 Service mode

Service Mode menu		
<b>Step 14</b>	24	Display value. Currently measured CH flow temperature in °C. Also see section 14.3, page 54.
<b>Step 15</b>		Press the  button.
<b>Step 16</b>	P 1.6	Display value. Currently measured system pressure in bar. Also see section 14.3, page 54.
<b>Step 17</b>		Press the  button.
<b>Step 18</b>	- H	Display code: Operating phase: The boiler is in service mode. Also see section 14.3, page 54.
<b>Step 19</b>		Press the  button.
<b>Step 20</b>	24	Display value. Currently measured CH flow temperature in °C. Also see section 14.3, page 54.
<b>Step 21</b>		Have 30 minutes passed or has the mains voltage been interrupted? Yes: → step 22 No: → step 23
<b>Step 22</b>		Service mode is deactivated. → step 25
<b>Step 23</b>		Deactivate service mode? Yes: → step 24 No: → step 15
<b>Step 24</b>		To deactivate the service mode: Press and hold the  button for more than 2 seconds until the dot disappears.
<b>Step 25</b>		The boiler capacity drops to the preset capacity, see the “Settings” menu (table 13). → step 1

Table 11 Service mode

Manual operation menu		
<b>Step 1</b>	24	Display value. Currently measured CH (boiler) flow temperature in °C. Also see section 14.2, page 53.
<b>Step 2</b>		Activate manual operation? Yes: → step 3 No: → step 1
<b>Step 3</b>		To activate manual operation: Press and hold the  button for more than 5 seconds.
<b>Step 4</b>	24	Display code: Operating phase: As soon as a flashing dot is shown in the right-hand bottom corner of the display, manual operation is active. This means that the boiler is permanently in heating mode. The maximum CH flow temperature as set on the maximum CH flow temperature dial of the BC10 basic controller (control panel) now applies. The “Heat request” LED lights up. DHW mode is possible during manual operation.
<b>Step 5</b>		Press the  button.
<b>Step 6</b>	P 1.6	Display value. Currently measured system pressure in bar. Also see section 14.2, page 53.
<b>Step 7</b>		Press the  button.
<b>Step 8</b>	- H	Display code: Operating phase: Also see section 14.3, page 54. The boiler is in manual operation mode. This means that the boiler is in heating mode while there is no heat request from the controller. During manual operation the “Settings” menu (table 13 from step 3) can be used to temporarily change the target boiler performance. <b>Note:</b> If the boiler performance has been changed temporarily, this must be set again after ending manual operation, according to the “Settings” menu (table 13, page 36).
<b>Step 9</b>		Press the  button.
<b>Step 10</b>	24	Display value. Currently measured CH flow temperature in °C. Also see section 14.2, page 53.
<b>Step 11</b>		Has there been a power failure? Yes: → step 1 No: → step 12
<b>Step 12</b>		Deactivate manual operation? Yes: → step 13 No: → step 5
<b>Step 13</b>		To deactivate manual operation: Press and hold the  button for more than 2 seconds until the dot disappears. → step 1

Table 12 Manual operation

Settings Menu		
<b>Step 1</b>	<span>24</span> Display value. Currently measured CH flow temperature in °C. Also see section 14.2, page 53.	
<b>Step 2</b>	Open the “Settings” menu?	Yes: → step 3 No: → step 1
<b>Step 3</b>	To open the “Settings” menu: Press and hold the  +  buttons for more than 2 seconds	
<b>Step 4</b>	<span>L - -</span> Display setting. As soon as the display shows <span>L - -</span> , the “Settings” menu is open. You can set the boiler performance using the first parameter shown on the display. Also see section 14.3, page 54.	
<b>Step 5</b>	Adjust boiler performance?	Yes: → step 7 No: → step 6
<b>Step 6</b>	Lower: Decrease the target boiler output with the  button. The minimum setting is <span>L 25</span> = 25 % with an 80-kW boiler, <span>L 20</span> = 20 % with a 65 or 100-kW boiler and <span>L 30</span> = 30 % with a 50-kW boiler. Higher: Increase the target boiler output with the  button. The maximum setting is <span>L - -</span> = 100 %. This is equal to the factory setting.	
<b>Step 7</b>	Press the  button.	
<b>Step 8</b>	<span>F 5</span> Display setting: Set the second parameter as soon as the display shows <span>F 5</span> . This parameter shows the target pump run-over time in minutes after heating operation has ended. Also see section 14.3, page 54. Note: Do not set a pump run-over time of less than <span>F 5</span> (= 5 minutes).	
<b>Step 9</b>	Set the pump run-over time after heating operation has ended?	Yes: → step 10 No: → step 11
<b>Step 10</b>	Lower: Decrease the target pump run-over time after the end of heating operation with the  button. The minimum setting is <span>F 0</span> = 0 minutes. The factory default setting is 5 minutes. <b>Caution:</b> Do not set the target pump run-over time after the end of heating operation to less than 5 minutes. Higher: Increase the target pump run-over time after the end of heating operation with the  button. The maximum setting is <span>F 60</span> = 60 minutes or <span>F 1d</span> = 24 hours.	
<b>Step 11</b>	Press the  button.	
<b>Step 12</b>	<span>C 1</span> Display setting. Set the third parameter as soon as the display shows <span>C 1</span> . This parameter indicates the DHW mode status setting. This enables DHW mode to be switched off or on. This setting has priority over other DHW mode settings, such as those made on the room thermostat. Also see section 14.3, page 54.	
<b>Step 13</b>	Set the DHW mode status?	Yes: → step 14 No: → step 15
<b>Step 14</b>	Set the DHW mode target status with the  or  buttons. <span>C 1</span> means “On”, <span>C 0</span> means “Off”. Please note: Setting <span>C 0</span> also switches off the hot water cylinder frost protection.	
<b>Step 15</b>	Have at least 5 seconds passed without a button being pressed and/or has the mains voltage been interrupted?	Yes: → step 17 No: → step 16
<b>Step 16</b>	Press the  button.	
<b>Step 17</b>	<span>24</span> Display value. Any adjustments that you have made have been confirmed.	→ step 1

Table 13 Settings

## 10 Commissioning



If a fault occurs, then refer to the servicing manual or contact Worcester.

This section explains how to start up the boiler.

- ▶ Complete the commissioning record log book after carrying out the activities described below (→ section 10.5 “Commissioning record log book”, page 45).

### 10.1 Filling the heating system

#### 10.1.1 Filling the heating system



At initial start up, the boiler will start up as soon as the system pressure exceeds 1.0 bar. If the system pressure falls to below 0.2 bar the boiler will stop and generate a fault code.

The pre-pressure of the expansion vessel must be at least equal to the static pressure (system height to the centre of the expansion vessel), however never less than 0.5 bar.

- ▶ Push on the control panel to open it (→ fig. 68).
- ▶ Turn the maximum CH flow temperature dial [8] and DHW temperature dial [10] anticlockwise to the “0” position.

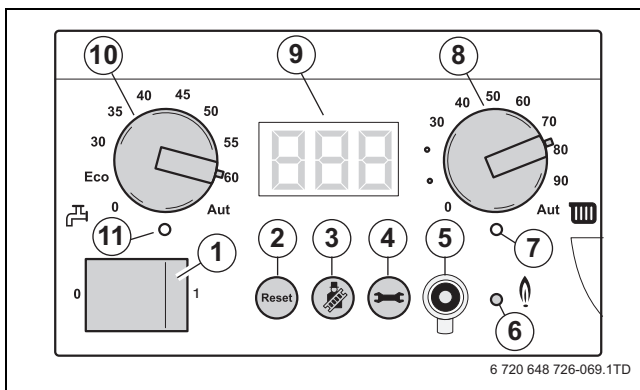

Fig. 70 BC10 basic controller

- ▶ Turn the vent key through a quarter rotation [1] to undo the boiler door lock (→ detailed picture).
- ▶ Push the fastener down [2] and open the boiler door [3].
- ▶ Remove the insulation cover of the pump group [4].

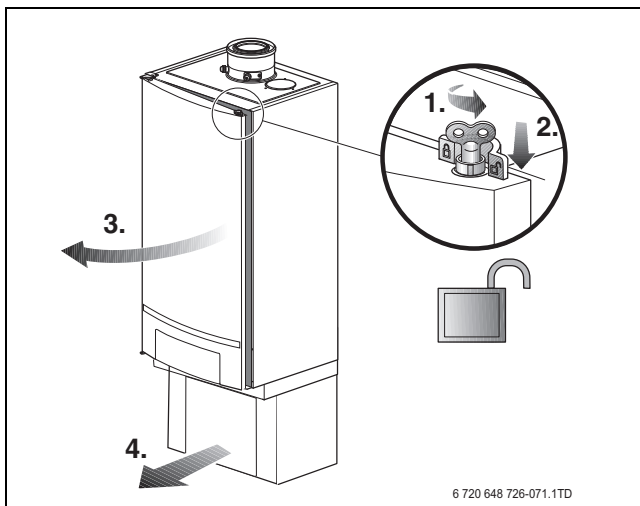

Fig. 71 Opening the boiler door

The boiler has an automatic air vent to purge the boiler.

To purge the boiler, every radiator in the heating system must have a purge facility. In some situations it may even be necessary to provide extra purging facilities at certain locations.

- ▶ Turn the cap of the automatic air vent through one rotation to loosen it.

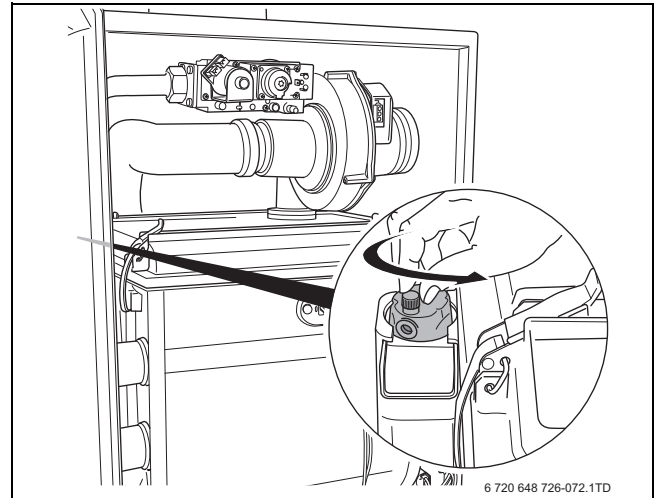

Fig. 72 Opening the automatic air purging unit

Filling and refilling of the heating circuit must have been carried out by a method that has been approved by the Water Regulation Advisory Scheme (WRAS), for the type of heating appliances, i.e. Domestic (in-house) Fluid Category 3. Non-Domestic (other than in-house) Fluid Category 4. Depending on the Fluid Category the approved method should comprise of the following:

#### Requirements Fluid Category 3 systems

- Control valve (stop valve) including a double check valve on the mains cold water supply pipe.
- Temporary connection to be removed after filling (filling loop).
- Control valve (stop valve) on the heating system pipework.

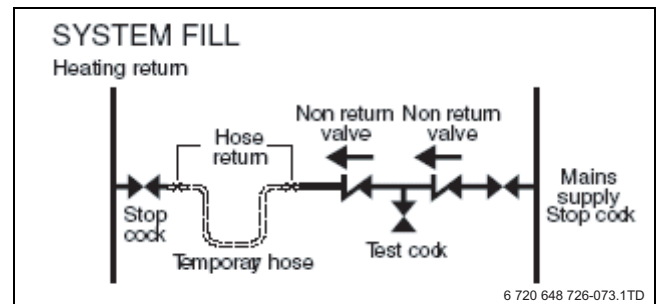

Fig. 73 System fill - category 3

#### Requirements Fluid Category 4 systems

- Control valve (stop valve) on the mains cold water supply pipe.
- Strainer.
- Water non-return valve with reduced pressure Zone (RPZ valve assembly) incorporating a Type BA air gap.
- Tundish.
- Control valve (stop valve) on the heating system pipework.

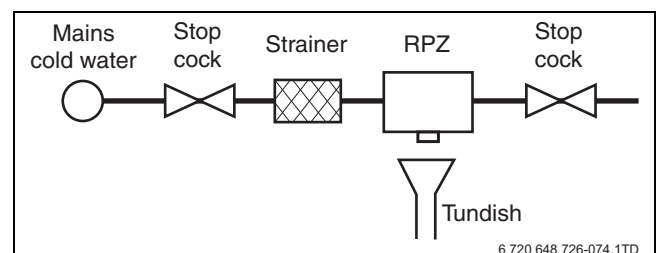

Fig. 74 System fill - category 4

- ▶ Open the heating flow and return isolating valves on the pump group (open position: parallel to the pipe).

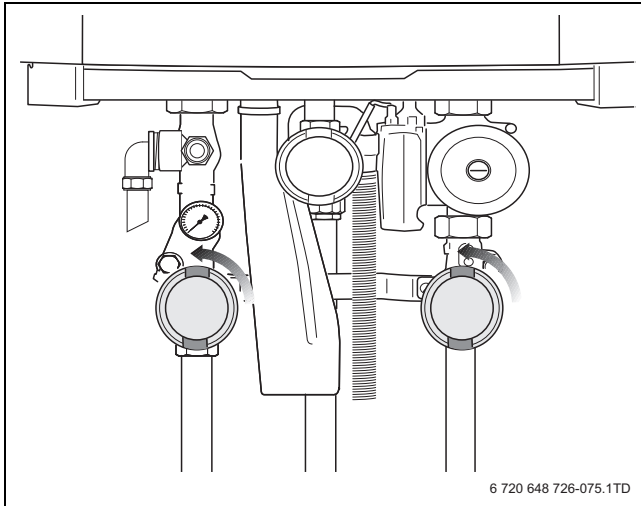

Fig. 75 Opening the isolating valves (here: open position)

- ▶ Read the pressure from the pressure gauge on the pump group or on the control panel of the BC10.

The pressure in the heating system, which is measured directly at the boiler, must be at least equal to the required pre-pressure of the expansion vessel plus 0.5 bar. This minimum pressure must not be less than 1.0 bar (if the heating system is cold). The maximum pressure in the heating system, measured directly at the boiler, must not exceed 3.5 bar.

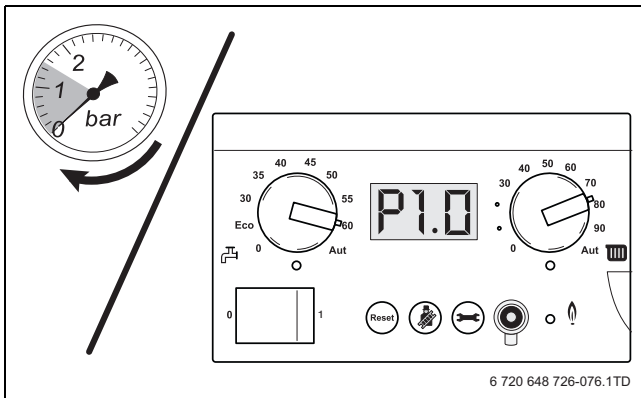

Fig. 76 Reading the pressure gauge

- ▶ Purge the heating system via the air vents on the radiators. Start at the lowest floor of the premises and then work your way up from floor to floor.

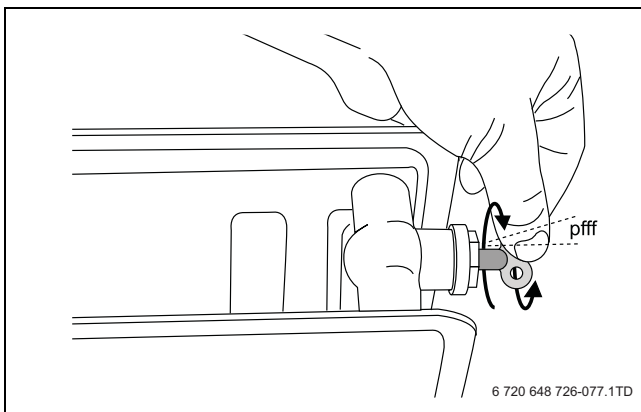

Fig. 77 Purging the heating system

If the boiler has been in use for approximately one week and the pressure reading on the display is less than 1.0 bar, the system has to be topped up.

The pressure loss in a heating system is caused by air bubbles escaping via fittings and (automatic) air vent units. The oxygen contained in the fresh heating water will also escape from the heating water after some time and cause the pressure in the heating system to drop.

This explains why it is normal that the heating system must be topped up a couple of times after commissioning it. Eventually the system will have to be topped up on average once a year.

Should it be necessary to top up the heating system more frequently, water is probably escaping due to a leakage in the system or a defective expansion vessel. In this case the cause of the water loss must be repaired as soon as possible.

### 10.1.2 Filling the condensate trap with water

- ▶ Fill the condensate trap with water.



Fig. 78 Filling the condensate trap with water

## 10.2 Testing and measuring

### 10.2.1 Checking for gas leaks

Prior to the initial start-up check that the gas supply pipework is gas-tight; this must be confirmed in the commissioning log book.



**DANGER:** Danger of fatal accident from explosive fumes.

Pipes and fittings may leak after commissioning and maintenance activities have been carried out.

- ▶ Carry out a correct leakage test.
- ▶ Only use approved leak detection spray to locate leaks.



**CAUTION:** Damage to the installation due to short circuits

- ▶ Cover any hazardous locations prior to locating the leaks.
- ▶ Do not spray the leak detection product on cable runs, plugs or electrical wiring. Do not let it drip onto them either.

- ▶ Slowly open the gas valve by pushing on the gas valve and turning it  $\frac{1}{4}$  rotation in an anticlockwise direction. The gas valve is open when it is in the vertical position.

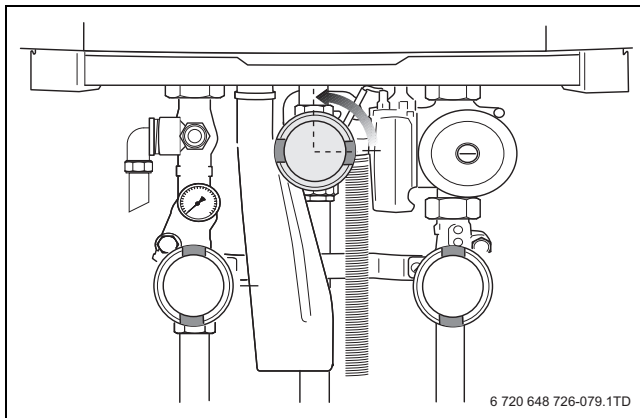

Fig. 79 Open the gas valve

- ▶ Switch off the power supply to the heating system.

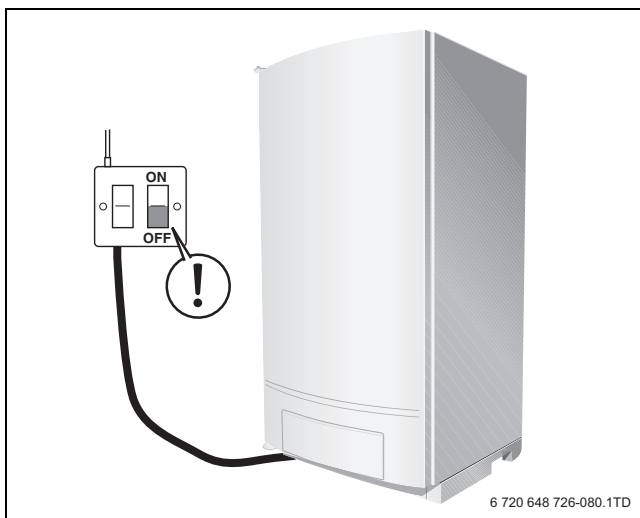

Fig. 80 Switch off the power supply to the heating system

- ▶ Check the new pipe section up to and including its connection (i.e. direct sealing location) to the gas fitting for leaks, using a foaming product. The maximum test pressure allowed at the gas valve inlet is 150 mbar.

### 10.2.2 Bleeding the gas flow pipe

- ▶ Close the gas valve.

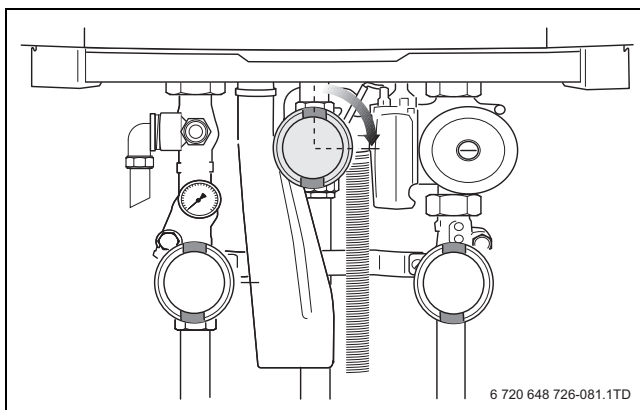

Fig. 81 Closing the gas valve

- ▶ Open the screw plug on the testing nipple of the gas supply pressure and for purging [1] by 2 turns and install a hose.

- ▶ Slowly open the gas valve by pushing on the gas valve and turning it anticlockwise through  $\frac{1}{4}$  rotation ( $\rightarrow$  fig. 85, page 58). The gas valve is open when it is in the vertical position.
- ▶ Purge the gas supply into a well ventilated area.
- ▶ Close the gas shut-off valve when no more air is present (fig. 87).
- ▶ Remove the hose and tighten the screw plug on the testing nipple again.



#### NOTICE:

- ▶ Test the tightness of the measuring nipple(s) used.

### GB162-50/65

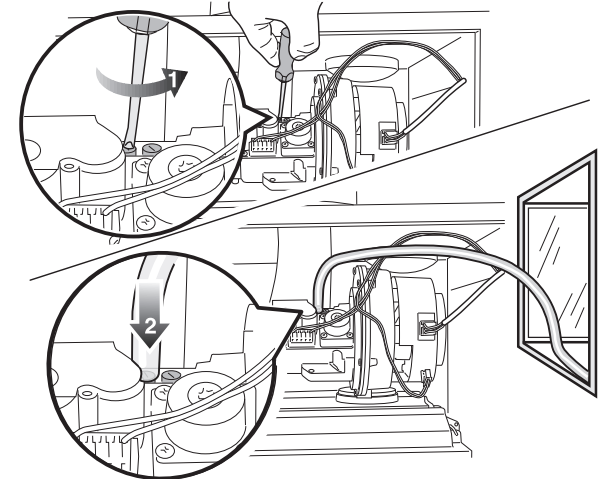

### GB162-80/100

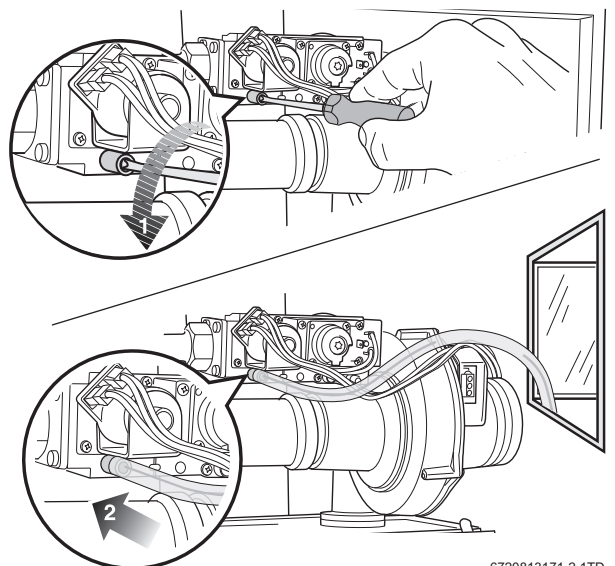

Fig. 82 Bleeding the gas flow pipe

### 10.2.3 Gas consumption test

- ▶ Isolate all other appliances.
- ▶ Set the boiler to full load.
- ▶ Ensure that there is no modulating of the fan gas valve by operating the test mode.
- ▶ Carry out the gas consumption procedure as described in the latest edition of the Essential Gas Safety book.

### 10.2.4 Checking the flue gas connection

Check the following points:

- Has the prescribed flue gas system been used (→ section 8.4 “Flue gas connection”, page 23)?
- Have the configuration instructions from the relevant flue gas system installation instructions been observed?
- Ensure all flue system connections made correctly. Has the annual CO<sub>2</sub> and NO<sub>x</sub> clearance to combustible materials been measured? Have the permissible maximum length limit values from the flue gas system installation instructions been observed?

### 10.2.5 Checking the appliance configuration

The burner must only be put into use with the right injectors (→ table 14).

Boiler	Type of gas supply	Gas injector diameter [mm]
GB162-50	Natural gas H	Venturi <sup>1)</sup>
	LPG 3P	5.3
GB162-65	Natural gas H	Venturi
	LPG 3P	5.3
GB162-80	Natural gas H	8.4
	LPG 3P	4.7
GB162-100	Natural gas H	8.4
	LPG 3P	4.7

Table 14 Gas injector diameter

1) Check the gas classification label on the Venturi.

**NOTICE:**

- ▶ Consult the relevant gas utility company for the type of gas supply.
- ▶ Check that the actual gas supply is in accordance with the type of gas supply specified on the gas classification label (→ fig. 83).

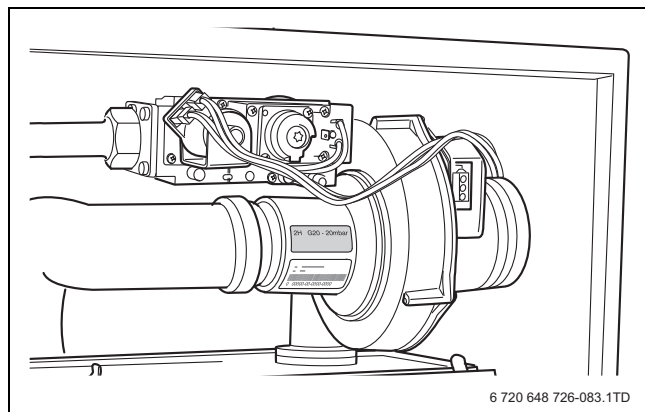

Fig. 83 Checking the gas classification label

Type of gas supply	Factory presetting for the gas burner
Natural gas H	Delivered ready for operation, adjusted to Wobbe index 14.1 kWh/m <sup>3</sup> (with reference to 15 °C, 1013 mbar), applicable to Wobbe index range 12.7 to 15.2 kWh/m <sup>3</sup> . Markings on gas classification label: Configured category: G 20 – 2H.
LPG 3P	After adaptation by a Gas Safe registered installer, the unit can be run on LPG. Markings on gas classification label: Configured category: G 31 – 3P.

Table 15 Factory presetting for the gas burner

### 10.2.6 Measuring the gas inlet pressure (working pressure)

- ▶ Open at least 2 thermostatic radiator valves. Do not switch on the boiler.
- ▶ Push on the control panel to open it (→ fig. 68, page 32).
- ▶ Switch off the power supply to the heating system (→ fig. 90).

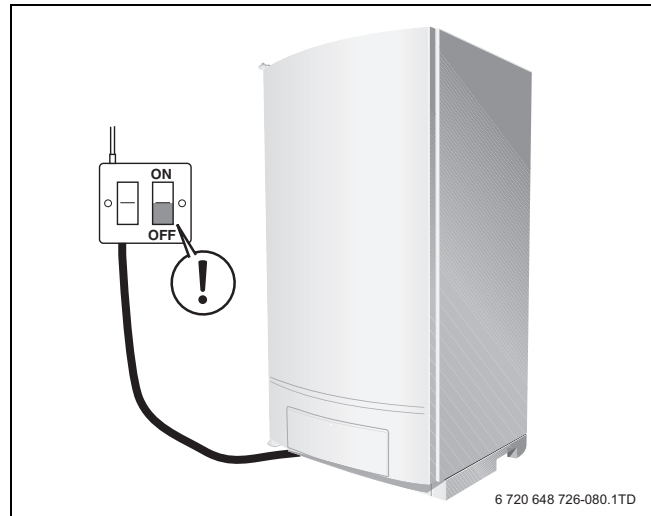

Fig. 84 Switch off the power supply to the heating system

- ▶ Close the gas valve in a clockwise direction (→ fig. 81, page 39).
- ▶ Turn the vent key through a quarter rotation to undo the boiler door lock (→ fig. 71, see detailed picture, page 37).
- ▶ Push the fastener down and open the boiler door (→ fig. 71, page 37).
- ▶ Open the screw plug on the testing nipple for the gas hook-up pressure and for purging by 2 turns [1].
- ▶ Reset the digital pressure gauge to “0”.

**i** Throughout the measuring operation, keep the digital pressure gauge in the same position (horizontal or vertical) in which it was reset to “0”.

- ▶ Connect the pressure gauge connection tube to the positive port of the testing nipple [2].

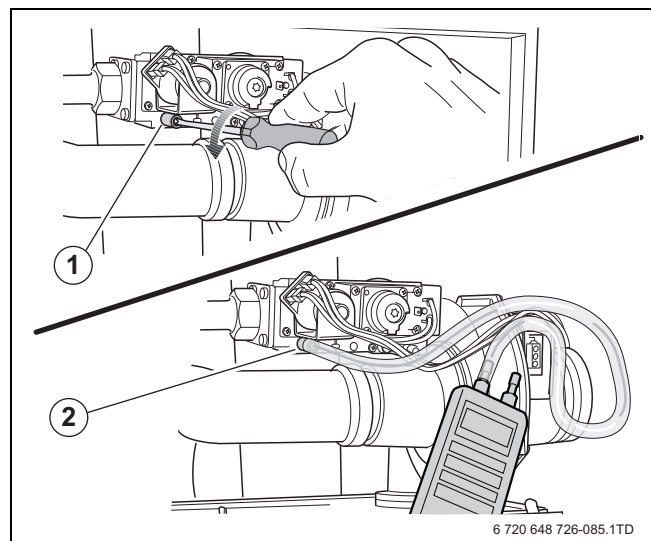

Fig. 85 Measuring the gas supply pressure

- ▶ Slowly open the gas valve by pushing on the gas valve and turning it ¼ rotation in an anticlockwise direction (→ fig. 79, page 39). The gas valve is open when it is in the vertical position.
- ▶ Switch on the heating system by pressing the mains switch [1] of the BC10 basic controller.

- ▶ Press and hold the “Chimney sweep” button [3] (approximately 2 seconds), until the dot in the right-hand bottom corner of the display [9] appears. See also table 10, “Flue gas test”, page 34.
- ▶ After the “Burner” LED [6] has lit up wait for one minute until the boiler is burning at full load.
- ▶ Measure the gas supply pressure and enter it in the commissioning log book, page 72.

The gas supply pressure must be:

- for natural gas H min. 17 mbar, max. 25 mbar, nominal supply pressure 20 mbar.
- for LPG min. 30 mbar, max. 50 mbar, nominal supply pressure 37 mbar.
- ▶ Press the “Service” button [4] repeatedly until the temperature reading is shown in the display.
- ▶ Press the “Chimney sweep” button [3] to clear the reading. Also see table 10, “Flue gas test”, page 50.

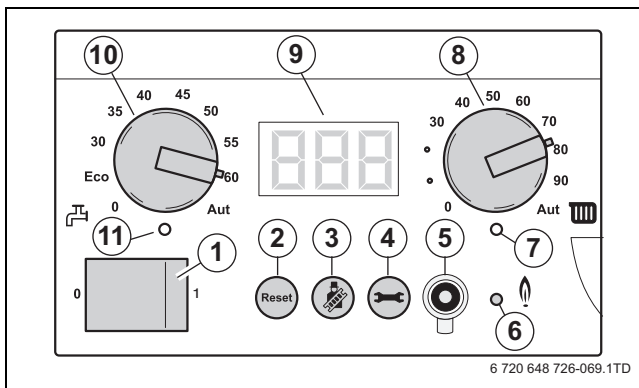

Fig. 86 BC10 basic controller

**DANGER:** Danger of fatal accident from explosive fumes.

- ▶ Check the testing nipples used for leaks.
- ▶ Only use approved leak detection spray to locate leaks.

**NOTICE:**

- ▶ Check the gas supply pipe or contact the relevant gas utility company if the required supply pressure is not available.
- ▶ If the supply pressure is too high, a gas pressure regulator must be integrated upstream of the gas fitting. Contact the gas utility company.

- ▶ Close the gas valve (→ fig. 81, page 39).
- ▶ Remove the gauge-connection tube and tighten the screw plug on the testing nipple again.
- ▶ Open the gas valve again by pushing on the gas valve and turning it ¼ rotation in an anticlockwise direction (→ fig. 79, page 39).

### 10.2.7 Checking and adjusting the gas/air-ratio

**WARNING:** Damage to the boiler by incorrect adjustment of the gas/air-ratio.

- ▶ Adjust gas/air-ratio **only** with part load.
- ▶ Adjust gas/air-ratio **only** based on the gas/air pressure differential and never based on measured flue gas values such as CO/CO<sub>2</sub>/NO<sub>x</sub>.

- ▶ Open at least 2 thermostatic radiator valves. Do not switch on the boiler.
- ▶ Push on the control panel to open it (→ fig. 68, page 32).

- ▶ Switch off the heating system by pressing the mains switch of the BC10 basic controller (→ fig. 86, [1]).
- ▶ Close the gas valve (→ fig. 81, page 39).
- ▶ Turn the vent key through a quarter rotation to undo the boiler door lock (→ fig. 71, see detailed picture, page 37).
- ▶ Push the fastener down and open the boiler door (→ fig. 71, page 37).
- ▶ Open the screw plug on the testing nipple for the burner pressure by 2 turns [1].
- ▶ Set the pressure gauge to “0”.

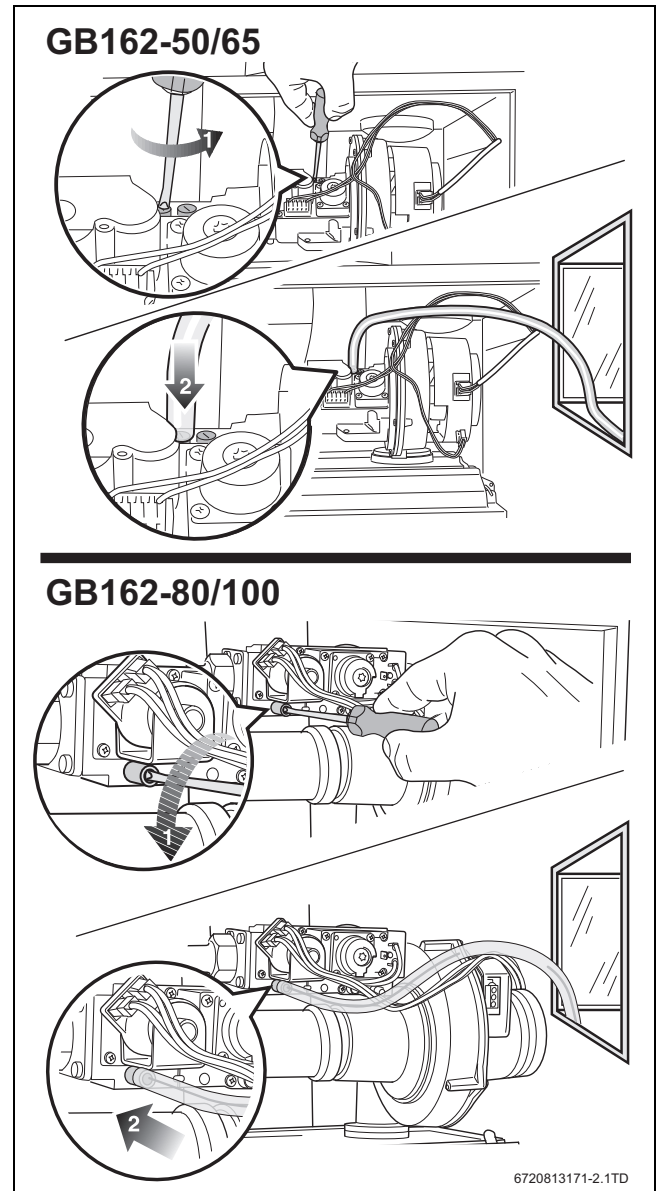

Fig. 87 Checking the gas/air ratio

**i** Throughout the measuring operation, keep the digital pressure gauge in the same position (horizontal or vertical) in which it was reset to “0”.

- ▶ Use a connection tube to connect the positive port of the pressure gauge to the testing nipple for burner pressure (→ fig. 87, [2]).
- ▶ Slowly open the gas valve by pushing on the gas valve and turning it ¼ rotation in an anticlockwise direction (→ fig. 79, page 39).
- ▶ Switch on the heating system by pressing the mains switch of the BC10 basic controller (→ fig. 86, [1]).
- ▶ Activate the Service mode in accordance with the “Service mode” menu (→ table 11, page 34).

- ▶ Set the capacity to minimum (part load) according to the “Service mode” menu (→ table 11, page 34).
- ▶ After the “Burner” LED (→ fig. 86, [6]) has lit up wait for one minute until the boiler is burning at part load.
- ▶ Read the differential pressure during service mode. The differential pressure ( $p_{\text{gas}} - p_{\text{air}}$ ) must be  $-5 \text{ Pa}$  ( $\pm 5 \text{ Pa}$ ) (indication on the pressure gauge:  $-10$  to  $0 \text{ Pa}$ ).

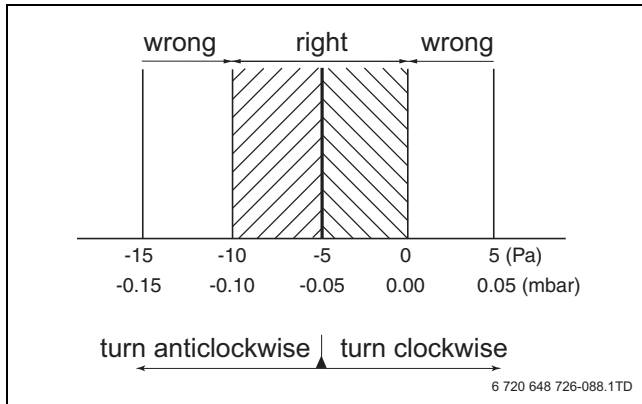

Fig. 88 Gas/air difference at low load

- ▶ Enter the result in the commissioning log book (→ section 10.5 “Commissioning record log book”, page 45).
- ▶ If the gas/air-ratio is incorrect, it must be adjusted on the set screw (Torx 40 H) [1]. The set screw is located behind the screw-on cover.

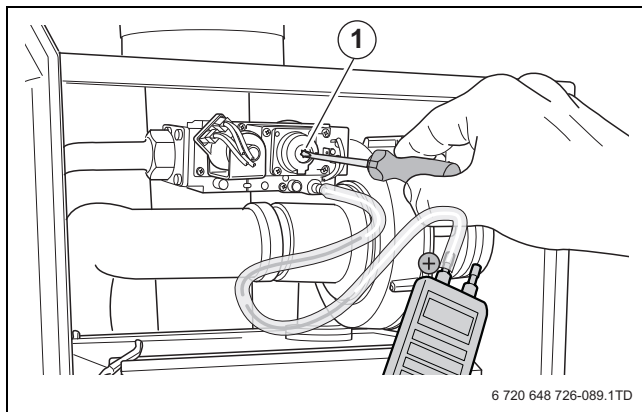

Fig. 89 Gas/air difference at low load

- ▶ Press the “Chimney sweep” button (→ fig. 86, [3]) until the dot disappears from the display.
- ▶ Switch off the heating system by pressing the mains switch of the BC10 basic controller (→ fig. 90, [1]).
- ▶ Close the gas valve (→ fig. 81, page 39).
- ▶ Remove the measuring devices.
- ▶ Tighten the screw in the burner pressure measuring nipple.
- ▶ Slowly open the gas valve by pushing on the gas valve and turning it  $\frac{1}{4}$  rotation in an anticlockwise direction (→ fig. 79, page 39).
- ▶ Switch on the heating system by pressing the mains switch of the BC10 basic controller (→ fig. 90, [1]).
- ▶ Press and hold the “Chimney sweep” button (→ fig. 90, [3]) (approximately 2 seconds), until the dot in the right-hand bottom corner of the display (→ fig. 90, [9]) appears. See also table 10, “Flue gas test”, page 34.
- ▶ After the “Burner” LED (→ fig. 90, [6]) has lit up wait for one minute until the boiler is burning at full load.

**DANGER:** Danger of fatal accident from explosive fumes.

- ▶ Check the testing nipples used for gas tightness.
- ▶ Only use approved leak detection products to locate leaks.

**WARNING:** Damage to the installation due to short circuits.

- ▶ Cover any hazardous locations prior to locating the leaks.
- ▶ Do not spray the leak detection product on cable runs, plugs or electrical wiring. Do not let it drip onto them either.

- ▶ Press the “Chimney sweep” button (→ fig. 90, [3]) to clear the reading. See also table 10, “Flue gas test”, page 34.
- ▶ Check that the boiler performance is still at the required value. See table 13 “Settings”, page 36.

### 10.2.8 Carrying out a leakage test in operating conditions

**DANGER:** Danger of fatal accident from explosive fumes.

Pipes and fittings may leak after commissioning activities have been carried out.

- ▶ Only use approved leak detection products to locate leaks.

- ▶ Press and hold the “Chimney sweep” button [3] (approximately 2 seconds), until the dot in the right-hand bottom corner of the display [9] appears. See also table 10, “Flue gas test”, page 34.
- ▶ After the “Burner” LED [6] has lit up wait for one minute until the boiler is burning at full load.
- ▶ Use a foaming product to check all sealing locations in the total gas circuit of the burner while the burner is active.

**WARNING:** Damage to the installation due to short circuits.

- ▶ Cover any hazardous locations prior to locating the leaks.
- ▶ Do not spray the leak detection product on cable runs, plugs or electrical wiring. Do not let it drip onto them either.

- ▶ Press the “Chimney sweep” button [3] to clear the reading. See also table 10, “Flue gas test”, page 34.

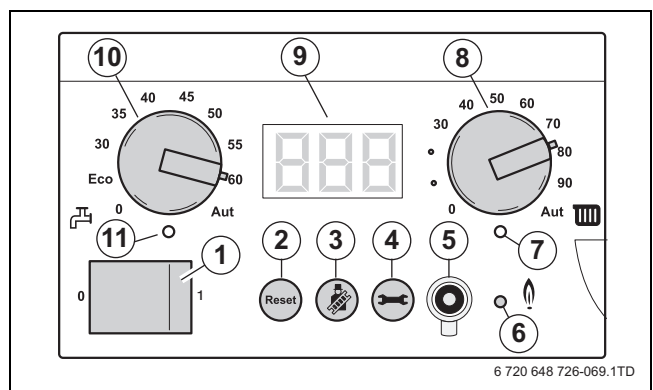

Fig. 90 BC10 basic controller

### 10.2.9 Measuring the flue gases CO<sub>2</sub> emissions

- ▶ Open at least 2 thermostatic radiator valves. Do not switch on the boiler.
- ▶ Push on the control panel to open it (→ fig. 68, page 32).
- ▶ Switch off the heating system by pressing the mains switch of the BC10 basic controller (→ fig. 90, [1]).
- ▶ Remove the cover from the flue gas measuring point [1].
- ▶ Connect the flue gas analyser to the left-hand measuring point.

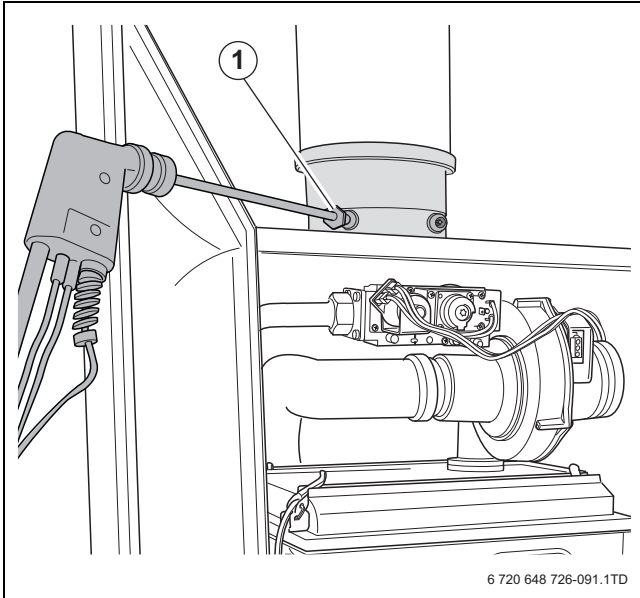

Fig. 91 Measuring the gas supply pressure

- ▶ Switch on the heating system by pressing the mains switch of the BC10 basic controller (→ fig. 90, [1]).
- ▶ Press and hold the “Chimney sweep” button (→ fig. 90, [3]) (approximately 2 seconds), until the dot in the right-hand bottom corner of the display (→ fig. 90, [9]) appears. See also table 10, “Flue gas test”, page 34.
- ▶ After the “Burner” LED (→ fig. 90, [6]) has lit up wait for one minute until the boiler is burning at full load.
- ▶ Measure the carbon monoxide content at the flue gas measuring point (→ fig. 91).

The CO values in air-free condition must be less than 400 ppm or 0.04 vol. %. Values of 400 ppm or more indicate an incorrect burner adjustment (→ section 10.2.7, page 41), a dirty gas burner or heat exchanger or burner faults.

- ▶ You must determine and remove the cause (→ chapter 12, page 46).
- ▶ Press the “Chimney sweep” button (→ fig. 90, [3]) to clear the reading. See also table 10, “Flue gas test”, page 34.
- ▶ Switch off the heating system by pressing the mains switch of the BC10 basic controller (→ fig. 90, [1]).
- ▶ Remove the flue gas analyser and fit the cover back onto the flue gas measuring point (→ fig. 91, [1]).
- ▶ Switch on the heating system by pressing the mains switch of the BC10 basic controller (→ fig. 90, [1]).
- ▶ Press on the control panel to close it (→ fig. 95, page 45).

### 10.2.10 Carrying out a function test

- ▶ During initial start-up and annual inspection and/or needs-oriented servicing, make sure that all control, regulating and safety devices are in full working order and, if applicable, check them for correct adjustment.
- ▶ The gas and water circuits must be tested for leaks (→ sections 10.2.1 and 10.2.8).

### 10.2.11 Measuring the ionisation current

- ▶ Push on the control panel to open it (→ fig. 68, page 32).
- ▶ Open at least 2 thermostatic radiator valves. Do not switch on the boiler.
- ▶ Switch off the heating system by pressing the mains switch of the BC10 basic controller (→ fig. 90, [1]).
- ▶ Turn the vent key through a quarter rotation to undo the boiler door lock (→ fig. 71, see detailed picture, page 37).
- ▶ Push the fastener down and open the boiler door (→ fig. 71, page 37).
- ▶ Undo the plug and socket connection of the monitoring cable.

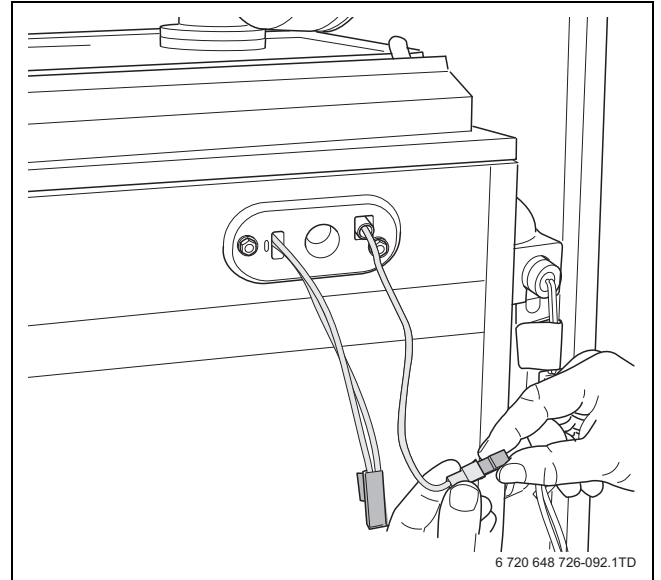

Fig. 92 Removing the ionisation electrode plug and socket connection

- ▶ Connect the multimeter in series. Select the  $\mu\text{A}$  DC range on the multimeter. The multimeter must have a resolution of at least 1  $\mu\text{A}$ .

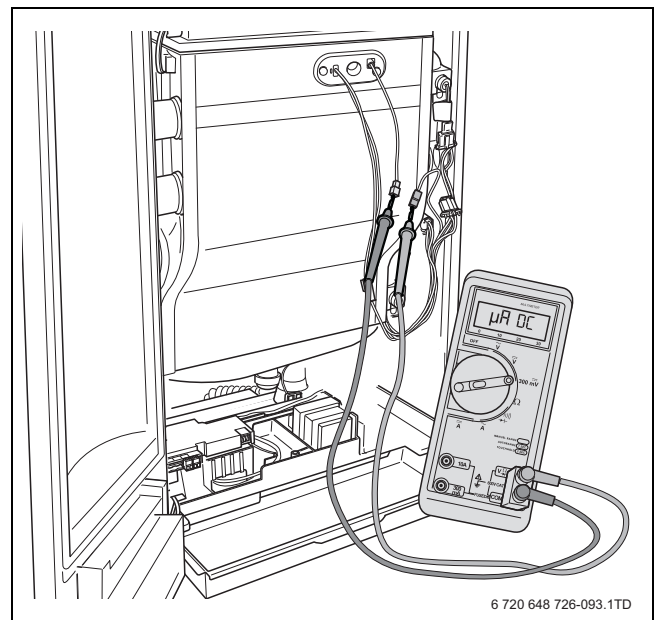

Fig. 93 Measuring the ionisation current

- ▶ Switch on the heating system by pressing the mains switch of the BC10 basic controller (→ fig. 90, [1]).
- ▶ Activate the Service mode in accordance with the “Service mode” menu (→ table 11, page 34).
- ▶ Set the capacity to minimum (part load) according to the “Service mode” menu (→ table 11, page 34).
- ▶ After the “Burner” LED (→ fig. 90, [6]) has lit up wait for one minute until the boiler is burning at part load.

- ▶ Measure the ionisation current. The ionisation current must be > 5 µA DC at part load operation.
- ▶ Enter the result in the commissioning log book (→ section 10.5 “Commissioning record log book”, page 45).
- ▶ If the result is not as it should be, check the gas/air ratio (→ section 10.2.7, page 41) or check the ionisation electrode (→ section 13.2.4, page 50).
- ▶ Press and hold the “Chimney sweep” button (→ fig. 90, [3]) (approximately 2 seconds), until the dot in the right-hand bottom corner of the display (→ fig. 90, [9]) appears. See also table 10, “Flue gas test”, page 34.
- ▶ Switch off the heating system by pressing the mains switch of the BC10 basic controller → fig. 90, [1]).
- ▶ Remove the multimeter and reconnect the monitoring cable.
- ▶ Switch on the heating system by pressing the mains switch of the BC10 basic controller (→ fig. 90, [1]).
- ▶ Check that the boiler performance is still at the required value. See the “Service mode” menu (→ table 11, page 34).

### 10.3 Boiler settings

#### 10.3.1 Setting the heating capacity

- ▶ Set the required heating capacity on the BC10 according to the “Settings” menu (→ table 13, page 36). See table 16 when making these settings.

Display indication [%]	Rated heating capacity at 40/30 °C [kW]			
	GB162-50	GB162-65	GB162-80	GB162-100
L20	–	15.6	–	21.1
L25	–	18.7	21.1	26.0
L30	15.6	21.8	25.3	30.9
L35	18.1	24.9	29.6	35.8
L40	20.5	28.0	33.8	40.7
L45	23.0	31.1	38.0	45.8
L50	25.4	34.2	42.2	50.5
L55	27.9	37.3	46.5	55.4
L60	30.3	40.4	50.7	60.3
L65	32.8	43.5	54.9	65.2
L70	35.2	46.6	59.1	70.1
L75	37.7	49.7	63.4	75.0
L80	40.1	52.8 <sup>(1)</sup> 50	67.6	79.9
L85	42.6	55.9 <sup>(1)</sup> 50	71.8	84.8
L90	45.0	59.0 <sup>(1)</sup> 50	76.0	89.7
L95	47.5	62.1 <sup>(1)</sup> 50	80.3	94.6
L--	49.9	65.2 <sup>(1)</sup> 50	84.5	99.5

Table 16 Heating capacity in kW (as a percentage)

1) Capacity at BC10 basic controller with removed jumper.

#### 10.3.2 Setting the maximum CH flow temperature

- ▶ Set the upper CH flow temperature limit for heating mode (→ table 17) using the “Maximum CH flow temperature” dial (→ fig. 97, [8]).

**WARNING:** Damage to the installation due to overheating the floor slab when using an underfloor heating system.

The setting at the BC10 cannot be adjusted via the menu but must instead be set via the “Maximum CH flow temperature” dial (→ fig. 97, [8]).

- ▶ Limit the maximum CH flow temperature in the “Settings” menu (in most cases 45 °C).
- ▶ Observe that the underfloor heating system must be equipped with a safety limiter, e.g. via the external switching contact (→ page 28).

This limit value does not apply to DHW mode.

Dial position	Explanation
0	No supply to radiators (e.g. only DHW mode)
30 – 90	The temperature is set permanently on the BC10 and cannot be changed with a room controller (e.g. RC35).
Aut	The temperature is determined automatically on the basis of the heating curve. If no room controller is connected, 90 °C is the maximum CH (boiler) flow temperature.

Table 17 Setting of “Maximum CH (boiler) flow temperature” dial

#### 10.3.3 Setting the pump run-over time

Set the pump run-over time to 24 hours if the heating system is controlled depending on room temperature, and there is a risk of parts of the heating system not controlled by the room controller freezing (e.g. radiators in the garage).

- ▶ Set the pump run-over time according to the “Settings” menu (→ table 13, page 36).

#### 10.3.4 Switching DHW mode on/off



If this setting  is seen, it switches off the frost protection for the hot water cylinder (if present).

- ▶ Set the DHW mode according to the “Settings” menu (→ table 13, page 36).

#### 10.3.5 Setting the DHW temperature

- ▶ Set the DHW temperature dial (→ fig. 90, [10]) to the required temperature of the hot water in the hot water cylinder (→ table 18).

Dial position	Explanation	Legionella information
0	DHW mode is off (if applicable only heating mode)	There is no risk of legionella contamination
ECO	Do not use this setting!	
30 – 45	DHW temperature in °C	The risk is very low if the DHW mode is used every day.
45 – 60	DHW temperature in °C	There is no risk of legionella contamination. This position is recommended.
Aut	DHW temperature is 60 °C	There is no risk of legionella contamination

Table 18 Settings on the DHW temperature dial

**10.4 Final activities**

**10.4.1 Closing the boiler door and the control panel**

- ▶ Close the boiler door and lock the fastener by turning the vent screw through ¼ rotation in a clockwise direction.

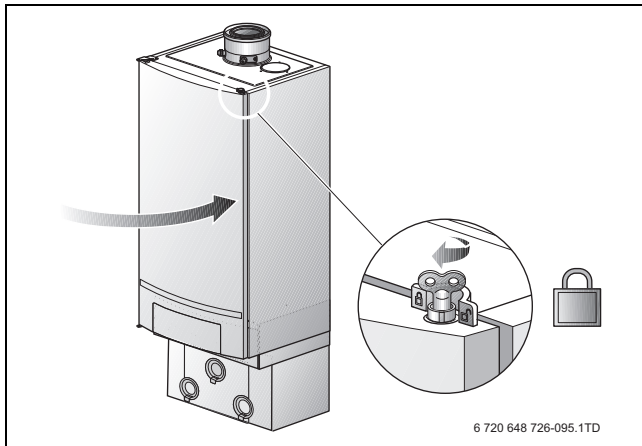

Fig. 94 Closing the boiler door

- ▶ Push on the control panel to close it.

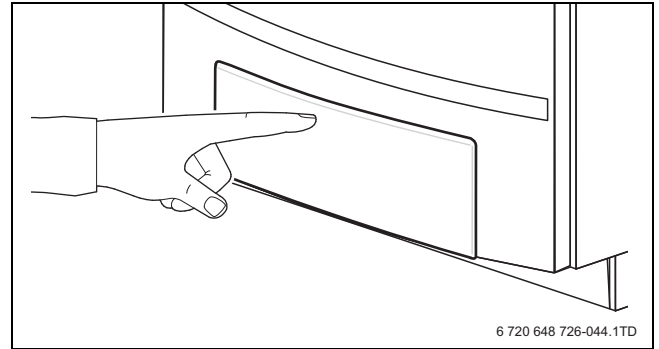

Fig. 95 Closing the control panel

**10.4.2 Handing over**

After completing the installation and commissioning of the system the installer should hand over to the end user by the following actions.

- ▶ Hand over all relevant documentation to the end user and explain his/her responsibilities under the relevant national and regional regulations.
- ▶ Explain and demonstrate the starting and shutting down procedures.

**NOTICE:**

- ▶ During initial start-up and annual servicing, make sure that all control, regulating and safety devices are in full working order and, if applicable, check for correct adjustment.
- ▶ Always keep the user manual and installation and servicing instructions by the boiler.

**10.5 Commissioning record log book**

- ▶ Enter your signature and the date after completing the start-up activities.

Start-up activities		Page	Measurement results	Remarks
1.	Filling and pressure testing the heating system.		<input type="checkbox"/>	
	<ul style="list-style-type: none"> <li>• Pre-pressure expansion vessel (refer to the installation instructions for the expansion vessel)</li> <li>• Heating system filling pressure</li> </ul>	37	_____bar	
2.	Write down the gas characteristics: Wobbe-index		_____kWh/m <sup>3</sup>	
	Operating heat value		_____kWh/m <sup>3</sup>	
3.	Checking for gas leaks	38	<input type="checkbox"/>	
4.	Bleeding the gas flow pipe	39	<input type="checkbox"/>	
5.	Checking the flue gas connection	40	<input type="checkbox"/>	
6.	Checking the appliance configuration	40	<input type="checkbox"/>	
7.	Measuring the gas supply pressure (working pressure)	40	_____mbar	
8.	Checking and adjusting the gas/air ratio	40	_____Pa/mbar	
9.	Carrying out a leakage check in operating conditions	42		
10.	Measuring the carbon monoxide content (CO), air free	43		
11.	Function testing	43	<input type="checkbox"/>	
	Measure the ionisation current	43	_____µA	
12.	Boiler settings	44	<input type="checkbox"/>	
13.	Closing and locking the boiler door	45	<input type="checkbox"/>	
14.	Informing the user, handing over technical documents	45	<input type="checkbox"/>	

Confirming proper commissioning

**Company stamp/signature/date**

Table 19

## 11 Shutting down the heating system

### 11.1 Shutting down the heating system using the basic controller

Shut down your heating system by means of the BC10 basic controller. When the system is shut down, the burner is automatically switched off.

Further information about the use of the BC10 basic controller is provided in chapter 9 "Operation", page 32.

- ▶ Push on the control panel to open it.

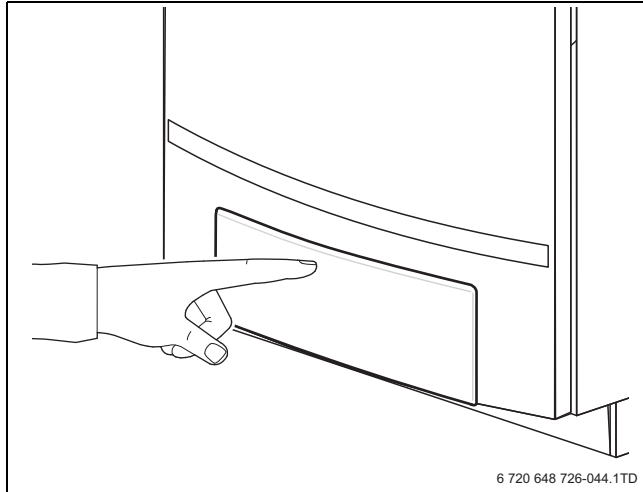

Fig. 96 Opening the control panel

- ▶ Switch off the heating system by pressing the mains switch of the BC10 [1].

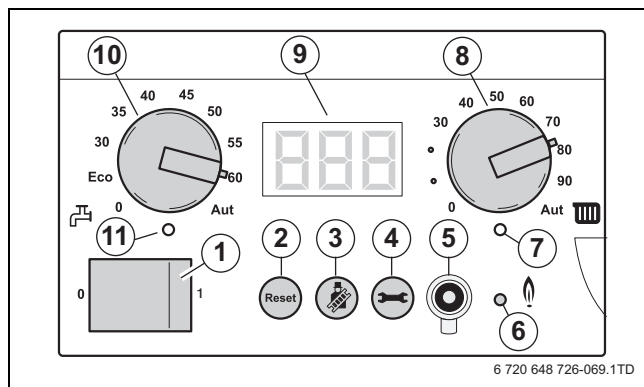

Fig. 97 BC10 basic controller

- ▶ Close the main gas supply or the gas valve (→ fig. 81, page 39).

### 11.2 Shutting down the heating system if there is a risk of freezing (interruption of use)

**WARNING:** Damage to the installation due to freezing. The heating system may freeze up after some time in certain situations, e.g. after a power failure, when the supply voltage has been switched off, in case of faulty gas supply, a boiler fault etc.

- ▶ Ensure that the heating system is permanently operational (especially if there is a risk of freezing).

If conditions are such that the heating system has to be shut down for a long period while there is a risk of freezing, the water must be drained from the heating system.

- ▶ Push on the control panel to open it.
- ▶ Switch off the heating system by pressing the mains switch of the BC10 [1].

- ▶ Close the main gas supply or the gas valve (→ fig. 81, page 39).
- ▶ Drain the heating water at the lowest point of the heating system, using the drain cock or the radiator. The (automatic) air vent at the highest point of the heating system/radiator must be open.

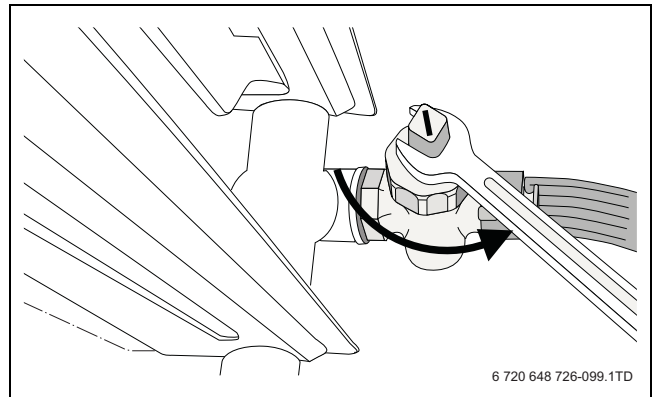

Fig. 98 Draining the heating system

## 12 Inspection

- ▶ The activities to be included in an annual inspection and maintenance contract can be found in the inspection and service record log book (→ pages 48 and 52).

**WARNING:** Damage to the installation due to insufficient or improper cleaning and maintenance.

- ▶ Inspect and clean the heating system once a year.
- ▶ Carry out maintenance as required. Immediately remedy faults. This will avoid further damage to the system.

### 12.1 Preparing the heating system for inspection

**DANGER:** Danger of fatal accident due to electric current when the boiler is on.

- ▶ Before opening the boiler: Switch off the power supply to the boiler by isolating the supply and removing the fuse.
- ▶ Secure the heating system so that it cannot be switched on again unexpectedly.

- ▶ Switch off the power supply to the heating system.

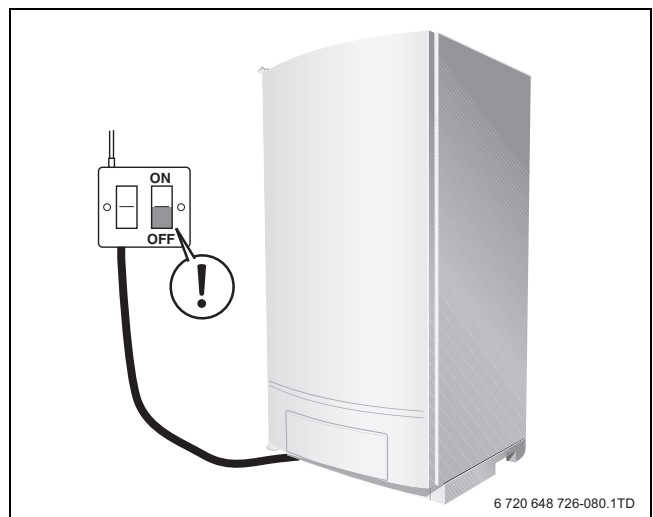

Fig. 99 Switch off the power supply to the heating system

**! DANGER:**  
Danger of fatal accident from explosive fumes.

- ▶ Only carry out work on gas pipes and fittings if you are Gas Safe / ACS registered.

- ▶ Close the gas valve [1].
- ▶ Close the isolating valves [2].

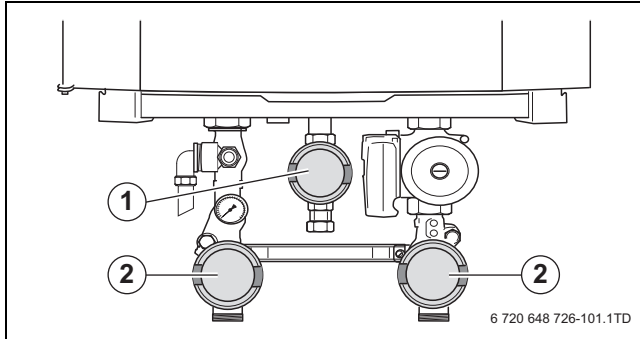

Fig. 100 Closing the valves (here: in closed position)

### 12.2 Opening the boiler door

- ▶ Turn the vent key through a quarter rotation to undo the boiler door lock (→ detailed picture).
- ▶ Push the fastener down and open the boiler door.

**i** If the boiler door cannot be swung open completely, remove it (→ section 13.1 “Removing the boiler door”, page 48).

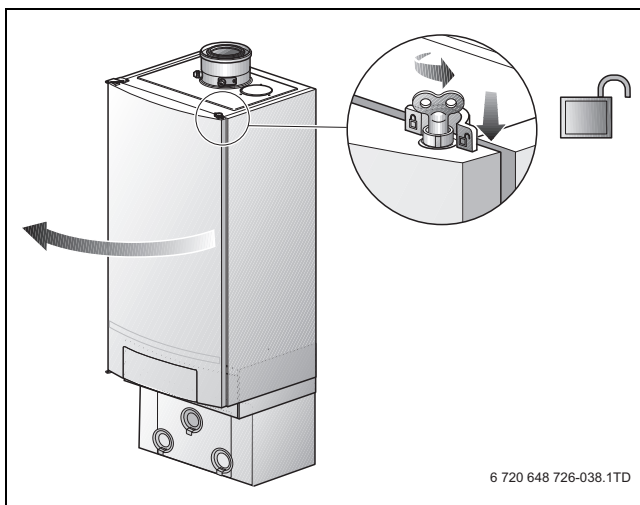

Fig. 101 Opening the boiler door

### 12.3 Carry out a visual check for general signs of corrosion

- ▶ Check all gas and water-bearing pipes for signs of corrosion and for leaks.
- ▶ Replace any pipes that have corroded.
- ▶ Carry out a visual inspection of the burner, heat exchanger, condensate trap, automatic air vent and all fittings in the boiler.

### 12.4 Gas valve leakage test

Check the internal tightness of the gas fitting on the input side (with the boiler switched off) at a test pressure of 20 mbar for natural gas.

- ▶ Open the screw plug on the testing nipple for the gas connection by 2 turns.
- ▶ Connect the pressure gauge tube to the testing nipple. The pressure drop allowed after one minute is max. 10 mbar.
- ▶ If the pressure drop is higher, check all sealing locations of the gas fitting for leaks using a foaming product. Repeat the pressure test if no leaks are found. Replace the gas fitting if the pressure drop is higher than 10 mbar per minute again (→ section 13.2.1 “Removing the gas valve” on page 49 for instructions on how to remove).

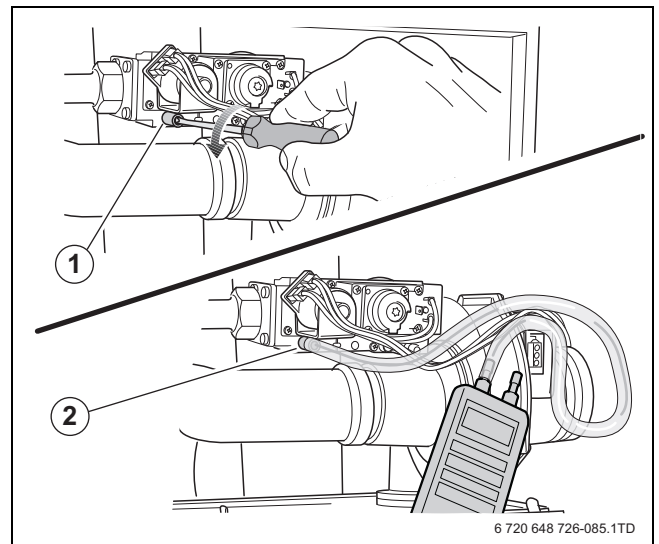

Fig. 102 Checking the gas fitting for internal tightness

### 12.5 Measuring the ionisation current

See section 10.2.11 “Measuring the ionisation current”, page 43.

### 12.6 Measuring the gas inlet pressure (working pressure)

See section 10.2.6 “Measuring the gas inlet pressure (working pressure)”, page 40.

### 12.7 Checking and adjusting the gas/air-ratio

See section 10.2.7 “Checking and adjusting the gas/air-ratio”, page 41.

### 12.8 Carrying out a leakage test in operating conditions

See section 10.2.8 “Carrying out a leakage test in operating conditions”, page 42.

### 12.9 Measuring the flue gases CO<sub>2</sub> emissions

See section 10.2.9 “Measuring the flue gases CO<sub>2</sub> emissions”, page 43.

### 12.10 Filling the heating system

See section 10.1 “Filling the heating system”, page 37.

### 12.11 Checking the flue gas connection

See section 10.2.4 “Checking the flue gas connection”, page 40.

### 12.12 Inspection log book

► Enter your signature and the date after completing the inspection activities.

Inspection activities		Date: _____	Date: _____	Date: _____
1.	Checking the general condition of the heating system.	<input type="checkbox"/>	<input type="checkbox"/>	<input type="checkbox"/>
2.	Carrying out a visual inspection and function test of the heating system.	<input type="checkbox"/>	<input type="checkbox"/>	<input type="checkbox"/>
3.	Checking the gas and water-bearing system components for: • Operational tightness • Visible corrosion • Signs of wear.	Section 10.2.8, page 42. Section 12.3, page 47.	<input type="checkbox"/>	<input type="checkbox"/>
4.	Measuring the ionisation current.	Section 10.2.11, page 43.	_____ $\mu$ A	_____ $\mu$ A
5.	Measuring the gas supply pressure (working pressure).	Section 10.2.6, page 40.	_____ mbar	_____ mbar
6.	Checking the gas/air-ratio.	Section 10.2.7, page 40.	_____ Pa	_____ Pa
7.	Carrying out a tightness check of the gas circuit in operating conditions.	Section 10.2.8, page 42.	<input type="checkbox"/>	<input type="checkbox"/>
8.	Measuring the carbon monoxide content (CO), air free.	Section 10.2.9, page 43.	_____ ppm	_____ ppm
9.	Checking the system pressure. • Pre-pressure of expansion vessel (also see installation instructions for expansion vessel) • Filling pressure.	Section 10.1, page 37.	<input type="checkbox"/>	<input type="checkbox"/>
			_____ bar	_____ bar
			_____ bar	_____ bar
10.	Checking the operation and safety of the air intake and flue gas pipe.	Section 10.2.4, page 40.	<input type="checkbox"/>	<input type="checkbox"/>
11.	Checking the boiler settings of the control device (in accordance with requirements).	See the documents for the control device.	<input type="checkbox"/>	<input type="checkbox"/>
12.	Final check of the inspection activities, documenting the measurement and test results.		<input type="checkbox"/>	<input type="checkbox"/>

13. Confirming proper inspection.

\_\_\_\_\_  
Company stamp/  
signature/date

\_\_\_\_\_  
Company stamp/  
signature/date

\_\_\_\_\_  
Company stamp/  
signature/date

Table 20

## 13 Maintenance

► Prepare the system for maintenance as described in the chapter on Inspection (→ section 12.1, page 46).

### 13.1 Removing the boiler door

If the boiler door cannot be fully opened, it may be necessary to remove the door for inspection and maintenance activities.

Proceed as follows:

- Unscrew the control panel from the boiler door and hang it on the boiler frame (→ fig. 119 “Undoing the screws”, page 53).
- Unscrew the bolt from the left-hand top hinge of the boiler door and remove it together with the washer.
- Slightly lift the door and pull it from the hinge. Put the door upright in a safe position and make sure that it cannot fall over.



The cover over the electrical connections does not have to be removed from the boiler.

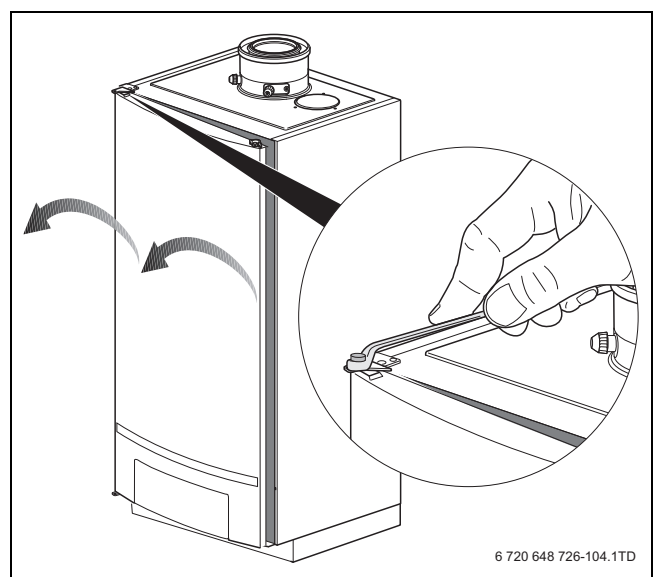



Fig. 103 Removing the boiler door

### 13.2 Cleaning the heat exchanger, burner and condensate trap

The boiler has a self-cleaning coating.



**WARNING:** Damage to the installation due to short circuits.

- ▶ Do not spray the detergent onto the burner, the glow ignitor, the ionisation electrode or other electrical components.

#### 13.2.1 Removing the gas valve

- ▶ Undo the gas fitting screw connection [1] and pull the 4 connectors [2] from the gas valve.

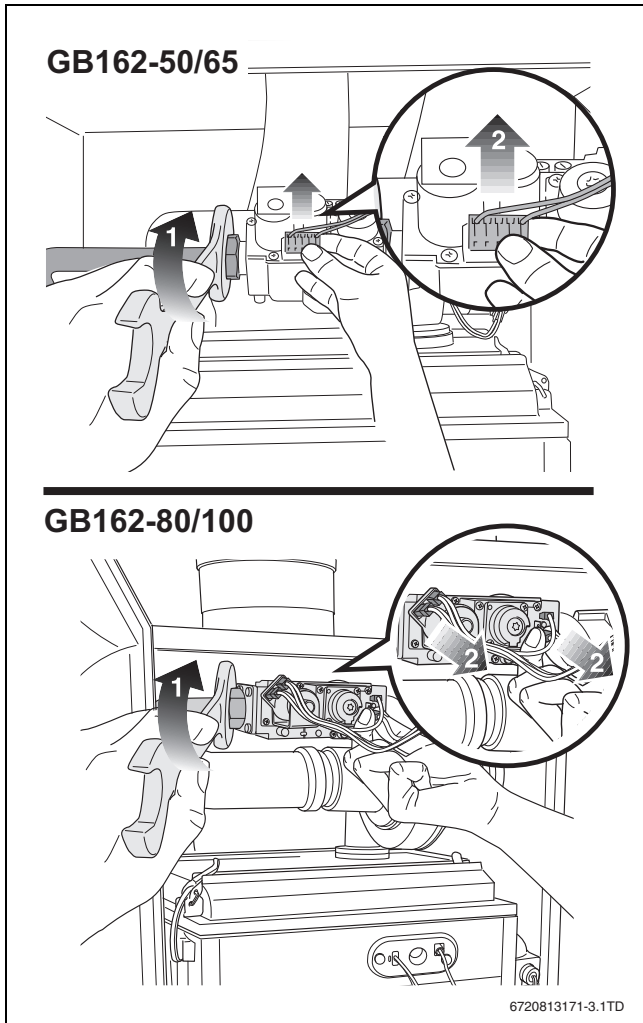

Fig. 104 Undoing the connections to the gas fitting

#### 13.2.2 Removing the burner cover with the fan and the gas valve

- ▶ Pull the mains connector [1] from the fan.
- ▶ Pull the connector of the harness [2] from the fan while pushing on the connector lock to loosen it.

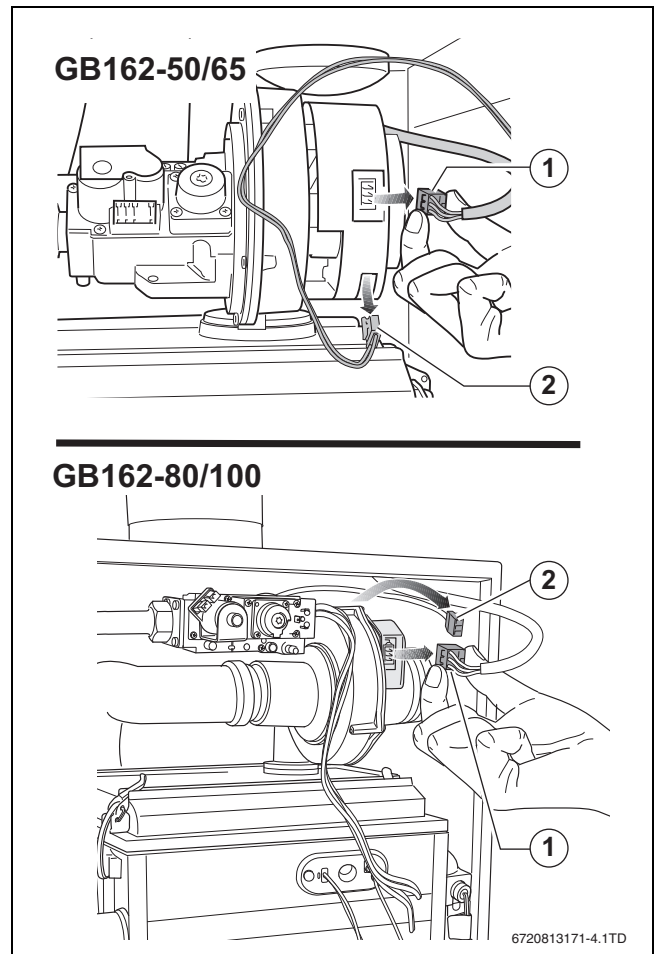

Fig. 105 Undoing the connections to the gas fitting

- ▶ Pull the air suction tube from the fan.

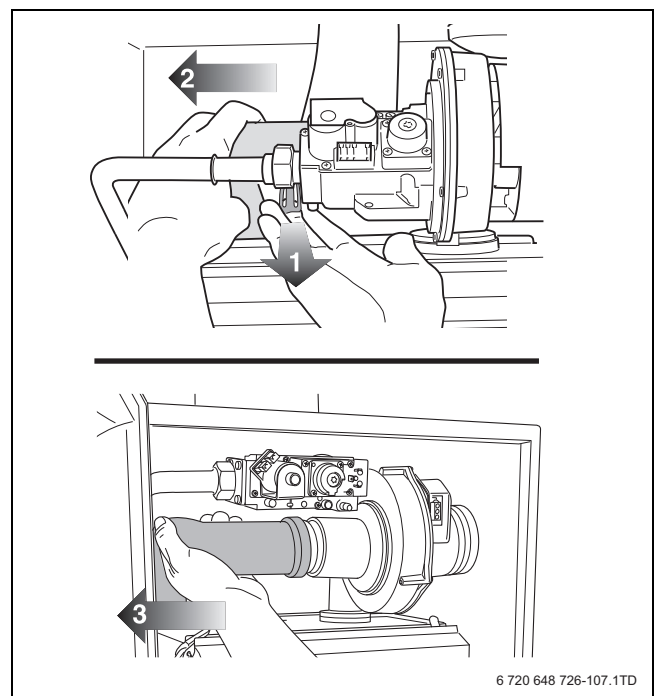

Fig. 106 Pulling the air suction tube from the fan

- ▶ Carefully open the 4 snap closures on the burner cover. The snap closures may be under tension.
- ▶ Remove the snap closures.

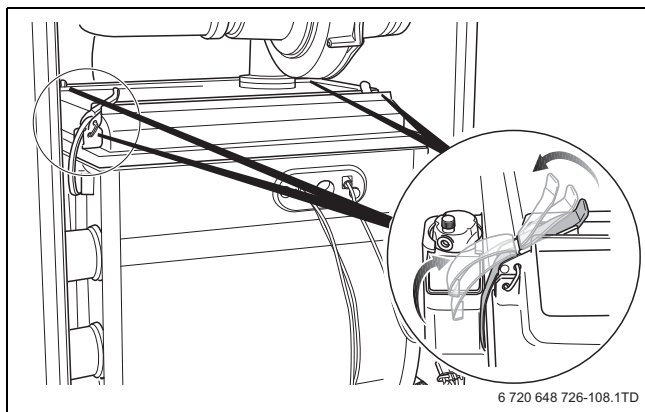

Fig. 107 Opening the snap closures

- ▶ Remove the burner cover with the gas/air unit.

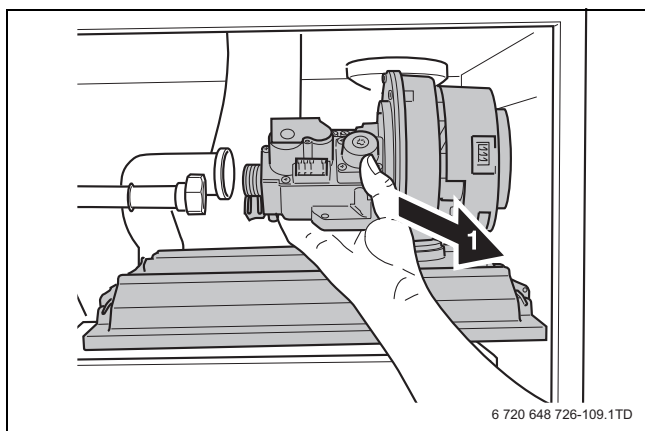

Fig. 108 Removing the burner cover with the gas/air unit

### 13.2.3 Removing the burner and the burner seal

- ▶ Remove the burner seal [1] and replace it if necessary.
- ▶ Remove the burner plate [2] and clean it on all sides using compressed air or a soft brush.

When re-installing the burner plate make sure that the notch is on the right-hand side (→ detailed picture).

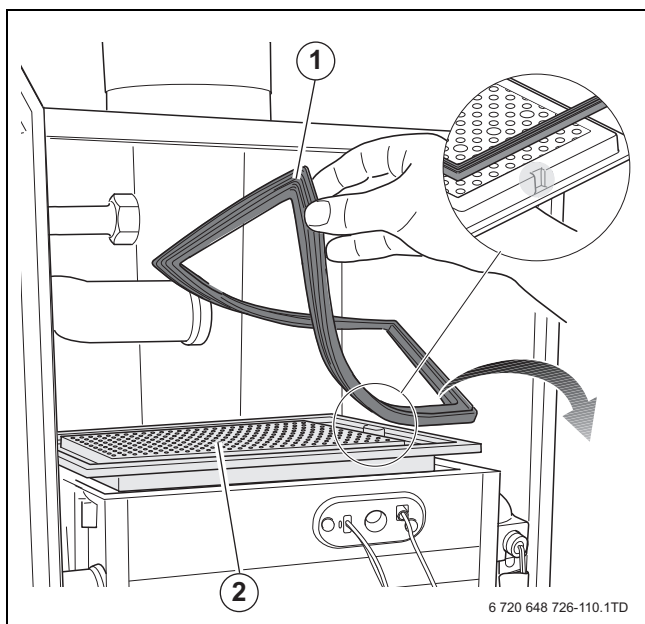

Fig. 109 Removing the burner plate and the burner seal

### 13.2.4 Checking ignition unit



**CAUTION:** Damage to the glow ignitor.

- ▶ The glow ignitor is fragile. Handle with care.



**NOTICE:**

If the seat of the cover plate leaks, the seal can burn away.

- ▶ Check the cover plate for tightness.



**DANGER:**

▶ Close the gas valve prior to working on components in contact with gas.

- ▶ Check for gas tightness after carrying out work on components in contact with gas.



**NOTICE:** Device damage.

Since the effectiveness of the gaskets in the ignition device is reduced, the gas condensing boiler may become damaged.

- ▶ The rubber seal (→ fig. 111, [3]) and the cover plate with seal (→ fig. 111, [4]) need to be replaced every 4 years.

- ▶ Check the individual components of the ignition unit (→ fig. 111) for wear or contamination (→ fig. 110).
- ▶ If required, replace the ionisation electrode and/or glow ignitor.

After checking or replacing the ionisation electrode and/or the glow ignitor fit a new cover plate and rubber seal.

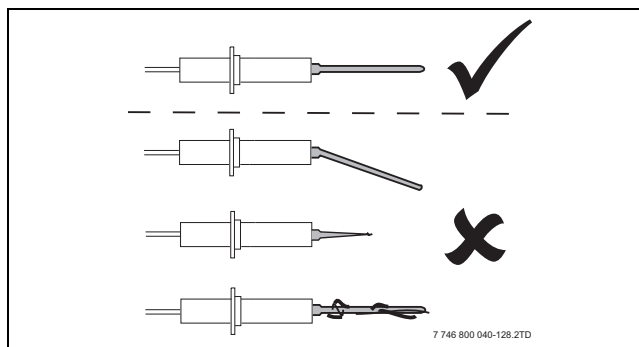

Fig. 110 Checking the ionisation electrode

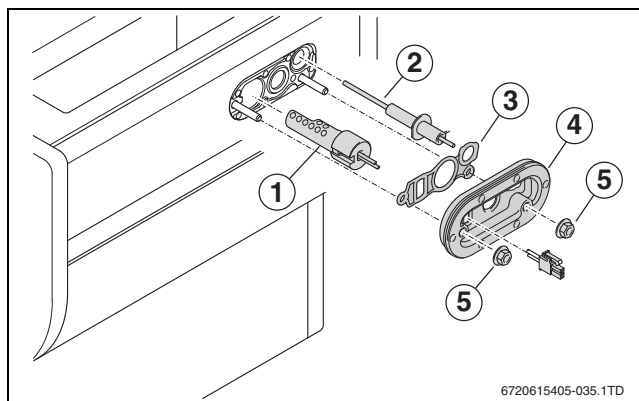

Fig. 111 Replacing the ignition unit

- [1] Glow ignitor
- [2] Ionisation electrode
- [3] Rubber seal
- [4] Cover plate with seal
- [5] Nut

### 13.2.5 Disconnecting the condensate trap

- ▶ Disconnect the condensate trap hose [3] and the rubber sleeve [2] from the condensate trap [1].
- ▶ Turn the trap clockwise a quarter turn.

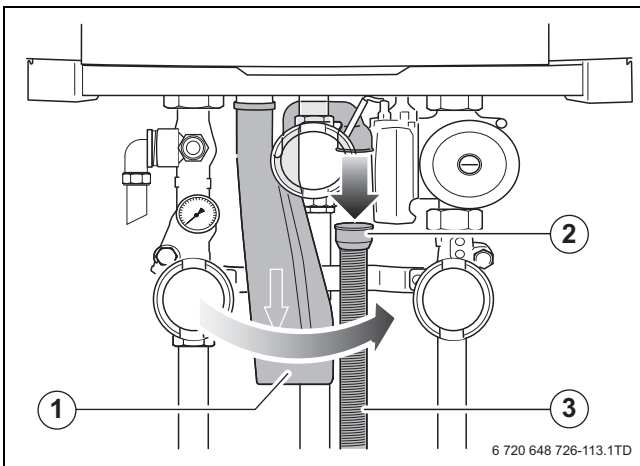

Fig. 112 Disconnecting the condensate trap hose

- [1] Condensate trap
- [2] Rubber sleeve
- [3] Condensate trap hose

- ▶ Disconnect the condensate trap from the coupling and remove it [1].

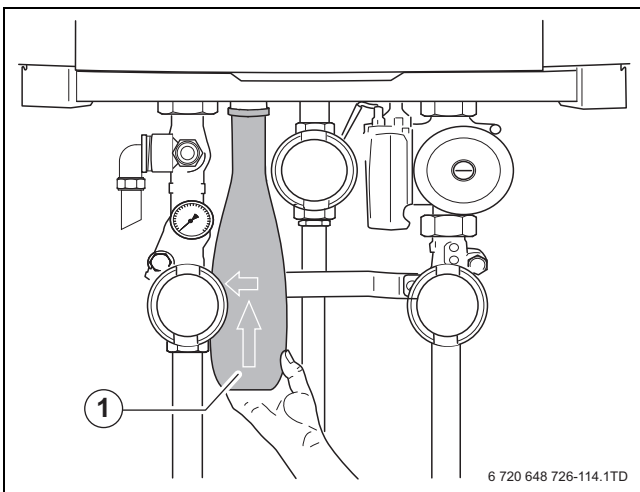

Fig. 113 Disconnecting the condensate trap in the pump group

- ▶ Rinse the condensate trap to clean it.
- ▶ Fill the condensate trap with approximately 1.0 l. water before refitting it.



The condensate trap has a bayonet connector. After inserting it, the condensate trap must be turned clockwise through  $\frac{1}{4}$  rotation until it clicks into place (→ fig. 17, page 17).

### 13.2.6 Removing the condensate collector

- ▶ Disconnect the flexible condensate drain hose and bend it backwards.

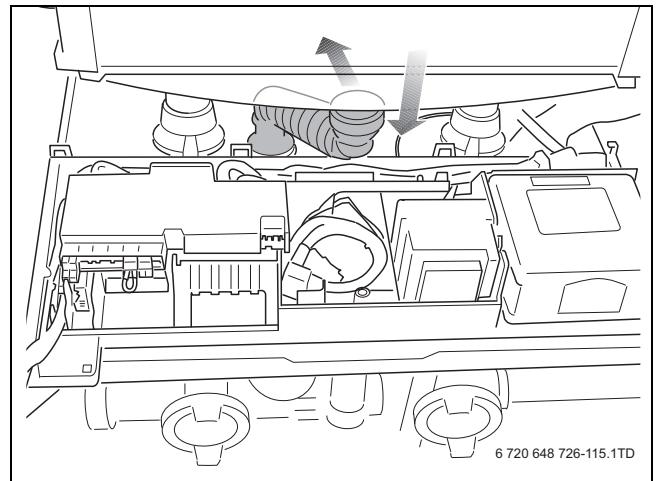

Fig. 114 Removing the condensate trap hose

- ▶ Open the 2 clamps on the right and left at the bottom of the condensate collector [1].
- ▶ Pull the condensate collector down (step 1) and remove it by pulling it towards you (step 2).

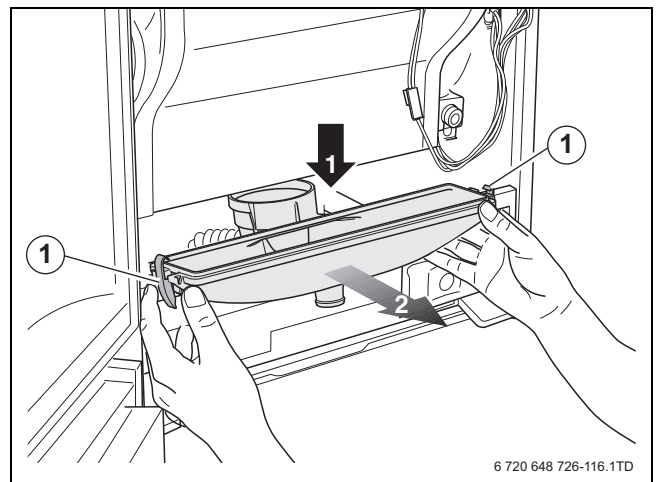

Fig. 115 Removing the condensate collector

- ▶ Check the condensate collector for damage and replace it if required.
- ▶ Clean the condensate collector mechanically (using compressed air or a soft brush) and rinse it with clean water.

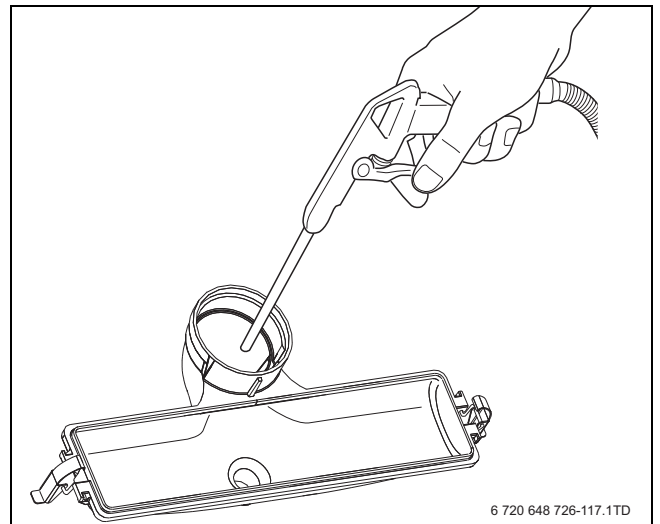

Fig. 116 Cleaning the condensate collector

### 13.2.7 Cleaning the heat exchanger

**CAUTION:** Damage to the installation.

- ▶ Do not use metal brushes or similar hard cleaning tools.

**CAUTION:** Damage to the installation due to faulty glow ignitor.

The glow ignitor is made from fragile ceramic material.

- ▶ Do not damage the glow ignitor.

▶ Check the bottom and top sides of the heat exchanger for dirt.

**CAUTION:** Damage to the installation due to dirt particles.

- ▶ Cover up the boiler interior, e. g. using a blanket or a cover.

▶ Clean the heat exchanger with compressed air or a soft brush.

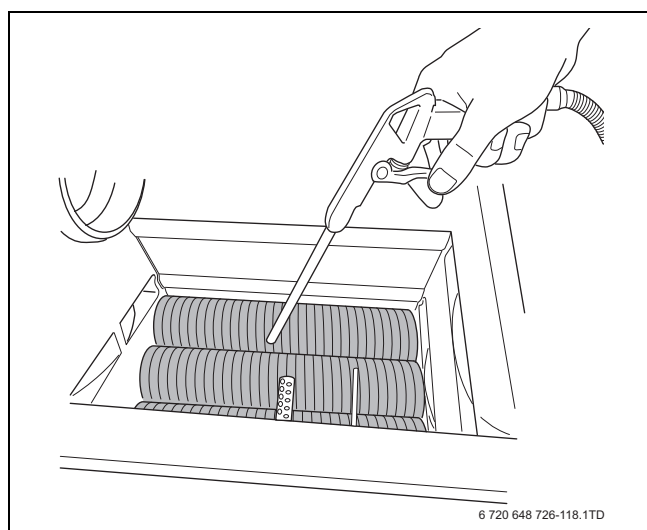

Fig. 117 Cleaning the heat exchanger

**CAUTION:** Damage to the installation due to undesired flue gas or condensate leakage.

- ▶ When installing the condensate collector, make sure that the 2 snap closures close smoothly. If this is not the case, the seal between the condensate collector and the flue pipe at the back of the heat exchanger may be leak.

- ▶ Refit the condensate collector.
- ▶ Connect the flexible condensate drain hose to the condensate collector.
- ▶ Re-install the condensate trap.
- ▶ Rinse the heat exchanger with clean water.
- ▶ Reassemble all boiler components in reverse order:
  - Burner with burner seal
  - Burner cover with fan and gas valve
  - Gas valve
  - Glow ignitor and ionisation electrode.
- ▶ Start up the boiler (→ chapter 10 “Commissioning”, page 37).

### 13.3 Checking and adjusting the gas/air-ratio

See section 10.2.7 “Checking and adjusting the gas/air-ratio”, page 41.

### 13.4 Function check in operating conditions

- ▶ Slowly open the gas valve by pushing on the gas valve and turning it ¼ rotation in an anticlockwise direction (→ fig. 79, page 39).
- ▶ Switch on the heating system by pressing the mains switch of the BC10 basic controller [1].
- ▶ Set the maximum CH flow temperature dial [8] and the DHW temperature dial [10] to the maximum temperatures.
- ▶ Enter a heat demand via the control unit and check that the boiler starts the heating mode.
- ▶ Open a hot water tap and check that the boiler starts the DHW mode.
- ▶ Set the maximum CH flow temperature dial [8] and the DHW temperature dial [10] to the required temperatures.

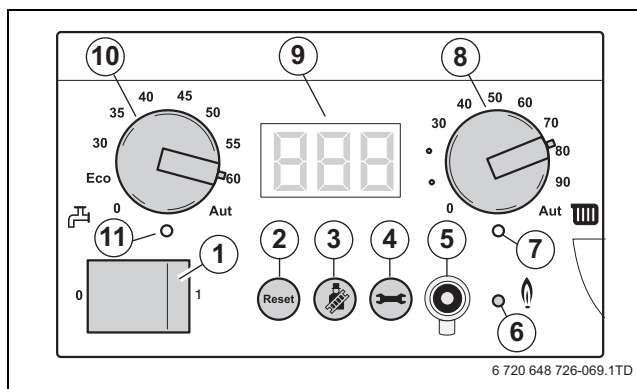

Fig. 118 BC10 basic controller

### 13.5 Service record log book

Complete the log book while carrying out needs-oriented maintenance.

- ▶ Enter your signature and the date after completing the maintenance activities.

Needs-oriented maintenance activities	Page	Date:	Date:	Date:	Date:	Date:
1. Cleaning the burner, heat exchanger and condensate trap after shutting down the heating system.	49	<input type="checkbox"/>	<input type="checkbox"/>	<input type="checkbox"/>	<input type="checkbox"/>	<input type="checkbox"/>
2. Checking and adjusting the gas/air ratio: • CO <sub>2</sub> content at full load • CO <sub>2</sub> content at part load.	41	_____ Pa _____ % _____ %	_____ Pa _____ % _____ %	_____ Pa _____ % _____ %	_____ Pa _____ % _____ %	_____ Pa _____ % _____ %
3. Function testing.	52	<input type="checkbox"/>	<input type="checkbox"/>	<input type="checkbox"/>	<input type="checkbox"/>	<input type="checkbox"/>
4. Confirming proper maintenance.						

Company stamp/ signature/date    Company stamp/ signature/date    Company stamp/ signature/date    Company stamp/ signature/date    Company stamp/ signature/date

Table 21

## 14 Display information

This section describes how to read operating and fault messages from the BC10 basic controller and what they mean.



For exact troubleshooting instructions please refer to the boiler service instructions. You may also contact Worcester technical support (0330 123 3366)

### 14.1 Removing the control panel from the boiler

To make it easier to use the buttons on the control panel when the boiler door is open and to make it easier to read out the values in the display, you can disassemble the control panel from the boiler door and hang it from the boiler frame.

- ▶ Open the boiler door (→ fig. 38 “Opening the boiler door”, page 26).
- ▶ Undo the 2 screws of the control panel at the back of the boiler door [1].

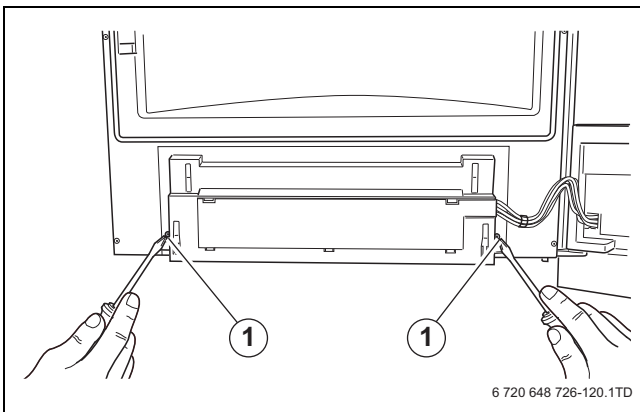

Fig. 119 Undoing the screws

- ▶ Undo the cable tie [1].
- ▶ Remove the control panel.

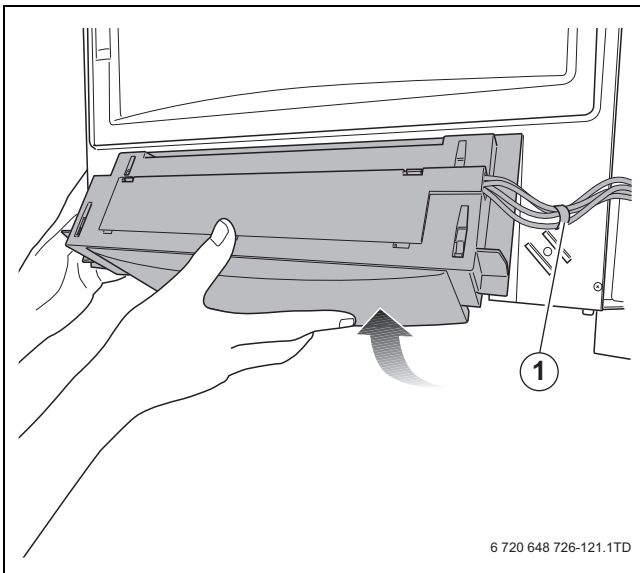

Fig. 120 Removing the control panel

[1] Cable tie

- ▶ Use the 2 hooks to hang the control panel from the boiler.

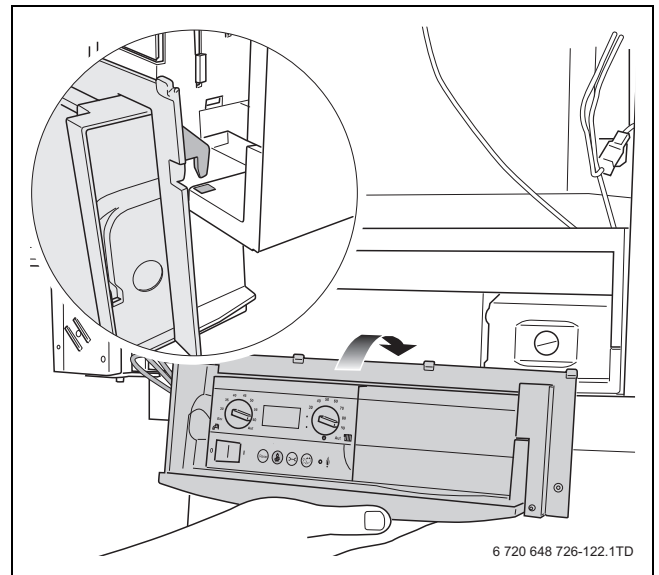

Fig. 121 Hanging the control panel from the boiler frame

### 14.2 Display readings

Display reading	Key to display reading	Unit	Range
24	Current CH flow temperature.	°C	0 - 130
P 1.6	Current system pressure.	bar	P 0.0 - P 4.0

Table 22 Display readings

### 14.3 BC10 Display settings

Display settings							
Display setting	Meaning of display setting	Unit	Range			Factory adjusted setting	
L 99	Configured target load (50 kW).	%	L 30 - L 99	/	L --	100 %	L --
L 99	Configured target load (65 kW).	%	L 20 - L 99	/	L --	100 %	L --
L 99	Configured target load (80 kW).	%	L 25 - L 99	/	L --	100 %	L --
L 99	Configured target load (100 kW).	%	L 20 - L 99	/	L --	100 %	L --
F 5	Configured target value of the pump run-over time. Note: Do not set a pump run-over time of less than <b>F 5</b> (= 5 minutes).	min.	F 00 - F 60	/	F 1d	24 h	F 5
C 1	DHW supply operating condition setting. Please note: If the setting <b>C 0</b> is displayed, the frost protection of the DHW supply has also been switched off.	Not applicable.			C 0	Off / On	C 1

Table 23 Display settings

### 14.4 BC10 Display codes

Display codes						
Main display code	Sub display code	Key to display code	Reset required?	LED on UBA 3	Other effects	
		Operating phase: Communication test while starting up. This display code flashes 5 times within 5 seconds while starting up to indicate that the communication between the UBA 3 and the BC10 basic controller is being tested. If a new UBA 3 or a new KIM was fitted, this code will flash for max. 10 seconds.		Off or flashing at 8 Hz		
		Fault: If this code continues to flash on the display, there is a fault in the communication between the UBA 3 and the BC10 basic controller.		Off or flashing at 8 Hz		
-A	208	Operating phase: The boiler is in flue gas test or service mode.		Off or flashing at 8 Hz	No heating operation and no DHW.	
-H	200	Operating phase: The boiler is in heating mode.		Off		
-H*	200	Operating phase: The boiler is in manual operation mode.		Off	The room temperature is too high.	
-H	201	Operating phase: The boiler is in DHW mode.		Off		
-H	201	Operating phase: Pump run-over time via the external hot water cylinder 130 seconds at the minimum speed. The "Burner" LED (On/Off) is off.		Off		
0A	202	Operating phase: The switch optimization program is activated. This program is activated if there has been any demand more frequently than once every 10 minutes. This means that the boiler cannot be restarted until at least 10 minutes have elapsed since initial burner start-up.		Off	The room temperature is not possibly reached.	
0A	305	Operating phase: The boiler cannot start up temporarily after a DHW request has ended.		Off		

Table 24 Display codes

Display codes						
Display code			Reset required?	LED on UBA 3	Other effects	
Main display code	Sub display code	Key to display code				
0C	283 <sup>2)</sup>		Pre-operative phase: The boiler prepares for a burner start-up whenever a heat demand or a DHW request arises.		Off	
0E	265 <sup>2)</sup>		Readiness for operation: The boiler is in standby mode. There is a current heat demand, but too much energy has been supplied.		Off	
0H	203 <sup>2)</sup>		Readiness for operation: The boiler is in standby mode. There is no current heat demand.		Off	
0L	284 <sup>2)</sup>		Ignition phase: The gas valve is activated.		Off	
0U	270 <sup>2)</sup>		Start-up phase: The boiler starts up after activation of the mains power supply or completion of a system reset. This code is displayed for a maximum of 4 minutes.		Off	
0Y	204 <sup>2)</sup>		Operating phase: The flow temperature sensor has detected that the current flow temperature is higher than the flow temperature setting on the BC10, or that it is higher than the flow temperature. Calculated according to heating requirements, or that it is higher than the flow temperature calculated for the DHW mode.		Off	The room temperature is not possibly reached.
0Y	276		Fault: The flow temperature sensor has measured a current flow temperature higher than 95 °C.	No 4) 5)	Off	The room temperature is not possibly reached.
0Y	277		Fault: The safety temperature sensor has measured a current safety temperature higher than 95 °C.	No 4) 5)	Off	The room temperature is not possibly reached.
0Y	285		Fault: The return temperature sensor has measured a current return temperature higher than 95 °C.	No 4) 5)	Off	The room temperature is not possibly reached.
1L	211		Fault: There is no connection between contacts 78 and 50 of the UBA 3 installation base.	No	Off	No heating operation and no DHW.
2E	207		Fault: The system pressure is too low (less than 0.2 bar).	No	Off	No heating operation and no DHW.
2F	260		Fault: The flow temperature sensor has not, after burner start-up, detected any temperature increase in the heating system water.	No	Off	
2F	271		Fault: The heating water temperature difference, measured between the flow temperature sensor and the safety temperature sensor, is too high.			
2P	212		Fault: The flow temperature sensor has measured a heating water temperature increase of over 5 °C/s.	No 4) 5)	Off	
2U	213		Fault: The temperature difference measured between the flow temperature sensor and the return temperature sensor, is more than 50 °C.	No 4) 5)	Off	
2Y	281		Fault: The pump has stopped or is running without water.	No	Off	

Table 24 Display codes

Display codes						
Display code			Reset required?	LED on UBA 3	Other effects	
Main display code	Sub display code	Key to display code				
24	282	Fault: No feedback from the pump.	No	Off		
3A	264	Fault: The tach signal from the fan has failed during the operating phase.	No 4) 5)	Off		
3C	217	Fault: No current of air after a certain time.	Yes 5) 6) 7) 8)	flashing 1 Hz	No heating operation and no DHW.	
3F	273	Operating phase: The appliance has been switched off for a couple of seconds, because it had been running without any interruption for 24 hours. This is a safety check.	No 4) 5)	Off		
3L	214	Fault: The tach signal from the fan is not present during the pre-operative or operating phase.	Yes 5) 6) 7) 8)	flashing 1 Hz	No heating operation and no DHW.	
3P	216	Fault: The fan is running too slowly.	Yes 5) 6) 7) 8)	flashing 1 Hz	No heating operation and no DHW.	
3Y	215	Fault: The fan is running too fast.	Yes 5) 6) 7) 8)	flashing 1 Hz	No heating operation and no DHW.	
4A	218	Fault: The flow temperature sensor has detected a flow temperature of over 105 °C.	Yes 5) 6) 7) 8)	flashing 1 Hz	No heating operation and no DHW.	
4C	224	Fault: There is no bridging cable between contacts 22 and 24 of the UBA 3 contact strip.	Yes 5) 6) 7) 8)	flashing 1 Hz	No heating operation and no DHW.	
4E	278	Fault: The sensor test has failed.	Yes 5) 6) 7) 8)	flashing 1 Hz	No heating operation and no DHW.	
4F	219	Fault: The safety temperature sensor has detected a flow temperature of over 105 °C.	Yes 5) 6) 7) 8)	flashing 1 Hz	No heating operation and no DHW.	
4L	220	Fault: The contacts for the safety temperature sensor have shorted or the safety temperature sensor has detected a flow temperature of over 130 °C.	Yes 5) 6) 7) 8)	flashing 1 Hz	No heating operation and no DHW.	
4P	221	Fault: The contacts for the safety temperature sensor have shorted.	Yes 5) 6) 7) 8)	flashing 1 Hz	No heating operation and no DHW.	
4U	222	Fault: The contacts for the safety temperature sensor have been interrupted.	Yes 5) 6) 7) 8)	flashing 1 Hz	No heating operation and no DHW.	
4Y	223	Fault: The contacts for the safety temperature sensor have been interrupted.	Yes 5) 6) 7) 8)	flashing 1 Hz	No heating operation and no DHW.	
5H	268	Operating phase: Component test phase.	No	Off		
6A	227	Fault: The system has detected an insufficient ionisation current during the ignition phase.	No 4) 5)	Off		

Table 24 Display codes

Display codes						
Display code			Key to display code	Reset required?	LED on UBA 3	Other effects
Main display code	Sub display code					
6A	227		Fault: The system has detected an insufficient ionisation current after four start-up attempts.	Yes 5) 6) 7) 8)	flashing 1 Hz	No heating operation and no DHW.
6C	228		Fault: The system has detected an ionisation current before burner start-up.	Yes 5) 6) 7) 8)	flashing 1 Hz	No heating operation and no DHW.
6C	306		Fault: An ionisation current has been measured after the burner shut down.	Yes 5) 6) 7) 8)	flashing 1 Hz	No heating operation and no DHW.
6L	229		Fault: The system has detected an insufficient ionisation current during the operating phase.	No 4) 5)	Off	
6P	269		Fault: The glow ignitor was activated for more than 10 minutes.	Yes 5) 6) 7) 8)	flashing 1 Hz	No heating operation and no DHW.
6Y	203		Fault: The ionisation current is too high.	Yes	flashing 1 Hz	No heating operation and no DHW.
7C	231		Fault: The power supply was interrupted during a locking fault 4A, 4C, 4E, 4F, 4L, 4P, 4U, 4Y.	Yes 5) 6) 7) 8)	flashing 1 Hz	No heating operation and no DHW.
7L	261		Fault: The UBA 3 is defect.	Yes 5) 6) 7) 8)	flashing 1 Hz	No heating operation and no DHW.
7L	280		Fault: The UBA 3 is defect.	Yes 5) 6) 7) 8)	flashing 1 Hz	
8Y	232 2)		Operating phase: The external switch contact is open.		Off	No heating operation and no DHW.
888			Start-up phase: The boiler starts up after activation of the mains power supply or completion of a system reset. This code is displayed for a maximum of 4 minutes.		On	
9A	235		Fault: The UBA 3 or the KIM is defective.	Yes	flashing 1 Hz	No heating operation and no DHW.
9H	237		Fault: The UBA 3 or the KIM is defective.	Yes	flashing 1 Hz	No heating operation and no DHW.
9H	267		Fault: The UBA 3 or the KIM is defective.	Yes	flashing 1 Hz	No heating operation and no DHW.
9H	272		Fault: The UBA 3 or the KIM is defective.	Yes 5) 6) 7) 8)	flashing 1 Hz	No heating operation and no DHW.
9L	234		Fault: The contacts for the gas valve have been broken.	Yes 5) 6) 7) 8)	flashing 1 Hz	No heating operation and no DHW.
9L	238		Fault: The UBA 3 or the KIM is defective.	Yes 5) 6) 7) 8)	flashing 1 Hz	
9P	239		Fault: The UBA 3 or the KIM is defective.	Yes 5) 6) 7) 8)	flashing 1 Hz	No heating operation and no DHW.

Table 24 Display codes

Display codes						
Display code			Key to display code	Reset required?	LED on UBA 3	Other effects
Main display code	Sub display code					
<b>99</b>	<b>233</b>		Fault: The UBA 3 or the KIM is defective.	Yes 5) 6) 7) 8)	flashing 1 Hz	No heating operation and no DHW.
<b>A01</b>	<b>B00</b>		Fault: The contacts to the outdoor-temperature sensor have shorted or are interrupted, the sensor has been connected incorrectly or is defective.	No	Off	Minimum outdoor temperature is assumed.
<b>A01</b>	<b>B08</b>		Fault: The contacts to the DHW temperature sensor have shorted or are interrupted, the sensor has been connected incorrectly or is defective.	No	Off	No DHW is heated any more.
<b>A01</b>	<b>B09</b>		Fault: The contacts to DHW temperature sensor 2 have shorted or are interrupted, the sensor has been connected incorrectly or is defective.	No	Off	No DHW is heated any more.
<b>A01</b>	<b>B10</b>		Fault: The boiler water does not warm up. Sensor lead broken or shorted, sensor connected incorrectly or defective, filling pump connected incorrectly or defective.	No	Off	No DHW available, but there is heating operation. The DHW priority is cancelled when the fault message appears.
<b>A01</b>	<b>B11</b>		Fault: Thermal disinfection has failed. Outlet flow during disinfection period too high, sensor lead broken or shorted, sensor connected incorrectly or defective, filling pump defective.	No	Off	Thermal disinfection was interrupted.
<b>A01</b>	<b>B16</b>		Fault: No connection to EMS. EMS bus system is overloaded, UBA3/MC10 is defective.	No	Off	The boiler no longer receives a heat demand. The heating system does not heat any longer.
<b>A01</b>	<b>B28</b>		Fault: Water pressure sensor generates a fault code. The digital water pressure sensor is defective.	No	Off	No heating operation and no DHW.
<b>A02</b>	<b>B16</b>		Fault: No communication with BC10. Contact problem at BC10 or BC10 is defective.	No	Off	BC10 settings are no longer taken over by RCxx devices.
<b>A11</b>	<b>B02</b>		Fault: Time not set. Failing time setting, e.g. due to a long power cut.	No	Off	Limited operation of all heating programs and fault list.
<b>A11</b>	<b>B03</b>		Fault: Date not set. Failing date setting, e.g. due to a long power cut.	No	Off	Limited operation of all heating programs, holiday function, fault list.
<b>A11</b>	<b>B21</b>		Fault: RC35-HK1 remote control. No remote control assigned, although room temperature control has been set.	No	Off	Since there is no actual room temperature information, room influence and optimization of the switch times do not work. The EMS works on the basis of the values last set on the remote control.
<b>A11</b>	<b>B22</b>		Fault: RC35-HK2 remote control. No remote control assigned, although room temperature control has been set.	No	Off	

Table 24 Display codes

Display codes						
	Main display code	Sub display code	Key to display code	Reset required?	LED on UBA 3	Other effects
	A 11	B 23	Fault: RC35-HK1 remote control. No remote control assigned, although frost protection type "FROST" has been set.	No	Off	Since there is no actual room temperature information, room influence and optimization of the switch times do not work. The EMS works on the basis of the values last set on the remote control.
	A 11	B 24	Fault: RC35-HK2 remote control. No remote control assigned, although frost protection type "FROST" has been set.			
	A 11	B 26	Fault: RC35-HK1 temperature sensor. The external temperature sensor of the remote control (control unit) of heating circuit 1 is defective.	No	Off	Since there is no actual room temperature information, room influence and optimization of the switch times do not work. The EMS works on the basis of the values last set on the remote control.
	A 11	B 27	Fault: RC35-HK2 temperature sensor. The external temperature sensor of the remote control (control unit) of the heating circuit is defective.			
	A 12	B 15	Fault: The contacts to the switch sensor have shorted or are interrupted, the sensor has been connected incorrectly or is defective.	No	Off	Limited operation of all heating programs, holiday function, fault list.
	A 12	B 16	Fault: WM10 not available or no communication. WM10 or bus circuit connected incorrectly or defective, WM10 is not recognized by the RC35.	No	Off	Heating circuit pump 1 is activated continuously.
	A 18	B 25	Fault: Conflicting addresses. Both RC25 and RC35 are registered as Master.	No	Off	Both RC35 and RC25 activate heating circuit 1 and DHW. Depending on the heating programs set and the required room temperatures, the heating system can no longer work correctly. DHW mode does not work well.
	A 21	B 06	Fault: RC25-HK1 temperature sensor. The integrated temperature sensor of the remote control (control unit) of heating circuit 1 is defective.	No	Off	Since there is no actual room temperature information, room influence and optimization of the switch times do not work. The EMS works on the basis of the values last set on the remote control.
	A 21	B 16	Fault: RC25-HK1 communication. RC25 addressed incorrectly, wired incorrectly or defective.	No	Off	Since there is no actual room temperature information, room influence and optimization of the switch times do not work.
	A 22	B 06	Fault: RC25-HK2 temperature sensor. The integrated temperature sensor of the remote control (control unit) of heating circuit 2 is defective.	No	Off	Since there is no actual room temperature information, room influence and optimization of the switch times do not work. The EMS works on the basis of the values last set on the remote control.
	A 22	B 16	Fault: RC25-HK2 communication. RC25 addressed incorrectly, wired incorrectly or defective.	No	Off	Since there is no actual room temperature information, room influence and optimization of the switch times do not work.

Table 24 Display codes

Display codes						
Display code			Key to display code	Reset required?	LED on UBA 3	Other effects
Main display code	Sub display code					
A32	B07		Fault: The contacts to the heating circuit flow sensor have shorted or are interrupted, the sensor has been connected incorrectly or is defective.	No	Off	Heating circuit pump 2 is activated depending on the preset value. The power to the mixer is switched off and the mixer stays in the state it was last put in (can be adjusted manually).
A32	B16		Fault: MM10 not available or no communication. The heating circuit addresses on the MM10 and the RC35 do not match up, the MM10 or the bus circuit is connected incorrectly or is defective, MM10 is not recognized by the RC35.	No	Off	Heating circuit 2 cannot be operated correctly. MM10 and the mixer automatically goes into emergency operation. Heating circuit pump 2 is activated continuously. Monitor data in the RC35 is invalid.
CA	286		Fault: The return temperature sensor has measured a return temperature higher than 105 °C.	Yes 5) 6) 7) 8)	flashing 1 Hz	No heating operation and no DHW.
CU	240		Fault: The contacts for the return temperature sensor have shorted.	Yes 5) 6) 7) 8)	flashing 1 Hz	No heating operation and no DHW.
EL	290		Fault: The UBA 3 or the KIM is defective.	No 4) 5)	Off	No heating operation and no DHW.
E <sub>9)</sub>	242 - 287		Fault: The UBA 3 or the KIM is defective.	Yes 5) 6) 7) 8)	flashing 1 Hz	No heating operation and no DHW.
H 7			Operating phase: The system pressure is too low (less than 1.0 bar).	No	Off	Possibly no heating operation or no DHW available.
H 7			Operating phase: The system pressure is too low (less than 1.0 bar).	No	Off	Possibly no heating operation or no DHW available.
P - -			Operating phase: The system pressure is too high (over 4.0 bar) or the pressure sensor has not detected a system pressure (boiler functioning normally).	No	Off	
rE			Fault: Reset is carried out. After pressing the "Reset" button this code is displayed for 5 seconds.		Off	

Table 24 Display codes

- 1) Any indication with a permanent dot in the bottom right-hand corner.
- 2) Only visible on the Service Tool or a specific RC regulator.
- 3) Any indication with a flashing dot in the bottom right-hand corner.
- 4) This fault code may deactivate again automatically after a specific time (without reset). Heating and DHW are now available once more.
- 5) If more faults occur simultaneously, the relevant fault codes are shown after another. If one of these fault codes is a flashing fault code, the other fault codes will also flash.
- 6) The cause of this fault must be corrected first.
- 7) The display values, e.g. the system pressure, are also shown as flashing codes.
- 8) In the event of this fault, the circulation pump is started up and remains in continuous operation in order to minimise the possibility of the heating system freezing up.
- 9) "E" + random digit or letter.

### 14.5 Re-fit the control panel in the boiler

- ▶ Take the control panel from the boiler frame.
- ▶ Attach the control panel to the boiler door again by following the above procedure in reverse order and secure it with 2 screws.

## 15 Technical specifications

The technical specifications serve to provide information about the boiler performance profile.

	Unit	GB162-50	GB162-65	GB162-80	GB162-100
<b>Rated thermal load for G20</b>	kW	14.6 - 47.5	14.6 - 62.0	19.3 - 82.0	19.3 - 96.5
<b>Rated heating capacity, heating curve 80/60 °C</b>	kW	14.2 - 46.6	14.2 - 60.5	18.9 - 80.0	19.0 - 94.5
<b>Rated heating capacity, heating curve 50/30 °C</b>	kW	15.6 - 49.9	15.6 - 65.0	20.8 - 84.5	20.5 - 99.5
<b>Boiler efficiency at max. capacity, heating curve 80/60 °C</b>	%	98	97	97	98
<b>Boiler efficiency at max. capacity, heating curve 50/30 °C</b>	%	105		107	
<b>Rated efficiency, heating curve 75/60 °C</b>	%	106	106	107	107
<b>Rated efficiency, heating curve 50/30 °C</b>	%	110	108	110	110
<b>Standby heat loss</b>	%	0.05	0.05	0.05	0.06
<b>Hot water circuit</b>					
<b>Minimum water circulation volume</b>	l/h			0	
<b>Maximum volume flow</b>	l/h			5,000	
<b>CH (boiler) flow temperature</b>	°C	30 - 90, can be set on the BC10 basic controller			
<b>Resistance at <math>\Delta T_{20}</math></b>	mbar	90	170	225	320
<b>Max. boiler working pressure</b>	bar			4	
<b>Content of heating circuit heat exchanger</b>	l			5	
<b>Pipe connections</b>					
<b>Gas connection</b>	inch			G1"	
<b>Heating water connection</b>	inch	G1½" union nut with female thread enclosed			
<b>Condensate water connection</b>	mm	Ø 24			
<b>Flue gas values</b>					
<b>Condensate water quantity for natural gas G20, 40/30 °C</b>	l/h	5.2	6.9	9.0	10.8
<b>pH value of condensate water</b>	pH	approximately 4.1			
<b>Flue gas mass flow rate, full load</b>	g/s	21.6	27.2	35.3	44.9
<b>Flue gas temperature 80/60 °C, full load</b>	°C	60	64	67	76
<b>Flue gas temperature 80/60 °C, part load</b>	°C	57	57	61	57
<b>Flue gas temperature 50/30 °C, full load</b>	°C	43	43	48	51
<b>Flue gas temperature 50/30 °C, part load</b>	°C	33	33	34	34
<b>CO<sub>2</sub> content at full load, natural gas G20</b>	%	9.3/9.2	9.4/9.2	9.3	9.4
<b>Free fan feed pressure</b>	Pa	85	120	139	220
<b>Flue gas connection</b>					
<b>Flue gas value group for air intake/flue gas system</b>		II <sub>6</sub> (G61)			
<b>Ø flue gas system, room-air dependent</b>	mm	Ø100 or Ø110 (Ø100 with air intake strainer basket, accessory)			
<b>Ø flue gas system, room-air independent</b>	mm	standard Ø80/125 concentric		standard Ø100/150 concentric	
<b>Electrical data</b>					
<b>Mains connection voltage</b>	V	230, 50 Hz			
<b>Electrical protection rating</b>		IP X4D (B <sub>23</sub> ; IP X0D)			
<b>Electrical power consumption, full load (without a pump group)</b>	W	45	99	97	147
<b>Electrical power consumption, partial load (without a pump group)</b>	W	20	21	30	28
<b>Boiler dimensions and weight</b>					
<b>Height × width × depth (with pump group)</b>	mm	1413.5 × 520 × 465			
<b>Weight (without a pump group)</b>	kg	70			
<b>Other specifications</b>					
<b>Gas injector diameter G20</b>	mm	-	-	8.4	8.4
<b>Gas injector diameter G31</b>	mm	5.3	5.3	4.7	4.7

Table 25 Technical specifications

**Pump group**

Pump group	Unit	GB162-50/65/80/100
<b>General</b>		
Pump group components		Casing, gas isolating valve, pressure relief valve, stop valves, check valves, drain cock, pressure gauge, pump.
<b>Pump type</b>		
UPER 25-80 pump group		UPER 25-80
UPS 25-80 pump group		UPS 25-80

Table 26 Pump group

**Operating conditions for time constants**

Operating conditions and time constants	Unit	GB162-50/65/80/100
Maximum ambient temperature	°C	40
Maximum flow temperature	°C	90
Maximum working pressure (boiler)	bar	4
Current rating		230 V AC, 50 Hz,  10 A, IP X4D

Table 27 Operating conditions and time constants

**Fuels and configurations**

Fuels and configurations	GB162-50/65/80/100
GB162-65/80/100	Natural gas <b>H</b> (G20) and LPG <b>3P</b> (G31)
Version	B <sub>23</sub> , C <sub>13</sub> , C <sub>33</sub> , C <sub>43</sub> , C <sub>53</sub> , C <sub>63</sub> , C <sub>83</sub> depending on room air and independent of room air (Compliance with increased tightness requirements with operation independent of room air).
Gas category according to EN 437	GB/IE II <sub>2H3P</sub> 20; 37 mbar

Table 28 Fuels and configurations

**Hydraulic resistance of the boiler**

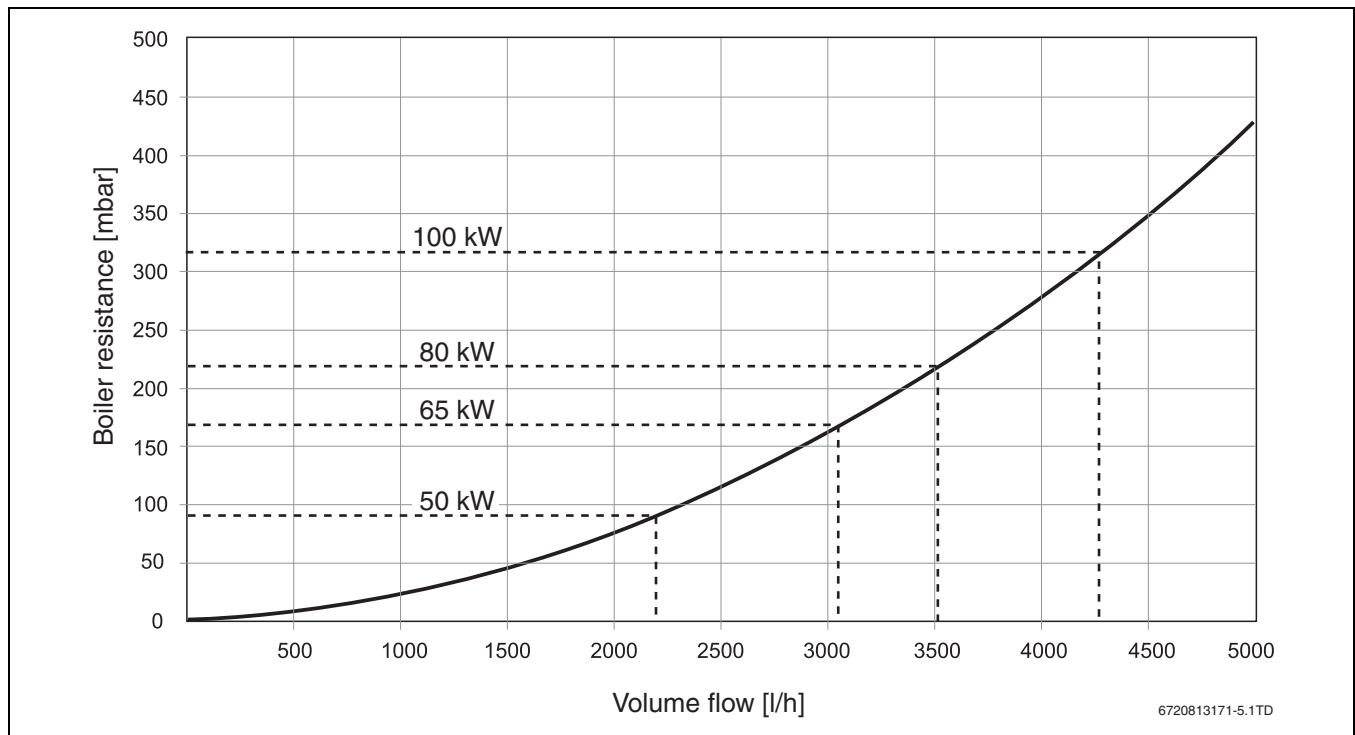

Fig. 122 Boiler resistance curve

### 15.1 Spare parts list GB162-80/100

The following are parts commonly required due to damage or replacements. Their failure will affect safety or performance of this appliance. For a pictorial representation of the part see the respective position number on the exploded view pictures on page 64 and 65.

	Description	Product No.
1	Door	8718689173
2	Sealing door	7101382
3	Door lock	7101384
4	Hinge door	7101520
5	Wall mounting bracket	7101386
6	Bracket left	7101388
7	Bracket right	7101390
8	Adjusting foot	7101394
9	Transport slide (L + R)	7101392
10	Drawer modules	7101496
11	Screw 4.2 x 8.5 x (10 pc)	7100748
12	Condensate collector	7101396
13	Seal condensate collector	7746900152
14	Seal 80 mm	7101400
15	Upper side condensate collectors	7101402
16	Mounting flue-gas pipe	7101398
17	Exhaust pipe	7101404
18	Adapter air inlet	7101412
19	Seal 100 mm	73939
20	Condensate trap	8718600611
21	Seal condensate trap	73463
22	Drain pipe	7101410
23	Seal bush (white)	73449
24	Condensate drain pipe	7101535
25	Fan – 100 kW	7101454
26	Seal Fan	7101450
27	O-ring 70 x 3 (2 pc)	7101416
28	Venturi	8718600301
29	Seal Ø 60 mm	7099686
30	Gas valve	8718601978
31	Seal 33 x 24 x 3.5 (10 pc)	73368s
32	Gas pipe – 100 kW	7101466
33	Flange gas valve	8718600286
34	O-ring (10 pc)	7101504
35	Orifice 100 kW	7746901753
36	Screw M5 x 20 (10 pc)	7099650
37	Screw M5 x 16 (10 pc)	7101484
38	Screw M6 x 16 (10 pc)	7101486
39	Air inlet pipe – 100 kW	7101462
40	Seal (10 pc)	7101482
41	Air vent revision set	7101428
42	Clip	7101430
43	Sensor NTC	7101532
44	Clip (3 x 2 pc)	774670063
45	O-ring 9.19 x 2.62 (10 pc)	78175s
46	Pressure sensor	8718600019
47	O-ring 14 x 1.78 (10 pc)	7099069
48	Return/Supply pipe	7101438
49	Connection nipple CH	73080
50	Clip	7746700069

	Description	Product No.
51	O-ring (10 pc)	7101488
52	Ignitor housing (incl. glow ignitor and ionisation electrode)	8718600172
60	Heat exchanger	8718600269
61	Cover controller BC10	73698
62	Burner	7101444
63	Seal Burner	7101446
65	Burner box with clamps	7101448
66	Facia	8718689154
67	Controller connection plate	73692
68	On/Off switch	7099041
69	Knob BC10	38724
70	Draw connection board	73909
71	Cover control box	7101498
72	Cover connection board 230 V	73815
73	Transformer	7101640
74	UBA 3	8718600083
75	Fuse 5AF (10 pc)	8718601966
76	Connection board	7099042
77	Electronic connection red	73776
78	Electronic connection grey	73774
79	Electronic connection green	73773
80	Electronic connection blue	73775
81	Electronic connection orange	73777
82	Flue gas exhaust connection	7746901750
83	Flue gas adapter	73936
84	Measure nipple cap	7101424
85	Seal 150 mm	73968
86	Cable harness low voltage – 100 kW	7101472
87	Cable harness high voltage	7101478
88	Cable harness on/off switch	7101476
89	Cable harness earth	7101474
90	Mains cable	7101471
91	Union nut 1½" (5 pc)	73481s
92	Seal (10 pc)	7098266
93	Nut 1"	7099416
95	Gas valve	7101512
96	Pump UPS 25-80-130	73954
97	Drain cock	7098666
100	Casing	7101514
101	Thermometer	73890
102	Manometer	7101506
103	Safety valve 4 bar	73957
104	Clip (5 pc)	73651s
105	Seal (5 pc)	73638s
106	Drain cock	7101516
107	Connection pressure gauge	73081
108	Drain pipe	7101531
109	Plug protector	73948
120	230 Volt converter with box	78079
121	230 Volt converter	78091
131	Valve housing supply (single)	74547
132	Valve housing return (single)	74549
-	Screw 6.3 x 19 (10 pc)	73986

Exploded view GB162-80/100

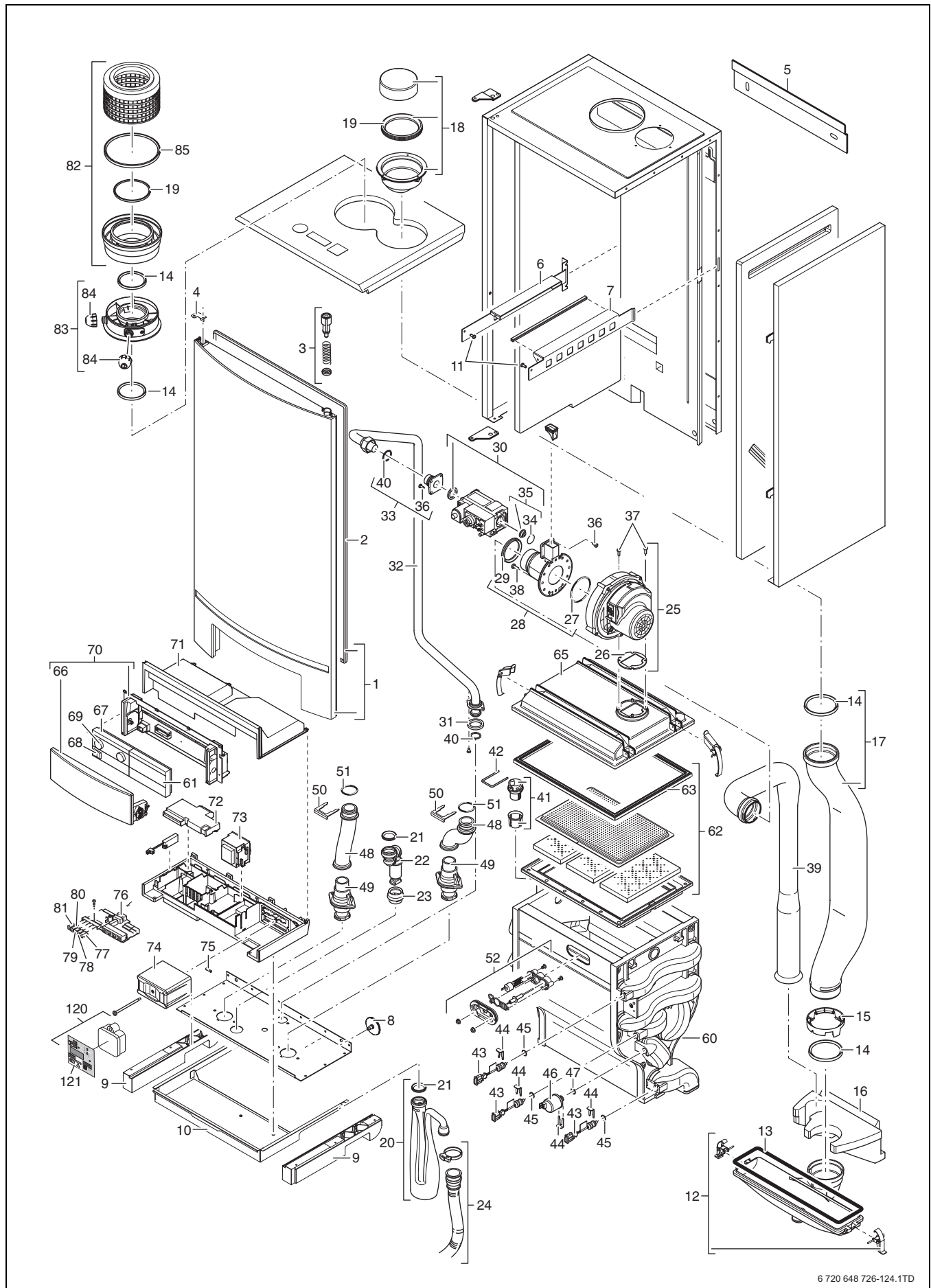

6 720 648 726-124.1TD



### 15.2 Spare parts list GB162-50/65

For a pictorial representation of the part see the respective position number on the exploded view pictures on page 68 and 69.

	Description	Product No.
1	Door	8718689173
2	Sealing door	7101382
3	Door lock	7101384
4	Hinge door	7101520
5	Wall mounting bracket	7101386
6	Bracket left	7101388
7	Bracket right	7101390
8	Adjusting foot	7101394
9	Transport slide (L + R)	7101392
10	Drawer modules	7101496
11	Screw 4.2 x 8.5 x (10 pc)	7100748
12	Condensate collector	7101396
13	Seal condensate collector	7746900152
14	Seal 80 mm	7101400
15	Upper side condensate collectors	7101402
16	Mounting flue-gas pipe	7101398
17	Exhaust pipe	73927
18	Adapter air inlet	7101412
19	Seal 80 mm	7101400
20	Condensate trap	8718600611
21	Seal condensate trap	73463
22	Drain pipe	7101410
23	Seal bush (white)	73449
24	Condensate drain pipe	7101535
25	Fan	73924
26	Seal Fan	7101450
27	Seal Fan	7099712
28	Venturi	8718600300
29	Seal Ø 50 mm	7099728
30	Gas valve	8718600298
31	Seal 33 x 24 x 3.5 (10 pc)	73368s
32	Gas pipe	7101466
33	Flange gas valve	8718600286
34	O-ring (10 pc)	7101504
36	Screw M5 x 20 (10 pc)	7099650
37	Screw M5 x 16 (10 pc)	7101484
38	Screw M6 x 16 (10 pc)	7101486
39	Air inlet pipe	7101462
40	Seal (10 pc)	7101482
41	Air vent revision set	7101428
42	Clip	7101430
43	Sensor NTC	7101532
44	Clip (3 x 2 pc)	774670063
45	O-ring 9.19 x 2.62 (10 pc)	78175s
46	Pressure sensor	8718600019
47	O-ring 14 x 1.78 (10 pc)	7099069
48	Return/Supply pipe	7101438
49	Connection nipple CH	73080
50	Clip	7746700069
51	O-ring (10 pc)	7101488

	Description	Product No.
52	Ignitor housing (incl. glow ignitor and ionisation electrode)	8718600172
60	Heat exchanger	8718600269
61	Cover controller BC10	73698
62	Burner	7101444
63	Seal Burner	7101446
65	Burner box with clamps	7101448
66	Facia	8718689154
67	Controller connection plate	73692
68	On/Off switch	7099041
69	Knob BC10	38724
70	Draw connection board	73909
71	Cover control box	7101498
72	Cover connection board 230 V	73815
73	Transformer	7101640
74	UBA 3	8718600083
75	Fuse 5AF (10 pc)	8718601966
76	Connection board	7099042
77	Electronic connection red	73776
78	Electronic connection grey	73774
79	Electronic connection green	73773
80	Electronic connection blue	73775
81	Electronic connection orange	73777
82	Flue gas exhaust connection	7746900414
83	Flue gas adapter	73936
84	Measure nipple cap	7101424
85	Seal 125 mm	7746900323
86	Cable harness low voltage	73944
87	Cable harness high voltage	7101478
88	Cable harness on/off switch	7101476
89	Cable harness earth	7101474
90	Mains cable	7101471
91	Union nut 1½" (5 pc)	73481s
92	Seal (10 pc)	7098266
93	Nut 1"	7099416
95	Gas valve	7101512
96	Pump UPER 25-80-130	7101508
97	Drain cock	7098666
100	Casing	7101514
101	Thermometer	73890
102	Manometer	7101506
103	Safety valve	7099949
104	Clip (5 pc)	73651s
105	Seal (5 pc)	73638s
106	Drain cock	7101516
107	Connection pressure gauge	73081
108	Drain pipe	7101531
109	Plug protector	73948
120	230 Volt converter with box	78079
121	230 Volt converter	78091
122	Pipe three way valve/boiler	73076
123	Pipe three way valve/connection set	73077
124	Return pipe hot water tank	73078
125	Pipe straight DN 25mm L=30cm	73079

	Description	Product No.
<b>126</b>	Body three way valve	20374
<b>127</b>	Motor three way valve	20375
<b>128</b>	Three way valve complete	20373
<b>129</b>	Check valve	7746900606
<b>130</b>	Repair set three way valve 1"+ 5/4"	75400
<b>131</b>	Valve housing supply (single)	74547
	Valve housing supply (combi)	74548
<b>132</b>	Valve housing return (single)	74549
	Valve housing return (combi)	74550
-	Screw 6.3 x 19 (10 pc)	73986
-	Clip suction pipe	73053
<b>Spare part boiler</b>		
-	Hot water sensor	7098774
-	Adapter cable boiler sensor	73754
-	Adapter cable three way valve	7099585
-	Wire hot water tank	74552
-	Sensor locking pin	73495
-	Conversion set	7746901190
-	Flue gas adapter DN 160-80 with the following spare parts	7101422
-	Cap flue gas adapter DN 160-80	7101418
-	Seal DN 110	7101492
-	Seal DN 160	7101494

Exploded view GB162-50/65

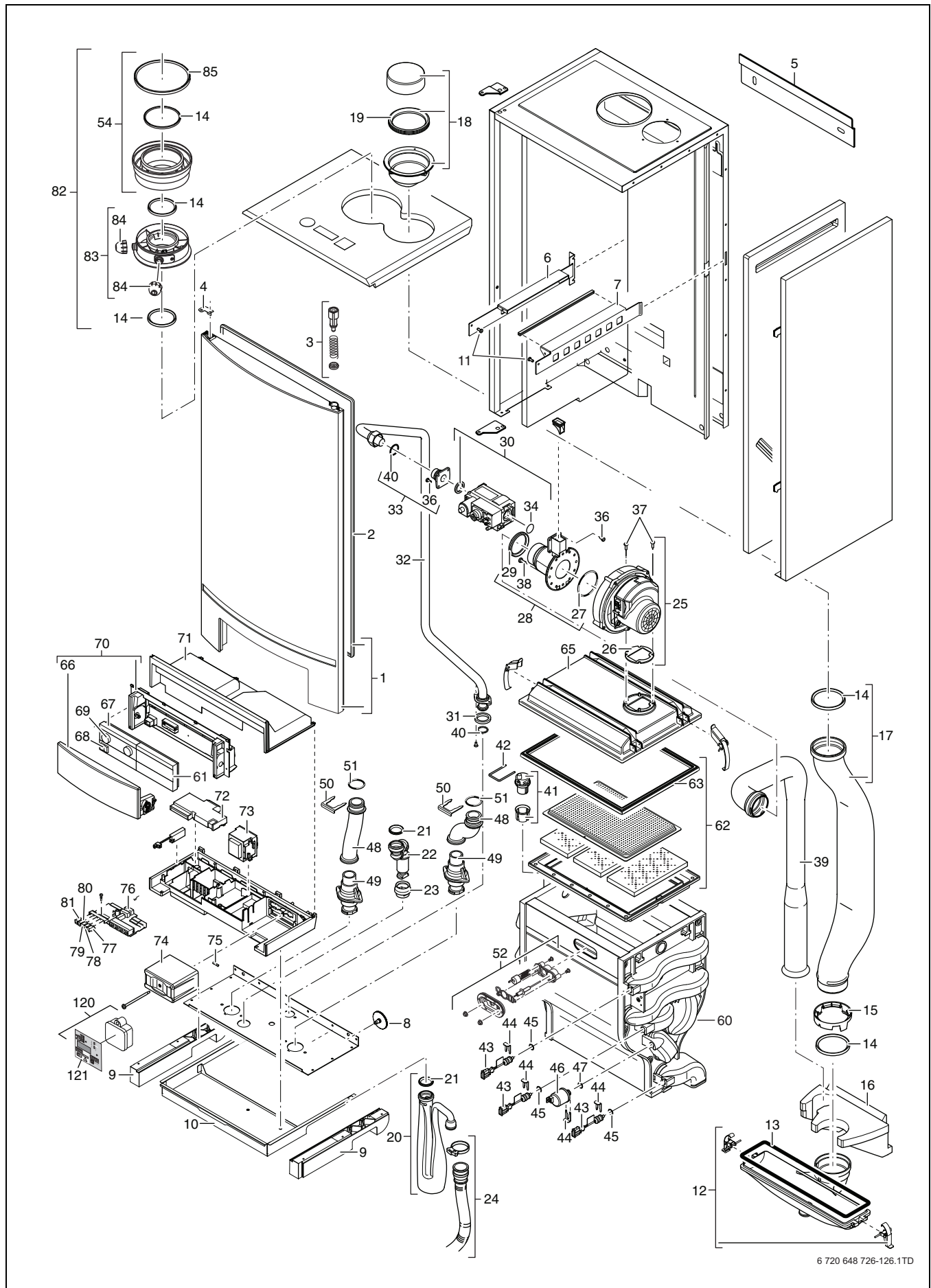

6 720 648 726-126.1TD

Exploded view pump group with DHW GB162-50/65

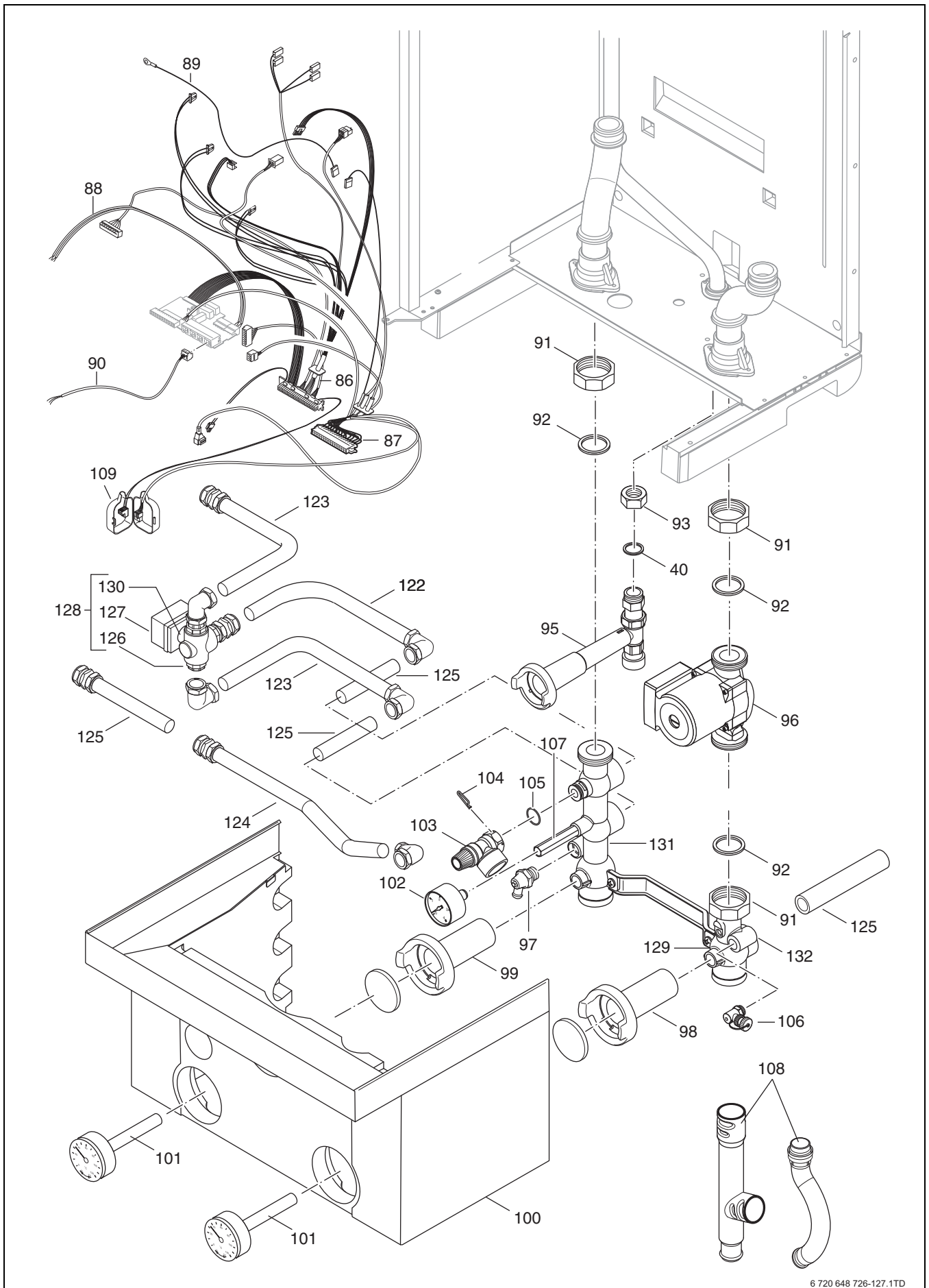

6 720 648 726-127.1TD

---

## Notes

## Notes

Worcester, Bosch Group  
Cotswold Way, Warndon, Worcester WR4 9SW.  
Tel. 0330 123 9559

Worcester, Bosch Group is a brand name of Bosch Thermotechnology Ltd.  
[worcester-bosch.co.uk](http://worcester-bosch.co.uk)

6720813171

**WORCESTER, BOSCH GROUP:**

TECHNICAL SUPPORT:	0330 123 3366
APPOINTMENTS:	0330 123 9339
SPARES:	0330 123 9779
LITERATURE:	0330 123 9119
TRAINING:	0330 123 0166
SALES:	0330 123 9669



**WORCESTER**  
**Bosch Group**