

# 28i RSF

WALL MOUNTED COMBINATION BOILER FOR CENTRAL HEATING  
AND MAINS FED DOMESTIC HOT WATER

## INSTALLATION AND SERVICING INSTRUCTIONS



This appliance is for use  
with Natural Gas

Cat I<sub>2H</sub>

GC NUMBER

N.G. 47 311 54



### BOILER OUTPUT

To Domestic Hot Water –  
Modulated Control  
Minimum 8.5 kW  
Maximum 27.5 kW

To Central Heating –  
Modulated Control  
Minimum 10.5 kW  
Maximum 27.5 kW

THESE INSTRUCTIONS APPLY IN THE UK ONLY AND MUST BE LEFT WITH THE  
USER OR AT THE GAS METER.

READ THE INSTRUCTIONS BEFORE STARTING WORK - THEY HAVE BEEN  
WRITTEN TO MAKE THE INSTALLATION EASIER AND PREVENT HOLD-UPS.

This appliance must be installed by a competent person in accordance  
with the Gas Safety (Installation and Use) Regulations 1998

# Contents

1. Installation Regulations	Page 2
2. Introduction	Page 2
3. Technical Data	Page 4
4. Siting the Appliance	Page 6
5. Siting the Flue	Page 7
6. Air Supply	Page 7
7. Sealed System	Page 8
8. Open Vent System	Page 8
9. Domestic Hot Water	Page 9
10. Gas Supply	Page 9

11. Electrical	Page 10
12. Installing the Appliance	Page 13
13. Commissioning the Appliance	Page 18
14. Handover	Page 20
15. Inspection and Service	Page 21
16. Replacement of Parts	Page 22
17. Operational Flow Diagrams	Page 27
18. Fault Finding	Page 29
19. Component Parts List	Page 37

## 1. Installation Regulations

1.1 Gas Safety (Installation and Use) Regulations, October 1998  
All gas appliances must be installed by a competent person in accordance with the above regulations. Failure to install appliances correctly could lead to prosecution.

1.2 The manufacturers notes must not be taken, in any way, as overriding statutory obligations.

1.3 The compliance with a British Standard does not, of itself, confer immunity from legal obligations. In particular the installation of this appliance must be in accordance with the relevant requirements of the following;

Gas Safety (Installation and Use) Regulations 1998 as amended.

Current IEE Wiring Regulations BS 7671.

Local Building Regulations.

Building Standards (Scotland)(Consolidation).

Bylaws of the local Water Company.

Health and Safety Document No. 635 (Electricity at Work Regulations).

The British Gas Material and Installation Specification for central heating and hot water

It should be in accordance with the relevant recommendations of the following British Standards.

BS6798:1987 Specification for installation of gas fired hot water boilers of rated input not exceeding 60 kW.

BS5449:1990 Central Heating for Domestic Premises.

BS5546:1990 Installation of gas hot water supplies for domestic purposes.

BS5440:1:2000 Flues and Ventilation for gas appliances of rated input not exceeding 60 kW: Flues.

BS5440:2:2000 Flues and Ventilation for gas appliances of rated input not exceeding 70kW: Air Supply.

BS6891:1988 Installation of low pressure gas pipework installations up to 28mm (R1).

BS7593:1993 Central Heating system cleansing and flushing.

1.4 To ensure that the installation will perform to the highest standards, the system and components should conform to any other relevant British Standards in addition to those mentioned in the instructions.

1.5 The appliance complies with the Essential Requirements of the Gas Appliance Directive and other Directives currently applicable.

1.6 This appliance contains no asbestos products.

There is no potential hazard due to the appliance being electrically unsafe.

There are no substances used that are a potential hazard in relation to the COSHH Regulations 1988.

1.7 The advice and instructions given in this document covers, as far as possible, the foreseeable situations which may arise. Contact Worcester Heat Systems Technical Helpline for advice on specific installations.

1.8 Product Liability regulations indicate that, in certain circumstances, the installer can be held responsible, not only for mistakes on his part but also for damage resulting from the use of faulty materials. We advise that, to avoid any risk, only quality approved branded fittings be used.

## 2. Introduction

**(benchmark)** The **Benchmark** initiative is the new code of practice to encourage the correct installation, commissioning and servicing of domestic central heating boilers and system equipment.

**The 'Log-book' is a vital document that must be completed by the installer at the time of installation. It confirms that the boiler has been installed and commissioned according to the manufacturers instructions.**

Without the completion of the Log-book, manufacturers may refuse to respond to a call-out from a householder, who will be advised that he or she must call back the installer, who has not fulfilled his obligations to record the information required by the initiative.

**It is important that:**

The services and the system are properly flushed as specified.

The User is clearly instructed on the correct operation of the appliance.

The benefits of regular servicing are explained - to maintain the efficiency and extend the life of the appliance.

### 2.1 General Information

The appliance is set to give the maximum output of 27.5 kW to the domestic hot water and to the heating system. The hot water flow rate is limited to a nominal 10 l/min at a maximum temperature rise of 40°C.

The sanitary water section of the appliance is suitable for mains water pressure of up to 10bar.

### 2.2 Electrical Supply

230V · 50Hz. Load 180 watts. External fuse 3A, Internal fuses F1 - 2A, F2 - 1.0A (20mm).

### 2.3 Gas supply

The appliance requires a maximum of 3.17 m<sup>3</sup>/h of natural gas (G20). The installation and the connection of the gas supply to the appliance must be in accordance with BS6891.

The meter or regulator should deliver a dynamic pressure of 20 mbar (G20) at the appliance, which is equivalent to about 19-19.5 mbar at the gas valve inlet pressure test point.

### 2.4 Installation

The appliance is suitable for indoor installation only and for use with a sealed system only.

Do not place anything on top of the appliance.

It is a room sealed appliance and a separate combustion air supply is not required in any room or compartment in which the appliance is fitted.

If the appliance is fitted in a cupboard or a compartment is built around it after installation, then the structure must conform to the requirements of BS6798 and BS5440 Part 2. However, because of the low casing losses, there is not a need for the cooling ventilation openings in the compartment. **The spaces specified in Section 6.3 must be maintained.**

There is space for the service pipes to pass at the back of the appliance.

### 2.5 Flue

The appliance has a multi-directional fanned flue system.

The standard telescopic flue assembly length is from 330mm to 725mm.

Extension flue kits are available for flue lengths up to 2500mm.

An optional vertical flue kit to provide for flue lengths up to 3400mm including vertical flue terminal.

A terminal guard, Type K2, GC 393 553, is available from Tower Flue Components, Vale Rise, Tonbridge, TN9 1TB.

Do not allow the flue terminal fitted to the outside wall to become obstructed or damaged.

A kit for internal fixing of the flue is available separately.

## 2.6 Controls

Central Heating Temperature control knob.

A fascia mounted programmer is provided.

A room thermostat and/or an externally mounted programmer for mains voltage operation may be connected to the appliance.

Fig. 1. Facia controls

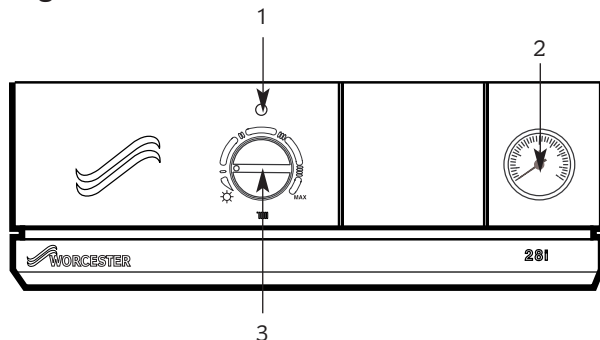

- 1 Mains Indicator Light
- 2 System Pressure Gauge
- 3 Central Heating Temperature Control

## 2.7 System

**benchmark** All dirt must be flushed from the system before operating the appliance.

The connections in the system must withstand a pressure of upto 3 bar.

Radiator valves must conform to BS2767: 10:1977.

Table 3 gives the pump head available for the system and the required temperature differential.

A drain cock must be fitted to the lowest point and an air vent to the highest point of the system.

## 2.8 Showers, Bidets, Taps and Mixing Valves

All taps and mixing valves must be suitable for the available mains pressure and temperatures up to 55°C. It may be necessary to fit a pressure reducing valve.

Hot and cold mains fed water can be supplied to over-rim bidets but is subject to local water company requirements.

The flow of water from individual outlets varies on all mains fed systems that are not fitted with flow balancing valves. If a pressure equalising valve is fitted then the domestic hot water temperature should be set to maximum.

Thermostatically controlled shower valves give extra comfort and protection.

## 2.9 Safety

The appliance must not be operated with the inner casing cover removed. The gas and electricity supplies must be turned off before working on the appliance.

Temperature monitoring controls are fitted to prevent overheating. Automatic frost protection is provided together with automatic pump seizure protection.

The gas valve solenoids are automatically checked for gas soundness.

**IMPORTANT: Where back-flow prevention devices, including water meters, are fitted the expansion of hot water into cold water main can be prevented. This can result in a pressure build-up that may cause damage to the boiler and household devices such as showers, washing machines etc.**

**In these cases we recommend that a mini-expansion vessel be fitted adjacent to the boiler in the cold water pipe.**

## 2.10 Operation

**Domestic Hot Water:** With a demand for hot water the burner will light at its maximum setting and then automatically adjust its output to maintain the temperature of the delivered water.

When hot water is no longer required, the burner will extinguish. The fan and pump will continue to run for a short period to dissipate the residual heat from the appliance.

**Central Heating:** With a demand for heating the burner will light at its minimum setting and gradually increase to give a controlled temperature rise. When the required heating temperature is achieved the output of the appliance is then automatically adjusted to maintain the temperature of the system. The output can reduce down to a minimum of 10.5 kW. If the system no longer requires even the minimum output to maintain the desired room temperature the burner will extinguish. The fan and pump will continue to run to dissipate the residual heat from the appliance. The appliance will remain off for a fixed period before re-lighting to automatically meet the system requirements.

**Domestic Hot Water and Central Heating:** The appliance will supply heat to the central heating system as required. A demand for domestic hot water at a tap or shower will override the central heating requirement for the period of the domestic hot water demand. When hot water is no longer required the appliance will return to the central heating state and its normal mode of operation. The fan will continue to run to dissipate the residual heat from the appliance as necessary.

Fig. 2. Water flow diagram.



- |                                  |   |
|----------------------------------|---|
| 1 Safety Discharge               | 10 Bi-thermal Gas to Water Heat Exchanger |
| 2 C.H. Flow                      | 11 Domestic Water Flow Turbine            |
| 3 Domestic Hot Water Out         | 12 Pressure Relief Valve                  |
| 4 Domestic Cold Supply           |   |
| 5 C.H. Return                    |   |
| 6 Fixed By-pass                  |   |
| 7 Circulating Pump               |   |
| 8 Sealed System Expansion Vessel |   |
| 9 Automatic Air Vent             |   |

The data plate is fixed to the inner casing cover.

### 3. Technical Data

Table 1.

NOMINAL BOILER RATINGS (10 Minutes After Lighting)				
BOILER ADJUSTED FOR G20 (Natural Gas)				
OUTPUT	INPUT (Net)	BURNER PRESSURE	GAS RATE	
kW	kW	m bar.	m <sup>3</sup> /h	
8.5	10.5	1.0	1.11	*
10.5	13.5	1.5	1.38	**
27.5	30.0	13.5	3.17	

Natural Gas: Net Input = Gross Input x 0.901

\* Hot water setting - manual adjustment

\*\*Central heating setting - non adjustable

Table 2.

FLUE DETAILS		
HORIZONTAL FLUE		mm
WALL HOLE DIAMETER	EXTERNAL FIX	110
	INTERNAL FIX	150
STANDARD FLUE	MINIMUM LENGTH	330/425 *
	MAXIMUM LENGTH	725
EXTENDED FLUE	MAXIMUM LENGTH	2500
FLUE ASSEMBLY DIAMETER		100

\* NOTE : Flue lengths between 330 and 425mm require the flue to be cut

Table 3

MAXIMUM AVAILABLE PUMP HEAD			
BOILER OUTPUT kW	HEAD Metres	MIN. FLOW RATE L/min.	FLOW/RETURN DIFFERENTIAL °C
10.5	4.19	13.7	11
27.5	2.0	27.5	14

Table 4

MECHANICAL SPECIFICATIONS	
CENTRAL HEATING FLOW - COMPRESSION	22mm
RETURN - COMPRESSION	22mm
COLD WATER INLET - COMPRESSION	15mm
DOMESTIC WATER FLOW - COMPRESSION	15mm
GAS INLET	Rp ½
RELIEF VALVE DISCHARGE (PUSH FIT)	15mm
CASING HEIGHT	800mm
CASING WIDTH	450mm
CASING DEPTH	360mm
WEIGHT - LIFT	42.3kg
WEIGHT - UNPACKED (DRY)	45.8kg
WEIGHT - PACKAGED	52kg

**Table 5**

PERFORMANCE SPECIFICATIONS			
PRIMARY WATER CAPACITY		litres	3.0
MAXIMUM MAINS INLET PRESSURE		bar	10
MINIMUM MAINS INLET PRESSURE (WORKING) FOR MAXIMUM FLOW		bar	0.9
MINIMUM MAINS INLET PRESSURE (WORKING) FOR OPERATION		bar	0.1
MAXIMUM CENTRAL HEATING FLOW TEMPERATURE		°C	82 (nom)
MAXIMUM CENTRAL HEATING SYSTEM PRESSURE (OPERATING)		bar	2.5
MINIMUM CENTRAL HEATING SYSTEM PRESSURE		bar	0.5
OUTPUT TO DOMESTIC HOT WATER	kw	NATURAL GAS (G20)	8.5 - 27.5
OUTPUT TO CENTRAL HEATING	kw	NATURAL GAS (G20)	10.5 - 27.5
DOMESTIC HOT WATER SPECIFIC RATE - D 30°C RISE		l/min	13.1
MAXIMUM DOMESTIC HOT WATER FLOW RATE - 40°C RISE		l/min	9.8
NO <sub>x</sub> CLASSIFICATION			Class 2
SEDBUK NUMBER			78.1
SEDBUK BAND			D
BURNER INJECTOR		mm	4.5

**Table 6**

DOMESTIC HOT WATER TEMPERATURE RISE					
DISCHARGE RATE l/min		7	8	9	10
TEMPERATURE RISE °C		56	49	44	39

**Table 7**

GAS SUPPLY SYSTEM					
Gas Discharge Rate (m <sup>3</sup> /hr)	Total length of gas supply pipe (metres)				Pipe size (Ømm)
	3	6	9	12	
	Natural Gas				
	8.7	5.8	4.6	-	22
	18.0	12.0	9.4	-	28

**Note:** Each fitting used in the gas line from the meter is equivalent to a length of straight pipe which must be added to the straight pipe length to give total length.

i.e: Bend = 0.5 metre, Tee = 0.5 metre, 90° Bend = 0.3 metre.

**Table 8**

	CLEARANCES (mm)	
	INSTALLATION	SERVICE
ABOVE APPLIANCE AND/OR FLUE ELBOW	30	30
IN FRONT OF APPLIANCE	600	600
BENEATH APPLIANCE	200	200
RIGHT AND LEFT HAND SIDE	10	10

Refer to Section 6.

**Table 9**

SYSTEM CAPACITY			
TOTAL SYSTEM VOLUME litres			
INITIAL PRESSURE bar	INITIAL CHARGE PRESSURE bar		
	0.5	1.0	1.5
1.0	57	75	N/A
1.5	31	42	52

**Fig. 3. Appliance casing dimensions and required clearances (front view).**

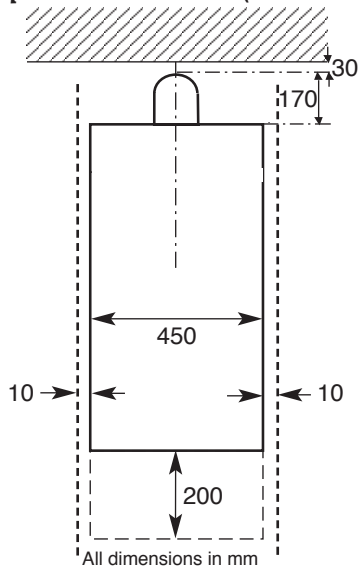

**Fig.4. Appliance casing dimensions and required clearances (side view).**

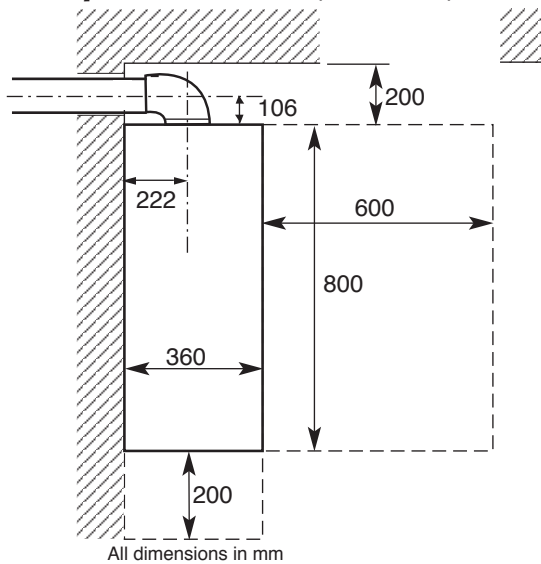

**Fig. 5. Side flue opening**

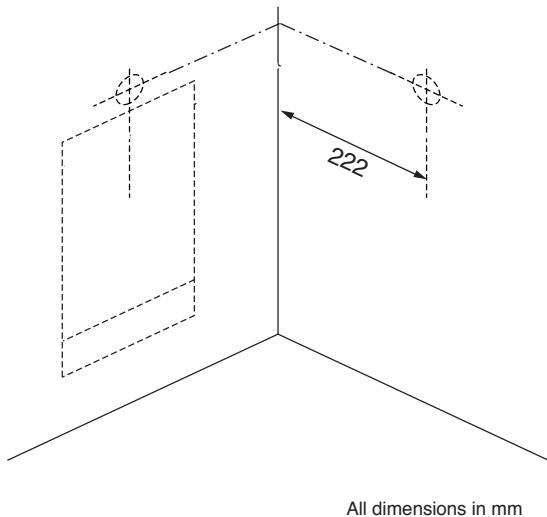

## 4. Siting The Appliance

4.1 The appliance may be installed in any room but refer to the requirements of the current IEE Wiring Regulations BS 7671 and, in Scotland, the electrical provisions of the Building Regulations applicable in Scotland, with respect to the installation of appliances in rooms containing baths or showers.

Where a room sealed appliance is installed in a room containing a bath or shower, any electrical switch or appliance control using mains electricity must **NOT** be able to be touched by a person using the bath or shower.

4.2 The appliance is **NOT** suitable for external installation.

4.3 **NO** special wall protection is required.

4.4 The wall must be capable of supporting the weight of the appliance. See Table 4.

4.5 The specified clearances must be available for installation and for servicing. See Fig. 3 and 4. (note the clearances at the front are for a removable panel e.g. a door).

4.6 The appliance can be installed in a cupboard used for airing clothes provided that the requirements of BS 6798 and BS 5440:2 are followed.

Notwithstanding the instructions given in BS 5440:2, this appliance may be fitted in a compartment with no vents as long as the minimum clearances stated in Section 6: Air Supply, are maintained.

4.7 The airing space must be separated from the boiler space by a perforated non-combustible partition. Expanded metal or rigid wire mesh are acceptable provided that the major dimension is less than 13mm. See BS 6798:1987.

4.8 No combustible surface must be within 75mm of the casing. See BS476:4.

4.9 Always consider the possible need to disconnect the pipes from the appliance after installation.

**Fig. 6. Appliance pipework connections.**

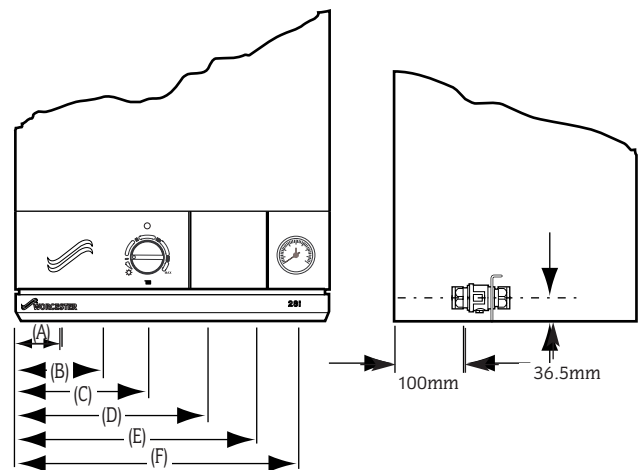

A Safety Relief	=	50mm
B CH Flow	=	95mm
C DHW Out	=	160mm
D Gas Inlet	=	225mm
E Mains Cold Water In	=	290mm
F CH Return	=	355mm

## 5. Siting The Flue

- 5.1 The flue must be installed as specified in BS 5440:Part 1.
- 5.2 The terminal must not cause an obstruction nor the discharge cause a nuisance. Refer to Fig. 7.
- 5.3 If a terminal is fitted less than 2 metres above a surface to which people have access then a guard must be fitted. The guard must be evenly spaced around the terminal and fixed with plated screws. A type K2 guard is available from Tower Flue Components, Vale Rise, Tonbridge, TN19 1TB.
- 5.4 The terminal guard must be evenly spaced about the flue terminal and fixed to the wall using plated screws.
- 5.5 In certain weather conditions a terminal may steam and siting where this could cause a nuisance should be avoided.
- 5.6 Take care to ensure that combustion products do not enter ventilated roof voids.
- 5.7 The standard flue kit is horizontal and extends from 425 to 725mm in length. It can be shortened to 330mm (for single brick wall applications) by cutting the flue ducts if required. Extension kits are available for flue lengths up to 2500mm. A vertical flue system for heights upto 2.3m plus the terminal assembly. Refer to Table 2.
- 45° and 90° bends are available.

## 6. Air Supply

- 6.1 A separate vent for combustion air is not required.
- 6.2 The appliance can be fitted in a cupboard with no vents for cooling but the minimum clearances must be increased to those given below (note the clearances at the front are for a removable panel e.g. a door).

Above the Turret	30mm
In front	250mm
Below	200mm
Right-hand side	75mm
Left-hand side	75mm

- 6.3 If the appliance is to be fitted in a cupboard or compartments with less clearance than those above (minimum clearances given in Section 4. Siting The Appliance) then permanent vents for cooling are required. One at high level and one at low level, either direct to outside air or to a room. Both vents must pass to the same room or be on the same wall to the outside air.

- 6.4 The minimum free areas required are given below.

- 6.5 Refer to BS 6798 and BS 5440:2 for additional information.

POSITION OF AIR VENTS	AIR FROM THE ROOM	AIR DIRECT FROM OUTSIDE
HIGH LEVEL	300cm <sup>2</sup>	150cm <sup>2</sup>
LOW LEVEL	300cm <sup>2</sup>	150cm <sup>2</sup>

Fig. 7. Siting of the flue terminal.

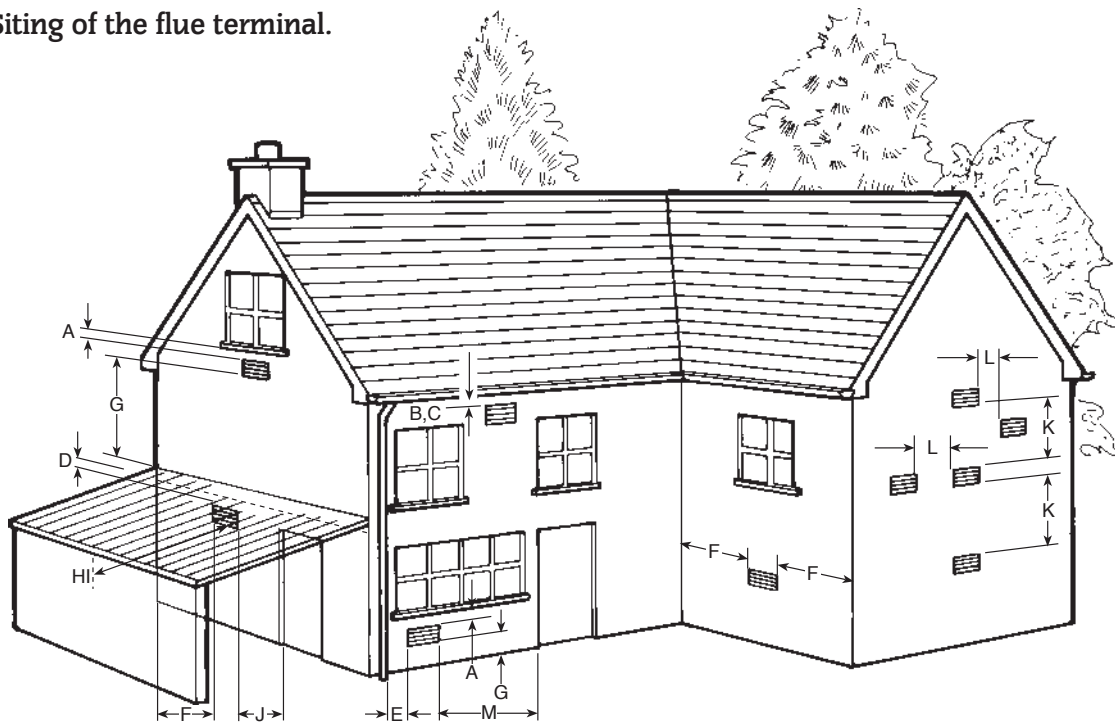

TERMINAL POSITION	MIN. DISTANCE	TERMINAL POSITION	MIN. DISTANCE
A- directly below an openable window or other opening e.g. air brick.	300mm	I- From a terminal facing a terminal	1200mm
B- Below gutters, soil pipes or drain pipes.	75mm	J- From an opening in a car port (e.g. door window) into dwelling.	1200mm
C- Below eaves.	25mm	K- Vertically from a terminal on the same wall.	1500mm
D- Below balconies or car port roof.	25mm	L- Horizontally from a terminal on the same wall.	300mm
E- From vertical drain pipes and soil pipes.	25mm	M- From door, window or air vent	300mm
F- From internal or external corners.	25mm		
G- Above ground, roof or balcony level.	300mm		
H- From a surface facing a terminal.	600mm		

## 7. Sealed System

7.1 The system must comply with the requirements of BS 6798 and BS 5449 and the appliance must not be operated without the system being full of water, properly vented and pressurised.

7.2 The pressure relief valve operates at 3 bar (45lb/in<sup>2</sup>). The discharge must be directed away from electrical components or where it might be a hazard to the user.

7.3 The pressure gauge indicates the system pressure which must be maintained.

7.4 The 8 litre expansion vessel is charged to 0.5 bar and is suitable for a static head of 5 metres (17.5ft). The pressure can be increased if the static head is greater than 5 metres (17.5ft).

7.5 With an initial system pressure of 0.5 bar, a system capacity of up to 100 litres can be accommodated. For system capacities greater than this an extra expansion vessel must be fitted. Refer to BS 7074 Pt. 1 for more information. The charge pressure can be increased but with a consequent decrease in system volume.

7.6 The filling point must be at low level. Refer to Fig. 8.

7.7 Water loss must be replaced. See Fig 4. The connection should be made in the central heating return as close to the appliance as possible. A filling loop kit is supplied.

7.8 Repeated venting loses water from the system. It is essential that this water is replaced and the system pressure maintained.

7.9 Connections to the mains water supply must not be made without the authority of the local Water Company.

7.10 The pump is set at maximum and should not be adjusted.

7.11 Connections in the system must sustain a pressure of up to 3 bar.

7.12 Radiator valves must conform to BS 2767:10.

7.13 Other valves used should conform to the requirements of BS 1010.

7.14 The appliance is fitted with a fixed internal by-pass. But it is advisable to keep one radiator permanently open.

## 8. Open Vent System

The appliance is **NOT** suitable for connection to an open vented system.

Fig. 8. Sealed primary water system.

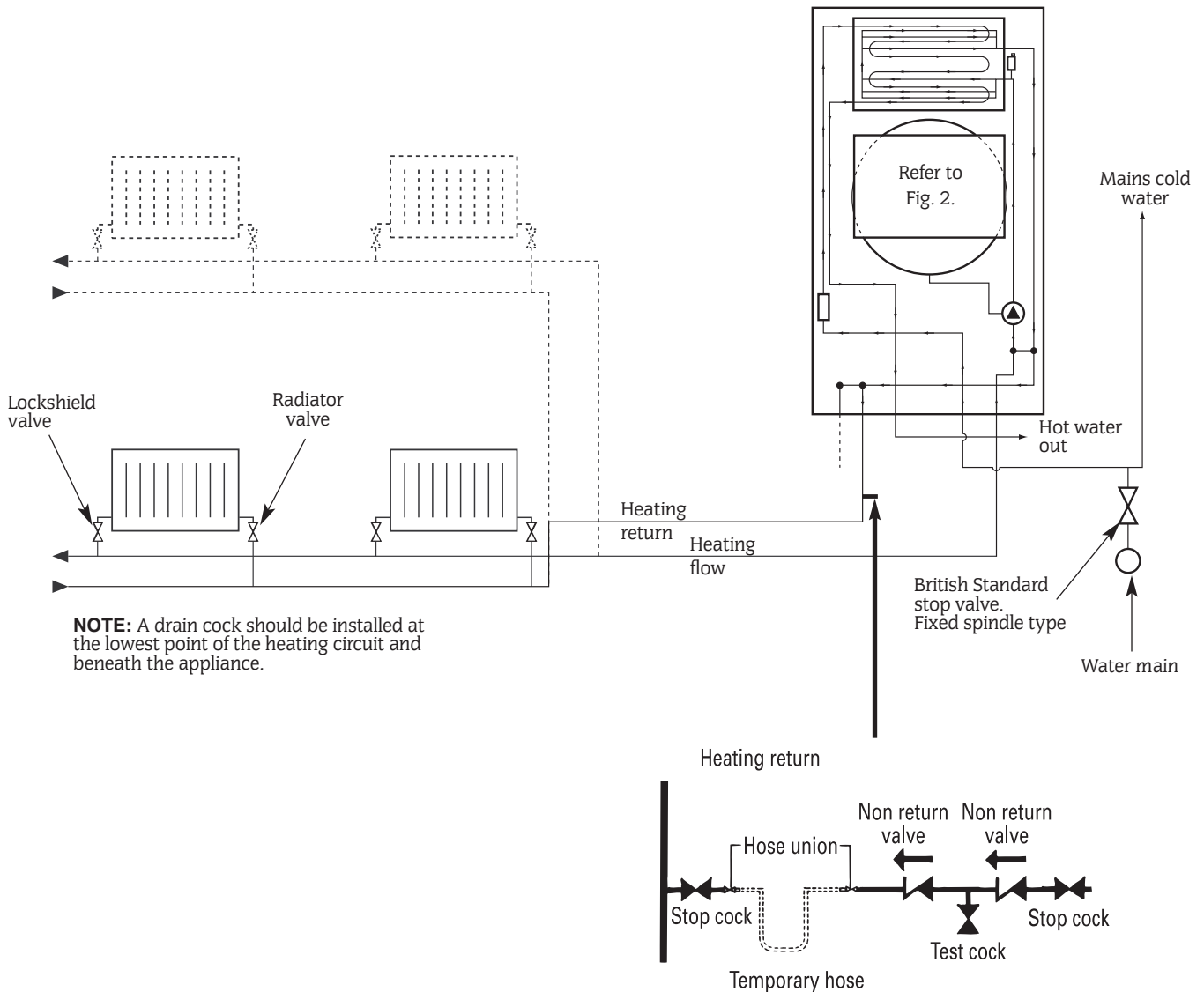

## 9. Domestic Hot Water

9.1 The following are general requirements and, if necessary, reference should be made to the local Water Company before fitting the appliance.

**9.2 MAINS COLD WATER INLET. Devices capable of preventing the flow of expansion water must not be fitted unless separate arrangements have been made.**

A mini expansion vessel kit is available which contains the necessary parts for fitting an internal expansion vessel to the appliance.

Refer to Section 19.

A thread sealant compatible with potable water must be used. An external expansion vessel may be fitted on the mains cold water connection to the appliance.

9.3 The final 600mm of the mains cold water connection to the appliance should be made in copper tube only.

9.4 The appliance is suitable for a mains pressure of up to 10 bar (150 lb/in<sup>2</sup>) and is fitted with a mains supply isolating valve.

9.5 The maximum domestic hot water flow rate is 11.4 litres/min ( $\pm 15\%$ ).

9.6 In winter (when the mains inlet water temperature is lower) a reduced flow rate at the taps may be required to achieve the type of hot water delivery temperature available in warmer weather.

9.7 It is suggested that long pipe runs to the taps or shower should be insulated to prevent the rapid cooling of domestic hot water after a tap or shower has been turned off.

9.8 Hot and cold taps and mixing valves used with this appliance must be suitable for operating at mains pressure and temperatures of 55°C.

**Note:** The maximum domestic hot water outlet temperature is fixed at 55°C and it is not adjustable.

9.9 No anti-syphonage arrangements are necessary except for some loose head showers. See also Section 9.11 following.

9.10 Thermostatically controlled or pressure equalising shower valves will guard against the flow of water at too high a temperature.

9.11 The head of a loose head shower must not fall closer than 25mm (1in.) above the top edge of the bath to prevent its immersion in bath water. Alternatively the shower must be fitted with an anti-syphonage device at the point of the flexible hose connections.

9.12 The supply of hot and cold mains water direct to a bidet is permitted, (subject to local water company requirements), provided that the bidet is of the over-rim flushing type. The outlet(s) should be shrouded and unable to have any temporary hand held spray attached. No anti-syphonage arrangements are necessary.

**9.13 LIME SCALE. In temporary hard water areas (more than 350mg/litre or 200ppm calcium bicarbonate) it is recommended that a proprietary scale reducer is fitted in the mains cold water connection to the appliance. Consult the local water company for additional advice.**

Installation of a scale inhibitor assembly should be in accordance with the requirements of the local water company. An isolating valve should be fitted to allow servicing. The water hardness can be determined by reference to the local water company.

9.14 **NOTE: HOT WATER ONLY.**

If required the appliance may be used for Hot Water only before the Central Heating is connected. A 22mm copper bypass pipe at least 4 metres long must be connected between the Central Heating Flow and Return, but it is advisable to connect a small radiator instead.

**IT IS NOT RECOMMENDED TO USE THE BOILER IN THIS CONDITION FOR EXTENDED PERIODS.**

## 10. Gas Supply

The boiler requires 3.17m<sup>3</sup>/h (112ft<sup>3</sup>/hr) of natural gas with a calorific value of 37.78MJ/m<sup>3</sup>. The meter governor should deliver a dynamic pressure of 20 mbar (8in w.g.) at the appliance, equivalent to a pressure of 19-19.5 mbar at the gas valve on natural gas.

The gas meter and supply pipes must be capable of supplying this quantity of gas in addition to the demand from any other appliances being served. The table below gives an indication of limiting gas pipe lengths and the allowance to be made for fittings. Refer to BS6891 for further information.

The complete installation, including the gas meter, must be tested for soundness and purged. Refer to BS6891.

# 11. Electrical

## 11.1 MAINS SUPPLY.

230 V ~, 50 Hz, 180 watts.

External Fuse: 3A. Internal Fuses: 2A SLOW (F1), and 1A FAST(F2).

Spare fuses are supplied with the appliance and are fixed adjacent to the pressure gauge.

11.2 It must be possible to completely isolate the appliance.

11.3 The following connection alternatives must be used:

A 3 amp fused three-pin plug and unswitched shuttered socket outlet (both complying with the requirements of BS 1363) or a double pole isolator with a contact separation of 3mm in all poles and supplying the appliance and controls only.

11.4 The appliance must be earthed.

11.5 Mains Cable. 0.75mm<sup>2</sup> (24 x 0.20mm) to BS 6500 Table 16. The mains cable must be connected into the terminal X1, marked L (Brown or Red lead), N (Blue or Black lead) and the earth stud and be held securely in the cable clamp. For access undo the three bottom screws and remove the facia access cover. See Fig. 11. The earth lead must be slack when the others are taut.

11.6 The wiring between the appliance and the electrical supply shall comply with current IEE Wiring Regulations and any local regulations which apply.

11.7 If a room thermostat and/or external programmer is to be fitted refer to Figs 12 and 13. The devices must be suitable for use with mains voltage.

11.8 A facia mounted mechanical programmer is available as an optional extra. Instructions are supplied with the programmer kit.

11.9 A time switch or programmer can be fitted externally to the appliance.

11.10 The boiler provides automatic frost protection, the use of a frost thermostat is not recommended. However if an external frost thermostat is considered necessary then it must be used in conjunction with a programmer.

**Important:** To provide external frost protection the appliance **must** have the Central Heating Temperature Control Knob set to supply heating (the appliance may then be left with the central heating turned off at the programmer).

Connection must be made at X2 terminals RI and CL. refer to Fig. 28. For advice on external frost thermostats contact Worcester Heat Systems Technical Helpline

## 11.11 SAFETY CHECK.

After installation or in the event of an electrical fault the electrical system shall be checked for short circuits, fuse failure, incorrect polarity of connections, earth continuity and resistance to earth.

Fig. 9. Wiring diagram.

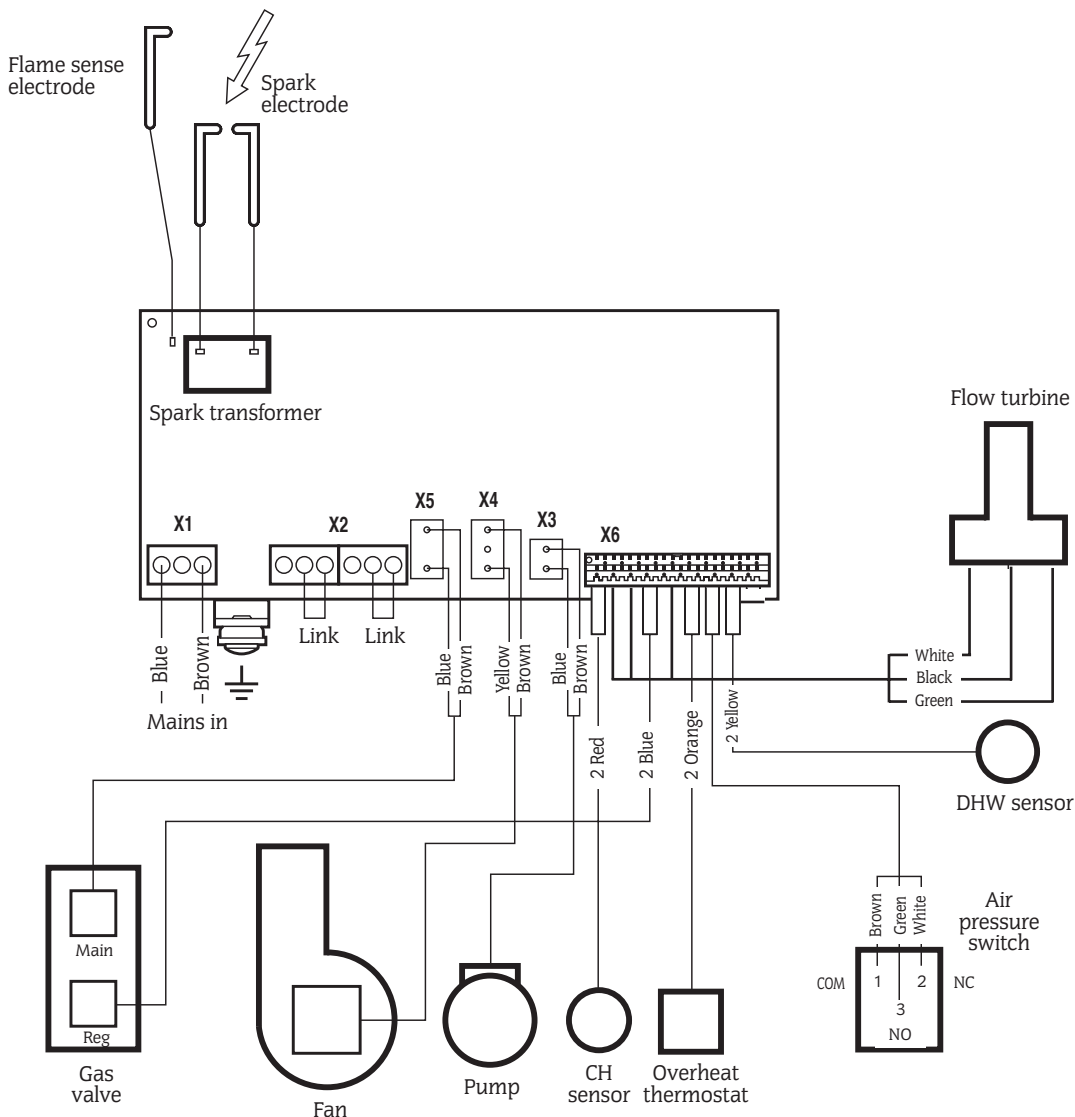
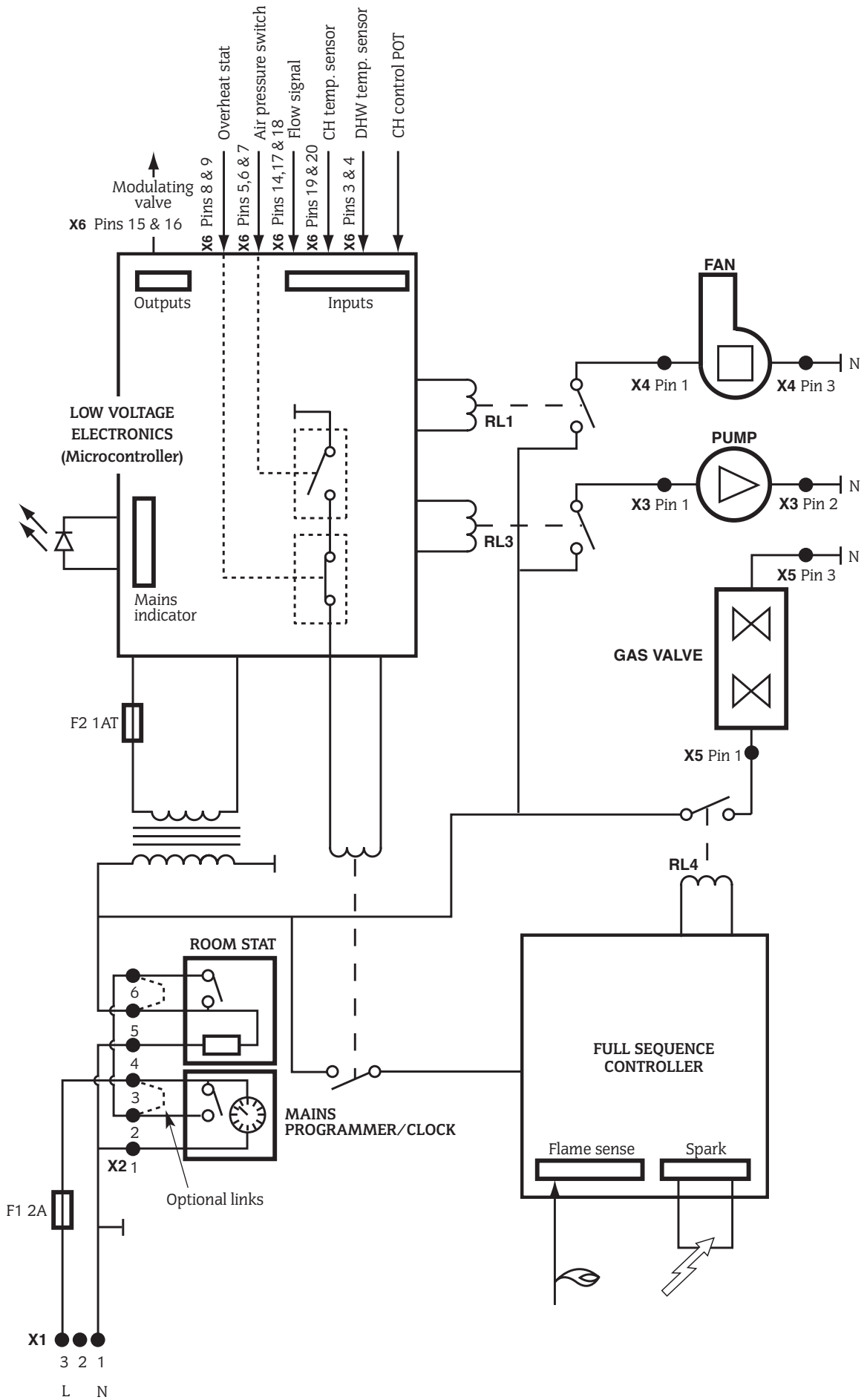
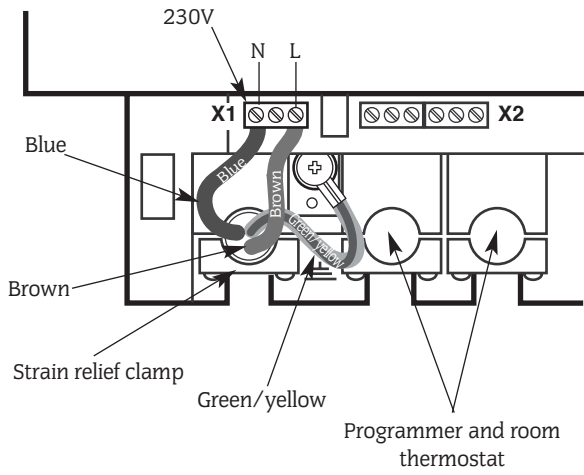

Fig. 10. Functional flow diagram.



**Fig. 11. Mains electricity connections.**



**Fig. 12. 230V room thermostat connections.**

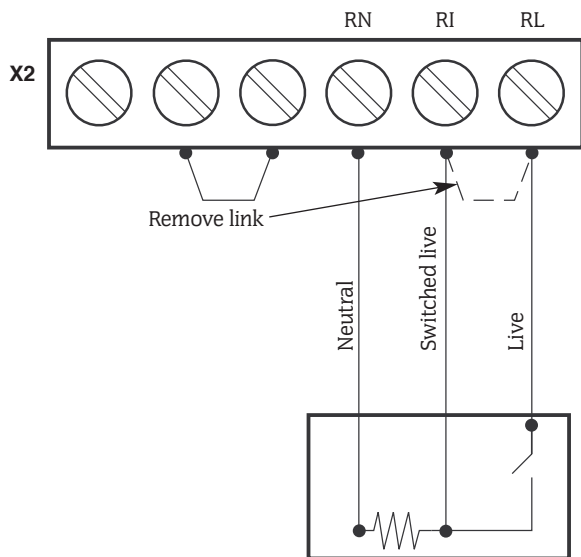

**Fig. 13. 230V programmer connections.**

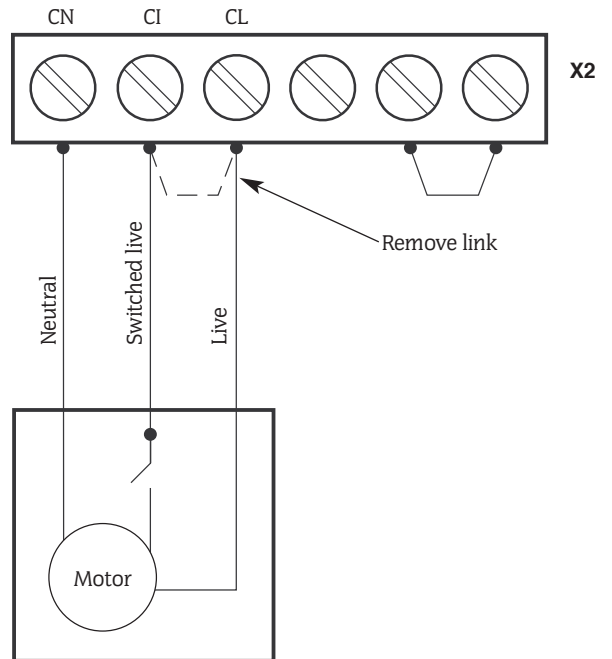

## 12. Installing The Appliance

**Note: READ THIS SECTION FULLY BEFORE COMMENCING INSTALLATION.**

### 12.1 General

The appliance is only suitable for fitting to a sealed system. The flue must be installed as specified in BS5440:1. Check that the appliance is suitable for the local conditions. i.e. gas supply.

### 12.2 Unpacking

Remove the appliance from its packaging and check the contents against the packing list.

### 12.3 Site Preparation

Check the correct position for the appliance has been chosen. Refer to Section 4 and Table 8. Check that the wall is flat and will support the weight of the appliance. Refer to Table 4.

### 12.4 Fixing Holes and Flue Opening

Hold the template against the wall. Check that the template is level. Mark the position of the fixing holes and the flue opening. Refer to Fig. 14 and 15.

Mark the centre-lines of the pipe connections to aid the pre-plumbing of the system pipework.

Check the position of the fixing points and the flue opening before drilling the fixing holes 60mm deep for the No.12 size plugs and cutting the flue duct hole at 110mm diameter (150mm diameter for internally fitted flues).

### 12.5 Wall Mounting Plate and Manifold

Fit the plugs and fix the top support to the wall. Refer to Fig. 14. Check the top support is properly aligned before tightening the screws.

### 12.6 Gas and Water Pipes

Remove the gas cock and fix the appropriate fitting to connect the inlet pipe and re-fit.

Pre-plumbing is not recommended if no movement in the pipes is available. If it is necessary for the pipes to run up the back of the appliance then they must be arranged to pass behind the expansion vessel. Pipework must not run horizontally within the limits of the casing. It is important that the pipes are not fixed near the appliance using clips that put a strain on the connections.

**(benchmark)** Before the appliance is fitted to the wall thoroughly flush the system and mains water supply.

**Fig. 14. Appliance mounting plate and flue position.**

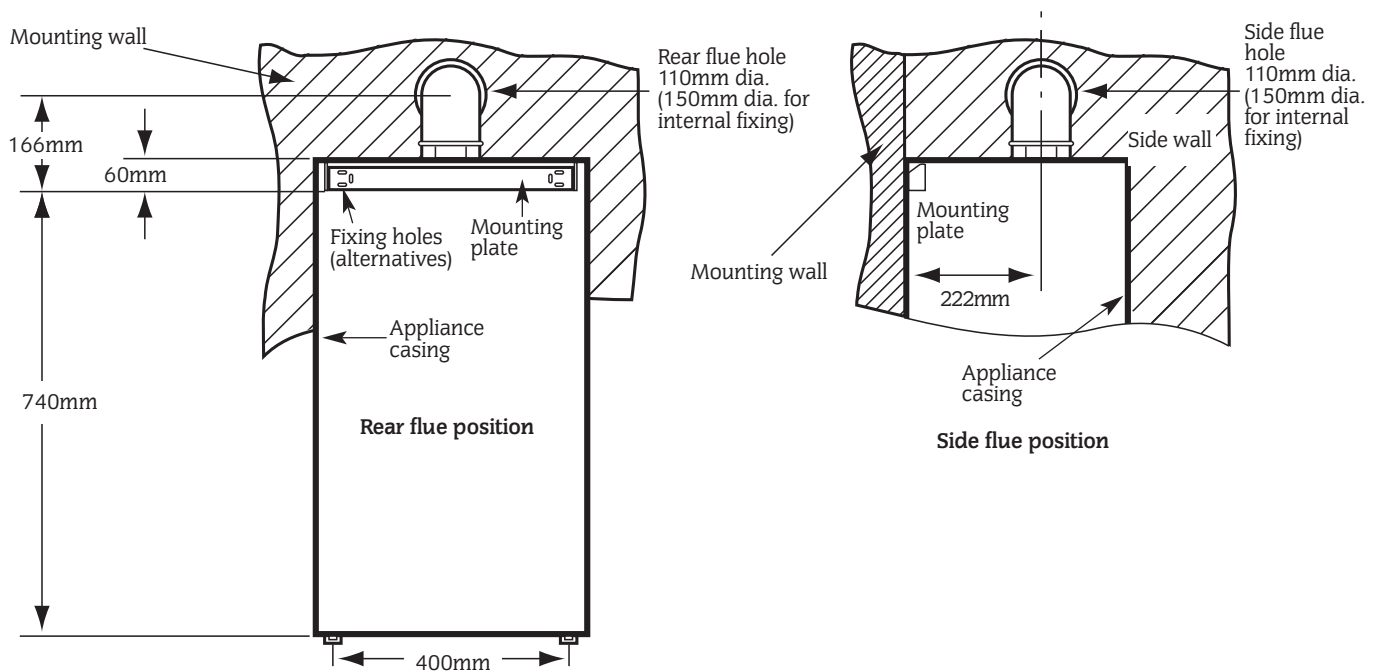

**Fig. 15. Marking out the side flue position.**

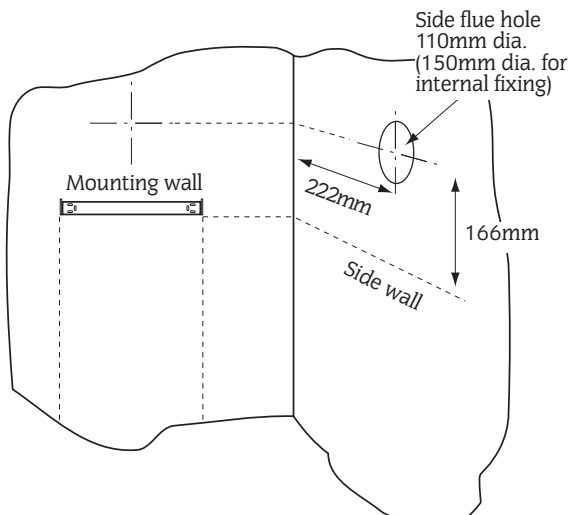

### 12.7 Install the Boiler

Remove the cabinet by releasing the sides and lifting from the top location.

Check that the gas and water valves are closed.

Lift the appliance to the wall, engage in the top support. Fix and tighten the bottom screws. Refer to Fig. 14.

Tighten the gas and water connections.

Fit a discharge pipe to the relief valve leading it away from any electrics or where it might be a hazard.

The pipe must not be less than 15mm in diameter and must run continuously downward outside the appliance. Refer to Fig. 6.

**Fig.16. Appliance casing and control equipment fixings.**

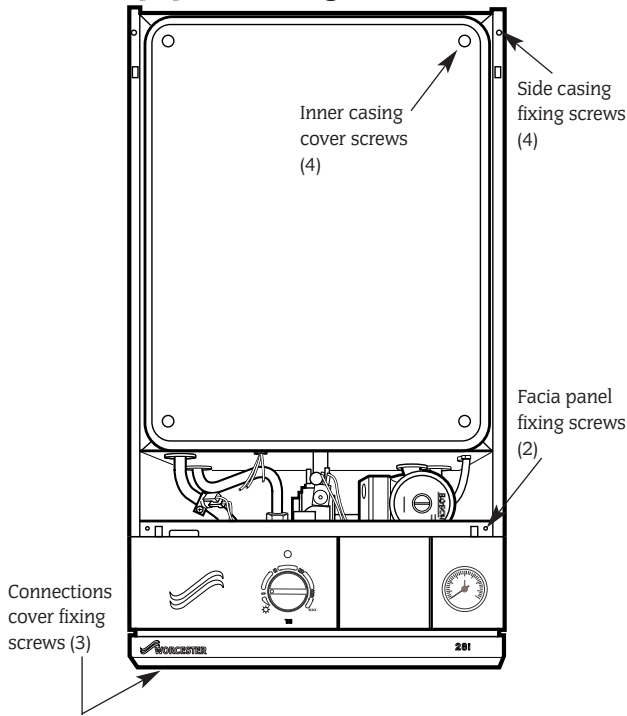

**12.8 Air and Flue Duct Preparation**

The method of installation of the flue system may be varied to suit the actual site conditions. The instructions for connecting and fixing the ducts must, however, be strictly followed.

Remove all packing material from the flue components.

**Horizontal Flues up to 725mm Length**

Fit the flue restrictor ring by unscrewing the flue spigot from the boiler. Refer to Fig. 17.

**Fig.17. Flue turret fixing and automatic air vent.**

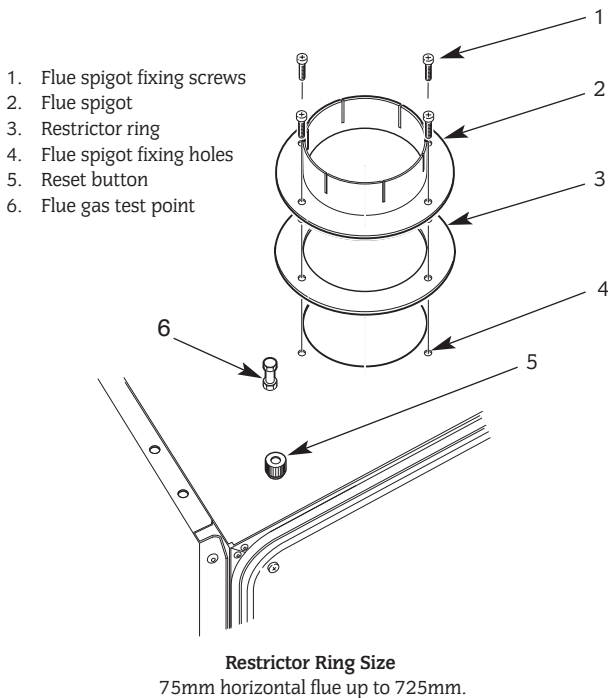

The standard telescopic flue assembly is suitable for flues from 425mm (without cutting) up to 725mm measured from the centre-line of the boiler flue outlet to the outer face of the wall. Refer to Fig. 18.

If L is greater than 725mm then flue extension kits will be required - each kit extends the flue by 750mm up to a maximum of 2.5m. See table below.

EXTENSION	MAXIMUM FLUE LENGTH mm
1	1475
2	2225
3	2500

**12.9 Measure and Cut the Ducts**

**General:** Cut the ducts as necessary, ensuring that the ducts are square and free from burrs. Always check the dimensions before cutting.

Measure the distance L. Refer to Fig. 20 and 21 .

The standard flue can be telescopically adjusted to any length between 425mm and 725mm.

Fix the flue assembly together using the self-tapping screw provided. Refer to Fig. 18.

It will only be necessary to cut the standard assembly if L is less than 425mm. Cut the flue turret assembly and the terminal assembly by the same amount i.e L= 350 - remove 75mm from each assembly.

Minimum side flue length = 335mm (accommodating a 10mm Service clearance and a 100mm wall)

Minimum rear flue length = 322mm (accommodating a 100mm wall)

If L is between 1175 - 1475mm (1 extension)  
1925 - 2225mm (2 extension)

it is not necessary to cut the ducts.

**Fig.18 . Standard flue assembly.**

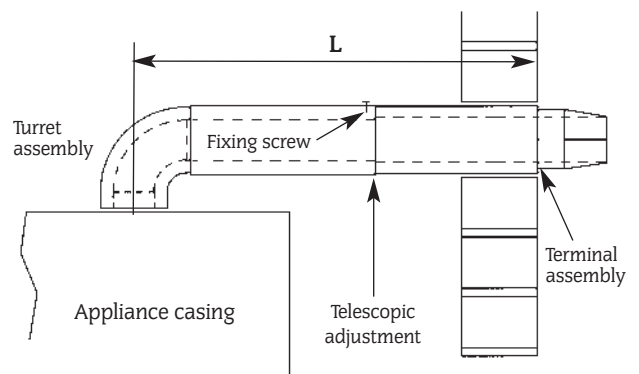

Fig. 19. Extension Duct.

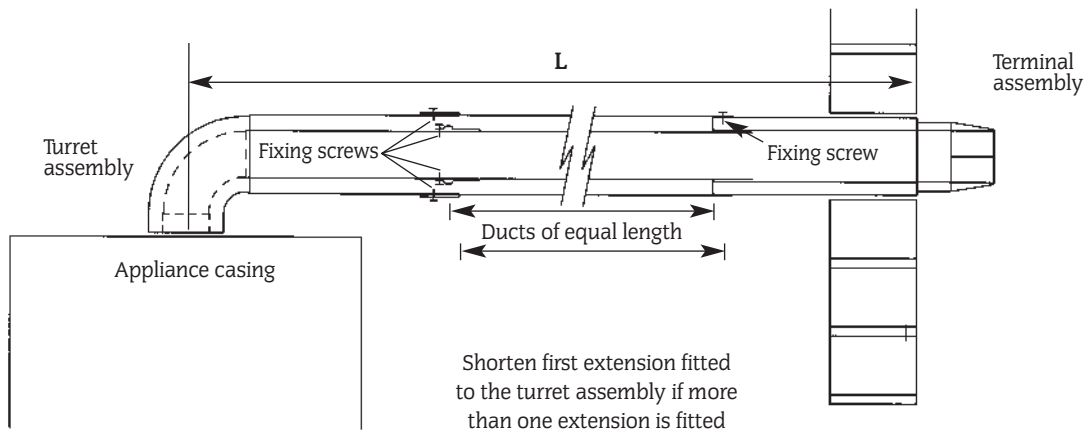
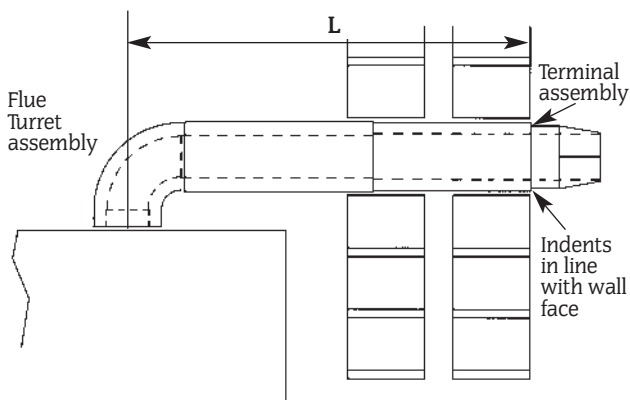

Fig. 20. Flue duct length (side flue).



If L is between:

725 - 1175mm	(1 extension)
1475 - 1925mm	(2 extension)
2225 - 2500mm	(3 extension)

it is necessary to shorten the assembly by cutting the first extension duct assembly i.e.  $L = 1000\text{mm}$  - remove 175mm from the air and flue ducts.

NOTE: Extension duct measurements do not include the socketed end. Unless specifically instructed the socketed end must not be removed.

Fix the flue ducts together before fixing the surrounding air duct, the cut ducts fit into the flue assembly.

**12.10 Fitting the Flue Assembly with Access to the Terminal**

Prepare the flue duct assembly as described in Section 12.9.

Apply the plastic tape to the air duct in contact with the external brickwork.

From inside push the assembly through the wall. Align the flue turret and push fully onto the spigot on the appliance. Tighten the clamping ring and fix with the screw provided. Refer to Fig. 22.

Fig. 21 . Rear flue.

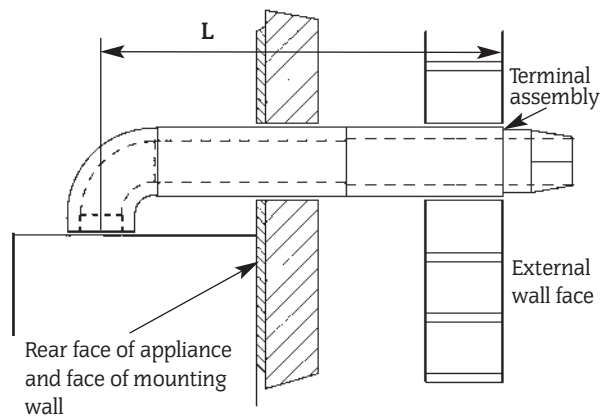

Make good the internal wall face and the external brickwork or rendering.

Replace the inner casing.

**12.11 Fitting of the Flue Assembly without access to the Terminal**

A rubber gasket kit is available from Worcester Heat Systems. NOTE: A larger diameter opening in the wall is required. Refer to Table 2.

Prepare the flue assembly as described in Section 12.9.

Fit the rubber sealing gasket centrally onto the terminal assembly and tighten the clamp. Refer to Fig. 23.

Apply the plastic tape to the air duct in contact with the external brickwork.

From inside push the assembly through the wall so that the gasket flange is against the outer face. Refer to Fig. 23.

It may be necessary to adjust the legs of the flue centering ring. Align the flue turret and push fully onto the socket on the appliance. Tighten the clamping ring and fix with the screw provided. Refer to Fig. 22.

Seal the gap around the duct at the inner wall face with the flexible seal provided and make good.

Replace the inner casing.

**Fig. 22. Flue Turret Fixing .**

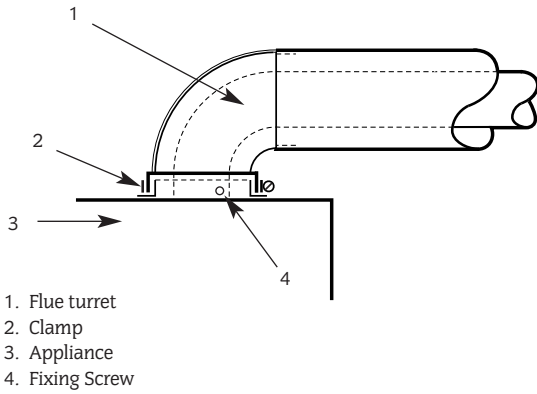

**12.12 Flue Bends**

90° and 45° bends are available. A maximum of two bends may be used in addition to the first bend on the flue turret. A 90° bend is equivalent to 750mm of straight duct. A 45° bend is equivalent to 375mm of straight duct.

**Fig. 24. Flue bends.**

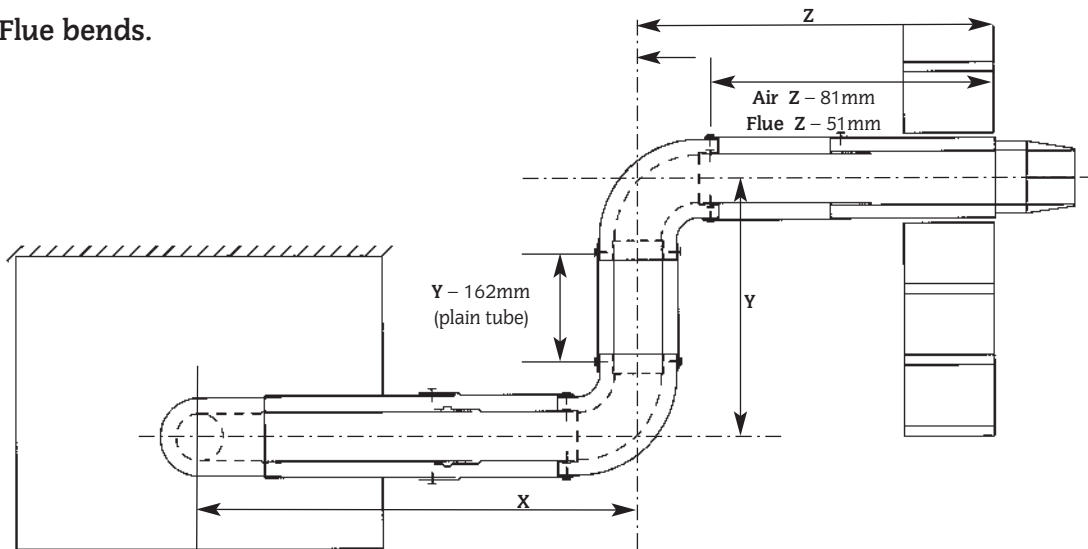

A maximum flue assembly of 2.5m is possible with 1 X 90° bend and 2m with 2 X 90° bends.

Measure the lengths X,Y and Z. Refer to Fig. 24.

The maximum value of X using the turret assembly only in 506mm. Reduce the ducts to the appropriate length i.e. X = 406mm, cut 100mm from the air duct and 120mm (to cover the entry into the 45° or 90° elbow) from the flue duct. Refer to Fig.24.

NOTE: The flue system ducts between the elbows, dimension Y, requires the socketed ends (of the first extension if two or more are used) to be removed and the air and flue tubes to be cut to the same length.

Cut the ducts to a length Y - 162mm. Refer to Fig. 24.

The final section, dimension Z, of the flue system must include a section of plain duct assembly i.e. an extension assembly with the sockets removed. Reduce the final section, including the terminal assembly, by the appropriate amount i.e. Air duct Z - 81mm and the flue duct Z - 51mm. Refer to Fig. 24.

If Z < 425mm it will be necessary to cut the air and flue ducts of the extension to a plain length of 100mm and reduce the length

**Fig. 23. Terminal assembly for internal fitting of the flue.**

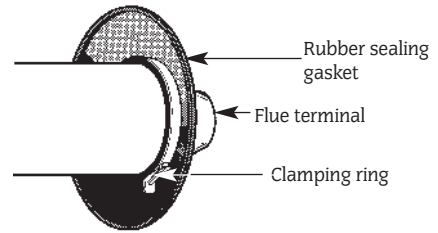
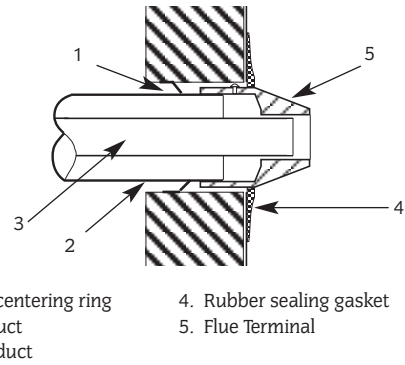

of the terminal assembly i.e Z = 350mm - remove 75mm from the terminal assembly.

If Z in 425 - 725mm it is not necessary to cut the terminal assembly or use a second extension duct as the length can be set telescopically.

If Z > 725mm then two extension duct assemblies will be required, the first assembly being cut to length as plain tubes.

If more than two extension ducts are needed in any section to achieve the required length then the final section of the assembly must not be less than 325mm without cutting the terminal assembly.

NOTE: The flue duct of the final extension must be 30mm longer than the air duct.

Each section must be connected to the previous section of the flue bend by fixing the flue ducts together and then similarly fixing the air ducts which engage the elbows.

Fit the assembly as described in Section 12.10, 12.11 as appropriate.

Make good the internal and external brickwork or rendering.

**Fig. 25 - Elbow to Flue Turret Assembly.**

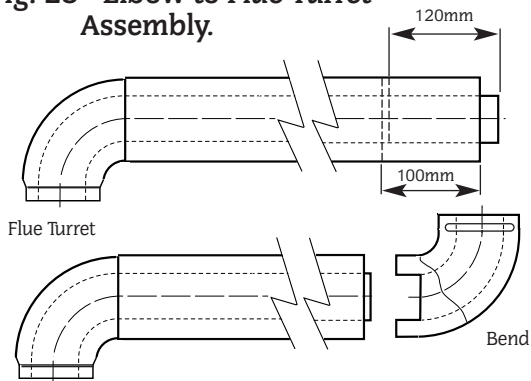

**Fig. 26 Vertical Adapter.**

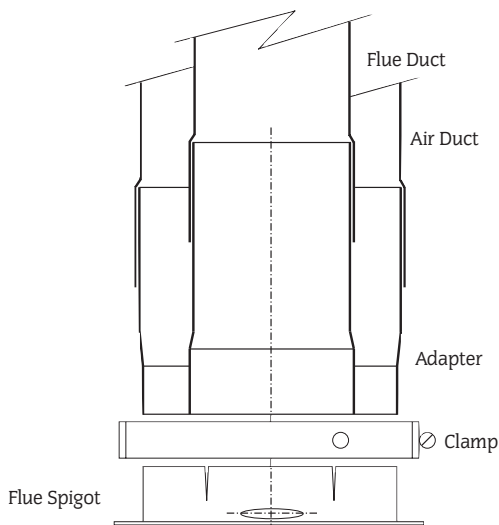

**12.13 Vertical Adapter for Horizontal Flues**

An adapter is available for an initial short section of vertical flue. Refer to Fig. 26.

Measure and cut the flue as described in Section 12.12.

The first, vertical, section (equivalent to dimension X) is measured from the top of the boiler casing. Cut the vertical section of the extension duct to 167mm less than the measured distance. Do not remove the socketed ends.

The minimum measured distance is 167mm.

Seal the air duct to the turret using silicone sealant.

Fix the adapter with the clamp and screw provided.

**Fig. 27 - Facia Connections Cover.**

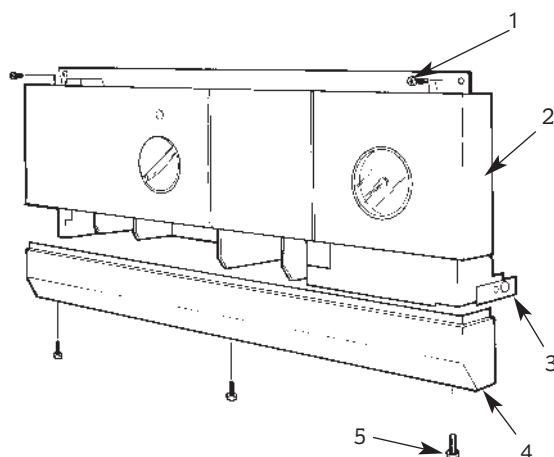

1. Control Panel Fixing Screws
2. Facia
3. Control Panel Pivot Point
4. Connection Cover
5. Connection Cover Fixing Screws

**12.14 Completion of the Installation**

Check that all the connections on the appliance have been tightened.

Remove the facia bottom panel. Refer to Fig. 27.

Connect the mains electricity supply lead to the appliance and secure the cable clamp. Refer to Fig. 27. and 28.

Check there is sufficient loose lead to allow the release of the facia panel assembly and that the earth lead of the mains supply cable is longer than the live and neutral leads.

Fit the facia mounted clock. Full instructions are sent with the programmer. Refer to Fig. 28. and 29.

Connect any external controls ensuring that the leads pass through the appropriate clamps. Refer to Fig.18.

Test for gas soundness as described in BS6891.

If the appliance is not to be commissioned immediately, replace the cabinet and facia bottom panel. Check that the gas and electricity services have been turned off.

**Fig. 28 -**

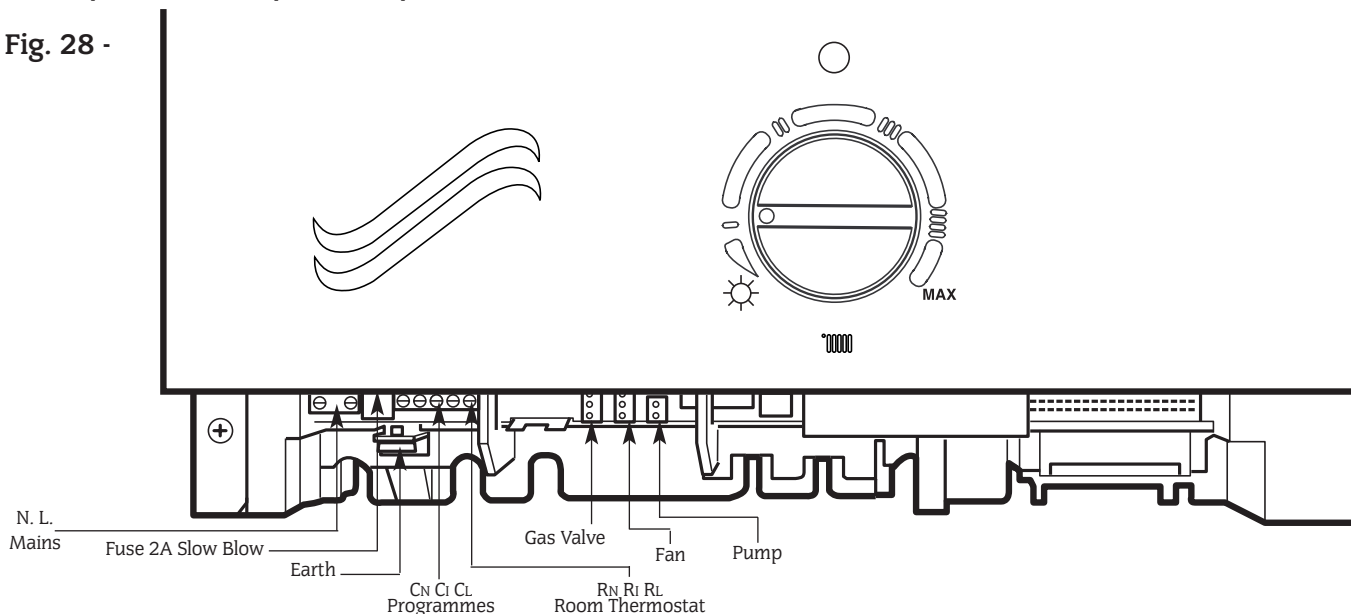

**Fig. 29 - Programmer Connection - Facia Position**

1. Programmer
2. Programmer Fixing Clip
3. Pressure Gauge
4. Programmer Connector

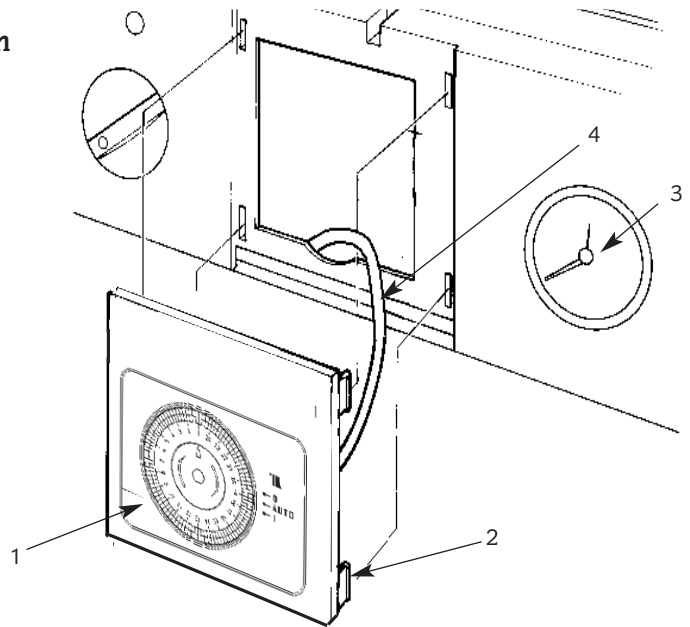

## 13. Commissioning



**Benchmark Water Treatment:** For optimum performance after installation, this boiler and its associated central heating system should be flushed in accordance with the guidelines given in BS7593:1992 - Treatment of water in domestic hot water systems. Full instructions are supplied with proprietary cleansers sold for this purpose. If an inhibitor is to be used after flushing, it should be used in accordance with the inhibitor manufacturers instructions.

Suitable flushing agents and inhibitors are available from Betz Dearborn Tel: 0151 4209563 and Fernox Tel: 01799 550811. Instructions for use are supplied with these products.

### 13.1 Remove the appliance cabinet

Check that the electrical supply and the gas supply to the appliance are turned off and that all the water connections throughout the system are tight.

Open the system valves at the appliance. Refer to Fig.6 .

Remove the automatic air vent cap. Refer to Fig. 30 .

Fill the system through the external filling loop. Refer to Section 7, Sealed System.

Vent each radiator in turn.

The automatic air vent will vent the appliance.

Remove the cap from the pump and turn the shaft about a half turn.

Replace the cap. Refer to Fig. 31.

Switch on the electricity supply (not the gas) and set the controls to give continuous operation in the CH mode.

When the air is expelled turn off the electrical supply and the CH control to off.

Check the pressure relief valve operates by turning the knob anti-clockwise until it releases.

Lower the facia to gain access to the relief valve. Refer to Fig. 32.

Water should be expelled from the discharge pipe.

### 13.2 Set the Expansion Vessel Pressure

The charge pressure of the expansion vessel as despatched is 0.5bar, which is equivalent to a static head of 5m (17ft).

The charge pressure must not be less than the static head at the point of connection.

A Schraeder type valve is fitted to the expansion vessel to allow the discharge pressure to be increased if necessary.

The expansion vessel must be charged to 0.35bar less than the initial system design pressure.

**Fig. 30. Appliance components and fixings (upper assembly).**

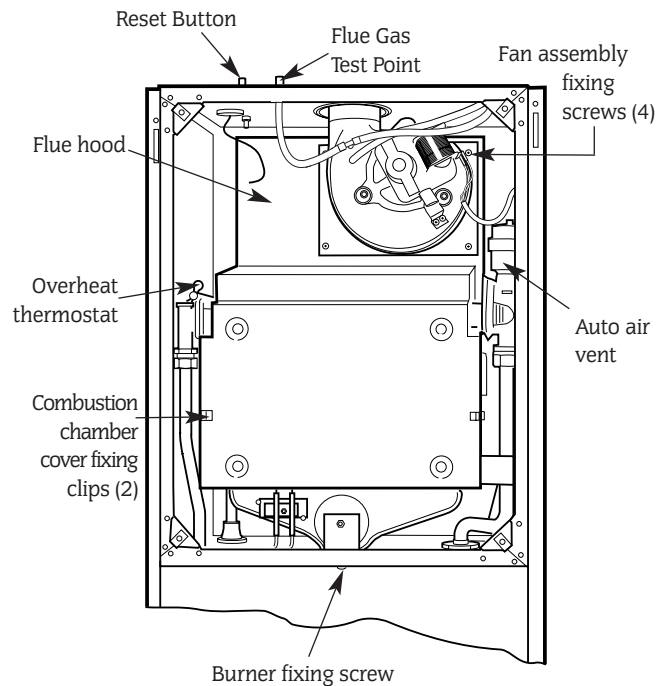

**Fig. 31. Pump venting.**

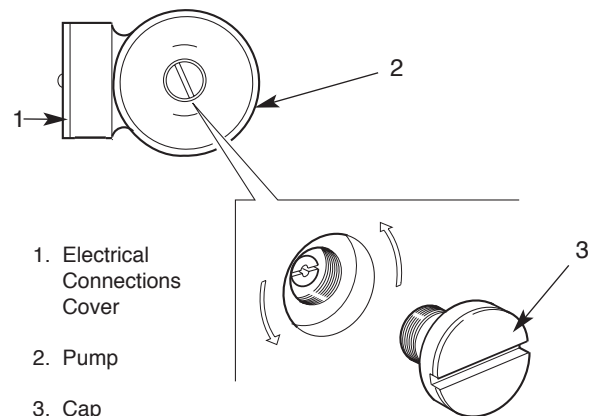

Note: 1 bar = 10.2m = 33.5ft of water.

### 13.3 Set the System Pressure

Fill the system until the pressure gauge is at 2.5 bar and check for leaks.

Release water from the system using the relief valve test knob until the required system pressure is obtained, upto a maximum of 1.5 bar.

Set the pointer on the pressure gauge to record the set system pressure.

If the pressure indicated on the gauge is greater than 2.65 bar when operating at the maximum central heating temperature, an extra expansion vessel must be fitted to the system as close as possible to the appliance central heating return connection.

The appliance (as despatched) can accommodate a system volume of 100 litres. Refer to BS7074 Part 1, BS5449 and table 8.

If the system volume is greater than an extra vessel must be fitted as close as possible to the appliance central heating return connection and pressurised to the same figure as the integral vessel.

Fig. 32. Pressure relief valve.

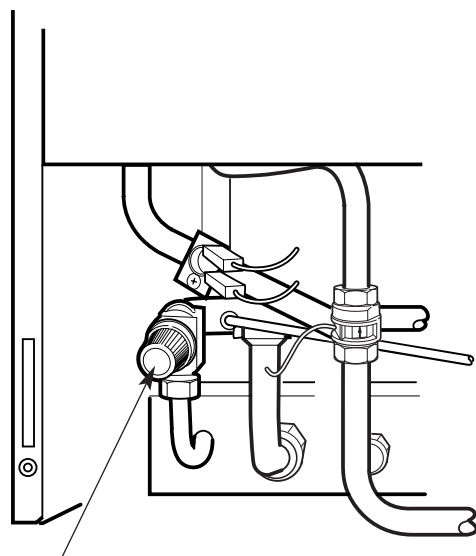

Pressure relief valve.  
(Turn knob anti-clockwise to test).

### 13.4 Clock/Programmer

The controls fitted to the appliance should be set up at this stage.

### 13.5 Operation

Check that the gas and electricity supplies are turned off.

Connect a pressure gauge to the gas valve inlet and outlet pressure test points. Refer to Fig. 33.

Set the temperature control to maximum and the clock/programmer to operate continuously.

Turn on the gas and electricity supplies.

Turn on a hot tap to give a maximum flow rate.

A continuous spark will occur until the burner is alight and sensed by the control circuit.

The burner will remain at its maximum domestic hot water pressure. Refer to Table 1.

It should not be necessary for the gas valve to be adjusted. Refer to Section 16.4.11.

**Note:** The burner pressure is factory set and if, after checking that the dynamic (working) supply pressure is sufficient i.e 19-19.5 mb approx, at the gas valve inlet pressure test point, the correct pressure cannot be obtained then Worcester Heat Systems Service Department should be contacted.

If the appliance does not light then check that it is not in the 'Lock-out' state by pressing the reset button. Refer to Fig. 34.

Turn off the hot tap.

The burner pressure will drop to the minimum CH setting and will ramp up to the maximum central heating pressure.

Fig. 33. Gas valve.

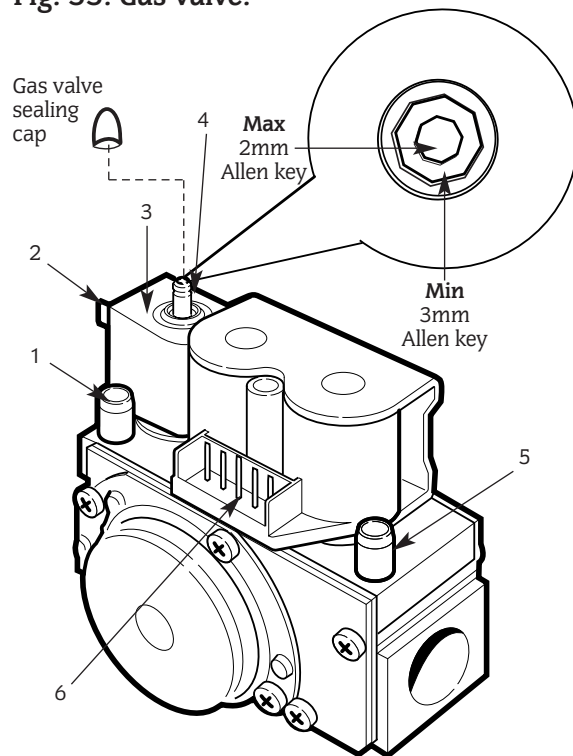

- 1 Burner pressure test point
- 2 Electrical connections – modulator (Blue : Blue)
- 3 Modulating solenoid
- 4 Minimum / Maximum pressure adjuster - Allen key  
**Note:** Clockwise to increase and anti-clockwise to decrease the pressure
- 5 Inlet pressure test point
- 6 Main gas valve connections

It should not be necessary for the gas valve to be adjusted. Refer to Section 16.4.11.

Switch the appliance **off** and then **on** to reset the control.

The burner pressure will remain at the minimum CH pressure for a period. Refer to Table 1.

It should not be necessary for the gas valve to be adjusted. Refer to Section 16.4.11.

Test for gas soundness at the joint between the burner and the gas valve with leak detection fluid.

**Turn the electricity supply off then back on to reset the controls.**

### 13.6 Domestic Hot Water

Turn the central heating temperature control knob fully anti-clockwise.

Open a hot tap near the appliance.

The burner will light and go to the maximum burner pressure appropriate to the appliance and the gas. Refer to Table 1.

Gradually close the tap and check that the burner pressure falls.

Fully close the tap and check that the burner goes out.

The fan will continue running until the appliance has cooled to a pre-set temperature.

### 13.7 Central Heating

Check that all the radiator valves are open.

Check that the system is pressurised and set to the required pressure as indicated on the gauge.

Check that the clock/programmer is set to operate continuously. Set the room thermostat and the central heating control to maximum.

The burner will light and the appliance will modulate its output from minimum to satisfy the required heating load.

Check that all the radiators are heating up evenly.

Shut down all but one of the radiators and observe the burner pressure fall.

Open all the radiators and check that the burner pressure rises.

13.8 Balance the system to give a temperature differential of 11°C or 13°C. A non-adjustable by-pass is fitted to the appliance. Refer to Table 3.

13.10 Set the room thermostat to minimum and check that the burner goes out.

Reset the room thermostat to maximum and the burner will re-light and follow the normal operating procedure.

Turn off the gas service cock.

The burner will go out but sparking from the electrode will continue for 10 seconds when the appliance will 'Lock-out'.

After 60 seconds **carefully** open the gas service cock.

Switch mains electricity off and on and observe the burner re-light and follow the normal sequence of operation.

Turn off the gas service cock and electricity supply to the appliance.

Drain the system while the appliance is hot.

Refill, vent and re-pressurise the system as described in Section 13.1 preceding, adding, if necessary, a suitable proprietary inhibitor. Further information is available from Betz Dearborn, 0151 4209563 or Fernox 01799 550811.

### 13.11 Domestic Hot Water and Central heating

Set all controls to maximum.

Turn on the electricity supply to the appliance and open the gas service cock at the appliance.

The burner will light and heat will pass into the system.

Turn on a hot tap and check that hot water is soon discharged from the tap. Close the tap and the burner will go off.

The appliance will then return to the central heating mode and automatically balance with the system requirements.

### 13.12 Completion of Commissioning

Disconnect the pressure gauge and tighten the test point screw.

Refit the cabinet.

If the appliance is to be passed over to the user immediately then set the controls to the users requirements.

If the appliance is to be left inoperative in frosty conditions then set the programmer, if fitted, to off.

Do not turn electricity or gas supplies off.

The appliance will operate under the control of the integral frost protection facility.

If there is any possibility of the appliance being left totally unused in freezing conditions then switch off the gas and electricity supplies and drain the appliance and system.

## 14. Handover

**benchmark** 14.1 Tell the user how to operate the appliance and hand over the Users Instructions leaflet.

14.2 Tell the user what to do if the heating system is not to be used in frosty weather.

14.3 Tell the user the sealed system set pressure.

14.4 Tell the user of the importance of regular servicing. Worcester Heat Systems Ltd. offer a comprehensive maintenance contract.

14.5 Set the system controls to the user's requirements.

14.6 **Complete and hand over to the user the Benchmark Log-Book.**

Fig. 34. User controls.

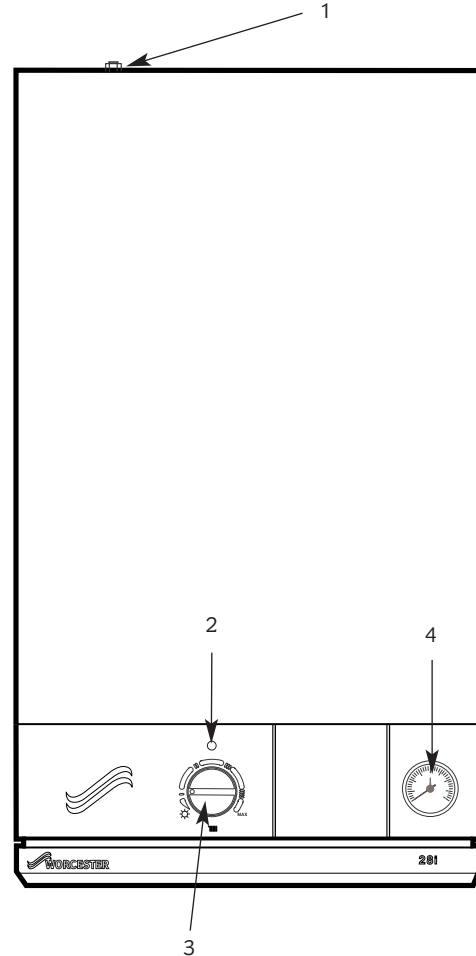

- 1 Reset Button
- 2 Mains Indicator
- 3 C.H. Temperature Control
- 4 System Pressure Gauge

## 15. Inspection And Service

### **benchmark** 15.1 SERVICING

To ensure continued efficient operation of the appliance it must be checked and serviced as necessary at regular intervals. The frequency of servicing will depend upon the particular installation conditions and usage, but once per year should generally be adequate. The extent of the service required by the appliance is determined by the operating condition of the appliance when tested by fully qualified engineers.

Any service work must be carried out by competent engineers such as British Gas or Corgi registered personnel.

### 15.2 PRE-SERVICE INSPECTION

Check that the flue terminal and the terminal guard, (if fitted), are clear.

If the appliance is in a compartment, check that the ventilation openings in the compartment door or walls are clear. See Section 6 - Air Supply.

Check the system and remake any joints or fittings which show signs of leakage.

Refill, vent and re-pressurise as described in Section 13.2.

Operate the appliance and the system taking note of any faults.

### Measurement of the Flue Gases

For consistency of results of the flue gas measurements it is necessary to have a constant output and for the appliance to be at equilibrium.

Turn on a tap to create a hot water demand.

Wait until the appliance reaches thermal equilibrium (approx. 10 minutes).

Remove the test point sealing screw on the appliance top panel. See Fig. 17 and 30.

Connect to the test point with a piece of tubing.

Expected measurements should be between:

<b>For Natural Gas:</b>	<b>7.0 - 7.5%</b>	<b>Carbon Dioxide</b>
	<b>0.003 - 0.007%</b>	<b>Carbon Monoxide</b>

After taking the measurement replace the sealing cap.

### IMPORTANT

Disconnect the electrical supply at the mains and turn off the gas supply at the gas service cock on the appliance before servicing.

After completing the service always test for gas soundness as indicated in BS 6891.

### 15.3 DISMANTLE THE APPLIANCE

To carry out a full and comprehensive service of the appliance remove the following parts to gain access to the components which need to be checked or serviced.

**(a) Cabinet Front Panel.** Remove by lifting off the supports.

**(b) Inner Casing Cover.** Check that the electricity supply to the appliance is turned off. Remove the cabinet front panel. Unscrew the four screws securing the cover to the casing and lift off. See Fig. 35.

**(c) Facia Panel.** Check that the electricity supply to the appliance is turned off. Remove the cabinet front panel. Unscrew the two upper screws as shown in Fig. 35. and hinge down the facia taking care not to damage the pressure gauge capillary tube or electrical connections.

**(d) Bottom panel.** Unclip and remove the appliance bottom panel.

**(e) Fan.** Remove the inner casing cover as detailed in Section 15.3(b) above. Carefully unplug the electrical connections and pull off the sensing tubes. Unscrew the four fixing screws and remove the fan assembly. See Fig. 36.

**(f) Combustion Chamber Front.** Remove the inner casing cover. Undo the spring clips fixing the combustion chamber front taking care not to damage the insulation on removal. See Fig. 36.

**(g) Flue Hood Assembly.** Remove the fan assembly as described in Section 15.3(e). Remove the combustion chamber front taking care not to damage the insulation. Lift and slide the flue hood assembly from the appliance. See Fig. 36. When refitting the hood ensure that the rear return edge passes under the lip at the rear of the combustion chamber.

Fig.35. Appliance casing and control equipment fixings.

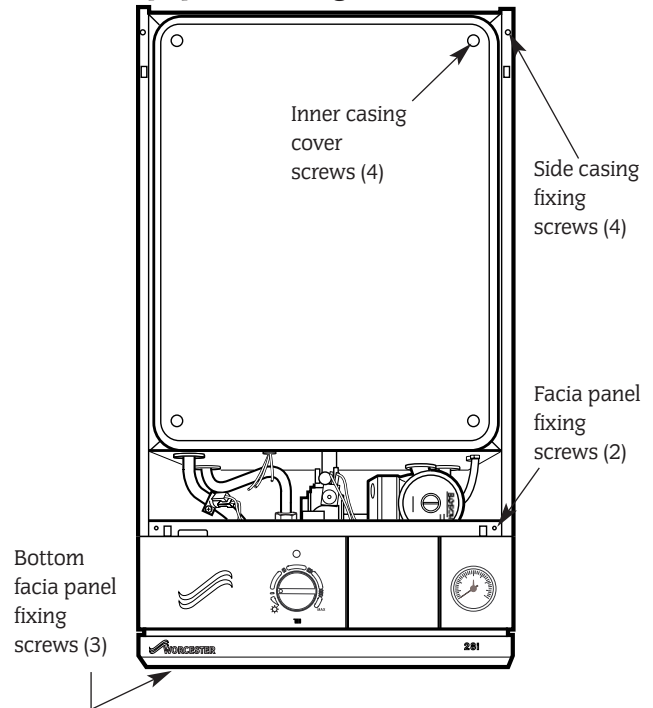
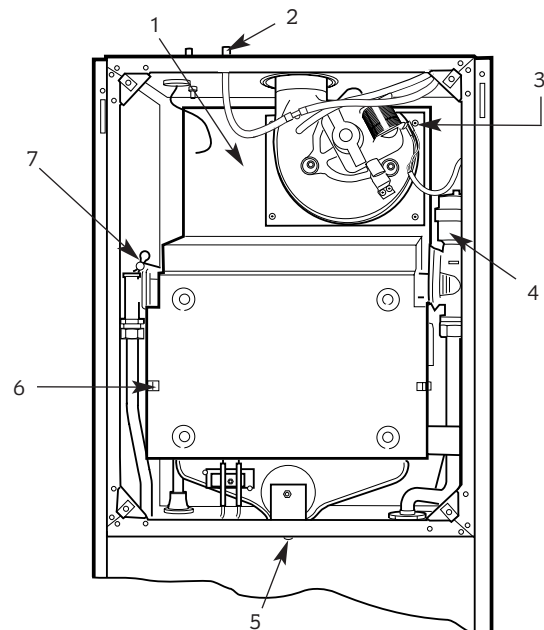
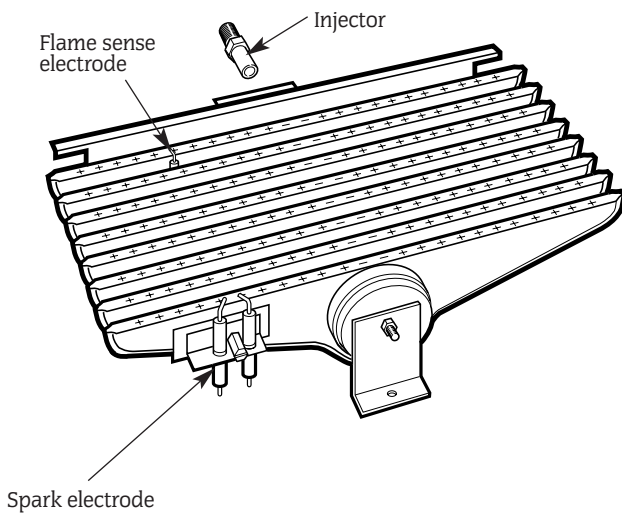

Fig. 36. Appliance components and fixings (upper assembly).



- 1 Flue hood
- 2 Flue Gas Test Point
- 3 Fan assembly fixing screws (4)
- 4 Auto air vent
- 5 Burner fixing screw
- 6 Combustion chamber cover fixing clips (2)
- 7 Overheat thermostat

**Fig. 37. Burner and electrode assembly.**



**(h) Burner Assembly.** Remove the combustion chamber front as described in Section 15.3(f). Pull off the two spark electrode leads, disconnect the flame sense lead at the connector and remove the grommet. Undo the burner fixing screw. Lift up and remove the burner assembly from the appliance. See Fig. 37

#### 15.4 SERVICE OF COMPONENTS

**Clean the Fan.** Any dust or fluff should be removed with a soft brush or by blowing. Take care not to distort the pressure sensing device.

**Clean the Main Burner.** Brush the blade tops and mixing tube with a soft brush and check that all the flame ports are clear. Remove any blockages with a non-metallic brush. Inspect the injector and clean with a soft brush. Replace the injector if it appears damaged. Do not use a wire brush or anything likely to cause damage. Replace the spark and sense electrodes if they appear damaged.

**Clean the Gas to Water Heat Exchanger.** Clean the heat exchanger using a soft brush. Remove the deposits from the bottom of the combustion chamber. Do not distort any of the blades.

**Combustion Chamber Insulation.** Examine and replace any pads that are damaged. Remove any dust or deposits using a soft brush.

Re-assemble the appliance in the reverse order.

Check that all components are in place and correctly fixed. Leave the cabinet front panel to be fitted after checking the operation of the appliance.

#### 15.5 TEST THE APPLIANCE

On completion of the service and reassembly of the appliance, check for gas soundness and the correct operation of the appliance as described in Section 13 - Commissioning.

Refit the cabinet front panel and reset the controls to the users requirements.

## 16. Replacement Of Parts

### 16.1 IMPORTANT

Switch off the electricity and gas supplies before replacing any components. After the replacement of any components, check for gas soundness where relevant and carry out functional checks as described in Section 13 - Commissioning

### 16.2 COMPONENT ACCESS

To replace components it is necessary to remove one or more sections of the cabinet and cover plates within the appliance as described in Section 15.3. The fascia panel may also need to be hinged down as described in Section 15.3 (c).

### 16.3 DRAINING THE APPLIANCE

Check that the electricity supply to the appliance is turned off. Before removing any component holding water it is important that as much water as possible is removed from the appliance.

**(a) Central Heating Circuit.** Turn off the central heating flow and return valves at the appliance. Open the pressure relief valve, make sure that the dust cap on the auto air vent is removed. See Fig. 31. Close the pressure relief valve when the flow has stopped. Some water will remain in the expansion vessel, pump and Gas to Water heat exchangers and extra care must be taken when removing these components.

**(b) Domestic Hot Water Circuit.** Turn off the mains cold supply valve at the appliance and open the lowest hot water tap. A quantity of water will remain in the Gas to Water heat exchanger, extra care must be taken when removing this component.

### 16.4 COMPONENT REPLACEMENT

**1. Automatic Air Vent.** See Fig. 36 and 38.

Remove the inner casing cover as described in Section 15.3 (b).

Drain the central heating circuit as described in Section 15.3 (a).

Unscrew air vent from the heat exchanger.

Fit the replacement assembly ensuring thread sealant is applied and the dust cap is removed.

Open the valves and fill and re-pressurise the system as described in Section 13.2.

**2. Air Pressure Switch.** See Fig. 41.

Check that the electricity supply to the appliance is turned off.

Remove the cabinet front panel as described in Section 15.3 (a) and lower the fascia. Section 15.3(c).

Carefully pull off the sensing tubes and the electrical connections from the switch. Remember to note their positions.

Unscrew the two screws behind the Air Pressure Switch and remove the switch from the appliance.

Fit the replacement switch in the reverse order ensuring that the electrical connections have been made to the correct terminals on the switch. Check that the sensing tubes are fitted correctly.

**3. Fan.** See Fig. 36.

Check that the electricity supply to the appliance is turned off.

Remove the fan assembly as described in Section 15.3(e).

Fit the replacement fan in the reverse order.

**4. Overheat Thermostat.** See Fig. 30 and 36.

Check that the electricity supply to the appliance is turned off.

Remove the inner casing cover as described in Section 15.3 (b).

Carefully pull off the two wires from the thermostat head.

Undo the retaining nut on the top of the appliance and remove the retaining clip from the heat exchanger. Carefully withdraw the thermostat from the appliance.

Fit the replacement thermostat in the reverse order ensuring that some heat sink compound is between the thermostat and the heat exchanger.

**5. Gas to Water Heat Exchanger.** See Fig. 38.

Check that the electricity supply to the appliance is turned off.

Drain the central heating circuit and domestic circuits as described in Section 15.3 (a) and (b).

Remove the inner casing cover, fan, flue hood assembly, combustion chamber front, overheat thermostat, automatic air vent and combustion chamber side insulation as described in Sections 15.3 (b, e, f and g), 15.4 and 16.4 (4).

Fit the replacement heat exchanger in the reverse order ensuring that all the fibre washers are correctly fitted and a layer of heat sink compound is on the thermostat.

**Fig. 38. Combustion chamber.**

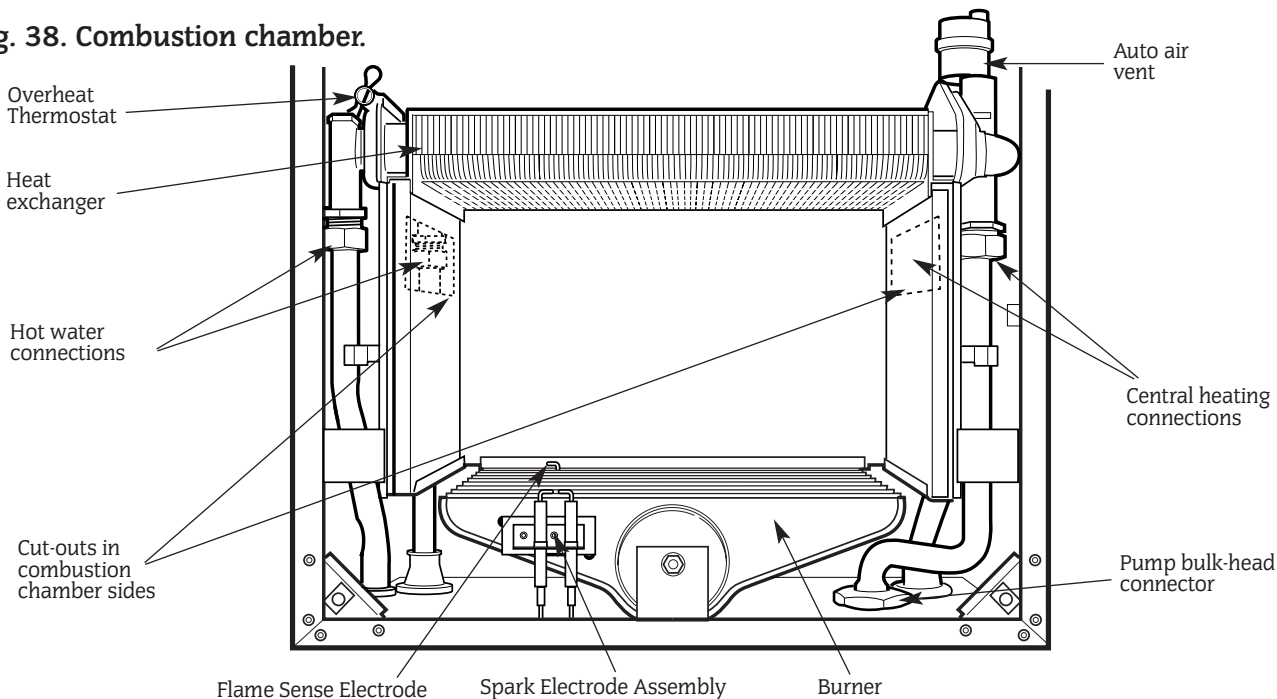

Open the valves and fill and re-pressurise the system as described in Section 13.2.

**6. Combustion Chamber Insulation.**

Check that the electricity supply to the appliance is turned off. If replacing the rear insulation the appliance must be drained as described in Section 16.3(a) and 16.3(b) and the gas to water heat exchanger removed (see 16.4.5).

If changing the front or side pieces it is not necessary to drain the appliance.

Remove the inner casing cover, combustion chamber front, fan and flue hood assembly as described in Sections 15.3 (b,e,f & g). Remove the fibre insulation pads to be changed and fit the replacements taking care not to damage them.

If the system has been drained, open the valves and fill and re-pressurise the system as described in Section 13.2.

**7. Burner.** See Fig. 37.

Check that the electricity and gas supplies to the appliance are turned off. Remove the burner assembly as described in Section 15.3 (h). Fit the replacement burner in the reverse order taking care not to damage the electrode leads.

**8. Burner Injector.** See Fig. 37.

Remove the burner as described in Section 15.3 (h). Unscrew the brass injector from the manifold. Fit the replacement injector in the reverse order.

**9. Spark Electrode Assembly.** See Fig. 39.

Remove the combustion chamber front as described in 14.3 (g). Carefully pull off the two electrode leads, Undo the M4 extended nut and remove the spark electrode assembly from the burner. Fit the replacement electrode in the reverse order, checking that the spark gap is 3.5 to 4.5mm.

**Fig. 39. Spark & flame sense electrode assembly.**

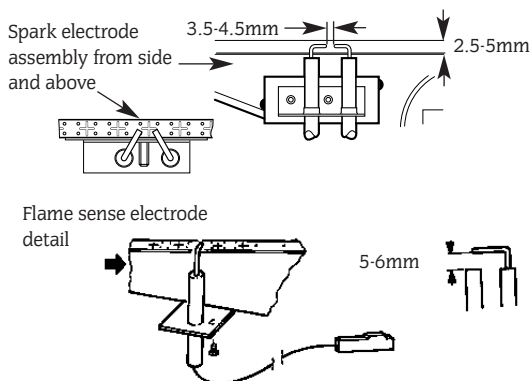

**10. Flame Sensor.** See Fig. 39.

Remove the burner as described in section 15.3(h). Undo the M3 screw and remove the sense electrode from the burner.

Fit the replacement electrode in the reverse order, checking that the sense gap is 5 to 6mm.

**11. Gas Valve.** See Figs. 33. and 40.

Check that the electricity and gas supplies to the appliance are turned off.

Hinge down the control box assembly in the servicing position as described in Section 15.3(c).

**Note:** The adjuster sealing cap should be fitted after setting the burner pressure and coated with a small amount of paint to make any subsequent adjustment obvious.

Whilst supporting the valve unscrew the plug retaining screw and carefully pull off the electrical solenoid plug connection and the two modulare leads.

Undo the 8 manifold screws and remove the gas valve. See Fig. 40. Fit the replacement gas valve in the reverse order ensuring the "O" rings are correctly fitted.

Turn on the gas supply and check for soundness.

**Fig. 40. Gas valve.**

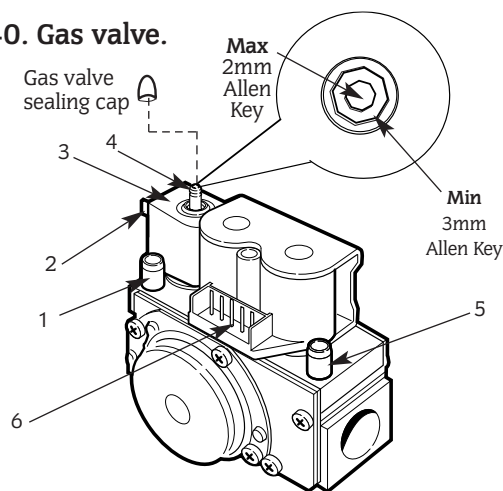

- 1 Burner pressure test point
- 2 Electrical connections – modulator (Blue : Blue)
- 3 Modulating solenoid
- 4 Minimum / Maximum pressure adjuster - Allen key
- 5 Inlet pressure test point
- 6 Main gas valve connections

**Note:** Clockwise to increase and anti-clockwise to decrease the pressure

**To set the burner pressure.** See Fig. 40.

The minimum and maximum burner pressures must be set after a new gas control has been fitted.

The maximum burner pressure must be set first, as any adjustment of the maximum pressure influences the minimum pressure setting.

Start the appliance in the domestic hot water mode as described in section 13.6. - Appliance Operation.

Adjust the maximum pressure adjustment (2mm Allen screw on the gas valve) to give a burner pressure of 13.5 mbar on natural gas. End the demand and reset the appliance by interrupting the mains electricity supply. (Otherwise there is a four minute anti-cycle delay at the end of a demand).

Open a hot tap.

Remove one of the blue leads from the modulating solenoid on the gas valve to ensure that the burner pressure remains at the minimum setting. See Fig. 40.

Adjust the minimum pressure to 1 mbar using a 3mm Allen key. Replace the blue lead and re-check the pressures.

After completing the adjustments, check the minimum and maximum pressures and re-adjust as necessary.

**Re-fit the adjuster sealing cap and coat with a small amount of paint to seal the cap to make any subsequent adjustment obvious.**

**12. Central Heating Sensor.** See Fig. 41.

Check that the electricity supply to the appliance is turned off. Hinge the fascia assembly in the servicing position as described in Section 15.3(c and d).

Carefully pull off the two leads from the sensor.

Pull off the sensor and spring retaining clip from the pipe.

Fit the replacement sensor in reverse order with a layer of heat sink compound between the faces. Refit the leads.

**Fig. 41. Appliance Components (Lower Assembly)**

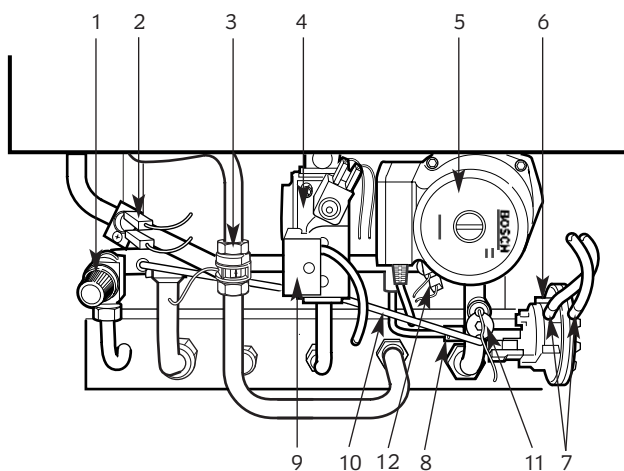

- 1 Pressure relief valve
- 2 Domestic hot water sensor
- 3 Water flow turbine
- 4 Gas valve
- 5 Pump
- 6 Air pressure switch
- 7 Air pressure switch connecting tubes
- 8 Pressure gauge connection
- 9 Gas valve electrical connections
- 10 By-pass pipe
- 11 Fixing disc and screw
- 12 Central heating sensor

**13. Domestic Hot Water Sensor.** See Fig. 41.

Check that the electricity supply to the appliance is turned off. Hinge the fascia assembly in the servicing position as described in Section 15.3(c and d).

Carefully pull off the two leads from the sensor.

Undo and remove the clamping screw.

Pull off the sensor and spring retaining clip from the pipe.

Fit the replacement sensor in the reverse order ensuring a layer of heat sink compound is between the faces. Refit the leads.

**14. Circulating Pump.** See Fig. 41.

Check that the electricity supply to the appliance is turned off.

Drain the central heating circuit as described in Section 16.3(a).

Hinge the fascia assembly in the servicing position as described in Section 15.3(c).

Remove the burner assembly as described in Section 15.3(h).

Undo the two union nuts and the pipe to the expansion vessel, remove the pump from the pipe-work. Support the pump and remove the electrical cover.

Disconnect the electrical wires taking note of their positions.

Fit the replacement pump in the reverse order using new sealing washers.

(Alternatively replace the pump head only by removing the four Allen screws on the pump, remove the head and support whilst removing the electrical connections. Refit the new head).

Open the valves and fill and re-pressurise the system as described in Section 13.2

**Note:** The direction of flow should be upwards. The speed should always be set to maximum.

**15. Expansion Vessel.**

Drain the central heating circuit as described in Section 16.3(a).

Isolate the gas supply at the mains.

Then either fit a separate expansion vessel on the central heating return to the appliance or replace the existing vessel as described below.

Drain the domestic circuit as described in Section 16.3(b).

Disconnect the flue system at the boiler.

Disconnect the appliance pipework at the appliance entry points ensuring precautions are taken to cope with any water remaining in the appliance.

Remove the appliance from the wall.

Disconnect the expansion vessel from the appliance by undoing the fitting nut at it's base.

Fit the replacement vessel in the reverse order.

Open the valves and fill and re-pressurise the system as described in Section 13.3

**16. Pressure Relief Valve.** See Fig. 41 and 42.

Drain the central heating circuit as described in Section 16.3(a).

Hinge down the fascia assembly as described in Section 15.3(c).

Remove the Bottom panel as described in Section 15.3(d).

Undo the discharge pipe connection and remove the valve retaining clip. Remove the valve taking care not to distort the pipework.

Fit the replacement valve in reverse order. Reconnect the discharge pipe.

Open the valves and fill and re-pressurise the system as described in Section 13.3.

**17. Water Flow Turbine.** See Fig. 41 and 43.

Check that the electricity supply to the appliance is turned off.

Drain the domestic hot water circuit as described in Section 16.3(b).

Remove the two upper screws and hinge down the fascia panel as described in Section 15.3(c).

Disconnect the electrical connection.

Unscrew the securing nuts and remove the turbine housing from the pipework.

Fit the replacement water flow turbine in the reverse order ensuring new fibre washers are fitted to the new turbine body.

Check that the correct, blue, flow restrictor is fitted.

**NOTE: Washers are different**

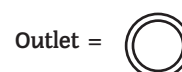
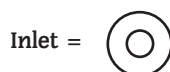

**Fig. 42. Pressure relief valve.**

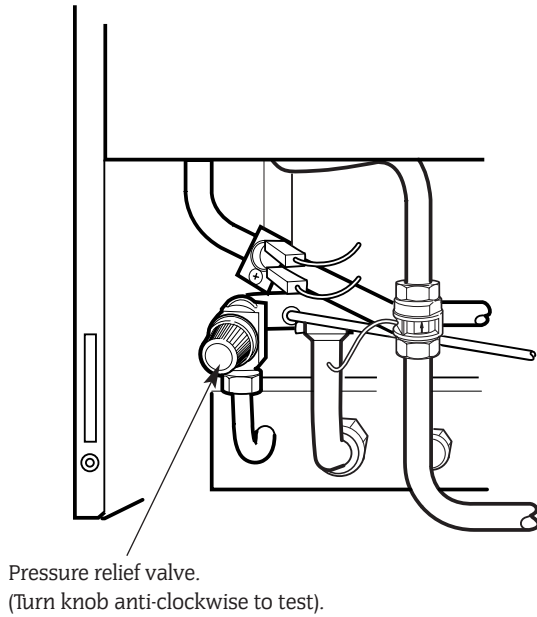

**Fig. 43. Water Flow turbine.**

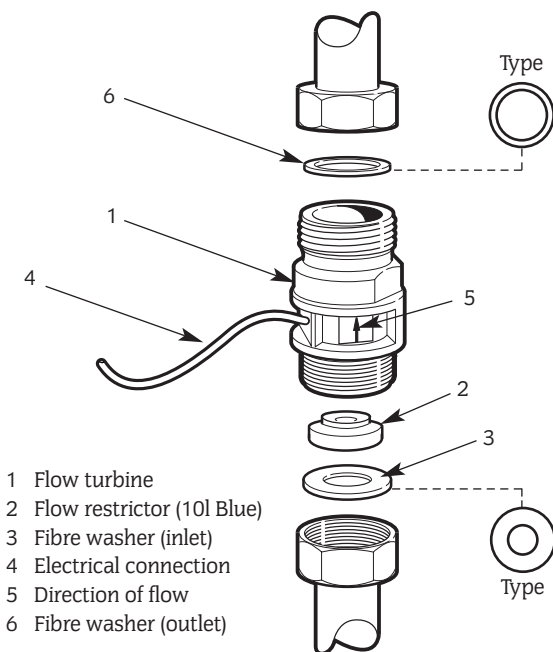

**19. Pressure Gauge.** See Fig. 34.

Check that the electricity supply to the appliance is turned off. Drain the central heating circuit as described in Section 16.3(a). Remove the two upper screws and hinge down the fascia panel as described in Section 15.3(c).

Prise back the retaining clips securing the gauge to the fascia panel. Unscrew the fixing disk and unplug the gauge from the pump inlet pipe.

Fit the replacement gauge in the reverse order ensuring the "O" ring is in place.

Open the valves and fill and re-pressurise the system as described in Section 13.3.

**20. Control Board.** See Fig. 44.

Check that the electricity supply to the appliance is turned off. Undo the 3 screws and remove the fascia bottom panel. Remove the two upper screws and hinge down the fascia assembly.

Carefully pull off all the connectors. Disconnect the mains supply lead at terminal X1 and unscrew the earth lead from the left and side panel.

Remove the four corner screws on the rear of the fascia and separate the metal back panel from the plastic fascia. Remove the flame sense and ignitor leads from the control board. Remove and retain the brass nut and washer. Release the six pillars on the control board and pull the control board forward off the back panel. Fit the replacement board in the reverse order ensuring it is pushed firmly onto the six pillars and clicks into place. Special care should be taken with the brass post and nut to ensure a good earth contact. (Check earth continuity between the incoming earth and the appliance chassis). Refit the fascia panel and hinge the control box assembly in the servicing position as described in Section 15.3 (c).

**Fig. 44. Control board.**

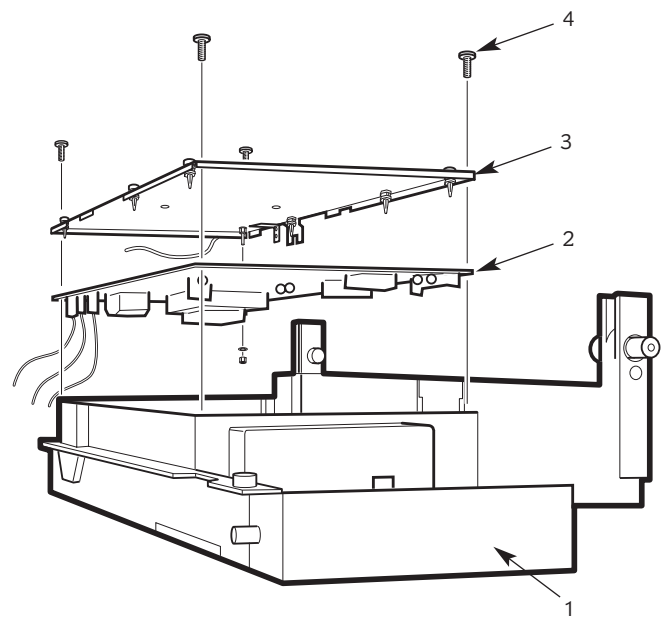

**21. Gauze Filter.** See Fig. 45.

Remove the water flow turbine as described in section 16.4-17. Undo the lower union nut on flow switch housing. Undo the nut on the isolating valve and remove the mains water inlet pipe. Carefully extract the filter from the valve end of the pipe. Replace the filter and refit the pipe in reverse order using a new fibre washer.

**Fig. 45. Gauze Filter.**

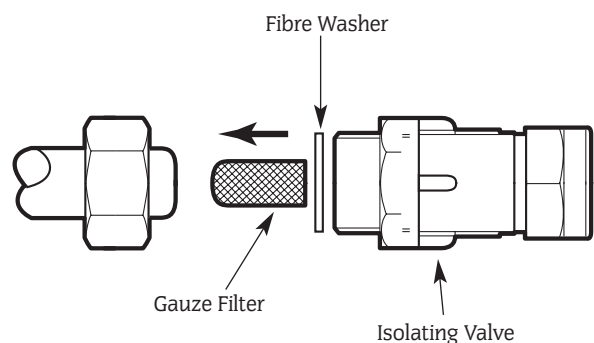

**22. Flue flow sensor.** See Fig. 46.

Check that the electricity supply to the appliance is turned off.

Remove the fan assembly as described in Section 15.3(e).

Unscrew the single central retaining screw and withdraw the sensor from the fan.

Fit the new sensor ensuring the correct orientation and carefully tighten the retaining screw.

Refit the fan assembly in reverse order.

**Fig. 46. Flue flow sensor.**

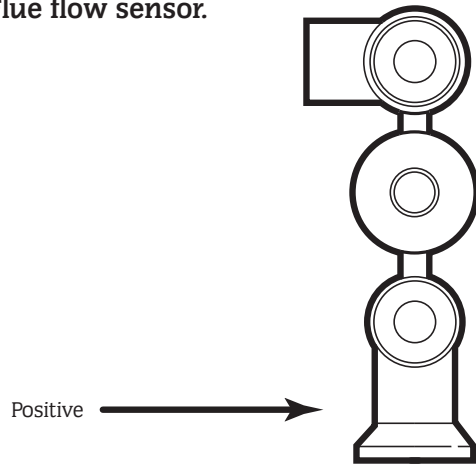

# 17. Operational Flow Diagrams

## 1. Central Heating Mode

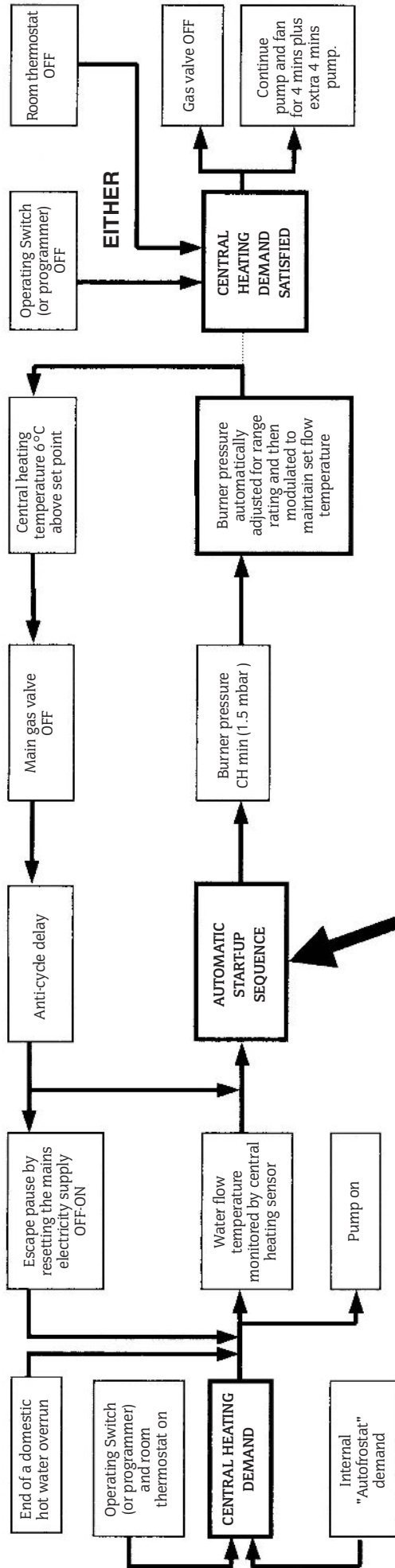

## AUTOMATIC START-UP SEQUENCE

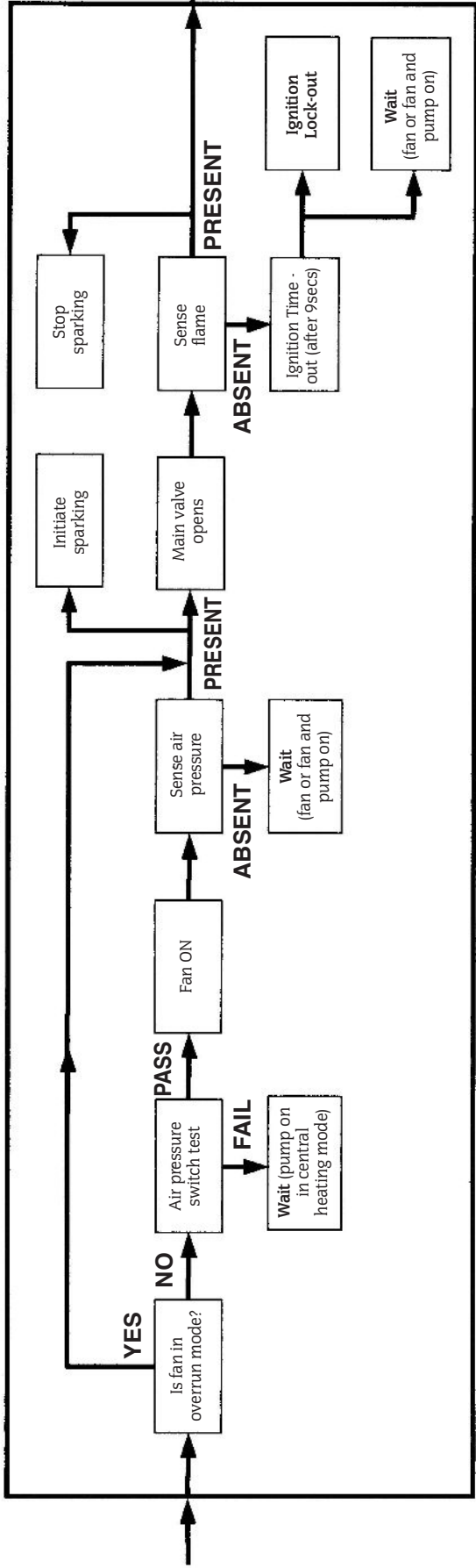

## 2. Domestic Hot Water Mode

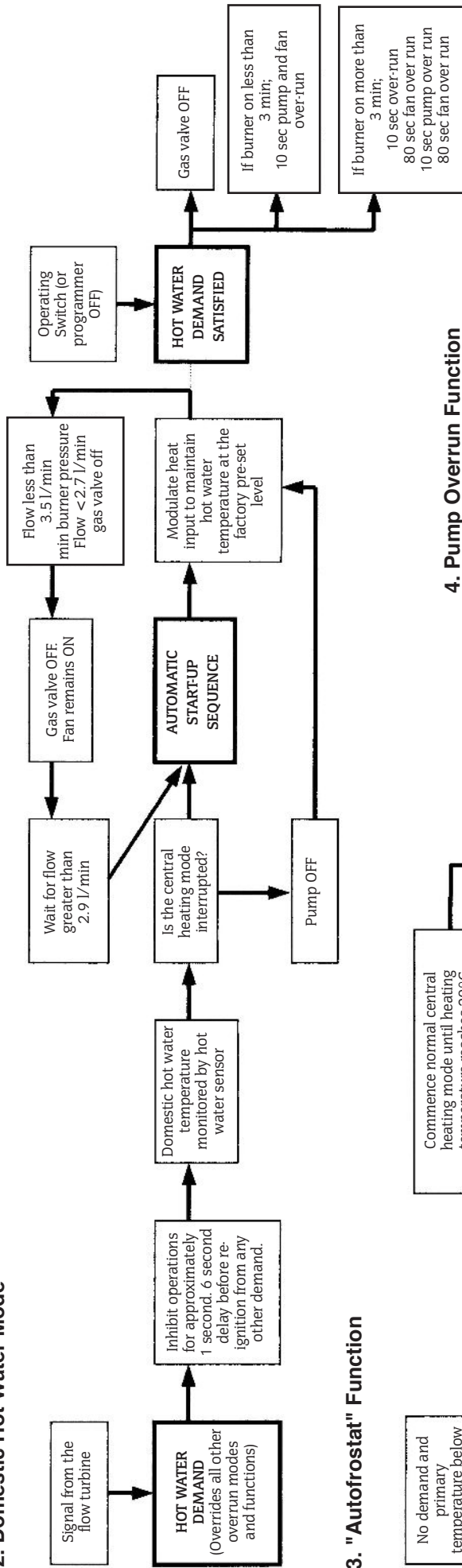

## 3. "Autofrost" Function

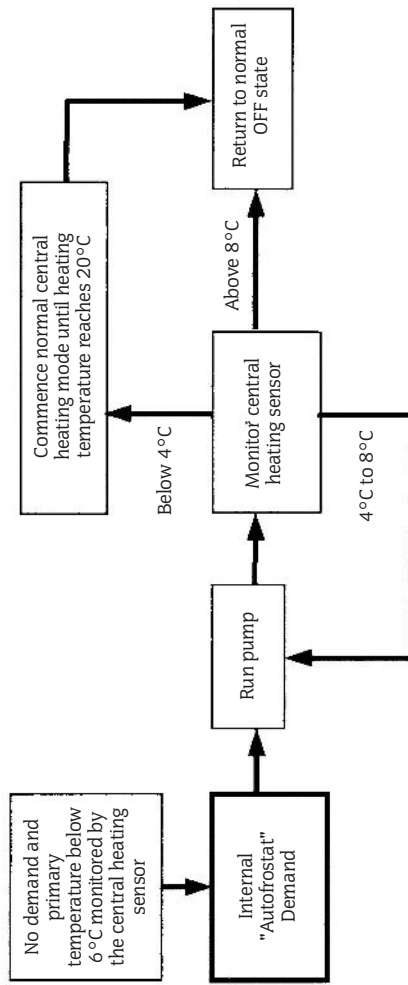

## 4. Pump Overrun Function



## 6. Central Heating ramp control

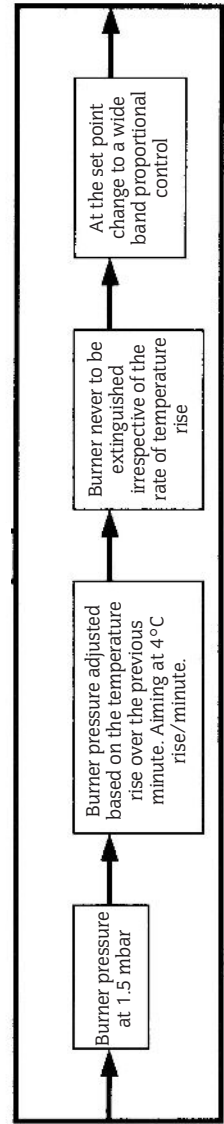

## 5. Over run Function

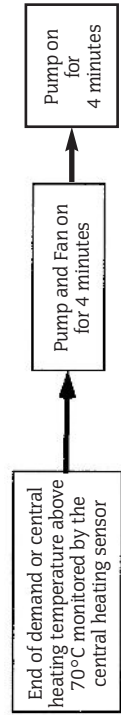

# 18. Fault Finding

**Note:** This fault-finding information is for guidance only. Worcester Heat Systems cannot be held responsible for costs incurred by persons not deemed to be competent.

## PRELIMINARY CHECKS

Preliminary electrical system checks are the first electrical checks to be carried out during a fault-finding procedure. On completion of the Service/Fault-Finding task which has required the breaking and remaking of electrical connections, check (a) EARTH CONTINUITY, (b) SHORT CIRCUIT CHECK, (c) POLARITY and (d) RESISTANCE TO EARTH.

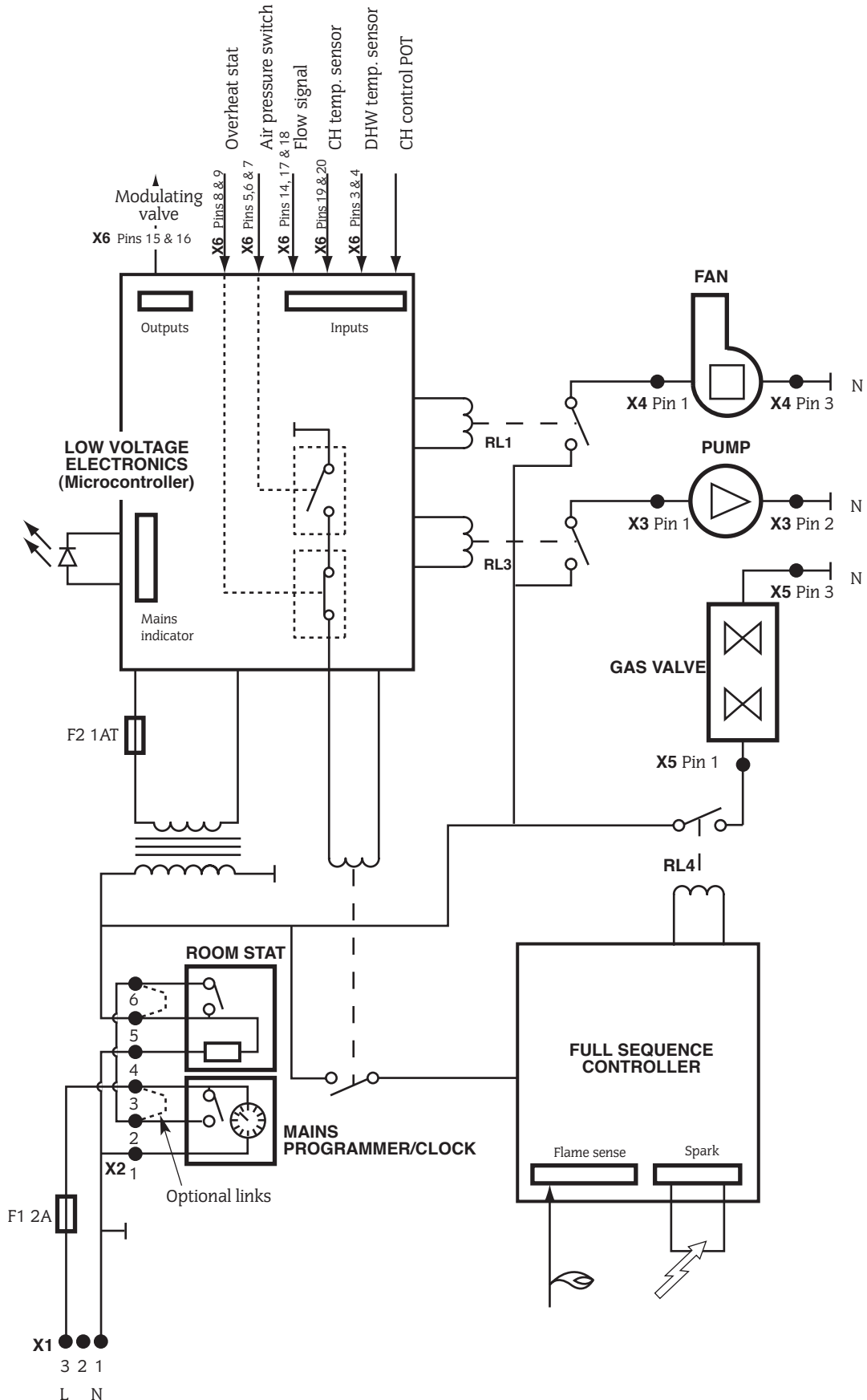

A

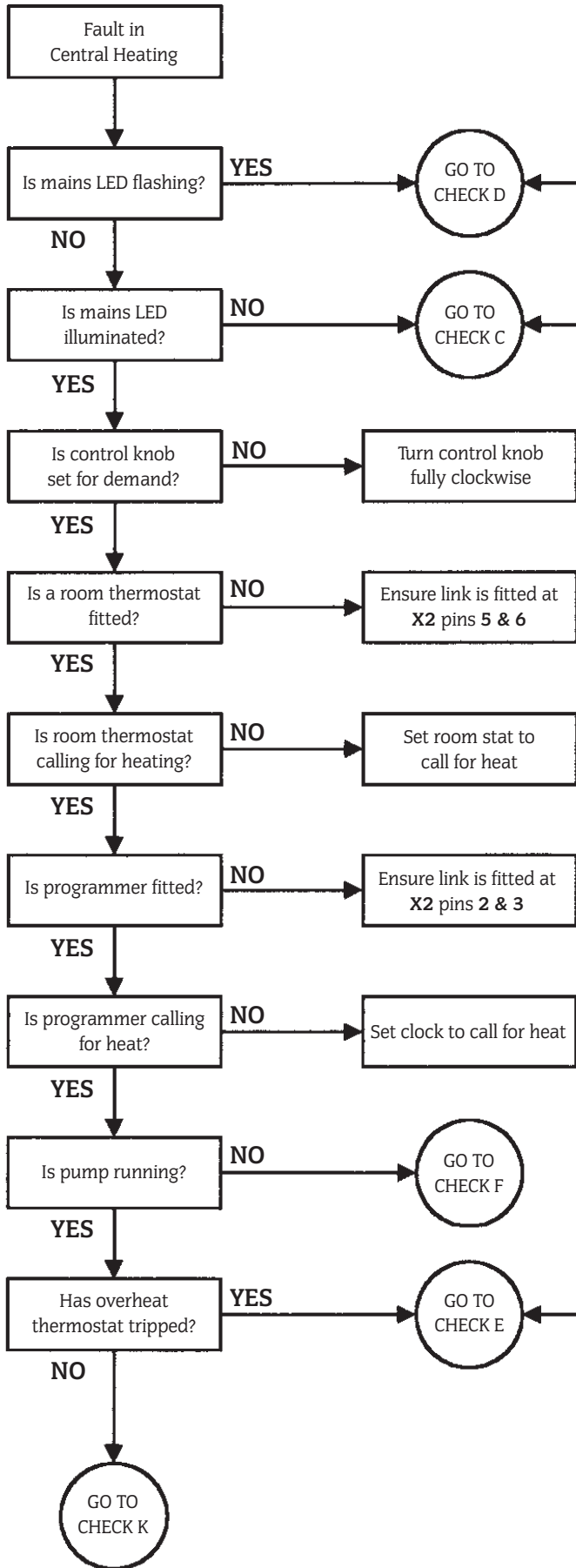

B

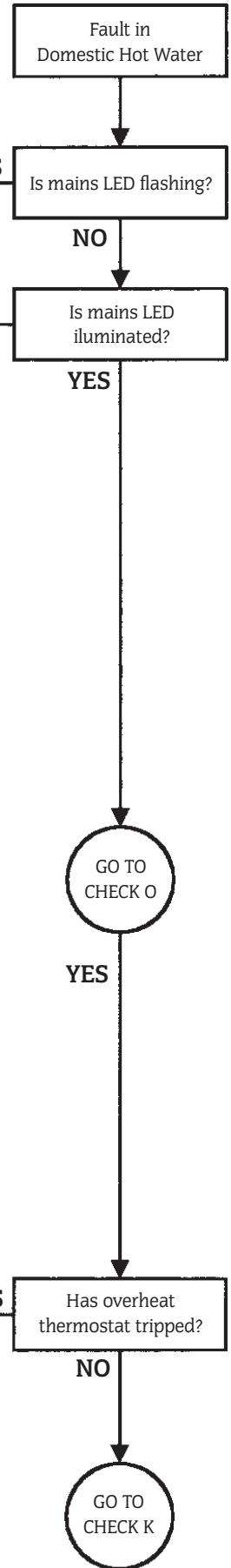

C

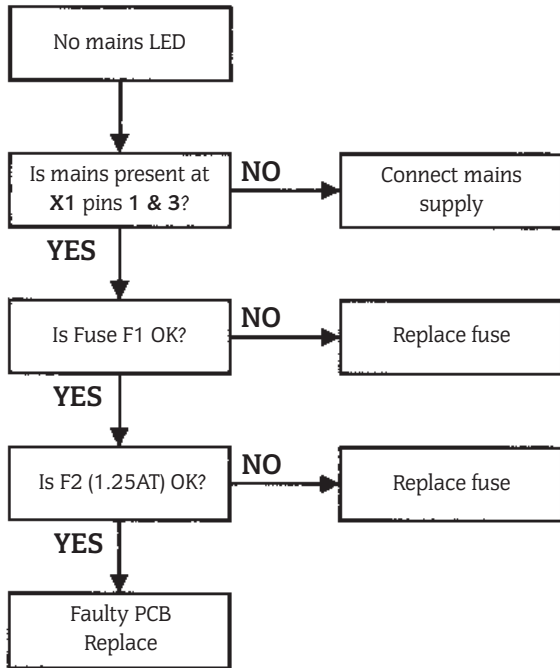

D

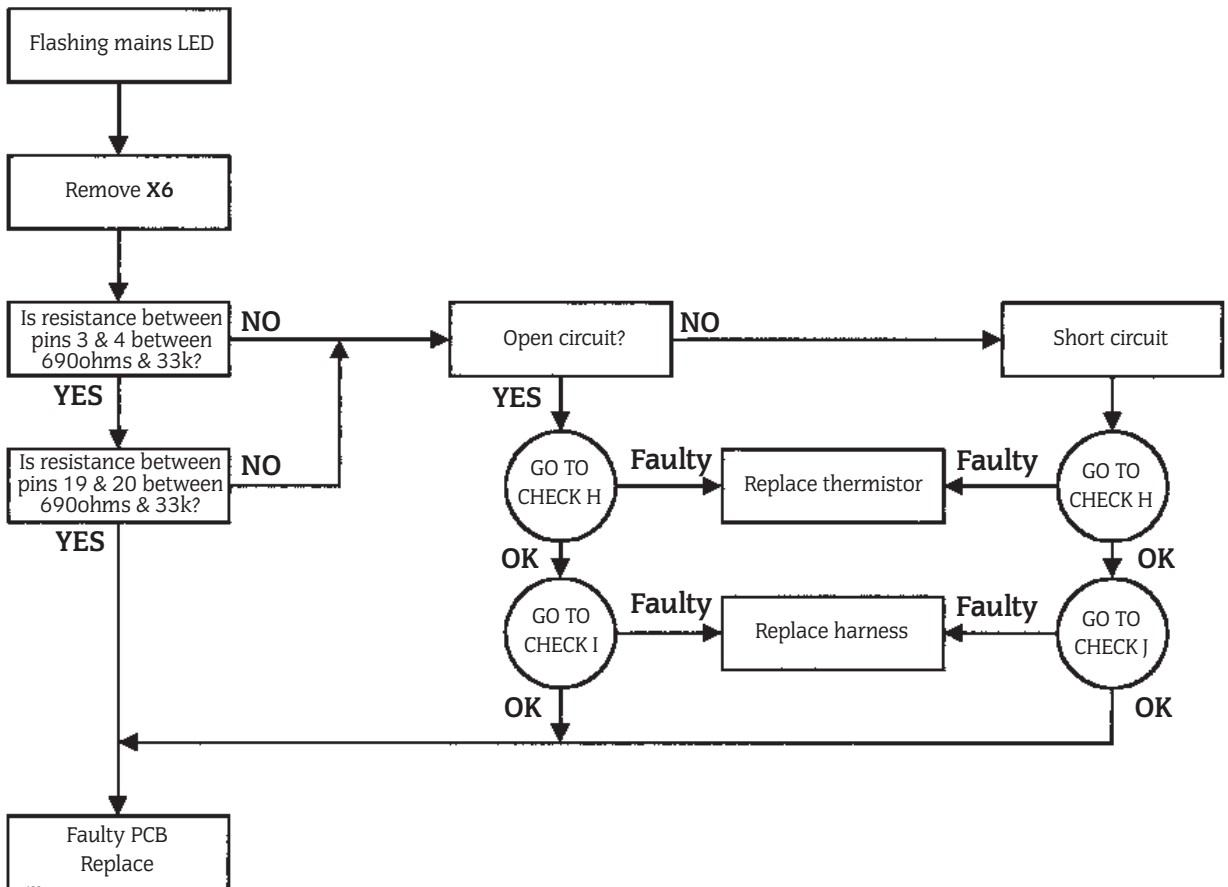

### Overheat Thermostat Check

E

The overheat thermostat can be reset by pressing the reset button, but if it trips immediately or on a regular basis a serious problem has occurred therefore contact your installer

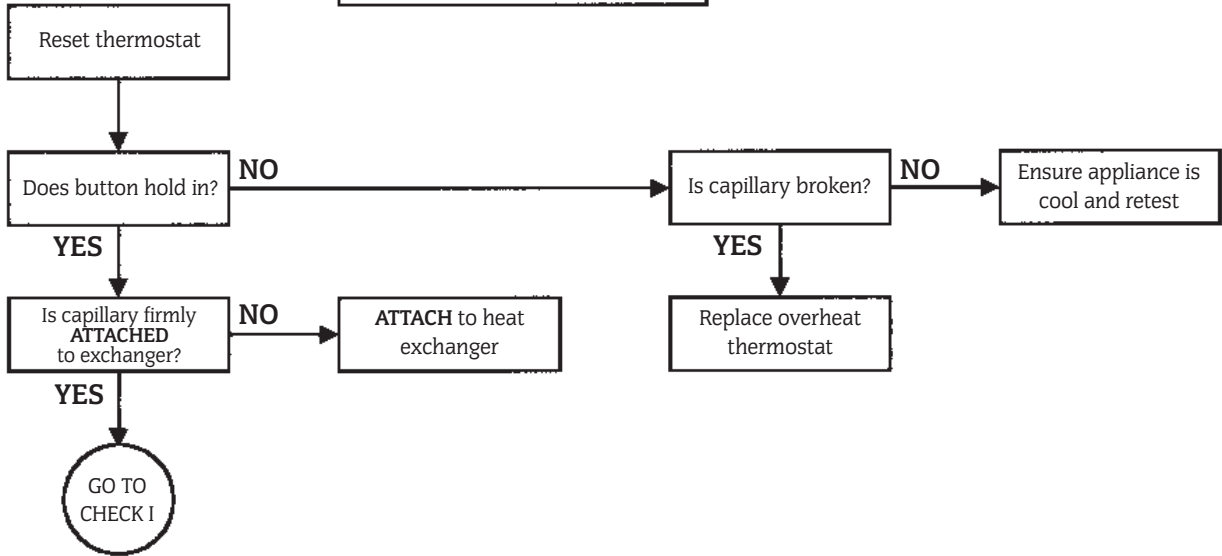

F

### Pump Check

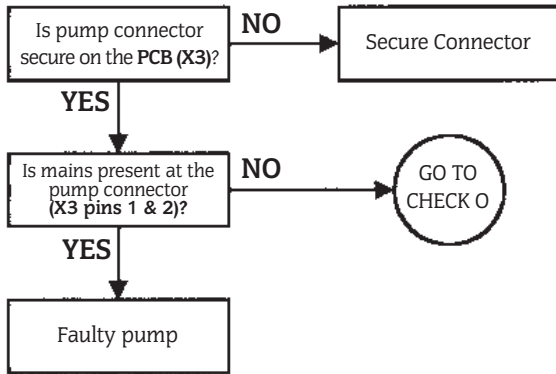

G

### Fan Check

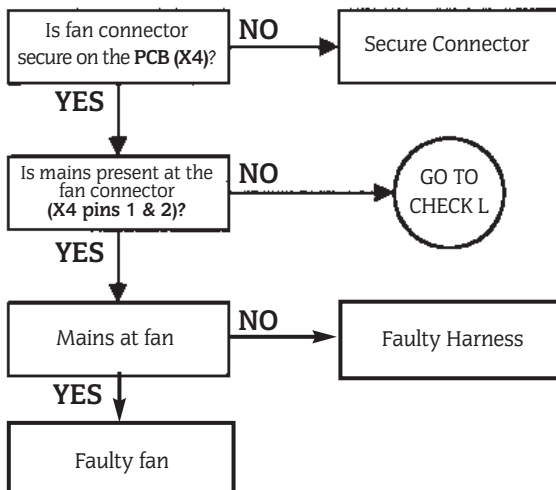

## H Thermistor Check

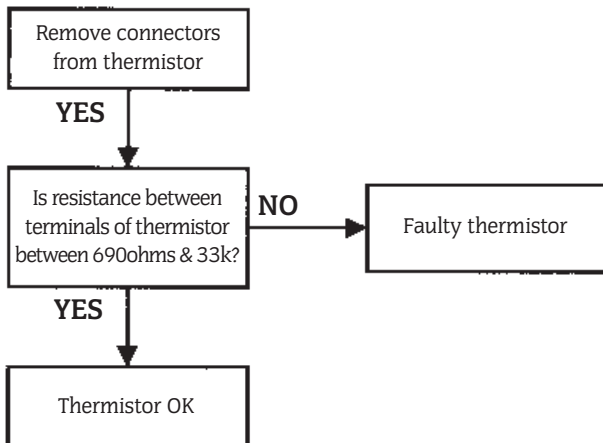

## I Harness Continuity Check

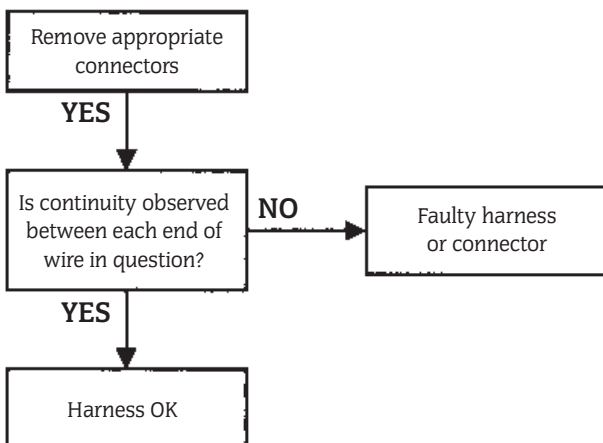

## J Harness Short Check

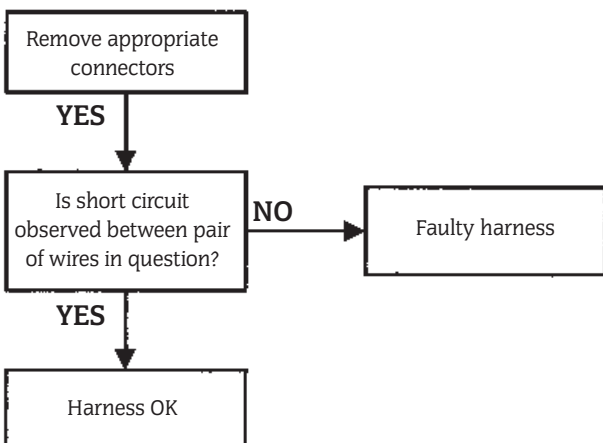

K

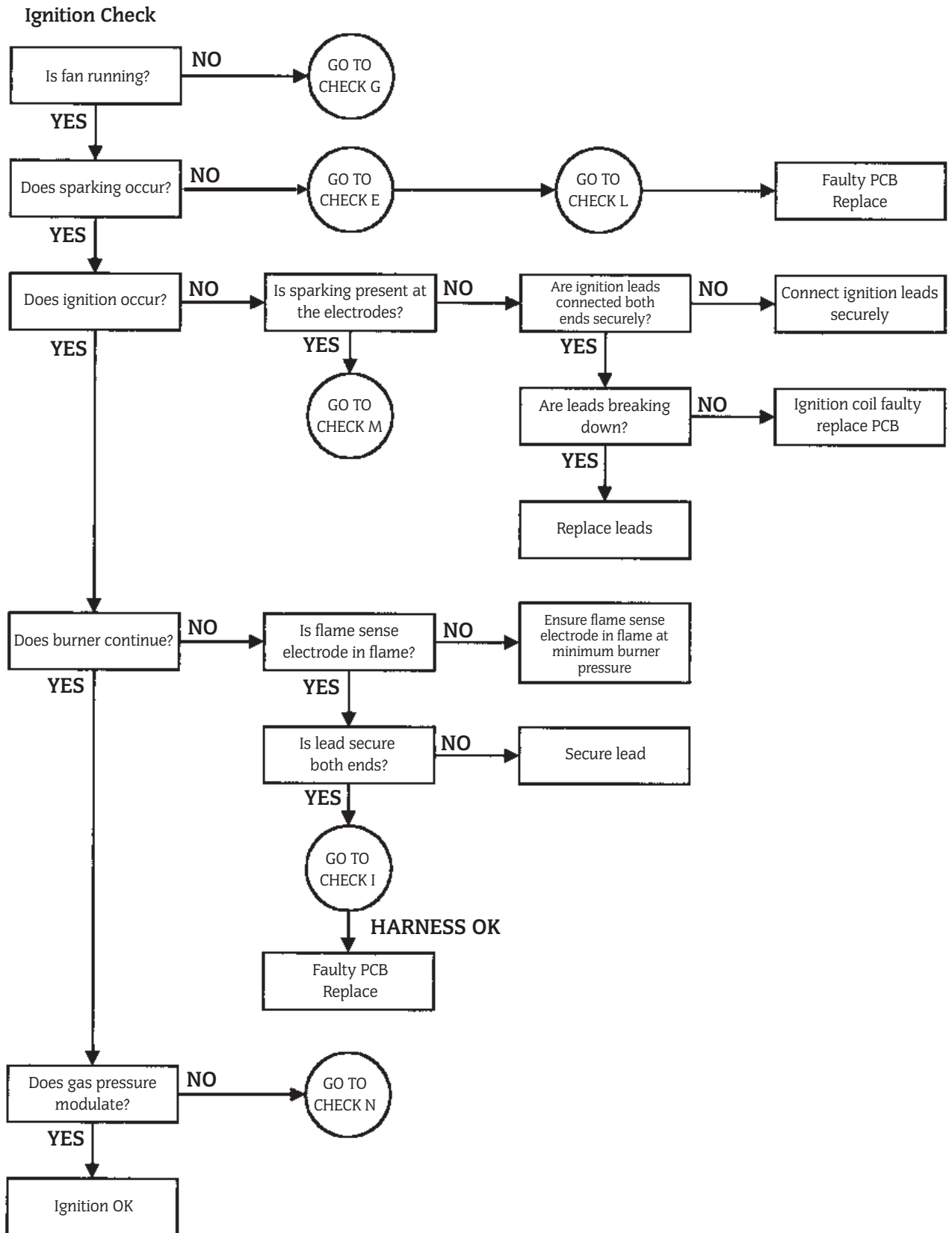

L

### Air Pressure Switch Check

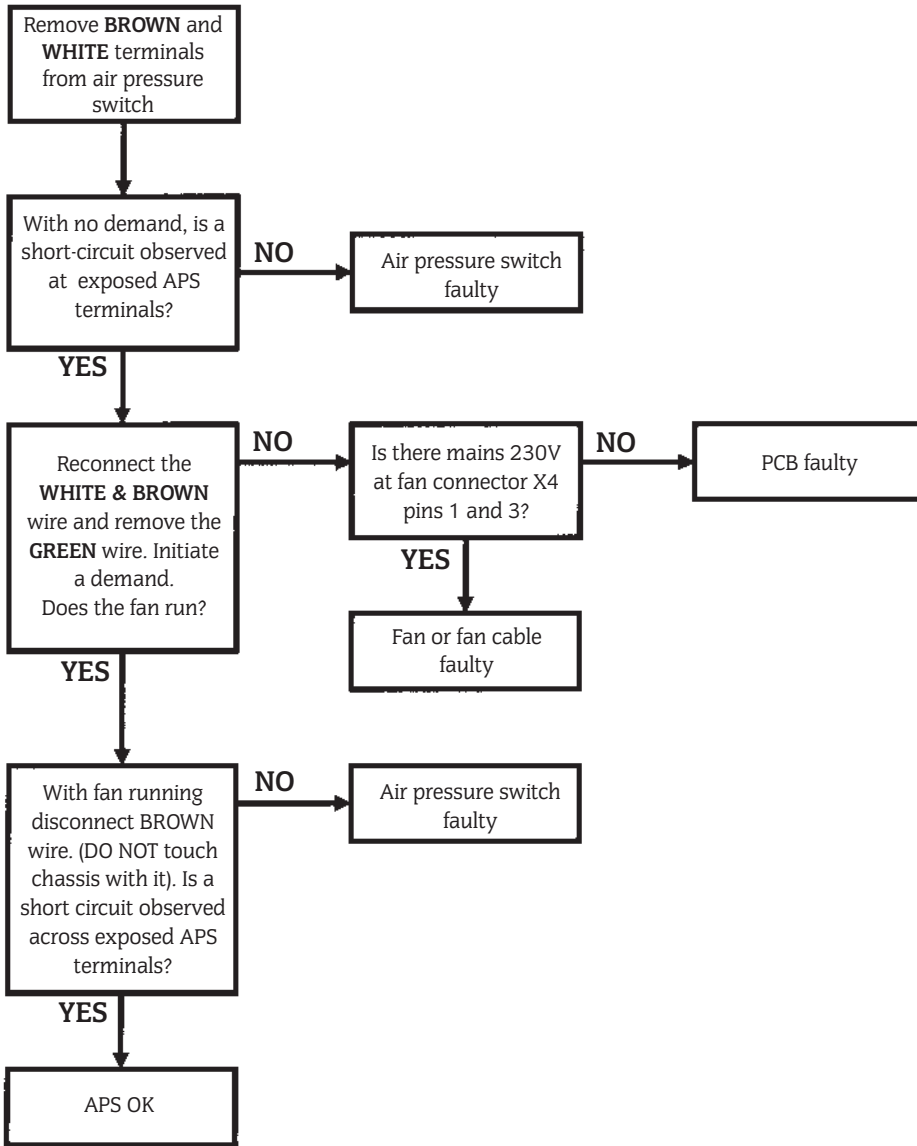

M

### Gas Valve Check

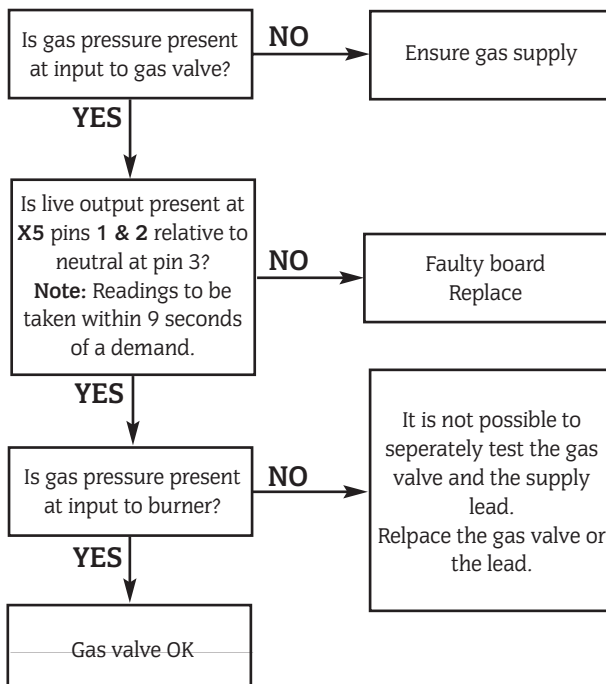

## N Modulating Valve Check

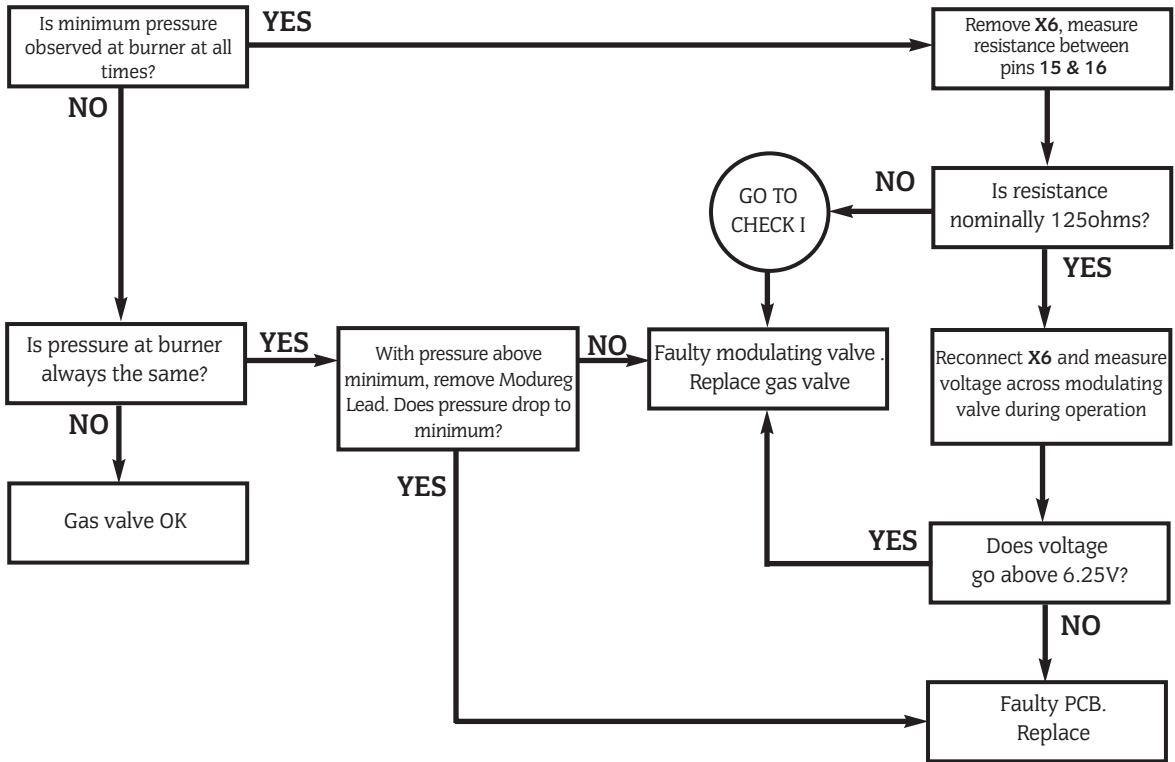

## O Flow turbine Check

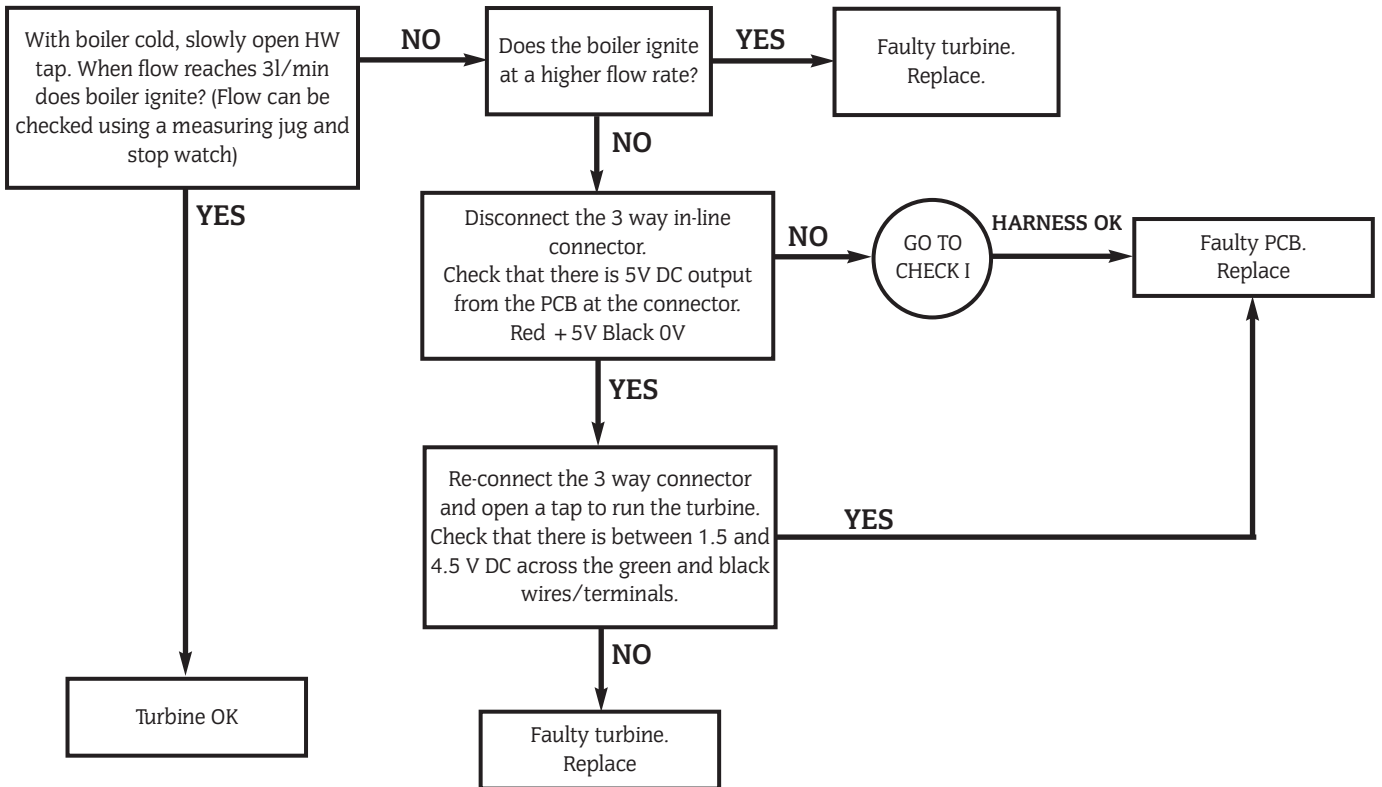

## 19. Component Parts List

Key No.	G.C. No.	Part	Manufacturer's Reference		Qty	WHS Part No.
1		Burner Assembly Natural Gas	Aeromatic	AC 23/053595	1	8 716 142 652 0
2		Injector Natural Gas	Stereomatic	Ø 4.5mm	1	8 716 140 208 0
3	E01-892	Gas valve Natural Gas	Dungs	BM771	1	8 716 150 766 0
4		Air Pressure Switch	Huba	605.99530	1	8 716 146 159 0
5	375-697	Spark Electrode Assembly	Bucclench		1	8 716 142 100 0
6	E01-612	Flame Sensor	Bucclench		1	8 716 120 345 0
	E01-930	Flame sensor Harness	Bucclench		1	8 716 120 126 0
7	E01-598	Ignition Harness	Bucclench		1	8 716 120 236 0
8	E01-599	Gas to Water Heat Exchanger	Giannoni		1	8 716 142 905 0
9	E01-600	Insulation Pack	WHS		1	8 716 192 216 0
10	E01-601	Auto Air Vent	Intermes		1	8 716 140 5040
11	299-506	Pressure Gauge	Cewal		1	8 716 142 300 0
12	375-699	Pressure Relief Valve	Caleffi	3141 3bar	1	8 716 142 404 0
13	E01-602	Pump with Harness	Grundfos	15 60 Special	1	8 716 143 107 0
14	E01-603	Expansion Vessel	Winkelman Panhof	(8Ltr) 389mm Dia	1	8 716 142 502 0
15	E58-079	PCB Boiler Control	Pactrol	423100	1	8 716 146 329 0
16	E04-582	Temperature Thermistors	Elmwood		2	8 716 142 384 0
	E01-900	CH Thermistor Clip			1	8 716 148 313 0
	299-495	DHW Thermistor Clip			1	8 716 148 303 0
18	E01-605	DHW Flow Regulator	Blue		1	8 716 141 052 0
19	324-822	Gauze Filter	WHS		1	8 716 148 401 0
20		Flow Turbine	SIKA VTY		1	8 716 146 160 0
21		Fan Assembly	FIME		1	8 716 121 681 0
22	E01-607	Overheat Thermostat	Ranco	LM7	1	8 716 142 307 0
23	299 357	Fuse Pack	WHS		1	7 716 192 206 0
24	E01-610	Gasket Pack	WHS		1	7 716 192 281 0
<b>ACCESSORIES</b>						
	299-360	Mechanical Programmer Kit	DIEHL			7 716 192 002
	E05-341	Mini Expansion Vessel Kit	Including new pipe and Expansion Vessel			7 716 192 188
<b>FLUE OPTIONS</b>						
		Telescopic Horizontal Flue Kit	425 - 725mm			7 716 191 068
	E01-943	Extension Flue Kit	750mm			7 716 191 006
	E01-944	Vertical Flue Kit				7 716 191 069
	E01-945	Vertical Flue Adaptor				7 716 191 016
	E01-946	Internal Fixing Kit	Telescopic Flue			7 716 191 019
	E01-058	Flue Elbow Kit	90 deg.			7 716 191 013
	E01-059	Flue Elbow Kit	45 deg.			7 716 191 014

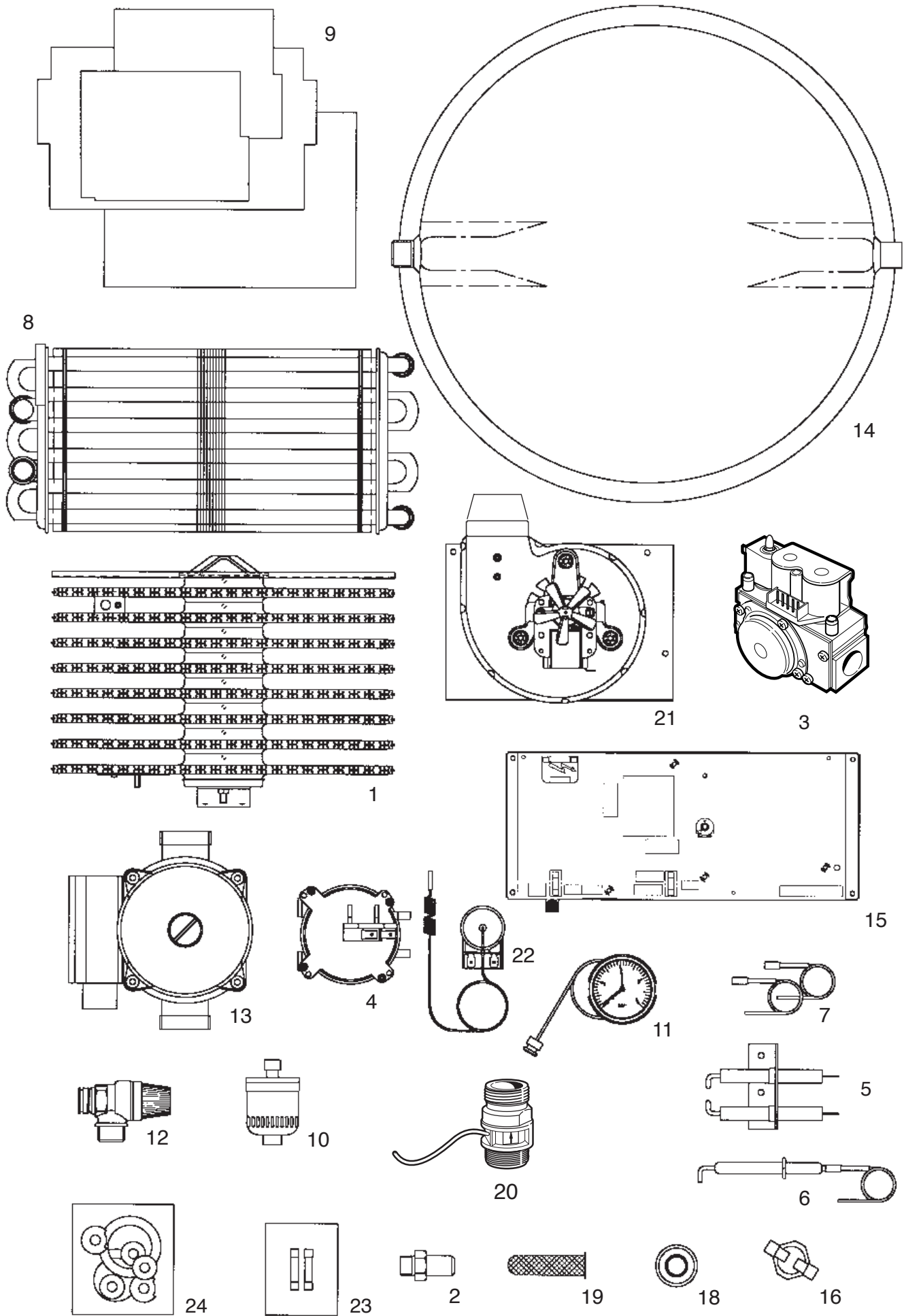



This manual is to be used in conjunction with the variant part number of the bar code below:



8716121684



Worcester Heat Systems Limited (Bosch Group), Cotswold Way, Warndon, Worcester WR4 9SW.

Telephone: (01905) 754624. Fax: (01905) 754619.

Technical Helpline (08705) 266241.

[www.worcester-bosch.co.uk](http://www.worcester-bosch.co.uk)

---

This booklet is accurate at the date of printing but will be superseded and should be disregarded if specifications and/or appearances are changed in the interests of continued improvement.

All goods sold are subject to our official Conditions of Sale, a copy of which may be obtained on application.

**PUBLICATION 8 716 114 751a (11/07)**