



WORCESTER

Bosch Thermotechnik

280 RSF

WALL MOUNTED COMBINATION BOILER FOR CENTRAL HEATING
AND MAINS FED DOMESTIC HOT WATER

INSTALLATION AND SERVICING INSTRUCTIONS



GC No. 47 311 11

BOILER OUTPUT

Automatic Modulating Control

To Domestic Hot Water

Minimum 10.5 kW (35,900 Btu/h)

Maximum 28.0 kW (95,500 Btu/h)

To Central Heating

Minimum 10.5 kW (35,900 Btu/h)

Maximum 24.0 kW (82,000 Btu/h)

IMPORTANT: THIS APPLIANCE IS FOR USE WITH **NATURAL GAS ONLY**

THESE INSTRUCTIONS APPLY IN THE UK ONLY

THESE INSTRUCTIONS ARE TO BE LEFT WITH THE USER OR AT THE GAS METER

Contents

1. Installation Regulations	Page 2
2. General Information	Page 2
3. Technical Data	Page 4
4. Siting the Appliance	Page 5
5a Siting the Flue Terminal.....	Page 5
5b. Flue Options.....	Page 5
5c. Vertical Flue System.....	Page 7
6. Air Supply	Page 7
7. Sealed System	Page 9

8. Open Vent Primary Systems.....	Page 10
9. Domestic Hot Water.....	Page 11
10. Electrical	Page 12
11. Installation.....	Page 15
12. Commissioning.....	Page 29
13. Instructions to the User.....	Page 32
14. Inspection and Servicing	Page 34
15. Replacement of Parts.....	Page 35
16. Operational Flow Diagrams.....	Page 44
17. Fault Finding.....	Page 46
18. Short Parts List.....	Page 52

1. Installation Regulations

1.1 Gas Safety (Installation and Use) Regulations 1984: All gas appliances must be installed by a competent person in accordance with the above regulations. Failure to install appliances correctly could lead to prosecution.

1.2 The manufacturers notes must not be taken, in any way, as overriding statutory obligations.

1.3 The compliance with a British Standard does not, of itself, confer immunity from legal obligations. In particular the installation of this appliance must be in accordance with the relevant requirements of the Gas Safety (Installation and Use) Regulations 1984 (as amended), current IEE Wiring Regulations, local Building Regulations, Building Standards (Scotland) (Consolidation), by-laws of the local Water Company and Health and Safety Document No. 635 (Electricity at Work Regulations 1989). It should be in accordance with the relevant recommendations of the following British Standards.

BS 6798:1987 Specification for installation of gas fired hot water boilers of rated input not exceeding 60kW

BS 5449:1990 Central Heating for Domestic Premises

BS 5546:1990 Installation of gas hot water supplies for domestic purposes

BS 5440:1:1990 Flues and ventilation for gas appliances of rated input not exceeding 60kW: Flues

BS 5440:2:1989 Flues and ventilation for gas appliances of rated input not exceeding 60kW: Air Supply

BS 6891:1988 Installation of low pressure gas pipework installations up to 28 mm (R1)

1.4 To ensure that the installation will perform to the highest standards, the system and components should conform to any other relevant British Standards in addition to those mentioned in the instructions.

2. General Information

2.1 This appliance is not suitable for external installation.

2.2 The appliance controls are set to provide a maximum output of 28 kW for the domestic hot water and a central heating load of up to 24 kW.

2.3 The control circuit provides automatic ignition. A permanent pilot is not used.

2.4 PRINCIPLE APPLIANCE COMPONENTS

A low thermal capacity Gas to Water heat exchanger.

A Water to Water heat exchanger to provide domestic hot water.

Fully modulating controls in the central heating and domestic hot water modes of operation.

An expansion vessel, pressure gauge and pressure relief valve.

A by-pass for the central heating system.

Temperature safety cut-out controls.

A water flow regulator.

A standard flue assembly including a 90° flue bend.

A flue kit for the internal fitting of the flue assembly.

Optional extra flue kits to provide for flue lengths up to a maximum of 3000 mm.

Optional extra 90° flue bends.

Note: The maximum flue length reduces when a flue bend (or bends) is fitted to the flue assembly.

An optional extra vertical balanced flue system.

An optional extra fascia mounted programmer.

2.5 ELECTRICAL SUPPLY.

Mains supply: 240V ~, 50Hz, 270 watts.

External fuse: 3A. Internal fuse: 3A Fast blow.

2.6 GAS SUPPLY.

The boiler requires 3.35 m³/h (115 ft³/hr) of natural gas with a calorific value of 38.7 MJ/m³ (1038 Btu/h). The gas meter and supply pipes must be capable of supplying this quantity of gas in addition to the demand from any other appliances being served.

The following table gives an indication of limiting gas pipe lengths and the allowance to be made for fittings. Refer to BS6891 for further information.

TOTAL LENGTH OF GAS SUPPLY PIPE (metres)			Pipe Diameter (mm)
3	6	9	
Gas Discharge Rate (m ³ /h)			
8.7	5.8	4.6	22
18.0	12.0	9.4	28

The gas meter governor should deliver a dynamic pressure of 20mbar (8in wg.) at the appliance, equivalent to a pressure of about 18.5–19 mbar at the gas valve.

The complete installation including the gas meter must be tested for soundness and purged. See BS 6891.

2.7 PACKING.

The appliance and flue components are packed in separate cartons.

2.8 GENERAL INSTALLATION.

The appliance is supplied for connection to a sealed system but is suitable for use with an open system.

The specified ventilation openings made into a wall or compartment door must not be obstructed.

If the appliance is to be fitted into a compartment, then the compartment must conform to the requirements of BS 6798: 1987: Section 6.

Do not place anything on top of the appliance.

The clearances specified for servicing must be maintained.

Fig. 1. Appliance water flow diagram.

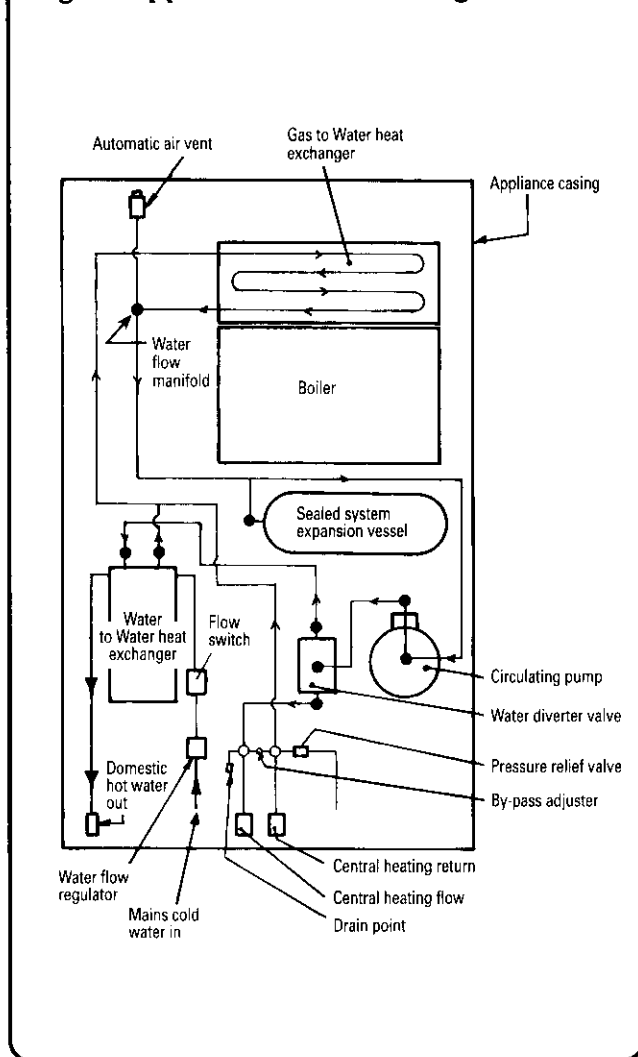

2.9 FLUE.

The appliance has a multi-directional balanced fanned flue system - right, left or rear.

A terminal guard, Type K2, GC 393 553, is available from Tower Flue Components, Vale Rise, Tonbridge, TN9 1TB.

The standard flue assembly length is from 100 mm to 1000 mm measured from the flue side of the appliance casing.

Extended flue lengths from 1000 mm to 3000 mm are available in 1000 mm lengths as optional extras.

A maximum of two 90° flue bends can be fitted in addition to the one supplied and are available as optional extras.

Note: When using an additional 90° flue bend (or bends) the maximum flue length is reduced. See Section 5b.

Do not allow the flue terminal (fitted to the outside wall) to become obstructed or damaged.

An optional extra internal flue fixing kit is available. When ordering the kit the following part number must be quoted: ZEGAS206. For fitting instructions refer to Section 11.6.

A vertical balanced flue is available with a flue height from 100 mm to 3500 mm.

2.10 CONTROLS.

The electronic control system (via the gas valve) modulates the heat input in response to the central heating and domestic hot water temperature settings between minimum and maximum.

The Operating Switch provides for the selection of domestic hot water only (**WATER**) or central heating and domestic hot water (**HEATING & WATER**) or **OFF**.

A fascia mounted programmer is available as an optional extra. A remote mounted programmer may be connected to the appliance.

The indicator lights on the fascia panel show the status of the appliance.

The electronic controls prevent rapid cycling of the appliance in the central heating mode.

There is provision for the connection of a mains voltage room thermostat and/or a frost thermostat

Frost Protection.

The appliance has a built-in device for frost protection. When the water in the boiler section drops to a temperature of about 8°C the appliance will operate. Under most operating conditions this will protect the appliance and system.

When parts of the heating system are likely to be exposed to exceptionally low temperatures, it is advised to fit a frost thermostat to protect the system.

2.11 SYSTEM NOTES.

Check that no dirt is left in either the gas or water pipework as this could cause damage to the appliance. The primary system should be flushed and treated in accordance with the recommendations of BS 7593: 1992. Purge the gas supply before finally connecting the appliance.

The water pipe connections throughout a sealed system must be capable of sustaining a pressure of up to 3 bar.

Radiator valves must conform to the requirements of BS2767 (10): 1972.

The pressure relief valve drain outlet must be directed away from any electrical components or where it would cause a hazard to the user.

A drain cock to BS 2879 must be fitted to the lowest point of the system.

For circuit design purposes it is important that due note is taken of the information given in Table 3 relating to the available pump head.

2.12 SHOWERS, BIDETS, TAPS AND MIXING VALVES.

Hot and cold taps and mixing valves used in the system must be suitable for operating at mains pressure.

Thermostatically controlled or pressure equalising shower valves will guard against the flow of water at too high a temperature.

Hot and cold mains fed water can be supplied direct to an over-rim flushing bidet subject to local Water Company requirements.

With all mains fed systems, the flow of water from the individual taps will vary with the number of outlets operated simultaneously and the cold water mains supply pressure to the property. Flow balancing using 'Ball-o-Fix' type valves is recommended to avoid an excessive reduction in flow to individual outlets. For further information contact Worcester Heat Systems Ltd.

2.13 SAFETY CONSIDERATIONS.

The appliance must not be operated in a waterless condition.

The appliance must not be operated with the boiler inner casing panel removed.

Work must not be carried out on the appliance without the gas and electricity supplies being turned off.

Checks must be made to ensure that the ventilation openings made into walls and partitions are of the correct size and are not obstructed.

2.14 OPERATION.

See Fig. 1.

Domestic Hot Water Mode: With a demand for hot water the burner will light at its maximum setting and then automatically adjust its output to maintain the temperature rise of the delivered water. When domestic hot water is no longer required the burner goes out. After a delay of a few seconds the pump will continue to run for a short period to dissipate the residual heat from the appliance around the central heating circuit.

Note: If it is required to use the appliance for domestic hot water before the central heating is connected, a 22 mm copper by-pass pipe must be connected between the central heating flow and return. The minimum length of the by-pass pipe should be 2 meters. Fill the appliance via a sealed system filling loop or a header tank. See Figs. 7 or 8.

Central Heating Mode: With a demand for heating the burner will light at its minimum setting and gradually increase to the output required for the system. The output of the appliance is then automatically adjusted to maintain the temperature of the system as set by the Temperature Control Knob on the fascia. The output can reduce down to a minimum of 10.5 kW.

If the system no longer requires even the minimum output to

maintain the desired room temperature, the burner will extinguish. The pump will continue to run for a short period to dissipate the residual heat from the appliance. The appliance will remain off for a fixed period of about 2 minutes before re-lighting and running through the normal central heating mode of operation.

Domestic Hot Water and Central Heating Mode: The appliance will supply heat to the central heating system as required. A demand for hot water at a tap or shower will override the central heating function for the period of the domestic hot water demand. When domestic hot water is no longer required, the burner will extinguish for a few seconds before returning to the central heating state and its normal mode of operation.

3. Technical Data

See Figs. 2 and 3.

The data plate is fixed to the top of the control box casing.

TABLE 1

NOMINAL BOILER RATINGS							
Output		Input		Burner Setting Pressure		Gas Rate	
kW	Btu/h	kW	Btu/h	m bar.	in. wg.	m ³ /h	ft ³ /h
10.5 Min.CH	35,900 Min.CH	14.8	50,500	2.0	0.8	1.38	48.6
24.0 Max.CH	82,000 Max.CH	30.8	105,000	10.5	4.2	2.87	101.0
28.0 Max.DHW	95,500 Max.DHW	35.0	119,400	14.0	5.6	3.25	115.0

TABLE 3

AVAILABLE PUMP HEAD						
Boiler Output		Head		Min. Flow Rate		Temp. rise across heating flow and return
kW	Btu/h	metres	feet	litres/min	gal/min	
10.5	35,900	4.0	13.2	14.3	3.2	11°C (20°F)
15.0	50,000	2.3	7.5	21.0	4.63	
17.5	60,000	2.5	8.25	18.5	4.1	16°C (24°F)
24.0	82,000	2.0	6.6	19.5	4.3	21°C (38°F)

TABLE 4

SPECIFICATIONS	
CENTRAL HEATING FLOW FITTING	22 mm Compression
CENTRAL HEATING RETURN FITTING	22 mm Compression
COLD WATER MAINS INLET FITTING	15 mm Compression
DOMESTIC HOT WATER OUTLET FITTING	15 mm Compression
GAS INLET FITTING	Rc ³ / ₄
PRESSURE RELIEF VALVE DISCHARGE FITTING	15 mm Compression
OVERALL HEIGHT (including flue bend)	1075 mm (42.3 in.)
CASING HEIGHT	900 mm (35.4 in.)
CASING WIDTH	500 mm (19.7 in.)
CASING DEPTH	320 mm (12.6 in.)
DRY WEIGHT	59.6 kg (131 lb.)
MAXIMUM INSTALLATION WEIGHT	58.5 kg (129 lb.)
PACKAGED WEIGHT	61.0 kg (135 lb.)

TABLE 2 – Multi-directional Flue System

* Optional Extra

Horizontal Flue (Side or Rear)	mm	inches
Wall Hole Diameter	120	4.5
Wall Hole Diameter (* using internal fitting kit)	150	6.0
Standard Flue – Minimum Length	100	4
Standard Flue – Maximum Length	1000	39.3
Extended Flue – Maximum Length	3000	117

Note 1 The standard flue assembly includes one 90° bend.

Note 2 Optional extra flue bends are available. The maximum flue length is reduced when an extra flue bend (or bends) is used. Refer to notes 3 and 4.

Note 3 When using two flue bends (including the one supplied with the standard flue kit) the maximum extended straight flue length must not exceed 2300 mm.

Note 4 When using three flue bends (including the one supplied with the standard flue kit) the maximum extended straight flue length must not exceed 1000 mm.

Note 5 See Section 5b–Flue Options for further information.

Note 6 No more than three bends may be used.

TABLE 2a

Vertical Balanced Flue	mm	inches
Ceiling Hole Diameter	130	5.25
Minimum Air Duct Height	100	4.0
Maximum Air Duct Height	3500	138

Note: The maximum overall height of the vertical balanced flue measured from the top of the flue spigot on the appliance casing to the underside of the air inlet flange on the flue terminal is 4600 mm.

TABLE 5

SPECIFICATIONS	
PRIMARY WATER CAPACITY	3 litres (0.66 galls.)
MAXIMUM COLD SUPPLY PRESSURE	10 Bar (150 psi)
MINIMUM COLD SUPPLY PRESSURE (WORKING) FOR MAXIMUM HOT WATER FLOW	1.0 Bar (15.0 psi)
MINIMUM COLD SUPPLY PRESSURE (WORKING) TO OPERATE THE APPLIANCE	0.5 Bar (7.5 psi)
MAXIMUM CENTRAL HEATING FLOW TEMPERATURE	Nominally 82°C (180°F)
MAXIMUM STATIC HEAD (PRIMARY)	30 metres (97 ft)
MINIMUM STATIC HEAD (PRIMARY)	0.3 metres (1 ft)
OUTPUT TO DOMESTIC HOT WATER	Modulating 10.5–28.0 kW (35,900–95,000 Btu/h)
OUTPUT TO CENTRAL HEATING	Modulating 10.5–24.0 kW (35,900–82,000 Btu/h)
MAXIMUM DOMESTIC HOT WATER FLOW RATE FROM THE APPLIANCE	Nominally 10.0 litres/min (± 15%) (2.2 gallons/min)
EQUIVALENT DOMESTIC HOT WATER FLOW RATE TO GIVE A TEMPERATURE RISE OF 35°C	Nominally 11.4 litres/min (± 15%) (2.5 gallons/min)

4. Siting the Appliance

4.1 The appliance may be installed in any room although particular attention is drawn to the requirements of the current I.E.E. wiring regulations and, in Scotland, the electrical provisions of the building regulations applicable in Scotland, with respect to the installation of appliances containing baths or showers.

Where a room sealed appliance is installed in a room containing a bath or shower, any electrical switch or appliance control using mains electricity must not be able to be touched by a person using the bath or shower.

4.2 The appliance is not suitable for external installation.

4.3 The appliance does not require any special wall protection.

4.4 The wall must be capable of supporting the weight of the appliance. See Table 4.

4.5 If the appliance is to be fitted in a timber framed building refer to the British Gas publication " Guide for Gas Installations in Timber Framed Housing ".

4.6 The following clearances must be available for installation and for servicing. See Fig 2.

	Installation	Servicing
Above the flue bend	25 mm	25 mm
In front	600 mm	600 mm
Below	200 mm	200 mm
Right hand side	5 mm	5 mm
Left hand side	5 mm	5 mm

4.7 The appliance can be installed in a cupboard to be used for airing clothes provided that the requirements of BS 6798 and BS 5440:2 are strictly followed.

4.8 The airing space must be separated from the boiler space by a perforated non-combustible partition. Expanded metal or rigid wire mesh are acceptable provided that the major dimension is less than 13 mm. See BS 6798:1987.

4.9 No combustible surface must be within 75 mm of the appliance casing. See BS476:4.

4.10 The distance between the inner face of a cupboard door and the cabinet front should not be less than 75 mm.

4.11 Always consider the possible need to disconnect the pipes from the appliance after installation.

4.12 The appliance has a vertical flue option. See Section 5c.

5a. Siting the Flue Terminal

See Fig. 4.

5a.1 The flue must be installed as specified by BS 5440:Part 1.

5a.2 The terminal must not cause an obstruction nor the discharge a nuisance.

5a.3 If the terminal is fitted within 850 mm of a plastic or painted gutter or within 450 mm of painted eaves then an aluminium shield at least 750 mm long should be fitted to the underside of the gutter or painted surface.

5a.4 If a terminal is fitted less than 2 meters above a surface to which people have access, then a guard must be fitted. See Section 2.9.

5a.5 The terminal guard must be evenly spaced about the flue terminal and fixed to the wall using plated screws

5a.6 In certain weather conditions a terminal may steam and siting where this could cause a nuisance should be avoided.

5a.7 Take care to ensure that combustion products do not enter ventilated roof voids.

5b. Flue Options

5b.1 STANDARD HORIZONTAL FLUE. (Flue Option 1)

See Fig. 5. Frame 1.

The appliance is supplied with a standard horizontal flue assembly including one 90° flue bend. The standard flue length measured from the side of the appliance casing is from 100 mm to 1000 mm.

The flue may be positioned in any horizontal direction to suit the installation.

Notes:

(a) The following items referred to in this section are supplied as optional extras. The site must be surveyed and the items made available before the installation is commenced. When ordering extras the relevant part numbers must be quoted.

Fig. 2. Appliance casing dimensions and required clearances.

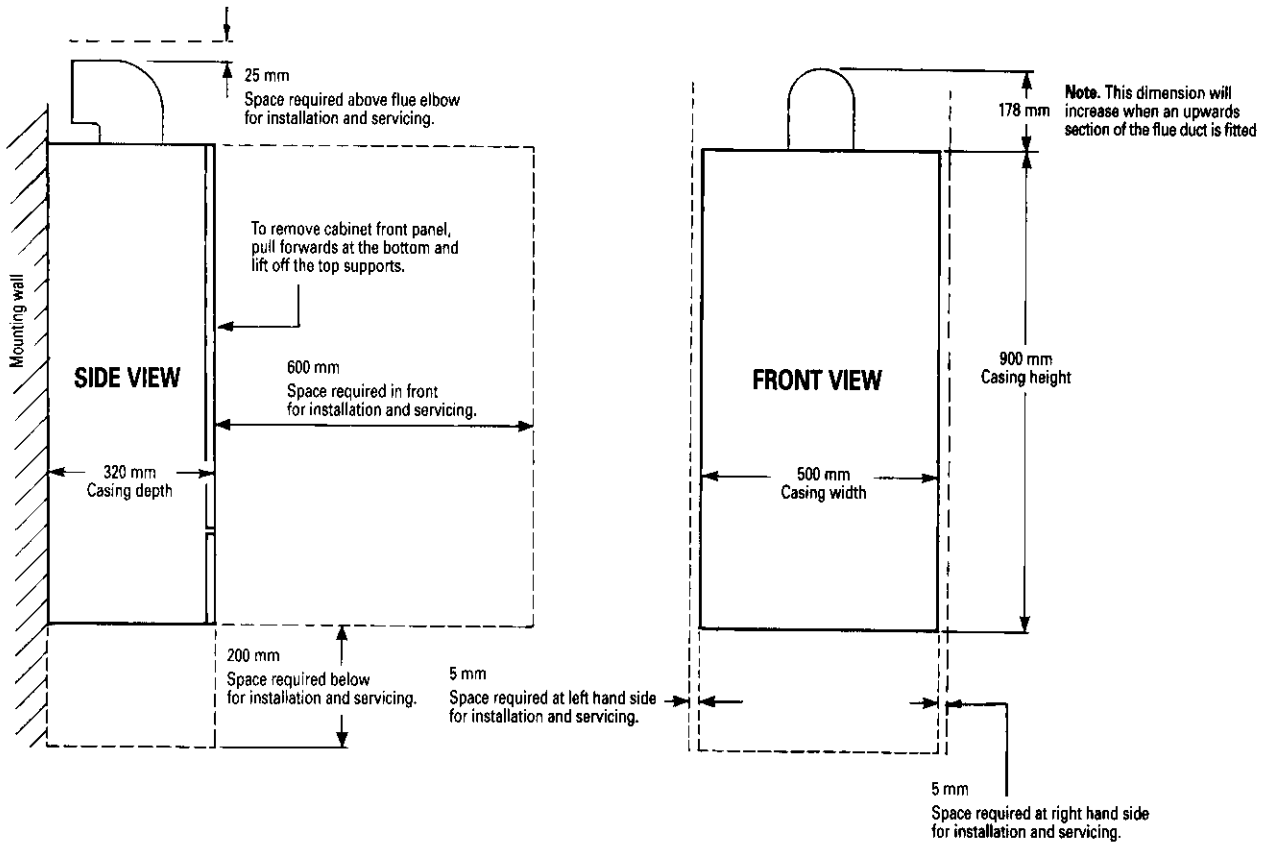

Fig. 3. Appliance pipework connections.

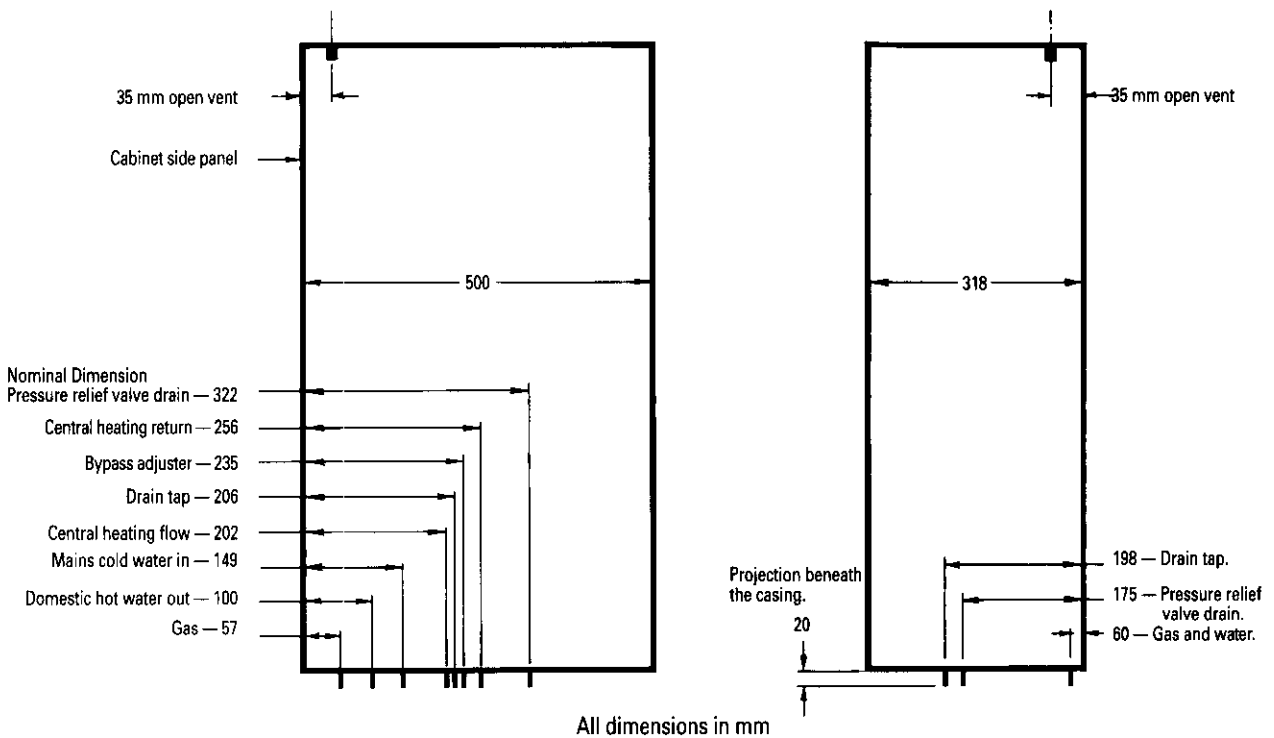
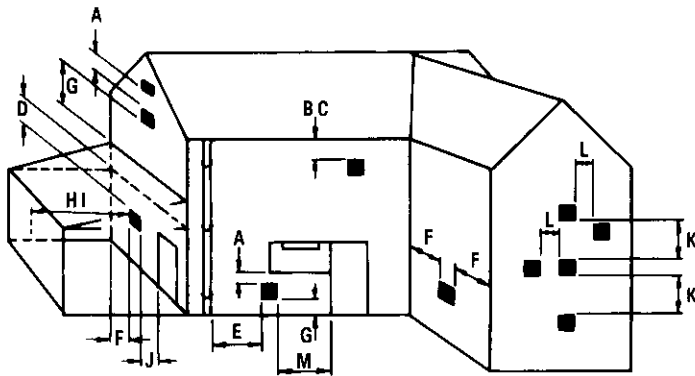

Fig. 4. Siting of the flue terminal.

MINIMUM SITING DIMENSIONS FOR POSITIONING THE BALANCED FLUE TERMINAL



TERMINAL POSITION	MIN. DISTANCE
A- directly below an openable window or other opening e.g. air brick.	300 mm (12 in.)
B- Below gutters, soil pipes or drain pipes.	75 mm (3 in.)
C- Below eaves.	25 mm (1 in.)
D- Below balconies or car port roof.	25 mm (1 in.)
E- From vertical drain pipes and soil pipes.	25 mm (1 in.)
F- From internal or external corners.	25 mm (1 in.)
G- Above ground, roof or balcony level.	300 mm (12 in.)
H- From a surface facing a terminal.	600 mm (24 in.)
I- From a terminal facing a terminal	1200 mm (47 in.)
J- From an opening in a car port (e.g. door window) into dwelling.	1200 mm (47 in.)
K- Vertically from a terminal on the same wall.	150 mm (6 in.)
L- Horizontally from a terminal on the same wall.	300 mm (12 in.)
M- From door, window or air vent (achieve where possible).	150 mm (6 in.)

Optional Extra	Part No.
Extension Flue Kit-1000 mm long	ZAGAS177
Flue Adaptor	ZAGAS179
90° Flue Bend	ZAGAS178
Flue Spacer	ZAGAS174
Air Duct Support Bracket	ZAGAS180
Flue Kit for Internal Fitting	ZEGAS206

(b) When determining the flue length required, always measure to the outside of the wall where the flue terminal will be fixed. See Fig.5.

(c) When measuring between the centre lines of flue ducts, allow 83 mm for each flue bend. See Fig.5.

5b.2 EXTENSION FLUE HORIZONTAL. (Flue Option 2)
See Fig.5. Frame 2.

Extension flue lengths may be added horizontally. The flue must be assembled from the standard flue supplied and the extension flue kits. The flue may be any length providing it does not exceed 3000 mm measured from the side of the appliance casing.

The flue assembly may be positioned in any horizontal direction to suit the installation.

5b.3 EXTENSION FLUE UPWARDS AND HORIZONTAL.
(Flue Option 3). See Fig.5. Frame 3.

Extension flue lengths may be added upwards and horizontally. The flue must be assembled from the standard flue supplied, the extension flue kits and a flue adaptor. The flue may be any length providing the total straight length does not exceed 3000 mm.

The horizontal section of flue may be positioned in any horizontal direction to suit the installation.

5b.4 EXTENSION FLUE HORIZONTAL USING A SECOND 90° FLUE BEND. (Flue Option 4). See Fig.5. Frame 4.

Extension flue lengths may be added horizontally and include a second 90° flue bend. The flue must be assembled from the standard flue supplied, extension flue kits and a second 90° flue bend. The flue may be any length providing the total straight length does not exceed 2300 mm.

The flue assembly including the second 90° flue bend may be positioned in any horizontal direction to suit the installation.

5b.5 EXTENSION FLUE UPWARDS AND HORIZONTAL USING A SECOND 90° FLUE BEND. (Flue Option 5).
See Fig.5. Frame 5.

Extension flue lengths may be added upwards and horizontally and include a second 90° flue bend. The flue must be assembled from the standard flue supplied, extension flue kits and a flue adaptor. The flue may be any length providing the total straight length does not exceed 2300 mm.

The horizontal section of flue and second 90° flue bend may be positioned in any horizontal direction to suit the installation.

5b.6 EXTENSION FLUE HORIZONTAL USING A THIRD 90° FLUE BEND. (Flue Option 6). See Fig.5. Frame 6.

Extension flue lengths may be added horizontally and include a third 90° flue bend. The flue must be assembled from the standard flue supplied, extension flue kits and second and third 90° flue bends. The flue may be any length providing the total straight length does not exceed 1000 mm.

The flue assembly including the second and third 90° flue bends may be positioned in any horizontal direction to suit the installation.

5b.7 EXTENSION FLUE UPWARDS AND HORIZONTAL USING A THIRD 90° FLUE BEND. (Flue Option 7).
See Fig.5. Frame 7.

Extension flue lengths may be added upwards and horizontally and include a second and third 90° flue bend. The flue must be assembled from the standard flue supplied, extension flue kits, second and third 90° flue bends and a flue adaptor. The flue may be any length providing the total straight length does not exceed 1000 mm.

The horizontal section of flue including the second and third 90° flue bends may be positioned in any horizontal direction to suit the installation.

5c. Vertical Flue System

A optional vertical balanced flue kit with a height of between 100 mm and 3500 mm can be fitted to the appliance. Refer to Section 2.4 and Section 3 – Table 2a. Instructions describing the fitting of the vertical balanced flue system are sent with the flue kit.

6. Air Supply

6.1 The appliance does not require a separate vent for combustion air.

6.2 Installations in cupboards or compartments require permanent vents for cooling purposes – one at high level and one at low level, either direct to outside air or to a room. Both vents must pass to the same room or be on the same wall to the outside air.

6.3 There must be sufficient clearance around the appliance to allow proper circulation of ventilation air. See Section 4.6.

6.4 The minimum free areas required are given as follows.

Fig. 5. Flue options.

FRAME 1
FLUE OPTION 1. Standard horizontal flue.

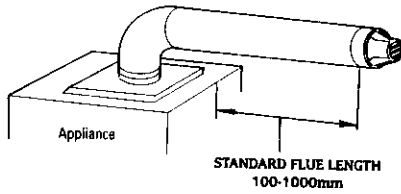

When deciding the flue length required, always measure to the outside of the wall where the flue terminal will be fixed.

When measuring between the centre lines of the flue ducts, allow 83 mm for each flue bend.

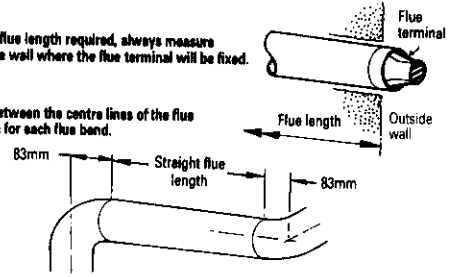

FRAME 2
FLUE OPTION 2. Extension flue horizontal

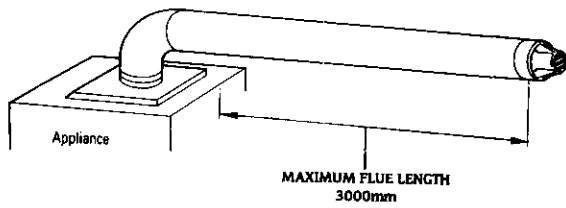

FRAME 3
FLUE OPTION 3. Extension flue upwards and horizontal.

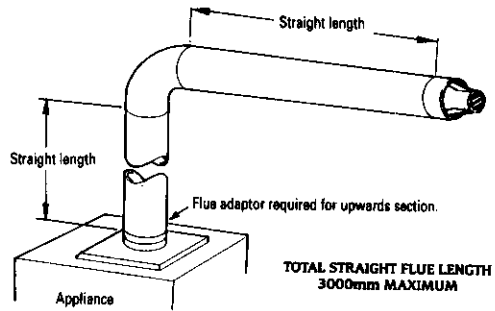

FRAME 4
FLUE OPTION 4. Extension flue horizontal using a second 90° flue bend.

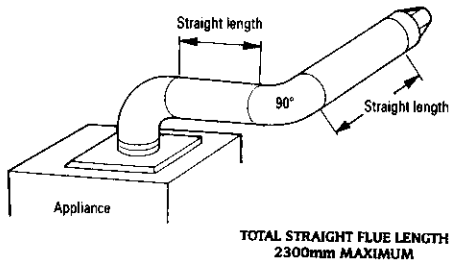

FRAME 5
FLUE OPTION 5. Extension flue upwards and horizontal using a second 90° flue bend.

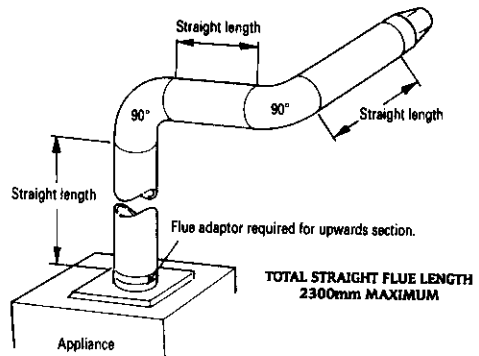

FRAME 6
FLUE OPTION 6. Extension flue horizontal using a second and third 90° flue bend.

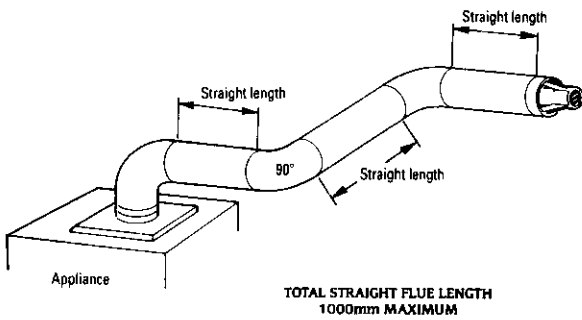

FRAME 7
FLUE OPTION 7. Extension flue upwards and horizontal using a second and third 90° flue bend.

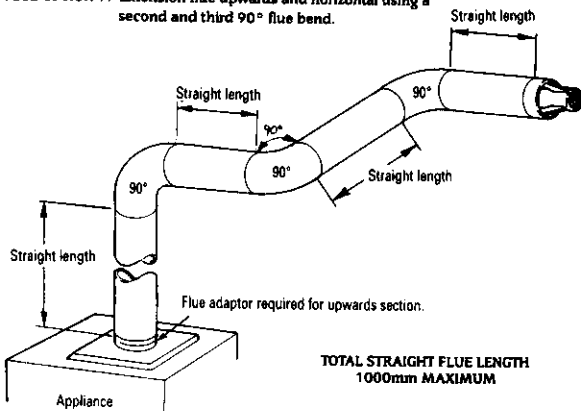

Position of air vents	Air from the room	Air direct from outside
High Level	315 cm ² . (49 in ² .)	158 cm ² . (24 in ²)
Low Level	315 cm ² . (49 in ² .)	158 cm ² . (24 in ² .)

6.5 Refer to BS 6798 and BS 5440:2 for additional information.

7. Sealed System

See Fig.6 and 7.

7.1 The system must comply with the requirements of BS 6798 and BS 5449:1.

7.2 The appliance must not be operated without the system being full of water, properly vented and pressurised.

7.3 The pressure relief valve operates at 3bar (45lb/in²). The discharge must be directed away from electrical items or where it might be a hazard to the user.

7.4 The pressure gauge indicates the system pressure which must be maintained.

7.5 The 10 litre expansion vessel is charged to 0.5 bar and is suitable for a static head of 5m (17.5ft). The pressure can be increased if the static head is greater than 5m (17.5ft).

7.6 With an initial system pressure of 0.5 bar, a system capacity of about 104 litres can be accommodated. Refer to BS 7074 Pt 1 for more information.

7.7 The filling point must be at low level. See Fig 6.

7.8 Any water lost must be replaced. See Fig 7. The connection should be made in the central heating return as close to the appliance as possible.

7.9 The make-up vessel must be fitted with a non-return valve.

7.10 Repeated venting loses water from the system. It is essential that this water is replaced and the system pressure maintained.

7.11 Connections to the mains cold water must not be made without the authority of the local Water Company.

7.12 The pump is set at maximum and must not be adjusted.

7.13 Connections in the system must resist a pressure of up to 3 bar.

7.14 Radiator valves must conform to BS 2767(10):1972.

7.15 Other valves used should conform to the requirements of BS 1010.

7.16 To make use of the extra heat available from the appliance at the end of any demand, it is recommended that a single small radiator be left permanently open.

7.17 If it is required to use the appliance for domestic hot water before the central heating circuit is connected, a 22 mm copper by-pass must be connected between the central heating flow and return. Refer to Section 11.

Fig. 6. Sealed primary water system.

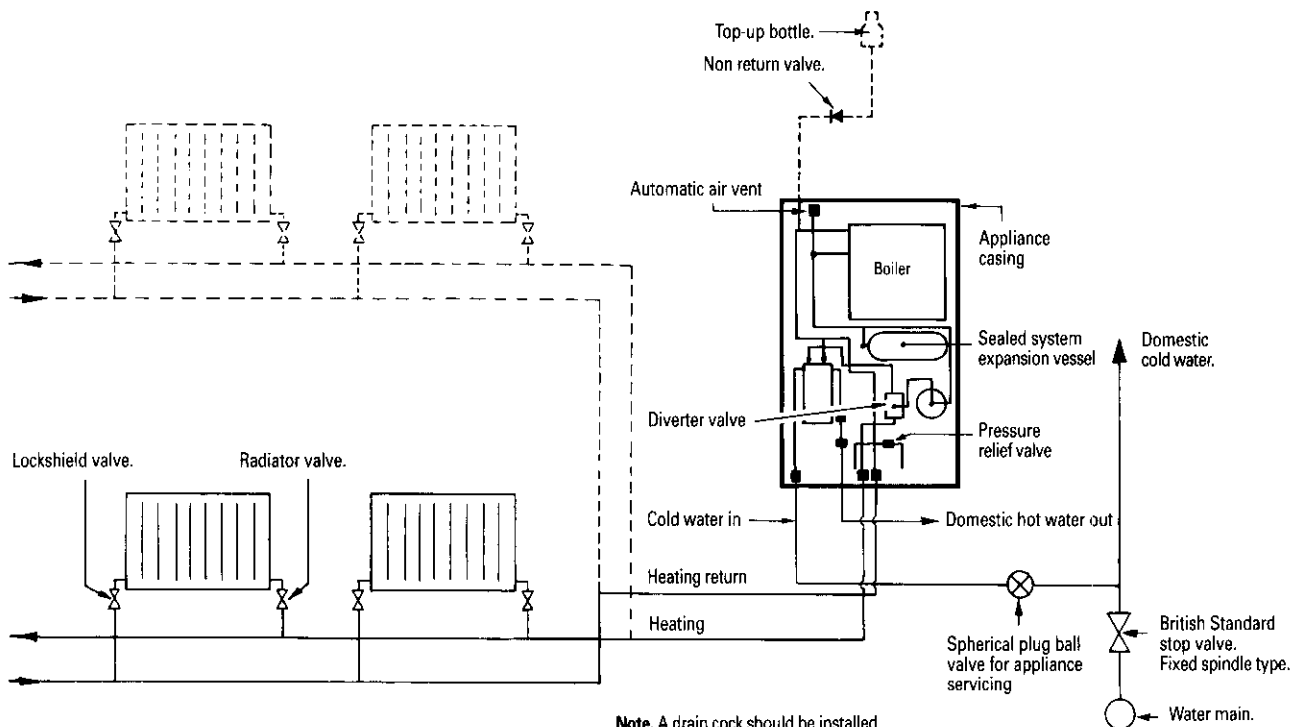

Note. A drain cock should be installed at the lowest point of the heating circuit and beneath the appliance.

Fig. 7. System filling and make-up.

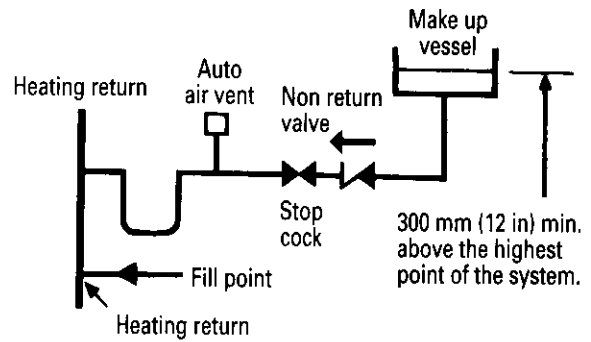
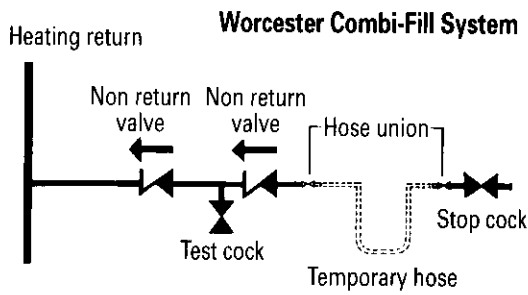

8. Open Vent Primary Systems

See Fig. 8

8.1 The size of the flow and return pipework is given in Section 3 – Table 4. The components required to connect the appliance to an open vent system are available as an optional extra kit.

8.2 The feed and expansion cistern should be arranged so that there is a minimum static head of 0.3 meters (12in.) above the top of the appliance or above the highest point in the heating circuit, whichever is the higher. See Fig. 8.

8.3 The feed and vent pipe should be 22 mm diameter and rise continuously from the appliance to the feed and expansion cistern.

8.4 A pressure relief valve is not required on an open vented sys-

tem. If the pressure relief valve is left in position then a discharge pipe must be fitted which terminates in a position such that any water or steam discharge does not cause a hazard to the occupants or damage electrical components.

8.5 Air within the appliance will be expelled via the feed and vent connection or dissipated into the rest of the system which must be fitted with manual air vents at any high point.

8.6 The pump is set to maximum and must not be reset.

8.7 To make use of the extra heating available from the appliance at the end of any demand, it is recommended that a single small radiator be left permanently open.

8.8 If it is required to use the appliance for domestic hot water before the central heating circuit is connected, a 22 mm copper by-pass must be connected between the central heating flow and return. Refer to Section 11.

Fig. 8. Open vent water system.

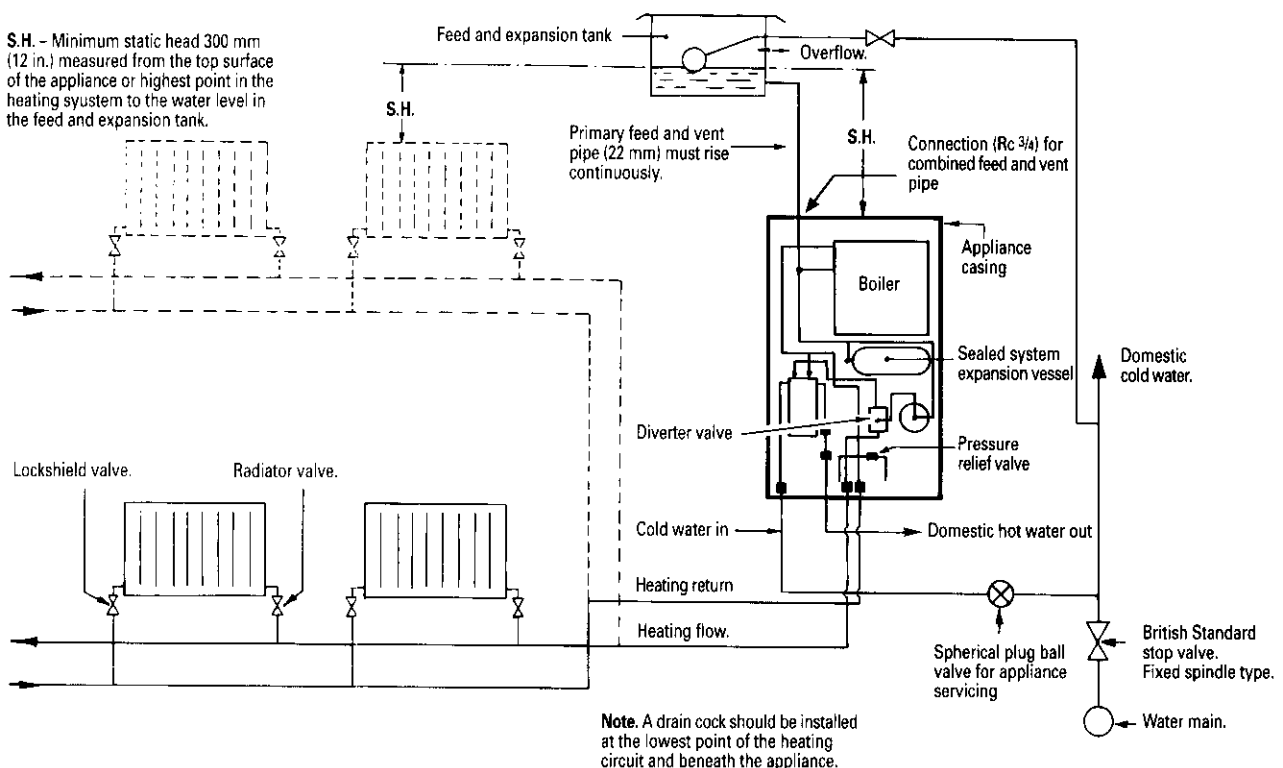

9. Domestic Hot Water

MAINS COLD WATER INLET

Devices capable of preventing the flow of expansion water must not be fitted unless separate arrangements have been made. An expansion vessel connection point (Rc $\frac{1}{2}$) is provided adjacent to the flow switch within the appliance.

A Zilmet Z160 expansion vessel is the preferred type. A thread sealant compatible with potable water must be used.

9.1 The final 600 mm of the mains cold water connection to the appliance should be made in copper tube only.

9.2 The appliance is suitable for a mains pressure of up to 10 bar (150 lb/in 2)

9.3 The appliance is fitted with a mains supply isolating valve.

9.4 The maximum hot water flow rate is 10 litres/min. ($\pm 15\%$) (2.2 gallons/min.)

9.5 In winter (when the mains inlet water temperature is lower) a reduced flow rate at the tap will increase the required delivery temperature.

9.6 It is suggested that long pipe runs to the taps or shower should be insulated to prevent the rapid cooling of hot water after the taps or shower have been turned off.

9.7 Hot and cold taps and mixing valves used with this appliance must be suitable for operating at a pressure of up to 10 bar (150 lb/in 2).

9.8 Anti-syphonage arrangements are normally not necessary. See paragraph 9.10. following.

9.9 Thermostatically controlled or pressure equalising shower valves will guard against the flow of water at too high a temperature.

9.10 The head of a loose head shower must not fall closer than

25 mm (1 in) above the top edge of the bath to prevent its immersion in bath water. Alternatively the shower must be fitted with an anti-syphonage device at the point of the flexible hose connections.

9.11 The supply of hot and cold mains water direct to a bidet is permitted (subject to local Water Company requirements) provided that the bidet is of the over-rim flushing type. The outlet(s) should be shrouded and unable to have any temporary hand held spray attached. No anti-syphonage arrangements are necessary.

9.12 As the maximum temperature of the Water to Water heat exchanger is limited by the control circuit, there is normally no need for water treatment to prevent scale accumulation. In exceptional circumstances a device to prevent scale formation can be fitted. Installation of a scale inhibitor assembly should be in accordance with the requirements of the local Water Company. An isolating valve to allow servicing should be fitted. The water hardness can be determined using a standard test paper or by reference to the local Water Company.

9.13 A miniature expansion vessel (Zilmet R1/2, 160ml, 15bar) can be fitted into the domestic water supply circuit if there is evidence of water hammer.

To fit the Expansion Vessel:

- (i) Remove the appliance front panel. Refer to Section 14.2(a) and Fig.2.
- (ii) Lower the control box. Refer to Section 15.1(b).
- (iii) Unscrew the hexagon headed screw located below the flow switch. See Fig. 36.
- (iv) Screw the expansion vessel into the connection using thread sealant compatible with potable water.

9.14 Note. If it is required to use the appliance for domestic hot water before the central heating circuit is connected, a 22 mm copper by-pass must be connected between the central heating flow and return. Refer to Section 11.

10. Electrical

See Figs. 9, 10 and 11.

10.1 MAINS SUPPLY: 240V ~, 50Hz, 270 watts.

External fuse: 3A. Internal fuse: 3A Fast blow.

10.2 It must be possible to completely isolate the appliance.

10.3 Connection to the mains supply should be via a double pole isolator with a contact separation of 3 mm in all poles and supplying the appliance and controls only.

10.4 The appliance must be earthed.

10.5 Mains Cable: PVC insulated 0.75 mm² (24x0.20 mm) to BS 6500 Table 16.

If a new cable is needed it must be connected into the terminals marked **L** (Brown or Red lead), **N** (Blue or Black lead) and (Green/Yellow or Green) and be held securely in the cable clamp.

Ensure that the earth conductor is longer than the current carrying conductors, so that if the cable slips in its anchorage the current carrying conductors become taut before the earth conductor. For access refer to Section 15.

10.6 The wiring between the appliance and the electrical supply shall comply with current IEE Wiring Regulations, and any local regulations which apply.

10.7 If a room and/or frost thermostat is to be fitted refer to Figs.12 and 13. The thermostats must be suitable for use on mains voltage.

10.8 A fascia mounted programmer is available as an optional extra. Instructions are supplied with the programmer kit.

10.9 An external timeswitch or programmer can be fitted to the appliance.

10.10 SAFETY CHECK

After installation (or in the event of an electrical fault) the electrical system shall be checked for short circuits, fuse failure, incorrect polarity of connections, earth continuity and resistance to earth.

Fig. 9. Wiring diagram – Control panel and fascia. (All components shown viewed from front of appliance)

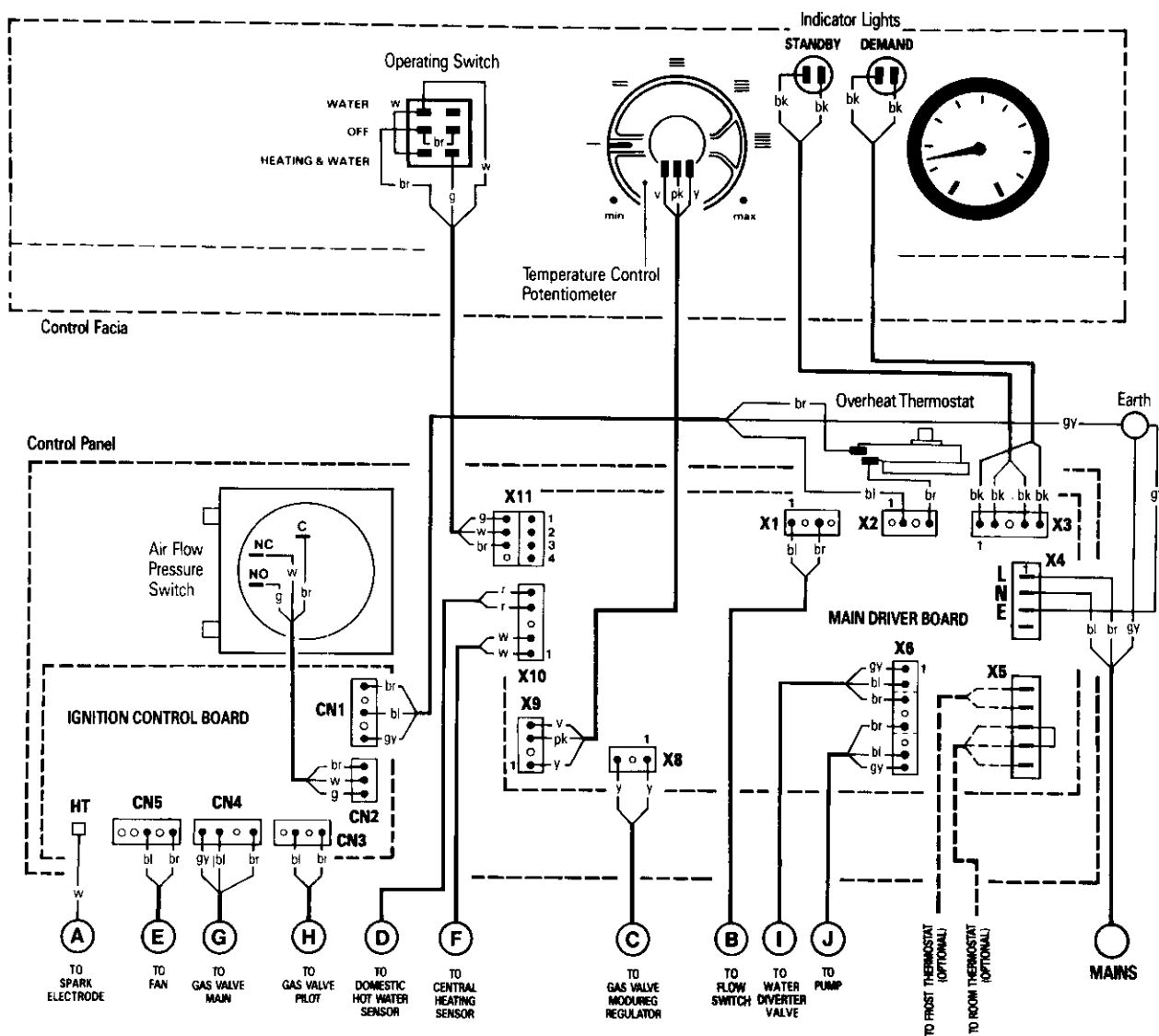

COLOUR CODE

br – brown bl – blue gy – green and yellow bk – black or – orange
r – red w – white y – yellow g – grey v – violet pk – pink

Fig. 10. Wiring diagram – Components outside control panel.
 (All components shown viewed from front of appliance)

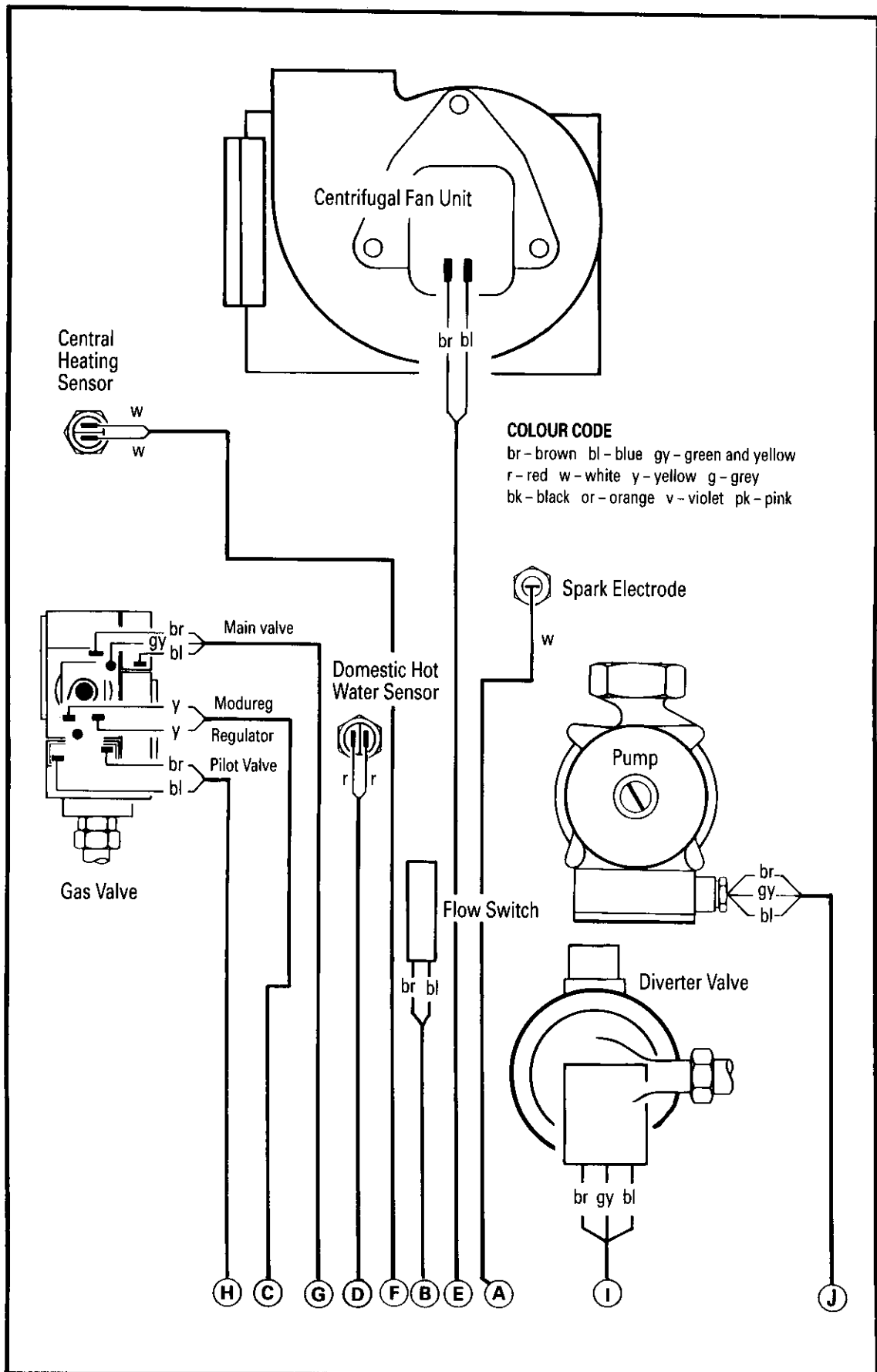

COLOUR CODE
 br - brown bl - blue gy - green and yellow
 r - red w - white y - yellow g - grey
 bk - black or - orange v - violet pk - pink

Fig. 11. Functional flow diagram.

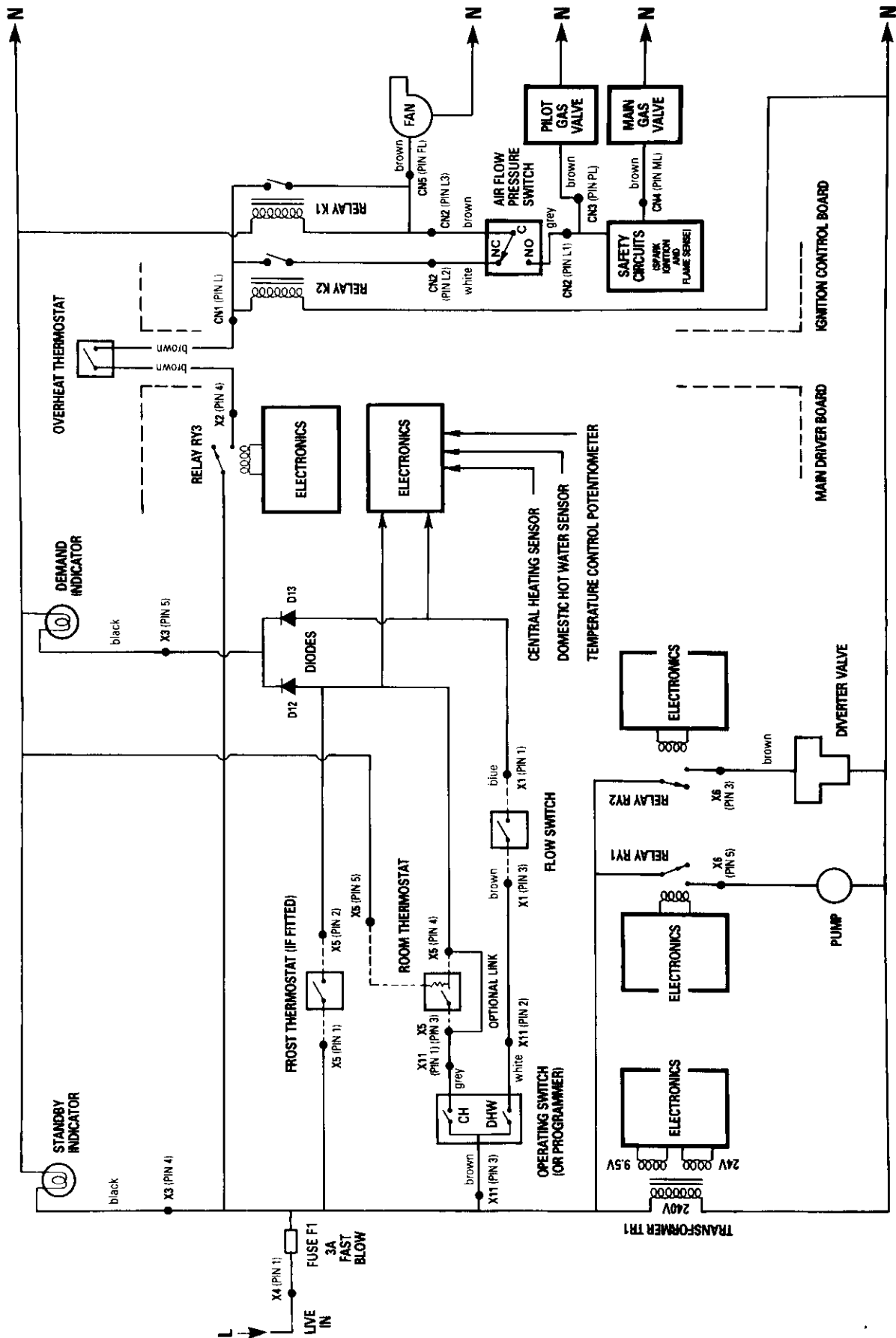

Fig. 12. Room thermostat connections

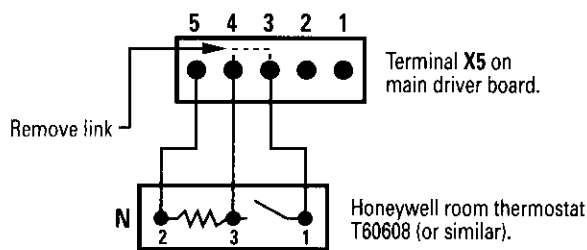
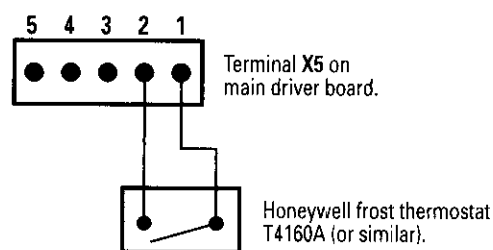

Fig. 13. Frost thermostat connections



11. Installation

The appliance is supplied suitable for fitting to a sealed system. If it is to be fitted to an open vent system refer to paragraph 11.3 and Section 8.

11.1 Flue options.

IMPORTANT. The appliance is supplied with a standard flue assembly including one 90° bend. The standard flue length measured from the side of the appliance casing is from 100 mm to 1000 mm.

EXTENSION FLUE KITS

Extension flue kits and 90° flue bends are available to increase the length and redirect the flue as follows:

- From 1000 mm to 3000 mm straight flue.
- From 1000 mm to 2300 mm when a second 90° flue bend is required.
- Up to 1000 mm when a third 90° flue bend is required.

Refer to Section 3, Table 2 and Section 5b–Flue Options, to determine whether an extension flue kit or kits and an extra 90° flue bend or bends are required.

Note. Extension flue kits, extra 90° flue bends, flue adaptor, flue spacer and air duct supports are all optional extras and all extras required for the installation **must** be available before continuing.

VERTICAL BALANCED FLUE OPTION

A vertical balanced flue option is available. Instructions describing the fitting of the vertical balanced flue system are sent with the vertical flue kit.

The flue must be installed as specified in BS 5440 Pt. 1.

11.2 General fitting.

Check that the appliance carton contains :

- Installer's Instruction Pack
- User's Information Pack
- Appliance with mounting plate and manifold assembly
- Appliance casing bottom panel

Carefully remove the appliance from the package and lay it on its back. Unscrew the four screws and discard the plywood plate.

Unscrew the gas and water connections joining the appliance to the wall mounting plate and manifold assembly at the bottom of the appliance.

Raise the bottom of the appliance and pull out the wall mounting plate and manifold assembly from the appliance.

Check that the gas and water valves are closed. See Fig.14.

Check the position chosen for the appliance is in accordance with the instructions given in Sections 4 and 5a. Also refer to Fig. 2.

Hold the wall mounting plate on the wall on to which the appliance is to be fitted. Check that the mounting plate is horizontal and vertical where indicated. See Fig.16.

Mark the position of the appliance fixing holes (6).

Draw a horizontal line along the top edge of the wall mounting plate and mark the position of the centre line of the appliance from the centre line notch in the wall mounting plate. See Fig. 16.

Before continuing with the installation, it will be necessary to decide which flue option is suitable. Refer to Section 5b and Fig. 5.

Having decided upon the most suitable flue option for the installation, the position of the hole for the flue must now be marked on the wall/walls.

Draw a vertical line in an upwards direction from the centre line notch position extending approx. 250 mm above the wall mounting plate. See Fig.16.

Measure 155 mm upwards from the horizontal line and mark the vertical line. See Fig.16.

This is the Rear Flue centre point position. See Fig.16.

Note: Flue options 1, 2, 4 and 6 require this position to be marked. See Fig. 5.

FLUE OPTIONS 1 and 2. See Fig. 5.

Draw a horizontal line from the rear flue centre point position in the appropriate direction along the wall/walls. Check that it remains horizontal. Measure 135 mm from the junction of the walls and mark a short vertical line. Extend the horizontal line to intersect the vertical line and mark the position.

This is the Side Flue centre point position. See Fig.16.

FLUE OPTIONS 4 and 6. See Fig. 5.

Draw a horizontal line from the rear flue centre point position in the appropriate direction along the wall/walls. Check that it remains horizontal.

Note: If the flue is not close to the wall, ensure it remains horizontal by measuring the rear flue centre point position from the floor and transferring this dimension to the appropriate wall where the flue will terminate. Mark the wall to suit the installation.

This is the flue centre point position. See Fig.16.

For flue options 3, 5 and 7. See Fig. 5.

Note: A flue adaptor is required for these flue options. See Fig.5.

Draw a vertical line in an upwards direction from the centre line notch position extending approximately 250 mm above the position required for the centre line of the horizontal flue duct. See Fig.16

Mark the position on the vertical line to coincide with the centre line position of the horizontal duct.

This is the Rear Flue centre point position. See Fig.16.

FLUE OPTION 3. See Fig. 5.

Draw a horizontal line from the rear flue centre position in the appropriate direction along the wall/walls. Check that it remains horizontal. Measure 135 mm from the junction of the walls and mark a short vertical line. Extend the horizontal line to intersect the vertical line and mark the position.

This is the Side Flue centre point position. See Fig. 16.

FLUE OPTIONS 5 and 7. See Fig. 5.

Draw a horizontal line from the rear flue centre point position in the appropriate direction along the wall/walls. Check that it remains horizontal.

Note: If the flue is not close to the wall, ensure that it remains horizontal by measuring the rear flue centre point position from the floor and transferring this dimension to the appropriate wall, where the flue will terminate. Mark the wall to suit the installation.

This is the flue centre point position. See Fig. 16.

The position for the flue hole should now have been marked on the wall/walls. Continue the installation and drill the six appliance fixing holes 60 mm deep for the No.12 plugs supplied.

Drill the flue hole/holes at 120 mm (4.5 in.) diameter and ensure that it is horizontal through the wall/walls.

If the flue kit for internal fitting is to be used, the hole should be 150 mm (6 in.) diameter.

Plug the holes and fix the appliance mounting plate and manifold

assembly to the wall and check that the assembly is horizontal before tightening the screws.

Notches on the manifold assembly indicate the centre lines of the valves. Transfer these marks to the wall to aid the alignment of the pipework.

Remove the gas cock and fit the appropriate connector fitting. Refit the cock.

If pre-plumbing the pipework, loosen the valve locknuts and arrange the pipework so that there can be some slight vertical movement of the valves when connected to the pipework. Suitably restrain the pipework after connecting the appliance.

Fig. 14. Valve operation.

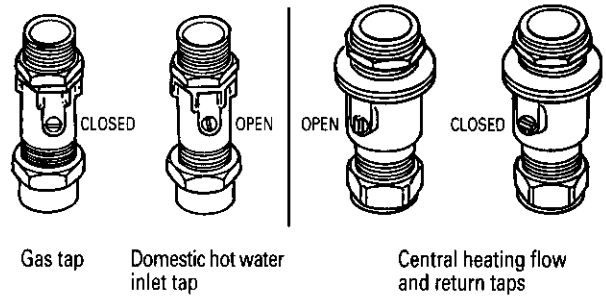
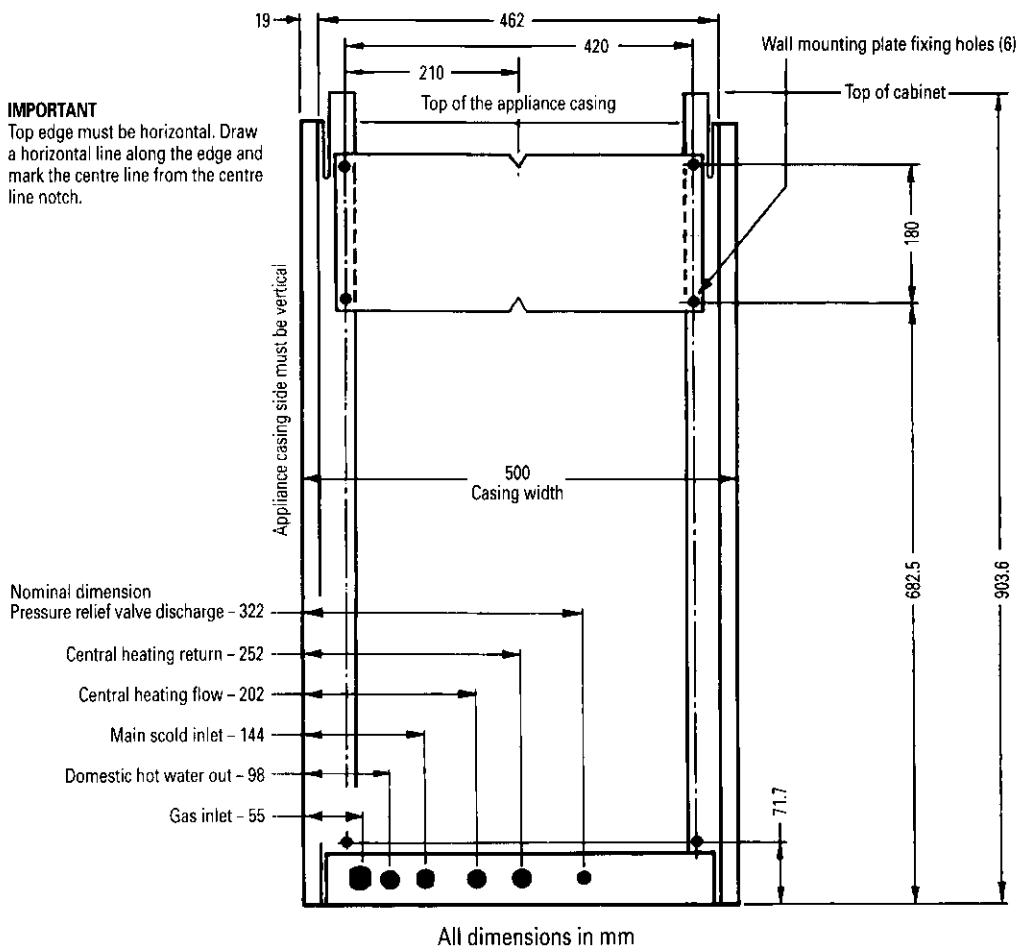

Fig. 15. Appliance mounting plate and manifold assembly.

IMPORTANT

Top edge must be horizontal. Draw a horizontal line along the edge and mark the centre line from the centre line notch.



Pre-plumbing is not advised if movement is not available.

Pipework running up the back of the appliance must be arranged to pass to one side of the flue duct assembly when a Rear Flue is to be used. See Fig 2.

Pipework can only run horizontally outside the limits of the

appliance casing. It is important that the pipes are not fixed using clips which space them away from the wall.

The gas and water pipes may now be connected to the manifold. Before the appliance is fitted to the wall, thoroughly flush the central heating system and the mains cold water supply pipe.

Fig. 16. Marking the flue positions for all flue options.

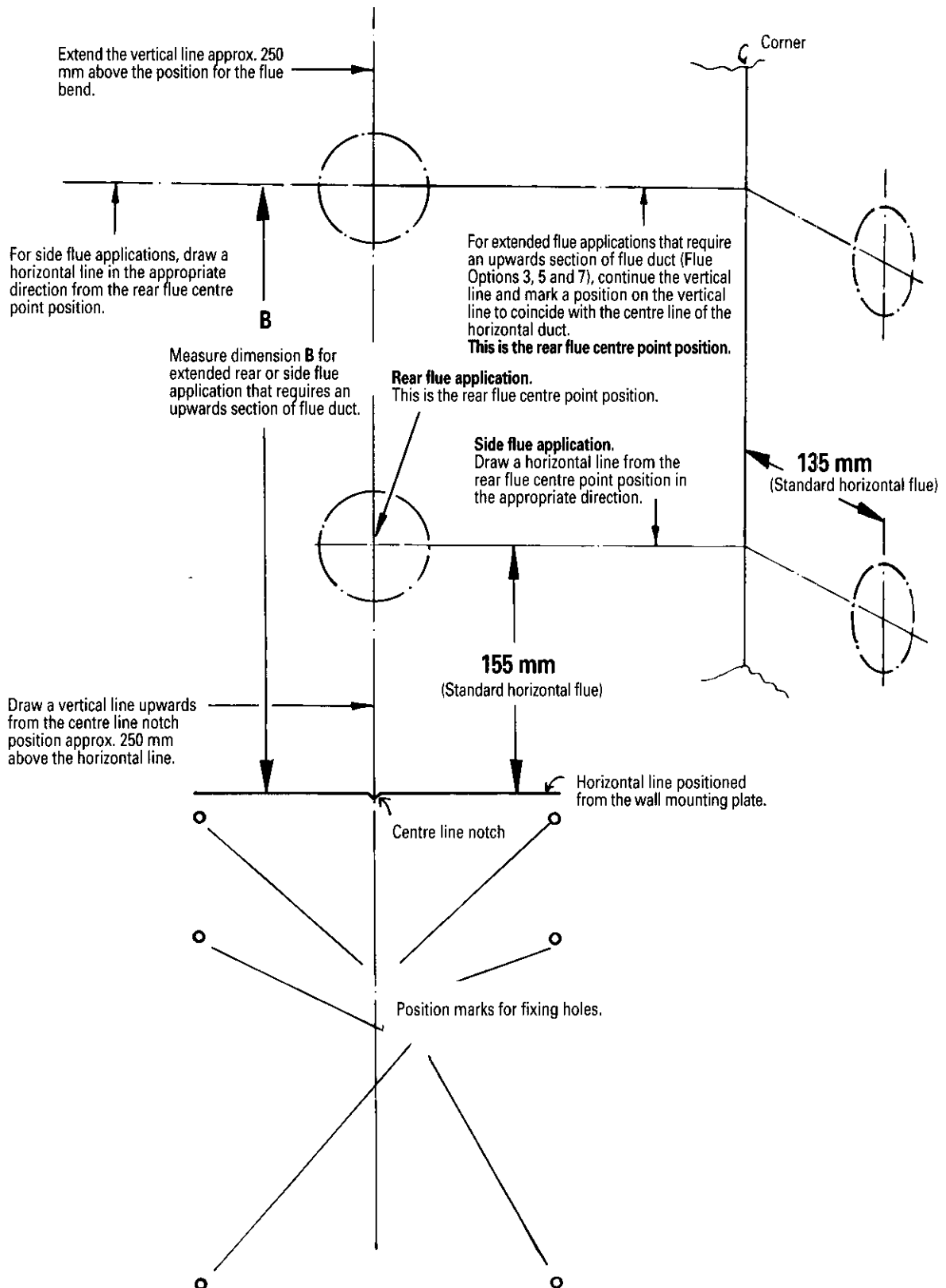

11.3 Fixing the appliance for all flue options.

Place the flue clamping ring around the flue spigot. Do not tighten the clamping ring screw at this stage.

Lift the appliance onto the mounting plate and manifold assembly ensuring that it is properly entered onto the top supports.

Remove the transit brackets from each side of the appliance (each held by three screws). Remove the fixing screw from the underside and slacken the two side fixing screws holding each bracket. Remove the bracket and discard.

Hold the bottom of the appliance off the wall slightly so that the connections can be aligned and entered. Ensure the valve cocks face downwards. Fully tighten the gas and water connections and the valve locknuts. Always support the appliance pipework when tightening.

Pass a 15 mm pipe through the manifold plate and connect it to the pressure relief valve discharge compression fitting. See Fig. 17. Ensure any discharge will not fall onto electrical components or where it might be a hazard to the user.

Fit the casing bottom panel using the screws supplied. See Fig. 18. The panel and screws are packed separately in the appliance carton.

Remove the cabinet front panel from the appliance by pulling it away from the clips at the bottom of the casing and lifting it off the top supports.

Sealed System

Remove the inner casing cover by removing the five screws.

Unscrew and discard the automatic air vent cap. See Fig. 19a. Replace the inner casing cover immediately.

Open Vent System

Remove the inner casing cover by removing the five screws. Remove the air distribution plate, fan and flue hood assembly by following the instructions in Section 14.2 (c, d and e). Undo the three screws securing the casing sealing plate. Discard the plate and retain the gasket. See Fig. 19b. Remove and discard the automatic air vent. See Fig. 19a. Fit the pre-formed pipe (optional extra) using the three screws, washers and gasket. See Fig. 19c. Connect the feed and expansion tank. Replace the inner casing cover.

Domestic Hot Water Use Only.

If it is required to use the appliance for domestic hot water before the central heating is connected, a 22 mm copper by-pass pipe at least 2 meters long must be connected between the central heating flow and return.

OPTIONAL FLUE KIT FOR INTERNAL FITTING.

If the flue kit for internal fitting, supplied as an optional extra, is to be used, refer to Section 11.6. This section describes the assembly and fitting of the flue components.

Fig. 17. Pressure relief valve.

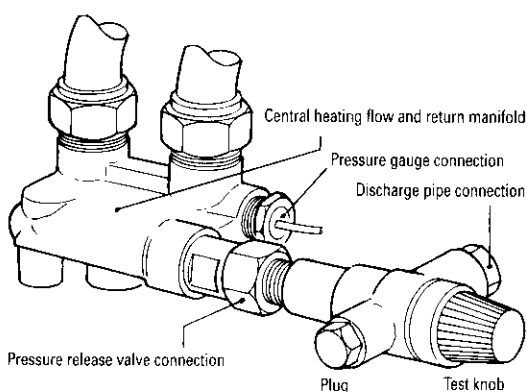

General information and guide lines for all flue options.

Check the contents of the standard flue kit and extension flue kit/kits against the respective packing list.

Remove all packaging from the ducts, flue bend/bends and flue terminal assembly.

Note: The air duct is 100 mm diameter and the flue duct is 50 mm diameter.

WARNING: The air duct, flue duct and flue bend/bends are manufactured from aluminium and must be handled appropriately.

Measure and cut the air and flue ducts to length. Ensure the cuts are square and free from burrs. Always check the dimensions before cutting the duct.

Do not cut the expanded end of the extension air or flue ducts unless instructed otherwise.

The air and flue ducts supplied with the standard flue kit must be adjacent to the first flue bend or flue adaptor at the appliance. See Figs. 21 or 25.

Note: A flue adaptor must be fitted for flue options 3, 5 and 7. See Fig. 5. The adaptor fits into the spigot on top of the appliance casing. Fix in position with the clamping screw and ensure the adaptor is correctly located against the stop.

When sealing this joint refer to Fig. 25.

When assembling extension air and flue ducts, ensure they are correctly located in the socketed joints. See Fig. 25.

Measure the length of the air and flue ducts from the end that will be fixed into the flue bend or adaptor fitted to the appliance.

Before cutting the air or flue ducts ensure the final expanded section is at least 100 mm clear of the flue terminal end or flue bends. If it is not, reduce the length of the adjacent air and flue ducts by cutting off from the non-expanded end the amount necessary to give the minimum clearance. See Fig. 25

Take care to seal all the flue joints where indicated. See Fig. 25. To seal the flue joints, disengage the joint and apply a smear of silicone sealant around the duct. See Fig. 25.

If the flue assembly is longer than 1500 mm, the flue duct must be supported within the air duct with a flue spacer (available as an optional extra). See Fig. 25.

On final assembly, the air duct must be adequately supported. Air duct support brackets are available as an optional extras. See Section 5b for flue spacer and air duct support bracket part numbers.

The optimum route for the flue must be measured and sufficient extension flue/flues and other components ordered to facilitate the satisfactory installation of the flue. See Section 5b for parts identification and part numbers.

Fig. 18. Casing bottom panel assembly.

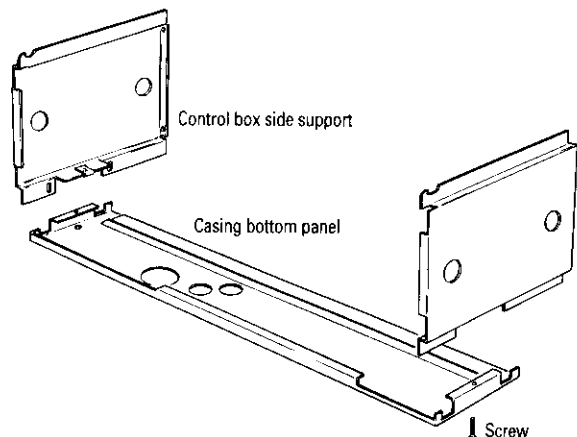

Fig. 19a. Automatic air vent.

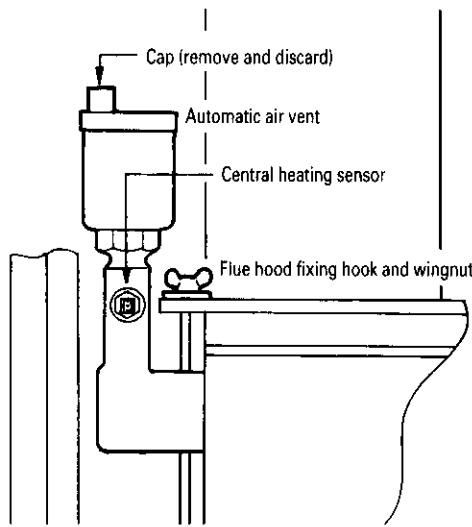

Fig. 19b. Cover plate (Sealed Systems).

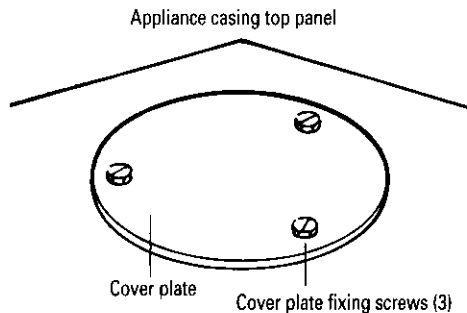
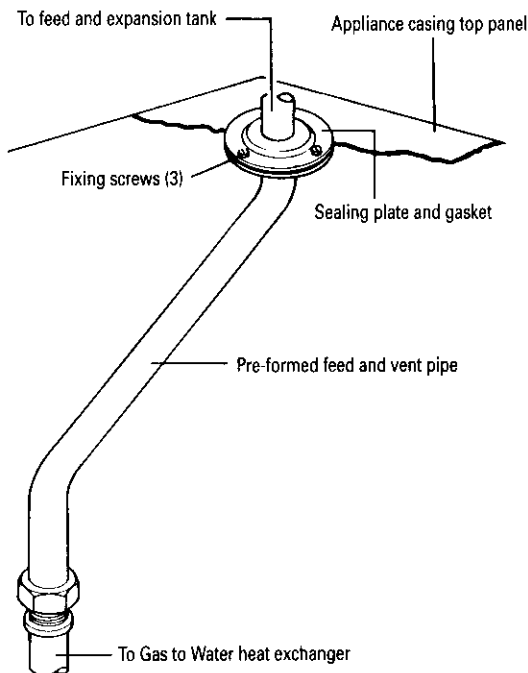

Fig. 19c. Pipe connection for open vent systems.



Because of site conditions it may be necessary to deviate from the following method of installation. Joints must be sealed and fixed where applicable.

Now turn to the appropriate section to install the required flue system:

Section 11.4 Fitting the Standard Horizontal Flue Assembly

or

Section 11.5 Fitting an Extension Flue and Extra 90° Flue Bend or Bends

11.4 Standard horizontal flue (Flue option1)

See Figs. 5 and 20.

Air and flue duct preparation.

The standard flue assembly, supplied with the appliance, accommodates a flue length of up to 1000 mm measured from the side of the appliance casing.

SIDE FLUE ASSEMBLY.

Measure the distance from the side of the appliance casing to the outside surface of the wall. Dimension A. See Fig.20.

Air duct length = (A + 192) mm .

Flue duct length = (A + 239) mm.

Do not cut the drilled end of the air duct.

Assemble the air duct to the flue terminal. Drill through the holes in the flue terminal into the air duct with the drill provided. Apply a smear of silicone sealant to the end of the air duct and fix into the flue terminal using the screws provided. See Fig.21.

Fit the flue duct into the flue bend. Ensure it is located correctly against the stop. Drill two holes through the holes in the bend. See Fig.21.

Fit the air duct over the outside of the flue duct. Ensure it is located correctly against the stop. Drill two holes through the holes in the air duct.

Disconnect the air and flue ducts from the flue bend.

Apply a smear of silicone sealant around the outside of the flue duct. Fit the flue duct into the flue bend and fix with the screws provided. See Fig. 21.

From inside, pass the flue duct through the hole in the wall and fit the flue bend into the spigot on top of the appliance casing

When sealing this joint refer to Fig. 21.

Align the outlet in the direction of the flue terminal. Do not tighten the clamping screw at this stage.

Apply a smear of silicone sealant around the inside of the air duct.

From outside, pass the air duct and flue terminal assembly through the hole in the wall. Ensure the flue duct fits into the flue terminal and the air duct fits over the flue bend. Fix with the screws provided. See Fig. 21.

Ensure the flue bend is correctly located and aligned in the flue spigot. Adjust the clamping ring so that it is level with the top of the flue spigot and tighten the clamping screw.

Do not apply a smear of silicone sealant around the end of the flue duct that fits into the flue terminal.

Make good the internal and external brickwork or rendering.

REAR FLUE ASSEMBLY.

Measure the distance from the rear of the appliance casing to the outside surface of the wall. Dimension A. See Fig.20 .

Air duct length = (A + 80) mm .

Flue duct length = (A + 127) mm.

Do not cut the drilled end of the air duct.

Continue the installation as previously described for the Side Flue Assembly.

Make good the internal and external brickwork or rendering.

11.5 Fitting extension flues and extra 90° flue bend or bends.

The installation can now be continued by following the instructions for the appropriate Flue Option listed in the table below. See also Fig. 5.

Option No.	Flue option	Section
2	Extension Flue Horizontal (Side or Rear).	11.5.1
3	Extension Flue Horizontal and Upwards.	11.5.2
4	Extension Flue Horizontal using a second 90° flue bend.	11.5.3
5	Extension Flue Upwards and Horizontal using a second 90° flue bend.	11.5.4
6	Extension Flue Horizontal using a third 90° flue bend.	11.5.5
7	Extension Flue Upwards and Horizontal using a third 90° flue bend.	11.5.6

11.5.1 EXTENSION FLUE HORIZONTAL (Flue Option 2)

See Fig. 20.

Note: The length of flue when measured from the side of the appliance casing must not exceed 3000 mm.

SIDE FLUE ASSEMBLY.

Measure the distance from the side of the appliance casing to the outside surface of the wall. Dimension A. See Fig 20.

Air duct length = $(A + 192)$ mm,

Flue duct length = $(A + 239)$ mm.

Cut the air and flue ducts to length.

Assemble the air ducts.

Continue the installation by following the procedure as described in Section 11.4.

If necessary, assemble and check the air duct length.

Drill two holes through the holes in the expanded end of each air duct with the drill provided.

Disengage each air duct and apply a smear of silicone sealant around of the air duct to seal the joint. See Fig.25.

Reassemble and fix the air ducts together with the screws provided.

Assemble the flue ducts.

Follow the procedure for measuring, cutting, sealing and fixing, as described in Section 11.4.

Note. If the extension is longer than 1500 mm a flue duct support must be fitted before the ducts are finally assembled. The flue duct support must be fitted half way along the flue duct for effective support. See Fig.25.

Assemble the flue duct into the air duct.

Fit the air and flue ducts into the flue terminal. Drill through the holes in the flue terminal into the air duct with the drill provided.

Apply a smear of silicone sealant to the end of the air duct and fix into the flue terminal using the screws provided. See Fig.25.

Do not smear silicone sealant around the end of the flue duct that fits into the flue terminal.

Fit the flue duct into the flue bend. Ensure it is located correctly against the stop. Drill two holes through the holes in the bend. See Fig.21.

Fit the air duct over the outside of the flue bend. Ensure it is located correctly against the stop. Drill two holes through the holes in the air duct.

Apply a smear of silicone sealant around the outside of the flue duct and the inside of the air duct. See Fig.21.

Fit the flue duct into the flue bend and fix with the screws provided.

Fit the air duct over the flue bend and fix with the screws provided. See Fig.21.

Fix the flue assembly to the appliance.

Pass the assembly through the wall from inside the building.

Align the flue bend with the spigot on top of the appliance casing. Ensure that the bend is correctly located against the stop. See Fig. 21. Adjust the clamping ring so that it is level with the top of the flue spigot and tighten the clamping screw. See Fig. 21.

Do not use silicone sealant at this joint.

Important. Flues longer than 1500 mm must be adequately supported. Air duct support brackets are available as an optional extra. See Section 5b.

Make good the internal and external brickwork or rendering.

REAR FLUE ASSEMBLY.

Measure the distance from the rear of the appliance casing to the outside surface of the wall. Dimension A. See Fig.20.

Air duct length = $(A + 80)$ mm,

Flue duct length = $(A + 127)$ mm,

Follow the procedure previously described for the Side Flue Assembly.

11.5.2 EXTENSION FLUE UPWARDS AND HORIZONTAL (Flue Option 3). See Fig. 26.

Note: The two flue lengths when added together must not exceed 3000 mm.

Follow the instructions in Section 11.4.

SIDE FLUE ASSEMBLY.

Upwards Section

Measure the distance from the horizontal line marked on the wall from the wall mounting plate to the centre line of the horizontal duct Dimension B. See Figs.16 and 26.

Air duct length = $(B - 158)$ mm.

Flue duct length = $(B - 151)$ mm.

Horizontal Section

Measure the distance from the centre line of the appliance to the outside surface of the wall. Dimension C. See Fig.26.

Air duct length = $(C - 58)$ mm.

Flue duct length = $(C - 11)$ mm.

The first section of horizontal air duct fitted adjacent to the flue bend will not require an expanded end.

Cut off the expanded end from this section only.

Continue the installation by following the procedure as described in Section 11.5.1.

Measure the air duct length required

Upwards Section. From the end that will be fixed into the flue adaptor.

Horizontal Section. From the end that will be fixed into the flue bend.

Continue the installation by following the procedure described in Section 11.5.1 to assemble the flue ducts.

Fix the upwards section of duct.

Apply a smear of silicon sealant to one end of the air and flue ducts as follows:

Air duct – To the inside of the end with the fixing holes.

Flue duct – To the outside of one end.

Fit the flue duct into the flue adaptor. Ensure it is correctly located against the stop.

Note: Fixing screws (top or bottom) for this section of flue duct are not required. See Fig.25.

Fit the air duct over the flue adaptor. Ensure it is correctly located against the stop and is vertical.

Drill two holes through the existing holes in the air duct and into the flue adaptor with the drill provided. Fix together with the screws provided.

Fix the Horizontal Section.

Refer to Section 11.5.1 and follow the instructions to assemble the flue duct into the air duct

Apply a smear of silicone sealant to the flue elbow – inside to seal the flue duct and outside to seal the air duct.

Pass the assembly through the wall from inside the building.

Align the flue bend with the upwards section of duct and fit into the air and flue ducts.

Ensure the bend is correctly located against the stop. See Fig.25.

Drill two holes through the air duct and flue bend with the drill provided. Fix together with the screws provided.

REAR FLUE ASSEMBLY.

Measure the distance from the rear of the appliance casing to the outside of the wall. Dimension A. See Fig.26

Air duct length = (A + 80) mm

Flue duct length = (A + 127) mm

Follow the procedure previously described for the Side Flue Assembly.

Fig. 20. Standard horizontal flue (Option 1) and extension flue horizontal (Option 2). Air and flue duct lengths.

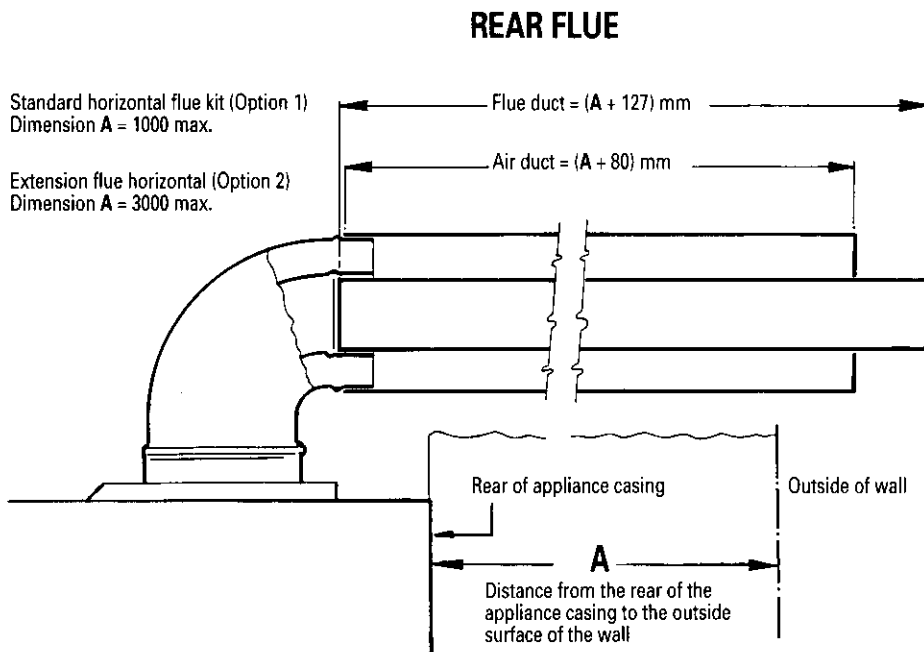
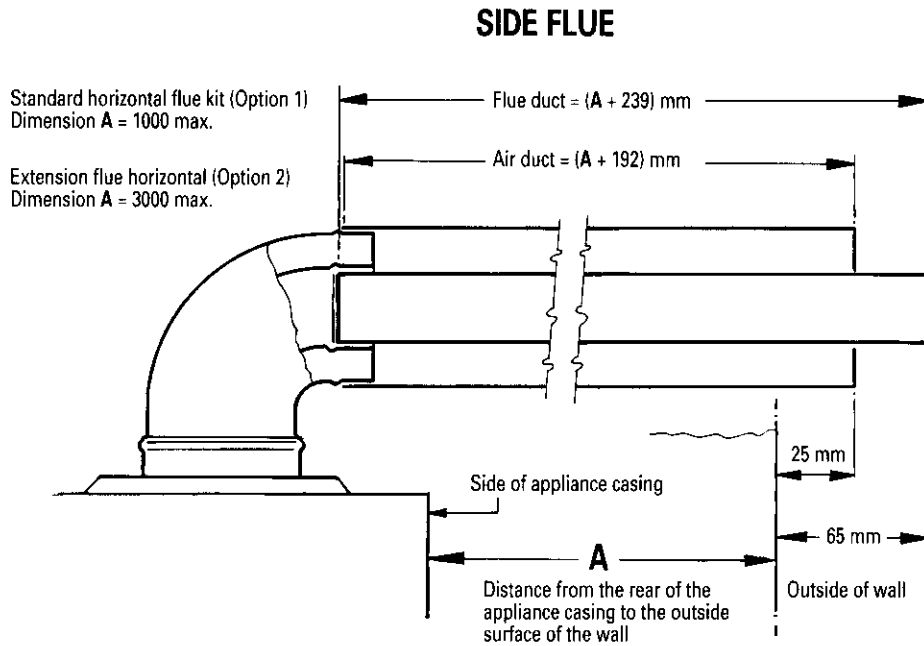
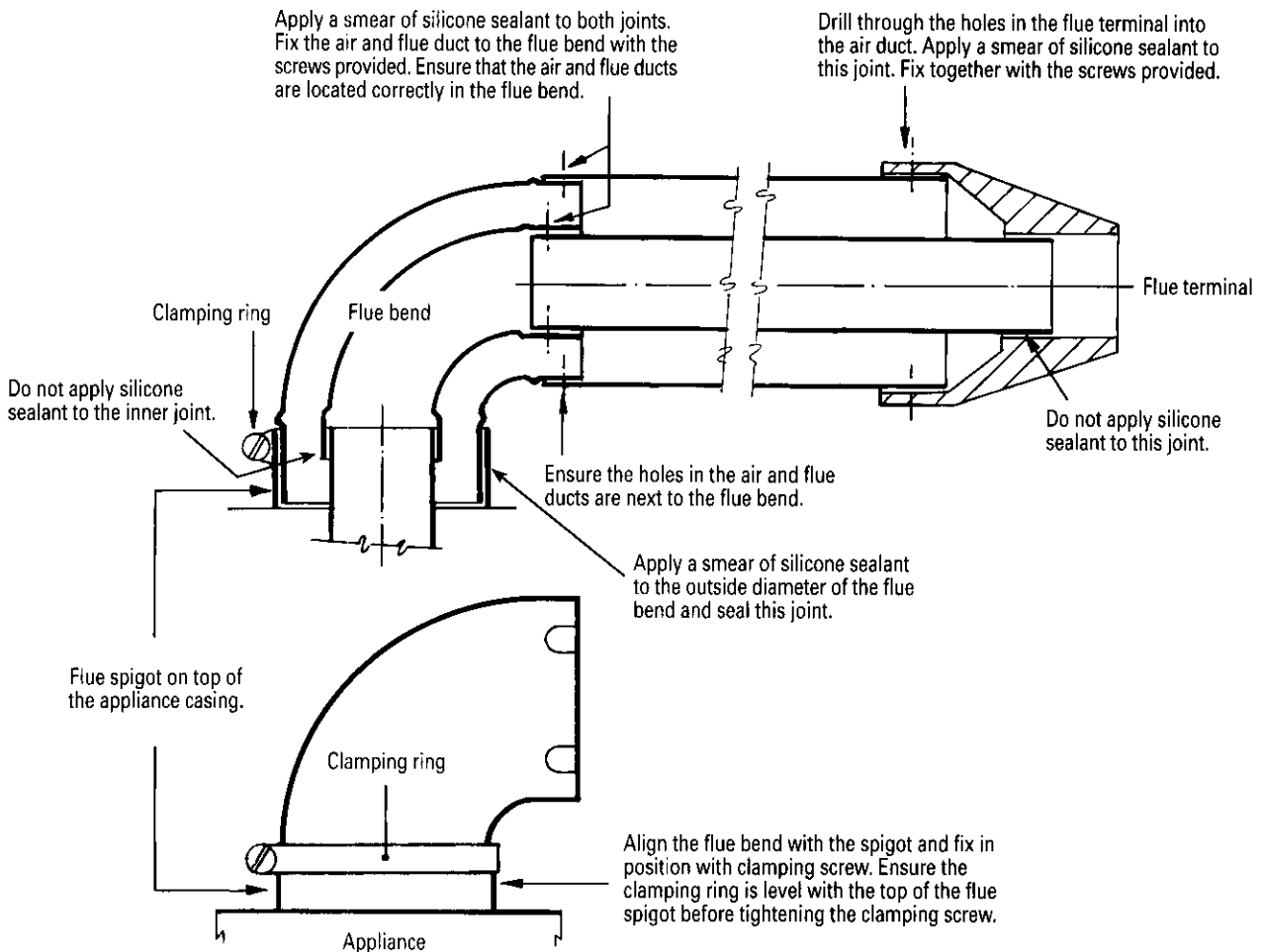

Fig. 21. Fixing the flue terminal and the flue bend to the air duct, flue duct and flue spigot on top of the appliance casing.



11.5.3 EXTENSION FLUE HORIZONTAL USING A SECOND 90° FLUE BEND (Flue Option 4.)

See Fig. 27.

Note: The two flue lengths when added together must not exceed 2300 mm.

First flue length from the appliance to the second flue bend.

The first flue bend will fit into the spigot on top of the appliance. Measure the distance between the centre of the flue spigot on top of the appliance casing and the centre of the second flue bend. Dimension D. See Fig. 27.

Note: Dimension D must not be less than 210 mm.

Air duct length = (D - 166) mm

Flue duct length = (D - 152) mm

Second flue length.

Measure the distance between the centre of the second flue bend and the outside surface of the wall. Dimension C.

Air duct length (rear flue) = (C - 80) mm

Air duct length (side flue) = (C - 58) mm

Flue duct length (rear flue) = (C - 127) mm

Flue duct length (side flue) = (C - 11) mm

Assemble the air and flue ducts as described in Sections 11.5, 11.5.1 and 11.5.2 with attention to the following:

Fit the flue terminal and second flue bend to the second flue length.

Ensure the air duct is fixed at both ends and the flue duct fixed to the flue bend only. Fix with the screws provided. See Figs. 25 and 27.

Fit the first flue length to this flue bend followed by the first flue bend.

Ensure the first flue bend is aligned correctly with the appliance.

Fix each end of the air duct to the bends with the screws provided.

The flue duct must fit correctly between the flue bends.

The duct is trapped between the flue bends and does not require fixing screws. See Fig. 28.

Follow the procedure for fixing the assembly to the appliance as described in Section 11.5.1.

Fig. 22. Terminal assembly for internal fitting of the flue.

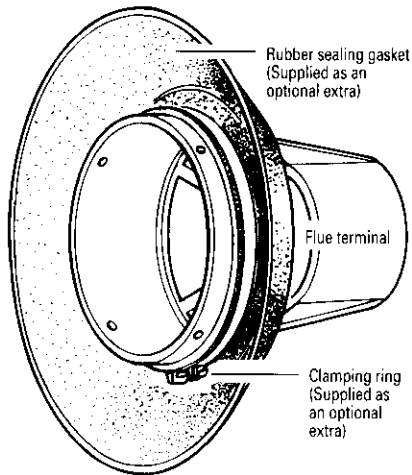
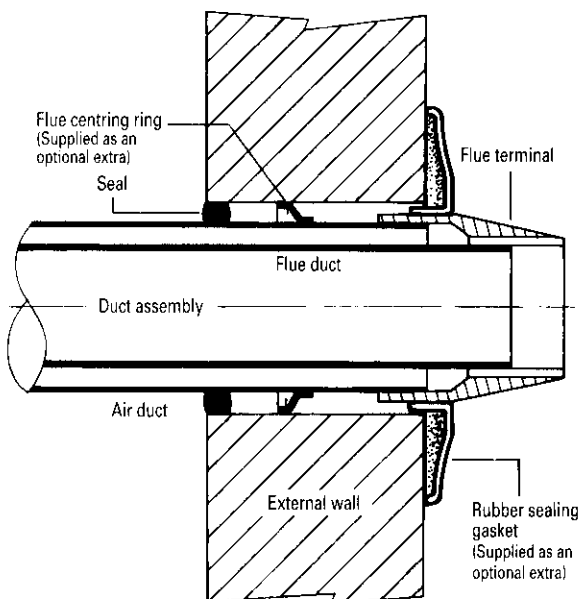

Fig. 23. Duct and terminal assembly for internal fitting of the flue.



11.5.4 EXTENSION FLUE UPWARDS AND HORIZONTAL USING A SECOND 90° FLUE BEND (Flue Option 5)
See Fig. 29.

Note: The three flue lengths when added together must not exceed 2300 mm.

Follow the instructions in Section 11.5 but use the following dimensions:

Measure the distance from the horizontal line marked on the wall from the wall mounting plate to the centre line of the horizontal duct. Dimension **B** mm. See Figs. 16 and 29.

Upwards Section:

Air duct length = $(B - 158)$ mm.

Flue Duct length = $(B - 151)$ mm.

Horizontal Section:

Measure the first and second horizontal duct lengths by following the procedure described in Section 11.5.3. Dimensions **D** and **C**.

Assemble the air and flue ducts as described in Section 11.5.

Follow the assembly procedure as described in Section 11.5.3.

Follow the procedure for fitting the flue adaptor and upwards section of the flue duct as described in Section 11.5.2.

Follow the procedure for fixing the assembly to the upwards section of the flue duct as described in Section 11.5.2. See Figs. 25 and 29.

11.5.5 EXTENSION FLUE HORIZONTAL USING A SECOND AND THIRD 90° FLUE BEND.

(Flue Option 6) See Fig. 30.

Note: The three flue lengths when added together must not exceed 1000 mm.

Follow the instructions in Section 11.5.

Refer to Section 11.5.3 and measure Dimension **D**.

For this flue option Dimension **D** is the centre distance between each flue bend. The dimension may vary between each bend. The minimum dimension must not be less than 210 mm.

First and second flue lengths:

Air duct length = $(D - 166)$ mm.

Flue duct length = $(D - 152)$ mm.

Third flue length:

Refer to Section 11.5.3 and measure Dimension **C**.

Air duct length (rear flue) = $(C - 80)$ mm

Air duct length (side flue) = $(C - 58)$ mm

Flue duct length (rear flue) = $(C - 127)$ mm

Flue duct length (side flue) = $(C - 11)$ mm

Assemble the air and flue ducts as described in Section 11.5.

Before fixing each section of duct, ensure each flue bend is aligned correctly.

Follow the procedure for fixing the assembly to the appliance as described in Section 11.5.1. See Figs. 25 and 30.

11.5.6 EXTENSION FLUE UPWARDS AND HORIZONTAL USING A SECOND AND THIRD 90° FLUE BEND

(Flue Option 7) See Fig. 31.

Note: The four flue lengths when added together must not exceed 1000 mm.

Follow the instructions in Section 11.5.

Refer to Section 11.5.2, and measure Dimension **B**. See Fig. 16.

Upwards Section:

Air duct length = $(B - 158)$ mm

Flue duct length = $(B - 151)$ mm

Horizontal Section:

To find the length of the first, second and third flue ducts follow the procedure as described in Section 11.5.5. and measure dimensions **D** and **C**.

First and second flue length:

Air duct length = $(D - 166)$ mm

Flue duct length = $(D - 152)$ mm.

Third flue length:

Refer to Section 11.5.3 and measure Dimension **C**.

Air duct length (rear flue) = $(C - 80)$ mm

Air duct length (side flue) = $(C - 58)$ mm

Flue duct length (rear flue) = $(C - 127)$ mm

Flue duct length (side flue) = $(C - 11)$ mm

Assemble the air and flue ducts as described in Section 11.5.

Before fixing each section of duct, ensure each flue bend is aligned correctly

Follow the procedure for fitting the flue adaptor and upwards section of the flue duct as described in Section 11.5.2.

Follow the procedure for fixing the assembly to the upwards section of the flue duct as described in Section 11.5.2. See Figs. 25 and 31.

11.6 Flue kit for internal fitting (Optional extra)

If it is required to fit the flue system from inside the building, the hole in the wall must be 150 mm (6 in.) diameter.

Measure and cut the ducts as previously described in Section 11.4.

Assemble the air and flue ducts to the flue terminal and flue bend as previously described. See Section 11.4

Fit the rubber sealing gasket to the flue terminal. Centralise the gasket and tighten the clamping ring. See Fig. 22.

Pass the assembly through the wall from inside the building so that the gasket flange is against the outside face of the wall. See Fig. 23.

Slide the flue centring ring, available from Worcester Heat Systems, onto the air duct and tighten the screw. See Fig. 23.

Align the flue outlet bend with the spigot on top of the appliance. Ensure the bend is correctly located against the stop. See Fig. 21.

Adjust the clamping ring so that it is level with the top of the flue spigot and make good the internal brickwork.

Fig. 24. Appliance casing and control equipment fixings.

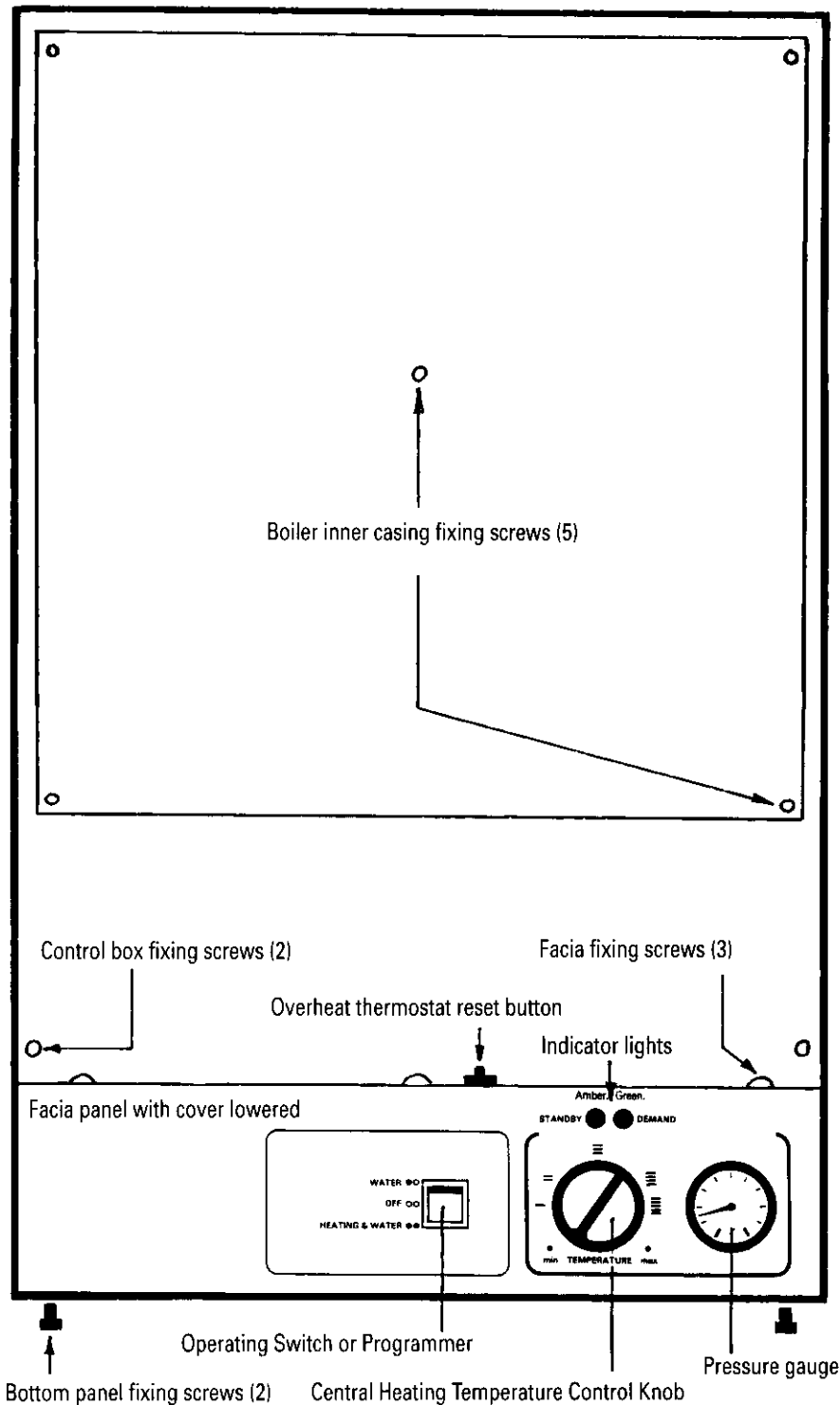

Fig. 25. Typical extension flue assembly showing horizontal section and upwards section.

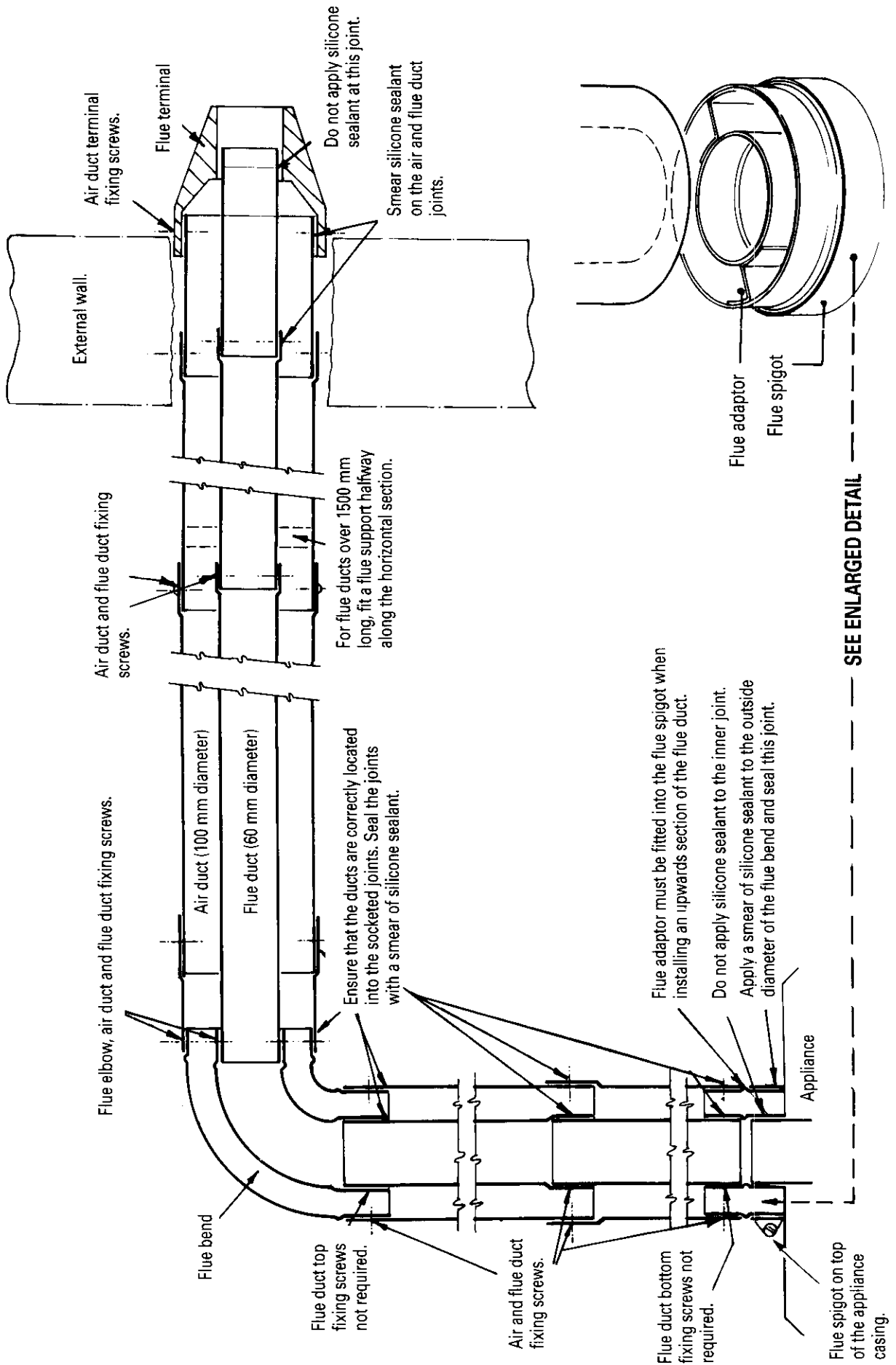

Fig. 26. FLUE OPTION 3. Extension flue upwards and horizontal.

The two flue lengths when added together must not exceed 3000 mm.

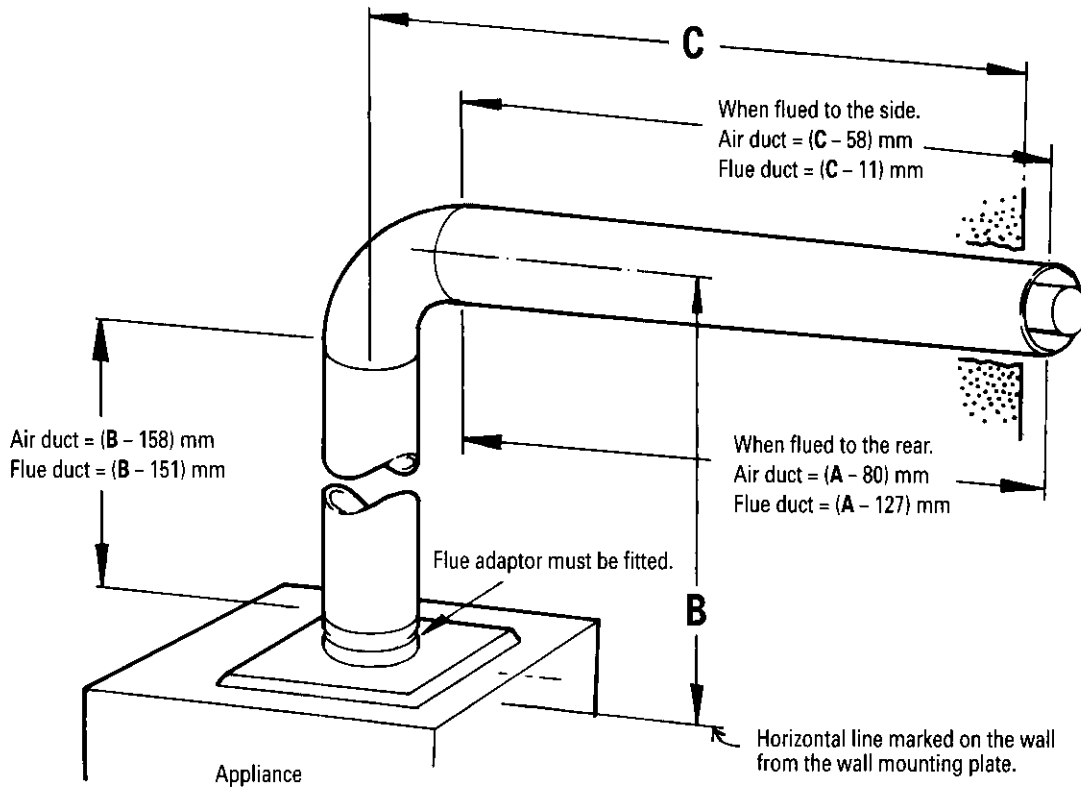
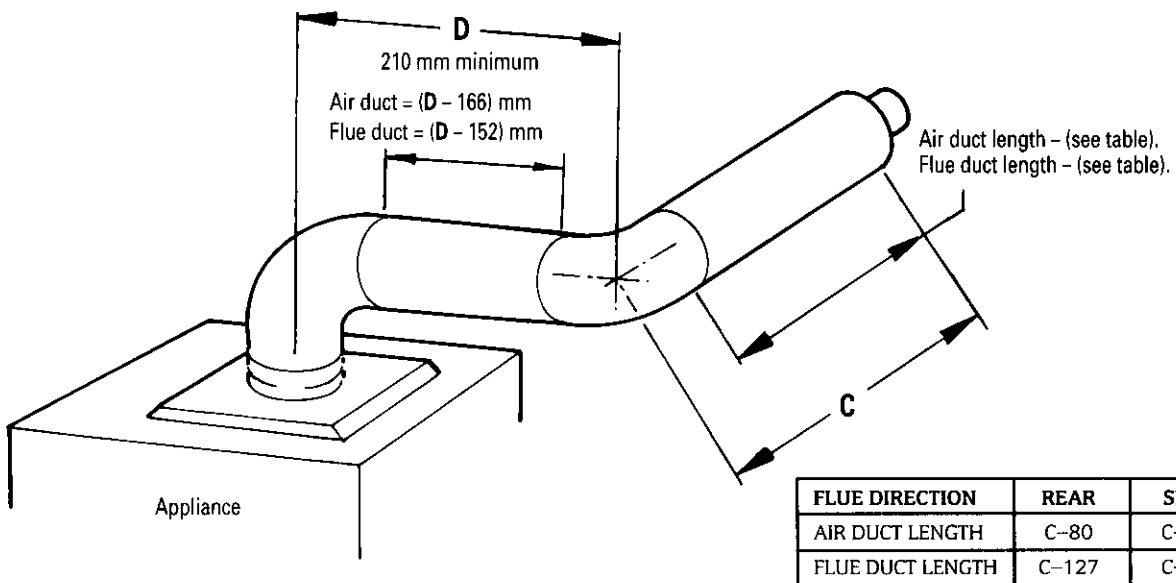

Fig. 27. FLUE OPTION 4. Extension flue horizontal using a second 90° flue bend.

The two flue lengths when added together must not exceed 2300 mm.



FLUE DIRECTION	REAR	SIDE
AIR DUCT LENGTH	C-80	C-58
FLUE DUCT LENGTH	C-127	C-11

Fig. 28. Fitting the flue bends to the intermediate sections of the flue duct.

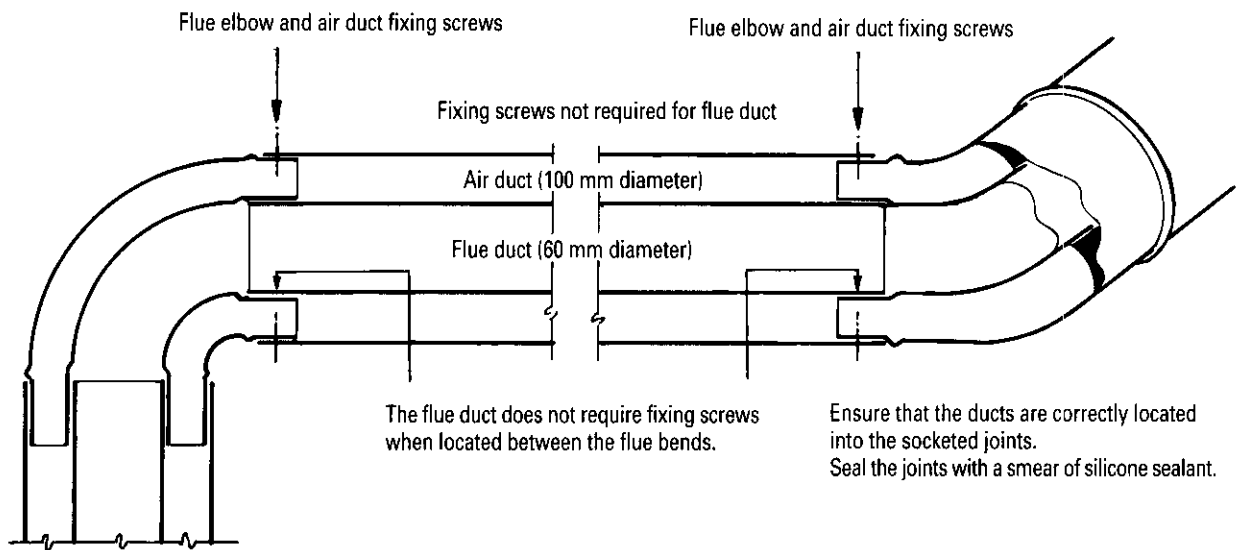

Fig. 29. FLUE OPTION 5. Extension flue upwards and horizontal using a second 90° flue bend.

The three flue lengths added together must not exceed 2300 mm.

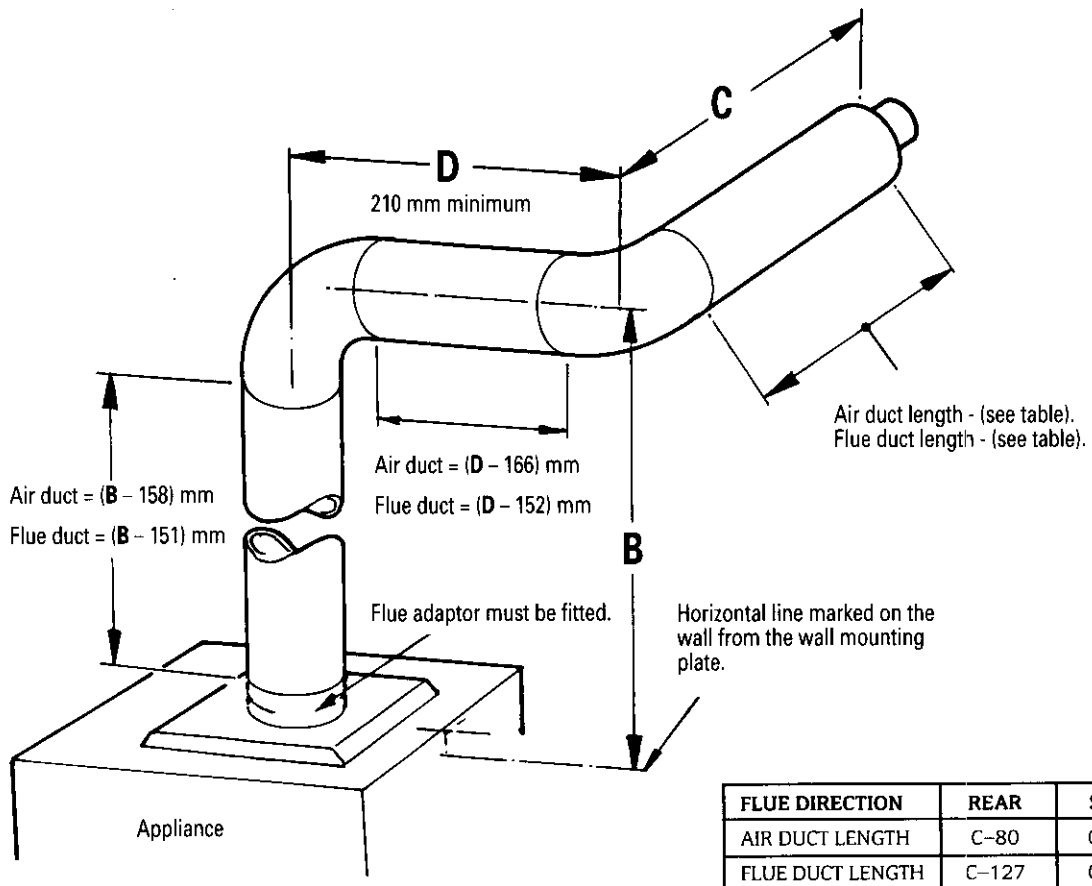
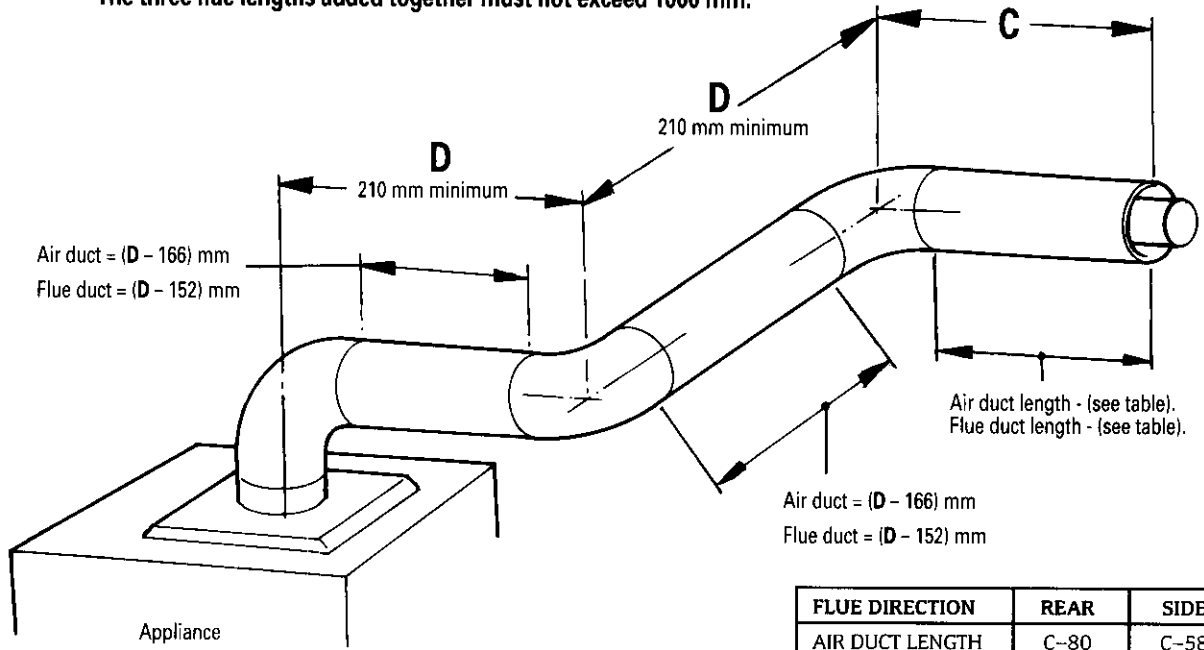

Fig. 30. FLUE OPTION 6. Extension flue horizontal using a second and third 90° flue bend.

The three flue lengths added together must not exceed 1000 mm.



FLUE DIRECTION	REAR	SIDE
AIR DUCT LENGTH	C-80	C-58
FLUE DUCT LENGTH	C-127	C-11

Fig. 31. FLUE OPTION 7. Extension flue upwards and horizontal using a second and third 90° flue bend

The four flue lengths added together must not exceed 1000 mm.

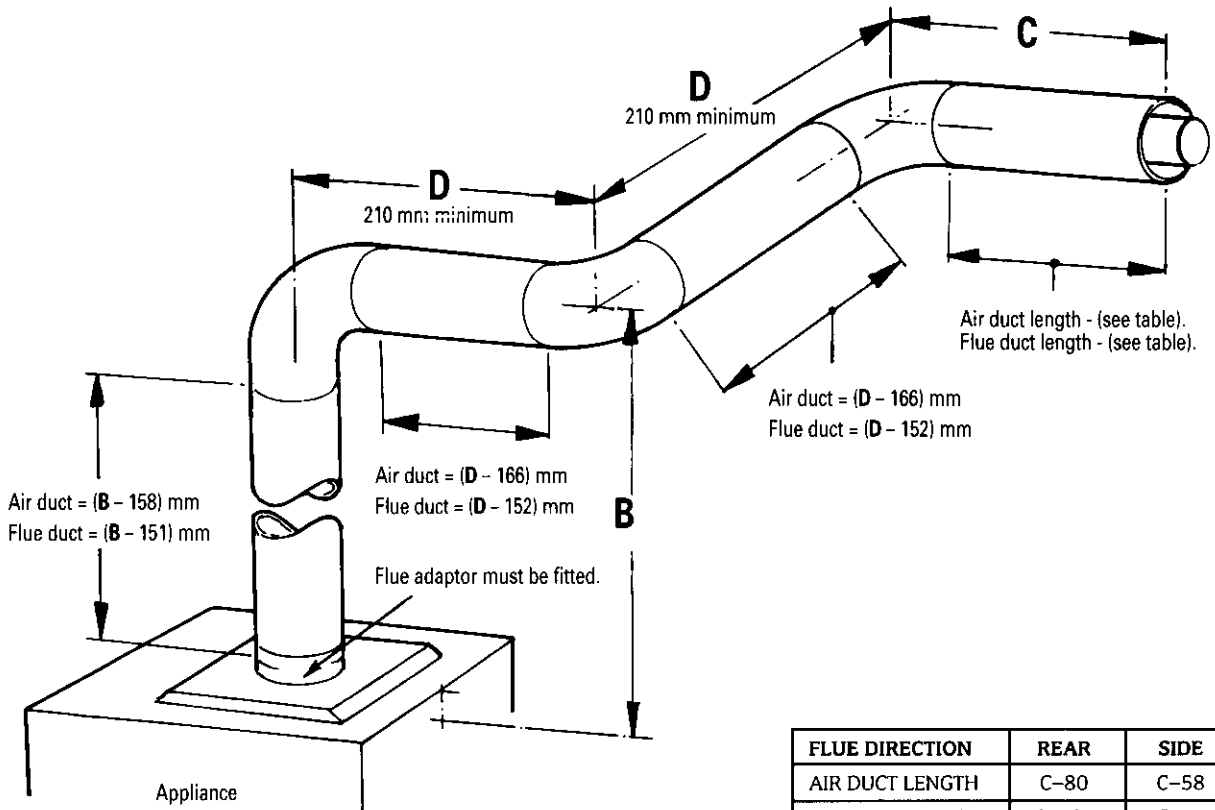

FLUE DIRECTION	REAR	SIDE
AIR DUCT LENGTH	C-80	C-58
FLUE DUCT LENGTH	C-127	C-11

11.7 Final installation

Check that all the water connections and the gas connection have been tightened.

Facia Mounted Programmer (where applicable).

Lower the facia panel as described in Section 15.1(a).

Unplug the Operating Switch at terminal X11 on the main driver board. Unscrew and retain the four nuts and washers securing the switch mounting plate to the facia panel. See Fig.35. Remove the plate. Fit the programmer to the facia panel using the four nuts and washers. Plug the lead into terminal X11 on the main driver board. See Fig.9. The programmer can be set when the electricity supply has been turned off at the commissioning stage.

Connect the mains electricity supply to the appliance and connect any room and/or frost thermostats. Refer to Section 10 and Figs.12 and 13. The leads from the thermostats must pass through the holes provided in the control box at the right hand side and be clamped using the strain relief bushes provided in the pack. Check that the control box can be withdrawn and lowered before fixing any leads outside the appliance. To lower the control box refer to Section 15.1(b).

Refit the control box and facia.

Test the gas supply for soundness as indicated in BS 6891.

If the appliance is not to be commissioned immediately, replace the cabinet front panel.

Check that the gas supply, the electricity supply and the water connections are all turned off.

12. Commissioning

12.1 The appliance is dispatched with the controls set to provide a maximum output for domestic hot water of 28kW (95,500 Btu/h) and satisfy a central heating load of up to 24 kW (82,000 Btu/h).

Domestic Hot Water System

Check that the mains water supply has been fully flushed out at installation.

Central Heating System

Check that the central heating system has been fully flushed out at installation. Refer to BS 7593:1992.

Gas Service

The whole system, including the meter, shall be inspected and tested for soundness and purged as indicated in BS 6891.

12.2 APPLIANCE AND SYSTEM PREPARATION

If the cabinet front panel was replaced on final installation (see Section 11.7) remove the panel before starting the commissioning procedure.

Check that the gas service and the electrical supply to the appliance are turned off. See Fig 3.

Check that all the water connections throughout the system are tight.

Open the system valves at the appliance. See Fig 3. Open all the radiator valves, fill the system and vent each radiator in turn.

The automatic vent (fixed to the flow manifold) will vent the appliance on sealed systems only. See Fig 19. Remove the boiler inner casing cover to check that the cap has been removed. See Figs. 24 and 32. Do not replace the cover until instructed in Section 12.4 – Appliance Operation.

Check that the pressure relief valve operates by turning the knob anti-clockwise until it releases. Water should be expelled from the discharge pipe. See Fig 17. Lower the control box to gain access. Refer to Section 15.1(b).

SEALED SYSTEMS ONLY.

Set the Expansion Vessel Pressure

The charge pressure of the expansion vessel (as supplied) is 0.5 bar, which is equivalent to a static head of 5 meters (17 ft). The charge pressure must not be less than the static head at the point of connection. See Fig 6. A Schraider-type tyre valve is fitted to the expansion vessel to allow the charge pressure to be increased if necessary.

Set the System Pressure

Fill the system until the pressure gauge shows 2.5 bar (37 lb/in²) and check for water soundness. Release water from the system

using the pressure relief valve test knob until the System Design Pressure is obtained up to a maximum of 1.5 bar.

System Design Pressure in bar = Static Head of the System in bar + 0.3

Note: 1 bar is equivalent to 10.2 meters (33.5 ft.) of water.

Set the movable pointer on the pressure gauge to coincide with the indicating pointer – giving a permanent record of the set system pressure.

If the pressure indicated on the pressure gauge is greater than 2.5 bar when operating at the maximum central heating temperature, an extra expansion vessel must be fitted to the system as close to the appliance central heating return connection as possible.

The appliance (as dispatched) can accommodate a system volume of about 104 litres. Refer to BS 7074 Part 1. If the system volume is in excess of that accommodated by the expansion vessel fitted to the appliance then an extra vessel must be fitted as close as possible to the central heating return connection of the appliance.

Any extra vessel fitted must be pressurised to the same figure as the integral vessel. If the expansion vessel fails, the specified replacement must be fitted.

12.3 PROGRAMMER

Any programmer fitted to the appliance should be set up at this stage following the instructions sent with the programmer.

12.4 APPLIANCE OPERATION

Check that the electrical supply to the appliance is off.

Turn the room thermostat (if fitted) to maximum.

Set the Operating Switch (or Programmer) to **OFF**.

In order to thoroughly vent the appliance and system the appliance may be operated **without** the gas turned on as follows:

Lower the control box. See Section 15.1(b) and Fig. 36.

Manually open the diverter valve to the mid-position by sliding the lever the maximum distance to the right. Push the lever upwards and the valve will lodge open in the mid-position. See Fig. 37.

Switch on the electricity supply.

Set the Operating Switch (or Programmer) to **WATER**.

Turn on a hot water tap enough to operate the appliance. The pump and fan will run. A continuous spark will occur at the pilot electrode but the pilot and main burner will not light.

Primary water will now circulate around the appliance and heating circuit.

Allow the appliance to operate in this condition for 10 to 20 minutes. Vent all radiators during this period until air is cleared from the system.

When the system has been vented sufficiently turn off the hot water tap.

Set the Operating Switch (or Programmer) to **HEATING & WATER**.

The diverter valve will open into the central heating position and the manual lever will automatically disengage. Observe the lever to ensure this happens. See Fig. 37.

Replace the control box after observing the lever has disengaged.

Note: Whenever the demand changes from domestic hot water to central heating, the pump, fan and gas valve will de-energise for 8 to 12 seconds while the diverter valve opens. When the diverter valve is fully open to central heating, the pump, fan and gas valve will re-energise.

Set the Operating Switch (or Programmer) to **OFF**.

Switch off the electrical supply.

The appliance and central heating system should now be vented.

Continue the appliance operation:

Disconnect the electrical leads from the solenoid operator on the gas valve (adjacent to the Modureg actuator). See Fig 42. Turn on the gas supply and reconnect the electricity supply.

Set the Operating Switch (or Programmer) to **HEATING & WATER**. A continuous spark will occur until the pilot is alight and sensed by the control circuit. The fan will run but the main burner will not light. Test for gas soundness at the joint between the pilot pipe and the burner with leak detection fluid.

Observe the pilot flame. It should be about 20 mm long and envelope the spark electrode tip. See Figs.34 and 40.

Set the Operating Switch (or Programmer) to **OFF** and disconnect the electrical supply at the mains.

IMPORTANT: Replace the inner casing cover.

Reconnect the electrical connections to the gas valve.

Loosen the burner pressure test point screw and connect a pressure gauge. See Fig 42.

Fig. 32. Appliance components (upper assembly).

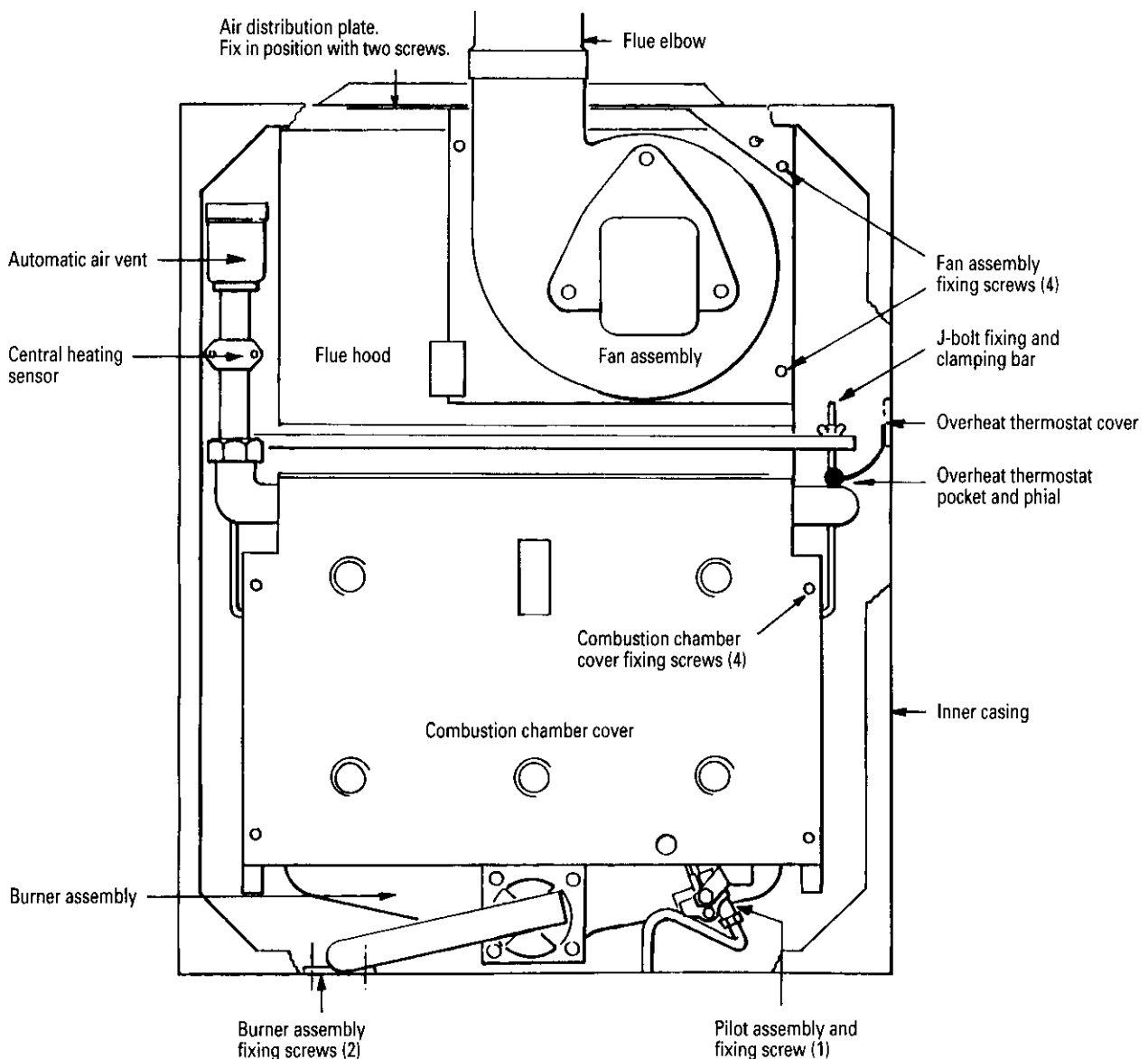

Domestic Hot Water Mode

Set the Operating Switch (or Programmer) to **WATER** and fully open a hot tap.

The boiler should light at a burner pressure of between 14 and 14.5 mbar (5.6–5.8 in.wg). If the burner pressure is low, check that the supply pressure at the gas valve is at least 19 mbar (7.6 in.wg).

The burner pressure is factory set and is NOT adjustable.

If the gas supply pressure is correct but the correct burner pressure is not achieved, contact Worcester Heat Systems Service Department.

If the appliance does not light, check that it is not in the overheat lockout state by pressing the reset button. See Fig 48.

Gradually close the tap and check that the burner pressure drops. Fully open the tap and check that the burner pressure rises.

Shut the tap and check that the burner goes off. The pump will continue running until the appliance has cooled to a preset temperature.

Set the Operating Switch (or Programmer) to **OFF**.

Central Heating Mode

Check that all the radiator valves are open.

Set the room thermostat (if fitted) to maximum and the Central Heating Temperature Control Knob on the fascia panel to maximum.

Sealed Systems Only

Check that the system is pressurised and set to the required pressure as indicated on the gauge.

Set the Operating Switch (or Programmer) to **HEATING & WATER**.

The appliance will light and slowly modulate its output over a period of a few minutes from 10.5 kW (35,900 Btu/h) to the output required by the central heating system up to its maximum of 24 kW (82,000 Btu/h).

The gas pressure is NOT adjustable.

Check the system to ensure that all the radiators are heating up evenly.

Shut down all the radiators but one and observe the burner pressure fall. Open all of the radiator valves and check that the burner pressure rises.

Balance the system so that the required temperature difference across the heating flow and return pipes is obtained. See Section 3, Table 1.

Adjust the by-pass valve until the same temperature difference is obtained. See Figs.15 and 36. This should be carried out with only a single radiator operating. If thermostatic radiator valves are fitted, then one radiator should be left uncontrolled. The by-pass valve should never be fully closed.

Set the room thermostat to minimum and check that the burner goes out.

Reset the room thermostat to maximum and the burner will re-light and follow the normal operating procedure.

Fig. 33. Burner flange

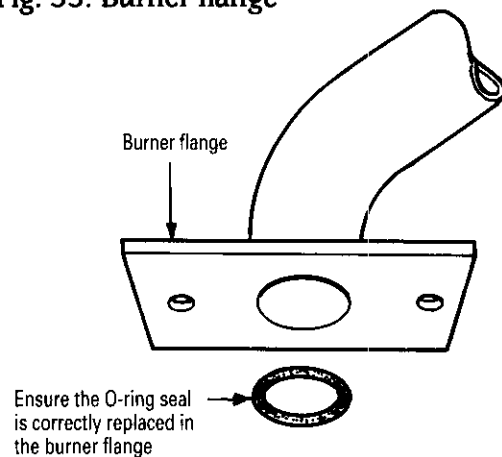
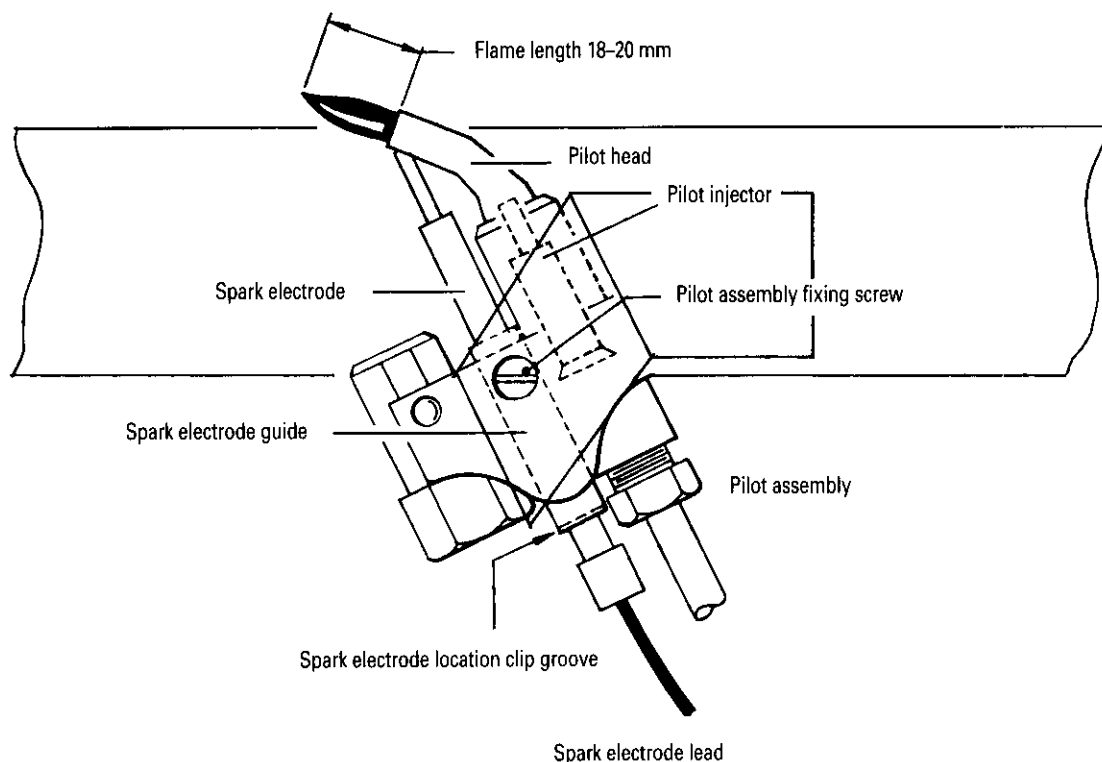

Fig. 34. Burner pilot assembly



Check for proper ignition of the burner after a break in the gas supply. Turn off the gas service cock and wait 60 seconds. The main burner and pilot will go out but sparking from the electrode will continue. Carefully open the gas service cock and observe the burner relight and follow the normal sequence of operation.

Put the Operating switch (or Programmer) to **OFF**.

Switch off the gas service cock and the electrical supply to the appliance.

Drain the system while the appliance is still hot.

Refill, vent and re-pressurise sealed systems as described previously.

Domestic Hot Water and Central Heating Mode

Turn on the electricity supply to the appliance and open the gas supply cock at the appliance.

Set the Operating Switch (or Programmer) to **HEATING & WATER**. If a programmer is fitted, set the domestic hot water to **Continuous** or **24hrs** and the central heating to **ON**. The burner will light and heat will pass into the system.

Turn on a hot water tap and check that fully heated hot water is discharged from the tap.

Shut the tap. The burner will go off and the appliance will return to the central heating mode and automatically balance with the

system requirements.

Set the Operating Switch (or Programmer) to **OFF** and the burner will go out.

12.5 COMPLETION OF COMMISSIONING

Disconnect the pressure gauge and tighten the test point screw.

Restart the appliance and check for gas soundness around the test point screw.

Refit the cabinet front panel.

If the appliance is being passed over to the user immediately, refer to Section 13—Users Instructions and set the controls to the user's requirements.

If the appliance is to be left inoperative, check that the Operating Switch is set to **OFF**. Turn the gas service cock to off and switch off the electricity supply.

If there is any possibility of the appliance and system being left inoperative during frosty conditions then drain the appliance and system.

For short inoperative periods, leave the appliance under the control of the built-in frost thermostat and the remote frost thermostat (if fitted) or leave operating continuously under the control of a room thermostat set at 6°C.

13. Instructions To The User

13.1 Tell the user how to operate the appliance and hand over the Operating Instructions leaflet.

13.2 Tell the user the appliance has a built-in frost thermostat and will operate during periods of low temperature providing the gas and electricity supplies are switched on, even though the appliance controls may be switched off.

Also tell the user that if the appliance is not to be used for long

periods during frosty weather, the system must be drained and the gas and electricity supplies turned off.

13.3 Tell the user the Sealed System set pressure.

13.4 Tell the user of the importance of regular servicing. Worcester Heat Systems Ltd. offer a comprehensive maintenance contract.

13.5 Set the system controls to the users requirements.

13.6 If an external programmer with a programmable domestic hot water facility has been fitted, it is suggested that this be set to **Continuous** or the equivalent.

Fig. 35. Facia (rear view in lowered position).

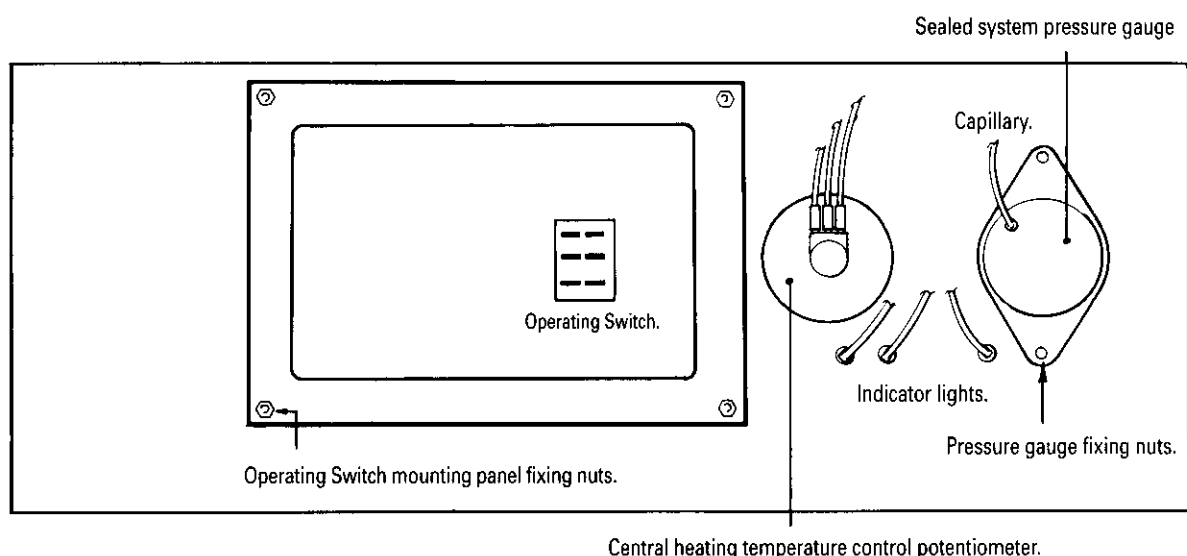

Fig. 36. Water flow control components and control box in service position.

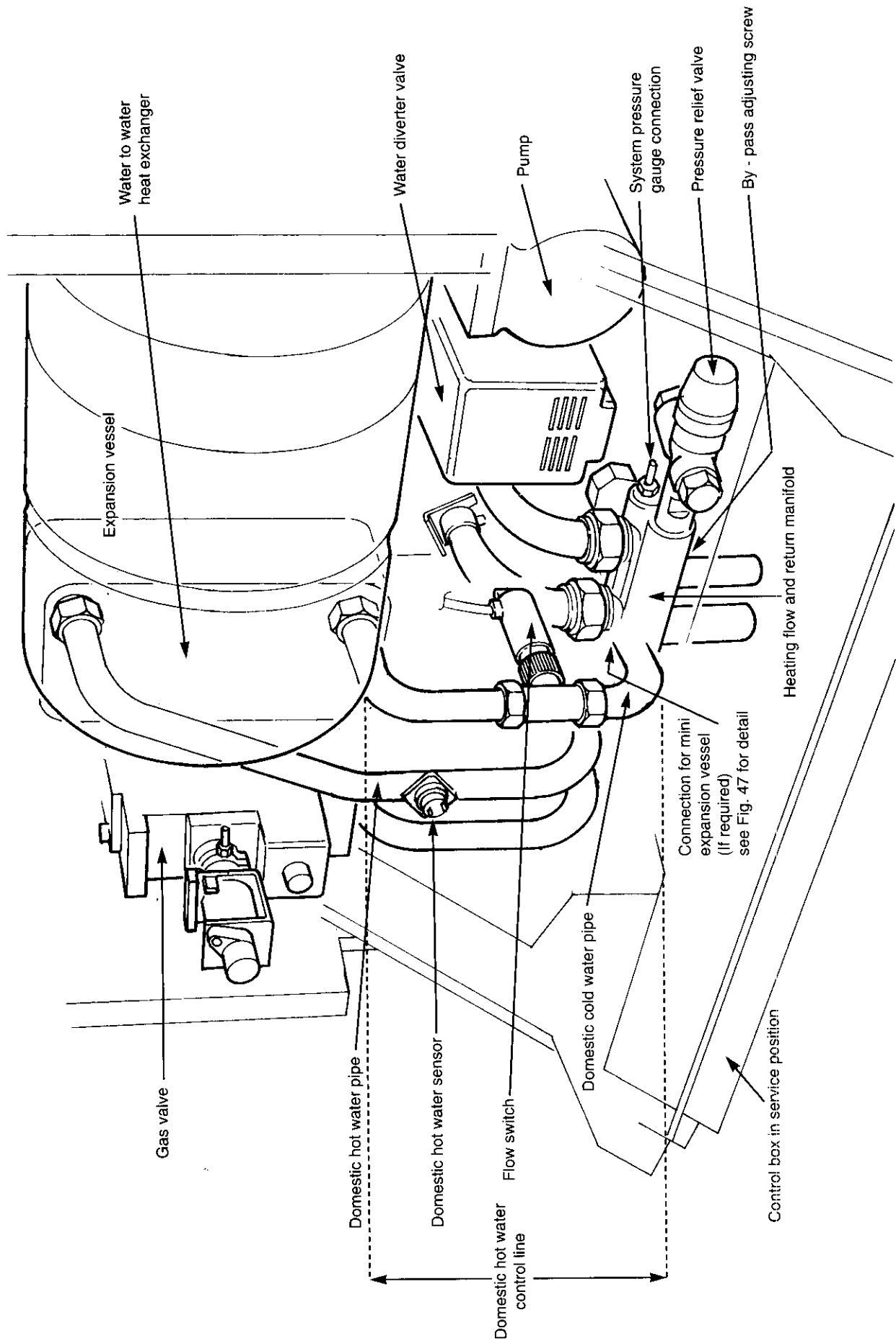
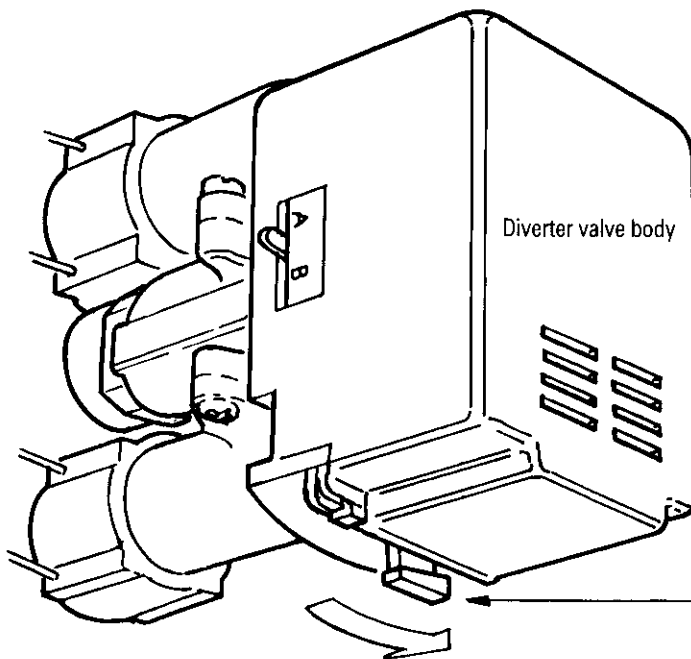

Fig. 37. Manually opening the diverter valve.



Note. Orientation of diverter valve.
The manually operated lever must be located on underside.

To manually open the diverter valve, slide the lever to the right and hold open.

Push the lever up and the valve will stay open in the mid-position.

Ensure when the lever is released, it spring returns to the closed position.

VIEW ON UNDERSIDE OF THE DIVERTER VALVE.

14. Inspection and Servicing

To ensure continued efficient operation of the appliance, it must be checked and serviced as necessary at regular intervals. The frequency of servicing will depend upon the particular installation conditions and usage, but once a year should generally be adequate. The extent of the service required by the appliance is determined by the operating condition of the appliance when tested by fully qualified engineers.

It is the law that any service work must be carried out by competent engineers such as British Gas or Corgi registered personnel.

14.1 PRE-SERVICE INSPECTION

Check that the flue terminal and the terminal guard (if fitted) are clear.

If the appliance is in a compartment, check that the ventilation openings in the compartment door or walls are clear. See Section 6—Air Supply.

Check the system and remake any joints or fittings which show signs of leakage. Refill, vent and re-pressurise sealed systems as described in Section 12—Commissioning.

Operate the appliance and the system taking note of any faults.

Important Disconnect the electrical supply at the mains and turn off the gas supply at the gas service cock on the appliance before servicing. See Fig 3.

After completing the service, always test for gas soundness as indicated in BS 6891.

14.2 DISMANTLE THE APPLIANCE

To carry out a full and comprehensive service of the appliance remove the following parts to gain access to the components which need to be checked or serviced.

(a) Cabinet Front Panel. Pull forward at the bottom and lift off the top supports. See Fig.2.

(b) Inner Casing Cover. Remove the cabinet front panel. Unscrew the five screws securing the cover to the casing and lift off. See Fig.24.

(c) Air Distribution Plate. Unscrew the two screws securing the air distribution plate to the inner casing. Ease the air distribution plate clear of the inner casing. See Fig.32.

(d) Fan. Remove the inner casing cover and air distribution plate. Ease the two electrical connections from the fan motor and the flexible suction pipe from the fan housing. Unscrew the four screws securing the fan assembly to the flue hood. Ease the fan assembly out of the flue elbow by lowering. Remove the fan assembly. See Fig.32.

(e) Flue Hood Assembly. Remove the air distribution plate and fan assembly. Unscrew the two wing nuts and washers (one from each side of the flue hood assembly) and remove the 'J' bolts and clamping bar. Ease the flue hood off the heat exchanger and clear of the inner casing. See Fig.32.

(f) Combustion Chamber Cover. Remove the the inner casing cover. Unscrew the four screws securing the combustion chamber cover and remove the cover. See Fig.32.

(g) Burner Assembly. Remove the combustion chamber cover. Remove one screw securing the pilot assembly to the burner. See Fig.32. Unscrew the two screws securing the burner assembly to the inner casing. Lift the burner and ease the pilot assembly out of the pilot bracket. Remove the burner assembly by easing forward and upward until clear of the pilot assembly and the location at the rear of the inner casing.

The burner flange has an O-ring which seals with the gas manifold flange. Ensure the O-ring is retained. See Fig.33.

(h) Pilot Assembly. Remove the burner assembly. Unscrew the pilot pipe union nut and remove the pipe from the pilot assembly. Remove the pilot injector from the assembly. See Fig.34.

14.3 SERVICING OF COMPONENTS

Clean the Fan. Any dust or fluff should be removed with a soft brush or by blowing. Take care not to distort the sensing tube.

Clean the Burner. Brush the blade tops and mixing tube with a soft brush and check that all the flame ports are clear. Remove any blockages with a non-metallic brush. Inspect the injector and clean with a soft brush. Replace the injector if it appears damaged. Do not use a wire brush or anything likely to cause damage.

Clean the Pilot Burner Assembly. Brush with a soft brush. Clean the pilot injector by rinsing it in warm water. Replace the electrode if it appears damaged.

Clean the Gas to Water Heat Exchanger. Cover the burner manifold with a cloth. Clean the heat exchanger using a soft brush. Remove the deposits from the bottom of the combustion chamber. Do not distort any of the blades.

Combustion Chamber Insulation. Examine and replace any pads that are damaged. See Section 15.3 (7).

Controls. Remove any dust or deposits using a soft brush. Take care not to mishandle any component connections.

After servicing, reassemble the appliance in the reverse order. Check that all components are in place and correctly fixed. See Fig.32. Leave the cabinet front panel to be fitted after checking the operation of the appliance.

14.4 TEST THE APPLIANCE

On completion of the service and reassembly of the appliance, check for gas soundness and the correct operation of the appliance as described in Section 12–Commissioning.

Refit the cabinet front panel and reset the controls to the users requirements.

15. Replacement of Parts

IMPORTANT. Switch off the electricity and gas supplies before replacing any components. After the replacement of any components, check for gas soundness (where relevant) and carry out functional checks as described in Section 14.

15.1 COMPONENT ACCESS.

To replace components it is necessary to remove one or more sections of the cabinet and cover plates within the appliance as described in Section 14.2. The fascia panel and control box may also need to be lowered as described following:

(a) Facia Panel. Check that the electricity supply to the appliance is turned off.

Remove the cabinet front panel as described in Section 14.2.(a).

Remove the three screws which hold the facia assembly in position. Lower the fascia assembly. The assembly can be unhooked from its supports. Do not allow it to hang unsupported. See Fig.35.

(b) Control Box. Unscrew the two fixing screws at each end of the control box. Pull the complete assembly forward and lower into the service position. The complete assembly can be unhooked from its supports. Do not allow it to hang unsupported. See Fig.36.

IMPORTANT: The following components are secured to the appliance with clips, screws or O-ring seals to ensure the joints are water tight. See Fig. 36.

- Expansion vessel
- Central heating pump.
- Water diverter valve
- Water to Water heat exchanger
- Gas to Water heat exchanger

When replacing these components the connections must be fully entered so that the clips can pass completely into the locating groove. The clips must not be forced into place.

Any O-ring which shows sign of damage must be replaced. The O-rings can be lubricated with a suitable lubricant (silicon based grease or glycerin) which is non-reactive with the ethylene-propylene nitrile O-rings.

Comprehensive gasket/O-ring packs are available for the gas and water connections on the appliance. See Section 18.

15.2 DRAINING THE APPLIANCE.

Check that the electricity supply to the appliance is turned off. Before removing any component holding water, it is important that as much water as possible is removed from the appliance.

Remove the casing bottom panel which is secured to the control box side supports by one screw at each end of the panel. See Fig.18. Pull the control box forward. Refer to Section 15.1 (b).

(a) Appliance Central Heating Circuit. Turn off the central heating flow and return valves at the appliance using an adjustable spanner or a screwdriver. See Fig.14. Fit a tube to the drain tap and open the tap about one turn. See Figs.17 and 36. Slide the lever on the underside of the water diverter valve to the manually open position. See Fig. 37. This action should assist in draining the appliance. Close the drain tap when the flow has stopped.

Note: Some water will remain in the water to water heat exchanger expansion vessel, pump, water diverter valve and Gas to Water heat exchanger. Extra care must be taken when removing these components.

(b) Appliance Domestic Hot Water Circuit. Turn off the mains water supply valve at the appliance using a flat blade screwdriver. See Fig.14. A quantity of water will remain in the Water to Water heat exchanger. Extra care must be taken when removing this component.

15.3 COMPONENT REPLACEMENT

1. Automatic Air Vent. (Sealed Systems only). See Fig.19.

Check that the electricity supply to the appliance is turned off.

Remove the inner casing cover as described in Section 14.2(b).

Drain the central heating circuit as described in Section 15.2(a).

Unscrew the assembly and fit the replacement assembly.

Open the valves and fill and re-pressurise the system as described in Section 12.2.

2. Air Flow Pressure Switch. See Fig.48.

Check that the electricity supply to the appliance is turned off.

Remove the cabinet front panel as described in Section 14.2(a).

Lower the facia panel as described in Section 15.1(a).

Carefully pull off the suction tubes and the electrical connections from the switch.

Unscrew the two fixing screws from the right hand side of the air pressure switch and remove the switch from the control box.

Fit the replacement switch in reverse order. Ensure the electrical connections are made to the correct terminals (see Fig.9) and the suction tubes are fitted to the correct connections on the switch. Tube marked positive (+) to the bottom connection and the tube marked negative (-) to the top connection.

3. Fan. See Fig.32.

Check that the electricity supply to the appliance is turned off.

Remove the inner casing cover as described in Section 14.2(b).

Remove the fan assembly as described in Section 14.2(d).

Fit a replacement fan in the reverse order.

4. Overheat Thermostat. See Figs.32 and 48.

Check that the electricity supply to the appliance is turned off.
Remove the inner casing cover as described in Section 14.2(b).
Unscrew the three screws securing the right hand side panel. Ease the panel forwards and at the same time lift it off the top front location.

Lower the facia panel as described in Section 15.1(a).

Unscrew the two screws securing the sealing cover to the inner casing and remove the cover. Remove the clip and pull the phial from the pocket on the Gas to Water heat exchanger. Carefully feed the capillary tube and phial through the hole in the inner casing. Pull off the two electrical connections to the overheat thermostat. Remove the central clamping nut. Withdraw the thermostat and thread the capillary through the hole in the control box.

Fit a new thermostat in the reverse order and ensure that the sealing cover is replaced and seals the inner casing. Also ensure that the electrical connections are made to the thermostat terminals (polarity is not important) and heat sink compound is applied to the thermostat probe.

5. Gas to Water Heat Exchanger. See Figs.32 and 38

Check that the electricity supply to the appliance is turned off.

Drain the central heating circuit as described in Section 15.2(a).

Remove the inner casing cover, air distribution plate, fan, flue hood assembly, combustion chamber cover, and overheat thermostat probe as described in Sections 14.2(b), 14.2(c), 14.2(d), 14.2(e), 14.2(f), and 15.3(4). Ease off the two electrical connections from the central heating sensor.

Unscrew the union connection at the front of the heat exchanger and pull out the securing clip from the rear of the flow pipe. Remove the flow pipe and fibre sealing washer. See Fig.38.

Pull out the securing clip from the rear of the heat exchanger and remove the heat exchanger. See Fig.38.

WARNING: There will be a small quantity of water remaining in the heat exchanger.

Fit the new heat exchanger and flow pipe in the reverse order using new O-rings and fibre sealing washer.

Take care to ensure the securing clips are properly entered.

Reassemble the appliance in reverse order.

Ensure a layer of heat sink compound is on the overheat thermostat probe.

Open the valves and fill and re-pressurise the system as described in Section 12.2.

6. Central Heating Sensor. See Fig.32 and 38.

Check that the electricity supply to the appliance is turned off.

Remove the inner casing cover as described in Section 14.2(b).

Carefully pull off the two leads to the sensor. Remove the two M3 screws securing the sensor to the mounting plate on the flow pipe above the Gas to Water heat exchanger.

Fit the replacement sensor with a layer of heat sink compound between the faces. Refit the leads. Polarity is not important.

7. Combustion Chamber Insulation. See Fig.39.

Check that the electricity supply to the appliance is turned off.

Drain the heating circuit as described in Section 15.2(a).

Remove the inner casing cover, air distribution plate, fan, flue hood assembly, and Gas to Water heat exchanger as described in Sections 14.2(b, c, d and e) and 15.3(5).

Remove the fibre insulation pads from the combustion chamber side, rear, and front sections.

Fit the replacement pads in the reverse order taking care not to damage them.

Open the valves and fill and re-pressurise the system as described in Section 12.2

8. Main Burner. See Figs.32 and 33.

Check that the electricity supply to the appliance is turned off.

Remove the inner casing cover and burner assembly as described in Sections 14.2(b) and 14.2.(g).

Fit a replacement burner in the reverse order. Replace the O-ring seal if there is any sign of damage or deterioration.

Fig. 38. Gas to Water heat exchanger clips and fixings.

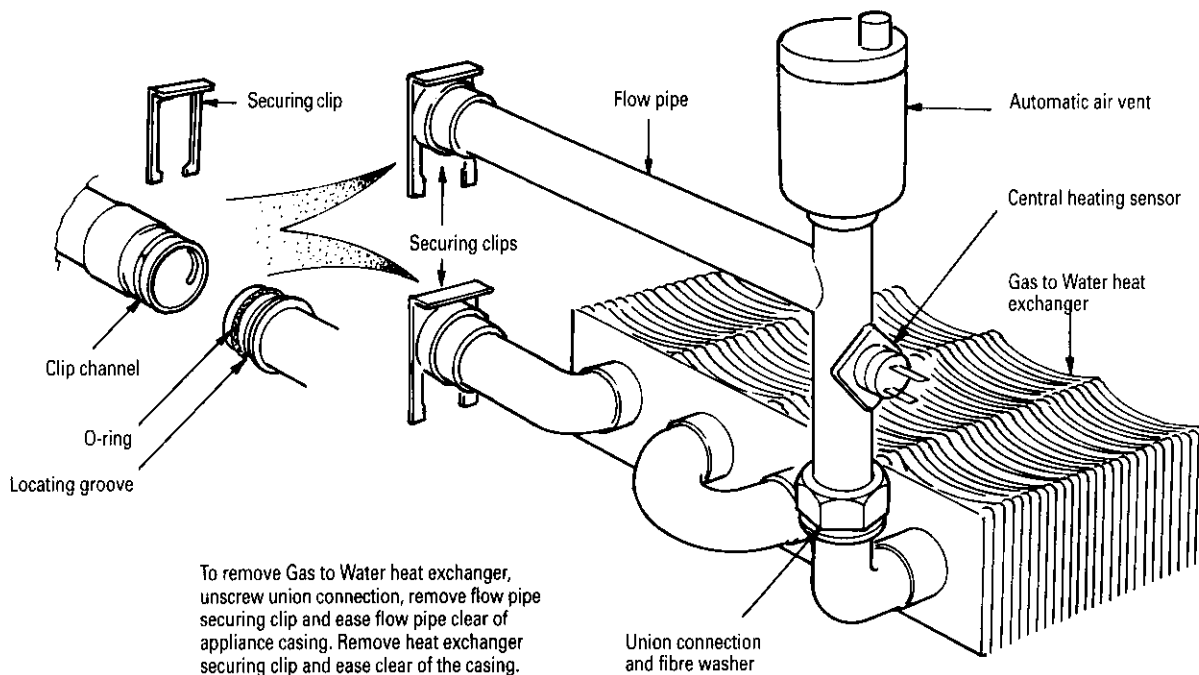

Fig. 39. Combustion chamber insulation.

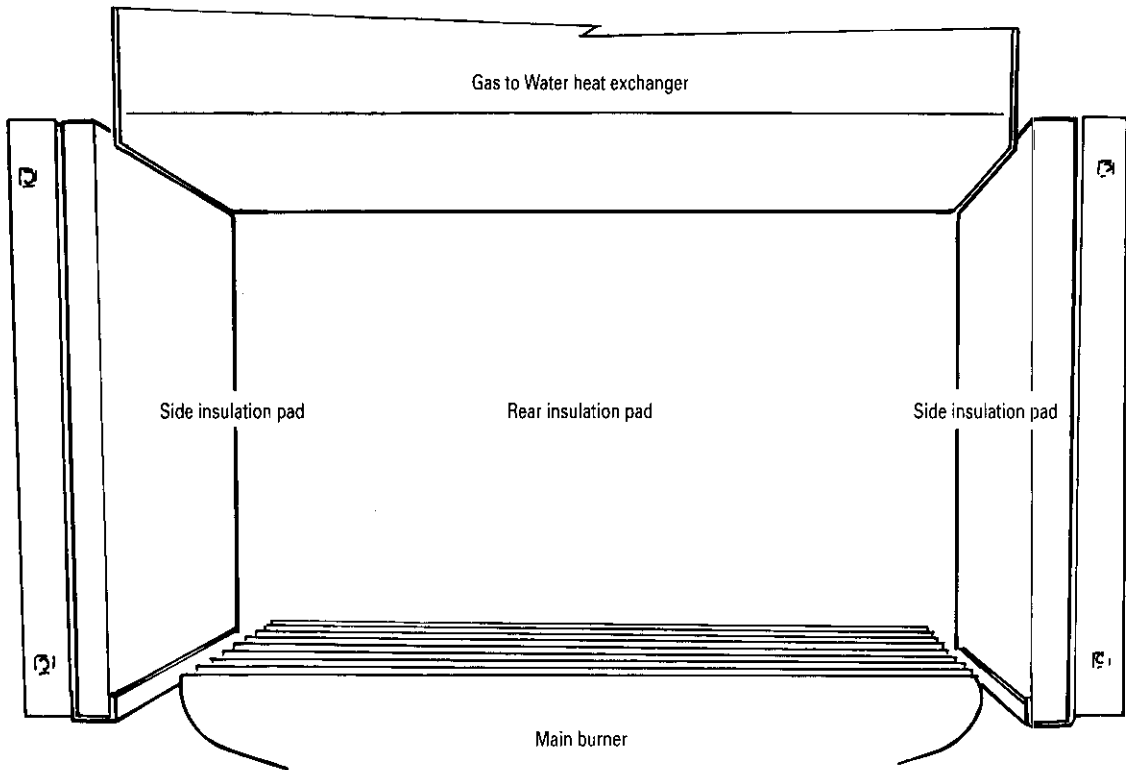
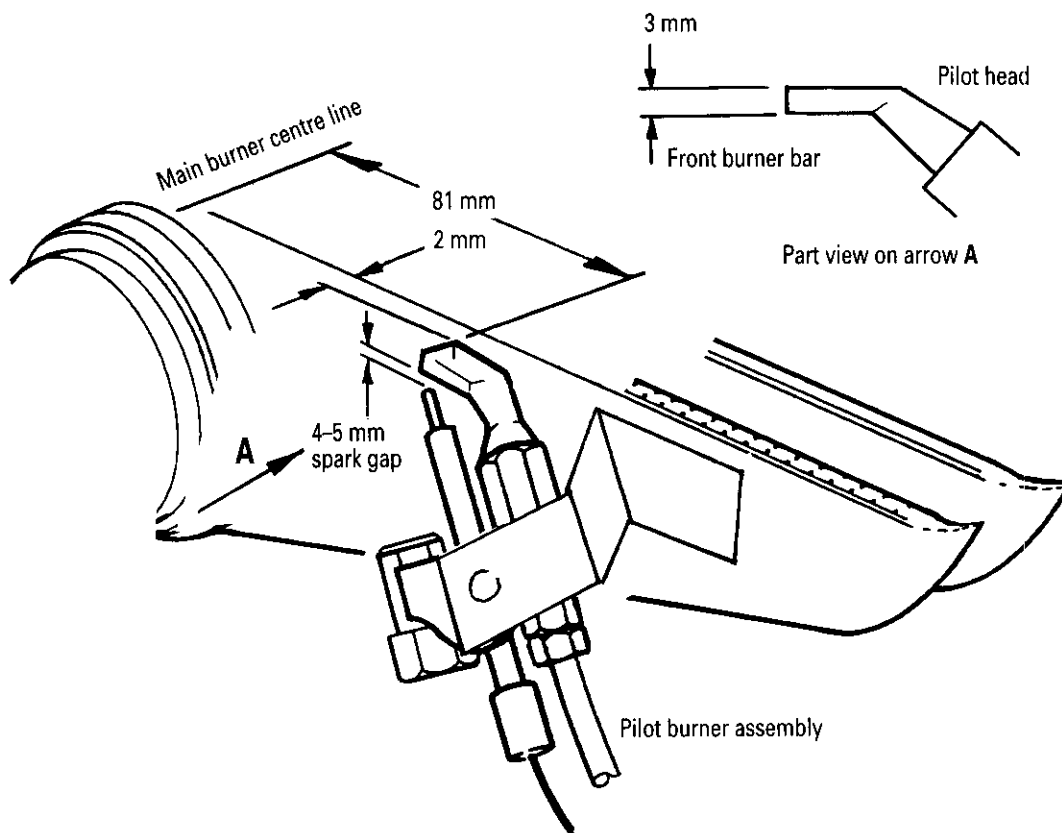

Fig. 40. Pilot burner setting.



9. Pilot Burner. See Figs.34 and 40.

Remove the main burner as described in Section 15.3(8).

Support the pilot burner and unscrew the nut securing the pilot pipe. Remove the spark electrode lead and pull the spark electrode out of the clip.

Fit a replacement burner in the reverse order. Check the pilot burner settings and spark electrode gap are as shown in Fig.40 and Section 15. .

10. Main Burner Injector. See Fig.41.

Remove the main burner as described in Section 15.3(8).

Unscrew the brass injector fitted in the burner manifold. Fit a replacement injector in the reverse order.

11. Pilot Injector. See Fig.34.

Check that the electricity supply to the appliance is turned off.

Remove the inner casing cover, burner assembly and pilot assembly as described in Sections 14.2(b, g and h)

Remove the injector which is a push fit inside the pilot bracket.

Fit the replacement injector in the reverse order.

12. Spark Electrode. See Figs.34 and 40.

Check that the electricity supply to the appliance is turned off.

Remove the inner casing cover, burner assembly and pilot assembly as described in Sections 14.2(b, g and h).

Pull the spark electrode out of the clip and remove from the pilot bracket.

Fit the replacement electrode in the reverse order. Check the pilot burner settings and that the spark electrode gap are as shown in Fig.40 and Section 15.

13. Spark Electrode lead. See Figs.34 and 48.

Check that the electricity supply to the appliance is turned off.

Remove the inner casing cover as described in Section 14.2(b).

Remove the pilot tube supply sealing cover from the underside of the inner casing and lower the facia panel as described in Section 15.1(a). Carefully pull one end of the lead from the electrode and ease the other end off the tag on the ignition control board. Remove the cable from the appliance.

Fit a replacement lead in the reverse order ensuring the boiler casing is sealed correctly.

14. Gas Valve. See Figs.36 and 42.

Check that the electricity and gas supplies to the appliance are turned off.

Remove the inner casing cover and burner assembly as described in Section 14.2(b and g). Hang the control box assembly in the servicing position as described in Section 15.1(b).

Fig. 41. Main burner injector.

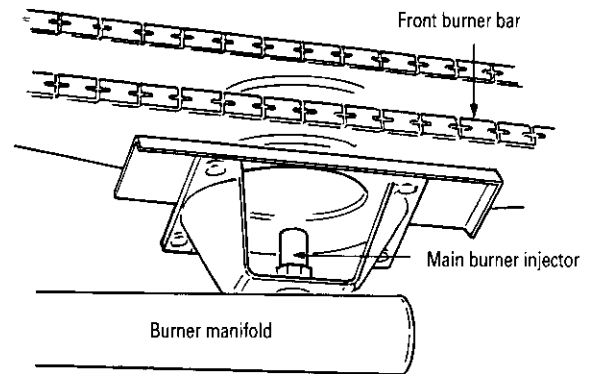

Pull off the pressure compensating tube. Disconnect the pilot tube. Unscrew the retaining screw and remove the black plastic plug from the main solenoid connections. Carefully pull off the two yellow wires from their terminals. Remove the screw and pull off the black cover from the pilot solenoid connections. Unscrew the gas union at the manifold connection. Support the gas valve and remove the four screws securing the flange to the underside of the inner casing. Remove the gas valve and pipework clear of the appliance. Remove the four screws securing the gas inlet pipe and four screws securing the gas manifold to the gas valve.

Reassemble the gas inlet pipe and gas manifold to the new gas valve. Ensure the sealing washers between the gas valve inlet flange and the manifold flange are replaced correctly.

Reassemble the gas valve and pipework in the reverse order

Turn on the gas supply and check for soundness.

15. Pilot Filter

If problems are experienced with the pilot filter, fit a replacement gas valve as described in Section 15.3(14).

16. Domestic Hot Water Sensor. See Fig.36.

Check that the electricity supply to the appliance is turned off.

Hang the control box assembly in the servicing position as described in Section 15.1(b).

Fig. 42. Gas valve.

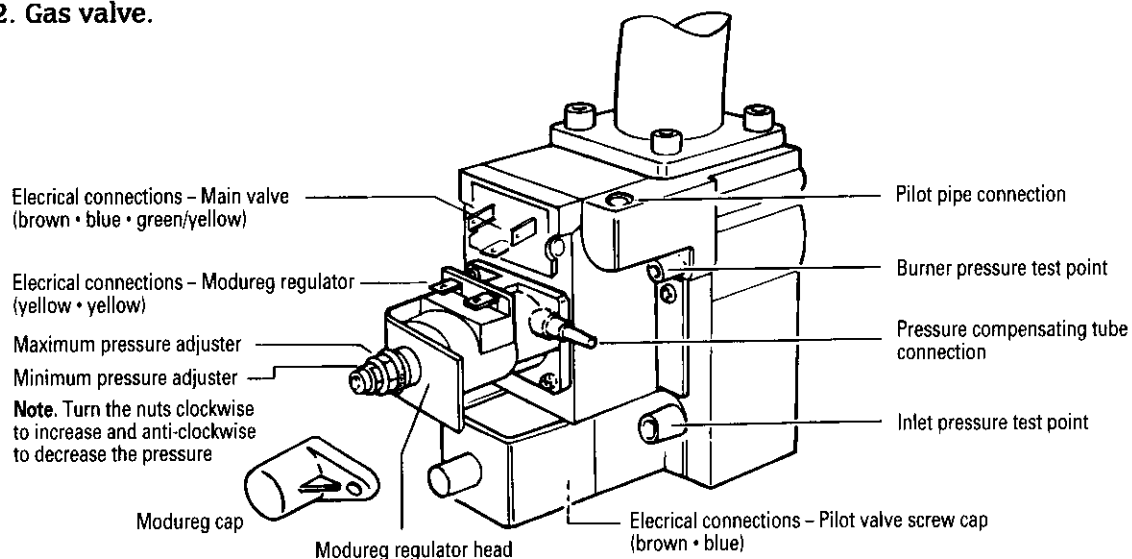
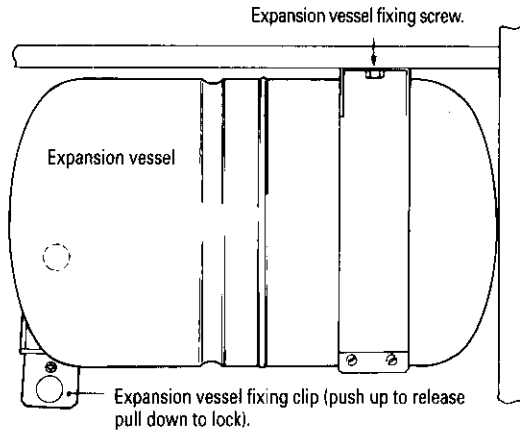

Fig. 43. Expansion vessel.



Carefully pull off the two electrical leads from the sensor and remove the two M3 screws holding the sensor to the pipe.

Fit the replacement sensor in the reverse order ensuring a layer of heat sink compound is between the faces. Reconnect the two electrical leads. Polarity is not important.

17. Expansion Vessel. See Figs.36 and 43.

Check that the electricity supply to the appliance is turned off.

Lower the control box. See Section 15.1(b). Drain the central heating circuit as described in Section 15.2(a). Unscrew the expansion vessel securing screw and support the vessel. Push up the securing clip at the rear of the vessel to release the connection. Remove the vessel. Take care when removing the vessel as a small quantity of water will remain inside the vessel and back panel.

Set the clip in its open position and fit the new vessel in the reverse order using a new O-ring. Lubricating the 'O'ring with soap solution will help.

Open the valves and fill and re-pressurise the system as described in Section 12.2.

18. Circulating Pump. See Figs.36 and 45.

Check that the electricity supply to the appliance is turned off.

Drain the central heating circuit as described in Section 15.2(a).

Hang the control box assembly in the servicing position as described in Section 15.1(b). Remove the expansion vessel as described in Section 15.3(17). Remove the pump cover and disconnect the electrical connections. See Fig.45. Withdraw the two securing clips from the pump body. See Fig.45. Remove the pump.

Warning: There will be a small quantity of water remaining in the pump and back panel.

Fit a new O-ring.

Fit the new pump in the reverse order taking care to ensure that the securing clips are properly entered into the slots and not scoring the O-rings on entry. A small smear of lubricant on the O-ring will help the reassembly. Check that the pump is set to maximum. The pump head is a Grundfos 15/60. A replacement head may be transferred to the special body. Take care not to mark the mating surfaces.

Replace the expansion vessel.

Open the valves and fill and re-pressurise the system as described in Section 12.2.

19. Water Diverter Valve. See Figs.36, 37, and 44.

Check that the electricity supply to the appliance is turned off.

Drain the central heating circuit as described in Section 15.2(a).

Lower the fascia panel as described in Section 15.1(a). Unplug connection X6 (marked DIV VALVE) at the main driver board and remove the electrical cable and plug from the rear of the control box.

Lower the control box as described in Section 15.1(b). See Fig.36.

Remove the expansion vessel as described in Section 15.3(17).

Withdraw the two securing clips from the valve body See Fig.44. Remove the valve.

Fig. 44. Water diverter valve (rear view).

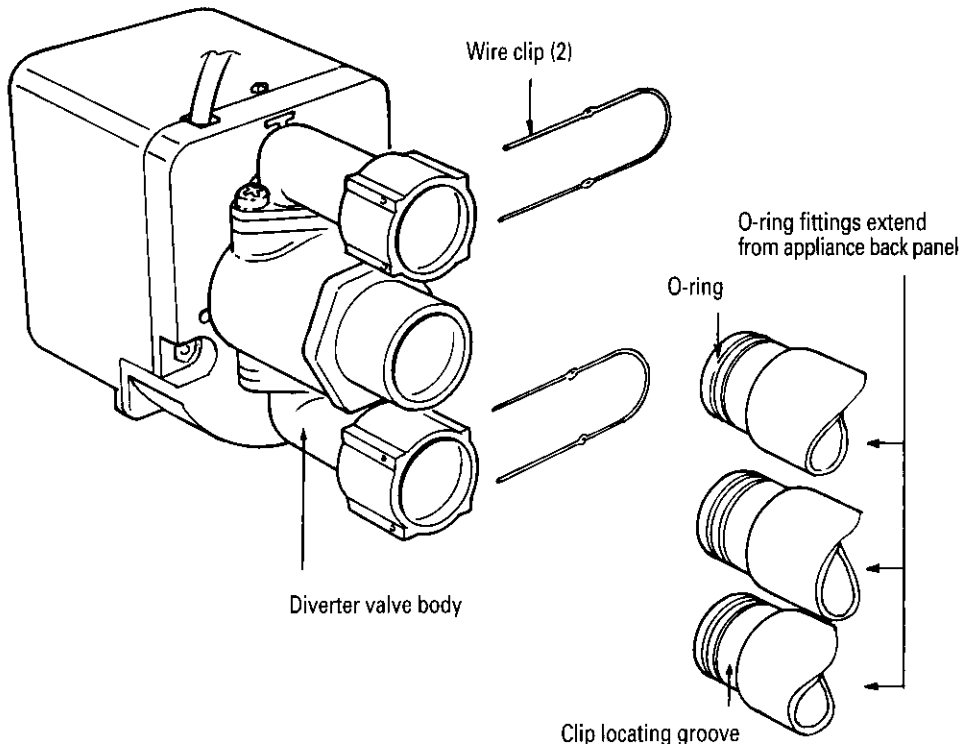
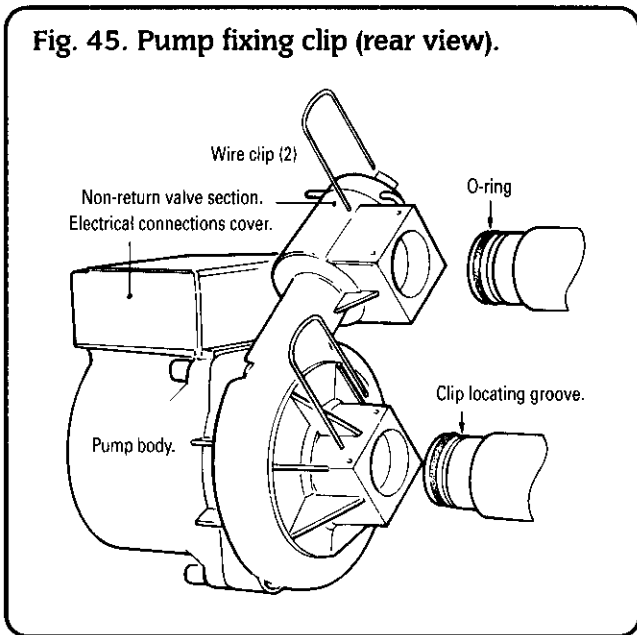

Fig. 45. Pump fixing clip (rear view).



Warning: There will be a small quantity of water remaining in the valve and back panel.

Fit new O-rings.

Fit the new valve in the reverse order. Check the valve orientation. See Fig.37. Ensure that the securing clips are properly entered into the slots and not scoring the O-rings on entry. A small smear of lubricant on each O-ring will help the reassembly.

Refit the electrical cable in the reverse order and ensure the plug is fitted correctly to the main driver board.

Note. The manual operating lever must be positioned on the underside of the valve. See Fig. 37.

Refit the expansion vessel.

Open the valves and fill and repressurise the system as described in Section 12.2.

20. Pressure Relief Valve. See Figs. 17 and 36.

Check that the electricity supply to the appliance is turned off.

Drain the central heating circuit as described in Section 15.2(a).

Hang the control box assembly in the servicing position as described in Section 15.1(b).

Undo the drain pipe connection and unscrew the pressure relief valve taking care not to distort the pipework.

Fit a replacement valve using suitable thread sealing compound.

Reconnect the drain pipe.

Open the valves and fill and repressurise the system as described in Section 12.2.

21. Water to Water Heat Exchanger. See Figs. 36, 46 and 47.

Check that the electricity supply to the appliance is turned off.

Drain the central heating and domestic hot water circuits as described in Section 15.2(a and b). Lower the control box as described in Section 15.1(b). Remove the expansion vessel as described in Section 15.3(17). Remove the leads from the hot water sensor. Unscrew the cold water inlet and domestic hot water outlet union connections at the manifold and allow the heat exchanger to drain. Unscrew the top union connection and remove the hot water pipe.

Unscrew the top union connection on the flow switch, See Fig. 47. Lay the flow switch and lower pipework to one side. Unscrew the bottom union connection on the heat exchanger and remove the cold water inlet pipe. See Fig. 46.

Using an open ended 8mm spanner, unscrew two full turns but do not remove the left-hand fixing screw located behind the heat exchanger. Remove the top right-hand fixing clip located behind the heat exchanger.

Ease the Water to Water heat exchanger off the two rear O-ring connections by pulling forwards.

It takes 10 mm of forward movement to clear the O-ring connections. Support the heat exchanger once clear of the top connections.

Note. The heat exchanger weighs 3kg and a quantity of water will remain in the heat exchanger and back panel.

With the heat exchanger clear of the appliance unscrew the bottom return union connection and remove the pipe and washer. Retain the pipe. Discard the washer.

Unscrew the O-ring fitting from the top flow connection.

Discard the washer, O-ring and heat exchanger.

Reassemble the return pipe and O-ring flow fitting in the reverse order to the new heat exchanger.

Ensure the new sealing washers and O-rings are fitted throughout.

Fit the new heat exchanger assembly to the appliance ensuring the centres between the connections are identical to the back panel.

Replace the top right-hand fixing clip behind the heat exchanger. Re-tighten the locating screw, top left-hand side.

Replace the hot and cold water pipes and reconnect the domestic hot water sensor.

Refit the expansion vessel.

Reconnect the domestic hot water sensor.

Refit the expansion vessel.

Open the valves and fill and repressurise the system as described in Section 12.2.

22. Flow Switch and Water Flow Regulator. See Figs. 36 and 47.

Check that the electricity is turned off, remove bottom panel. Drain the domestic hot water circuit as described in 15.2 (b). Lower the facia and control panel as described in 15.1 (b). Unplug the switch connector at the main driver board. (Connector X1 marked flow switch). Release the cord strain relief bush and carefully remove the cable from the control box.

Undo the hexagon nut at each end of the brass flow switch body ensuring to support the brass body with a suitable spanner so as not to overstress the plastic sensing head.

Note the position of the sensing head for replacement purposes.

Remove the flow switch carefully so as not to lose or damage the fibre washers or water flow regulator.

Replace in reverse order making sure the water flow regulator has been cleaned or replaced and the fibre washers are in place.

Tighten up the hexagon nuts carefully while supporting the brass body with a suitable spanner.

Please note the arrow on the sensing head must point upwards and the sensing head must be in the same position as it was before removal.

23. Water Filter. See Figs. 36 and 47.

Check that the electricity supply to the appliance is off. Drain the domestic hot water circuit as described in Section 15.2 (b). Hang the control box assembly in the servicing position as described in Section 15.1 (b). Undo the lower hexagon nut on the flow switch while supporting the brass body of the flow switch with a spanner. Be careful not to lose or damage the fibre washer.

Undo the union nut on the cold water inlet. The water filter is located inside the cold water inlet union. Clean or replace as necessary.

Reassemble in reverse order making sure to replace the fibre washer and support the brass body of the flow switch when tightening the hexagon nut.

24. Pressure Gauge. See Figs. 35 and 36.

Check that the electricity supply to the appliance is turned off.

Drain the central heating circuit as described in Section 15.2(a).

Lower the facia panel as described in Section 15.1(a).

Remove the two M5 nuts securing the gauge to the facia panel and disconnect the capillary at the pressure relief valve.

Fit a replacement gauge in the reverse order ensuring the fibre washer is in place.

Open the valves and fill and repressurise the system as described in Section 12.2.

Fig. 46. Water to Water heat exchanger.

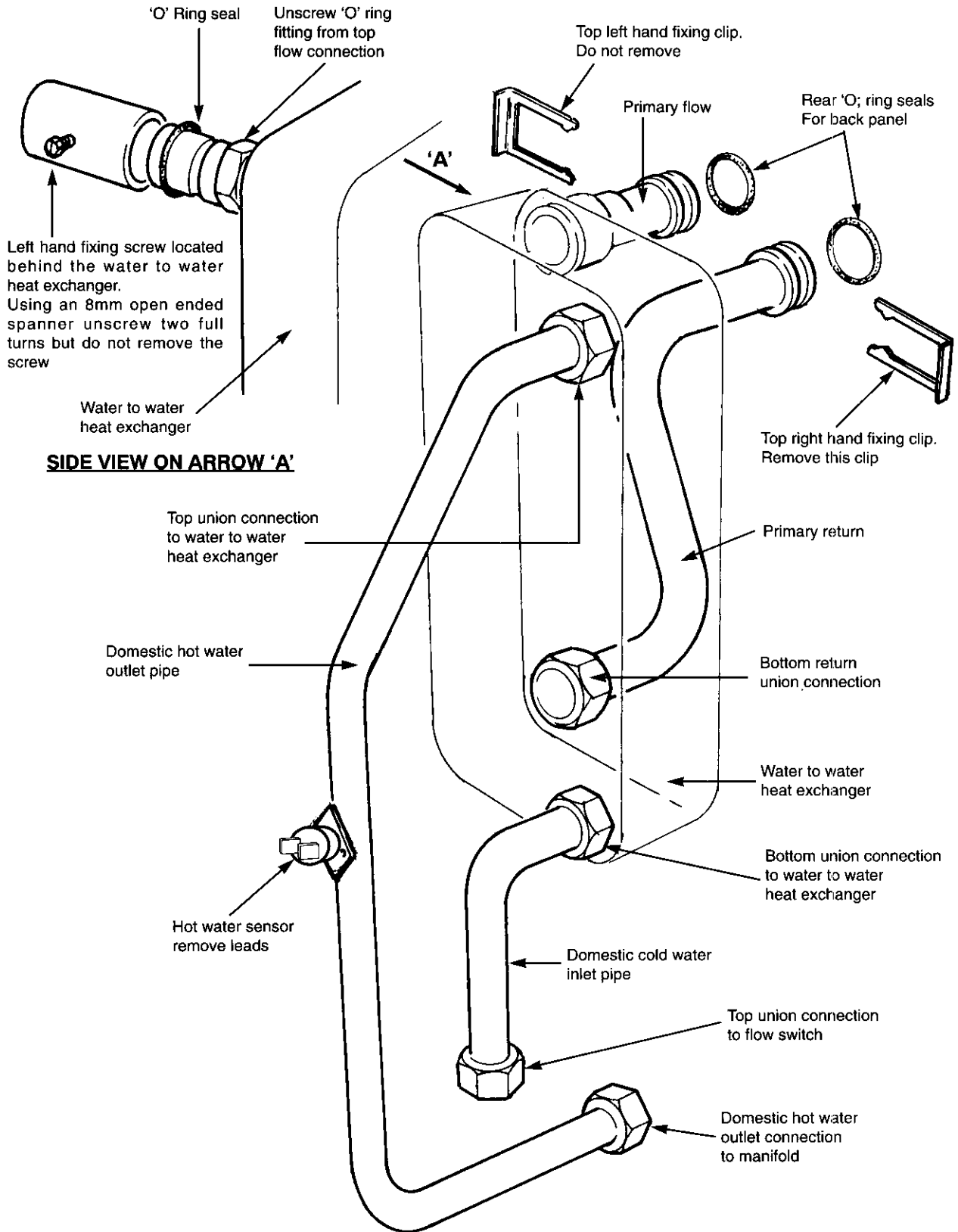

25. Operating Switch. See Fig. 35.

Check that the electricity supply to the appliance is turned off.
Lower the facia panel as described in Section 15.1(a).
Remove the electrical leads from the rear of the switch making note of their positions.
Squeeze together the two plastic retaining lugs to remove the switch from the facia panel.
Snap in the replacement switch and reconnect the electrical leads. Refer to the wiring diagram Fig. 9.

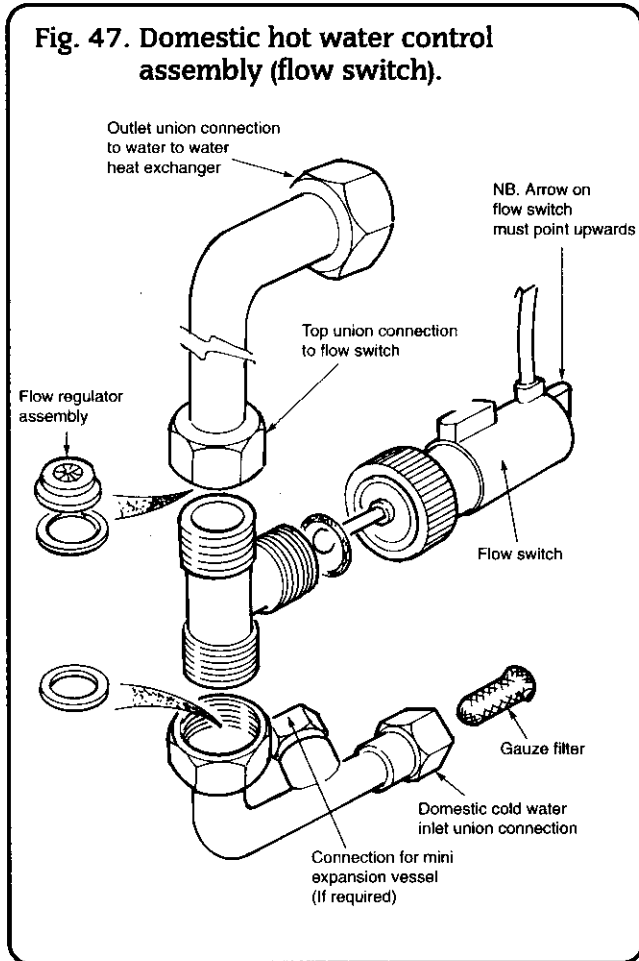

26. Temperature Control Potentiometer. See Fig. 35.

Check that the electricity supply to the appliance is turned off.
Lower the facia panel as described in Section 15.1(a).
Pull the control knob off the potentiometer spindle. Remove the Molex plug from terminal X9 (marked CH CONTROL) on the main driver board. See Fig. 9. Unscrew the locknut and remove from the facia.
Fit a replacement potentiometer in reverse the order.

27. Main Driver Board. See Fig 48.

Check that the electricity supply to the appliance is turned off.
Lower the facia panel as described in Section 15.1(a).
Carefully pull off all the Molex plugs at the main driver board and note their positions. Disconnect all other electrical leads to the board and note their positions.
Release the six plastic catches securing the driver board and pull it forward approximately 3 mm to prevent the plastic catches from returning. The driver board can now be pulled out of the control box.
Fit the replacement board in the reverse order ensuring it is pushed firmly onto the posts and clicks into place.
Refit all the Molex plugs and reconnect all the other electrical leads at the correct terminals. The Molex plugs are not interchangeable and will only fit their respective sockets. Refer to wiring diagram Fig.9.

28. Ignition Control Board. See Fig. 48.

Check that the electricity supply to the appliance is turned off.
Lower the facia panel as described in Section 15.1(a).
Carefully pull off all the Molex plugs at the ignition control board and note their positions. Disconnect all other electrical leads to the board and note their positions.
Release the four plastic catches securing the ignition control board and pull it forward approximately 3 mm to prevent the plastic catches from returning. The ignition control board can now be pulled out of the control box.
Fit the replacement board in the reverse order ensuring it is pushed firmly onto the posts and clicks into place.
Refit all the Molex plugs and reconnect all the other electrical leads at the correct terminals. The Molex plugs are not interchangeable and will only fit their respective sockets. Refer to wiring diagram Fig.9.

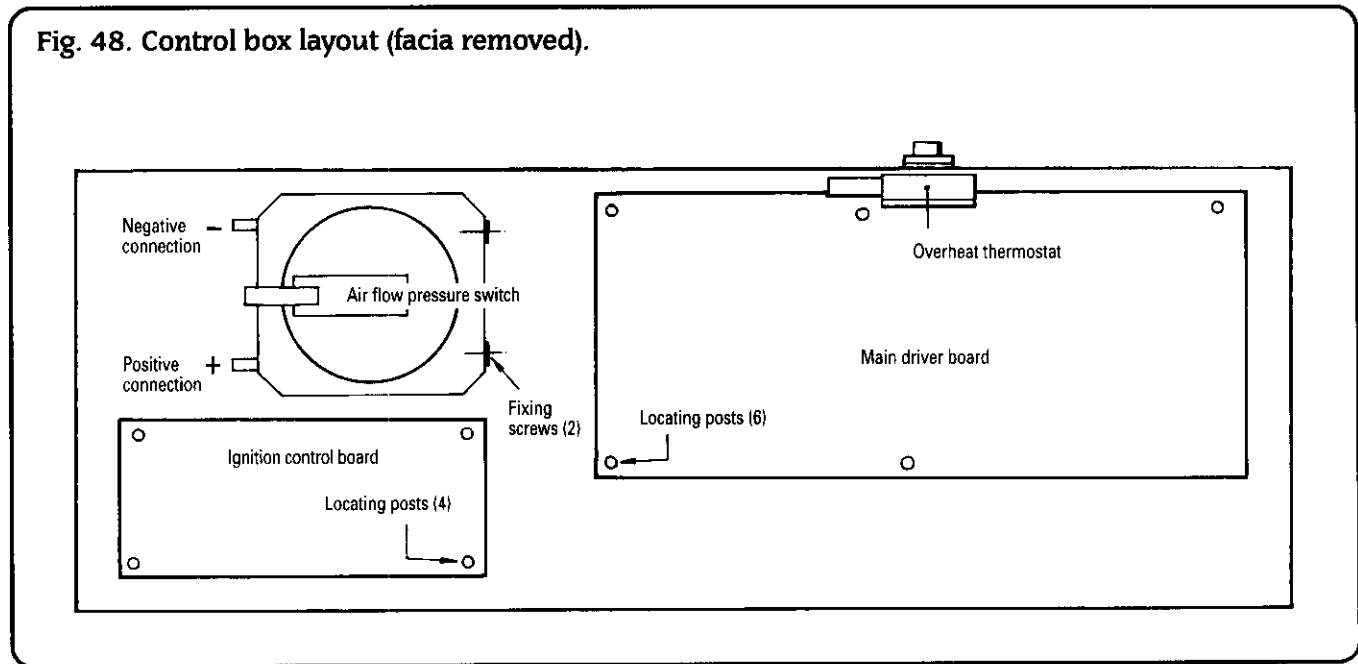

29. Neon Indicator Lights. See Figs.9, 35, 48, 49 and 50. Check that the electricity supply has been turned off.

Lower the facia panel as described in Section 15.1(a).

Unplug the neon connection at terminal **X3** (marked INDICATORS) on the main driver board as follows. See Fig.9.

Use an electrical screwdriver to carefully push down through the locking clip slot to depress the locking clips and withdraw the appropriate leads of the failed neon. See Fig.49.

Remove the neon from the facia panel.

Push the replacement neon into the facia panel. Insert the new neon leads into the plug with the locking clip in the correct position. See Fig.49.

Reconnect the plug to the driver board and reassemble the facia panel.

30(a). Facia Mounted Programmer (if fitted). See Fig.35. Check that the electricity has been turned off.

Lower the facia as described in Section 15.1(a).

Unplug the programmer at terminal **X11** on the main driver board.

Undo the four nuts securing the programmer to the facia and remove.

Fit a new programmer in the reverse order and connect the plug at the main driver board.

30(b). Remote Mounted Programmer (if fitted). See Fig.9.

Check that the electricity has been turned off and isolate the programmer.

Disconnect the leads from the programmer and note their positions.

Fit the replacement programmer and reconnect the leads correctly.

Fig. 49. Neon indicator light plugs.

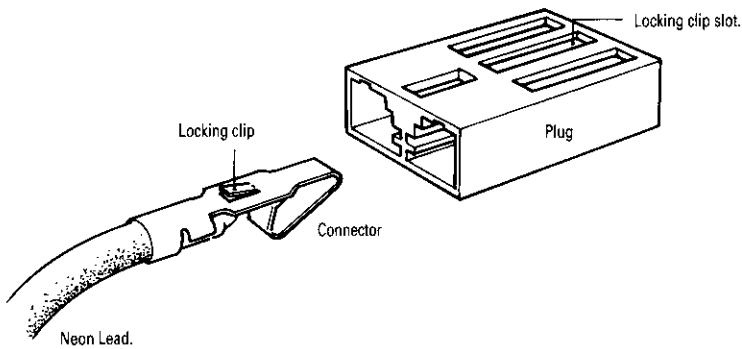
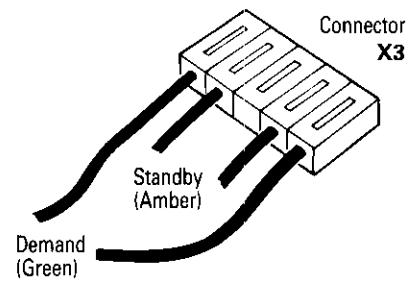

Fig. 50. Neon indicator light connections.



16. Operational Flow Diagrams

Note. The alpha references in these charts are to be used for cross-referencing when fault finding. See Section 17.

44

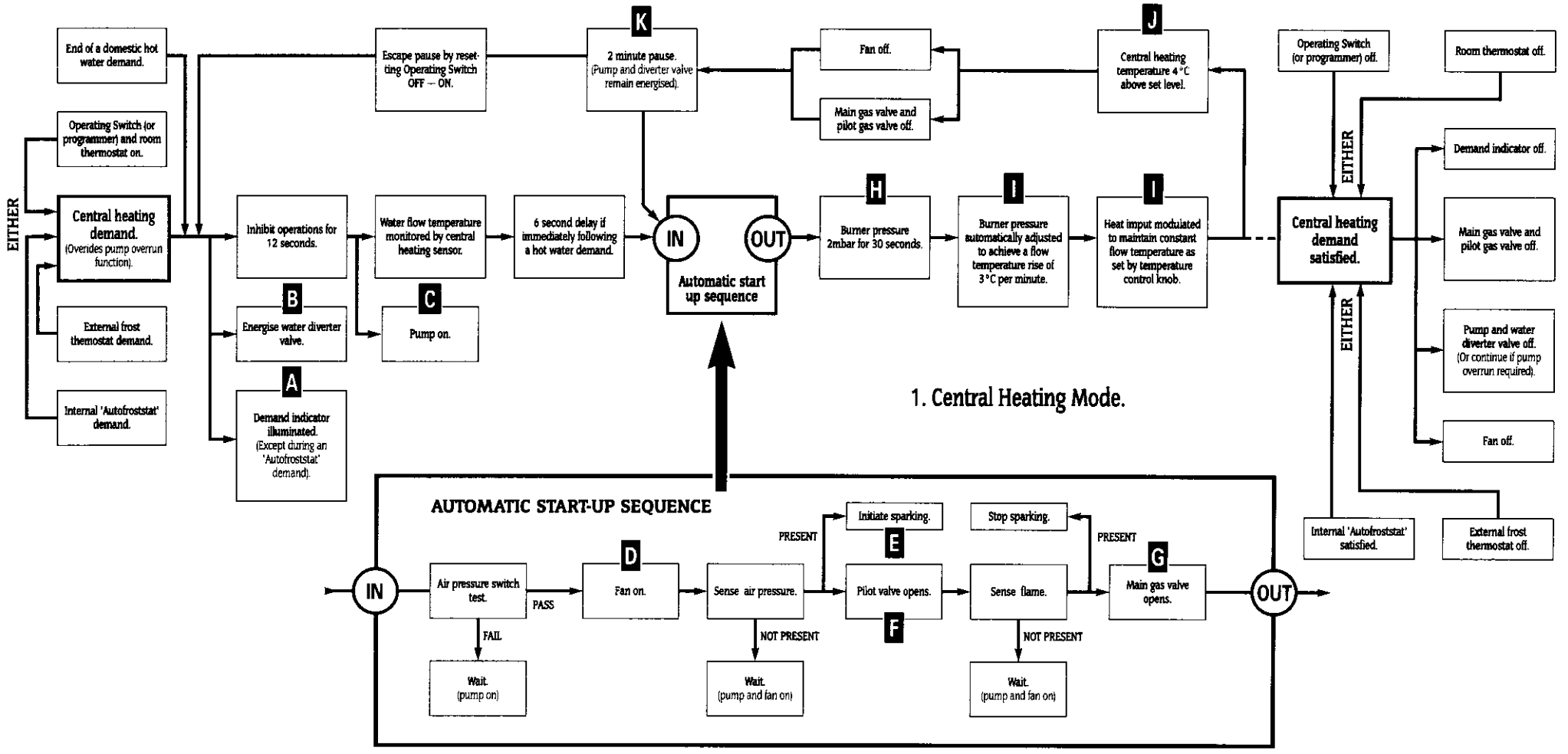

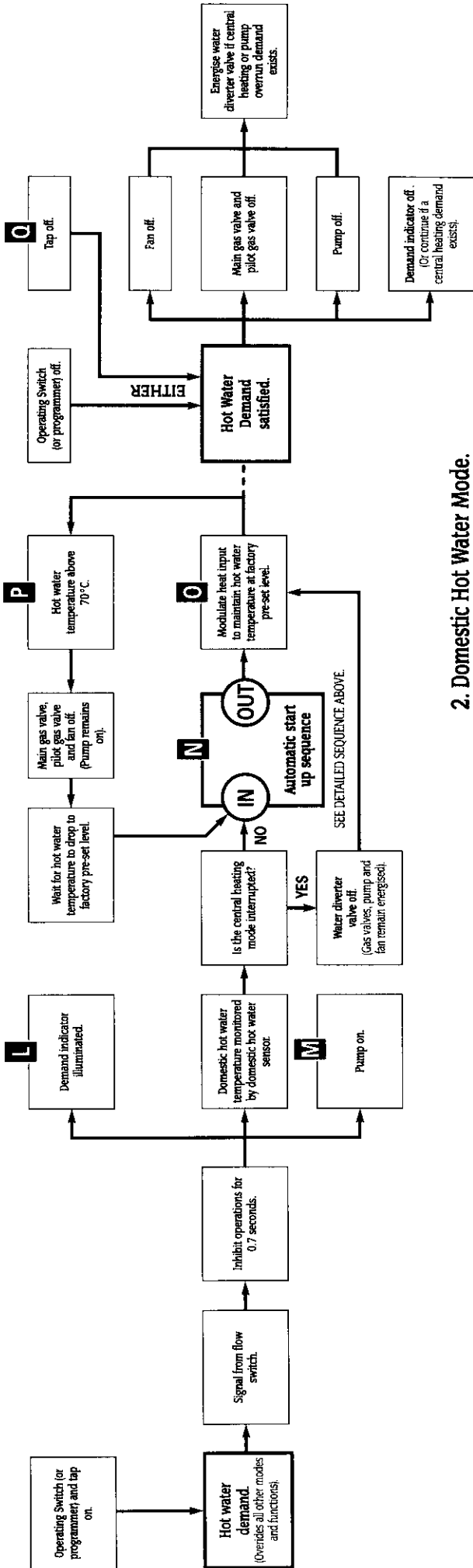

2. Domestic Hot Water Mode.

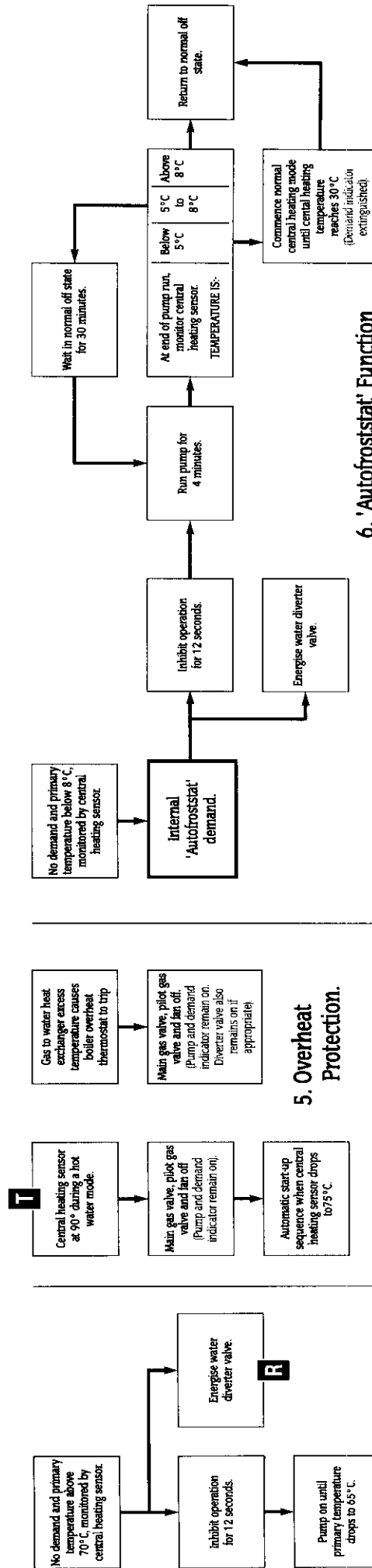

6. 'Autofroststat' Function

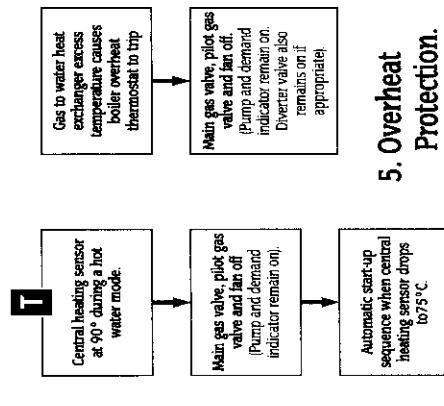

5. Overheat Protection.

4. Primary Protection During Domestic Hot Water Demand.

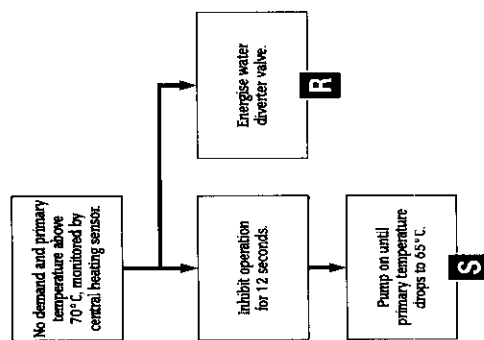

3. Pump Overrun Function.

17. Fault Finding

This Fault Finding Chart is to be used in conjunction with the Operational Flow Diagrams in Section 16. To find the fault, locate the point on the flow diagram at which the appliance has failed, e.g. letter B. Then read the corresponding section in the fault finding chart, e.g. **Failure at point B**. **Note:** Each section assumes that the appliance operates correctly up to that point.

Notes: 1. All voltage measurements are with respect to neutral unless otherwise stated. 2. Before changing any component indicated in the chart, it is essential that the associated wiring is checked for continuity, condition and correct routing. 3. Preliminary electrical system checks are the first electrical checks to be carried out during a fault finding procedure. On completion of the Service/Fault Finding task which has required the breaking and remaking of electrical connections, check—(a) EARTH CONTINUITY, (b) SHORT CIRCUIT CHECK, (c) POLARITY and (d) RESISTANCE TO EARTH.

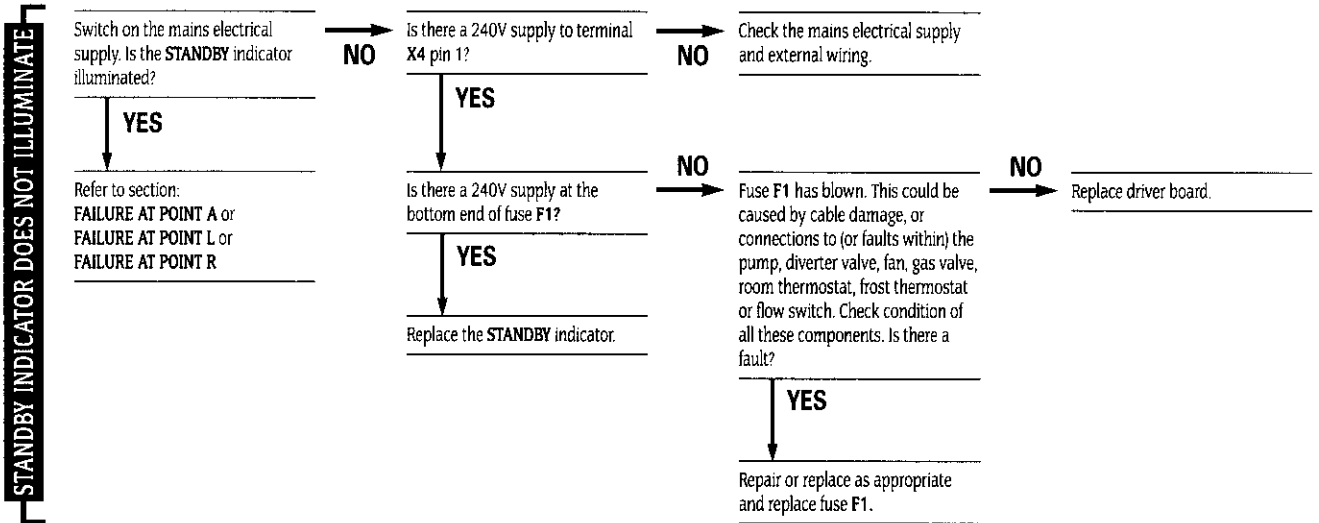

START OF CENTRAL HEATING TEST

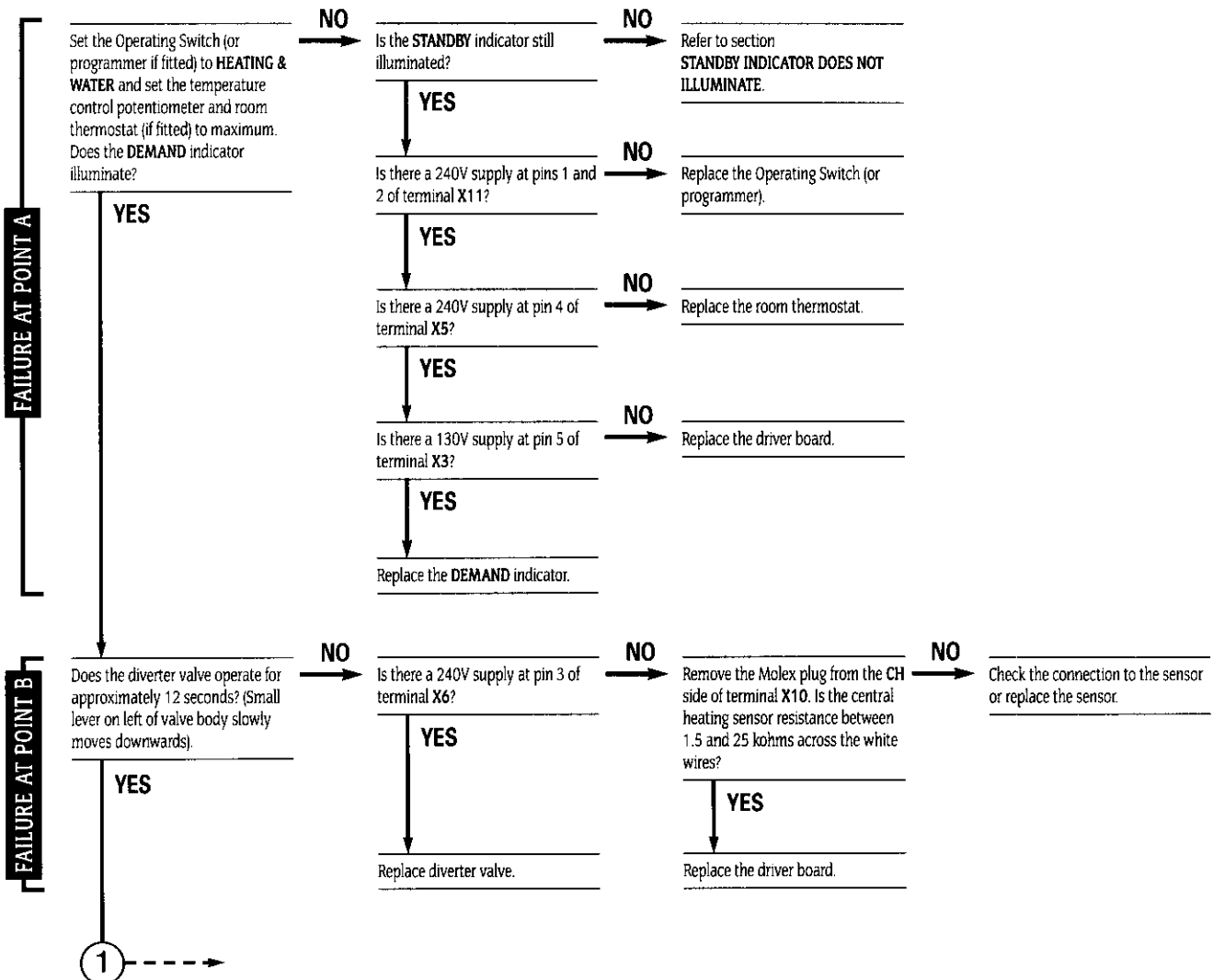

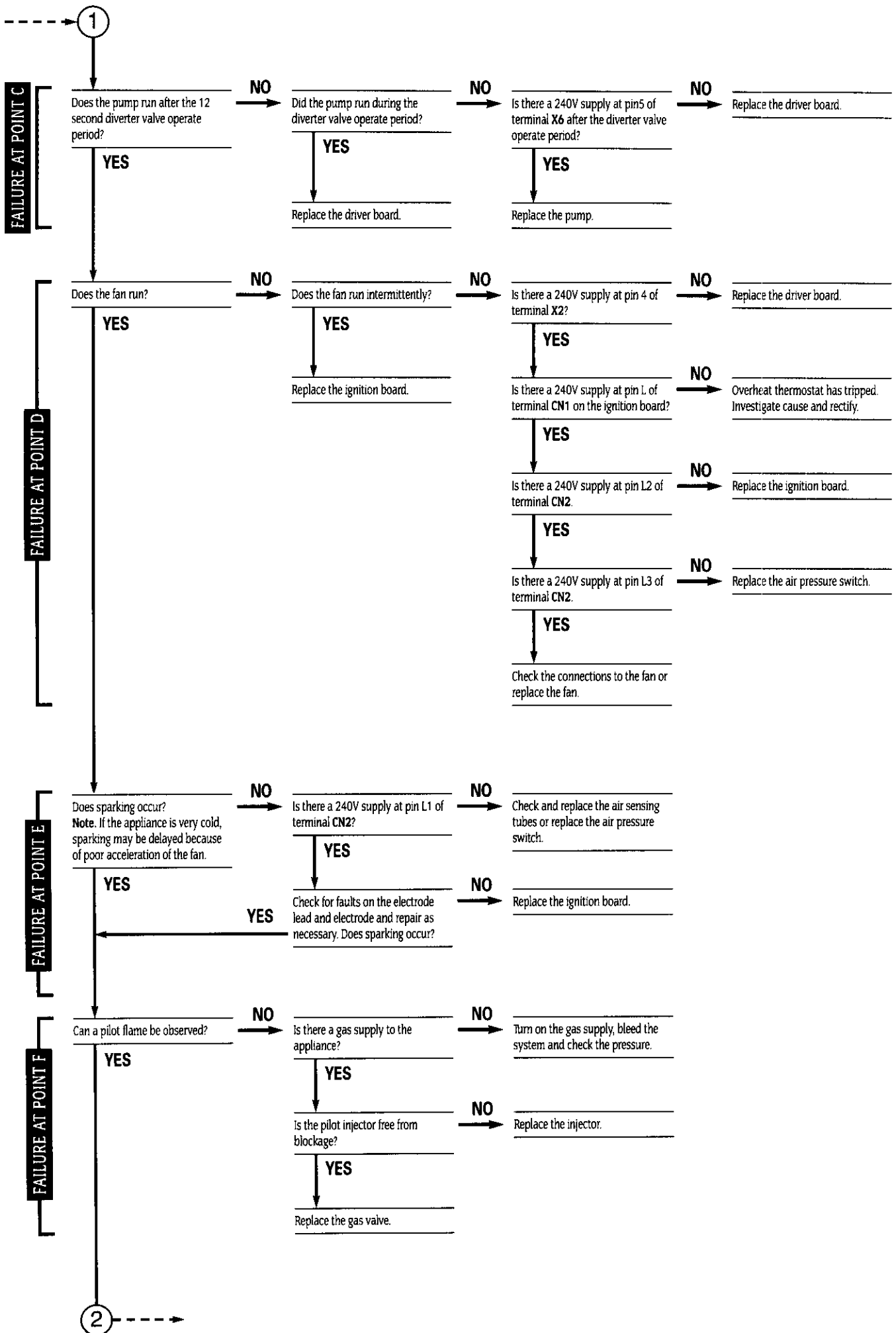

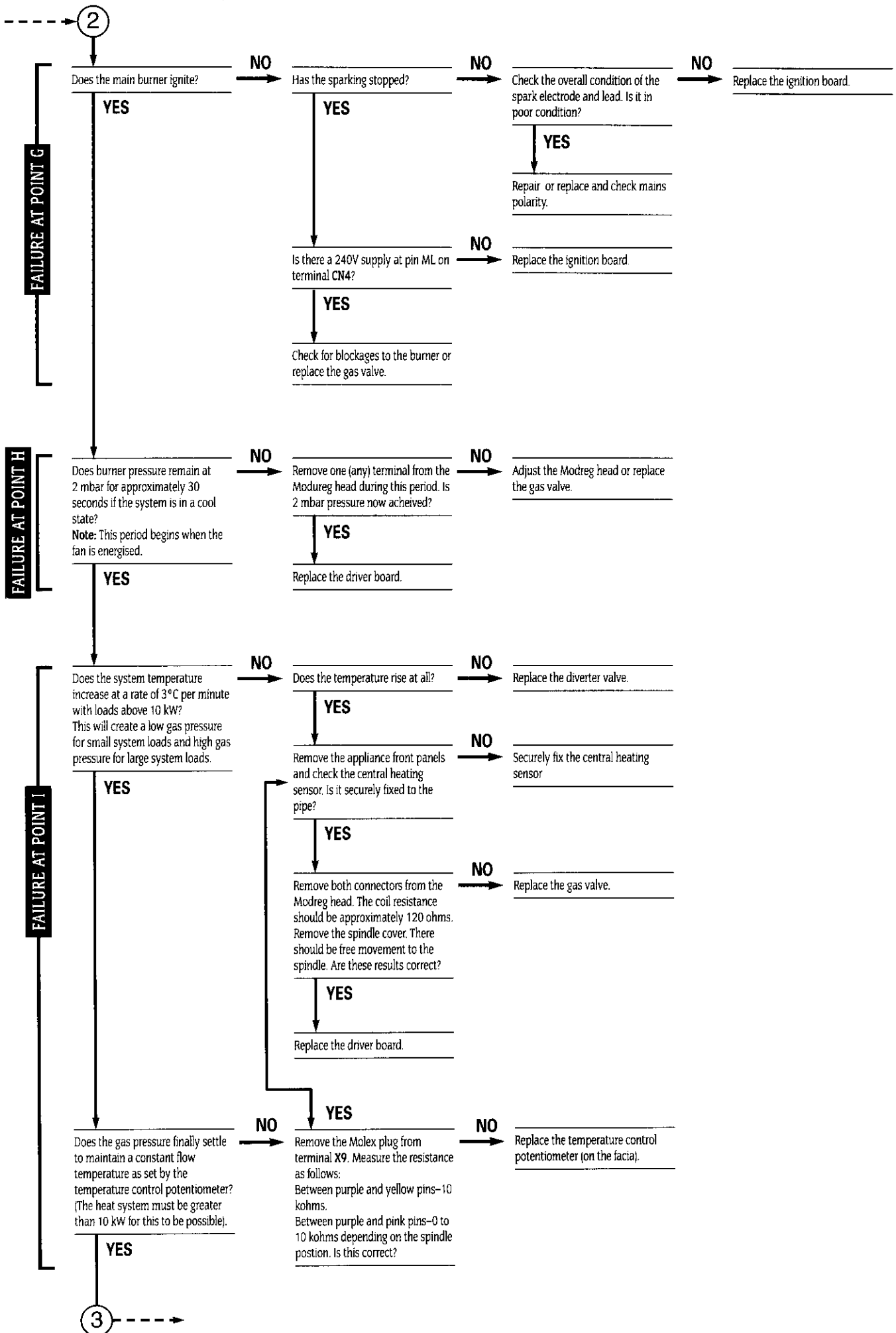

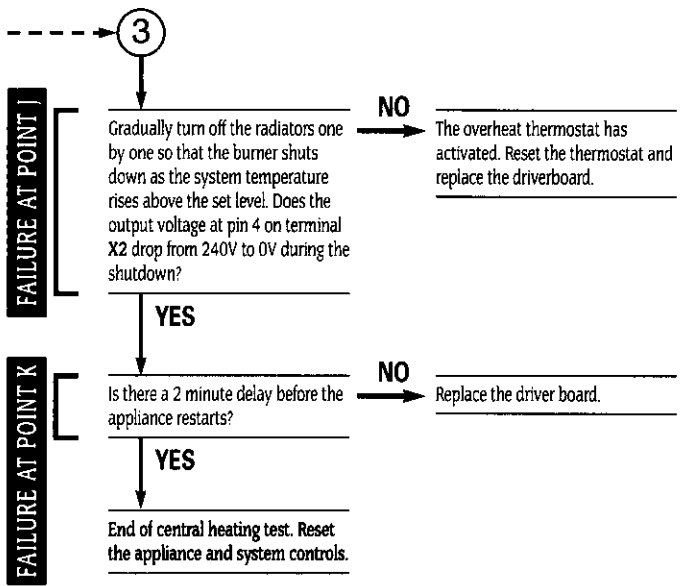

START OF DOMESTIC HOT WATER TEST

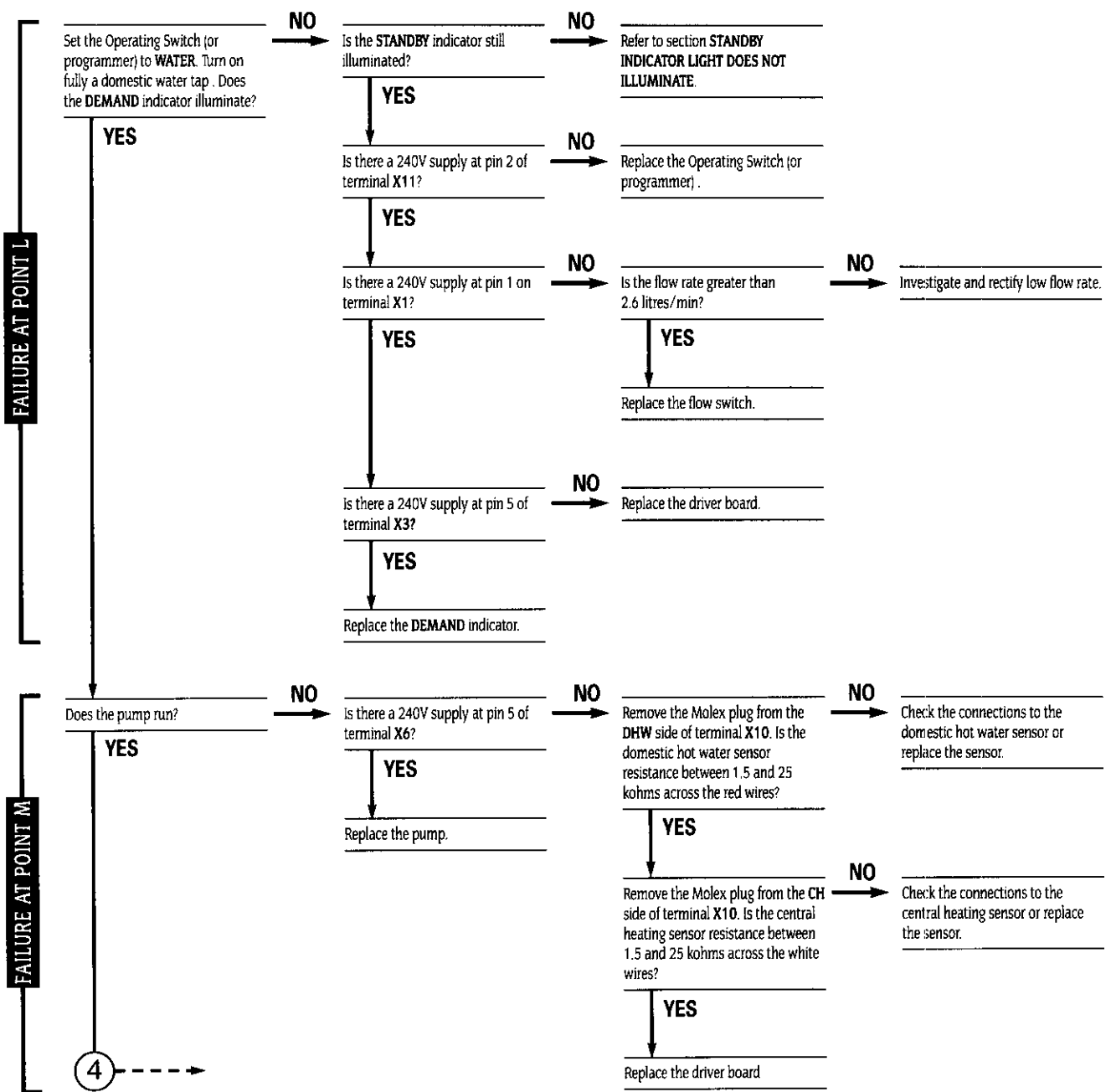

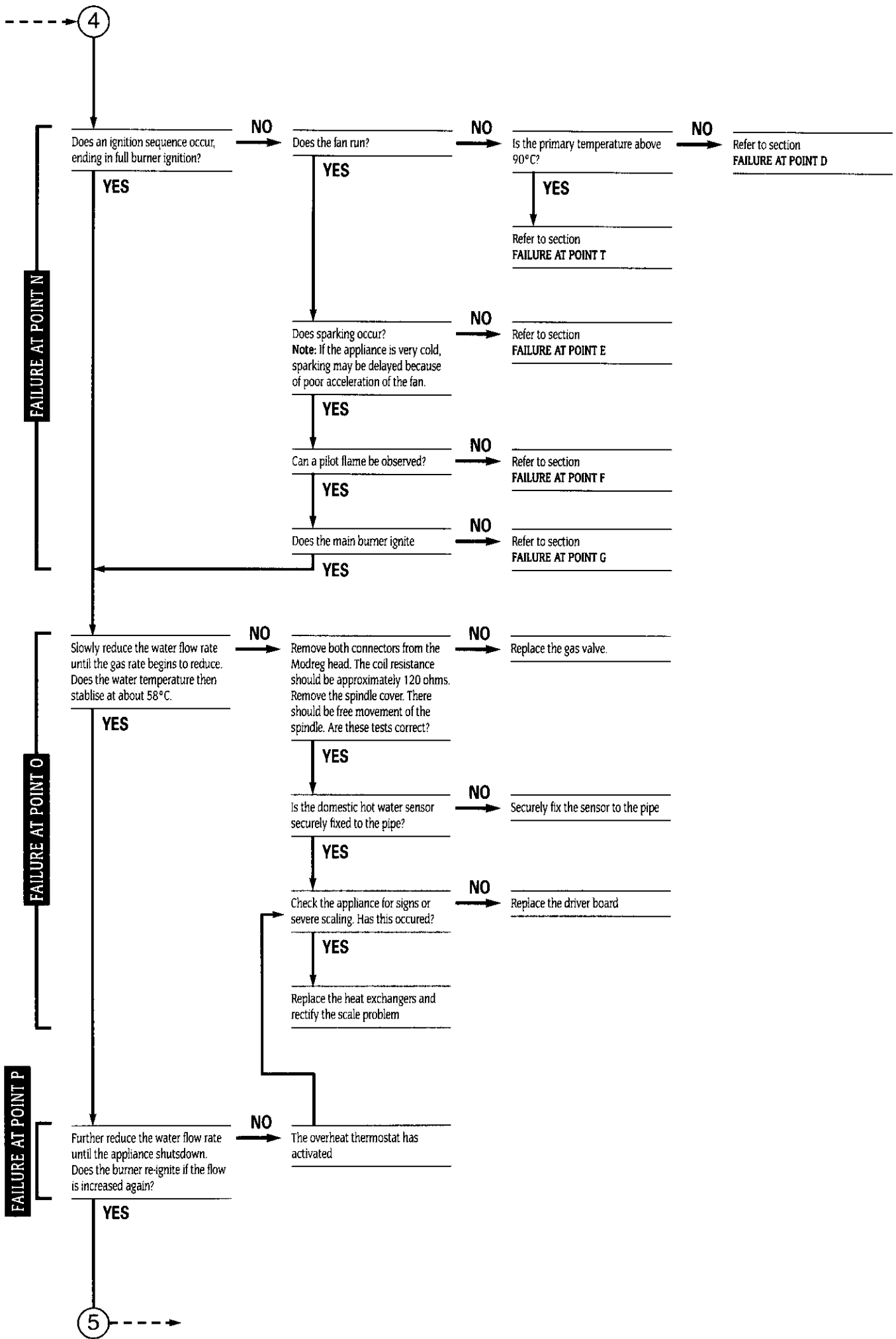

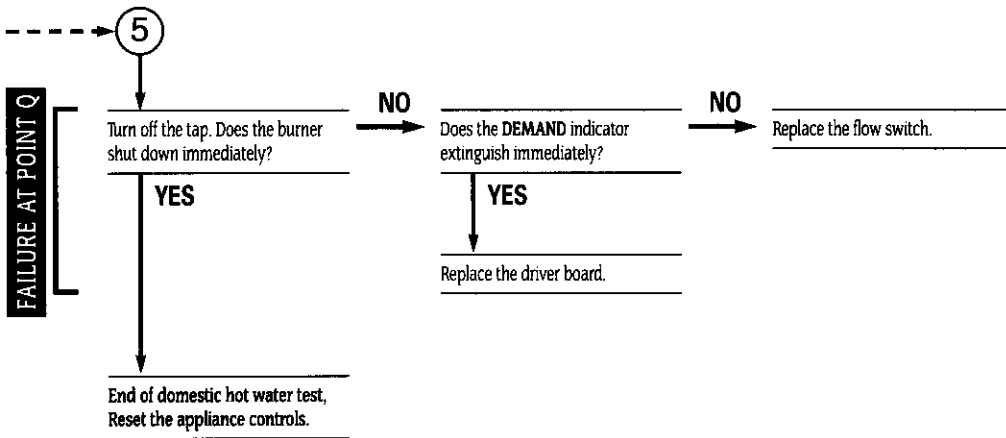

START OF PUMP OVERRUN TEST

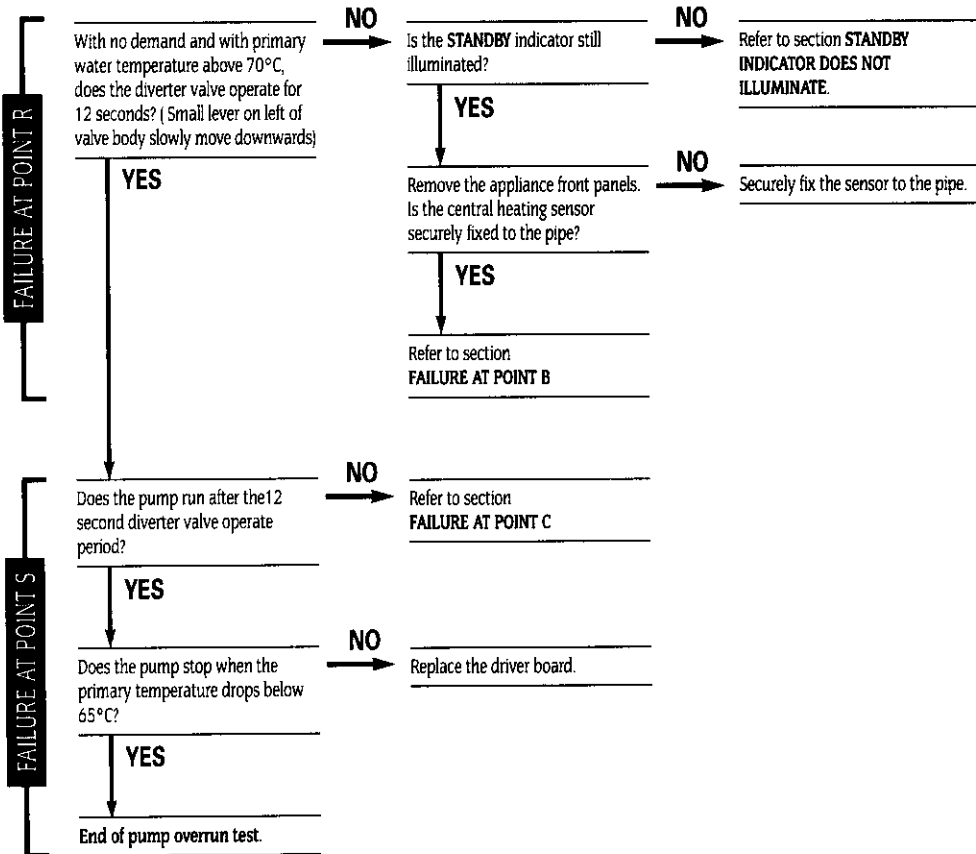

PRIMARY PROTECTION DURING DOMESTIC HOT WATER DEMAND

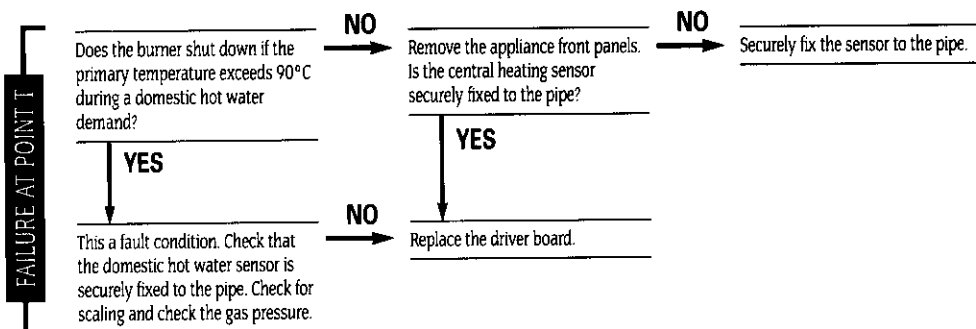

18. Short Parts List

Key No.	GC No.	Part	Manufacturer's Reference	No.	WHS Part No.
1	378 744	Gas Valve	Honeywell VR4601NA2006	1	ZAGAS134
2	379 413	Modureg Pressure Reducing Valve	Honeywell V7335A2224	1	ZAGAS215
3	379 050	Main Burner Assembly	Aeromatic or Furigas	1	ZAGAS170
4	379 052	Main Burner Injector	4.9mm diameter Type 045-072	1	ZAGAS078
5	379 672	Pilot Burner	Honeywell Q385A 2002	1	ZBGAS091
6	382 850	Pilot Burner Injector	Honeywell 45004108-001B	1	ZBGAS016
7	379 561	Spark Electrode c/w lead	Honeywell 45900413-010	1	ZBGAS078
9	299 105	Gas to Water Heat Exchanger		1	ZAGAS149
10	379 419	Automatic Air Vent	Intermes 02, 50, 010	1	ZMMIS055
11	299 199	Thermistor (with paste)	Elmwood 6655-9428-4	1	SPK0039
12	299 202	Pressure Gauge (with washer)	Cewal	1	SPK0040
13	386 789	Pressure Relief Valve	Caleffi 3141, 3bar	1	ZCVLV018
14	386 224	Pump with O-rings	Grundfos 15-60 Special	1	SPK0006
15	371 521	Expansion Vessel (10 litres) with O-ring		1	SPK0005
16	E00/146	Water to Water Heat Exchanger		1	8716142902
17	299 108	Water Diverter Valve (Special)		1	ZAMAJ118
18	378 589	Main Driver Board	Honeywell W7075A1005B	1	ZAGAS127
19	397 569	Ignition Control Board	Pactrol 415000	1	ZAGAS096
20	378 029	Overheat Thermostat	Ranco LM7 P5050	1	ZAMAJ133
21	299 109	Fan Assembly		1	SSA6619/1
22	379 360	Air Pressure Switch	Honeywell (Yamatagi) C6065A 1002	1	ZAGAS188
23	386 227	CH Temperature Control Potentiometer	Omeg OW 20BU 10KA	1	SSAHAR002
24	386 778	Operating Switch	Arrow 200400E839 AA		ZDELE237
25	299 110	Combustion Chamber Insulation (Complete)		1	SPK0027
26	371 539	Programmer Kit (Optional)	WHS Single Channel Grey 490 488	1	ZAMAJ164
27	371 536	Gasket Pack – Gas		1	SPK0020
28	371 535	Gasket Pack – Water		1	SPK0019
29	394 291	Flow Regulator	Type E Blue 10 litres/min (\pm 15%)	1	ZBUNC140
30	371 524	Indicator Light – DEMAND	Neon (Green) – complete with plug IMO Ref. NI9RL 240G/S300-Green	1	SSAHAR081
31	371 525	Indicator Light – STANDBY	Neon (Amber) – complete with plug IMO Ref. NI9RL 240A/S300-Amber	1	SSAHAR082
32	379 615	Flow Switch	Sika VK315M	1	ZDELE586
33	324 822	Gauze Filter		1	ZBUNC230

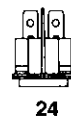
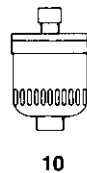
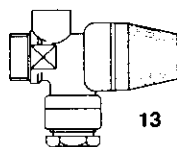
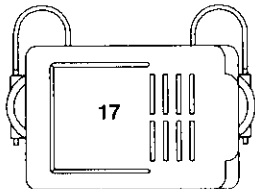
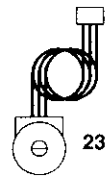
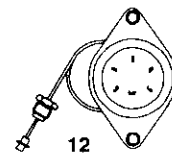
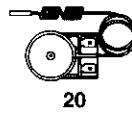
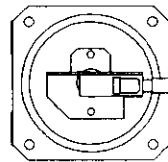
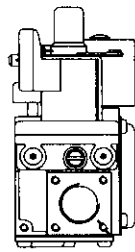
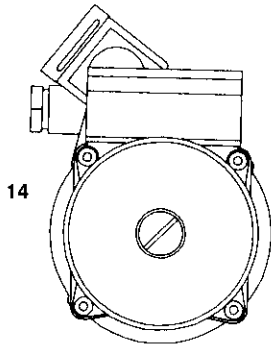
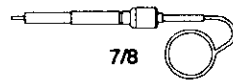
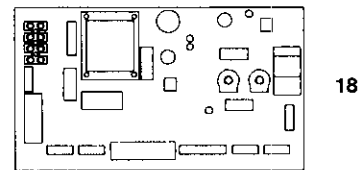
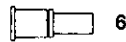
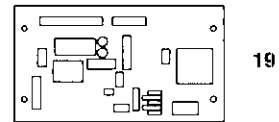
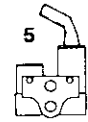
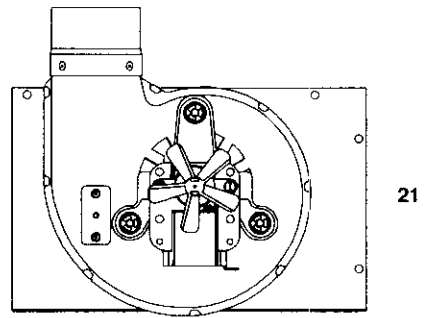
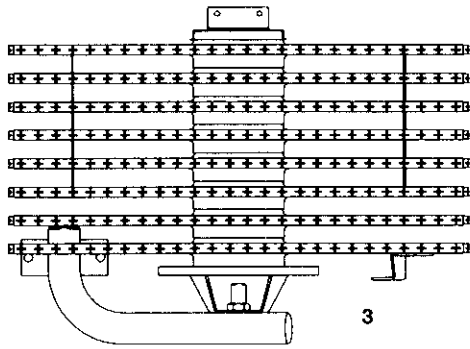
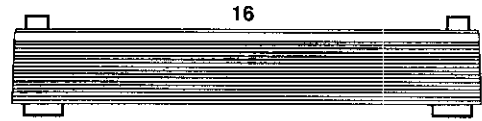
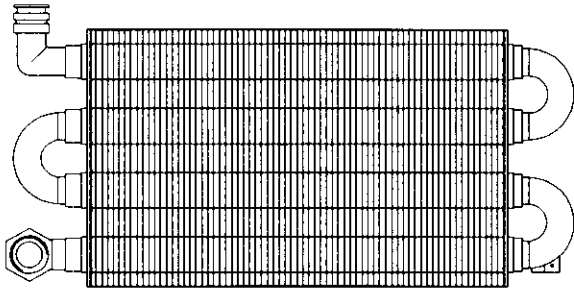
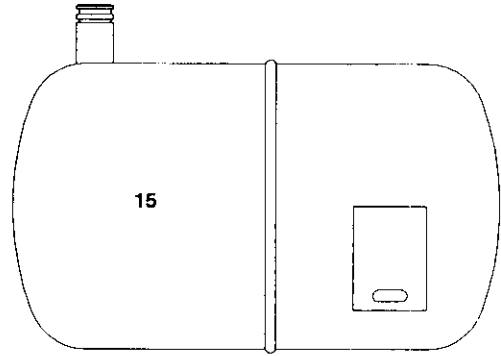
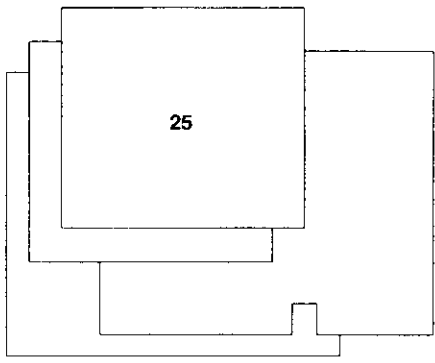

30

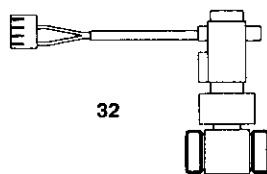
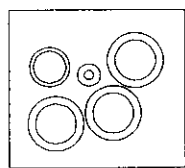
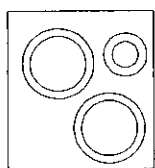

31

Parts key numbers



*Worcester Heat Systems Limited, Cotswold Way, Warndon, Worcester, WR4 9SW.
Telephone: (01905) 754624. Fax: (01905) 754619.
Technical Helpline: (0990) 266241.*

This booklet is accurate at the date of printing but will be superseded and should be disregarded if specifications and/or appearances are changed in the interests of continued improvement.
All goods sold are subject to our official Conditions of Sale, a copy of which may be obtained on application.

PUBLICATION 8 716 145 024, ISSUE 2 – FEBRUARY 1997