

For the competent person

Installation and maintenance instructions



ecoTEC pro

VUW

GB, IE

Publisher/manufacturer

Vaillant GmbH

Berghauser Str. 40 D-42859 Remscheid
Tel. +49 21 91 18-0 Fax +49 21 91 18-28 10
info@vaillant.de www.vaillant.de

Contents

1	Safety	4	7.5	Preventing low water pressure	19
1.1	Action-related warnings	4	7.6	Flushing the heating installation for the first time ("cold")	19
1.2	Intended use	4	7.7	Filling the heating installation	19
1.3	General safety information	4	7.8	Purging the heating installation	20
1.4	Related documents	6	7.9	Filling and purging the hot water system	20
1.5	Related documents	7	7.10	Filling the condensate trap	20
2	Notes on the documentation	8	7.11	Gas ratio setting	20
2.1	Observing other applicable documents	8	7.12	Checking function and leak-tightness	23
2.2	Storing documents	8	7.13	Thoroughly flushing the heating installation ("hot")	23
2.3	Applicability of the instructions	8	8	Adapting the unit to the heating installation	23
2.4	Benchmark	8	8.1	Calling up diagnostics codes	23
2.5	Local regulations	8	8.2	Burner anti-cycling time	23
3	Product description	8	8.3	Setting the maintenance interval	24
3.1	Product design	8	8.4	Setting the pump output	24
3.2	Information on the identification plate	8	8.5	Setting the bypass valve	24
3.3	Serial number	9	8.6	Handing the product over to the operator	25
3.4	CE label	9	9	Troubleshooting	25
3.5	Energy Saving Trust Endorsed Products	9	9.1	Checking service messages	25
4	Installation	9	9.2	Rectifying faults	25
4.1	Unpacking the product	9	9.3	Calling up and clearing the fault memory	25
4.2	Checking the scope of delivery	9	9.4	Resetting parameters to factory settings	25
4.3	Transporting the product	9	9.5	Preparing the repair work	25
4.4	Dimensions	10	9.6	Replacing defective components	25
4.5	Minimum clearances	11	9.7	Completing repair work	27
4.6	Clearance from combustible components	11	10	Inspection and maintenance	28
4.7	Using the installation template	11	10.1	Removing the compact thermal module	28
4.8	Wall-mounting the product	11	10.2	Cleaning the heat exchanger	29
4.9	Removing the front casing	11	10.3	Checking the burner	29
4.10	Removing the side section	12	10.4	Cleaning the condensate trap	29
5	Installation	12	10.5	Cleaning the filter in the cold water inlet	29
5.1	Installation requirements	12	10.6	Installing the compact thermal module	30
5.2	Installing the gas connection	13	10.7	Draining the product	30
5.3	Installing the hot and cold water connection	13	10.8	Checking the pre-charge pressure for the internal expansion vessel	30
5.4	Connecting the heating flow and heating return	13	10.9	Completing inspection and maintenance work	30
5.5	Connecting the condensate drain pipework	14	11	Decommissioning	30
5.6	Installing the discharge pipe on the expansion relief valve	14	11.1	Temporarily decommissioning the product	30
5.7	Flue gas installation	14	11.2	Decommissioning the product	30
5.8	Electrical installation	15	12	Recycling and disposal	30
6	Operation	17	13	Customer service	30
6.1	Operating concept	17	Appendix	31	
6.2	Installer level overview	17	A	Overview of diagnostics codes	31
6.3	Calling up the installer level	17	B	Status codes – Overview	34
6.4	Live Monitor (status codes)	17	C	Overview of fault codes	35
6.5	Setting the hot water temperature	18	D	Connection diagrams	38
7	Start-up	18	D.1	Product connection diagram with integrated hot water generation	38
7.1	Carrying out the initial start-up	18	E	Inspection and maintenance work – Overview	39
7.2	Switching the product on and off	18	F	Commissioning Checklist	40
7.3	Using check programmes	18			
7.4	Checking and treating the heating water/filling and supplementary water	18			

G	Opening of the flue pipe.....	44
G.1	Positioning of the opening of a fan-supported flue gas pipe	44
H	Text from BS 5440-1 on fan-supported flue gas pipes	45
I	Opening of the flue pipe below eaves and balconies	45
J	Technical data.....	45
Index	49

1 Safety

1 Safety

1.1 Action-related warnings

Classification of action-related warnings

The action-related warnings are classified in accordance with the severity of the possible danger using the following warning signs and signal words:

Warning symbols and signal words



Danger!

Imminent danger to life or risk of severe personal injury



Danger!

Risk of death from electric shock

Warning.

Risk of minor personal injury



Caution.

Risk of material or environmental damage

1.2 Intended use

There is a risk of injury or death to the user or others, or of damage to the product and other property in the event of improper use or use for which it is not intended.

The product is intended as a heat generator for closed heating installations and for hot water generation.

The products referred to in these instructions must only be installed and operated in conjunction with the flue pipe accessories listed in other applicable documents.

Exceptions: For C63 and B23P installation types, follow the specifications in these instructions.

Intended use includes the following:

- observance of accompanying operating, installation and servicing instructions for the product and any other system components
- installing and fitting the product in accordance with the product and system approval
- compliance with all inspection and maintenance conditions listed in the instructions.

Any other use that is not specified in these instructions, or use beyond that specified in

this document shall be considered improper use. Any direct commercial or industrial use is also deemed to be improper.

Caution.

Improper use of any kind is prohibited.

1.3 General safety information

1.3.1 Risk caused by inadequate qualifications

Assembly and disassembly, installation, start-up, maintenance, repairs and decommissioning must only be carried out by a competent person who is sufficiently qualified to observe all of the instructions that come with the product, to proceed in accordance with the current state of the art, and to comply with all applicable directives, standards, laws and other regulations.

1.3.2 Risk of death from escaping gas

What to do if you smell gas in the building:

- ▶ Avoid rooms that smell of gas.
- ▶ If possible, open doors and windows fully and ensure adequate ventilation.
- ▶ Do not use naked flames (e.g. lighters, matches).
- ▶ Do not smoke.
- ▶ Do not use any electrical switches, mains plugs, doorbells, telephones or other communication systems in the building.
- ▶ If it is safe to do so, close the emergency control valve or the main isolator.
- ▶ If possible, close the gas isolator cock on the product.
- ▶ Warn other occupants in the building by yelling or banging on doors or walls.
- ▶ Leave the building immediately and ensure that others do not enter the building.
- ▶ Notify the gas supply company or National Grid Transco +44 (0) 800 111999 by telephone from outside of the building.

1.3.3 Risk of death from leaks if the product is installed below ground level!

Liquid gas is accumulating at floor level. If the product is installed below ground level, liquid gas may accumulate at floor level if there





are any leaks. In this case, there is a risk of explosion.

- ▶ Make sure that liquid gas cannot escape from the product or the gas line under any circumstance.

1.3.4 Risk of death due to blocked or leaking flue gas routes

Installation errors, damage, tampering, unauthorised installation sites or similar can cause flue gas to escape and result in a risk of poisoning.

What to do if you smell flue gas in the property:

- ▶ Open all accessible doors and windows fully to provide ventilation.
- ▶ Switch off the product.
- ▶ Check the flue gas routes in the product and the flue gas diversions.

1.3.5 Risk of poisoning and burns caused by escaping hot flue gases

- ▶ Only operate the product if the air/flue pipe has been completely installed.
- ▶ With the exception of short periods for testing purposes, only operate the product when the front casing is installed and closed.

1.3.6 Risk of death due to explosive and flammable materials

- ▶ Do not use or store explosive or flammable materials (e.g. petrol, paper, paint) in the installation room of the product.

1.3.7 Risk of death due to cabinet-type casing

Cabinet-type casing can give rise to dangerous situations when used on a product which is operated with an open flue.

- ▶ Ensure that the product is supplied with sufficient combustion air.

1.3.8 Risk of poisoning caused by insufficient supply of combustion air

Conditions: Open-flued operation

- ▶ Ensure that the air supply to the product's installation room is permanently unobstructed and sufficient in accordance with the relevant ventilation requirements.

Compartment ventilation

The boilers are very high efficiency appliances. As a consequence the heat loss from the appliance casing during operation is very low. Compartment ventilation is required if the flue used is not concentric and air is supplied from the room or compartment the boiler is installed in.

1.3.9 Risk of death due to lack of safety devices

The schematic drawings included in this document do not show all safety devices required for correct installation.

- ▶ Install the necessary safety devices in the system.
- ▶ Observe the applicable national and international laws, standards and guidelines.

1.3.10 Risk of death from electric shock

There is a risk of death from electric shock if you touch live components.

Before commencing work on the product:

- ▶ Disconnect the product from the power supply by switching off all power supplies (electrical partition with a contact opening of at least 3 mm, e.g. fuse or line protection switch).
- ▶ Secure against being switched back on again.
- ▶ Wait for at least 3 minutes until the capacitors have discharged.
- ▶ Check that there is no voltage.

1.3.11 Risk of being burned or scalded by hot components

- ▶ Only carry out work on these components once they have cooled down.

1 Safety

1.3.12 Risk of death from escaping flue gas

If you operate the product with an empty condensate trap, flue gas may escape into the room air.

- ▶ In order to operate the product, ensure that the condensate trap is always full.

1.3.13 Risk of material damage caused by using an unsuitable tool

- ▶ Use the correct tool to tighten or loosen screw connections.

1.3.14 Risk of material damage caused by frost

- ▶ Do not install the product in rooms prone to frost.

1.3.15 Risk of corrosion damage due to unsuitable combustion and room air

Sprays, solvents, chlorinated cleaning agents, paint, adhesives, ammonia compounds, dust or similar substances may lead to corrosion on the product and in the air/flue pipe.

- ▶ Ensure that the supply of combustion air is always free of fluorine, chlorine, sulphur, dust, etc.
- ▶ Ensure that no chemical substances are stored at the installation site.
- ▶ Ensure that the combustion air is not routed through chimneys which have previously been used with floor-standing oil-fired boilers, or with other boilers, which could cause soot to build up in the chimney.
- ▶ If you are installing the product in hairdressing salons, painter's or joiner's workshops, cleaning businesses or similar locations, choose a separate installation room in which a combustion air supply is ensured that is technically free of chemical substances.

1.4 Related documents

Installation and maintenance of the boiler must only be performed by a competent person with valid accreditation from the Health and Safety Executive in accordance with the "Gas Safety (Installation and Use) Regulations 1998" (hereinafter abbreviated to "competent person" or "heating specialist company"). The existing regulations, rules and guidelines must be observed when doing so. Any special requirements of Local Authorities, gas undertakings or insurers must be complied with. The competent person is also responsible for inspection, maintenance and repairs to the boiler, and for checking gas volume setting and flue gas analysis.

Installers shall carry out a full site risk assessment and put into place all necessary steps and procedures to comply with Health and safety at work act and ensure safety of themselves and others with regard to manual handling and working at height requirements.

During the appliance installation (and any subsequent work, such as, the replacement of major parts) it will be necessary to employ caution. All installers and operatives involved from unloading the appliance until it is fully mounted on the wall in its final installed location must exercise full duty of care for themselves and others with regard to safety. When lifting and handling this appliance, operatives should employ assistance. In certain situations it may be necessary to use mechanical handling aids. Take care to avoid trip hazards, slippery or wet surfaces.

Employers and installers should refer to the HSE web site for full advice and manual handling assessment charts (MAC) tool.

In addition where no specific instructions are given then reference shall be made, but not restricted to, all applicable and relevant British Standards and codes of practice such as the following:

- Gas Safety (Installation and Use) regulations.
- All current Building Regulations for England, Northern Ireland and Wales, (as amended). This includes Approved Codes of Practice and approved documents and



- guidance for building regulations. (A to P and 7)
 - The Building Standards, Scotland, and any requirements determined by the local authorities within.
 - The Health and safety at work act
 - COSHH Control of Substances Hazardous to Health.
 - BS 7671 Requirements for electrical installations. IEE Wiring Regulations
 - The Electricity at Work Regulations.
 - The Water supply (water fittings) regulations 1999.
 - Water bylaws 2000 (Scotland)
 - BS 5854 Code of practice for flues and flue structures in buildings.
 - BS EN 12828 Design of water-based heating systems.
 - BS EN 806 Parts 1 - 5.
 - BS 8558 Guide to the design, installation, testing and maintenance of services supplying water for domestic use within buildings and their curtilages.
 - BS 6880 Code of practice for low temperature heating systems with outputs above 45 kW, Part 1, 2, and 3.
 - BS 6891 Installation of low pressure gas pipe work of up to 35mm in domestic premises.
 - BS 4814 Specification for: Expansion vessels using an internal diaphragm, for sealed hot water and heating systems.
 - BS 7074 Application, selection and installation of expansion vessels and ancillary equipment for sealed water systems., Part 1 and 2.
 - BS 7593 Code of practice for treatment of water in domestic hot water central heating systems.
 - BS 12831 Heating systems in buildings. Method for calculating design heat load.
 - BS EN 13831 Closed expansion vessels with built in diaphragm.
 - EN 14336 Heating systems in buildings. Installation and commissioning of water based heating systems.
 - BS 5440 – 1 Installation of flues and ventilation for gas appliances of rated input not exceeding 70kW*
 - BS 5440 – 2 Flueing and ventilation for gas appliances of rated input not exceeding 70kW*
 - * 1st 2nd and 3rd family gases.
 - BS 5449 Forced circulation hot water systems up to 45kW.
 - BS EN 6798 Installation & maintenance of gas fired hot water boilers of rated input not exceeding 70kW net.
 - BS 5482 - Part 1 Domestic butane and propane gas burning installations
- Institute of Gas Engineers Publications:
- IGE/UP/1B (Edition 2) Tightness testing and direct purging of small natural gas installations.
 - IGE/UP/ 7 (Edition 2) Gas in timber and light steel framed buildings.
- Additionally for gas boilers systems with outputs greater than 70KW.
- BS 6644 Installation of gas boilers between 60 kW and 2 MW (2nd and 3rd family gases)
 - BS 5449
 - IGE/UP/1 (Edition 2) Strength testing, tightness testing and direct purging of industrial and commercial gas installations.
 - IGE/UP/1A (Edition 2) Strength testing, tightness testing and direct purging of small, low pressure industrial and commercial natural gas installations.
 - IGE/UP/10 Installation of gas appliances in industrial and commercial premises. Part 1 Flued appliances.
 - The installation must comply with the current version of the Clean Air Act.

1.5 Related documents

- I.S. 813 Domestic Gas Installations
- I.S. 820 Non Domestic Gas Installations
- Building Control Act 2007
- ETCI Regulations for installing electrical systems

2 Notes on the documentation

2 Notes on the documentation

2.1 Observing other applicable documents

- ▶ You must observe all the operating and installation instructions included with the system components.

2.2 Storing documents

- ▶ Pass these instructions and all other applicable documents on to the system operator.

2.3 Applicability of the instructions

These instructions apply only to:

Product article number

	Article number	Gas Council Number
24 (VUW GB 246/5-3 A) ecoTEC pro	0010018494	47-044-54
28 (VUW GB 286/5-3 A) ecoTEC pro	0010018495	47-044-55
28 (VUW GB 286/5-3 A LPG) ecoTEC pro	0010018496	47-044-56
30 (VUW GB 306/5-3) ecoTEC pro	0010016538	47-044-52

2.4 Benchmark

Vaillant is a licensed member of the Benchmark Scheme which aims to improve the standards of installation and commissioning of domestic heating and hot water systems in the UK and to encourage regular servicing to optimise safety, efficiency and performance.

Benchmark is managed and promoted by the Heating and Hotwater Industry Council.



For more information visit www.centralheating.co.uk

2.5 Local regulations

Benchmark places responsibilities on both manufacturers and installers. The purpose is to ensure that customers are provided with the correct equipment for their needs, that it is installed, commissioned and serviced in accordance with the manufacturer's instructions by a competent person approved at the time by the Health and Safety Executive and that it meets the requirements of the appropriate Building Regulations. The Benchmark Checklist can be used to demonstrate compliance with Building Regulations and should be provided to the customer for future reference.

Installers are required to carry out installation, commissioning and servicing work in accordance with the Benchmark Code of Practice which is available from the Heating and Hotwater Industry Council who manage and promote the Scheme.

3 Product description

3.1 Product design

3.1.1 Functional elements, product with integrated hot water generation

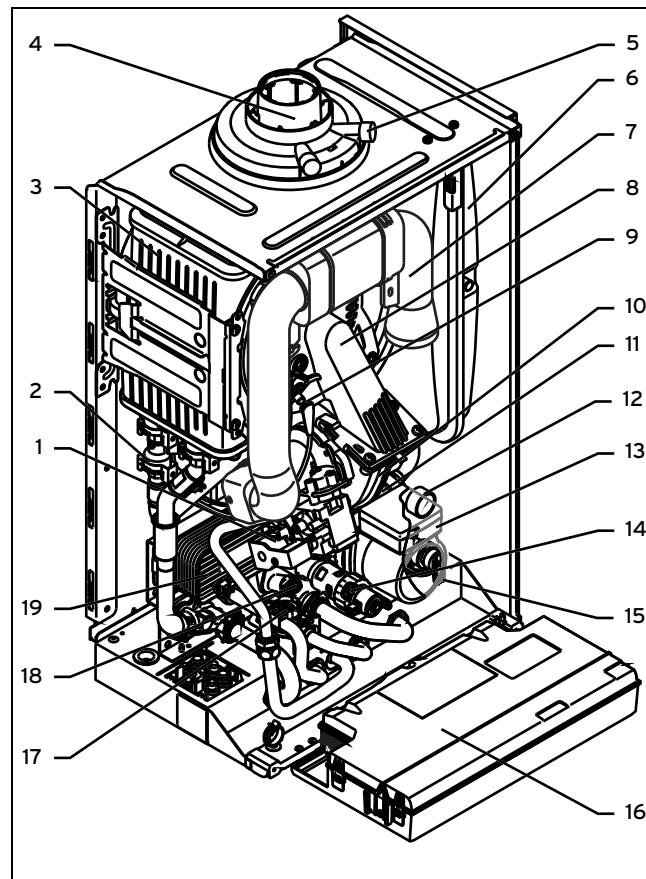





1 Gas valve	11 Automatic air vent
2 Water pressure sensor	12 Pressure gauge
3 Heat exchanger	13 Internal pump
4 Connection for the flue pipe	14 Diverter valve
5 Flue gas analysis point	15 Expansion relief valve
6 Expansion vessel	16 Electronics box
7 Air intake pipe	17 Impeller sensor (hot water)
8 Compact thermal module	18 Bypass valve
9 Ignition electrode	19 Secondary heat exchanger
10 Fan	

3.2 Information on the identification plate

The identification plate is mounted on the underside of the product in the factory.

Information on the identification plate	Meaning
	→ "CE label" section
	Read the instructions.

Information on the identification plate	Meaning
VUW...	Vaillant gas-fired wall-hung boiler for heating and hot water generation
..6/5-3	Calorific value power/product generation equipment
ecoTEC pro	Product description
2H, G20 – 20 mbar (2.0 kPa)	Gas group and gas connection pressure as set at the factory
ww/yyyy	Date of manufacture: Week/year
Cat.	Permissible gas categories
Types	Approved gas-fired units
PMS	Permissible total overpressure in heating mode
PMW	Permissible total overpressure during hot water generation
T _{max.}	Max. flow temperature
ED 92/42	Current efficiency directive fulfilled with 4* rating
V Hz	Mains voltage and mains frequency
W	Max. electrical power consumption
IP	Level of protection
	Heating mode
	Hot water generation
P	Nominal heat output range
Q	Heat input range
D	Nominal hot water draw-off rate
	Proper disposal of the product
	Bar code with serial number, 7th to 16th digit = product article number



Note

Make absolutely sure that the product is compatible with the gas group at the installation site.

3.3 Serial number

The serial number can be found on a plastic label at the bottom of the front casing and on the identification plate.

3.4 CE label



The CE label shows that the products comply with the basic requirements of the applicable directives as stated on the identification plate.

The declaration of conformity can be viewed at the manufacturer's site.

3.5 Energy Saving Trust Endorsed Products



Only the most energy efficient products can carry the 'Energy Saving Trust Endorsed Product' landmark making it easy for consumers to choose products that have met strict energy performance criteria.

Available for: Boilers, Heating controls and chemical inhibitors, the Energy Saving Trust endorsed product landmark gives consumers confidence that a product will cost less to run, help lower energy bills and reduce carbon emissions.

About the Energy Saving Trust

Energy Saving Trust is an independent and impartial organisation that provides trusted energy saving advice to empower millions of people to lead affordable, low energy lifestyles. For more information visit energysavingtrust.org.uk

4 Installation

4.1 Unpacking the product

1. Remove the product from its box.
2. Remove the protective film from all parts of the product.

4.2 Checking the scope of delivery

- ▶ Check that the scope of delivery is complete and intact.

4.2.1 Scope of delivery

Number	Description
1	Heat generator
1	Installation kit containing the following:
1	- Product retainer
1	- Expansion relief valve connector
1	- Hot water connector
4	- Service valve
3	- Bag with small parts
1	Installation template
1	Condensate drain hose
1	Enclosed documentation

4.3 Transporting the product

4.3.1 General

- ▶ Hold the load as close as possible to your body. Do not twist your body – instead, reposition your feet.
- ▶ If the unit is being lifted by two persons, ensure your movements are coordinated during lifting.
- ▶ Avoid bending your upper body – do not lean forwards or to the side.
- ▶ Wear appropriate cut-resistant and non-slip gloves to protect yourself against sharp edges and maintain a safe and secure grip.
- ▶ If required, get somebody to assist you in this.

4 Installation

4.3.2 Unloading the box from the delivery van

- ▶ It is recommended that two people lift the unit together.
- ▶ Lift the box using the straps provided.
- ▶ Use safe lifting techniques – keep your back straight and bend your legs at the knee.
- ▶ Hold the load as close as possible to your body.
- ▶ If the unit is being lifted by two persons, ensure your movements are coordinated during lifting.
- ▶ If required, get somebody to assist you in this.

4.3.3 Transporting the box from the delivery point to the installation site – ground floor

- ▶ It is recommended that two people lift the unit together.
- ▶ Use safe lifting techniques – keep your back straight and bend your legs at the knee.

4.4 Dimensions

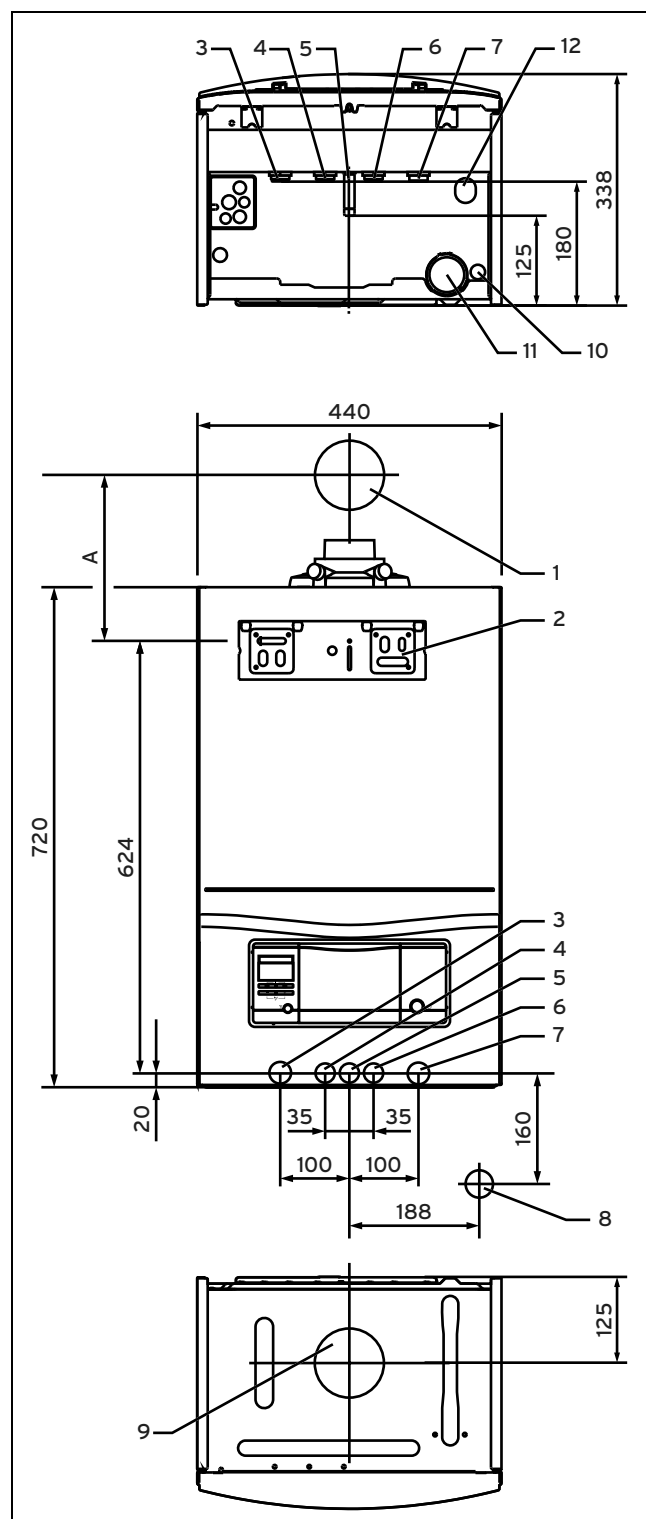

- | | | | |
|---|---|----|--|
| 1 | Flue pipe wall duct | 8 | R1 tundish/condensate trap connection |
| 2 | Product holder | 9 | Flue pipe connection |
| 3 | Heating flow (22 × 1.5 diameter) | 10 | Condensate discharge connection, 19 mm diameter |
| 4 | Hot water connection (15 × 1.5 diameter) | 11 | Condensate trap |
| 5 | Gas connection (15 × 1.5 diameter) | 12 | Drain line/heating expansion relief valve connection, 15 mm diameter |
| 6 | Cold water connection (15 × 1.5 diameter) | | |
| 7 | Heating return (22 × 1.5 diameter) | | |

Consult the installation template that is supplied to find the dimension A.

4.5 Minimum clearances

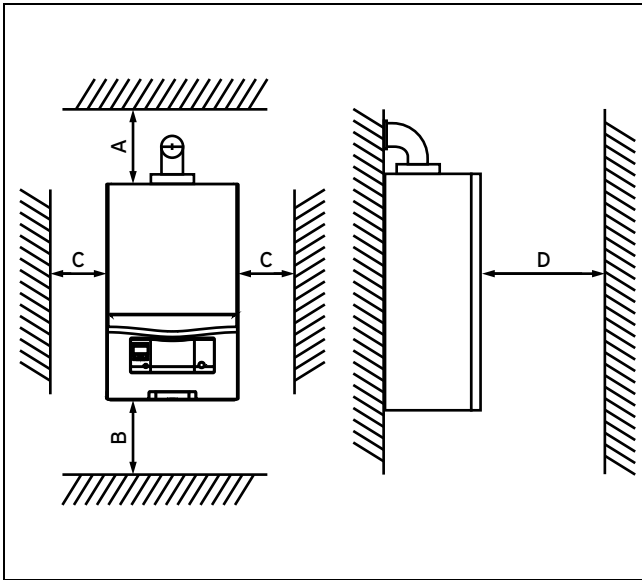

	Minimum clearance
A	165 mm: Air/flue pipe, 60/100 mm diameter 275 mm: Air/flue pipe, 80/125 mm diameter
B	180 mm; optimum approx. 250 mm
C	5 mm; optimum approx. 50 mm
D	500 mm in front of the heat generator to enable easy access for maintenance work (may be provided by an opening door).

4.6 Clearance from combustible components

It is not necessary to maintain a clearance between the product and components made of combustible materials.

4.7 Using the installation template

- ▶ Use the installation template to ascertain the locations at which you need to drill holes and make breakthroughs.

4.8 Wall-mounting the product

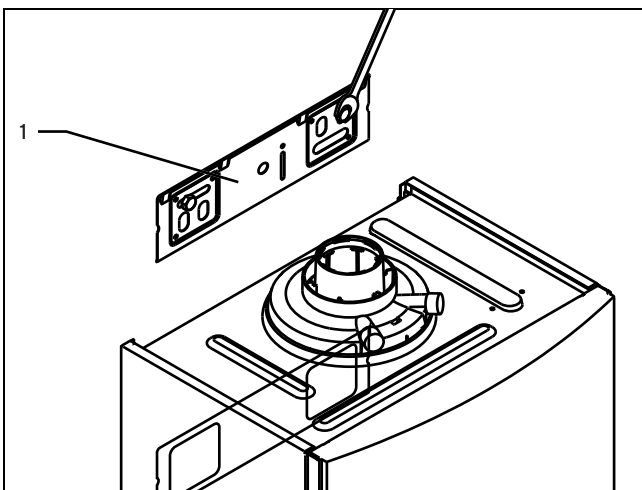

1. Check whether the wall has sufficient load-bearing capacity to bear the operational weight of the product.

2. Check if the supplied fixing material may be used for the wall.

Conditions: The load-bearing capacity of the wall is sufficient, The fixing material may be used for the wall

- ▶ Wall-mount the product as described.
- ▶ Install the product bracket (1) on the wall.
- ▶ Hang the product on the product bracket from above using the suspension bracket.

Conditions: The fixing material may not be used for the wall

- ▶ Wall-mount the product as described using the permitted fixing material provided on-site.

4.9 Removing the front casing

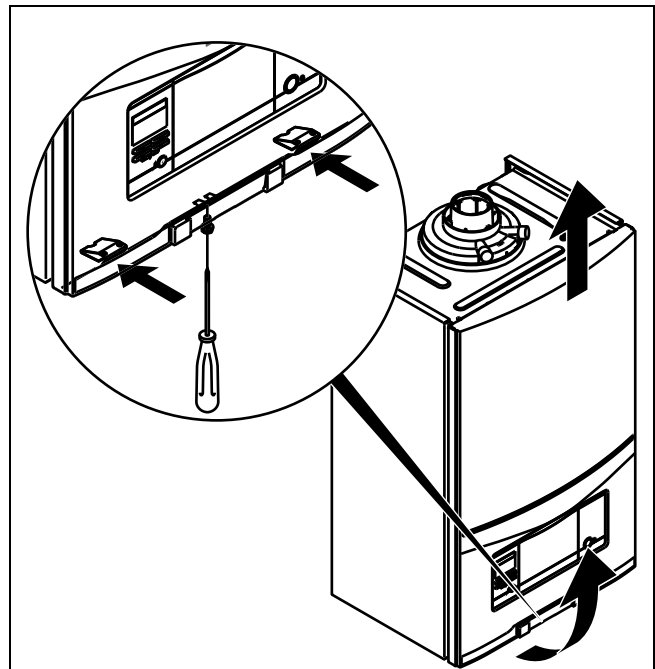

- ▶ Remove the front casing as shown in the illustration.

5 Installation

4.10 Removing the side section

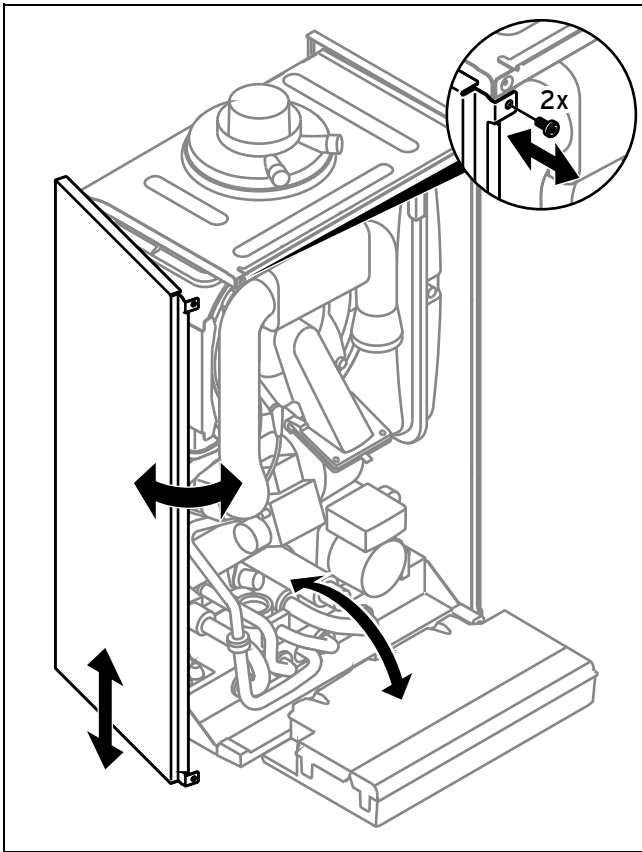

Caution.

Risk of material damage caused by mechanical deformation.

Removing both side sections may cause mechanical distortion in the product, which may cause damage to the piping, for example, and potentially result in leaks.

- ▶ Always only remove one side section – never both side sections at the same time.

- ▶ Remove the side section as shown in the illustration.

5 Installation



Danger!

Risk of scalding and/or risk of material damage due to incorrect installation leading to escaping water.

Stresses in supply lines can cause leaks.

- ▶ Install the supply lines without tension.

Caution.

Risk of material damage due to the gas leak-tightness test.

At a test pressure of >11 kPa (110 mbar), gas leak-tightness tests may cause damage to the gas valve.

- ▶ If, during gas leak-tightness tests, you also place the gas lines and the gas valve in the product under pressure, use a max. test pressure of 11 kPa (110 mbar).
- ▶ If you cannot limit the test pressure to 11 kPa (110 mbar), close any gas isolator cocks that are installed upstream from the product before you carry out the gas leak-tightness test.
- ▶ If, during gas leak-tightness tests, you have closed the gas isolator cock that is installed upstream of the product, relieve the gas line pressure before you open this gas isolator cock.

Caution.

Risk of material damage due to corrosion.

If non-diffusion-tight plastic pipes are used in the heating installation, this may cause air to enter the heating water and corrosion of the heat generation circuit and the heat generator.

- ▶ If using non-diffusion-tight plastic pipes in the heating installation, partition the system by installing an external heat exchanger between the heat generator and the heating installation.

Caution.

Risk of material damage due to heat transfer during soldering.

- ▶ Do not solder the connection pieces if the connection pieces are screwed to the service valves.

5.1 Installation requirements

5.1.1 Information on liquid gas operation

In the as-delivered condition, the product is preset for operation with the gas group indicated on the identification plate.

If you have a product that has been preset for operation with natural gas, you must convert it to run on liquid gas. You will need a conversion kit for this. The conversion procedure is described in the manual supplied with the conversion kit.

5.1.2 Purging the liquid gas tank

If the liquid gas tank is not purged properly, this may result in ignition problems.

- ▶ Ensure that the liquid gas tank has been purged properly before installing the product.
- ▶ If required, contact the filler or the liquid gas supplier.

5.1.3 Using the correct type of liquid gas

Using the incorrect type of liquid gas may cause fault shut-downs in the product. Ignition and combustion noise may occur in the product.

- ▶ Only use the gases listed on the identification plate.

5.1.4 Required preliminary work

1. Install a stop cock in the gas line.
2. Make sure that the existing gas meter is capable of passing the rate of gas supply required.
3. Check that the volumetric capacity of the expansion vessel is sufficient for the system volume.

Conditions: The volume of the installed expansion vessel is insufficient

- ▶ Install an additional expansion vessel, connected as close to the product as possible, in the heating return.

Conditions: External expansion vessel installed

- ▶ Install a non-return valve in the product outlet (heating flow) or decommission the internal expansion vessel in order to prevent the warm start function from being increasingly activated due to backflow.
4. Install a tundish with siphon for the condensate discharge and the exhaust pipe on the expansion relief valve. Lay as short a drain line as possible, at a downward gradient away from the tundish.
 5. Insulate bare pipes exposed to environmental influences to protect them from frost using suitable insulating material.

5.2 Installing the gas connection

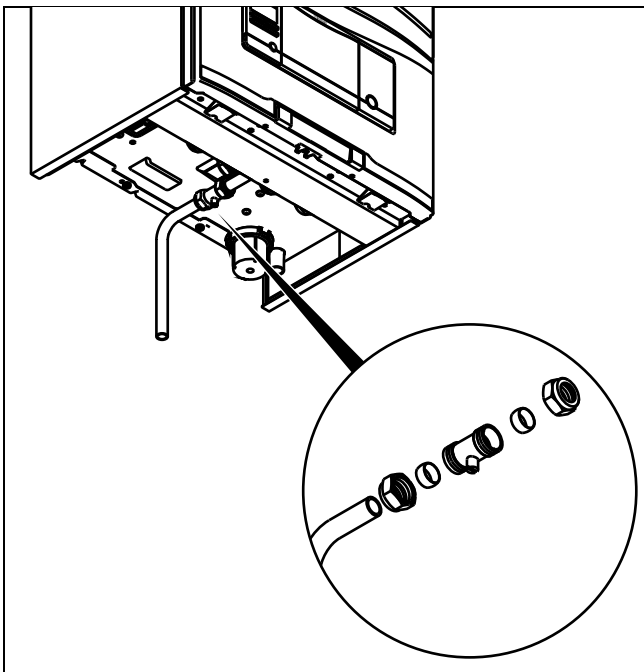

1. Install the gas line in accordance with the recognised rules of technology.
2. Connect the product to the gas line as shown in accordance with the recognised rules of good engineering practice.
3. Remove the residues from the gas line by blowing through the gas line beforehand.
4. Purge the gas line before start-up.
5. Check the gas line for leak-tightness.

5.3 Installing the hot and cold water connection

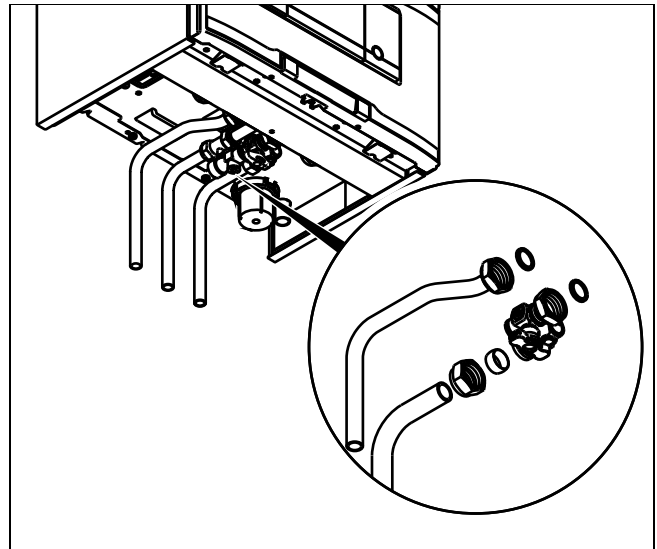

1. Make the water connections as shown in accordance with the relevant standards.
2. Ensure correct water pressure and flow requirements and that any expansion can be accommodated with the cold supply pipe work.

5.4 Connecting the heating flow and heating return

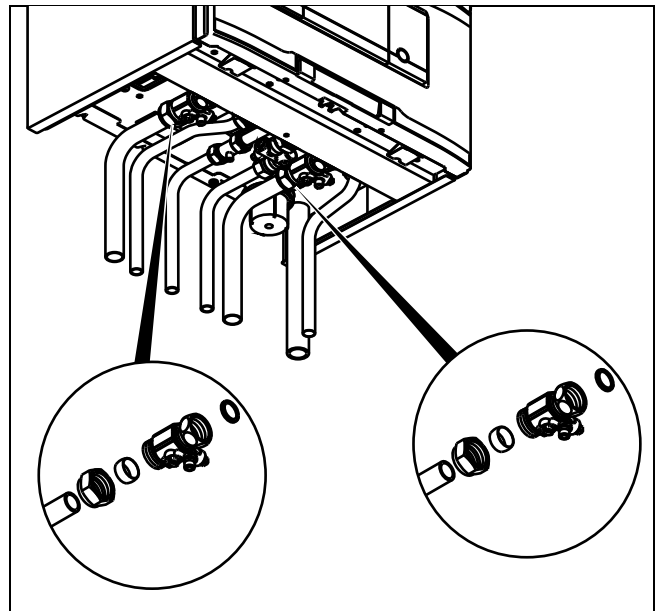

- ▶ Make the heating connections as shown in accordance with the relevant standards.

5 Installation

5.5 Connecting the condensate drain pipework



Danger!

Risk of death from escaping flue gases!

The condensate drain pipework for the siphon must not be connected tightly to waste-water piping because, otherwise, the internal condensate trap may be drained fully and flue gas may escape.

- ▶ Do not connect the condensate drain pipework tightly to the waste-water piping.

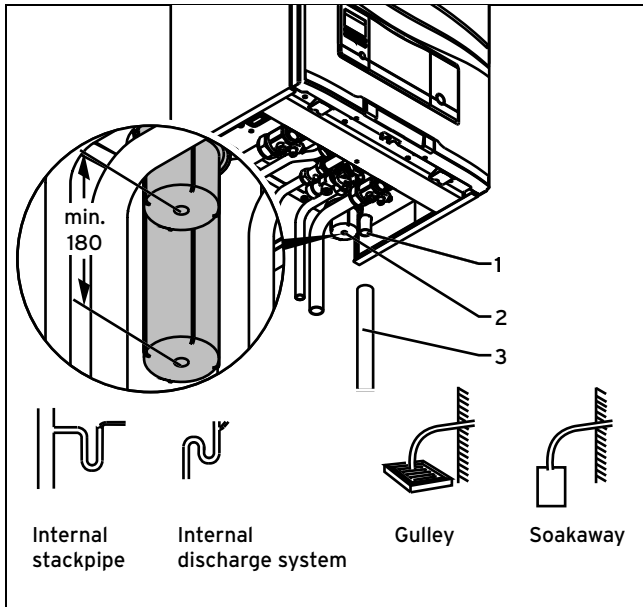

The product is equipped with a condensate trap (2). (The filling height is 145 mm). The condensate trap collects the condensate that has formed in a vessel with a capacity of approximately 200 ml, and intermittently releases the contents into the discharge pipe. This minimises the risk of the discharge pipe freezing.

- ▶ Connect the condensate discharge (1) to condensate drain pipework (3) which has a minimum internal diameter of 19 mm (22 mm outside diameter for all external pipes) and is made from an acid-resistant material (e.g. plastic overflow pipe).
 - The condensate discharge pipework must have a continuous fall (45 mm per metre) and should whenever possible terminate at a suitable discharge point within the heated envelope of the building that will remain frost free under long periods of low external temperatures.
- ▶ During installation remove all burrs from inside of cut pipe work and avoid excessive adhesive which may trap small pockets of water close to the pipe wall which can freeze and build into a larger ice plug.
- ▶ As with other pipe work insulate the condensate discharge pipe to minimise any risk of freezing and beware when crossing cavities that the fall is maintained and the pipe sleeved.
- ▶ Ensure that the condensate drain pipework terminates in a suitable location. Further information can be obtained from BS 6798 Specification for installation of gas-fired boilers of rated input not exceeding 70 kW net.

- ▶ Leave an installation space of at least 180 mm beneath the condensate trap.

5.6 Installing the discharge pipe on the expansion relief valve

1. Install the discharge pipe for the expansion relief valve so that it does not interfere with the removal and fitting of the lower section of the condensate trap.

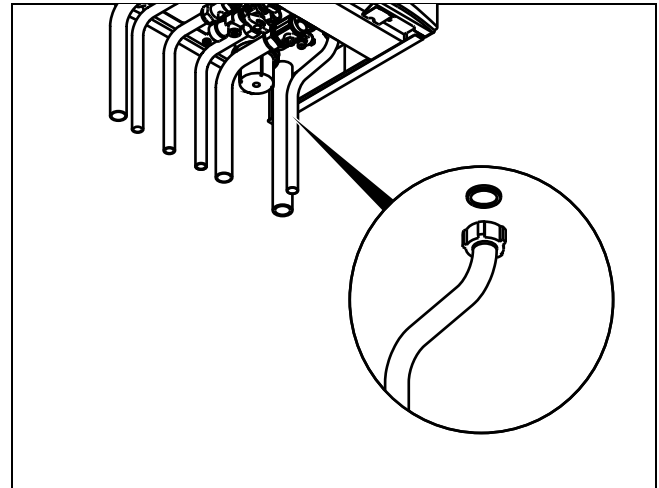

2. Install the discharge pipe as shown (do not shorten).
3. Make sure that the end of the pipe is visible.
4. Ensure that discharged water or steam cannot cause injury to persons or damage to electronic components.
5. Ensure the discharge pipe work is installed, routed and terminated correctly to minimise the risk of freezing up.

5.7 Flue gas installation

5.7.1 Installing and connecting the flue pipe

1. You can find out which flue pipes may be used by consulting the enclosed flue pipe installation manual.
2. Observe the information on positioning the opening for the flue pipe. This information can be found in the appendix.

Conditions: Installation in damp rooms

- ▶ You must connect the product to a room-sealed air/flue gas installation. The combustion air must not be taken from the installation site.



Caution.

Risk of poisoning due to escaping flue gas.

Mineral-oil-based greases can damage the seals.

- ▶ Instead of grease, use only water or commercially available soft soap to aid installation.

3. Install the flue pipe using the installation manual.

5.7.2 Replacing the connection piece for the air/flue pipe as required

1. Replace the connection piece for the air/flue pipe as required. The product-specific standard equipment is listed under Technical data.
2. Remove the connection piece for the air/flue pipe – this is installed at the factory. (→ Page 15)
3. **Alternatives 1 / 2**
 - ▶ If required, install the connection piece for the air/flue pipe, 80/125 mm diameter. (→ Page 15)
3. **Alternatives 2 / 2**
 - ▶ If required, install the connection piece with offset for the air/flue pipe, 60/100 mm diameter. (→ Page 15)

5.7.2.1 Removing the connection piece for the air/flue pipe

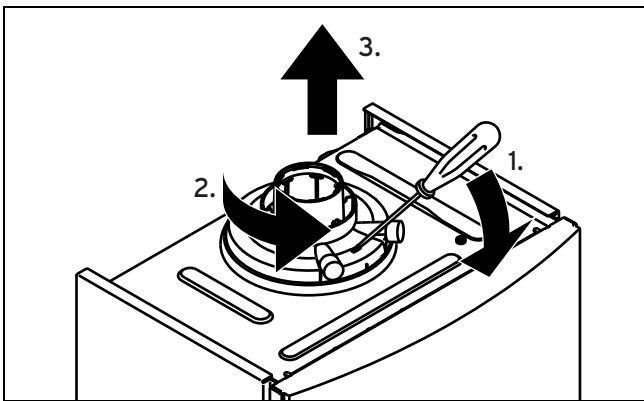

1. Insert a screwdriver into the slot between the measuring stub pipes.
2. Press the screwdriver carefully down (1.).
3. Turn the connection piece anticlockwise (2.) as far as it will go and then remove it by pulling it upwards (3.).

5.7.2.2 Installing the connection piece for the air/flue pipe, 80/125 mm diameter

1. Remove the connection piece for the air/flue pipe – this is installed at the factory. (→ Page 15)
2. Insert the alternative connection piece. In doing so, pay attention to the latching lugs.
3. Turn the connection piece clockwise until it clicks into position.

5.7.2.3 Installing the connection piece with offset for the air/flue pipe, 60/100 mm diameter

1. Remove the connection piece for the air/flue pipe – this is installed at the factory. (→ Page 15)

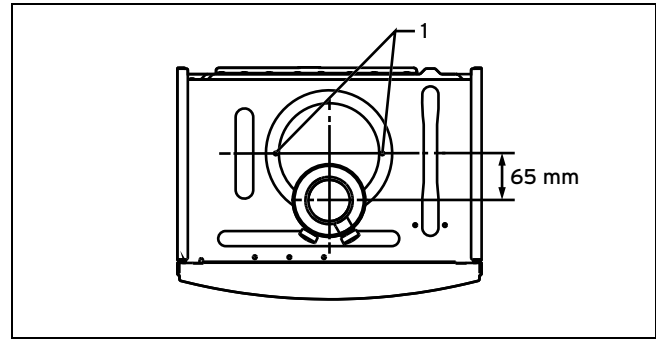

2. Insert the alternative connection piece with offset towards the front.
3. Use two screws (1) to secure the connection piece to the product.

5.8 Electrical installation

The electrical installation must only be carried out by a qualified electrician.



Danger!

Risk of death from electric shock!

Since mains connection terminals L and N remain live even if the on/off button is switched off:

- ▶ Switch off the power supply.
- ▶ Secure the power supply against being switched on again.

5.8.1 Opening the electronics box

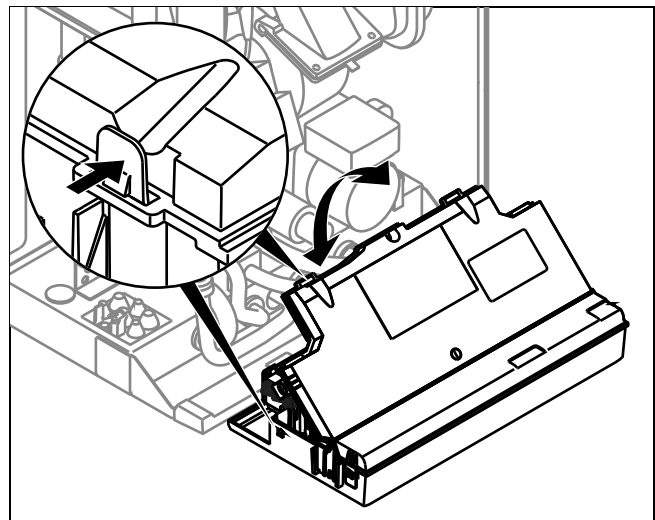

- ▶ Open the electronics box as shown in the illustration.

5.8.2 Carrying out the wiring



Caution.

Risk of material damage caused by incorrect installation.

Mains voltage at incorrect terminals and plug terminals may destroy the electronics.

- ▶ Do not connect any mains voltage to the eBUS terminals (+/-).

5 Installation

- ▶ Only connect the mains connection cable to the terminals marked for the purpose.

1. Route the supply lines of the components to be connected through the cable duct provided on the underside of the product on the left.
2. Use strain reliefs.
3. Shorten the supply lines as necessary.

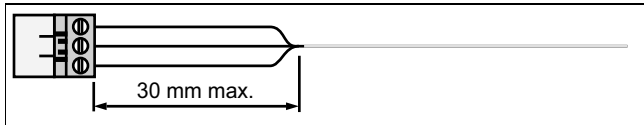

4. To prevent short circuits if a strand accidentally comes loose, only strip the outer sheathing of flexible lines to a maximum of 30 mm.
5. Ensure the inner conductor insulation is not damaged when stripping the outer sheathing.
6. Only strip inner conductors just enough to establish good, sound connections.
7. To avoid short circuits resulting from loose individual wires, fit conductor end sleeves on the stripped ends of the conductors.
8. Screw the respective plug to the supply line.
9. Check whether all conductors are sitting mechanically securely in the terminals of the plug. Remedy this if necessary.
10. Plug the plug into the associated PCB slot; see the connection diagram in the appendix.

5.8.3 Establishing the power supply



Caution.

Risk of material damage due to high connected voltage.

At mains voltages greater than 253 V, electronic components may be damaged.

- ▶ Make sure that the rated voltage of the mains is 230 V.

1. Make sure that the nominal mains voltage is 230 V.
2. Provide one common electricity supply for the boiler and for the corresponding controller:
 - Power supply: Single-phase, 230 V, 50 Hz
 - Fuse protection: ≤ 3 A
3. Open the electronics box. (→ Page 15)
4. Connect the product using a fixed connection and a partition with a contact opening of at least 3 mm (e.g. fuses or power switches).
5. Route a three-core mains connection cable that complies with the relevant standards through the cable duct and into the product.
 - Mains connection line: Flexible line
6. Carry out the wiring. (→ Page 15)
7. Remove the supplied plug from the bracket in the electronics box and screw the plug onto the mains connection cable.
8. Close the electronics box.
9. Make sure that access to the mains connection is always available and is not covered or blocked.

5.8.4 Installing the product in a moist environment



Danger!

Risk of death from electric shock!

If you install the product in a room with high levels of moisture, e.g. a bathroom, observe the nationally recognised technical standards for electrical installations. If you use the factory-installed connection cable, if installed, with an earthed plug, there is a risk of death from electric shock.

- ▶ Never use the factory-installed connection cable with earthed plug when installing the product in a moist environment.
- ▶ Connect the product using a fixed connection and a partition with a contact opening of at least 3 mm (e.g. fuses or power switches).
- ▶ Use a flexible line for the mains connection line, which is routed through the cable duct into the product.

1. Open the electronics box. (→ Page 15)
2. Detach the plug from the PCB slot for the mains connection (X1).
3. Unscrew the plug of the factory-installed mains connection cable, if installed.
4. Instead of the factory-installed mains connection cable, if installed, use a suitable three-core mains connection cable which complies with the relevant standards.
5. Carry out the wiring. (→ Page 15)
6. Close the electronics box.
7. Observe the flue-gas connection that is required on a room-sealed air/flue gas installation. (→ Page 14)

5.8.5 Connecting controllers to the electronic system

1. Install the controller if necessary.
2. Open the electronics box. (→ Page 15)
3. Carry out the wiring. (→ Page 15)
4. Observe the connection diagram in the appendix.

Conditions: Connecting a weather compensator or a room temperature controller via eBUS

- ▶ Connect the controller to the eBUS connection.
- ▶ Bridge the 24 V = RT connection (X100 or X106), if there is not already a bridge.

Conditions: Connecting a low-voltage controller (24 V)

- ▶ Remove the bridge and connect the controller to the 24 V = RT connection (X100 or X106).

Conditions: Connecting 230 volt controller

- ▶ Connect the switched live supply with the terminal marked RT at X1 (beside the LNPE connections) then remove the link at X100 (do NOT connect 230 volt to any other terminal than the RT connection).

Conditions: Connecting a limit thermostat for underfloor heating

- ▶ Remove the bridge and connect the limit thermostat to the **Burner off** connection.
- 5. Close the electronics box.
- 6. For multi-circuit controllers, change **D.018** from **Eco** (intermittently operating pump) to **Comfort** (continuously operating pump). (→ Page 23)

5.8.6 Connecting additional components via VR 40 ("2 in 7" multi-functional module)

1. Install the components in accordance with the respective instructions.

Conditions: Components connected to relay 1

- ▶ Activate **D.027**. (→ Page 23)

Conditions: Components connected to relay 2

- ▶ Activate **D.028**. (→ Page 23)

5.8.7 Actuating the circulation pump according to requirements

1. Carry out the wiring.
2. Connect the supply line for the external button using terminals 1 (0) and 6 (functional drawing) on the X41 edge connector, which is supplied with the controller.
3. Plug the edge connector into the PCB slot X41.

6 Operation

6.1 Operating concept

The operating concept and the read-off and setting facilities of the operator level are described in the operating instructions.

An overview of the read-off and setting options in the installer level can be found in the section "Overview of the installer level". (→ Page 17)

6.2 Installer level overview

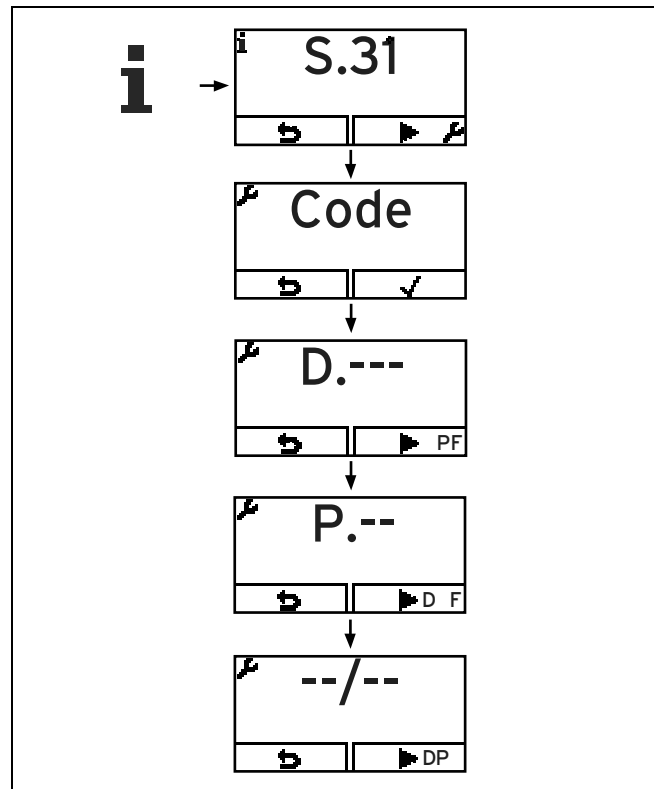

6.3 Calling up the installer level

1. Only call up the installer level if you are a competent person.
2. Press and ("i") at the same time.
 - ◀ **S.xx** appears in the display (current unit status).
3. Press to access the installer level.
 - ◀ **Code** and **--** appear in the display.
4. Set the value **17** (code) and confirm by pressing .
5. Press to access the check programmes (**P**) and the fault codes (**F**) and to return to the diagnostics codes (**D**).
6. Use or to set the required value and confirm by pressing .
7. Confirm by pressing .
8. Press to cancel a setting or exit the installer level.

6.4 Live Monitor (status codes)

Menu → Live Monitor

Status codes in the display provide information on the product's current operating status.

Status codes – Overview (→ Page 34)

7 Start-up

6.5 Setting the hot water temperature

Conditions: Water hardness: > 3.57 mol/m³



Danger!

Risk of death from Legionella.

Legionella multiply at temperatures below 60 °C.

- ▶ Ensure that the operator is familiar with all of the Anti-legionella measures in order to comply with the applicable regulations regarding legionella prevention.

- ▶ Set the hot water temperature to a maximum of 50 °C.

7 Start-up

7.1 Carrying out the initial start-up

Initial start-up must be carried out by a customer service technician or an authorised competent person using the commissioning checklist. The commissioning checklist in the appendix (→ Page 40) of the installation instructions must be filled in and stored carefully along with the unit's documentation.

- ▶ Carry out the start-up procedure using the commissioning checklist in the appendix.
- ▶ Fill in and sign the commissioning checklist.

7.2 Switching the product on and off

- ▶ Press the on/off button on the product.
 - ◀ The basic display appears on the display.

7.3 Using check programmes

Call up the installer level + 1x

Display	Meaning
P.00	<p>Purging check programme: The internal pump is cyclically actuated. The heating circuit and the hot water circuit are purged via the automatic air vent (the cap of the automatic air vent must be released).</p> <p>1 x : Start heating circuit purging 2 x : Start hot water circuit purging 3 x : Restart heating circuit purging 1 x (Cancel): End purge programme</p> <p>Note The purge programme runs for 7.5 min per circuit and then terminates. Purging the heating circuit: Diverter valve in heating position, actuation of internal pump for 9 cycles: 30 sec. on, 20 sec. off. Display: Active heating circuit. Purging the hot water circuit: After the above-mentioned cycles have run or the right-hand selection button has been pressed again: Diverter valve in the hot water position, actuation of the internal pump as above. Display: Active hot water circuit.</p>

Display	Meaning
P.01	Maximum load check programme: After successful ignition, the product is operated at maximum heat input.
P.02	Minimum load check programme: After successful ignition, the product is operated at minimum heat input.
P.06	Filling mode check programme: The diverter valve is moved to the mid-position. The burner and pump are switched off (to fill or drain the product).

7.4 Checking and treating the heating water/filling and supplementary water



Caution.

Risk of material damage due to poor-quality heating water

- ▶ Ensure that the heating water is of sufficient quality.

- ▶ Before filling or topping up the system, check the quality of the heating water.

Checking the quality of the heating water

- ▶ Remove a little water from the heating circuit.
- ▶ Check the appearance of the heating water.
- ▶ If you ascertain that it contains sedimentary materials, you must desludge the system.
- ▶ Use a magnetic rod to check whether it contains magnetite (iron oxide).
- ▶ If you ascertain that it contains magnetite, clean the system and apply suitable corrosion-protection measures, or fit a magnet filter.
- ▶ Check the pH value of the removed water at 25 °C.
- ▶ If the value is below 8.2 or above 10.0, clean the system and treat the heating water.
- ▶ Ensure that oxygen cannot get into the heating water.
- ▶ Ensure that oxygen cannot get into the heating water. (→ Page 23)

Checking the filling and supplementary water

- ▶ Before filling the system, measure the hardness of the filling and supplementary water.

Treating the filling and supplementary water

- ▶ Observe all applicable national regulations and technical standards when treating the filling and supplementary water.

Provided the national regulations and technical standards do not stipulate more stringent requirements, the following applies:

You must treat the heating water in the following cases:

- If the entire filling and supplementary water quantity during the operating life of the system exceeds three times the nominal volume of the heating installation, or
- If the guideline values listed in the following table are not met, or
- If the pH value of the heating water is less than 8.2 or more than 10.0.

Total heating output	Water hardness at specific system volume ¹⁾					
	≤ 20 l/kW		> 20 l/kW ≤ 50 l/kW		> 50 l/kW	
kW	ppm CaCO ₃	mol/m ³	ppm CaCO ₃	mol/m ³	ppm CaCO ₃	mol/m ³
< 50	< 300	< 3	200	2	2	0.02
> 50 to ≤ 200	200	2	150	1.5	2	0.02
> 200 to ≤ 600	150	1.5	2	0.02	2	0.02
> 600	2	0.02	2	0.02	2	0.02

1) Nominal capacity in litres/heating output; in the case of multi-boiler systems, the smallest single heating output is to be used.



Caution.

Risk of material damage if the heating water is treated with unsuitable additives.

Unsuitable additives may cause changes in the components, noises in heating mode and possibly subsequent damage.

- ▶ Do not use any unsuitable frost and corrosion protection agents, biocides or sealants.

No incompatibility with our products has been detected to date with proper use of the following additives.

- ▶ When using additives, follow the manufacturer's instructions without exception.

We accept no liability for the compatibility of any additive or its effectiveness in the rest of the heating system.

Additives for cleaning measures (subsequent flushing required)

- Fernox F3
- Sentinel X 300
- Sentinel X 400

Additives intended to remain permanently in the system

- Fernox F1
- Fernox F2
- Sentinel X 100
- Sentinel X 200

Additives for frost protection intended to remain permanently in the system

- Fernox Antifreeze Alphi 11
- Sentinel X 500

- ▶ If you have used the above-mentioned additives, inform the operator about the measures required.
- ▶ Inform the operator about the measures required for frost protection.

7.5 Preventing low water pressure

To ensure that the heating installation operates smoothly, the indicator on the pressure gauge must point to the upper half of the grey area or to the middle of the bar graph display in the display (marked by the dashed limit values) when the heating installation is cold. This corresponds to a filling pressure of between 0.1 MPa and 0.2 MPa (1.0 bar and 2.0 bar).

If the heating installation extends over several storeys, higher filling pressures may be required to avoid air entering the heating installation.

If the filling pressure falls below 0.08 MPa (0.8 bar), the product indicates low pressure by displaying a flashing pressure value. If the filling pressure falls below 0.05 MPa (0.5 bar), the product switches off. The display shows **F.22**.

- ▶ Top up the heating water to start the product up again.

The pressure value flashes in the display until a pressure of 0.11 MPa (1.1 bar) or higher has been reached.

7.6 Flushing the heating installation for the first time ("cold")



Note

The complete heating system must be flushed at least twice: Once with cold water and once with hot water in accordance with the following instructions.

1. Check whether all thermostatic radiator valves and both service valves on the product are open.
2. Connect a hose to the drain valve that is located at the lowest position in the heating system.
3. Open the radiator valves and the drain valves so that the water can drain quickly. Start at the next point in the system and open the purging valves on the radiators so that the contaminated water can completely drain.
4. Close the drain cocks.
5. Refill the heating system with water.
6. Check that the expansion relief valve of the heating system is functioning correctly by turning the handle on the valve.
7. Check the pressure in the heating system and top up with water if necessary.
8. Close the filling valve and the cold water valve.

7.7 Filling the heating installation

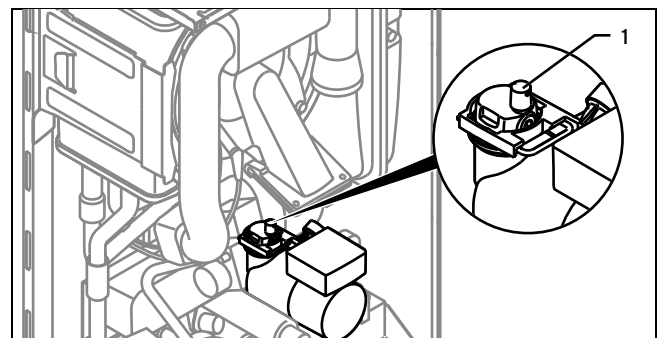

1. Flush the heating installation through.
2. Undo the cap of the automatic air vent (**1**) by one to two rotations and leave it open, as the product purges itself via the automatic air vent even in continuous mode.

7 Start-up

3. Select the check programme **P.06**.
 - ◁ The diverter valve moves to the mid-position, the pumps do not run and the product does not switch to heating mode.
4. Observe the information on treating heating water. (→ Page 18)
5. Connect the filling and drainage tap in the heating installation to a heating water supply, if possible with the cold water valve, in accordance with the relevant standards.
6. Open the heating water supply.
7. Open all radiator valves (thermostatic radiator valves) of the heating installation.
8. If necessary, check that both service valves on the product are open.
9. Slowly open the filling and drainage tap so that the water flows into the heating system.
10. Purge the lowest radiator until water flows out of the purging valve without bubbles.
11. Purge all other radiators until the entire heating system has been filled with water.
12. Close all purging valves.
13. Monitor the rising filling pressure in the heating installation.
14. Fill with water until the required filling pressure is reached.
15. Close the filling and drainage tap and the cold water valve.
16. Check all connections and the entire system for leaks.

7.8 Purging the heating installation

1. Select the check programme **P.00**.
 - ◁ The product does not start up, the internal pump operates intermittently and purges either the heating circuit or the hot water circuit.
 - ◁ The display shows the filling pressure of the heating installation.
2. Make sure that the filling pressure of the heating installation does not fall below the minimum filling pressure.
 - $\geq 0.08 \text{ MPa}$ ($\geq 0.80 \text{ bar}$)
 - ◁ At the end of the filling procedure, the filling pressure of the heating installation should be at least 0.02 MPa (0.2 bar) above the counter-pressure of the expansion vessel ("Exp") ($P_{\text{Installation}} \geq P_{\text{Exp}} + 0.02 \text{ MPa}$ (0.2 bar)).
3. If there is still too much air in the heating installation at the end of the check programme **P.00**, repeat the check programme.

7.9 Filling and purging the hot water system

1. Open the cold water stop valve on the product.
2. Fill the hot water system by opening all the hot water draw-off valves until water escapes.

7.10 Filling the condensate trap

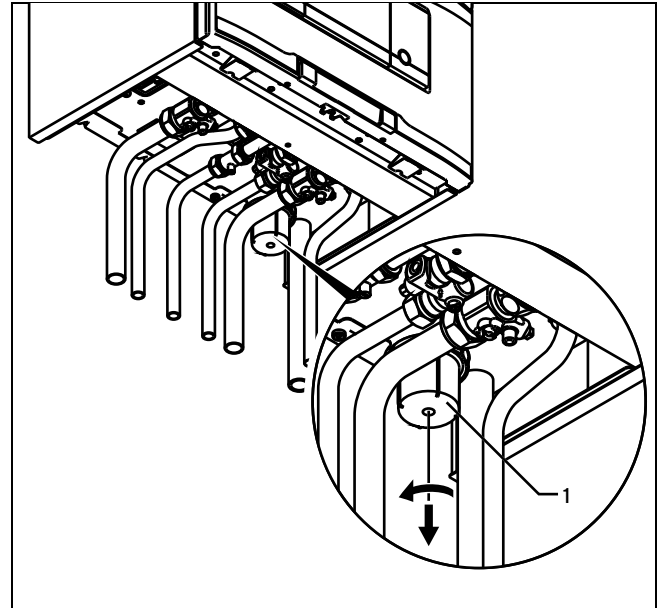

1. Remove the lower section from the condensate trap (1).
2. Fill the lower section with water up to 10 mm below the upper edge.
3. Attach the lower section to the condensate trap.

7.11 Gas ratio setting

7.11.1 Checking the factory-set gas ratio setting



Caution.

Risk of material damage caused by making unauthorised settings.

- ▶ Never modify the factory setting of the gas pressure regulator of the gas valve.

- ▶ Before you start up the product, compare the gas group information on the identification plate with the gas group available at the installation site.

Conditions: The product design is not compatible with the local gas group

Only Vaillant Service Solutions may perform a gas conversion.

If a gas conversion to liquid gas has been carried out, the smallest possible partial load is higher than is shown on the display. The correct values can be found in the Technical data in the appendix.

- ▶ Call Vaillant Service Solutions (0330 1003 143).
- ▶ Do not start up the product.

Conditions: The product design is compatible with the local gas group

- ▶ Proceed as described below.

7.11.2 Checking the leak-tightness of the flue gas system and for flue gas recirculation

1. Check the integrity of the flue gas system.
2. If the flue gas system is longer than 2 m, we urgently recommend that you test the system for flue gas recirculation as described below.
3. Use the air analysis point to check for flue gas recirculation.
4. Use the flue gas measuring instrument.
5. If you discover CO or CO₂ in the fresh air, search for a leak in the flue gas system or for the flue gas recirculation.
6. Eliminate the damage.
7. Repeat the above-mentioned test to determine if the fresh air contains CO or CO₂.
8. If you cannot eliminate the damage, you must not start up the boiler.

7.11.3 Checking the gas flow rate

The boiler is fitted with a multifunctional automatic gas valve which ensures that the precise air/gas ratio is provided under all operating conditions. The gas flow rate has been set during production and does not require adjustment. With the front casing fitted check the gas flow rate of the boiler as follows:

- ▶ Start up the product with the check programme **P.01**.
- ▶ In addition, ensure that maximum heat can be dissipated into the heating system by turning up the room thermostat.
- ▶ Wait at least 5 minutes until the boiler has reached its operating temperature.
- ▶ Ensure that all other gas appliances in the property are turned off.
- ▶ Measure the gas flow rate at the gas meter.
- ▶ Compare the measured values with the corresponding values in the table.

Nominal value for the net heat supply in kW in accordance with BS EN 483	H gas in m ³ /h			P gas in kg/h		
	Nom.	+5%	-10%	Nom.	+5%	-10%
24	2,61	2,74	2,35	1,92	2,02	1,73
28	3,10	3,26	2,79	2,25	2,36	2,03
30	3,27	3,43	2,94	2,40	2,52	2,16

Conditions: Gas flow rate not in the permissible range

- ▶ Check all of the piping and ensure that the gas flow rates are correct.
- ▶ Only put the product into operation once the gas flow rates have been corrected.

Conditions: Gas flow rate in the permissible range

- ▶ End the check programme **P.01**.
- ▶ Allow the boiler to cool down by allowing pump overrun to operate for a minimum of two minutes.
- ▶ Record the boiler maximum gas flow rate onto the Benchmark gas boiler commissioning checklist.

7.11.4 Checking the gas flow pressure

1. Ensure that the gas inlet working pressure can be obtained with all other gas appliances in the property working.
2. Close the gas isolator cock.

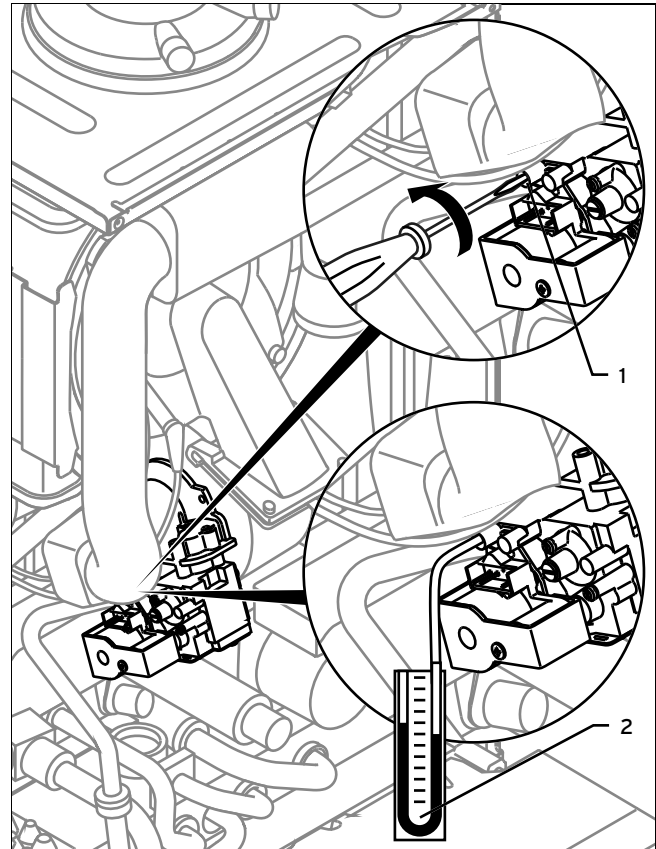

3. Use a screwdriver to undo the measuring nipple screw (1) (lower screw) at the gas valve.
4. Connect a pressure gauge (2) to the measuring nipple (1).
5. Open the gas isolator cock.
6. Start up the product with the check programme **P.01**.
7. In addition, ensure that maximum heat can be dissipated into the heating system by turning up the room thermostat.
8. With the boiler operating at full load check that the gas inlet working pressure at the reference test point complies with the requirements.
 - Permissible gas flow pressure for operation with G20 natural gas: 1.3 ... 2.3 kPa (13.0 ... 23.0 mbar)
 - Permissible gas flow pressure for operation with G31 liquid gas: 2.3 ... 4.3 kPa (23.0 ... 43.0 mbar)
9. Should the pressure recorded at the reference test point in the boiler be lower than indicated check if there is any blockage in the pipework or if the pipework is undersized.

7 Start-up

Conditions: Gas flow pressure not in the permissible range



Caution.

Risk of material damage and operating faults caused by incorrect gas connection pressure.

If the gas connection pressure lies outside the permissible range, this can cause operating faults in and damage to the product.

- ▶ Do not make any adjustments to the product.
- ▶ Do not start up the product.

- ▶ If you cannot correct the failure, notify the gas supply company and proceed as follows:
- ▶ End the check programme **P.01**.
- ▶ Allow the boiler to cool down by allowing pump overrun to operate for a minimum of two minutes.
- ▶ Close the gas isolator cock.
- ▶ Remove the pressure gauge and retighten the sealing screw **(1)** for the measuring nipple.
- ▶ Open the gas isolator cock.
- ▶ Check the measuring nipple for gas tightness.
- ▶ Close the gas isolator cock.
- ▶ Install the front casing.
- ▶ Disconnect the product from the power mains.
- ▶ You must not start up the boiler.

Conditions: Gas flow pressure in the permissible range

- ▶ End the check programme **P.01**.
- ▶ Allow the boiler to cool down allowing pump overrun to operate for a minimum of two minutes.
- ▶ Close the gas isolator cock.
- ▶ Remove the pressure gauge and retighten the sealing screw **(1)** for the measuring nipple.
- ▶ Open the gas isolator cock.
- ▶ Check the measuring nipple for gas tightness.
- ▶ Install the front casing.
- ▶ Reset boiler controls for normal operation.
- ▶ Record the appliance gas inlet working pressure (kPa resp. mbar) in the Benchmark gas boiler commissioning checklist.

7.11.5 Checking the CO₂ content and, if necessary, adjusting it (air index setting)

1. Start up the product with the check programme **P.01**.
2. Wait at least five minutes until the product reaches its operating temperature.
3. Measure the CO₂ and CO/CO₂ content at the flue gas analysis point.
4. Compare the measured value with the corresponding value in the table.

Settings	Unit	G20 natural gas	G31 liquid gas
CO ₂ after 5 minutes in full load mode with front casing closed	Vol.-%	9.2 ± 1.0	10.4 ± 0.5

Settings	Unit	G20 natural gas	G31 liquid gas
CO ₂ after 5 minutes in full load mode with front casing removed	Vol.-%	9.0 ± 1.0	10.2 ± 0.5
Set for Wobbe index W _o	kWh/m ³	14.09	21.34
O ₂ after 5 minutes in full load mode with front casing closed	Vol.-%	4.5 ± 1.8	5.1 ± 0.8
CO value with full load	ppm	≤ 250	≤ 250
CO/CO ₂		≤ 0.0031	≤ 0.0026

Conditions: The CO₂ content must be adjusted

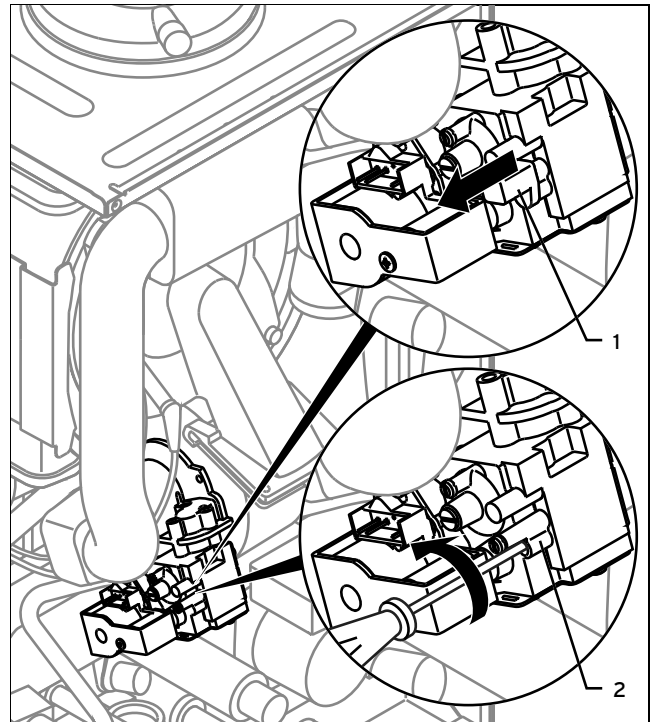

- ▶ Remove the yellow sticker.
- ▶ Remove the covering cap **(1)**.
- ▶ Set the CO₂ content (value with front casing removed) by turning the screw **(2)**.
 - Higher CO₂ content: Turn anti-clockwise
 - Lower CO₂ content: Turn clockwise
- ▶ For natural gas only: Only perform the adjustment in small increments of a 1/8 turn and wait approx. one minute after each adjustment until the value stabilises.
- ▶ For liquid gas only: Only perform the adjustment in extremely small increments (approx. 1/16 turn), and wait approx. one minute after each adjustment until the value stabilises.
- ▶ After you have implemented the settings, press .
- ▶ If an adjustment is not possible in the specified adjustment range, you must not start up the product.
- ▶ If this is the case, inform Customer Service.
- ▶ Refit the covering cap.
- ▶ Install the front casing.

7.12 Checking function and leak-tightness

Before you hand the product over to the operator:

- ▶ Check the gas line, the flue gas installation, the heating installation and the hot water pipes for leaks.
- ▶ Check that the air/flue pipe and condensate drain pipe-work have been installed correctly.
- ▶ Check that the front casing has been installed correctly.

7.12.1 Checking the heating mode

1. Make sure that there is a heat requirement.
2. Call up the **Live Monitor**.
 - ◁ If the product is working correctly, the display shows **S.04**.

7.12.2 Checking the hot water generation

1. Open a hot water valve all the way.
2. Call up the **Live Monitor**.
 - ◁ If the hot water generation is working correctly, **S.14** appears in the display.

7.13 Thoroughly flushing the heating installation ("hot")

1. Operate the appliance until the boiler and the heating system are up to temperature.
2. Check the heating system for leaks.
3. Connect a hose to the drain valve located at the lowest position of the heating system.
4. Shut off the boiler, open the drain valve and all purge valves on the radiators and allow the water to flow out of the heating system and the boiler quickly and fully.
5. Close the drain valve.
6. Fill the heating system again with water as described in Filling the heating installation (→ Page 19) and Purging the heating installation (→ Page 20).
7. Re-fill the system until the system design pressure of 0,1 MPa (1,0 bar) is attained.



Note

The actual reading on the digital pressure gauge should ideally be 0,05 MPa (0,5 bar) plus an additional pressure corresponding to the highest point of the system above the base of the boiler – 10 m head equals an additional 1 bar reading on the pressure gauge. The minimum pressure should not be less than 0,1 MPa (1 bar) in any installation. If the system is to be treated with an inhibitor it should be applied at this stage in accordance with the manufacturer's instructions. Further information can be obtained from Sentinel, Betz Dearborn Ltd., Tel: 0151 420 9595, or Fernox, Alpha– Fry technologies. Tel: 0870 8700362.

8. Install the front casing.

8 Adapting the unit to the heating installation

8.1 Calling up diagnostics codes

You can find the setting options in the diagnostics codes in the installer level.

Overview of diagnostics codes (→ Page 31)

- ▶ Call up the installer level. (→ Page 17)

8.2 Burner anti-cycling time

To prevent frequent switching on and off of the burner and thus prevent energy losses, an electronic restart lockout is activated for a specific period each time the burner is switched off. The burner anti-cycling time is only active for the heating mode. Hot water handling during a burner anti-cycling time does not affect the time function element (default setting: 20 mins).

8.2.1 Setting the burner anti-cycling time

1. Navigate to diagnostics code **D.002** in the installer level and confirm by pressing .
2. Set the burner anti-cycling time and confirm by pressing .

T _{Flow} (target) [°C]	Set maximum burner anti-cycling time [min]						
	1	5	10	15	20	25	30
30	2.0	4.0	8.5	12.5	16.5	20.5	25.0
35	2.0	4.0	7.5	11.0	15.0	18.5	22.0
40	2.0	3.5	6.5	10.0	13.0	16.5	19.5
45	2.0	3.0	6.0	8.5	11.5	14.0	17.0
50	2.0	3.0	5.0	7.5	9.5	12.0	14.0
55	2.0	2.5	4.5	6.0	8.0	10.0	11.5
60	2.0	2.0	3.5	5.0	6.0	7.5	9.0
65	2.0	1.5	2.5	3.5	4.5	5.5	6.5
70	2.0	1.5	2.0	2.5	2.5	3.0	3.5
75	2.0	1.0	1.0	1.0	1.0	1.0	1.0

T _{Flow} (target) [°C]	Set maximum burner anti-cycling time [min]					
	35	40	45	50	55	60
30	29.0	33.0	37.0	41.0	45.0	49.5
35	25.5	29.5	33.0	36.5	40.5	44.0
40	22.5	26.0	29.0	32.0	35.5	38.5
45	19.5	22.5	25.0	27.5	30.5	33.0
50	16.5	18.5	21.0	23.5	25.5	28.0
55	13.5	15.0	17.0	19.0	20.5	22.5
60	10.5	11.5	13.0	14.5	15.5	17.0
65	7.0	8.0	9.0	10.0	11.0	11.5
70	4.0	4.5	5.0	5.5	6.0	6.5
75	1.0	1.0	1.0	1.0	1.0	1.0

8 Adapting the unit to the heating installation

8.2.2 Resetting the remaining burner anti-cycling time

- ▶ Press **X**.

8.3 Setting the maintenance interval

1. Navigate to diagnostics code **D.084** in the installer level and confirm by pressing **OK**.
2. Set the maintenance interval (operating hours) until the next maintenance work is due and confirm by pressing **OK**.

Heat demand	Number of persons	Guideline value for burner operating hours until the next inspection/maintenance work is due for an average operating time of one year (dependent upon the system type)
5.0 kW	1 - 2	1050 h
	2 - 3	1150 h
10.0 kW	1 - 2	1500 h
	2 - 3	1600 h
15.0 kW	2 - 3	1800 h
	3 - 4	1900 h
20.0 kW	3 - 4	2600 h
	4 - 5	2700 h
25.0 kW	3 - 4	2800 h
	4 - 6	2900 h
> 27.0 kW	3 - 4	3000 h
	4 - 6	3000 h

8.4 Setting the pump output

1. Navigate to diagnostics code **D.014** in the installer level and confirm by pressing **OK**.
2. Set the required pump output.

Conditions: Low loss header installed

- ▶ Switch off the speed regulation and set the pump output to a fixed value.

8.4.1 Remaining feed head of the pump

8.4.1.1 Pump characteristic line for VUW 246, VUW 286

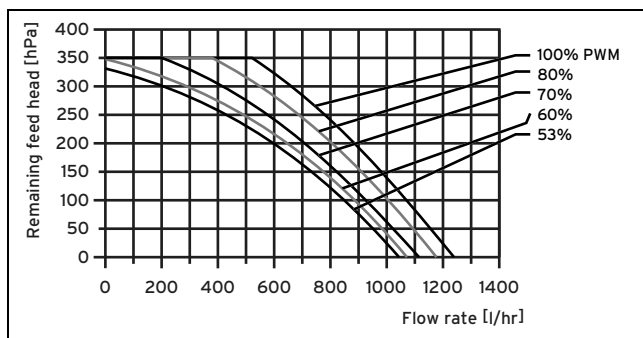

8.4.1.2 Pump characteristic line for VUW 306

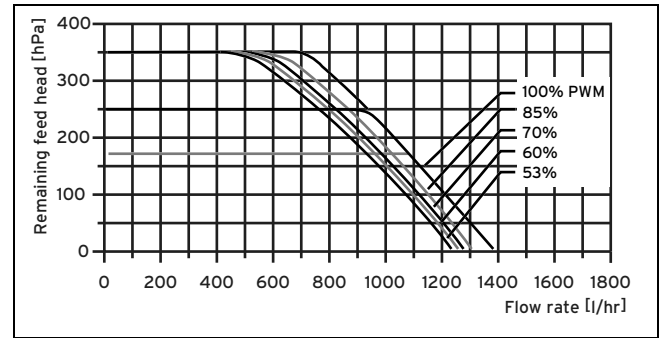

8.5 Setting the bypass valve



Caution.

Risk of material damage caused by incorrect setting of the high-efficiency pump

If the pressure at the bypass valve is increased (by turning it clockwise) and the pump output is set to less than 100%, the product may not operate correctly.

- ▶ In this case, set the pump output to 5 = 100% using diagnostics code D.014.

- ▶ Remove the front casing. (→ Page 11)

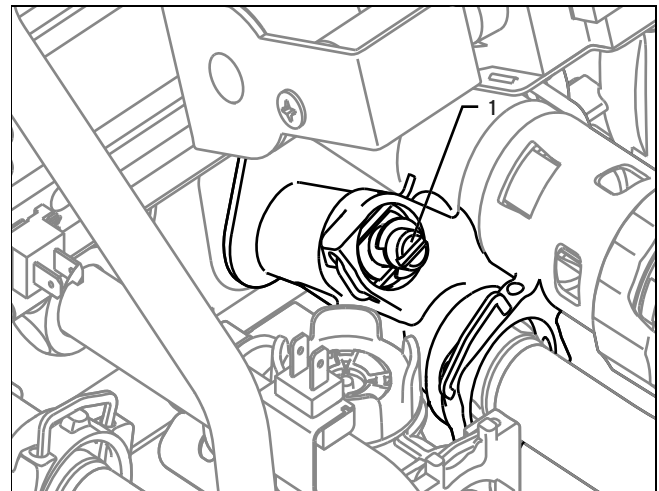

- ▶ Regulate the pressure using the adjusting screw (1).

Position of the adjusting screw	Pressure in MPa (mbar)	Notes/application
Right-hand stop (turned all the way down)	0.035 (350)	If the radiators do not heat up sufficiently at the default setting. In this case, you must set the pump to the maximum speed.
Mid-position (5 turns to the left)	0.025 (250)	Default setting
5 further turns to the left from the mid-position	0.017 (170)	If noises are produced in the radiators or radiator valves

- ▶ Install the front casing.

8.6 Handing the product over to the operator

- ▶ When you have finished the installation, affix the enclosed sticker (which requests that the user reads the instructions) to the front of the product in the operator's language.
- ▶ Explain to the operator how the safety devices work and where they are located.
- ▶ Inform the operator how to handle the product.
- ▶ In particular, draw attention to the safety information which the operator must follow.
- ▶ Inform the operator of the necessity to have the product maintained according to the specified intervals.
- ▶ Pass all of the instructions and documentation for the product to the operator for safe-keeping.
- ▶ Inform the operator about measures taken to ensure the supply of combustion air and flue gas guiding, and instruct the operator that he must not make any changes.
- ▶ Inform the operator that they must not store or use explosive or highly flammable substances (such as petrol, paper or paint) in the installation room of the product.
- ▶ Complete and sign off the Benchmark commissioning check list.
- ▶ Complete and sign off the guarantee documentation.

9 Troubleshooting

9.1 Checking service messages

 appears if you have set a maintenance interval, for example, and this has passed or a service message is issued. The product is not in fault mode.

- ▶ Call up the Live Monitor. (→ Page 17)

Conditions: S.46 is displayed

The product is in Comfort protection mode. The product continues to run with restricted comfort after it has detected a fault.

- ▶ To establish whether or not a component is defective, read the fault memory. (→ Page 25)



Note

If no fault message is present, the product will automatically switch back to normal operating mode after a certain time.

9.2 Rectifying faults



- ▶ If fault messages (**F.xx**) appear, rectify the fault by referring to the table in the appendix or using the function menu for the check programmes. (→ Page 18)
Overview of fault codes (→ Page 35)

If several faults occur at the same time, the display shows the corresponding fault messages for two seconds each in alternation.

- ▶ Press  (max. three times) to restart the product.
- ▶ If you are unable to remedy the fault and the fault recurs despite fault clearance attempts, contact customer service.

9.3 Calling up and clearing the fault memory

The last 10 fault messages are stored in the fault memory.

- ▶ Call up the installer level. (→ Page 17)
- ▶ Navigate to the **fault codes**.
 - ◁ The number of faults that have occurred is shown in the display and the faults that are currently called up are displayed with their fault numbers **F.xx**.
- ▶ Press  or  to call up individual fault messages.
- ▶ To delete the entire fault list, navigate to diagnostics code **D.094** in the installer level.
- ▶ Set the diagnostics code to **1**, and confirm by pressing .

9.4 Resetting parameters to factory settings

1. Navigate to diagnostics code **D.096** in the installer level.
2. Set the diagnostics code to 1, and confirm by pressing .

9.5 Preparing the repair work

1. Decommission the product.
2. Disconnect the product from the power mains.
3. Remove the front casing. (→ Page 11)
4. Close the gas isolator cock.
5. Close the service valves in the heating flow and in the heating return.
6. Close the service valve in the cold water pipe.
7. Drain the product if you want to replace water-bearing components of the product.
8. Make sure that water does not drip on live components (e.g. the electronics box).
9. Use only new seals.

9.5.1 Procuring spare parts

The original components of the product were also certified as part of the declaration of conformity. If you do not use certified Vaillant original spare parts for maintenance or repair work, this voids the conformity of the product. We therefore strongly recommend that you fit Vaillant genuine spare parts. Information about available Vaillant original spare parts is available by contacting the contact address provided on the reverse of this document.

- ▶ If you require spare parts for maintenance or repair work, use only Vaillant genuine spare parts.

9.6 Replacing defective components

9.6.1 Replacing the burner

1. Remove the compact thermal module. (→ Page 28)

9 Troubleshooting

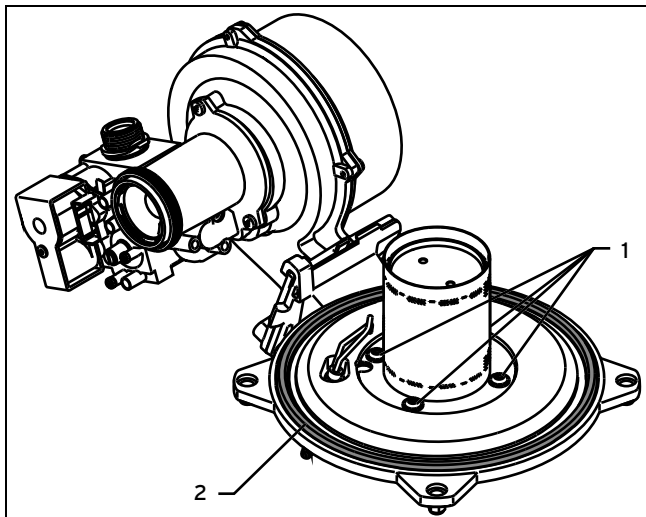

2. Undo the four screws (1) on the burner.
3. Remove the burner.
4. Install a new seal (2) on the new burner.
5. Install the compact thermal module. (→ Page 30)

9.6.2 Replacing the fan or gas valve

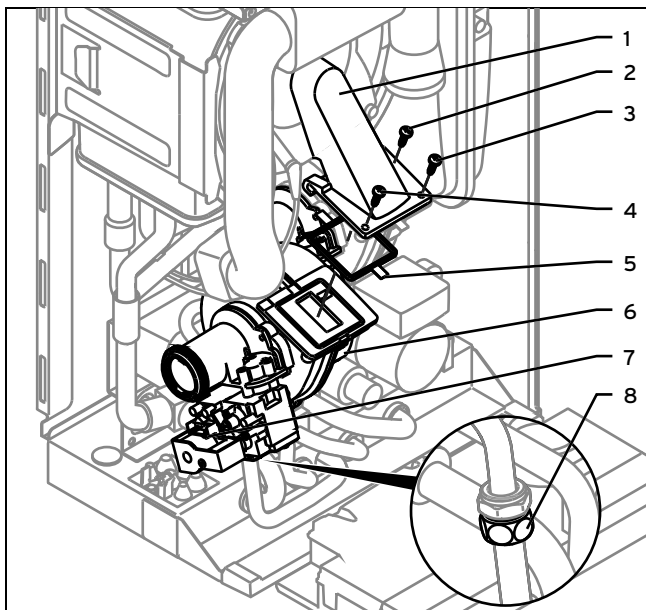

1. Remove the air intake pipe.
2. Remove the plug from the gas valve (7).
3. Remove the plug from the fan motor (6) by pushing in the latching lug.
4. Unscrew either the cap nut (2) on the gas valve or the cap nut (8) between the gas pipes. Secure the gas pipe against twisting.
5. Unscrew the three screws (2)-(4) between the mixture pipe (1) and the fan flange.

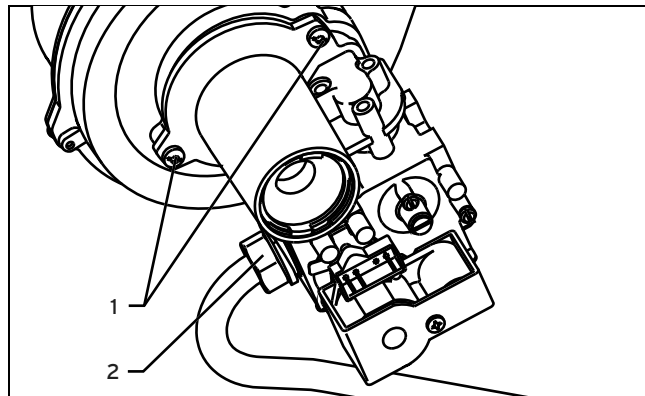

6. Remove the entire fan/gas valve unit from the product.
7. If you want to replace the gas valve, unscrew the cap nut (2) if the gas pipe is still secured to the gas valve.
8. Unscrew both fixing screws (1) on the gas valve and remove the fan from the gas valve.
9. Replace the defective fan or the defective gas valve.
10. Install the gas valve and the fan in the same position as before. Use new seals.
11. Screw the fan to the gas valve.
12. If you had removed the gas pipe, screw the cap nut of the gas pipe (2) only loosely to the gas valve. Only tighten the cap nut on the gas valve after the installation work has been completed.
13. Refit the entire fan/gas valve unit in reverse order. You must use a new seal (5) for this.
14. Ensure that the order in which the three screws are screwed in between the fan and the mixture pipe corresponds to the numbering (3), (2) and (4).
15. Tighten the cap nut (2) on the gas valve and the cap nut (8) between the gas pipes. In the process, secure the gas pipe against twisting. Use new seals.
16. After you have completed this work, carry out a leak-tightness test (function check). (→ Page 23)
17. If you have installed a new gas valve, adjust the gas ratio setting. (→ Page 20)

9.6.3 Replacing the heat exchanger

1. Drain the product. (→ Page 30)
2. Remove the compact thermal module. (→ Page 28)
3. Detach the condensate drain hose from the heat exchanger.

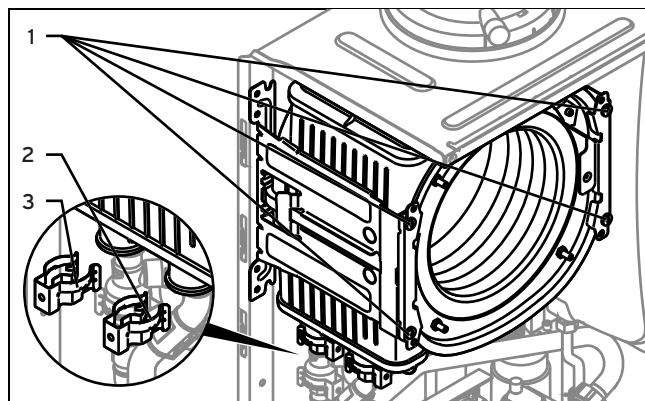

4. Remove the clamps (2) and (3) from the flow connection and the return connection.
5. Detach the flow connection.

6. Detach the return connection.
7. Remove two screws (1) on each of the two retainers.

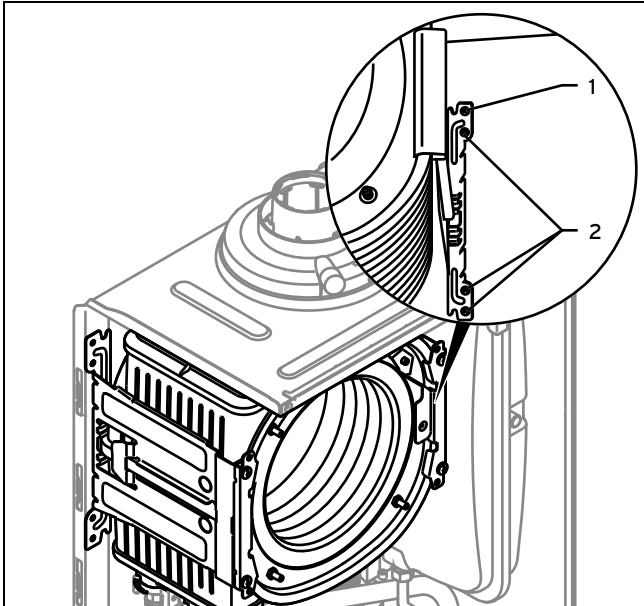

8. Remove the lower three screws (2) on the rear section of the retainer.
9. Swing the retainer to the side around the top screw (1).
10. Pull the heat exchanger downwards and to the right, and remove it from the product.
11. Install the new heat exchanger in reverse order.
12. Replace the seals.



Note

Instead of grease, use only water or commercially available soft soap to aid installation.

13. Insert the flow and return connections into the heat exchanger as far as they will go.
14. Make sure that the brackets are seated correctly on the flow and return connections.
15. Install the compact thermal module. (→ Page 30)
16. Fill and purge the product and, if necessary, the heating installation. (→ Page 19)

9.6.4 Replacing the expansion vessel

1. Drain the product. (→ Page 30)

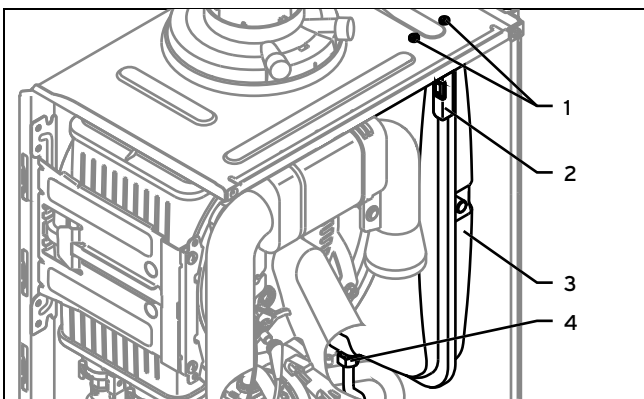

2. Undo the screwed connection (4).

3. Remove both screws (1) on the support plate (2).
4. Remove the support plate (2).
5. Pull out the expansion vessel (3) towards the front.
6. Insert the new expansion vessel into the product.
7. Screw the new expansion vessel to the water connection. Use a new seal for this.
8. Attach the support plate using both screws (1).
9. Fill and purge the product and, if necessary, the heating installation. (→ Page 19)

9.6.5 Replacing the PCB or the display

Note

If you only replace one component, when the product is switched on, the new component adopts the parameters that were previously set from the component that was not replaced.

1. Open the electronics box. (→ Page 15)
2. Replace the PCB or display according to the assembly and installation instructions supplied.
3. Close the electronics box.

9.6.6 Replacing the PCB and the display

1. Open the electronics box. (→ Page 15)
2. Replace the PCB and display according to the assembly and installation instructions supplied.
3. Close the electronics box.
4. Press the on/off button on the product. (→ Page 18)
 - ◁ You are automatically taken to **D.093** to set the device specific number.
5. Set the correct value for the relevant product type in accordance with the table below and confirm by pressing .

Product type number

24 (VUW GB 246/5-3 A) ecoTEC pro	7
28 (VUW GB 286/5-3 A) ecoTEC pro	22
30 (VUW GB 306/5-3) ecoTEC pro	26

- ◁ The electronics are now set to the product type and the parameters of all diagnostics codes are set to default settings.
6. Make the system-specific settings.

9.7 Completing repair work

1. Establish the power supply.
2. Switch the product back on if this has not yet been done. (→ Page 18)
3. Install the front casing.
4. Open all service valves and the gas isolator cock.
5. Check that it works correctly and is leak-tight. (→ Page 23)

10 Inspection and maintenance

10 Inspection and maintenance

- ▶ You must carry out an annual inspection of the product. The annual inspection can be effectively performed without removing components by requesting data from the DIA system, carrying out the simple visual checks indicated in the table in the appendix and performing a flue gas measurement. The maintenance intervals and their scope are determined by the heating engineer based on the condition of the boiler found during the inspection. All inspection and maintenance work should be performed in the order specified in the table in the appendix.
Inspection and maintenance work – Overview
(→ Page 39)

During any inspection and maintenance or after change of parts of the combustion circuit, the following must be checked:

- The boiler has been installed in accordance with the relevant installation instructions.
 - The integrity of the flue gas installation and flue seals is in accordance with the relevant flue installation instructions enclosed.
 - Visual, the integrity of the boiler combustion circuit and relevant seals (paying particular attention to the burner door seal).
 - The gas inlet working pressure at maximum rate.
 - The gas flow rates.
 - Correctness of electrical, water and gas connections.
 - Correctness of the water pressure.
 - The condition of the whole system, in particular the condition of radiator valves, evidence of leakage from the heating system and dripping taps.
- ▶ Correct any faults before proceeding.

10.1 Removing the compact thermal module



Note

The compact thermal module consists of four main components:

- Speed-regulated fan,
- Gas/air connection,
- Gas supply (mixture pipe) with burner flange,
- Premix burner.



Danger!

Risk of death and risk of material damage caused by hot flue gas.

The seal, insulating mat and self-locking nuts on the burner flange must not be damaged. Otherwise, hot flue gases may escape and cause personal injury and material damage.

- ▶ Replace the seal each time you open the burner flange.
- ▶ Replace the self-locking nuts on the burner flange each time you open the burner flange.
- ▶ If the insulating mat on the burner flange or on the back wall of the heat exchanger

shows signs of damage, replace the insulating mat.

1. Switch off the product using the on/off button.
2. Close the gas isolator cock.
3. Remove the front casing.
4. Tilt the electronics box forward.

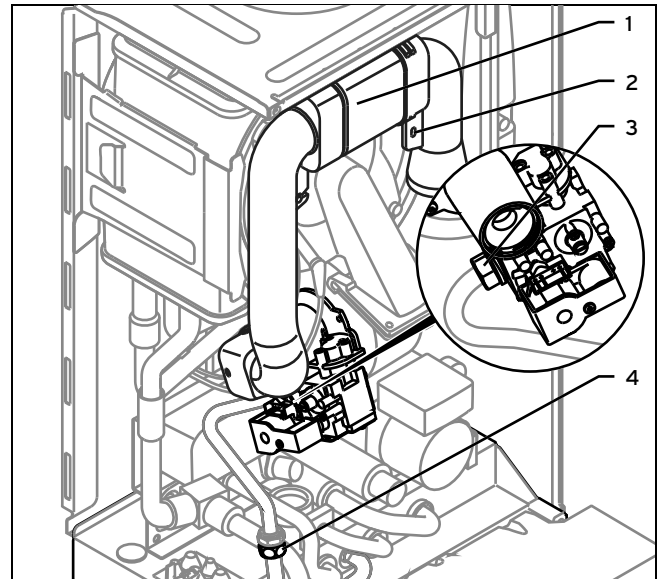

5. Unscrew the retaining screw (2) and remove the air intake pipe (1) from the intake stub.
6. Unscrew either the cap nut on the gas valve (3) or the cap nut (4) between the gas pipes.

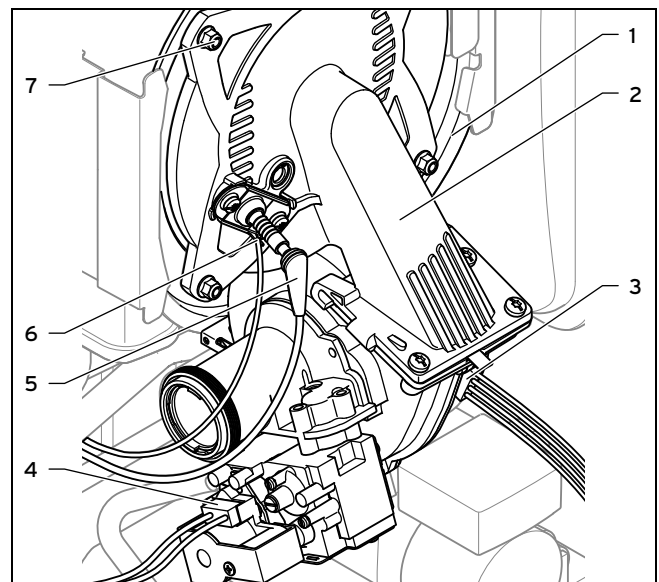

7. Remove the ignition line plug (5) and the earth line plug (6) from the ignition electrode.
8. Remove the plug (3) from the fan motor.
9. Remove the plug (4) from the gas valve.
10. Unscrew the four nuts (7).
11. Remove the entire compact thermal module (2) from the heat exchanger (1).
12. Check the burner and the heat exchanger for damage and dirt.
13. If necessary, clean or replace the components according to the following sections.

14. Fit a new burner flange seal.
15. Check the insulating mat on the burner flange and on the back wall of the heat exchanger. If you notice any signs of damage, replace the relevant insulating mat.

10.2 Cleaning the heat exchanger

1. Protect the folded down electronics box against sprayed water.

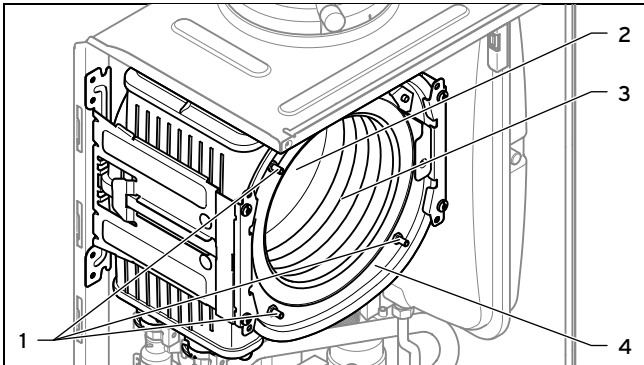

2. Never undo the four nuts on the stud bolt (1) or tighten them.
3. Clean the heating coil (3) of the heat exchanger (4) using water or, if required, vinegar (to a maximum of 5% acid). Allow the vinegar to act on the heat exchanger for 20 minutes.
4. Rinse away any loose dirt with a sharp jet of water or use a plastic brush. Do not point the water jet directly at the insulating mat (2) on the back of the heat exchanger.
 - ◁ The water flows out of the heat exchanger through the condensate siphon.

10.3 Checking the burner

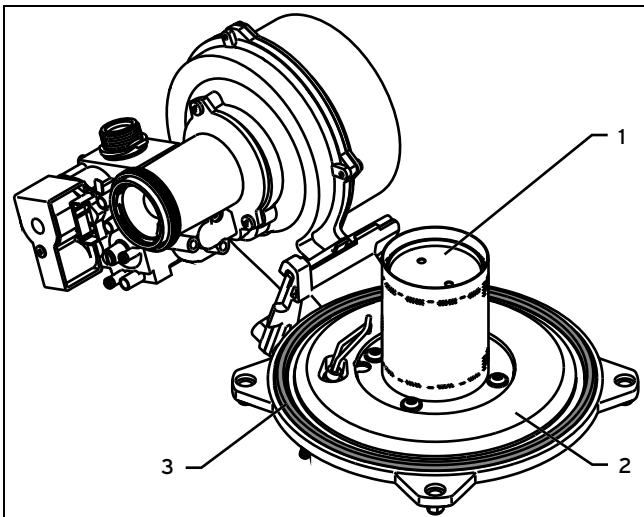

1. Check the surface of the burner (1) for damage. If you see any damage, replace the burner.
2. Fit a new burner flange seal (3).
3. Check the insulating mat (2) on the burner flange. If you notice any signs of damage, replace the insulating mat.

10.4 Cleaning the condensate trap

1. Remove the lower section of the condensate trap (1).
2. Flush out the lower section with water.
3. Fill the lower section with water up to about 10 mm below the upper edge.
4. Attach the lower section to the condensate trap.

10.5 Cleaning the filter in the cold water inlet

Applicability: Product with integrated hot water generation

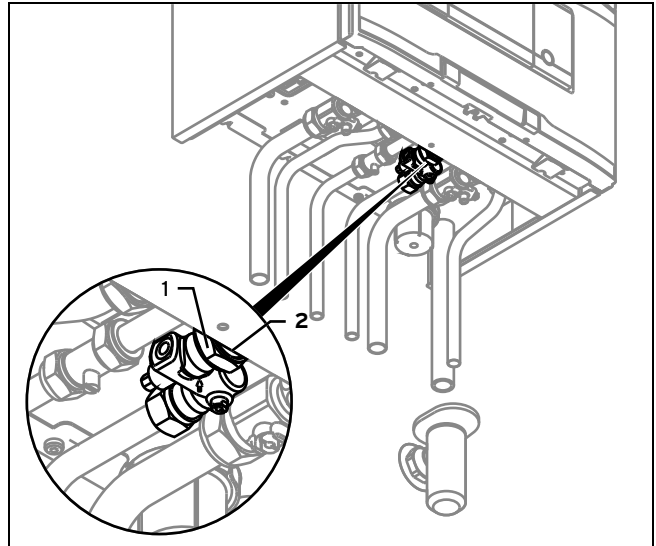

1. Close the cold water stop valve.
2. Drain the product on the hot water side.
3. Unscrew the cap nut (2) and the lock nut (1) from the product's casing.

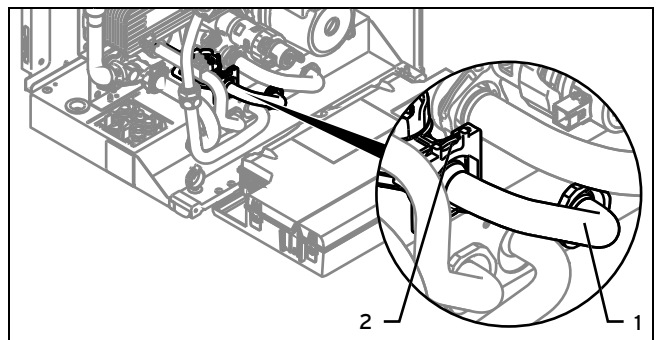

4. Tilt the electronics box forward.
5. Remove the clamp (2).
6. Remove the pipe (1) from the product.
7. Rinse the filter under a jet of water, holding it against the direction of flow.
8. If the filter is damaged or it can no longer be cleaned sufficiently, you must replace the filter.
9. Refit the pipe.
10. Reinsert the clamp.
11. Always use new seals and retighten the cap nuts and the lock nut.
12. Open the cold water stop valve.

11 Decommissioning

10.6 Installing the compact thermal module

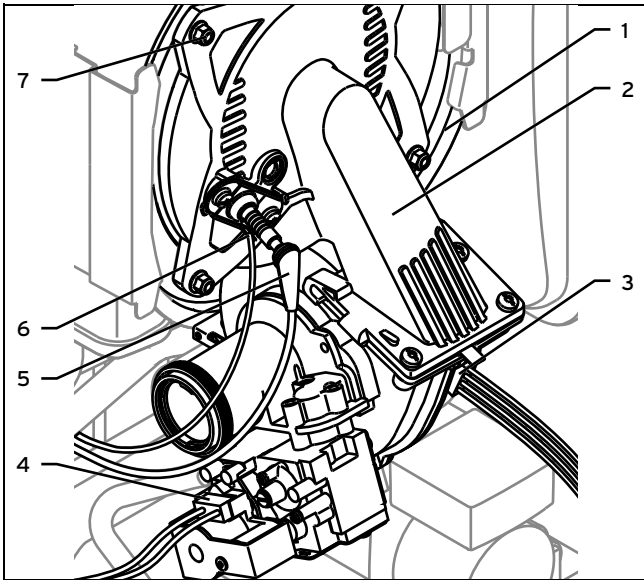

1. Connect the compact thermal module (2) to the heat exchanger (1).
2. Tighten the four nuts (7) in a cross-wise pattern until the burner flange fits closely and uniformly onto the mating surfaces (if a torque spanner is available, set at 6 Nm).
3. Connect the plugs (3) to (6) again.
4. Connect the gas line using a new seal. In the process, secure the gas pipe against twisting.
5. Open the gas isolator cock.
6. Make sure that there are no leaks.
7. Check that the sealing ring in the air intake pipe is positioned correctly in the seal seat.
8. Reconnect the air intake pipe to the intake nozzle.
9. Secure the air intake pipe with the retaining screw.
10. Check the gas flow pressure.

10.7 Draining the product

1. Close the service valves of the product.
2. Start the check programme **P.06** (diverter valve mid-position).
3. Open the drain valves.
4. Make sure that the cap of the automatic air vent on the internal pump is open so that the product can be drained fully.

10.8 Checking the pre-charge pressure for the internal expansion vessel

1. Close the service valves and drain the product.
2. Measure the pre-charge pressure of the expansion vessel at the vessel valve.

Conditions: Pre-charge pressure < 0.075 MPa (0.75 bar)

- ▶ Ideally, you should top up the expansion vessel with nitrogen. Otherwise, top it up with air. Ensure that the drain valve is open when topping up.
3. If water escapes from the valve of the expansion vessel, you must replace the expansion vessel. (→ Page 27)
 4. Fill the heating installation. (→ Page 19)
 5. Purge the heating installation. (→ Page 20)

10.9 Completing inspection and maintenance work

Once you have completed all maintenance work:

- ▶ Check the gas flow pressure. (→ Page 21)
- ▶ Check the CO₂ content and, if necessary, adjust it (air index setting). (→ Page 22)
- ▶ If required, reset the maintenance interval. (→ Page 24)

11 Decommissioning

11.1 Temporarily decommissioning the product

- ▶ Press the on/off button.
 - ◀ The display goes out.
- ▶ Close the gas isolator cock.
- ▶ On combination products and products with a connected domestic hot water cylinder, you must also close the cold water stop valve.

11.2 Decommissioning the product

- ▶ Press the on/off button.
 - ◀ The display goes out.
- ▶ Disconnect the product from the power mains.
- ▶ Close the gas isolator cock.
- ▶ Close the cold water stop valve.
- ▶ Drain the product. (→ Page 30)

12 Recycling and disposal

Disposing of the packaging

- ▶ Dispose of the packaging correctly.
- ▶ Observe all relevant regulations.

13 Customer service

To ensure regular servicing, it is strongly recommended that arrangements are made for a Maintenance Agreement. Please contact Vaillant Service Solutions for further details.

Vaillant Service Solutions: 0330 100 3461

Appendix

A Overview of diagnostics codes

Code	Parameter	Values or explanations	Default setting	Own setting
D.000	Heating partial load	Adjustable heating partial load in kW Auto: Product automatically adjusts max. partial load to current system demand	Auto	
D.001	Overrun time of internal heating pump for heating mode	1 ... 60 min	5 min	
D.002	Max. burner anti-cycling time heating at 20 °C flow temperature	2 ... 60 min	20 min	
D.003	Outlet temp. actual value	In °C		Not adjustable
D.004	Measured value of hot water sensor			Not adjustable
D.005	Flow temperature target value (or return target value)	In °C, max. of the value set in D.071, limited by an eBUS controller if connected		Not adjustable
D.006	Hot water temperature target value (only products with integrated hot water generation)	35 ... 65 °C		Not adjustable
D.007	Warm start temperature target value (only products with integrated hot water generation) Cylinder temperature target value (only products with heating mode only)	35 ... 65 °C - Frost protection is at 15 °C, then 40 to 70 °C (max. temperature can be adjusted under D.020)		Not adjustable
D.008	Room thermostat at terminal RT	Room thermostat open (no heat requirement) Room thermostat closed (heat requirement)		Not adjustable
D.009	Target value from external eBUS controller	In °C		Not adjustable
D.010	Status of internal heating pump	1= On, 0 = Off		Not adjustable
D.011	Status of external heating pump	1-100 = On, 0 = Off		Not adjustable
D.012	Status of cylinder charge pump	1 = on, 0 = off		Not adjustable
D.013	Status of hot water circulation pump	1 = on, 0 = off		Not adjustable
D.014	Target pump speed (high-efficiency pump)	Target value of internal high-efficiency pump in %. Possible settings: 0 = Auto 1 = 53 2 = 60 3 = 70 4 = 85 5 = 100	0 = Auto	
D.015	Actual pump speed (high-efficiency pump)	Actual value for internal high-efficiency pump in %		Not adjustable
D.016	24 V DC room thermostat open/closed	0 = Room thermostat open/heating mode off 1 = Room thermostat closed/heating mode on		Not adjustable
D.017	Heating flow/return flow temperature control changeover	Control type: 0 = Flow, 1 = Return Return: Automatic detection function for heating output inactive. Max. possible heating partial load when D.000 is on Auto .	0 = Flow	

Appendix

Code	Parameter	Values or explanations	Default setting	Own setting
D.018	Pump operating mode setting	1 = Comfort (continuously operating pump) Internal pump is switched on when the heating flow temperature is not at Heating off and the heat requirement is enabled via an external controller 3 = Eco (intermittently operating pump) Internal pump is switched on every 25 minutes for 5 minutes once the overrun time has elapsed	3 = Eco	
D.019	Operating mode of 2-stage pump	Not relevant		Not adjustable
D.020	Max. setting for cylinder target value	Adjustment range: 50 - 70 °C (actoSTOR 65 °C)	65 °C	
D.022	Hot water requirement (via C1/C2, impeller or APC)	0 = On, 1 = Off		Not adjustable
D.023	Summer/winter mode (heating off/on)	1 = Heating on, 0 = Heating off (summer mode)		Not adjustable
D.025	Hot water generation enabled by eBUS controller	1 = on, 0 = off		Not adjustable
D.026	Auxiliary relay control	Not relevant		
D.027	Switching of relay 1 on the VR 40 "2 in 7" multi-functional module	1 = Circulation pump 2 = External pump 3 = Cylinder charging pump 4 = Extractor hood 5 = External solenoid valve 6 = External fault message 7 = Solar pump (not active) 8 = eBUS remote control (not active) 9 = Legionella protection pump (not active) 10 = Solar valve (not active)	2 = External pump	
D.028	Switching of relay 2 on the VR 40 "2 in 7" multi-functional module	1 = Circulation pump 2 = External pump 3 = Cylinder charging pump 4 = Extractor hood 5 = External solenoid valve 6 = External fault message 7 = Solar pump (not active) 8 = eBUS remote control (not active) 9 = Legionella protection pump (not active) 10 = Solar valve (not active)	2 = External pump	
D.033	Fan speed target value	In rpm		Not adjustable
D.034	Fan speed actual value	In rpm		Not adjustable
D.035	Position of the diverter valve	0 = Heating mode 40 = Parallel operation (mid-position) 100 = Hot water handling mode		Not adjustable
D.036	Hot water flow volume (impeller sensor)	In l/min		Not adjustable
D.039	Solar feed temperature	Actual value in °C		Not adjustable
D.040	Flow temperature	Actual value in °C		Not adjustable
D.041	Return temperature	Actual value in °C		Not adjustable
D.044	Digitised ionisation value	Display field 0 to 1020 > 800 no flame < 400 good flame		Not adjustable
D.046	Pump type	0 = Relay with disable facility 1 = PWM with disable facility	0 = Relay with disable facility	

Code	Parameter	Values or explanations	Default setting	Own setting
D.047	Outside temperature (with Vaillant weather compensator)	Actual value in °C		Not adjustable
D.050	Offset for minimum speed	In rpm, setting range: 0 to 3000	Nominal value set in factory	
D.051	Offset for maximum speed	In rpm, setting range: -990 to 0	Nominal value set in factory	
D.058	Activating solar post-heating (only products with integrated hot water generation)	0 = Solar post-heating deactivated 3 = DHW activation target value minimum 60 °C, thermostatic mixer valve required between product and draw-off point	0 = Solar post-heating deactivated	
D.060	Number of temperature limiter shut-downs	Number of shutdowns		Not adjustable
D.061	Number of ignition device cutoffs	Number of unsuccessful ignitions in the last attempt		Not adjustable
D.064	Average ignition time	In seconds		Not adjustable
D.065	Maximum ignition time	In seconds		Not adjustable
D.067	Remaining burner anti-cycling time	In minutes		Not adjustable
D.068	Unsuccessful ignitions at 1st attempt	Number of unsuccessful ignitions		Not adjustable
D.069	Unsuccessful ignitions at 2nd attempt	Number of unsuccessful ignitions		Not adjustable
D.070	Set diverter valve position	0 = Normal operating mode 1 = Parallel operation (mid-position) 2 = Permanent heating mode position	0 = Normal operating mode	
D.071	Target value maximum heating flow temperature	40 ... 80 °C	75 °C	
D.072	Internal pump overrun after cylinder charging	Adjustable from 0-10 minutes in increments of 1 minute	2 mins	
D.073	Warm start target offset	Adjustable from -15 K to 5 K	0	
D.074	actoSTOR anti-legionella function	0 = Off 1 = On	1 = On	
D.075	Max. charging time for domestic hot water cylinder without independent control system	20 - 90 min	45 mins	
D.076	Device Specific Number Device specific number = DSN)	7 = 24 (VUW GB 246/5-3A) 22 = 28 (VUW GB 286/5-3A) 26 = 30 (VUW GB 306/5-3)		Not adjustable
D.077	Limit on cylinder charging output in kW	Adjustable cylinder charging output in kW		
D.078	Limit on cylinder charging temperature in °C	50 °C - 80 °C Note The chosen value must be at least 15 K or 15 °C above the set cylinder target value.		75 °C
D.080	Operating hours, heating	In hours (h)		Not adjustable
D.081	Operating hours, hot water generation	In hours (h)		Not adjustable
D.082	Number of burner start-ups in heating mode	Number of burner start-ups		Not adjustable
D.083	Number of burner start-ups in hot water mode	Number of burner start-ups		Not adjustable
D.084	Maintenance indicator: Number of hours until the next maintenance	Adjustment range: 0 to 3000 hrs and "----" for deactivated	"----"	

Code	Parameter	Values or explanations	Default setting	Own setting
D.088	Start delay for hot water draw-off detection via impeller (only products with integrated hot water generation)	0 = 1.5 l/min and no delay, 1 = 3.7 l/min and 2 sec. delay	1.5 l/min and no delay	
D.090	Status of digital controller	1 = recognised, 0 = not recognised		Not adjustable
D.091	Status of DCF with external temperature sensor connected	0 = No reception 1 = Reception 2 = Synchronised 3 = Valid		Not adjustable
D.092	actoSTOR module recognition	Not relevant		Not adjustable
D.093	Setting the Device Specific Number (DSN)	Setting range: 0 to 99		
D.094	Delete fault history	Delete fault list 0 = No 1 = Yes		
D.095	Software version of PeBUS components	PCB (BMU) Display (AI) HBI/VR34		Not adjustable
D.096	Default setting	Reset all adjustable parameters to factory setting 0 = No 1 = Yes		

B Status codes – Overview

Status code	Meaning
Heating mode	
S.00	Heating: No heat demand
S.01	Heating mode: Fan start-up
S.02	Heating mode: Pump pre-run
S.03	Heating mode: Ignition
S.04	Heating mode: Burner on
S.05	Heating mode: Pump/fan overrun
S.06	Heating mode: Fan overrun
S.07	Heating mode: Pump overrun
S.08	Heating mode: Remaining anti-cycling time
DHW mode	
S.10	Hot water requirement via flow sensor
S.11	DHW mode: Fan start-up
S.13	DHW mode: Ignition
S.14	DHW mode: Burner on
S.15	DHW mode: Pump/fan overrun
S.16	DHW mode: Fan overrun
S.17	DHW mode: Pump overrun
Comfort mode, warm start or hot water handling mode with cylinder	
S.20	DHW demand
S.21	DHW mode: Fan start-up
S.22	DHW mode: Pump pre-run
S.23	DHW mode: Ignition
S.24	DHW mode: Burner on
S.25	DHW mode: Pump/fan overrun

Status code	Meaning
S.26	DHW mode: Fan overrun
S.27	DHW mode: Pump overrun
S.28	Hot water burner anti-cycling time
Others	
S.30	Room thermostat (RT) is blocking heating mode
S.31	Summer mode active or no heat requirement from eBUS controller
S.32	Waiting period because of fan speed deviation
S.34	Frost protection mode active
S.37	Waiting time: Fan failure in operation
S.39	"Burner off contact" has responded (e.g. contact thermostat or condensate pump)
S.41	Water pressure > 2.8 bar
S.42	Flue non-return flap return signal blocks burner operation (only in connection with VR 40 accessories) or condensate pump faulty, heat requirement is blocked
S.46	Comfort protection mode, flame loss at minimum load
S.53	Product is within the waiting period of the modulation block/operation block function as a result of low water pressure (flow/return spread too large)
S.54	Product is within the waiting period of the operation blocking function as a result of low water pressure (temperature gradient)
S.57	Waiting period, comfort safety mode
S.58	Modulation limitation due to noise/wind
S.76	System pressure too low. Top up water.
S.96	Return sensor test running, heating demands are blocked.
S.97	Water pressure sensor test running, heating demands are blocked.
S.98	Flow/return sensor test running, heating demands are blocked.

C Overview of fault codes

Code	Meaning	Cause
F.00	Flow temperature sensor interruption	NTC plug not plugged in or has come loose, multiple plug on the PCB not plugged in correctly, interruption in cable harness, NTC defective
F.01	Return temperature sensor interruption	NTC plug not plugged in or has come loose, multiple plug on the PCB not plugged in correctly, interruption in cable harness, NTC defective
F.10	Flow NTC short circuit	NTC defective, short circuit in cable harness, cable/casing
F.11	Return NTC short circuit	NTC defective, short circuit in cable harness, cable/casing
F.20	Safety switch-off: Temperature limiter	Incorrect earth connection between cable harness and product, flow or return NTC defective (loose connection), black discharge via ignition cable, ignition plug or ignition electrode
F.22	Safety switch-off: Low water pressure	No or insufficient water in the product, water pressure sensor defective, cable to pump or water pressure sensor loose/not connected/defective
F.23	Safety switch-off: Temperature difference too great	Pump blocked, insufficient pump output, air in product, flow and return NTC connected the wrong way round
F.24	Safety switch-off: Temperature rise too fast	Pump blocked, insufficient pump output, air in product, system pressure too low, non-return valve blocked/incorrectly installed

Code	Meaning	Cause
F.25	Safety switch-off: Flue gas temperature too high	Break in plug connection for optional flue gas safety temperature limiter (STB), break in cable harness
F.26	Fault: Gas valve without function	Gas valve stepper motor not connected, multiple plug on the PCB not plugged in correctly, interruption in cable harness, gas valve stepper motor defective, electronics defective
F.27	Safety switch-off: Flame simulation	Moisture on the electronics, electronics (flame monitor) defective, gas solenoid valve leaking
F.28	Failure during start-up: Ignition unsuccessful	Gas meter defective or gas pressure monitor has triggered, air in gas, gas flow pressure too low, thermal isolator device (TAE) has triggered, condensate duct blocked, incorrect gas restrictor, incorrect spare part gas valve, fault on the gas valve, multiple plug on PCB incorrectly plugged in, break in cable harness, ignition system (ignition transformer, ignition cable, ignition plug, ignition electrode) defective, ionisation current interrupted (cable, electrode), incorrect earthing of product, electronics defective
F.29	Failure during operation: Re-ignition unsuccessful	Gas supply temporarily stopped, flue gas recirculation, condensate duct blocked, defective earthing of product, ignition transformer has spark failure
F.32	Fan fault	Plug on fan not correctly plugged in, multiple plug on PCB not correctly plugged in, break in cable harness, fan blocked, Hall sensor defective, electronics defective
F.49	Fault: eBUS	Short circuit on eBUS, eBUS overload or two power supplies with different polarities on the eBUS
F.61	Gas valve actuation fault	The gas valve cannot be actuated <ul style="list-style-type: none"> – Cable harness supply line to the gas valve is defective (short to earth, short circuit) – Gas valve defective – PCB defective
F.62	Gas valve switch-off delay	Delayed shutdown of gas valve detected <ul style="list-style-type: none"> – Secondary light (ignition and monitoring electrode indicates delayed extinguishing of the flame signal) – Gas valve defective – PCB defective
F.63	Fault: EEPROM	Electronics defective
F.64	Fault: Electronics/NTC	Flow or return NTC short circuited, electronics defective
F.65	Fault: Electronics temp.	Electronics overheating due to external influences, electronics defective
F.67	Fault: Electronics/flame	Implausible flame signal, electronics defective
F.68	Fault: Unstable flame signal	Air in gas, gas flow pressure too low, incorrect air ratio, condensate duct blocked, incorrect gas restrictor, ionisation flow interruption (cable, electrode), flue gas recirculation, condensate duct
F.70	Invalid device specific number (DSN)	If spare parts fitted: Display and PCB replaced at same time and DSN not reset, incorrect or missing output range coding resistance
F.71	Flow NTC fault	Flow temperature sensor signalling constant value: <ul style="list-style-type: none"> – Flow temperature sensor incorrectly positioned at supply pipe – Flow temperature sensor defective
F.72	Flow/return NTC fault	Flow/return NTC temperature difference too great → flow and/or return temperature sensor defective
F.73	Water pressure sensor signal in the wrong range (too low)	Interruption/short circuit of water pressure sensor, interruption/short circuit to GND in supply line to water pressure sensor or water pressure sensor defective
F.74	Water pressure sensor signal outside correct range (too high)	Line to water pressure sensor has a short circuit to 5 V/24 V or internal fault in the water pressure sensor
F.75	Fault: No pressure change detection when starting pump	Water pressure sensor and/or pump defective, air in the heating installation, insufficient water in the product; check adjustable bypass, connect external expansion vessel to the return
F.77	Fault: Flue non-return flap/condensate pump	No response from flue non-return flap or condensate pump defective

Code	Meaning	Cause
F.78	Interruption to DHW outlet sensor at the external controller	UK link box is connected, but hot water NTC not bridged
F.83	Fault: Flow and/or return temperature sensor temperature change	When the burner starts, the temperature change registered at the flow and/or return temperature sensor is non-existent or too small. <ul style="list-style-type: none"> – Insufficient water in product – Flow or return temperature sensor not in correct position at pipe
F.84	Fault: Flow/return temperature sensor temperature difference implausible	Flow and return temperature sensors returning implausible values. <ul style="list-style-type: none"> – Flow and return temperature sensors have been inverted – Flow and return temperature sensors have not been correctly installed
F.85	Fault: Flow and return temperature sensors incorrectly installed	The flow and/or return temperature sensors have been installed on the same pipe/incorrect pipe
Communication fault	No communication with the PCB	Communication fault between display and PCB in the electronics box

D Connection diagrams

D.1 Product connection diagram with integrated hot water generation

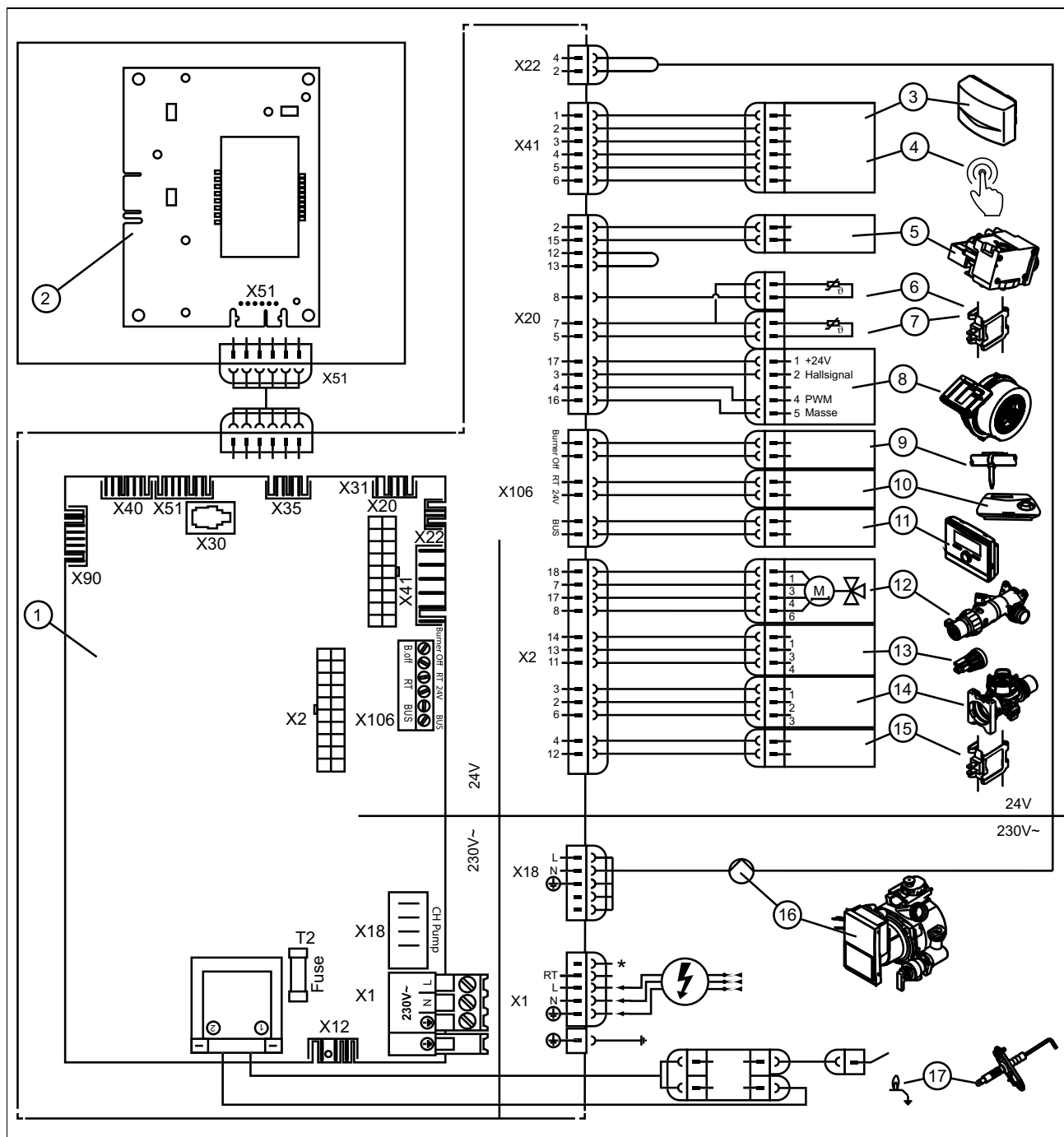

- | | | | |
|----|--|----|---|
| 1 | Main PCB | 10 | 24 V DC room thermostat |
| 2 | Operator control panel PCB | 11 | Bus connection (digital room thermostat/controller) |
| 3 | Outside temperature sensor, flow temperature sensor (optional, external), DCF receiver | 12 | Diverter valve |
| 4 | Circulation pump remote control | 13 | Water pressure sensor |
| 5 | Gas valve | 14 | Impeller sensor |
| 6 | Return temperature sensor | 15 | Warm start sensor |
| 7 | Flow temperature sensor | 16 | Internal pump |
| 8 | Fan | 17 | Ignition electrode |
| 09 | Contact thermostat/burner off | * | Depending on product type |

E Inspection and maintenance work – Overview

The table below lists the manufacturer requirements with respect to minimum inspection and maintenance intervals. If national regulations and directives require shorter inspection and maintenance intervals, you should observe these instead of the intervals listed in the table.

No.	Work	Inspection (annual)	Maintenance (must be carried out at regular intervals)
1	Check the air/flue pipe for leak-tightness and to ensure that it is fastened correctly. Make sure that it is not blocked or damaged and has been installed in accordance with the relevant Installation Manual.	X	X
2	Check the general condition of the product. Remove dirt from the product and from the vacuum chamber.	X	X
3	Visually inspect the general condition of the Thermoblock. In doing so, pay particular attention to signs of corrosion, rust and other defects. If you notice any damage, carry out maintenance work.	X	X
4	Check the gas flow pressure at maximum heat input. If the gas flow pressure is not within the correct range, carry out maintenance work.	X	X
5	Check the CO ₂ content (the air ratio) of the product and, if necessary, adjust it. Keep a record of this.	X	X
6	Disconnect the product from the power mains. Check that the electrical plug connections and other connections are seated correctly and correct these if necessary.	X	X
7	Close the gas isolator cock and the service valves.		X
8	Drain the product on the water side (observe the pressure gauge). Check the pre-charge pressure of the expansion vessel, and top up the vessel if necessary (approx. 0.03 MPa/0.3 bar under the system filling pressure).		X
9	Remove the compact thermal module.		X
10	Check the insulating mats in the combustion area. If you notice any damage, replace the insulating mats. Replace the burner flange seal each time it is opened and accordingly each time maintenance work is carried out.		X
11	Clean the heat exchanger.		X
12	Check the burner for damage and replace it if necessary.		X
13	Check the condensate trap in the product, clean and fill this, if required.	X	X
14	Install the compact thermal module. Caution: Replace the seals.		X
15	If the volume of water is insufficient or the outlet temperature is not reached, replace the secondary heat exchanger if necessary.		X
16	Clean the filter in the cold water inlet. Replace the filter if impurities can no longer be removed or if the filter is damaged. In this case, also check the impeller sensor for dirt and damage, clean the sensor (do not use compressed air for this) and replace the sensor if it is damaged.		X
17	Open the gas isolator cock, reconnect the product to the power mains and switch the product on.	X	X
18	Open the service valves, fill up the product/heating installation to 0.1-0.2 MPa/1.0-2.0 bar (depending on the static height of the heating installation) and start the purging programme P.00 .		X
19	Perform a test operation of the product and heating installation, including hot water generation, and purge the system once more if necessary.	X	X
20	Visually inspect the ignition and burner behaviour.	X	X
21	Check the CO ₂ content (the air ratio) of the product again.		X
22	Check the product for gas, flue gas, hot water and condensate leaks, and repair if necessary.	X	X
23	Record the inspection/maintenance work carried out.	X	X

F Commissioning Checklist

Benchmark Commissioning and Servicing Section

It is a requirement that the boiler is installed and commissioned to the manufacturers instructions and the data fields on the commissioning checklist completed in full.

To instigate the boiler guarantee the boiler needs to be registered with the manufacturer within one month of the installation.

To maintain the boiler guarantee it is essential that the boiler is serviced annually by a Gas Safe registered engineer who has been trained on the boiler installed. The service details should be recorded on the Benchmark Service Interval Record and left with the householder.



www.centralheating.co.uk

GAS BOILER SYSTEM COMMISSIONING CHECKLIST

This Commissioning Checklist is to be completed in full by the competent person who commissioned the boiler as a means of demonstrating compliance with the appropriate Building Regulations and then handed to the customer to keep for future reference.

Failure to install and commission according to the manufacturer's instructions and complete this Benchmark Commissioning Checklist will invalidate the warranty. This does not affect the customer's statutory rights.

Customer name:				Telephone number:			
Address:							
Boiler make and model:							
Boiler serial number:							
Commissioned by (PRINT NAME):				Gas Safe register number:			
Company name:				Telephone number:			
Company address:							
Commissioning date:							
To be completed by the customer on receipt of a Building Regulations Compliance Certificate*							
Building Regulations Notification Number (if applicable):							
CONTROLS (tick the appropriate boxes)							
Time and temperature control to heating		Room thermostat and programmer/timer		Load/weather compensation		Programmable room thermostat	
						Optimum start control	
Time and temperature control to hot water		Cylinder thermostat and programmer/timer				Combination Boiler	
Heating zone valves		Fitted				Not required	
Hot water zone valves		Fitted				Not required	
Thermostatic radiator valves		Fitted				Not required	
Automatic bypass to system		Fitted				Not required	
Boiler interlock						Provided	
ALL SYSTEMS							
The system has been flushed and cleaned in accordance with BS7593 and boiler manufacturer's instructions							Yes
What system cleaner was used?							
What inhibitor was used?							Quantity
							litres
Has a primary water system filter been installed?							Yes
							No
CENTRAL HEATING MODE measure and record:							
Gas rate		m ³ /hr		OR		ft ³ /hr	
Burner operating pressure (if applicable)		mbar		OR Gas inlet pressure		mbar	
Central heating flow temperature							°C
Central heating return temperature							°C
COMBINATION BOILERS ONLY							
Is the installation in a hard water area (above 200ppm)?							Yes
							No
If yes, and if required by the manufacturer, has a water scale reducer been fitted?							Yes
							No
What type of scale reducer has been fitted?							
DOMESTIC HOT WATER MODE Measure and Record:							
Gas rate		m ³ /hr		OR		ft ³ /hr	
Burner operating pressure (at maximum rate)		mbar		OR Gas inlet pressure at maximum rate		mbar	
Cold water inlet temperature							°C
Hot water has been checked at all outlets							Yes
							Temperature
Water flow rate							l/min
CONDENSING BOILERS ONLY							
The condensate drain has been installed in accordance with the manufacturer's instructions and/or BS5546/BS6798							Yes
ALL INSTALLATIONS							
Record the following:		At max. rate:		CO		ppm	
		AND		CO/CO ₂		Ratio	
		At min. rate: (where possible)		CO		ppm	
		AND		CO/CO ₂		Ratio	
The heating and hot water system complies with the appropriate Building Regulations							Yes
The boiler and associated products have been installed and commissioned in accordance with the manufacturer's instructions							Yes
The operation of the boiler and system controls have been demonstrated to and understood by the customer							Yes
The manufacturer's literature, including Benchmark Checklist and Service Record, has been explained and left with the customer							Yes
Commissioning Engineer's Signature							
Customer's Signature							
(To confirm satisfactory demonstration and receipt of manufacturer's literature)							

*All installations in England and Wales must be notified to Local Authority Building Control (LABC) either directly or through a Competent Persons Scheme. A Building Regulations Compliance Certificate will then be issued to the customer.



SERVICE RECORD

It is recommended that your heating system is serviced regularly and that the appropriate Service Interval Record is completed.

Service Provider

Before completing the appropriate Service Record below, please ensure you have carried out the service as described in the manufacturer's instructions. Always use the manufacturer's specified spare part when replacing controls.

<table border="1" style="width: 100%; border-collapse: collapse;"> <tr> <td colspan="2">SERVICE 01</td> <td colspan="2">Date:</td> </tr> <tr><td colspan="4">Engineer name:</td></tr> <tr><td colspan="4">Company name:</td></tr> <tr><td colspan="4">Telephone No:</td></tr> <tr><td colspan="4">Gas safe register No:</td></tr> <tr> <td>Record:</td> <td>At max. rate:</td> <td>CO ppm</td> <td>AND CO₂ %</td> </tr> <tr> <td></td> <td>At min. rate: (Where Possible)</td> <td>CO ppm</td> <td>AND CO₂ %</td> </tr> <tr><td colspan="4">Comments:</td></tr> <tr><td colspan="4"> </td></tr> <tr><td colspan="4">Signature</td></tr> </table>	SERVICE 01		Date:		Engineer name:				Company name:				Telephone No:				Gas safe register No:				Record:	At max. rate:	CO ppm	AND CO ₂ %		At min. rate: (Where Possible)	CO ppm	AND CO ₂ %	Comments:								Signature				<table border="1" style="width: 100%; border-collapse: collapse;"> <tr> <td colspan="2">SERVICE 02</td> <td colspan="2">Date:</td> </tr> <tr><td colspan="4">Engineer name:</td></tr> <tr><td colspan="4">Company name:</td></tr> <tr><td colspan="4">Telephone No:</td></tr> <tr><td colspan="4">Gas safe register No:</td></tr> <tr> <td>Record:</td> <td>At max. rate:</td> <td>CO ppm</td> <td>AND CO₂ %</td> </tr> <tr> <td></td> <td>At min. rate: (Where Possible)</td> <td>CO ppm</td> <td>AND CO₂ %</td> </tr> <tr><td colspan="4">Comments:</td></tr> <tr><td colspan="4"> </td></tr> <tr><td colspan="4">Signature</td></tr> </table>	SERVICE 02		Date:		Engineer name:				Company name:				Telephone No:				Gas safe register No:				Record:	At max. rate:	CO ppm	AND CO ₂ %		At min. rate: (Where Possible)	CO ppm	AND CO ₂ %	Comments:								Signature			
SERVICE 01		Date:																																																																															
Engineer name:																																																																																	
Company name:																																																																																	
Telephone No:																																																																																	
Gas safe register No:																																																																																	
Record:	At max. rate:	CO ppm	AND CO ₂ %																																																																														
	At min. rate: (Where Possible)	CO ppm	AND CO ₂ %																																																																														
Comments:																																																																																	
Signature																																																																																	
SERVICE 02		Date:																																																																															
Engineer name:																																																																																	
Company name:																																																																																	
Telephone No:																																																																																	
Gas safe register No:																																																																																	
Record:	At max. rate:	CO ppm	AND CO ₂ %																																																																														
	At min. rate: (Where Possible)	CO ppm	AND CO ₂ %																																																																														
Comments:																																																																																	
Signature																																																																																	
<table border="1" style="width: 100%; border-collapse: collapse;"> <tr> <td colspan="2">SERVICE 03</td> <td colspan="2">Date:</td> </tr> <tr><td colspan="4">Engineer name:</td></tr> <tr><td colspan="4">Company name:</td></tr> <tr><td colspan="4">Telephone No:</td></tr> <tr><td colspan="4">Gas safe register No:</td></tr> <tr> <td>Record:</td> <td>At max. rate:</td> <td>CO ppm</td> <td>AND CO₂ %</td> </tr> <tr> <td></td> <td>At min. rate: (Where Possible)</td> <td>CO ppm</td> <td>AND CO₂ %</td> </tr> <tr><td colspan="4">Comments:</td></tr> <tr><td colspan="4"> </td></tr> <tr><td colspan="4">Signature</td></tr> </table>	SERVICE 03		Date:		Engineer name:				Company name:				Telephone No:				Gas safe register No:				Record:	At max. rate:	CO ppm	AND CO ₂ %		At min. rate: (Where Possible)	CO ppm	AND CO ₂ %	Comments:								Signature				<table border="1" style="width: 100%; border-collapse: collapse;"> <tr> <td colspan="2">SERVICE 04</td> <td colspan="2">Date:</td> </tr> <tr><td colspan="4">Engineer name:</td></tr> <tr><td colspan="4">Company name:</td></tr> <tr><td colspan="4">Telephone No:</td></tr> <tr><td colspan="4">Gas safe register No:</td></tr> <tr> <td>Record:</td> <td>At max. rate:</td> <td>CO ppm</td> <td>AND CO₂ %</td> </tr> <tr> <td></td> <td>At min. rate: (Where Possible)</td> <td>CO ppm</td> <td>AND CO₂ %</td> </tr> <tr><td colspan="4">Comments:</td></tr> <tr><td colspan="4"> </td></tr> <tr><td colspan="4">Signature</td></tr> </table>	SERVICE 04		Date:		Engineer name:				Company name:				Telephone No:				Gas safe register No:				Record:	At max. rate:	CO ppm	AND CO ₂ %		At min. rate: (Where Possible)	CO ppm	AND CO ₂ %	Comments:								Signature			
SERVICE 03		Date:																																																																															
Engineer name:																																																																																	
Company name:																																																																																	
Telephone No:																																																																																	
Gas safe register No:																																																																																	
Record:	At max. rate:	CO ppm	AND CO ₂ %																																																																														
	At min. rate: (Where Possible)	CO ppm	AND CO ₂ %																																																																														
Comments:																																																																																	
Signature																																																																																	
SERVICE 04		Date:																																																																															
Engineer name:																																																																																	
Company name:																																																																																	
Telephone No:																																																																																	
Gas safe register No:																																																																																	
Record:	At max. rate:	CO ppm	AND CO ₂ %																																																																														
	At min. rate: (Where Possible)	CO ppm	AND CO ₂ %																																																																														
Comments:																																																																																	
Signature																																																																																	
<table border="1" style="width: 100%; border-collapse: collapse;"> <tr> <td colspan="2">SERVICE 05</td> <td colspan="2">Date:</td> </tr> <tr><td colspan="4">Engineer name:</td></tr> <tr><td colspan="4">Company name:</td></tr> <tr><td colspan="4">Telephone No:</td></tr> <tr><td colspan="4">Gas safe register No:</td></tr> <tr> <td>Record:</td> <td>At max. rate:</td> <td>CO ppm</td> <td>AND CO₂ %</td> </tr> <tr> <td></td> <td>At min. rate: (Where Possible)</td> <td>CO ppm</td> <td>AND CO₂ %</td> </tr> <tr><td colspan="4">Comments:</td></tr> <tr><td colspan="4"> </td></tr> <tr><td colspan="4">Signature</td></tr> </table>	SERVICE 05		Date:		Engineer name:				Company name:				Telephone No:				Gas safe register No:				Record:	At max. rate:	CO ppm	AND CO ₂ %		At min. rate: (Where Possible)	CO ppm	AND CO ₂ %	Comments:								Signature				<table border="1" style="width: 100%; border-collapse: collapse;"> <tr> <td colspan="2">SERVICE 06</td> <td colspan="2">Date:</td> </tr> <tr><td colspan="4">Engineer name:</td></tr> <tr><td colspan="4">Company name:</td></tr> <tr><td colspan="4">Telephone No:</td></tr> <tr><td colspan="4">Gas safe register No:</td></tr> <tr> <td>Record:</td> <td>At max. rate:</td> <td>CO ppm</td> <td>AND CO₂ %</td> </tr> <tr> <td></td> <td>At min. rate: (Where Possible)</td> <td>CO ppm</td> <td>AND CO₂ %</td> </tr> <tr><td colspan="4">Comments:</td></tr> <tr><td colspan="4"> </td></tr> <tr><td colspan="4">Signature</td></tr> </table>	SERVICE 06		Date:		Engineer name:				Company name:				Telephone No:				Gas safe register No:				Record:	At max. rate:	CO ppm	AND CO ₂ %		At min. rate: (Where Possible)	CO ppm	AND CO ₂ %	Comments:								Signature			
SERVICE 05		Date:																																																																															
Engineer name:																																																																																	
Company name:																																																																																	
Telephone No:																																																																																	
Gas safe register No:																																																																																	
Record:	At max. rate:	CO ppm	AND CO ₂ %																																																																														
	At min. rate: (Where Possible)	CO ppm	AND CO ₂ %																																																																														
Comments:																																																																																	
Signature																																																																																	
SERVICE 06		Date:																																																																															
Engineer name:																																																																																	
Company name:																																																																																	
Telephone No:																																																																																	
Gas safe register No:																																																																																	
Record:	At max. rate:	CO ppm	AND CO ₂ %																																																																														
	At min. rate: (Where Possible)	CO ppm	AND CO ₂ %																																																																														
Comments:																																																																																	
Signature																																																																																	
<table border="1" style="width: 100%; border-collapse: collapse;"> <tr> <td colspan="2">SERVICE 07</td> <td colspan="2">Date:</td> </tr> <tr><td colspan="4">Engineer name:</td></tr> <tr><td colspan="4">Company name:</td></tr> <tr><td colspan="4">Telephone No:</td></tr> <tr><td colspan="4">Gas safe register No:</td></tr> <tr> <td>Record:</td> <td>At max. rate:</td> <td>CO ppm</td> <td>AND CO₂ %</td> </tr> <tr> <td></td> <td>At min. rate: (Where Possible)</td> <td>CO ppm</td> <td>AND CO₂ %</td> </tr> <tr><td colspan="4">Comments:</td></tr> <tr><td colspan="4"> </td></tr> <tr><td colspan="4">Signature</td></tr> </table>	SERVICE 07		Date:		Engineer name:				Company name:				Telephone No:				Gas safe register No:				Record:	At max. rate:	CO ppm	AND CO ₂ %		At min. rate: (Where Possible)	CO ppm	AND CO ₂ %	Comments:								Signature				<table border="1" style="width: 100%; border-collapse: collapse;"> <tr> <td colspan="2">SERVICE 08</td> <td colspan="2">Date:</td> </tr> <tr><td colspan="4">Engineer name:</td></tr> <tr><td colspan="4">Company name:</td></tr> <tr><td colspan="4">Telephone No:</td></tr> <tr><td colspan="4">Gas safe register No:</td></tr> <tr> <td>Record:</td> <td>At max. rate:</td> <td>CO ppm</td> <td>AND CO₂ %</td> </tr> <tr> <td></td> <td>At min. rate: (Where Possible)</td> <td>CO ppm</td> <td>AND CO₂ %</td> </tr> <tr><td colspan="4">Comments:</td></tr> <tr><td colspan="4"> </td></tr> <tr><td colspan="4">Signature</td></tr> </table>	SERVICE 08		Date:		Engineer name:				Company name:				Telephone No:				Gas safe register No:				Record:	At max. rate:	CO ppm	AND CO ₂ %		At min. rate: (Where Possible)	CO ppm	AND CO ₂ %	Comments:								Signature			
SERVICE 07		Date:																																																																															
Engineer name:																																																																																	
Company name:																																																																																	
Telephone No:																																																																																	
Gas safe register No:																																																																																	
Record:	At max. rate:	CO ppm	AND CO ₂ %																																																																														
	At min. rate: (Where Possible)	CO ppm	AND CO ₂ %																																																																														
Comments:																																																																																	
Signature																																																																																	
SERVICE 08		Date:																																																																															
Engineer name:																																																																																	
Company name:																																																																																	
Telephone No:																																																																																	
Gas safe register No:																																																																																	
Record:	At max. rate:	CO ppm	AND CO ₂ %																																																																														
	At min. rate: (Where Possible)	CO ppm	AND CO ₂ %																																																																														
Comments:																																																																																	
Signature																																																																																	
<table border="1" style="width: 100%; border-collapse: collapse;"> <tr> <td colspan="2">SERVICE 09</td> <td colspan="2">Date:</td> </tr> <tr><td colspan="4">Engineer name:</td></tr> <tr><td colspan="4">Company name:</td></tr> <tr><td colspan="4">Telephone No:</td></tr> <tr><td colspan="4">Gas safe register No:</td></tr> <tr> <td>Record:</td> <td>At max. rate:</td> <td>CO ppm</td> <td>AND CO₂ %</td> </tr> <tr> <td></td> <td>At min. rate: (Where Possible)</td> <td>CO ppm</td> <td>AND CO₂ %</td> </tr> <tr><td colspan="4">Comments:</td></tr> <tr><td colspan="4"> </td></tr> <tr><td colspan="4">Signature</td></tr> </table>	SERVICE 09		Date:		Engineer name:				Company name:				Telephone No:				Gas safe register No:				Record:	At max. rate:	CO ppm	AND CO ₂ %		At min. rate: (Where Possible)	CO ppm	AND CO ₂ %	Comments:								Signature				<table border="1" style="width: 100%; border-collapse: collapse;"> <tr> <td colspan="2">SERVICE 10</td> <td colspan="2">Date:</td> </tr> <tr><td colspan="4">Engineer name:</td></tr> <tr><td colspan="4">Company name:</td></tr> <tr><td colspan="4">Telephone No:</td></tr> <tr><td colspan="4">Gas safe register No:</td></tr> <tr> <td>Record:</td> <td>At max. rate:</td> <td>CO ppm</td> <td>AND CO₂ %</td> </tr> <tr> <td></td> <td>At min. rate: (Where Possible)</td> <td>CO ppm</td> <td>AND CO₂ %</td> </tr> <tr><td colspan="4">Comments:</td></tr> <tr><td colspan="4"> </td></tr> <tr><td colspan="4">Signature</td></tr> </table>	SERVICE 10		Date:		Engineer name:				Company name:				Telephone No:				Gas safe register No:				Record:	At max. rate:	CO ppm	AND CO ₂ %		At min. rate: (Where Possible)	CO ppm	AND CO ₂ %	Comments:								Signature			
SERVICE 09		Date:																																																																															
Engineer name:																																																																																	
Company name:																																																																																	
Telephone No:																																																																																	
Gas safe register No:																																																																																	
Record:	At max. rate:	CO ppm	AND CO ₂ %																																																																														
	At min. rate: (Where Possible)	CO ppm	AND CO ₂ %																																																																														
Comments:																																																																																	
Signature																																																																																	
SERVICE 10		Date:																																																																															
Engineer name:																																																																																	
Company name:																																																																																	
Telephone No:																																																																																	
Gas safe register No:																																																																																	
Record:	At max. rate:	CO ppm	AND CO ₂ %																																																																														
	At min. rate: (Where Possible)	CO ppm	AND CO ₂ %																																																																														
Comments:																																																																																	
Signature																																																																																	

*All installations in England and Wales must be notified to Local Authority Building Control (LABC) either directly or through a Competent Persons Scheme. A Building Regulations Compliance Certificate will then be issued to the customer.



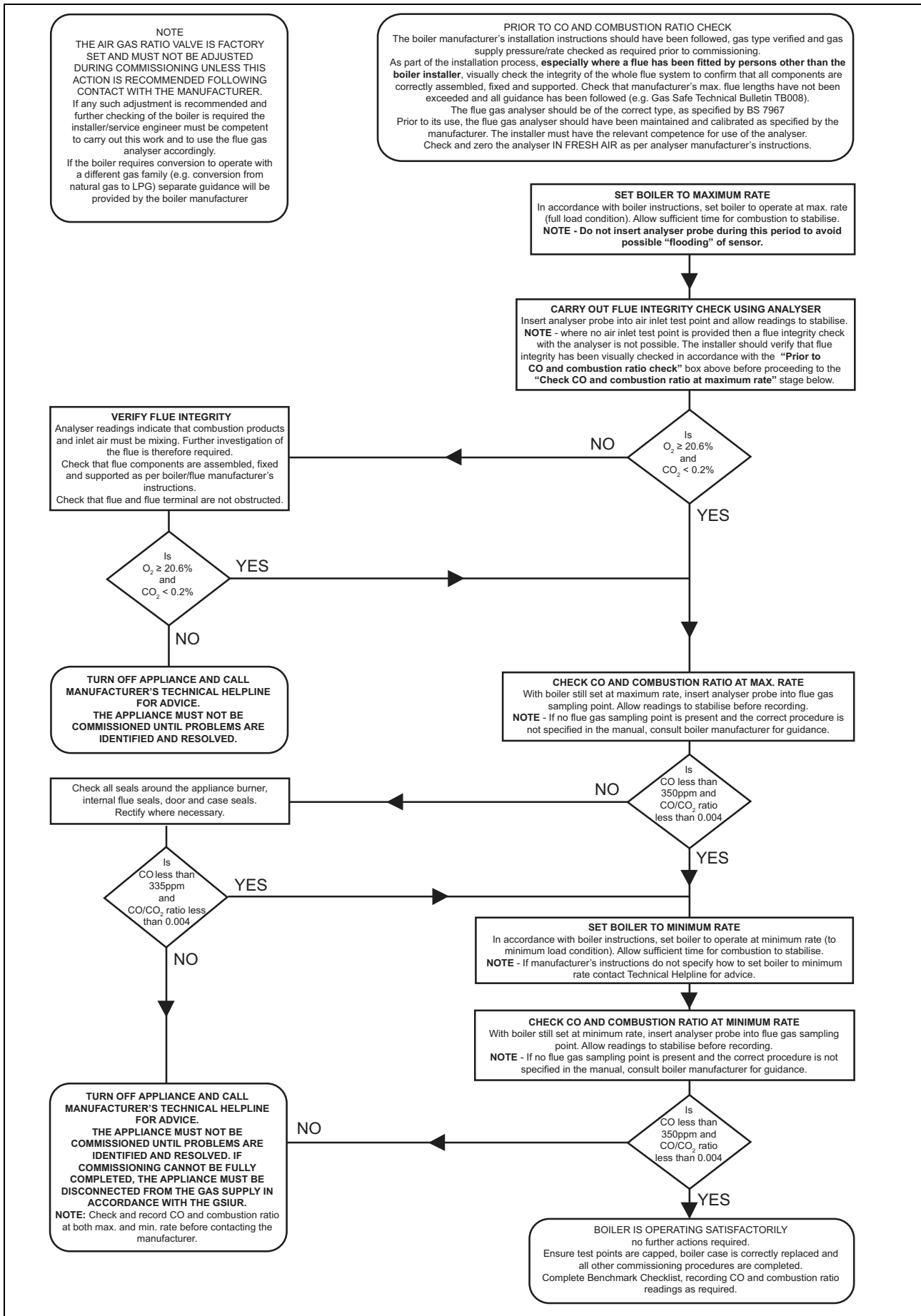

G Opening of the flue pipe

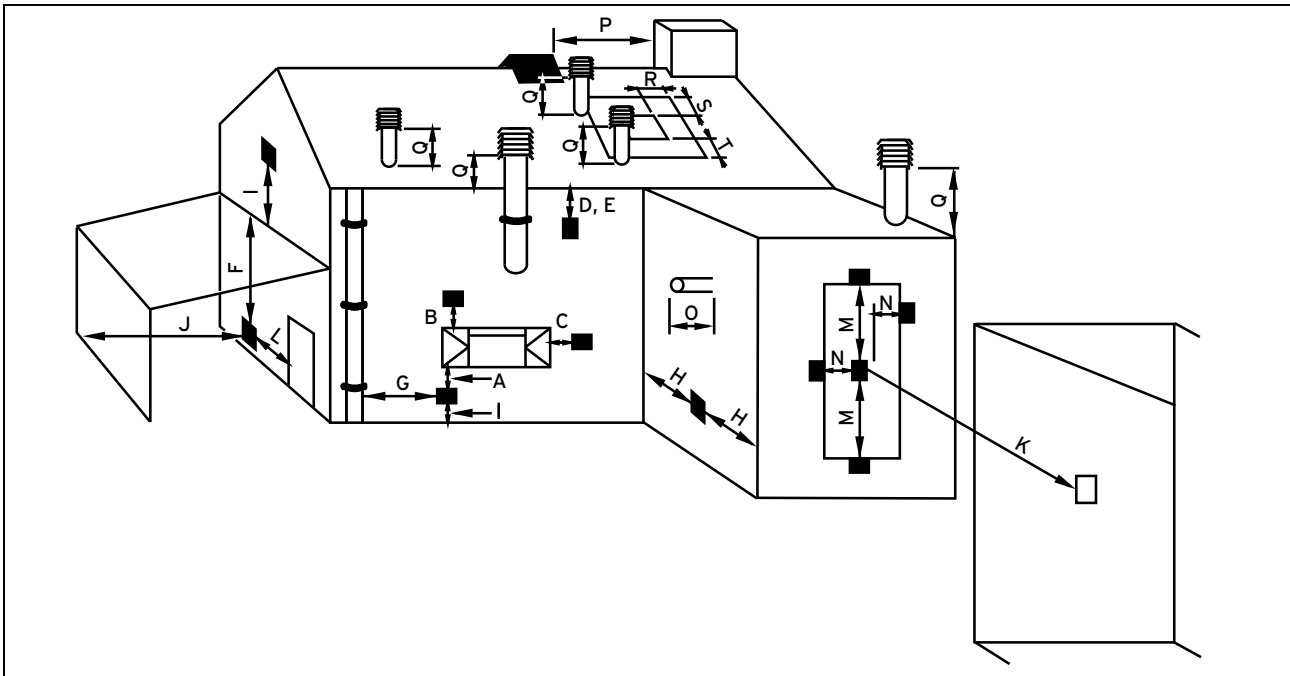

G.1 Positioning of the opening of a fan-supported flue gas pipe

	Installation site	Minimum dimensions
A	Directly below an opening, air bricks, opening windows, etc., that can be opened.	300 mm
B	Above an opening, air bricks, opening windows, etc., that can be opened.	300 mm
C	Horizontally to an opening, air bricks, opening windows, etc., that can be opened.	300 mm
D	Below temperature-sensitive building components, e.g. plastic gutters, down pipes or wastewater pipes	75 mm
E	Below eaves	200 mm
F	Below balconies or car port roofs	200 mm
G	From vertical wastewater pipes or down pipes	150 mm
H	From external or internal corners	200 mm
I	Above floors, roofs or balconies	300 mm
J	From a surface facing a terminal	600 mm
K	From a terminal facing a terminal	1200 mm
L	From an opening in the car port (e.g. door, window) which leads into the dwelling	1200 mm
M	Vertical from a terminal on the same wall	1500 mm
N	Horizontal from a terminal on the same wall	300 mm
O	From the wall on which the terminal has been installed	0 mm
P	From a vertical structure on the roof	N/A
Q	Above the roof area	300 mm
R	Horizontal from adjacent windows on pitched or flat roofs	600 mm
S	Above adjacent windows on pitched or flat roofs	600 mm
T	Below adjacent windows on pitched or flat roofs	2000 mm

H Text from BS 5440-1 on fan-supported flue gas pipes

BS 5440-1: It is recommended that the fanned flue gas system terminal is positioned as follows:

- At least 2 m from an opening in the building directly opposite, and
- So that the combustion products are not discharged directly across a property boundary.
- Dimensions D, E, F and G: These clearances may be reduced to 25 mm without affecting the performance of the boiler. In order to ensure that the condensate vapour plume does not damage adjacent surfaces, the terminal should be extended as shown.
- Dimension H: This clearance may be reduced to 25 mm without adversely affecting the performance of the boiler. However, in order to ensure that the condensate vapour plume does not damage adjacent surfaces, a clearance of 300 mm is preferred. For IE, recommendations are given in the current issue of the IS 813.

I Opening of the flue pipe below eaves and balconies

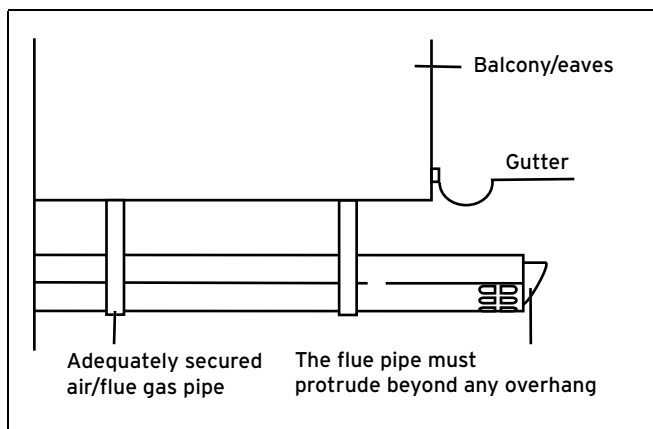

J Technical data

Technical data – General

	24 (VUW GB 246/5-3 A) ecoTEC pro	28 (VUW GB 286/5-3 A) ecoTEC pro	30 (VUW GB 306/5-3) ecoTEC pro
Designated country (designation in accordance with ISO 3166)	GB (Great Britain), IE (Ireland)	GB (Great Britain), IE (Ireland)	GB (Great Britain), IE (Ireland)
Approved unit categories	II _{2H3P}	II _{2H3P}	II _{2H3P}
Gas connection, boiler side	15 mm	15 mm	15 mm
Flow/return heating connections, boiler side	22 mm	22 mm	22 mm
Hot and cold water connection, boiler side	G 3/4"	G 3/4"	G 3/4"
Expansion relief valve connector (min.)	15 mm	15 mm	15 mm
Air/flue gas connection	60/100 mm	60/100 mm	60/100 mm
Condensate drain pipe-work (min.)	19 mm	19 mm	19 mm
G20 natural gas flow pressure	2.0 kPa (20.0 mbar)	2.0 kPa (20.0 mbar)	2.0 kPa (20.0 mbar)
G31 propane gas flow pressure	3.7 kPa (37.0 mbar)	3.7 kPa (37.0 mbar)	3.7 kPa (37.0 mbar)
Gas flow rate at 15 °C and 1013 mbar (based on hot water generation, if applicable), G20	2.5 m ³ /h	2.9 m ³ /h	3.2 m ³ /h

Appendix

	24 (VUW GB 246/5-3 A) ecoTEC pro	28 (VUW GB 286/5-3 A) ecoTEC pro	30 (VUW GB 306/5-3) ecoTEC pro
Gas flow rate at 15 °C and 1013 mbar (based on hot water generation, if applicable), G31	1.9 kg/h	2.2 kg/h	2.4 kg/h
Min. flue gas mass rate (G20)	2.47 g/s	2.47 g/s	2.96 g/s
Min. flue gas mass rate (G31)	3.49 g/s	3.49 g/s	3.94 g/s
Max. flue gas mass rate	10.8 g/s	12.6 g/s	13.9 g/s
Min. flue gas temperature	40 °C	40 °C	40 °C
Max. flue gas temperature	70 °C	70 °C	70 °C
Approved gas-fired units	C13, C33, C43, C53	C13, C33, C43, C53	C13, C33, C43, C53
30% efficiency	108 %	108 %	108 %
NOx class	5	5	5
SEDBUK (2005)	A	A	A
SEDBUK (2009) (G20/G31)	89.3 %	89.3 %	89.3 %
Boiler dimension, width	440 mm	440 mm	440 mm
Boiler dimension, height	720 mm	720 mm	720 mm
Boiler dimension, depth	338 mm	338 mm	338 mm
Approx. net weight	38 kg	38 kg	39 kg

Technical data – G20 power/loading G20

	24 (VUW GB 246/5-3 A) ecoTEC pro	28 (VUW GB 286/5-3 A) ecoTEC pro	30 (VUW GB 306/5-3) ecoTEC pro
Nominal heat output range P at 50/30 °C	5.7 ... 19.9 kW	5.7 ... 19.9 kW	6.9 ... 25.7 kW
Nominal heat output range P at 80/60 °C	5.2 ... 18.9 kW	5.2 ... 18.9 kW	8.0 ... 24.7 kW
Maximum heat output for hot water generation	23.4 kW	27.2 kW	30.0 kW
Maximum heat input for hot water generation	23.7 kW	27.8 kW	30.6 kW
Maximum heat input, heating side	19.1 kW	19.1 kW	25.0 kW
Minimum heat input	5.5 kW	5.5 kW	8.5 kW
Heating adjustment range	5 ... 19 kW	5 ... 19 kW	6 ... 24 kW

Technical data – Power/loading G31

	24 (VUW GB 246/5-3 A) ecoTEC pro	28 (VUW GB 286/5-3 A) ecoTEC pro	30 (VUW GB 306/5-3) ecoTEC pro
Nominal heat output range P at 50/30 °C	5.7 ... 19.9 kW	6.9 ... 25.7 kW	9.0 ... 25.7 kW
Nominal heat output range P at 80/60 °C	5.2 ... 18.9 kW	5.2 ... 18.9 kW	6.2 ... 24.4 kW
Maximum heat output for hot water generation	23.4 kW	27.2 kW	30.0 kW
Maximum heat input for hot water generation	23.7 kW	27.8 kW	30.6 kW

	24 (VUW GB 246/5-3 A) ecoTEC pro	28 (VUW GB 286/5-3 A) ecoTEC pro	30 (VUW GB 306/5-3) ecoTEC pro
Maximum heat input, heating side	19.1 kW	18.8 kW	25.0 kW
Minimum heat input	7.7 kW	7.7 kW	8.7 kW

Technical data – Heating

	24 (VUW GB 246/5-3 A) ecoTEC pro	28 (VUW GB 286/5-3 A) ecoTEC pro	30 (VUW GB 306/5-3) ecoTEC pro
Maximum flow temperature	85 °C	85 °C	85 °C
Max. flow temperature adjustment range (default setting: 75 °C)	30 ... 80 °C	30 ... 80 °C	30 ... 80 °C
Permissible total over- pressure	0.3 MPa (3.0 bar)	0.3 MPa (3.0 bar)	0.3 MPa (3.0 bar)
Minimum pressure for full operation	0.08 MPa (0.80 bar)	0.08 MPa (0.80 bar)	0.08 MPa (0.80 bar)
Expansion vessel capa- city	10 l	10 l	10 l
Circulation water volume (with reference to $\Delta T = 20$ K)	813 l/h	813 l/h	1,049 l/h
Approx. condensate rate (pH value 3.5 to 4.0) in 50/30 °C heating mode	1.9 l/h	1.9 l/h	2.5 l/h
Remaining feed head of pump (at nominal circula- tion water volume)	0.025 MPa (0.250 bar)	0.025 MPa (0.250 bar)	0.025 MPa (0.250 bar)

Technical data – Hot water handling

	24 (VUW GB 246/5-3 A) ecoTEC pro	28 (VUW GB 286/5-3 A) ecoTEC pro	30 (VUW GB 306/5-3) ecoTEC pro
Lowest water volume	2.0 l/min	2.0 l/min	2.0 l/min
Water volume (at $\Delta T = 30$ K)	11.0 l/min	13.4 l/min	14.3 l/min
Water volume (at $\Delta T = 35$ K)	9.6 l/min	11.1 l/min	12.3 l/min
Water volume (at $\Delta T = 42$ K)	8.0 l/min	9.3 l/min	10.2 l/min
Permitted overpressure	1.0 MPa (10.0 bar)	1.0 MPa (10.0 bar)	1.0 MPa (10.0 bar)
Required connection pressure	0.035 MPa (0.350 bar)	0.035 MPa (0.350 bar)	0.035 MPa (0.350 bar)
Hot water output temper- ature range	35 ... 65 °C	35 ... 65 °C	35 ... 65 °C

Technical data – Electrics

	24 (VUW GB 246/5-3 A) ecoTEC pro	28 (VUW GB 286/5-3 A) ecoTEC pro	30 (VUW GB 306/5-3) ecoTEC pro
Electric connection	230 V/50 Hz	230 V/50 Hz	230 V/50 Hz
Permissible connected voltage	190 ... 253 V	190 ... 253 V	190 ... 253 V
Built-in fuse (slow-blow)	2 A	2 A	2 A
Min. electrical power con- sumption	35 W	35 W	35 W

Appendix

	24 (VUW GB 246/5-3 A) ecoTEC pro	28 (VUW GB 286/5-3 A) ecoTEC pro	30 (VUW GB 306/5-3) ecoTEC pro
Max. electrical power consumption	50 W	80 W	80 W
Standby electrical power consumption	< 2 W	< 2 W	< 2 W
Level of protection	IP X4 D	IP X4 D	IP X4 D
Test symbol/registration no.	CE-0085CM0320	CE-0085CM0320	CE-0085CM0320

Index

6	
60/100 mm diameter unit connection piece with offset, installing	15
8	
80/125 mm diameter unit connection piece, installing	15
A	
Air index setting	22
Air/flue pipe	14
Air/flue pipe, installed	5
Article number	9
Automatic air vent	19
B	
Burner anti-cycling time	23
Burner anti-cycling time, resetting	24
Burner anti-cycling time, setting	23
Burner, checking	29
Bypass valve, setting	24
C	
Calling up, diagnostics codes	23
Calling up, fault memory	25
Carrying out, inspection work	28
Carrying out, maintenance work	28
CE label	9
Check programmes	18
Checking, burner	29
Checking, CO ₂ content	22
Checking, pre-charge pressure for the internal expansion vessel	30
Circulation pump	17
Cleaning, cold water inlet filter	29
Cleaning, heat exchanger	29
Clearing, fault memory	25
CO ₂ content, checking	22
CO ₂ content, setting	22
Cold water connection	13
Cold water inlet filter, cleaning	29
Combustion air	6
Comfort protection mode	25
Compact thermal module, installing	30
Compact thermal module, removing	28
Completing, inspection work	30
Completing, maintenance work	30
Completing, repair work	27
Condensate drain pipework	14
Condensate siphon	20, 29
Condensate trap	20, 29
Connecting, controller	16
Connection dimensions	10
Controller, connecting	16
Corrosion	6
D	
Decommissioning	30
Decommissioning, temporarily	30
Diagnostics codes, calling up	23
Discharge pipe, expansion relief valve	14
Disposal, packaging	30
Disposing of the packaging	30
Documents	8
Draining, product	30
E	
Electricity	5
Electronics box, closing	15
Electronics box, opening	15
F	
Fan, replacing	26
Fault codes	25, 35
Fault memory, calling up	25
Fault memory, deleting	25
Fault messages	25
Filling	19
Flue gas route	5
Flue pipe equipment connection piece	15
From the delivery point to the installation site	10
Front casing, closed	5
Frost	6
G	
Gas conversion	20
Gas ratio setting	20
Gas valve, replacing	26
H	
Handing over to the operator	25
Handling	9
Heat exchanger, cleaning	29
Heat exchanger, replacing	26
Heating flow	13
Heating installation, purging	20
Heating return	13
Hot water connection	13
I	
Identification plate	8
If you smell gas	4
Inspection work, carrying out	28
Inspection work, completing	30
Installation site	5–6
Installer level	17
Installer level, calling up	17
Installing, compact thermal module	30
Intended use	4
Internal expansion vessel, replacing	27
Isolator devices	30
L	
Liquid gas	4, 12
M	
Mains connection	16
Maintenance interval, setting	24
Maintenance work, carrying out	28
Maintenance work, completing	30
Minimum clearance	11
O	
Operating concept	17
P	
PCB and display, replacing	27
PCB or display, replacing	27
Power supply	16
Pre-charge pressure for the internal expansion vessel, checking	30
Preparing, repair work	25
Pressure gauge	8
Product dimensions	10
Product, draining	30
Product, switching off	18, 30

Index

Product, switching on	18
Pump output, setting	24
Pump, remaining feed head	24
Purging, heating installation	20
R	
Read-off and setting options	17
Remaining feed head, pump	24
Removing, compact thermal module	28
Repair work, completing	27
Repair work, preparing	25
Replacing the burner	25
Replacing, fan	26
Replacing, gas valve	26
Replacing, heat exchanger	26
Replacing, internal expansion vessel	27
Replacing, PCB and display	27
Replacing, PCB or display	27
S	
Safety device	5
Schematic drawing	5
Scope of delivery	9
Serial number	9
Service message	25
Setting, bypass valve	24
Setting, CO ₂ content	22
Setting, maintenance interval	24
Setting, pump output	24
Side section, installing	12
Side section, removing	12
Spare parts	25
Status codes	17, 34
Supply of combustion air	5
Switching off	30
Switching off, product	18
Switching on, product	18
T	
Tool	6
Treating the heating water	18
U	
Unit connection piece for the air/flue pipe, 60/100 mm diameter with offset	15
Unit connection piece for the air/flue pipe, 80/125 mm diameter	15
Unit connection piece, changing	15
Unit connection piece, removing	15
Unloading the box	10
V	
Voltage	5
W	
Weight	11

0020209589_01 ■ 04.09.2015

Vaillant Ltd.

Nottingham Road ■ Belper ■ Derbyshire ■ DE56 1JT

Telephone 0330 100 3461 ■ Telephone (renewables) 0207 022 0928

Vaillant Service Solutions 0330 100 3461 ■ Spares Technical Enquiries 01773 596615

info@vaillant.co.uk ■ technicalspares@groupservice.co.uk

www.vaillant.co.uk

© These instructions, or parts thereof, are protected by copyright and may be reproduced or distributed only with the manufacturer's written consent.