

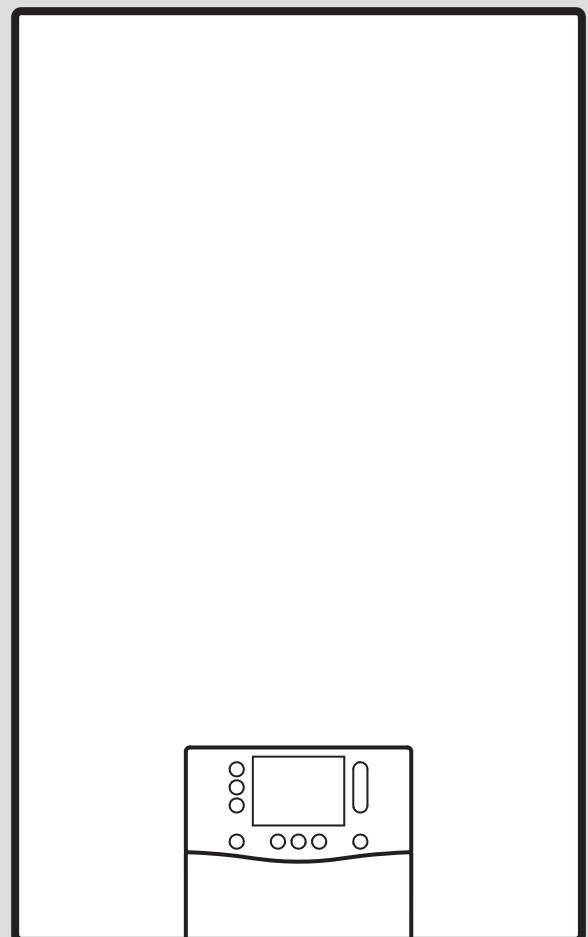

ecoTEC plus

VU../VUW..



Installation and maintenance instructions

Contents

1	Safety	4	8.6	Calling up the data overview	39
1.1	Intended use	4	8.7	Calling up status codes.....	39
1.2	Qualification	4	8.8	Exiting the menu level.....	39
1.3	General safety information	4	8.9	Running the chimney sweep mode (combustion analysis).....	39
1.4	Regulations (directives, laws, standards).....	7	8.10	Switching on the button lock (Advanced Key Lock).....	39
1.5	List of relevant standards for Great Britain and Ireland.....	7	9	Start-up	39
2	Guarantee and Customer Service	8	9.1	Pre-Commissioning checklist	39
3	Technical data	9	9.2	Carrying out the initial start-up.....	40
4	Notes on the documentation	16	9.3	Checking and treating the heating water/filling and supplementary water	40
5	Product description	16	9.4	Deactivating standby mode	41
5.1	CE marking	16	9.5	Running through the installation assistant.....	41
5.2	UKCA mark.....	16	9.6	Check programmes and actuator tests.....	42
5.3	Hot Water Association	16	9.7	Guaranteeing the system pressure	42
5.4	Water Regulations Advisory Scheme	16	9.8	Flushing the heating installation for the first time ("cold")	42
5.5	Data plate	17	9.9	Filling the heating installation	43
5.6	Serial number	17	9.10	Purging the heating installation	43
5.7	Sitherm Pro™ technology.....	17	9.11	Filling and purging the domestic hot water system	43
5.8	Display of the energy consumption, energy yields and efficiencies.....	17	9.12	Filling the condensate siphon	44
5.9	Product design.....	18	9.13	Checking the gas settings	44
5.10	Design of the product's hydraulic block	19	9.14	Thoroughly flushing the heating installation ("hot").....	47
5.11	Safety Devices.....	19	9.15	Checking the heating mode	48
6	Set-up	19	9.16	Checking the domestic hot water generation	48
6.1	Checking the scope of delivery.....	19	9.17	Checking leak-tightness	48
6.2	Product dimensions	20	9.18	Converting the product to a different gas type.....	48
6.3	Installation site	20	10	Adapting the unit to the installation	48
6.4	Minimum clearances.....	21	10.1	Setting parameters	48
6.5	Compartment Ventilation	21	10.2	Activating an additional component for the multi-functional module.....	48
6.6	Using the mounting template	21	10.3	Adapting the heating mode settings	49
6.7	Wall-mounting the product.....	21	10.4	Adapting the domestic hot water settings.....	53
7	Installation	21	10.5	Displaying the product information	53
7.1	Prerequisites.....	21	11	Handing over to the end user	53
7.2	Installing the air/flue pipe.....	23	12	Inspection and maintenance	54
7.3	Installing the gas connection	27	12.1	Complete Service Interval Record section	54
7.4	Installing the hot and cold water connection.....	28	12.2	Using original seals.....	54
7.5	Connecting the domestic hot water cylinder.....	28	12.3	Maintenance interval.....	54
7.6	Installing the heating flow and heating return	28	12.4	Actuator test.....	54
7.7	Installing the heating flow and heating return	28	12.5	Inspection and maintenance.....	54
7.8	Installing the condensate discharge	28	12.6	Preparing the maintenance work.....	54
7.9	Installing combined condensate and pressure relief valve.....	31	12.7	Removing/installing the compact thermal module	55
7.10	Electrical installation	31	12.8	Cleaning/checking the components.....	56
7.11	Installing the front casing.....	38	12.9	Draining the product	58
8	Operation	38	12.10	Completing inspection and maintenance work	59
8.1	Operating concept	38	13	Troubleshooting	59
8.2	Calling up the installer level.....	38	13.1	Checking the data overview	59
8.3	Calling up/setting diagnostics codes	38	13.2	Service messages	59
8.4	Running a check programme	38	13.3	Fault messages	59
8.5	Carrying out the actuator test	39	13.4	Limp home mode messages	59

13.5	Resetting parameters to factory settings	59
13.6	Eliminating faults in the product.....	60
13.7	Replacing defective components.....	60
14	Decommissioning.....	68
14.1	Activate the standby mode	68
14.2	Temporarily decommissioning.....	68
14.3	Permanently decommissioning.....	68
15	Disposing of the packaging.....	68
Appendix		69
A	Tightening torques	69
B	Inspection and maintenance work.....	69
C	Installer level	71
D	Diagnostics codes	72
E	Status codes	79
F	Fault codes.....	80
G	Check programmes	91
H	Actuator test.....	91
I	Maintenance codes.....	92
J	Reversible limp home mode codes	92
K	Irreversible limp home mode codes	92
L	Wiring diagram.....	95
M	Commissioning Checklist.....	104
N	Commissioning Flow Chart	108
Index		109



1 Safety

1.1 Intended use

The product is intended as a heat generator for sealed heating installations and for domestic hot water generation.

Improper use of any kind is prohibited.

Intended use also includes the following:

- use of the product only in mobile homes that are made, transported once and permanently situated in Great Britain and Ireland. After the transportation of the mobile home to its destination the complete product must be checked for leak-tightness again
- validity of the product only for Great Britain and Ireland and for the gas types in Great Britain and Ireland as listed on the data plate
- Installing and operating the product only in conjunction with accessories for the air/flue pipe which are listed in the other applicable documents and comply with the type of unit
- Using the product while observing the accompanying operating, installation and maintenance instructions for the product along with all other components of the installation
- Installing and setting up the product while observing the product and system approval
- Observing all inspection and maintenance conditions listed in the instructions
- Installing while observing the IP code

The following is classed as improper use:

- Using the product in vehicles, such as caravans. Units that are not classed as vehicles are those that are installed in a fixed and permanent location (known as "fixed installation").
- Using the product in combination with directly connected wall-hung domestic hot water cylinders, whether in the case of a replacement or for a new installation.
- Using the product for a multiple-flue configuration or as a cascade
- Any direct use in industrial or commercial processes

- Any use other than those described in these instructions and any use that goes beyond what is described here

1.2 Qualification

The person carrying out the work described here must have completed professional training. The competent person must demonstrably have all of the knowledge, skills and capabilities that are required in order to carry out the work mentioned below.

The following work must only be carried out by competent persons who are sufficiently qualified to do so:

- Set-up
- Dismantling
- Installation
- Start-up
- Inspection and maintenance
- Repair
- Decommissioning
- ▶ Proceed in accordance with current technology.
- ▶ Use the correct tool.

The above-mentioned work must always only be carried out by persons with sufficient qualifications.

This product can be used by children aged from 8 years and persons with reduced physical, sensory or mental capabilities or lack of experience and knowledge if they have been given supervision or instruction concerning use of the product in a safe way and understand the hazards involved. Children must not play with the product. Cleaning and user maintenance work must not be carried out by children unless they are supervised.

1.3 General safety information

The following sections convey important safety information. It is essential to read and observe this information in order to prevent risk of death, risk of injury, material damage or environmental damage.

1.3.1 Gas

If you smell gas:

- ▶ Avoid rooms that smell of gas.
- ▶ If possible, open doors and windows fully and ensure adequate ventilation.



- ▶ Do not use naked flames (e.g. lighters, matches).
- ▶ Do not smoke.
- ▶ Do not use any electrical switches, mains plugs, doorbells, telephones or other communication systems in the building.
- ▶ Close the emergency control valve or the main isolator.
- ▶ If possible, close the gas stopcock on the product.
- ▶ Warn other occupants in the building by yelling or banging on doors or walls.
- ▶ Leave the building immediately and ensure that others do not enter the building.
- ▶ Alert the police and fire brigade, and inform the emergency service department of the gas supply company as soon as you are outside the building.

1.3.2 Liquefied petroleum gas

There is a risk that liquefied petroleum gas may collect in the lower part of multi-configuration air/flue systems at floor level.

If the product is installed below ground level, liquefied petroleum gas may accumulate at floor level if there are any leaks.

To prevent explosions and fire:

- ▶ Do not use liquefied petroleum gas to operate the heat generator for a multi-configuration air/flue system operating at excess pressure.
- ▶ Make sure that liquefied petroleum gas cannot escape from the product or the gas pipe under any circumstances.

To prevent ignition problems when the liquefied petroleum gas tank is poorly ventilated:

- ▶ Ensure that the liquid gas tank has been purged properly before installing the product.
- ▶ If required, contact the filler or the liquid gas supplier.

1.3.3 Flue gas

Flue gases may cause poisoning, while hot flue gases may also cause burns. Flue gases must therefore never be allowed to escape uncontrollably.

What to do if you smell flue gas in the property:

- ▶ Open all accessible doors and windows fully to provide ventilation.
- ▶ Switch off the product.
- ▶ Check the flue gas routes in the product and the flue gas diversions.

To prevent flue gas exit:

- ▶ Only operate the product if the air/flue pipe has been completely installed.
- ▶ With the exception of short periods for testing purposes, only operate the product when the front casing is installed and closed.
- ▶ In order to operate the product, ensure that the condensate siphon is always full.
 - Water seal level for units with condensate siphon (third-party accessory): ≥ 200 mm

To ensure that the seals are not damaged:

- ▶ Instead of grease, use only water or commercially available soft soap to aid installation.

1.3.4 Air supply

Unsuitable or insufficient combustion and room air may lead to material damage, but also to life-threatening situations.

- ▶ Use the data plate, to check the unit types (air/flue gas) for which the product is approved:
 - Unit type B = **open-flued** combustion air supply
 - Unit type C = **room-sealed** combustion air supply
- ▶ If the product has the approval for unit type B **and** you want to operate the product as open-flued, ensure that the air supply to the product's installation room is permanently unobstructed and sufficient in accordance with the relevant ventilation requirements. This also applies, in particular, for cupboard installations.

To prevent corrosion on the product and in the flue system:

- ▶ Ensure that the combustion air supply is free from sprays, solvents, chlorinated cleaning agents, paint, adhesives, ammonia compounds, dust or similar substances.
- ▶ Ensure that no chemical substances are stored at the installation site.



- ▶ If you are installing the product in hairdressing salons, painter's or joiner's workshops, cleaning businesses or similar locations, choose a separate installation room in which the room air is technically free of chemical substances.

1.3.5 Air/flue pipe

The heat generators are system-certified together with the original air/flue pipes.

- ▶ Only use original air/flue pipes from the manufacturer.

1.3.6 Electricity

The power supply terminals L and N remain live.

To prevent electric shocks, proceed as follows before working on the product:

- ▶ Disconnect the product from the power supply by switching off all power supplies at all poles (electrical partition with a contact gap of at least 3 mm, e.g. fuse or circuit breaker) or remove the mains plug (if present).
- ▶ Secure against being switched back on again.
- ▶ Wait at least three minutes until the condensers have discharged.
- ▶ Check that there is no voltage.

1.3.7 Weight

To prevent injuries when transporting the product:

- ▶ Make sure that the product is transported by at least two people.

To prevent material damage to the flexible gas pipe:

- ▶ Never suspend the compact thermal module on the flexible gas pipe.

1.3.8 Explosive and flammable substances

To prevent explosions and fire:

- ▶ Do not use the product in rooms that contain explosive or flammable substances (such as petrol, paper or paint).

1.3.9 High temperatures

High temperatures may occur in the product and its immediate vicinity, and may lead to burns.

To prevent burns:

- ▶ Always ensure that no high temperatures are present, and only work on components once they have cooled down sufficiently.

To prevent material damage that is caused by heat transfer, particularly during soldering work:

- ▶ Before carrying out soldering work, remove all sealing materials.
- ▶ Separate components which may be internally damaged by heat from each other.
- ▶ Only continue the installation processes once all components have cooled down (warm to the touch).

1.3.10 Heating water

Both unsuitable heating water and air in the heating water may cause material damage to the product and in the heat generator circuit.

- ▶ Check the quality of the heating water. (→ Section 9.3)
- ▶ If you use non-diffusion-tight plastic pipes in the heating installation, ensure that no air gets into the heat generator circuit.

1.3.11 Neutralisation device

To prevent contamination of the waste water:

- ▶ Check whether a neutralising unit must be installed in accordance with national regulations.
- ▶ Observe local regulations on neutralising condensate.

1.3.12 Frost

To prevent material damage:

- ▶ Do not install the product in rooms prone to frost.

1.3.13 Safety devices

- ▶ Install the necessary safety devices in the installation.





1.4 Regulations (directives, laws, standards)

- ▶ Observe the national regulations, standards, directives, ordinances and laws.

1.5 List of relevant standards for Great Britain and Ireland

- ▶ Observe the national regulations, standards, directives, ordinances and laws.



You can find a list of relevant standards at:
<https://www.vaillant.co.uk/standards>

Guarantee Registration

Thank you for installing a new Vaillant appliance in your home.

Vaillant appliances are manufactured to the very highest standard so we are pleased to offer our customers a comprehensive guarantee.

To maintain your guarantee, the boiler must be serviced annually by a competent person who holds the required qualifications in accordance with the rules in force of the country where the product is installed and in accordance with the manufacturer's recommendations.

We recommend you complete your guarantee registration as soon as possible.

Sales Support:

Telephone: 0345 602 0262

Technical Enquiries:

Telephone: 0344 693 3133

Email: technical@vaillant.co.uk

General Enquiries:

Telephone: 0345 602 2922

Training Enquiries:

Telephone: 0345 601 8885

Email: training.enquiriesuk@vaillant-group.com

Spares Enquiries:

Telephone: 01773 596 615

To register your Vaillant appliance visit:

<https://self-service.vaillant.co.uk/warranty-registration>



Vaillant is a licensed member of the Benchmark Scheme. Benchmark places responsibilities on both manufacturers and installers. The purpose is to ensure that customers are provided with the correct equipment for their needs, that it is installed, commissioned and serviced in accordance with the manufacturer's instructions by a competent person approved at the time by the Health and Safety Executive and that it meets the requirements of the appropriate Building Regulations. The Benchmark Checklist can be used to demonstrate compliance with Building Regulations and should be provided to the customer for future reference.

Installers are required to carry out installation, commissioning and servicing work in accordance with the Benchmark Code of Practice which is available from the Heating and Hotwater Industry Council who manage and promote the Scheme. Benchmark is managed and promoted by the Heating and Hotwater Industry Council.



3 Technical data

During initial start-up, the operating data may initially deviate from the specified nominal data.

Technical data – General

	VU 10	VU 15	VU 20
Designated country (designation in accordance with ISO 3166)	GB, IE	GB, IE	GB, IE
Permitted gas boiler category (depending on the unit version)	II _{2H3P}	II _{2H3P}	II _{2H3P}
CE PIN	0063CU3910	0063CU3910	0063CU3910
UKCA PIN	0063CU3910	0063CU3910	0063CU3910
Gas connection, boiler side	15 mm	15 mm	15 mm
Flow/return heating connections, boiler side	G 3/4 "	G 3/4 "	G 3/4 "
Flow/return cylinder connections, boiler side	–	–	–
Domestic hot/cold water connections, boiler side	–	–	–
Expansion relief valve connection	15 mm	15 mm	15 mm
Condensate discharge hose connection	19 mm	19 mm	19 mm
Air/flue pipe connection	60/100 mm	60/100 mm	60/100 mm
Capacity of the heating expansion vessel	10 l	10 l	10 l
Pre-charge pressure of the heating expansion vessel	70 kPa (700 mbar)	70 kPa (700 mbar)	70 kPa (700 mbar)
Min. flue gas temperature	35 °C	35 °C	35 °C
Max. flue gas temperature	85 °C	85 °C	85 °C
Approved gas boiler types	C13, C33, C43, C53	C13, C33, C43, C53	C13, C33, C43, C53
NOx class	6	6	6
SAP 2009/2012 annual efficiency (%)	–	–	–
Weight with packaging (incl. accessories)	37 kg	37 kg	37 kg
Weight (without packaging, without water)	34 kg	34 kg	34 kg
Weight ready for operation (filled)	37 kg	37 kg	37 kg

	VU 25	VU 30	VU 35
Designated country (designation in accordance with ISO 3166)	GB, IE	GB, IE	GB, IE
Permitted gas boiler category (depending on the unit version)	II _{2H3P}	II _{2H3P}	I _{2H}
CE PIN	0063CU3910	0063CU3910	0063CU3910
UKCA PIN	0063CU3910	0063CU3910	0063CU3910
Gas connection, boiler side	15 mm	15 mm	15 mm
Flow/return heating connections, boiler side	G 3/4 "	G 3/4 "	G 3/4 "
Flow/return cylinder connections, boiler side	–	–	–
Domestic hot/cold water connections, boiler side	–	–	–
Expansion relief valve connection	15 mm	15 mm	15 mm
Condensate discharge hose connection	19 mm	19 mm	19 mm
Air/flue pipe connection	60/100 mm	60/100 mm	60/100 mm
Capacity of the heating expansion vessel	10 l	10 l	10 l
Pre-charge pressure of the heating expansion vessel	70 kPa (700 mbar)	70 kPa (700 mbar)	70 kPa (700 mbar)
Min. flue gas temperature	35 °C	35 °C	35 °C
Max. flue gas temperature	85 °C	85 °C	85 °C
Approved gas boiler types	C13, C33, C43, C53	C13, C33, C43, C53	C13, C33, C43, C53
NOx class	6	6	6
SAP 2009/2012 annual efficiency (%)	–	–	–
Weight with packaging (incl. accessories)	39 kg	39 kg	41 kg

	VU 25	VU 30	VU 35
Weight (without packaging, without water)	36 kg	36 kg	40.5 kg
Weight ready for operation (filled)	41 kg	41 kg	44 kg

	VUW 20/26	VUW 25/32	VUW 30/36
Designated country (designation in accordance with ISO 3166)	GB, IE	GB, IE	GB, IE
Permitted gas boiler category (depending on the unit version)	II _{2H3P}	II _{2H3P}	II _{2H3P}
CE PIN	0063CU3910	0063CU3910	0063CU3910
UKCA PIN	0063CU3910	0063CU3910	0063CU3910
Gas connection, boiler side	15 mm	15 mm	15 mm
Flow/return heating connections, boiler side	G 3/4 "	G 3/4 "	G 3/4 "
Flow/return cylinder connections, boiler side	–	–	–
Domestic hot/cold water connections, boiler side	G 3/4 "	G 3/4 "	G 3/4 "
Expansion relief valve connection	15 mm	15 mm	15 mm
Condensate discharge hose connection	19 mm	19 mm	19 mm
Air/flue pipe connection	60/100 mm	60/100 mm	60/100 mm
Capacity of the heating expansion vessel	10 l	10 l	10 l
Pre-charge pressure of the heating expansion vessel	70 kPa (700 mbar)	70 kPa (700 mbar)	70 kPa (700 mbar)
Min. flue gas temperature	35 °C	35 °C	35 °C
Max. flue gas temperature	85 °C	85 °C	85 °C
Approved gas boiler types	C13, C33, C43, C53	C13, C33, C43, C53	C13, C33, C43, C53
NOx class	6	6	6
SAP 2009/2012 annual efficiency (%)	–	–	–
Weight with packaging (incl. accessories)	39 kg	41 kg	41 kg
Weight (without packaging, without water)	36 kg	37 kg	37 kg
Weight ready for operation (filled)	40 kg	43 kg	43 kg

	VUW 30/40
Designated country (designation in accordance with ISO 3166)	GB, IE
Permitted gas boiler category (depending on the unit version)	I _{2H}
CE PIN	0063CU3910
UKCA PIN	0063CU3910
Gas connection, boiler side	15 mm
Flow/return heating connections, boiler side	G 3/4 "
Flow/return cylinder connections, boiler side	–
Domestic hot/cold water connections, boiler side	G 3/4 "
Expansion relief valve connection	15 mm
Condensate discharge hose connection	19 mm
Air/flue pipe connection	60/100 mm
Capacity of the heating expansion vessel	10 l
Pre-charge pressure of the heating expansion vessel	70 kPa (700 mbar)
Min. flue gas temperature	35 °C
Max. flue gas temperature	85 °C
Approved gas boiler types	C13, C33, C43, C53
NOx class	6
SAP 2009/2012 annual efficiency (%)	–
Weight with packaging (incl. accessories)	44 kg

	VUW 30/40
Weight (without packaging, without water)	41 kg
Weight ready for operation (filled)	48 kg

Technical data – G20 output/heat input (depending on the unit version)

	VU 10	VU 15	VU 20
Gas connection pressure, G20 natural gas	2.0 kPa (20.0 mbar)	2.0 kPa (20.0 mbar)	2.0 kPa (20.0 mbar)
NOx emission, weighted, G20 (EN 15502-2-1)	35.70 mg/kW·h	35.00 mg/kW·h	33.20 mg/kW·h
30% efficiency, G20	108.2 %	108.5 %	108.8 %
Gas flow rate for max. gas volume at 15 °C and 1013 mbar, G20	2.16 m³/h	2.16 m³/h	2.59 m³/h
Nominal heat output range at 40/30 °C	2.9 to 10.9 kW	2.9 to 16.4 kW	2.9 to 21.7 kW
Nominal heat output range at 50/30 °C	2.8 to 10.6 kW	2.8 to 15.9 kW	2.8 to 21.2 kW
Nominal heat output range at 60/40 °C	2.6 to 10.1 kW	2.6 to 15.1 kW	2.6 to 20.3 kW
Nominal heat output range at 80/60 °C	2.5 to 9.9 kW	2.5 to 14.8 kW	2.5 to 19.8 kW
Max. heat input for heating	10.2 kW	15.3 kW	20.4 kW
Heating min. heat input	2.7 kW	2.7 kW	2.7 kW
Min. flue gas mass flow rate	1.23 g/s (4.43 kg/h)	1.23 g/s (4.43 kg/h)	1.23 g/s (4.43 kg/h)
Max. flue gas mass flow rate	10.28 g/s (37.01 kg/h)	10.28 g/s (37.01 kg/h)	12.34 g/s (44.42 kg/h)
Max. DHW heat output	19.6 kW	19.6 kW	23.6 kW
DHW nominal heat input	20.4 kW	20.4 kW	24.5 kW
Nominal heat input range for heating	2.7 to 10.2 kW	2.7 to 15.3 kW	2.7 to 20.4 kW
Heating adjustment range	10.2 kW (auto)	2.7 to 15.3 kW	2.7 to 20.4 kW

	VU 25	VU 30	VU 35
Gas connection pressure, G20 natural gas	2.0 kPa (20.0 mbar)	2.0 kPa (20.0 mbar)	2.0 kPa (20.0 mbar)
NOx emission, weighted, G20 (EN 15502-2-1)	27.00 mg/kW·h	27.80 mg/kW·h	27.30 mg/kW·h
30% efficiency, G20	109.4 %	109.1 %	109.4 %
Gas flow rate for max. gas volume at 15 °C and 1013 mbar, G20	3.24 m³/h	3.76 m³/h	4.32 m³/h
Nominal heat output range at 40/30 °C	4.0 to 26.9 kW	4.3 to 32.9 kW	5.2 to 37.8 kW
Nominal heat output range at 50/30 °C	3.9 to 26.5 kW	4.2 to 32.2 kW	5.0 to 37.7 kW
Nominal heat output range at 60/40 °C	3.6 to 25.6 kW	4.0 to 31.1 kW	4.8 to 36.4 kW
Nominal heat output range at 80/60 °C	3.5 to 24.9 kW	3.7 to 29.9 kW	4.5 to 34.9 kW
Max. heat input for heating	25.5 kW	30.6 kW	35.7 kW
Heating min. heat input	3.7 kW	4.2 kW	4.8 kW
Min. flue gas mass flow rate	1.71 g/s (6.16 kg/h)	1.94 g/s (6.98 kg/h)	2.22 g/s (7.99 kg/h)
Max. flue gas mass flow rate	14.68 g/s (52.85 kg/h)	17.52 g/s (63.07 kg/h)	20.55 g/s (73.98 kg/h)
Max. DHW heat output	29.6 kW	34.3 kW	39.4 kW
DHW nominal heat input	30.6 kW	35.5 kW	40.8 kW
Nominal heat input range for heating	3.7 to 25.5 kW	4.2 to 30.6 kW	4.8 to 35.7 kW
Heating adjustment range	3.7 to 25.5 kW	4.2 to 30.6 kW	4.8 to 35.7 kW

	VUW 20/26	VUW 25/32	VUW 30/36
Gas connection pressure, G20 natural gas	2.0 kPa (20.0 mbar)	2.0 kPa (20.0 mbar)	2.0 kPa (20.0 mbar)
NOx emission, weighted, G20 (EN 15502-2-1)	33.20 mg/kW·h	27.00 mg/kW·h	27.80 mg/kW·h
30% efficiency, G20	108.8 %	109.4 %	109.1 %

	VUW 20/26	VUW 25/32	VUW 30/36
Gas flow rate for max. gas volume at 15 °C and 1013 mbar, G20	2.80 m³/h	3.45 m³/h	3.88 m³/h
Nominal heat output range at 40/30 °C	2.9 to 21.7 kW	4.0 to 26.9 kW	4.3 to 32.9 kW
Nominal heat output range at 50/30 °C	2.8 to 21.2 kW	3.9 to 26.5 kW	4.2 to 32.2 kW
Nominal heat output range at 60/40 °C	2.6 to 20.3 kW	3.6 to 25.6 kW	4.0 to 31.1 kW
Nominal heat output range at 80/60 °C	2.5 to 19.8 kW	3.5 to 24.9 kW	3.7 to 29.9 kW
Max. heat input for heating	20.4 kW	25.5 kW	30.6 kW
Heating min. heat input	2.7 kW	3.7 kW	4.2 kW
Min. flue gas mass flow rate	1.23 g/s (4.43 kg/h)	1.71 g/s (6.16 kg/h)	1.94 g/s (6.98 kg/h)
Max. flue gas mass flow rate	13.26 g/s (47.74 kg/h)	15.75 g/s (56.70 kg/h)	18.36 g/s (66.10 kg/h)
Max. DHW heat output	–	–	–
DHW nominal heat input	26.5 kW	32.6 kW	36.7 kW
Nominal heat input range for heating	2.7 to 20.4 kW	3.7 to 25.5 kW	4.2 to 30.6 kW
Heating adjustment range	2.7 to 20.4 kW	3.7 to 25.5 kW	4.2 to 30.6 kW

	VUW 30/40
Gas connection pressure, G20 natural gas	2.0 kPa (20.0 mbar)
NOx emission, weighted, G20 (EN 15502-2-1)	26.30 mg/kW-h
30% efficiency, G20	109.2 %
Gas flow rate for max. gas volume at 15 °C and 1013 mbar, G20	4.32 m³/h
Nominal heat output range at 40/30 °C	5.2 to 32.9 kW
Nominal heat output range at 50/30 °C	5.0 to 32.3 kW
Nominal heat output range at 60/40 °C	4.8 to 31.2 kW
Nominal heat output range at 80/60 °C	4.5 to 29.8 kW
Max. heat input for heating	30.6 kW
Heating min. heat input	4.8 kW
Min. flue gas mass flow rate	2.22 g/s (7.99 kg/h)
Max. flue gas mass flow rate	20.55 g/s (73.98 kg/h)
Max. DHW heat output	–
DHW nominal heat input	40.8 kW
Nominal heat input range for heating	4.8 to 30.6 kW
Heating adjustment range	4.8 to 30.6 kW

Technical data – G31 output/heat input (depending on the unit version)

	VU 10	VU 15	VU 20
Gas connection pressure, G31 liquefied petroleum gas	3.7 kPa (37.0 mbar)	3.7 kPa (37.0 mbar)	3.7 kPa (37.0 mbar)
NOx emission, weighted, G31 (EN 15502-2-1)	35.46 mg/kW-h	28.04 mg/kW-h	38.75 mg/kW-h
Gas flow rate for max. gas volume at 15 °C and 1013 mbar, G31	0.83 m³/h	0.83 m³/h	1.0 m³/h
Nominal heat output range at 40/30 °C	5.5 to 10.7 kW	5.5 to 16.1 kW	5.5 to 21.2 kW
Nominal heat output range at 50/30 °C	5.4 to 10.3 kW	5.4 to 15.4 kW	5.4 to 20.6 kW
Nominal heat output range at 60/40 °C	5.1 to 9.9 kW	5.1 to 14.8 kW	5.1 to 20.0 kW
Nominal heat output range at 80/60 °C	5.0 to 9.9 kW	5.0 to 14.8 kW	5.0 to 19.8 kW
Max. heat input for heating	10.2 kW	15.3 kW	20.4 kW
Heating min. heat input	5.2 kW	5.2 kW	5.2 kW
Min. flue gas mass flow rate	2.53 g/s (9.11 kg/h)	2.53 g/s (9.11 kg/h)	2.53 g/s (9.11 kg/h)

	VU 10	VU 15	VU 20
Max. flue gas mass flow rate	9.78 g/s (35.21 kg/h)	9.78 g/s (35.21 kg/h)	11.99 g/s (43.16 kg/h)
Max. DHW heat output	19.5 kW	19.5 kW	23.3 kW
DHW nominal heat input	20.4 kW	20.4 kW	24.5 kW
Nominal heat input range for heating	5.2 to 10.2 kW	5.2 to 15.3 kW	5.2 to 20.4 kW
Heating adjustment range	10.2 kW (auto)	5.2 to 15.3 kW	5.2 to 20.4 kW

	VU 25	VU 30	VUW 20/26
Gas connection pressure, G31 liquefied petroleum gas	3.7 kPa (37.0 mbar)	3.7 kPa (37.0 mbar)	3.7 kPa (37.0 mbar)
NOx emission, weighted, G31 (EN 15502-2-1)	25.44 mg/kW·h	25.33 mg/kW·h	38.75 mg/kW·h
Gas flow rate for max. gas volume at 15 °C and 1013 mbar, G31	1.25 m³/h	1.45 m³/h	1.07 m³/h
Nominal heat output range at 40/30 °C	8.6 to 26.7 kW	8.6 to 31.8 kW	5.5 to 21.2 kW
Nominal heat output range at 50/30 °C	8.2 to 26.2 kW	8.2 to 31.3 kW	5.4 to 20.6 kW
Nominal heat output range at 60/40 °C	8.0 to 25.2 kW	8.0 to 30.3 kW	5.1 to 20.0 kW
Nominal heat output range at 80/60 °C	8.0 to 24.6 kW	8.0 to 29.5 kW	5.0 to 19.8 kW
Max. heat input for heating	25.5 kW	30.6 kW	20.4 kW
Heating min. heat input	8.2 kW	8.2 kW	5.2 kW
Min. flue gas mass flow rate	4.10 g/s (14.76 kg/h)	4.10 g/s (14.76 kg/h)	2.53 g/s (9.11 kg/h)
Max. flue gas mass flow rate	15.08 g/s (54.29 kg/h)	17.85 g/s (64.26 kg/h)	12.82 g/s (46.15 kg/h)
Max. DHW heat output	29.5 kW	34.2 kW	–
DHW nominal heat input	30.6 kW	35.5 kW	26.2 kW
Nominal heat input range for heating	8.2 to 25.5 kW	8.2 to 30.6 kW	5.2 to 20.4 kW
Heating adjustment range	8.2 to 25.5 kW	8.2 to 30.6 kW	5.2 to 20.4 kW

	VUW 25/32	VUW 30/36
Gas connection pressure, G31 liquefied petroleum gas	3.7 kPa (37.0 mbar)	3.7 kPa (37.0 mbar)
NOx emission, weighted, G31 (EN 15502-2-1)	25.44 mg/kW·h	25.33 mg/kW·h
Gas flow rate for max. gas volume at 15 °C and 1013 mbar, G31	1.33 m³/h	1.45 m³/h
Nominal heat output range at 40/30 °C	8.6 to 26.7 kW	8.6 to 31.8 kW
Nominal heat output range at 50/30 °C	8.2 to 26.2 kW	8.2 to 31.3 kW
Nominal heat output range at 60/40 °C	8.0 to 25.2 kW	8.0 to 30.3 kW
Nominal heat output range at 80/60 °C	8.0 to 24.6 kW	8.0 to 29.5 kW
Max. heat input for heating	25.5 kW	30.6 kW
Heating min. heat input	8.2 kW	8.2 kW
Min. flue gas mass flow rate	4.10 g/s (14.76 kg/h)	4.10 g/s (14.76 kg/h)
Max. flue gas mass flow rate	16.06 g/s (57.82 kg/h)	17.85 g/s (64.26 kg/h)
Max. DHW heat output	–	–
DHW nominal heat input	32.6 kW	35.5 kW
Nominal heat input range for heating	8.2 to 25.5 kW	8.2 to 30.6 kW
Heating adjustment range	8.2 to 25.5 kW	8.2 to 30.6 kW

Technical data – Heating

	VU 10	VU 15	VU 20
Max. flow temperature	85 °C	85 °C	85 °C
Flow temperature adjustment range (factory setting: 75 °C)	30 to 80 °C	30 to 80 °C	30 to 80 °C

	VU 10	VU 15	VU 20
Permissible operating pressure, heating	0.25 MPa (2.50 bar)	0.25 MPa (2.50 bar)	0.25 MPa (2.50 bar)
Nominal circulation water volume based on $\Delta T = 20$ K, 80/60 °C	439 l/h	659 l/h	878 l/h
Approx. condensate rate (pH value 3.5 to 4.0) in 50/30 °C heating mode	1.0 l/h	1.5 l/h	2.0 l/h
Remaining pump head at nominal circulation water volume	0.025 MPa (0.250 bar)	0.025 MPa (0.250 bar)	0.025 MPa (0.250 bar)

	VU 25	VU 30	VU 35
Max. flow temperature	85 °C	85 °C	85 °C
Flow temperature adjustment range (factory setting: 75 °C)	30 to 80 °C	30 to 80 °C	30 to 80 °C
Permissible operating pressure, heating	0.25 MPa (2.50 bar)	0.25 MPa (2.50 bar)	0.25 MPa (2.50 bar)
Nominal circulation water volume based on $\Delta T = 20$ K, 80/60 °C	1,098 l/h	1,318 l/h	1,537 l/h
Approx. condensate rate (pH value 3.5 to 4.0) in 50/30 °C heating mode	2.6 l/h	3.1 l/h	3.6 l/h
Remaining pump head at nominal circulation water volume	0.025 MPa (0.250 bar)	0.025 MPa (0.250 bar)	0.025 MPa (0.250 bar)

	VUW 20/26	VUW 25/32	VUW 30/36
Max. flow temperature	85 °C	85 °C	85 °C
Flow temperature adjustment range (factory setting: 75 °C)	30 to 80 °C	30 to 80 °C	30 to 80 °C
Permissible operating pressure, heating	0.25 MPa (2.50 bar)	0.25 MPa (2.50 bar)	0.25 MPa (2.50 bar)
Nominal circulation water volume based on $\Delta T = 20$ K, 80/60 °C	878 l/h	1,098 l/h	1,318 l/h
Approx. condensate rate (pH value 3.5 to 4.0) in 50/30 °C heating mode	2.0 l/h	2.6 l/h	3.1 l/h
Remaining pump head at nominal circulation water volume	0.025 MPa (0.250 bar)	0.025 MPa (0.250 bar)	0.025 MPa (0.250 bar)

	VUW 30/40
Max. flow temperature	85 °C
Flow temperature adjustment range (factory setting: 75 °C)	30 to 80 °C
Permissible operating pressure, heating	0.25 MPa (2.50 bar)
Nominal circulation water volume based on $\Delta T = 20$ K, 80/60 °C	1,318 l/h
Approx. condensate rate (pH value 3.5 to 4.0) in 50/30 °C heating mode	3.1 l/h
Remaining pump head at nominal circulation water volume	0.025 MPa (0.250 bar)

Technical data – Domestic hot water

	VUW 20/26	VUW 25/32	VUW 30/36
Start-up flow rate	2.0 l/min	2.0 l/min	2.0 l/min
Specific flow rate D ($\Delta T = 30$ K) (EN 13203-1)	12.4 l/min	15.2 l/min	17.0 l/min
Flow rate ($\Delta T = 35$ K)	10.6 l/min	13.0 l/min	14.6 l/min
Permissible operating pressure	0.95 MPa (9.50 bar)	0.95 MPa (9.50 bar)	0.95 MPa (9.50 bar)
Required connection pressure	0.07 MPa (0.70 bar)	0.07 MPa (0.70 bar)	0.07 MPa (0.70 bar)
Domestic hot water temperature adjustment range	35 to 65 °C	35 to 65 °C	35 to 65 °C
Flow rate limiter	8.7 l/min	10.4 l/min	11.7 l/min
Classification in accordance with the total comfort factor (EN 13203-1)	***	***	***

	VUW 30/40
Start-up flow rate	2.0 l/min
Specific flow rate D ($\Delta T = 30 \text{ K}$) (EN 13203-1)	19.0 l/min
Flow rate ($\Delta T = 35 \text{ K}$)	16.3 l/min
Permissible operating pressure	0.95 MPa (9.50 bar)
Required connection pressure	0.07 MPa (0.70 bar)
Domestic hot water temperature adjustment range	35 to 65 °C
Flow rate limiter	14.0 l/min
Classification in accordance with the total comfort factor (EN 13203-1)	* * *

Technical data – Electrics

	VU 10	VU 15	VU 20
Nominal voltage/mains frequency	230 V/50 Hz	230 V/50 Hz	230 V/50 Hz
Permissible connected voltage	190 to 253 V	190 to 253 V	190 to 253 V
Built-in fuse (slow-blow)	4 A	4 A	4 A
Max. power consumption in heating mode	55 W	66.3 W	81.7 W
Max. power consumption in domestic hot water mode	96 W	96 W	102 W
Electrical standby energy consumption	< 2 W	< 2 W	< 2 W
IP rating	IP X5 D	IP X5 D	IP X5 D

	VU 25	VU 30	VU 35
Nominal voltage/mains frequency	230 V/50 Hz	230 V/50 Hz	230 V/50 Hz
Permissible connected voltage	190 to 253 V	190 to 253 V	190 to 253 V
Built-in fuse (slow-blow)	4 A	4 A	4 A
Max. power consumption in heating mode	87.6 W	95.4 W	110.4 W
Max. power consumption in domestic hot water mode	102 W	108 W	134 W
Electrical standby energy consumption	< 2 W	< 2 W	< 2 W
IP rating	IP X5 D	IP X5 D	IP X5 D

	VUW 20/26	VUW 25/32	VUW 30/36
Nominal voltage/mains frequency	230 V/50 Hz	230 V/50 Hz	230 V/50 Hz
Permissible connected voltage	190 to 253 V	190 to 253 V	190 to 253 V
Built-in fuse (slow-blow)	4 A	4 A	4 A
Max. power consumption in heating mode	81.7 W	87.6 W	95.4 W
Max. power consumption in domestic hot water mode	112 W	91 W	106 W
Electrical standby energy consumption	< 2 W	< 2 W	< 2 W
IP rating	IP X5 D	IP X5 D	IP X5 D

	VUW 30/40
Nominal voltage/mains frequency	230 V/50 Hz
Permissible connected voltage	190 to 253 V
Built-in fuse (slow-blow)	4 A
Max. power consumption in heating mode	98.5 W
Max. power consumption in domestic hot water mode	134 W
Electrical standby energy consumption	< 2 W
IP rating	IP X5 D

4 Notes on the documentation

- ▶ Always observe all the operating and installation instructions included with the system components.
- ▶ Pass these instructions and all other applicable documents on to the end user.

These instructions apply for the following products only:

Product article number

VU 10CS/1-5 (N-GB) ecoTEC plus 610	0010036009
VU 15CS/1-5 (N-GB) ecoTEC plus 615	0010036010
VU 20CS/1-5 (N-GB) ecoTEC plus 620	0010036011
VU 25CS/1-5 (N-GB) ecoTEC plus 625	0010036012
VU 30CS/1-5 (N-GB) ecoTEC plus 630	0010036013
VU 35CS/1-5 (N-GB) ecoTEC plus 635	0010036014
VUW 20/26CS/1-5 (N-GB) ecoTEC plus 826	0010036015
VUW 25/32CS/1-5 (N-GB) ecoTEC plus 832	0010036016
VUW 30/36CS/1-5 (N-GB) ecoTEC plus 836	0010036017
VUW 30/40CS/1-5 (N-GB) ecoTEC plus 840	0010036018

Gas Council Numbers

VU 10CS/1-5 (N-GB) ecoTEC plus 610	41-694-45
VU 15CS/1-5 (N-GB) ecoTEC plus 615	41-694-46
VU 20CS/1-5 (N-GB) ecoTEC plus 620	41-694-47
VU 25CS/1-5 (N-GB) ecoTEC plus 625	41-694-48
VU 30CS/1-5 (N-GB) ecoTEC plus 630	41-694-49
VU 35CS/1-5 (N-GB) ecoTEC plus 635	41-694-50
VUW 20/26CS/1-5 (N-GB) ecoTEC plus 826	47-044-92
VUW 25/32CS/1-5 (N-GB) ecoTEC plus 832	47-044-93
VUW 30/36CS/1-5 (N-GB) ecoTEC plus 836	47-044-94
VUW 30/40CS/1-5 (N-GB) ecoTEC plus 840	47-044-95

The following products can be converted to liquefied petroleum gas operation:

Product article number

VU 10CS/1-5 (N-GB) ecoTEC plus 610	0010036009
VU 15CS/1-5 (N-GB) ecoTEC plus 615	0010036010
VU 20CS/1-5 (N-GB) ecoTEC plus 620	0010036011
VU 25CS/1-5 (N-GB) ecoTEC plus 625	0010036012
VU 30CS/1-5 (N-GB) ecoTEC plus 630	0010036013
VUW 20/26CS/1-5 (N-GB) ecoTEC plus 826	0010036015
VUW 25/32CS/1-5 (N-GB) ecoTEC plus 832	0010036016
VUW 30/36CS/1-5 (N-GB) ecoTEC plus 836	0010036017

These instructions apply only to:

- Great Britain
- Ireland

5 Product description

5.1 CE marking



The CE marking shows that the products comply with the basic requirements of the applicable directives as stated on the declaration of conformity.

The declaration of conformity can be viewed at the manufacturer's site.

5.2 UKCA mark



The UKCA marking shows that the products comply with the basic requirements of the applicable directives as stated on the declaration of conformity.

The declaration of conformity can be viewed at the manufacturer's site.

5.3 Hot Water Association

Vaillant is a full member of the Hot Water Association and promotes the scheme in association with its cylinder range. Details are available on the web site www.vaillant.co.uk



5.4 Water Regulations Advisory Scheme

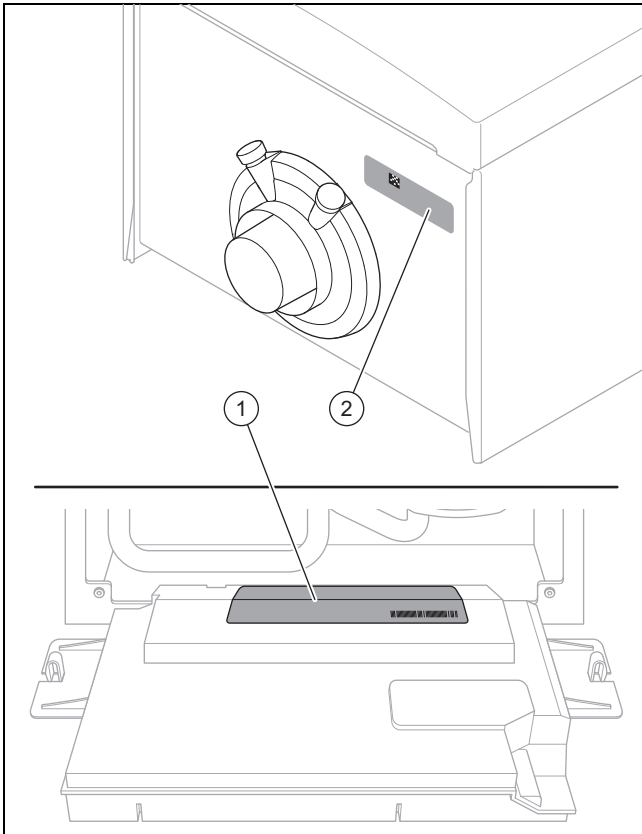

The product meets the requirements of this quality standard.

5.5 Data plate



Two data plates are attached to the product at the factory. The data plate on the top of the unit (2) is always accessible and contains the basic information for the chimney sweep. The main data plate (1) with all of the information is attached to the rear of the electronics box. Any information that is not listed here can be found in separate sections.

Information	Meaning
	Read the instructions.
E.g. VC, VU, VM, VHR S	Product without integrated domestic hot water generation (boiler)
E.g. VCW, VUW, VMW, VHR	Product with integrated domestic hot water generation (combi boiler)
10 - 43	Nominal heat output
C	Condensing boiler
S	Stainless steel heat exchanger
F	ExtraCondense, stainless steel heat exchanger
/1	Product generation
-5	Product equipment
E.g. N, E	Gas group
E.g. AT, BE, CH, DE, DK, ES, FR, IT, NL, NO, PL, SE	Designated country
ecoTEC plus	Marketing name
E.g. I2N, 2N, I2EL-wLs, I2H, G20/G27 – 20 mbar (2.0 kPa) E.g. I3P, G31 – 37 mbar (3.7 kPa)	Gas group and gas connection pressure as set at the factory
Kat.	Gas boiler category
Type	Unit types

Information	Meaning
PMS	Permissible operating pressure, heating mode
Pnw (For boiler only)	Maximum output power
PMW (For combi boiler only)	Permissible operating pressure for domestic hot water mode
D (For combi boiler only)	Specific domestic hot water flow rate value
DSN	Device specific number
NOx-class	NOx class (nitrogen oxide emissions)
T _{max}	Maximum flow temperature
V	Mains voltage
Hz	Mains frequency
W	Maximum electrical power consumption
IP	IP rating
	Heating mode
	DHW mode
P _n	Nominal heat output range (80/60 °C)
P _{nc}	Condensing nominal heat output range (50/30 °C)
Q _n	Heat input range
Q _{nw}	Heat input range for domestic hot water generation
	Barcode with serial number 3rd to 6th digits = production date (year/week) 7th to 16th digit = product article number

5.6 Serial number

The serial numbers are located on the underside of the front panel and on the data plate.

5.7 Sitherm Pro™ technology

The intelligent combustion regulation is based on the adaptive Siemens Sitherm Pro™ combustion optimisation.

5.8 Display of the energy consumption, energy yields and efficiencies



Note

When replacing the PCB, the values recorded up to that point are completely reset in the product and system control.

The product, the system control and the app show approximate values for energy consumption, energy yields and efficiencies, which are extrapolated based on calculation algorithms.

The values that are displayed in the app may differ from the other display options due to staggered transfer intervals.

The determined values depend on:

- Installation and system of the heating installation
- User behaviour

- Seasonal weather effects
- Various tolerances of unit-internal components

The values can be read in the following time forms:

- Today
- Yesterday
- Last month
- Last year
- Total

The recording of the values only includes the product in the factory-delivered condition. Supplementary accessories, even if they are installed on the product, as well as any other components in the heating system and other external consumers, are not part of the data recording.

Deviations between the determined values and the actual values may be significant. The determined values are therefore not suitable for creating or comparing energy billing, for example.

5.9 Product design

Validity: VU 10CS/1-5 (N-GB) ecoTEC plus 610 OR VU 15CS/1-5 (N-GB) ecoTEC plus 615 OR VU 20CS/1-5 (N-GB) ecoTEC plus 620 OR VU 25CS/1-5 (N-GB) ecoTEC plus 625 OR VU 30CS/1-5 (N-GB) ecoTEC plus 630 OR VU 35CS/1-5 (N-GB) ecoTEC plus 635

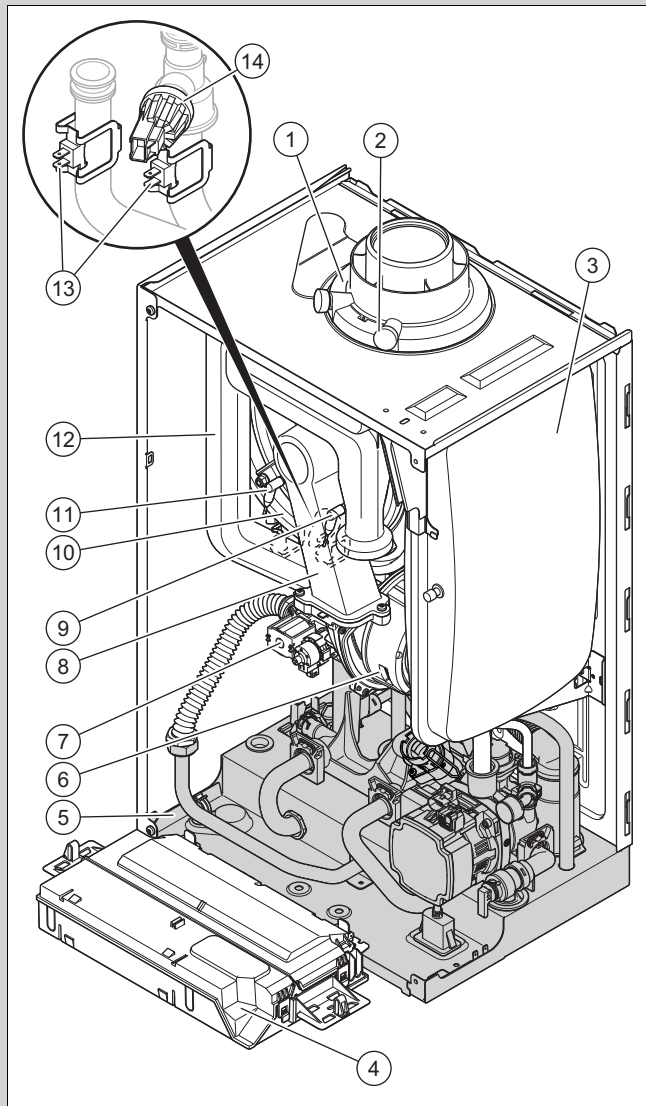

- | | | | |
|---|----------------------------------|---|-------------------------|
| 1 | Connection for the air/flue pipe | 2 | Flue gas analysis point |
| | | 3 | Expansion vessel |

- | | | | |
|---|------------------------|----|-----------------------|
| 4 | Electronics box | 9 | Control electrode |
| 5 | Hydraulic block | 10 | Heat exchanger |
| 6 | Fan | 11 | Ignition electrode |
| 7 | Gas valve assembly | 12 | Air intake pipe |
| 8 | Compact thermal module | 13 | Temperature sensor |
| | | 14 | Water pressure sensor |

Validity: VUW 20/26CS/1-5 (N-GB) ecoTEC plus 826 OR VUW 25/32CS/1-5 (N-GB) ecoTEC plus 832 OR VUW 30/36CS/1-5 (N-GB) ecoTEC plus 836 OR VUW 30/40CS/1-5 (N-GB) ecoTEC plus 840

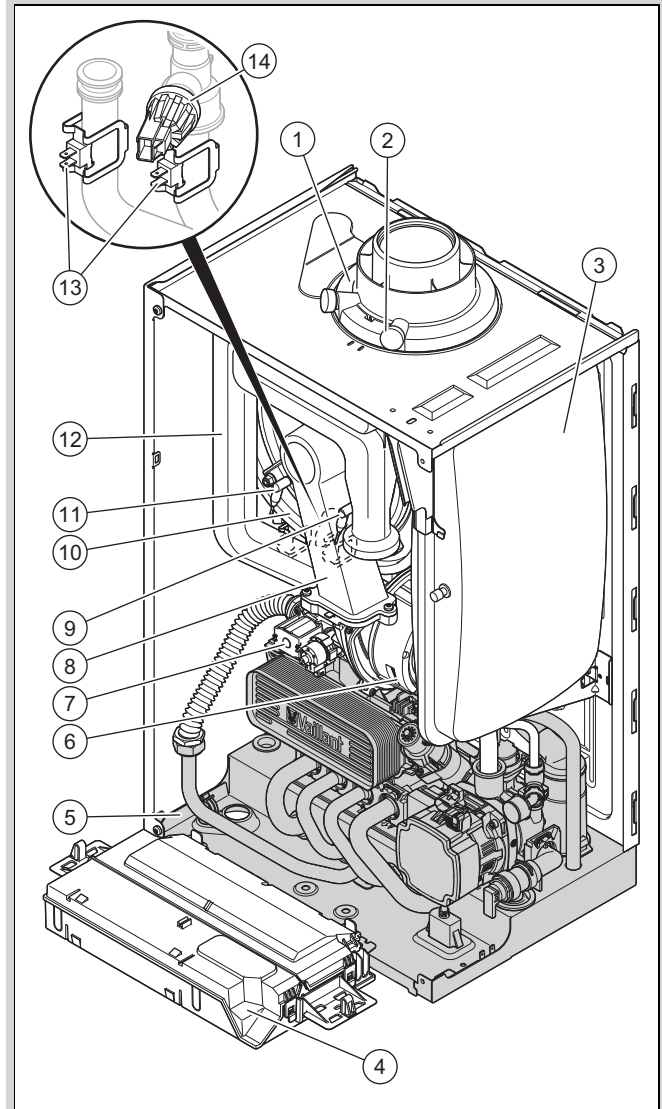

- | | | | |
|---|----------------------------------|----|------------------------|
| 1 | Connection for the air/flue pipe | 8 | Compact thermal module |
| 2 | Flue gas analysis point | 9 | Control electrode |
| 3 | Expansion vessel | 10 | Heat exchanger |
| 4 | Electronics box | 11 | Ignition electrode |
| 5 | Hydraulic block | 12 | Air intake pipe |
| 6 | Fan | 13 | Temperature sensor |
| 7 | Gas valve assembly | 14 | Water pressure sensor |

5.10 Design of the product's hydraulic block

Validity: VU 10CS/1-5 (N-GB) ecoTEC plus 610 OR VU 15CS/1-5 (N-GB) ecoTEC plus 615 OR VU 20CS/1-5 (N-GB) ecoTEC plus 620 OR VU 25CS/1-5 (N-GB) ecoTEC plus 625 OR VU 30CS/1-5 (N-GB) ecoTEC plus 630 OR VU 35CS/1-5 (N-GB) ecoTEC plus 635

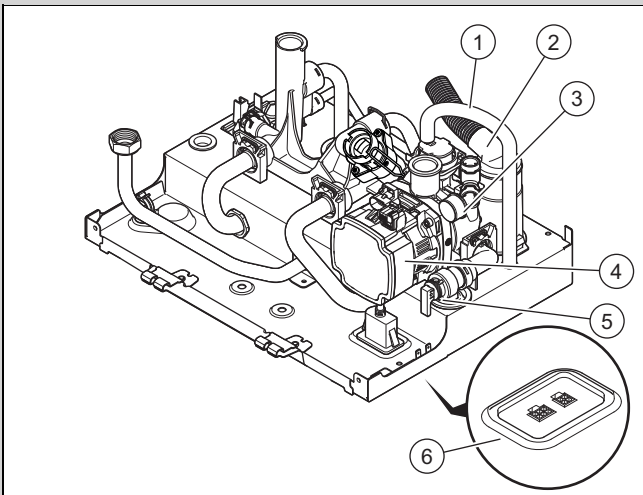

- | | | | |
|---|----------------------|---|-------------------------------|
| 1 | Purging hose | 4 | High-efficiency pump |
| 2 | Condensate discharge | 5 | Expansion relief valve |
| 3 | Manometer | 6 | Connectivity Interface Module |

Validity: VUW 20/26CS/1-5 (N-GB) ecoTEC plus 826 OR VUW 25/32CS/1-5 (N-GB) ecoTEC plus 832 OR VUW 30/36CS/1-5 (N-GB) ecoTEC plus 836 OR VUW 30/40CS/1-5 (N-GB) ecoTEC plus 840

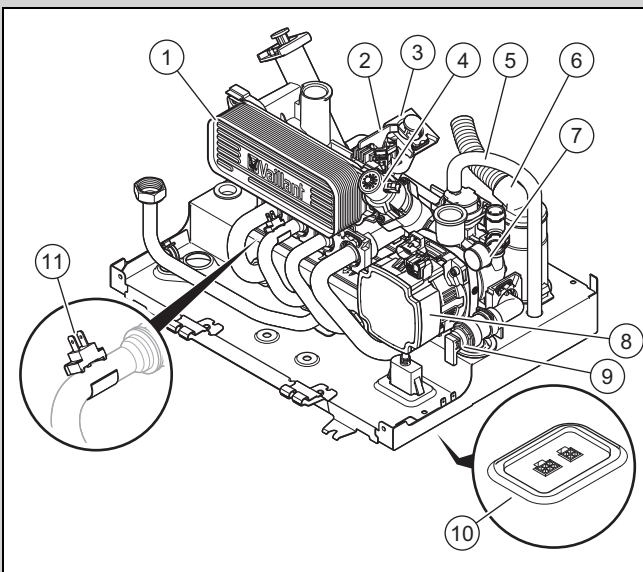

- | | | | |
|---|-----------------------------|----|-------------------------------|
| 1 | Secondary heat exchanger | 6 | Condensate discharge |
| 2 | Impeller water flow sensor | 7 | Manometer |
| 3 | Flow rate limiter | 8 | High-efficiency pump |
| 4 | Prioritising diverter valve | 9 | Expansion relief valve |
| 5 | Purging hose | 10 | Connectivity Interface Module |
| | | 11 | Outlet temperature sensor |

5.11 Safety Devices

5.11.1 Electrical Supply Failure

The boiler will not work without an electrical supply. Normal operation of the boiler should resume when the electrical supply is restored.

Reset any external controls, to resume normal operation of the central heating.

If the boiler does not resume normal operation press the reset button. If the boiler does not resume normal operation after this call your Installation/ Servicing company or Vaillant service.

5.11.2 Overheating Safety

The boiler software is designed to recognise the potential for an overheat lockout and will shutdown before this happens. To restart the boiler, press the reset button on the boiler interface.

If the boiler fails to resume normal operation and all external controls are calling for heat, then call your Installation/ Servicing company or Vaillant service.

5.11.3 Frost protection

The appliance has a built in frost protection device that protects the boiler from freezing. With the gas and electric supplies ON and irrespective of any room thermostat setting, the frost protection device will operate the pump when the temperature of the boiler water falls below 12 °C.

A timer is used so that the temperature can be checked periodically. After 10 minutes the pump will be stopped if the temperature is higher than 15 °C or has already reached 35 °C. The burner will activate if the boiler temperature does not reach 15 °C after 30 minutes or at any time if the temperature drops to 5 °C.

The burner will switch off when the temperature reaches 35 °C.

5.11.4 Condensate Drain Blockage

As a safety feature the boiler will stop working if the condensate drain becomes blocked. During freezing conditions this may be due to the forming of ice in the condensate drain external to the house. Release an ice blockage by the use of warm cloths on the pipe. After pressing reset the boiler should restart.

6 Set-up

6.1 Checking the scope of delivery

- Check that the scope of delivery is complete and intact.

Validity: Product with connected domestic hot water cylinder

Quantity	Designation
1	Condensing boiler
1	Bag with unit mounting bracket and fixing material
1	Bag with drain pipe and screwed connection for the expansion relief valve
1	Gas isolation valve
1	Gas connection pipe, 15 mm diameter

Quantity	Designation
2	Heating flow and return connection pipe, 20 mm diameter
2	Service valve
2	Bag with small parts
1	Condensate discharge hose
1	Mounting template
1	Enclosed documentation

Validity: Product with integrated hot water generation

Quantity	Designation
1	Condensing boiler
1	Bag with unit mounting bracket and fixing material
1	Bag with drain pipe and screwed connection for the expansion relief valve
1	Gas isolation valve
1	Gas connection pipe, 15 mm diameter
1	Domestic hot water connection pipe
1	Cold water connection pipe, 15 mm diameter
3	Service valve
2	Heating flow and return connection pipe, 20 mm diameter
2	Bag with small parts
1	Condensate discharge hose
1	Manual filling device with Double Check Valve
1	Mounting template
1	Enclosed documentation

Dimensions

	A	B	C	D
VU 10	125 mm	352 mm	440 mm	720 mm
VU 15	125 mm	352 mm	440 mm	720 mm
VU 20	125 mm	352 mm	440 mm	720 mm
VU 25	125 mm	352 mm	440 mm	720 mm
VU 30	125 mm	352 mm	440 mm	720 mm
VU 35	125 mm	386 mm	440 mm	720 mm
VUW 20/26	125 mm	352 mm	440 mm	720 mm
VUW 25/32	125 mm	352 mm	440 mm	720 mm
VUW 30/36	125 mm	352 mm	440 mm	720 mm
VUW 30/40	125 mm	386 mm	440 mm	720 mm

Validity: Product without integrated hot water generation

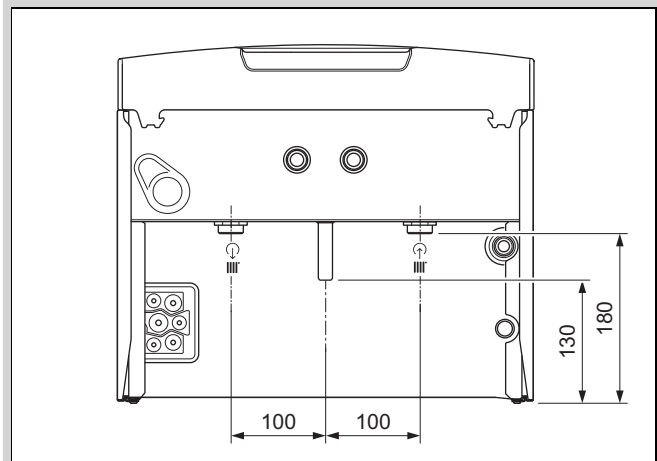

Validity: Product with integrated hot water generation

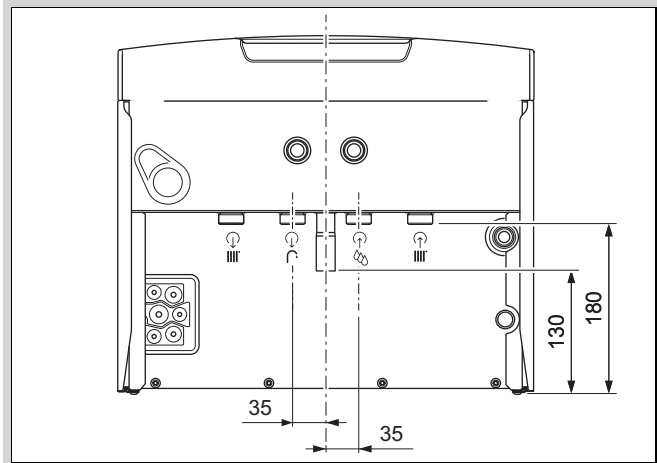

6.2 Product dimensions

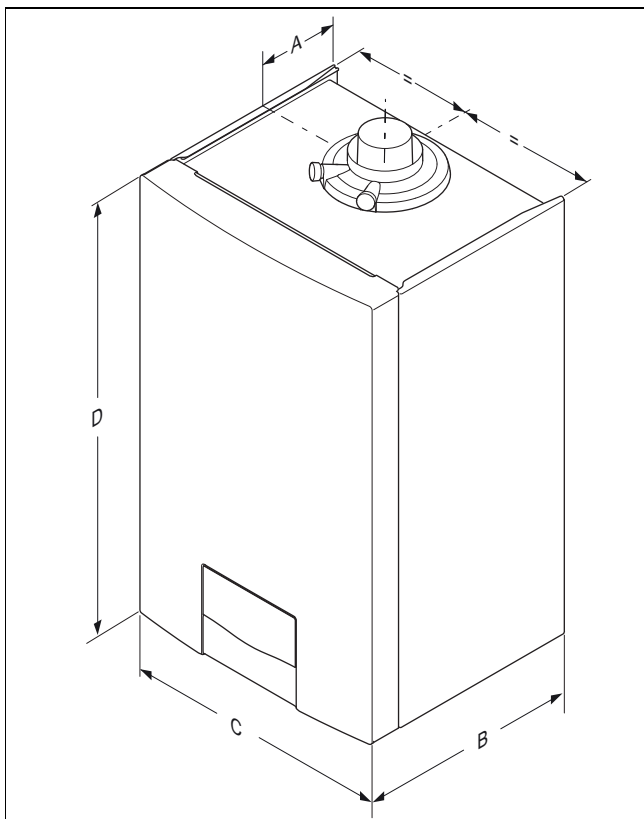

6.3 Installation site

This boiler is not suitable for outdoor installation. This boiler may be installed in any room. However if the boiler is being installed in a room containing a bath or shower it must only be installed in zones 2 or 3. In GB this is the current I.E.E. WIRING REGULATIONS and BUILDING REGULATIONS. In IE reference should be made to the current edition of I.S.813 "Domestic Gas Installations" and the current ETCI rules.

If the boiler is to be installed in a timber frame building it should be fitted in accordance with the current version of the Institute of Gas Engineers document IGE/UP/7. If in doubt seek advice from local building control.

6.4 Minimum clearances

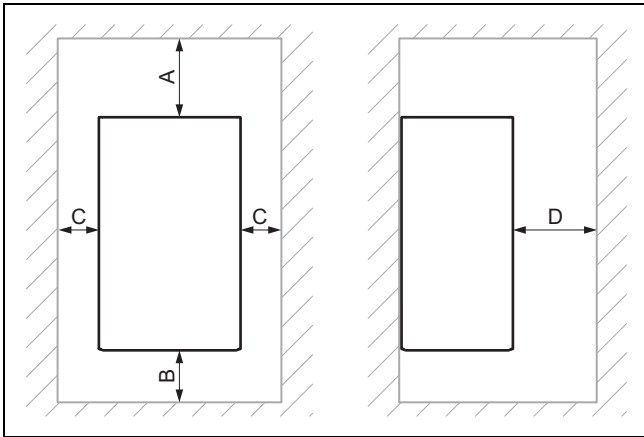

	Minimum clearance
A	60/100 mm diameter air/flue pipe: 165 or 248 mm. → See mounting template 80/125 mm diameter air/flue pipe: 276 mm
B	180 mm
C	5 mm
D	500 mm in front of the heat generator to enable easy access for maintenance work (may be provided by an opening door)

6.5 Compartment Ventilation

The boilers are very high efficiency appliances.

As a consequence the heat loss from the appliance casing during operation is very low.

Compartment ventilation is not required if the product is fitted with a concentric flue system.

6.6 Using the mounting template

- ▶ Use the mounting template to set the positions of the drill holes, wall penetrations and to read all of the required clearances.

6.7 Wall-mounting the product

1. Ensure that the wall or wall-mounting apparatus (e.g. individual stands) has a sufficient load-bearing capacity.
2. Use approved fixing material to secure the unit mounting bracket.



Note

Use suitable fixing material, in accordance with the structure of the wall on-site, for a load-bearing capacity of 100 kg.

The supplied fixing material is suitable only for walls made from concrete and solid bricks.

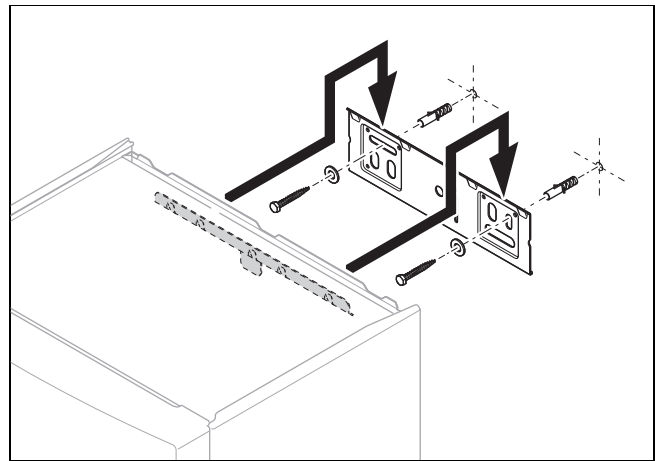

3. Wall-mount the product on the unit mounting bracket.

7 Installation

7.1 Prerequisites

7.1.1 Gas supply

In the planning phase, consult the local gas supply company in order to guarantee the availability of sufficient gas supply. An existing gas supply line must NOT be used without consulting the local gas supply company first. The product must only be connected to a gas supply with a regulated gas meter. A gas meter must only be installed by the local gas supply company or a registered Gas Safe Engineer. In Ireland, it must only be installed by a registered Gas Installer (RGII).

An existing gas meter should preferably be checked by the gas supply company in order to ensure that the gas meter is suitable for supplying the required gas volume. The competent person is responsible for designing the gas pipelines in compliance with BS 6891.

If we assume an acceptable pressure loss of 1 mbar for the gas pipelines to the unit, we can assume a maximum permissible operating pressure of 18 mbar at the product's gas inlet (Reference BS 6400-1 Clause 6.2 Pressure Absorption).

Use a gas leak-tightness test to ensure that all connections for the gas valve assembly to the gas control valve are gas-tight. Gas pipelines must be installed correctly in compliance with BS 6891. In Ireland, they must be installed in compliance with IS 813. The entire installation MUST be checked for gas tightness and be purged in accordance with the specifications in the listed standards.

7.1.2 Information about the gas group

The product is authorised to be operated with all of the gas types that are listed in the gas boiler category, see technical data. In the as-supplied condition, the product must only be operated with gases of the gas type and/or the gas group for which they are set, which can be seen on the data plate.

If the product is approved for operation with a different gas family, you can convert to the new gas family and gas type. (→ Section 9.18)

7.1.3 Using the correct gas type

Operating with a gas type from the incorrect gas family, may cause fault shutdowns in the product. Ignition and combustion noise may occur in the product.

- ▶ Only use gases from the gas group and gas family that are specified on the data plate.

7.1.4 Carrying out basic preparation for the installation

1. Make sure that the existing gas meter is capable of passing the rate of gas supply required.
2. Consider the maximum heat output given in DHW mode.
3. Protect the potable water correctly by using a suitable and approved filling device. Depending on the unit version, a filling device is included in the scope of delivery.
4. Install the following components:
 - Draining cocks at the lowest points in the heating installation (→ current version of BS 2879)
 - A stopcock on the cold water connection
 - A stopcock in the gas pipe
5. Install the connection pipes such that they are free from mechanical stress.
6. If you use non-diffusion-tight plastic pipes in the heating installation, ensure that no air gets into the heat generator circuit.
7. Only solder connectors if the connectors are not yet screwed to the service valves.
8. Only carry out work on components once they have cooled down.
9. Only bend connection pipes if they have not yet been connected to the product.
10. Flush the heating installation thoroughly before installing the product.
11. If, during gas leak-tightness tests, you also place the gas pipes and the gas valve assembly in the product under pressure, use a max. test pressure of ≤ 11 kPa (110 mbar).
12. If you cannot limit the test pressure to 11 kPa (110 mbar), close any gas stopcocks that are installed upstream of the product before you carry out the gas leak-tightness test.
13. If, during gas leak-tightness tests, you have closed the gas stopcock that is installed upstream of the product, relieve the gas line pressure before you open this gas stopcock.
14. Insulate bare pipes exposed to environmental influences to protect them from frost using suitable insulating material.

7.1.5 Pressure maintenance in the heating installation

Heating installations are sealed systems. Air flows in a system's heating circuit are disruptive factors that have negative effects. To prevent air from getting into the system, excess pressure is built up against the atmospheric pressure, and this must be maintained. Excess pressure and temperature fluctuations in the heating circuit are offset by a diaphragm expansion vessel.

The product is fitted with a diaphragm expansion vessel. During the installation, you must check whether the volume of this diaphragm expansion vessel is sufficient for the heating installation.



Note

The subsequent check is an approximation method, which does not replace a detailed technical design. The result only provides a rough guide for whether the installed diaphragm expansion vessel with a volume of 10 l is sufficient or whether an additional external expansion vessel is required.

The following database is based on the diagram below:

- Pure heating water without added frost protection
- Average temperature 55 °C
- Initial pressure 0.05 MPa (0.5 bar)
- Final pressure 0.25 MPa (2.5 bar)

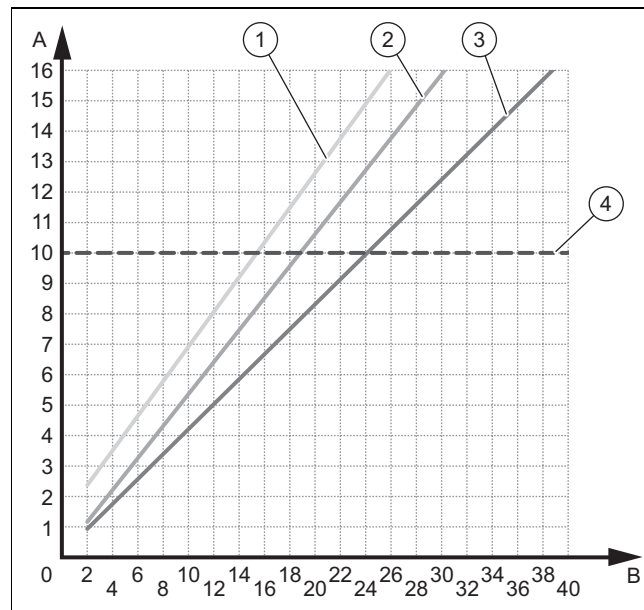

A	Expansion vessel	2	Radiators made from pipes or steel
B	Installed heat output in kW	3	Radiators made from cast iron
1	Underfloor heating	4	Nominal volume of the installed expansion vessel

- ▶ Determine the following values.
 - Installed heat output in kW
 - Heating system: Radiators made from cast iron, radiators made of pipes or steel, or underfloor heating
- ▶ Starting from the installed heat output in a vertical line upwards, determine the intersection point with the curve for the relevant heating system.
 - ◁ If the intersection point lies below the dotted line for the installed expansion vessel, it may be the case that no additional external expansion vessel is required.
 - ◁ If the intersection point lies above the dotted line for the installed expansion vessel, it is probable that an additional external expansion vessel is required.
- ▶ If an external expansion vessel is required for the correct pressure maintenance in the heating installation, install it in the heating return as close as possible to the product.

Validity: Product with integrated hot water generation

Condition: External expansion vessel installed and warm start active

- ▶ Install a non-return valve in the product outlet (heating flow) or decommission the internal expansion vessel in order to prevent the warm start function from being increasingly activated due to backflow.

7.1.6 Softening water

For hard potable water with a degree of hardness of >15 °dH (267 ppm CaCO_3 ; 2.67 mol/m^3), it may make sense to soften or stabilise the water or, in the case of domestic hot water, this may be necessary in order to protect the potable water installation.

Scale deposition increases as the water temperature increases.

- ▶ Check whether the potable water may need to be softened and, if required, soften the water.
- ▶ Use one of the technical options that complies with the recognised rules of technology.

7.2 Installing the air/flue pipe

7.2.1 Room-sealed air/flue pipe



Note

This product range is only permitted for the C13, C33, C43 and C53 unit types. Only room-sealed installation is therefore permitted. Combustion air supply from the installation room and adjacent rooms is not permitted. The combustion air must be supplied from outside of the building.

7.2.2 Regulation

Different flue outlet configurations can be carried out.

- Consult the installation manual for air/flue gas systems for more information about the other possibilities and associated accessories.

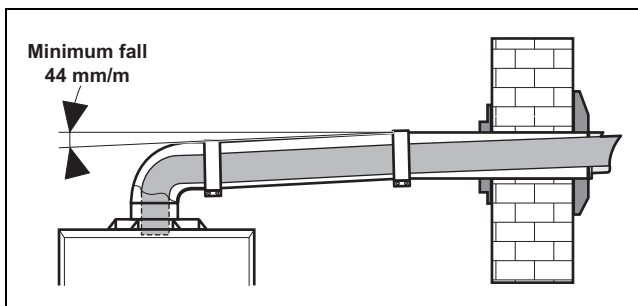

- Standard flue terminal kits have an in-built fall back to the boiler to drain the condensate. These can be fitted level between the appliance and the termination position. All other extended flues must have a fall of at least 44 mm/m.

The maximum length of the flue outlet is defined according to its type (for example C13).

- Whatever the kind of flue system chosen, observe the minimum distances to position the flue terminals.
- To install the flue, refer to the separate flue instruction supplied with your appliance.
- Explain these requirements to the user of the appliance.

In GB the minimum acceptable siting dimensions for the terminal from obstructions, other terminals and ventilation openings are shown in diagram overleaf.

In IE the minimum distances for flue terminal positioning must be those detailed in I.S. 813 “Domestic Gas Installations”.

The terminal must be exposed to the external air, allowing free passage of air across it at all times.

Being a condensing boiler some plumbing may occur from the flue outlet. This should be taken into consideration when selecting the position for the terminal.

7.2.3 Position of the air/flue terminal

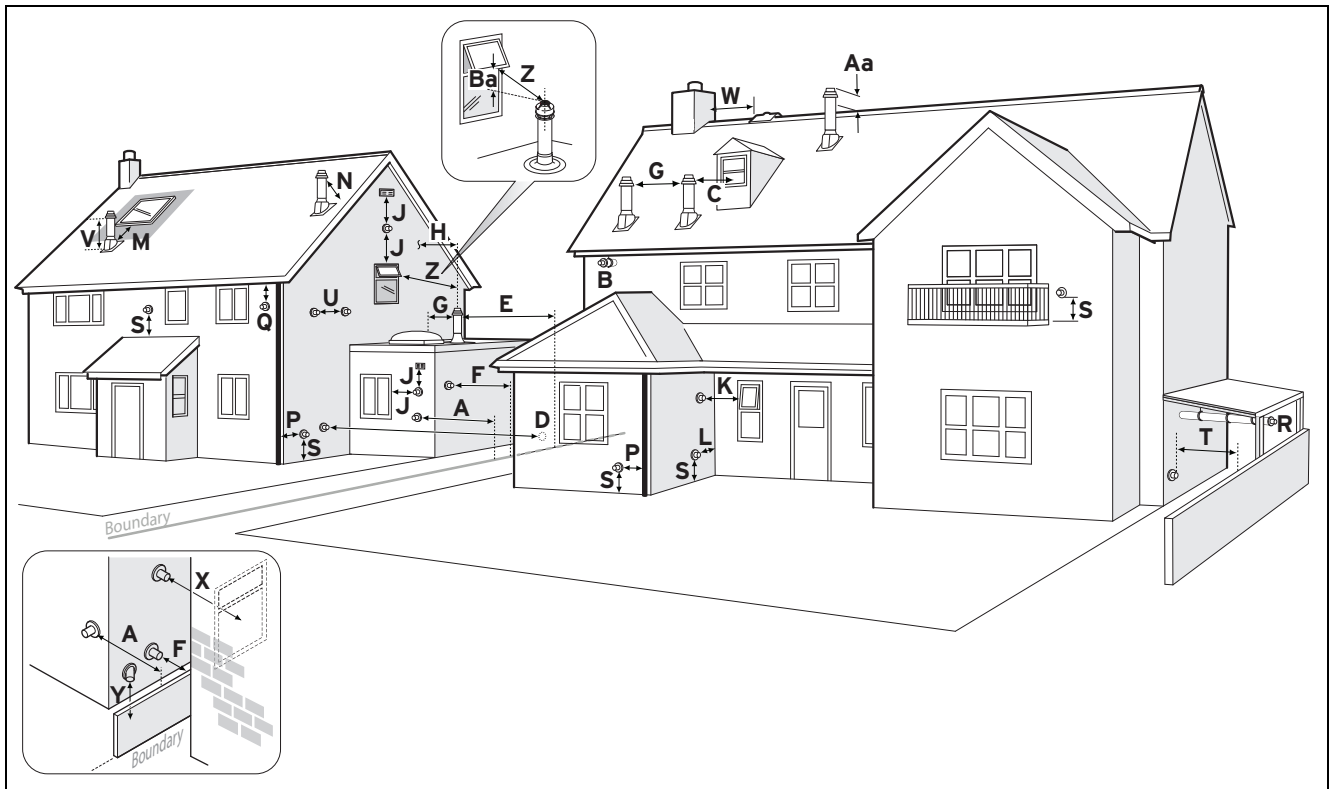

7.2.3.1 Positioning the terminal of a fan-supported flue system

	Installation site	Dimensions
A	Adjacent to a boundary.	300 mm
B ¹⁾	The dimension below eaves, balconies and car ports can be reduced to this value, as long as the flue terminal is extended to clear any overhang. External flue joints must be sealed with a suitable silicon sealant.	25 mm
C	Between a vertical flue terminal and a window or dormer window on a roof.	1,500 mm
D	Between terminals facing each other.	1,200 mm
E	Vertical flue clearance, adjacent to a boundary line.	300 mm
F ²⁾	Distance to a boundary line, unless it will cause a nuisance. BS 5440:Part 1 recommends that care is taken when siting terminal in relation to boundary lines.	600 mm
G	Minimum clearance from a skylight to a vertical flue or to another vertical flue.	Min. 300 mm
H	Vertical flue clearance, to noncombustible building material. Vertical flue clearance to combustible building material.	500 mm 1,500 mm
J	Above, below and either side of an opening door, air vent or opening window.	300 mm
K	Diagonally to an opening door, air vent or opening window.	600 mm
L ²⁾	To an internal or external corner. This dimension can be reduced if a plume diverter is used.	200 mm
M	Below a Velux window. Above or to either side of the Velux window.	2,000 mm 600 mm
N	From a pitched roof. In regions with heavy snowfall.	400 mm 500 mm
P	From vertical drain pipes and soil pipes.	25 mm
Q	Below eaves. Below gutters, pipe and drains.	200 mm 75 mm
	<p>1) There should be no ventilation/opening in the eaves within 300 mm distance of the terminal.</p> <p>2) These dimensions comply with the building regulations, but they may need to be increased to avoid wall staining and nuisance from pluming depending on site conditions.</p> <ul style="list-style-type: none"> - Terminals must be positioned so to avoid combustion products entering the building. - Support the flue at approximately one metre intervals and at a change of direction, use suitable brackets and fixings. - Installations in car ports are not recommended. - The flue cannot be lower than 1 metre from the top of a lightwell due to the build up of combustion products. - Dimensions from a flue terminal to a fanned air inlet to be determined by the ventilation equipment. 	

	Installation site	Dimensions
R	The dimension below eaves, balconies and car ports can be reduced to this value, as long as the flue terminal is extended to clear any overhang. External flue joints must be sealed with suitable silicon sealant.	25 mm
S	Above adjacent ground or balcony.	300 mm
T ²⁾	Distance to a surface facing a terminal, unless it will cause a nuisance. BS 5440: Part 1 recommends that care is taken when siting terminals in relation to surfaces facing a terminal.	600 mm
U	Clearance alongside another terminal.	300 mm
V	Above roof level.	300 mm
W	Minimum to vertical structure on roof, roof vent.	Min. 300 mm
X	Minimum to opening in adjacent building.	Min. 2000 mm
Y	Minimum at an angle to a boundary which is not less than 300 mm to the terminal	Min. 600 mm
Z	Minimum measured to the nearest corner of the OPEN window	Min. 600 mm
Aa	No more than this value above ridge.	Max. 300 mm
Ba	Not less than this value below the opening window	Min. 300 mm
	1) There should be no ventilation/opening in the eaves within 300 mm distance of the terminal. 2) These dimensions comply with the building regulations, but they may need to be increased to avoid wall staining and nuisance from pluming depending on site conditions. <ul style="list-style-type: none"> - Terminals must be positioned so to avoid combustion products entering the building. - Support the flue at approximately one metre intervals and at a change of direction, use suitable brackets and fixings. - Installations in car ports are not recommended. - The flue cannot be lower than 1 metre from the top of a lightwell due to the build up of combustion products. - Dimensions from a flue terminal to a fanned air inlet to be determined by the ventilation equipment. 	

7.2.3.2 Horizontal terminal positioning

BS 5440-1 recommends that fanned flue chimney terminals should be positioned as follows:

- a) at least 2 m from an opening in the building directly opposite, and
- b) so that the products of combustion are not directed to discharge directly across a boundary if the products are likely to cause a nuisance to a neighbour or discharge over a walkway or patio.

For IE see current issue of IS 813.

For boilers covered within this manual.

Dimensions B and R:

These clearances may be reduced to 25 mm without affecting the performance of the boiler. In order to ensure that the condensate plume does not affect adjacent surfaces the terminal should be extended as shown below.

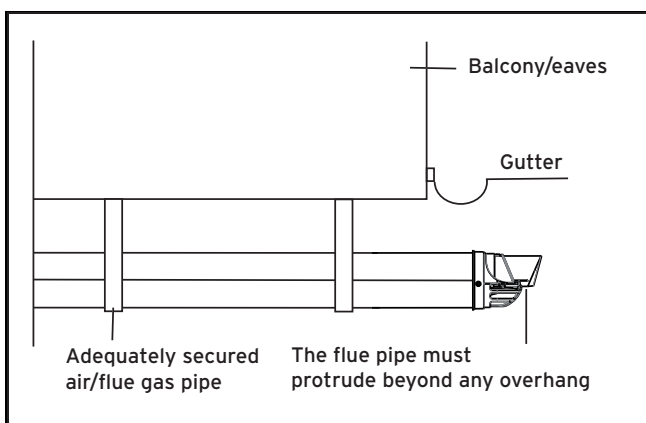

You can use a plume management kit to enable the termination point to be positioned and directed away from the building fabric.

7.2.4 Flue Configuration Description

7.2.4.1 Horizontal Concentric Flue \varnothing 60/100 mm or \varnothing 80/125 mm (C13 type installation)

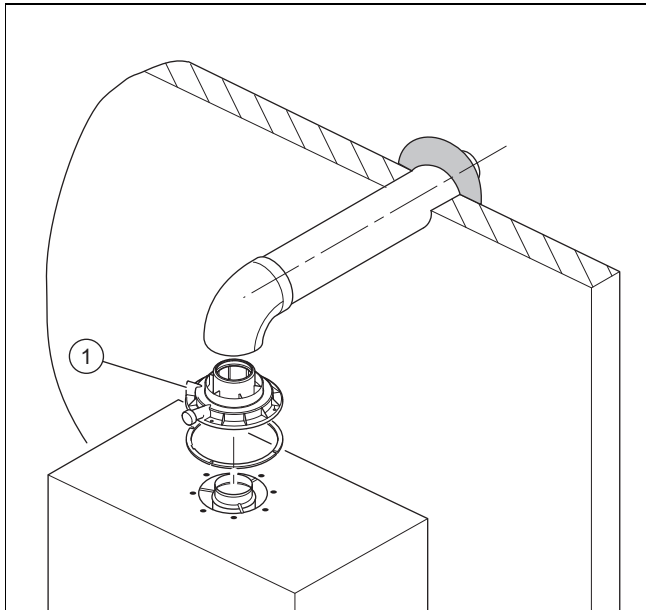

1 Gasket (fitted)



Note

If the terminal is at less than 2.0 m from the ground, you must install a terminal protection kit.

Consult the separate installation manual for air/flue gas systems supplied with your appliance for all possibilities and associated accessories and how to install the flue system.

7.2.4.2 Terminal protection

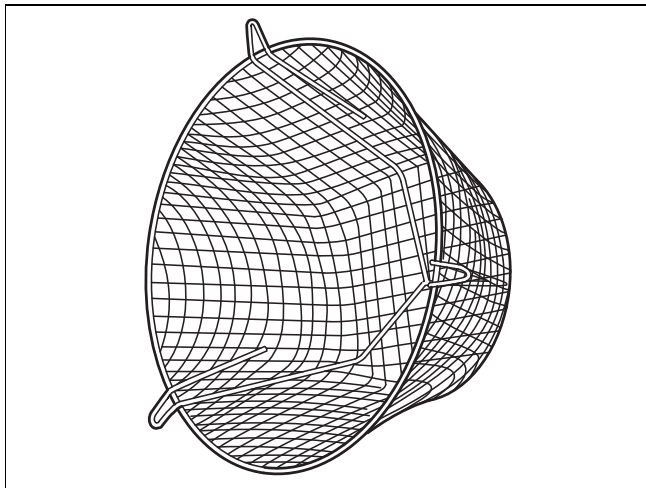

A terminal guard is required if persons could come into contact with the terminal or the terminal could be subject to damage.

If a terminal guard is required, it must be positioned to provide minimum of 50 mm clearance from any part of the terminal and be central over the terminal.

The guard should be stainless and similar to that shown in the figure.

7.2.4.3 Vertical Concentric Flue \varnothing 60/100 mm or \varnothing 80/125 mm (C33 type installation)

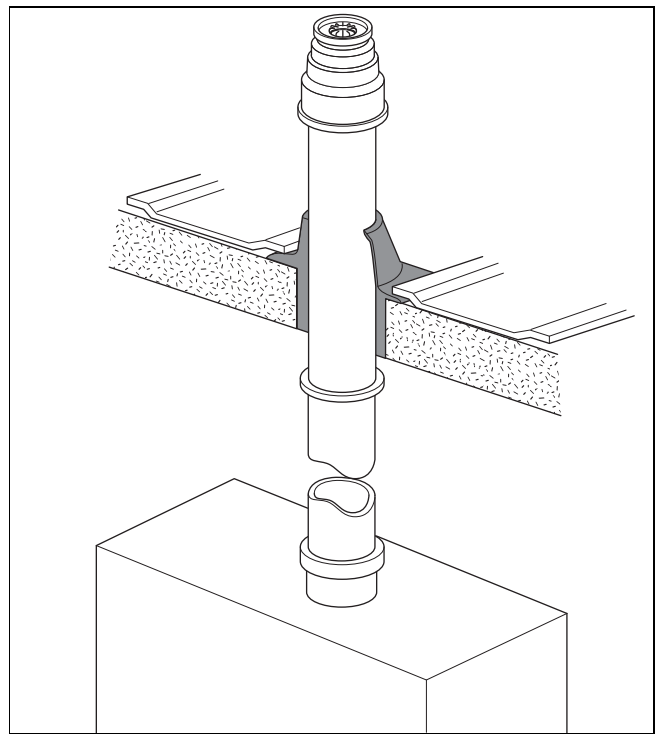

Consult the separate installation manual for air/flue gas systems supplied with your appliance for all possibilities and associated accessories and how to install the flue system.

7.2.5 Installing and connecting the air/flue pipe

1. You can find out which air/flue pipes may be used by consulting the enclosed set-up instructions for the air/flue system.
2. Observe the information on positioning the air/flue terminal.

Condition: Installation in damp rooms

- You must connect the product to a room-sealed air/flue system. The combustion air must not be taken from the installation site.



Caution.

Risk of poisoning due to escaping flue gas.

Mineral-oil-based greases can damage the seals.

- Instead of grease, use only water or commercially available soft soap to aid installation.

3. Install the air/flue pipe using the set-up instructions.

7.2.6 Replacing the standard connector for the air/flue pipe, where required

7.2.6.1 Removing the standard connector for the air/flue pipe

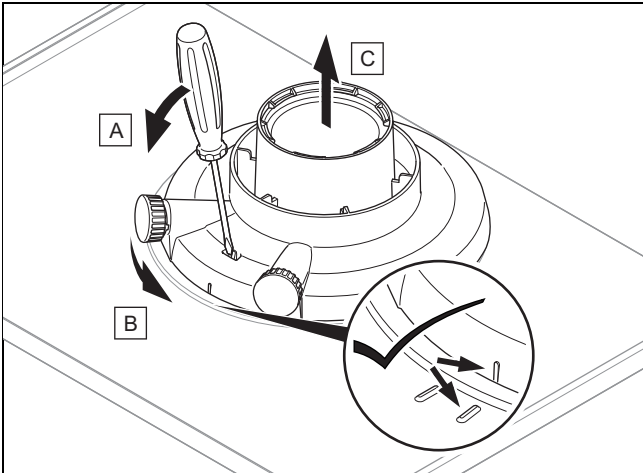

7.2.6.2 Installing the connector for the air/flue pipe, 60/100 mm or 80/125 mm diameter

1. Remove the standard connector for the air/flue pipe. (→ Section 7.2.6.1)
2. Insert the alternative connector. In doing so, pay attention to the latching lugs.
3. Turn the standard connector clockwise until it clicks into position.

7.3 Installing the gas connection

- ▶ Install the gas pipe in accordance with the recognised rules of technology.
- ▶ Remove the residues from the gas pipe by decoupling on both sides and blowing through the gas pipe.
- ▶ Use the enclosed gas isolation valve. Observe the specified flow direction.



Note

Gas isolation valves with or without test nipple are available in the dimensions 15 to 15 mm or 22 to 15 mm.

Condition: Gas isolation valve without test nipple

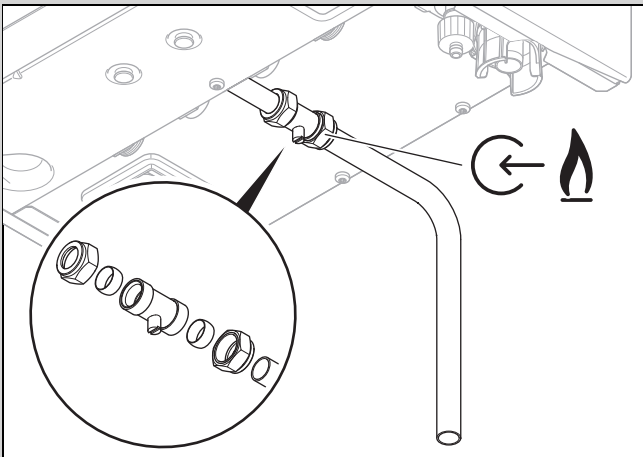

- ▶ Connect the product to the gas pipe as shown in accordance with the recognised rules of good engineering practice.

Condition: Gas isolation valve with test nipple (requirement for BS 6891)

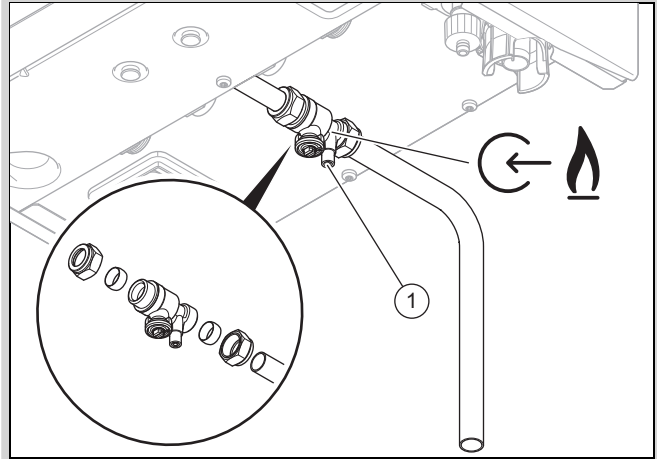

- ▶ Connect the product to the gas pipe as shown in accordance with the recognised rules of good engineering practice.
- ▶ Always ensure that the test nipple (1) is sealed and is correctly checked for tightness. Tightening torque, see appendix.

– Working materials: 3 mm hex key

- ▶ Purge the gas pipe before start-up.
- ▶ Check the entire gas supply for tightness in accordance with the relevant standards.

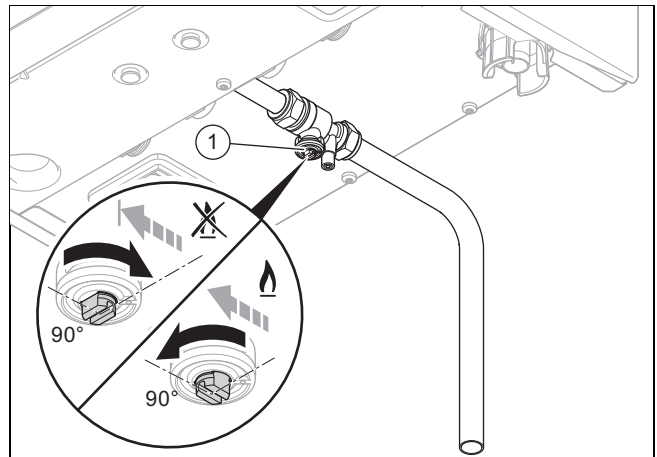

- ▶ Turn the gas isolation valve (1) by a 90° rotation:
 - Open: Rotate by 90° anti-clockwise
 - Close: Rotate by 90° clockwise



Note

To isolate, only use the mechanism that is provided by the gas isolation valve. Any change, wear or damage to a part of the gas isolation valve means that the fitting no longer complies with the performance requirements of the standard and it must be completely replaced.

Technical data – gas isolation valves

Technical data in accordance with EN 331	Article number 082778 15–15 mm	Article number 0020325741 15–15 mm Test nipple	Article number 082786 15–22 mm	Article number 0020325742 15–22 mm Test nipple
Nominal diameter	DN 8	DN 8	DN 12	DN 12
Pressure class (MOP)	0.5	0.5	0.5	0.5
Temperature class	-20 °C	-20 °C	-20 °C	-20 °C
Manual operation part	Cannot be removed	Cannot be removed	Cannot be removed	Cannot be removed
Flow direction	See product	See product	See product	See product
Date of manufacture	See product	See product	See product	See product
Cert-PIN	755170	776439	755170	776439

7.4 Installing the hot and cold water connection

Validity: Product with integrated hot water generation

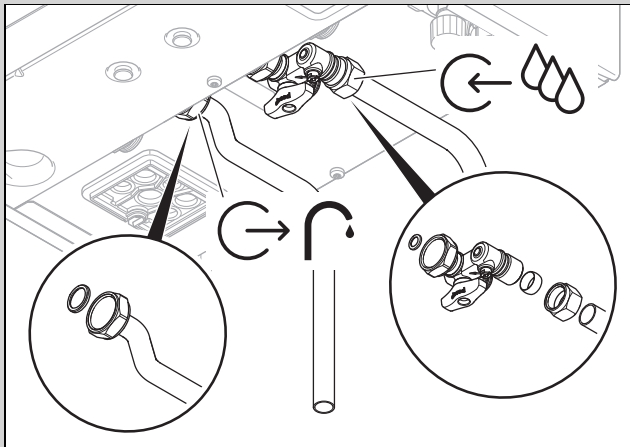

1. Make the water connections as shown in accordance with the relevant standards.
2. Ensure correct water pressure and flow requirements and that any expansion can be accommodated with the cold supply pipe work.

7.5 Connecting the domestic hot water cylinder

Validity: Product with connected domestic hot water cylinder

- ▶ When connecting the domestic hot water cylinder, follow the Installation instructions for the domestic hot water cylinder.

7.6 Installing the heating flow and heating return

Validity: Product with connected domestic hot water cylinder

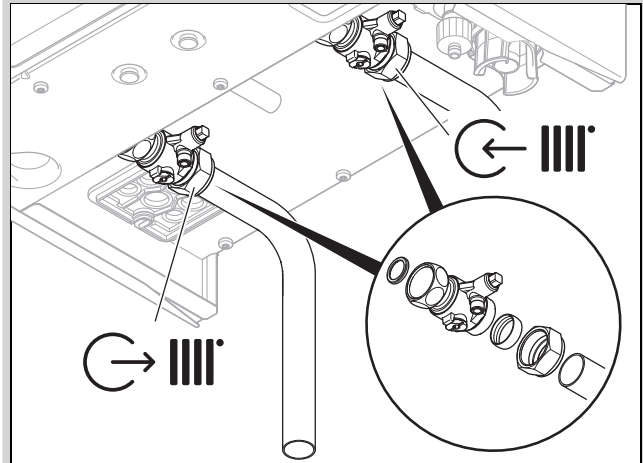

- ▶ Make the heating connections as shown in accordance with the relevant standards.

7.7 Installing the heating flow and heating return

Validity: Product with integrated hot water generation

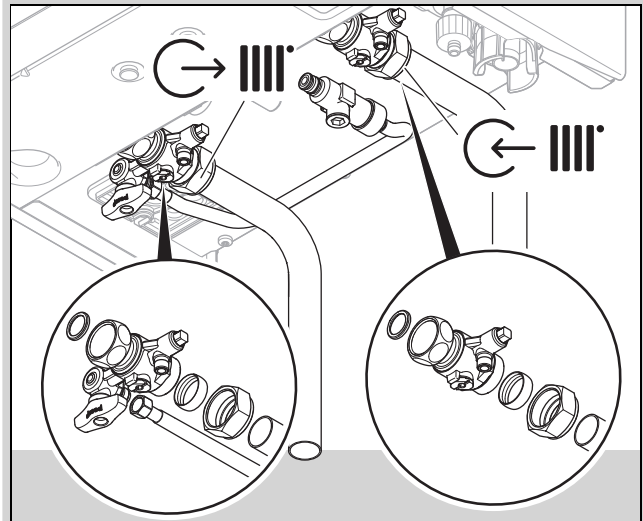

- ▶ Make the heating connections as shown in accordance with the relevant standards.

7.8 Installing the condensate discharge



Note

Failure to install and commission according to the manufacturers' instructions and complete this Benchmark Commissioning Checklist will invalidate the warranty. This does not affect the customer's statutory rights.

The product is equipped with a condensate siphon.

For filling and cleaning, an installation space of at least 180 mm is required below the condensate siphon.

- ▶ Use only pipes made of acid-resistant material (e.g. plastic overflow pipe) for the condensate discharge pipe. If you cannot guarantee that the materials from which the condensate discharge pipe is made are suitable, install a system to neutralise the condensate.

- ▶ For the condensate discharge pipe, use pipes that have an internal diameter of at least 19 mm (30 mm internal diameter for all of those that are led out of the building).
 - The condensate discharge pipework must have a continuous fall (45 mm per metre) and should whenever possible terminate at a suitable discharge point within the heated envelope of the building that will remain frost free under long periods of low external temperatures.



Note

Ensure that the connection between the condensate discharge pipe and a sewage pipe is not air-tight.

- ▶ During installation remove all burrs from inside of cut pipe work and avoid excessive adhesive which may trap small pockets of water close to the pipe wall which can freeze and build into a larger ice plug.
- ▶ As with other pipe work insulate the condensate discharge pipe to minimise any risk of freezing and beware when crossing cavities that the fall is maintained and the pipe sleeved.
- ▶ Ensure that the condensate discharge pipe terminates in a suitable location. Further information can be obtained from BS 6798 Specification for installation of gas-fired boilers of rated input not exceeding 70 kW net.
- ▶ Follow the instructions listed here and observe directives and local regulations on condensate discharge.

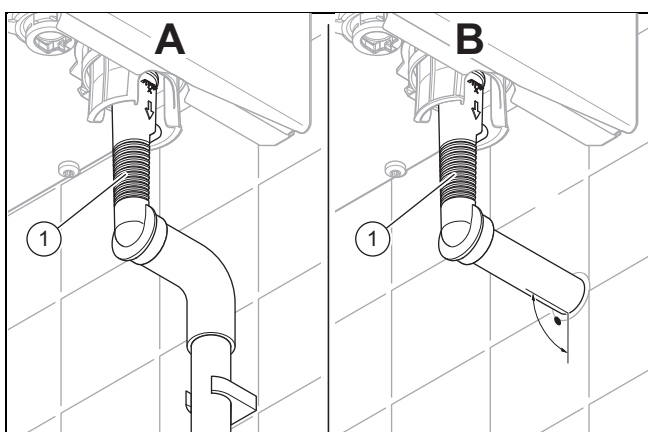

- ▶ To connect the condensate discharge pipe to the condensate siphon, use the condensate adapter (1) from the bag of small parts (recommendation). Follow the enclosed installation instructions. The condensate adapter has aeration. However, avoid a tight connection to a waste-water pipework. If you do not use the accessory from the bag of small parts, note that the connection to the siphon must not be rigid. You must install a removable part so that maintenance can be carried out on the siphon.
- ▶ Fill the condensate siphon. (→ Section 9.12)

Where preferential to do so, it is permitted to combine the outlets for condensate and pressure relief valve from the appliance outside the boiler casing. (→ Section 7.9)

7.8.1 Condensate discharge systems

It is not necessary to provide extra traps in the discharge pipe as there is already a trap inside the boiler. Fitting an extra trap may cause the boiler siphon to work incorrectly. Refer to BS5546 or BS6798 for further advice on disposal of boiler condensate.

7.8.1.1 Direct Connection to internal soil and vent stack

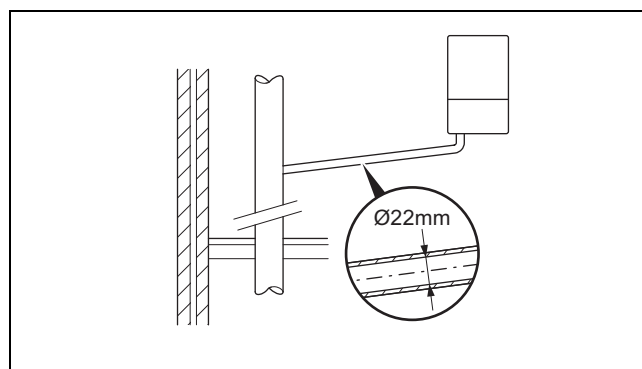

Preferred option

7.8.1.2 Direct connection to external soil and vent stack

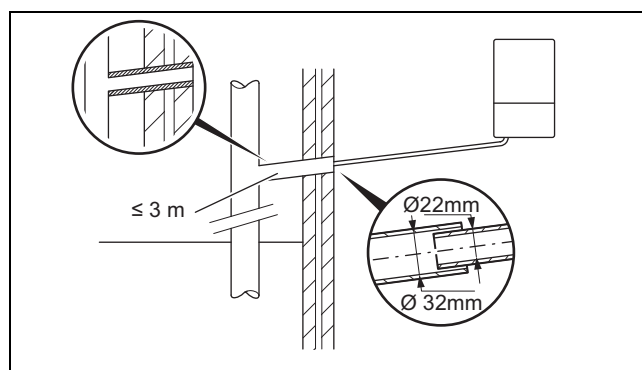

7.8.1.3 External termination to gully or hopper

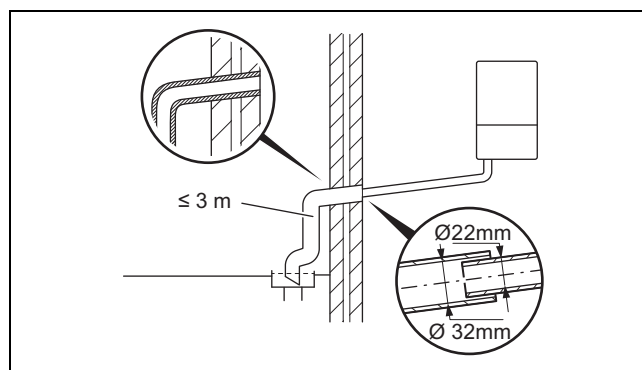

Best practice

7.8.1.4 Internal termination into combined sink waste

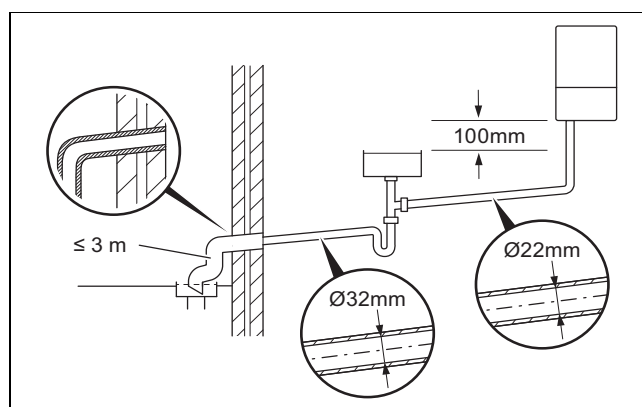

Preferred option for external termination

7.8.1.5 External termination into soakaway

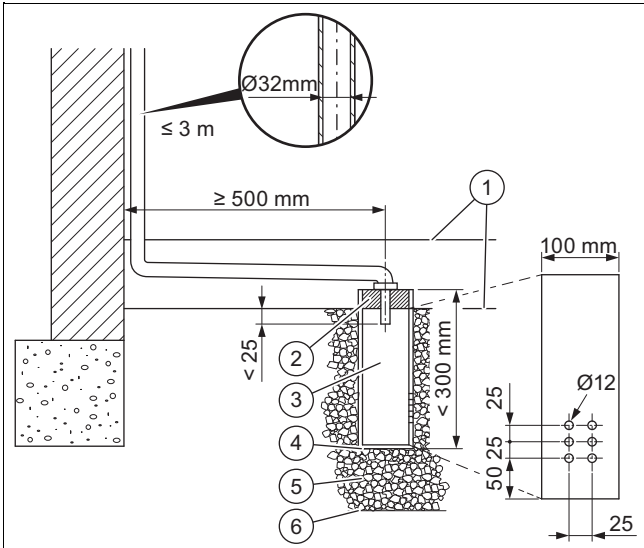

- | | | | |
|---|----------------------------------|---|------------------------------|
| 1 | Ground (either/or) | 4 | Bottom of sealed tube |
| 2 | Seal | 5 | Limestone chippings |
| 3 | Plastic tube,
100 mm diameter | 6 | Hole depth 400 mm
minimum |

Least preferred option, must not terminate in rain water drain

7.8.1.6 Internal termination downstream of sink waste

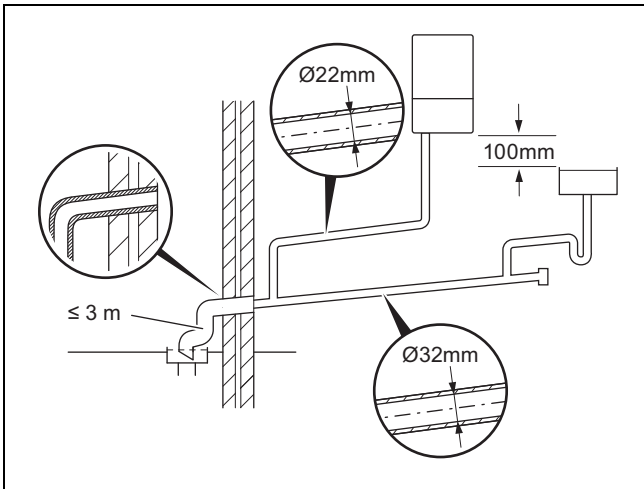

Open end of pipe direct into gully below ground level but above water level

Susceptible to siphonage, must terminate in a gully

7.8.1.7 External termination into rain water down pipe

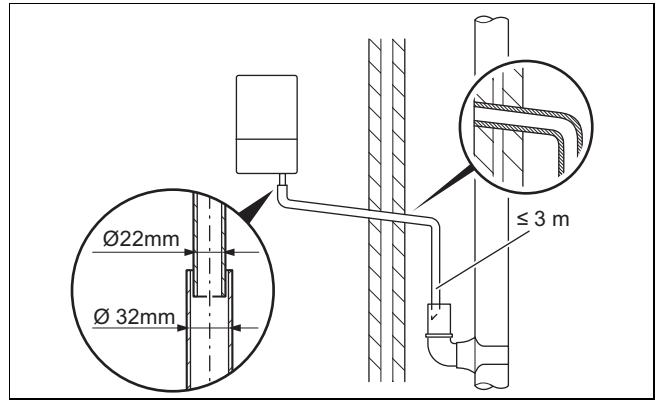

NB only combined foul/rainwater drain

7.8.1.8 Additional methods of introducing air breaks

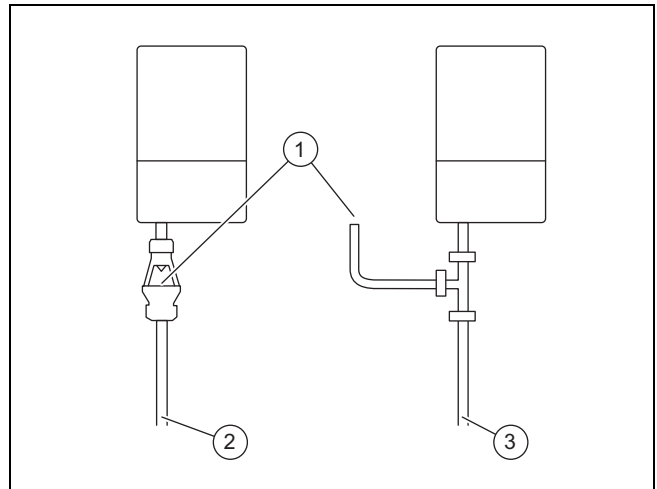

- | | | | |
|---|-----------------|---|--------------|
| 1 | Air break | 3 | Using a pipe |
| 2 | Using a tundish | | |

7.8.1.9 Connection of condensate pump

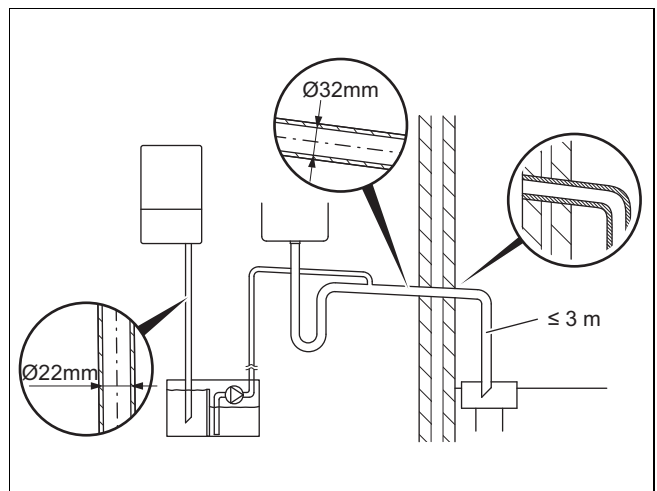

Preferred option for external connection

7.9 Installing combined condensate and pressure relief valve

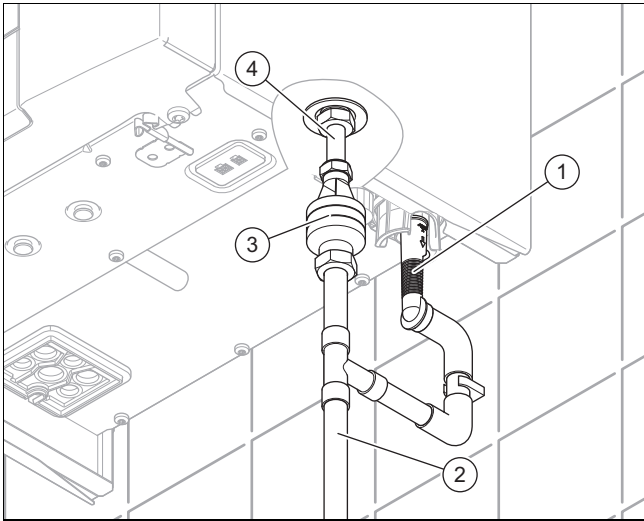

1. Install the drain pipe for the expansion relief valve (4) in such a way that it does not interfere with the removal and fitting of the lower section of the siphon.
2. Install common drain pipework (2) for the expansion relief valve's drain pipe and the condensate adapter (1) (→ Section 7.8).
3. This must be carried out in such a way that the pressure relief valve pipework does not come into contact with condensate. This can be achieved by connecting the pressure relief valve outlet above the outlet for condensate. See diagram. In accordance with BS6798:2014, the discharge from the pressure relief valve must be visible. This could be achieved directly by use of a tundish (3) or clear piping (if connecting to a soil stack it will require a second trap or sealed tundish or similar).
4. Ensure that discharged water or steam cannot cause injury to persons or damage to electronic components.
5. Ensure the discharge pipe work is installed, routed and terminated correctly to minimise the risk of freezing up.

7.10 Electrical installation

Only qualified electricians may carry out the electrical installation.



Danger! **Risk of death from electric shock!**

The power supply terminals L and N remain live:

- ▶ Disconnect the product from the power supply by switching off all power supplies at all poles (electrical partition with a contact gap of at least 3 mm, e.g. fuse or circuit breaker). Information on safe isolation can be found in the Health and Safety Executive guidance HSG85.
- ▶ Secure against being switched back on again.
- ▶ Wait for at least 3 minutes until the capacitors have discharged.

- ▶ Check that there is no voltage. Use test equipment approved to GS38 to confirm that the electricity supply is disconnected.

All work must comply with the current IET Wiring Regulations.

The isolator shall be situated next to the appliance for new systems and, where practicable, replacement appliances.

The mains electrical supply to the appliance must be through a fused double pole isolator.

Any additional components that are connected to the appliance that require 230 Volts must be connected to the same supply as the appliance.

External fuse 3 Amps.

When stripping the wires, ensure copper strands do not fall into the electronics box.

The product must be earthed.

7.10.1 Installing the product in a wet room



Danger! **Risk of death from electric shock!**

If you install the product in a room with high levels of moisture, e.g. a bathroom, observe the nationally recognised technical standards for electrical installations.

- ▶ Never use a connection cable with earthed plug when installing the product in a moist environment.
- ▶ Connect the product using a fixed connection and an electrical partition with a contact gap of at least 3 mm (e.g. fuses or power switches).
- ▶ Any switch or appliance control using mains electricity must not be within reach of a person using the bath or shower.

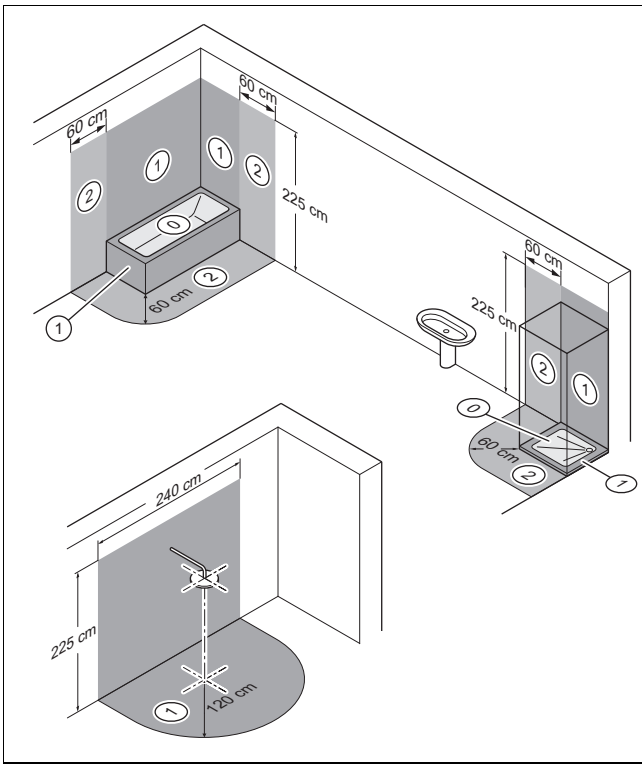

1. Install the product outside of zones 0 and 1 (BS 7671) (figure only used as a guide).
2. In all cases the installation must be in accordance with the latest amendments to the latest edition of the IET Wiring Regulations (BS 7671).
3. Check the IP rating of any control units to be used on this appliance.
4. Connect the product with a fixed connection. (→ Section 7.10.6)
5. For the power supply cable, use a flexible three-core cable that complies with the relevant standards, which is routed through the grommet into the product.
6. Connect the power supply cable to slot X1 on the PCB. (→ Appendix L)
7. Observe the correct installation when routing the power supply cable. (→ Section 13.7.15)
8. Ensure that the mains voltage is 230 V.
9. Install a suitable junction box.
10. Wire the power supply cable and the cable for the house installation within the junction box.
11. Observe the flue-gas connection that is required on a room-sealed air/flue system. (→ Section 7.2.5)

7.10.2 Removing the front casing

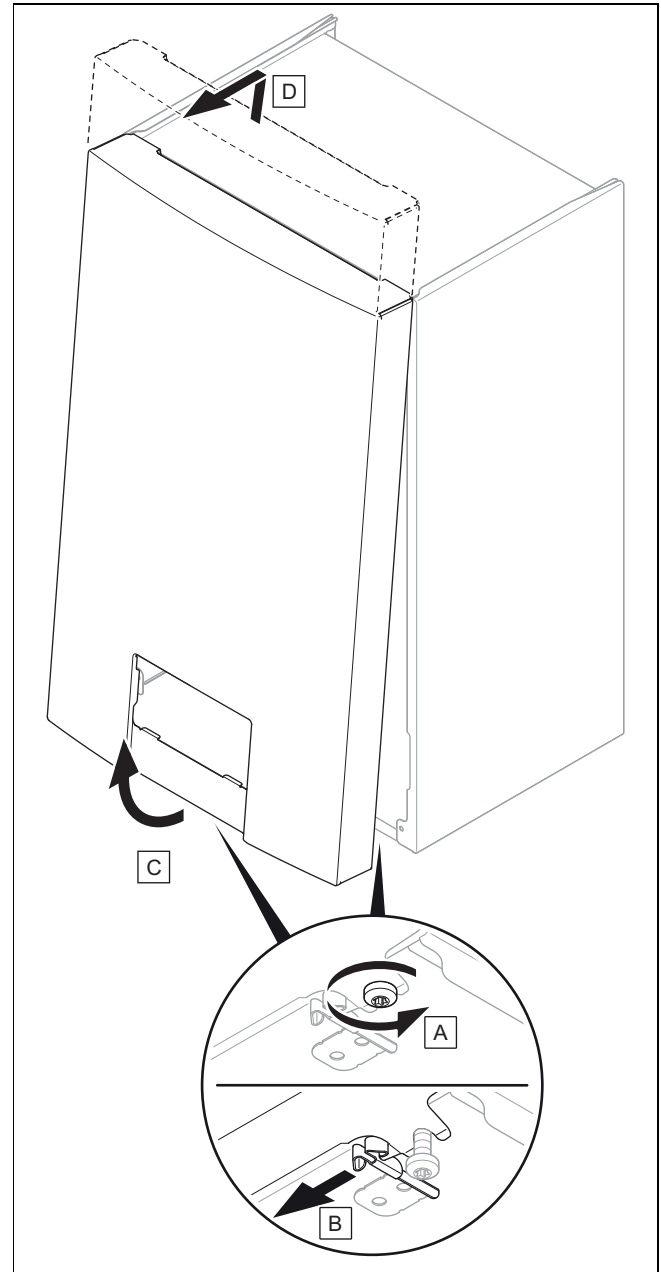

1. Loosen the two screws on the left and right on the underside of the product, but do not unscrew them completely.
2. Remove the front casing as shown in the illustration.

7.10.3 Opening the electronics box

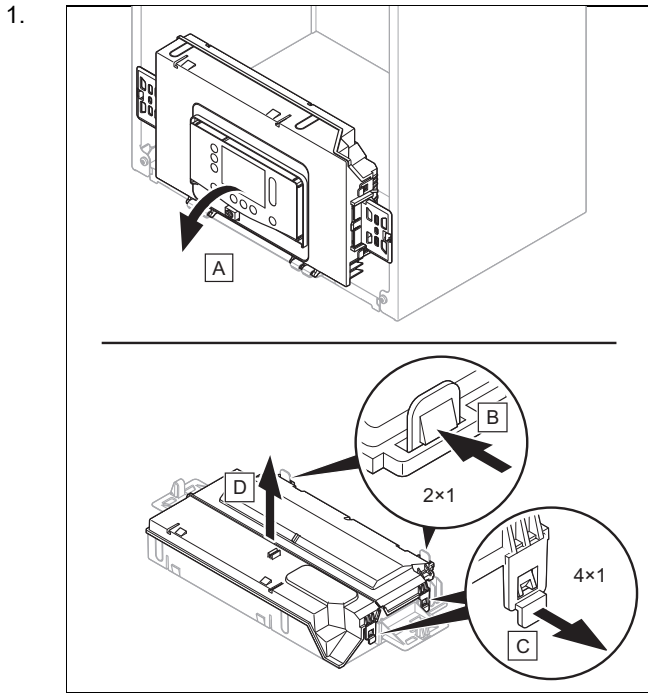

2. Ensure that you do not load the electronics box.

7.10.4 Closing the electronics box

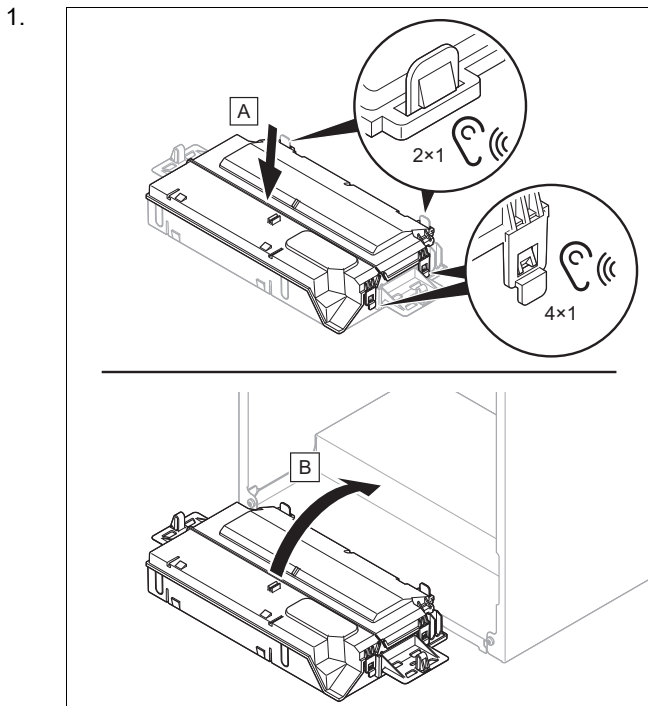

2. Ensure that the retainers on the right- and left-hand side of the electronics box have been installed correctly.

7.10.5 General information

7.10.5.1 Requirements for the mains voltage and sensor lines

Observe the following requirements for the mains voltage and sensor lines:

Line cross-section

Supply line for mains voltage (pump or mixer mains cable)	$\geq 1.5 \text{ mm}^2$ ($\geq 0.0023 \text{ in}^2$)
Sensor line (extra low voltage)	$\geq 0.75 \text{ mm}^2$ ($\geq 0.00116 \text{ in}^2$)

Line length

- Sensor lines: $\leq 50 \text{ m}$ ($\leq 164 \text{ ft} - 1 \text{ in}$)

7.10.5.2 Requirements for the eBUS line

Observe the following rules when routing the eBUS lines:

- ▶ Use twin-core cables.
- ▶ Never use shielded or twisted cables.
- ▶ Use only appropriate cables, e.g. NYM or H05VV (-F/-U).
- ▶ Observe the permissible total length of 125 m. For a total length of up to 50 m, a conductor cross-section of $\geq 0.75 \text{ mm}^2$ applies; from 50 m upwards, a conductor cross-section of 1.5 mm^2 applies.

In order to prevent faults in the eBUS signals (e.g. due to interferences):

- ▶ Maintain a minimum clearance of 120 mm to power supply cables or other electromagnetic sources of interference.
- ▶ For parallel routing to mains connection lines, guide the cables in accordance with the applicable regulations, e.g. on cable trays.
- ▶ **Exceptions:** For wall breaks and in the electronics box, it is acceptable to not reach the minimum clearance.

7.10.5.3 Feeding through and correctly routing the cable



Caution.

Risk of material damage caused by incorrect installation.

Mains voltage at incorrect terminals and plug terminals may destroy the electronics.

- ▶ Do not connect any mains voltage to the eBUS terminals (+/-).
- ▶ Only connect the connection cable to the terminals marked for the purpose.

1. For eBUS lines the wire type can be multi strand cable or solid core. There is no requirement for Cat 5 cable to be used.

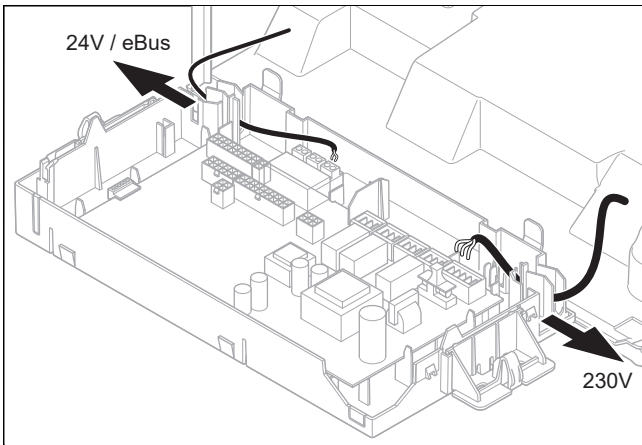

2. Correctly route the connection cables for the components that are to be connected in the electronics box: 24 V/ eBUS -> left-hand area, 230 V -> right-hand area.
3. Run power cables separately from signal cables. Interference from power cables may induce spurious faults on signal cables. Ensure that there is at least 100 mm separation from each other.
4. Ensure the cables are of sufficient length to allow the electronics box to be opened to the service position.
5. Use the strain reliefs in the electronics box.
6. If required, shorten the connection cables correctly.

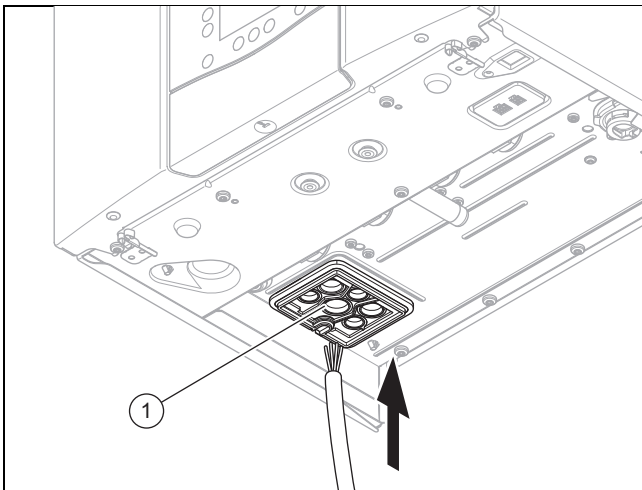

7. Route the connection cables of the components to be connected through the grommets (1) provided on the underside of the product on the left.
8. Ensure that the grommet is plugged in correctly and that the cables have been routed correctly.
9. Take care when piercing the grommets that an air gap isn't created once the wire has been fitted.

7.10.5.4 Stripping the cables correctly

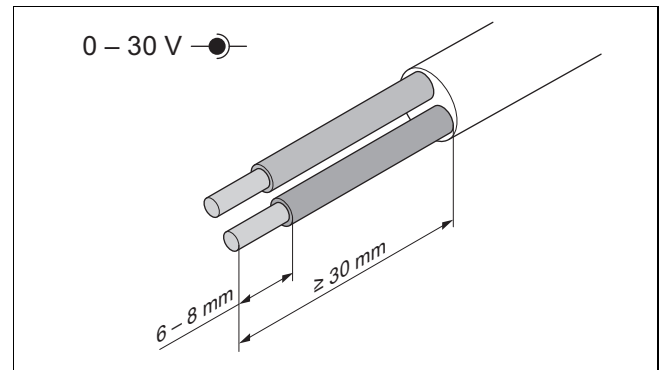
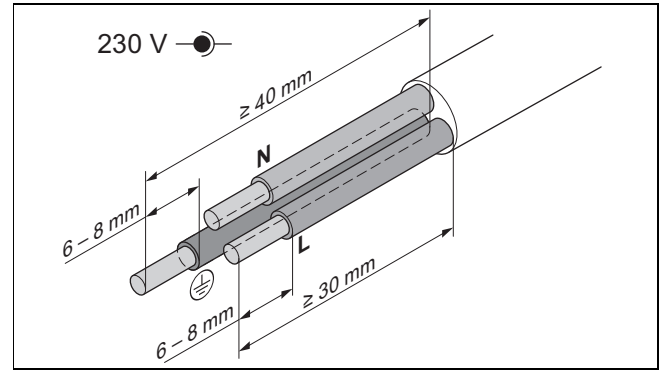

1. Strip the flexible cables as shown in the figure. In doing so, ensure that the insulation on the individual conductors is not damaged.
2. Only strip inner conductors just enough to establish stable connections.
3. When stripping the wires, ensure copper strands do not fall into the control box.
4. To avoid short circuits resulting from loose individual wires, fit conductor end sleeves on the stripped ends of the conductors.
5. Screw the respective plug to the connection cable.
6. Check whether all conductors are inserted mechanically securely in the plug terminals. Remedy this if necessary.
7. Plug the plug into the associated PCB slot. (→ Appendix L)

7.10.6 Connecting the product with a fixed connection



Caution.

Risk of material damage due to high connected voltage.

At mains voltages greater than 253 V, electronic components may be damaged.

- ▶ Make sure that the rated voltage of the mains is 230 V.

1. Observe all valid regulations.
2. Ensure that the mains voltage is 230 V.
3. Provide one common power supply for the boiler and for the corresponding control:



- Power supply: Single-phase, 230 V, 50 Hz
 - Fuse protection: ≤ 3 A
4. Do not interrupt the mains supply with a time switch or programmer.
 5. For the power supply cable, use a flexible three-core cable that complies with the relevant standards, which is routed through the grommet into the product.
 6. Connect the power supply cable to slot X1 on the PCB. (→ Appendix L)
 7. Observe the correct installation when routing the power supply cable. (→ Section 13.7.15)
 8. Ensure all electrical cables are in the correct cable guides and away from hot appliance components.
 9. Connect the product using a fixed connection and an electrical partition with a contact gap of at least 3 mm (e.g. fuses or power switches).
 10. Isolation should preferably be by a double pole switched fused spur box having a minimum contact separation of 3 mm on each pole. The fused spur box should be readily accessible and preferably adjacent to the boiler. It should be identified as to its use.

7.10.7 Connection options on the product

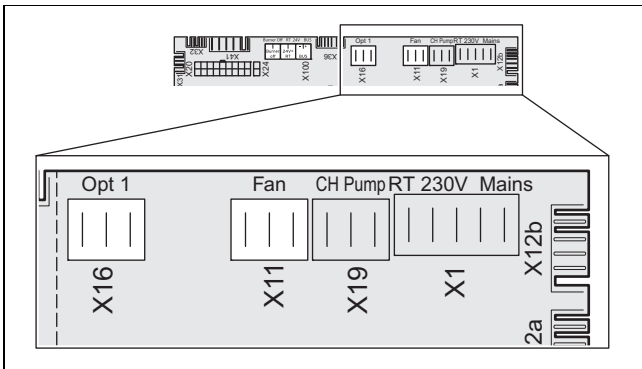
230 V connection area



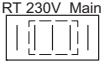
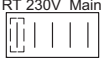

- 230 V power supply
- Optional relay on the PCB
- 230 V room thermostat

Slot	Item	Function
	X1	<p>main power supply 230 V input</p> <p>Caution. Risk of material damage due to high connected voltage. At mains voltages greater than 253 V, electronic components may be damaged.</p> <ul style="list-style-type: none"> ▶ Ensure that the mains voltage is 230 V ▶ Provide one common power supply for the boiler and for the corresponding control: <ul style="list-style-type: none"> - Power supply: Single-phase, 230 V, 50 Hz - Fuse protection: ≤ 3 A <ul style="list-style-type: none"> ▶ For the power supply cable, use a flexible three-core cable that complies with the relevant standards, which is routed through the cable duct into the product. ▶ Connect the product using a fixed connection and an electrical partition with a contact gap of at least 3 mm (e.g. fuses or power switches).
	X1	<p>230 V room thermostat control</p> <ul style="list-style-type: none"> ▶ Connect the switched live supply of your 230 V RT to the RT marked X1 position (besides LNPE). Do NOT connect the 230 V to any other terminal, e.g. X100.
	X16	<p>Optional relay (230 V)</p> <p>With diagnostic point D.026 you can use one function of 10 possible.</p> <ol style="list-style-type: none"> 1. External pump/ 2. Circulation pump/ 3. Solar cylinder bypass valve/ 4. Anti-legionella pump/ 5. eBUS remote control/ 6. Solar pump/ 7. External fault message/ 8. External solenoid valve/ 9. Extraction hood/ 10. Cylinder charging pump <p>Note</p> <p>An accessory is available in order to use two additional functions out of these ten potential functions.</p> <ul style="list-style-type: none"> ▶ Connect the connection cable for the external button to the terminals 1 ⊕ 0 and 6 (FB) on the X41 edge connector, which is included with the control. ▶ Plug the edge connector into PCB slot X41.

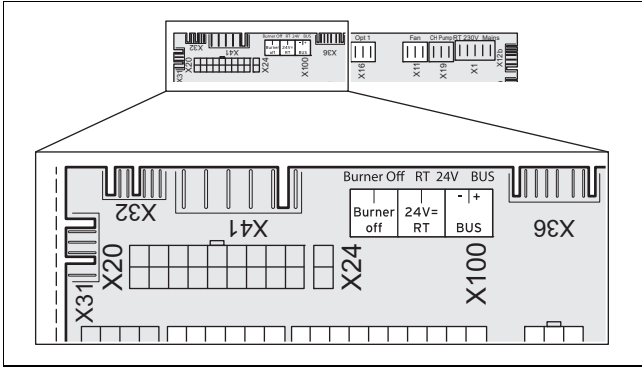
Low voltage connection area (SELV)



- General eBUS interface for controls
- 24 V thermostat
- Limit thermostat

Slot	Item	Function
	X100	<p>Caution. Risk of material damage caused by incorrect installation. Mains voltage at incorrect terminals and plug terminals may destroy the electronics.</p> <ul style="list-style-type: none"> ▶ Do not connect the mains voltage to the eBUS terminals (+/-) or to the other terminals at X100. ▶ Connect mains voltage only to the terminals that are marked for this.
	X100	<p>Bus connection control Vaillant control with eBUS communication can be connected to this slot.</p> <p>Note When using the eBUS, the bridge at the 24 V RT plug must be inserted.</p>
	X100	<p>24 V DC room thermostat Prerequisite: You are not using an eBUS control and the existing bridge is removed.</p>
	X100	<p>Burner off / limit thermostat Separate protective thermostat contact, independently of the eBUS and 24 V RT. Use when protecting against overheating for underfloor heating and/or low-temperature systems. Prerequisite: Remove the bridge.</p>

Additional connection options

Communication unit (gateway module)

- Interface (Customer Interface Module)

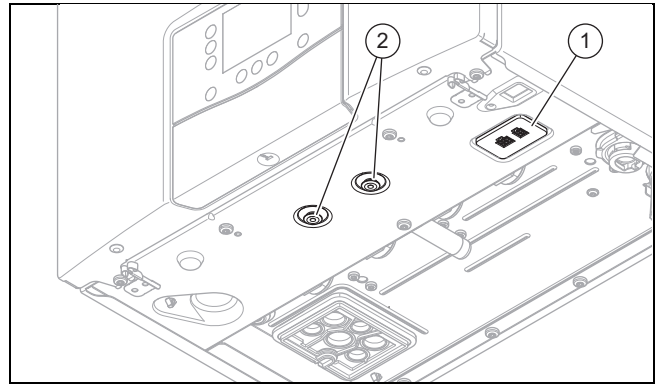

The interface (1) and the bracket (2) are located below the product. A control module can be installed and connected here. The slot includes the power supply and the eBUS communication for the gateway.

Signal connection for cylinder charging

- Cylinder thermostat (switching contact: On/off) (VU only)
- Cylinder temperature sensor (measurement of the cylinder temperature) (VU only)

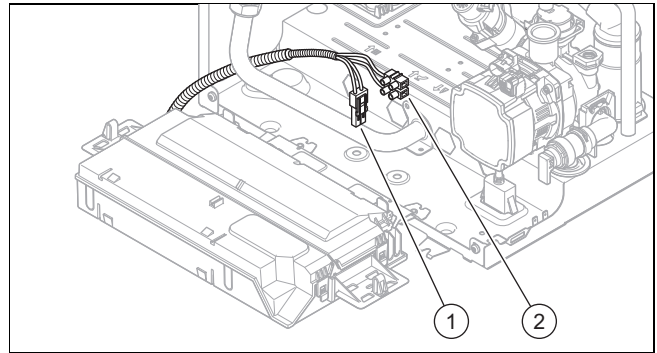

The screw connection for the switching contact (thermostat) (2) is not located on the PCB, but rather on the wiring harness on the bottom left in the product.

The plug-in connection for connecting a Vaillant cylinder temperature sensor (1) is not located on the PCB, but rather on the wiring harness on the bottom left in the product.

7.10.8 Control systems

7.10.8.1 Room control (connection)

The product can be combined with various room controls.

7.10.8.1.1 eBUS room controls

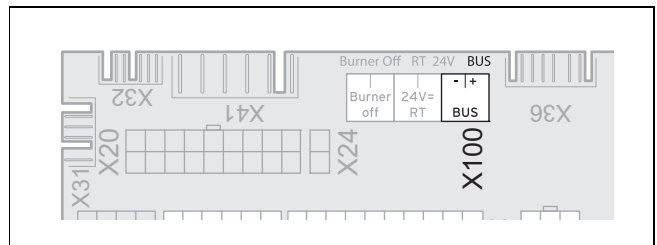

Room controls which use eBUS are connected to this interface. The interface supplies the control with electricity and is also used for signal communication.

7.10.8.1.2 Traditional room controls

Option 1: 230 V room thermostat

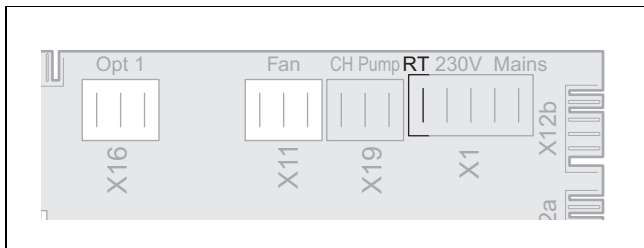

A 230 V room thermostat can be connected to this single-pole interface. Only the phase switched by the thermostat is connected. The room thermostat must be given a separate external 230 V power supply.

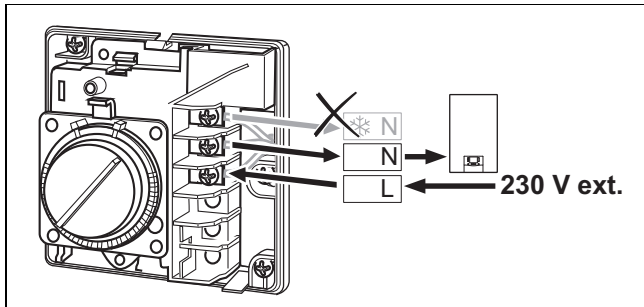

Option 2: 24 V room thermostat

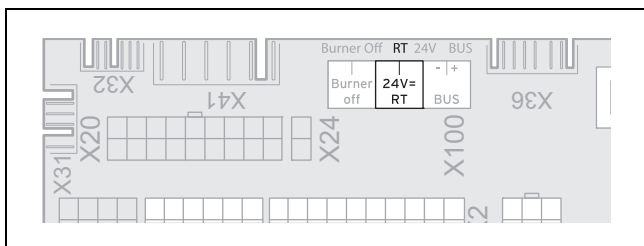

A 24 V room thermostat is connected to this interface and used to transmit the switching signal.

7.10.8.1.3 Smart room controls

Smart room controls are available when an eBUS room control and a suitable Vaillant gateway are present. The room control can be set and operated using the Vaillant app. For connection, follow the instructions in the enclosed installation instructions.

7.10.8.2 Weather-compensated control

A room control responds only indirectly to the weather conditions. On the other hand, a weather-compensated control responds directly to the weather conditions. Using an outdoor temperature sensor, the heat generator is operated depending on the outdoor temperature according to requirements.

Weather-compensated controls are eBUS controls. The outdoor temperature sensor is also connected to the PCB using a connection plug. For connection, follow the instructions in the enclosed installation instructions.

A weather-compensated eBUS control can also be intelligently set and operated in conjunction with a Vaillant gateway and the relevant Vaillant app.

7.10.8.3 Control modules

The heat generator can be combined with various control modules. Control modules are necessary if the installation comprises an external 3-port valve, buffer cylinder, etc. For installation and operation, follow the instructions in the enclosed installation and operating instructions.

7.10.8.4 myVAILLANT Connect (VR 940f) communication unit (Gateway)

A gateway enables remote communication between the user and heat generator. The gateway can be connected to this product via a special external interface.

Power supply and eBUS communication take place directly via this interface. After installation, there is the option to set and operate the control using the Vaillant app. Certain models can also be combined with other smart home solutions.

For installation, see the communication unit's installation instructions.

7.10.8.5 sensoROOM pure (VRT 50/2)

The **sensoROOM pure (VRT 50/2)** is an eBUS room control. If this control is combined with this heat generator, it is possible to configure time periods using the control display; to do so, see the heat generator's operating instructions.



Note

If a **sensoROOM pure (VRT 50/2)** is connected, the flow temperature must be set on the room temperature control and, if required, the heating mode must also be switched off there.

7.11 Installing the front casing

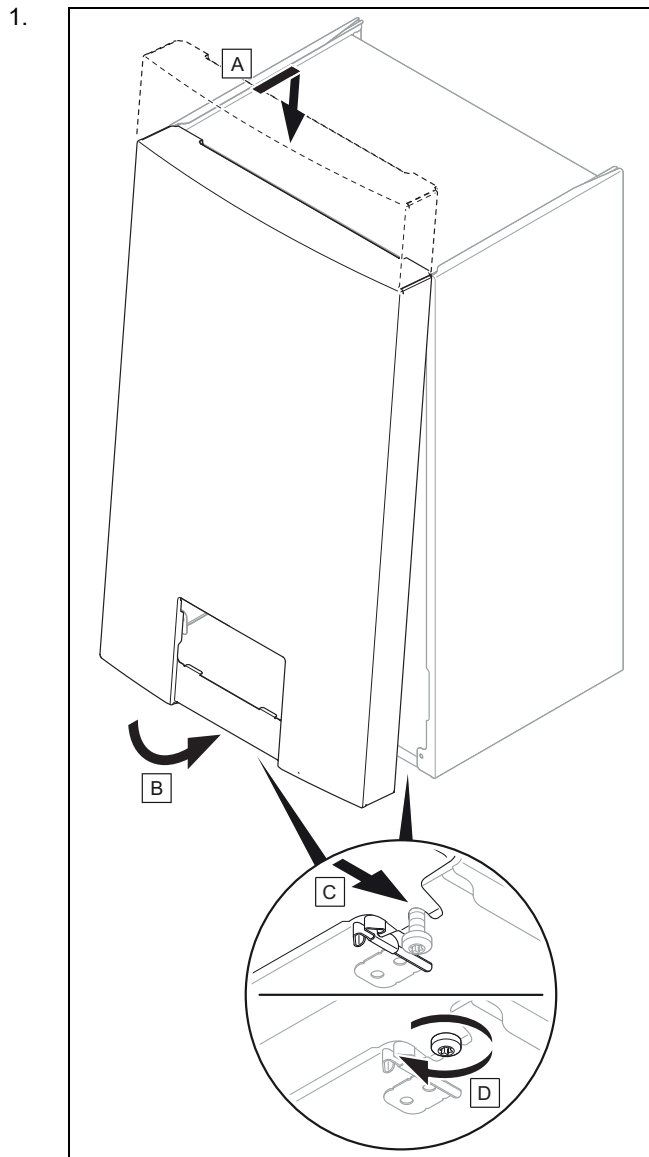

2. Tighten the two screws on the left and right on the underside of the product.



8 Operation

8.1 Operating concept

The operating concept, the operation of the product and the read-out and setting options in the end user level are described in the operating instructions.

An overview of the read-out and setting options for the installer level is included in the "Installer level" table in the appendix.



8.2 Calling up the installer level

1. Navigate to **MENU** → **SETTINGS** → **Installer level** and confirm by pressing .
2. Set the code for the installer level and confirm by pressing .
 - Code for Installer level: 17

8.2.1 Exiting the installer level

- ▶ Press .
- ◀ The basic display is shown.



8.3 Calling up/setting diagnostics codes

1. Call up the installer level. (→ Section 8.2)
2. Navigate to the **Diagnostics codes** menu item.
3. Use the scrollbar to select the required diagnostics code.
4. Confirm by pressing .
5. Use the scrollbar to select the required value for the diagnostics code.
Diagnostics codes (→ Appendix D)
6. Confirm by pressing .
7. If required, repeat work steps 2 to 6 to set additional diagnostics codes.

8.3.1 Exiting the diagnostics codes

- ▶ Press .
- ◀ The basic display is shown.



8.4 Running a check programme

1. Call up the installer level. (→ Section 8.2)
2. Navigate to the **Test modes** → **Check programmes** menu item.
3. Use the scrollbar to select the required check programme.
Check programmes (→ Appendix G)
4. Confirm by pressing .
 - ◀ The check programme starts and runs through checks.
 - ◀ If you have selected check programme **P.001**, set the desired load and then confirm by pressing .
5. While the check programme is running, press , if required, to display the **Data overview**.
6. If required, select another check programme.

8.4.1 Exiting a check programme

- ▶ Press .
- ◀ The basic display is shown.

8.5 Carrying out the actuator test

1. Call up the installer level. (→ Section 8.2)
2. Navigate to the **Test modes** → **Actuator test** menu item.
3. Use the scrollbar to select the required actuator test. Actuator test (→ Appendix H)
4. Confirm by pressing .
 - ◁ The actuator test starts and runs through.
5. While the actuator test is running, press , if required, to display the following: **Data overview**.
6. If required, select another actuator test.

8.5.1 Exiting the actuator test

- ▶ Press .
 - ◁ The basic display is shown.

8.6 Calling up the data overview

1. Call up the installer level. (→ Section 8.2)
2. Navigate to the **Data overview** menu item.
 - ◁ The current operating mode is shown in the display.

8.7 Calling up status codes

- ▶ Navigate to **MENU** → **INFORMATION** → **Status code**. Status codes (→ Appendix E)
 - ◁ The current operating mode (status code) is shown on the display.





8.7.1 Exiting the status codes

- ▶ Press .
 - ◁ The basic display is shown.

8.8 Exiting the menu level

- ▶ Press .
 - ◁ The basic display is shown.

8.9 Running the chimney sweep mode (combustion analysis)

1. Press .
2. Press  or navigate to **MENU** → **SETTINGS** → **Chimney sweep mode**.
3. To carry out the combustion analysis, select one of the following heat loads:
 - **Adjustable heat load**
 - **Max. DHW heat input**
 - **Min. heat input**
4. Confirm by pressing .
 - ◁ If you have selected **Adjustable heat load**, set the desired heat load and confirm by pressing .
 - ◁ If status code **S.093** is displayed, calibration is being carried out.
 - ◁ If status code **S.059** is displayed, the minimum flow of heating water for the selected heat load has not been reached. Increase the flow in the heating system, e.g. by opening additional radiator valves.

5. Only start a measurement once the product enables the measurement. The measurement is enabled when the status switches from **S.093** to **S.004**, **S.014** or **S.024**. Do not carry out any measurements if **S.093** is displayed.





Note

The chimney sweep mode runs for 15 minutes. It can be cancelled at any time by pressing .

6. If required, press  to display the **Data overview**.

8.10 Switching on the button lock (Advanced Key Lock)

You can use the button lock to protect the entire control panel against unauthorised manipulation. When the button lock is switched on, the request to enter the code for the installer level appears after you press . The button lock can only be released again by entering the code and switching off the function. Once you enter the code, a time period of four minutes starts and you can implement settings within this time period without releasing the button lock.

If you press  after entering the code, the chimney sweep mode runs for 15 minutes. The button lock only becomes active again after this.

- ▶ Call up the installer level. (→ Section 8.2)
- ▶ Navigate to the **Diagnostics codes** menu item.
- ▶ Use the scrollbar to select diagnostics code **D.168**.
- ▶ Activate or deactivate the button lock.
- ▶ Confirm by pressing .

9 Start-up

During initial start-up, the operating data may initially deviate from the specified nominal data.

During initial start-up, the fan is actuated at maximum speed for checking for a potential flue gas blockage. The burner operation is then blocked for two minutes. This test is repeated automatically when the unit is switched on again, provided that the unit has not been in burner mode for 10 minutes.

9.1 Pre-Commissioning checklist

Check this list before power on and first commissioning.

Number	Check	Yes (✓)
Electrical		
1	Check the wiring of controls is correct (Vaillant eBUS) or third party controls	
2	Correct cable size and type have been used	
3	Correct fuse rating (< 3 amp) is protecting the system	
4	Correct cable entry points have been used for all external wiring	

Number	Check	Yes (✓)
5	Isolation is via a double pole switched fused spur or 3 pin fused plug in unswitched shuttered socket	
Flue system		
6	The flue type and length conforms with the boiler model type and maximum lengths allowable (including bend restrictions)	
7	All flue joints correctly connected and flue lengths correctly supported	
Condensate		
8	Condensate termination point checked and correctly insulated if external	
9	Condensate trap filled and re-sealed in correct position	
Gas		
10	Gas Tightness test completed	
11	Standing gas pressure checked – and turned on if safe	
Water		
12	Water Heating circuits are prepared for first cold fill	
13	Mains water treatment installed (Combi boilers)	
14	Heating system has been cleansed thoroughly and suitably treated	
15	Heating system filter installed and valves open	

- ▶ Follow the installation wizard instructions that appear on the interface, follow each instruction in turn until complete.

Tips/hints for the new ecoTEC/1-5

Electronic heat engine

- You don't need any tools, just use the relevant diagnostic points, e.g. **D.000**, **D.085**, **D.146 - D.147**, **D.156 - D.157**, **D.164**.

Intelligent hydraulics

- Yes, there is a bypass, but it has a different task. Use the properties of the pump with **D.170** and **D.171** bis **D.175**.

User interface

- Use the new possibilities of the interface, e.g. for the exhaust gas analysis use the new chimney sweep function.

9.2 Carrying out the initial start-up

Initial start-up must be carried out by a customer service technician or an authorised competent person using the Benchmark Checklist. The Benchmark Checklist in the appendix (→ Appendix M) of the installation instructions must be filled in and stored carefully along with the unit's documentation.

- ▶ Carry out the start-up procedure using the Benchmark Checklist in the appendix.
- ▶ Fill out and sign the Benchmark Checklist.

9.3 Checking and treating the heating water/filling and supplementary water



Caution.

Risk of material damage due to poor-quality heating water

- ▶ Ensure that the heating water is of sufficient quality.

- ▶ Before filling or topping up the installation, check the quality of the heating water.

Checking the quality of the heating water

- ▶ Remove a little water from the heating circuit.
- ▶ Check the appearance of the heating water.
- ▶ If you ascertain that it contains sedimentary materials, you must desludge the installation.
- ▶ Use a magnetic rod to check whether it contains magnetite (iron oxide).
- ▶ If you ascertain that it contains magnetite, clean the installation and apply suitable corrosion-inhibition measures (e.g. fit a magnetite separator).
- ▶ Check the pH value of the removed water at 25 °C.
- ▶ If the value is below 8.2 or above 10.0, clean the installation and treat the heating water.
- ▶ Ensure that oxygen cannot get into the heating water.

Checking the filling and supplementary water

- ▶ Before filling the installation, measure the hardness of the filling and supplementary water.

Treating the filling and supplementary water

- ▶ Observe all applicable national regulations and technical rules when treating the filling and supplementary water.

Provided the national regulations and technical rules do not stipulate more stringent requirements, the following applies:

You must treat the filling and supplementary water in the following cases

- If the entire filling and supplementary water quantity during the operating life of the system exceeds three times the nominal volume of the heating installation, or
- If the guideline values listed in the following table are not met, or
- If the pH value of the heating water is less than 8.2 or more than 10.0.

Total heating output	Water hardness at specific system volume ¹⁾					
	≤ 20 l/kW		> 20 l/kW ≤ 40 l/kW		> 40 /kW	
kW	ppm CaCO ₃	mol/m ³	ppm CaCO ₃	mol/m ³	ppm CaCO ₃	mol/m ³
< 50	< 300	< 3	150	≤ 1.5	5	0.05
> 50 to ≤ 200	200	< 2	150	≤ 1.5	5	0.05
> 200 to ≤ 600	150	< 1.5	5	0.05	5	0.05
> 600	5	0.05	5	0.05	5	0.05

1) Nominal capacity in litres/heat output; in the case of multi-boiler systems, the smallest single heat output is to be used.



Caution.

Risk of material damage if the heating water is treated with unsuitable additives.

Unsuitable additives may cause changes in the components, noises in heating mode and possibly subsequent damage.

- ▶ Do not use any unsuitable antifreeze and corrosion inhibitors, biocides or sealants.

No incompatibility with our products has been detected to date with proper use of the following additives.

- ▶ When using additives, follow the manufacturer's instructions without exception.

We accept no liability for the compatibility of any additive or its effectiveness in the rest of the heating system.

Additives for cleaning measures (subsequent flushing required)

- Adey MC3+
- Adey MC5
- Fernox F3
- Sentinel X 300
- Sentinel X 400

Additives intended to remain permanently in the installation

- Adey MC1+
- Fernox F1
- Fernox F2
- Sentinel X 100
- Sentinel X 200

Additives for frost protection intended to remain permanently in the installation

- Adey MC ZERO
 - Fernox Antifreeze Alpha 11
 - Sentinel X 500
- ▶ If you have used the above-mentioned additives, inform the end user about the measures that are required.
 - ▶ Inform the end user about the measures required for frost protection.

9.4 Deactivating standby mode



Note

If the product is connected via a fixed connection, the product is switched on as soon as the power supply is established.

- ▶ Press the on/off button on the display.
 - ◀ The display shows the basic display.

9.5 Running through the installation assistant

The installation assistant is launched when the product is switched on for the first time.

After starting the installation assistant, all of the product's requirements are blocked. This status remains until the installation assistant is completed or cancelled.

- ▶ Close the gas stopcock before running the installation assistant.
- ▶ Ensure that the gas stopcock remains closed until the installation assistant has finished running.
- ▶ Once the installation assistant has ended, open the gas stopcock and switch on the heat demand.

You can restart the installation assistant at any time.

9.5.1 Setting the language, date and time

- ▶ Set the required language, date and time, and confirm.

9.5.2 Filling the installation

Filling mode (check programme **P.008**) is activated automatically in the installation assistant for as long as the filling mode appears on the display.

- ▶ Start the filling programme and fill the heating installation with heating water. Observe the specifications for treating the heating water.
- ▶ Wait until the programme has ended.

9.5.3 Setting the hydraulic operating mode



Note

Different hydraulic operating modes are available depending on the product variant.

- ▶ Set the hydraulic operating mode and confirm. You can adjust the operating mode again at a later point via the diagnostics codes. (→ Section 10.3.5)
- ▶ Set the available pressure.

9.5.4 Setting the gas type

1. Set the gas type that is available on-site and with which you want to operate the product, and confirm.

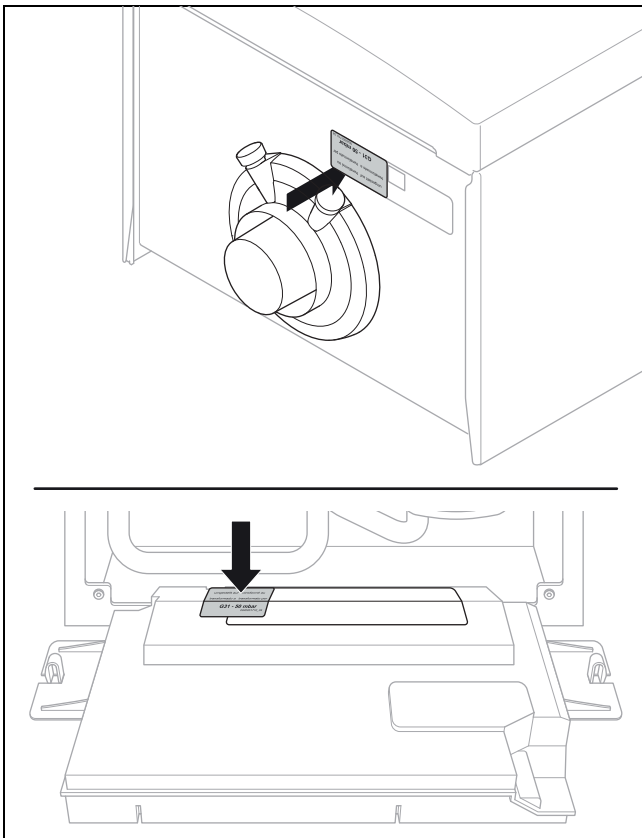

- After converting the gas type, the two supplied stickers for the new gas type must be affixed onto the large data plate (electronics box) and onto the small data plate (on the top of the product).

9.5.5 Setting the air/flue pipe type

- ▶ Set the correct air/flue pipe type with which the product was installed, and confirm.

9.5.6 Contact details

- ▶ If required, store your telephone number and your company name in the **Appliance config.** (max. 16 digits/no blank spaces). The end user can view the telephone number.

9.5.7 Restarting the installation assistant

- Navigate to **MENU** → **SETTINGS** → **Installer level** → **Installation assistant**.
- Confirm by pressing .

9.6 Check programmes and actuator tests

MENU → **SETTINGS** → **Installer level** → **Test modes**

In addition to the installation assistant, you can also call up the following functions for start-up, maintenance and troubleshooting:

Check programmes (→ Appendix G)

Actuator test (→ Appendix H)

9.7 Guaranteeing the system pressure

If the heating installation covers multiple storeys, higher values than the permissible operating filling pressure may be necessary for the filling pressure in order to prevent air from getting into the heating installation.

This static height is the height difference in metres between the heat generator and the highest heating area for a cellar installation or the lowest heating area for a rooftop control system.

- Permissible operating filling pressure: 0.1 to 0.2 MPa (1.0 to 2.0 bar)

The operating filling pressure must be increased by 0.01 MPa (0.1 bar) for every metre of the determined static height. The filling must take place via the intake side of the heating pump, usually the return.

Once the maximum filling pressure is reached, the product signals the excess pressure using a flashing value on the display.

- Maximum operating filling pressure: ≤ 0.25 MPa (≤ 2.50 bar)

Once the filling pressure reaches the minimum filling pressure, the product signals that the pressure is low using a flashing value on the display.

- Minimum operating filling pressure: < 0.08 MPa (< 0.80 bar)

Once the filling pressure reaches the operating limit filling pressure, the product shuts down and the display shows fault code **F.022**.

- Operating limit filling pressure: ≤ 0.03 MPa (≤ 0.30 bar)

- ▶ When you fill or top up the heating water, start the purge programme (→ Section 9.10).

9.8 Flushing the heating installation for the first time ("cold")



Note

The complete heating system must be flushed at least twice: Once with cold water and once with hot water in accordance with the following instructions.

- Check whether all thermostatic radiator valves and both service valves on the product are open.
- Connect a hose to the drain valve that is located at the lowest position in the heating system.
- Open the radiator valves and the drain valves so that the water can drain quickly. Start at the next point in the installation and open the purging valves on the radiators so that the contaminated water can completely drain.
- Close the draining cocks.
- Refill the heating system with water.
- Check that the expansion relief valve of the heating system is functioning correctly by turning the handle on the valve.
- Check the pressure in the heating system and top up with water if necessary.
- Close the filling valve and the cold water tap.

9.9 Filling the heating installation

1. Start check programme **P.008**. (→ Section 8.4)
 - ◁ The prioritising diverter valve moves to the mid-position, the pumps do not run and the product does not switch to heating mode.
2. Observe the information on treating heating water. (→ Section 9.3)

Validity: Product with integrated hot water generation

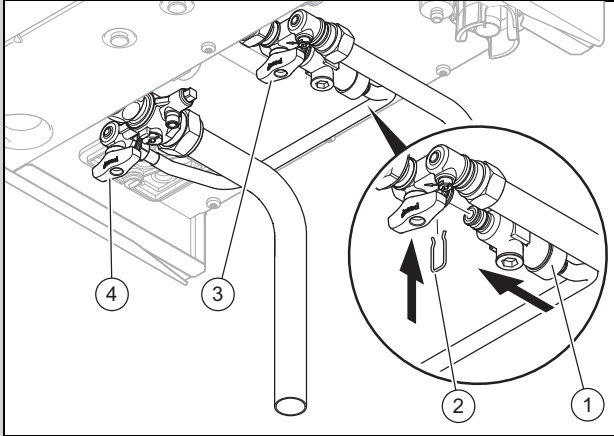

- ▶ Open all radiator valves (thermostatic valves) of the heating installation.
- ▶ Fit the double non-return valve (1) of the filling line to the cold-water isolation valve and secure the valve with the spring clip (2).
- ▶ To fill, first open the isolation valve (3).
- ▶ Open the isolation valve (4) so that the water flows into the heating system. Fill the heating system.
- ▶ Purge the lowest radiator until water flows out of the purging valve without bubbles.
- ▶ Purge all other radiators until the entire heating system has been filled with water.
- ▶ Close all purging valves.
- ▶ Monitor the rising filling pressure in the heating installation.
- ▶ Fill with water until the required filling pressure is reached.
- ▶ After filling, close isolation valve (4) first and then isolation valve (3). Disconnect the filling device by removing the double non-return valve from the cold-water isolation valve.



Note

Both isolation valves must be closed while the heating system is operating and the filling line must be removed from the double non-return valve again.

Validity: Product with connected domestic hot water cylinder

- ▶ Connect the filling/draining cock in the heating installation to a heating water supply, if possible with the cold water tap, in accordance with the relevant standards.
- ▶ Open the heating water supply.
- ▶ Open all radiator valves (thermostatic valves) of the heating installation.
- ▶ If necessary, check that both service valves on the product are open.
- ▶ Slowly open the filling/draining cock so that the water flows into the heating system.

- ▶ Purge the lowest radiator until water flows out of the purging valve without bubbles.
- ▶ Purge all other radiators until the entire heating system has been filled with water.
- ▶ Close all purging valves.
- ▶ Monitor the rising filling pressure in the heating installation.
- ▶ Fill with water until the required filling pressure is reached.
- ▶ Close the filling/draining cock and the cold water tap.

9.10 Purging the heating installation

1. When you top up the heating water, start check programme **P.000**. (→ Section 8.4) If fault code **F.022** was present for longer than 30 seconds, it is sufficient to start the purge programme in order to reset the fault code. It is not necessary to press the reset button.
 - ◁ The product does not start up, the internal pump operates intermittently and automatically purges the heating circuit or the domestic hot water circuit.
 - ◁ The display shows the filling pressure of the heating installation.
2. Ensure that the filling pressure of the heating installation does not fall below the minimum operating filling pressure.
 - $\geq 0.08 \text{ MPa}$ ($\geq 0.80 \text{ bar}$)
3. Check whether the filling pressure of the heating installation is at least 0.02 MPa (0.2 bar) above the diaphragm expansion vessel's counter-pressure ($P_{\text{system}} \geq P_{\text{diaphragm expansion vessel}} + 0.02 \text{ MPa}$ (0.2 bar)).

Result:
Filling pressure of the heating installation is too low

 - ▶ Fill the heating installation. (→ Section 9.9)
4. If there is still too much air in the heating installation at the end of check programme **P.000**, restart the check programme.

9.11 Filling and purging the domestic hot water system

Validity: Product with integrated hot water generation

1. Open the cold-water isolation valve on the product.
2. Fill the domestic hot water system by opening all the domestic hot water draw-off valves until water escapes.

9.12 Filling the condensate siphon

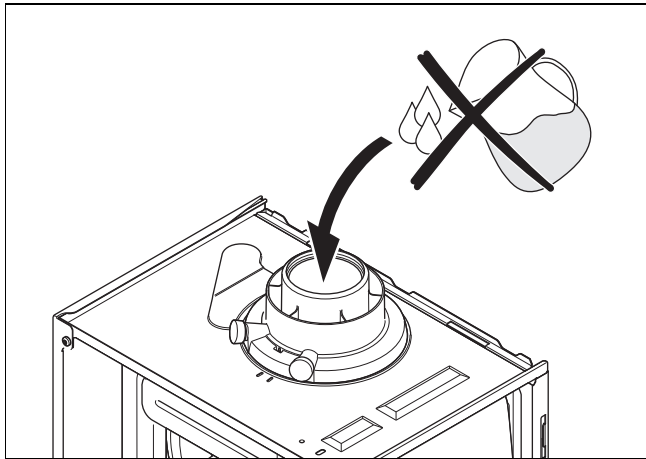

1. Never fill the condensate siphon via the air/flue connector.

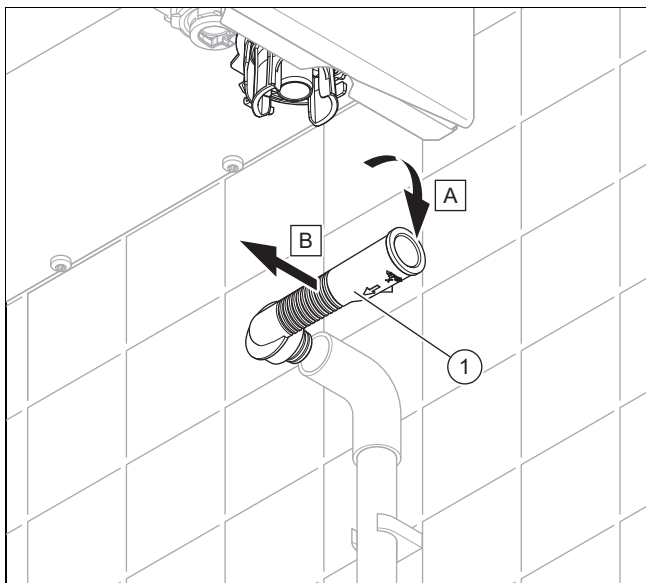

2. Remove the condensate adapter (1) from the lower section of the siphon and from the condensate discharge pipe.

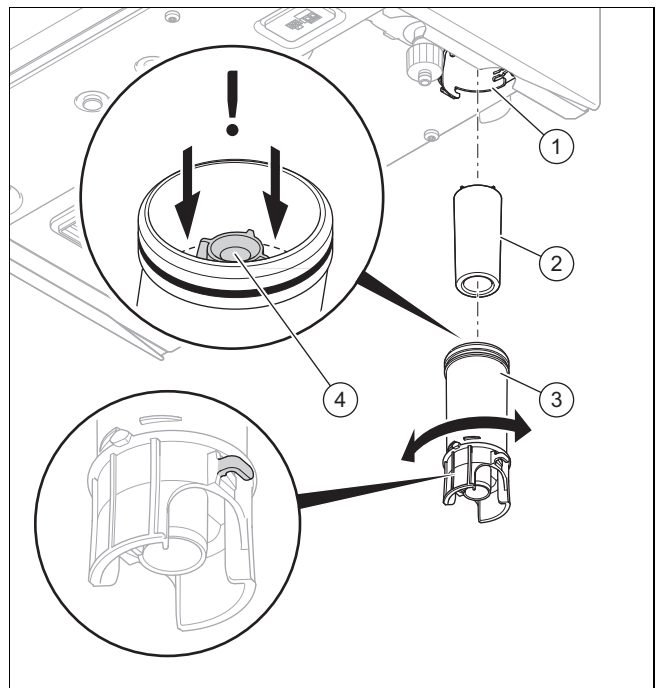

3. Loosen the lower section of the siphon (3) by turning the upper section of the siphon (1) by a quarter turn and pull it downwards and out.
4. Remove the float (2).
5. Fill the lower section with water up to a filling level 10 mm below the condensate discharge (4).
6. Re-insert the float.
7. Push the lower section of the siphon as far as it will go into the upper section of the siphon and rotate it clockwise until you hear it click into place.
8. Reconnect the condensate adapter to the lower section of the siphon and to the condensate discharge pipe.

9.13 Checking the gas settings

As part of the start-up, the following technical tests must be carried out under the conditions on-site in order to enable the product for operation.

- Check that the product complies with the local gas group: Correct product for the available gas group?
- Recirculation check: Is the air/flue system ready to use?
- Gas flow pressure check: Is the gas supply ready to use?
- O₂ content check: Is the combustion correct?
- Gas flow rate check: Sufficient gas flow for the operation?

By checking the heat cell, the other functional areas of the product are also automatically checked, e.g. the hydraulics, electronics, etc.

9.13.1 Checking the factory-set gas setting

- ▶ Check the information about the gas type indicated on the data plate and compare this with the gas type available at the installation site.

Result 1:

The product design is not compatible with the local gas group.

- ▶ Do not start up the product.
- ▶ Contact customer service.

Result 2:

The product design is compatible with the local gas group.

- ▶ Check the gas connection pressure/gas flow pressure. (→ Section 9.13.3)
- ▶ Check the O₂ content. (→ Section 9.13.4)

9.13.2 Checking the air/flue pipe/flue gas recirculation

1. Check whether the front casing (vacuum chamber) has been closed tightly.
2. Start up the product in chimney sweep mode. (→ Section 8.9)
3. Check the flue gas installation is intact in accordance with the latest gas safe technical bulletin and information supplied in the installation instructions.
4. For extended flue gas installations check for flue gas recirculation using the air analysis point.
5. Use a flue gas analyser.
6. If you discover unusual levels of either CO or CO₂ or O₂ in the supply air, search for the leak in the flue system or for signs of flue gas recirculation.
7. Eliminate the damage properly.
8. Check again whether the supply air contains any unusual levels of either CO or CO₂ or O₂.
9. If you cannot eliminate the damage, do not start up the product.
10. Seal the test openings again using the sealing caps.

9.13.3 Checking the gas connection pressure/gas flow pressure

1. Ensure that the gas inlet working pressure can be obtained with all other gas appliances in the property working.
2. Remove the front casing. (→ Section 7.10.2)
3. Temporarily decommission the product. (→ Section 14.2)
4. Hinge the electronics box downwards.

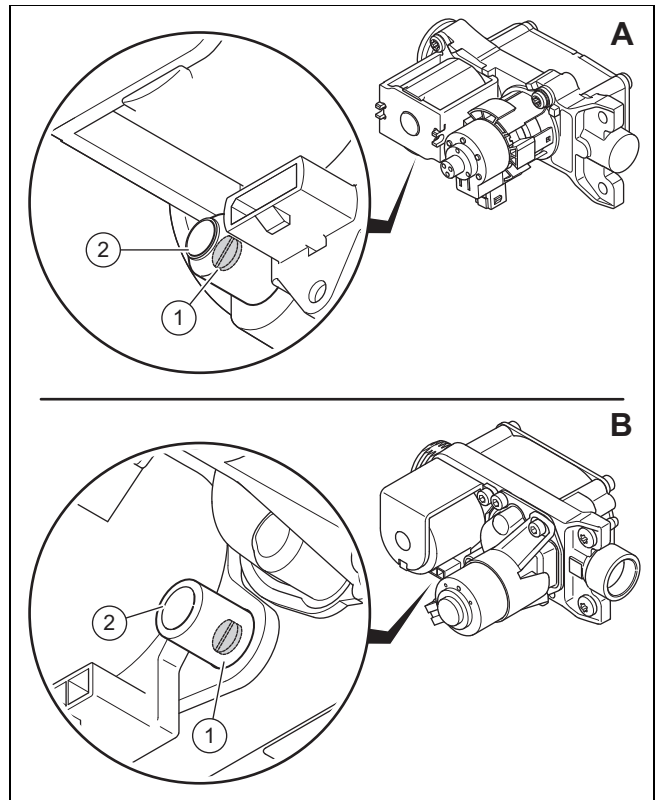

5. Undo the check screw (1).
 - Turning anti-clockwise: 2
6. Connect a manometer to the test nipple (2) for the gas valve assembly.
 - Working materials: U tube manometer
 - Working materials: Digital pressure gauge
7. Hinge the electronics box upwards.
8. Ensure that the heat is dissipated in the heating or domestic hot water system.
9. Open the gas stopcock.
10. Start up the product at maximum power in chimney sweep mode.
11. Wait until status displays **S.004**, **S.014** and **S.024** have gone out.
12. Measure the gas connection pressure/gas flow pressure against the atmospheric pressure.
13. Monitor the measured value. If the measured value remains stable within a small tolerance, note down the measured value.
14. Temporarily decommission the product. (→ Section 14.2)
15. Stop the heat demand in the heating and domestic hot water system.
16. Allow the boiler to cool down allowing pump overrun to operate for a minimum of two minutes.
17. With the boiler operating at full load check that the gas inlet working pressure at the reference test point complies with the requirements.
18. Remove the manometer.
19. Tighten the screw plug for the test nipple on the gas valve assembly. Tightening torque, see appendix.
20. If the test nipple on the gas isolation valve has been used, tighten the screw plug for the test nipple. Tightening torque, see appendix.
 - Working materials: 3 mm hex key
21. Open the gas stopcock.
22. Check all test nipples in the gas route for gas tightness.

23. Hinge the electronics box upwards.
24. Check the noted measured value against the manufacturer details.

Permissible gas flow pressure

Great Britain	Natural gas	H	1.3 to 2.3 kPa (13.0 to 23.0 mbar)
	Liquid gas	P	2.3 to 4.3 kPa (23.0 to 43.0 mbar)

Result 1:

Gas connection pressure/gas flow pressure in the permissible range

The product is ready to use.

- ▶ Install the front casing. (→ Section 7.11)
- ▶ Record the appliance gas inlet working pressure (kPa resp. mbar) in the Benchmark gas boiler commissioning checklist.

Result 2:

Gas connection pressure/gas flow pressure not in the permissible range



Caution.

Risk of material damage and operating faults caused by incorrect gas connection pressure/gas flow pressure.

If the gas connection pressure/gas flow pressure lies outside the permissible range, this can cause operating faults in and damage to the product.

- ▶ Do not make any adjustments to the product.
- ▶ Do not start up the product.

- ▶ If you are unable to eliminate the fault, contact the gas supply company.
- ▶ Temporarily decommission the product. (→ Section 14.2)
- ▶ Install the front casing. (→ Section 7.11)
- ▶ Close the gas stopcock.
- ▶ Disconnect the product from the power grid.
- ▶ You must not start up the boiler.

9.13.4 Checking the O₂ content



Note

Carry out the measurements only when the front casing is installed.



Note

During a combustion analysis it is no longer a requirement to check the CO₂ value as the CO₂ value is not required for the correct verification of combustion. A standard-compliant check is carried out via the O₂ value according to BS 7967.

The O₂ value directly reflects the oxygen supply required for complete combustion. It is still required to record all combustion parameters within the benchmark document.

1. Open the test opening at the flue gas analysis point.
2. Position the measuring probe for the flue gas analyser.
3. Start chimney sweep mode (→ Section 8.9).
4. Ensure that the heat load is correct.
 - **Max. DHW heat input** (standard selection)
 - **Adjustable heat load** (for some installations, this deviates from the standard selection)
5. Wait until the product has completed the calibration via **S.093** and the status changes to **S.004**, **S.014** oder **S.024**.
6. Record the core current of the flue gas and wait until the measured value has stabilised. Log the measured value reading.
7. Compare the measured value reading with the permissible ranges from the diagrams.

Validity: VU 10CS/1-5 (N-GB) ecoTEC plus 610 OR VU 15CS/1-5 (N-GB) ecoTEC plus 615 OR VU 20CS/1-5 (N-GB) ecoTEC plus 620 OR VUW 20/26CS/1-5 (N-GB) ecoTEC plus 826

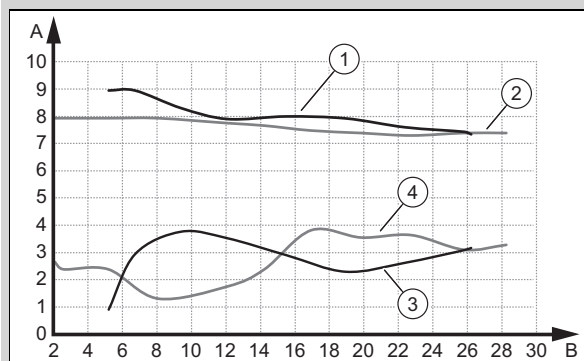

A	O ₂ content [vol%]	B	Heat input [kW]
1	Max. O ₂ content, liquefied petroleum gas	3	Min. O ₂ content, liquefied petroleum gas
2	Max. O ₂ content, natural gas	4	Min. O ₂ content, natural gas

Validity: VU 25CS/1-5 (N-GB) ecoTEC plus 625 OR VU 30CS/1-5 (N-GB) ecoTEC plus 630 OR VUW 25/32CS/1-5 (N-GB) ecoTEC plus 832 OR VUW 30/36CS/1-5 (N-GB) ecoTEC plus 836

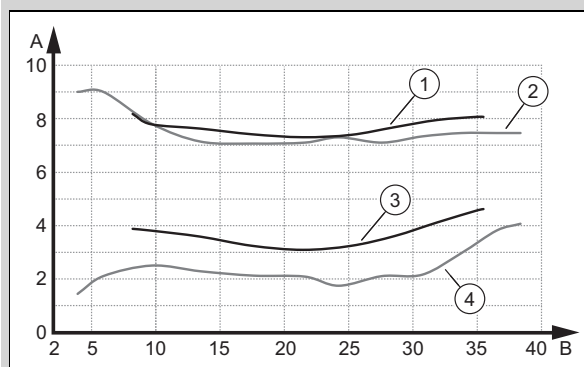

A	O ₂ content [vol%]	B	Heat input [kW]
1	Max. O ₂ content, liquefied petroleum gas	3	Min. O ₂ content, liquefied petroleum gas
2	Max. O ₂ content, natural gas	4	Min. O ₂ content, natural gas

Validity: VU 35CS/1-5 (N-GB) ecoTEC plus 635 OR VUW 30/40CS/1-5 (N-GB) ecoTEC plus 840

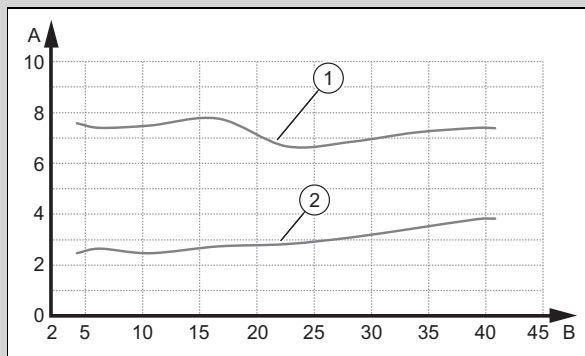

A O₂ content [vol%] B Heat input [kW]
 1 Max. O₂ content, natural gas 2 Min. O₂ content, natural gas

Result:

The value lies outside of the permitted range

- ▶ Check the total pipe length of the air/flue system; see the set-up instructions for the air/flue system.
- ▶ Check the air/flue system for recirculation and blockages. (→ Section 9.13.2)
- ▶ Measure the O₂ content at the flue gas analysis point again and log the measured value in the benchmark log in the appendix.
- ▶ If the O₂ content remains outside of the permissible range, correct the gas-air ratio via **D.158** and measure the O₂ content again at the flue gas analysis point.
- ▶ If the O₂ content remains outside of the permissible range, replace the control electrode (→ Section 13.7.14) and reset **D.158** to the factory setting.
- ▶ Measure the O₂ content at the flue gas analysis point again and log the measured value.
- ▶ If the value is still outside of the permissible range, do not start up the product and, instead, report this to customer service.

8. Remove the flue gas analyser and close the test opening at the flue gas analysis point.

9.13.5 Checking the gas flow rate

The gas flow rate has been set during production and does not require adjustment. With the front casing fitted check the gas flow rate of the boiler as follows:

- ▶ Check whether the front casing (vacuum chamber) has been closed tightly.
- ▶ Start up the product with the check programme **P.01**.
- ▶ In addition, ensure that maximum heat can be dissipated into the heating system by turning up the room thermostat.
- ▶ Wait at least 5 minutes until the boiler has reached its operating temperature.
- ▶ Ensure that all other gas appliances in the property are turned off.
- ▶ Measure the gas flow rate at the gas meter.
- ▶ Compare the measured values with the corresponding values in the table.

Q _{nw} from the data plate	H gas in m ³ /h		
	Nom.	+5%	-10%
15.3	1.62	1.70	1.46
18.4	1.95	2.05	1.76
24.7	2.61	2.74	2.35
25.7	2.72	2.86	2.45
28.6	3.03	3.18	2.73
30.6	3.24	3.40	2.92
35.7	3.78	3.97	3.40

Condition: Gas flow rate not in the permissible range

- ▶ Check the compliance with the local gas group. (→ Section 9.13.1)
- ▶ Check the gas supply and monitor the flow pressure during the test operation. (→ Section 9.13.3)
- ▶ Check all of the piping and ensure that the gas flow rates are correct.
- ▶ Only put the product into operation once the gas flow rates have been corrected.

Condition: Gas flow rate in the permissible range

- ▶ End the check programme **P.01**.
- ▶ Allow the boiler to cool down by allowing pump overrun to operate for a minimum of 2 minutes.
- ▶ Record the boiler maximum gas flow rate onto the Benchmark Checklist.

9.14 Thoroughly flushing the heating installation ("hot")

1. Operate the appliance until the boiler and the heating system are up to temperature.
2. Check the heating system for leaks.
3. Connect a hose to the drain valve located at the lowest position of the heating system.
4. Shut off the boiler, open the drain valve and all purge valves on the radiators and allow the water to flow out of the heating system and the boiler quickly and fully.
5. Close the drain valve.
6. Fill the heating system again with water as described in Filling the heating installation (→ Section 9.9) and Purging the heating installation (→ Section 9.10).
7. Re-fill the system until the system design pressure of 0,1 MPa (1,0 bar) is attained.



Note

The actual reading on the digital pressure gauge should ideally be 0,05 MPa (0,5 bar) plus an additional pressure corresponding to the highest point of the system above the base of the boiler – 10 m head equals an additional 1 bar reading on the pressure gauge. The minimum pressure should not be less than 0,1 MPa (1 bar) in any installation. If the system is to be treated with an inhibitor it should be applied at this stage in accordance with the manufacturer's instructions.

9.15 Checking the heating mode

1. Ensure that there is a heat demand.
2. Navigate to **MENU** → **SETTINGS** → **Installer level** → **Data overview**.
 - ◁ If the product is working correctly, the display shows **S.004**.

9.16 Checking the domestic hot water generation

1. Make sure that there is a domestic hot water demand.

Validity: Product with connected domestic hot water cylinder

- ▶ Navigate to **MENU** → **SETTINGS** → **Installer level** → **Data overview**.
 - ◁ If the domestic hot water cylinder is charged correctly, **S.024** appears in the display.
 - ◁ If the cylinder has a temperature sensor, check the temperature in the cylinder **DHW cylinder outlet temp**.

Validity: Product with integrated hot water generation

- ▶ Navigate to **MENU** → **SETTINGS** → **Installer level** → **Data overview**.
 - ◁ If domestic hot water is drawn off at a water tap, **S.014** appears in the display.
 - ◁ Check the domestic hot water temperature **Actual DHW temperature**

Condition: Control connected

- ▶ Set the target temperature for the connected domestic hot water cylinder on the control (→ Operating and installation instructions for the control).
 - ◁ The boiler adopts the target temperature which is set on the control.

9.17 Checking leak-tightness

- ▶ Check the gas-carrying components, the heating circuit and the domestic hot water circuit for tightness.
- ▶ Check that the air/flue pipe has been installed correctly.
- ▶ Check whether the front panel is fitted.

9.18 Converting the product to a different gas type



Note

For initial start-up, the desired gas type is defined when carrying out the installation assistant. If liquefied petroleum gas is selected, the supplied sticker must be affixed.



Note

If the gas type is converted at a later date, a conversion set is required (control electrode replacement).

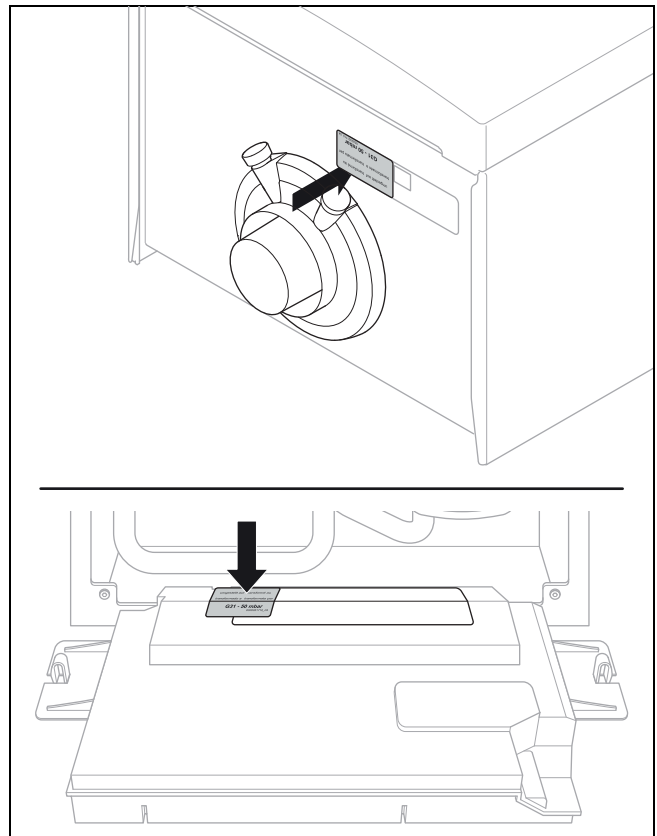

Condition: Converting the gas type at a later time

- ▶ Follow the instructions in the manual that is included with the conversion set.

10 Adapting the unit to the installation

10.1 Setting parameters

- ▶ Navigate to the **Appliance config.** menu and set the most important system parameters.
- ▶ Navigate to the **Start inst. assistant** menu and restart the installation assistant.
- ▶ Navigate to the **Diagnostics menu** menu and set additional system parameters.

Diagnostics codes (→ Appendix D)

10.2 Activating an additional component for the multi-functional module

Condition: Components connected to relay 1

- ▶ Select the parameter **D.027** to assign a function to relay 1. (→ Section 8.3)

Condition: Components connected to relay 2

- ▶ Select the parameter **D.028** to assign a function to relay 2. (→ Section 8.3)

10.3 Adapting the heating mode settings

10.3.1 Heat input

During operation, the heat input is continuously adjusted to the required heat output for the heating system.

10.3.1.1 Minimum heat input

You can use **D.085** to raise the lowest heat input in the range between the minimum value and the limit value for the ignition output that is technically required. The heat cell modulates up to the set value and the modulation range is restricted.

The cycling mode is made more likely by raising the lower modulation limit.

This setting applies for heating and domestic hot water mode.

10.3.1.2 Setting the maximum heat input

The maximum heat input can be adjusted to the installation's determined output requirement via **D.000**.

If the **Auto** setting is activated in parameter **D.000**, the product automatically adjusts the maximum heat input to the installation's current requirements.

10.3.2 Flow temperature

10.3.2.1 Limiting the flow temperature

The maximum target value for the flow temperature in heating mode can be limited. The product will not reach a higher temperature level in the heating mode.

- ▶ Call up the installer level. (→ Section 8.2)
- ▶ Set diagnostics code **D.071** to the individual maximum value.

10.3.2.2 Setting the flow temperature

A target value for the flow temperature in heating mode can only be set via the control panel if no system control is connected to the product. This is not usually the case.

The flow temperature is the temperature at which the heating water leaves the heat generator (e.g. 65° C).

- ▶ From the basic display, press .
 - ◀ The flow temperature that has already been set is shown in the display.

10.3.2.3 Setting the desired temperature

→ System control operating and installation instructions

The system control can be used to set the desired temperature.

The desired temperature is the temperature that is desired for the living room (e.g. 21 °C).



Note

The selection of the desired temperature does not affect the flow temperature.

10.3.3 Setting the operating mode and overrun for the heating pump

With regard to the heat supply for the heating system, it is important to detect the heat saturation and the heat demand for the heating system. There are two setting options for this:

- Pump overrun
- Pump mode

After the burner stops, the pump overrun can be defined in real time via diagnostics code **D.001**.

The pump mode can be selected via diagnostics code **D.018**. The pump mode does not affect the pump control strategy. There are two modes:

- Permanent: The internal heating pump runs continuously in the active heating time period.
- ECO: The pump runs intermittently following burner operation and pump overrun in order to detect a potential heat demand (5 mins on/25 mins off)



Note

A heat demand is detected from the negative target-to-actual flow temperature deviation for heating mode.

10.3.4 Burner anti-cycling time

To prevent frequent switching on and off of the burner and thus prevent energy losses, an electronic restart lockout is activated for a specific period each time the burner is switched off. The burner anti-cycling time is only active for the heating mode. Hot water handling during a burner anti-cycling time does not affect the time function element (default setting: 20 mins).

10.3.4.1 Setting the burner anti-cycling time

Diagnostics code **D.002** can be used to adjust the burner anti-cycling time for a potential cycle optimisation in heating mode. If no heating mode heat demand is detected in the direct pump overrun, no burner start takes place in the active burner anti-cycling time (**D.067**).

The effective heating mode burner anti-cycling time is determined from the maximum possible target flow temperature (**D.071**), the current target flow temperature and the setting level under **D.002**.

- ▶ Set diagnostics code **D.002**. (→ Section 8.3)
- ▶ Exit the diagnostics codes. (→ Section 8.3.1)
- ▶ Exit the installer level. (→ Section 8.2.1)

Effective burner anti-cycling times **D.002** at max. target flow temperature 75 °C

T _{Flow} (target) [°C]	Set maximum burner anti-cycling time [min]						
	2	5	10	15	20	25	30
30	2.0	4.5	8.5	12.6	16.7	20.8	24.9
35	2.0	4.2	7.8	11.5	15.1	18.7	22.4
40	2.0	3.9	7.1	10.3	13.5	16.6	19.8
45	2.0	3.6	6.4	9.1	11.8	14.5	17.3
50	2.0	3.4	5.6	7.9	10.2	12.5	14.7
55	2.0	3.1	4.9	6.7	8.5	10.4	12.2
60	2.0	2.8	4.2	5.5	6.9	8.3	9.6
65	2.0	2.5	3.5	4.4	5.3	6.2	7.1
70	2.0	2.3	2.7	3.2	3.6	4.1	4.5
75	2.0	2.0	2.0	2.0	2.0	2.0	2.0

T _{Flow} (target) [°C]	Set maximum burner anti-cycling time [min]					
	35	40	45	50	55	60
30	29.0	33.1	37.2	41.3	45.4	49.5
35	26.0	29.6	33.3	36.9	40.5	44.2
40	23.0	26.2	29.4	32.5	35.7	38.9
45	20.0	22.7	25.5	28.2	30.9	33.6
50	17.0	19.3	21.5	23.8	26.1	28.4
55	14.0	15.8	17.6	19.5	21.3	23.1
60	11.0	12.4	13.7	15.1	16.5	17.8
65	8.0	8.9	9.8	10.7	11.6	12.5
70	5.0	5.5	5.9	6.4	6.8	7.3
75	2.0	2.0	2.0	2.0	2.0	2.0

Effective burner anti-cycling times **D.002** at max. target flow temperature 50 °C

T _{Flow} (target) [°C]	Set maximum burner anti-cycling time [min]						
	2	5	10	15	20	25	30
30	2.0	4.0	7.3	10.7	14.0	17.3	20.7
35	2.0	3.5	6.0	8.5	11.0	13.5	16.0
40	2.0	3.0	4.7	6.3	8.0	9.7	11.3
45	2.0	2.5	3.3	4.2	5.0	5.8	6.7
50	2.0	2.0	2.0	2.0	2.0	2.0	2.0

T _{Flow} (target) [°C]	Set maximum burner anti-cycling time [min]					
	35	40	45	50	55	60
30	24.0	27.3	30.7	34.0	37.3	40.7
35	18.5	21.0	23.5	26.0	28.5	31.0
40	13.0	14.7	16.3	18.0	19.7	21.3
45	7.5	8.3	9.2	10.0	10.8	11.7
50	2.0	2.0	2.0	2.0	2.0	2.0

10.3.5 Setting the hydraulic operating mode



Note

Different hydraulic operating modes are available depending on the product variant.

The heating water volume flow that is established by the internal heating pump in the heating installation is used to transfer the heat input. To build up the volume flow, different hydraulic operating modes are available, which you can select via **D.170**.

Depending on the setting for diagnostics code **D.170**, fine adjustments are possible via diagnostics codes **D.171** to **D.175**.

	2	3	4
	D.171	D.172 + 173 + 174	D.175
	•		
	•	•	
	•		
			•

D.170 setting

Description



2: Bypass, Δp-const.

Constant pressure pump control type
The internal heating pump works in constant pressure in the heating installation. The pressure level can be selected between 100 and 400 mbar via **D.171**.

The internal circulation valve is only opened according to requirements in order to maintain minimum circulation. If required, a maximum opening pressure can be set via **D.174**.



3: Spread ΔT

Spread pump control type
The internal heating pump works at a temperature spread between the flow and return temperature. The target is the spread level of the heating system and not the pressure supply. The target value for the spread is specified via **D.172**.

The work area of the heating pump for the spread regulation can be set via **D.173** and **D.174**.



4: Fixed pump stage

Pump curve pump control
The internal pump works on a selected pump curve. The volume flow and the pressure for the heating system result via the pump curve and the system resistance that is present. The target value for the pump curve is specified via **D.175**.

There is no control system for pressure or temperature; the pump works on a fixed pump curve.

This pump mode is preferred for homogeneous heat transfer if a low loss header, decoupling module, hydraulic cascading and a buffer cylinder is installed.



Heating system with radiators



Underfloor heating systems



Heating system with radiators and decentralised underfloor heating

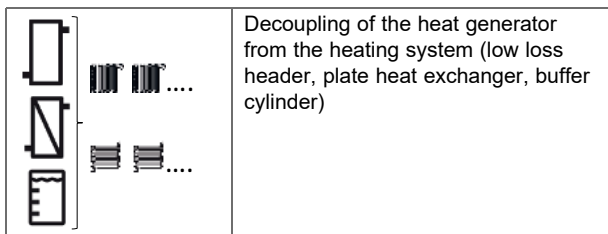

Decoupling of the heat generator from the heating system (low loss header, plate heat exchanger, buffer cylinder)

- ▶ Select parameter **D.170** and, if required, **D.171** to **D.175** in order to adjust the hydraulic operating mode of the heat generator to the heating installation. (→ Section 8.3)

10.3.6 Setting the pressure level for supplying the heating system

The heating system is supplied via the pump pressure, this results in a volume flow. The pump pressure setting is significant. Diagnostics code **D.170** can be used to set the pump control type. (→ Section 10.3.5) The standard selection is "constant pressure". The correct pump pressure is selected via diagnostics code **D.171** and **not** mechanically at the circulation valve.

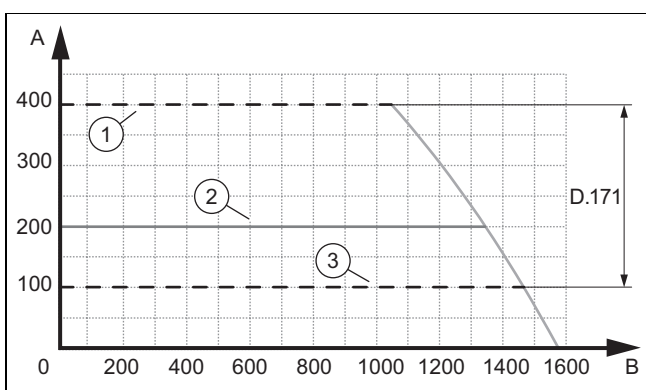

- | | | | |
|---|------------------|---|------------------|
| A | Pressure [mbar] | 2 | Factory setting |
| B | Flow rate [l/h] | 3 | Minimum pressure |
| 1 | Maximum pressure | | |

- ▶ Set the pressure level via **D.171**. (→ Section 8.3)

You should only change the circulation valve setting if the setting of the maximum pump pressure under **D.171** has not led to the ideal supply of the heating system.

- ▶ If **D.171** is set to 400 mbar and the heat supply is still not sufficient, readjust the pressure via the circulation valve.
- ▶ Remove the front casing. (→ Section 7.10.2)
- ▶ Hinge the electronics box downwards.

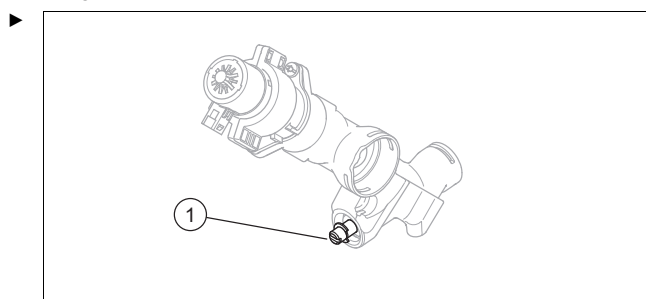

Regulate the pressure at the circulation valve (1) in a clockwise direction.

Position of the adjusting screw	Pressure	Comment
Right-hand stop (turned all the way down)	0.035 MPa (0.350 bar)	If the radiators do not heat up sufficiently at the factory setting.

- ▶ Hinge the electronics box upwards.
- ▶ Install the front casing. (→ Section 7.11)

10.3.7 Pump curves

Validity: VU 10CS/1-5 (N-GB) ecoTEC plus 610 OR VU 15CS/1-5 (N-GB) ecoTEC plus 615 OR VU 20CS/1-5 (N-GB) ecoTEC plus 620 OR VUW 20/26CS/1-5 (N-GB) ecoTEC plus 826

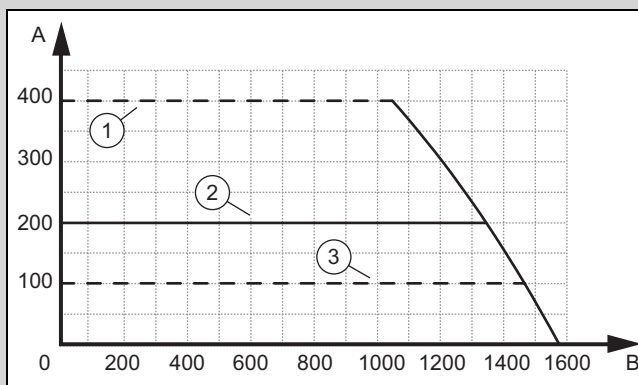

- | | | | |
|---|------------------|---|------------------|
| A | Pressure [mbar] | B | Flow rate [l/h] |
| 1 | Maximum pressure | 3 | Minimum pressure |
| 2 | Factory setting | | |

Validity: VU 25CS/1-5 (N-GB) ecoTEC plus 625 OR VU 30CS/1-5 (N-GB) ecoTEC plus 630 OR VUW 25/32CS/1-5 (N-GB) ecoTEC plus 832 OR VUW 30/36CS/1-5 (N-GB) ecoTEC plus 836

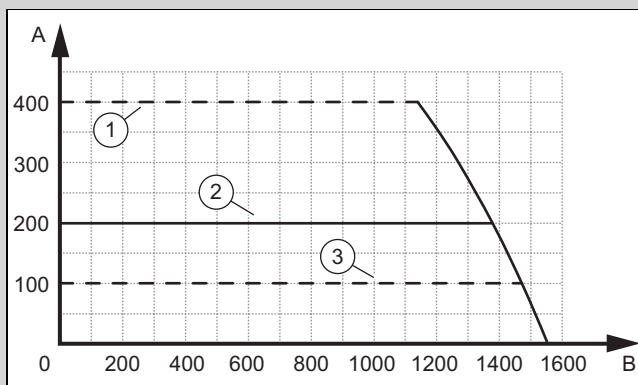

- | | | | |
|---|------------------|---|------------------|
| A | Pressure [mbar] | B | Flow rate [l/h] |
| 1 | Maximum pressure | 3 | Minimum pressure |
| 2 | Factory setting | | |

Validity: VU 35CS/1-5 (N-GB) ecoTEC plus 635 OR VUW 30/40CS/1-5 (N-GB) ecoTEC plus 840

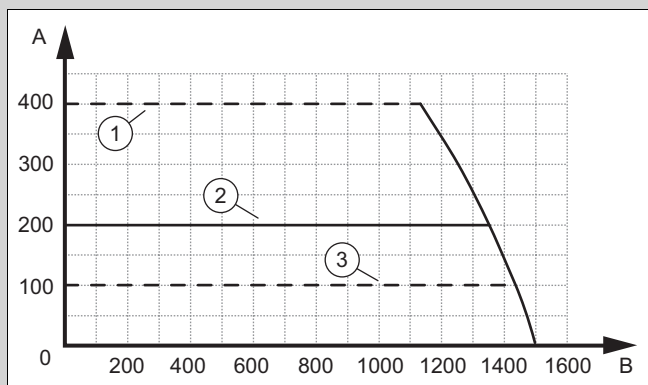

A	Pressure [mbar]	B	Flow rate [l/h]
1	Minimum pressure	3	Factory setting
2	Maximum pressure		

Underfloor heating

Direct supply is only possible via the internal heating pump. However, carefully check the potential of the internal heating pump.

Underfloor heating systems are heating surfaces with a low spread and, therefore, a high demand for cycles. The larger the cycle, the higher the pressure loss. The potential of the internal heating pump for such systems is limited. If the potential of the internal heating pump is not sufficient, the heat generator must be decoupled from the heating surfaces (e.g. using a low loss header, heat exchanger, buffer cylinder, etc.). Beyond the decoupling, an external heating pump can be designed exactly for the application.

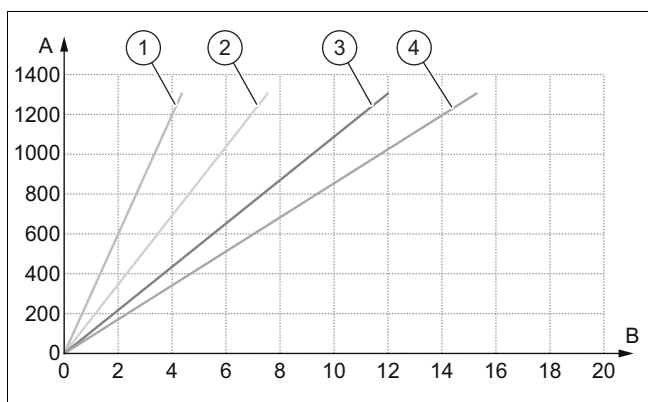

A	Potential heating system cycles [l/h]	1	3 K system
B	Maximum heat output of underfloor heating systems [kW]	2	5 K system
		3	8 K system
		4	10 K system



Note

The diagram is only used as a rough guide. It does not replace planning. Furthermore, there is no functional warranty for a heating system, since each heating system is individual and requires planning.

10.3.8 Setting the heat curve

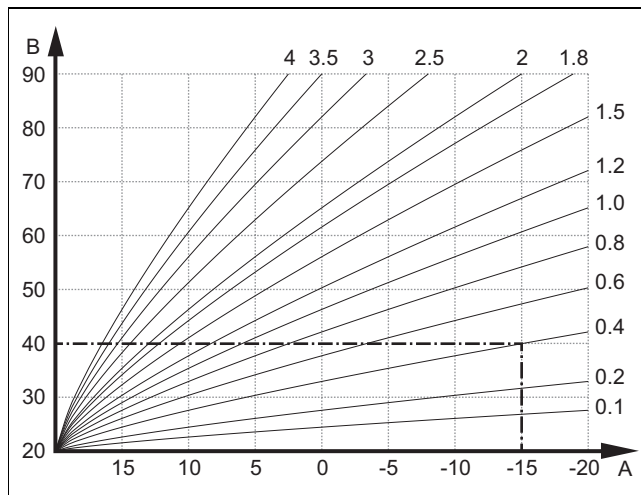

A Outdoor temperature °C B Target flow temperature °C

The figure shows the possible heat curves of 0.1 to 4.0 for a target room temperature of 20 °C. If, for example, heat curve 0.4 is selected, a flow temperature of 40 °C is maintained at an outdoor temperature of -15 °C.

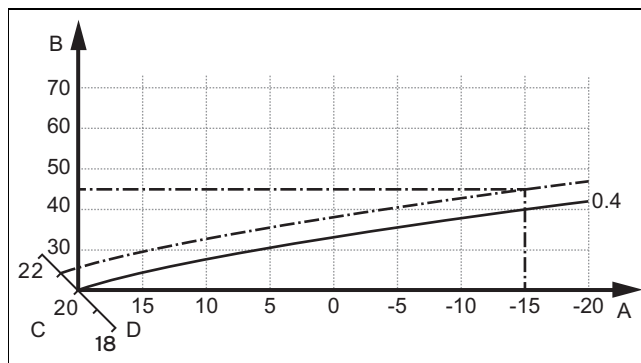

A Outdoor temperature °C C Target room temperature °C
B Target flow temperature °C D Axis a

If the heat curve 0.4 is selected and 21 °C is specified for the target room temperature, the heat curve is then translated, as shown in the figure. The heat curve is displaced according to the value of the target room temperature along axis a which is angled at 45°. At an outdoor temperature of -15 °C, the control system provides a flow temperature of 45 °C.

- ▶ Navigate to **MENU** → **SETTINGS** → **Installer level** → **Installation configuration** → **Heating** → **Heat curve**.
- ▶ Use the scroll bar to select the required value.
- ▶ Exit the menu level. (→ Section 8.8)

10.4 Adapting the domestic hot water settings

10.4.1 Setting the domestic hot water temperature

Validity: Product with integrated hot water generation OR Product with connected domestic hot water cylinder



Danger!

Risk of death from legionella.

Legionella multiply at temperatures below 60 °C.

- ▶ Ensure that the end user is familiar with all of the Anti-legionella measures in order to comply with the applicable regulations regarding legionella prevention.

1. Observe the applicable regulations regarding legionella prevention.
2. From the basic display, press .
3. Set the required domestic hot water temperature.

Validity: Product with system control

- ▶ First, set the target domestic hot water temperature on the heat generator's control panel to the maximum value before you connect the system control (eBUS).
- ▶ Set the required domestic hot water temperature on the system control (→ Operating instructions/installation instructions for the system control).

Condition: System control connected

- ▶ Check the domestic hot water generation. (→ Section 9.16)

10.4.2 Setting solar thermal post-heating

Validity: Product with integrated hot water generation



Note

Ensure that the heat generator remains switched on over the summer months.

Condition: Solar connection set installed, inlet temperature sensor available

- ▶ Set diagnostics code **D.058**. (→ Section 8.3)
- ▶ Ensure that the temperature at the product's cold water connection does not exceed 70 °C.

10.5 Displaying the product information

You can call up current product status information by scanning a QR code using the **myVAILLANT pro** app.

- ▶ Download the free **myVAILLANT pro** app onto your mobile device from Google Play® or the App Store®.



Note

Please note that, to avoid additional costs, the Internet connection tariff should not have any time or data limits.

- ▶ Install the free **myVAILLANT pro** app on your mobile device.
- ▶ Start the **myVAILLANT pro** app on your mobile device and log in.
- ▶ On the heat generator's display, navigate to **MENU** → **SETTINGS** → **Installer level** → **QR service code**.



Note

The QR code with encrypted product status information is displayed for 60 seconds, and is updated and refreshed with the latest information every 60 seconds.

- ▶ Scan the QR code using the app.
 - ◀ The following product status information is shown in the app.
 - Status history of the fault codes, maintenance codes and status codes
 - Product status with operating mode and active actuators
 - System information

11 Handing over to the end user

- ▶ At the time of commissioning complete all relevant sections of the Benchmark commissioning checklist, located at the rear of this document.
- ▶ For IE: Complete a "Declaration of Conformity" to indicate compliance to I.S. 813. An example of this is given in the current edition of I.S. 813.
- ▶ When you have finished the installation, affix the enclosed sticker (which requests that the user reads the instructions) to the front of the product in the end user's language.
- ▶ Draw attention, to the current issue of the Gas Safety (Installation and Use) Regulations, Section 35, which imposes a duty of care on all persons who let out any property containing a gas appliance in the UK.
- ▶ Explain to the end user how the safety devices work and where they are located.
- ▶ Inform the end user how to handle the product.
- ▶ In particular, draw attention to the safety warnings that the end user must follow.
- ▶ Inform the end user that they must have the product maintained in accordance with the specified intervals.
- ▶ Pass all of the instructions and documentation for the product to the end user for safe-keeping.
- ▶ Inform the end user about measures taken to ensure the supply of combustion air and flue gas guiding, and instruct the operator that he must not make any changes.

- ▶ Inform the end user that they must not store or use explosive or highly flammable substances (such as petrol, paper or paint) in the installation room of the product.
- ▶ Complete and sign off the Benchmark commissioning check list.
- ▶ Complete and sign off the guarantee documentation.

12 Inspection and maintenance

12.1 Complete Service Interval Record section

- ▶ After servicing, complete the relevant Service Interval Record section of the Benchmark Checklist located on the inside back pages of this document.

12.2 Using original seals

If you replace components, use only the enclosed new original seals; additional sealing materials are not required.

12.3 Maintenance interval

A service interval can be defined in two ways. A service interval must not be greater than 1 year.

Use **D.084** to establish the link to the countdown of operating hours.

Use **D.161** to establish the link to a date.

The service message regarding the event that occurs earlier appears (the hours have elapsed or the date is reached).

If you only set one of the two diagnostics codes (**D.084** or **D.161**), the other diagnostics code in each case is automatically reset to the factory setting.

If you select **Not set** for **D.084**, the service message regarding the operating hours is deactivated. The service message for the date remains active and cannot be deactivated.

The service message regarding the event that occurs earlier appears (the hours have elapsed or the date is reached).

Once the service work is complete, you must set the maintenance intervals again. (→ Section 12.3.1)

12.3.1 Setting/resetting the maintenance interval

1. Set diagnostics code **D.084** or **D.161**. (→ Section 8.3)



Note

The operating hours until the next inspection/maintenance must be set individually (depending on the type of unit and the heat output).

Operating mode	Guideline value for the operating hours (in relation to one year)
Heating mode	4000 h
Heating and domestic hot water mode	5000 h

2. Exit the diagnostics codes. (→ Section 8.3.1)
3. Exit the menu level. (→ Section 8.8)

12.4 Actuator test

MENU → **SETTINGS** → **Installer level** → **Test modes** → **Actuator test**

The actuator test allows you to actuate and test individual components in the heating installation.

Actuator test (→ Appendix H)

12.5 Inspection and maintenance

- ▶ You must carry out an annual inspection of the product. The annual inspection can be effectively performed without removing components by requesting data from the Diagnostics codes, carrying out the simple visual checks indicated in the table in the appendix and performing a flue gas measurement. The maintenance intervals and their scope are determined by the heating engineer based on the condition of the boiler found during the inspection. All inspection and maintenance work should be performed in the order specified in the table in the appendix.

During any inspection and maintenance or after change of parts of the combustion circuit, the following must be checked:

- The boiler has been installed in accordance with the relevant installation instructions.
 - The integrity of the flue gas installation and flue seals is in accordance with the relevant flue installation instructions enclosed.
 - Visual, the integrity of the boiler combustion circuit and relevant seals (paying particular attention to the burner door seal).
 - The gas inlet working pressure at maximum rate.
 - The gas flow rates.
 - Correctness of electrical, water and gas connections.
 - Correctness of the water pressure.
 - The condition of the whole system, in particular the condition of radiator valves, evidence of leakage from the heating system and dripping taps.
- ▶ Correct any faults before proceeding.

12.6 Preparing the maintenance work

1. Switch off the product.
2. Disconnect the product from the power grid.
3. Remove the front casing. (→ Section 7.10.2)
4. Close the gas stopcock.
5. Close the service valves in the heating flow and in the heating return.
6. Close the service valve in the cold water pipe.
7. Drain the product to clean hydraulic components (→ Section 12.9).
8. Ensure that water does not drip on live components (e.g. the electronics box).
9. Use only new seals and o'ring. Do not use additional compounds.

12.7 Removing/installing the compact thermal module

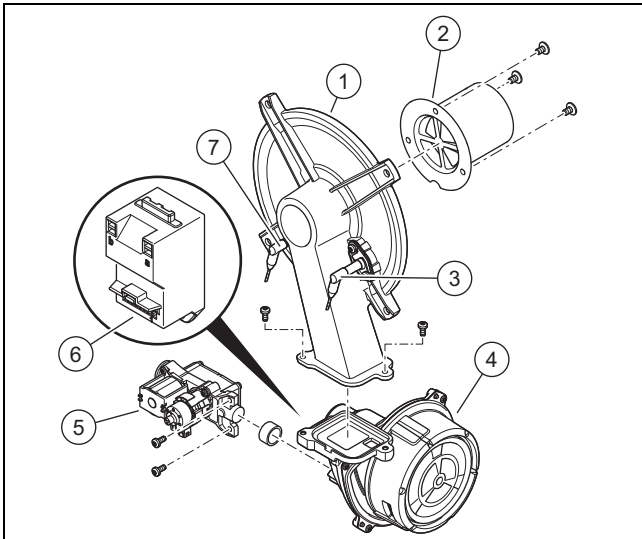

- | | | | |
|---|---------------------|---|----------------------|
| 1 | Burner flange | 5 | Gas valve assembly |
| 2 | Premix burner | 6 | Ignition transformer |
| 3 | Control electrode | 7 | Ignition electrode |
| 4 | Speed-regulated fan | | |



Note

Only touch the control electrode at the ceramic section. Cleaning the control electrode is prohibited.

12.7.1 Removing the compact thermal module



Danger!

Risk of death and risk of material damage caused by hot flue gas.

The seal, insulating mat and self-locking nuts on the burner flange must not be damaged. Otherwise, hot flue gases may escape and cause personal injury and material damage.

- ▶ Replace the seal each time you open the burner flange.
- ▶ Replace the self-locking nuts on the burner flange each time you open the burner flange.
- ▶ If the insulating mat on the burner flange or on the back wall of the heat exchanger shows signs of damage, replace the insulating mat.

1. Disconnect the product from the power supply.
2. Close the gas stopcock.
3. Remove the front casing. (→ Section 7.10.2)
4. Hinge the electronics box downwards.

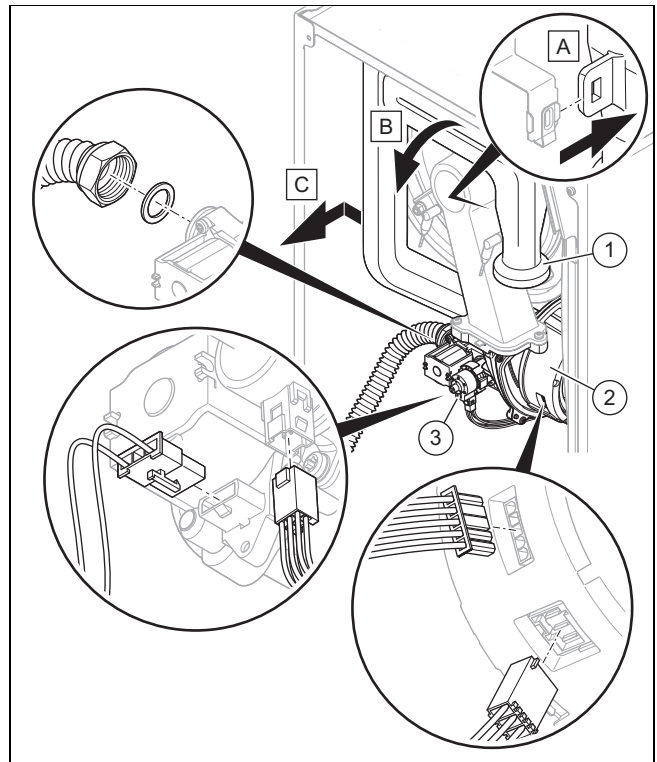

5. Unscrew the air intake pipe (1) from the upper retainer and remove the air intake pipe from the intake stub, as shown in the figure.
6. Unscrew the union nut from the gas valve assembly (3).
7. Remove the two plugs from the gas valve assembly.
8. Remove the plug or, if necessary, the two plugs from the fan motor (2) by pushing in the latching lug.

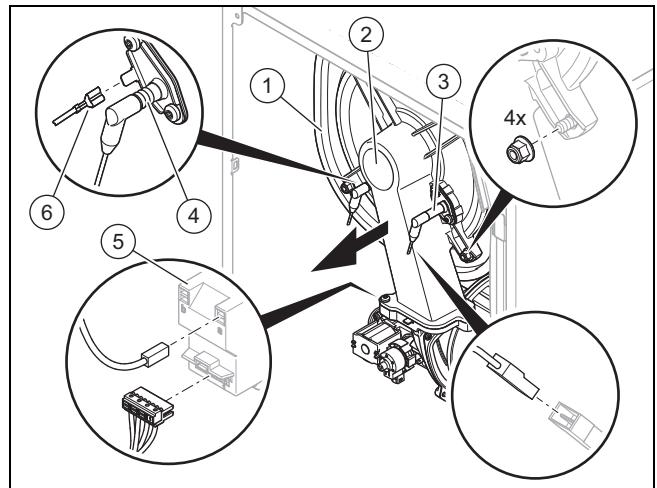

9. Remove the earth cable (6) from the ignition electrode (4), the two plugs from the ignition transformer (5) and the plug for the control electrode's cable (3).
10. Remove the four nuts from the burner flange (2).
11. Remove the entire compact thermal module from the heat exchanger (1).
12. Check the burner and burner insulating mat for damage. (→ Section 12.8.3)
13. Check the heat exchanger for damage.

Result:
Heat exchanger damaged

 - ▶ Replace the heat exchanger. (→ Section 13.7.8)
14. Check the heat exchanger for dirt.

Result:

Heat exchanger dirty

► Clean the heat exchanger. (→ Section 12.8.2)

15. Check the insulating mat on the heat exchanger for damage.

Result:

Insulating mat damaged

► Replace the insulating mat (→ Spare parts instructions for the heat exchanger insulating mat).

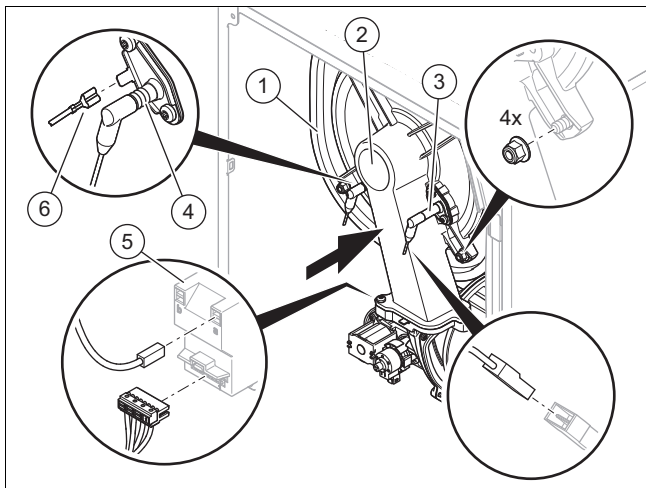
12.7.2 Installing the compact thermal module

1. Connect the compact thermal module to the heat exchanger (1).
2. Tighten the four new nuts in a cross-wise pattern until the burner flange fits closely and uniformly onto the mating surfaces.
 - Tightening torque: 6 Nm
3. Reconnect the earth cable (6) to the ignition electrode (4). Reconnect the two plugs on the ignition transformer (5) and the plug for the control electrode's cable (3).

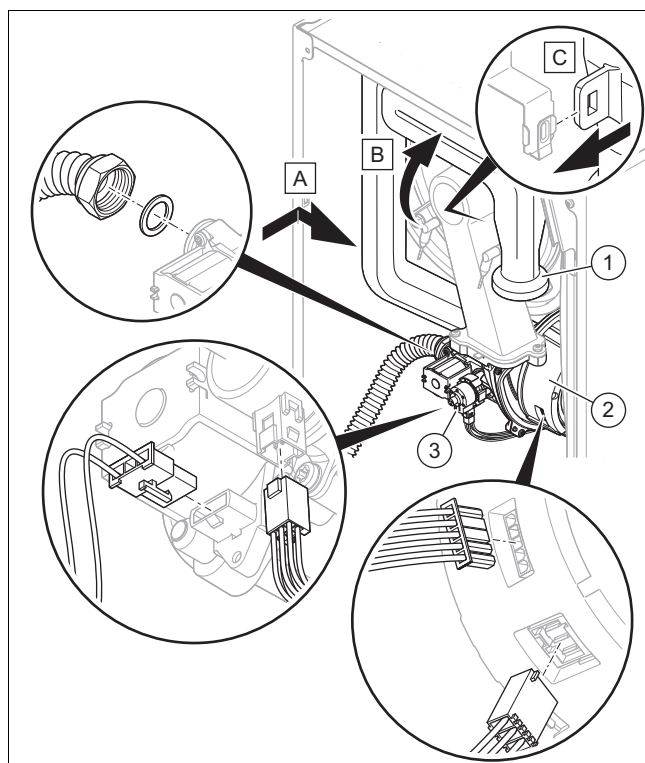

4. Reconnect the plug or, if required, the two plugs to the fan motor (2).
5. Reconnect the two plugs to the gas valve assembly (3).
6. Screw the union nut onto the gas valve assembly with a new seal. In the process, secure the gas pipe against twisting. Tightening torque, see appendix.
7. Open the gas stopcock.
8. Check the product for tightness. (→ Section 9.17)
9. Check whether the sealing ring is positioned correctly in the air intake pipe.
10. Plug the air intake pipe (1) onto the intake stub and push the air intake pipe into the upper retainer, as shown in the figure.
11. Check the gas connection pressure/gas flow pressure. (→ Section 9.13.3)
12. Observe the tightening torques for the screw plug on the gas valve assembly and on the gas isolation valve, see appendix.

12.8 Cleaning/checking the components

1. Carry out the preparatory work before cleaning/checking any of the components. (→ Section 12.8.1)
2. Carry out the work required to finish the task after cleaning/checking any of the components. (→ Section 12.8.7)

12.8.1 Preparing the cleaning and inspection work

1. Temporarily decommission the product. (→ Section 14.2)
2. If required, remove the installed modules from below the product (→ Module installation instructions).
3. Remove the front casing. (→ Section 7.10.2)
4. Hinge the electronics box downwards.
5. Protect the electronics box against spraying water.
6. Remove the compact thermal module. (→ Section 12.7.1)

12.8.2 Cleaning the heat exchanger

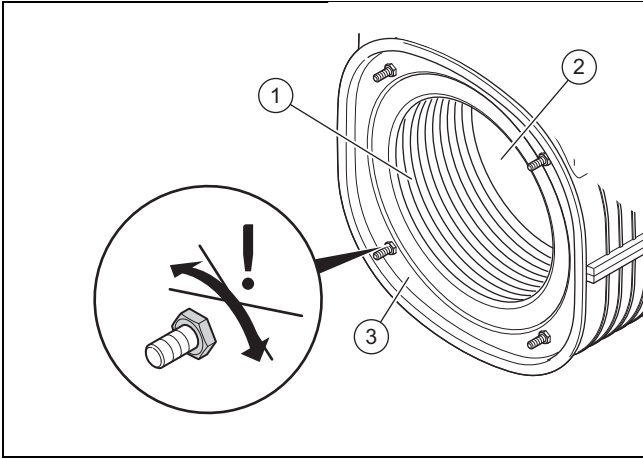

- Never undo the four nuts on the stud bolt or tighten them.
- Clean the spiral immersion heater (1) of the heat exchanger (3) using a plastic brush and, if required, vinegar (up to max. 5% acid content).
 - Cleaning agent reaction time: 20 min
- Wipe away the loosened dirt with a damp cloth. Ensure that the insulating mat (2) on the rear of the heat exchanger remains dry.
 - ◁ Moisture may drain out of the heat exchanger via the condensate siphon.
- Check the insulating mat on the heat exchanger for damage.

Result:
Insulating mat damaged

 - ▶ Replace the insulating mat (→ Spare parts instructions for the heat exchanger insulating mat).
- Clean the condensate siphon. (→ Section 12.8.5)

12.8.3 Checking the burner and burner insulating mat for damage

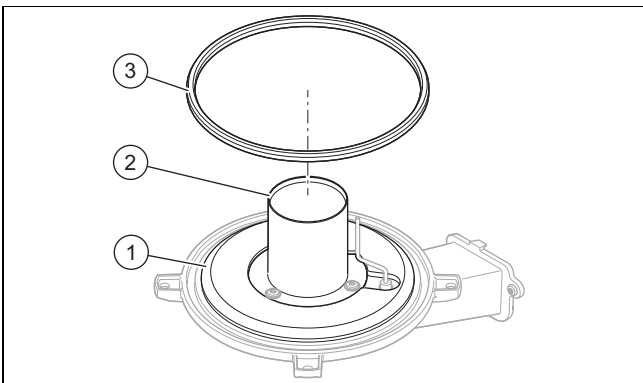

- Check the surface of the burner (2) for damage, such as hairline cracks, dents or other deformations.

Result:
Burner damaged

 - ▶ Replace the burner flange. (→ Section 13.7.5)
- Fit a new burner flange seal (3).
- Check the insulating mat (1) on the burner flange for damage.

Result:
Insulating mat damaged

 - ▶ Replace the burner flange. (→ Section 13.7.5)

12.8.4 Checking and, if required, supplementing the pre-charge pressure for the internal expansion vessel

- Drain the product. (→ Section 12.9)

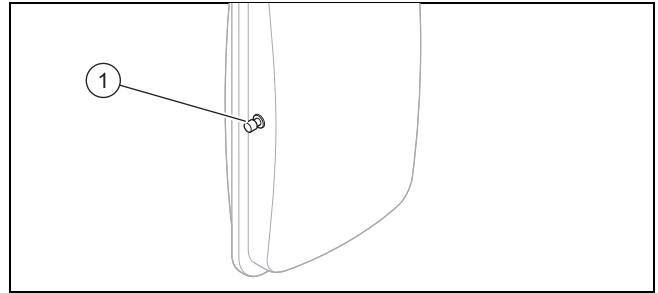

- Check the pre-charge pressure of the expansion vessel at the expansion vessel valve (1).
 - Working materials: U tube manometer
 - Working materials: Digital pressure gauge

Result 1:
≥ 0.075 MPa (≥ 0.750 bar)
The pre-charge pressure is in the permissible range.

Result 2:
< 0.075 MPa (< 0.750 bar)

 - ▶ Top up the expansion vessel in accordance with the static height of the heating installation, ideally with nitrogen, otherwise with air. Ensure that the drain valve is open when topping up.
- If water escapes from the valve of the expansion vessel, you must replace the expansion vessel. (→ Section 13.7.9)
- Fill the heating installation. (→ Section 9.9)
- Purge the heating installation. (→ Section 9.10)

12.8.5 Cleaning the condensate siphon

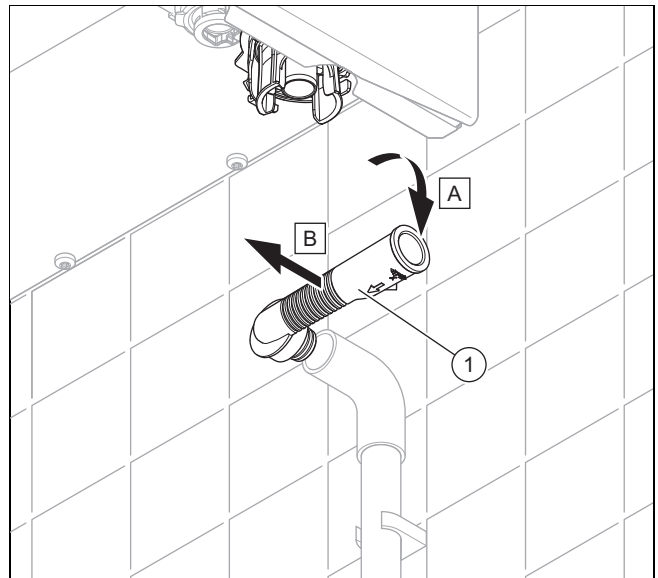

- Remove the condensate adapter (1).

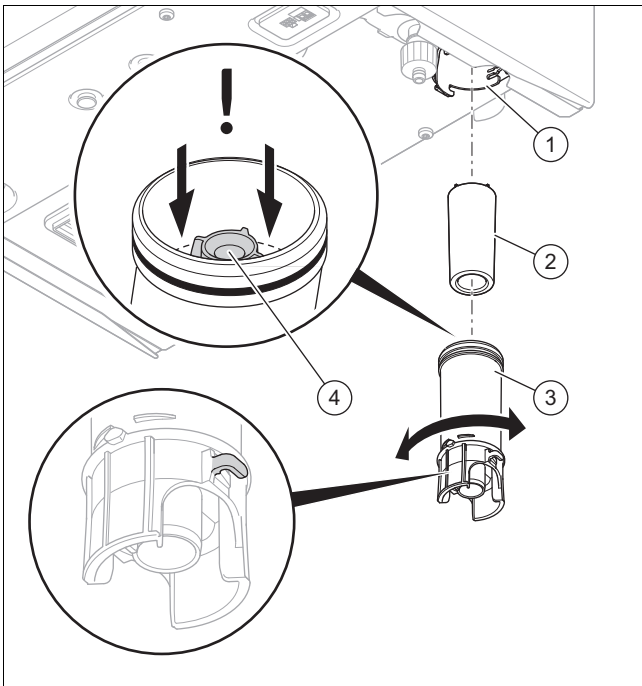

2. Loosen the lower section of the siphon (3) by turning the upper section of the siphon (1) by a quarter turn and pull it downwards and out.
3. Remove the float (2).
4. Flush out the lower section of the siphon with water.
5. Fill the lower section of the siphon with water up to a filling level 10 mm below the condensate discharge (4).
6. Insert the float.
7. Install the lower section of the siphon on the condensate siphon.
8. Reinstall the condensate adapter and check for tightness.

12.8.6 Cleaning the strainer in the cold water inlet

Validity: Product with integrated hot water generation

1. Close the cold-water isolation valve.
2. Drain the product on the domestic hot water side.
3. Hinge the electronics box forwards.

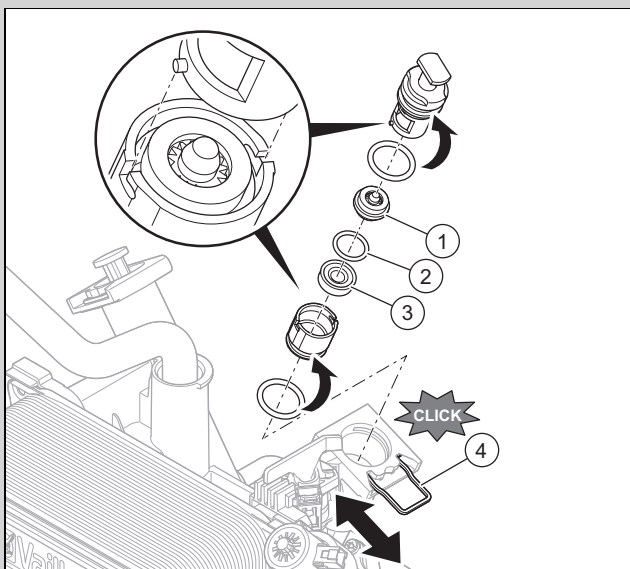

4. Pull the clip (4) out to the maintenance position. The clip is secured against falling out.

5. Pull the assembly straight out of the product without any rotational movement.
6. Disconnect the lowest section of the assembly by rotating the upper section.
7. Note the installation position. Remove the flow rate limiter (1), O-ring (2) and strainer (3).
8. Rinse the strainer under a jet of water, holding it against the direction of flow.
9. If the strainer is damaged or it can no longer be cleaned sufficiently, you must replace the strainer.
10. Always use new O-rings. Reinsert the flow rate limiter.
11. Reinsert the strainer, O-ring and flow rate limiter in the correct installation position.
12. Slide the clip back in until you hear it click into place.
13. Open the cold-water isolation valve.

12.8.7 Completing cleaning and inspection work

1. Install the compact thermal module. (→ Section 12.7.2)
2. Hinge the electronics box upwards.
3. Open all service valves and the gas stopcock if this has not yet been done.
4. Check the product for tightness. (→ Section 9.17)
5. Install the front casing. (→ Section 7.11)
6. Ensure that the front casing incl. front panel is completely installed below the display.
7. If required, install the modules below the product (→ Module installation instructions).
8. Establish the power supply if this has not yet been done.
9. Switch the product back on if this has not yet been done. (→ Section 9.4)

12.8.8 Checking the Protection kit, if available

- ▶ If a Protection kit is available, follow the instructions for the Protection kit for the check.

12.8.9 Checking the filling pressure of the heating installation

1. Check the filling pressure of the heating installation, top it up with heating water, if necessary, and purge it.
2. Fill the heating installation. (→ Section 9.9)
3. Purge the heating installation. (→ Section 9.10)

12.8.10 Checking the quality of the heating water

- ▶ Check the quality of the heating water: Clarity (clouding), correct inhibitor and pH value. (→ Section 9.3)

12.9 Draining the product

1. Temporarily decommission the product. (→ Section 14.2)
2. Close the service valves of the product.
3. Close the gas stopcock.
4. Start up the product.
5. Start check programme **P.008**. (→ Section 8.4)
6. Open the drain valves.
 - ◀ The product (heating circuit) is drained.
7. Close the drain valve.
8. Temporarily decommission the product. (→ Section 14.2)

12.10 Completing inspection and maintenance work

- ▶ Start a test operation after the maintenance.
- ▶ Check the heating mode and, if required, the domestic hot water generation (if available).
- ▶ Check the gas connection pressure/gas flow pressure. (→ Section 9.13.3)
- ▶ Check the O₂ content. (→ Section 9.13.4)
- ▶ If required, reset the maintenance interval. (→ Section 12.3.1)
- ▶ Fill out the relevant Service Record section in the Benchmark Checklist.

13 Troubleshooting

13.1 Checking the data overview

1. Navigate to **MENU** → **SETTINGS** → **Installer level** → **Data overview**.
2. Read the limp home mode and fault history to determine whether a component is defective. (→ Section 13.3.2.1)

13.2 Service messages

If the set maintenance interval has passed or if a service message has been issued,  appears in the display. The product is not in fault mode.

If multiple service messages occur at the same time, these are shown in the display. Each service message must be confirmed.

Maintenance codes (→ Appendix I)

13.3 Fault messages

If several faults occur at the same time, the display shows the faults. Each fault must be confirmed.



Note

Due to a condensate blockage test after the last ignition attempt, fault messages **F.028**, **F.029** and **F.347** appear after a delay. Wait for the fault displays.

13.3.1 Eliminating faults

- ▶ Eliminate the faults (fault messages/fault codes) after checking the measures.
Fault codes (→ Appendix F)
- ▶ Press the reset button  (hold it for longer than three seconds) in order to start up the product again.
 - Maximum number of repetitions: 3
- ▶ If you are unable to eliminate the fault and the fault recurs despite reset attempts, contact customer service.

13.3.2 Fault history/limp home mode history

If faults have occurred, the last ten (max.) fault messages are available in the fault history/limp home mode history.

13.3.2.1 Requesting/clearing the fault history

1. Call up the installer level. (→ Section 8.2)
2. Navigate to the **Fault history** menu.
 - ◀ The display shows the number of faults that have occurred, the fault numbers and the corresponding plain text display.
3. Use the scroll bar to select the required fault message.
4. To delete the fault history, set diagnostics code **D.094**. (→ Section 8.3)
5. Exit the menu level. (→ Section 8.8)

13.4 Limp home mode messages

The limp home mode messages are divided into reversible and irreversible messages.

Reversible **L.XXX** codes occur temporarily and eliminate themselves. Reversible limp home mode messages are not shown on the display. Navigate to **MENU** → **SETTINGS** → **Installer level** → **Data overview**.

Irreversible **N.XXX** codes require action from the competent person.

When an irreversible limp home mode message occurs for the first time, it appears on the display and must be confirmed. If the same irreversible limp home mode message occurs multiple times, it is stored in the limp home mode history. Navigate to **MENU** → **SETTINGS** → **Installer level** → **Limp home mode history**.

Reversible limp home mode codes (→ Appendix J)

Irreversible limp home mode codes (→ Appendix K)

13.4.1 Requesting the limp home mode history

1. Call up the installer level. (→ Section 8.2)
2. Navigate to the **Limp home mode history** menu.
 - ◀ The display shows a list of the limp home mode messages (**N.XXX**) that are displayed.
3. Use the scroll bar to select the required limp home mode message.
4. Eliminate the cause and confirm the limp home mode message.
5. Exit the installer level. (→ Section 8.2.1)

13.5 Resetting parameters to factory settings

1. Note all of the relevant settings in the **Current** column of the "Diagnostics codes" table in the appendix. (→ Appendix D)



Note

When you reset to the factory settings, all of the installation-specific settings are deleted. The values for diagnostics codes **D.052** and **D.182**, if available, are still automatically saved. (→ Section 8.3)

2. Navigate to **MENU** → **SETTINGS** → **Installer level** → **Factory settings?** or alternatively set diagnostics code **D.096**. (→ Section 8.3)
 - ◀ Parameters are restored to the factory settings.
 - ◀ **F.105** appears because the Offset for the gas valve assembly is missing. You are prompted to enter the value under **D.052** (set gas type: Natural gas) or under **D.182** (set gas type: Liquefied petroleum gas). (→ Section 13.7.7)



3. Check the installation-specific settings and adjust these.
4. Exit the diagnostics codes. (→ Section 8.3.1)
5. Exit the menu level. (→ Section 8.8)

13.6 Eliminating faults in the product



Note

Maximum number of repetitions: 3.

- ▶ Press and hold  for longer than three seconds and release the button.
 - ◀  is shown on the display.
- ▶ When you are prompted to do so, confirm the product reset using .
 - ◀ The product restarts.
- ▶ If you cannot eliminate the fault, contact customer service.

13.7 Replacing defective components

1. Carry out the preparatory work before undertaking any repair work. (→ Section 13.7.2)
2. Carry out the work required to finish the task before undertaking any repair work. (→ Section 13.7.16)

13.7.1 Procuring spare parts

The original components of the product were also certified by the manufacturer as part of the declaration of conformity. If you use other, non-certified or unauthorised parts during maintenance or repair work, this may result in the product no longer meeting the applicable standards, thereby voiding the conformity of the product.

We strongly recommend that you use original spare parts from the manufacturer as this guarantees fault-free and safe operation of the product. To receive information about the available original spare parts, contact the contact address provided on the back page of these instructions.

- ▶ If you require spare parts for maintenance or repair work, use only the spare parts that are permitted for the product.

13.7.2 Preparing the repair work

1. Drain the product if you want to replace water-carrying components of the product. (→ Section 12.9)
2. Temporarily decommission the product. (→ Section 14.2)
3. Disconnect the product from the power grid.
4. If required, remove the installed modules from below the product (→ Module installation instructions).
5. Remove the front casing. (→ Section 7.10.2)

6.

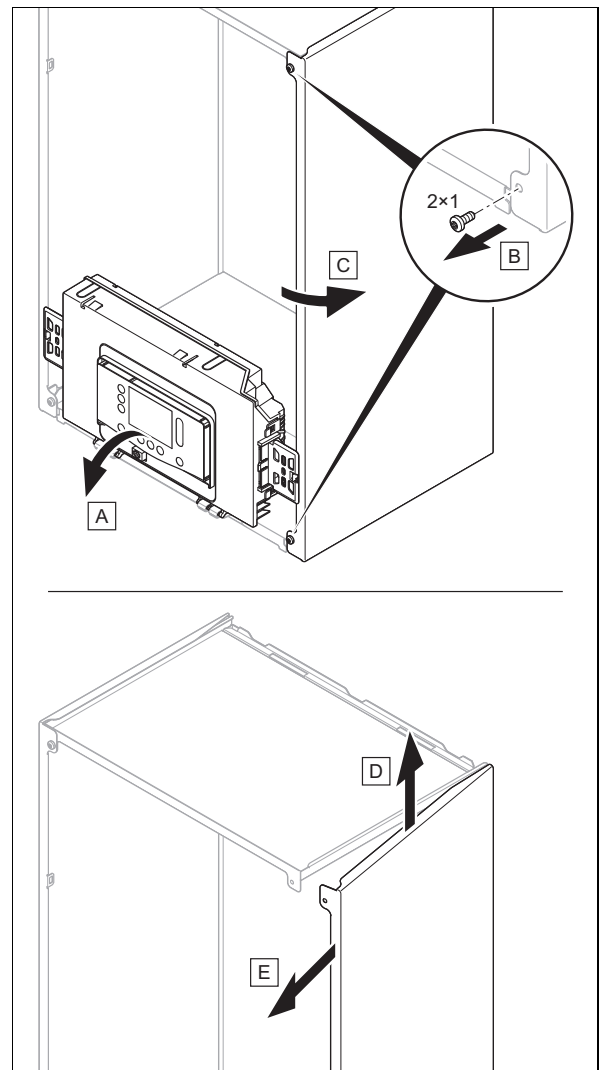

Caution.

Risk of material damage caused by mechanical deformation.

Removing both side casing panels may cause mechanical distortion in the product, which may cause damage to the piping, for example, and potentially result in leaks.

- ▶ Always only remove one side casing panel – never both side casing panels at the same time.

7. Close the gas stopcock.
8. Close the service valves in the heating flow, in the heating return and in the cold water pipe, if you have not already done so.
9. Ensure that water does not drip on live components (e.g. the electronics box).
10. Use only new seals and screws.

13.7.3 Replacing the pump head

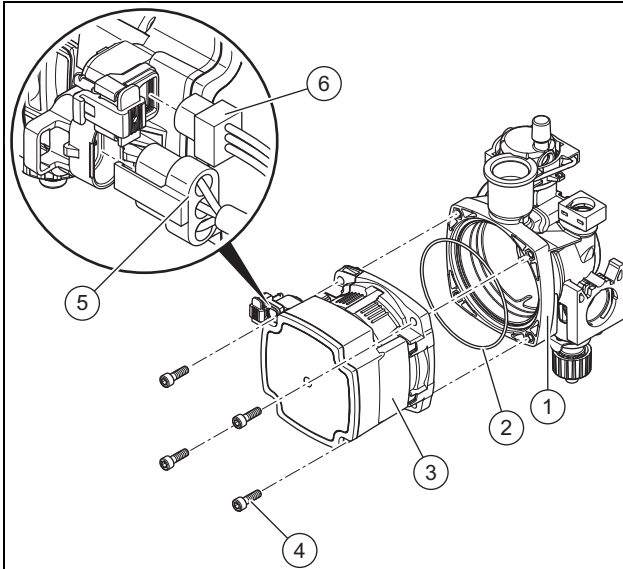

1. Pull out the plugs **(5)** and **(6)** from the pump head.
2. Undo the four screws **(4)**.
3. Remove the pump head **(3)**.
4. Check the inside of the lower section of the pump **(1)** for dirt.

Result 1:

Dirt is present

- ▶ Clean the inside of the lower section of the pump.

Result 2:

Dirt is magnetic

- ▶ Check the installed magnetite separator.

5. Replace the O-ring **(2)**.
6. Secure the new pump head using four new screws at the lower section of the pump.
7. Tighten the four screws in a cross-wise pattern until the pump head on the lower section of the pump fits uniformly. Tightening torque, see appendix.
8. Reconnect the two plugs on the pump head.
9. Fill the heating installation. (→ Section 9.9)
10. Purge the heating installation. (→ Section 9.10)
11. Check the product for tightness. (→ Section 9.17)

13.7.4 Eliminating the condensate discharge blockage (F.028 or F.029)

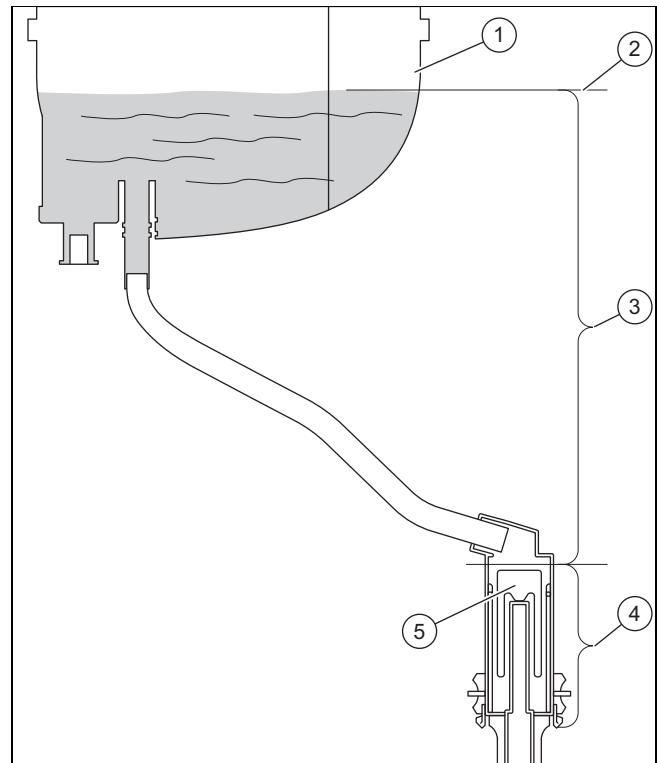

- | | | | |
|---|---|---|--------------------------|
| 1 | Heat cell | 4 | Normal condensate volume |
| 2 | Height of the ignition and control electrode | 5 | Float |
| 3 | Accumulation of condensate in the event of a blockage | | |

If fault **F.028** or **F.029** occurs as a result of a frozen condensate discharge pipe or another blockage cause, maintenance work must be carried out on the condensate siphon (→ Section 12.8.5). It is not sufficient to thaw the condensate discharge pipe.



Note

During maintenance work, note that a large quantity of condensate has collected above the float in the condensate siphon and this may escape when you remove the lower section of the siphon.

Proceed as follows:

- ▶ Thaw the condensate discharge pipe and clean it.
- ▶ Service the condensate siphon.
- ▶ Start up the product again.
- ▶ If the condensate discharge pipe is clear and fault message **F.028** or **F.029** persists, carry out maintenance work on the heat cell (→ Section 12.7).

13.7.5 Replacing the burner



Note

Never replace the burner only, but always replace the burner flange, the burner and the control electrode, as well as all of the seals.

1. Remove the compact thermal module. (→ Section 12.7.1)
2. Remove the ignition electrode. (→ Section 13.7.13)

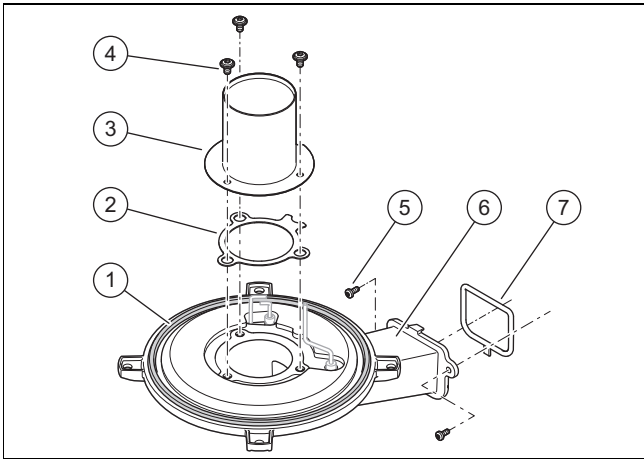

3. Turn the two screws (5) between the burner flange (6) and the fan.
4. Remove the burner flange.
5. Fit the new burner (3) with a new burner seal (2) to the new burner flange.
6. Tighten the three screws (4); for tightening torques, see the appendix.
7. Fit the new burner flange with a new burner flange seal (1). Replace the seal (7) between the burner flange and the fan.
8. Tighten the two screws on the burner flange; for tightening torques, see the appendix.
9. Install the new control electrode on the new burner flange. (→ Section 13.7.13)



Note

Only touch the ignition and control electrodes at the ceramic section.

10. Insert the ignition electrode with a new seal.
11. Install the compact thermal module. (→ Section 12.7.2)
12. Check the O₂ content. (→ Section 9.13.4)

13.7.6 Replacing the fan

1. Remove the gas valve assembly. (→ Section 13.7.7)

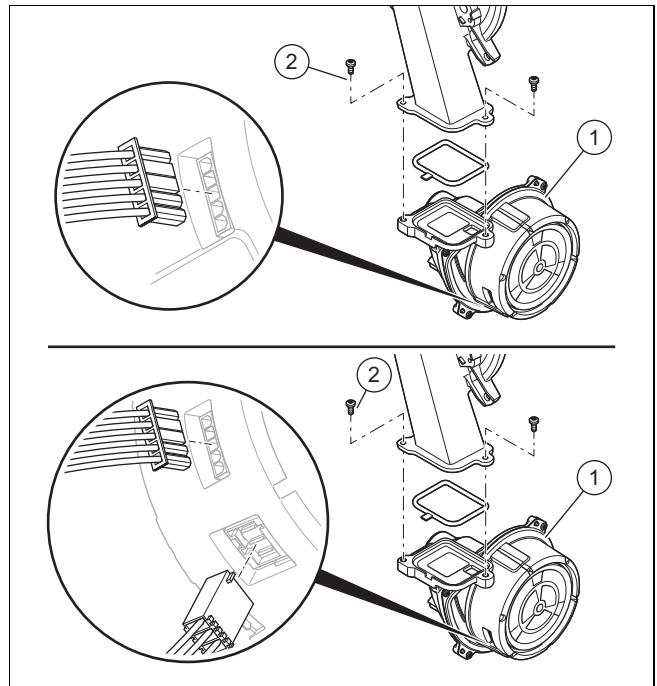

2. Remove the plug or, if required, the two plugs from the fan motor.
3. Unscrew the air intake pipe from the upper retainer, tilt the air intake pipe forwards, and remove the air intake pipe from the intake stub.
4. Unscrew the two screws (2) between the mixture pipe and the fan flange.
5. Remove the fan (1).
6. Insert the new fan. When doing so, replace all of the seals.
7. Screw the two screws between the mixture pipe and the fan flange in tightly. Tightening torque, see appendix.
8. Install the gas valve assembly. (→ Section 13.7.7)
9. Plug the air intake pipe onto the intake stub, tilt the air intake pipe backwards and push the air intake pipe into the upper retainer.
10. Connect the plug or, if required, the two plugs to the fan motor.

13.7.7 Replacing the gas valve assembly

Removing the gas valve assembly

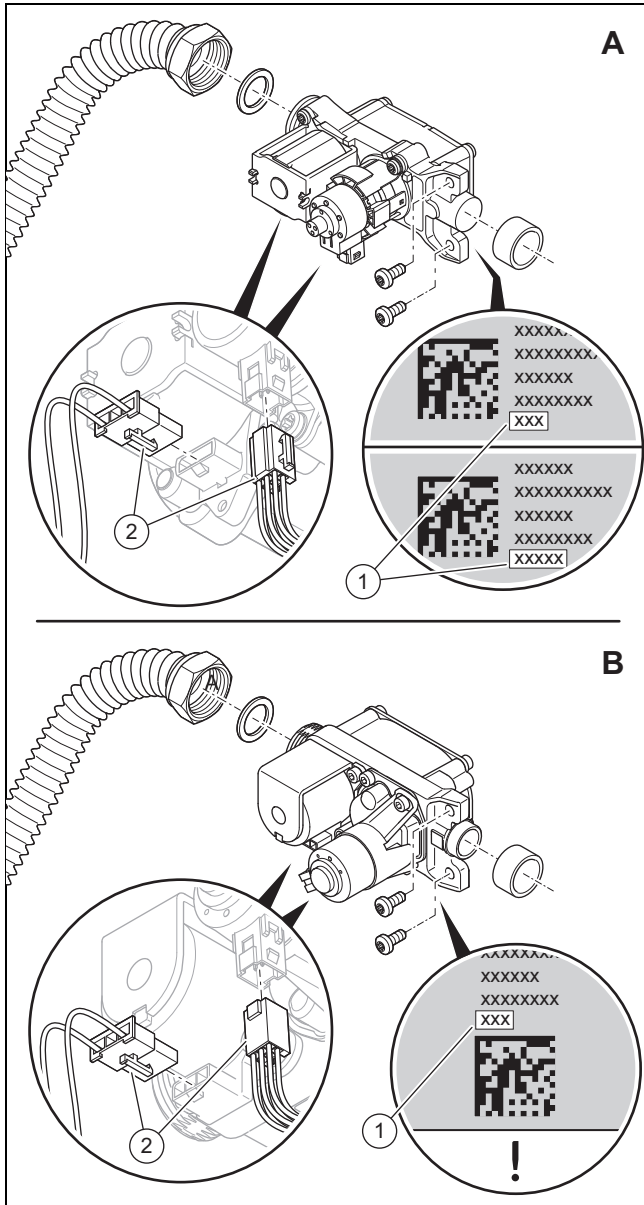

1. Remove the two plugs (2) from the gas valve assembly.
2. Unscrew the union nut from the gas valve assembly.
3. Unscrew two screws to secure the gas valve assembly to the fan.
4. Remove the gas valve assembly.
5. Read the offset (1) that is printed on the rear (type A) or underside (type B) of the new gas valve assembly and note this down.

Installing the gas valve assembly

6. Insert the gas valve assembly. When doing so, replace all of the seals.
7. Use both screws to fasten the gas valve assembly onto the fan.
8. Screw the union nut onto the gas valve assembly with a new seal. In the process, secure the gas pipe against twisting. Tightening torque, see appendix.
9. Plug in both of the gas valve assembly's plugs.
10. Check the gas valve assembly and the connections for tightness. (→ Section 9.17)
11. Install the front casing. (→ Section 7.11)

12. If the offset that you read has five digits, set diagnostics code **D.052** using the first three digits. (→ Section 8.3)
13. If the offset that you read has three digits, set diagnostics code **D.052**. (→ Section 8.3)
14. If the product is set with liquefied petroleum gas as the gas type and the offset that you read has five digits, set diagnostics code **D.182** using the last two digits. (→ Section 8.3)
15. Exit the menu level. (→ Section 8.8)
16. Check the O₂ content. (→ Section 9.13.4)

13.7.8 Replacing the heat exchanger

1. Remove the connector for the air/flue pipe. (→ Section 7.2.6.1)
2. Remove the side casing. (→ Section 13.7.2)
3. Remove the compact thermal module. (→ Section 12.7.1)

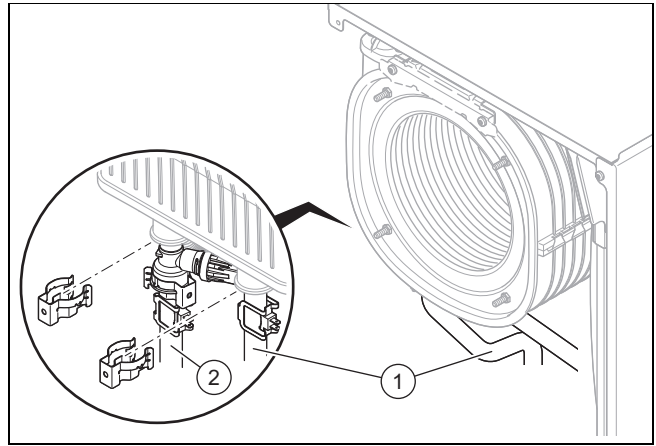

4. Remove the clips from the flow pipe (2) and the return pipe (1).
5. Loosen the pipes for the flow/return on the heat exchanger.

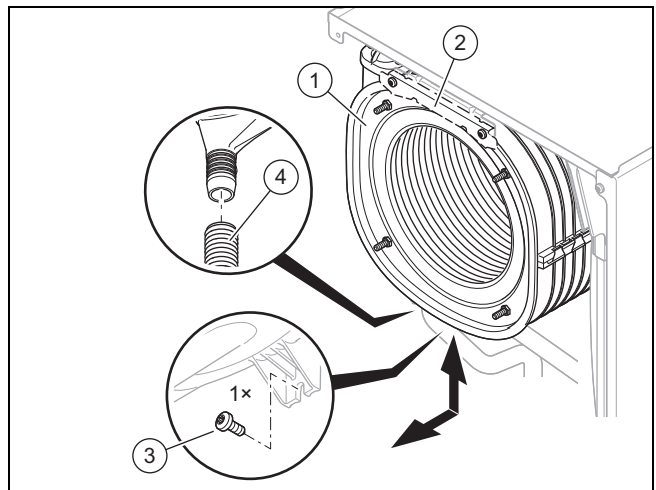

6. Remove the condensate discharge hose (4) from the heat exchanger (1).
7. If a front retainer (2) is available, remove the two screws from the retainer and remove the retainer.
8. Remove the screw (3) from the underside of the heat exchanger.
9. Pull the heat exchanger out to the front and downwards diagonally.

10. Insert the new heat exchanger into the grooves on the back panel.
11. Screw in a new screw tightly on the underside of the heat exchanger.
12. If you have removed an existing front retainer, use two screws each to screw the retainer in tightly.
13. Secure the condensate discharge hose on the heat exchanger.
14. Insert the flow/return pipes into the heat exchanger as far as they will go. When doing so, replace all of the seals.
15. Secure the clips to the flow/return pipe.
16. Install the compact thermal module. (→ Section 12.7.2)
17. Install the side casing. (→ Section 13.7.16)
18. Install the connector for the air/flue pipe. (→ Section 7.2.6.2)
19. Fill the heating installation. (→ Section 9.9)
20. Purge the heating installation. (→ Section 9.10)

13.7.9 Replacing the expansion vessel

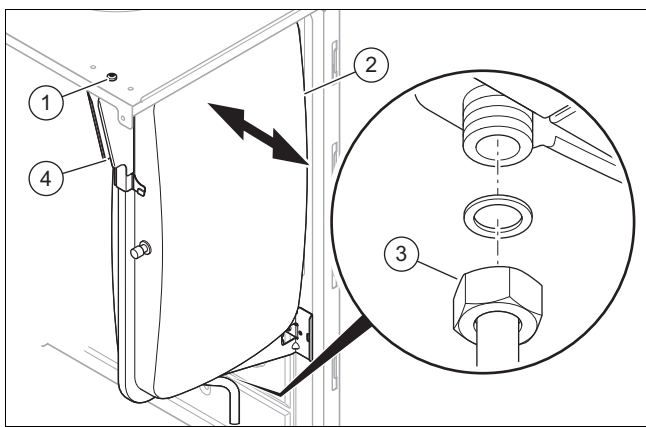

1. Undo the nut (3).
2. Undo the screw (1) on the support plate (4) and remove the support plate.
3. Pull out the expansion vessel (2) to the side.
4. Insert the new expansion vessel into the product.
5. Screw in the nuts below the expansion vessel tightly. Use a new seal for this.
6. Use the screw to secure the support plate.
7. Fill the heating installation. (→ Section 9.9)
8. Purge the heating installation. (→ Section 9.10)

13.7.10 Replace the display



Note

Spare parts must only be used once.

If you only replace the display, when the product is switched on, the new display adopts the parameters that were previously set from the PCB that was not replaced. After replacing the display assembly, the **DSN code** (Device Specific Number) is transferred to the respective replaced assembly and is written to its memory, where it cannot be deleted.

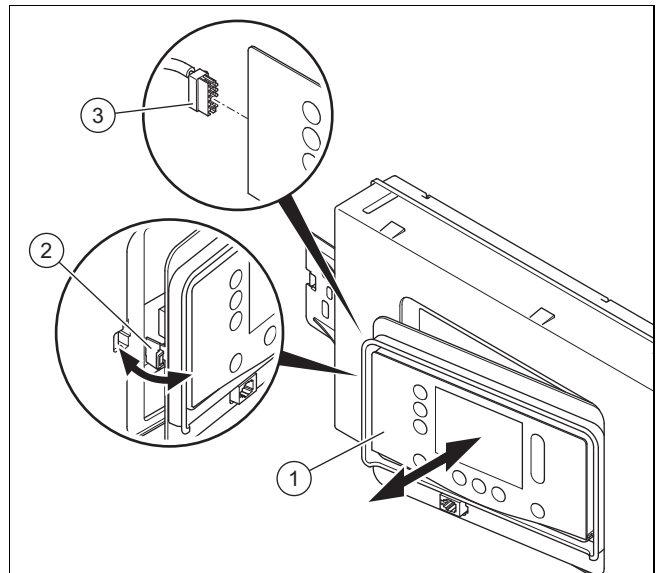

1. Release the display (1) from the retainer (2) on the left-hand side.
2. Remove the plug (3) from the display.
3. Replace the display.
4. Plug the plug into the new display.
5. Install the display in the retainer.
6. Establish the power supply.
 - ◀ The **DSN code** is transferred from the PCB to the display.

13.7.11 Replacing the PCB



Note

Spare parts must only be used once.

If fault **F.064** is present, check diagnostics code **D.166** before you replace the PCB.

If you only replace the PCB, when the product is switched on, the new PCB adopts the parameters that were previously set from the display that was not replaced. After replacing the PCB assembly, the **DSN code** (Device Specific Number) is transferred to the respective replaced assembly and is written to its memory, where it cannot be deleted.

1. Open the electronics box. (→ Section 7.10.3)
2. Replace the PCB in accordance with the set-up and installation instructions supplied.
3. Close the electronics box. (→ Section 7.10.4)
4. Establish the power supply.
 - ◀ The **DSN code** is transferred from the display to the PCB.

13.7.12 Replacing the PCB and the display



Note

Spare parts must only be used once.

After replacing the display and PCB assemblies, all of the installation-specific settings are deleted.

If required, use the installation-specific settings from the "Diagnostics codes" table in the appendix if they have been noted there. (→ Appendix D)

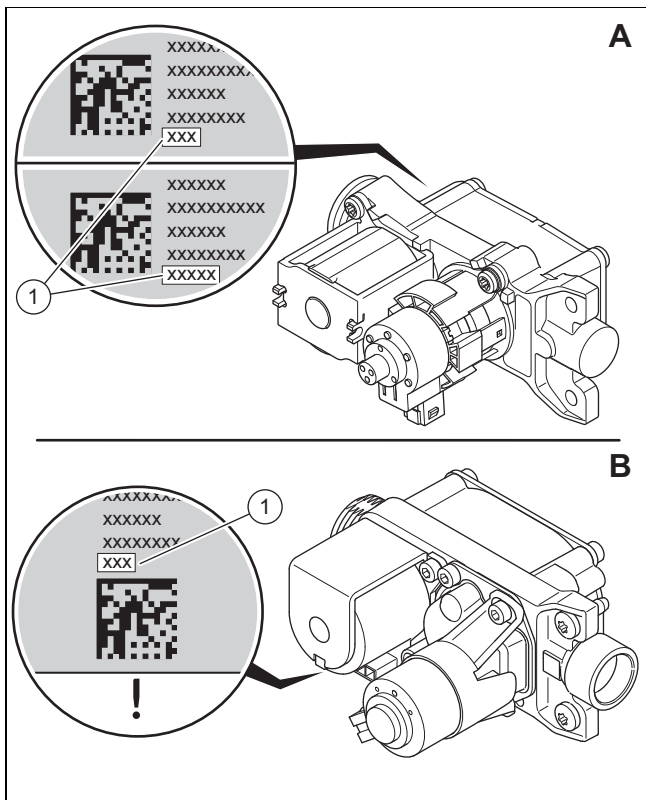

1. Read the offset (1) that is printed on the rear (type A) or underside (type B) of the gas valve assembly and note this down. Use a mirror, for example.

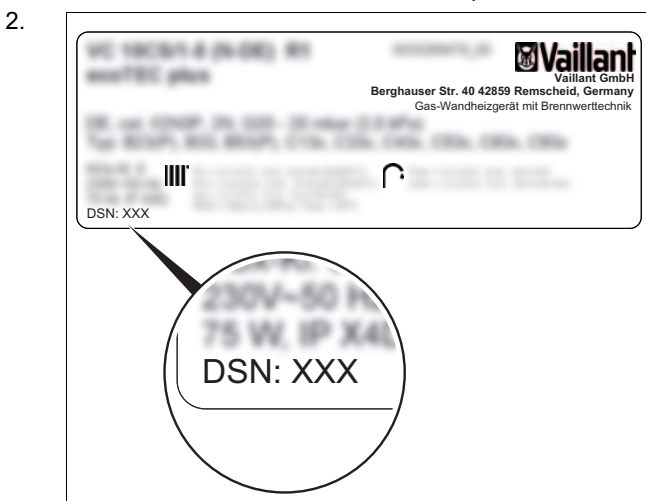

Read the **DSN-Code** (Device Specific Number) from the data plate on the rear of the electronics box and note this down.

3. Open the electronics box. (→ Section 7.10.3)
4. Replace the PCB and display according to the set-up and installation instructions supplied; this is best done one after the other. Doing so in this way means that the old PCB can transfer the saved values to the new display or, alternatively, the old display can transfer the saved values to the new PCB.
5. Close the electronics box. (→ Section 7.10.4)
6. Replace the control electrode. (→ Section 13.7.14)
7. Install the front casing. (→ Section 7.11)
8. Establish the power supply.
9. ◁ After switching on, the product switches directly to the menu to select the language.
10. Select the required language.

11. Set the read-off value **DSN code** (via **D.093**) for the product type. (→ Section 8.3)
 - ◁ The electronics are now set to the product type and the parameters of all diagnostics codes are set to factory settings.
 - ◁ The installation assistant starts.
12. If the gas valve assembly offset that you read has five digits, set diagnostics code **D.052** using the first three digits. (→ Section 8.3)
13. If the gas valve assembly offset that you read has three digits, set diagnostics code **D.052**. (→ Section 8.3)
14. If the product is set with liquefied petroleum gas as the gas type and the gas valve assembly offset that you read has five digits, set diagnostics code **D.182** using the last two digits. (→ Section 8.3)
15. Check the installation-specific settings and adjust these.
16. Start the test operation in chimney sweep mode by pressing .

13.7.13 Replacing the ignition electrode



Danger!

Risk of death from hot flue gases!

Seals, screws and insulation on the control electrode and combustion chamber must not be damaged.

- ▶ Avoid damaging the burner insulating mat on the back panel of the combustion chamber cover.
- ▶ Replace the burner insulating mat as soon as it shows signs of damage.
- ▶ Replace the seal and screws each time you replace the control electrode.

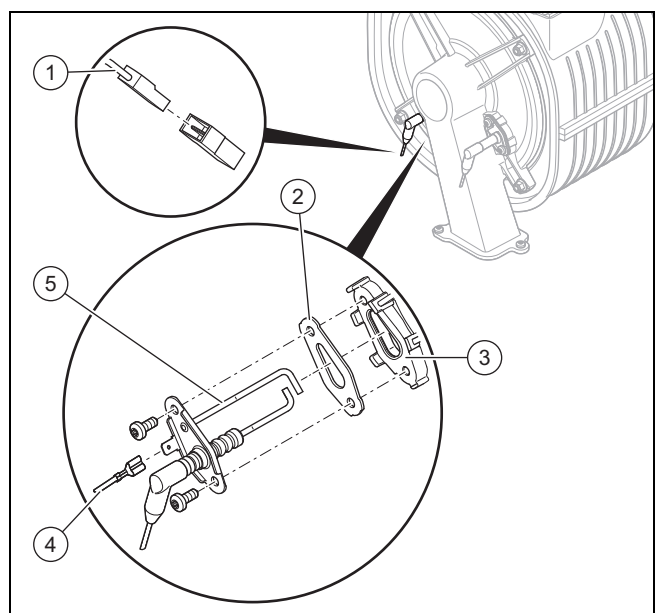

1. Remove the earth cable (4).
2. Remove the plug (1) for the ignition electrode's cable.
3. Unscrew both screws.
4. Thread the ignition electrode (5) carefully out of the burner flange (3). Ensure that you do not damage the

burner insulating mat on the rear of the combustion chamber cover.

5. Remove the sealing residue from the burner flange.



Caution.

Risk of material damage caused by touching and cleaning.

The electrode may emit incorrect signals due to changes in the surface.

- ▶ Only touch an electrode at the ceramic section.
- ▶ Never clean an electrode.

6. Insert the new ignition electrode with a new seal (2).
7. Use two new screws to screw the ignition electrode in tightly. Tightening torque, see appendix.
8. Reconnect the plug for the ignition electrode's ignition line.
9. Reconnect the plug on the earth cable.

13.7.14 Replacing the control electrode



Danger!

Risk of death from hot flue gases!

Seals, screws and insulation on the control electrode and combustion chamber must not be damaged.

- ▶ Avoid damaging the burner insulating mat on the back panel of the combustion chamber cover.
- ▶ Replace the burner insulating mat as soon as it shows signs of damage.
- ▶ Replace the seal and screws each time you replace the control electrode.

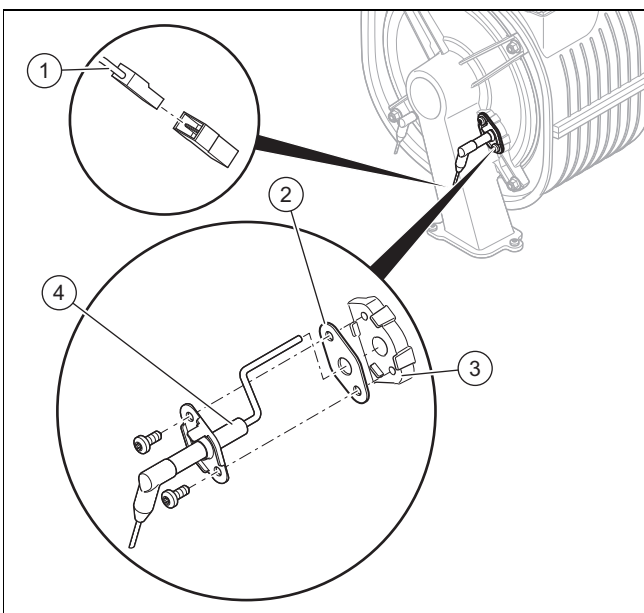

1. Remove the plug (1) for the control electrode's cable.
2. Unscrew both screws.
3. Thread the control electrode (4) carefully out of the burner flange (3). Ensure that you do not damage the burner insulating mat on the rear of the combustion chamber cover.

4. Remove the sealing residue from the burner flange.



Caution.

Risk of material damage caused by touching and cleaning.

The electrode may emit incorrect signals due to changes in the surface.

- ▶ Only touch an electrode at the ceramic section.
- ▶ Never clean an electrode.

5. Insert the new control electrode with a new seal (2).
6. Use two new screws to screw the control electrode in tightly. Tightening torque, see appendix.
7. Reconnect the plug for the control electrode's ignition line.
8. Install the front casing. (→ Section 7.11)
9. Open the gas stopcock.
10. Connect the product to the power supply.
11. Activate diagnostics code **D.147** via **D.146**. (→ Section 8.3)
12. Set diagnostics code **D.147** to **New electrode** (→ Section 8.3).
13. Check the O₂ content. (→ Section 9.13.4)

13.7.15 Routing wiring harnesses



Note

High temperatures may damage wiring harnesses.

Incorrect routing of the wiring harnesses may lead to electromagnetic faults.

To prevent damage and faults, install the wiring harnesses as shown in the figure.

Validity: VU 10CS/1-5 (N-GB) ecoTEC plus 610 OR VU 15CS/1-5 (N-GB) ecoTEC plus 615 OR VU 20CS/1-5 (N-GB) ecoTEC plus 620 OR VU 25CS/1-5 (N-GB) ecoTEC plus 625 OR VU 30CS/1-5 (N-GB) ecoTEC plus 630 OR VUW 20/26CS/1-5 (N-GB) ecoTEC plus 826 OR VUW 25/32CS/1-5 (N-GB) ecoTEC plus 832 OR VUW 30/36CS/1-5 (N-GB) ecoTEC plus 836

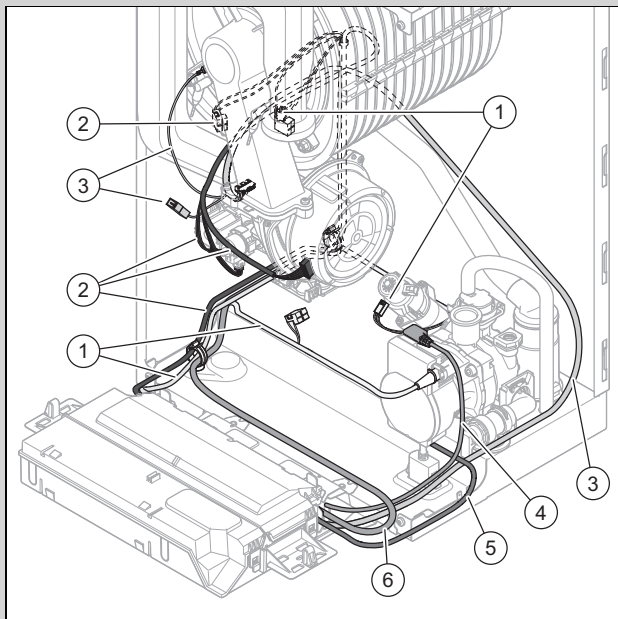

- | | | | |
|---|--|---|----------------------------|
| 1 | Hydraulics wiring harness (impeller water flow sensor, water pressure sensor, prioritising diverter valve) | 3 | Ignition wiring harness |
| 2 | Wiring harness (fan, gas valve assembly, temperature sensors) | 4 | High-efficiency pump cable |
| | | 5 | Socket cable |
| | | 6 | Power supply cable |

Validity: VU 35CS/1-5 (N-GB) ecoTEC plus 635 OR VUW 30/40CS/1-5 (N-GB) ecoTEC plus 840

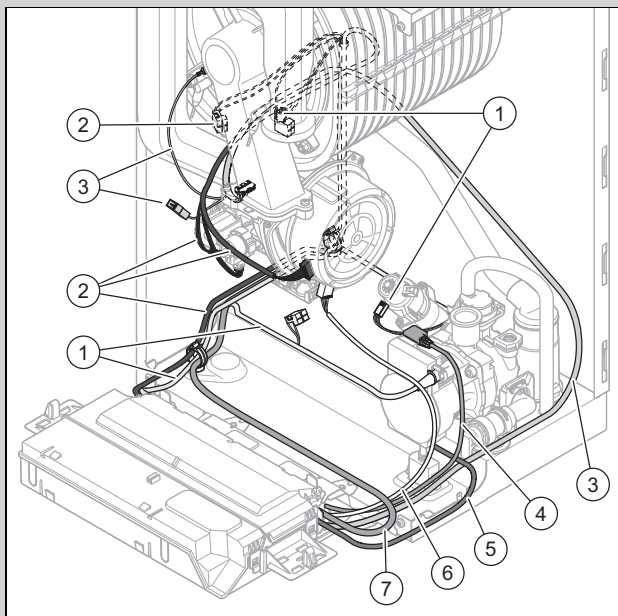

- | | | | |
|---|--|---|---|
| 1 | Hydraulics wiring harness (impeller water flow sensor, water pressure sensor, prioritising diverter valve) | 2 | Wiring harness (fan, gas valve assembly, temperature sensors) |
| | | 3 | Ignition wiring harness |
| | | 4 | High-efficiency pump cable |

- | | | | |
|---|---------------------|---|--------------------|
| 5 | Socket cable | 7 | Power supply cable |
| 6 | Cable for 230 V fan | | |

1. Install the wiring harnesses as shown in the figure.
2. When plugging in the plug, observe the colour coding.

13.7.16 Completing repair work

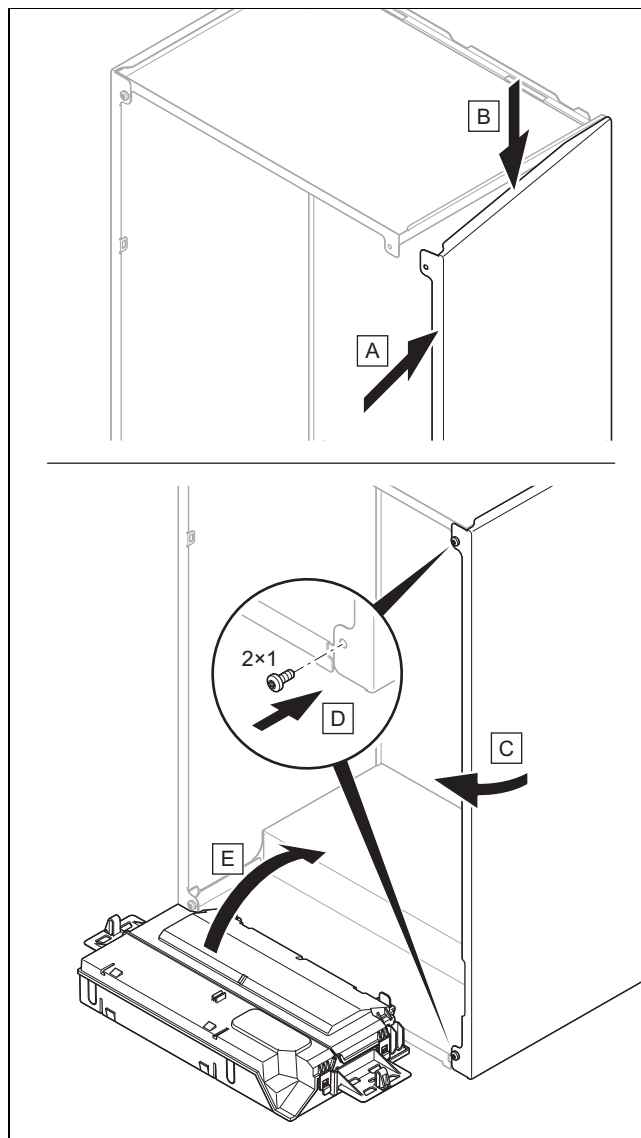

1. If you have removed the side casing, install it as shown in the figure.
2. Use two new screws to screw the side casing in tightly.
3. Open all service valves and the gas stopcock if this has not yet been done.
4. Check the product for tightness. (→ Section 9.17)
5. Install the front casing. (→ Section 7.11)
6. If required, install the front panel below the display.
7. If required, install the modules below the product (→ Module installation instructions).
8. Establish the power supply if this has not yet been done.
9. Switch the product back on if this has not yet been done. (→ Section 9.4)

14 Decommissioning

14.1 Activate the standby mode

- ▶ Press  briefly.
 - ◁ The display goes out. The standby button continues to light up.
 - ◁ All heat demands are blocked, however the frost protection is active for the heating installation.
 - ◁ A heat demand via the frost protection function activates the product. The product then goes back into standby mode.
 - ◁ If a fault occurs that blocks the operation, this is shown on the display.

14.2 Temporarily decommissioning

1. Press  briefly.
 - ◁ The display goes out.
2. Switch off the product at the switched fused spur box.
 - ◁ The frost protection function is deactivated.
3. Close the gas stopcock.
4. On products with a connected domestic hot water cylinder, you must also close the cold-water isolation valve.

14.3 Permanently decommissioning

1. Drain the product. (→ Section 12.9)
2. Press  briefly.
 - ◁ The display goes out.
3. Completely disconnect the product from the power supply and close all of the supply pipes to the product (gas, water).
4. Check that the 230 V voltage is no longer present in the product.

15 Disposing of the packaging

- ▶ Dispose of the packaging correctly.
- ▶ Observe all relevant regulations.
- ▶ For detailed information refer to www.vaillant.co.uk.

Appendix

A Tightening torques

Manufacturer's recommendation for the tightening torques

Component	Value	Unit
Gas valve assembly, union nut	40	Nm
	15	Nm + Degrees
	60	
Burner, fixing screws	6	Nm
Fan flange, mixture pipe screws	5.5	Nm
Fan, gas valve assembly screws	5.5	Nm
Gas valve assembly, test nipple screw plug	0.9	Nm
Gas isolation valve, test nipple screw plug	1	Nm
Ignition electrode, fixing screws	3	Nm
Control electrode, fixing screws		
Pump head, fixing screws	5	Nm

B Inspection and maintenance work

The table below lists the manufacturer requirements with respect to minimum inspection and maintenance intervals. If national regulations and directives require shorter inspection and maintenance intervals, you should observe these instead of the intervals listed. Each time inspection and maintenance work is carried out, carry out the required preparatory and completion work.



Note

The country-specific specification for the maximum CO content has a higher value. With regard to the measured CO content, first check the country-specific regulations before starting any measures.

As part of a combustion check that is carried out, (→ Section 9.13.4) a CO content of > 350 ppm undiluted is determined.

- ▶ Check the permissible total pipe length as well as the diameter of the air/flue system in accordance with the enclosed valid set-up instructions for air/flue systems.
- ▶ Check whether the air/flue system has been installed correctly.
- ▶ Check whether the air/flue system is blocked and/or damaged.

The check was not completed with the result that the determined CO content is > 350 ppm.

- ▶ Replace the control electrode. (→ Section 13.7.14)

The control electrode has been replaced and the CO content is still > 350 ppm.

- ▶ Check the combustion chamber. (→ Section 12.8.2)

The combustion chamber has been inspected and the CO content is still > 350 ppm.

- ▶ Contact customer service.

#	Maintenance work	Interval	
1	Record all of the analysis results in the Benchmark Checklist in these instructions	Annually	
2	Ask the end user whether any significant problems occur when operating the product	Annually	
3	Use the diagnostics system to check the product's fault history	Annually	
4	Visually inspect whether the air/flue pipe and its opening have been installed correctly in accordance with the set-up instructions	Annually	
5	Check that the unit has been installed correctly and the connections have been secured	Annually	

#	Maintenance work	Interval	
6	Check that the condensate pipe is in good condition, that it is leak-tight and that the drain is correct	Annually	
7	Check whether all of the externally routed condensate pipes are dimensioned correctly and have been insulated sufficiently (frost protection)	Annually	
8	Check whether the gas flow rate corresponds with the specifications on the data plate and lies within the tolerances specified in these instructions	Annually	
9	If the gas flow rate lies outside of the tolerances specified in these instructions, eliminate the fault in accordance with the regulations and the current technology	Annually	
10	Check the general condition of the product and, if required, eliminate any faults that are found	Annually	
11	Checking the control electrode using the O ₂ content	Annually	
12	Carry out the combustion analysis: Measure the CO content, O ₂ content and the CO/O ₂ ratio.	Annually	
13	Check the product's recirculation at the supply air test point on the air/flue pipe. If required, inspect the entire air/flue system and, if necessary, correct the fault	Annually	
14	Disconnect the product from the electrical installation	Annually	
15	Check and, if required, correct the electrical installation	Annually	
16	Removing dirt from the product and the vacuum chamber	Annually	
17	Visually checking the condition of the heat cell, checking for corrosion, rust or damage	Annually	
18	Check that the gas isolator cock and service valves function correctly	Annually	
19	Check the quality of the heating water: Clarity (clouding), correct inhibitor and pH value	Annually	
20	Removing the compact thermal module	At regular intervals	55
21	Check the burner for damage	At regular intervals	
22	Replacing the control electrode	If required, at least every 5 years or 20,000 operating hours (whichever comes first)	66
23	Checking the insulating mats in the combustion area and replacing damaged insulating mats	At regular intervals	
24	Cleaning the heat exchanger	At regular intervals	57
25	Cleaning the condensate siphon	Annually	57
26	Filling the condensate siphon	Annually	44
27	Installing the compact thermal module	At regular intervals	56
28	Checking and, if required, supplementing the pre-charge pressure for the internal expansion vessel	At regular intervals	57
29	Validity: Product with integrated hot water generation Cleaning the strainer in the cold water inlet	At regular intervals	58
30	Validity: Product with integrated hot water generation Check the impeller sensor for dirt/damage	At regular intervals	
31	Validity: Product with integrated hot water generation If the water volume is insufficient (domestic hot water) or the outlet temperature is insufficient, check the secondary heat exchanger	At regular intervals	
32	Reassemble the product	After each time maintenance work is carried out	
33	Opening the service valves	Annually	
34	Filling the heating installation	At regular intervals	43
35	Run the test operation on the product/heating installation including hot water generation (if available) and, if required, purge the product/heating installation	Annually	
36	Cleaning the protection kit, if available	Annually	
37	Completing inspection and maintenance work	Annually	59
38	Re-checking the O ₂ content (the air ratio)	If required, at least every 2 years	
39	Check the product for gas, flue gas, water and condensate leaks	Annually	

C Installer level



Note

Since the code table is used for various products, some codes or some steps may not be visible in the installation assistant.

Setting level	Values		Unit	Increment, select, explanation	Factory setting
	Min.	Max.			
Enter access code	00	99		1 (competent person code 17)	
Data overview	Current value				
Installation assistant					
→ Language:				Languages available for selection	Country-specific
→ Date:				Current date	
→ Time:				Current time	
→ Device Specific Number (DSN)	0	250		Setting the Device Specific Number (only displayed in a double part replacement scenario for the display and PCB)	
→ Fill the installation with water				Check the filling pressure and, if required, top up the heating installation.	
→ Hydraulic operating mode	0	4		0: Without bypass, Δp-const. 1: W/o bypass, Δp-const.,kick 2: Bypass, Δp-const. 3: Spread ΔT 4: Fixed pump stage	*
→ Adjust the available pressure			mbar	This selection depends on the setting Hydraulic operating mode .	
→ Spread setting			K	This selection depends on the setting Hydraulic operating mode .	
→ Pump stage setting			%	This selection depends on the setting Hydraulic operating mode .	
→ Gas type selection				0: Not selected 1: Natural gas 2: Propane 30/37 mbar 3: Special gas FR 4: Special gas GB 5: Special gas IT 6: Propane 50 mbar 7: Ls gas Only the selection for the product in question is shown here. If your product can be converted to liquefied petroleum gas and liquefied petroleum gas is selected, the corresponding stickers must be affixed. (→ Section 9.18)	
→ Single flue installation				Adjustment takes place automatically after the selection is made. Product-dependent	
→ Weather-comp. control system				0: Deactivated 1: Activated This function must be activated if an outdoor temperature sensor is installed and there is no room temperature control.	
→ Installer contact info				Company, Phone number	
QR service code				This is where you can use the Service App's QR code scanner to read important unit data.	
Check programmes					
→ P.000 - P.008	Current value			You can find more detailed information in the table of check programmes.	
Actuator test					
* Select the optimum operating point for the on-site installation.					

Setting level	Values		Unit	Increment, select, explanation	Factory setting
	Min.	Max.			
→ T.001 - T.007	Current value			You can find more detailed information in the table of actuator tests.	
Diagnostics codes					
→ D.XXX - D.XXX	Current value			You can find more detailed information in the table of diagnostics codes.	
Fault history					
→ F.XXX - F.XXX	Current value			Fault codes are only displayed and can only be deleted if faults have occurred. You can find more detailed information in the table of fault codes.	
Limp home mode history					
→ L.XXX - L.XXX → N.XXX - N.XXX	Current value			Reversible codes Irreversible codes You can find more detailed information in the table of LHM codes.	
Maintenance codes					
→ I.XXX - I.XXX	Current value			You can find more detailed information in the table of maintenance codes.	
Factory settings?				No, Yes	
Installation configuration (can only be selected if a control module is installed)					
→ Status:				S.XXX	
→ Heating	Current value		°C	Target flow temp.:	
	Current value		°C	Actual flow temperature:	
	10	99	°C	OT switch-off threshold:	20
	0.10	4.00		Heat curve:	1.2
	30	80	°C	Min. target flow temp.:	30
	40	80	°C	Max. target flow temp.:	40
				Set-back mode: Eco, Reduced	Reduced
→ DHW				Circ. pump: Off, On	Off
				Anti-legio. day: Off, Daily, Day of the week	Off
				Anti-legio. time:	
→ Screed drying profiles	0	90	°C	Display and set the target flow temperature for Day 1 to 29.	
Screed drying (can only be selected if a control module is installed)				Activates screed drying for freshly laid screed in accordance with the settings under Screed drying profiles . Drying day: Screed-drying temp.: °C	
* Select the optimum operating point for the on-site installation.					

D Diagnostics codes



Note

Since the code table is used for various products, some codes may not be visible or cannot be set for the product in question.

Diagnostics code	Values		Unit	Increment, select, explanation	Setting	
	Min.	Max.			Factory	Current
D.000 Maximum load in heating mode	Product-dependent		kW	Adjustable partial heat load: The adjustment range can be viewed in the technical data. Not all products have an adjustment range. Auto: Product automatically adjusts the max. partial heat load to the current system demand.	Auto	
D.001 Heating pump overrun time	1	60	min	1 Overrun time of internal heating pump for heating mode	5	
D.002 Maximum burner anti-cycling time	2	60	min	1 Maximum heating burner anti-cycling time at 20 °C flow temperature	20	
D.003 Domestic hot water temperature, actual value	Current value		°C	1		
D.004 Domestic hot water cylinder temperature	Current value		°C	Measured value for the cylinder temperature sensor.		
D.005 Target heating flow temperature value	Current value		°C	The maximum value that is set in D.071 and is restricted by means of an eBUS control (if connected).		
D.006 Domestic hot water temperature target value	Current value		°C		35	
D.008 Room thermostat status (230V)				Off, On		
D.009 Target value for the eBUS control	Current value			Displayed if a control is connected.		
D.010 Status of the heating pump	Current value			Off, On		
D.011 Status of the external pump	Current value			Off, On		
D.012 Status of cylinder charging pump	Current value			Off, On		
D.013 Status of circulation pump	Current value			Off, On		
D.015 Actual pump speed	Current value		%			
D.016 Room thermostat status (24V)	Current value			Off, On		
D.017 Heating control type				Flow temperature control Return temp. control (If you have activated the return temperature control, the automatic heat output determination function is not active.)	Flow temperature control	
D.018 Heating pump operating mode				Permanent (pump runs while there is a demand from the room thermostat) Eco (pump runs intermittently after burner operation. Pump cycle: 5 minutes on/25 minutes off.)	Eco	
D.020 Setting the max. domestic hot water temperature	50	70	°C	1 Only products with domestic hot water generation	70 (Boiler) 65 (Combi boiler)	
D.021 Status of warm start for DHW	Current value			Off, On		
D.022 Status of DHW demand	Current value			Off, On		

Diagnostics code	Values		Unit	Increment, select, explanation	Setting	
	Min.	Max.			Factory	Current
D.023 Status of the heat demand	Current value			Off, On		
D.025 Status of the eBUS control's domestic hot water demand	Current value			Off, On (Displayed if a control is connected.)		
D.026 Function of internal additional relay D.027 Function of ext. accessory relay 1 D.028 Function of ext. accessory relay 2	1	9		1: Circulation pump 2: External pump 3: Cylinder charging pump 4: Extraction hood 5: External solenoid valve 6: External fault message 8: eBUS remote control 9: Anti-legionella pump 10: Solar cyl. bypass valve	2	
D.029 Heating circuit flow rate	Current value		l/h	Current flow rate quantity via the water flow sensor		
D.031 Automatic filling device	Current value			1. Semi-automatic 2. Automatic		
D.033 Target fan speed value	Current value		rpm			
D.034 Actual fan speed value	Current value		rpm			
D.035 3-port valve position	Current value		%	0: Heating position 1: Mid-position (centre position) 2: DHW	1	
D.036 Domestic hot water circuit flow rate	Current value		l/min	Current flow rate quantity via the water flow sensor impeller		
D.039 Cold water temperature, actual value	Current value		°C	Domestic hot water inlet temperature		
D.040 Flow temperature actual value	Current value		°C			
D.041 Return temperature actual value	Current value		°C			
D.043 Heat curve	0.1	4.0		0.05	1.2	
D.045 Heat curve offset	5	30	°C	1	21	
D.047 Outdoor temperature	Current value		°C	Only in conjunction with an outdoor temperature sensor.		
D.052 Offset: Gas valve stepper motor	101	183		Valid for the first 3 digits of the 3- or 5-digit offset. The offset is specified on the rear or underside of the gas valve assembly.	Product-dependent	
	20	70		Valid for the last 2 digits of the 3-digit offset. The offset is specified on the rear or underside of the gas valve assembly.	Product-dependent	

Diagnostics code	Values		Unit	Increment, select, explanation	Setting	
	Min.	Max.			Factory	Current
D.058 Solar circuit post-heating	3	5		3: Min. target DHW val. 60 °C 5: Auto Outlet temperature 40 °C: <ul style="list-style-type: none"> – At an inlet temperature ≤ 35 °C, the heat generator starts in order to reach the set outlet temperature. – At an inlet temperature > 35 °C, the heat generator stops or does not start. If the inlet temperature is < 30 °C, the heat generator starts again. Outlet temperature 60 °C: <ul style="list-style-type: none"> – At an inlet temperature ≤ 55 °C, the heat generator starts in order to reach the set outlet temperature. – At an inlet temperature > 55 °C, the heat generator stops or does not start. If the inlet temperature is < 50 °C, the heat generator starts again. Only for products with integrated domestic hot water generation.	5	
D.060 Number of overheating faults	Current value					
D.061 Number of ignition faults	Current value					
D.062 Night set-back	0	30	°C	1	0	
D.064 Average ignition time	Current value		s			
D.065 Maximum ignition time	Current value		s			
D.066 Warm start activation				Warm start deactivated Warm start activated	Product-dependent	
D.067 Remaining burner anti-cycling time	Current value		min			
D.068 Number of unsuccessful ignitions at 1st attempt	Current value					
D.069 Number of unsuccessful ignitions at 2nd attempt	Current value					
D.070 3-port valve setting	0	2		0: Auto 2: Heating position Only for products without integrated domestic hot water generation.	0	
D.071 Maximum target flow temperature	40	80	°C	1	75	
D.072 Pump overrun after cylinder charging	0	10	min	Internal pump	2	
D.073 Offset: Target warm start value	-15	5	K	1	0	
D.074 Anti-legionella function with integrated cylinder				Off, On	On	
D.075 Maximum duration of the cylinder charging	20	90	min	1	45	

Diagnostics code	Values		Unit	Increment, select, explanation	Setting	
	Min.	Max.			Factory	Current
D.077 Maximum load in domestic hot water mode	Output-dependent		kW	1	Max. load	
D.078 Maximum target flow temperature value for domestic hot water	50	80	°C	1 Note The chosen value must be at least 15 K or 15 °C above the set target cylinder value.	75	
D.080 Operating hours, heating	Current value		h			
D.081 DHW operating hours	Current value		h			
D.082 Burner starts in heating mode	Current value					
D.083 DHW burner starts	Current value					
D.084 Operating hours until service	„- - -“	7000	h	1 "- - -" = Deactivated	5000	
D.085 Minimum load for the unit	Output-dependent		kW	1	Min. load	
D.088 Minimum domestic hot water flow rate	Current value			1.5 l/min (no delay) 3.7 l/min (2 s delay)		
D.090 eBUS control				Not recognised Recognised		
D.091 Status of the DCF connection				No reception Data reception Synchronised Valid		
D.092 Shift-load cylinder				Not connected Communication fault Connection active		
D.093 Device Specific Number (DSN)	Current value				Product-dependent	
D.094 Delete fault history				No, Yes		
D.095 Software versions	Current value					
D.096 Factory settings?				No, Yes		
D.098 Coding resistor value				Coding resistor 1 Coding resistor 3		
D.124 Smart ECO, current status	Current value					
D.125 Domestic hot water cylinder outlet temperature	Current value		°C			
D.128 Minimum heating target flow temperature	Current value		°C		40	
D.129 Minimum domestic hot water target value	Current value		°C		40	

Diagnostics code	Values		Unit	Increment, select, explanation	Setting	
	Min.	Max.			Factory	Current
D.145 Deactivate detection: Air/flue pipe blocked	Current value			<p>Diagnostics code for deactivating the check of the flue gas blockage.</p> <p>Only use this diagnostics code if the product displays fault code F.035 during the initial start-up.</p> <p>After the air/flue pipe has been checked and any blockage has been removed, the check of the flue gas blockage must be deactivated via D.145.</p>		
D.146 Enable control electrode replacement				No, Yes		
D.147 Replace control electrode				<p>No</p> <p>New electrode (New electrode can only be selected if D.146 is enabled)</p>		
D.156 Enable gas conversion				Enable gas conversion; gas type selected		
D.157 Gas type selection				<p>0: Not selected</p> <p>1: Natural gas</p> <p>2: Propane 30/37 mbar</p> <p>3: Special gas FR</p> <p>4: Special gas GB</p> <p>5: Special gas IT</p> <p>6: Propane 50 mbar</p> <p>7: Ls gas</p> <p>Only the selection for the product in question is shown here.</p>	Product-dependent	
D.158 Gas-air ratio setting	0	-5		<p>0: Standard value</p> <p>-1: Weakening 1</p> <p>-2: Weakening 2</p> <p>-3: Weakening 3</p> <p>-4: Weakening 4</p> <p>-5: Weakening 5</p> <p>For natural gas operation only.</p>	0	
D.159 Switching procedure anti-cycl. time				<p>Deactivated, Activated</p> <p>Switching procedure anti-cycling time between domestic hot water and heating mode.</p>	Activated	
D.160 Target water pressure value	1.0	2.0	bar	0.1 Product-dependent	1.5	
D.161 Service date	Current value				Current date + one year	
D.162 Weather-compensated control system				<p>0: Deactivated</p> <p>1: Activated</p> <p>Only applies if an outdoor temperature sensor is installed but there is no room temperature control.</p> <p>Product-dependent</p>	1	
D.163 Function of int. accessory relay 2				<p>1: Circulation pump</p> <p>11: Automatic filling device</p> <p>On products with an automatic filling device, the factory setting is 11.</p>	Product-dependent	
D.164 Flue installation with single-flue configuration	-5	5		To compensate for the pressure losses through the air/flue pipe, a setting is required in the installation assistant (country-specific) or the diagnostics code D.164 .	0	

Diagnostics code	Values		Unit	Increment, select, explanation	Setting	
	Min.	Max.			Factory	Current
D.166 ADC fault index	0	20		1: Check the flow temperature sensor 2: Check the return temperature sensor 5: Check the heat cell coding resistor 6: Check the control electrode 7–8: Check the ignition electrode 9: Check the DHW inlet temperature sensor 15: Check the fan coding resistor 17, 19, 20: Check the control electrode		
D.167 Cylinder connection	0	1		0: Cylinder not connected 1: Cylinder connected	0	
D.170 Hydraulic operating mode	0	4		0: Without bypass, Δp-const. 1: W/o bypass, Δp-const.,kick 2: Bypass, Δp-const. 3: Spread ΔT 4: Fixed pump stage The diagnostics codes D.171 - D.175 refer to the selection in D.170 .	Product-dependent	
D.171 Target pressure level value	100	400	mbar	Valid for Without bypass, Δp-const., W/o bypass, Δp-const.,kick and Bypass, Δp-const..	200	
D.172 Target spread value	Current value		K	Valid for Spread ΔT .	20	
D.173 Minimum pressure level	Current value		mbar	Valid for Spread ΔT .	100	
D.174 Maximum pressure level	Current value		mbar	Valid for W/o bypass, Δp-const.,kick, Bypass, Δp-const. and Spread ΔT .	400	
D.175 Pump stage	Current value		%	10 Valid for Fixed pump stage .	100	
D.182 Offset: Gas valve assy step. motor 2	1	80		Valid for the last two digits of gas valve assemblies with an offset with five digits. The offset is specified on the rear or underside of the gas valve assembly. Valid for products with liquefied petroleum gas set as the gas type.	Product-dependent	
D.185 Configuration type setting	0	1		0: Single-flue configuration 1: Multiple-flue configuration Multiple-flue configuration can only be selected if D.187 is enabled.	0	
D.186 Multiple-flue system diagram	0	5		0: Not selected 1: Basic diagram 1 2: Basic diagram 2 3: Basic diagram 3 4: Basic diagram 4 5: Basic diagram 5 (Only visible if Multiple-flue configuration is selected under D.185 . Only the selection for the product in question is shown here.)	0	
D.187 Enable flue system config.				Enable flue sys./diag. sel. Flue sys./diagram selected (only visible if the conversion set comprising air intake pipe with integrated non-return valve and air-mass flow sensor is installed)	Product-dependent	

E Status codes



Note

Since the code table is used for various products, some codes may not be visible for the product in question.

Code	Meaning
S.000	There is no demand for heating mode.
S.001	Heating mode is active and the fan is in prerun mode.
S.002	Heating mode is active and the heating pump is in prerun mode.
S.003	Heating mode is active and the unit ignites.
S.004	Heating mode is active and the burner is operating.
S.005	Heating mode is active and the heating pump and fan are in overrun mode.
S.006	Heating mode is active and the fan is in overrun mode.
S.007	Heating mode is active and the heating pump is in overrun mode.
S.008	Heating mode is active and the unit is in burner anti-cycling time.
S.009	The heating mode is active and the unit carries out an automatic drift adaptation of the control electrode in order to offset the ageing of the electrode.
S.010	There is no demand for domestic hot water draw-off.
S.011	The domestic hot water draw-off is active and the fan is starting up.
S.012	The domestic hot water draw-off is active and the heating pump is in prerun mode.
S.013	The domestic hot water draw-off is active and the unit ignites.
S.014	The domestic hot water draw-off is active and the burner is operating.
S.015	The domestic hot water draw-off is active and the heating pump and fan are in overrun mode.
S.016	The domestic hot water draw-off is active and the fan is in overrun mode.
S.017	The domestic hot water draw-off is active and the heating pump is in overrun mode.
S.019	Domestic hot water draw-off is active and the unit carries out an automatic drift adaptation of the control electrode in order to offset the ageing of the electrode.
S.020	There is no demand for the domestic hot water cylinder charging.
S.021	The domestic hot water cylinder charging is active and the fan starts.
S.022	The domestic hot water cylinder charging is active and the pump is in prerun mode.
S.023	The domestic hot water cylinder charging is active and the unit ignites.
S.024	The domestic hot water cylinder charging is active and the burner is operating.
S.025	The domestic hot water cylinder charging is active and the pump and fan are in overrun mode.
S.026	The domestic hot water cylinder charging is active and the fan is in overrun mode.
S.027	The domestic hot water cylinder charging is active and the heating pump is in overrun mode.
S.028	The domestic hot water cylinder charging is active and the unit is in burner anti-cycling time.
S.029	The domestic hot water cylinder charging is active and the unit carries out an automatic drift adaptation of the ionisation electrode in order to offset the ageing of the electrode.
S.030	No demand is present for the thermostat. Heating mode is blocked.
S.031	Heating mode has been deactivated and there is no domestic hot water demand.
S.032	The fan is restarted due to an excessive deviation in speed.
S.034	The frost protection function is active.
S.039	The floor surface-mounted thermostat or condensate pump blocks the burner operation. The unit is in a waiting period.
S.041	The water pressure in the heating system is too high.
S.042	An external unit (e.g. condensate pump or external flue non-return flap) is blocking the burner operation. The unit is in a waiting period.
S.054	Due to a water deficiency, the unit is in a waiting period.
S.057	The limp home mode for the combustion regulation blocks the burner operation. The unit is in a waiting period.
S.059	Heat demand available. The circulation water volume is not sufficient for a burner start.
S.088	The purge programme is active.
S.091	The presentation mode is active with limited functionality.

Code	Meaning
S.092	The self-test for the circulation water volume is active.
S.093	A flue gas analysis is not currently possible.
S.096	The self-test for the return temperature sensor is active. The heat demands are blocked.
S.097	The self-test for the water pressure sensor is active. The heat demands are blocked.
S.098	The self-test for the flow and return temperature sensor is active. The heat demands are blocked.
S.109	The standby mode is active.
S.175	The installation assistant is in progress and all demands are blocked.
S.199	The unit is automatically filled with water.
S.326	The hydraulic sensor and actuator test is active.
S.328	The external pump runs continuously and is not connected to the unit.
S.335	Checking whether a flue gas blockage is present.
S.341	The unit temporarily decreases the load to the minimum modulation due to long, permanent burner operation.
S.599	The unit has a fault.

F Fault codes



Note

Since the code table is used for various products, some codes may not be visible for the product in question.



Note

Due to a condensate blockage test after the last ignition attempt, fault messages **F.028**, **F.029** and **F.347** appear after a delay. Wait for the fault displays.

Code/meaning	Possible cause	Measure
F.000 The signal for the flow temperature sensor has been interrupted.	Fault in the electrical connection for the flow temperature sensor	▶ Check and, if required, replace the wiring harness between the PCB and sensor, including all plug connections.
	Flow temperature sensor defective	▶ Check and, if required, replace the flow temperature sensor.
F.001 The signal for the return temperature sensor has been interrupted.	Fault in the electrical connection for the return temperature sensor	▶ Check and, if required, replace the wiring harness between the PCB and sensor, including all plug connections.
	Return temperature sensor defective	▶ Check and, if required, replace the return temperature sensor.
F.002 The signal for the domestic hot water connection temperature sensor has been interrupted.	Fault in the electrical connection for the domestic hot water temperature sensor	▶ Check and, if required, replace the wiring harness between the PCB and sensor, including all plug connections.
	Domestic hot water temperature sensor defective	▶ Check and, if required, replace the domestic hot water temperature sensor.
F.003 The signal for the cylinder temperature sensor has been interrupted.	Fault in the electrical connection for the cylinder temperature sensor	▶ Check and, if required, replace the wiring harness between the PCB and sensor, including all plug connections.
	Cylinder temperature sensor defective	▶ Check and, if required, replace the cylinder temperature sensor.
F.010 The flow temperature sensor has short-circuited.	Fault in the electrical connection for the flow temperature sensor	▶ Check and, if required, replace the wiring harness between the PCB and sensor, including all plug connections.
	Flow temperature sensor defective	▶ Check and, if required, replace the flow temperature sensor.
F.011 The return temperature sensor has short-circuited.	Fault in the electrical connection for the return temperature sensor	▶ Check and, if required, replace the wiring harness between the PCB and sensor, including all plug connections.
	Return temperature sensor defective	▶ Check and, if required, replace the return temperature sensor.
F.012 The domestic hot water connection temperature sensor has short-circuited.	Fault in the electrical connection for the domestic hot water temperature sensor	▶ Check and, if required, replace the wiring harness between the PCB and sensor, including all plug connections.
	Domestic hot water temperature sensor defective	▶ Check and, if required, replace the domestic hot water temperature sensor.

Code/meaning	Possible cause	Measure
F.013 The cylinder temperature sensor has short-circuited.	Fault in the electrical connection for the cylinder temperature sensor	▶ Check and, if required, replace the wiring harness between the PCB and sensor, including all plug connections.
	Cylinder temperature sensor defective	▶ Check and, if required, replace the cylinder temperature sensor.
F.020 The safety cut-out (SCO) interrupts the gas valve control. The gas valve was closed because the temperature of the flow or return temperature sensor has exceeded the maximum limit.	Insufficient/no water in the product.	1. Fill the heating installation. 2. Check the product and the system for leakages.
	Fault in the electrical connection for the flow temperature sensor	▶ Check and, if required, replace the wiring harness between the PCB and sensor, including all plug connections.
	Fault in the electrical connection for the return temperature sensor	▶ Check and, if required, replace the wiring harness between the PCB and sensor, including all plug connections.
	Flow temperature sensor defective	▶ Check and, if required, replace the flow temperature sensor.
	Return temperature sensor defective	▶ Check and, if required, replace the return temperature sensor.
	The pump is defective.	▶ Check and, if required, replace the pump.
	3-port diverter valve defective or blocked	▶ Check and, if required, replace the 3-port diverter valve.
	Water pressure sensor defective	▶ Check and, if required, replace the water pressure sensor.
	Volume flow sensor defective	▶ Check and, if required, replace the volume flow sensor.
	Black discharge via the ignition cable, ignition plug or ignition electrode	▶ Check the ignition cable, ignition plug and ignition electrode.
F.022 No/insufficient water in the product or the water pressure is too low.	Insufficient/no water in the product.	1. Fill the heating installation. 2. Check the product and the system for leakages.
	Fault in the electrical connection for the water pressure sensor	▶ Check and, if required, replace the wiring harness between the PCB and sensor, including all plug connections.
	Cable for the pump/for the water pressure sensor is loose/not connected/defective	▶ Check the cable for the pump/for the water pressure sensor.
	Water pressure sensor defective	▶ Check and, if required, replace the water pressure sensor.
	Pump operation interrupted	▶ Check and, if required, replace the cable to the pump/to the water pressure sensor.
	Solenoid valve for the automatic filling device defective	▶ Check the automatic filling device and replace it, if necessary.
	Internal expansion vessel defective	▶ Check the internal expansion vessel and replace it, if necessary.
F.023 The temperature spread between the flow/return is too great.	Air in the product	▶ Purge the heating installation.
	Fault in the electrical connection for the flow temperature sensor	▶ Check and, if required, replace the wiring harness between the PCB and sensor, including all plug connections.
	Fault in the electrical connection for the return temperature sensor	▶ Check and, if required, replace the wiring harness between the PCB and sensor, including all plug connections.
	Flow temperature sensor defective	▶ Check and, if required, replace the flow temperature sensor.
	Return temperature sensor defective	▶ Check and, if required, replace the return temperature sensor.
	Pump blocked	▶ Check that the pump is working correctly.
	Pump runs with insufficient output	▶ Check that the pump is working correctly.
	3-port diverter valve defective or blocked	▶ Check and, if required, replace the 3-port diverter valve.
	Internal expansion vessel defective	▶ Check the internal expansion vessel and replace it, if necessary.
F.024 The temperature increases too quickly.	Air in the product	▶ Purge the heating installation.
	System pressure too low	▶ Check the system pressure.
	Fault in the electrical connection for the flow temperature sensor	▶ Check and, if required, replace the wiring harness between the PCB and sensor, including all plug connections.

Code/meaning	Possible cause	Measure
F.024 The temperature increases too quickly.	Fault in the electrical connection for the return temperature sensor	▶ Check and, if required, replace the wiring harness between the PCB and sensor, including all plug connections.
	Flow temperature sensor defective	▶ Check and, if required, replace the flow temperature sensor.
	Return temperature sensor defective	▶ Check and, if required, replace the return temperature sensor.
	Pump blocked	▶ Check that the pump is working correctly.
	Pump runs with insufficient output	▶ Check that the pump is working correctly.
	3-port diverter valve defective or blocked	▶ Check and, if required, replace the 3-port diverter valve.
	Internal expansion vessel defective	▶ Check the internal expansion vessel and replace it, if necessary.
F.025 The flue gas temperature is too high.	Wiring harness defective	▶ Check the wiring harness including all plug connections and, if required, replace it (PCB plug X20, contact 14/15).
	If present: Flue gas temperature monitor has triggered	▶ Check and, if required, replace the flue gas temperature monitor.
F.027 A flame signal has been detected while the burner is off.	Gas solenoid valve not leak-tight	▶ Check that the gas valve assembly is working correctly and, if required, replace it.
	PCB defective	▶ Replace the PCB.
F.028 The flame signal was not detected during the ignition phase.	Hard ignition takes place	1. Check the heat exchanger, siphon, siphon adapter, siphon hose (connection between the primary heat exchanger and the siphon, and siphon hose outside of the product), flue pipe adapter, unit housing, front casing and side section for possible damage. 2. If required, replace any damaged parts immediately.
	Gas isolator cock closed	▶ Open the gas isolator cock.
	Gas connection pressure too low	▶ Check the gas connection pressure.
	Air in the gas supply (e.g. during initial start-up)	▶ Reset the unit once.
	Incorrect gas type set	▶ Check the gas type and the gas type setting under D.156 and D.157 .
	Gas valve assembly offset incorrectly stored in D.052 and ggf. D.182	▶ Check the offset setting for the gas valve assembly.
	Air intake pipe blocked	▶ Check and, if required, replace the air intake pipe.
	Ignition failed	1. Check the ignition using check programme P.021 . 2. Product starts: Ignition electrode, ignition transformer, gas valve assembly and fan are working, gas is flowing and the gas volume is correct, no blockage or recirculation detected. 3. Product does not start and displays F.028 again: Carry out the next check for the cause.
	Gas flow pressure too low	▶ Check the gas flow pressure and the external gas pressure switch.
	Control electrode comes into contact with the burner	1. Check the clearance between the control electrode and the burner. 2. Check and, if required, replace the control electrode.
	Ignition electrode defective	▶ Check and, if required, replace the ignition electrode.
	Burner defective	▶ Check and, if required, replace the burner.
	Condensate pump (if fitted) defective	▶ Check and clean the condensate pump. Replace the condensate pump, if required.
	Gas valve assembly defective/incorrect spare part gas valve assembly	▶ Check and, if required, replace the gas valve assembly.
	Interruption in the wiring harness	▶ Check the wiring harness including all plug connections and, if required, replace it.
	Earthing defective	▶ Check the product's earthing.
Ionisation flow interrupted	▶ Check the control electrode, the connection cable and the plug connection.	

Code/meaning	Possible cause	Measure
F.028 The flame signal was not detected during the ignition phase.	Fault in the flue gas route caused by recirculation or flue gas blockage	► Check the entire flue gas route.
	Ignition transformer not connected	► Check the plug and the plug connection.
	Defective ignition transformer	► Check that the ignition transformer is working correctly and, if required, replace it.
	PCB defective	► Replace the PCB.
	Condensate in the combustion chamber due to a blocked condensate discharge	1. Check and, if required, clean the condensate discharge pipe including the siphon. 2. Check the combustion chamber (electrodes, insulating mats, burner). 3. If required, replace the insulating mats in the combustion chamber.
F.029 The ignition following a flame loss during operation was unsuccessful.	The gas supply is interrupted	► Check the gas supply.
	Fault in the flue gas route caused by recirculation or flue gas blockage	► Check the entire flue gas route.
	Earthing defective	► Check the product's earthing.
	Air intake pipe blocked	► Check and, if required, replace the air intake pipe.
	Ignition misfire	► Check that the ignition transformer works correctly.
	Condensate pump (if fitted) defective	► Check and clean the condensate pump. Replace the condensate pump, if required.
	Control electrode comes into contact with the burner	1. Check the clearance between the control electrode and the burner. 2. Check and, if required, replace the control electrode.
	Burner defective	► Check and, if required, replace the burner.
	Interruption in the wiring harness	► Check the wiring harness including all plug connections and, if required, replace it.
	Ignition electrode defective	► Check and, if required, replace the ignition electrode.
	Gas valve assembly defective/incorrect spare part gas valve assembly	► Check and, if required, replace the gas valve assembly.
	Condensate in the combustion chamber due to a blocked condensate discharge	1. Check and, if required, clean the condensate discharge pipe including the siphon. 2. Check the combustion chamber (electrodes, insulating mats, burner). 3. If required, replace the insulating mats in the combustion chamber.
F.032 The fan speed is outside of the tolerance.	Fault in the electrical connection for the fan	► Check the wiring harness between the PCB and fan, including all plug connections.
	Fan blocked	► Check that the fan works correctly.
	Fan defective	► Check and, if required, replace the fan.
	Fault in the flue gas route caused by recirculation or flue gas blockage	► Check the entire flue gas route.
	PCB defective	► Replace the PCB.
F.035 The air/flue pipe is blocked.	Air/flue pipe blocked during initial start-up	► Check the entire flue gas route and deactivate D.145 .
	Air intake pipe blocked	► Check and, if required, replace the air intake pipe.
	Gas flow pressure too low	► Check the gas flow pressure and the external gas pressure switch.
	Fault in the flue gas route caused by recirculation or flue gas blockage	► Check the entire flue gas route.
	Condensate in the combustion chamber due to a blocked condensate discharge	1. Check and, if required, clean the condensate discharge pipe including the siphon. 2. Check the combustion chamber (electrodes, insulating mats, burner). 3. If required, replace the insulating mats in the combustion chamber.

Code/meaning	Possible cause	Measure
F.035 The air/flue pipe is blocked.	Condensate pump (if fitted) defective	▶ Check and clean the condensate pump. Replace the condensate pump, if required.
	Insufficient combustion air supply	▶ Check the combustion air supply.
	Control electrode defective	▶ Check and, if required, replace the control electrode.
	Burner defective	▶ Check and, if required, replace the burner.
	Gas valve assembly defective/incorrect spare part gas valve assembly	▶ Check and, if required, replace the gas valve assembly.
F.040 The air ratio is too low.	Fault in the flue gas route caused by recirculation or flue gas blockage	▶ Check the entire flue gas route.
	Air intake pipe blocked	▶ Check and, if required, replace the air intake pipe.
	Condensate in the combustion chamber due to a blocked condensate discharge	1. Check and, if required, clean the condensate discharge pipe including the siphon. 2. Check the combustion chamber (electrodes, insulating mats, burner). 3. If required, replace the insulating mats in the combustion chamber.
	Condensate pump (if fitted) defective	▶ Check and clean the condensate pump. Replace the condensate pump, if required.
	Incorrect gas type set	▶ Check the gas type and the gas type setting under D.156 and D.157 .
	Gas valve assembly offset incorrectly stored in D.052 und ggf. D.182	▶ Check the offset setting for the gas valve assembly.
	Fault in the electrical connection for the gas valve assembly	▶ Check and, if required, replace the wiring harness for the gas valve assembly.
	Gas valve assembly not electrically connected/incorrectly connected	▶ Check the electrical connection to the gas valve assembly.
	Control electrode defective	▶ Check and, if required, replace the control electrode.
	Burner defective	▶ Check and, if required, replace the burner.
	PCB defective	▶ Replace the PCB.
	Fan defective	▶ Check and, if required, replace the fan.
	Air-mass flow sensor dirty or defective (only in conjunction with the conversion set comprising the air intake pipe with integrated non-return valve and air-mass flow sensor)	1. Check the air-mass flow sensor for dirt. 2. If required, replace the entire air intake pipe.
F.042 The coding resistor (in the wiring harness) or the gas group resistor (on the PCB, if available) is invalid.	▶ Check the wiring harness between the PCB and gas valve assembly, including all plug connections (especially on the PCB).	
F.044 The ionisation signal for the control electrode is too low. The drift adaptation has failed.	Fault in the flue gas route caused by recirculation or flue gas blockage	▶ Check the entire flue gas route.
	Air intake pipe blocked	▶ Check and, if required, replace the air intake pipe.
	Condensate in the combustion chamber due to a blocked condensate discharge	1. Check and, if required, clean the condensate discharge pipe including the siphon. 2. Check the combustion chamber (electrodes, insulating mats, burner). 3. If required, replace the insulating mats in the combustion chamber.
	Condensate pump (if fitted) defective	▶ Check and clean the condensate pump. Replace the condensate pump, if required.
	Gas flow pressure too low	▶ Check the gas flow pressure and the external gas pressure switch.
	Incorrect gas type set	▶ Check the gas type and the gas type setting under D.156 and D.157 .

Code/meaning	Possible cause	Measure
F.044 The ionisation signal for the control electrode is too low. The drift adaptation has failed.	Interruption in the wiring harness	▶ Check the wiring harness including all plug connections and, if required, replace it.
	Burner defective	▶ Check and, if required, replace the burner.
	Gas valve assembly defective/incorrect spare part gas valve assembly	▶ Check and, if required, replace the gas valve assembly.
	Gas valve assembly offset incorrectly stored in D.052 und ggf. D.182	▶ Check the offset setting for the gas valve assembly.
	Control electrode defective	▶ Check and, if required, replace the control electrode.
	Gas valve defective	▶ Replace the gas valve.
	PCB defective	▶ Replace the PCB.
F.047 The signal for the domestic hot water temperature sensor at the output for the internal cylinder is implausible.	Fault in the electronic connection for the cylinder outlet temperature sensor	▶ Check the wiring harness between the PCB and sensor, including all plug connections.
	Cylinder outlet temperature sensor defective	▶ Replace the cylinder outlet temperature sensor.
F.049 The eBUS has short-circuited or two active eBUS sources have inverted polarity.	Short circuit in the eBUS connection	▶ Check all eBUS connections.
	Different polarities at the eBUS connection	▶ Check the polarity (\pm) of the eBUS connections.
	PCB defective	▶ Replace the PCB.
F.057 The combustion regulation has failed and the associated limp home mode has failed.	Limp home mode failed	▶ Check the limp home mode and fault history, and carry out the required measures.
	Fault in the flue gas route caused by recirculation or flue gas blockage	▶ Check the entire flue gas route.
	Air intake pipe blocked	▶ Check and, if required, replace the air intake pipe.
	Condensate in the combustion chamber due to a blocked condensate discharge	<ol style="list-style-type: none"> 1. Check and, if required, clean the condensate discharge pipe including the siphon. 2. Check the combustion chamber (electrodes, insulating mats, burner). 3. If required, replace the insulating mats in the combustion chamber.
	Condensate pump (if fitted) defective	▶ Check and clean the condensate pump. Replace the condensate pump, if required.
	Gas flow pressure too low	▶ Check the gas flow pressure and the external gas pressure switch.
	Gas valve assembly offset incorrectly stored in D.052 und ggf. D.182	▶ Check the offset setting for the gas valve assembly.
	Interruption in the wiring harness	▶ Check the wiring harness including all plug connections and, if required, replace it.
	PCB defective	▶ Replace the PCB.
	Fan defective	▶ Use D.033 and D.034 to check whether the fan speed deviates by more than 20–30 rpm.
	Air-mass flow sensor dirty or defective (only in conjunction with the conversion set comprising the air intake pipe with integrated non-return valve and air-mass flow sensor)	<ol style="list-style-type: none"> 1. Check the air-mass flow sensor for dirt. 2. If required, replace the entire air intake pipe.
F.061 The ASIC or μ Control does not run in the defined times.	Fault in the electrical connection for the gas valve assembly	▶ Check and, if required, replace the wiring harness for the gas valve assembly.
	PCB defective	▶ Replace the PCB.
F.062 The flame switch-off was detected after a delay.	Gas valve defective	▶ Replace the gas valve.
	PCB defective	▶ Replace the PCB.
	Ignition electrode defective	▶ Check and, if required, replace the ignition electrode.
F.063 EEPROM reports faults during the read/write test.	PCB defective	▶ Replace the PCB.

Code/meaning	Possible cause	Measure
F.064 The sensor signal could not be converted correctly.	Sensor defective	▶ Check the sensor displayed under D.166 .
	PCB defective	▶ If the displayed value for D.166 is > 20 and is not listed, replace the PCB.
F.065 The permissible operating temperature range for an electronic component has been exceeded.	Electronics overheated	▶ Check the external heat effects on the electronics.
	PCB defective	▶ Replace the PCB.
F.067 The flame monitor is defective.	Implausible flame signal	▶ Check the flame signal.
	PCB defective	▶ Replace the PCB.
F.068 The flame monitor reports an unstable signal.	PCB defective	▶ Replace the PCB.
F.070 The Device Specific Number (DSN) is incorrect, missing or does not match the coding resistor.	Device Specific Number not set correctly following simultaneous replacement of the PCB and display	1. Set the correct Device Specific Number. 2. Following simultaneous replacement of the PCB and display, replace the control electrode.
	Fault in the electrical connection for the gas valve assembly	▶ Check the wiring harness between the PCB and gas valve assembly, including all plug connections.
F.071 Flow temperature sensor returns implausible values.	Flow temperature sensor in the incorrect position	▶ Check the positioning of the flow temperature sensor.
	Flow temperature sensor defective	▶ Check and, if required, replace the flow temperature sensor.
F.072 The temperature spread between the flow and return temperature sensor is invalid.	Flow temperature sensor defective	▶ Check and, if required, replace the flow temperature sensor.
	Fault in the electrical connection for the flow temperature sensor	▶ Check and, if required, replace the wiring harness between the PCB and sensor, including all plug connections.
	Return temperature sensor defective	▶ Check and, if required, replace the return temperature sensor.
	Fault in the electrical connection for the return temperature sensor	▶ Check and, if required, replace the wiring harness between the PCB and sensor, including all plug connections.
F.074 The signal for the water pressure sensor has been interrupted.	Fault in the electrical connection for the water pressure sensor	▶ Check the wiring harness including all plug connections and, if required, replace it.
	Water pressure sensor defective	▶ Check and, if required, replace the water pressure sensor.
F.075 The pressure change is too low when the heating pump is started up.	Water pressure sensor defective	▶ Check and, if required, replace the water pressure sensor.
	Internal heating pump defective	▶ Replace the internal heating pump.
	System pressure too low	▶ Check the system pressure.
	Internal expansion vessel defective	▶ Check the internal expansion vessel and replace it, if necessary.
	Insufficient/no water in the product.	1. Fill the heating installation. 2. Check the product and the system for leakages.
	Air in the product	▶ Purge the heating installation.
	Open circuit in wiring harness (LIN cable)	▶ Check the wiring harness (LIN cable).
F.076 The overheating protection for the primary heat exchanger is active.	Interruption in the wiring harness	▶ Check the wiring harness including all plug connections and, if required, replace it.
	Interruption in the wiring harness	▶ Check the wiring harness including all plug connections and, if required, replace it (PCB plug X20, contact 3/14).
F.077 A condensate pump or an external flue non-return flap is blocking the burner operation.	No feedback from the flue non-return flap or the feedback is incorrect	▶ Check that the flue non-return flap functions correctly.
	Flue non-return flap defective	▶ Replace the flue non-return flap.
	Fault in the electrical connection to the condensate pump	▶ Check the electrical connection to the condensate pump.
	Condensate pump defective	▶ Replace the condensate pump.
F.078 The control centre is not supported by the unit.	Incorrect control module connected	▶ Check whether the control module is compatible with the product.

Code/meaning	Possible cause	Measure
F.078 The control centre is not supported by the unit.	Fault in the electrical connection for the domestic hot water connection temperature sensor	<ol style="list-style-type: none"> For products without integrated domestic hot water generation: Check whether the bridge on plug X2 between contacts 2 and 5 is plugged in and is without interruption. If the bridge is working correctly, check and, if necessary, replace the wiring harness between the PCB and sensor.
F.080 The cold water inlet temperature sensor in the internal cylinder is defective.	Inlet temperature sensor defective or not connected	▶ Check and, if required, replace the NTC sensor, plug, wiring harness and the PCB.
F.081 Cylinder charging has failed.	Interruption in the wiring harness	▶ Check the wiring harness to the internal cylinder.
	Secondary heat exchanger clogged/blocked	▶ Check the secondary heat exchanger for dirt.
	Pump non-return valve blocked	▶ Check that the non-return valve for the pump in the internal cylinder is working correctly.
	Plug on domestic hot water connection temperature sensor loose/not plugged in	▶ Check the plug and the plug connection for the domestic hot water connection temperature sensor.
	Domestic hot water connection temperature sensor installed incorrectly	▶ Check whether the temperature sensor on the domestic hot water connection is correctly installed on the pipe.
	Pump blocked	▶ Check that the pump in the internal cylinder is working correctly.
	The pump is defective.	▶ Replace the pump in the internal cylinder.
	3-port diverter valve defective or blocked	▶ Check and, if required, replace the 3-port diverter valve.
	Impeller sensor in the shift-load cylinder is defective	▶ Check and, if required, replace the impeller sensor in the shift-load cylinder.
F.083 When the burner starts, no temperature increase is registered at the flow or return temperature sensor or the temperature increase here is too slow.	System pressure too low	▶ Check the system pressure.
	Flow temperature sensor: No contact	▶ Check whether the flow temperature sensor is lying against the flow pipe correctly.
	Fault in the electrical connection for the flow temperature sensor	▶ Check and, if required, replace the wiring harness between the PCB and sensor, including all plug connections.
	Return temperature sensor: No contact	▶ Check whether the return temperature sensor is lying against the return pipe correctly.
	Fault in the electrical connection for the return temperature sensor	▶ Check and, if required, replace the wiring harness between the PCB and sensor, including all plug connections.
	Insufficient/no water in the product.	<ol style="list-style-type: none"> Fill the heating installation. Check the product and the system for leakages.
F.084 The temperature difference between the flow and return temperature sensors returns implausible values.	Flow temperature sensor installed incorrectly	▶ Check whether the flow temperature sensor has been installed correctly.
	Return temperature sensor installed incorrectly	▶ Check whether the return temperature sensor has been installed correctly.
	Flow and return temperature sensors inverted	▶ Check whether the flow and return temperature sensor has been installed correctly.
F.085 The NTC sensors are installed incorrectly.	Flow/return temperature sensors have been installed on the same pipe/wrong pipe	▶ Check that the flow and return temperature sensors have been installed on the correct pipe.
F.087 The ignition transformer is not connected to the PCB.	Fault in the electrical connection for the ignition transformer	▶ Check the wiring harness between the PCB and ignition transformer, including all plug connections.
	Defective ignition transformer	▶ Check that the ignition transformer is working correctly and, if required, replace it.
F.088 The electrical connection to the gas valve has been interrupted.	Gas valve assembly not connected	▶ Check the connection to the gas valve assembly.
	Gas valve assembly connected incorrectly	▶ Check the connection to the gas valve assembly.
	Short circuit in the wiring harness	▶ Check the wiring harness and, if required, replace it.
F.089 The installed heating pump does not match the unit type.	Incorrect pump connected	▶ Check whether the pump that is connected is the one that is recommended for the product.

Code/meaning	Possible cause	Measure
F.090 Communication with the internal cylinder has been interrupted.	Interruption in the wiring harness	▶ Check the wiring harness including all plug connections and, if required, replace it.
	Plug on PCB loose/not plugged in	▶ Check the plug and the plug connection.
F.092 The gas-type conversion was not completed correctly.	Gas conversion in D.156 not completed	▶ Check the setting in D.156 .
F.095 The gas valve stepper motor has reached the minimum permissible step number.	Fault in the flue gas route caused by recirculation or flue gas blockage	▶ Check the entire flue gas route.
	Condensate in the combustion chamber due to a blocked condensate discharge	1. Check and, if required, clean the condensate discharge pipe including the siphon. 2. Check the combustion chamber (electrodes, insulating mats, burner). 3. If required, replace the insulating mats in the combustion chamber.
	Condensate pump (if fitted) defective	▶ Check and clean the condensate pump. Replace the condensate pump, if required.
	Incorrect gas type set	▶ Check the gas type and the gas type setting under D.156 and D.157 .
	Gas valve assembly offset incorrectly stored in D.052 and ggf. D.182	▶ Check the offset setting for the gas valve assembly.
	Burner defective	▶ Check and, if required, replace the burner.
	Gas valve assembly defective/incorrect spare part gas valve assembly	▶ Check and, if required, replace the gas valve assembly.
	Fault in the electrical connection for the gas valve assembly	▶ Check the wiring harness between the PCB and gas valve assembly, including all plug connections.
	Control electrode defective	▶ Check and, if required, replace the control electrode.
	PCB defective	▶ Replace the PCB.
	Air-mass flow sensor dirty or defective (only in conjunction with the conversion set comprising the air intake pipe with integrated non-return valve and air-mass flow sensor)	1. Check the air-mass flow sensor for dirt. 2. If required, replace the entire air intake pipe.
	F.096 The gas valve stepper motor has reached the maximum permissible step number.	Gas connection pressure too low
Fault in the flue gas route caused by recirculation or flue gas blockage		▶ Check the entire flue gas route.
Incorrect gas type set		▶ Check the gas type and the gas type setting under D.156 and D.157 .
Gas valve assembly offset incorrectly stored in D.052 and ggf. D.182		▶ Check the offset setting for the gas valve assembly.
Condensate in the combustion chamber due to a blocked condensate discharge		1. Check and, if required, clean the condensate discharge pipe including the siphon. 2. Check the combustion chamber (electrodes, insulating mats, burner). 3. If required, replace the insulating mats in the combustion chamber.
Condensate pump (if fitted) defective		▶ Check and clean the condensate pump. Replace the condensate pump, if required.
Fault in the electrical connection for the gas valve assembly		▶ Check the wiring harness between the PCB and gas valve assembly, including all plug connections.
Control electrode defective		▶ Check and, if required, replace the control electrode.
Burner defective		▶ Check and, if required, replace the burner.
Gas valve assembly defective/incorrect spare part gas valve assembly		▶ Check and, if required, replace the gas valve assembly.
PCB defective	▶ Replace the PCB.	

Code/meaning	Possible cause	Measure
F.096 The gas valve stepper motor has reached the maximum permissible step number.	Air-mass flow sensor dirty or defective (only in conjunction with the conversion set comprising the air intake pipe with integrated non-return valve and air-mass flow sensor)	<ol style="list-style-type: none"> 1. Check the air-mass flow sensor for dirt. 2. If required, replace the entire air intake pipe.
F.097 The self-test of the main PCB has failed.	PCB self-test failed (PCB defective)	▶ Replace the PCB.
F.105 If the gas valve or the PCB and the unit interface are replaced, the gas valve offset must be set in accordance with the current gas valve.	Gas valve assembly offset incorrectly stored in D.052 und ggf. D.182	▶ Check the offset setting for the gas valve assembly.
	Fault in the electrical connection for the gas valve assembly	▶ Check the wiring harness between the PCB and gas valve assembly, incl. all plug connections.
F.194 The power supply unit for the PCB is defective.	Power supply unit for the PCB is defective	▶ Replace the PCB.
F.195 The unit has detected significant undervoltage in the power supply.	Undervoltage in the power supply	<ul style="list-style-type: none"> ▶ Check the mains voltage. ▶ If the mains voltage is not correct, contact the energy supply company.
	Pump defective	▶ If the mains voltage is correct, replace the pump (voltage measurement via pump electronics).
	Fault in the electrical connection for the pump	▶ Check the wiring harness between the PCB and pump, including all plug connections.
F.196 The unit has detected significant overvoltage in the power supply.	Overvoltage in the power supply	▶ If the mains voltage is not correct, contact the energy supply company.
	Pump defective	▶ If the mains voltage is correct, replace the pump (voltage measurement via pump electronics).
	Fault in the electrical connection for the pump	▶ Check the wiring harness between the PCB and pump, including all plug connections.
F.317 The signal for the volume flow sensor in the domestic hot water circuit is implausible.	Fault in the electrical connection for the volume flow sensor in the domestic hot water circuit	▶ Check the wiring harness between the PCB and volume flow sensor, including all plug connections.
	Volume flow sensor in the domestic hot water circuit defective	▶ Replace the volume flow sensor in the domestic hot water circuit.
F.318 The 3-port motorised valve does not move.	Fault in the electrical connection for the 3-port diverter valve	▶ Check the wiring harness between the PCB and 3-port diverter valve, including all plug connections.
	3-port diverter valve defective or blocked	▶ Check and, if required, replace the 3-port diverter valve.
F.320 The heating pump is blocked. The unlocking function was not successful.	Dirt or foreign bodies in the pump	▶ Clean the pump and, if required, replace the pump.
F.321 The pump electronics are defective.	The pump is defective.	▶ Check and, if required, replace the pump.
F.322 The heating pump has overheated. The temperature could not be lowered by the limp home mode.	The pump temporarily reports excessive temperatures in the electronics	▶ Check the pump and, if required, replace the pump.
F.323 The heating pump is dry running.	Air in the product	▶ Purge the heating installation.
	Pump has been dry-running	▶ Replace the pump.
F.324 The electrical connection to the pump has been interrupted.	The cable to the pump is defective	▶ Check the cable for the 230 V power supply to the pump and, if required, replace the cable for the 230 V power supply.
	The pump is defective.	▶ Check and, if required, replace the pump.
F.325 The heating pump has a fault.	Pump blocked	▶ Check that the pump is working correctly.
	The pump is defective.	▶ Check and, if required, replace the pump.

Code/meaning	Possible cause	Measure
F.326 The hydraulic sensor and actuator test has detected at least two hydraulic components that are not working.	3-port diverter valve defective or blocked	▶ Check and, if required, replace the 3-port diverter valve.
	Plug on 3-port motorised valve loose/not plugged in	▶ Check the plug and the plug connection on the 3-port motorised valve.
	Interruption in the wiring harness	▶ Check the wiring harness including all plug connections and, if required, replace it.
	Domestic hot water circuit not connected	▶ Connect the domestic hot water circuit.
	External pump runs continuously	▶ Check the external pump and the system configuration.
	The pump is defective.	▶ Check and, if required, replace the pump.
F.327 The minimum heating volume flow is limited due to there being no domestic hot water circuit connected.	Cylinder bypass not connected	▶ Check the cylinder connection pipes.
	Domestic hot water circuit clogged/blocked	▶ Check the secondary heat exchanger for dirt.
F.330 The pump is not responding to commands during the hydraulic test.	Fault in the electrical connection for the pump	▶ Check the wiring harness between the PCB and pump, including all plug connections.
	The pump is defective.	▶ Check and, if required, replace the pump.
F.334 The configuration of the flue system was not completed.	Flue system configuration not completed	▶ Check the flue gas configuration and complete this.
F.336 The unit is not permitted in this configuration.	Flue system configuration set incorrectly	▶ Set the approved flue system configuration.
	Incorrect gas type set	▶ Check the gas type and the gas type setting under D.156 and D.157 .
F.337 The multiple-flue configuration conversion set is not suitable for the heat cell.	The multiple-flue configuration conversion set is not suitable for the heat cell	▶ Check and, if required, replace the conversion set comprising air intake pipe with integrated non-return valve and air-mass flow sensor.
F.338 Incorrect multiple-flue configuration setting	Multiple-flue configuration set incorrectly	▶ Set the approved flue system configuration.
F.342 The air-mass flow is not within the permitted limits.	Fan speed does not correspond to the target value	▶ Use D.033 and D.034 to check whether the fan speed deviates by more than 20–30 rpm.
	Plug on PCB loose/not plugged in	▶ Check the plug and the plug connection.
	Interruption in the wiring harness	▶ Check the wiring harness including all plug connections and, if required, replace it.
	Plug for air-mass flow sensor loose/not plugged in	▶ Check the plug and the plug connection for the air-mass flow sensor.
	You exit the measuring range permanently. Air-mass flow sensor defective	▶ Replace the entire air intake pipe.
	Flue gas pipe blocked	▶ Check the entire flue gas pipe.
F.343 The signal for the air-mass flow sensor is not plausible.	Plug for air-mass flow sensor loose/not plugged in	▶ Check the plug and the plug connection for the air-mass flow sensor.
	Plug on PCB loose/not plugged in	▶ Check the plug and the plug connection.
	Interruption in the wiring harness	▶ Check the wiring harness including all plug connections and, if required, replace it.
	Measurement discrepancy too high. Air-mass flow sensor dirty.	▶ Check the air-mass flow sensor for dirt.
	You exit the measuring range permanently. Air-mass flow sensor defective	▶ Replace the entire air intake pipe.
	PCB defective	▶ Replace the PCB.
F.344 The control electrode can no longer be used.	Transmission fault for calibration values	▶ Replace the control electrode (D.146 , D.147).



Code/meaning	Possible cause	Measure
F.347 Condensate has been detected in the combustion chamber. The burner operation is interrupted.	Condensate in the combustion chamber due to a blocked condensate discharge	<ol style="list-style-type: none"> 1. Check and, if required, clean the condensate discharge pipe including the siphon. 2. Check the combustion chamber (electrodes, insulating mats, burner). 3. If required, replace the insulating mats in the combustion chamber.
F.363 The display's EEPROM reports errors during the read/write test.	Display electronics defective	► Replace the display.
F.707 No communication is possible between the display and the PCB.	Communication between the display and the PCB is interrupted	<ol style="list-style-type: none"> 1. Check the connection between the display and the PCB. 2. If required, replace the cable between the display and the PCB. 3. If required, replace the display or the PCB.
F.905 Communication interface switched off	Overcurrent at the communication interface	<ol style="list-style-type: none"> 1. Check the connection between the PCB and the modules that are connected to the interface. 2. Check the connected modules and replace these, if required.

G Check programmes



Note

Since the code table is used for various products, some codes may not be visible for the product in question. Check programmes (**P.XXX**) can temporarily block **L.XXX** codes.

Check programme	Meaning
P.000 Purge programme	The internal pump is cyclically actuated. The heating circuit and the domestic hot water circuit are adaptively purged by automatically switching the circuits using the automatic air vent (the automatic air vent's flap must be loose). The active circuit is shown in the display. Press  once to start purging the heating circuit. Press  once to end the purge programme. The duration of the purge programme is displayed using a countdown. The programme then ends.
P.001 Adjustable load	After successful ignition, the product is operated at the set heat input (query at the start of the programme).
P.003 Maximum heat load	After successful ignition, the product is operated at the partial heat load that was set under D.000 .
P.008 Filling of product with water	The prioritising diverter valve is moved to the mid-position. The burner and pump are switched off (to fill or drain the product).
P.021 Help for ignition diagnostics	The programme is used to analyse the ignition in the event of fault message F.028 . This checks whether ignition can be successfully carried out. In this case, the flame is not monitored via the control electrode. If the ignition has been carried out successfully,  appears permanently on the display during the check programme.

H Actuator test



Note

Since the code table is used for various products, some codes may not be visible for the product in question. Actuator tests (**T.XXX**) can temporarily block **L.XXX** codes.

Code	Meaning
T.001 Internal pump	The internal pump is switched on and regulated at the selected differential pressure.
T.002 3-port valve	The prioritising diverter valve is moved to the heating or domestic hot water position.
T.003 Fan	The fan is switched on and off. The fan runs at maximum rotational speed.
T.004 Cylinder charging pump	The cylinder charging pump is switched on and off.
T.005 Circulation pump	The circulation pump is switched on and off.
T.006 External pump	The external pump is switched on and off.
T.007 Min. modulation	Product starts up and switches to minimum load. The flow temperature is shown in the display.

I Maintenance codes



Note

Since the code table is used for various products, some codes may not be visible for the product in question.

Code/meaning	Possible cause	Measure
I.003 The product's maintenance time has been reached.	Maintenance interval elapsed	1. Carry out maintenance work. 2. Reset the service interval.
I.020 The water pressure in the heating system is at the lower limit.	Filling pressure of the heating installation is low	▶ Top up the heating installation.
I.144 The electrode drift test shows progressed ageing of the control electrode.	The drift test electrode has reached the maximum permissible value	▶ Replace the control electrode and reset the drift offsets via D.146 and D.147 .

J Reversible limp home mode codes



Note

Since the code table is used for various products, some codes may not be visible for the product in question. The reversible **L.XXX** codes eliminate themselves. Check programmes (**P.XXX**) and actuator tests (**T.XXX**) can temporarily block **L.XXX** codes.

Code	Meaning
L.016	A flame loss has been detected at minimum output.
L.022	The circulation water volume in the heating circuit is too low.
L.025	The cold water inlet temperature sensor has short-circuited.
L.032	The volume flow sensor is defective or the signal is not plausible.
L.095	The gas valve stepper motor has reached the minimum permissible step number.
L.096	The gas valve stepper motor has reached the maximum permissible step number.
L.097	The air ratio is too low.
L.105	The unit is not purged correctly. The purge programme could not be completed successfully.
L.144	The ionisation signal for the control electrode is too low. The drift adaptation has failed.
L.194	The power supply unit for the PCB is faulty.
L.195	The unit has detected undervoltage in the power supply.
L.196	The unit has detected overvoltage in the power supply.
L.319	The unit's internal bypass valve is blocked.
L.320	The heating pump is blocked. The unit attempts to loosen the blockage.
L.322	The pump electronics have overheated.
L.343	The signal for the air-mass flow sensor is not plausible.

K Irreversible limp home mode codes



Note

Since the code table is used for various products, some codes may not be visible for the product in question. The irreversible **N.XXX** codes require action.

Code/meaning	Possible cause	Measure
N.013 The signal for the water pressure sensor is invalid.	Water pressure sensor defective	▶ Check and, if required, replace the water pressure sensor.
	Interruption in the wiring harness	▶ Check the wiring harness including all plug connections and, if required, replace it.
	Short circuit in the connection cable	▶ Check the connection cable and, if required, replace it.

Code/meaning	Possible cause	Measure
N.027 The signal for the temperature sensor on the domestic hot water connection is implausible.	Temperature sensor defective	► Check and, if required, replace the temperature sensor.
	Short circuit in the connection cable	<ol style="list-style-type: none"> 1. Check whether the outlet temperature displayed under D.003 is 116 °C. 2. Check the wiring harness including all plug connections and, if required, replace it.
	Interruption in the wiring harness	<ol style="list-style-type: none"> 1. Check whether the outlet temperature displayed under D.003 is -13.5 °C. 2. Check the wiring harness including all plug connections and, if required, replace it.
	Domestic hot water connection temperature sensor installed incorrectly	► Check whether the temperature sensor on the domestic hot water connection is correctly installed on the pipe.
N.032 The volume flow sensor is defective or the signal is not plausible.	Air in the system	► Purge the system.
	Volume flow sensor defective	► Check and, if required, replace the volume flow sensor.
	Bypass is blocked (only for products with a bypass)	► Remove the blockage.
	Air in the pump (only for products with a bypass)	► Purge the system.
	Pump defective (only for products with a bypass)	► Replace the pump.
N.089 The installed heating pump does not match the unit type.	Incorrect pump connected	► Check whether the pump that is connected is the one that is recommended for the product.
N.095 The gas valve stepper motor has reached the minimum permissible step number.	Fault in the flue gas route caused by recirculation or flue gas blockage	► Check the entire flue gas route.
	Condensate discharge pipe blocked	► Check the condensate discharge pipe.
	Incorrect gas type set	► Check the gas type and the gas type setting under D.156 and D.157 .
	Gas valve assembly offset incorrectly stored in D.052 und ggf. D.182	► Check the offset setting for the gas valve assembly.
	Fault in the electrical connection for the gas valve assembly	► Check and, if required, replace the wiring harness for the gas valve assembly.
	Gas valve assembly not electrically connected/incorrectly connected	► Check the electrical connection to the gas valve assembly.
	Control electrode defective	► Check and, if required, replace the control electrode.
	PCB defective	► Replace the PCB.
	Air-mass flow sensor dirty or defective (only in conjunction with the conversion set comprising the air intake pipe with integrated non-return valve and air-mass flow sensor)	<ol style="list-style-type: none"> 1. Check the air-mass flow sensor for dirt. 2. If required, replace the entire air intake pipe.
N.096 The gas valve stepper motor has reached the maximum permissible step number.	Gas connection pressure too low	► Check the gas connection pressure.
	Incorrect gas type set	► Check the gas type and the gas type setting under D.156 and D.157 .
	Gas valve assembly offset incorrectly stored in D.052 und ggf. D.182	► Check the offset setting for the gas valve assembly.
	Fault in the electrical connection for the gas valve assembly	► Check and, if required, replace the wiring harness for the gas valve assembly.
	Gas valve assembly not electrically connected/incorrectly connected	► Check the electrical connection to the gas valve assembly.
	PCB defective	► Replace the PCB.

Code/meaning	Possible cause	Measure
N.096 The gas valve stepper motor has reached the maximum permissible step number.	Air-mass flow sensor dirty or defective (only in conjunction with the conversion set comprising the air intake pipe with integrated non-return valve and air-mass flow sensor)	<ol style="list-style-type: none"> 1. Check the air-mass flow sensor for dirt. 2. If required, replace the entire air intake pipe.
N.097 The air ratio is too low.	Fault in the flue gas route caused by recirculation or flue gas blockage	▶ Check the entire flue gas route.
	Condensate discharge pipe blocked	▶ Check the condensate discharge pipe.
	Gas flow pressure too low	▶ Check the gas flow pressure and the external gas pressure switch.
	Incorrect gas type set	▶ Check the gas type and the gas type setting under D.156 and D.157 .
	Gas valve assembly offset incorrectly stored in D.052 und ggf. D.182	▶ Check the offset setting for the gas valve assembly.
	Fault in the electrical connection for the gas valve assembly	▶ Check and, if required, replace the wiring harness for the gas valve assembly.
	Gas valve assembly not electrically connected/incorrectly connected	▶ Check the electrical connection to the gas valve assembly.
	Control electrode defective	▶ Check and, if required, replace the control electrode.
	PCB defective	▶ Replace the PCB.
	Fan defective	▶ Check and, if required, replace the fan.
	Air-mass flow sensor dirty or defective (only in conjunction with the conversion set comprising the air intake pipe with integrated non-return valve and air-mass flow sensor)	<ol style="list-style-type: none"> 1. Check the air-mass flow sensor for dirt. 2. If required, replace the entire air intake pipe.
N.100 The signal for the outdoor temperature sensor has been interrupted.	Outdoor temperature sensor not connected	▶ Check the settings on the control.
	Outdoor temperature sensor defective	▶ Check the outdoor temperature sensor.
	Outdoor temperature sensor not installed	▶ Deactivate the weather-compensated control using D.162 .
N.144 The ionisation signal for the control electrode is too low. The drift adaptation has failed again.	Fault in the flue gas route caused by recirculation or flue gas blockage	▶ Check the entire flue gas route.
	Condensate discharge pipe blocked	▶ Check the condensate discharge pipe.
	Gas flow pressure too low	▶ Check the gas flow pressure and the external gas pressure switch.
	Incorrect gas type set	▶ Check the gas type and the gas type setting under D.156 and D.157 .
	Control electrode defective	▶ Check and, if required, replace the control electrode.
	Gas valve defective	▶ Replace the gas valve.
	PCB defective	▶ Replace the PCB.
N.194 The power supply unit for the PCB is defective.	Power supply unit for the PCB is defective	▶ Replace the PCB.
	Interruption in the wiring harness	▶ Check the wiring harness including all plug connections and, if required, replace it.
N.270 The temperature spread via the secondary heat exchanger (heating flow – domestic hot water connection) is too high. The unit switches from regulating to controlling until the cause has been eliminated by customer service.	Strainer at cold water inlet dirty	▶ Check the strainer at the cold water inlet for dirt, clean it and, if required, replace it.
	Cold water adjusting valve not installed (only on a product with no factory-installed flow rate limiter)	▶ Install the cold water adjusting valve.

Code/meaning	Possible cause	Measure
N.270 The temperature spread via the secondary heat exchanger (heating flow – domestic hot water connection) is too high. The unit switches from regulating to controlling until the cause has been eliminated by customer service.	Flow rate quantity set incorrectly on the cold water adjusting valve (only on a product with no factory-installed flow rate limiter)	▶ Set the flow rate quantity on the cold water adjusting valve.
	Diverter valve stepper motor is defective	▶ Check the diverter valve's stepper motor for potential mechanical or electrical damage.
	Interruption in the diverter valve's wiring harness	▶ Check whether the wiring harness to the stepper motor and to the PCB is connected correctly.
	Scale in the secondary heat exchanger.	▶ Descale or, if required, replace the affected heat exchanger.
	3-port diverter valve defective	▶ Check and, if required, replace the 3-port diverter valve.
	Flow rate limiter defective	▶ Check and, if required, replace the flow rate limiter.
N.317 The signal for the volume flow sensor in the domestic hot water circuit is implausible.	Interruption in the wiring harness	▶ Check the wiring harness including all plug connections and, if required, replace it.
	Volume flow sensor in the domestic hot water circuit defective	▶ Replace the volume flow sensor in the domestic hot water circuit.
N.319 The unit's internal bypass valve is blocked.	Bypass valve dirty	▶ Clean the bypass valve.
	Bypass valve defective	▶ Replace the bypass valve.
N.324 The electrical connection to the pump has been interrupted.	Open circuit in wiring harness (LIN cable)	▶ Check the wiring harness (LIN cable).
N.343 The signal for the air-mass flow sensor is not plausible. If the sensor set for the air-mass flow is connected and there is feedback, but the values are implausible, the unit works in limp home mode.	Plug for air-mass flow sensor loose/not plugged in	▶ Check the plug and the plug connection for the air-mass flow sensor.
	Plug on PCB loose/not plugged in	▶ Check the plug and the plug connection.
	Interruption in the wiring harness	▶ Check the wiring harness including all plug connections and, if required, replace it.
	Measurement discrepancy too high. Air-mass flow sensor dirty.	▶ Check the air-mass flow sensor for dirt.
	You exit the measuring range permanently. Air-mass flow sensor defective	▶ Replace the entire air intake pipe.
	PCB defective	▶ Replace the PCB.

L Wiring diagram



Note

The slot for the X13 connection is product-dependent and may not be present.

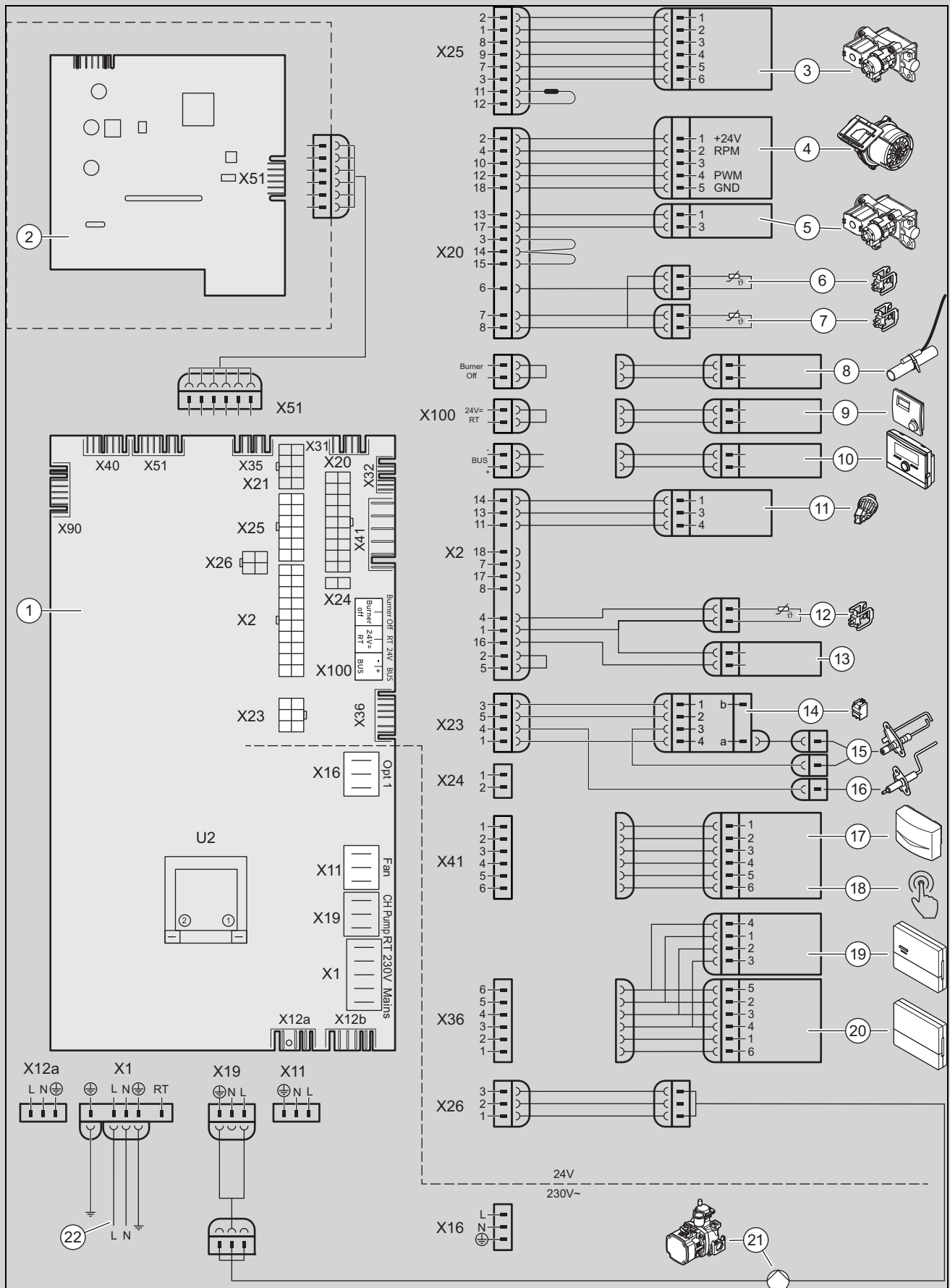

- 1 Printed circuit board
- 2 Control panel PCB
- 3 Gas valve assembly

- 4 Fan
- 5 Gas valve assembly for main gas valve
- 6 Return temperature sensor

7	Flow temperature sensor	15	Ignition electrode
8	Surface-mounted thermostat/ <i>Burner off</i>	16	Control electrode
9	24 V DC room thermostat	17	Outdoor temperature sensor, flow temperature sensor (optional, external), DCF receiver
10	Bus connection (system control/digital room thermostat)	18	Circulation pump remote control
11	Water pressure sensor	19	Control module
12	Cylinder temperature sensor (optional)	20	Communication unit
13	C1/C2 cylinder contact (optional)	21	Internal pump
14	Ignition transformer	22	Main power supply

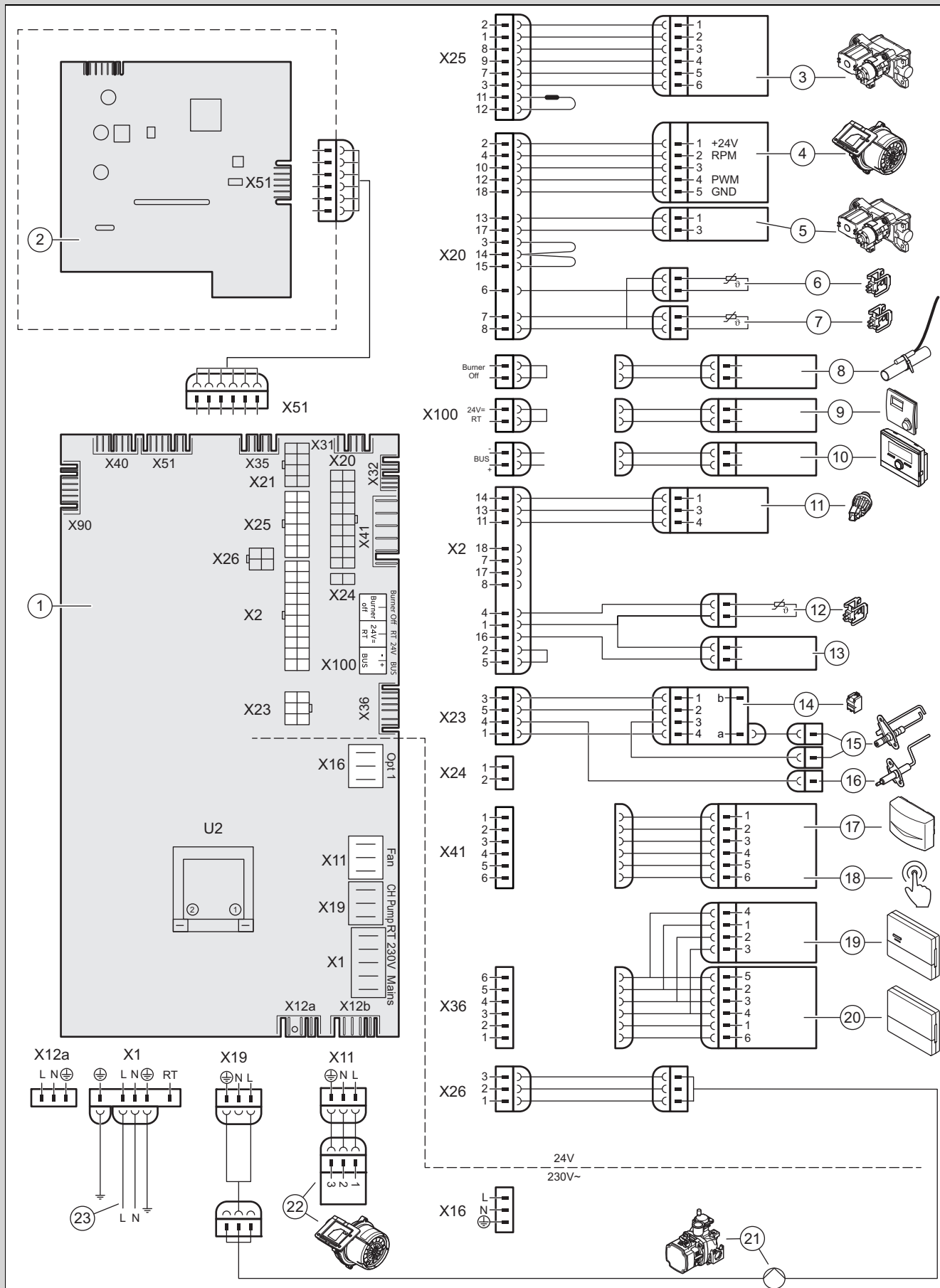

- | | | | |
|---|-----------------------|---|---------------------------------------|
| 1 | Printed circuit board | 4 | Fan |
| 2 | Control panel PCB | 5 | Gas valve assembly for main gas valve |
| 3 | Gas valve assembly | 6 | Return temperature sensor |

7	Flow temperature sensor	16	Control electrode
8	Surface-mounted thermostat/ <i>Burner off</i>	17	Outdoor temperature sensor, flow temperature sensor (optional, external), DCF receiver
9	24 V DC room thermostat	18	Circulation pump remote control
10	Bus connection (system control/digital room thermostat)	19	Control module
11	Water pressure sensor	20	Communication unit
12	Cylinder temperature sensor (optional)	21	Internal pump
13	C1/C2 cylinder contact (optional)	22	230 V fan
14	Ignition transformer	23	Main power supply
15	Ignition electrode		

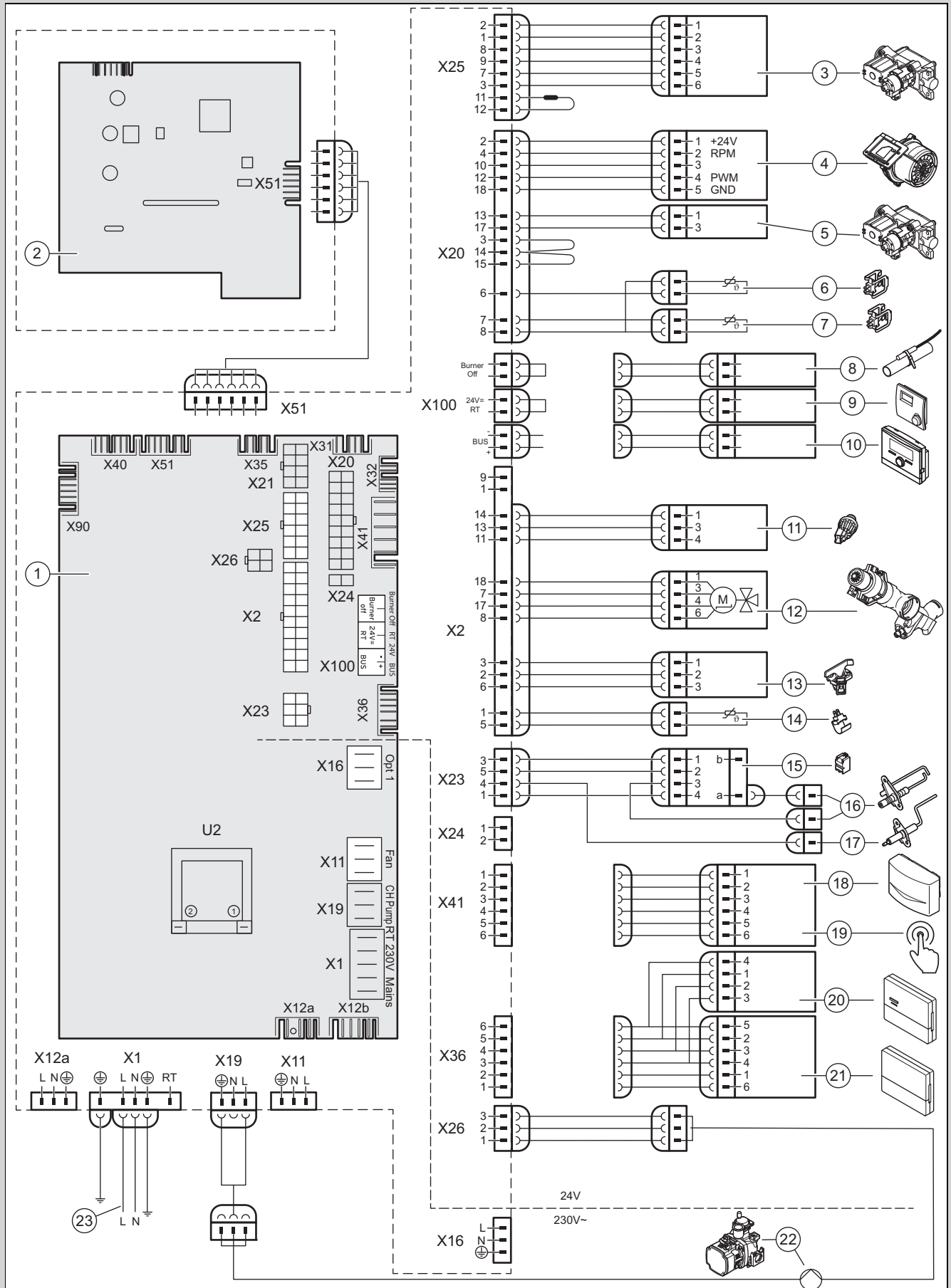

- 1 Printed circuit board
- 2 Control panel PCB
- 3 Gas valve assembly

- 4 Fan
- 5 Gas valve assembly for main gas valve
- 6 Return temperature sensor

7	Flow temperature sensor	15	Ignition transformer
8	Surface-mounted thermostat/ <i>Burner off</i>	16	Ignition electrode
9	24 V DC room thermostat	17	Control electrode
10	Bus connection (system control/digital room thermostat)	18	Outdoor temperature sensor, flow temperature sensor (optional, external), DCF receiver
11	Water pressure sensor	19	Circulation pump remote control
12	Prioritising diverter valve	20	Control module
13	Impeller water flow sensor	21	Communication unit
14	Connection temperature sensor for the domestic hot water	22	Internal pump
		23	Main power supply

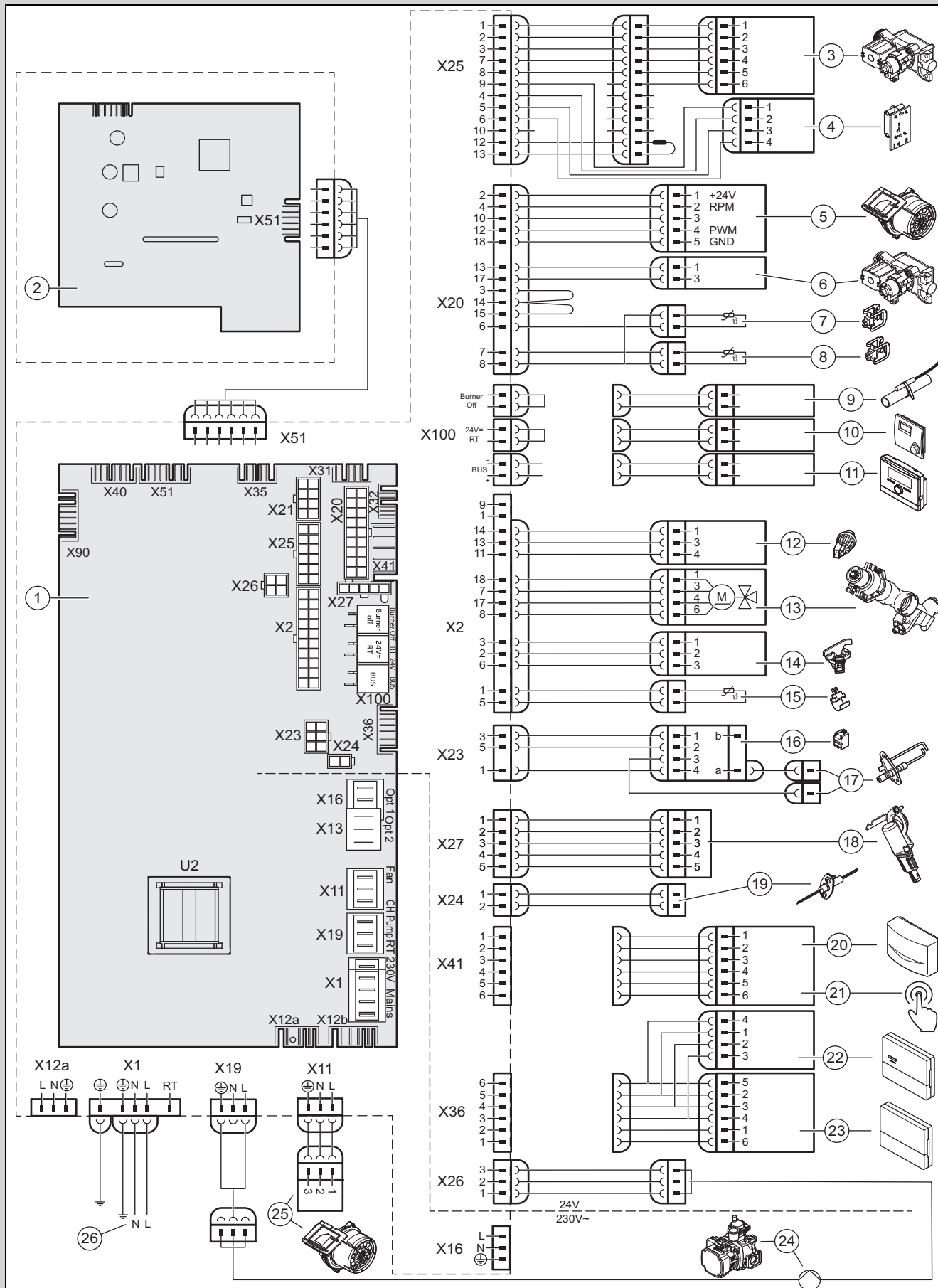

- | | | | |
|---|-----------------------|---|---------------------------------------|
| 1 | Printed circuit board | 4 | Fan |
| 2 | Control panel PCB | 5 | Gas valve assembly for main gas valve |
| 3 | Gas valve assembly | 6 | Return temperature sensor |

7	Flow temperature sensor	16	Ignition electrode
8	Surface-mounted thermostat/ <i>Burner off</i>	17	Control electrode
9	24 V DC room thermostat	18	Outdoor temperature sensor, flow temperature sensor (optional, external), DCF receiver
10	Bus connection (system control/digital room thermostat)	19	Circulation pump remote control
11	Water pressure sensor	20	Control module
12	Prioritising diverter valve	21	Communication unit
13	Impeller water flow sensor	22	Internal pump
14	Connection temperature sensor for the domestic hot water	23	230 V power supply, fan
15	Ignition transformer	24	Main power supply

Benchmark Commissioning & Warranty Validation Service Record

It is a requirement that the boiler is installed and commissioned to the manufacturers' instructions and the data fields on the commissioning checklist completed in full.

To instigate the boiler warranty the boiler needs to be registered with the manufacturer within one month of the installation. The warranty rests with the end-user (consumer), and they should be made aware it is ultimately their responsibility to register with the manufacturer, within the allotted time period.

It is essential that the boiler is serviced in line with the manufacturers' recommendations, at least annually. This must be carried out by a competent Gas Safe registered engineer. The service details should be recorded on the Benchmark Service and Interim Boiler Work Record and left with the householder. Failure to comply with the manufacturers' servicing instructions and requirements will invalidate the warranty.



www.hhic.co.uk

This Commissioning Checklist is to be completed in full by the competent person who commissioned the boiler as a means of demonstrating compliance with the appropriate Building Regulations and then handed to the customer to keep for future reference.

Failure to install and commission according to the manufacturers' instructions and complete this Benchmark Commissioning Checklist will invalidate the warranty. This does not affect the customer's statutory rights.

* All installations in England and Wales must be notified to Local Authority Building Control (LABC) either directly or through a Competent Persons Scheme. A Building Regulations Compliance Certificate will then be issued to the customer.

© Heating and Hotwater Industry Council (HHIC)



www.centralheating.co.uk

GAS BOILER SYSTEM COMMISSIONING CHECKLIST & WARRANTY VALIDATION RECORD

Address:															
Boiler make and model:															
Boiler serial number:															
Commissioned by (PRINT NAME):						Gas Safe registration number:									
Company name:						Telephone number:									
Company email:						Company address:									
										Commissioning date:					
Heating and hot water system complies with the appropriate Building Regulations?											Yes				
Optional: Building Regulations Notification Number (if applicable):															
Time, temperature control and boiler interlock provided for central heating and hot water											Yes				
Boiler Plus requirements (tick the appropriate box(s))															
Boiler Plus option chosen for combination boiler in ENGLAND						Weather compensation			Smart thermostat with automisation and optimisation						
						Load compensation			Flue Gas Heat Recovery						
Time and temperature control to hot water			Cylinder thermostat and programmer/timer						Combination boiler						
Zone valves			pre-existing			Fitted			Not required						
Thermostatic radiator valves			pre-existing			Fitted			Not required						
Automatic bypass to system			pre-existing			Fitted			Not required						
Underfloor heating			pre-existing			Fitted			Not required						
Water quality															
The system has been flushed, cleaned and a suitable inhibitor applied upon final fill, in accordance with BS7593 and boiler manufacturers' instructions											Yes				
What system cleaner was used?						Brand:			Product:						
What inhibitor was used?						Brand:			Product:						
Primary water system filter			pre-existing			Fitted			Not required						
CENTRAL HEATING MODE measure and record (as appropriate)															
Gas rate (for combination boilers complete DHW mode gas rate)						m ³ /hr			or			ft ³ /hr			
Central heating output left at factory settings?											Yes	No			
If no, what is the maximum central heating output selected?															
Dynamic gas inlet pressure											mbar				
Central heating flow temperature											°C				
Central heating return temperature											°C				
System correctly balanced/rebalanced?											Yes				
COMBINATION BOILERS ONLY															
Is the installation in a hard water area (above 200ppm)?											Yes	No			
Water scale reducer/softener			pre-existing			Fitted			Not required						
What type of scale reducer/softener has been fitted?						Brand:			Product:						
Water meter fitted?											Yes	No			
If yes- DHW expansion vessel			pre-existing			Fitted			Not required						
Pressure reducing valve			pre-existing			Fitted			Not required						
DOMESTIC HOT WATER MODE Measure and record															
Gas rate						m ³ /hr			or			ft ³ /hr			
Dynamic gas inlet pressure at maximum rate											mbar				
Cold water inlet temperature											°C				
Hot water has been checked at all outlets											Yes	Temperature	°C		
CONDENSATE DISPOSAL															
The condensate drain has been installed in accordance with the manufacturers' instructions and/or BS5546/BS6798											Yes				
Point of termination						Internal			External (only where internal termination impractical)						
Method of disposal						Gravity			Pumped						
ALL INSTALLATIONS															
Record the following		At max rate:		CO		ppm		CO ₂		%		CO/CO ₂		Ratio	
		At min rate (where possible)		CO		ppm		CO ₂		%		CO/CO ₂		Ratio	
Where possible, has a flue integrity check been undertaken in accordance with manufacturers' instructions, and readings are correct?											Yes				
The operation of the boiler and system controls have been demonstrated to and understood by the customer											Yes				
The manufacturers' literature, including Benchmark Checklist and Service Record, has been explained and left with the customer											Yes				
Commissioning Engineer's signature															
Customer's signature (To confirm satisfactory demonstration and receipt of manufacturers' literature)															

* All installations in England and Wales must be notified to Local Authority Building Control (LABC) either directly or through a Competent Persons Scheme. A Building Regulations Compliance Certificate will then be issued to the customer.

© Heating and Hotwater Industry Council (HHIC)



www.centralheating.co.uk

SERVICE & INTERIM BOILER WORK RECORD

It is recommended that your boiler and heating system are regularly serviced and maintained, in line with manufacturers' instructions, and that the appropriate service / interim work record is completed.

Service provider

When completing a service record (as below), please ensure you have carried out the service as described in the manufacturers' instructions. Always use the manufacturers' specified spare parts.

SERVICE/INTERIM WORK ON BOILER <small>delete as appropriate</small>					Date:
Engineer name:		Company name:			
Telephone N°:		Gas Safe registration N°:			
Max rate	CO	ppm	CO ₂	%	CO/CO ₂
Min rate	CO	ppm	CO ₂	%	CO/CO ₂
Where possible, has a flue integrity check been undertaken in accordance with manufacturers' instructions, and readings are correct?*					yes
Gas rate:	m ³ /h	OR	ft ³ /h		
Were parts fitted? <small>delete as appropriate</small>		Yes	No		
Parts fitted:					
System inhibitor concentration has been checked and appropriate action taken, in accordance with BS 7593 and boiler manufacturers' instructions. *					yes n/a
Comments:					
Signature:					

*A System inhibitor efficacy test is required on every annual service in accordance with the manufacturers' instructions and BS 7593. It is only acceptable to not have undertaken this if the service engineers attendance visit was in between annual services to attend a non-water facing component.

SERVICE/INTERIM WORK ON BOILER <small>delete as appropriate</small>					Date:
Engineer name:		Company name:			
Telephone N°:		Gas Safe registration N°:			
Max rate	CO	ppm	CO ₂	%	CO/CO ₂
Min rate	CO	ppm	CO ₂	%	CO/CO ₂
Where possible, has a flue integrity check been undertaken in accordance with manufacturers' instructions, and readings are correct?*					yes
Gas rate:	m ³ /h	OR	ft ³ /h		
Were parts fitted? <small>delete as appropriate</small>		Yes	No		
Parts fitted:					
System inhibitor concentration has been checked and appropriate action taken, in accordance with BS 7593 and boiler manufacturers' instructions. *					yes n/a
Comments:					
Signature:					

*A System inhibitor efficacy test is required on every annual service in accordance with the manufacturers' instructions and BS 7593. It is only acceptable to not have undertaken this if the service engineers attendance visit was in between annual services to attend a non-water facing component.

SERVICE/INTERIM WORK ON BOILER <small>delete as appropriate</small>					Date:
Engineer name:		Company name:			
Telephone N°:		Gas Safe registration N°:			
Max rate	CO	ppm	CO ₂	%	CO/CO ₂
Min rate	CO	ppm	CO ₂	%	CO/CO ₂
Where possible, has a flue integrity check been undertaken in accordance with manufacturers' instructions, and readings are correct?*					yes
Gas rate:	m ³ /h	OR	ft ³ /h		
Were parts fitted? <small>delete as appropriate</small>		Yes	No		
Parts fitted:					
System inhibitor concentration has been checked and appropriate action taken, in accordance with BS 7593 and boiler manufacturers' instructions. *					yes n/a
Comments:					
Signature:					

*A System inhibitor efficacy test is required on every annual service in accordance with the manufacturers' instructions and BS 7593. It is only acceptable to not have undertaken this if the service engineers attendance visit was in between annual services to attend a non-water facing component.

SERVICE/INTERIM WORK ON BOILER <small>delete as appropriate</small>					Date:
Engineer name:		Company name:			
Telephone N°:		Gas Safe registration N°:			
Max rate	CO	ppm	CO ₂	%	CO/CO ₂
Min rate	CO	ppm	CO ₂	%	CO/CO ₂
Where possible, has a flue integrity check been undertaken in accordance with manufacturers' instructions, and readings are correct?*					yes
Gas rate:	m ³ /h	OR	ft ³ /h		
Were parts fitted? <small>delete as appropriate</small>		Yes	No		
Parts fitted:					
System inhibitor concentration has been checked and appropriate action taken, in accordance with BS 7593 and boiler manufacturers' instructions. *					yes n/a
Comments:					
Signature:					

*A System inhibitor efficacy test is required on every annual service in accordance with the manufacturers' instructions and BS 7593. It is only acceptable to not have undertaken this if the service engineers attendance visit was in between annual services to attend a non-water facing component.

SERVICE/INTERIM WORK ON BOILER <small>delete as appropriate</small>					Date:
Engineer name:		Company name:			
Telephone N°:		Gas Safe registration N°:			
Max rate	CO	ppm	CO ₂	%	CO/CO ₂
Min rate	CO	ppm	CO ₂	%	CO/CO ₂
Where possible, has a flue integrity check been undertaken in accordance with manufacturers' instructions, and readings are correct?*					yes
Gas rate:	m ³ /h	OR	ft ³ /h		
Were parts fitted? <small>delete as appropriate</small>		Yes	No		
Parts fitted:					
System inhibitor concentration has been checked and appropriate action taken, in accordance with BS 7593 and boiler manufacturers' instructions. *					yes n/a
Comments:					
Signature:					

*A System inhibitor efficacy test is required on every annual service in accordance with the manufacturers' instructions and BS 7593. It is only acceptable to not have undertaken this if the service engineers attendance visit was in between annual services to attend a non-water facing component.

SERVICE/INTERIM WORK ON BOILER <small>delete as appropriate</small>					Date:
Engineer name:		Company name:			
Telephone N°:		Gas Safe registration N°:			
Max rate	CO	ppm	CO ₂	%	CO/CO ₂
Min rate	CO	ppm	CO ₂	%	CO/CO ₂
Where possible, has a flue integrity check been undertaken in accordance with manufacturers' instructions, and readings are correct?*					yes
Gas rate:	m ³ /h	OR	ft ³ /h		
Were parts fitted? <small>delete as appropriate</small>		Yes	No		
Parts fitted:					
System inhibitor concentration has been checked and appropriate action taken, in accordance with BS 7593 and boiler manufacturers' instructions. *					yes n/a
Comments:					
Signature:					

*A System inhibitor efficacy test is required on every annual service in accordance with the manufacturers' instructions and BS 7593. It is only acceptable to not have undertaken this if the service engineers attendance visit was in between annual services to attend a non-water facing component.

* All installations in England and Wales must be notified to Local Authority Building Control (LABC) either directly or through a Competent Persons Scheme. A Building Regulations Compliance Certificate will then be issued to the customer.

© Heating and Hotwater Industry Council (HHIC)



www.centralheating.co.uk

SERVICE & INTERIM BOILER WORK RECORD

It is recommended that your boiler and heating system are regularly serviced and maintained, in line with manufacturers' instructions, and that the appropriate service / interim work record is completed.

Service provider

When completing a service record (as below), please ensure you have carried out the service as described in the manufacturers' instructions. Always use the manufacturers' specified spare parts.

SERVICE/INTERIM WORK ON BOILER <small>delete as appropriate</small>					Date:	
Engineer name:		Company name:				
Telephone N°:		Gas Safe registration N°:				
Max rate	CO	ppm	CO ₂	%	CO/CO ₂	
Min rate	CO	ppm	CO ₂	%	CO/CO ₂	
Where possible, has a flue integrity check been undertaken in accordance with manufacturers' instructions, and readings are correct?"					yes	
Gas rate:	m ³ /h	OR	ft ³ /h			
Were parts fitted? <small>delete as appropriate</small>		Yes	No			
Parts fitted:						
System inhibitor concentration has been checked and appropriate action taken, in accordance with BS 7593 and boiler manufacturers' instructions. *					yes	n/a
Comments:						
Signature:						

*A System inhibitor efficacy test is required on every annual service in accordance with the manufacturers' instructions and BS 7593. It is only acceptable to not have undertaken this if the service engineers attendance visit was in between annual services to attend a non-water facing component.

SERVICE/INTERIM WORK ON BOILER <small>delete as appropriate</small>					Date:	
Engineer name:		Company name:				
Telephone N°:		Gas Safe registration N°:				
Max rate	CO	ppm	CO ₂	%	CO/CO ₂	
Min rate	CO	ppm	CO ₂	%	CO/CO ₂	
Where possible, has a flue integrity check been undertaken in accordance with manufacturers' instructions, and readings are correct?"					yes	
Gas rate:	m ³ /h	OR	ft ³ /h			
Were parts fitted? <small>delete as appropriate</small>		Yes	No			
Parts fitted:						
System inhibitor concentration has been checked and appropriate action taken, in accordance with BS 7593 and boiler manufacturers' instructions. *					yes	n/a
Comments:						
Signature:						

*A System inhibitor efficacy test is required on every annual service in accordance with the manufacturers' instructions and BS 7593. It is only acceptable to not have undertaken this if the service engineers attendance visit was in between annual services to attend a non-water facing component.

SERVICE/INTERIM WORK ON BOILER <small>delete as appropriate</small>					Date:	
Engineer name:		Company name:				
Telephone N°:		Gas Safe registration N°:				
Max rate	CO	ppm	CO ₂	%	CO/CO ₂	
Min rate	CO	ppm	CO ₂	%	CO/CO ₂	
Where possible, has a flue integrity check been undertaken in accordance with manufacturers' instructions, and readings are correct?"					yes	
Gas rate:	m ³ /h	OR	ft ³ /h			
Were parts fitted? <small>delete as appropriate</small>		Yes	No			
Parts fitted:						
System inhibitor concentration has been checked and appropriate action taken, in accordance with BS 7593 and boiler manufacturers' instructions. *					yes	n/a
Comments:						
Signature:						

*A System inhibitor efficacy test is required on every annual service in accordance with the manufacturers' instructions and BS 7593. It is only acceptable to not have undertaken this if the service engineers attendance visit was in between annual services to attend a non-water facing component.

SERVICE/INTERIM WORK ON BOILER <small>delete as appropriate</small>					Date:	
Engineer name:		Company name:				
Telephone N°:		Gas Safe registration N°:				
Max rate	CO	ppm	CO ₂	%	CO/CO ₂	
Min rate	CO	ppm	CO ₂	%	CO/CO ₂	
Where possible, has a flue integrity check been undertaken in accordance with manufacturers' instructions, and readings are correct?"					yes	
Gas rate:	m ³ /h	OR	ft ³ /h			
Were parts fitted? <small>delete as appropriate</small>		Yes	No			
Parts fitted:						
System inhibitor concentration has been checked and appropriate action taken, in accordance with BS 7593 and boiler manufacturers' instructions. *					yes	n/a
Comments:						
Signature:						

*A System inhibitor efficacy test is required on every annual service in accordance with the manufacturers' instructions and BS 7593. It is only acceptable to not have undertaken this if the service engineers attendance visit was in between annual services to attend a non-water facing component.

SERVICE/INTERIM WORK ON BOILER <small>delete as appropriate</small>					Date:	
Engineer name:		Company name:				
Telephone N°:		Gas Safe registration N°:				
Max rate	CO	ppm	CO ₂	%	CO/CO ₂	
Min rate	CO	ppm	CO ₂	%	CO/CO ₂	
Where possible, has a flue integrity check been undertaken in accordance with manufacturers' instructions, and readings are correct?"					yes	
Gas rate:	m ³ /h	OR	ft ³ /h			
Were parts fitted? <small>delete as appropriate</small>		Yes	No			
Parts fitted:						
System inhibitor concentration has been checked and appropriate action taken, in accordance with BS 7593 and boiler manufacturers' instructions. *					yes	n/a
Comments:						
Signature:						

*A System inhibitor efficacy test is required on every annual service in accordance with the manufacturers' instructions and BS 7593. It is only acceptable to not have undertaken this if the service engineers attendance visit was in between annual services to attend a non-water facing component.

SERVICE/INTERIM WORK ON BOILER <small>delete as appropriate</small>					Date:	
Engineer name:		Company name:				
Telephone N°:		Gas Safe registration N°:				
Max rate	CO	ppm	CO ₂	%	CO/CO ₂	
Min rate	CO	ppm	CO ₂	%	CO/CO ₂	
Where possible, has a flue integrity check been undertaken in accordance with manufacturers' instructions, and readings are correct?"					yes	
Gas rate:	m ³ /h	OR	ft ³ /h			
Were parts fitted? <small>delete as appropriate</small>		Yes	No			
Parts fitted:						
System inhibitor concentration has been checked and appropriate action taken, in accordance with BS 7593 and boiler manufacturers' instructions. *					yes	n/a
Comments:						
Signature:						

*A System inhibitor efficacy test is required on every annual service in accordance with the manufacturers' instructions and BS 7593. It is only acceptable to not have undertaken this if the service engineers attendance visit was in between annual services to attend a non-water facing component.

* All installations in England and Wales must be notified to Local Authority Building Control (LABC) either directly or through a Competent Persons Scheme. A Building Regulations Compliance Certificate will then be issued to the customer.

© Heating and Hotwater Industry Council (HHIC)



www.centralheating.co.uk

N Commissioning Flow Chart

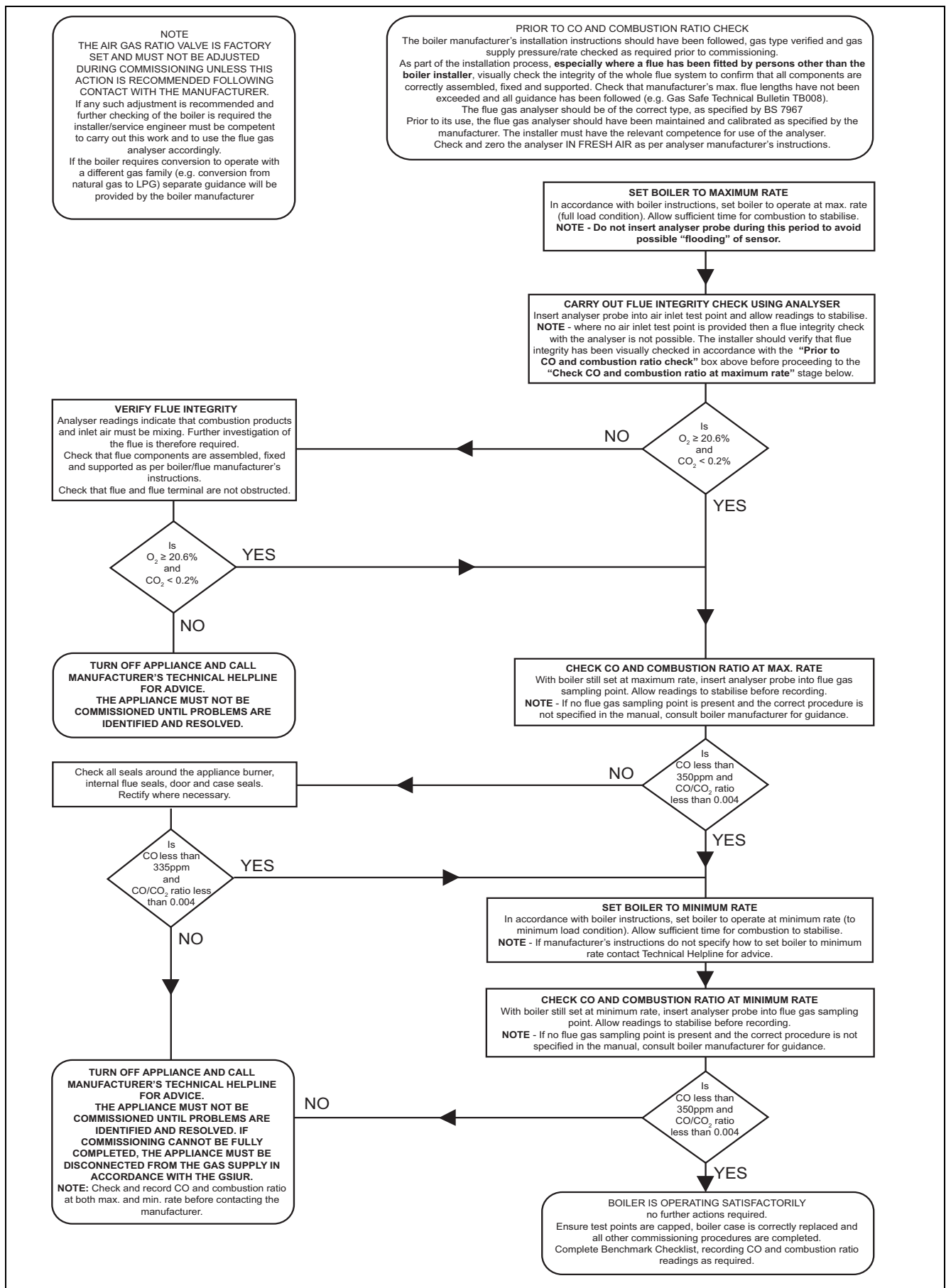

Index

A	
Actuator test	42, 54, 91
Calling up	39
Exiting	39
Advanced Key Lock	39
Air/flue pipe	26–27
Setting the type	42
Air/flue pipe, horizontal wall duct	26
Air/flue pipe, type C13	26
Air/flue pipe, type C33	26
Air/flue pipe, vertical roof duct	26
Article number	17
Automatic air vent	43
B	
Burner anti-cycling time	49
Burner flange, checking	57
Burner, checking	57
Burner, replacing	61
Button lock	39
C	
CE marking	16
Chamber aeration	21
Check programme	
Exiting	38
Check programmes	38, 42, 91
Checking the gas connection pressure	45
Checking the gas flow pressure	45
Checking the gas setting	44
Checking the heat exchanger insulating mat	55
Checking, pre-charge pressure for the internal expansion vessel	57
Chimney sweep mode	39
Cleaning the float	57
Cleaning work	56, 58
Cold water connection	28
Cold water inlet strainer, cleaning	58
Combustion analysis	39
Combustion area	55, 57
Common drain pipework, expansion relief valve and condensate discharge	31
Compact thermal module	55
Component test	54
Components	
Checking	56
Cleaning	56
Replacing	60
Condensate discharge hose	28
Condensate discharge pipe	28
Condensate siphon	57
Condensate siphon, filling	44
Condensate trap	57
Contact details	42
D	
Data overview	59
Calling up	39
Data plate	17
Date	41
Decommissioning	
Permanently	68
Temporarily	68
Desired temperature, setting	49
Diagnostics codes	38, 72
Disposal, packaging	68
Disposing of the packaging	68
Documents	16
Drain pipe, expansion relief valve	31
E	
Electronics box	33
Exiting the menu level	39
F	
Fault codes	59, 80
Fault history	59
Fault messages	59
Filling	43
Filling mode	41
Filling, condensate siphon	44
Flow temperature, setting	49
Front casing	
Installing	38
Removing	32
Frost protection	19
Frost protection active	68
Frost protection deactivated	68
G	
Gas family	22
Gas flow rate	47
Gas group	22
Gas supply	21
Gas type	22
Gas valve assembly	63
Gas valve assembly, replacing	63
Guarantee and Customer Service	8
H	
Handing over to the end user	53
Heat exchanger, cleaning	57
Heat exchanger, replacing	63
Heat input	49
Heating flow	28
Heating pump operating mode, setting	49
Heating return	28
Hot water connection	28
Hydraulic operating mode	41, 50
I	
Inspection work	56, 58
Inspection work, carrying out	54
Inspection work, completing	59
Installer level	38, 71
Installing the compact thermal module	56
Insulating mat	55, 57
Insulating mat, checking	57
Intended use	4
L	
Language	41
Leak-tightness	48
Limp home mode history	59
Limp home mode messages	59
Lines, minimum cross-section	33
Liquefied petroleum gas	21
M	
Maintenance interval	54
Maintenance work, carrying out	54
Maintenance work, completing	59
Min. heat input	49
Minimum clearance	21
O	
O ₂ content, checking	46

Operating concept.....	38
Overheating protection.....	19
Overrun time, setting.....	49
P	
Post-heating.....	53
Pre-charge pressure for the internal expansion vessel, checking.....	57
Preparing, maintenance work.....	54
Pressure level.....	51
Product	
Draining.....	58
Switching off.....	68
Product dimensions.....	20
Pump head.....	61
Purging.....	43
R	
Regulations.....	7
Repair	
Completing.....	67
Preparing.....	60
Repair work, preparing.....	54
Replacing the display.....	64
Replacing the fan.....	62
Replacing the internal expansion vessel.....	64
Replacing the PCB.....	64
Reset button.....	59
S	
Safety devices.....	19
Scale.....	23
Scale deposition.....	23
Serial number.....	17
Service messages.....	59
Setting parameters.....	48
Setting the domestic hot water temperature.....	53
Setting the heat curve.....	52
Setting the maintenance interval.....	54
Setting the max. heat input.....	49
Sitherm Pro™ technology.....	17
Spare parts.....	60
Standby.....	68
Standby mode	
Deactivate.....	41
Starting the installation assistant.....	42
Status codes.....	79
Calling up.....	39
Exiting.....	39
Switching off.....	68
T	
Technical data.....	9
Telephone number, competent person.....	42
Time.....	41
Treating the heating water.....	40
U	
UKCA mark.....	16
Unit connection piece.....	27
W	
Weight.....	21

Supplier

Vaillant Ltd.

Nottingham Road ■ Belper ■ Derbyshire ■ DE56 1JT

Telephone 0330 100 3143

info@vaillant.co.uk ■ www.vaillant.co.uk

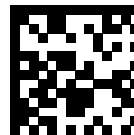

0020308118_05

Publisher/manufacture

Vaillant GmbH

Berghauser Str. 40 ■ D-42859 Remscheid

Tel. +49 2191 18 0 ■ Fax +49 2191 18 2810

info@vaillant.de ■ www.vaillant.de

© These instructions, or parts thereof, are protected by copyright and may be reproduced or distributed only with the manufacturer's written consent.

Subject to technical modifications.