

For the installer

Instructions for installation and servicing ecoTEC



Wall hung room sealed fan assisted condensing boiler

ecoTEC plus 612
ecoTEC plus 615
ecoTEC plus 618
ecoTEC plus 624
ecoTEC plus 630
ecoTEC plus 637

ecoTEC plus 824
ecoTEC plus 831
ecoTEC plus 837

ecoTEC pro 28
ecoTEC pro 24

Contents

1	Introduction	4	4.7	Removing the front case	21
1.1	Notes on the documentation.....	4	4.8	General instructions for heating system.....	21
1.1.1	Applicable documents.....	4	4.9	Gas connection.....	21
1.1.2	Retention of documents.....	4	4.10	Cold water mains inlet and hot water outlet (ecoTEC combination boilers only).....	22
1.1.3	Safety instructions and symbols.....	4	4.11	Condensate drain pipe	23
1.2	Validity of the manual.....	4	4.12	Heating connection	24
1.3	Introduction	4	4.12.1	Heating flow and return connection	24
1.4	General Notes.....	5	4.12.2	Pressure Relief Valve	25
1.5	Intended use.....	5	4.13	Connecting the flue system to the boiler	25
1.6	CE marking	5	4.14	Electrical connection.....	25
1.7	Gas council numbers.....	5	4.14.1	General requirements.....	25
2	Boiler specifications	6	4.14.2	Connection to the main supply.....	26
2.1	Technical data	6	4.14.3	Electric board layout.....	27
2.2	Dimensions	8	4.15	Controls.....	30
2.3	Installation.....	9	4.15.1	Vaillant controls and accessories.....	30
2.4	Type plate	9	4.15.2	External electrical controls	30
3	General requirements	10	4.15.3	Connection details for external time switches and boiler terminal strip	30
3.1	Preliminary remarks for room sealed appliances	10	4.15.4	Vaillant optional plug in timer accessories... ..	30
3.2	Related documents	10	4.15.5	Connection details using the VR 65 Control Center	30
3.3	Contents included with delivery	10	4.16	Thermostatic radiator valves	31
3.4	Installation site.....	12	4.17	Frost protection.....	31
3.5	Gas supply	12	4.18	Circulating pump	31
3.6	Flue pipe	13	4.19	Anticycling 'economiser' control	31
3.6.1	Standard 100 mm flue system.....	13	4.20	Automatic pump spin control (APS).....	31
3.6.2	Optional 125 mm flue system.....	13	5	Commissioning Part I	32
3.7	Flue termination.....	13	5.1	Preliminary electrical checks.....	32
3.8	Air supply	14	5.2	Gas supply.....	32
3.9	Electrical supply.....	14	5.3	Cold water supply (ecoTEC combination boilers only)	32
3.10	Guide to system requirements	15	5.4	Filling and bleeding the heating system	32
3.10.1	Water circulation system.....	15	5.4.1	Checking the filling pressure of the heating system	32
3.10.2	Filling and preparing heating system.....	15	5.4.2	ecoTEC plus combination boiler filling loop ...	32
3.10.3	Pressure relief valve	16	5.4.3	Filling the heating system in ecoTEC pro combination boilers and ecoTEC plus system boilers	33
3.10.4	Pressure gauge	16	5.4.4	Filling the heating system for the first time... ..	33
3.10.5	Expansion vessel	16	5.5	Initial system flush ("cold").....	33
3.11	Pump specifications	17	5.6	Filling the condensate siphon	34
3.11.1	Circulating pump	17	5.7	Adjusting the pumping capacity	34
3.11.2	System by-pass	17	5.8	Adjusting the by-pass	34
3.11.3	Venting.....	17	5.9	Checking the gas setting	34
3.12	Condensate trap.....	17	5.9.1	Checking for tightness of the flue gas installation and flue gas recirculation	35
4	Boiler installation sequence	18	5.9.2	Checking the gas flow rate	35
4.1	Transporting the appliance	18	5.9.3	Checking the gas inlet working pressure	36
4.2	Required minimum distances/assembly clearances	19	5.10	Refitting the case.....	38
4.2.1	Select position for boiler	19	5.11	Adjusting the central heating output (range rating).....	38
4.2.2	Unpack the boiler.....	20	5.12	Gas changeover	38
4.2.3	Using boiler template	20			
4.3	Flue exit.....	20			
4.4	Fitting the boiler hanging bracket	20			
4.5	Installing the flue system.....	21			
4.6	Fitting the boiler	21			

6	Functional checks (commissioning part II) . . .	39
6.1	Functional checks	39
6.1.1	Procedure	39
6.1.2	Heating.	39
6.1.3	Water heating (combination boilers only).	39
6.1.4	Final flush of the heating system ("hot")	39
6.2	Handing over to the user	40
6.3	Factory guarantee.	40
7	Inspection and maintenance	41
7.1	Inspection and maintenance intervals.	41
7.1.1	General inspection and maintenance instructions	41
7.1.2	Safety instructions	42
7.1.3	Checking the CO ₂ concentration.	42
7.1.4	Adjusting the CO ₂ concentration (or the air ratio)	43
7.1.5	Inspection and maintenance work steps.	44
7.2	Servicing the burner module.	45
7.2.1	Removing the burner module	45
7.2.2	Cleaning the integral condensation heat exchanger	46
7.2.3	Checking the burner	46
7.2.4	Refitting the burner module	46
7.3	Cleaning the condensate siphon.	47
7.4	Checking the expansion vessel	48
7.5	Recommissioning the boiler.	48
7.6	Test operation	48
8	Troubleshooting.	49
8.1	Logical fault finding procedure.	49
8.1.1	Status codes	49
8.1.2	Diagnostic codes	49
8.1.3	Fault codes	52
8.1.4	Fault memory	52
8.2	Test programs	54
8.3	Resetting parameter to factory settings.	54
9	Parts replacement	54
9.1	Safety instructions	54
9.2	Replacing burner	55
9.3	Replacing fan or gas valve.	55
9.4	Replacing expansion vessel	56
9.5	Replacing primary heat exchanger	56
9.6	Replacing electronics and display	57
10	Recycling and disposal	58
11	Vaillant service	58
Appendix		
	EG declaration of conformity	59
	Benchmark gas boiler commissioning checklist	60

1 Introduction

1.1 Notes on the documentation

The following information is intended to help you throughout the entire documentation.

Further documents apply in combination with this installation and maintenance manual.

We assume no liability for any damage caused by non-observance of these manuals.

1.1.1 Applicable documents

- Always observe all installation instructions for structural parts and components of the system when installing the ecoTEC plus 937. These installation instructions are enclosed with the various system components as well as additional components.
- Also observe all the operating instructions included with the system components.

1.1.2 Retention of documents

Pass on this installation manual to the owner of the system. The owner should retain the manuals so that they are available when required.

1.1.3 Safety instructions and symbols

Observe the safety instructions in this manual for the installation of the appliance!

Symbols used in the manual are explained below:

 **Danger!**
Immediate danger to life and limb!

 **Danger!**
Risk of death from electric shock!

 **Danger!**
Risk of burns or scalding!

 **Caution!**
Potentially dangerous situation for the product and environment!

 **Note**
Useful information and instructions.

- Symbol for a necessary task

1.2 Validity of the manual

This installation manual applies exclusively to units with the following part numbers:

- 0010004108	- 308525
- 308511	- 308526
- 308520	- 308527
- 308521	- 308528
- 308522	- 308531
- 308523	- 308534
- 308524	- 308536

The part number of the unit can be obtained from the identification plate.

1.3 Introduction



Note

This boiler must be installed and serviced by a competent person approved at the time by the Health and Safety executive and in accordance with the Gas Safety (Installation and Use) Regulations 1998.

ecoTEC combination boiler

The ecoTEC combination boiler is a fully automatic, wall mounted, room sealed condensing (high efficiency) boiler for central heating and domestic hot water. Domestic hot water is supplied directly from the boiler, without requiring a copper cylinder, cold water tank, feed and expansion vessel and associated pipework. Domestic hot water has priority over central heating. The ecoTEC plus combination boiler consists of 3 models with outputs of 23 kW, 31 kW and 37 kW for domestic hot water and two pro versions with outputs of 24 kW and 28 kW for domestic hot water.

All versions are available in natural gas. The ecoTEC plus 831 is also available in LPG.

ecoTEC combination boilers incorporate a warm start facility that keeps the domestic hot water heat exchanger hot, providing an instantaneous delivery of domestic hot water. The temperature in the domestic hot water heat exchanger is limited by the boiler control system and it is not necessary to install a scale reducer on the cold mains to the boiler. However, in areas that get exceptionally hard water, a scale reducer may be fitted to prevent scale formation in the hot water system pipes. The heating system on ecoTEC plus combination boilers can be filled using the built-in filling loop contained within the boiler.

ecoTEC system boiler

The ecoTEC system boiler is a fully automatic, wall mounted, room sealed condensing (high efficiency) boiler for central heating and domestic hot water (where a separate indirect hot water storage cylinder is also incorporated in the system).

The ecoTEC system boiler consists of models with outputs of 12, 15, 18, 24, 30 and 37 kW. All ecoTEC system boilers are available in Natural Gas. The ecoTEC plus 618 and 630 are also available in LPG.

1.4 General Notes

The boilers have been designed for use with a sealed central heating system, and come fully tested and assembled with a built in circulating pump, expansion vessel and diverter valve (ecoTEC combination boilers). The boilers are easily mounted on any internal wall and can be installed with either a horizontal or vertical RSF (room sealed fan assisted) flue.

The boilers use a standard flue system (100 mm or 125 mm outside diameter). Flue extensions and additional bends and elbows are available for the flue system to increase the flexibility. If desired, an inhibitor may be used in the system. Guidance on the use of inhibitors is contained in these instructions.

All boilers have a built in diagnostic system which indicates the operational status of the boiler. This feature provides key information to aid commissioning and fault finding. The data badge is fitted to the underside of the boiler. See text of General Requirements for installation requirements or notes.

1.5 Intended use

The Vaillant ecoTEC are state-of-the-art appliances which have been constructed in accordance with recognised safety regulations. Nevertheless, danger to the life and limb of the user or third parties can still occur or the appliance or other material assets be impaired in the event of improper use.

The unit is not intended for use by persons (including children) with reduced physical, sensory or mental capabilities, or lack of experience and/or knowledge, unless they have been given supervision or instruction concerning use of the unit by a person responsible for their safety.

Children must be watched to ensure that they do not play with the unit.

The appliance is designed to generate heat for connecting to hot water central heating systems and for instantaneous hot water supply (ecoTEC combination boilers only). Any other use or extended use is considered to be improper. The manufacturer or supplier is not liable for any resulting damage. The user alone bears the risk.

Intended use includes the observance of the operating and installation manual and the adherence to the inspection and maintenance conditions.



Caution!

Any incorrect use is forbidden.

The appliances must be installed by a competent person approved at the time by the Health and Safety executive, who is responsible for adhering to the existing regulations, rules and guidelines.

1.6 CE marking



The CE marking shows that the appliances comply with the basic requirements of the following directives:

- Gas appliances directive (90/396/EEC)
- Electromagnetic compatibility directive with threshold class B (89/336/EEC)
- Low voltage directive (73/23/EEC)

The appliances satisfy the basic requirements of the efficiency directive (92/42/EEC) as condensing appliance.

- The Gas Appliance (Safety) Regulations 1992
- The boiler (Efficiency) Regulations 1993



Vaillant Ltd. supports the Benchmark initiative. At the rear of this guide, you will find a Benchmark gas boiler commissioning checklist. It is very important that this is completed correctly at the time of installation, commissioning and hand over to the user.

1.7 Gas council numbers

Appliance	Gas council numbers
ecoTEC pro 24	47-044-36
ecoTEC pro 28	47-044-30
ecoTEC plus 824	47-044-31
ecoTEC plus 831	47-044-32
ecoTEC plus 831 Propane	47-044-34
ecoTEC plus 837	47-044-33
ecoTEC plus 612	41-044-44
ecoTEC plus 615	41-044-45
ecoTEC plus 618	41-044-46
ecoTEC plus 618 Propane	41-044-51
ecoTEC plus 624	41-044-47
ecoTEC plus 630	41-044-48
ecoTEC plus 630 Propane	41-044-50
ecoTEC plus 637	41-044-49

Table 1.1 Gas council numbers

2 Boiler specifications

2 Boiler specifications

2.1 Technical data

Technical data	ecoTEC plus			ecoTEC pro		Units
	824	831	837	24	28	
CH heat output range						
80 °C flow/60 °C return	6.7 - 19.0	8.7 - 24.0	12.0 - 28.0	6.7 - 19.0	9.0 - 24.0	kW
60 °C flow/40 °C return	6.9 - 19.6	9.0 - 24.7	12.3 - 28.9	6.9 - 19.6	9.3 - 24.7	kW
50 °C flow/30 °C return	7.1 - 20.2	9.2 - 25.5	12.7 - 29.7	7.1 - 20.2	9.6 - 25.5	kW
40 °C flow/30 °C return	7.2 - 20.6	9.4 - 26.0	12.9 - 30.3	7.2 - 20.6	9.8 - 26.0	kW
Maximum DHW output	23.0	31.0	37	23.0	28.0	kW
Maximum output for heating	19	24	28	19	24	kW
Minimum output	6.7	8.7	12	6.7	9.0	kW
Category	II _{2H3P}					
SEDBUK Band	A	A	A	A	A	Band
SAP Seasonal Efficiency	91.1					%
Inlet gas working pressure required (G20, natural gas)	20					mbar
Inlet gas working pressure required (G31, Propane)	37					mbar
Connected load (if needed, related to stored charge/ water heating) at 15 °C and 1013 mbar	G20: 2.5 G31: 1.82	G20: 3.3 G31: 2.46	G20: 4.0 G31: 2.94	G20: 2.5 G31: 1.82	G20: 3.0 G31: 2.22	m ³ /h kg/h
Exhaust mass rate						
at minimum thermal load (40 °C flow/30 °C return)	3.2	4.2	5.7	3.2	4.4	g/s
at maximum thermal load (80 °C flow/60 °C return)	10.7	14.4	17.1	10.7	13.0	g/s
Exhaust temperature						
at minimum thermal load (40 °C flow/30 °C return)	40	40	40	40	40	°C
at maximum thermal load (80 °C flow/60 °C return)	74	83	70	74	74	°C
NOx class	5					
Protection class	IP X4D					
max. flow temperature	85					°C
Adjustable flow temperature						
Default setting: max. 75 °C	30 - 85		40 - 85	30 - 85		°C
Maximum CH system pressure	3.0					bar
Circulation water volume (ΔT=20 K)	817	1032	1204	817	1032	l/h
Approx. condensation volume						
at 50 °C flow/30 °C return heating	1.8	2.2	2.9	1.8	2.2	l/h
Pump delivery height	250					mbar
Minimum DHW flow rate	1.5					l/min
DHW flow rate ΔT=35 K rise	9.4	12.7	15.2	9.4	11.5	l/min
Appr. DHW flow rate at factory set temp. rise (ΔT=42 K)	7.9	10.6	12.6	7.9	9.6	l/min
Permitted DHW overpressure	10					bar
Mains water pressure required for max. flow rate	0.5	0.75	0.75	0.5	0.5	bar
Mains water pressure required for min. flow rate	0.15					bar
Hot water discharge temperature range	35 - 65					°C
Exhaust flue	60/100					mm
Flue categories	C13, C33, C43, C53, C83, B23, B33					
10 l expansion vessel pre-charge pressure	0.75					bar
Connections heating flow/return	22					mm
Gas inlet	15		22	15		mm
Pressure relief discharge pipework (min.)	15					mm
Condensate drain (min. internal drain)	19					mm
Dimensions (H x W x D)	720 x 440 x 335	720 x 440 x 335	720 x 440 x 403	720 x 440 x 335	720 x 440 x 335	mm
Weight (boiler only)	35	38	44,5	34	37	kg
Primary water content	1.9	2.3	2.5	1.9	2.1	l
Electrical supply voltage	230/50					V ~/Hz
Internal fuse (slow) main voltage	2					A
Power input	110	125	140	110	115	W

Table 2.1 Technical data ecoTEC combination boiler

Technical data	ecoTEC plus						Units
	612	615	618	624	630	637	
CH heat output range							
80 °C flow/60 °C return	4.9 - 12.0	4.9 - 15.0	6.7 - 18.0	8.7 - 24.0	10.0 - 30.0	12.0 - 37.0	kW
60 °C flow/40 °C return	5.1 - 12.3	5.1 - 15.5	6.9 - 18.6	9.0 - 24.7	10.3 - 30.9	12.3 - 38.2	kW
50 °C flow/30 °C return	5.2 - 12.7	5.2 - 15.9	7.1 - 19.1	9.2 - 25.5	10.6 - 31.8	12.7 - 39.3	kW
40 °C flow/30 °C return	5.3 - 12.9	5.3 - 16.2	7.2 - 19.5	9.4 - 26.0	10.8 - 32.4	12.9 - 40.1	kW
Category	II _{2H3P}						
SEDBUK Band	A	A	A	A	A	A	Band
SAP Seasonal Efficiency	91.2						%
Inlet gas working pressure required (G20, natural gas)	20						mbar
Inlet gas working pressure required (G31, Propane)	37						mbar
Connected load (if needed, related to stored charge/water heating) at 15 °C and 1013 mbar	G20: 1.3 G31: 0.95	G20: 1.6 G31: 1.19	G20: 1.9 G31: 1.43	G20: 2.6 G31: 1.90	G20: 3.2 G31: 2.38	G20: 4.0 G31: 2.94	m ³ /h kg/h
Exhaust mass rate at minimum thermal load (40 °C flow/30 °C return)	2.3	2.3	3.2	4.2	4.8	5.7	g/s
Exhaust mass rate at maximum thermal load (80 °C flow/60 °C return)	5.6	7.0	8.3	11.2	13.9	17.1	g/s
Exhaust temperature at minimum thermal load (40 °C flow/30 °C return)	40			40	40	40	°C
Exhaust temperature at maximum thermal load (80 °C flow/60 °C return)	70			75	83	70	°C
NOx class	5						
Protection class	IP X4D						
max. flow temperature	85						°C
Adjustable flow temperature Default setting: max. 75 °C	30 - 85						°C
Maximum CH system pressure	3.0						bar
Circulating water volume (ΔT=20 K)	516	645	774	1032	1290	1591	l/h
Approx. condensation volume at 50 °C flow/30 °C return heating	1.1	1.4	1.7	2.2	2.7	3.8	l/h
Pump delivery height	250					150	mbar
Adjustable storage target value (15 °C at left stop, spare adjusting range 40 - 70 °C)	15 - 70						°C
Exhaust flue	60/100						mm
Flue categories	C13, C33, C43, C53, C83, B23, B33						
10 l expansion vessel pre-charge pressure	0.75						bar
Connections heating flow/return	22						mm
Gas inlet	15					22	mm
Pressure relief discharge pipework (min.)	15						mm
Condensate drain (min. internal drain)	19						mm
Dimensions (H x W x D)	720 x 440 x 335				720 x 440 x 369	720 x 440 x 403	mm
Weight (boiler only)	35	35	35	37	38	40	kg
Primary water content	1.9	1.9	1.9	2.1	2.3	2.5	l
Electrical supply voltage	230/50						V ~/Hz
Internal fuse (slow) main voltage	2						A
Power input	100	110	100	110	110	140	W

Table 2.2 Technical data ecoTEC system boiler

2 Boiler specifications

2.2 Dimensions

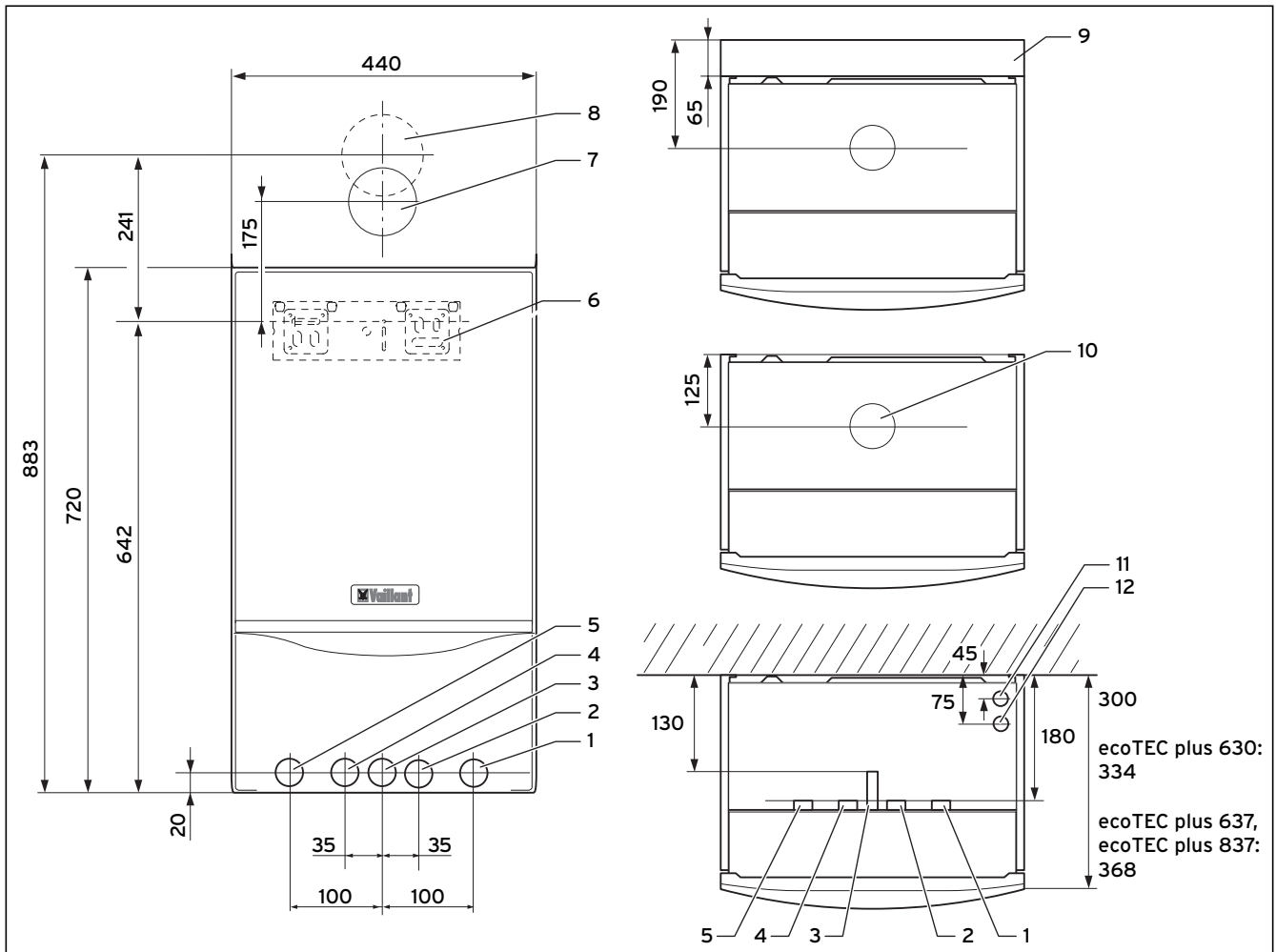

Fig. 2.1 Dimensions in mm

Legend:

- 1 Heating return pipe \varnothing 22 mm
- 2 Cold water connection \varnothing 15 mm (combination boilers only)
- 3 Gas connection \varnothing 15 mm
- 4 Hot water connection \varnothing 15 mm (combination boilers only)
- 5 Heating flow pipe \varnothing 22 mm
- 6 Hanging bracket
- 7 Flue hole - flue system 60/100
- 8 Flue hole - flue system 80/125
- 9 Spacer frame accessory (Art. No.: 308 650)
- 10 Flue pipe connection
- 11 Condensate drain connection (\varnothing 19 mm)
- 12 Heating system expansion relief valve connection (\varnothing 15 mm)



Note

With the spacer frame (Art. No 308 650), the pipes can be run behind the boiler. The distance of the appliance from the wall thus increases by 65 mm.

2.3 Installation

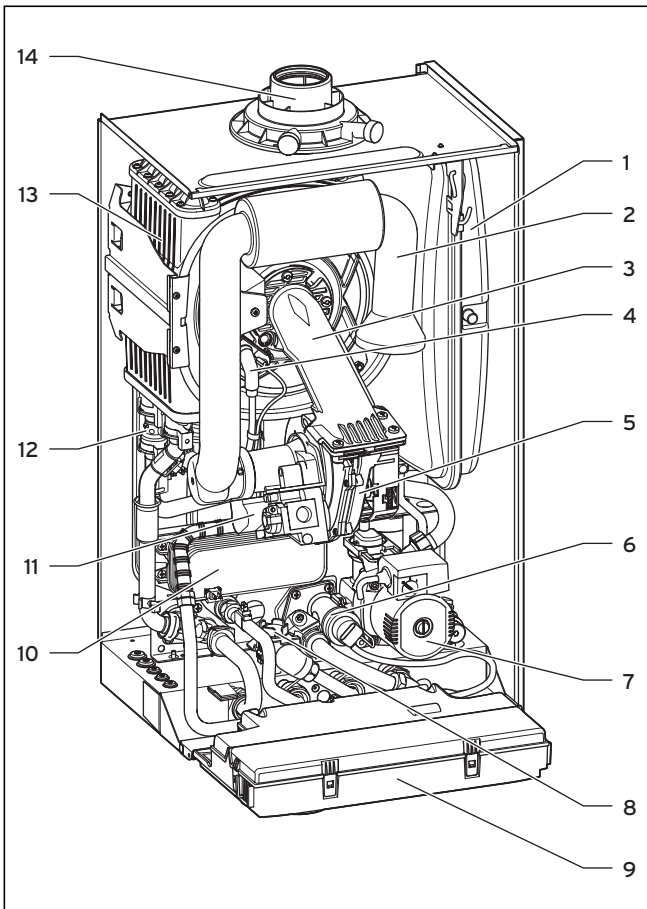

Fig. 2.2 Function elements of combination boilers

Legend:

- 1 Expansion vessel
- 2 Air intake pipe
- 3 Burner module
- 4 Ignition electrode
- 5 Fan
- 6 Diverter valve with by-pass
- 7 Pump
- 8 Aqua-Sensor
- 9 Electronics box
- 10 Hot water heat exchanger
- 11 Gas valve
- 12 Pressure sensor
- 13 Heat exchanger
- 14 Flue pipe connection

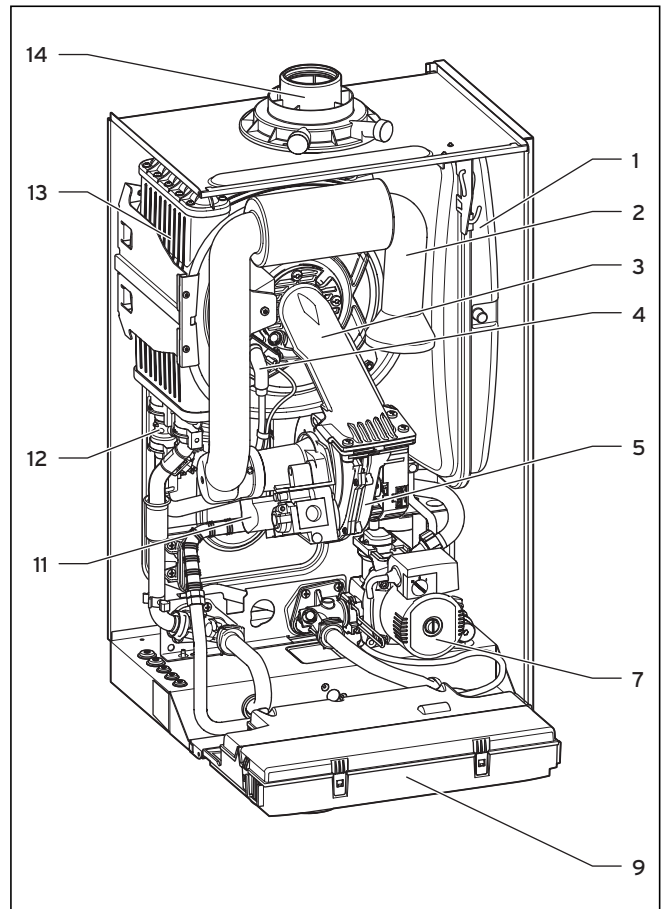

Fig. 2.3 Function elements of system boilers

Legend:

- 1 Expansion vessel
- 2 Air intake pipe
- 3 Burner module
- 4 Ignition electrode
- 5 Fan
- 7 Pump
- 9 Electronics box
- 11 Gas valve
- 12 Pressure sensor
- 13 Heat exchanger
- 14 Flue pipe connection

2.4 Type plate

The type plate of the Valliant ecoTEC is attached to the bottom of the appliance at the factory.

3 General requirements

3 General requirements

3.1 Preliminary remarks for room sealed appliances

This appliance should only be installed in conjunction with either a Vaillant flue system or an alternative approved system (details of flue approval categories can be found in the technical section of the installation manual). Install the flue system as detailed in the separate flue installation instructions supplied with this boiler.

3.2 Related documents

The installation of the appliance and any associated hot water system must be in accordance with (but not limited to) the following; COSHH regulations, Gas Safety (Installation and Use) Regulations 1998, Health and Safety Document No. 635 (The Electricity at Work Regulations 1989), BS7671 (IEE Wiring Regulations) and the Water Supply (Water Fitting) Regulations 1999, or The Water Bylaws 2000 (Scotland). It should also be in accordance with the relevant requirements of the Local Authority, Building Regulations, The Building Regulations (Scotland), The Building Regulations (Northern Ireland) and the relevant recommendations of the following British Standards:

BS 6700: Services supplying water for domestic use within buildings and their curtilages.

BS 6798: Specification for installation of gas fired boilers not exceeding 60 kW input.

BS 6891: Specification for installation of low pressure gas pipework up to 28 mm (R1) in domestic premises (2nd family gas).

BS 7593: Treatment of water in domestic hot water central heating systems.

Institute of Gas Engineers Publication **IGE/UP/7/1998:** "Guide for gas installations in timber framed housing"

BS. 5482 Pt. 1 Domestic butane and propane gas burning installations.

IGE/UP1 Soundness testing and purging of industrial and commercial gas installation.

IGE/UP2 Gas installation pipework, boosters and compressors on industrial and commercial premises.

IGE/UP10 Installation of gas appliances in industrial and commercial premises.

BS. 6644: Installation of gas fired hot water boilers of rated inputs between 60 kW and 2 MW (2nd and 3rd family gases).

BS. 5449: Forced circulation hot water central heating systems for domestic premises. Note: only up to 45 kW.

BS. 6880: Low temperature hot water heating systems of output greater than 45 kW.

Part 1 Fundamental and design considerations.

Part 2 Selection of equipment.

Part 3 Installation, commissioning and maintenance.

BS. 4814: Specification for: Expansion vessels using an internal diaphragm, for sealed hot water heating systems.

BS. 5440: Installation and maintenance of flues and ventilation for gas appliances of rated input not exceeding 70 kW net (1st, 2nd and 3rd family gases).

Part 1 Specification for installation of flues.

Part 2 Specification for installation and maintenance of ventilation for gas appliances.

European installation directive



Caution!

The appliance must be installed and serviced by a competent person approved at the time by the Health and Safety Executive and in accordance with the Gas Safety (Installation and Use) Regulations 1998. In IE, the installation must be in accordance with the current edition of I.S.813 'Domestic Gas Installations', the current Building Regulations and reference should be made to the current ETCI rules for electrical installation.



Caution!

When tightening or slackening screwed connections always use suitable open-ended spanners (not pipe wrench, or extensions, etc.). Incorrect use and/or unsuitable tools can lead to damage being caused (e.g. gas or water leakage)!

3.3 Contents included with delivery

The Vaillant ecoTEC is delivered pre-mounted in a package unit. Check that all the parts have been delivered intact (see Fig. 3.1 and Table 3.1, Fig. 3.2 and Table 3.2 and Fig. 3.3 and Table 3.3).

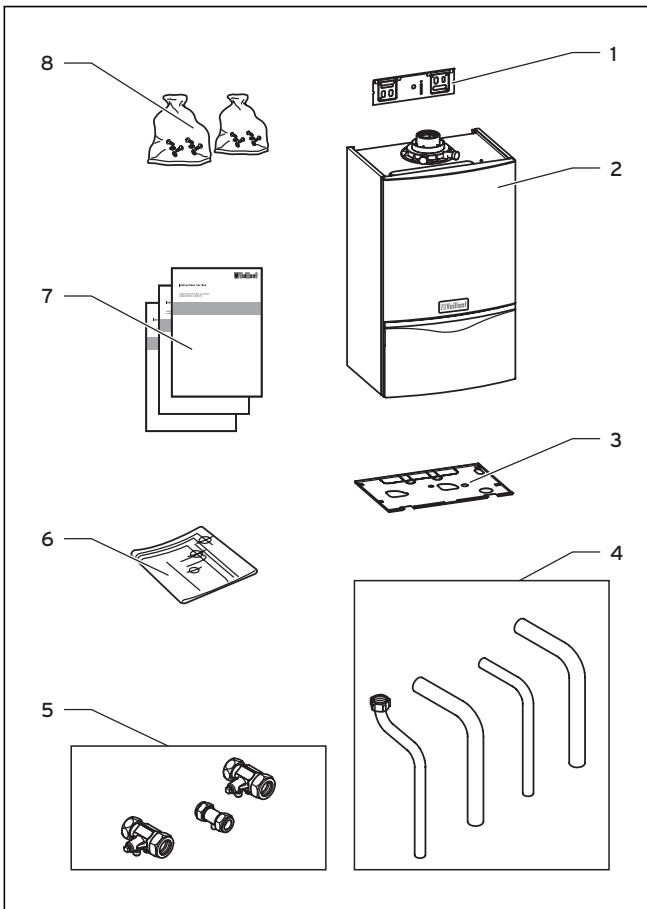

Fig. 3.1 Contents included with delivery of ecoTEC plus system boilers

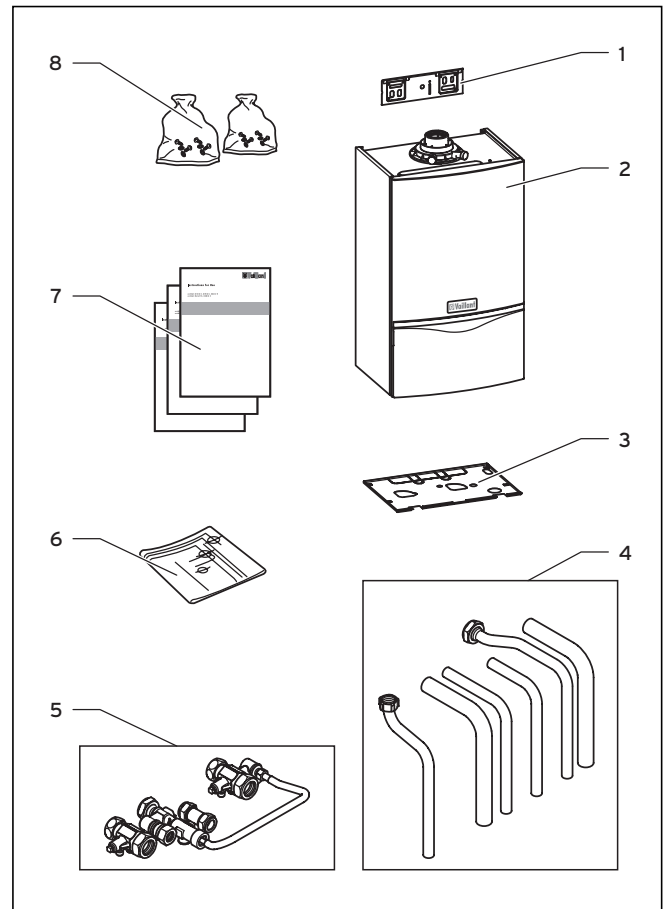

Fig. 3.2 Contents included with delivery of ecoTEC plus combination boilers

DO NOT remove the boiler from the polystyrene base at this stage.

DO NOT remove the boiler from the polystyrene base at this stage.

Item	Quantity	Description
1	1	Hanging bracket
2	1	Boiler
3	1	Bottom cover
4	4	Connecting pipes (gas, heating, safety valve)
5	3	Isolating valves
6	1	Template
7	3	User, installation and service and flue installation manuals
8	2	Installation and connection accessories
	2	For LPG appliances, extra: 1 sticker each for tank and ventilation (above Fig.)

Table 3.1 Contents included with delivery of ecoTEC plus system boilers

Item	Quantity	Description
1	1	Hanging bracket
2	1	Boiler
3	1	Bottom cover
4	6	Connecting pipes (gas, heating, water, safety valve)
5	4	Isolating valves and filling loop
6	1	Template
7	3	User, installation and service and flue installation manuals
8	2	Installation and connection accessories
	2	For LPG appliances, extra: 1 sticker each for tank and ventilation (above Fig.)

Table 3.2 Contents included with delivery of ecoTEC plus combination boilers

3 General requirements

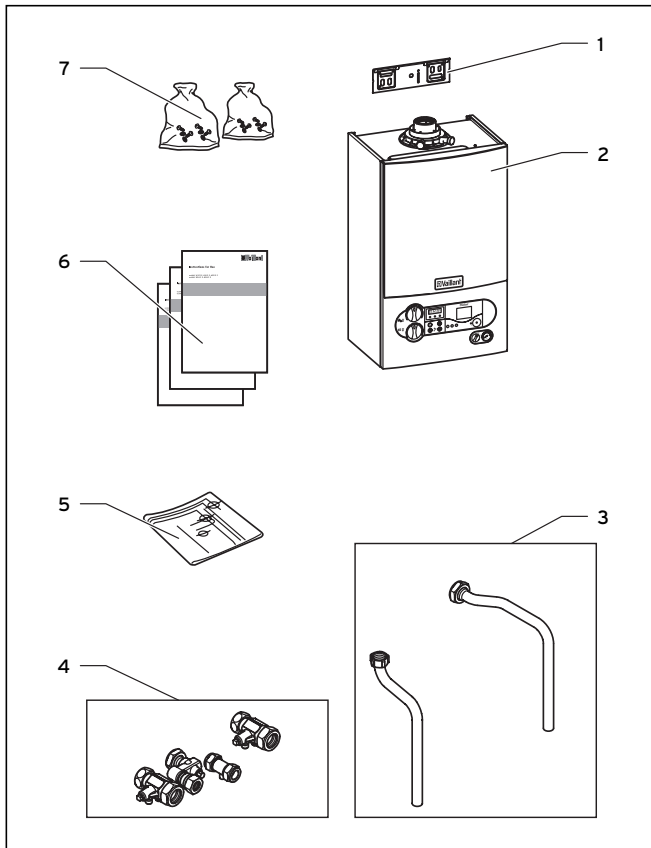

Fig. 3.3 Contents included with delivery of ecoTEC pro combination boilers

DO NOT remove the boiler from the polystyrene base at this stage.

Item	Quantity	Description
1	1	Hanging bracket
2	1	Boiler
3	2	Connecting pipes (hot water, heating safety valve)
4	4	Isolating valves
5	1	Template
6	1	User, installation and service and flue installation manuals
7	2	Installation and connection accessories

Table 3.3 Contents included with delivery of ecoTEC pro combination boilers

3.4 Installation site

The location chosen for the boiler must permit the provision of a satisfactory flue termination. The location must also provide adequate space for servicing and air circulation around the boiler. The boiler may be installed in any room, although particular attention is drawn to the requirements of BS7671 (IEE Regulations), the electrical provisions of the Building Standards (Scotland) Regulations, and in IE the current edition of IS 813 and the current ETCI rules, in respect of the installation of a boiler in a room containing a bath or shower.

Note
If a room sealed boiler is installed in a room with a bath or shower, electrical switches or boiler controls using the mains power supply must be placed at locations that cannot be reached by the person in the bath or shower.

Note
If the boiler is to be installed in an airing cupboard it is not required to separate the boiler with a non-combustible partition. However installation and servicing clearances must be maintained, and the appliance kept clear of any clothing.

If the boiler is installed in an unusual location, special procedures may be necessary and BS 5546 and BS 6798 give detailed guidance on this aspect. The boiler must be mounted on a flat, vertical wall, which must be sufficiently robust to take the weight of the boiler. The boiler may be installed on a combustible wall, subject to the requirements of the Local Authorities and Building Regulations. A compartment used to enclose the boiler must be designed and constructed specifically for this purpose. (An existing cupboard or compartment may be used provided that it is modified for the purpose). Details of essential features of cupboard/compartment design including airing cupboard installations are given in BS 6798. If the boiler is to be fitted in a timber framed building, it should be fitted in accordance with Institute of Gas Engineers Publication „IGE/UP/7 Edition 2 Gas installations in timber framed and high steel framed buildings“. Note the safety instructions below before deciding where to install the boiler:

Caution!
Do not install the appliance in rooms prone to frost. In rooms with aggressive steam or dust, the appliance must be operated independent of the ambient air.

When choosing the place of installation and while operating the appliance, make sure that the air supply is free of chemical substances containing fluorine, chlorine, sulphur etc. Sprays, solvents and cleaning agents, paints, adhesives etc. contain the kind of substances that can lead to corrosion even in the exhaust system when the appliance is operated depending on the ambient air in the worst case scenario. Particularly in hair-cutting salons, lacquering and finishing, cleaning facilities, the appliance must be operated independent of the ambient air! Otherwise, a separate installation room is required to guarantee that the air supply is free of the above mentioned substances.

3.5 Gas supply

The gas supplier should ensure the availability of an adequate supply of gas. A gas meter may only be connected to the service pipe by the supplier of gas or

their contractor. An existing meter should be checked to ensure that it is capable of passing the rate of gas supply required. Installation pipes should be fitted in accordance with BS 6891. In IE the current edition of IS 813. Pipework from the meter to the boiler must be of an adequate size. Do not use pipes of a smaller size than the boiler gas connection (15 mm). The complete installation must be checked for leaks and purged as described in BS 6891.

3.6 Flue pipe



Danger!

Vaillant appliances are certified only for use with genuine Vaillant flue pipes. Only use genuine Vaillant flue pipes. Malfunctions can occur if you use other accessories. These may result in damage and injury. You will find a list of genuine flue pipes in the Vaillant installation manual for flue pipes.

The CE mark is valid only if the appliance is operated with Vaillant flue pipes.

3.6.1 Standard 100 mm flue system

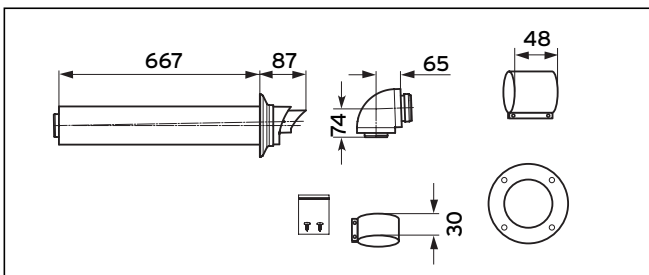

Fig. 3.4 Art. No. 303 933

A standard 100 mm flue system (Art. No. 303 933) is available. Refer to flue system installation instructions for full details.

Flue extensions are available to extend this length up to 8 m. Both 90° bends and 45° elbows are also available to increase siting flexibility.

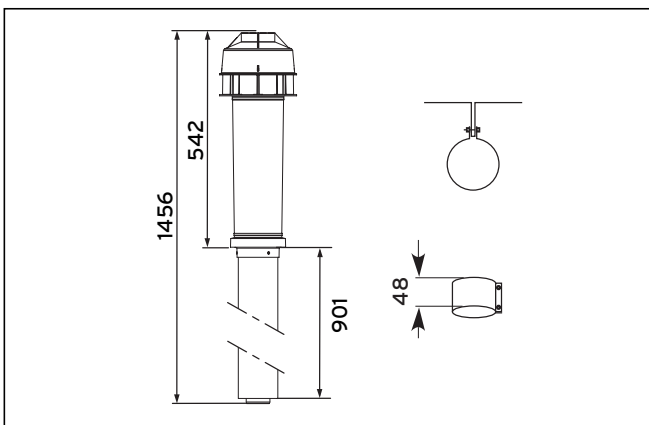

Fig. 3.5 Art. No. 0020060570

3.6.2 Optional 125 mm flue system

A concentric flue system of 125 mm outside diameter is available and can be used to achieve flue lengths up to 25 m.

A vertical flue system is also available. Refer to flue system installation instructions for full details.

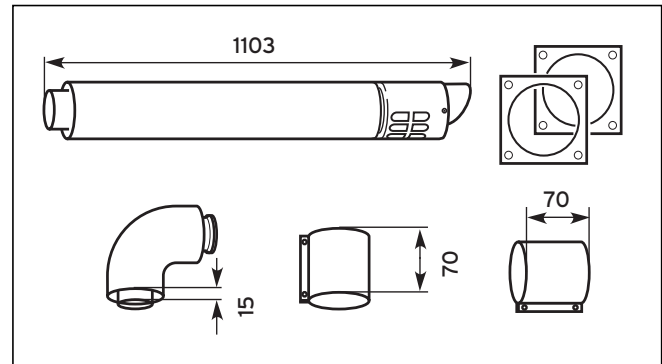

Fig. 3.6 Art. No. 303 209

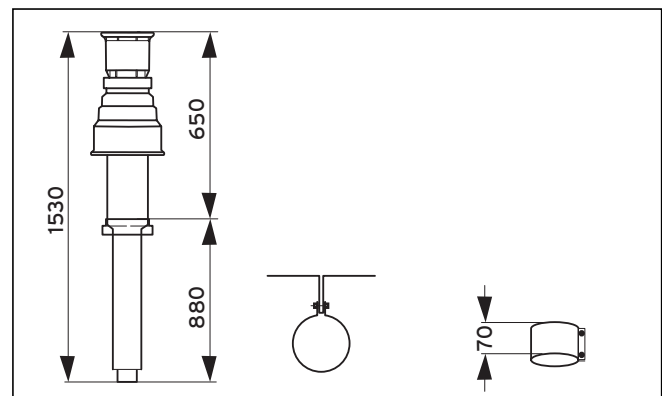

Fig. 3.7 Art. No. 303 200

3.7 Flue termination

The following details refer to both flue systems.

- The terminal must be located where the combustible substances can escape freely at all times.
- A plume of water vapour will sometimes be visible from the flue terminal. Positions where this could be a nuisance should be avoided.
- If the terminal is fitted less than 2 m above a balcony, above ground or above a flat roof to which people have access then a suitable terminal guard must be provided and fitted (made by Tower Flue Components, Tonbridge, TN9 1TB, Model K3, plastic coated).

3 General requirements

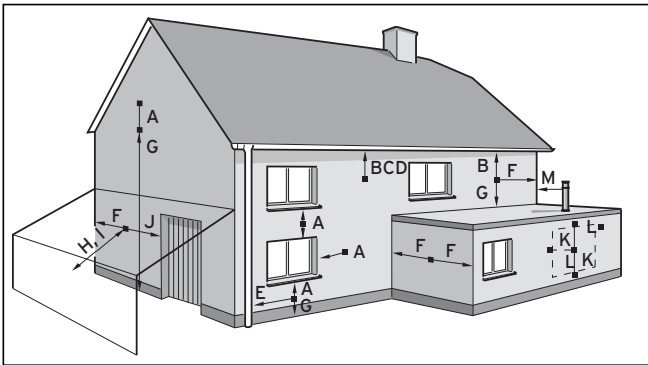

Fig. 3.8 Flue termination

Note
Vertical flues must not terminate within 600 mm of an openable window, air vent or any other ventilation opening.

The flue assembly shall be so placed or shielded as to prevent ignition or damage to any part of the building.

	Terminal position	mm
A	Directly below an opening, above an opening or horizontal to an opening, air brick, opening window, etc.	300
B	Below gutters, soil pipes or drain pipes	75
C	Below eaves	200
D	Below balconies	200
E	From vertical drain pipes and soil pipes	25
F	From internal or external corners	300
G	Above ground, roof or balcony	300
H	From a surface facing a terminal	600
I	From a terminal facing a terminal	1200
J	From an opening in the car port (e.g. door, window) into the dwelling	1200
K	Vertically from a terminal on the same wall	1500
L	Horizontally from a terminal on the same wall	300
M	Distance from adjacent for vertical Flue	500

Table 3.4 Terminal position for a fan assisted concentric flue

Note
In addition, the terminal should not be nearer than 150 mm to an opening in the building fabric formed for the purpose of accommodating a built-in element such as a window.

BS5440-1: It is recommended that the fanned flue terminal should be positioned as follows:

- a) at least 2 m from an opening in the building directly opposite, and
 - b) so that the products of combustion are not directed to discharge across a boundary.
- 1) Dimensions B, C and D:
 These clearances may be reduced to 25 mm without affecting the performance of the boiler.

In order to ensure that the condensate plume does not affect adjacent surfaces the terminal should be extended as shown in Fig. 3.9.

- 2) Dimension F:
 This clearance may be reduced to 25 mm without affecting the performance of the boiler. However, in order to ensure that the condensate plume does not affect adjacent surfaces a clearance of 300 mm is preferred. For IE, recommendations are given in the current edition of IS 813.

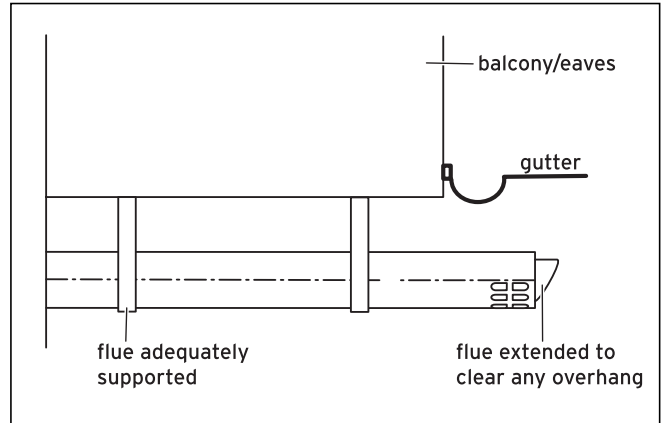

Fig. 3.9 Flue termination under balcony/eaves

3.8 Air supply

Detailed recommendations for air supply are given in BS 5440: Part 2.

It is not necessary to have an air vent in the room or internal space in which the boiler is installed.

Cupboard or compartment ventilation

The boilers are very high efficiency appliances. As a consequence the heat loss from the appliance casing during operation is very low. For cupboard or compartment installations it is therefore not necessary to provide any high or low level permanent air vents for cooling purposes.

3.9 Electrical supply

A 230 V, ~ 50 Hz single phase electricity supply fused to 3 Amp. must be provided in accordance with the latest edition of BS 7671 (IEE Wiring Regulations) and any other local regulations that may apply. In IE reference should be made to the current edition of the ETCI rules. The method of connection to the mains electricity supply must provide a means of completely isolating the boiler and its ancillary controls. Isolation is preferably by the use of a fused three pin plug and unswitched shuttered socket outlet, both complying with the requirements of BS 1363. Alternatively, a 3 Amp. fused double pole switch with a 3 mm contact separation on both poles may be used.



Danger!
This appliance must be earthed.

3.10 Guide to system requirements

3.10.1 Water circulation system

Detailed recommendations for the water circulation system are given in BS 6798 and BS 5449: Part 1 (for small bore and micro bore central heating systems). Pipework not forming part of the useful heating surface should be insulated to help prevent heat loss and possible freezing, particularly where pipes are run through roof spaces and ventilated underfloor spaces. Draining taps must be located in accessible positions which permit the draining of the whole system including the boiler and the hot water system. Draining taps should be at least 1/2 in. BSP nominal size and be in accordance with BS 2879.

The boiler is suitable for use with minibore or microbore systems. Copper tubing to BS 2871: Part 1 should be used for water carrying pipework. All capillary joints in all DHW pipework must be made with lead free solder. Particularly where a new boiler is to be fitted to an existing system, it is good practice that the system is thoroughly cleansed.



Caution!

To prevent the formation of deposits and prevent serious damage to the appliance and system, cleansers must be used carefully and must be completely removed by thoroughly flushing the system. Cleansers should only be left in systems for a maximum of 24 hours.

This cleansing must take place prior to the fitting of the new boiler and be in accordance with BS 7593. For advice on the application of system cleansers contact Sentinel, Betz Dearborn Ltd. Widnes, Cheshire, WA8 8UD. Tel: 0151 420 9595, or Fernox, Alpha Fry Technologies, Tandem House, Marlow Way, Croydon, CR0 4XS. Tel 0870 8700362.

3.10.2 Filling and preparing heating system

The system can be filled using the built in filling loop (ecoTEC plus combination boilers only) or via a separate filling point fitted at a convenient position on the heating circuit. The connection must be removed when filling is completed. Where local Water Authority regulation does not allow temporary connection, a sealed system filler pump with break tank must be used. The heating system will not be filled automatically from the domestic hot water side. (Alternative methods of filling sealed systems are given in BS 5449).

Mixing additives with the heating water can result in material damage. However, up to now, no incompatibility with Vaillant appliances has been detected with proper use of the following products.

- When using additives, follow the additive manufacturer's instructions without exception.

Vaillant accepts no liability for the compatibility of any additive or its effectiveness in the entire heating system.

Additives for cleaning purposes (subsequent flushing required)

- Fernox F3
- Jenaqua 200
- Jenaqua 300
- Jenaqua 400
- Sentinel X 300
- Sentinel X 400

Additives intended to remain permanently in the system

- Fernox F1
- Fernox F2
- Jenaqua 100
- Jenaqua 110
- Sentinel X 100
- Sentinel X 200

Additives for frost protection intended to remain permanently in the system

- Fernox Antifreeze Alphi 11
- Sentinel X 500

- Inform the operator of the necessary measures in case you have used any of these additives.
- Inform the operator of the required procedures for frost protection.
- Observe the applicable national regulations and technical standards for the treatment of filling and top-up water.

Provided the national regulations and technical standards do not specify any higher requirements, the following applies:

- You must treat the heating water
 - if the total volume of filling and top-up water exceeds thrice the nominal volume of the heating system over the service life of the system
 or
 - if the limits given in the following tables are not adhered to.

3 General requirements

Total heating output	Total hardness at 20 l/kW for the smallest boiler heating surface ²⁾	Total hardness at > 20 l/kW < 50 l/kW for the smallest boiler heating surface ²⁾	Total hardness at > 50 l/kW for the smallest boiler heating surface ²⁾
kW	mol/m ³	mol/m ³	mol/m ³
< 50	No requirement or < 3 ¹⁾	2	0,02
> 50 to ≤ 200	2	1,5	0,02
> 200 to ≤ 600	1,5	0,02	0,02
> 600	0,02	0,02	0,02

1) with systems equipped with wall-hung boiler and systems with electric heating elements
 2) of the specific system volume (nominal capacity in litres/heating output; in case of multiple boiler systems the lowest individual heating output should be used)
 These data only apply up to 3x the system volume for filling and top-up water. Once this triple system volume is exceeded, the water will have to be treated exactly the same as in case of exceeding the limit values given in Table 3.6 (softening, desalination, hardness stabilisation and desludging).

Table 3.5 Guidelines for the heating water: Water hardness

Heating water qualities	Unit	Low-salt	saline
Electric conductivity at 25 °C	µS/cm	< 100	100-1500
Appearance		Free of sedimentary substances	
pH-value at 25 °C		8,2-10,0 ¹⁾	8,2-10,0 ¹⁾
Oxygen	mg/L	< 0,1	< 0,02

1) With aluminium and aluminium alloys, the pH value range is restricted from 6.5 to 8.5.

Table 3.6 Guidelines for heating water: Salinity



Caution!

Aluminium corrosion resulting in leakages caused by unsuitable heating water!
 Unlike materials such as steel, cast iron or copper, aluminium is reactive to alkalisied heating water (pH-value > 8,5) which results in significant corrosion.
 With aluminium, ensure that the pH value of the heating water ranges between 6.5 up to a maximum of 8.5.



Caution!

Risk of material damage if the heating water is treated with unsuitable frost or corrosion protection agents!
 Frost and corrosion protection agents may cause changes in the seals, noises during heating and possibly subsequent damage.
 Do not use any unsuitable frost or corrosion protection agents.

3.10.3 Pressure relief valve

A pressure relief valve is provided with the boiler. This safety device is required on all sealed C.H. systems and is preset at 3 bar and provided with a 15 mm compression connection for a discharge pipe, which must be of no less than 15 mm in diameter. The pressure relief valve must not be used for draining purposes.

3.10.4 Pressure gauge

This is factory fitted to the boiler and indicates the primary circuit pressure to facilitate filling and testing.

3.10.5 Expansion vessel

ecoTEC boilers incorporate a 10 litre expansion vessel which is suitable for a sealed heating system with a maximum water content of 100 litres.

If the nominal capacity of the built in expansion vessel is not sufficient for the heating system (for instance in case of modernisation of old open systems) an additional expansion vessel can be installed external to the boiler. It should be fitted in the return pipe as close as possible to the boiler in accordance with BS 5449: Part 1.

Guidance on the sizing of an additional expansion vessel is given in Table 3.7.

	Vessel Volume [L]	
	1.0	1.5
Initial system pressure (bar)	1.0	1.5
Pressure relief valve setting (bar)	3.0	
Total water content of system litres		
25	2.7	3.9
50	5.4	7.8
100	10.9	15.6
125	13.6	19.5
150	16.3	23.4
175	19.1	27.3
200	21.8	31.2
225	24.5	35.1
250	27.2	39.0
275	30.0	42.9
300	32.7	46.8
325	35.7	50.7
350	38.1	54.6
375	40.9	58.5
400	43.6	62.4
425	46.3	66.3
450	49.0	70.2
475	51.8	74.1
500	54.5	78.0
For system volumes other than those given above, multiply the system volume by the factor across	0.109	0.156

Table 3.7 Sizing of additional expansion vessel

3.11 Pump specifications

3.11.1 Circulating pump

only ecoTEC plus:

The circulating pump is included in the boiler. The residual pump discharge height depending on the by-pass valve is shown in Fig. 3.10.1 (ecoTEC plus) and 3.10.2 (ecoTEC plus 637 / 837).

The operating mode of the 2-step pump can be adjusted below the diagnosis number "d.19", see section 8.1.2.

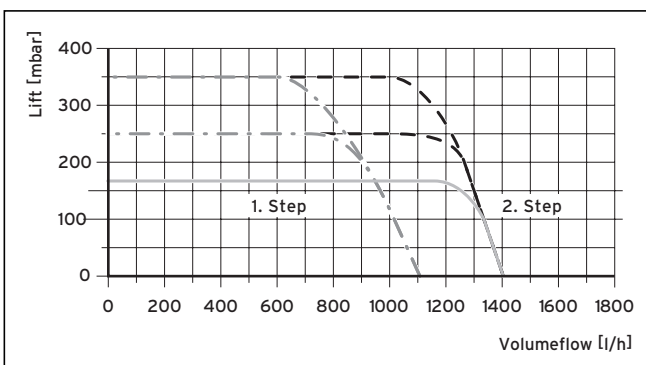

Fig. 3.10.1 Pump specifications ecoTEC plus (except ecoTEC 637 and 837)

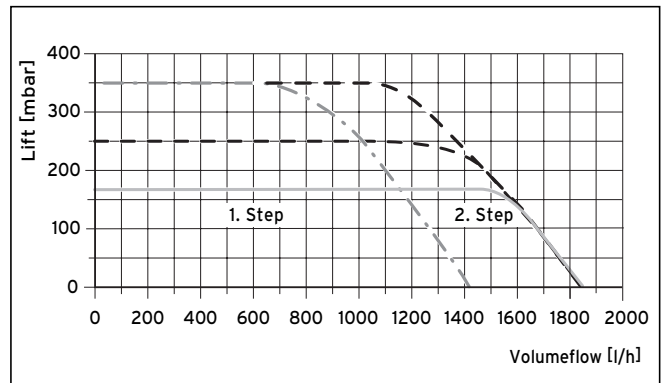

Fig. 3.10.2 Pump specifications only ecoTEC 637 and 837

only ecoTEC pro:

The circulating pump is included in the boiler. The ecoTEC pro appliances are fitted with a single-stage pump. The residual pump discharge height depending on the by-pass valve is shown in Fig. 3.11.

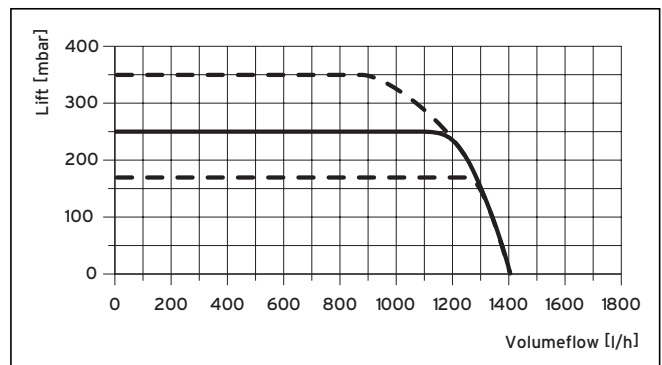

Fig. 3.11 Pump specifications ecoTEC pro

3.11.2 System by-pass

An automatic system by-pass is provided in the boiler. The boiler is suitable for use in systems with thermostatic radiator valves and no additional by-pass is required. The by-pass valve is adjustable, see section 5.3.

3.11.3 Venting

The boiler is fitted with an automatic air vent. Additional provision should be made to enable the heating system to be vented during filling and commissioning either by automatic air vents or manually.

3.12 Condensate trap

The boiler is fitted with a siphonic condensate discharge (ecoTEC plus) or a condensate trap (ecoTEC pro) incorporating a water trap of 140 mm.

4 Boiler installation sequence

4 Boiler installation sequence

4.1 Transporting the appliance



Caution!

With regards to the Manual Handling Operations, 1992 Regulations, the following lift operation exceeds the recommended weight for a one man lift.

General recommendations when handling

Clear the route before attempting the lift. Ensure safe lifting techniques are used - keep back straight - bend using legs. Keep load as close to body as possible. Do not twist - reposition feet instead. If 2 persons performing lift, ensure co-ordinated movements during lift. Avoid upper body/top heavy bending - do not lean forward/sideways. Recommend wear suitable cut resistant gloves with good grip to protect against sharp edges and ensure good grip. Always use assistance if required.

Removal of carton from delivery van

Recommend 2 person lift or 1 person with use of sack truck. If 1 person is performing lift, straddle the load, tilt and place carton into position on truck. Recommend secure appliance onto truck with suitable straps. Ensure safe lifting techniques are used - keep back straight - bend using legs. Keep load as close to body as possible. If 2 persons performing lift, ensure co-ordinated movements during lift. Always use assistance if required.

Carriage of carton from point of delivery to point of installation - ground floor.

Recommend 2 person lift or 1 person with use of sack truck. If 1 person is performing lift, straddle the load, tilt and place carton into position on truck. Recommend secure appliance onto truck with suitable straps. Ensure safe lifting techniques are used - keep back straight - bend using legs. Keep load as close to body as possible. If 2 persons performing lift, ensure co-ordinated movements during lift. Clear the route before attempting the lift. If removing boiler from truck straddle the load and tilt forwards to facilitate secure grip. Ensure safe lifting techniques are used - keep back straight - bend using legs. Do not twist - reposition feet instead. Take care to avoid trip hazards, slippery or wet surfaces and when climbing steps and stairs. Always use assistance if required.

Carriage of carton from point of delivery to point of installation - first or higher floor, cellar.

Recommend 2-person lift or 1 person with use of sack truck. If 1 person is performing lift, straddle the load, tilt and place carton into position on truck. Recommend secure appliance onto truck with suitable straps. Ensure safe lifting techniques are used - keep back straight - bend using legs. Keep load as close to body as possible. If 2 persons performing lift, ensure co-ordinated

movements during lift. Avoid upper body/top heavy bending - do not lean forward/sideways. Clear the route before attempting the lift. If removing boiler from truck straddle the load and tilt forwards to facilitate secure grip. Ensure safe lifting techniques are used - keep back straight - bend using legs. Do not twist - reposition feet instead. Take care to avoid trip hazards, slippery or wet surfaces and when climbing steps and stairs. Always use assistance if required.

Carriage of carton from point of delivery to point of installation - roofspace.

Recommend 2-person lift. Ensure co-ordinated movements during lift. Avoid upper body/top heavy bending - do not lean forward/sideways. Clear the route before attempting the lift. Take care to avoid trip hazards, slippery or wet surfaces and when climbing steps and stairs. When transferring appliance into roofspace, recommend 1 person to be in roofspace to receive the appliance and other person to be below to pass up and support appliance. Ensure safe lifting techniques are used - keep back straight - bend using legs. Keep load as close to body as possible. Always use assistance if required. It is assumed safe access, flooring and adequate lighting are provided in the roof space. It is recommended a risk assessment of the roof space area be carried out before moving the appliance into the area to take into account access, stability of flooring, lighting and other factors, and appropriate measures taken.

Unpacking of appliance from carton.

Recommend 2 persons unpack appliance from carton. Always keep working area clear. Recommend cut base end of carton and open carton flaps, then tilt boiler forwards from its side onto its base and remove carton by sliding up over the boiler. Ensure safe lifting techniques are used - keep back straight - bend using legs. Keep load as close to body as possible. Always use assistance if required. Dispose of packaging in a responsible manner. Recommend wear suitable cut resistant gloves with good grip to protect against sharp edges and ensure good grip when handling appliance outside packaging.

Positioning of Appliance for Final Installation - no obstructions.

This appliance is deemed to be a one person lift when removed from the carton. Fit bracket securely onto wall before lifting appliance into position. Obtain firm grip on front and sides of appliance, lift upwards, ensure stable balance achieved and lift upwards to position in place on bracket. Ensure safe lifting techniques are used - keep back straight - bend using legs - when lifting load from floor level. Do not twist - reposition feet instead. Keep boiler as close as possible to body throughout lift to minimise strain on back. Ensure co-ordinated movements to ensure equal spread of weight of load. Always use assistance if required. Recommend wear suitable cut resistant gloves with good grip to protect against sharp edges and ensure good grip when handling appliance.

Positioning of Appliance for Final Installation - above worktop, foreseeable obstructions etc.

This appliance is deemed to be a one person lift when removed from the carton. Fit bracket securely onto wall before lifting appliance into position. Obtain firm grip on front and sides of appliance, lift upwards, onto worktop if practicable. Ensure stable balance achieved and lift upwards to position in place on bracket. If 2 persons positioning onto bracket obtain firm grip at front and sides/base of boiler. Ensure coordinated movements during 2 person lifts to ensure equal spread of weight of load. Ensure safe lifting techniques are used - keep back straight - bend using legs - when lifting load from floor level. Do not twist - reposition feet instead. Keep boiler as close as possible to body throughout lift to minimise strain on back. Avoid upper body/top heavy bending - do not lean forward/sideways. Always use assistance if required. Recommend wear suitable cut resistant gloves with good grip to protect against sharp edges and ensure good grip when handling appliance.

Positioning of Appliance for Final Installation - within compartment etc. restricting installation.

This appliance is deemed to be a one person lift when removed from the carton. Fit bracket securely onto wall before lifting appliance into position. Obtain firm grip on front and sides of appliance, lift upwards, onto worktop if practicable. Ensure stable balance achieved and lift upwards to drop into place onto bracket. If 2 persons positioning onto bracket obtain firm grip at front and sides/base of boiler. Ensure coordinated movements during 2 person lifts to ensure equal spread of weight of load. If 1 person positioning onto bracket recommend obtain firm grip supporting base of boiler. Ensure safe lifting techniques are used - keep back straight - bend using legs - when lifting load from floor level. Do not twist - reposition feet instead. Keep boiler as close as possible to body throughout lift to minimise strain on back. Always use assistance if required. Recommend wear suitable cut resistant gloves with good grip to protect against sharp edges and ensure good grip when handling appliance.

Positioning of Appliance for Final Installation - in roof space restricting installation.

This appliance is deemed to be a one person lift when removed from the carton. Obtain firm grip on front and sides of appliance, lift upwards, ensure stable balance achieved and lift upwards to drop into place onto bracket. If 2 persons positioning onto bracket obtain firm grip at front and sides/base of boiler. Ensure coordinated movements during 2 person lifts to ensure equal spread of weight of load. If 1 person positioning onto bracket recommend obtain firm grip supporting base of boiler. Ensure safe lifting techniques are used - keep back straight - bend using legs - when lifting load from floor level. Do not twist - reposition feet instead. Keep boiler as close as possible to body throughout lift to minimise strain on back. Always use assistance if required. Recommend wear suitable cut resistant gloves

with good grip to protect against sharp edges and ensure good grip when handling appliance. It is recommended a risk assessment of the roof space area be carried out before moving the appliance into the area to take into account access, stability of flooring, lighting and other factors, and appropriate measures taken.

4.2 Required minimum distances/assembly clearances

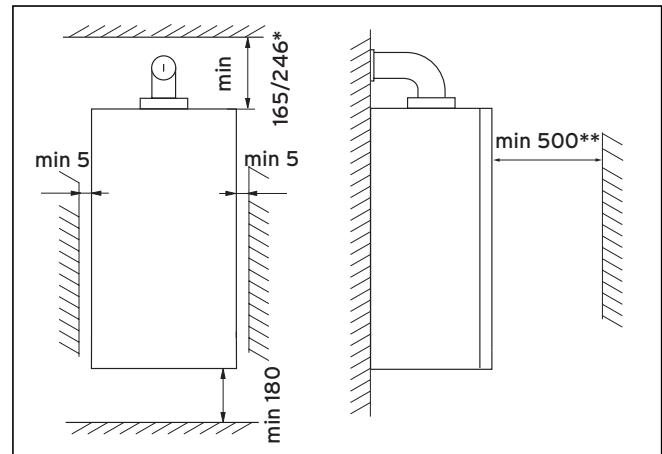

Fig. 4.1 Distances during installation (dimensions in mm)

The boiler should be mounted on a flat and vertical area of wall of sufficient area for the boiler plus the required clearances for installation and servicing (Fig. 4.1). These are shown on the installation template supplied with the boiler and are:

- 5 mm either side of the boiler
- 180 mm below the boiler
- 165 mm* above the boiler when utilising the 100 mm outside diameter flue
- 246 mm* above the boiler when utilising the 125 mm outside diameter flue
- 500 mm in front of the boiler to enable easy access for servicing (may be provided by an opening door)

Note

If the boiler is to be installed in a timber framed building, it should be fitted in accordance with „IGE/UP/7 Edition 2 Gas installations in timber framed and ligh steel framed buildings“.

4.2.1 Select position for boiler

Refer to section 3.4 'Installation site' for information regarding the appliance location. In general the boiler must be positioned such that:

- There is adequate space around the boiler for service and maintenance
- The boiler can be correctly flued, i.e. the flue terminal position is located in accordance with these instructions and the air/flue duct can be installed in accordance with the flue installation instructions supplied.
- All necessary pipework can be connected, including the pressure relief valve and condensate drain.

4 Boiler installation sequence

4.2.2 Unpack the boiler

To unpack the boiler, cut both plastic carton straps, open box and lift out the polystyrene top packing. Lift the cardboard box upwards.



Note

Care should be taken not to scratch the white surface of the boiler casing.

4.2.3 Using boiler template

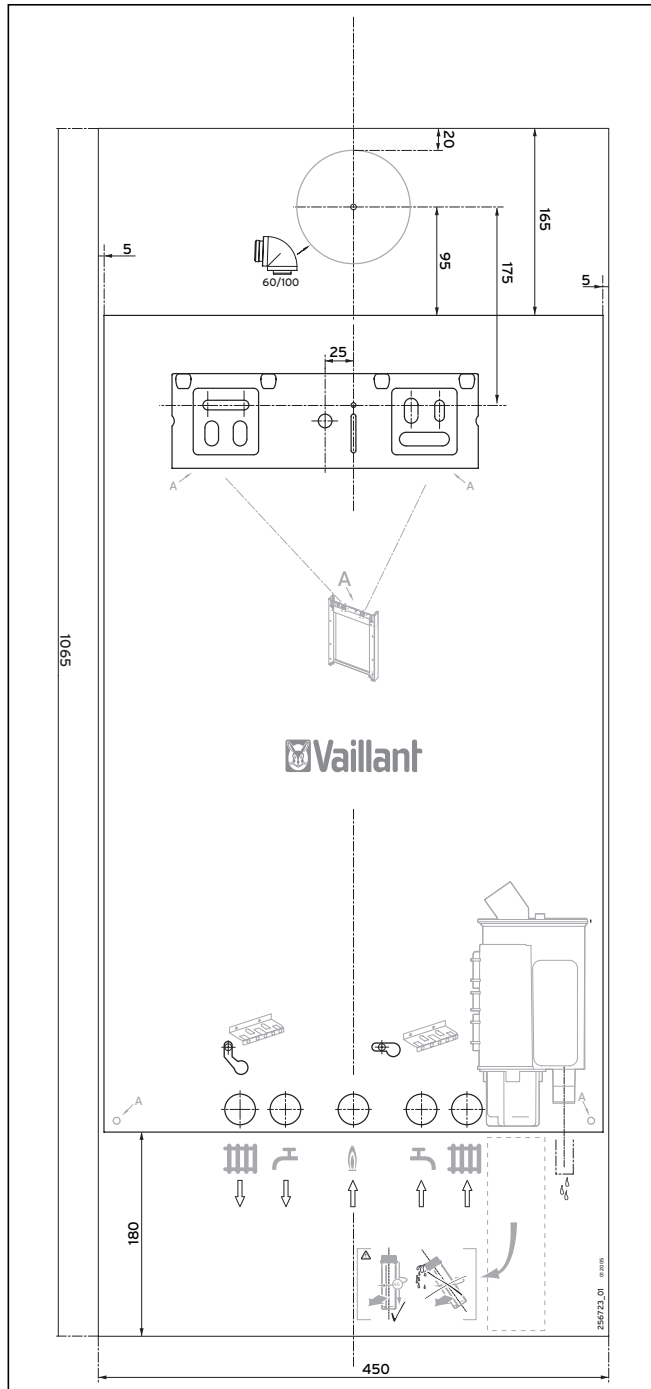

Fig. 4.2 Assembly template

- Fix the paper template to the wall ensure that the template is vertical.

The template shows:

- The position of the fixing holes for the boiler mounting bracket.
- The position of the connections.
- The position of the flue exit hole.

- Mark the position of the hanging bracket fixing holes.
- Drill 2 holes \varnothing 10 mm for the hanging bracket.



Note

Use alternative fixing holes where necessary.

4.3 Flue exit

- If using rear flue mark the position of the air/flue duct and its circumference.

Other flue options

Flue instructions for other flue systems such as vertical RSF flues, flues run to the side of the boiler and the use of additional bends etc. are detailed in the flue installation instructions provided with the boiler.

- Remove the template from the wall and plug the drilled holes using the wallplugs supplied.

4.4 Fitting the boiler hanging bracket

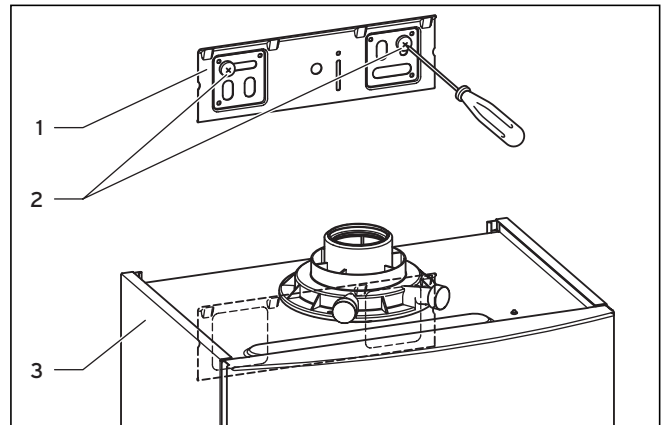

Fig. 4.3 Appliance with hanging bracket

- Fix the hanging bracket to the wall using the plugs and screws provided with the appliance.



Note

Use alternative fixing holes where necessary.



Note

If the boiler is to be fitted in a timber framed building ensure that the bracket is secured to a substantial part of the timber frame capable of taking the weight of the boiler.

4.5 Installing the flue system

- Install the flue system (refer to the separate air/flue duct installation instructions).

4.6 Fitting the boiler

- Lift the boiler (3) up to the wall so that it is slightly above the hanging bracket (1).

 **Note**
Lift the boiler from either side at the bottom edge

- Lower the boiler slowly onto the hanging bracket so that the cross member at the rear of the boiler fully engages onto the hanging bracket.

4.7 Removing the front case

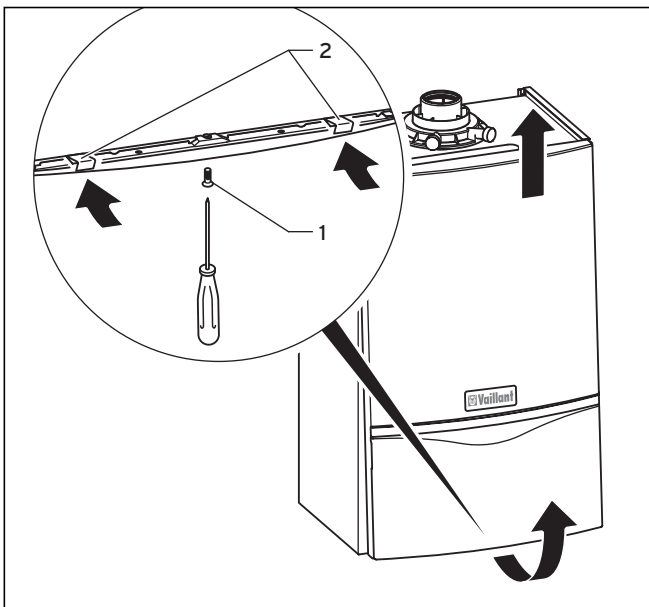



Fig. 4.4 Removing/fixing the front case

To remove the front section of the case, proceed as follows:

- Loosen the screw (1) on the bottom of the unit.
- Push in the two retaining clips (2) on the bottom of the appliance until the case is released.
- Grasp the front case by its bottom edge, pull it towards the front and remove it by lifting it off the unit.

4.8 General instructions for heating system

 **Caution!**
Thoroughly cleanse the heating system before connecting the appliance!
By doing that, residue such as welds, cinder, hemp, putty, rust, rough dust and similar substances are removed from the pipes. Otherwise such substances can be deposited in the appliance and cause damage.

- The appliance is fitted with an expansion vessel (10 l/0.75 bar).
- Before assembling the appliance check if this volume is adequate. If not, an extra expansion vessel must be installed, see section 3.10.5.

4.9 Gas connection

 **Note**
With the spacer frame (Art. No 308 650), the pipes can be fitted vertically upwards behind the appliance. The distance of the appliance from the wall thus increases by 65 mm.

 **Danger!**
The gas connection may only be made by a competent person approved at the time by the Health and Safety Executive and in accordance with the gas safety (installation and use) regulations 1998.
The legal directives and the local regulations for gas supply companies must be observed.

 **Caution!**
Ensure a stress-relief assembly of the gas pipes to avoid leakages!

 **Caution!**
The gas regulating block may be tested for leakage only with a maximum pressure of 150 mbar!
Higher testing pressures can damage the gas fitting.

 **Caution!**
When making final connection to the boiler, if using soldered fittings, extra care should be taken to avoid damage to isolation valves through heat transfer.

4 Boiler installation sequence

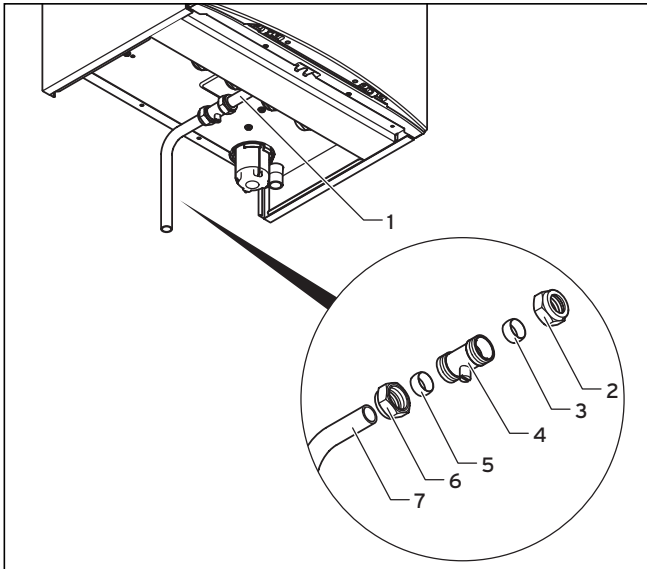

Fig. 4.5 Fitting the gas connection (example ecoTEC plus combination boiler)

- Fit the union nut (2) and the compression olive (3) to the gas connection pipe (1) of the boiler.
- Fit the union nut (6) and the compression olive (5) to the pre-formed tail provided with ecoTEC plus appliances (7).
- Fully insert the service valve (4) onto the gas connection pipe and the pre-formed tail into the service valve. Tighten both union nuts of the service valve.
- The diameter of the pipework (7) is 15 mm (22 mm for 37kW models). Connect a gas supply pipe of not less than 15 mm diameter to the copper tail.

 **Note**

Ensure the gas supply pipework is adequately sized so that a 20 mbar gas pressure is available at the boiler inlet at full flow rate.

- Tighten all connections.
- Check the gas connection with leak indicator spray for leakage.

4.10 Cold water mains inlet and hot water outlet (ecoTEC combination boilers only)

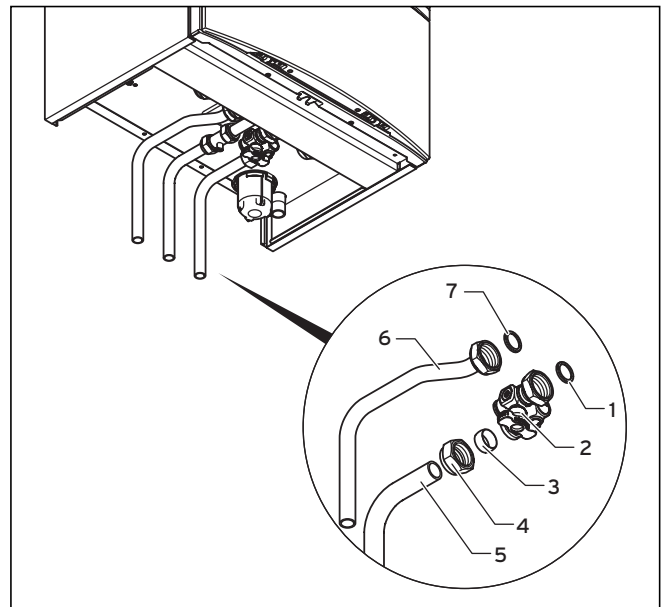

Fig. 4.6 Installing the hot and cold water connection (ecoTEC plus combination boiler)

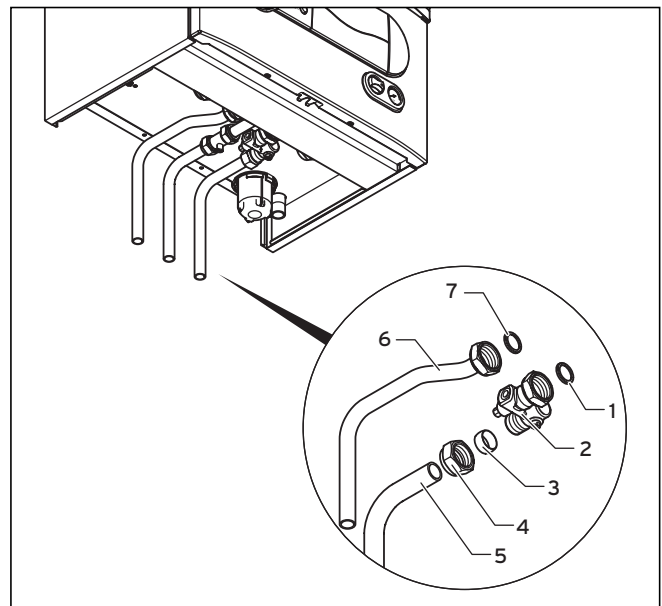

Fig. 4.7 Installing the hot and cold water connection (ecoTEC pro combination boiler)



Caution!

When making final connection to the boiler, if using soldered fittings, extra care should be taken to avoid damage to isolation valves through heat transfer.

Note
Flush all foreign matter from the mains supply before connecting to the boiler.

- Insert the seal (1) and connect the service valve (2) to the appliance cold water connection.
- Fit the union nut (4) and the compression olive (3) to the pre-formed tail provided with ecoTEC plus appliances (5). The diameter of the pipe is 15 mm.
- Fully insert the pre-formed tail into the service valve. Tighten the union nuts.
- Insert the seal (7) and connect in the pipe (6) to the appliance hot water connection. The diameter of the pipe is 15 mm.
- Mount the handle for the filling loop with a counter-sunk screw to the service valve (2).

4.11 Condensate drain pipe

The ecoTEC plus appliances are fitted with a siphonic trap (The filling height is 145 mm). The siphon collects the accumulated condensate in a container of approx. 200 ml capacity and directs the entire content into the drain pipe. The risk of the condensate drain pipe freezing is thus minimised.

The ecoTEC pro appliances are equipped with a normal condensing water trap where the condensate is constantly emptied into the drain pipe.

- Connect the boiler condensate drain (1) to a condensate discharge pipe (2) which should be minimum of 19 mm internal diameter (22 mm external diameter for any pipework installed external to the property) and be made of an acid resistant material (e.g. plastic overflow pipe).

Note
If a boiler does not include a siphon then any external condensate drainage pipe shall be increased to a minimum diameter of 32 mm nominal diameter to reduce the risk of freezing. In exposed locations, the condensate drainage pipework shall be protected with waterproof pipe insulation. Additionally when a boiler is installed in an unheated location such as a garage all condensate drainage pipes should be considered as external.

Note
The discharge pipe from the boiler condensate drain must have a continuous fall (45 mm per meter) and preferably be installed and terminated within the building to prevent possible freezing.

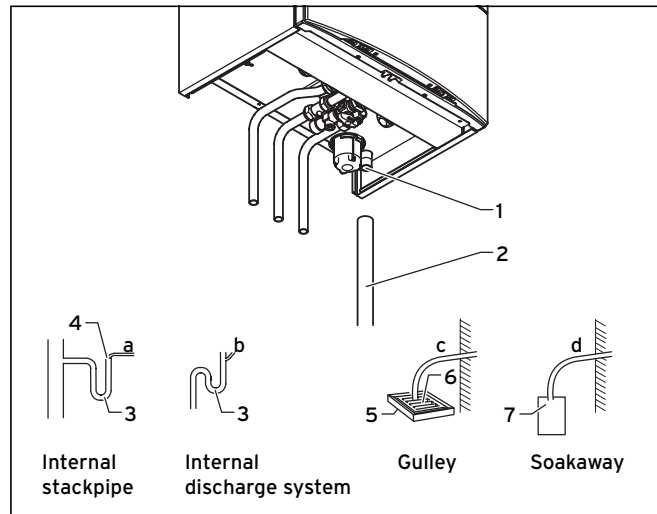

Fig. 4.8 Installing the condensate drain pipe (picture shows ecoTEC plus combination boiler)

The condensate discharge pipe must terminate in a suitable position, e.g.:

- preferably the discharge pipe should run and terminate internally to the house soil and vent stack (at least 450 mm above the invert of the stack). A trap giving a water seal of at least 75 mm (3) (built into the boiler) should be incorporated into the pipe run, and there must be an air break (4) in the discharge pipe upstream of the trap. The connection to the stack should not be made in a way that could cause cross flow into any other branch pipe, or from that branch pipe into the condensate drainpipe. This can be achieved by maintaining an offset between branch pipes of at least 110 mm on a 100 mm diameter stack and 250 mm on a 150 mm diameter stack.
- connecting into the internal discharge branch (e.g. sink waste or washing machine) with an external termination, the condensate discharge pipe should have a minimum diameter of 22 mm with no length restriction and should incorporate a trap with a 75 mm (3) (built into the boiler) seal. The connection should preferably be made down stream of the sink waste trap. If the connection is only possible upstream, then an air break is needed between the two traps. This is normally provided by the sink waste.
- terminating in a gully (5) below grid level (6) and above the water level. The external pipe length should be kept as short as possible to minimise the risk of freezing and should not be more than 3m.
- at a condensate absorption point (soakaway) (7). The external pipe length should not be more than 3m.

Refer to 'BS 6798 Specification for installation of gasfired boilers of rated input not exceeding 70 kW net' for further information. Before operating the boiler the condensate trap (1) must be filled with water as described in relevant section.

4 Boiler installation sequence

4.12 Heating connection



Caution!

When making final connection to the boiler, if using soldered fittings, extra care should be taken to avoid damage to isolation valves through heat transfer.

4.12.1 Heating flow and return connection



Note

Before connecting the heating circuit to the boiler, all pipework and radiators must be thoroughly flushed to remove any installation debris.

ecoTEC plus combination boiler

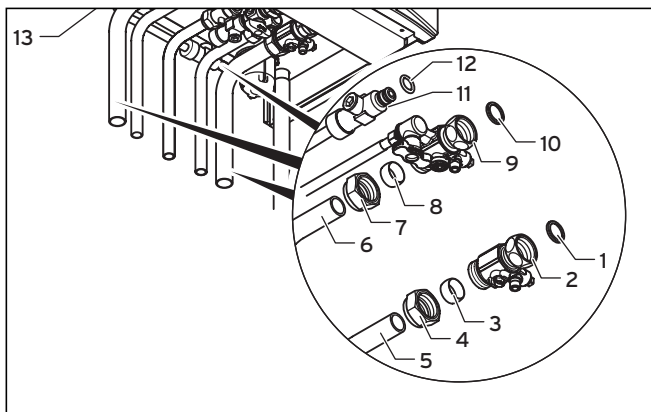

Fig. 4.9 Installing the heating flow and return connection for ecoTEC plus combination boiler

- Insert the seal (1) and fit the service valve (2) to the return connection of the appliance.
- Insert the seal (10) and fit the service valve (9) to the flow connection of the appliance.
- Install the O-ring seal (12) on the return valve (11).



Note

Lay the filling loop hose (13) above the pipework elbows.

- Fit the union nuts (4) and (7) as well as the compression olives (3) and (8) to the pre-bended 22 mm copper tails (5) and (6).
- Fully insert pipes (5) and (6) into the service valves. Tighten the union nuts in this position.
- Fit the handle for the filling loop with a countersunk screw to the service valve (9).

ecoTEC pro combination boiler

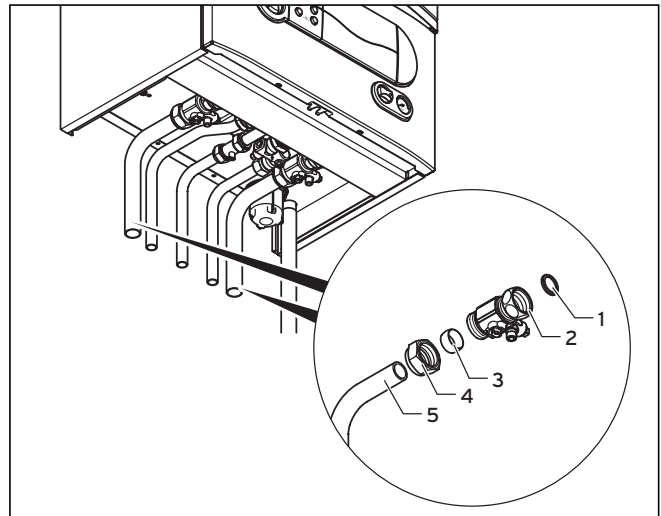

Fig. 4.10 Heating flow and return connection for ecoTEC pro combination boiler

- Insert a seal (1) and fit the service valves (2) to the flow and return connection of the appliance.
- Fit a union nut (4) and a compression olive (3) to the 22 mm pre-bended copper tail (5).
- Fully insert pipe (5) into the service valve. Tighten the union nuts in this position.

ecoTEC plus system boiler

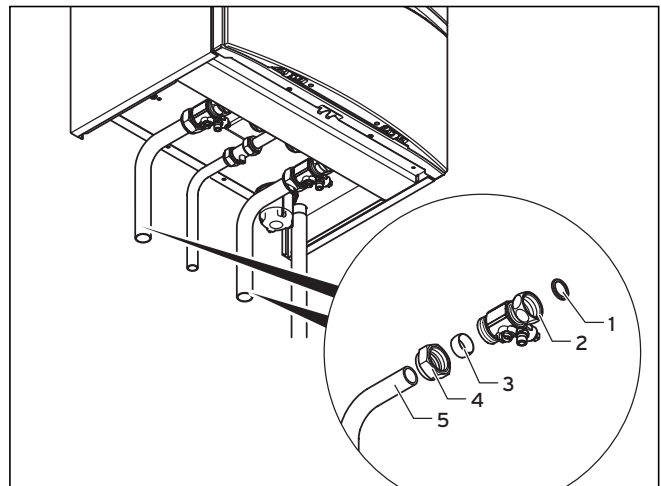

Fig. 4.11 Heating-side flow and return connection for ecoTEC plus system boiler

- Insert a seal (1) and fit the service valves (2) to the flow and return connection of the appliance.
- Fit a union nut (4) and a compression olive (3) to the 22 mm pre-bended copper tail (5).
- Fully insert pipe (5) into the service valve. Tighten the union nuts in this position.



Caution!

To ensure fumes do not escape through the syphon of the boiler the trap must be filled with water before the boiler is turned on. Therefore the discharge pipework should be installed so as not to interfere with the removal and refitting of the condensate trap, we recommend the outlet pressure release valve pipe supplied is not shortened. You must leave a bottom clearance of at least 180mm below the condensate trap for removal and refitting.

4.12.2 Pressure Relief Valve

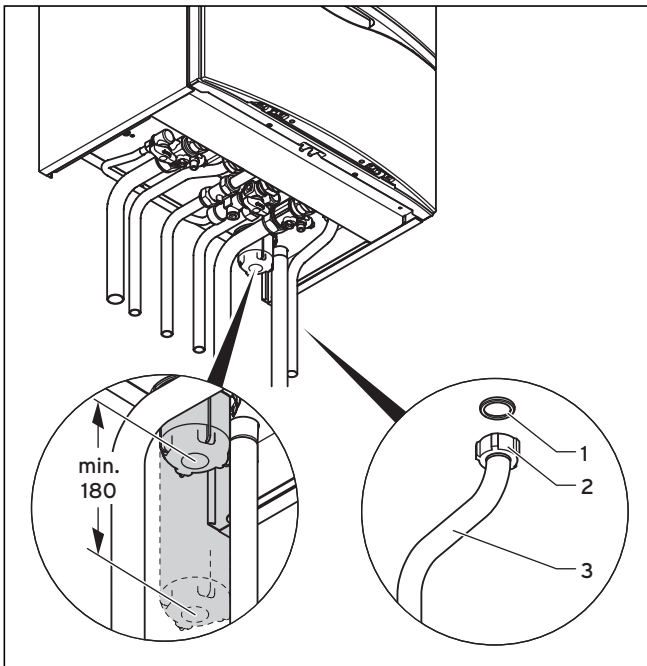

Fig. 4.12 Installing the drain pipe on the pressure release valve of the heating system (picture shows ecoTEC plus combination boiler)

The pressure release valve for the heating system is integrated in the appliance.

- Position the seal (1) and screw the drain pipe (2) on to the pressure release valve.

The discharge pipework should be as short as possible and installed with a continuous fall away from the boiler. The pipe should terminate in a position which ensures that any discharge of water or steam from the valve cannot create a hazard to persons in or around the premises, or cause damage to any electrical components or external wiring, and the point of discharge should be clearly visible.

4.13 Connecting the flue system to the boiler

- Refer to separate air/flue duct installation instructions included with the boiler.

4.14 Electrical connection

4.14.1 General requirements



Danger!

Electrocution caused by touching live parts can be fatal.

Before working on the appliance, turn off the power supply and secure against restart.

All electrical work shall be carried out by a competent person and shall comply with BS7671 (IEE Regulations). In the Republic of Ireland, reference should be made to the current edition of the ETCI (Electro-Technical Council for Ireland) rules. The boiler is supplied for connection to 230 V, ~ 50 Hz supply fused at 3 A rating. Connection to the mains supply shall be made via a fused 3 pin plug to an unswitched shuttered socket, both complying with the requirements of BS1363. (Alternatively, connection may be made via a 3 A fused double pole isolator having a contact separation of at least 3 mm in all poles and supplying the boiler and controls only). The point of connection to the mains supply must allow complete electrical isolation of the boiler and its ancillary controls. It should be readily accessible and adjacent to the boiler. A 3 core flexible cord according to BS6500 Tables 6, 8 or 16 (3 x 0.75 to 3 x 1.5 mm²) should be used.



Danger!

This appliance must be earthed.



Danger!

Mains connection terminals L and N remain live even when the boiler on/off control is switched off.



Note

Do not connect any power voltage to the connections 7-8-9 or BUS (+,-).



Note

Ensure that all cords pass through the cable clamps in the rear of the control box and are securely fixed. Ensure that the power supply is connected such that the current carrying conductors become taut before the earth conductor should the supply cord slip from the cable clamp.

4 Boiler installation sequence

4.14.2 Connection to the main supply

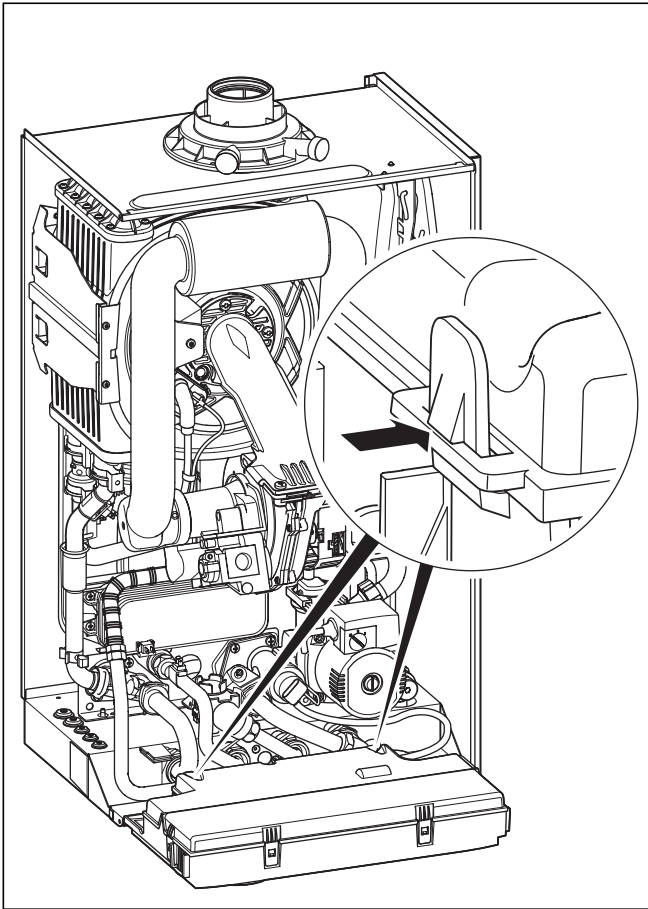

Fig. 4.13 Opening the electronics box

- Remove the front case and lower the control panel.
- Unclip the bottom of the terminal box cover and hinge back to reveal the connection plugs.
- Feed the power supply flex into the appliance and the control panel through the cable clamps provided and tighten.

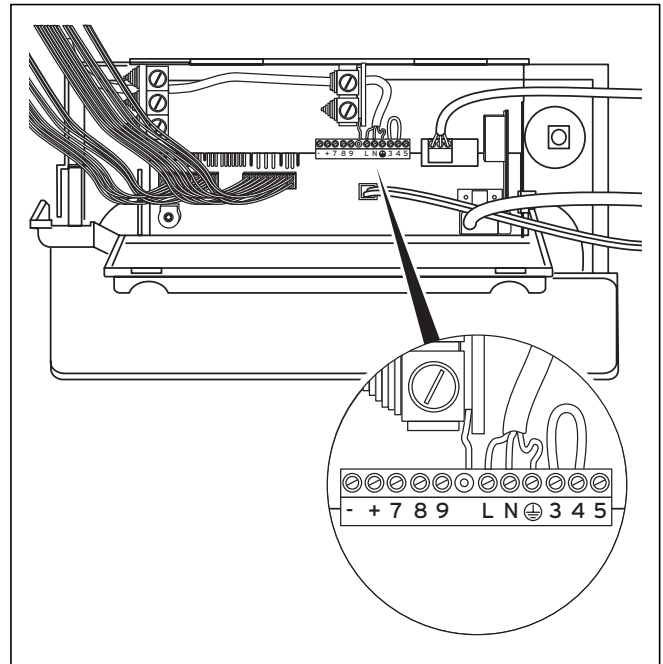

Fig. 4.14 Wiring system

- Connect the flex to the L, N and earth plug to the terminal block.

Green/yellow (earth) wire - boiler terminal Earth sign

Blue (neutral) wire - boiler terminal N

Brown (live) wire - boiler terminal L

 **Note**

Do not connect any power voltage to the connections 7-8-9 or BUS (+,-).

 **Note**

Ensure that the wires are securely fixed in the terminal block.

- Refit the terminal box cover by pushing into place until it clips back into position.
- Raise the control panel.

4.14.3 Electric board layout

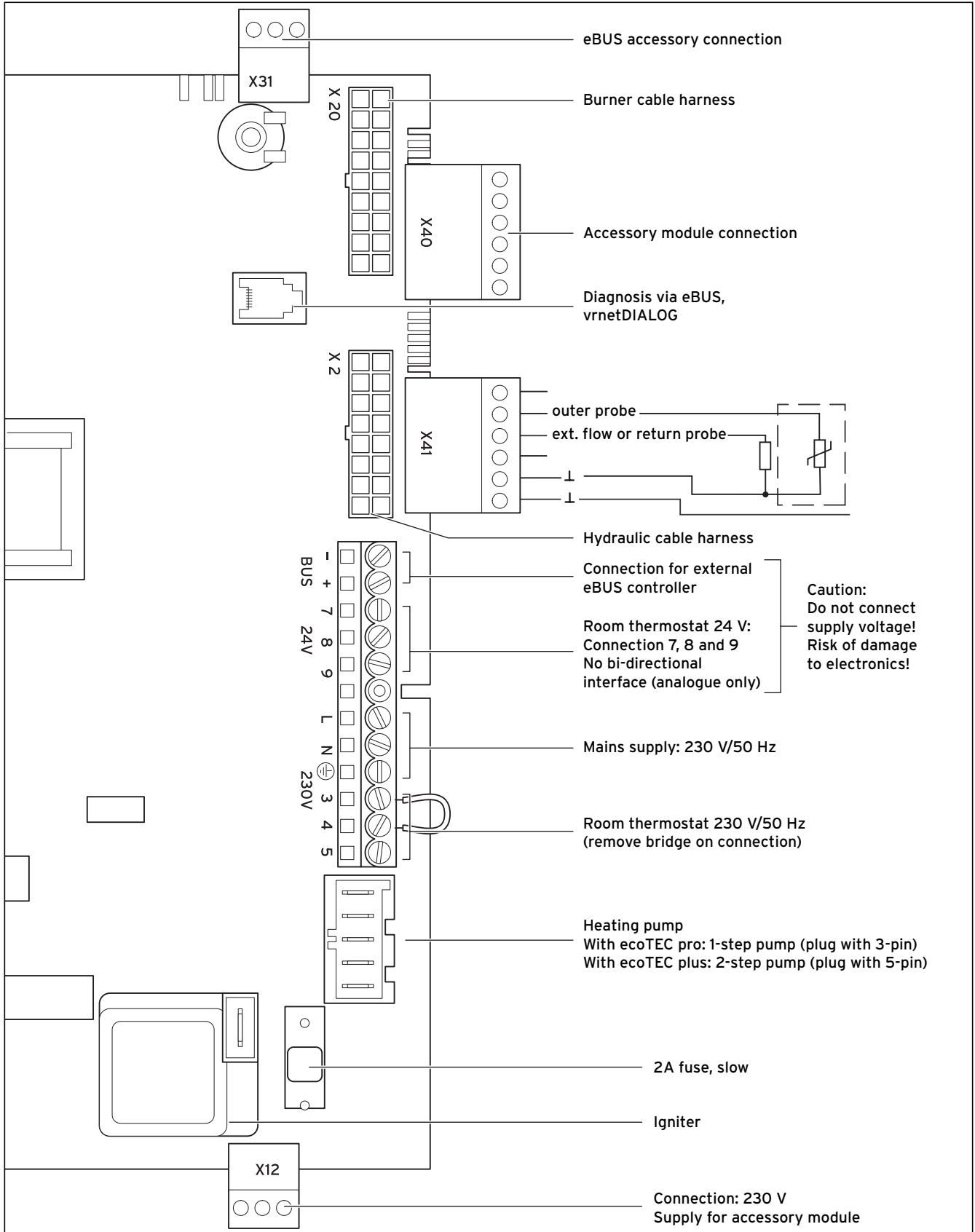

Fig. 4.15 Connection wiring ecoTEC

4 Boiler installation sequence

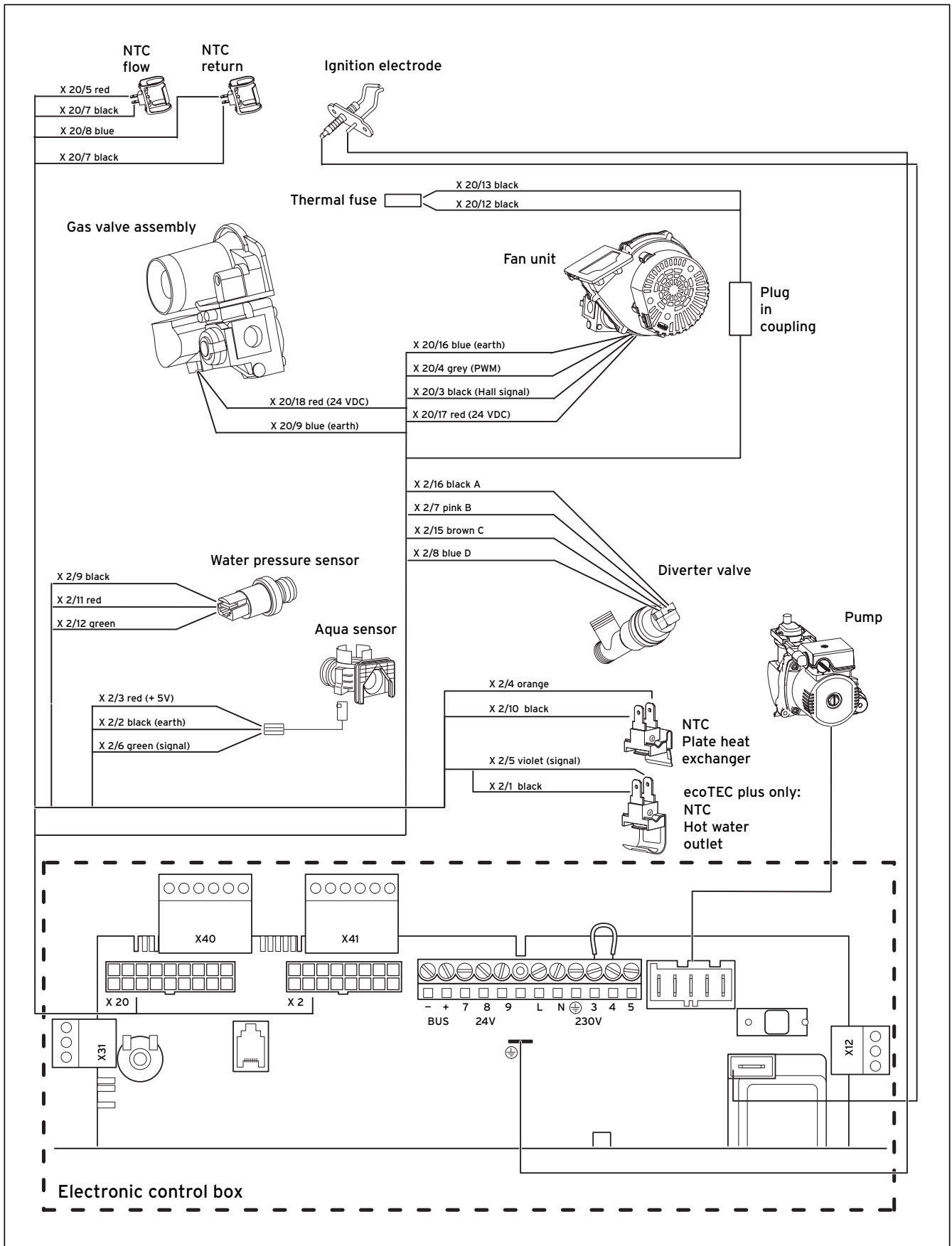

Fig. 4.16 Connection wiring ecoTEC combination boiler

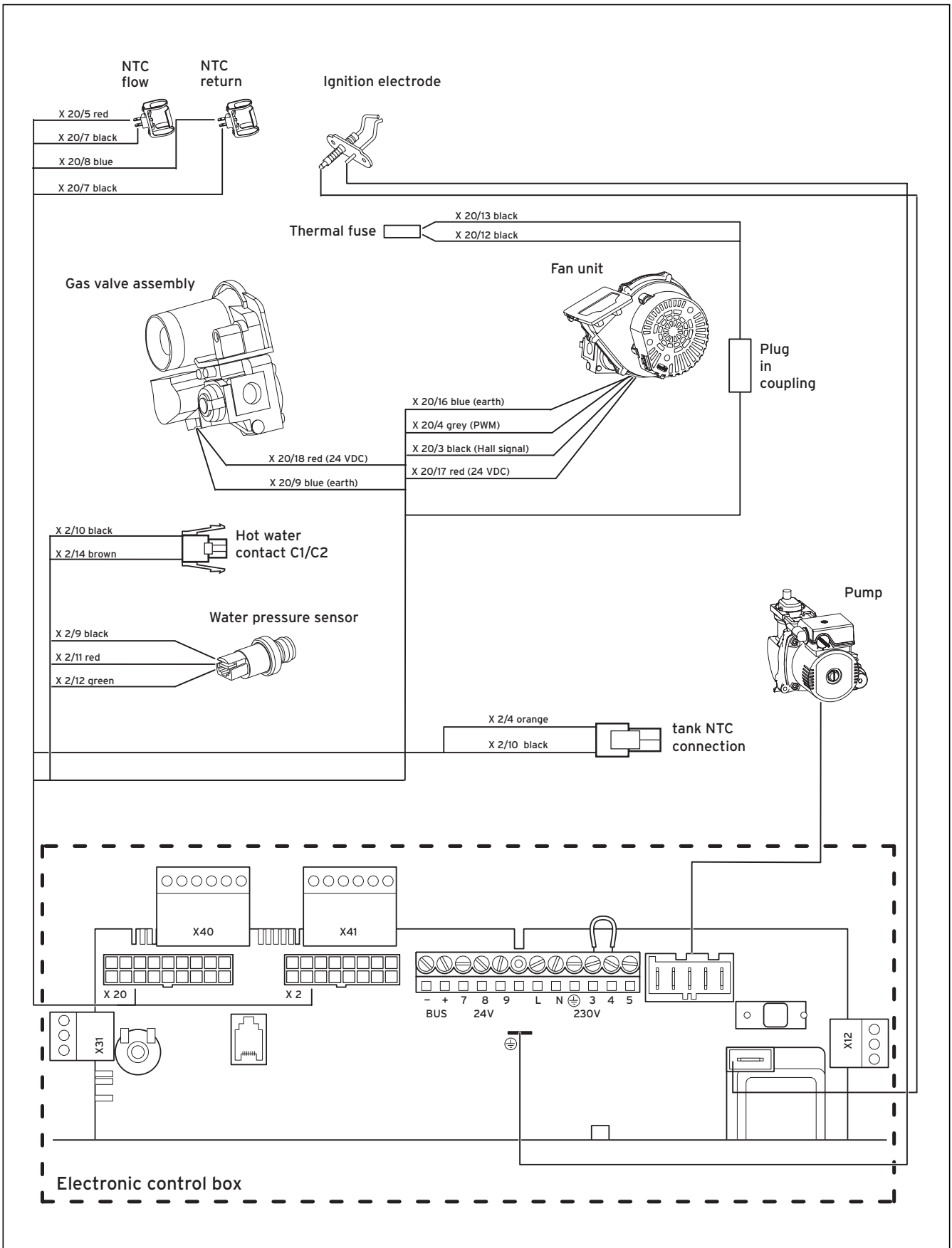

Fig. 4.17 Connection wiring ecoTEC system boiler

4 Boiler installation sequence

4.15 Controls

4.15.1 Vaillant controls and accessories

Controller	Item no.	Connection
VRC 400 (1-circuit controller, weather-controlled)	0020010843	Installation in electronics box (plug-and-play)
VRT 360 (room temperature controller)	0020010842	Wall-mounted, 2-wire bus
Available from 10-01-2006 VRT 360f (room temperature controller)	0020018258	Wireless controller, receiver wall-mounted
VRT 230 (room temperature controller)	0020010841	Wall-mounted, 3-wire connection to terminals 3-4-5
timeSWITCH 140 (timer)	306760	Installation in electronics box (plug-and-play)
timeSWITCH 130 (timer)	306759	Installation in electronics box (plug-and-play)
VRT 30 (room thermostat)	300637	Wall-mounted, 3-wire connection to terminals 3-4-5
VRT 50 (room thermostat)	0020018265	Wall-mounted, 2-wire bus
Telecommunication	Item no.	Connection
vrnetDIALOG 830 (Int)	0020003988	GSM/GPRS, installation in electronics box (plug-and-play)
vrnetDIALOG 860/2 (Int)	0020003984	Wall-mounted, GSM/GPRS, up to 16 appliances
Accessories	Item no.	Connection
VR 65 control centre for UK cylinder installation (eBUS)	307215	System solution for UK cylinder connection
vrDIALOG 810/2	0020023370	Diagnostic software

Table 4.1 Vaillant controls and accessories

4.15.2 External electrical controls

The boiler terminals 3, 4 and 5 are for connecting external electrical controls such as a time switch and/or room thermostat. Terminals 3 and 4 are linked together when the boiler is supplied. If external controls are used, this link must be removed, and the controls connected across terminals 3 and 4. Terminal 5 is an additional neutral connection for external neutrals such as from the anticipator of a room thermostat.

4.15.3 Connection details for external time switches and boiler terminal strip

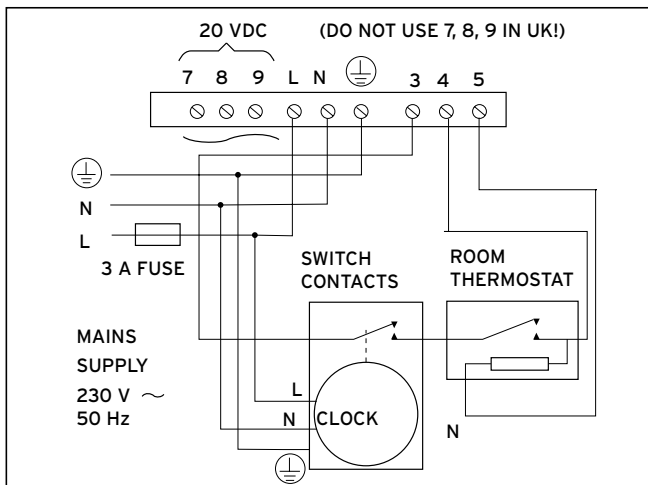

Fig. 4.18 Connection details for time switches

If a room thermostat is to be connected in addition to a time switch the wire between the time switch "ON" terminal and boiler terminal 4 should be broken by the contacts of the room thermostat (see schematic layout, Fig. 4.18).

4.15.4 Vaillant optional plug in timer accessories

Refer to the instructions supplied with the optional accessories for connection details. Upon completion of all electrical connections refit the terminal box cover by pushing into place. The cover is secured by two locking clips.

4.15.5 Connection details using the VR 65 Control Center

The VR 65 Control Center is an eBUS system component. In a storage unit installation, it is responsible for the communication between the storage unit, the ecoTEC plus system boilers and external 2- or 3-way valves. Connect the VR 65 Control Center as described in the enclosed manual.

4.16 Thermostatic radiator valves

The boiler has a built in automatic by-pass valve making it ideal for use in systems with thermostatic radiator valves (no separate system by-pass is required). For optimum fuel economy where TRV's are used they must be used in conjunction with a boiler control interlock. A programmable room thermostat or separate timer and room thermostat will ensure complete boiler shut down when the heating demand is satisfied. (The radiator in the room containing the room thermostat should not be fitted with a TRV).

4.17 Frost protection

The boiler has an integral frost thermostat which is designed for protection of the boiler. To protect remote or exposed parts of the heating system or property additional frost protection measures must be taken such as the installation of an external frost thermostat. This frost thermostat should be connected across the boiler terminals 3 and 4, in parallel with any external heating controls.



Note

External frost protection cannot be used when plug in timers are utilised.

4.18 Circulating pump

The boiler incorporates a built in circulating pump that is fully prewired (no additional wiring is necessary). The pump incorporates an automatic overrun period after the boiler switches off.

4.19 Anticycling 'economiser' control

The boiler incorporates a built in anticycling control to ensure that energy wasteful short cycling of the boiler cannot occur. This control prevents the boiler from reigniting for a preset period after central heating operation (the hot water operation is unaffected by this control and hot water can be drawn at any time).



Note

To temporarily override the anticycling control turn the main boiler on/off switch to the off position "O" and then back to the on position "I" after a few seconds.

4.20 Automatic pump spin control (APS)

The boiler incorporates a built in control which will spin the built in circulating pump and operate the diverter valve (ecoTEC combination boilers only) once in a 23 hour period. This control helps to prevent seizure when the boiler is not operated for a period of time. This control is not active when the power supply to the appliance is turned off.

5 Commissioning Part I

5.1 Preliminary electrical checks

Check the electrical installation by carrying out short circuit, earth continuity and resistance to earth tests and a check for correct polarity.

5.2 Gas supply

The complete gas installation including the gas meter must be inspected, checked for leaks and purged in accordance with BS6891. In IE the current edition of IS 813. The gas supply to the boiler can be purged by slackening the gas service valve beneath the boiler. Ensure that there is adequate ventilation, extinguish all naked flames and do not smoke whilst purging. After purging, the gas service valve connection must be retightened and checked for leaks (the boiler itself does not require purging as this will be done by the automatic burner sequence control).

5.3 Cold water supply (ecoTEC combination boilers only)

Open all domestic hot water taps supplied by the boiler, turn on the mains water supply to the boiler and open the mains water isolating valve below the boiler. Water will now flow through the boiler to the hot taps. Starting with the lowest tap supplied, turn the hot taps off one at a time until the hot water pipework is purged of air. Check all hot and cold water pipework for leaks.

5.4 Filling and bleeding the heating system



Note

The P.6 test program is for filling the heating system: The diverter valve (combination boilers only) moves to the centre position, the pump does not run and the appliance does not go into heating mode. Use the test program as described in Section 8.2.

The P.0 test program is for bleeding the hot water circuit (as well as the DHW circuit on combination boilers): The appliance does not go into heating mode; the pump runs intermittently and bleeds the two circuits in succession. Use the test program as described in Section 8.2.



Note

The ecoTEC appliances come with a manometer and a digital pressure indicator. The manometer allows you to quickly check whether the filling pressure is in target range or not even when the appliance is turned off. If the appliance is in operation, you can display the exact pressure by pressing the "-" (2).

For the heating system to operate properly, the indicator on the manometer (1) must be in the dark grey area when the system is cold.

This corresponds to a filling pressure between 1.0 and 2.0 bar. If the pointer is in the light grey area, refill water.

If the heating system extends over several storeys, the system may require a higher filling pressure.

5.4.1 Checking the filling pressure of the heating system

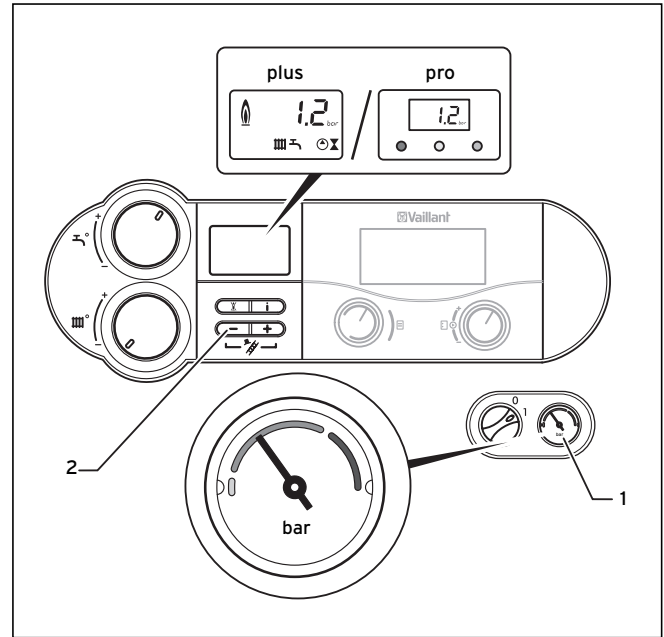

Fig. 5.1 Checking the filling pressure of the heating system

5.4.2 ecoTEC plus combination boiler filling loop

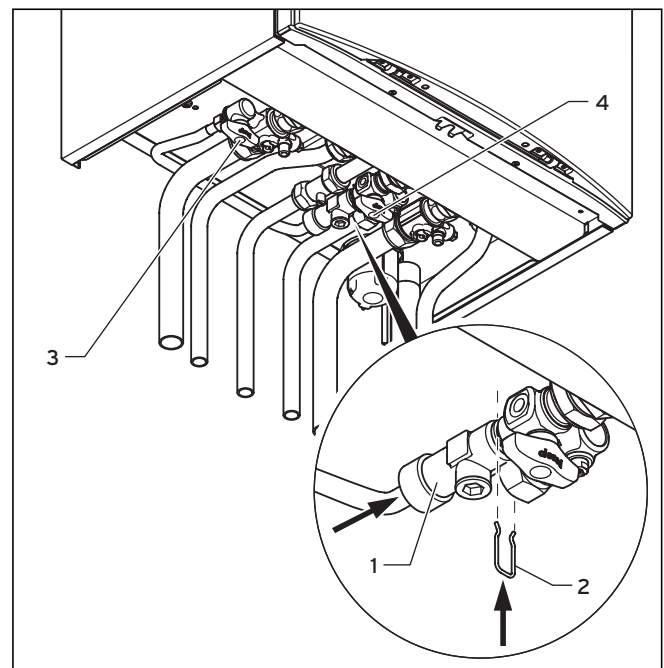



Fig. 5.2 Filling device ecoTEC plus combination boiler

The ecoTEC plus combination boiler will be delivered with a filling loop.

- Insert the double check valve (1) of the filling pipe at the cold water shutoff valve and secure the double check valve with the spring clip (2).
- To fill, first open the stop valve (3).
- Open the stop valve (4), so that water flows into the heating system. Fill the heating system as described in Section 5.4.4.
- Close both stop valves after filling and detach the filling device by pulling the double check valve from the cold water stop valve.

 **Note**
Both stop valves must be closed while operating the heating system and the filling pipe must be again detached at the double check valve.

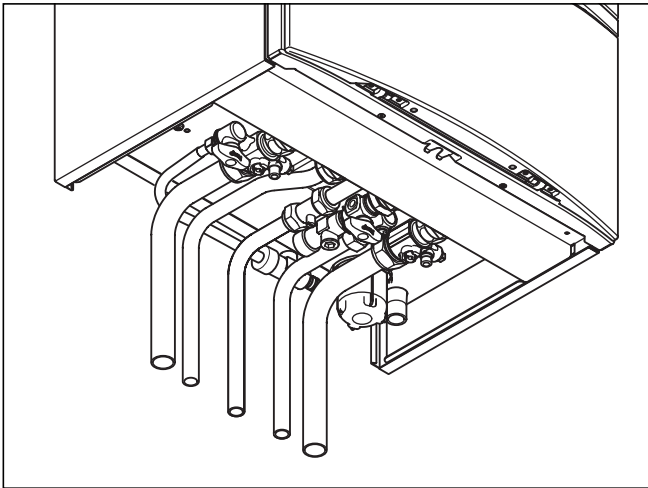



Fig. 5.3 Double check valve detached while heating

5.4.3 Filling the heating system in ecoTEC pro combination boilers and ecoTEC plus system boilers

The ecoTEC pro combination boilers and the ecoTEC plus system boilers do not come with a filling device. In these appliances, water is filled in the heating system through a filling pipe provided onsite.

- Join a hose between a cold water dispensing valve and the filling pipe of the heating system.
- To fill, first open the cold water dispensing valve.
- Open the stop valve on the filling pipe, so that water flows into the heating system. Fill the heating system as described in Section 5.4.4.
- After filling, close the stop valve on the filling pipe and the cold water dispensing valve and remove the filling hose.

5.4.4 Filling the heating system for the first time

 **Note**
As long as there is insufficient water pressure in the heating system, the display indicator changes between the error message F.22 and the actual pressure indicator when the appliance is on.

Fill the heating system as follows:

- Open all heating element thermostat valves.
- Check if both stop valves on the heater are open.
- Only in ecoTEC plus combination boilers: Connect the filling pipe as described in Section 5.4.2.
- Only in ecoTEC plus system boilers and in ecoTEC pro combination boilers: As described in Section 5.4.3 join a hose between the cold water dispensing valve and the filling pipe of the heating system.
- Open the cold water dispensing valve.
- Slowly open the filling valve and let the water flow into the heating system. Bleed the lowest radiator until the water flows out at the bleed valve without bubbles.
- Bleed all other radiators until the heating system is completely filled with water, all bleed valves have been shut and the manometer pointer is in the centre of the dark grey area. Bleed the heating pump by loosening the central screw. Close the filling valve and the cold water dispensing valve.
- Loosen the cap of the pump A.A.V. (automatic air vent) (the appliance is ventilated independently by the pump A.A.V. during continuous operation).
- Check all connections and the entire system for leaks.

5.5 Initial system flush ("cold")

 **Note**
The complete heating system must be flushed out at least twice: once cold, and once hot as instructed below.

- Check if all radiator thermostatic valves and both service valves on the boiler are open.
- Connect a hose to the drain valve located at the lowest position of the heating system.
- Open the 1/2" BSP drain taps and all vent valves on the heating elements and allow the water to flow out of the heating system and the boiler quickly and completely to remove all installation residue from the heating system before commissioning the boiler.
- Close the 1/2" BSP drain taps.
- Fill the heating system again with water as described in Section 5.4.4.
- Check that the pressure relief valve of the heating system is working by turning the handle on the valve.
- Check the pressure in the heating system and fill water if needed.
- Close the filling valve and the cold water dispensing valve.

5.6 Filling the condensate siphon

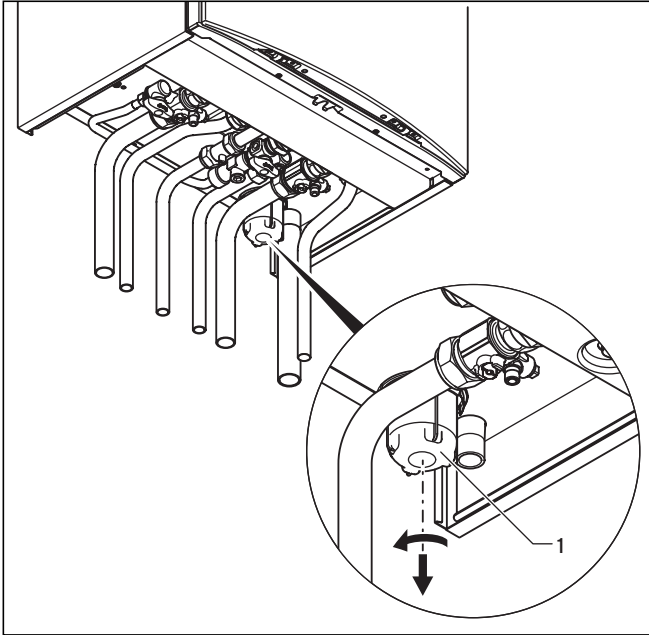

Fig. 5.4 Filling the condensate siphon

Danger!
 Note that if the boiler is run with an empty condensate trap there is a danger that fumes might escape into the room and cause poisoning. For this reason, it is important to ensure that the trap is topped up each time the unit is cleaned.

- Remove the lower part (1) of the condensate siphon by turning the bayonet catch in anticlockwise direction.
- Fill the lower part with water until about 10 mm below the upper edge.
- Refit the lower part of the condensate siphon.

5.7 Adjusting the pumping capacity

Only in ecoTEC plus boilers:

The capacity of the two-stage pump can be adjusted to the requirements of the heating system. If needed, change the setting of the operating mode dependent pump speed under the diagnostic number "d.19" (see section 8.1.2).

5.8 Adjusting the by-pass

The appliances have an adjustable by-pass valve. The pressure can be adjusted between 170 and 350 mbar. Approx. 250 mbar is preset (mid-position). The pressure changes by approx. 10 mbar each time the adjusting screw is rotated. By turning right, the pressure increases and turning left decreases it.

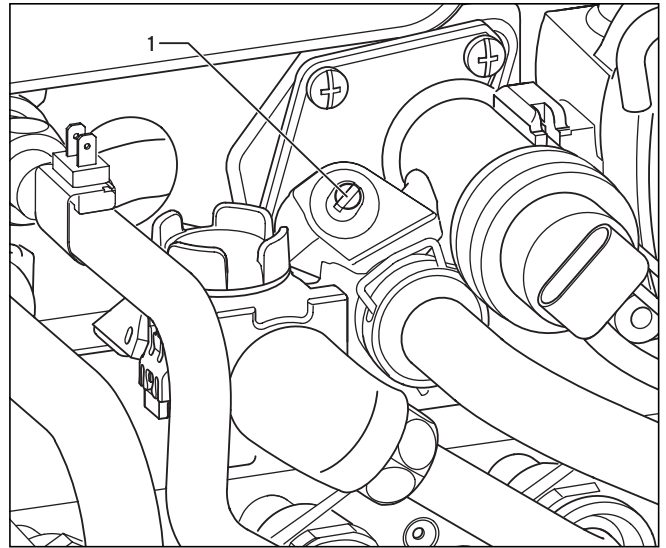

Fig. 5.5 Adjusting the by-pass valve (in combination boilers)

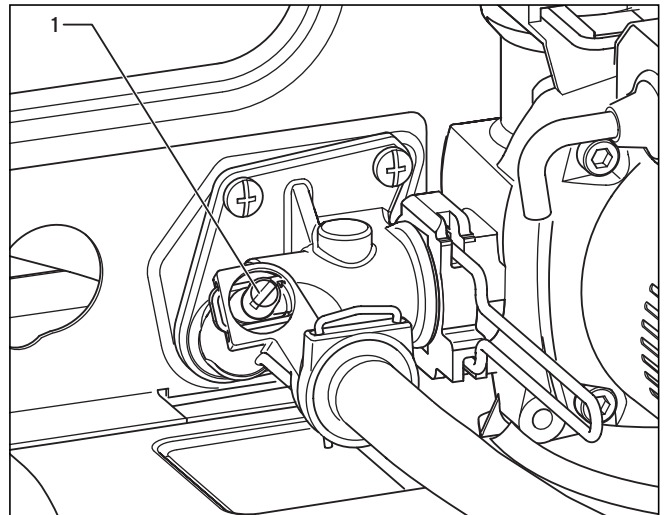

Fig. 5.6 Adjusting the by-pass valve (in system boilers)

- Regulating the by-pass on the adjusting screw (1).

5.9 Checking the gas setting

Caution!
Malfunctions or reduction in working life of the boiler!
 If the boiler version does not correspond to the local gas family, there will be malfunctions or you have to change components of the boiler ahead of schedule, e. g. do not use a LPG boiler on natural gas.

- Before starting up the boiler compare the details of the type of gas specified on the identification plate with the type of gas supplied at the installation site.

If the boiler version corresponds to the local gas family:

- Proceed as described below.

If the boiler version does not correspond to the local gas family:

- Perform the gas conversion in accordance with the gas conversion kit 0020010641.
- Adjust the gas setting as described below (see sections 5.9.1 to 5.9.3).

The combustion of this boiler has been checked, adjusted and preset at the factory for operation on the type of gas defined on the identification plate. No measurement of the combustion is necessary to set up the boiler.

- Do not adjust the multifunctional automatic gas valve.
- Ensure
 - that the boiler has been installed in accordance with these instructions,
 - the integrity of the flue system and the flue seals, as described in the flue installation instructions enclosed with this boiler, and as described below,
 - a visual check is carried out on the boiler combustion circuit and the relevant seals,
 - that any defects have been corrected at this stage.

To further validate the integrity of the flue system and confirm correct operation of the boiler it is possible to conduct flue gas and air measurements on this boiler - for details see section 5.9.1.

Proceed to put the boiler into operation as follows:

- Check the maximum gas flow rate as detailed in section 5.9.2.
- Check the gas inlet working pressure as detailed in section 5.9.3.
- Note that you must re-measure the gas flow rate or the gas inlet working pressure, if changes were required to correct any issues found.

5.9.1 Checking for tightness of the flue gas installation and flue gas recirculation

- Check the integrity off the flue gas installation according to TB 200.
- Should the flue gas installation be longer than 2 m we strongly recommend to check the system for flue gas recirculation as described below.

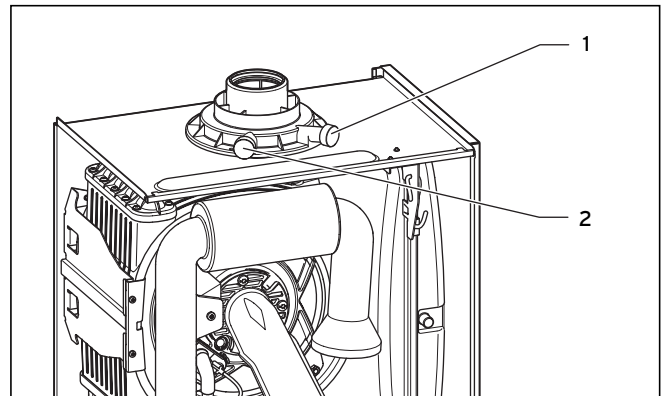

Fig. 5.7 Flue gas and air measure points

Legend:

- 1 Flue gas measure point
- 2 Air measure point

- For checking the system for recirculation use the air measure point (2).
- Use the flue gas analyser.
- If you detect any CO or CO₂ in the fresh air, search for the flue gas leakage or recirculation.
- Correct the defects.
- Check again as described before, if there is any CO or CO₂ in the fresh air.
- If you cannot correct the defects you must not start up the boiler.

5.9.2 Checking the gas flow rate

The boiler is fitted with a multifunctional automatic gas valve which ensures that the precise air/gas ratio is provided under all operating conditions. The gas flow rate has been set during production and does not require adjustment. With the front casing fitted check the gas flow rate of the boiler as follows:

- Start the boiler by activating the test program P.1 as described in section 8.2.
- In addition, ensure that maximum heat can be dissipated into the heating system by turning up the room thermostat.
- Alternatively, for ecoTEC combination boilers fully open the hot water taps to ensure full flow rate through the boiler.
- Wait at least 5 minutes until the boiler has reached its operating temperature.
- Ensure that all other gas appliances in the property are turned off.
- Measure the gas flow rate at the gas meter.
- Check that the gas flow rate is as stated in Table 5.1.

5 Commissioning Part I

Boiler	Nominal net heat input in kW as per BS EN 483	Gas flow rate					
		Natural gas in m ³ /h			Propane in kg/h		
		nominal	+5%	-10%	nominal	+5%	-10%
ecoTEC plus 612	12.2	1.29	1.36	1.16	0.95	1.00	0.85
ecoTEC plus 615	15.3	1.62	1.70	1.46	1.19	1.25	1.07
ecoTEC plus 618	18.4	1.95	2.04	1.75	1.43	1.50	1.29
ecoTEC plus 624	24.5	2.59	2.72	2.33	1.90	2.00	1.71
ecoTEC plus 630	30.6	3.24	3.40	2.91	2.38	2.50	2.14
ecoTEC plus 637	37.8	4.00	4.20	3.60	2.94	3.08	2.64
ecoTEC plus 824	23.5	2.49	2.61	2.24	1.83	1.92	1.64
ecoTEC plus 831	31.6	3.34	3.51	3.01	2.45	2.58	2.21
ecoTEC plus 837	37.8	4.00	4.20	3.60	2.94	3.08	2.64
ecoTEC pro 24	23.5	2.49	2.61	2.24	1.83	1.92 </td <td>1.64</td>	1.64
ecoTEC pro 28	28.6	3.03	3.18	2.72	2.22	2.33	2.00

Table 5.1 Gas flow rates

- If the measured gas flow rate lies outside the tolerance limits specified in Table 5.1, do not operate the boiler and inform the Vaillant Service Solutions (0870 6060 777).

If the measured gas flow rate is within the tolerance limits shown in Table 5.1, then proceed as follows:

- Take the boiler out of operation by
 - Pressing the + and i buttons simultaneously and turn down both thermostat control knobs.
 - Only for combination boilers: Allow the boiler to cool down by turning off water taps and allow pump overrun to operate for a minimum of two minutes.
- Record the boiler maximum gas flow rate onto the Benchmark gas boiler commissioning checklist.

5.9.3 Checking the gas inlet working pressure

- Ensure that the gas inlet working pressure can be obtained with all other gas appliances in the property working.
- Remove the front casing from the boiler.
- Close the gas isolation valve of the boiler.

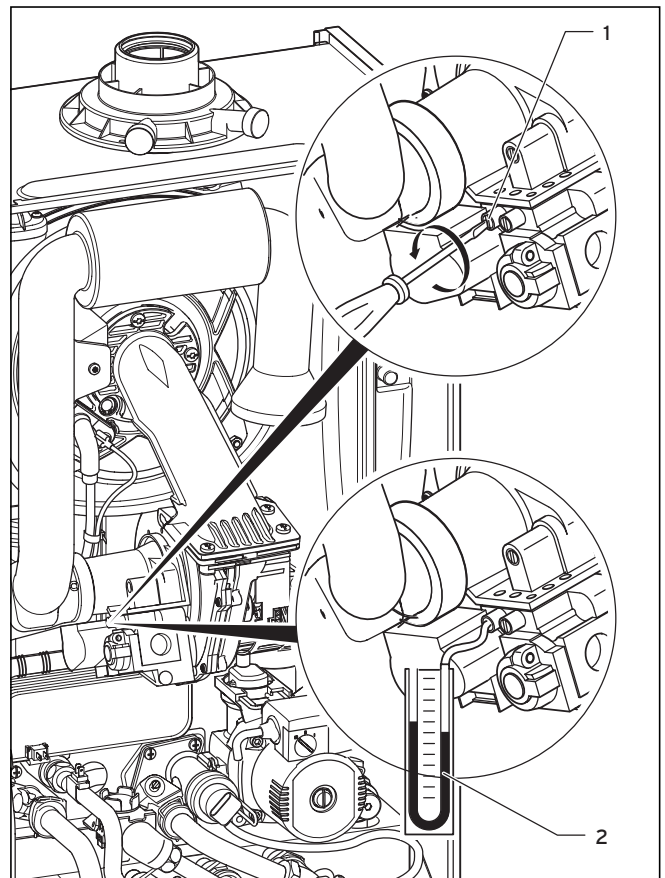

Fig. 5.8 Measuring the gas inlet working pressure

- Loosen the sealing screw marked "in" (1) on the gas valve.

- Connect a digital pressure gauge or U-tube manometer (2).
- Open the gas isolation valve of the boiler.
- Start the boiler by activating the test program P.1 as described in section 8.2.
- In addition, ensure that maximum heat can be dissipated into the heating system by turning up the room thermostat.
- Alternatively, for ecoTEC combination boilers fully open the hot water taps to ensure full flow rate through the boiler.
- With the boiler operating at full load check that the gas inlet working pressure at the reference test point (1) complies with the requirements of Table 5.2.

ecoTEC appliance	Natural gas (G20)		LPG (G31)	
	Minimum pressure at reference test point in mbar	Maximum pressure at reference test point in mbar	Minimum pressure at reference test point in mbar	Maximum pressure at reference test point in mbar
ecoTEC plus 612/615/618/624/630 824/831	16	23	23	43
ecoTEC pro 24/28				
ecoTEC plus 637/837	15	23	23	43

Table 5.2 Gas inlet working pressures at the reference test point

- Should the pressure recorded at the reference test point in the boiler be lower than indicated (Table 5.2) check if there is any blockage in the pipework or if the pipework is undersized.
- If the supply pressure is out of tolerance contact your Emergency Service Provider.

If the gas inlet working pressure at the reference test point (1) is **not** within the permissible range and you cannot correct the failure, notify the gas supply company or the Vaillant Service Solutions team and proceed as follows:

- Take the boiler out of operation by
 - Pressing the + and i buttons simultaneously and turn down both thermostat control knobs.
 - Only for combination boilers: Allow the boiler to cool down by turning off water taps and allow pump overrun to operate for a minimum of two minutes.
- Close the gas isolation valve of the boiler.
- Remove the pressure gauge and re-tighten the sealing screw (1).
- Turn on gas at the gas isolation valve.
- Make sure that there is no leakage at the sealing screw.
- Turn off gas at the gas isolation valve.

- Put the front casing back on.
- Turn off electrical supply to the boiler.
- You must not start up the boiler.

If the gas inlet working pressure is within the permissible range, proceed as follows:

- Take the boiler out of operation by
 - Pressing the + and i buttons simultaneously and turn down both thermostat control knobs.
 - Only for combination boilers: Allow the boiler to cool down by turning off water taps and allow pump overrun to operate for a minimum of two minutes.
- Close gas isolation valve of the boiler.
- Remove the pressure gauge and re-tighten the sealing screw (1).
- Open the gas isolation valve of the boiler.
- Make sure that there is no leakage at the sealing screw.
- Put the front casing back on.
- Reset boiler controls for normal operation.
- Record the appliance gas inlet working pressure (mbar) in the Benchmark gas boiler commissioning checklist.

5 Commissioning Part I

5.10 Refitting the case

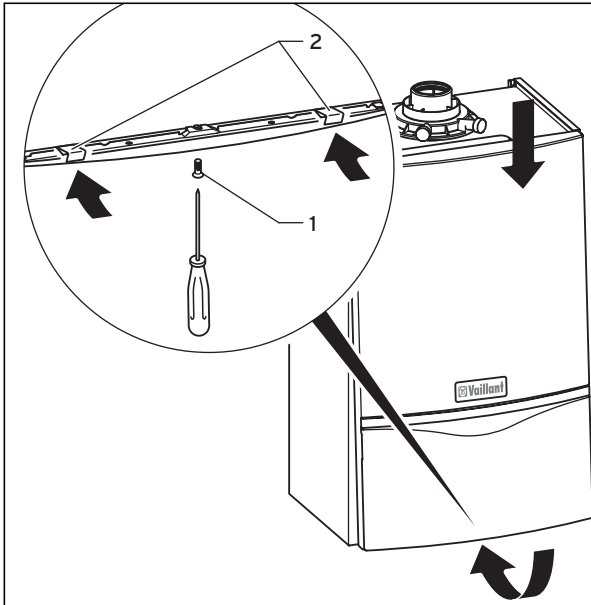

Fig. 5.9 Refitting the case

- Hook the top of the front casing over the lip on the top of the boiler chassis and push the bottom of the front casing into place.
- Ensure the spring retaining clips (2) engage correctly.
- Tighten case securing screw (1).

5.11 Adjusting the central heating output (range rating)

The boilers are fully modulating for central heating, and it is therefore not necessary to range rate the boiler. However, if desired, it is possible to range rate the boiler, as follows:

- Press the "i" and "+" buttons simultaneously.
- Keep the "+" button pressed until "d.0" is displayed.

Note

The display runs from "d.0" to "d.99" before restarting at "d.0".

- Press the "i" button. The "=" symbol is displayed. The part load setting is now displayed in kW.
- Use the "+" and "-" buttons to increase or decrease the value in steps of 1 kW. The displayed value will flash while the adjustment procedure is being carried out. The available ranges of settings are given in Table 5.3.
- Push the "i" button for about five seconds, or until the display stops flashing. The value is now saved to memory. The display will now return to its normal state (current heating system flow temperature, e.g. 45 °C).
- Press the "i" and "+" buttons simultaneously to cancel adjustment mode. Adjustment mode is also cancelled if no button is operated for a period of 4 minutes.

Appliance	Heating output in kW
ecoTEC plus 612	5 - 12
ecoTEC plus 615	5 - 15
ecoTEC plus 618	7 - 18
ecoTEC plus 624	9 - 24
ecoTEC plus 630	10 - 30
ecoTEC plus 637	12 - 37
ecoTEC plus 824	7 - 19
ecoTEC plus 831	9 - 24
ecoTEC plus 837	12 - 28
ecoTEC pro 24	7 - 19
ecoTEC pro 28	9 - 24

Table 5.3 Heating system part load adjustment ranges

5.12 Gas changeover



Note

To reset the appliance from natural gas to LPG mode, you need the Vaillant conversion kit Art. No. 00 20010641.

To reset the appliance from LPG to natural gas mode, you need the Vaillant conversion kit Art. No. 00 20010642.

Convert the appliance as described in the conversion kit.

6 Functional checks (commissioning part II)

6.1 Functional checks

6.1.1 Procedure

After installing and checking the gas supply pressure, perform a function check before commissioning the appliance and handing over to the user.

- Commission the appliance according to the relevant operating manual.
- Check the gas supply pipe, exhaust system, heating system and the hot water lines (combination boilers only) for leaks.
- Check that the flue system has been installed properly according to the flue system assembly manual.
- Check for ignition and an even flame on the burner.
- Perform a function check on the heating system (see section 6.1.2) and the water heating (combination boilers only, see section 6.1.3).
- Hand over the appliance to the user (see section 6.2).

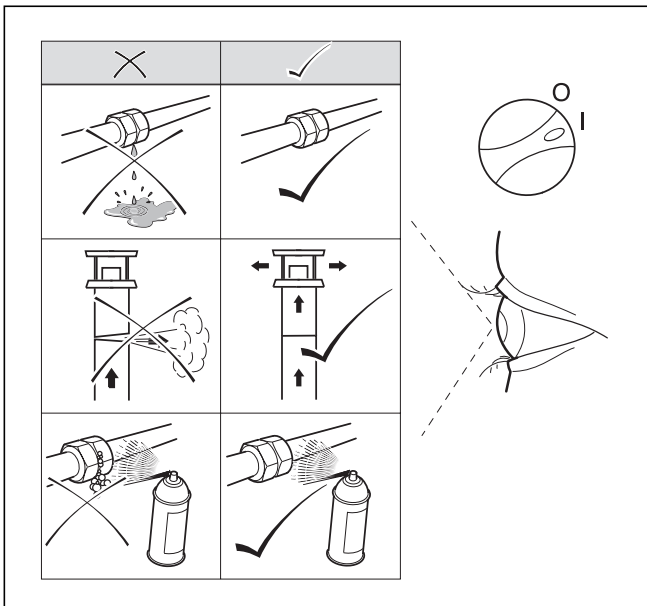

Fig. 6.1 Function check

6.1.2 Heating

- Switch on the appliance.
- Make sure that there is a heating demand.
- Press "i" to activate the status indicator.

As soon as a heat demand is received, the appliance runs through the status indicators "S. 1" to "S. 3", until the appliance is running correctly in normal mode and the display shows "S. 4".

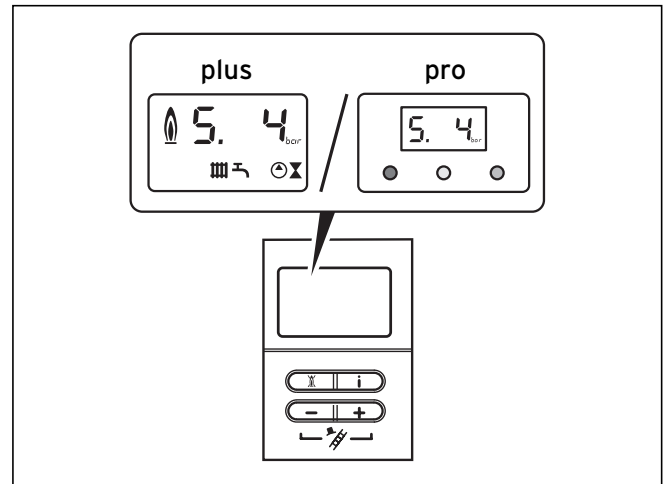

Fig. 6.2 Display indicator during heating mode

6.1.3 Water heating (combination boilers only)

- Switch on the appliance.
- Fully open the hot water tap.
- Press "i" to activate the status indicator.

If the water heating is working correctly, the display shows the following: "S.14".

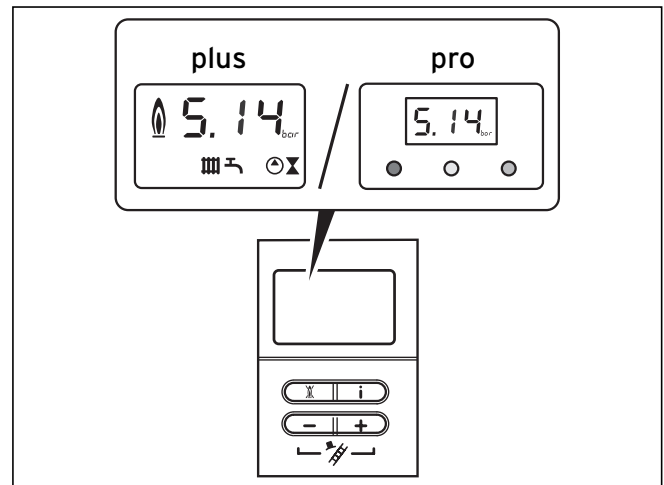

Fig. 6.3 Display indicator during water heating

6.1.4 Final flush of the heating system ("hot")

- Operate the appliance until the appliance and the heating system are up to temperature.
- Check the heating system for leaks.
- Connect a hose to the drain valve located at the lowest position of the heating system.
- Shut off the appliance, open the drain valve and all bleed valves on the radiators and allow the water to flow out of the heating system and the boiler quickly and fully.
- Close the drain valve.
- Fill the heating system again with water as described in Section 5.4.4.

6 Functional checks (commissioning part II)

- Release water from the system until the system design pressure of 1.0 bar is attained. (The actual reading on the digital pressure gauge should ideally be 0.5 bar plus an additional pressure corresponding to the highest point of the system above the base of the boiler - 10 m head equals an additional 1 bar reading on the pressure gauge. The minimum pressure should not be less than 1 bar in any installation.) If the system is to be treated with an inhibitor it should be applied at this stage in accordance with the manufacturer's instructions.

Further information can be obtained from Sentinel, Betz Dearborn Ltd., Tel: 0151 420 9595, or Fernox, Alpha-Fry technologies. Tel: 0870 8700362.

- Refit the boiler casing (see section 5.10).
- Only in ecoTEC plus appliances: Attach the bottom cover to the boiler by sliding the front edge of the cover into the lip at the bottom front edge of the appliance chassis.
- Carefully push the rear of the bottom cover upwards until the spring retaining clips engage at the side of the appliance. It may be necessary to adapt the bottom cover by removing the easy break sections.

6.2 Handing over to the user



Note

When you have finished the installation, attach the sticker supplied (835593) to the appliance in the user's language.

- Set the maximum radiator temperature control to the desired setting.
- Set the maximum hot water temperature control to the desired setting.
- Instruct the user in the safe and efficient operation of the boiler, in particular the function of
 - the boiler on/off control
 - the maximum radiator temperature control
 - the maximum hot water temperature control (combination boilers only)
 - the pressure gauge.
- Show the user how to operate any external controls.
- Explain to the user the importance of having the boiler regularly serviced by a competent servicing company. To ensure regular servicing, it is strongly recommended that arrangements are made for a Maintenance Agreement. Contact Vaillant Service Solutions (0870 6060 777) for further details.
- Record central heating operating pressure in the Benchmark gas boiler commissioning checklist along with the heat input (kW) and temperature difference between flow and return.
- Leave the user instructions and the installation instructions with the user.
- Go through the operating manual with the user and answer any questions.
- Draw special attention to the safety instructions, which the user must follow.

- Instruct the user about the methods used for combustion air supply and flue conducting. In particular, point out that these measures must not be altered.
- Inform the user that the instruction manuals should be kept near the appliance.

6.3 Factory guarantee

Two year guarantee for ecoTEC plus appliances

Vaillant undertakes to rectify any manufacturing defect that occurs within twenty-four months of the installation date.

For the 2nd year of the guarantee to be valid an annual service must be carried out by a competent person approved at the time by the Health and Safety Executive one year after installation.

The cost of this annual service is not included in the guarantee.

One year guarantee for ecoTEC pro appliances

Vaillant undertakes to rectify any manufacturing defect that occurs within twelve months of the installation date.

Registering with us

Registration is simple. Just complete the Guarantee Registration Card and return to Vaillant within 30 days of installation. Your details will then be automatically registered within the Vaillant scheme.

Note: No receipt will be issued.

Immediate help

If your Vaillant boiler develops a fault your first action should be to contact your installer, as his professional assessment is needed under the terms of our Guarantee.

If you are unable to contact your installer, phone Vaillant Service Solutions: 0870 6060 777.

7 Inspection and maintenance

7.1 Inspection and maintenance intervals



Danger!

Risk of injury and risk of damage to property due to neglected inspection and maintenance! Neglected inspection and maintenance works or not observing the stated inspection and maintenance intervals can interfere with the operational safety of the boiler and can result in damage to property and to persons.

- **Point out to the operator that he must observe the demanded inspection and maintenance intervals as a minimum.**
- **Carry out proper regular inspections once a year.**
- **Carry out regular maintenance as dictated by findings during the inspection process. The frequency of maintenance must not be longer than every 5 years.**



Danger!

Danger of life and limb due to improper inspection/maintenance! Inspections/Maintenance work carried out improperly can result in leakages and explosion.

- **The boiler may only be inspected/maintained by a competent person.**

All service work must be carried out by a competent person in accordance with the Gas safety, installation and use regulations. In the UK this is considered to be a person approved at the time by the Health and Safety Executive.

In addition BS 6798: 2009 "Specification for installation and maintenance of gas-fired boilers of rated input not exceeding 70 kW net" advises that:

- The person carrying out a combustion measurement must be assessed as competent in the use of a flue gas analyser and the interpretation of the results.
- The flue gas analyser used must be one meeting the requirements of BS7927 or BS-EN50379-3 and be calibrated in accordance with the analyser manufacturers' requirements.
- Competence can be demonstrated by satisfactory completion of the relevant ACS standard assessment, which covers the use of electronic portable flue gas analysers' in accordance with BS 7967, parts 1 to 4.
- The flue gas analyser is set to the correct fuel setting.

We recommend the conclusion of an inspection and maintenance contract with an approved company or installer. The inspection serves to determine the actual condition of the respective boiler and compare it with the specified condition. This is done by measuring, checking and observing. Maintenance is required in order to eliminate any deviations of the actual condition from the specified condition. This nor-

mally is done by cleaning, adjustment and, if necessary, replacing individual components that are subject to wear.

You must carry out an annual inspection of the Vaillant ecoTEC.

It is possible to perform a quick, accurate inspection without removing components by requesting data from the DIA system, carrying out the simple visual checks indicated in Table 7.2 and performing a flue gas measurement.

The maintenance intervals (at least once every 5 years) and their scope are determined by the heating engineer based on the condition of the boiler found during the inspection.

All inspection and maintenance work should be performed in the order specified in Table 7.2.



Danger!

Possible poisoning and burning by escaping hot flue gases!

It is possible that hot flue gases escape and could result in poisoning or burning, if the boiler is operated

- **without a completely installed air/flue gas duct**
 - **with an opened air/flue gas duct**
 - **with internal leakages and an opened front casing.**
 - **Operate the boiler**
 - **for commissioning**
 - **for testing purposes**
 - **in continuous mode**
- only with closed front casing and completely mounted and closed air/flue gas duct.**

7.1.1 General inspection and maintenance instructions

To ensure the faultless operation, long term availability of all functions and long working life of your Vaillant boiler and to prevent modifications to the approved series status only genuine Vaillant spare parts must be used when carrying out inspection, maintenance and repair work.

For an overview of the available original Vaillant spare parts, contact the Vaillant sales office on 01634 292310.

During any inspection and maintenance or after change of parts of the combustion circuit, the following must be checked:

- The appliance has been installed in accordance with the relevant installation instructions.
- The integrity of the flue gas installation and flue seals is in accordance with the relevant flue installation instructions enclosed.
- Visual, the integrity of the boiler combustion circuit and relevant seals.
- The gas inlet working pressure at maximum rate as described in section 5.9.3.
- The gas flow rates as described in section 5.9.2.

7 Inspection and maintenance

- Correctness of electrical, water and gas connections.
 - Correctness of the water pressure.
 - The condition of the whole system, in particular the condition of radiator valves, evidence of leakage from the heating system and dripping taps.
- Correct any faults before proceeding.

7.1.2 Safety instructions



Danger!

Danger of life and limb by electric shock!

The supply terminals of the boiler are under mains voltage even if the boiler main switch is off.

- Don't touch the supply terminals.
- Protect the electronic box from any water or spray.
- Before working on the boiler, turn off the power and secure against restart.



Note

If it is necessary to keep the electricity to the boiler switched on for certain inspection and maintenance, this is indicated in the description of the maintenance task.

Always perform the following steps **prior** to inspection or maintenance work:

- Switch off the main switch.
- Disconnect the boiler from the power mains by
 - disconnecting the mains plug or
 - de-energising the boiler via an isolating device with a contact opening of at least 3 mm (e. g. fuses or power switches).
- Further check for electrical isolation of the appliance by use of a test meter.
- Close the gas isolator cock.
- Close the service valves in the heating flow and return.
- Remove the front casing from the boiler.
- When removing any water carrying components ensure that water is kept away from all electrical components.

Always perform the following steps after performing any inspection or maintenance work:

- Always use new seals and O-rings when parts are replaced.
- Open the service valves in the heating flow and return.
- Reconnect the boiler to the power mains.
- Switch the main switch on.
- Fill the heating circuit of the boiler to a pressure of between 1.0 and 2.0 bar if required.
- Bleed the heating installation (see section 5.4, Filling and bleeding the heating system).
- Open the gas isolator cock.

- Check the boiler for gas and water leaks.
- If necessary, refill and re-bleed the heating installation.
- Replace the front casing to the boiler.
- Carry out a functional check of the boiler (see section 6).
- Always check earth continuity, polarity and resistance to earth with a multimeter after any service work and after replacing any electrical component.

7.1.3 Checking the CO₂ concentration



Note

Checking/adjustment of the CO₂ concentration is required in the following instances:

- replacement of gas valve,
- conversion to or from Natural Gas/LPG
- or if an incorrect combustion is suspected.

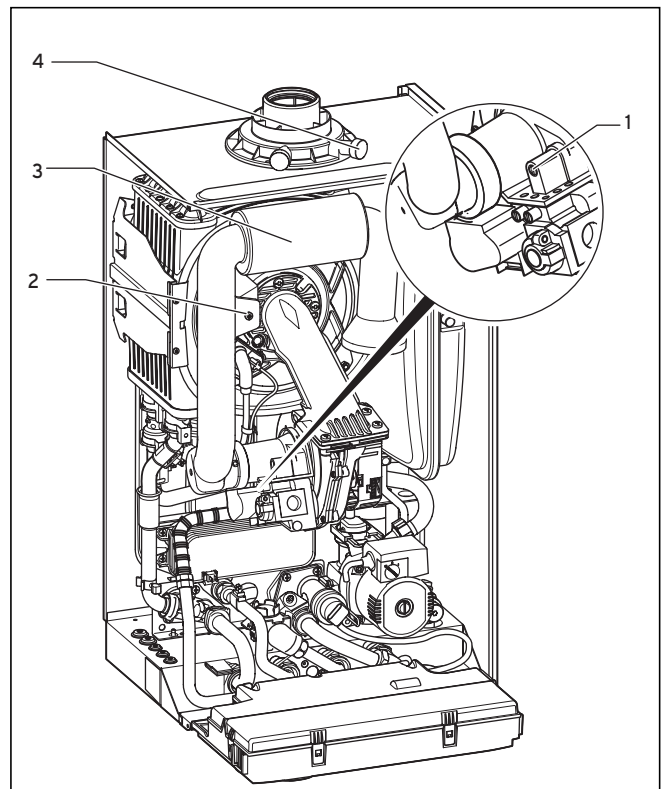

Fig. 7.1 Measuring the CO₂ concentration, specifying the air ratio (gas setting)

Legend:

- 1 Main throttle
- 2 Screw
- 3 Air intake pipe
- 4 Flue gas analysis point



Note

The boiler is fitted with a flue gas analysis point (4). A suitable flue gas analyser can be connected to this point to establish the combustion performance of the boiler.

- Remove the front casing.
- Start the testing program P.1.
- Wait at least 5 minutes until the boiler reaches its operating temperature.
- Measure the CO₂ concentration at the flue gas analysis point (4). Compare the measured value with the corresponding value in Table 7.1.
- If all these points are as required, proceed as described in section 7.1.5.
- If one of the flue gas values is greater than the acceptable values in Table 7.1, then proceed as described in the following section 7.1.4.

7.1.4 Adjusting the CO₂ concentration (or the air ratio)



Danger!

Increased risk of poisoning due to incorrect settings!

Incorrect setting may increase the risk of poisoning.

- **If one of the flue gas values is greater than the acceptable values in Table 7.1 then check**
 - the integrity of the complete flue gas installation
 - the integrity of the combustion circuit seals
 - the gas inlet working pressure
 - the gas flow rate.

If the flue gas value needs to be adjusted,

- unfasten the screw (Fig. 7.1, **2**) and
- fold the air intake pipe (Fig. 7.1, **3**) forwards through 90°. Do not remove the air intake pipe.
- Specify the required flue gas value if necessary (value with front casing of boiler removed, see Table 7.1) by turning the screw of the main throttle (Fig. 7.1, **1**).



Note

Use a 4 mm hexagon socket spanner to turn the screw.

- Turn to the left: higher CO₂ concentration,
- Turn to the right: lower CO₂ concentration.



Note

Natural gas: Only perform the adjustment in increments of 1/8 turn and wait approximately 1 minute after each adjustment until the value stabilises.

Liquid gas: Only perform the adjustment in very small increments (approximately 1/16 turns), and wait approximately 1 minute after each adjustment until the value stabilises.

- After performing the adjustments, fold the air intake pipe back up.
- Check the CO₂ concentration once again.
- If necessary, repeat the setting process.
- Push the „i“ button to deactivate the full load mode. The full load mode is also deactivated if no button is pushed for 15 minutes.
- The adjusting screw shall be sealed after the adjustment.
- Re-secure the air intake pipe with the screw (**2**).
- Put the front casing back on.

Settings	Natural gas (H) Tolerance	Propane Tolerance	Unit
CO ₂ after 5 min. full load mode with appliance front closed	9.2 ± 1,0	10.2 ± 0,5	Vol.-%
CO ₂ after 5 min. full load mode with appliance front removed	9.0 ± 1,0	10.0 ± 0,5	Vol.-%
Set for Wobbe-Index W ₀	15	22.5	kWh/m ³
CO value with full load	< 250	< 250	ppm
CO/CO ₂	< 0,0031	< 0,0026	

Table 7.1 Factory gas setting



Danger!

Risk to life due to poisoning!

CO is an extremely toxic gas. Risk to life due to excessive CO concentrations.

- **If you are not able to adjust the boiler correctly and the flue gas values remain higher than allowed in Table 7.1, call the Vaillant Service Solutions.**
- **Do not start up the boiler!**

7 Inspection and maintenance

7.1.5 Inspection and maintenance work steps

No.	Activity	Column 1 Inspection must be carried out each year	Column 2 Maintenance must be carried out at regular intervals - but no longer than 5 years
1	Check the air flue gas installation for leaks and for proper fixation and ensure it is not blocked or damaged and is fitted correctly, complying with the relevant installation instructions.	x	x
2	Carry out a general inspection of the boiler for dirt and dust and clean as necessary.	x	x
3	Visually inspect the complete heat engine for its general condition and for signs of corrosion, sooting or other forms of damage. If damage is evident proceed to column 2.	x	x
4	Measure the gas flow rate during operation with maximum load (Kap. 5.9.2). If the gas flow rate complies to the Table 5.1 continue with column 1, if not proceed to column 2.	x	x
5	Check the gas inlet working pressure (Kap. 5.9.3) operation with maximum load. If the gas inlet working pressure complies to the Table 5.2 continue with column 1, if not proceed to column 2.	x	x
6	Check combustion by measuring CO, CO ₂ and CO/CO ₂ . If the values are outside the tolerances of Table 7.1 proceed to maintenance column 2. You must not proceed with the maintenance if a new burner door seal kit is not available.	x	
7	Isolate the boiler from the power mains. Check whether the electrical plug connections and the other electrical connections are fitted tightly and correct them if necessary.	x	x
8	Close the gas isolator cock and the service valves.		x
9	Dump the pressure in the boiler on the water side (observe pressure gauge) and check the charge pressure of the expansion vessel. Top up if necessary.		x
10	Remove the compact thermal module.		x
11	Check the integrity of all combustion circuit seals, especially the burner door seal. If there are any damages repair them before proceeding.		x
12	Clean the heat exchanger.		x
13	Check whether the burner is dirty and clean it if necessary.		x
14	Check the condensate siphon in the boiler, clean and fill if necessary.	x	x
15	Check the condensate ducts in the boiler and clean if necessary.	x	x
16	Install the compact thermal module. Caution: Use new seals and nuts!		x
17	Open the service valves and fill up the boiler/appliance to approximately 1.0 - 2.0 bar (depending on the static height of the system). Start the bleeding program P.O.		x
18	Open the gas isolator cock, reconnect the boiler with the power mains and switch on the boiler.	x	x
19	Perform a test operation of the boiler and heating installation, including water heating and bleed again if necessary.	x	x
20	Check visually the ignition and burner performance.	x	x
21	Check the boiler for leaks of any kind (gas, flue gas, water, condensate) and rectify as necessary.	x	x
22	If you had problems with the CO, CO ₂ , CO/CO ₂ -values in Step 6 before the maintenance, check them again now (see Table 7.1). If they are outside of the tolerances of Table 7.1 make an adjustment, see section 7.1.4.		x
23	Complete the gas commission checklist (benchmark book).	x	x

Table 7.2 Inspection and maintenance steps

7.2 Servicing the burner module

7.2.1 Removing the burner module

The burner module consists of the burner, fan, gas valve and the gas supply (mixer tube). These four components make up the complete assembly, the burner module.



Danger!

There is danger of being injured or burnt by the burner module and at all components carrying water. Only carry out work on these components once they have cooled down.

Proceed as follows to remove it:

- Turn off the boiler
- Isolate the electrical supply to the boiler.
- Remove boiler bottom cover by releasing the two spring retaining lugs and lowering the rear of the bottom cover.
- Gently pull the bottom cover backwards to remove from the appliance.
- Turn off the gas service valve.
- Turn off the boiler CH service valves.
- Loosen screw, release the front case spring retaining clips located beneath the front edge of the appliance.
- Remove the front casing by easing forward the bottom edge and gently lifting.
- Lower electronic control box.

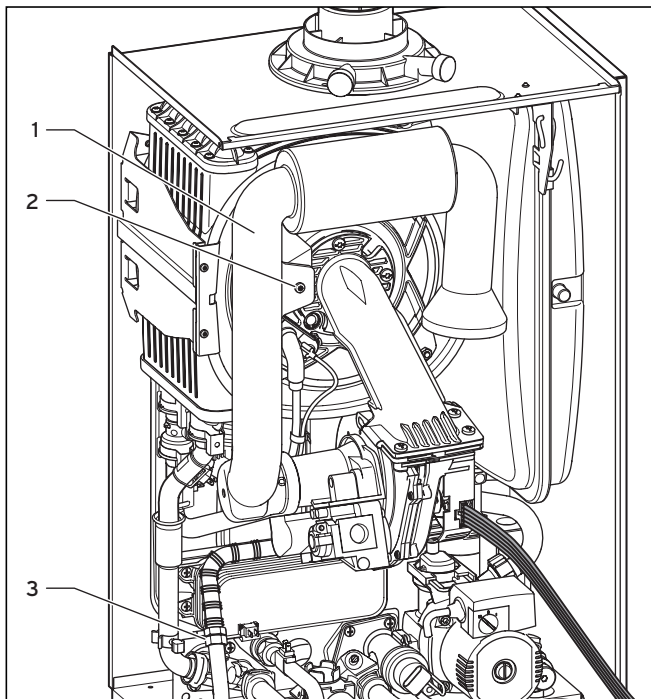

Fig. 7.2 Dismantling air intake pipe

- Remove screw (2) and remove the air intake pipe (1).

- Disconnect the gas supply (3) on the gas valve. Ensure the corrugated gas pipe does not twist by holding the flattened section of the pipe, with an open ended spanner, whilst loosening the union nut.



Caution!

**Damage to corrugated gas pipe!
Under no circumstances must the burner module be suspended from the flexible corrugated gas pipe.**

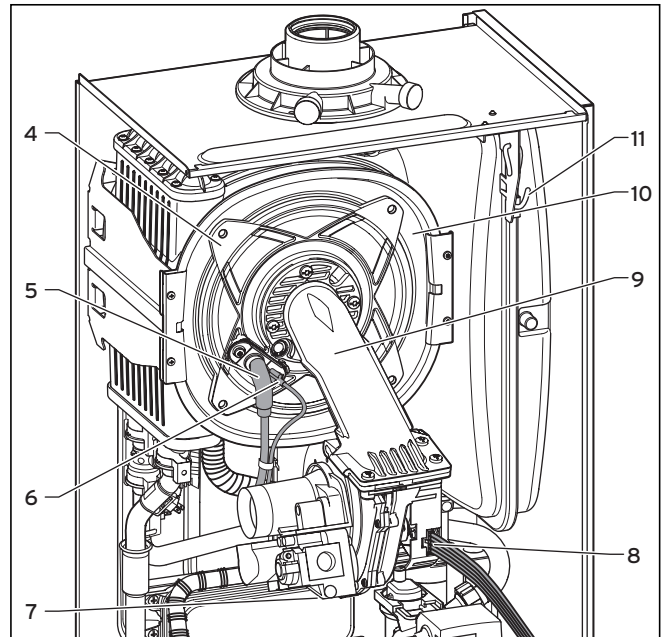

Fig. 7.3 Dismantling burner module

- Disconnect HT lead (5) and earth lead (6) from spark electrode.
- Remove four nuts (4) from burner manifold.
- Disconnect two electrical connections (7 and 8) from fan and gas valve.
- Pull forward and remove burner, gas valve and fan assembly (9) from integral condensation heat exchanger (10).



Note

You can suspend the burner module on the hook (11) while carrying out maintenance tasks.

- After removing the thermal compact module, clean the components as described below.

7 Inspection and maintenance

7.2.2 Cleaning the integral condensation heat exchanger



Caution!
Protect the electronics box against sprayed water.

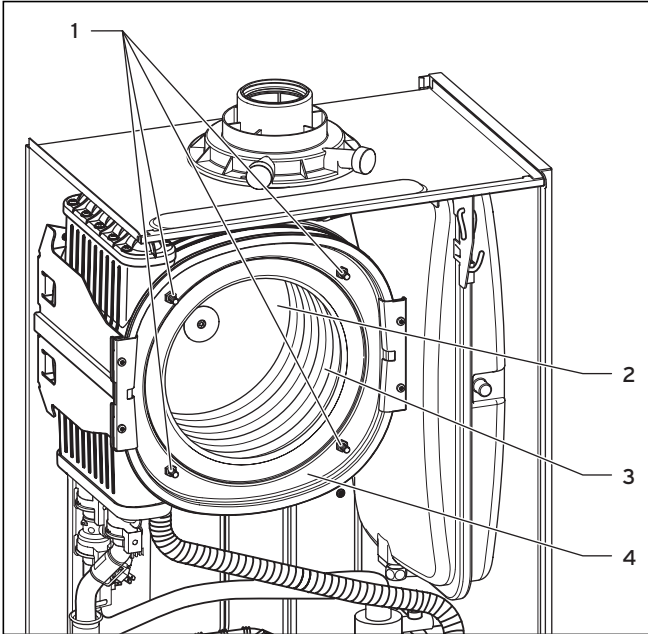

Fig. 7.4 Cleaning the integral condensation heat exchanger

- Dismantle the burner module as described under 7.2.1.



Caution!
Risk of damaging the primary heat exchanger!
• Do not attempt to loosen nor retighten the four screws (1).

With the burner and fan assembly removed it is now possible to inspect the main heat exchanger (4).

- Remove any loose deposits from the heating spirals (3) using a soft brush and jet of water (ensure that water is kept away from all electrical components. Any water used to clean the main heat exchanger will drain through the condensate trap). Avoid pointing the water jet directly at the insulating surface (2) on the back of the heat exchanger.

If required the heat exchanger can be cleaned using regular vinegar.

7.2.3 Checking the burner

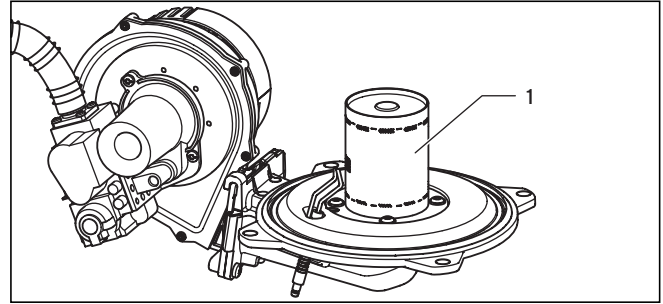

Fig. 7.5 Checking burner

The burner (1) is maintenance-free and needs no cleaning.

- Check the burner surface for damage, replace the burner if necessary.
- After checking/replacing the burner, re-assemble the burner module in the boiler as described in Section 7.2.4.

7.2.4 Refitting the burner module

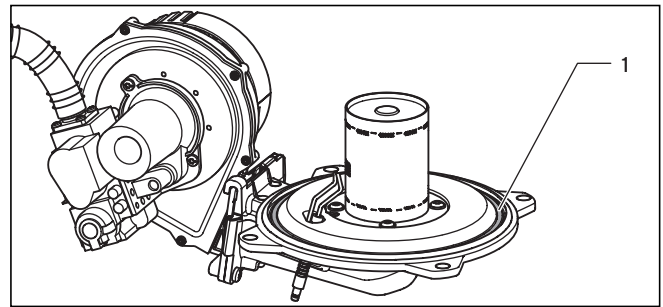

Fig. 7.6 Replacing the burner door seal

- Insert a new seal (1) in the burner door.



Caution!
The burner door seal (1) and the self-locking nuts on the burner module must be replaced each time the module is removed (for example during maintenance, see Table 7.1).
If the burner flange insulation on the burner module shows any signs of damage other small cracks it must also be replaced.

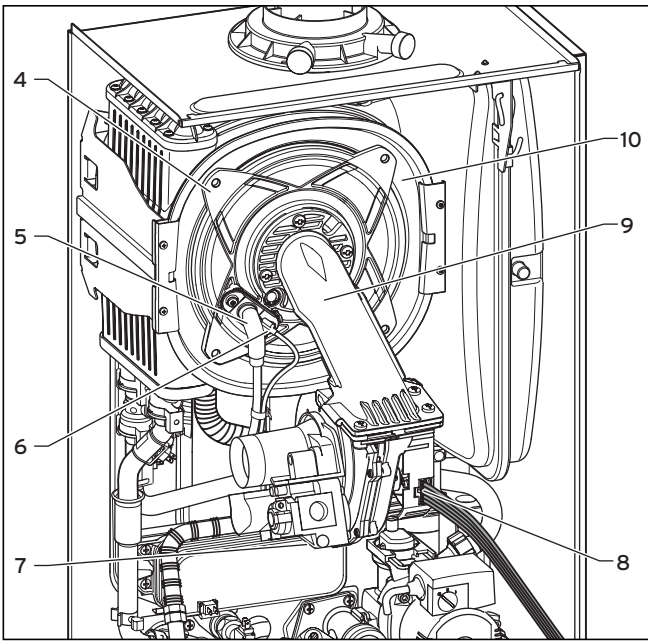

Fig. 7.7 Refitting the burner module

- Insert the burner module (9) in the integral condensation heat exchanger (10).
- Tighten the four nuts (4) on the alternate left and right sides until the burner door fits closely and uniformly to the stop surfaces.
- Reconnect the HT lead (5) and earth lead (6) to the spark electrode.
- Insert the cables (8) on the fan motor and the cable (7) on the gas fitting.

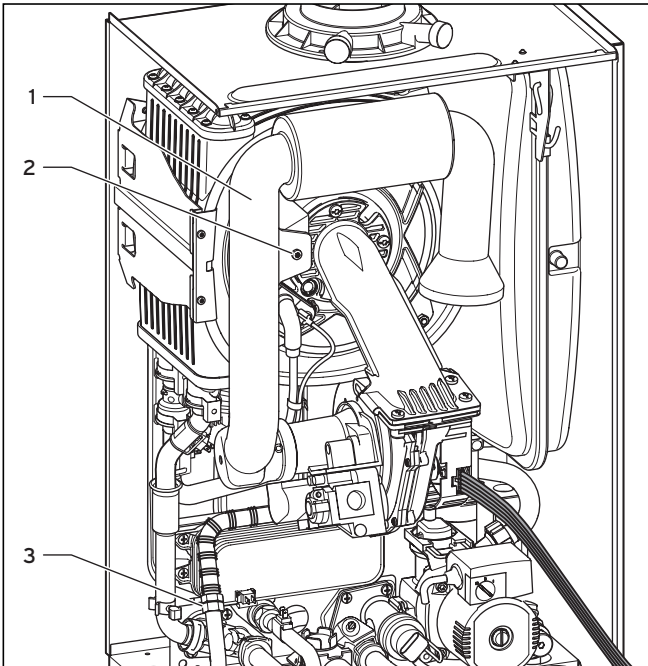

Fig. 7.8 Refitting the gas supply

- Reconnect the gas supply (3) to the gas valve, ensuring that a new sealing washer is used and correctly located. Use the spanner flat at the flexible gas line to hold the gas fittings.

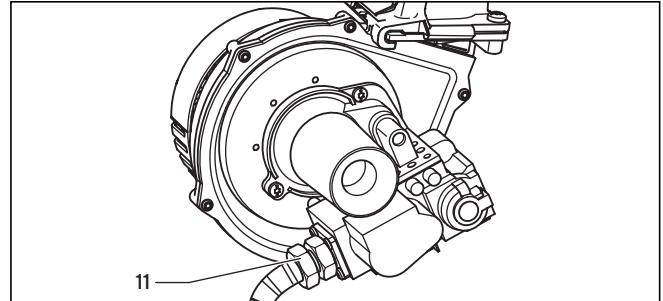

Fig. 7.9 Testing the gas supply for soundness

- Turn on the gas supply and test for soundness. Check especially the screwed connections (3) and (11).
- Refit the air inlet pipe, ensuring that the blue seal in the air intake pipe is correctly located.

7.3 Cleaning the condensate siphon



Danger!

Note that if the boiler is run with an empty condensate trap there is a danger that fumes might escape into the room and cause poisoning. For this reason, it is important to ensure that the trap is topped up each time the unit is cleaned.

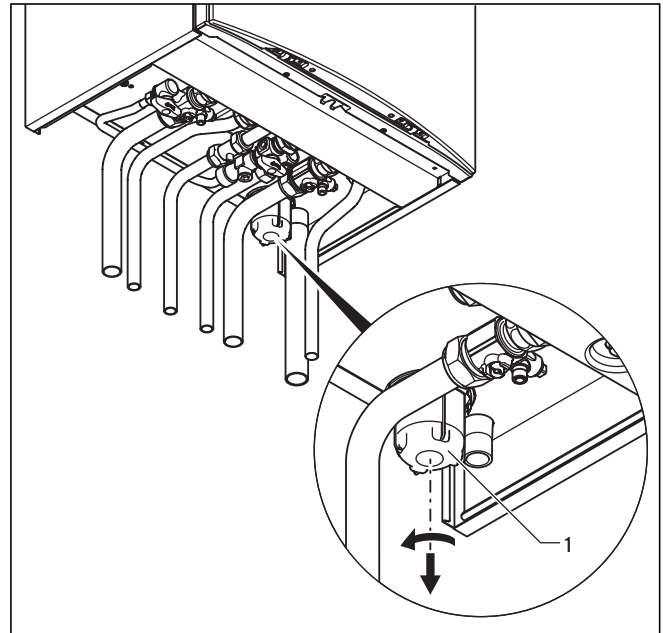

Fig. 7.10 Cleaning the condensate siphon

- Remove the lower part (1) of the condensate siphon by turning the bayonet catch in anticlockwise direction.

7 Inspection and maintenance

- Clean the siphon part section by rinsing it out with water.
- Fill the lower part with water until about 10 mm below the upper edge.
- Fasten the lower part again on the condensate siphon.

7.4 Checking the expansion vessel

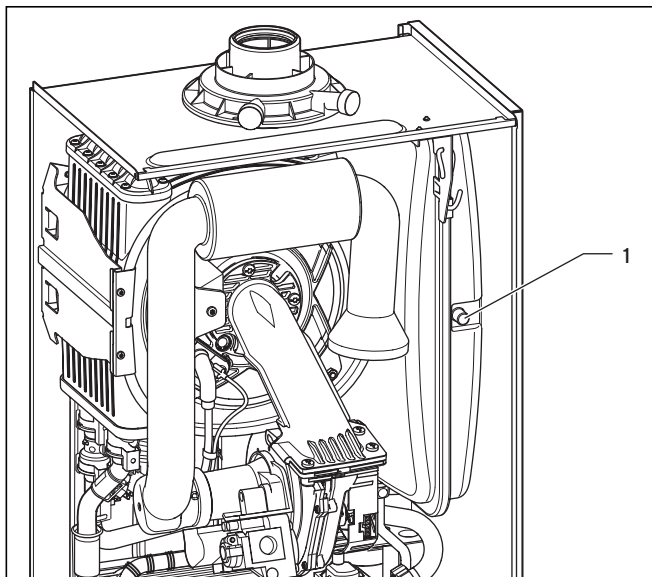

Fig. 7.11 Checking expansion vessel admission pressure

Note
It is not necessary to perform this check every year - a check every three years is sufficient.

- Ensure the boiler CH service valves are closed.
- Release the pressure from the boiler.
- Remove valve cap from expansion vessel charge point.
- Check that the internal charge pressure of the expansion vessel is between 0.75 and 0.9 bar.
If the pressure is lower than this the vessel should be repressurised using an air pump.
- Refit the valve cap.
- Repressurise boiler and heating system.

7.5 Recommissioning the boiler

- Carry out electrical safety checks.
- Turn on the electrical supply.
- Open the boiler CH service valves.
- Carry out function checks of boiler operation as previously detailed.
- Check gas flow rate as previously detailed.
- Check for water leaks.
- Refit case, ensuring that a good seal is obtained.

7.6 Test operation

Always perform the following checks after completing any maintenance task:

- Commission the appliance according to the relevant operating manual.
- Check the appliance for gas and water leaks.
- Check the air/flue gas installation for leaks, check its fastening.
- Check for ignition and an even flame on the burner.
- Check that the heating system and the water heating is working (combination boilers only).
- Fill out the Benchmark gas boiler commissioning checklist at the rear of this guide.

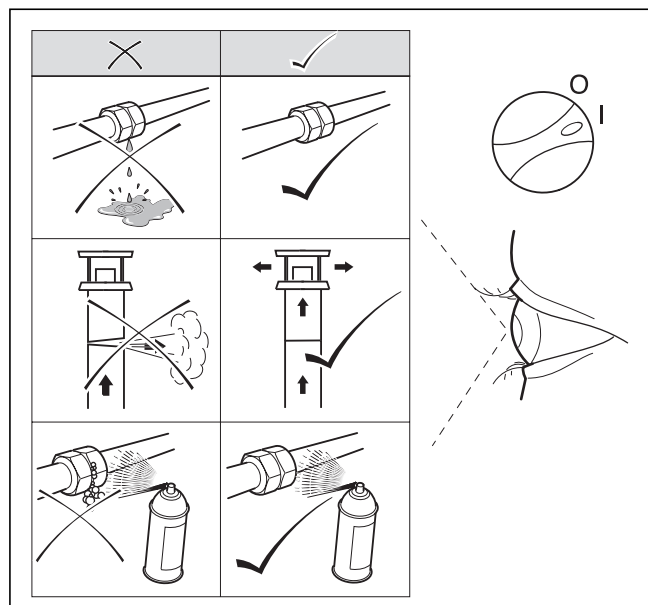

Fig. 7.12 Function check

8 Troubleshooting

8.1 Logical fault finding procedure

These checks must be carried out before attempting to use the fault finding guide.

1. Carry out electrical safety checks (see section 'Preliminary Electrical Checks').
2. Check that the external electricity supply to the boiler is on, and a supply of 230 V~ is present between boiler terminals 'L' and 'N'.
3. Check that the gas supply to the boiler is on, that it has been correctly purged and that an inlet pressure of 20 mbar is available at the gas valve. (See section 'Gas Supply').
4. Ensure the heating system is full of water and charged to between 1 and 1.5 bar. If not, refill and vent the system. (See section 'Filling the heating system').
Ensure boiler flow and return service valves are open.
5. Check that the main on/off control is set to the 'on' position.
6. Set the central heating temperature to maximum.
7. Set the domestic hot water temperature to maximum (combination boilers only).
8. Check that all external controls are on and calling for heat (if no external controls are fitted, boiler terminals 3 and 4 must be linked). Check that the boiler anti-cycling economiser is not engaged.

8.1.1 Status codes

The status codes that you can see on the display provides information about the current operating condition of the appliance. The display of the status codes can be called as follows:

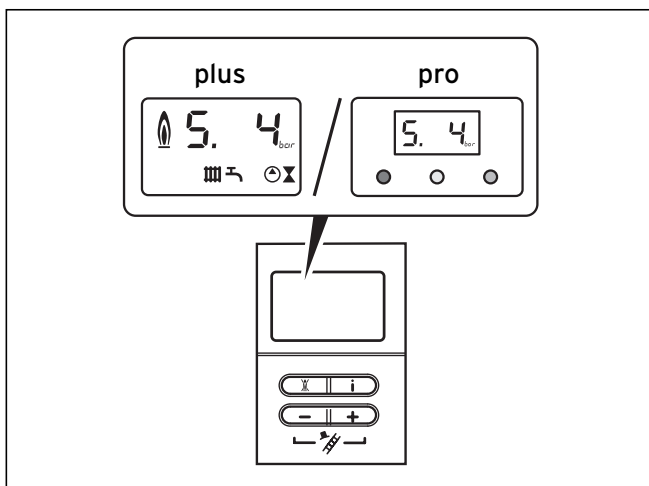

Fig. 8.1 Display of status codes

- Press the "i" key.
The display shows the status code, e.g. **S.4** for "Burner mode - Heating".

The display of the status codes can be cancelled as follows:

- Press the "i" key or
- Do not press any key for about 4 minutes.
The current heating flow temperature appears in the display again.

8.1.2 Diagnostic codes

Display	Meaning
Heating mode (all models):	
S. 0	No heat demand
S. 1	Fan running
S. 2	Water pump running
S. 3	Ignition sequence
S. 4	Burner ignited
S. 5	Fan and pump running
S. 6	Fan over run
S. 7	Pump over run
S. 8	Anti cycling mode
Domestic hot water mode (ecoTEC combination boilers only):	
S.10	Hot water demand
S.11	Fan running
S.13	Ignition sequence
S.14	Burner ignited
S.15	Fan and pump running
S.16	Fan over run
S.17	Pump over run
Warm start (ecoTEC combination boilers only) / Charge hot water cylinder (ecoTEC system boilers only):	
S.20	Warmstart demand
S.21	Fan running
S.22	Pump running
S.23	Ignition sequence
S.24	Burner ignited
S.25	Fan and water pump running
S.26	Fan over run
S.27	Pump over run
S.28	Anti cycling mode
All boilers:	
S.30	No heating demand from external controls (clamp 3-4 open)
S.31	Central heating thermostat knob turned off or no heat demand by the eBUS control unit
S.32	Heat exchanger antifreeze active, as fan speed variation is too high. Appliance is within the waiting time of the operation block function
S.34	Antifrost mode active
S.36	No heating demand from low voltage controls (clamp 7-8-9)
S.41	Water pressure > 2,9 bar
S.42	Response from accessory modul or defective condensate pump is blocking burner operation
S.52	Water pressure > 2,9 bar
S.53	Appliance is within the waiting period of the operation block function due to water shortage (VL-RL spread too big)
S.54	Appliance is within the waiting period of the operation block function due to water shortage (temperature gradient)
S.96	Return-sensor check is running, demand (DHW or heating) is blocked
S.97	Water pressure sensor check is running, demand (DHW or heating) is blocked
S.98	Flow-/Return-sensor check is running, demand (DHW or heating) is blocked

Table 8.1 Status codes (continued)

8 Troubleshooting

In the diagnostic mode, you can change certain parameters or display more information. The diagnostic information is divided into two diagnostic levels. The second diagnostic level can be reached only after entering a password.



Caution!

Access to the second diagnostic level must be used exclusively by a qualified technician.

First Diagnostic level

- Press the “i” and “+” keys simultaneously. The display shows “d.0”.
- Use the “+” or “-” keys to scroll through the desired diagnostic numbers of the first diagnostic level (see Table 8.2).
- Press the “i” key.

The display shows the relevant diagnostic information.

- If necessary, use the “+” or “-” keys to change the value (display flashes).
- Save the new value by holding down the “i” key for approx. 5 seconds until the display no longer flashes.

You can end the diagnostic mode as follows:

- Press the “i” and “+” keys simultaneously. or
- Do not press any key for approx. 4 minutes.

The current heating flow temperature appears in the display again.

Display	Meaning	Display value/adjustable value
d. 0	Heating part load	Adjustable heating part load in kW (factory setting: max. output)
d. 1	Water pump over run time for heating mode	2 - 60 min (factory setting: 5 min)
d. 2	Max. burner anti cycling period at 20 °C Flow temperature	2 - 60 min (factory setting: 20 min)
d. 3	Hot water flow temperature reading (combination boiler only)	in °C
d. 4	Current temperature for warm start sensor (combination boilers only) Current storage tank sensor (system boilers only)	in °C
d. 5	Flow temperature target value or return target value when return regulation is set.	in °C, max. the value set in d.71 Limited by the eBUS controller (if an eBUS controller is connected)
d. 6	Hot water temperature target value	in °C, 35 to 65 °C
d. 7	Warm start temperature target value (ecoTEC plus combination boiler only) Storage temperature target value (system boiler only)	in °C, 40 to 65 °C in °C, 15 °C for left stop, then 40 to 70 °C
d. 8	External controls heat demand (Clamp 3-4)	0 = open (no heat request) 1 = closed (heat request)
d. 9	Flow target temperature from external analogue regulator to terminal 7-8-9/eBUS	in °C, minimum from ext. eBUS target value and target value terminal 7
d.10	Status internal heating pump	1 = on, 0 = off
d.11	Status external heating pump	1 to 100 = on, 0 = off
d.12	Cylinder charging pump (via accessory module)	1 to 100 = on, 0 = off
d.13	Hot water circulation pump (via accessory module)	1 to 100 = on, 0 = off
d.22	Hot water demand	1 = on, 0 = off
d.23	Summer/Winter function	1 = Winter, 0 = Summer
d.25	Hot water activation via eBUS Control	1 = yes, 0 = no
d.30	Control signal for both gas valves	1 = on, 0 = off
d.33	Fan speed target value	in rpm/10
d.34	Fan speed actual value	in rpm/10
d.35	Position of diverter valve (combination boilers only)	0 = Heating; 100 = Hot water; 40 = Centre position

Table 8.2 Diagnostic codes of the first diagnostic level

Display	Meaning	Display value/adjustable value
d.36	Hot water flow sensor	in l/min
d.40	Flow temperature	Actual value in °C
d.41	Return temperature	Actual value in °C
d.44	Digitised ionisation potential	Display range of 0 to 102, > 80 no flame, < 40 even flame
d.47	Outside temperature (with weather compensating Vaillant controller only)	Actual value in °C
d.67	Remaining burner anti cycling time	in min
d.76	Appliance variant (device specific number)	00 to 99
d.90	Digital regulator status	1 = identified, 0 = unidentified (eBUS Address <=10)
d.91	DCF status with connected external probe with DCF77 receiver	0 = no reception, 1 = reception, 2 = synchronised, 3 = valid
d.97	Activation of the second diagnostic level	Password: 17

Table 8.2 Diagnostic codes of the first diagnostic level (continued)

Second diagnostic level

- As described above in the first diagnostic level, scroll through the diagnostic number **d.97**.
- Change the displayed value to **17** (password) and press the "i" button.

You are now in the second diagnostic level where all information from the first diagnostic level (see Table 8.2) and the second diagnostic level (see Table 8.3) is displayed.

Scrolling and changing values and exiting the diagnostic mode is done as described in the first diagnostic level.



Note

After exiting the second diagnostic level, if you press "i" and "+" within 4 minutes, you will directly reach the second diagnostic level without having to enter the password again.

Display	Meaning	Display value/adjustable value
d.17	Heating flow/return regulation changeover	0 = flow, 1 = return (factory setting: 0)
d.18	Pump mode (return)	0 = return, 1 = nonstop, 2 = winter (factory setting: 0)
d.19	Only in ecoTEC plus: Operating modes of the two-speed heating pump	0 = pre ignition speed 1, hot water or heating speed 2, overrun speed 1 1 = pre ignition speed 1, hot water speed 2, heating speed 1, overrun speed 1 2 = like 1, but speed in heating mode dependent on heating part load d. 0 (if d.0 is below 60% of full load, then pump speed 1, otherwise speed 2) 3 = always speed 2 (factory setting: 2)
d.20	Maximum set value for target cylinder temperature (system boilers only)	Setting range: 50 to 70 °C (factory setting: 65 °C)
d.27	Switching accessory relay 1 in the accessory module	1 = Circulation pump (default) 2 = Ext. pump 3 = Storage charging pump 4 = Flue gas flap/extractor hood 5 = External gas valve 6 = External error message
d.28	Switching accessory relay 2 in the accessory module	1 = Circulation pump 2 = Ext. pump (default) 3 = Storage charging pump 4 = Flue gas flap/extractor hood 5 = External gas valve 6 = External error message

Table 8.3 Diagnostics codes of the second diagnostic level

8 Troubleshooting

Display	Meaning	Display value/adjustable value
d.50	Offset for minimum speed	in rpm/10, adjustment range: 0 to 300
d.51	Offset for maximum speed	in rpm/10, adjustment range: -99 to 0
d.58	From the third quarter of 2006: Activation of solar reheating	Setting range: 0 to 3 0 = solar reheating disabled (factory setting) 3 = activation of min. hot water target value = 60 °C for solar reheating
d.60	Number of safety temperature limiter cut offs	Quantity
d.61	Number of lock outs	Number of unsuccessful ignitions in the last attempt
d.64	Average ignition time	in seconds
d.65	Maximum ignition time	in seconds
d.68	Unsuccessful ignitions in the first attempt	Quantity
d.69	Unsuccessful ignitions in the second attempt	Quantity
d.70	Set diverter valve position	0 = Normal mode (factory setting) 1 = Centre position 2 = permanent heating position
d.71	Maximum setting of heater control knob	Adjustment range in °C: 40 to 85 (Factory setting: 75)
d.72	Pump overrun time after warm start (combination boilers only) or charging an electronically controlled hot water storage through C1-C2 (system boilers only)	Adjustment range in sec: 0, 10, 20 to 600 Factory setting for combination boilers: 80 Factory setting for system boilers: 300
d.73	Offset for warm start target value (combination boilers only)	Adjustment range: -15 K to +5 K (Factory setting: 0 K)
d.75	Maximum charging time for a storage without own controller (system boilers only)	Adjustment range in min: 20, 21, 22 to 90 (Factory setting: 45)
d.77	Storage partial load (storage charging capacity limit, system boilers only)	Adjustment range in kW: appliance-specific Factory setting: max. output
d.78	Storage charging temperature limit (target flow temperature in storage mode, system boilers only)	Adjustment range in °C 55 to 90 (Factory setting: 80)
d.80	Heating operating hours	in h ⁰⁾
d.81	Water heating operating hours (combination boilers only)	in h ⁰⁾
d.82	Cycles in heating mode	Quantity/100 ⁰⁾ (3 corresponds 300)
d.83	Cycles in hot water operation	Quantity/100 ⁰⁾ (3 corresponds 300)
d.84	Maintenance indicator: Number of hours until the next maintenance	Adjustment range: 0 to 3000 h and "--" for disabled Factory setting: "--" (300 corresponds to 3000 h)
d.93	DSN appliance variant setting	Adjustment range: 0 to 99
d.96	Factory setting	1 = Resetting adjustable parameters to factory setting

1) Five-digit numbers are saved with the diagnostics codes 80 to 83. If d.80, for example, is selected, only the first two digits of the number are displayed (e. g. 10). The display switches to the last three digits (e. g. 947) by pressing "i". In this example the number of operating hours of the heating is 10947 h. The display returns to the selected diagnostics item by pressing "i" again.

Table 8.3 Diagnostics codes of the second diagnostic level (continued)

8.1.3 Fault codes

Fault codes take priority over all other display functions in the event of a system fault occurring.

If multiple faults occur, the corresponding fault codes are displayed alternately for about two seconds each.

8.1.4 Fault memory

The fault memory stores details of the ten most recent faults.

- Press the "i" and "--" buttons simultaneously.
- Use the "+" button to scroll back through the list of memorised errors.

To cancel fault error memory display mode, proceed as follows:

- Press the "i" button below the display or
- Do not touch any key for about four minutes. The display will now revert back to showing the current flow temperature.

Code	Meaning	Cause
F. 0	Flow-NTC open circuit	NTC broken, NTC cable broken, Defective connection at NTC, Defective connection at electronics
F. 1	Return-NTC open circuit	NTC broken, NTC cable broken, Defective connection at NTC, Defective connection at electronics
F.10	Flow NTC short circuit	NTC defective, short circuit in cable harness, cable/casing shortcut
F.11	Return NTC short circuit	NTC defective, short circuit in cable harness, cable/casing shortcut
F.13	Tank NTC short circuit	NTC defective, short circuit in cable harness, cable/casing shortcut
F.20	Safety temperature limiter by NTC activated	Flow-NTC not correctly thermal-connected or defective; appliance does not shut down
F.22	Dry fire	Too little water in the appliance, water pressure sensor defective, cable to pump or water sensor defective, pump blocked or defective, pump output too low
F.23	Water shortage, temperature difference between flow and return NTC too large	Pump blocked or defective, pump output too low, flow and return NTC interchanged
F.24	Water shortage, temperature rise too quick	Pump blocked, insufficient pump output, air in appliance, water pressure too low
F.25	Interruption in the compact thermal module cable harness	Compact thermal module cable harness defective
F.27	Incorrect sensing of flame	Flame detector defective
F.28	Appliance does not start: Attempts to ignite during start failed	Faults in the gas supply such as: - Gas meter or gas pressure detector defective - Air in gas - Gas flow pressure too low - Fire protection tap has disengaged Faults in the gas valve, wrong gas setting, igniter (ignition transformer, ignition cable, ignition plug) defective, ionisation current stopped (cable, electrode), faulty earthing in appliance, electronics defective
F.29	Flame goes off during operation and subsequent ignition attempts failed	Gas supply temporarily stopped, faulty earthing of appliance
F.32	Fan speed variation	Fan blocked, plug not inserted correctly on fan, hall sensor defective, fault in cable harness, electronics defective
F.49	eBUS undervoltage	Short circuit on eBUS, overload on eBUS or two power sources on eBUS with different polarity
F.61	Gas-valve control defective	Short circuit/earth (ground) leak in cable harness to gas valves, gas valve assembly defective (earth/ground leak from coils), electronic control system defective
F.62	Gas valve shutoff delay	Gas valve leaking, electronics defective
F.63	EEPROM error	Electronics defective
F.64	Electronics/NTC fault	Short-circuit in flow or return NTC or electronics defective
F.65	Electronics temperature too high	Electronics too hot due to external effect, electronics defective
F.67	Flame detector input signal is outside the limits (0 or 5 V)	Electronics defective
F.70	No valid DSN in display and/or mainboard	Spare part failure display and mainboard interchanged at same time and device specific number not adjusted
F.71	Flow NTC reports constant value (stuck at)	Flow NTC is defective
F.72	Flow and/or return NTC fault	Flow and/or return NTC is defective (tolerances too big)
F.73	Water pressure sensor signal out of range (too low)	Cable to water pressure sensor is broken or has a short-circuit at 0 V or water pressure sensor defective
F.74	Water pressure sensor signal out of range (too high)	Cable to water pressure sensor has a short-circuit at 5 V / 24 V or internal fault in water pressure sensor
F.75	No pressure rise was detected on turning on the pump	Water pressure sensor or/and pump defective Air in the heating system, quick bleeder defective Too little water in appliance; check adjustable by-pass; connect external expansion vessel to return
F.76	Overheating protection on primary heat exchanger triggered	Cable or cable connection of fuse in the primary heat exchanger defective, or primary heat exchanger defective
F.77	condensate pump or feedback of accessories blocks heating	condensate pump defective or flume flap feedback triggered
F.78	wrong configuration with accessory	link box VR65 connected to combination boiler
con	no communication to mainboard	connection error display mainboard

Table 8.4 Error codes

8 Troubleshooting

9 Parts replacement

8.2 Test programs

Special functions can be triggered on the appliances by activating various test programs.

These programs are given in detail in the Table 8.5.

- The test programs P.0 to P.6 will be started when "Power ON" is turned on and the "+" key is pressed for 5 s. The display shows "P.0".
- Press the "+" key to start counting the test number upwards.
- Press the "i" to operate the appliance now and to start the test program.
- Press "i" and "+" simultaneously to exit the test programs. You can also exit the test programs by not pressing any key for 15 minutes.

Display	Meaning
P.0	Bleeding test program. The heating circuit and hot water circuit (combination boiler only) is bled via the automatic air vent (the cap on the automatic air vent must be loosened).
P.1	Test program where the appliance is operated in full load after successful ignition
P.2	Test program where the appliance is operated with minimum gas volume (ignition gas volume) after successful ignition
P.3	not available
P.4	not available
P.5	Test program for the safety temperature limit check; appliance heats up by by-passing a regulating shut-down through the flow regulator until the shutoff temperature of 97 °C is achieved.
P.6	Filling test program. The diverter valve moves to the centre position

Table 8.5 Test programs

8.3 Resetting parameter to factory settings

Besides the option to reset individual parameters manually to the factory settings specified in Tables 8.2 and 8.3, you can also reset all parameters simultaneously.

- In the second diagnostic level, under the diagnostic number "d.96" change the value to 1 (see section 8.1.2).

The parameters of all adjustable diagnostic numbers now correspond to the factory settings.

9 Parts replacement

The tasks listed below in this section may be carried out only by a competent person approved at the time by the Health and Safety Executive and in accordance with the Gas Safety (Installation and Use) Regulations 1998.

- Only use genuine spare parts for repairs.
- Make sure the parts are correctly fitted and that their original position and alignment are retained.

9.1 Safety instructions



Danger!

Each time the components are replaced, comply with the safety instructions below for your own safety and to avoid damage to the appliance!

- Put the appliance out of operation.



Caution!

Before starting any maintenance work: Isolate the mains electricity supply by disconnecting the plug at the socket outlet (if there is only an isolating switch remove the fuse from the switch).

- Close the service valve in the gas supply as well as the service valves in the heating flow and return pipe.
- Close the service valve in the cold water supply line (combination boilers only).
- Empty the appliance if you want to replace water-bearing components of the appliance.
- Make sure that no water drops on live components (e.g. switch box etc.).
- Use only new seals and O-rings.
- After completing the work, check for gas leaks and perform a function check (see section 7.6).
- Always check earth continuity, polarity and resistance to earth with a multimeter after any service work and after exchanging any electrical component.

9.2 Replacing burner



Danger!
Before replacing the component, comply with the safety instructions in Section 9.1.

- Dismantle the burner module as described in Section 7.2.1.

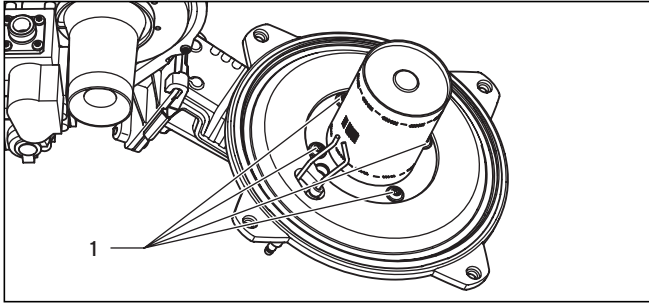

Fig. 9.1 Replacing burner

- Loosen the 4 screws (1) on burner, and remove the burner.
- Mount the new burner with a new seal. Ensuring that the notch in the burner aligns with the burner viewing window.
- Install the burner module as described in Section 7.2.4.
- After completing the work, check for gas leaks and perform a function check (see section 7.6).

9.3 Replacing fan or gas valve



Danger!
Before replacing the component, comply with the safety instructions in section 9.1.

- Turn off the boiler.
- Isolate the electrical supply to the boiler.
- Remove the air intake pipe (Fig. 7.1, Pos. 2).
- Loosen the gas supply pipe on the gas fitting (Fig. 7.2, Pos. 3).

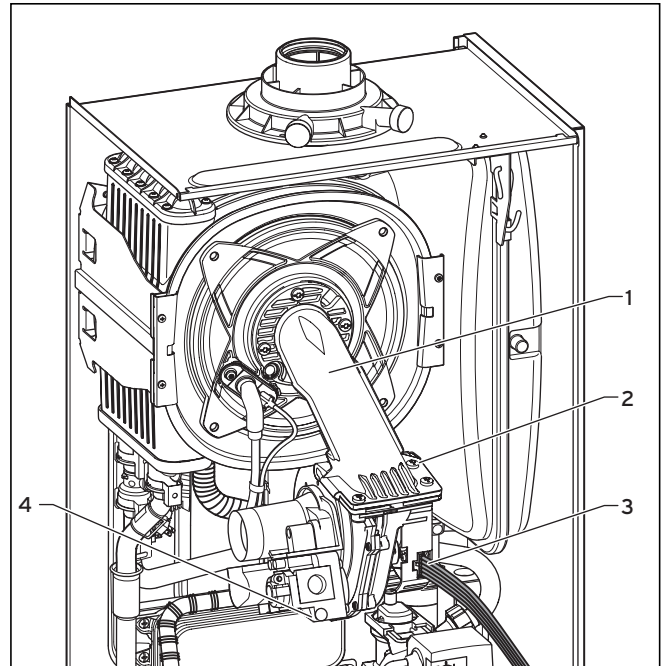

Fig. 9.2 Dismantling fan with gas fitting

- Pull out the plug (4) from the gas valve.
- Pull out the plug (3) from the fan.
- Remove the three screws (2) on the burner module (1).
- Remove the complete "gas valve/fan" unit.

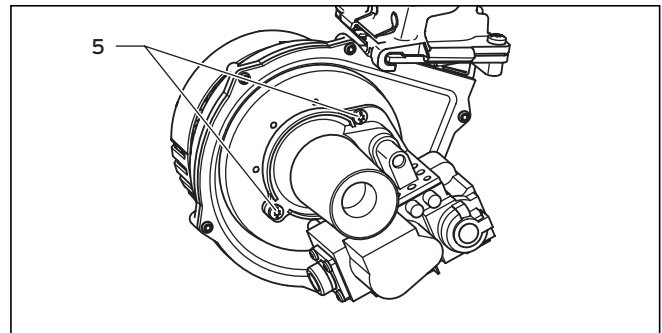

Fig. 9.3 Gas fitting/fan screwed joint

- Remove both fixing screws (5) on the gas valve and remove the fan from the gas valve.
- Replace the defective component.



Caution!
Mount the gas valve and the fan in the same position as before.

- Screw on the fan with the gas valve. Use new seals.
- Install the complete "gas valve/fan" unit in reverse sequence.
- After completing the work, check for gas leaks and perform a function check (see section 7.6).

9 Parts replacement

9.4 Replacing expansion vessel



Danger!

Before replacing the component, comply with the safety instructions in Section 9.1.

- Disconnect the appliance from the mains as described in Section 9.1, and close the service valve in the gas supply pipe.
- Close the flow and return service valves and drain the water from the boiler.

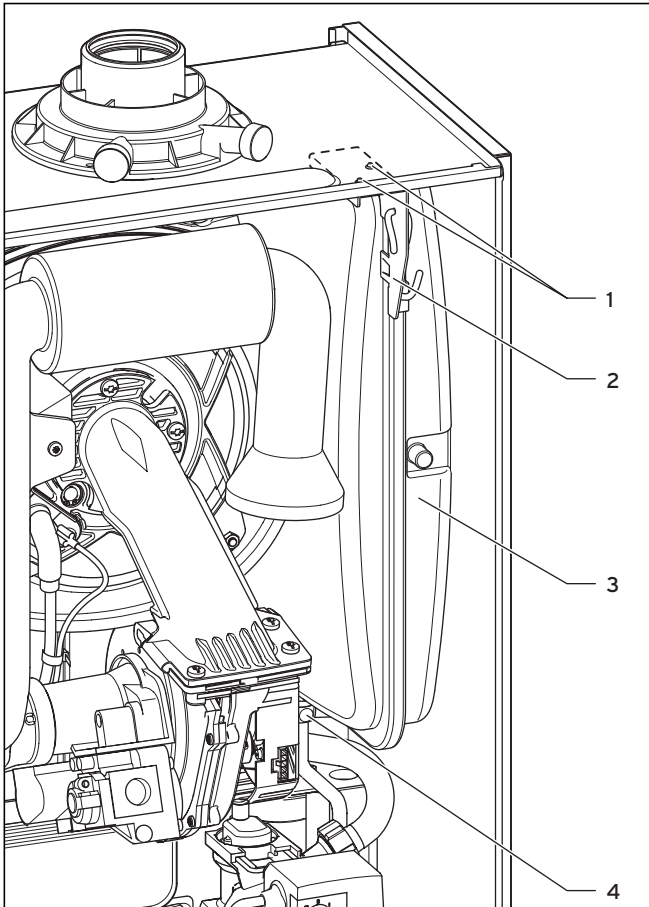

Fig. 9.4 Replacing expansion vessel

- Undo the nut (4) on the water pipe on the lower side of the expansion vessel.
- Remove both screws (1) retaining plate (2) and remove the retaining plate.
- Pull out the expansion vessel (3) forwards.
- Guide the new expansion vessel back into the appliance.
- Re-connect the new expansion vessel using a new seal.
- Refix the retaining plate.
- Check the pressure of the expansion vessel (minimum pressure 0.75 bar).
If necessary, adjust the pressure to the static height of the heating system.
- Fill and vent the boiler.
- After completing the work, check for water leaks and perform a function check (see section 7.6).

9.5 Replacing primary heat exchanger



Danger!

Before replacing the component, comply with the safety instructions in Section 9.1.

- Disconnect the appliance from the mains as described in Section 9.1, and close the service valve in the gas supply pipe.
- Close the flow and return service valves and drain the appliance.
- Remove the burner module as described under 7.2.1.
- Remove the expansion vessel as described under 9.4.
- Pull out the condensate pipe to the siphon from the primary heat exchanger.

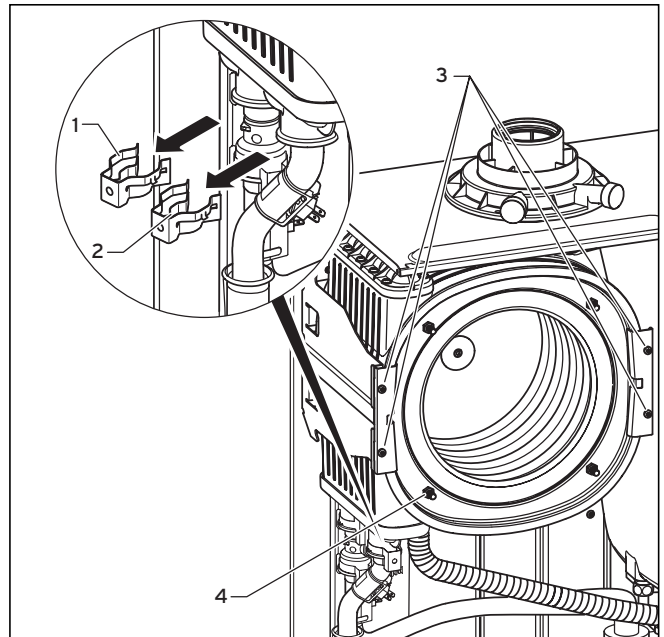

Fig. 9.5 Replacing primary heat exchanger

- Pull out the clamps (1) and (2) and free the return pipe as well as the flow pipe on the primary heat exchanger.
- Remove the four screws (3) on the primary heat exchanger holder.

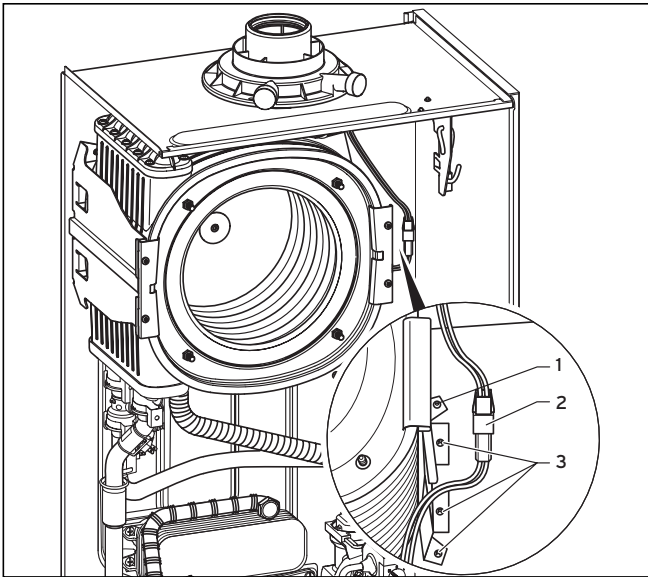

Fig. 9.6 Primary heat exchanger holder

- Disconnect the plug-in connection (2) of the thermal fuse in the primary heat exchanger.
- Remove the three screws (3) on the primary heat exchanger holder.
- Turn the holder to the side around the rivet (1), pull the primary heat exchanger downwards to the right and remove it from the appliance.
- Mount the new primary heat exchanger in reverse order and replace the seals.

Caution!
Risk of damaging the primary heat exchanger!
Neither loosen nor retighten the four screws (Fig. 9.5, Pos. 4).

Caution!
Insert the seal rings for the flow and return pipe on the primary heat exchanger with a suitable lubricant. Insert the flow and return connection in the primary heat exchanger as far as they will go and make sure the clamps are fitted correctly on the flow and return pipe (see Fig. 9.5).

- Fill and vent the boiler as required.
- After completing the work, check for gas and water leaks and perform a function check (see section 7.6).

9.6 Replacing electronics and display

Danger!
Before replacing the component, comply with the safety instructions in Section 9.1.

- Comply with the assembly and installation manuals provided with the spare parts.

Replacing display or electronics

If you are replacing only one of the two components, the parameter adjustment functions automatically. On turning on the appliance, the new component takes over the previously set parameters from the components that are not replaced.

Replacing display and electronics

When replacing both components, after being turned on, the appliance goes to fault and displays the error message "F70".

- In the second diagnostic level, under the diagnostic number "d.93" enter the number of appliance variant according to Table 9.1 (see section 8.1.2).

The electronics is now set to the appliance type and the parameters of all adjustable diagnostics numbers correspond to the factory settings.

Appliance	Device specific number
ecoTEC plus 612	0
ecoTEC plus 615	1
ecoTEC plus 618	2
ecoTEC plus 624	3
ecoTEC plus 630	4
ecoTEC plus 637	5
ecoTEC plus 824	6
ecoTEC plus 831	7
ecoTEC plus 837	8
ecoTEC pro 24	7
ecoTEC pro 28	0

Table 9.1 Device specific numbers

10 Recycling and disposal

11 Vaillant service

10 Recycling and disposal

Both the Vaillant ecoTEC and the associated transport packaging consist primarily of recyclable raw materials. The Vaillant ecoTEC and all accessories and packaging must not be disposed of in the normal household rubbish. Make sure that the old unit and any existing accessories and the transport packaging is handed over to a proper disposal organisation.

11 Vaillant service

To ensure regular servicing, it is strongly recommended that arrangements are made for a Maintenance Agreement. Contact Vaillant Service Solutions (0870 6060 777) for further details.

Appendix



EC declaration of conformity

Name and Address of the manufacturer:

Vaillant GmbH
Berghauser Str. 40
42859 Remscheid

Identification of product:

Condensing wall-hung boiler with its flue ducts

Identification of type:

VU GB 126/3-5, ...156/3-5, ...186/3-5, ...246/3-5,
...306/3-5, ... 376/3-5
VUW GB 246/3-5, ...316/3-5, ...376/3-5
VUW GB 246/3-3, ...286/3-3

The appliance types as described satisfy the essential requirements of the directives which apply to them:

90/396/EEC

"Directive on the approximation of the law of the member states relating to appliances burning gaseous fuels"

Designed and built to CE-type examination certificate:

PIN no: **CE-0085PB0464**

92/42/EEC

"Directive of efficiency relating to boiler burning gaseous fuels"

Designed and built according to European Standards:

EN 483
EN 677
EN 625
EN 60335-1
EN 60529
EN 50165
EN 55014
EN 61000-3-2
EN 61000-3-3

73/23/EEC

"Directive on the harmonization of the laws of Member States relating to electrical equipment designed for use within certain voltage limits"

89/336/EEC

"Directive on the approximation of the law of the member states relating to electromagnetic compatibility"

Any change on the appliance and/or any use not according to the instructions will lead to the invalidation of this Declaration of Conformity

Remscheid, 29.09.2006

(place, date)

 Group Programm Manager
 i. V. H.J. Brecker

 Group Certification Manager
 i. V. A. Nunn

Vaillant 0332006

Vaillant GmbH

Berghauser Str. 40 ■ D-42859 Remscheid ■ main phone no. +49 21 91/18-0 ■ Telefax +49 21 91/18-28 10
 Ltd. company ■ Registered office: Remscheid ■ Registry court: Amtsgericht Wuppertal HRB 11775
 Directors: Dr. Michel Brosset, Claes Göransson ■ Chairman of the Supervisory Board: Gert Krüger
 Commerzbank Remscheid (code 340 400 49) account no. 621 833 300 ■ USt-Ident-Nr. DE 811142240

PDF approval project/prepare 2004/Vaillant/PR023_mil/Euro111/Declaration of conformity/Wall_CE_0085PB0464_GB_mil_2.0oct10.12.2011rev

Installation, Commissioning and Service Record



Please affix the label from the rear cover of the control box over this area.

PEEL OFF

COMMISSIONING CHECKLIST GAS BOILER SYSTEM

This Commissioning Checklist is to be completed in full by the competent person who commissioned the boiler as a means of demonstrating compliance with the appropriate Building Regulations and then handed to the customer to keep for future reference.

Failure to install and commission this equipment to the manufacturer's instructions may invalidate the warranty but does not affect statutory rights.

Customer Name _____ Telephone Number _____
 Address _____
 Commissioned by (print name) _____ Engineer ID Number _____
 Company Name _____ Telephone Number _____
 Company Address _____ Commissioning Date _____

To be completed by the customer on receipt of a Building Regulations Compliance Certificate*:

Building Regulations Notification Number (if applicable) _____

CONTROLS Tick the appropriate boxes

Time and Temperature Control to Heating	Room Thermostat and Programmer/Timer <input type="checkbox"/>	Programmable Room Thermostat <input type="checkbox"/>	Load/Weather Compensation <input type="checkbox"/>	Optimum Start Control <input type="checkbox"/>
Time and Temperature Control to Hot Water	Cylinder Thermostat and Programmer/Timer <input type="checkbox"/>		Combination Boiler <input type="checkbox"/>	
Heating Zone Valves	Fitted <input type="checkbox"/>		Not Required <input type="checkbox"/>	
Hot Water Zone Valves	Fitted <input type="checkbox"/>		Not Required <input type="checkbox"/>	
Thermostatic Radiator Valves	Fitted <input type="checkbox"/>		Not Required <input type="checkbox"/>	
Automatic Bypass to System	Fitted <input type="checkbox"/>		Not Required <input type="checkbox"/>	
Boiler Interlock				Provided <input type="checkbox"/>

ALL SYSTEMS

The system has been flushed and cleaned in accordance with BS7593 and boiler manufacturer's instructions Yes

What system cleaner was used? _____

What inhibitor was used? _____ Quantity litres

CENTRAL HEATING MODE Measure and Record:

Gas Rate m³/hr OR ft³/hr
 Burner Operating Pressure (if applicable) mbar OR Gas Inlet Pressure mbar
 Central Heating Flow Temperature °C
 Central Heating Return Temperature °C

COMBINATION BOILERS ONLY

Is the installation in a hard water area (above 200ppm)? Yes No

If yes, has a water scale reducer been fitted? Yes No

What type of scale reducer has been fitted? _____

DOMESTIC HOT WATER MODE Measure and Record:

Gas Rate m³/hr OR ft³/hr
 Burner Operating Pressure (at maximum rate) mbar OR Gas Inlet Pressure (at maximum rate) mbar
 Cold Water Inlet Temperature °C
 Hot water has been checked at all outlets Yes Temperature °C
 Water Flow Rate l/min

CONDENSING BOILERS ONLY

The condensate drain has been installed in accordance with the manufacturer's instructions and/or BS5546/BS6798 Yes

ALL INSTALLATIONS

If required by the manufacturer, record the following CO₂ % OR CO ppm OR CO/CO₂ Ratio

The heating and hot water system complies with the appropriate Building Regulations Yes

The boiler and associated products have been installed and commissioned in accordance with the manufacturer's instructions Yes

The operation of the boiler and system controls have been demonstrated to and understood by the customer Yes

The manufacturer's literature, including Benchmark Checklist and Service Record, has been explained and left with the customer Yes

Commissioning Engineer's Signature _____

Customer's Signature _____

(To confirm satisfactory demonstration and receipt of manufacturer's literature)

*All installations in England and Wales must be notified to Local Authority Building Control (LABC) either directly or through a Competent Persons Scheme. A Building Regulations Compliance Certificate will then be issued to the customer.



SERVICE INTERVAL RECORD

It is recommended that your heating system is serviced regularly
and that you complete the appropriate Service Interval Record Below .

Service Provider. Before completing the appropriate Service Interval Record below, please ensure you have carried out the service as described in the boiler manufacturer's instructions. Always use the manufacturer's specified spare part when replacing all controls.

SERVICE 1 Date

Energy Efficiency Checklist completed? Yes No

Engineer Name _____

Company Name _____

Telephone Number _____

Engineer ID Number _____

Comments _____

Signature _____

SERVICE 2 Date

Energy Efficiency Checklist completed? Yes No

Engineer Name _____

Company Name _____

Telephone Number _____

Engineer ID Number _____

Comments _____

Signature _____

SERVICE 3 Date

Energy Efficiency Checklist completed? Yes No

Engineer Name _____

Company Name _____

Telephone Number _____

Engineer ID Number _____

Comments _____

Signature _____

SERVICE 4 Date

Energy Efficiency Checklist completed? Yes No

Engineer Name _____

Company Name _____

Telephone Number _____

Engineer ID Number _____

Comments _____

Signature _____

SERVICE 5 Date

Energy Efficiency Checklist completed? Yes No

Engineer Name _____

Company Name _____

Telephone Number _____

Engineer ID Number _____

Comments _____

Signature _____

SERVICE 6 Date

Energy Efficiency Checklist completed? Yes No

Engineer Name _____

Company Name _____

Telephone Number _____

Engineer ID Number _____

Comments _____

Signature _____

SERVICE 7 Date

Energy Efficiency Checklist completed? Yes No

Engineer Name _____

Company Name _____

Telephone Number _____

Engineer ID Number _____

Comments _____

Signature _____

SERVICE 8 Date

Energy Efficiency Checklist completed? Yes No

Engineer Name _____

Company Name _____

Telephone Number _____

Engineer ID Number _____

Comments _____

Signature _____

SERVICE 9 Date

Energy Efficiency Checklist completed? Yes No

Engineer Name _____

Company Name _____

Telephone Number _____

Engineer ID Number _____

Comments _____

Signature _____

SERVICE 10 Date

Energy Efficiency Checklist completed? Yes No

Engineer Name _____

Company Name _____

Telephone Number _____

Engineer ID Number _____

Comments _____

Signature _____

Vaillant Ltd

Vaillant House ■ Medway City Estate ■ Trident Close ■ Rochester ■ Kent ME2 4EZ
Telephone 01634 292300 ■ Fax 01634 290166 ■ www.vaillant.co.uk ■ info@vaillant.co.uk