

The Greenstar Highflow CDi gas-fired condensing combi boiler series

Technical and specification information



NEW
PRODUCT

 **WORCESTER**
Bosch Group



Worcester and you. Making a difference.

Working together for many years, heating professionals and Worcester have been making a real difference in hundreds of thousands of homes across the UK. We are recognised as a market leader in high efficiency, condensing boiler technology and are also committed to providing renewable energy solutions.

As part of the Bosch Group, our products are designed and manufactured to provide the high levels of quality and reliability which are synonymous with the Bosch name throughout the world.

We're a leading British company, employing approximately 2,000 people at our headquarters and manufacturing plants in Worcester and at Clay Cross in Derbyshire, including a nationwide network of over 300 Service Engineers and over 80 technically-trained Field Sales Managers.

As part of Europe's largest supplier of heating products, Worcester, Bosch Group has the UK-based resources and support capability to offer you the value-added solutions we feel you deserve.



BOSCH
Invented for life



Worcester, Bosch Group headquarters

“At Worcester we recognise the vital role you, our customer, has in the specification and installation of ‘A’ rated, energy efficient appliances in homes across the UK. We will continue to invest in our products, people, facilities and added value services such as training, to give you the support you require in providing a total solution for your customers’ comfort.”

Richard Soper,
Managing Director, Worcester, Bosch Group

Contents

| | Page |
|---|-------------|
| The Greenstar Highflow CDi gas-fired condensing combi boiler series | 4 - 7 |
| Optional plug-in controls | 8 - 9 |
| Technical data | 10 |
| The inside story | 11 |
| Installing the Greenstar Highflow CDi boiler series | 12 - 19 |
| Greenstar Highflow CDi series horizontal fluing options | 20 - 21 |
| Greenstar Highflow CDi series vertical fluing options | 22 - 23 |
| Plume management system options | 24 - 27 |
| Installation requirements | 28 - 30 |
| The Greenstar Highflow CDi series accessories | 31 - 32 |
| After-sales | 33 |
| Worcester training | 34 - 35 |



The Greenstar Highflow CDi condensing combi boiler series



The Greenstar Highflow CDi series is part of a market leading range of energy-saving condensing floor standing gas-fired combi boilers.

Higher efficiency therefore highly cost effective

All of the new Greenstar Highflow CDi condensing combi boilers are SEDBUK A rated. This means they have an average annual efficiency of 90.8%, standard efficiency boilers achieve around 78% efficiency. Therefore by upgrading to a Greenstar Highflow CDi boiler, consumers can reduce their gas bills as well as their carbon footprint.

The Greenstar Highflow CDi condensing boiler series delivers this energy-saving performance by recycling exhaust gases to extract the latent heat – a highly efficient use of energy which also significantly reduces carbon dioxide emissions into the atmosphere.

To all these major benefits you can add yet more: renowned Worcester quality and reliability; outputs and flow rates to comfortably satisfy the heating and hot water demands of the larger household and all-round value for money.

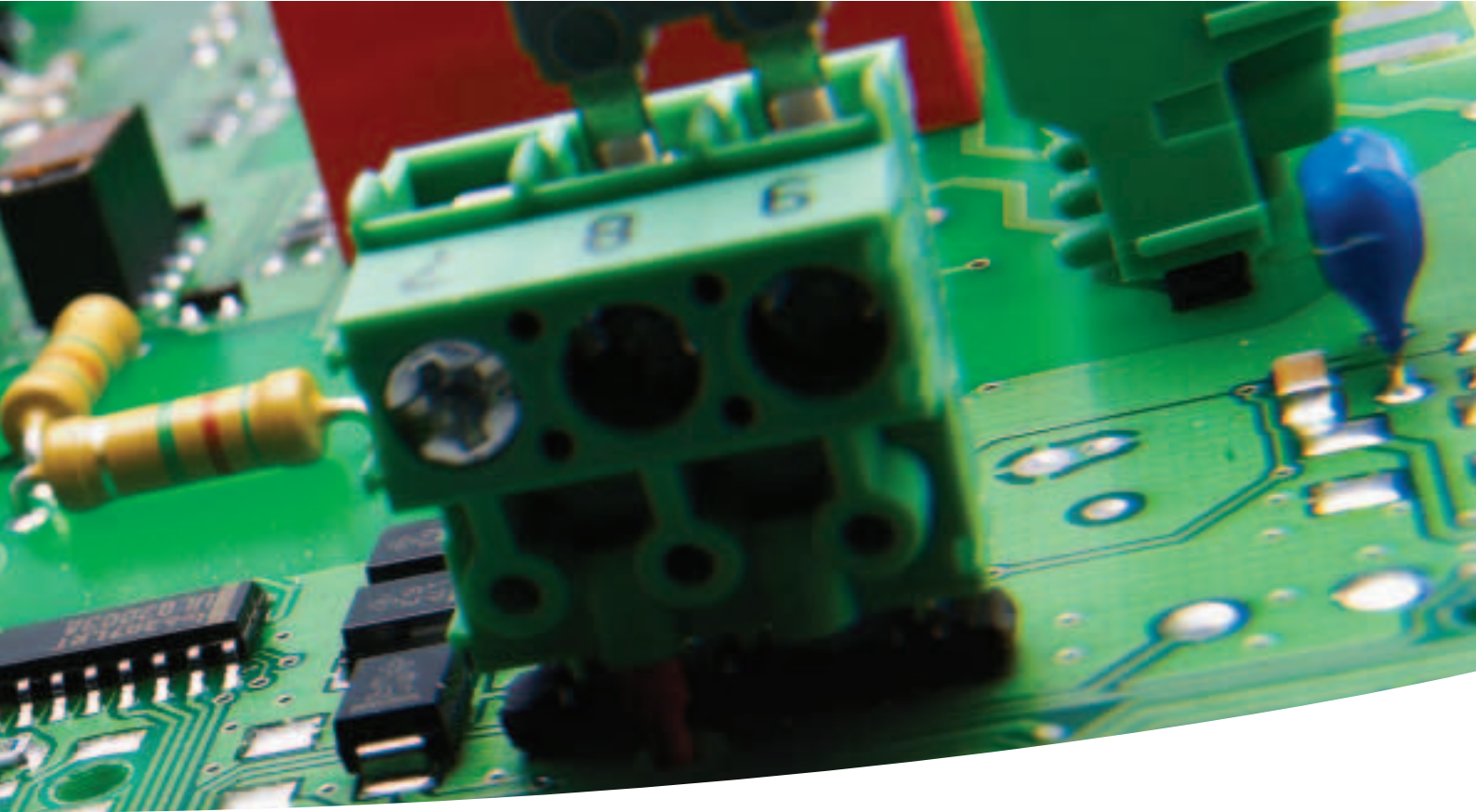

The Greenstar Highflow CDI combi series at a glance

| | Greenstar Highflow 440CDi | Greenstar Highflow 550CDi |
|--------------------------------|----------------------------------|----------------------------------|
| Output kW | 7.4kW | 9.7kW |
| Min to DHW | | |
| Max | 29.5kW | 41.1kW |
| Flow rate at 35°C Δ T | 20l/min* | 25l/min* |
| CH temperature control | • | • |
| DHW temperature control | • | • |
| Natural gas | • | • |
| LPG boiler | • | • |
| Electronic ignition | • | • |
| SEDBUK band | A (90.8%) | A (90.8%) |

*Provided adequate mains water pressure and flow is available – see page 29 for further details



| Features | Benefits |
|---|---|
| 20 & 25 litre/minute flow rate NEW | Suitable for larger family homes |
| Built-in condensate pump – 4.5m head NEW | Increases siting possibilities |
| Earth bonding strip | Labour and money saving |
| Roll-in boiler | Minimises risk of damaging floors |
| Built-in filling link | Labour and money saving |
| Temperature control for CH + DHW | Consumer-friendly and energy saving |
| Multi-directional Condensfit II fluing – compatible with plume management | Siting flexibility |
| Floor mounted pre-plumbing jig | Allows pre-filling of system and no pipe fabrication required |
| Electronic ignition | Energy saving |
| Built-in frost protection | Money saving, economical protection |
| Pump seizure protection | Prevents call-backs |
| Fault finding diagnostics | Time saving |
| Anti-cycle device | Energy saving |
| No ventilation grilles required in compartments | Labour and money saving |
| Optional plug-in twin channel programmer | No electrician required |

The Greenstar Highflow CDi condensing combi boiler series

A condensing boiler is more efficient due to its ability to extract more heat from the flue gases normally lost to the environment through the flue system.

Greenstar Highflow CDi combis use a proven aluminium-silicon heat cell with an extra large surface area.

As the flue gases pass through the heat exchanger this extra surface area cools the flue gases to around 55°C at which point the latent heat within is released. This is heat that would normally be lost to the atmosphere.

It is this ability to extract as much heat as possible from the gas it burns that gives Greenstar Highflow CDi combis an exceptionally high level of operating efficiency.

This higher efficiency is recognised within section L of the Building Regulations, subsequently achieving a higher SAP or NHER rating.

The separate plated DHW heat exchanger combined with the thermal store ensures that hot water is delivered instantly to the outlet being operated.

Modulating central heating and hot water outputs combined with separate consumer controls, also mean that comfortable temperature levels for both can be set independently of each other.

Greenstar Highflow CDi combis are supplied as standard suitable for sealed primary water systems. The appliance contains a 12 litre expansion vessel, 3bar pressure relief valve, pressure gauge and an automatic air vent. The appliance cannot be used on an open vent system.

Fluing

Greenstar Highflow CDi combis are available as a multi-directional room-sealed fanned flue appliance.

Gas

The Greenstar Highflow CDi is manufactured in both natural gas and Liquid Petroleum Gas (LPG) variants.

The advantages of a combi boiler

A combi (or combination boiler) is a compact and highly efficient unit giving all the heating and hot water you need, with significant savings on running and installation costs.

Unlike a conventional heating and hot water system, a combi boiler system does not store domestic hot water. It heats water directly from the cold water mains – as you use it. There's no hot water cylinder, no tank in the loft (and so less risk of freezing and flooding), and none of the connecting pipework.

So you not only save space, but also reduce hot water costs – which can account for up to 60% of a typical domestic fuel bill.

A combi also supplies hot water at mains pressure, giving you powerful showering without the need for a pump. And as, on average, a shower uses considerably less water than a typical bath, the savings on hot water costs and water consumption can be significant.

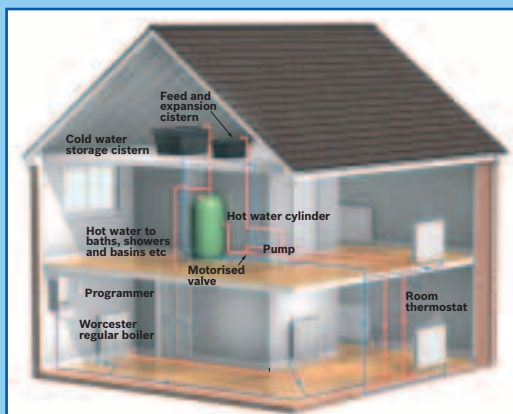

Regular boiler layout

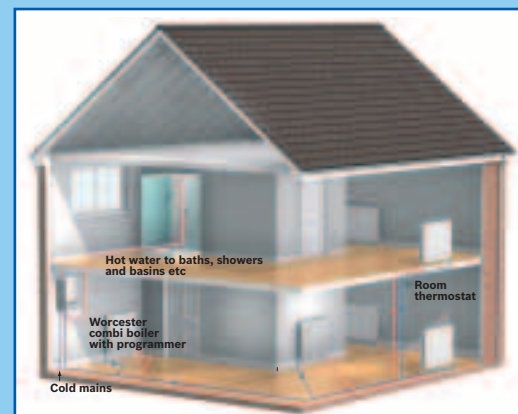

Combi boiler layout

Operation

Hot water mode

With the appliance in a standby condition, i.e. thermal store or heatbank at temperature set by the hot water thermostat, a demand for hot water will cause the flow turbine to energise the pump and circulate primary hot water around the boiler and the plated water to water heat exchanger. The burner will ramp-up at its maximum setting and modulate accordingly to maintain the temperature of the heatbank.

When hot water is no longer required the appliance will continue to operate until the heatbank has returned to the required temperature.

Priority is always given to the production of domestic hot water. Should the central heating be in operation when a hot water demand is made, the supply to the radiators will be temporarily interrupted.

Central heating mode

On a demand for central heating the pump will energise, the diverter valve will open and primary water will circulate around the heating system. The burner will light at the minimum setting and ramp upwards to meet the system demand. The radiators will heat up to the temperature set by the fascia mounted heating temperature controller (assuming there are no TRVs on the radiators).

Application of Greenstar Highflow CDi combis

- Worcester Greenstar Highflow CDi combis deliver domestic hot water at a flow rate of 20 litres/min (4.4gpm) & 25 litres/min (5.5gpm), making the appliances ideally suited for use in medium to large sized family homes, incorporating up to three bathrooms
- As the Worcester Greenstar Highflow CDi combis deliver hot water at mains pressure, they are ideally suited to providing a powerful shower
- Worcester Greenstar Highflow CDi combis can be sited where space and water storage is a problem
- Worcester Greenstar Highflow CDi combis may be used to provide domestic hot water only, with radiators being added at a later date
- The fluing options available with Greenstar Highflow CDi combis, both horizontal and vertical, offer excellent scope for siting the appliance, particularly in kitchens, airing cupboards, etc

- Worcester Greenstar Highflow CDi combis can be sited underneath a worktop as servicing can be undertaken from the front. A removable section of worktop is recommended should you require top access for maintenance work

Hot water performance

Greenstar Highflow 440CDi

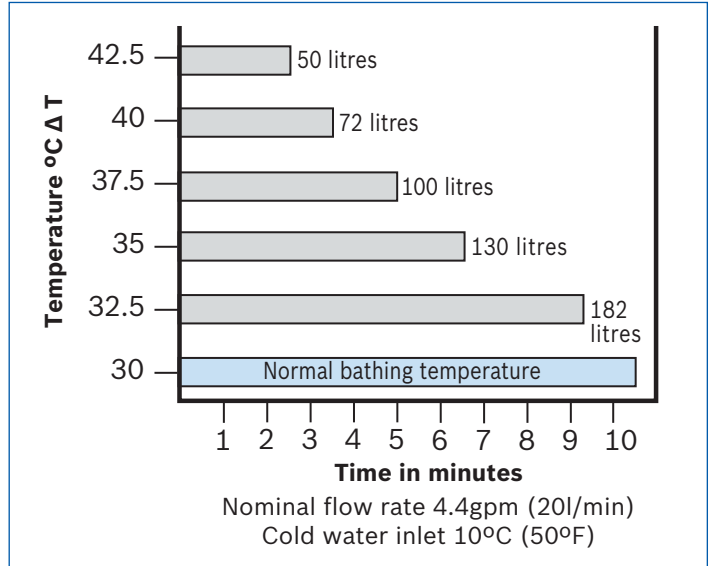

Greenstar Highflow 550CDi

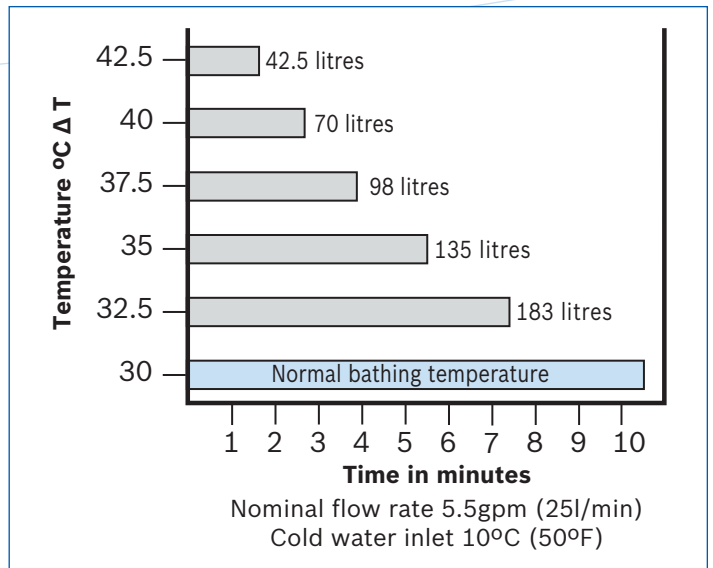

Fluing

Greenstar Highflow CDi combis feature 2 different sizes of multi-directional RSF flue systems, 100mm or 125mm dia.

The flue can be run horizontally or vertically with additional 90° or 45° in-line bends allowing changes of route or direction, providing an extremely flexible and versatile fluing system enabling the appliance to be sited virtually anywhere. More details are shown on page 20.

Optional plug-in controls

Greenstar Highflow CDi floor standing condensing combi boilers are available with a range of easy-to-use controls. These fascia-mounted controls offer simple plug-in connection to the boiler circuit board.

Mechanical timers

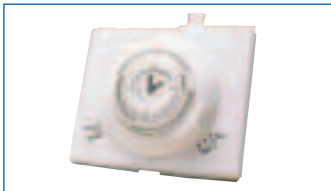

MT10 mechanical timer

The simplest Worcester control device – an easy-to-use analogue clock for setting heating time periods. It plugs into the boiler fascia via a pre-prepared plug and socket.



MT10RF mechanical RF thermostat

Has an analogue display for setting night and day time periods and temperature. The receiver plugs into the boiler and is activated remotely by the RF (radio frequency) controller, which requires no wiring. So installation is clean and simple – no disturbance to floorboards or carpets. Nor is there any need for a separate room thermostat.

These mechanical timers do not control domestic hot water pre-heat. If this function is required please select a digital programmer. Alternatively, an additional single channel timer for hot water control, could be wired in remotely.

Digital and wireless programmers and room thermostats



DT20RF digital RF thermostat with twin channel programmer

A wall-mounted RF room thermostat with digital display, combined with a twin channel digital timer in the boiler fascia. The fascia mounted programmer benefits from automatic time and date setup, automatic summer/wintertime changeover and a backlight for use in low light conditions.



DT20 twin channel digital programmer

A versatile, easy-to-learn, 7 day, digital programmer offering up to 3 on/off settings per day. The programmer has a host of innovative features including automatic setup, which sets the correct time and date at power-up, automatic summer/wintertime changeover and a green backlight for use in low light conditions.

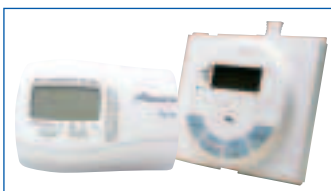

DT10RF digistat

A familiar wall-mounted 24 hour programmable RF digital thermostat combined with a fascia mounted single channel programmer to time the hot water combi preheat functions. The programmer includes a built-in receiver for the room thermostat and all of the functionality of the DT20.

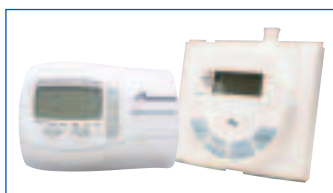

DT10RF optimiser

A seven day digital programmable RF thermostat with a seven day programmer/receiver in the boiler fascia for hot water. The transmitter is the tried and tested Optimiser as available with other Worcester boilers. The optimum start feature, where the thermostat delays the firing of the boiler until necessary, is a useful energy-saving option.



TD200 text display*

A seven day programmer with easy-to-use text display with automatic time and date setup, automatic summer/winter time changeover and a backlight for use in low light conditions. Three on/off periods can be set per day. The TD200 can be fascia mounted or hard wired outside the boiler using the optional wall mounting socket. The TD200 features an easy-to-use full text display providing more information than standard digital controls. A hard wired room thermostat is available to provide optimum start functionality.



RT10 room thermostat*

A hard wired optimising room temperature controller with digital display for use with the TD200. The display shows current and desired temperature and an advance button allows the user to move to the next heating switch point.

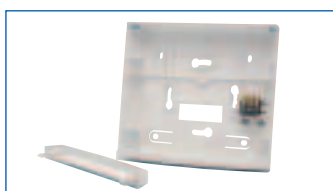

TD200 wall mounting socket*

A Worcester branded wall mounting socket which allows the TD200 to be hard wired away from the boiler.

**All three of the above are classed as an Intelligent Combi package.*

Increased SAP ratings

As well as the Greenstar Highflow CDi appliances achieving very high SAP ratings for dwellings, the addition of the optimising temperature controller further increases these ratings as well as being part of the recommended best practice, as covered by the CHeSS design standard.



TD200 text display

Technical data – Greenstar Highflow CDi series

| Model | Greenstar Highflow 440CDi | Greenstar Highflow 550CDi |
|---|---------------------------------|----------------------------------|
| Height (mm) | 850 | 850 |
| Width (mm) | 600 | 600 |
| Depth (mm) | 600 | 600 |
| Weight – dry (kg) | 112 | 112 |
| SEDBUK value % / band – natural gas | 90.8%/Band A | 91%/Band A |
| SEDBUK value % / band – LPG | 92.2%/Band A | 92.2%/Band A |
| Heating flow / return connections | 22mm compression | 22mm compression |
| Hot / cold water connections | 22mm compression | 22mm compression |
| Pressure relief valve (mm dia.) | 15 | 15 |
| Condensate connection | 22mm plastic pipe | 22mm plastic pipe |
| Gas connection | 22mm compression | 22mm compression |
| Primary water content (litres) | 51 | 51 |
| Min. domestic inlet pressure for max. DHW flow rate (bar) | 1.5 | 1.7 |
| Min. domestic inlet pressure to operate the appliance (bar) | 0.5 | 0.5 |
| Max. domestic inlet pressure (bar) | 10 | 10 |
| DHW flow rate @ 35°CΔT (l/min) | 20 | 25 |
| Output to central heating kW (Btu) | 7.4 - 29.2 (25,590 - 99,630) | 9.7 - 30.6 (33,096 - 104,407) |
| Floor mounted pre-plumbing jig | • | • |
| Filling link | • | • |
| Plug-in timer | • (optional) | • (optional) |
| Condensate disposal pump | • | • |
| Fault diagnostic display | Digital | Digital |
| Max. vertical flue (mm) (100mm dia.) inc. terminal | 6,400 | 6,400 |
| Max. vertical flue (mm) (125mm dia.) inc. terminal | 15,000 | 15,000 |
| Max. horizontal flue (mm) (100mm dia.) | 4,000 | 4,000 |
| Max. horizontal flue (mm) (125mm dia.) | 13,000 | 13,000 |
| NOx classification | Class 5 | Class 5 |

The Greenstar Highflow CDi condensing combi boiler series – inside story

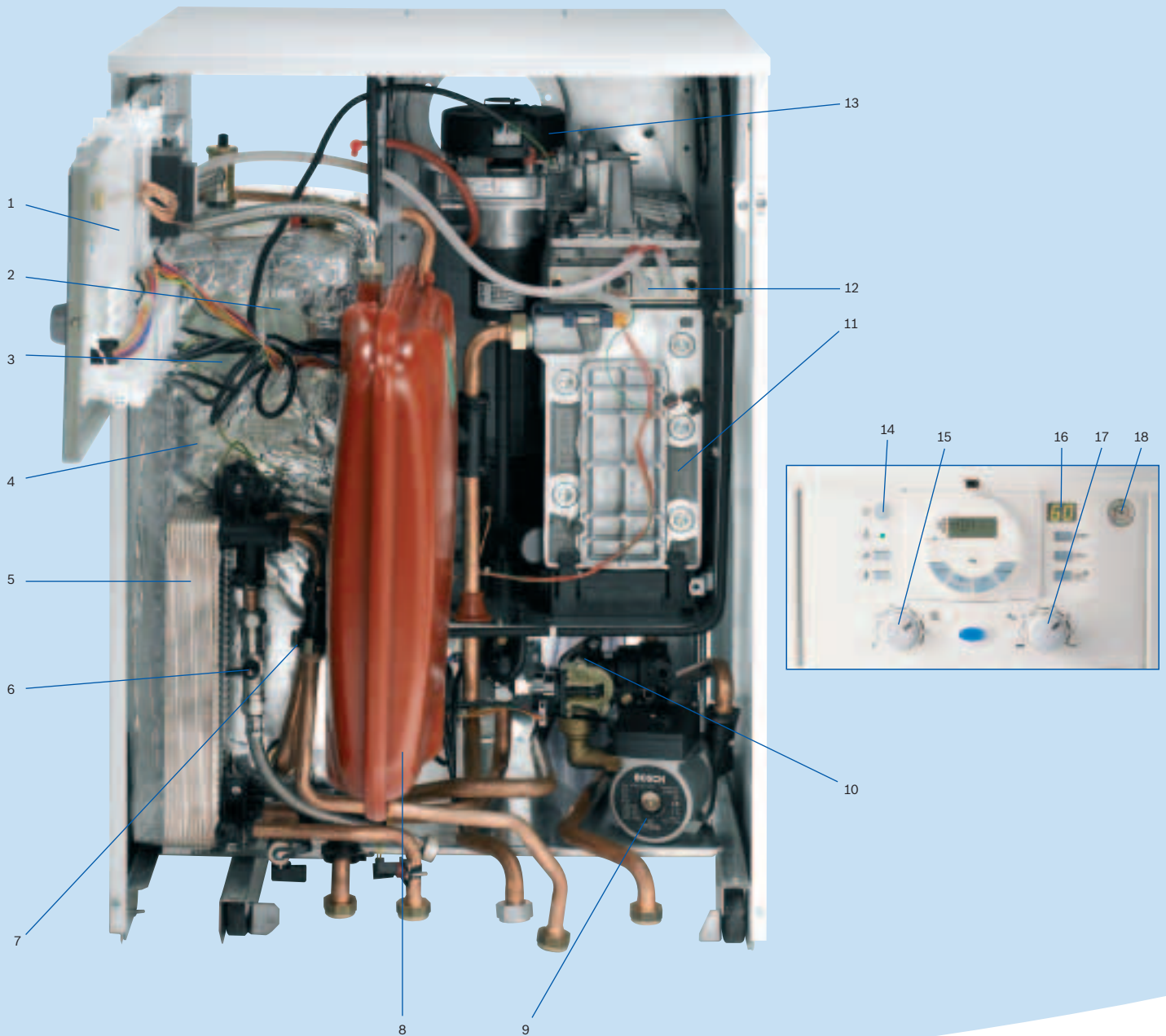

Key to components

- | | |
|---------------------------------|--|
| 1. Control panel | 10. Gas valve |
| 2. Tank over heat thermostat | 11. Heat cell |
| 3. Tank temperature sensor | 12. Gas burner/spark electrodes |
| 4. Heat store | 13. Combustion air modulating fan |
| 5. Plate DHW heat exchanger | 14. On/off button |
| 6. Filling loop isolation valve | 15. Central heating temperature control |
| 7. Water flow sensor turbine | 16. Digital display |
| 8. Expansion vessel | 17. Domestic hot water temperature control |
| 9. Circulating pump | 18. Pressure gauge |

Installing the Greenstar Highflow CDi series

Siting of appliance

General

The appliance is not suitable for external installation. The floor on which the boiler is to be mounted should be capable of supporting an overall weight of approximately 160kg.

Clearances

The following clearances should be allowed for installation and servicing.

Installation clearances

The minimum space required to install the boiler only.

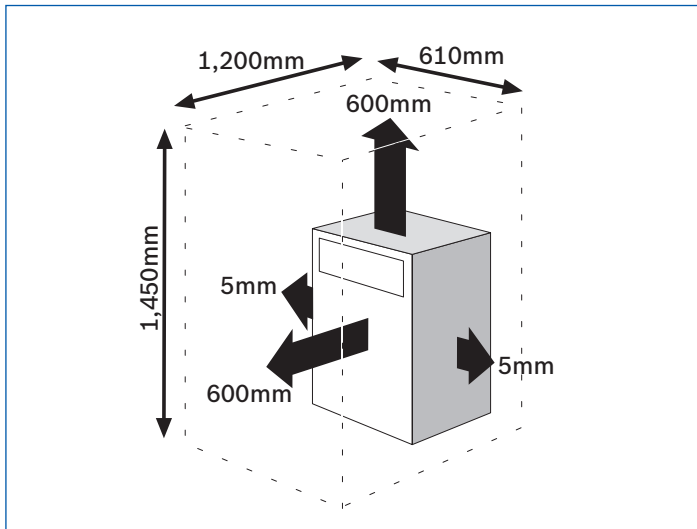

Service clearances

The minimum space required to service the boiler only.

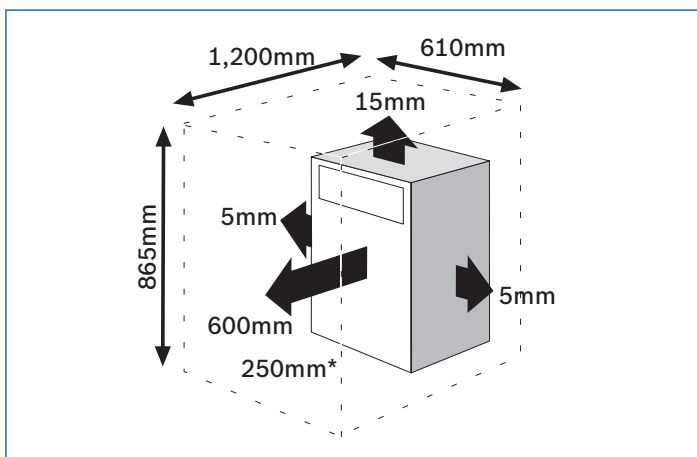

*Space required for unvented areas with a removable door or panel

Site preparation/portability

Greenstar Highflow CDi appliances are supplied with a floor mounted pre-plumbing jig. The jig enables all gas and water services to be pre-plumbed and tested prior to fitting the boiler.

For ease of installation the appliance has a roll-in boiler tray which allows it to be rolled into place once the connections have been made.

Pipework connections and casing dimensions

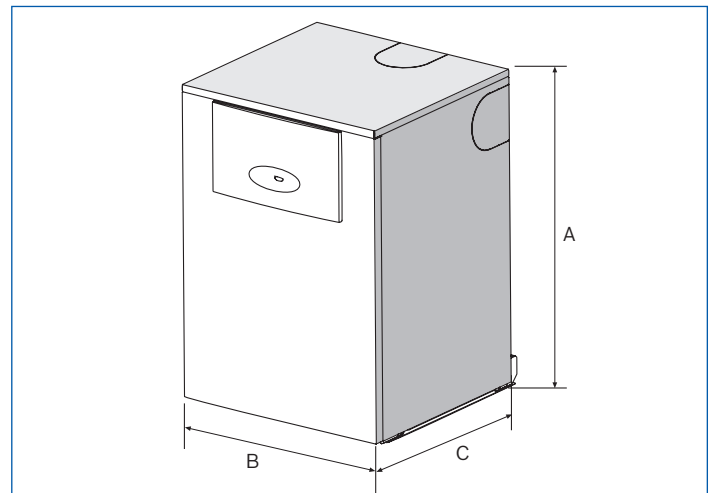

| Cabinet dimensions (mm) | |
|-------------------------|-----|
| A | 850 |
| B | 600 |
| C | 600 |

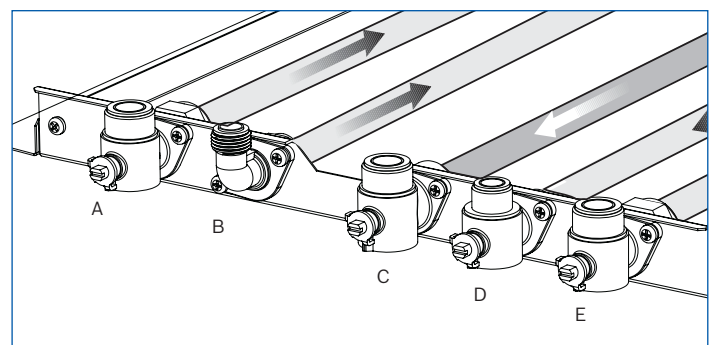

| Pipework connections | | |
|----------------------|-----------------|------|
| A | CH flow | 22mm |
| B | DHW flow | 22mm |
| C | Gas inlet | 22mm |
| D | Cold main inlet | 22mm |
| E | CH return | 22mm |

Condensate disposal

All condensing boilers generate condensate discharge which needs to be piped away from the appliance using a plastic pipe.

The amount of condensate generated depends on the efficiency and operating status of the appliance. Depending on operating temperatures, the appliance will condense in both heating and hot water modes and may generate up to 2.7 litres of condensate per hour for the 440CDi and 3.7 litres per hour for the 550CDi.

Condensate termination and route

Greenstar Highflow CDi combis incorporate a condensate pump which allows condensate to be plumbed above the boiler, allowing more flexible siting possibilities.

Condensate connection

The condensate pump fills up and periodically discharges through the flexible condensate pipe between 200mm and 4,500mm from floor level. After this point the condensate continues down the 22mm rigid pipework to the outlet using gravity.

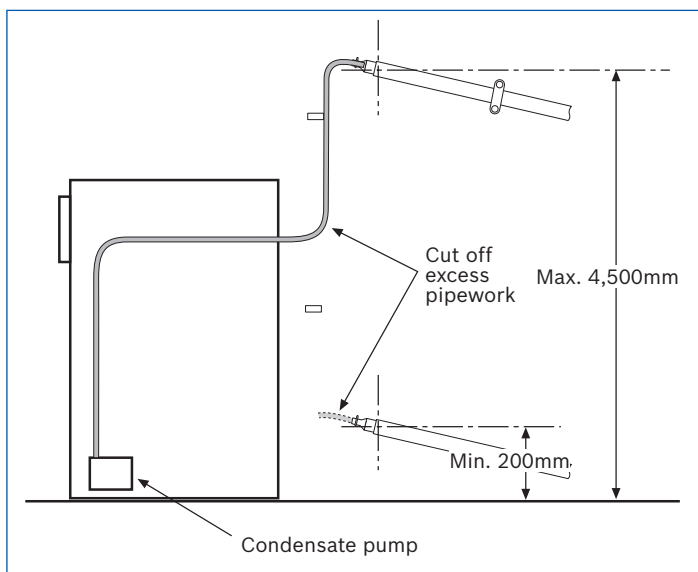

- The flexible plastic pipe can be reduced in length to suit the installation circumstances. The pipework must follow one of the options shown on the next page.

Never terminate or discharge into any open source, including: sink, bath, shower, bidet, toilet etc.

Note: any external condensate pipework should be protected with weather resistant insulation to help prevent freezing.

The condensate connection on Worcester appliances is in 22mm polypropylene. The pipe should be extended and run away from the appliance with a constant fall of 3° or at least 50mm in every metre away from the boiler.

The condensate pipe can terminate into any one of four areas (see next page).

Whilst all of the methods are acceptable it is best practise to terminate the condensate pipe via an internal waste system. This will eliminate the need for any external condensate pipe runs which can be susceptible to freezing in extreme weather. Best practise is not to run external condensate pipe any further than 3m. If it is necessary to run more than 3m externally increase pipe size to 32mm.

Condensate termination and route

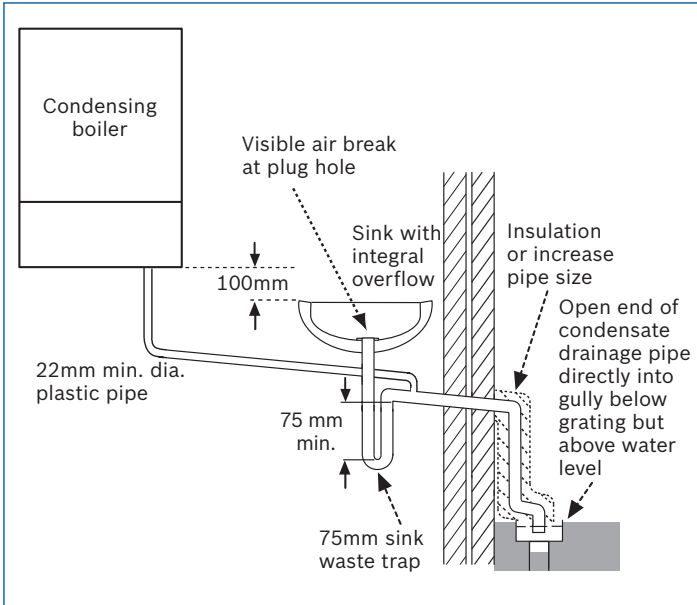

Internal sink/washing machine drain

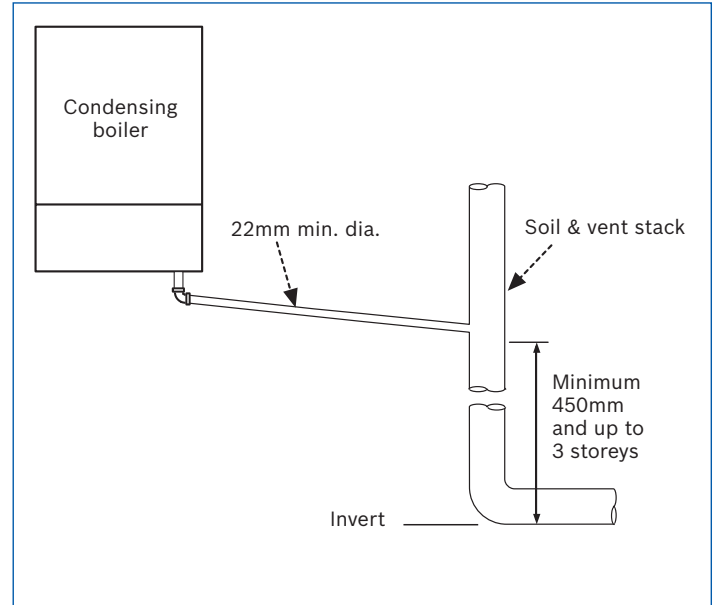

Soil and vent stack

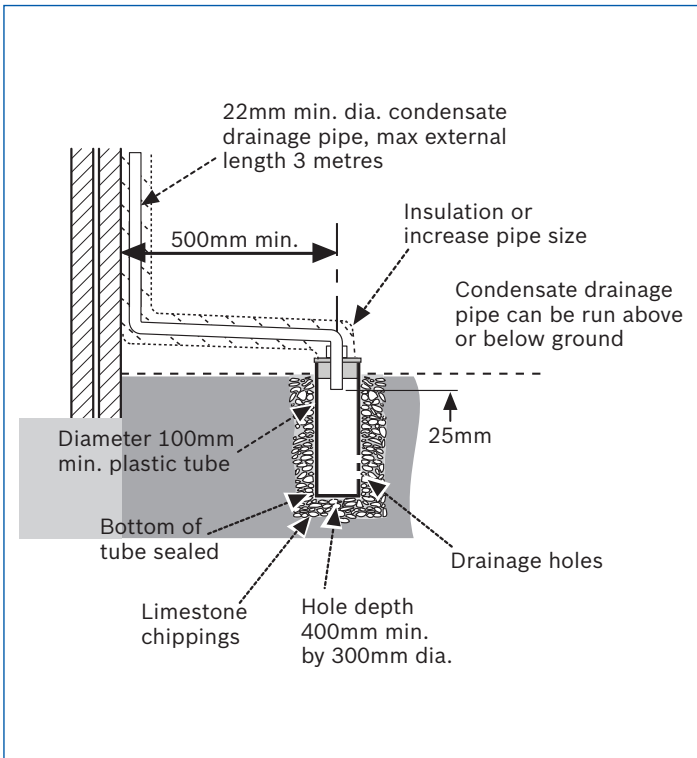

External condensate absorption point (unsuitable for clay soil types)

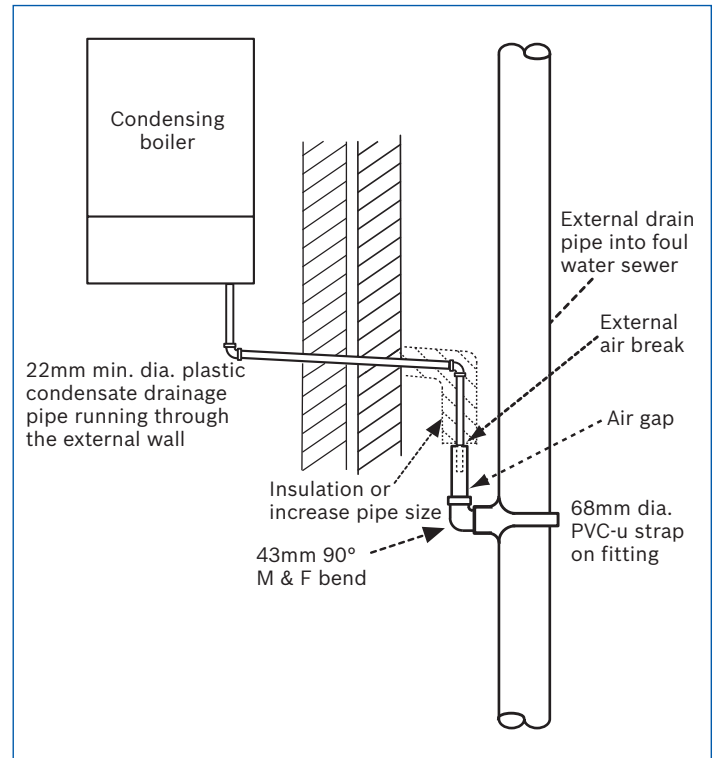

External air break when using a foul water down pipe

External condensate pipework

The Worcester Greenstar Highflow CDi appliances have a condensate pump rather than a syphonic condensate trap. Rather than the condensate constantly dripping into the discharge pipe, the condensate is collected in the pump which releases it in 100ml quantities. This will help prevent freezing occurring.

Wherever possible the condensate discharge pipework should be routed and terminated internally. Should this not be possible, and the only available route is external, the following conditions should be observed:

- The pipework length should be kept to a minimum and the route as vertical as possible
- Where pipework could be subjected to extreme cold or wind chill, a weather proof insulation should be used.

Alternatively, the condensate pipework could be increased to a minimum 32mm.

Compartment installation

The appliance may be installed in any room, although particular attention is drawn to the requirements of the IEE regulations applicable and in Scotland the electrical provisions with respect to installation in a room containing a bath or shower.

Air supply

1. The room in which the appliance is installed does not require a dedicated air vent.
2. If the appliance is installed in a cupboard or compartment with dimensions that allow the following minimum clearances, then no ventilation is required:

| Compartment installation | |
|--------------------------|-----------------------------|
| Position of appliance | Min. unventilated clearance |
| In front | 75mm* |
| Right side | 100mm |
| Left side | 100mm |
| Above flue elbow/casing | 50mm |

*75mm from an opening door. 600mm is required for servicing

Boiler location and clearances

This boiler is only suitable for installing internally within a property at a suitable location on a fixed, rigid non-combustible surface of at least the same size as the boiler and capable of supporting the boiler weight.

Compartments: Follow the requirements of BS 6798 and BS 5440 Part 2 and note:

- Minimum clearances must be maintained
- An access door is required to install, service and maintain the boiler and any ancillary equipment
- If fitting the boiler into an airing cupboard use a non-combustible perforated material (maximum hole sizes of 13mm) to separate the boiler from the airing space.

Unvented compartment clearances

The diagram shows the minimum space required to install and service the boiler inside an unvented compartment.

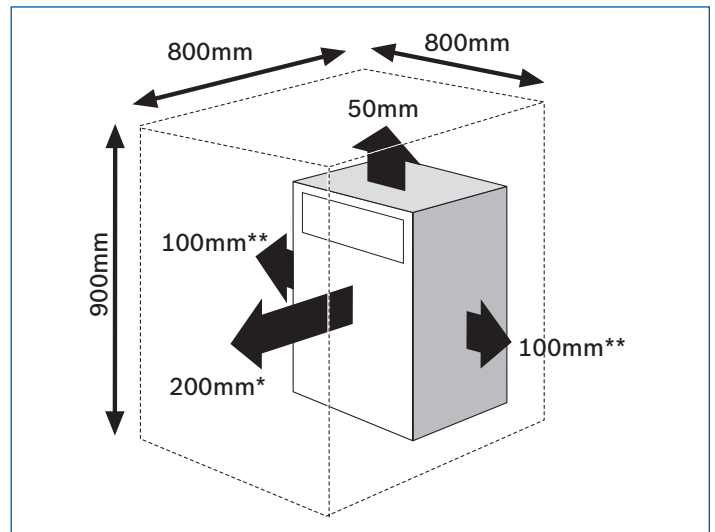

*Space required for unvented areas with a removable door or panel.

**This space can be reduced to 50mm for one side only as long as both the side clearances add up to the total of both the side measurements shown or more.

Airing cupboard clearances

The diagram below shows the minimum space required to install and service the boiler within an airing cupboard.

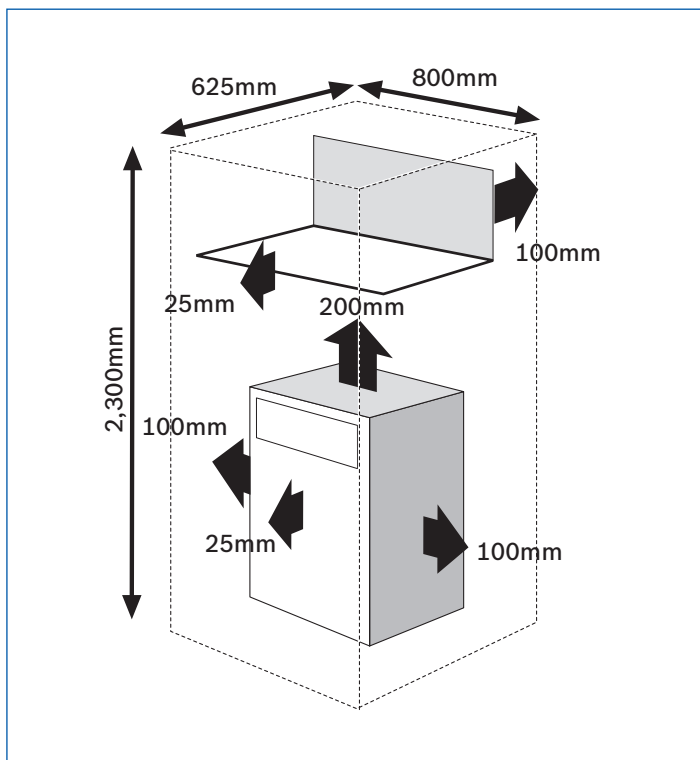

Venting compartments

If the clearances are less than those stated for the options above then ventilation must be provided as described in BS 5440.

A minimum of 2 air vents (A) must be fitted, one at low level and another at high level onto the same wall using the same air for circulation.

Minimum free air required for venting:

- For air directly from outside:
 - 440CDi 155cm² per vent
 - 550CDi 220cm² per vent
- For air from internal space/room:
 - 440CDi 310cm² per vent
 - 550CDi 440cm² per vent

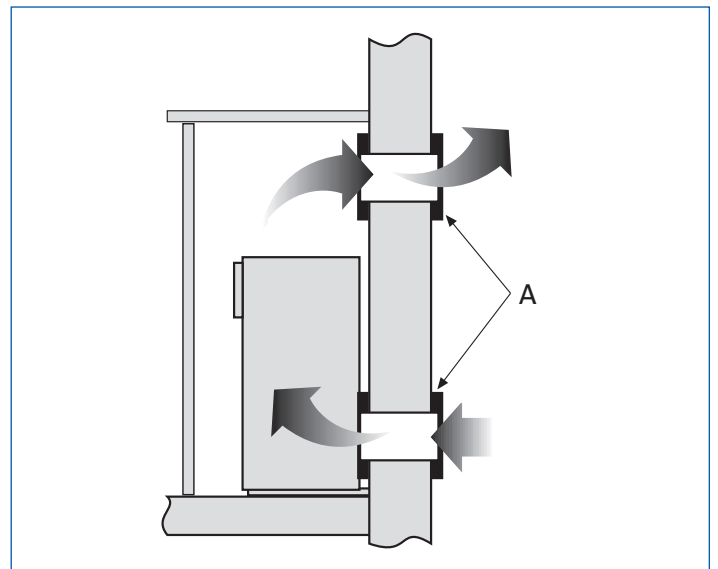

Bathrooms

IMPORTANT:

Any switch or appliance control using mains electricity must not be within reach of a person using the bath or shower.

Electrical switches, fused spurs and socket outlets must not be situated in the bathroom.

A boiler fitted with a non-mechanical timer or with no timer can be installed in zone 2 or outside the shaded area.

A boiler with a mechanical timer or RF mechanical timer with a room thermostat must only installed outside the shaded area.

Additional Residual Current Device (RCD) protection may be required.

Refer to the latest IEE wiring regulations.

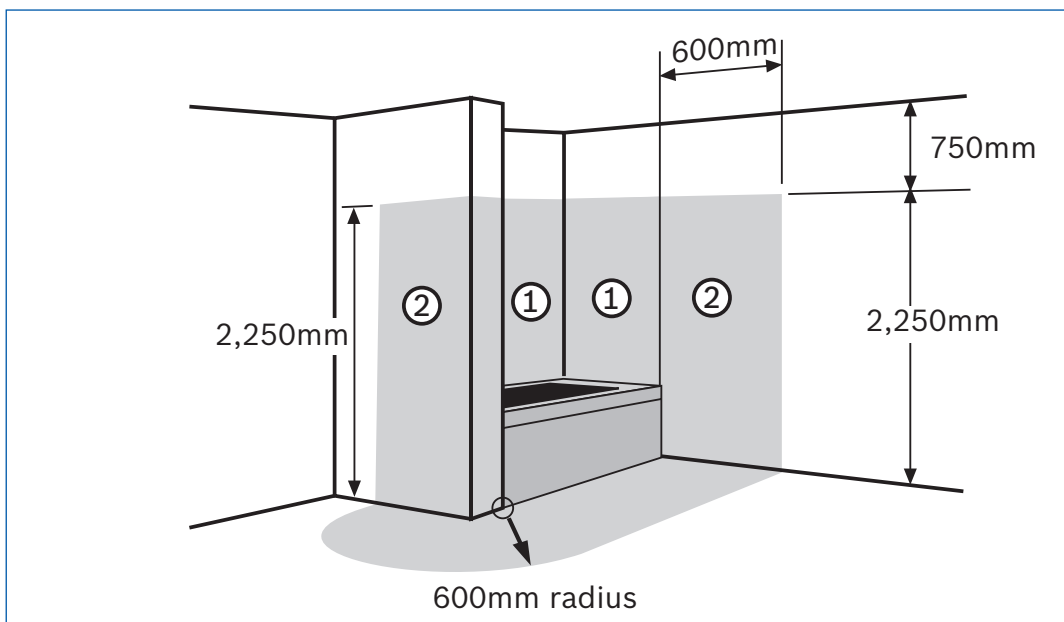
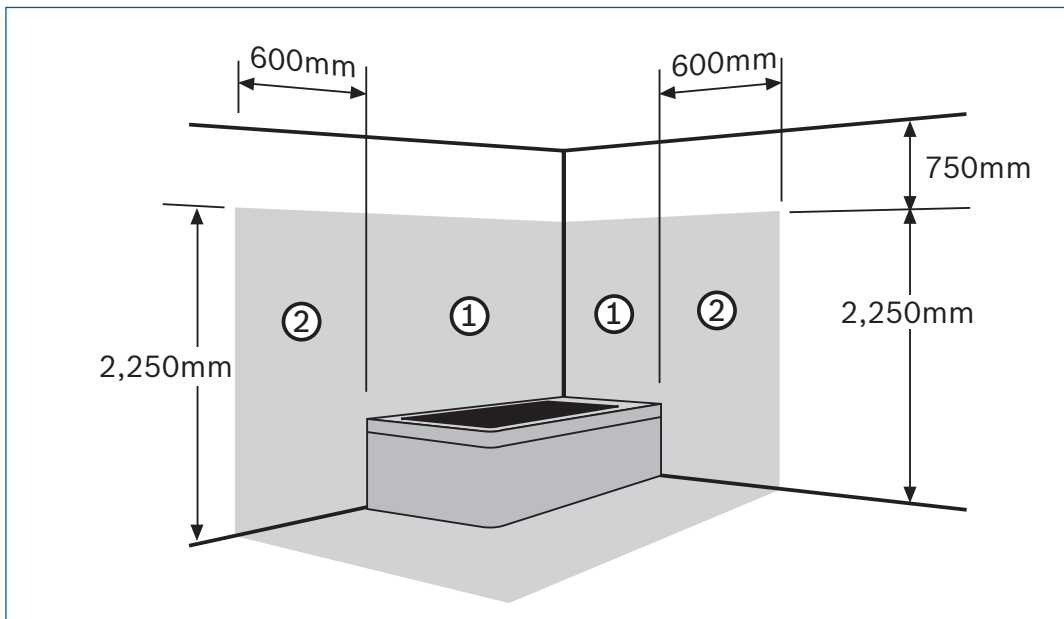

Flue terminal positioning

General position

1. The terminal must not cause an obstruction nor the discharge a nuisance. Particular care should be exercised with regards to the plumbing of the flue gases and any increase in noise levels.
2. If a terminal is fitted less than 2 metres above a surface to which people have access, then a guard must be fitted. A terminal protective guard is available from Tower Flue Components, Vale Rise, Tonbridge. Tel: (01732) 351555. The terminal guard must be securely fixed to the wall using suitable plugs and corrosion resistant screws. The guard must be such that there is a gap of 50mm between the end of the terminal and be symmetrically positioned about the terminal assembly and spaced the condense compatible guard.
3. In certain weather conditions, a white plume of condensation will be emitted from the flue terminal and siting where this could be a nuisance, i.e. near security lighting, should be avoided.
4. The air inlet/outlet duct and the terminal of the boiler must not be closer than 25mm to any combustible material. Detailed recommendations on protection of combustible materials are given in BS 5440:1.

The flue system must be installed and terminated in accordance with the recommendations of BS 5440:Part 1.

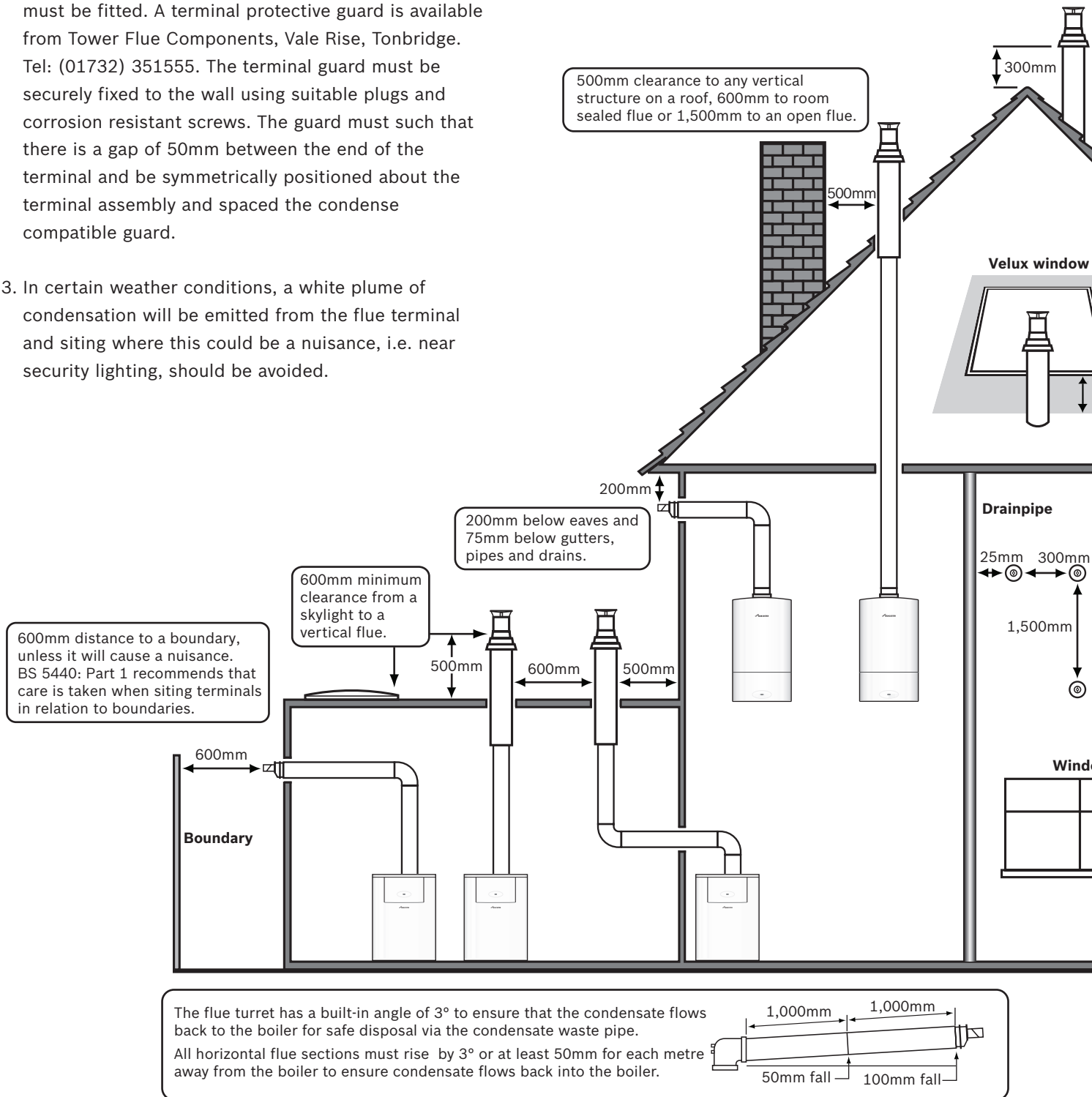

If plume management is utilised, the clearance from the flue air inlet to any opening can be decreased to 150mm in all cases, as long as the clearance from the flue outlet to any opening is maintained as shown on this diagram.

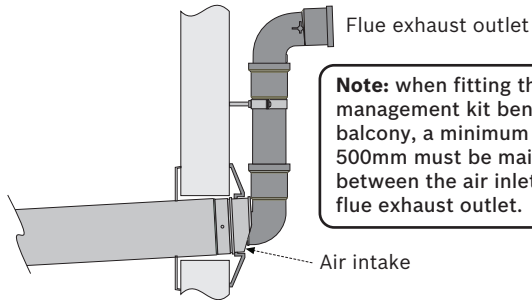

Note: when fitting the plume management kit beneath a balcony, a minimum of 500mm must be maintained between the air inlet & flue exhaust outlet.

NOTES:

Plume management kits are available for 100mm horizontally terminated flues. Please refer to the installation instructions supplied with the plume management kits.

If plume redirection is utilised, the clearance from any opening must be increased in the direction of the plume to 1,500mm.

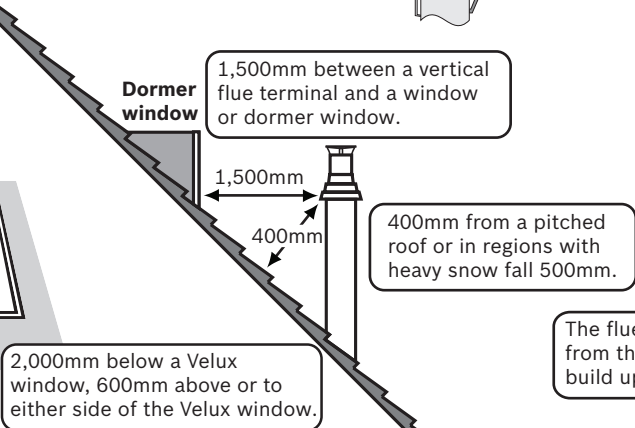
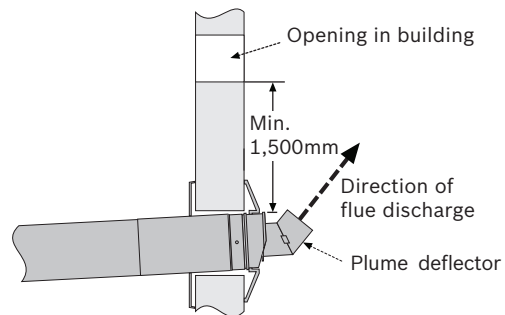

2,000mm below a Velux window, 600mm above or to either side of the Velux window.

The flue cannot be lower than 1,000mm from the top of a light well due to the build up of combustion products.

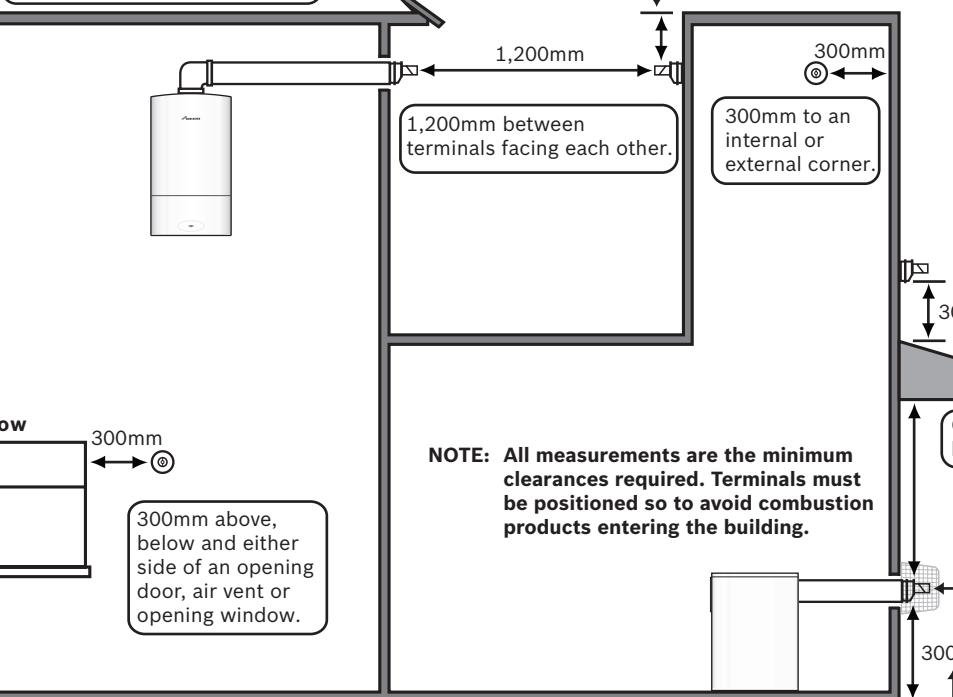

NOTE: All measurements are the minimum clearances required. Terminals must be positioned so to avoid combustion products entering the building.

Clearance no less than 200mm from the lowest point of the balcony or overhang.

NOTE: Installations in carports are not recommended.

1,200mm from an opening on the same wall (ie: door or window leading into a dwelling) in a carport with both sides open, to prevent the build up of combustion products.

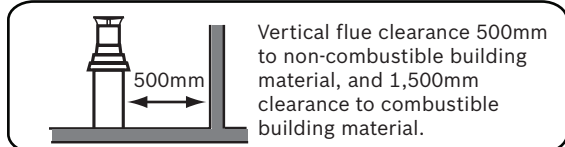
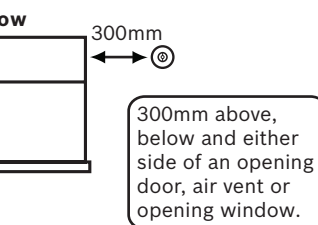

Flue clearances must be at least 300mm from the ground. Terminal guards must be fitted if the flue is less than 2 metres from the ground or if a person could come into contact with the flue terminal.

Greenstar Highflow CDi combi boiler horizontal fluing options

Greenstar Highflow CDi combis offer a choice of 2 different sized horizontal RSF flue systems, 100mm diameter and 125mm diameter. The systems have different maximum lengths. Options 1 to 8 detail the permissible lengths.

Horizontal RSF flue



| Flue diameter | 100mm | 125mm |
|---------------------|---------|----------|
| Minimum flue length | 130mm | 350mm |
| Maximum flue length | 4,000mm | 13,000mm |

100mm dia. telescopic flue kit

Comprises:

- 1 x internal flue connector bend
- 1 x flue adaptor
- 1 x flue connector
- 2 x wall cover plates
- 530mm (100mm dia.) of flue duct including terminal

Part No. 7 716 191 155

125mm dia. standard flue kit

- 1 x internal flue connector bend
- 1 x flue adaptor
- 1 x flue connector
- 2 x wall cover plates
- 965mm (125mm dia.) of flue duct including terminal

Part No. 7 716 191 157

Accessories

| Components | Part no. | Description |
|------------|---------------|--|
| | 7 716 191 155 | 60/100 530mm Horizontal telescopic kit |
| | 7 716 191 083 | 60/100 1m extension |
| | 7 716 191 084 | 60/100 90° bend |
| | 7 716 191 085 | 60/100 45° bend |
| | 7 716 191 133 | 60/100 Short flue extension |
| | 7 716 191 164 | 60/100 Vertical flue adaptor |
| | 7 716 191 157 | 80/125 965mm Horizontal flue kit |
| | 7 719 003 666 | 80/125 1m extension |
| | 7 719 003 664 | 80/125 90° bend |
| | 7 719 003 665 | 80/125 45° bend |
| | 7 716 191 165 | 80/125 Vertical flue adaptor |

*The 100mm flue system inclines 2° within the 100mm terminal.

The following criteria should be noted when planning the installation.

- The concentric flue system must be inclined at 3° (52mm per metre) from the appliance, to allow condensate to drain back into the boiler.
- Because the appliance operates at high efficiency a white plume of condensation will be emitted from the terminal. Care must be taken when selecting the flue terminal position (see pages 18 - 19).

Option 1

Extension rear flue horizontal flue assembly

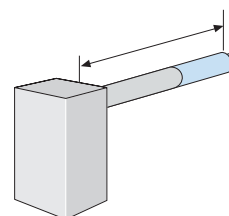

| Maximum length (m) | Components required | | |
|--------------------|---------------------|----------|--|
| | | | |
| 60/100 4 | 1 | up to 4 | |
| 80/125 13 | 1 | up to 12 | |

Option 2

Extension rear flue horizontal using a 90° bend

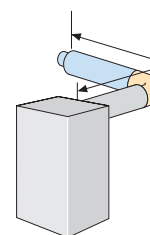

| Maximum length (m) | Components required | | | |
|--------------------|---------------------|----------|---|--|
| | | | | |
| 60/100 2.5 | 1 | up to 2 | 1 | |
| 80/125 11 | 1 | up to 10 | 1 | |



Deduct 750mm off the total flue length for every 45° bend used.

Deduct 1,500mm off the total flue length for every 90° bend used.

Option 3

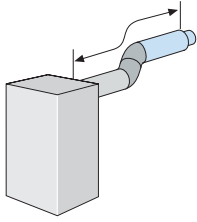
Extension rear flue horizontal using 45° bends





| Maximum length (m) | | Components required | | |
|--------------------|-----|---|---|---|
| | |  |  |  |
| 60/100 | 2.5 | 1 | up to 2 | 2 |
| 80/125 | 11 | 1 | up to 10 | 2 |

Option 4

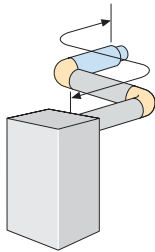
Extension rear flue horizontal using a second 90° bend





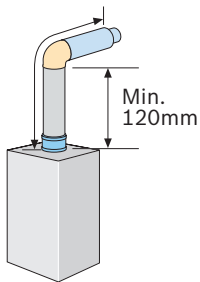

| Maximum length (m) | | Components required | | |
|--------------------|---|---|---|---|
| | |  |  |  |
| 60/100 | 1 | 1 | up to 2 | 2 |
| 80/125 | 9 | 1 | up to 8 | 2 |

Option 5

Extension flue upwards and horizontal





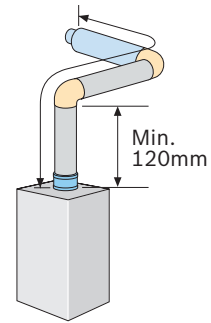

| Maximum length (m) | | Components required | | | |
|--------------------|-----|---|---|---|---|
| | |  |  |  |  |
| 60/100 | 2.5 | 1 | up to 2 | 1 | 1 |
| 80/125 | 11 | 1 | up to 10 | 1 | 1 |

Option 6

Extension flue upwards and horizontal using a second 90° bend





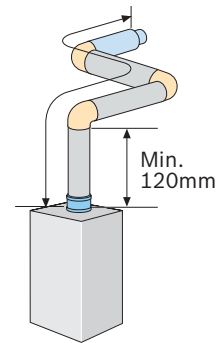

| Maximum length (m) | | Components required | | | |
|--------------------|---|---|---|---|---|
| | |  |  |  |  |
| 60/100 | 1 | 1 | up to 2 | 2 | 1 |
| 80/125 | 9 | 1 | up to 8 | 2 | 1 |

Option 7

Extension flue upwards and horizontal using a third 90° bend





| Maximum length (m) | | Components required | | | |
|--------------------|-----|---|---|---|---|
| | |  |  |  |  |
| 60/100 | N/A | N/A | N/A | N/A | N/A |
| 80/125 | 7 | 1 | up to 6 | 3 | 1 |

Option 8

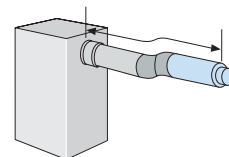
Side flue extension using two 45° bends



| Maximum length (m) | | Components required | | |
|--------------------|-----|---|---|---|
| | |  |  |  |
| 60/100 | 2.5 | 1 | up to 2 | 2 |
| 80/125 | 11 | 1 | up to 10 | 2 |

Greenstar Highflow CDi combi boiler vertical fluing options

Greenstar Highflow CDi combis offer a choice of 2 different sized vertical RSF systems, 100mm diameter and 125mm diameter. Both systems have different maximum lengths. Options 1 to 3 detail the permissible lengths.

Vertical RSF flue

| Flue diameter | 100mm | 125mm |
|-------------------------------------|---------|----------|
| Flue terminal assembly diameter | 120mm | 135mm |
| Maximum flue length (inc. terminal) | 6,400mm | 15,000mm |
| Flue terminal assembly length | 1,140mm | 1,365mm |

Vertical balanced flue kit









Comprises:

- 1 x flue terminal assembly
- 1 x weather sealing collar
- 1 x fire stop spacer
- 1 x vertical flue adaptor
- 1 x wall bracket
- 1 x flue adaptor

Part No. 7 716 191 156 (100mm dia.)

Part No. 7 716 191 158 (125mm dia.)



Accessories

| Components | Part no. | Description |
|---|---------------|-----------------------------|
|  | 7 716 191 156 | 60/100 Vertical 1,140mm kit |
|  | 7 716 191 083 | 60/100 1m extension |
|  | 7 716 191 084 | 60/100 90° bend |
|  | 7 716 191 085 | 60/100 45° bend |
|  | 7 716 191 133 | 60/100 Short flue extension |
|  | 7 716 191 158 | 80/125 Vertical 1,365mm kit |
|  | 7 719 003 666 | 80/125 1m extension |
|  | 7 719 003 664 | 80/125 90° bend |
|  | 7 719 003 665 | 80/125 45° bend |

Option 1

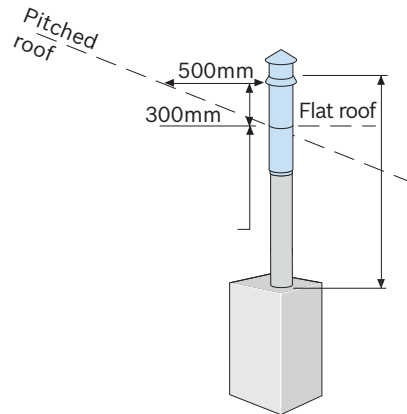
Vertical balanced flue assembly





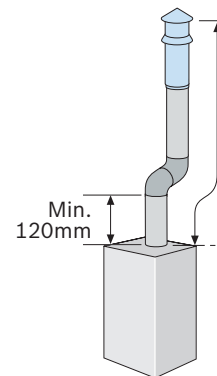

| Maximum length (m) | Components required | | |
|--------------------|---|---|---|
| |  |  |  |
| 60/100 6.4 | 1 | up to 6 | |
| 80/125 15 | 1 | up to 14 | |

Option 2

Vertical balanced flue using two 45° bends





| Maximum length (m) | Components required | | | |
|--------------------|---|---|---|---|
| |  |  |  |  |
| 60/100 4.9 | 1 | up to 5 | | 2 |
| 80/125 13 | 1 | up to 12 | | 2 |

Option 3

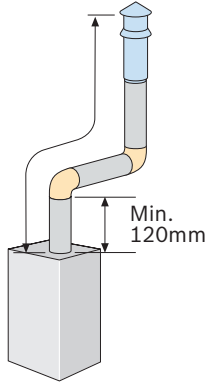
Vertical balanced flue using two 90° bends



| Maximum length (m) | | Components required | | |
|--------------------|-----|---|---|---|
| | |  |  |  |
| 60/100 | 3.4 | 1 | up to 3 | 2 |
| 80/125 | 11 | 1 | up to 10 | 2 |

Plume management system options

Plume management system

60mm dia. plume management kit

Comprises:

- 1 x terminal elbow
- 1 x extension 500mm
- 1 x outlet assembly
- 1 x clamp pack

Part No. 7 716 191 086

Accessories

| Components | Part no. | Description |
|------------|---------------|--------------------------------|
| | 7 716 191 086 | 60mm dia. Plume management kit |
| | 7 716 191 087 | 60mm dia. Extension (1,000mm) |
| | 7 716 191 088 | 60mm dia. 90° Bend |
| | 7 716 191 089 | 60mm dia. 45° Bend (pair) |

Standard plume management system

The flue terminal outlet has built-in stops to limit rotation for horizontal fluing to allow condensate to run back into the boiler for safe disposal. Do not attempt to force beyond the limit stops.

All plume management sections must rise by at least 173mm per metre (10°) from the terminal to ensure that condensate flows back into the boiler.

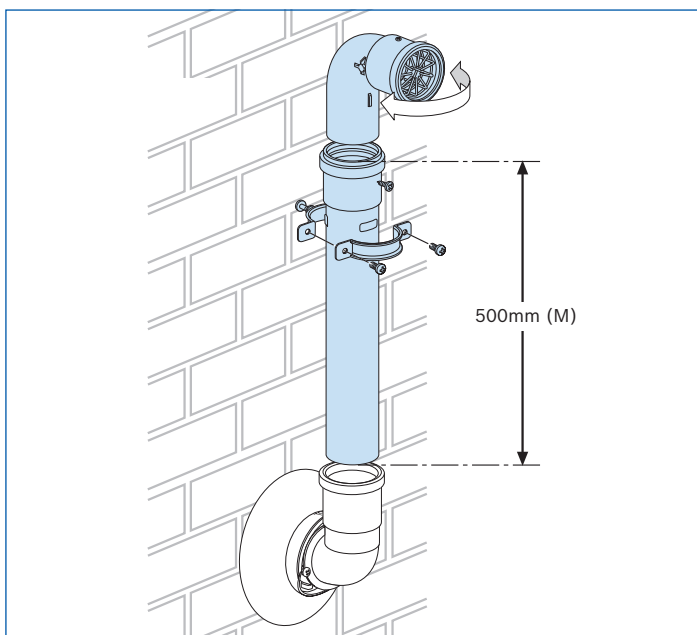

Re-directing flue discharge from a 60mm dia. plume management outlet

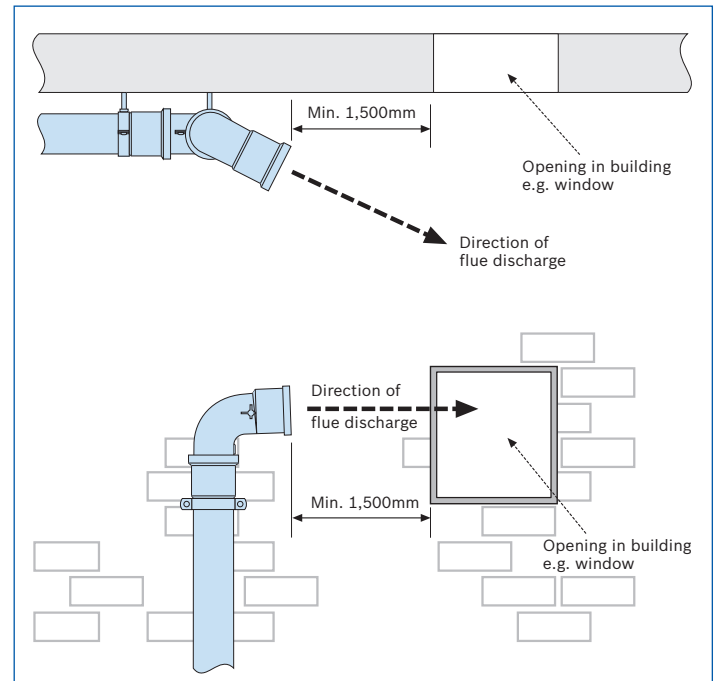

Condensfit II telescopic flue and plume management system measuring

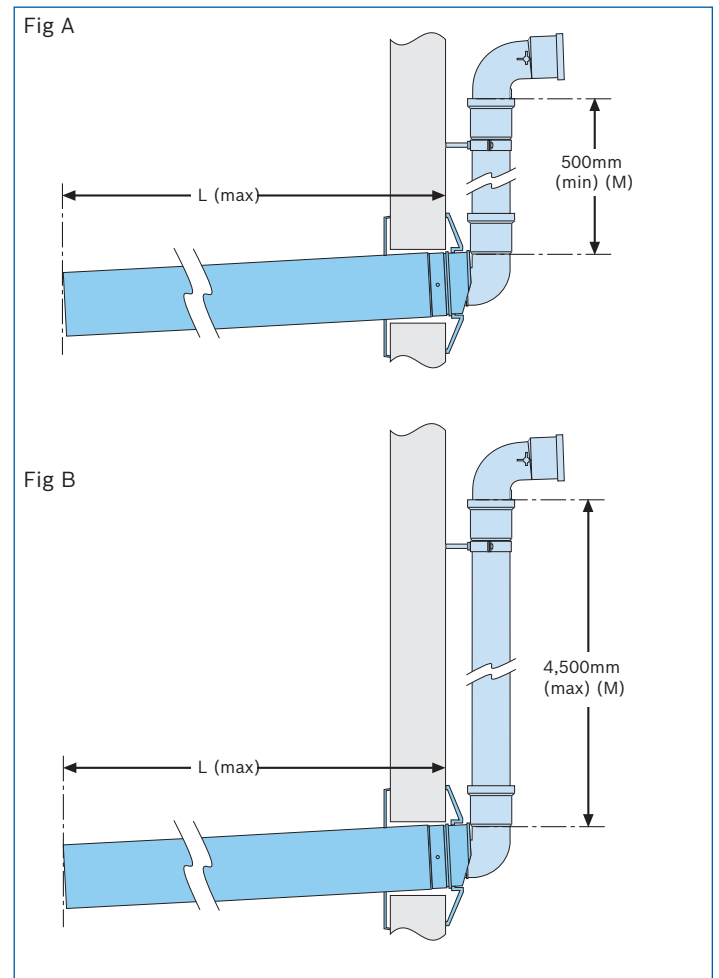

| Effective straight flue lengths for telescopic flue with plume management | | |
|---|---|---|
| Model | Fig. A Max. straight flue length (L) with min. plume management length (M)* (mm) | Fig. B Max. straight flue length (L) with max. plume management length (M)* (mm) |
| Highflow 440CDi** | 4,000 | 1,200 |
| Highflow 550CDi** | 4,000 | 1,200 |

NOTE:

Plume management minimum straight length = 500mm

Plume management maximum straight length = 4,500mm

****For every additional 1,000mm of plume management length (M), reduce flue length (L) by 700mm – see figures A and B.**

Condensfit II telescopic flue and plume management system measuring

100mm dia. horizontal telescopic flue lengths with a 60mm dia. plume management system

The maximum effective straight flue lengths (L) are stated opposite for the relevant appliance together with the minimum and maximum lengths (M) of the plume management system connected, these lengths must not be exceeded.

60mm dia. plume management system

To ensure that the maximum total straight flue length along the plume management route is not exceeded the following should be added to dimension (M):

- 1,500mm for each extra 90° bend
- 750mm for each extra 45° bend

For plume management options with 60mm dia. extensions refer to page 26.

Note: For information on the Condensfit II Telescopic Flue System and Plume Management Kit, please see dedicated flue Technical and Specification leaflet 8 716 112 174.

Flue length 'L' versus plume management kit

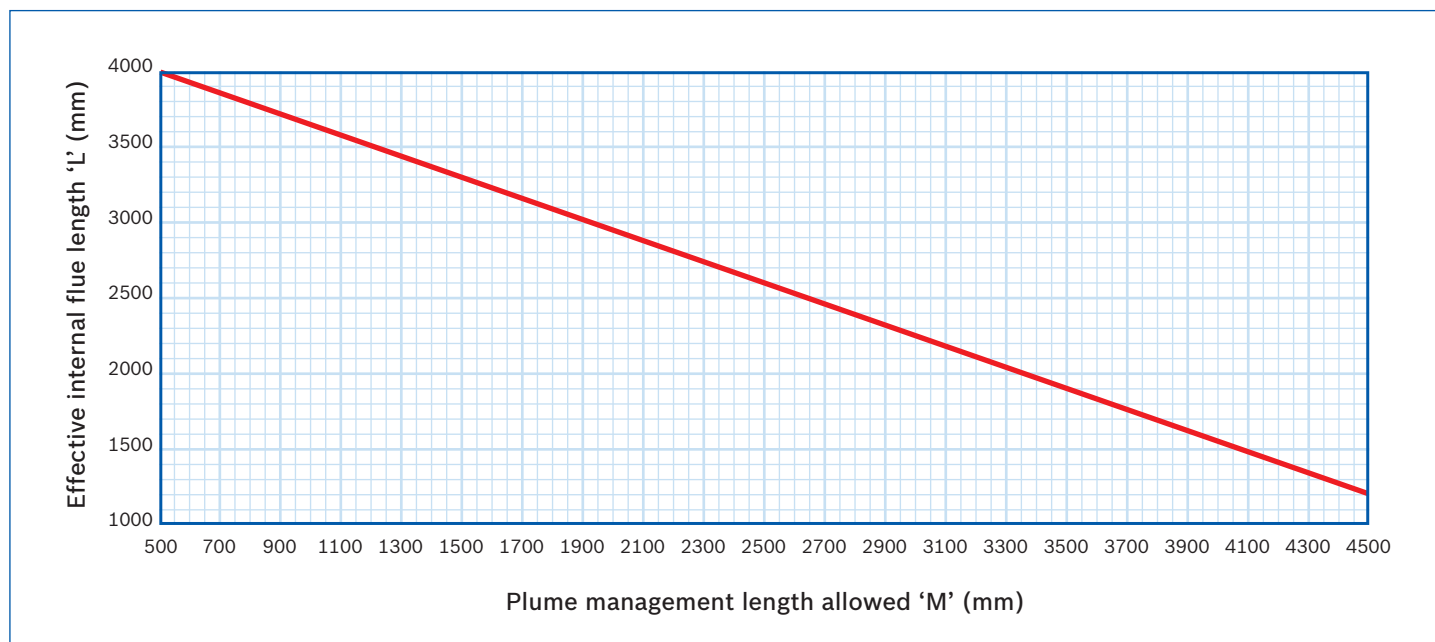

Use the graph above to determine the permissible plume management length that can be used with your effective flue length 'L'.

The effective flue length can be determined by adding together all the straight flue lengths and the effective lengths of the bends used, 1,500mm for each 90° bend and 750mm for each 45° bend.

Plume management options

See tables below for details of components required.

Option 1

Plume management system

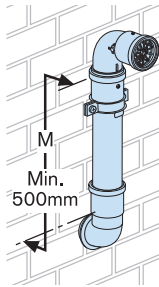

| Maximum length (mm) | | Components required | |
|-------------------------------|------|---------------------|--|
| Greenstar Highflow CDi series | | | |
| 60mm | 500* | 1 | |

Option 2

Plume management system with extensions

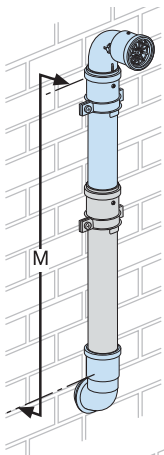

| Maximum length (mm) | | Components required | |
|-------------------------------|--------|---------------------|---------|
| Greenstar Highflow CDi series | | | |
| 60mm | 4,500* | 1 | up to 4 |

Option 3

Plume management system with extensions and 45° bend

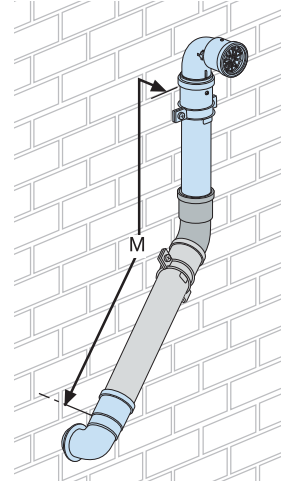

| Maximum length (mm) | | Components required | | |
|-------------------------------|--------|---------------------|---------|---|
| Greenstar Highflow CDi series | | | | |
| 60mm | 3,750* | 1 | up to 4 | 1 |

Option 4

Plume management system with angled termination

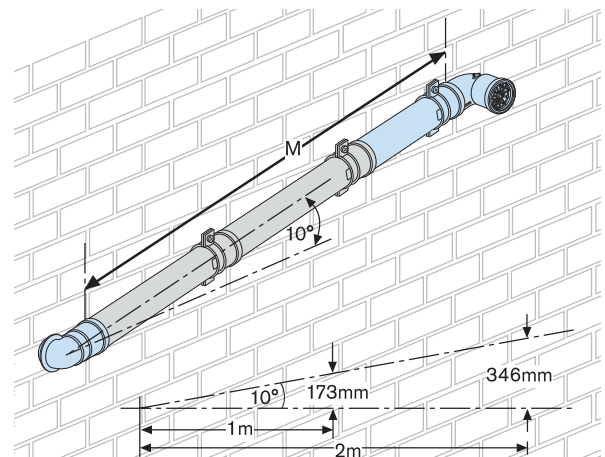





| Maximum length (mm) | | Components required | |
|-------------------------------|--------|---------------------|---------|
| Greenstar Highflow CDi series | | | |
| 60mm | 4,500* | 1 | up to 4 |

***NOTE: You must refer to the table on page 25 to calculate your horizontal flue lengths and plume management length.**

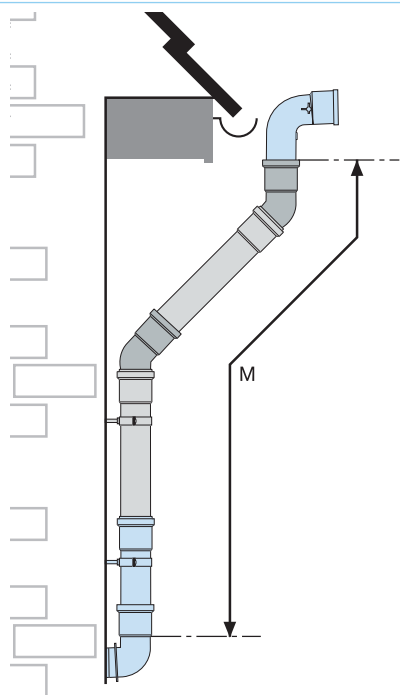
Option 5

Plume management system with extensions and 45° bends



| Maximum length (mm) | | Components required | | |
|--------------------------------------|--------|---|---|---|
| | |  |  |  |
| Greenstar Highflow CDi series | | | | |
| 60mm | 3,000* | 1 | up to 3 | 2 |

***NOTE: You must refer to the table on page 25 to calculate your horizontal flue lengths and plume management length.**

Installation requirements

Installation of Greenstar Highflow CDi combis must be in accordance with the relevant requirements of the Gas Safety (Installation Use) Regulations at the time of installation, current IEE Wiring Regulations, local Building Regulations, Building Standards (Scotland) regulations and bylaws of the local Water company and Health and Safety Document No. 635 (Electricity at Work Regulations 1989). It should be in accordance with the relevant recommendations of the following British Standards:

BS 6798; BS 5449; BS 5546:1; BS 5440:1; BS 5440:2; BS 6891.

Gas Safety (Installation and Use) Regulations. All gas appliances must be installed by a Gas Safe registered person in accordance with the above regulations. Failure to install appliances correctly could lead to prosecution.

The manufacturers notes must not be taken in any way as overriding statutory regulations.

Sealed primary systems

Worcester Greenstar Highflow CDi combis are supplied complete with all the necessary components to form a sealed primary system. Included are a pre-plumbed expansion vessel (12 litres), a pressure relief valve (set at 3bar), an automatic air vent and a pressure gauge.

The expansion vessel fitted to the appliance will accommodate differing system volumes, depending upon its initial charge pressure, and system pre-pressurisation. The table below shows the system volume that can be accommodated under different conditions. If it is found that the system volume exceeds that catered for by the expansion vessel fitted within the appliance, then an extra vessel should be added as close to the appliance as possible in the heating return pipe. Refer to BS 5449:1 and BS 6798:1 for further information.

| Total system volume – litres (gallons) | | | |
|--|-------------------------------|------------|-----------|
| Initial system pressure (bar) | Initial charge pressure (bar) | | |
| | 0.5 | 1.0 | 1.5 |
| 0.5 | 130 (29) | – | – |
| 1.0 | 80 (17.5) | 102 (22.5) | – |
| 1.5 | 43 (9.5) | 58 (13) | 71 (15.5) |
| 2.0 | 20 (4.5) | 27 (5.9) | 33 (7.5) |

System filling and make-up

To comply with the Water Authority requirements, the system should be filled via a temporary hose connection to the mains cold water supply, with a double check valve assembly and a test point fitted to the mains water side of the temporary circuit. This is supplied within the boiler.

Valves and joints

It is very important that all valves and joints are able to sustain a working pressure of up to 3bar (45psi). Particular care should be exercised when fitting radiator valves and only those of high quality to BS 2767:10 should be used. All other valves and fittings should comply with BS 1010.

Loss of water pressure from a sealed system will require continuous recharging with fresh water and consequential introduction of air. Air is highly corrosive and will considerably reduce life expectancy of radiators, pumps etc.

Plastic pipework

The use of plastic pipework is acceptable. However, some plastics are permeable to oxygen and must be avoided. Only pipework with a polymeric barrier should be used. Please note that the first 600mm of pipework connected to the boiler must be copper.

Open vented primary systems

It is not permissible to install a Greenstar Highflow CDi combi on an open vent system.

Natural gas supply

Appliances, when on a full output demand, will require up to 3.1m³/hr of gas for the 440CDi and 4.4m³/hr of gas for the 550CDi. The gas meter and supply pipes must be capable of supplying this quantity of gas in addition to the demand from any other appliance being served. It is important that a gas supply pipe of at least 22mm diameter is used. Under no circumstances should the size of the gas supply pipe be less than that of the appliance inlet connection. The meter outlet should be capable of ensuring a nominal pressure of 20mbar (8in wg) at the appliance. Particular consideration should be given to the resistance to gas flow created by elbows, bends etc. Pipework should be sized to overcome this resistance, details of this are given in the table below.

| | Total length of gas supply pipe (m) | | | Pipe diameter (mm) |
|-----------------------------|-------------------------------------|------|-----|--------------------|
| | 3 | 6 | 9 | - |
| Gas | 2.9 | - | - | 15 |
| discharge | 8.7 | 5.8 | 4.6 | 22 |
| rate m³/h | 18.0 | 12.0 | 9.4 | 28 |

Approximate additional length to be allowed (natural gas)

| Elbows or tees | | 90° bends | |
|----------------|------|-----------|------|
| Metres | Feet | Metres | Feet |
| 0.50 | 2 | 0.3 | 1 |

Liquid Petroleum Gas (LPG) supply

An LPG kit is an available accessory for Greenstar Highflow CDi combis. The appliances, when on a hot water or full output demand, will require up to 2.3kg/hr of gas for the 440CDi and 3.2kg/hr of gas for the 550CDi. The gas tank or bottles must be capable of supplying this quantity of gas at a nominal pressure of 37mbar (14.8in wg) at the appliance. The table below shows the LPG discharge through varying lengths of pipe and the resistance to flow created by elbows, bends etc. Pipework should be sized so as to overcome this resistance.

| | Total length of gas supply pipe (m) | | | Pipe diameter (mm) |
|-----------------------------|-------------------------------------|-----|-----|--------------------|
| | 3 | 6 | 9 | - |
| Gas discharge | 8.0 | 5.2 | 4.2 | 22 |
| rate m³/h | 15.9 | 8.8 | 8.3 | 28 |

Approximate additional length to be allowed (LPG)

| Elbows or tees | | 90° bends | |
|----------------|------|-----------|------|
| Metres | Feet | Metres | Feet |
| 0.6 | 2 | 0.3 | 1 |

Electricity supply

A 3amp fused three pin plug and unswitched shuttered socket outlet (both complying with BS 1363) or preferably a double pole isolator with a contact separation of 3mm in all poles supplying the appliance should be used.

The appliance electrical circuits are also protected by an internal 2.5amp fuse. The appliance must be earthed.

Mains cold water supply

Water Authority requirement

A direct mains cold water connection is permitted by Water Authorities, however, it is recommended that reference be made to local requirements. In the event of difficulty contact the Worcester Technical Support Department.

Pipe sizing

Unless the mains pressure is low, a standard 22mm diameter service pipe is normally suitable. A 22mm hot water distribution pipe to the first branch is recommended thereafter 15mm and/or 10mm to all draw off points.

Cold water connection

Wherever possible the cold supply to the appliance should be the first connection off the mains supply, in order to minimise hot water flow reduction when cold water services are operated. The final 600mm of piping to the appliance should be of copper only.

Cold water pressure

To achieve the stipulated flow rates of 20l/min (4.4gpm)/ 25l/min (5.5gpm) a working cold water mains pressure of 1.5bar/1.7bar is required. The appliance will operate at a minimum working pressure of only 0.5bar (7.5psi) however a reduced hot water flow rate should be expected. Back-flow prevention devices, including water meters, can prevent the expansion of hot water into the cold water main. However, this can result in a pressure build-up that may cause damage to the boiler and household devices such as showers, washing machines etc. In these cases we recommend that a mini-expansion vessel (Part No. 7 716 192 105) be fitted adjacent to the boiler in the cold water main.

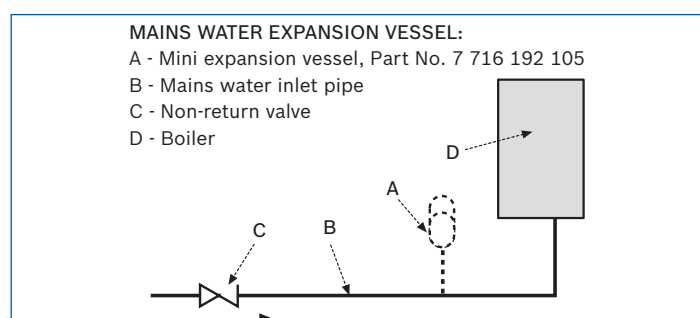

Hot water supply

As with all mains fed systems, the flow rate of water obtainable from individual taps will vary in relation to the number of taps operating simultaneously, and will depend upon the cold mains supply available to the property.

Therefore, in order to avoid excessive starvation of flow to individual taps, flow balancing may be required by the use of proprietary constant volume flow regulators or Ball-o-Fix valves.

Hot water systems

Taps and valves

Hot and cold taps and mixing valves used with Greenstar Highflow CDi appliances must be suitable for operating at a mains pressure of up to 10bar (150psi) and temperatures of 65°C (150°F).

Showers

When a loose head shower with a flexible hose is used over a bath or shower tray, the hose must be fixed so that the head cannot fall closer than 25mm (1in) above the top edge of the spill over level of the relevant bath or shower tray. Alternatively, the feed pipes to the shower should incorporate a double check valve assembly or a check valve and vacuum breaker.

With fixed head showers no provision is necessary.

The use of a thermostatically controlled shower will give added comfort and safeguard against high hot water temperatures.

Bidet

The supply of hot and cold water mains direct to a bidet is permitted provided that the bidet is of the overrim water feed type. The outlet(s) should be shrouded and not have any temporary hand held spray attached. No other anti-siphonage arrangements are necessary.

Use in hard water areas

As the maximum temperature of the domestic hot water heat exchanger is limited by the electronic control circuit, there is normally no need for water treatment to prevent scale accumulation.

In areas where exceptional water conditions prevail, consideration may need to be given to the fitting of a device capable of preventing scale. In such circumstances the advice of the local water authority should be sought.

Warranty

Worcester Greenstar Highflow CDi appliances are offered with a full 2 year guarantee* on parts and labour, a 10 year warranty* on the primary heat exchanger and a 5 year warranty* on the plate heat exchanger. Ongoing service and maintenance contracts can be arranged through the Worcester Customer Service Department.

**Subject to conditions.*

Greenstar Highflow CDi series accessories

| | | | |
|---|--|--|--|
| <p>MT10 mechanical timer</p>  <p>Worcester Part No. 7 716 192 036</p> | <p>MT10RF mechanical RF thermostat</p>  <p>Worcester Part No. 7 716 192 037</p> | <p>DT20 twin channel digital programmer</p>  <p>Worcester Part No. 7 716 192 038</p> | <p>DT20RF digital RF thermostat with twin channel programmer</p>  <p>Worcester Part No. 7 716 192 054</p> |
| <p>DT10RF digistat</p>  <p>Worcester Part No. 7 716 192 052</p> | <p>DT10RF optimiser</p>  <p>Worcester Part No. 7 716 192 053</p> | <p>RT10 room thermostat</p>  <p>Worcester Part No. 7 719 002 505</p> | <p>TD200 text display</p>  <p>Worcester Part No. 7 719 002 506</p> |
| <p>Text display wall mounting socket</p>  <p>Worcester Part No. 7 719 002 718</p> | <p>RS telescopic flue kit (100mm dia.)</p>  <p>Worcester Part No. 7 716 191 155</p> | <p>Horizontal flue kit (125mm dia.)</p>  <p>Worcester Part No. 7 716 191 157</p> | <p>Vertical BF kit (100mm dia.)</p>  <p>Worcester Part No. 7 716 191 156</p> |
| <p>Vertical BF kit (125mm dia.)</p>  <p>Worcester Part No. 7 716 191 158</p> | <p>Vertical flue adaptor (60/100mm)</p>  <p>Worcester Part No. 7 716 191 164</p> | <p>Vertical flue adaptor (80/125mm)</p>  <p>Worcester Part No. 7 716 191 165</p> | <p>1,000mm extension kit (100mm dia.)</p>  <p>Worcester Part No. 7 716 191 083</p> |

Note: For information on the Condensfit II Telescopic Flue System and Plume Management Kit, please see dedicated flue Technical and Specification leaflet 8 716 112 174.

Greenstar Highflow CDi series accessories

**Short flue extension
220mm (100mm dia.)**



**Worcester Part No.
7 716 191 133**

**1,000mm extension
(125mm dia.)**



**Worcester Part No.
7 719 003 666**

**45° bend
(100mm dia.)**



**Worcester Part No.
7 716 191 085**

**45° bend
(125mm dia.)**



**Worcester Part No.
7 719 003 665**

**90° bend
(100mm dia.)**



**Worcester Part No.
7 716 191 084**

**90° bend
(125mm dia.)**



**Worcester Part No.
7 719 003 664**

**Support bracket kit
(100mm dia.)**



**Worcester Part No.
7 716 191 092**

**Plume management kit
(60mm dia.)**



**Worcester Part No.
7 716 191 086**

**Extension
(60mm dia., 1,000mm)**



**Worcester Part No.
7 716 191 087**

**90° bend
(60mm dia.)**



**Worcester Part No.
7 716 191 088**

**45° bend
(60mm dia.)**



**Worcester Part No.
7 716 191 089**

**Flat roof flashing kit
(100mm & 125mm dia.)**



**Worcester Part No.
7 716 191 090**

**Pitched roof flashing kit
(100mm & 125mm dia.)**



**Worcester Part No.
7 716 191 091**

Note: For information on the Condensfit II Telescopic Flue System and Plume Management Kit, please see dedicated flue Technical and Specification leaflet 8 716 112 174.

A complete after-sales service

As part of the worldwide Bosch Group, Worcester strives to maintain the highest possible standards of after-sales care.

In addition to the no-nonsense parts and labour warranty applicable to all Worcester boilers, you and your customers have the assurance that every Worcester boiler is manufactured to both the appropriate British and European standards.

Worcester Contact Centre

Should you require support, our fully trained Contact Centre staff, based at our head office in Worcester, are ready to take your calls. Whatever your query our contact centre operators along with our nationwide team of engineers are ready to help you.

Boiler Protection Options

Worcester offers boiler protection including service and maintenance contracts. Please call the Worcester Contact Centre for further details.

If you do not offer annual service and maintenance contracts please refer your customers to the Worcester Contact Centre:

Tel: 08457 256 206

Fax: 01905 757 536

Opening Times

Monday – Friday: 7.00am – 8.00pm

Saturday: 8.00am – 5.00pm

Sunday: 9.00am – 12 noon

All the technical advice you need

Spares

Genuine replacement parts for all Worcester boilers are readily available from stock, on a next day delivery basis. For more information please call your local stockist. You can find a spares stockist on our website.

Customer Technical Support

The Worcester Technical Helpline is a dedicated phone line – committed to providing a comprehensive service to complement the brand name and quality of our products. Our experienced team of technical experts provides answers to queries of a technical nature across the entire Worcester range.

Worcester also has a pre-sales department, which provides assistance in selecting a boiler system to suit a particular application, along with full guidance on installation. As well as this we will also assist in finding a recommended installer. For more information please contact the Technical Helpline or alternatively visit our website where literature can be downloaded at www.worcester-bosch.co.uk

Technical

Tel: 0844 892 3366

Fax: 01905 752 741

Opening Times

Monday – Friday: 7.00am – 8.00pm

Saturday: 8.30am – 4.00pm

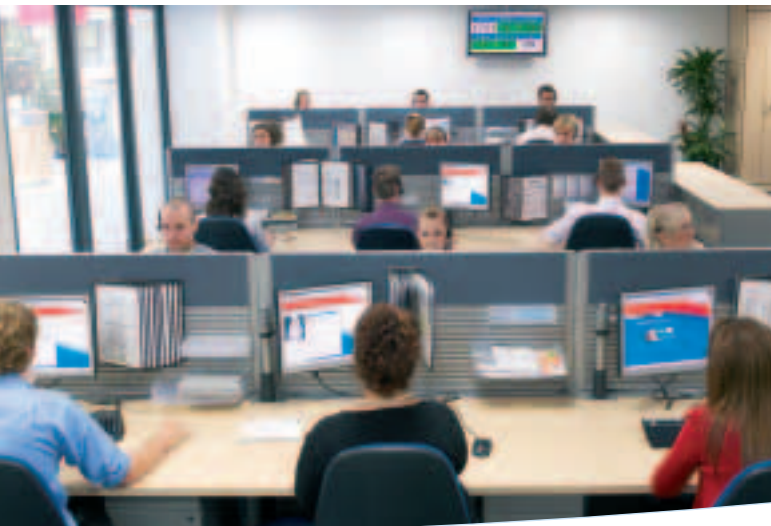

The very best training programmes from Worcester



Worcester has always placed great emphasis on technical support and training for installers and service engineers. Today this need is greater than ever. The differences between a combi, conventional and system boiler are substantial, and the technology of each continues to advance at a rapid pace.

With the increase of renewables technologies in the UK, the need for training has never been greater.

To ensure the highest levels of competence and expertise in the installation of all Worcester products, the company runs intensive training courses for installers, commissioning engineers and operatives involved with servicing and fault finding.

Courses available

Our training facilities offer a number of courses suitable for the installer and commissioning engineers, and a more in-depth course for the servicing and fault finding engineers.



Training lab at West Thurrock Academy

Training Centres throughout the UK

Worcester's network of regional training venues is strategically located across the country and includes our state-of-the-art Academy at the Company Headquarters in Worcester. This facility has recently been upgraded to include a heat pump training lab, showcasing our range of ground and air source heat pumps.

Further academies are located at West Thurrock in Essex, Bradford, Clay Cross in Derbyshire and Bangor in Northern Ireland, all offering our full suite of courses. Please phone 01905 752526 for more information about a course near you. Each course is run by specialist trainers and is superbly equipped to deliver a combination of classroom theory and practical hands-on experience that's second to none.

College-linked Learning

As well as offering training at our own centres, Worcester has established close partnerships with many colleges around the UK, equipping them with our latest products. Call us on 01905 752526 to find out when we will be running the course of your choice at a college in your area.

Mobile training

To complement our training venues across the country, we can also bring training to you.

We have mobile vehicles fully equipped with operational Greenstar gas-fired boilers, dry strip-down models and even a Greensource Air to Air Heat Pump, ensuring that quality training in a comfortable environment can be achieved on your doorstep!

If it's oil training you require, our 7.5 tonne mobile oil vehicle is available throughout the country for hands-on product training and OFTEC assessments.

Distance Learning/Web Based Learning

Worcester has produced a selection of Distance Learning CD ROMs/DVDs which are packed with information. Call 01905 752556 for your copies, or visit www.worcester-bosch.co.uk for information on Web Based Learning.

Get on course for a more profitable future now.

Call now for more information 01905 752526



www.worcester-bosch.co.uk

Worcester training courses

One stop shop training

We are here to provide you with training and assistance for all areas of your business, not just product training. IT Skills and Sales & Marketing are just 2 of the courses we now offer to help your business grow. Call us on 01905 752526 to order a full training course portfolio.

| Worcester training courses | |
|---|--|
| Greenstar CDi gas-fired condensing combi boilers | |
| Models covered | Greenstar 27/30/37/42CDi |
| Duration | 1 day |
| Greenstar i Junior & Si gas-fired condensing combi boilers | |
| Models covered | Greenstar 24/28i Junior Greenstar 25/30Si |
| Duration | 1 day |
| Greenstar Highflow CDi & FS CDi regular floor standing gas-fired condensing combi and regular boilers | |
| Models covered | Greenstar Highflow 440/550CDi Greenstar FS 30/42CDi Regular |
| Duration | 1 day |
| Greenstar system & regular gas-fired condensing boilers | |
| Models covered | Greenstar 12/15/18/24Ri Greenstar 30/40CDi Conventional Greenstar FS 30/42CDi Regular Greenstar 30CDi System Greenstar 12/24i System |
| Duration | 1 day |
| Greenstar FX controls | |
| Models covered | MT10/MT10RF/DT20RF/DT20/DT10RF/TD200/RT10/ FR10/FR110/FW100/ISM1 |
| Duration | 1 day |
| Greenstar Danesmoor, Heatslave & Camray high efficiency condensing oil-fired boilers – pre-OFTEC training | |
| Models covered | Greenstar Danesmoor series Greenstar Heatslave series Greenstar Camray series |
| Duration | 1 day |
| Greenskies solar system | |
| Covering | Installation, Commissioning and Servicing |
| Duration | 2 days |
| Greenstore ground source heat pumps | |
| Covering | Installation, Commissioning and System Design |
| Duration | 2 days |
| Greensource heat pumps – air to water | |
| Covering | Installation, Commissioning and System Design |
| Duration | 2 days |
| Greensource heat pumps – air to air | |
| Covering | Installation, Commissioning and System Design |
| Duration | 1 day |

OFTEC ASSESSMENT

OFTEC 101

| | |
|----------|--|
| Covering | Domestic/Light Commercial Pressure Jet Commissioning and Servicing |
| Duration | 3 day course |

OFTEC 105e

| | |
|----------|--|
| Covering | Domestic/Light Commercial Pressure Jet Boiler Installation |
| Duration | 1 day assessment |

OFTEC 101 & 105e

| | |
|----------|--|
| Covering | Domestic/Light Commercial Pressure Jet Installation, Commissioning and Servicing |
| Duration | 3 day course |

OFTEC 600a

| | |
|----------|---|
| Covering | Oil Tank Installation and Associated Controls |
| Duration | 1 day assessment course |

OFTEC 101/105e/600e

| | |
|----------|--|
| Covering | Domestic/Light Commercial Pressure Jet Boiler Installation, Commissioning, Servicing and Oil Tank Installation and Associated Controls |
| Duration | 4 days |

Mobile OFTEC

All above covered throughout the country on the mobile training vehicle as well as in all our centres.

Unvented cylinder course

| | |
|----------|--|
| Covering | All G3 Regulations for the Installation, Servicing and Commissioning of Unvented Cylinders. This course is certified by Logic Certification. |
| Duration | 1 day |

Chemical water treatment

| | |
|----------|--|
| Covering | Water treatment of domestic heating systems in accordance with BS 7593: 2006 |
| Duration | 1 day |



NB: Please note to attend OFTEC courses you must have a minimum of 12 months' experience installing/servicing oil boilers. For inexperienced candidates, our Greenstar Danesmoor, Heatslave and Camray course offers pre-OFTEC training.

Useful numbers

Sales

Tel: 01905 752640
Fax: 01905 456445

Spare Parts

Tel: 01905 752576
Fax: 01905 754620

Technical Helpline (Pre & Post Sales)

Tel: 0844 892 3366
Fax: 01905 752741

Renewables Technical Helpline

Email: renewable.energy@uk.bosch.com
or telephone 0844 892 4010

Training

Tel: 01905 752526
Fax: 01905 752535

Literature

Email: literature@uk.bosch.com
or download instantly from our website
or telephone 0844 892 9800

Customer Service

Engineer Appointments

Email: appointment.worcester@uk.bosch.com
or telephone 0844 892 3000

Enquiries

Email: service.mailbox@uk.bosch.com
or telephone 0844 892 3000

Guarantee Registration

To register your Worcester guarantee,
please visit our website or
telephone 0844 892 2442

Calls to the listed 0844 numbers are charged at up to 3 pence per minute from BT land lines.
Calls from mobiles and some other networks may vary. Calls to and from Bosch Thermotechnology Ltd
may be recorded for training and quality assurance purposes.

www.worcester-bosch.co.uk



In partnership with



Worcester, Bosch Group is a brand name of Bosch Thermotechnology Ltd.

This leaflet is accurate at the date of printing, but may be superseded and should be disregarded if specification and/or appearances are changed in the interest of continued improvement. The statutory rights of the consumer are not affected.

Part No. 8 716 106 250 E 01/10



BBT2163



Worcester, Bosch Group,
Cotswold Way, Warndon,
Worcester, WR4 9SW
Tel: 0844 892 9900 Fax: 01905 754619