

28I RSF

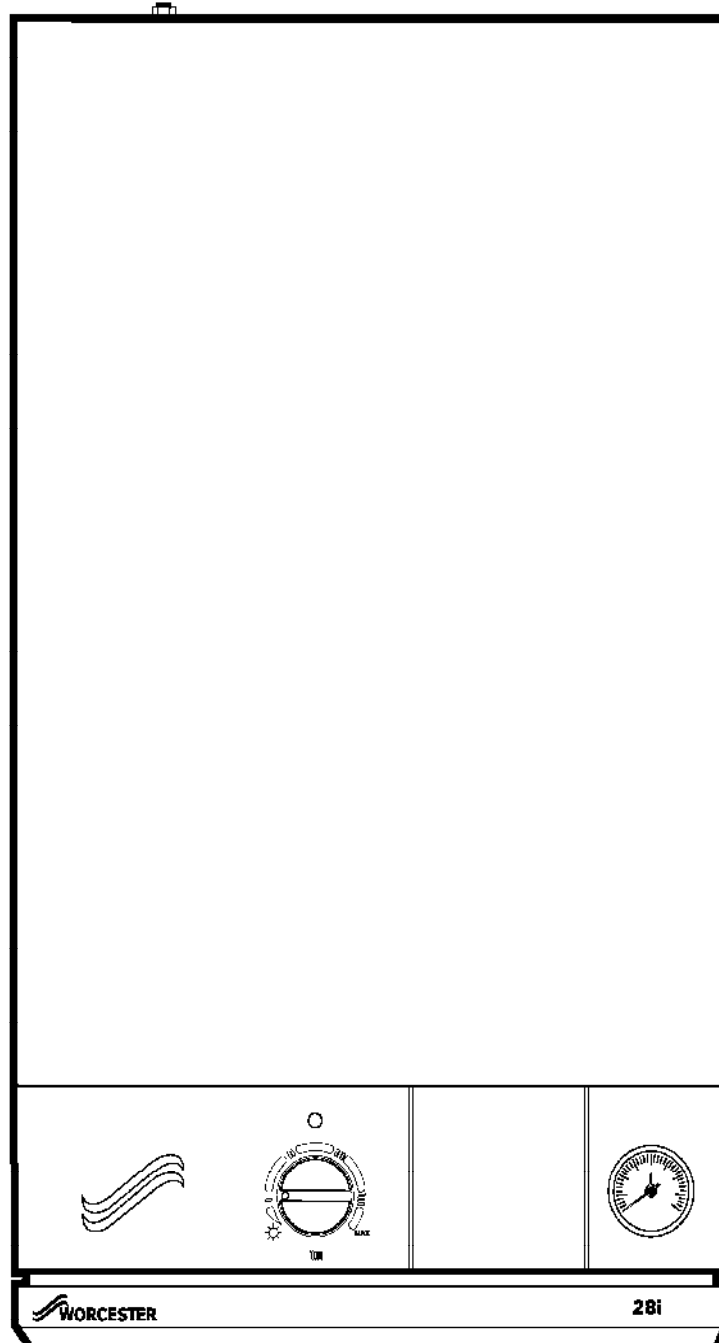

- 1 Pump &
 - 2 Hydraulic Assy
 - 3 Superstructure
 - 4 Electrical Box
 - 9 Assy
 - Casing
 - Additional Spare
 - Parts
- 6720900088.AA

Spare parts list

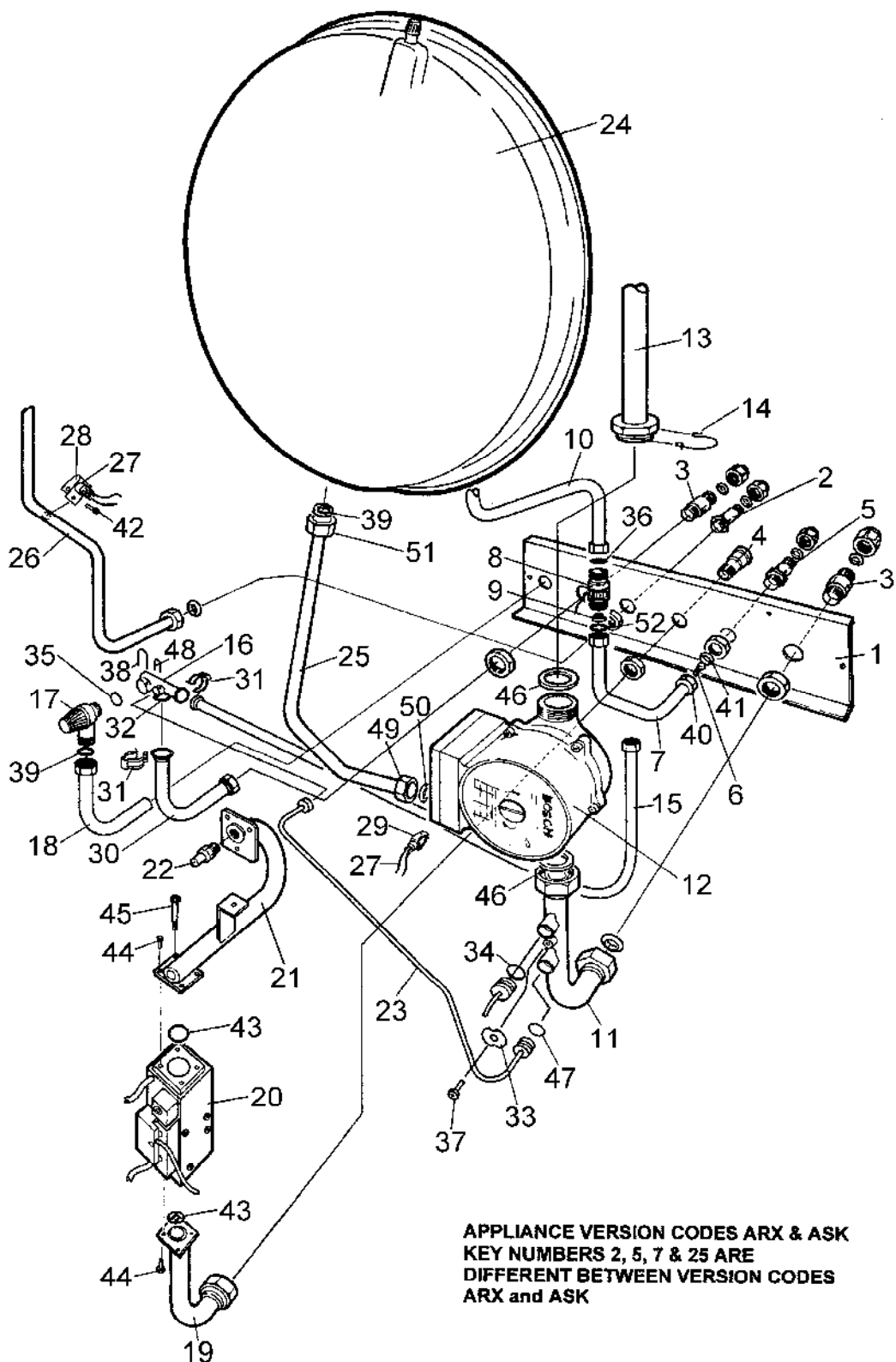

APPLIANCE VERSION CODES ARX & ASK
 KEY NUMBERS 2, 5, 7 & 25 ARE
 DIFFERENT BETWEEN VERSION CODES
 ARX and ASK

6720900089.AA

Pump / Hydraulic assy
 D

28I-FSN

1

Pos	description	S-Nr	ordering no.	PG	gas type	28i-FSN												remarks
1	Service connection plate		8 716 100 266 0		NG	■												
2	Blkhd union 15mmx15mm		8 716 102 350 0		NG	■												Version code: ARX
2	Blkhd valve-15mm x 15mm		8 716 142 428 0		NG	■												Version code: ASK
3	18-22mm isolating valve		8 716 142 410 0		NG	■												
4	Gas cock 1/2 bspt & g5/8 ma		8 716 142 424 0		NG	■												
5	Isolator valve 15mm		8 716 102 349 0		NG	■												Version code: ARX
5	Isolator valve 15mm-one c/nut		8 716 142 418 0		NG	■												Version code: ASK
6	Gauze filter		8 716 148 401 0		NG	■												
7	Pipe - flow switch inlet		8 716 100 964 0		NG	■												Version code: ARX
7	Pipe - flow switch inlet		8 716 102 378 0		NG	■												Version code: ASK
8	Harness turbine flow switch assy		8 716 146 160 0		NG	■												
9	Flow limiter insert 10lt		8 716 141 057 0	18	NG	■												
10	Pipe - flow switch outlet assy		8 716 121 223 0		NG	■												
11	Primary return assembly		8 716 121 573 0		NG	■												
12	Standard 15/60 Pump Head		8 716 113 594 0		NG	■												
12	Pump grundfos 59506606		8 716 143 107 0		NG	■												
13	Pipe - pump outlet assembly		8 716 120 968 0		NG	■												
14	Clip - pump bulkhead		8 716 148 316 0		NG	■												
15	Pipe - primary flow		8 716 121 566 0		NG	■												
16	Primary flow manifold		8 716 141 221 0		NG	■												
17	Pressure relief valve 312438		8 716 142 404 0	23	NG	■												
18	Pipe - pressure releif		8 716 100 259 0		NG	■												BEFORE FD081
18	Pipe - pressure relief		8 716 101 319 0		NG	■												AFTER FD081
19	Pipe - gas inlet assembly		8 716 120 966 0		NG	■												
20	Gas valve 28i dungs		8 716 156 766 0		NG	■												
21	Burner manifold		8 716 143 001 0		NG	■												
22	Main burner injector set		8 716 140 208 0	20	NG	■												
23	Bypass assembly		8 716 121 578 0		NG	■												
24	Expansion vessel		8 716 142 502 0	41	NG	■												
25	Pipe - expansion vessel		8 716 100 604 0		NG	■												Version code: ARX
25	Pipe - expansion vessel		8 716 102 380 0		NG	■												Version code: ASK
26	Pipe - dom hot water out assy		8 716 102 360 0		NG	■												Version code: ARX
26	Pipe - dom hot water out assembly		8 716 120 970 0		NG	■												Version code: ASK
27	Central heating sensor (pps)		8 716 142 384 0	29	NG	■												
28	Clip - domestic h.w. thermistor		8 716 148 313 0		NG	■												
29	Primary h.w. thermistor clip		8 716 148 303 0	12	NG	■												
30	Primary flow elbow		8 716 101 318 0		NG	■												
31	Clamp spring		8 716 148 317 0	02	NG	■												
32	O-Ring 17.6 ID X 2.4 EP		8 716 140 820 0	02	NG	■												
33	Pipe - retainer		8 716 101 316 0		NG	■												
34	O-ring 7x2,5		8 716 140 817 0	22	NG	■												
35	Screw m4 x 8 hex hd brass		2 911 081 118 0		NG	■												
36	Fibre washer 23.9 X 17.2 X 1.5 (10x)		8 710 103 043 0	12	NG	■												
36	Washer 23.9 x 17.2 x 1.5 (X1)		8 716 115 674 0		NG	■												
37	Screw m5x10mm hex/slotted head		2 911 131 152 0	08	NG	■												
38	Wireform spring		8 716 148 310 0	17	NG	■												
39	Washer 18.6 X 13.5 X 1.5 (10x)		8 710 103 045 0	11	NG	■												
39	Washer 18.6 x 13.5 x 1.5 (1x)		8 716 115 680 0		NG	■												
40	Set of nuts		8 716 140 288 0	16	NG	■												
41	Screw iso no 6b x 9.5 recessed		2 912 421 210 0	07	NG	■												
42	Screw no.8x1/2 f/h type b self tap.		2 912 421 225 0	16	NG	■												
43	O-Ring 2.62x22.23 id h-nitrile		8 716 140 827 0		NG	■												
28i-FSN			Pump / Hydraulic assy D															1

Spare parts list

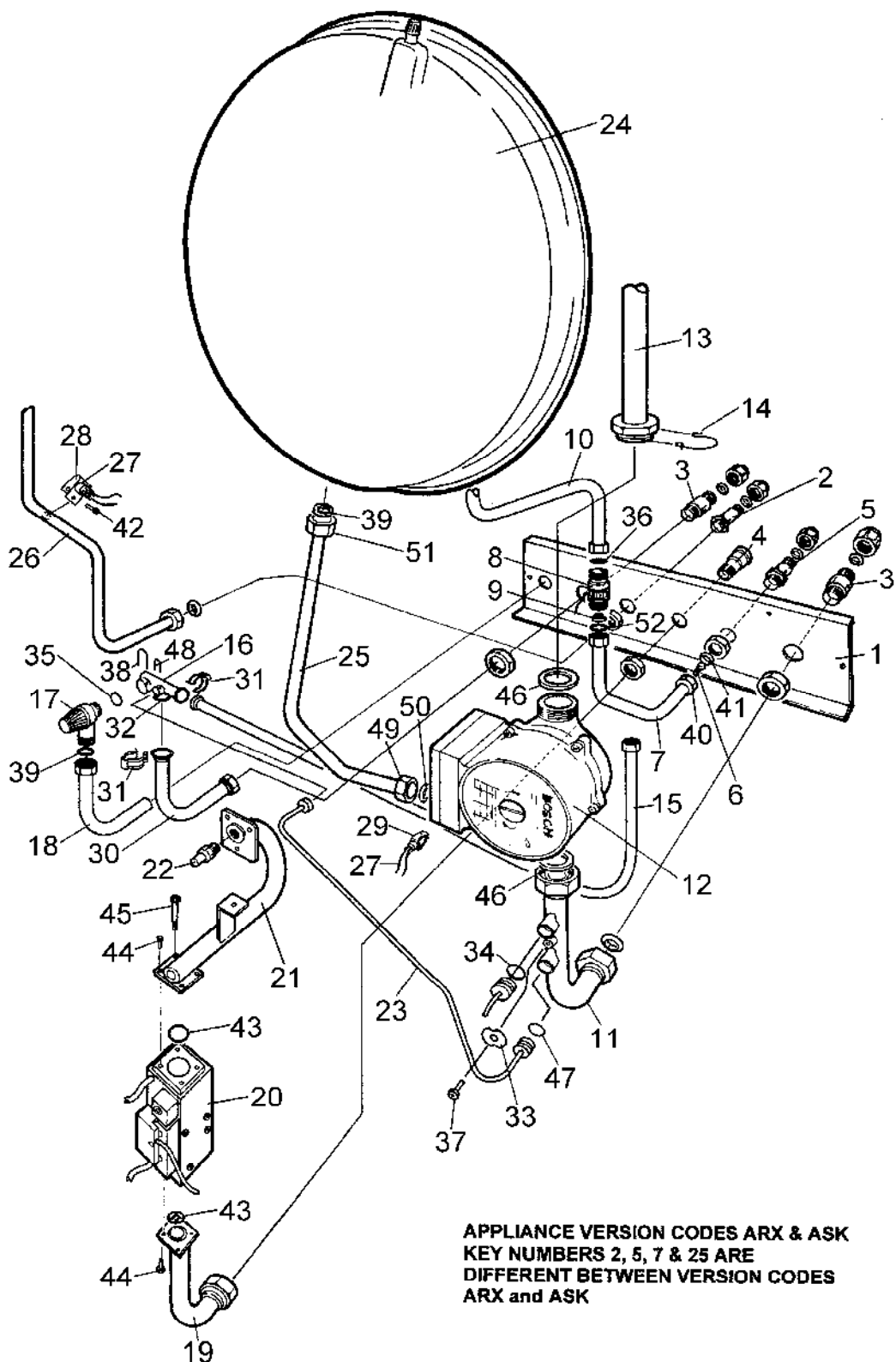

APPLIANCE VERSION CODES ARX & ASK
 KEY NUMBERS 2, 5, 7 & 25 ARE
 DIFFERENT BETWEEN VERSION CODES
 ARX and ASK

6720900089.AA

Pump / Hydraulic assy
 D

28I-FSN

1

Spare parts list

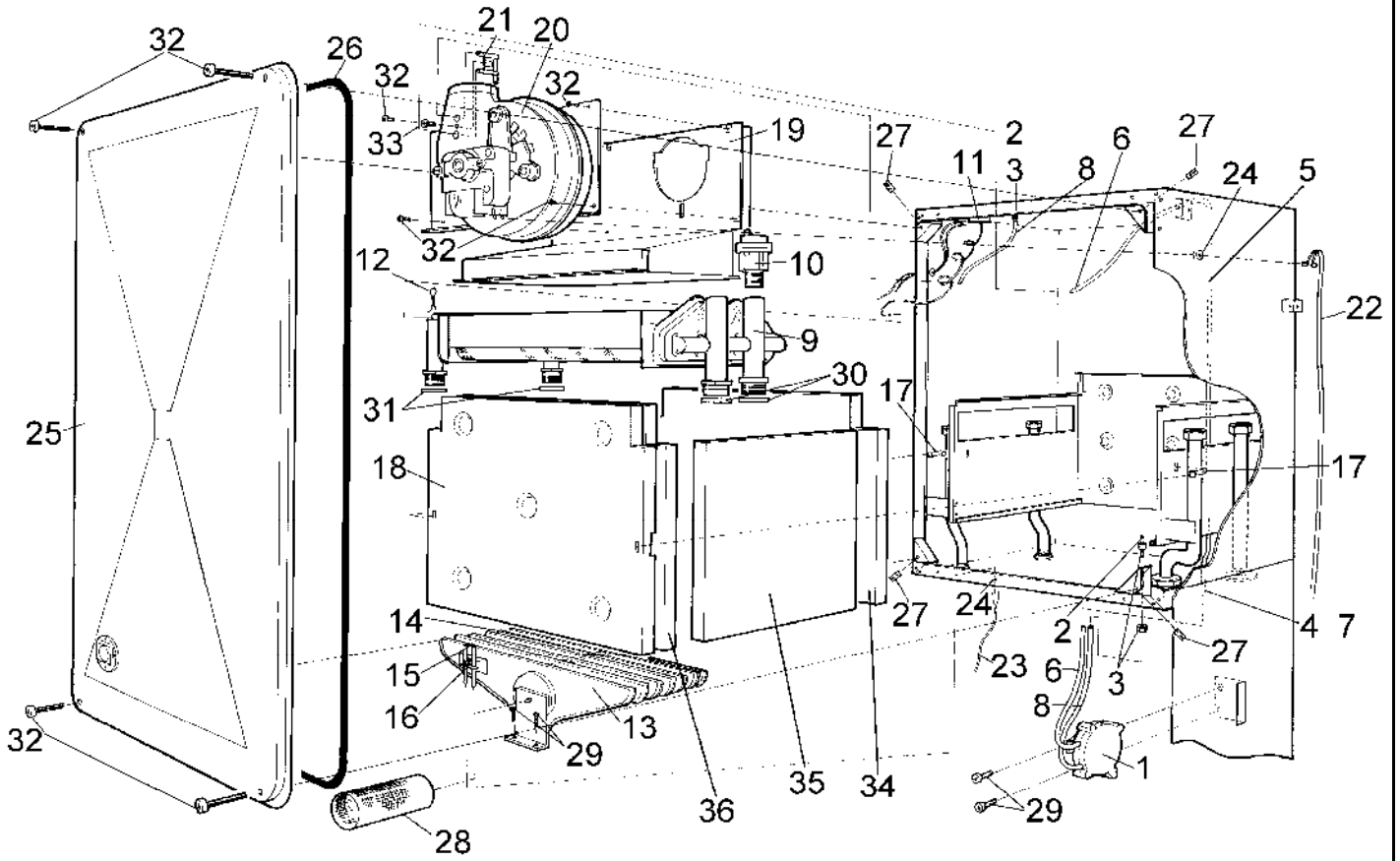

6720900090.AA

Superstructure
D

28I-FSN

2

Spare parts list

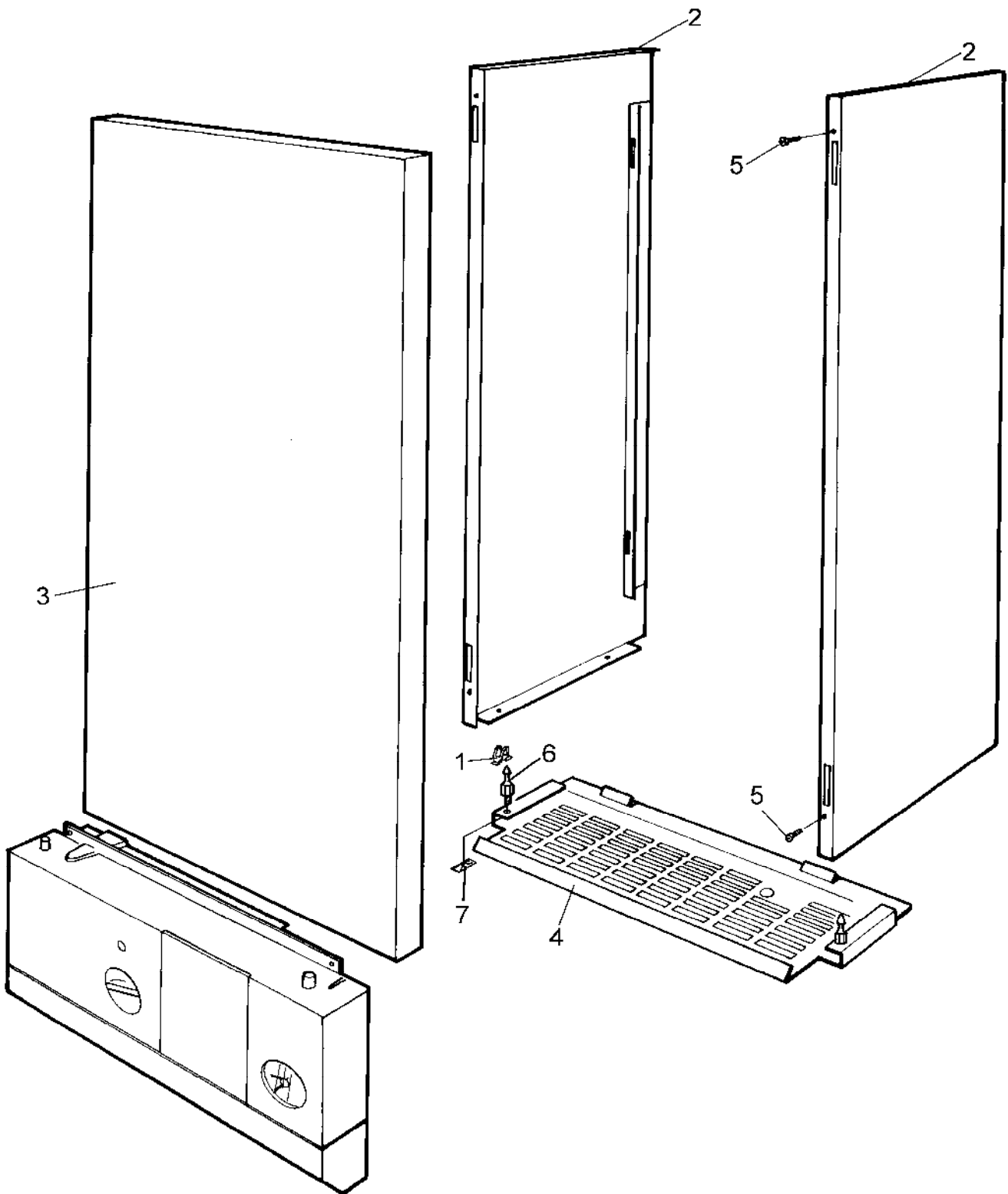

6720900087.AA

Casing
D

4

28I-FSN

**ADDITIONAL SPARE PARTS
FOR APPLIANCE
NOT DRAWN**

9099

6720900999.AA

Additional Spare Part
D

9

28I-FSN

List of translations

Pos				
1				
2				
3				
4				
5				
6				
7				
8				
9				
10				
11				
12				
13				
14				
15				
16				
17				
18				
19				
20				
21				
22				
23				
24				
25				
26				
27				
28				
29				
30				
31				
32				
33				
34				
35				
36				
37				
38				
39				
40				
41				
42				
43				
44				
45				
46				
47				
48				
49				
50				
51				
52				
2				
1				
2				
3				

List of translations

4				
5				
6				
7				
8				
9				
10				
11				
12				
13				
14				
15				
16				
17				
18				
19				
20				
21				
22				
23				
24				
25				
26				
27				
28				
29				
30				
31				
32				
33				
34				
35				
36				
3				
1				
2				
3				
4				
5				
6				
7				
8				
9				
10				
11				
12				
Pos				
4				
1				
2				
3				
4				
5				
6				
7				

