

ideal

VOGUE

SIMPLY ADVANCED



INSTALLATION AND SERVICING

COMBINATION BOILER
c26, c32, c40

When replacing any part on this appliance, use only spare parts that you can be assured conform to the safety and performance specification that we require. Do not use reconditioned or copy parts that have not been clearly authorised by Ideal. For the very latest copy of literature for specification and maintenance practices visit our website www.idealboilers.com where you can download the relevant information on PDF format.

For details of document amendments, refer to page 3

October 2013
UIN 208548 A04

NOTES FOR THE INSTALLER

**FOR ANY TECHNICAL QUERIES PLEASE RING THE
INSTALLER HELPLINE : 01482 498704**

NOTE. BOILER RESET PROCEDURE -

To reset boiler, press button "r" on the control panel. The boiler will repeat the ignition sequence if a heat demand is present

DOCUMENT AMENDMENTS

Relevant Installation changes implemented in this book from Mod Level A03 (May 13) to A04 (Sep 13)

Page 12 - Frame 5, Water Treatment

Addition of Adey Professional Heating Solutions

Page 31 - Frame 32, Commissioning and Testing

Electrical Installation - item no. 3 added

Page 40 - Frame 41, Menu Operation

Addition of Pump Modulation section

GENERAL

Table 1 - General Data

Vogue		26	32	40
Gas supply		2H - G20 - 20mbar		
Gas Supply Connection		22mm copper compression		
Injector Size	(mm)	4.30	4.40	5.15
Inlet Connection	Domestic Hot Water	15mm copper compression		
Outlet Connection	Domestic Hot Water	15mm copper compression		
Flow Connection	Central Heating	22mm copper compression		
Return Connection	Central Heating	22mm copper compression		
Flue Terminal Diameter	mm (in)	100 (4)		
Average Flue Temp-Mass Flow Rate (DHW)	°C (g/s)	73°C (11 g/s)	73°C (13 g/s)	70°C (17 g/s)
Maximum Working Pressure (Sealed Systems)	bar (lb/in ²)	2.5 (36.3)		
Maximum Domestic Hot Water Inlet Pressure	bar (lb/in ²)	10.0 (145)		
Minimum Domestic Hot Water Inlet Pressure*	bar (lb/in ²)	1.1 (16.0)	1.5 (21.8)	1.5 (21.8)
Electrical Supply		230 V ~ 50 Hz.		
Power Consumption	W	108	137	133
Fuse Rating		External : 3A Internal : 4A Time Delay		
Water content	Central Heating litre (gal)	1.5 (0.33)	1.8 (0.41)	2.2 (0.48)
	Domestic Hot Water litre (gal)	0.5 (0.11)		
Packaged Weight	kg (lb)	40.4 (89)	41.7 (92)	43.7 (96)
Maximum Installation Weight	kg (lb)	35.0 (77)	36.4 (80)	38.0 (84)
Boiler Casing Size	Height	740 (29.1)		
	Width	445 (17.5)		
	Depth	330 (13)		
Heat Exchanger Weight without Burner	KG	7.3	8.2	9.5

*Required for maximum flow rate. Boiler operates down to 2 l/min DHW delivery

** In areas of low water pressure the DHW restrictor can be removed

Table 2 - Performance Data - Central Heating

Boiler Input :		Max.			Min.		
		26	32	40	26	32	40
Boiler Input 'Q'	Nett CV	18.1	26.1	32.1	3.7	4.6	5.7
	kW (Btu/h)	61,800	89,100	109,500	12,700	15,600	19,500
Gross CV	kW	20.1	29.0	35.6	4.1	5.1	6.3
	(Btu/h)	68,500	98,800	121,600	14,100	17,300	21,600
Gas Consumption	m ³ /h	1.869	2.695	3.314	0.383	0.472	0.590
	(ft ³ /h)	66.0	95.2	117.1	13.6	16.7	20.8
Boiler Output :							
Non Condensing	kW	18.0	26.0	32.0	3.7	4.6	5.7
	70°C Mean Water temp. (Btu/h)	61,400	88,700	109,200	12,800	15,700	19,600
Condensing	kW	19.3	27.9	34.3	4.0	4.9	6.1
	40°C Mean Water temp. (Btu/h)	65,900	95,300	117,200	13,600	16,700	20,900
Seasonal efficiency* SEDBUK 2005		91.0	91.1	91.0	n/a		
Seasonal efficiency* SEDBUK 2009		89.1	89.2	89.1	n/a		
NOx Classification		Class 5					

Table 3 - Performance Data - Domestic Hot Water

Maximum DHW Input :		26	32	40
Nett CV	kW	26.1	32.1	40.2
	(Btu/h)	89,100	109,500	137,200
Gross CV	kW	29.0	35.6	44.6
	(Btu/h)	98,800	121,600	152,200
Gas Consumption	m ³ /h	2.695	3.314	4.150
	(ft ³ /h)	95.2	117.1	146.6
Maximum DHW Output	kW (Btu/h)	26.0 (88,700)	32.0 (109,200)	40.0 (136,500)
DHW Flow Rate at 35°C temp. rise.	l/min	10.6	13.1	16.4
	(gpm)	2.3	2.9	3.6
DHW Specific Rate	l/min	12.4	15.3	19.1
	(gpm)	2.7	3.4	4.2

* The value is used in the UK Government's Standard Assessment Procedure (SAP) for energy rating of dwellings. The test data from which it has been calculated have been certified by a notified body.

Note. Gas consumption is calculated using a calorific value of 38.7 MJ/m³ (1038 Btu/ft³) gross or 34.9 MJ/m³ (935 Btu/ft³) nett

To obtain the gas consumption at a different calorific value:

- For l/s - divide the gross heat input (kW) by the gross C.V. of the gas (MJ/m³)
- For ft³/h - divide the gross heat input (Btu/h) by the gross C.V. of the gas (Btu/ft³)
- For m³/h - multiply l/s by 3.6

Key to symbols

GB = United Kingdom **IE** = Ireland (Countries of destination)

PMS = Maximum operating pressure of water

C₁₃ C₃₃ C₅₃* = A room sealed appliance designed for connection via ducts to a horizontal or vertical terminal, which admits fresh air to the burner and discharges the products of combustion to the outside through orifices which, in this case, are concentric. The fan is up stream of the combustion chamber. (*Note. **C₅₃** covers optional high level and balcony flue kits only.)

I_{2H} = An appliance designed for use on 2nd Family gas, Group H only.

GENERAL

Vogue Natural Gas only

Boiler size	G.C. Appliance No. (Benchmark No.)	PI No.
26	47-348-99	86 CN 45
32	47-348-98	86 CN 45
40	47-348-97	86 CN 45

Destination Country: GB, IE

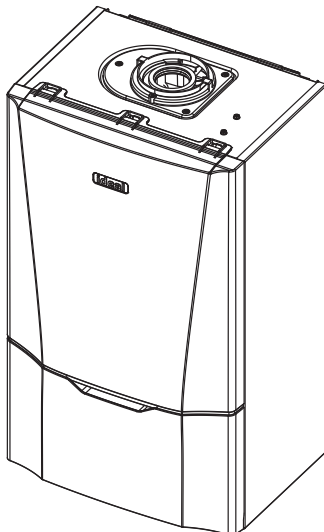

CONTENTS

Air Supply	9
Benchmark Commissioning Checklist	70
Boiler Clearances	10
Boiler Exploded Diagram	13
Condensate Drain	9, 21, 22, 46
Electrical Connections	32
Electrical Supply	9
Fault Finding	60-66
Flue Fitting	16
Flue Installation	16-25
Gas Safety Regulations	7
Gas Supply	8
Installation	13-42
Pump	55
Safe Handling	6
Servicing	43-59
Thermostatic Radiator Valves	9
Water and Systems	9,11,12
Water & Gas Connections	26
Water Treatment	12
Wiring Diagram	30

For GB, to comply with Building Regulations Part L1 (Part 6 in Scotland) the boiler should be fitted in accordance with the manufacturer's instructions. Self-certification that the boiler has been installed to comply with Building Regulations can be demonstrated by completing and signing the Benchmark Commissioning Checklist.

Before installing this boiler, read the Code of Practice sheet at the rear of this book.

BENCHMARK COMMISSIONING CHECKLIST DETAILS

Boiler	Page	Page
Make and model.....	5	Burner operating pressure
Appliance serial no. on data badge	Front Cover	Central heating flow temp.
SEDBUK No. %.....	4	Central heating return temp.
Controls		For combination boilers only
Time and temperature control to heating	29	Scale reducer
Time and temperature control to hot water	29	<i>Hot water mode</i>
Heating zone valves.....	n/a	Heat input.....
TRV's.....	9	Max. operating burner pressure
Auto bypass	9	Max. operating water pressure.....
Boiler interlock.....	9	Cold water inlet temp
For	all boilers	Hot water outlet temp
Flushing to BS.7593.....	12	Water flow rate at max. setting.....
Inhibitor	12	For condensing boilers only
<i>Central heating mode</i>		Condensate drain.....
Heat input.....	to be calculated	For all boilers: <i>complete, sign & hand over to customer</i>

For assistance see Technical Helpline on the back page

NOTE TO THE INSTALLER: COMPLETE THE BENCHMARK COMMISSIONING CHECKLIST AND LEAVE THESE INSTRUCTIONS WITH APPLIANCE



INTRODUCTION

The **Vogue** range of boilers are wall mounted, full sequence, automatic spark ignition, low water content, fanned flue, high efficiency, condensing, combination gas boilers.

Note. *Due to the high efficiency of the boiler a plume of water vapour will form at the terminal during operation.*

Central heating (CH) output is fully modulating with a range of:

26 3.7 to 18.0kW (12,800 to 61,400 Btu/h)

32 4.6 to 26.0kW (15,700 to 88,700 Btu/h)

40 5.7 to 32.0kW (19,600 to 109,200 Btu/h)

Instantaneous domestic hot water (DHW) output is also fully modulating with a maximum of :

26 26kW (88,700 Btu/h)

32 32kW (109,200 Btu/h)

40 40kW (136,500 Btu/h)

The boiler is supplied fully assembled with DHW plate heat exchanger, diverter valve, circulating pump, pressure gauge, pressure relief valve and CH expansion vessel.

Variable CH and DHW temperature controls are fitted on the user control and the boiler features a DHW preheat facility.

The boiler includes as standard:

- Automatic bypass
- Boiler frost protection
- Daily pump and diverter valve exercise.

The boiler casing is of white painted mild steel with a white polymer front panel.

The boiler temperature controls are located behind the lower panel on the front of the boiler.

The heat exchanger is manufactured from stainless steel.

The boiler is suitable for connection to fully pumped, sealed heating systems ONLY. Adequate arrangements for completely draining the system by provision of drain cocks MUST be provided in the installation pipework.

The standard configuration of pipework from the boiler is routed downwards.

OPERATION

With no demand for CH, the boiler fires only when DHW is drawn off, or periodically for a few seconds without any DHW draw-off, in order to maintain the DHW calorifier in a heated condition. This only occurs if pre-heat is selected from the menu.

When there is a demand for CH, the heating system is supplied at the selected temperature of between 30°C and 80°C, until DHW is drawn off. The full output from the boiler is then directed via the diverter valve to the plate heat exchanger to supply a nominal DHW draw-off of

26 10.6 l/min at 35 °C temperature rise.

32 13.1 l/min at 35 °C temperature rise.

40 16.4 l/min at 35 °C temperature rise.

The DHW draw off rate specified above is the nominal that the boiler flow regulator will give. Due to system variations and seasonal temperature fluctuations DHW flow rates/temperature rise will vary, requiring adjustment at the draw off tap.

At low DHW draw-off rate the maximum temperature is limited to 65 °C by the modulating gas control.

The boiler features a comprehensive diagnostic system which gives detailed information on the boiler status when operating, and performance of key components to aid commissioning and fault finding.

SAFE HANDLING

This boiler may require 2 or more operatives to move it to its installation site, remove it from its packaging base and during movement into its installation location. Manoeuvring the boiler may include the use of a sack truck and involve lifting, pushing and pulling.

Caution should be exercised during these operations.

Operatives should be knowledgeable in handling techniques when performing these tasks and the following precautions should be considered:

- Grip the boiler at the base.
- Be physically capable.
- Use personal protective equipment as appropriate, e.g. gloves, safety footwear.

During all manoeuvres and handling actions, every attempt should be made to ensure the following unless unavoidable and/or the weight is light.

- Keep back straight.
- Avoid twisting at the waist.
- Avoid upper body/top heavy bending.
- Always grip with the palm of the hand.
- Use designated hand holds.
- Keep load as close to the body as possible.
- Always use assistance if required.

OPTIONAL EXTRA KITS

- **Horizontal Flue Terminal** (600mm long)
- **Horizontal Flue Terminal** (1000mm long)
- **Flue Extension Ducts** (1000mm long)
 - 26-up to 10m
 - 32-up to 8m
 - 40-up to 8m
- **Flue Finishing Kit**
- **90° Elbow Kit** (maximum per installation)
 - 26 - upto 6 elbows
 - 32 - upto 4 elbows
 - 40 - upto 4 elbows
- **45° Elbow Kit** (maximum per installation)
 - 26 - upto 6 elbows
 - 32 - upto 4 elbows
 - 40 - upto 4 elbows
- **Roof Flue Kit** (to a maximum of 10m)
- **Flue Vertical Connector Kit**
- **Raised Horizontal Flue Outlet Kit**
- **Flue Extension Kit Ø60 (1m)**
- **Concentric Flue Screw Retaining Kit**
- **Weather Collar**
- **Stand-Off Kit**
- **Stand-Off Kit (inc. pipes)**
- **High Level Flue Outlet Kit**
- **Flue Deflector Kit**
- **Condensate Pump Kit**
- **Mechanical Timer (24 hr) Kit**
- **Electronic Timer (7 day) kit**
- **RF Mechanical Programmable Room Thermostat (24 hr) kit**
- **RF Electronic Programmable Room Thermostat (7 day) kit**
- **Weather Compensation Kit**
- **Adjustable Flue Support Bracket**
- **DHW Expansion Vessel Kit**
- **Balcony Flue Kit**
- **Security Bracket Kit**
- **Flue Support Bracket Kit**

SAFETY

Current Gas Safety (installation and use) regulations or rules in force:

The appliance is suitable only for installation in GB and IE and should be installed in accordance with the rules in force.

In GB, the installation must be carried out by a Gas Safe Registered Engineer. It must be carried out in accordance with the relevant requirements of the:

- Gas Safety (Installation and Use) Regulations
- The appropriate Building Regulations either The Building Regulations, The Building Regulations (Scotland), Building Regulations (Northern Ireland).
- The Water Fittings Regulations or Water byelaws in Scotland.
- The Current I.E.E. Wiring Regulations.

Where no specific instructions are given, reference should be made to the relevant British Standard Code of Practice.

In IE, the installation must be carried out by a Registered Gas Installer (RGI) and installed in accordance with the current edition of I.S.813 "Domestic Gas Installations", the current Building Regulations and reference should be made to the current ETCI rules for electrical installation.

Detailed recommendations are contained in the following British Standard Codes of Practice:

- BS. 5440:1** Flues (for gas appliances of rated input not exceeding 70 kW).
- BS. 5440:2** Ventilation (for gas appliances of rated input not exceeding 70 kW).
- BSEN. 12828:2003** Heating Systems in buildings: Design for water based heating systems.
- BSEN 12831:2003** Heating Systems in buildings: Method for calculation of the design heat load.
- BSEN 14336:2004** Heating Systems in buildings: Installation and commissioning of water based heating systems.
- BS. 5546** Installation of gas hot water supplies for domestic purposes (2nd Family Gases)
- BS. 6798** Installation of gas fired hot water boilers of rated input not exceeding 70 kW.
- BS. 6891** Low pressure installation pipes.

Health & Safety Document No. 635.

The Electricity at Work Regulations, 1989.

The manufacturer's notes must NOT be taken, in any way, as overriding statutory obligations.

IMPORTANT. These appliances are CE certificated for safety and performance. It is, therefore, important that no external control devices, e.g. flue dampers, economisers etc., are directly connected to these appliances unless covered by these Installation and Servicing Instructions or as otherwise recommended by **Ideal Stelrad Group** in writing. If in doubt please enquire.

Any direct connection of a control device not approved by **Ideal Stelrad Group** could invalidate the certification and the normal appliance warranty. It could also infringe the Gas Safety Regulations and the above regulations.

SAFE HANDLING OF SUBSTANCES

No asbestos, mercury or CFCs are included in any part of the boiler or its manufacture.

GENERAL

5. The flue assembly shall be so placed or shielded as to prevent ignition or damage to any part of any building.
6. The air inlet/products outlet duct and the terminal of the boiler MUST NOT be closer than 25mm (1") to combustible material. Detailed recommendations on the protection of combustible material are given in BS. 5440-1:2008.

IMPORTANT. It is essential to ensure, in practice, that products of combustion discharging from the terminal cannot re-enter the building or buildings through any openings into the building such as ventilators, windows, doors, or other sources of natural air infiltration, such as forced ventilation openings etc.

If products of combustion re-entry is identified or suspected this should be immediately investigated and corrected following the guidance provided in the current Gas Industry Unsafe Situation Procedure.

Table 4 - Balanced Flue Terminal Position

Flue Terminal Positions	Min. Spacing*
1. Directly below, above or alongside an opening window, air vent or other ventilation opening.	300mm (12")
2. Below guttering, drain pipes or soil pipes. <i>BS5440-1 2008</i>	25mm (1")* 75mm (3")
3. Below eaves. <i>BS5440-1 2008</i>	25mm (1")* 200mm (8")
4. Below balconies or a car port roof. <i>BS5440-1 2008</i>	25mm (1")* 200mm (8")
5. From vertical drain pipes or soil pipes. <i>BS5440-1 2008</i>	25mm (1")* 150mm (6")
6. From an internal or external corner or to a boundary along side the terminal. <i>BS5440-1 2008</i>	25mm (1")* 300mm (12")
7. Above adjacent ground, roof or balcony level.	300mm (12")
8. From a surface or a boundary facing the terminal.	600mm (24")
9. From a terminal facing a terminal.	1,200mm (48")
10. From an opening in a car port (e.g. door or window) into dwelling.	1,200mm (48")
11. Vertically from a terminal on the same wall.	1,500mm (60")
12. Horizontally from a terminal on the wall.	300mm (12")
Vertical Terminals	
13. Above the roof pitch with roof slope of all angles. Above flat roof.	300mm (12") 300mm (12")
14. From a single wall face. From corner walls.	300mm (12") 300mm (12")
15. Below velux window	2000mm (79")
16. Above or side of velux window	600mm (24")

* Only one reduction down to 25mm is allowable per installation otherwise BS5440-1 2008 dimensions must be followed.

TERMINAL

The terminal assembly can be adapted to accommodate various wall thicknesses. Refer to Frame 10 .

AIR SUPPLY

It is NOT necessary to have a purpose-provided air vent in the room or internal space in which the boiler is installed. Neither is it necessary to ventilate a cupboard or compartment in which the boiler is installed, due to the low surface temperatures of the boiler casing during operation; therefore the requirements of BS 6798, Clause 12, and BS 5440:2 may be disregarded.

WATER CIRCULATION SYSTEM

IMPORTANT.

A minimum length of 1 metre of copper pipe MUST be fitted to both flow and return connections from the boiler before connection to any plastic piping.

The central heating system should be in accordance with BS.6798 and, in addition, for smallbore and microbore systems, BS.5449.

WATER TREATMENT - see Frame 5

BOILER CONTROL INTERLOCKS

Central heating systems controls should be installed to ensure the boiler is switched off when there is no demand for heating, in compliance with Building Regulations.

Heating systems utilising full thermostatic radiator valve control of temperature in individual rooms should also be fitted with a room thermostat controlling the temperature in a space served by radiators not fitted with such a valve.

When thermostatic radiator valves are used, the space heating temperature control over a living / dining area or hallway having a heating requirement of at least 10% of the minimum boiler heat output should be achieved using a room thermostat, whilst other rooms are individually controlled by thermostatic radiator valves. However, if the system employs thermostatic radiator valves on all radiators, or two port valves, then a bypass circuit external to the boiler must be fitted with an automatic bypass valve to ensure a flow of water should all valves be in the closed position.

ELECTRICAL SUPPLY

WARNING.

This appliance must be earthed.

Wiring external to the appliance MUST be in accordance with the current I.E.E. (BS.7671) Wiring Regulations and any local regulations which apply. For IE reference should be made to the current ETCI rules for electrical installations.

The mains supply to the boiler and system wiring centre shall be through one common fused double pole isolator and for new heating systems, and where practical replacement installations, the isolator shall be situated adjacent to the appliance.

CONDENSATE DRAIN

Refer to Frames 22, 23 & 54

A condensate drain is provided on the boiler. This drain must be connected to a drainage point on site. All pipework and fittings in the condensate drainage system MUST be made of plastic - *no other materials may be used.*

IMPORTANT.

Installation must be in accordance with BS 6798.

The drain outlet on the boiler is sized for standard 21.5mm (3/4") overflow pipe. It is a universal fitting to allow use of different brands of pipework.

GENERAL

1 BOILER DIMENSIONS, SERVICES & CLEARANCES

all dimensions in mm

The boiler connections are made on the boiler connection tails. Refer to Frame 24.

The following minimum clearances must be maintained for operation and servicing.

Additional space will be required for installation, depending upon site conditions.

Side and Rear Flue

a. Provided that the flue hole is cut accurately, e.g. with a core drill, the flue can be installed from inside the building where

wall thicknesses do not exceed 600mm (24"). Where the space into which the boiler is going to be installed is less than the length of flue required the flue must be fitted from the outside.

Installation from inside ONLY

b. If a core boring tool is to be used inside the building the space in which the boiler is to be installed must be at least wide enough to accommodate the tool.

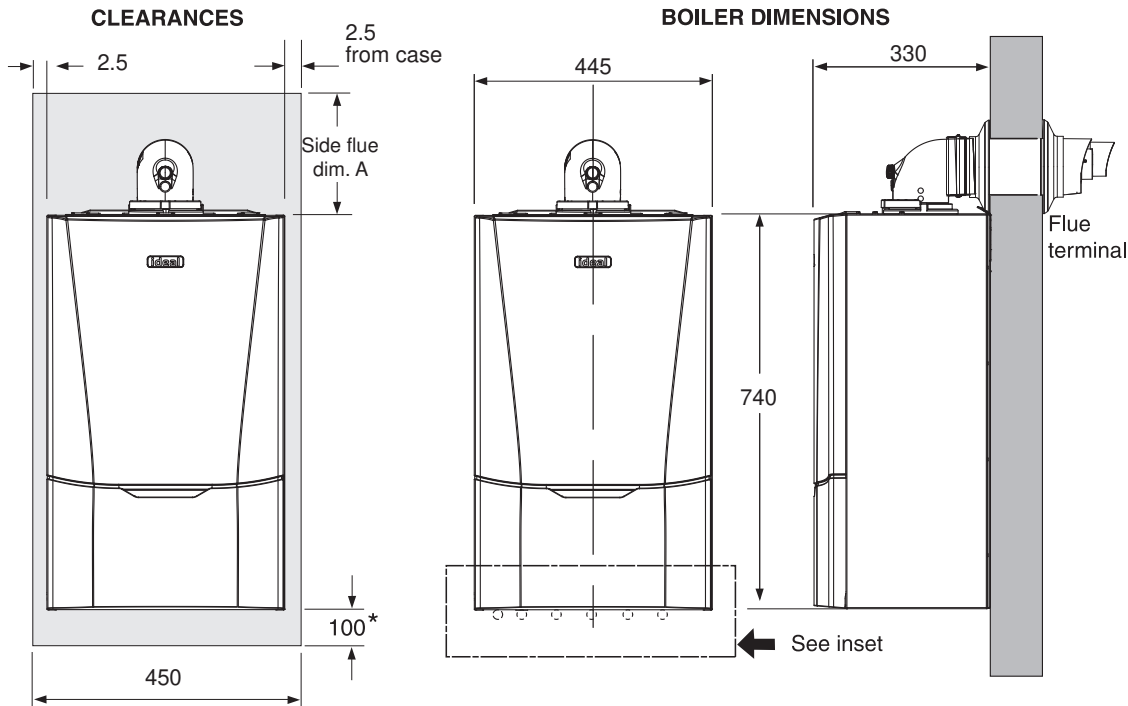

Inset: Water Connections and Gas Connection

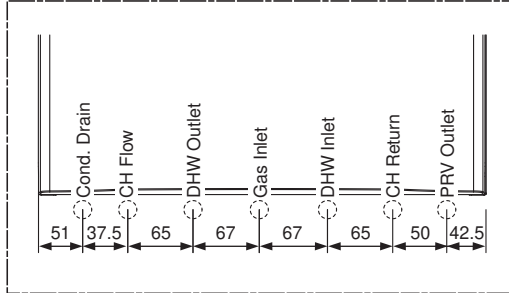

Front clearance

The minimum front clearance when built in to a cupboard is 5mm from the cupboard door but 450mm overall clearance is still required, with the cupboard door open, to allow for servicing.

* Bottom clearance

Bottom clearance after installation can be reduced to 5mm. This must be obtained with an easily removable panel, to enable the consumer to access the filling loop, and to provide the 100mm clearance required for servicing..

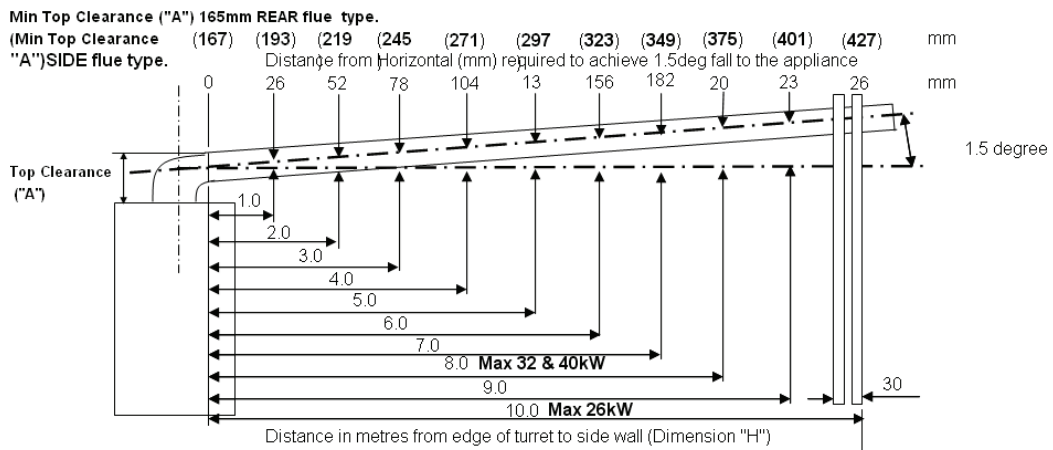

1. If the wall thickness is greater than 305mm then dimension "H" must be reduced by the difference in wall thickness.
2. For flue lengths requiring "D" pack extensions the flue must incline by 26mm per 1 Metre of flue length. No flue length greater than the maximum flue length shown above should be exceeded.

GENERAL

2 SYSTEM REQUIREMENTS - Central Heating

Notes

- a. The method of filling, refilling, topping up or flushing sealed primary hot water circuits from the mains via a temporary hose connection is only allowed if acceptable to the local water authority.
- b. Antifreeze fluid, corrosion and scale inhibitor fluids suitable for use with boilers having stainless steel heat exchangers may be used in the central heating system.

General

1. The installation must comply with all relevant national and local regulations.
2. The installation should be designed to work with flow temperatures of up to 86 °C.
3. All components of the system must be suitable for a working pressure of 3 bar and temperature of 110 °C. Extra care should be taken in making all connections so that the risk of leakage is minimised.

The following components are incorporated within the appliance:

- a. Circulating pump.
- b. Pressure relief valve, with a non-adjustable preset lift pressure of 3 bar.
- c. Pressure gauge, covering a range of 0 to 4 bar.
- d. A 10-litre expansion vessel, with an initial charge pressure of 0.75 bar.

4. 'Make-up' Water

The water connection and isolation valves incorporate an approved system for filling and topping up the water in the heating system. Refer to Frame 24 for details of how to fill and top up the system.

The maximum cold water capacity of the system should not exceed 159 litres, if not pressurized. However, if the system is to be pressurized, the efficiency of the expansion vessel will be reduced and a larger vessel (or smaller system volume) may be necessary. If the capacity of the vessel is not considered sufficient for this, or for any other reason, an additional vessel MUST be installed on the return to the boiler.

Guidance on vessel sizing is given in Table above.

5. Filling

The system may be filled by the following method:

Where the mains pressure is excessive a pressure reducing valve must be used to facilitate filling.

Pressure relief valve setting	bar	3.0	
Vessel charge pressure	bar	0.5 to 0.75	
System pre-charge pressure	bar	None	1.0
System volume (litres)		Expansion vessel volume (litres)	
	25	1.6	1.8
	50	3.1	3.7
	75	4.7	5.5
	100	6.3	7.4
	125	7.8	9.2
	150	9.4	11.0
	175	10.9	12.9
	190	11.9	14.0
	200	12.5	14.7
	250	15.6	18.4
	300	18.8	22.1
For other system volumes multiply by the factor across		0.063	0.074

Model		26	32	40
Max CH output	kW	18	26	32
	Btu/h	61400	88700	109200
Water flow rate @ 20°C differential	l/min	13	18.6	22.9
	gal/min	2.9	4.1	5.0
Head available for system	m.wg	4.4	2.5	1.2
	ft.wg	14.4	8.2	3.9

- a. Thoroughly flush out the whole system with cold water.
- b. Fill and vent the system until the pressure gauge registers 1bar and examine for leaks. Refer to Frame 24 for filling detail.
- c. Check the operation of the safety valve by raising the water pressure until the valve lifts. This should occur within 0.3bar of the preset lift pressure.
- d. Release water from the system until the minimum system design pressure is reached; 1.0 bar if the system is to be pre-pressurised.

continued

GENERAL

3 SYSTEM REQUIREMENTS - (continued)

DOMESTIC HOT WATER

1. The domestic hot water service must be in accordance with BS 5546 and BS 6700.
2. Refer to Table 1 for minimum and maximum working pressures. In areas of low mains water pressures the domestic hot water regulator may be removed from the DHW flow turbine cartridge. Refer to Frame 76. The boiler will require the flow rate to be set to obtain a temperature rise of 35°C at the tap furthest from the boiler.
3. The boilers are suitable for connection to most types of washing machine and dishwasher appliances.
4. When connecting to suitable showers, ensure that:
 - a. The cold inlet to the boiler is fitted with an approved anti-vacuum or syphon non-return valve.
 - b. Hot and cold water supplies to the shower are of equal pressure.
5. **Hard Water Areas**
Where the water hardness exceeds 200mg/litre (200ppm), it is recommended that a proprietary scale reducing device is fitted into the boiler cold supply within the requirements of the local water company.

IMPORTANT. Provision must be made to accommodate the expansion of DHW contained within the appliance. If the DHW inlet contains a back flow prevention device or non-return valve, e.g. a water meter, then a mini expansion vessel should be fitted between the device and the boiler in the cold inlet pipe.

Cold water, rising main & pipework in exposed areas need to be suitably lagged to prevent freezing.

Note. DHW Expansion Vessel kit available from Ideal.

4 SYSTEM BALANCING

The boiler does not normally need a bypass but at least some radiators on the heating circuit, of load of at least 10% of the minimum boiler output, must be provided with twin lockshield valves so that this minimum heating load is always available. See note regarding thermostatic radiator valves on page 9.

Note. *Systems incorporating zone valves which could completely cut off the flow through the system must also include a bypass.*

BALANCING

1. Set the programmer to ON.
Close the manual or thermostatic valves on all radiators, leaving the twin lockshield valves (on the radiators referred to above) in the OPEN position.
Turn up the room thermostat and adjust the lockshield valve to give an uninterrupted flow through the radiator.
These valves should now be left as set.
2. Open all manual or thermostatic radiator valves and adjust the lockshield valves on the remaining radiators, to give around 20°C temperature drop at each radiator.
3. Adjust the room thermostat and programmer to NORMAL settings.

5 WATER TREATMENT

CENTRAL HEATING

The Vogue range of boilers have a stainless steel heat exchanger.

IMPORTANT.

The application of any other treatment to this product may render the guarantee of Ideal Stelrad Group Invalid.

Ideal Stelrad Group recommend Water Treatment in accordance with the Benchmark Guidance Notes on Water Treatment in Central Heating Systems.

If water treatment is used **Ideal Stelrad Group** recommend only the use of SCALEMASTER GOLD 100, FERNOX, MBI, ADEY MC1 or SENTINEL X100 inhibitors and associated water treatment products, which must be used in accordance with the manufacturers' instructions.

Notes.

1. *It is most important that the correct concentration of the water treatment products is maintained in accordance with the manufacturers' instructions.*
2. *If the boiler is installed in an existing system any unsuitable additives MUST be removed by thorough cleansing. BS 7593:2006 details the steps necessary to clean a domestic heating system.*
3. *In hard water areas, treatment to prevent lime scale may be necessary - however the use of artificially softened water is NOT permitted.*
4. *Under no circumstances should the boiler be fired before the system has been thoroughly flushed.*

DOMESTIC HOT WATER

In hard water areas where mains water can exceed 200ppm Total Hardness (as defined by BS 7593:2006 Table 2) a scale reducing device should be fitted into the boiler cold supply within the requirements of the local water company. The use of artificially softened water, however, is not permitted.

Ideal Stelrad Group recommend the use of Fernox Quantomat, Sentinel Combiguard and Calmag CalPhos I scale reducing devices or Scalemaster Inline Scale Inhibitor branded Ideal, which must be used in accordance with the manufacturers' instructions.

For further information contact:

Fernox Cookson Electronics
Forsyth Road, Sheerwater, Woking, Surrey GU21 5RZ
+44 (0) 8706 015000

Sentinel Performance Solutions
The Heath Business & Technical Park
Runcorn, Cheshire WA7 4QX
Tel: 0800 389 4670

Scalemaster Water Treatment Products
Emerald Way, Stone, Staffordshire ST15 0SR
Tel: +44 (0) 1785 811636

Calmag Ltd.
Unit 3-6, Crown Works, Bradford Road,
Sandbeds, Keighley, West Yorkshire BD20 5LN
Tel: +44 (0) 1535 210320

Adey Professional Heating Solutions
Gloucester Road, Cheltenham GL51 8NR
Tel: +44 (0) 1242 546700

INSTALLATION

6 BOILER ASSEMBLY - Exploded View

Note that item numbers are linked to the spares list

- 104 CH Return Valve
- 105 CH Flow Valve
- 106 DHW Outlet
- 107 Filling Loop
- 108 Pump Head
- 111 Divertor Valve Head
- 112 Divertor Valve Cartridge
- 113 Pressure Relief Valve
- 114 Pipe - PRV Outlet
- 115 Pipe - Flow
- 116 Pipe - Return
- 117 Pipe - Expansion Vessel
- 118 Expansion Vessel

- 119 Return Group Manifold
- 120 Flow Group Manifold
- 121 Plate Heat Exchanger
- 123 Flow Sensor Hall Effect
- 124 Flow Turbine Cartridge
- 125 Water Pressure Transducer
- 127 Pressure Gauge
- 203 Pipe - Gas Inlet
- 204 Gas Valve
- 205 Injector - Gas
- 207 Venturi
- 208 Fan
- 209 Gasket - Fan/Venturi

- 210 Fan Adaptor
- 211 Venturi Deflector
- 212 Condensate Hose
- 213 Flue Turret Clamp
- 214 Siphon trap
- 218 Flue Manifold
- 219 Flue Manifold Seal
- 220 Fan Adaptor Seal
- 302 Primay PCB
- 303 CUI Board
- 304 Thermistor (Flow & Return)
- 306 Electrode Ignition
- 307 Electrode Detection

- 308 Ignitor Unit
- 317 Control Box Front
- 318 Control Box Lid
- 319 Programmer Blank Insert
- 320 Control Box Complete
- 321 Control Box Hinges
- 401 Heat Engine
- 403 Heat Engine Gasket
- 404 Burner Door
- 501 Front Panel/Door
- 503 Wall Mounting Plate
- 504 Bracket - Ignition

* Note that production boiler PCBs are factory pre-set to operate for boiler range and output, but when ordering Primary PCB as a spare, an additional Boiler Chip Card (BCC) MUST also be purchased for your specific boiler range and output.

Check boiler serial letter code on data plate to obtain correct BCC.

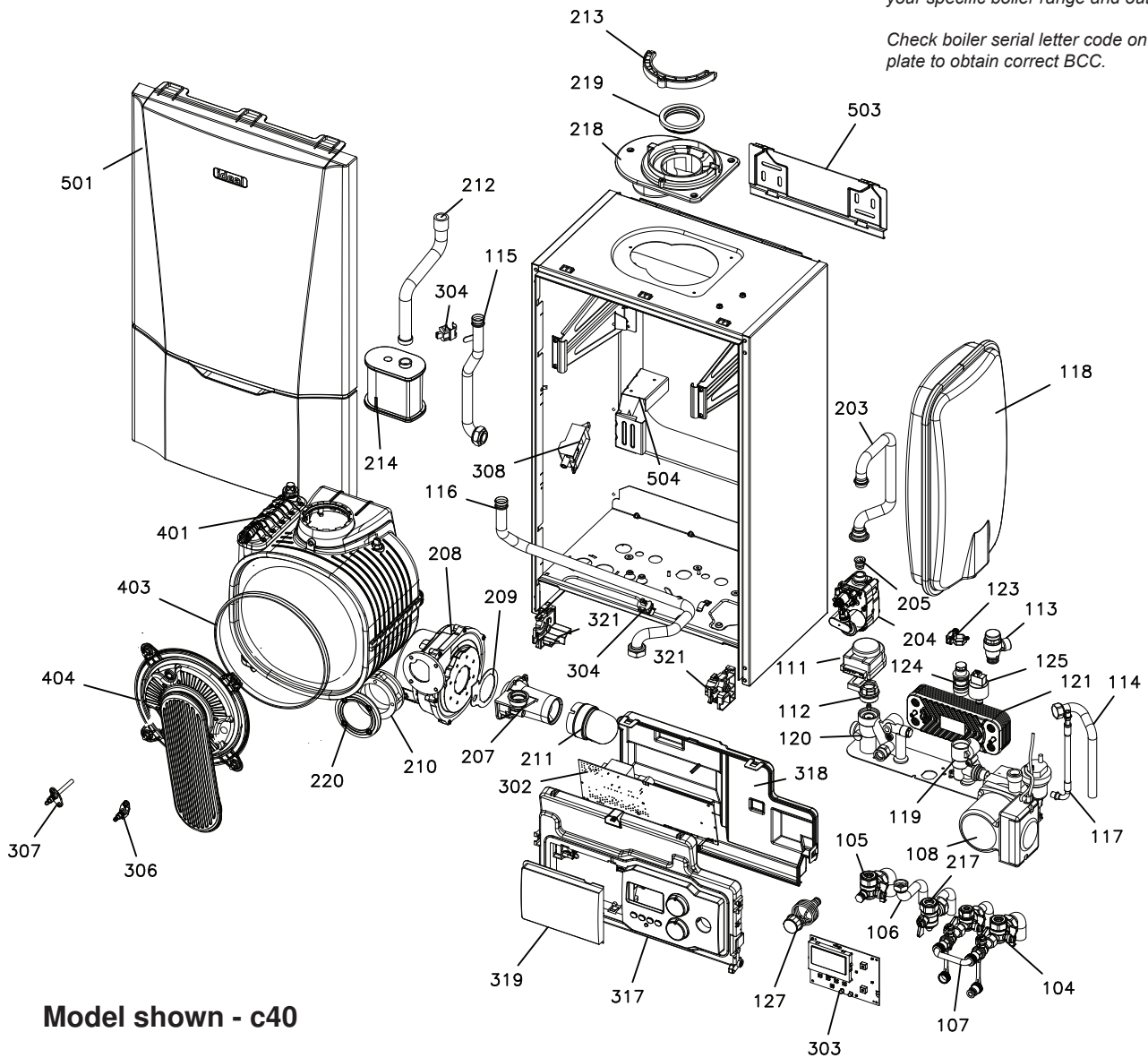

Model shown - c40

INSTALLATION

INSTALLATION

7 UNPACKING

The boiler is supplied fully assembled in Pack A. A telescopic or non-telescopic flue assembly for rear or side flue outlet, in Pack B is supplied as a separate order.

Unpack and check the contents.

Pack A Contents

- A Boiler
- B Hardware Pack Box
- C Wall Mounting Plate
- D These Installation Instructions
- E Wall Mounting Template (located on internal protective packaging)
- F Turret Clamp
- G Pressure Relief Valve Drain Pipe
- H Boiler Guarantee & Registration Pack

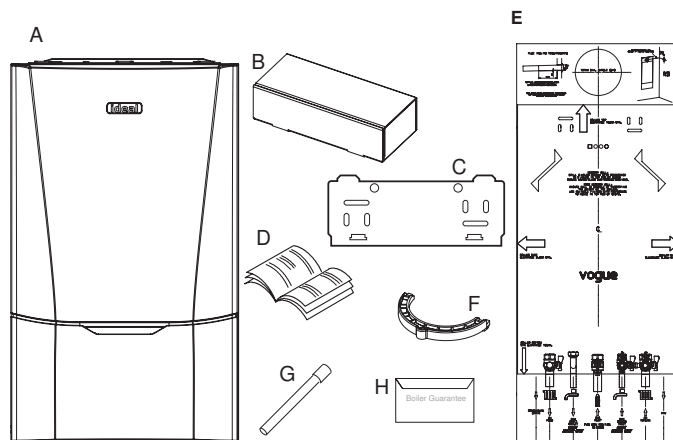

HARDWARE PACK CONTENTS

Gas Valve Pack

1. Pipe - Gas Inlet
2. Washer - Gas (blue)
3. Gas Cock

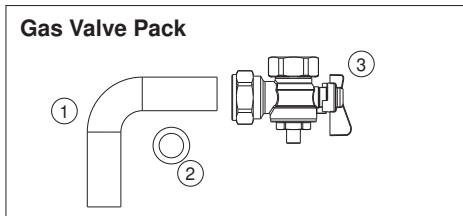

Filling Loop Pack

1. 3/8" Top Hat Washer (x2)
2. Plastic Chain (x2)
3. 3/8" Blanking Cap (x1)
4. Valve - Dbl Check Filling Loop (x1)
5. 3/8" Fibre Washer (x2)
6. 3/8" Blanking Cap Extended (x1)
7. Valve Filling Loop (x1)
8. Filling Loop with 3/8" Nuts (x1)

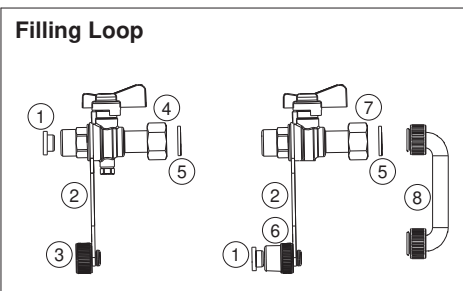

Return Valve Pack

1. Pipe CH Return
2. Washer CH
3. Valve Return

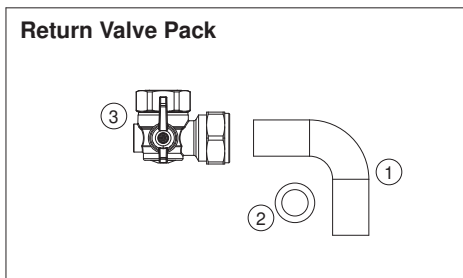

DHW Pack

1. Pipe DHW Inlet
2. Valve - Return DHW
3. Washer DHW (x2)
4. Pipe DHW Outlet
5. Nut 1/2"

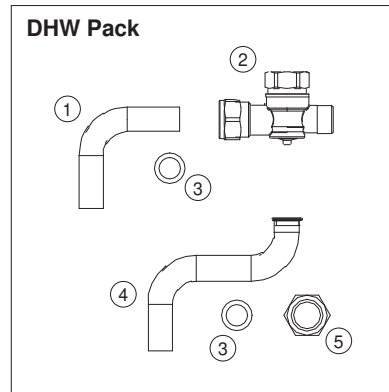

Accessory Pack

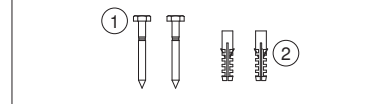

Flow Valve Pack

1. Pipe CH Flow
2. Washer CH
3. Valve Flow (with gauge)

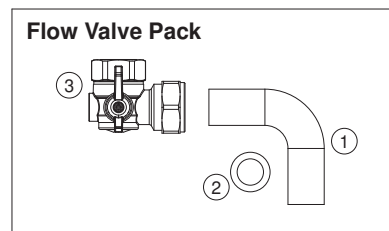

continued

8 UNPACKING CONT'D

Pack B Contents Telescopic

- A Telescopic Flue Terminal
- B Flue Turret
- C Rubber Terminal Wall Seal
- D Screw
- E Sealing Tape
- F Wall Seal (White)

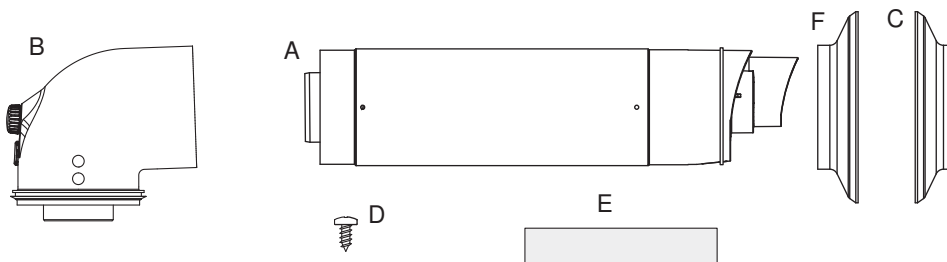

Pack B Contents Non-Telescopic

- A Flue Terminal
- B Flue Turret
- C Rubber Terminal Wall Seal
- D Cutting Aid
- E Wall Seal (White)

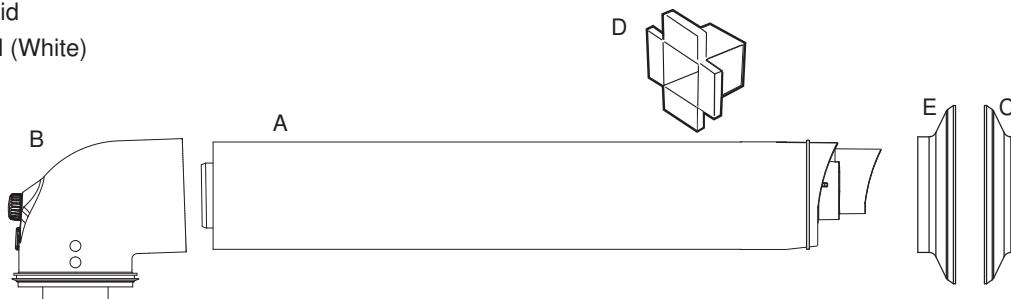

9 FRONT PANEL REMOVAL

1. Loosen the 2 screws retaining the front panel at the bottom.
2. Release catches at rear of door by pulling downwards.
3. Pull the underside front panel forward then lift upwards to remove.

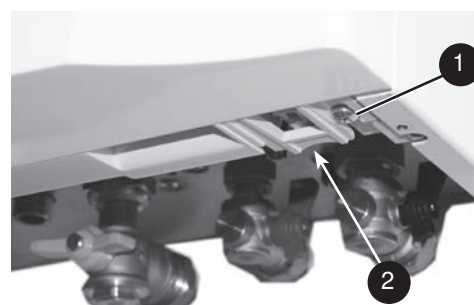

INSTALLATION

10 WALL MOUNTING TEMPLATE

The wall mounting template is located on the internal protective packaging. The template shows the position of the fixing and rear flue centre holes for a standard installation

Care MUST be taken to ensure the correct holes are drilled.

1. Tape template into the required position, ensuring its squareness by hanging a plumbline as shown.
2. If fitting a side flue, extend the flue centreline onto the side by **131mm** on a standard wall fix or **176mm** if using a stand-off bracket.
3. Mark the following on to the wall:
 - a. The selected group of wall mounting screw holes.
 - b. The centre position of the flue duct. Marking both the centre and the circumference of the flue duct.
4. Remove the template plate from the wall.

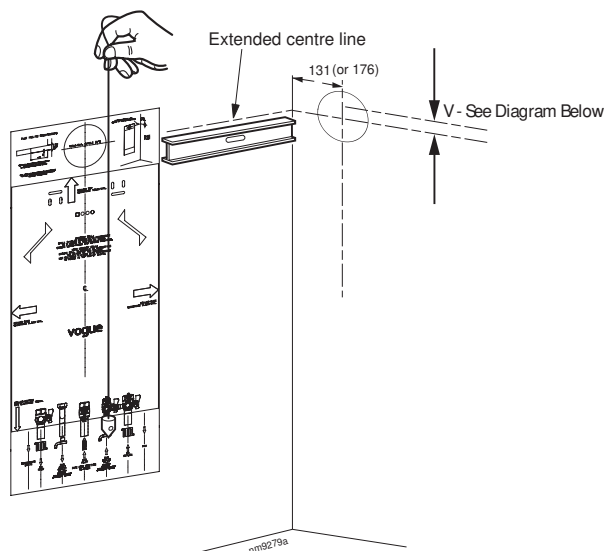

11 PREPARING THE WALL

IMPORTANT.

Ensure that, during the cutting operation, masonry falling outside of the building does not cause damage or personal injury.

1. Cut the flue hole (preferably with a 5" core boring tool), ensuring that the hole is square to the wall. Both wall faces immediately around the cut hole should be flat.
2. Drill 2 mounting holes (marked from template) with a 7.5mm / 8mm masonry drill and insert the plastic plugs, provided, for the wall mounting plate.
3. Locate 2 No.14 x 50mm screws in the wall mounting plate (one at each side, in any of the 3 holes provided at each side) and screw home. Ensure mounting bracket is level.

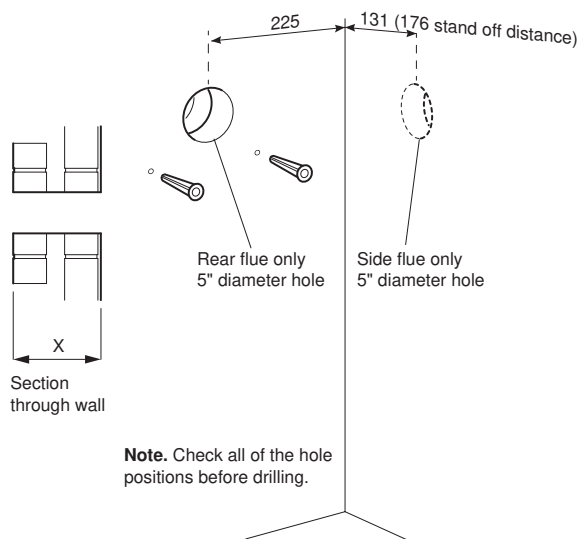

12 FITTING THE WALL MOUNTING PLATE

Screw the wall mounting plate to the wall using 2 wall plugs (previously fitted) with the 2 screws provided.

Choose one of the 2 sets of slots in left and right bank. Ensuring that at least one of the screws is fitted into a top slot and the mounting bracket is level.

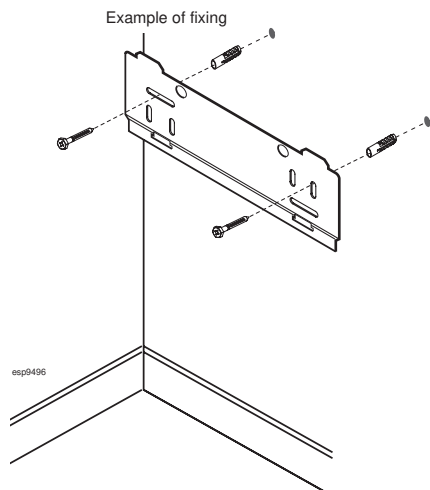

13 MOUNTING THE BOILER

1. Ensure the plastic plugs are removed from both the CH and DHW connections before mounting the boiler.

Note. boiler may contain residual water.

2. Lift the boiler onto the wall mounting plate (refer to the Introduction section for safe handling advice), locating it over the two tabs.

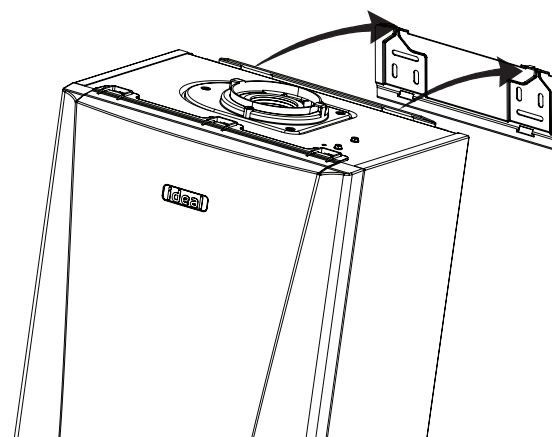

INSTALLATION

14 DETERMINING THE FLUE LENGTH AND FLUE PACKS REQUIRED

IMPORTANT. The boiler must be installed in a vertical position in accordance to the installation instructions.

FLUE KITS

Telescopic Flue 'B' Pack - contains: Flue turret, telescopic flue incorporating a terminal, rubber wall seal and instructions

Horizontal Flue Terminal (600mm long) 'B' Pack - contains: Flue turret, non telescopic single piece flue incorporating a terminal, rubber wall seal and instructions.

Horizontal Flue Terminal (1000mm long) 'B' Pack - Flue turret, telescopic flue incorporating a terminal, rubber wall seal and instructions.

Note. If 'B' packs are used on their own (either 1 piece or telescopic), then they can be fitted horizontally as the flue inside is designed to slope 1.5 degrees.

'D' Pack - contains: 1 metre length of flue pipe (Functional length 950mm), 1 support bracket and instructions.

When extension 'D' Packs are used the flue duct must incline 1.5 degrees away from the appliance, to allow the condensate to drain back to the boiler and out of the condensate drain. It is recommended that a support bracket is fitted on every 1 metre of pipe work used and the bracket is located as close to the collar as possible. The bracketing must ensure a 1.5 degree fall back to the appliance.

Optional Flue Finishing Kit - UIN 155988 & Concentric Flue Screw Retaining Kit (Optional Kit of mechanical fixing of flue joints)

Only use water as a lubricant during assembly.

The 'B' pack terminal is classed as part of the maximum flue length.

This flue system incorporates a removable flue outlet nose that utilises a push fit location system. This enables the installation of deflector, high level or balcony flue kits without the removal of the whole 'B' pack terminal. The appliance must not be operated without the desired outlet nose correctly fitted in place, ensuring the side location dimples are in line with the mounting face allowing the correct sealing of the components.

It is IMPORTANT that all attachments are fitted in accordance to the installation instructions provided with them.

The TURRET supplied in the 'B' Pack has an upper combustion sample point with a screw cap seal and a lower air sample point with an air stopper seal. Ensure all caps & seals are in place.

Additional Termination Kits available for use with these 'B' packs.

Flue Deflector Kit	The resistance is the equivalent of 1 metre of flue pipe and therefore must be deducted from any maximum flue length
High Level Flue Outlet Kit	The maximum permissible concentric flue length when using a standard (500mm) kit is 4.5 metres
Balcony Flue Outlet Kit	The maximum permissible concentric flue length when using this kit is dependant on the length of the balcony flue outlet run which combined with the concentric run must not exceed the maximum flue length requirement of the appliance it is to be fitted to

Total Maximum Permissible Horizontal Concentric Flue Length combining both 'B' Packs and 'D' Packs
(Measured from centreline of the turret to the outside of the wall terminal)

26 kW appliances	Total Maximum: 10 metres - minus any flue kit options or bends
32 & 40kW Appliances	Total Maximum: 8 metres - minus any flue kit options or bends

Total Maximum permissible Vertical Flue Length combining both Roof Terminal and 'D' Packs

26, 32 & 40kW Appliances	Total Maximum: 10 Metres - minus any bends
--------------------------	--

90° Elbow Kit 60/100 - (Equivalent flue length resistance = **1M**)

45° Elbow Kit 60/100 - (Equivalent flue length resistance = **0.6M**)

Minimum Horizontal Flue Lengths (Centre line of turret to outside of wall terminal)

Telescopic terminal = 350mm

One piece terminal = 285mm

Wall Thickness

Std Metric Brick 102.5mm wide

'B' Pack Flue Type	Minimum permissible Wall Thickness			Maximum permissible Wall Thickness		
	Rear Flue	Rear Flue + Std-Off	Side Flue	Rear Flue	Rear Flue + Std-Off	Side Flue
Horizontal Flue Terminal (600mm long) B Pack	154	102.5	102.5	513	482	433
Telescopic Flue B Pack	265	220	171	464	433	384
Horizontal Flue Terminal (1000mm long) B Pack	577	532	483	780	749	700
Horizontal Flue Terminal (1000mm long) B Pack cut 75mm	522	457	498	705	674	625

For Flue lengths between 658 & 708 use a Horizontal Flue Terminal (1000mm long) B Pack, cut 75mm off the end of the terminal section of the telescopic flue only.

INSTALLATION

15 DETERMINING THE FLUE LENGTH AND FLUE PACKS REQUIRED, CONT'D

FIGURE 1

Note. Maximum permissible flue length is measured from centre line of appliance flue outlet to outside wall face.

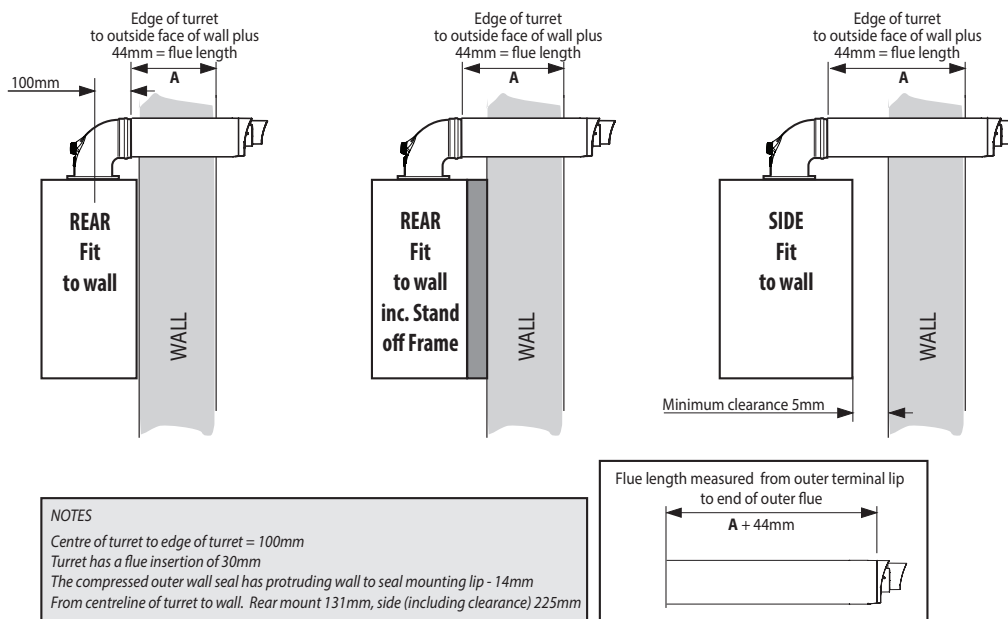

FIGURE 2

Actual maximum flue length requirements (outside edge of turret to outside face of wall plus 44mm (Cut Length))

	Minimum & Maximum finished flue lengths obtainable (dimension 'A' +44mm)								
	Horizontal Flue Terminal (600mm long) B Pack		Telescopic Flue B Pack		Horizontal Flue Terminal (1000mm long) B Pack (Telescopic)		Horizontal Flue Terminal (1000mm long) B Pack (Telescopic) Cut 75mm		
	Minimum	Maximum	Minimum	Maximum	Minimum	Maximum	Minimum	Maximum	
B Pack (Standard)	233	602	340	553	652	869	577	794	Max output 32 & 40 kW Max output 26 kW
Plus 1 (1m D pack)	1183	1552	1290	1503	1602	1819	1527	1744	
Plus 2 (1m D pack)	2133	2502	2240	2453	2552	2769	2477	2694	
Plus 3 (1m D pack)	3083	3452	3190	3403	3502	3719	3427	3644	
Plus 4 (1m D pack)	4033	4402	4140	4353	4452	4669	4377	4594	
Plus 5 (1m D pack)	4983	5352	5090	5303	5402	5619	5327	5544	
Plus 6 (1m D pack)	5933	6302	6040	6253	6352	6569	6277	6494	
Plus 7 (1m D pack)	6883	7252	6990	7203	7302	7519	7227	7444	
Plus 8 (1m D pack)	7833	8202	7940	8153	8252	8469	8177	8394	
Plus 9 (1m D pack)	8783	9152	8890	9103	9202	9419	9127	9344	
Plus 10 (1m D pack)	9733	N/A	9840	10000	N/A	N/A	N/A	N/A	

Note; Telescopic flue B Pack or attached "D" pack extensions do not need to be cut between minimum and maximum values shown above (except where specified). Horizontal Flue Terminal (600mm long) B Pack flue will require cutting on values below maximum values shown above.

INSTALLATION

16 CUTTING & SETTING THE FLUE LENGTH

TELESCOPIC FLUES

TELESCOPIC FLUE B PACK SHOULD ONLY BE ADJUSTED FOR USE WITHIN ITS SPECIFIED RANGE AND MUST NOT BE CUT

HORIZONTAL FLUE TERMINAL (1000MM LONG) B PACK (TELESCOPIC) MUST ONLY BE CUT IF REQUIRED FLUE LENGTHS ARE BETWEEN 602 & 652MM. THIS WILL REQUIRE 75MM TO BE CUT OFF THE TERMINAL END OF THE 1000MM TELESCOPIC FLUE.

ALL OTHER LENGTHS OBTAINED USING "D" PACK EXTENSIONS IN FLUE LENGTH TABLE 1, COLUMN "HORIZONTAL FLUE TERMINAL (1000MM LONG) B PACK CUT 75MM" (TELESCOPIC) SHOULD HAVE THE 75MM CUT OFF THE "D" PACK EXTENSION AND NOT TELESCOPIC FLUE

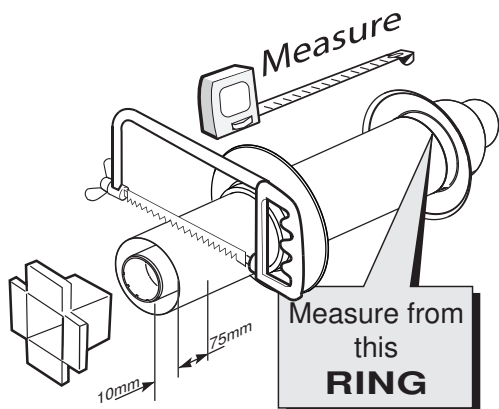

CUT 75MM OFF HORIZONTAL FLUE TERMINAL 1000MM LONG B PACK (TELESCOPIC)

1. Measure cut flue length ($A+44\text{mm}$). (If required telescopic length is not between 658 and 708 then proceed to set flue 7b).
2. Remove telescopic end piece from the flue body and set aside.
3. Mark the circumference 75mm from the open end of the outer flue.
4. Cut along the 75mm mark cutting **only the outer flue** ensuring the cut is square.
5. Dress the cut end to make sure all burr is removed and the cut edge is in its original shape.
6. Measure 20mm from the newly cut edge of the outer flue, place a mark at the top of the flue approximately 20mm wide & write stop the terminal side of the line.
7. Mark the inner tube 10mm longer than the outer tube around its circumference and cut following the mark to ensure its cut square
8. Remove all burrs and place a chamfer on the outer edge to aid assembly.
9. Re-assemble telescopic section.

SETTING TELESCOPIC FLUE B PACK

1. Measure the required flue length ($A+44\text{mm}$).
2. Measure from the outer terminal lip to end of outer flue. Pull apart flue until desired length is achieved. **ENSURE THE STOP MARK IS NOT VISIBLE, IF IT IS, THE FLUE IS TOO SHORT AND SHOULD NOT BE USED.**
3. Check that both flue seams are at the top and the outlet terminal is upper most.
4. Drill a 3.5mm hole through one of the 2 outer side holes into the inserted outer flue. Take care not to pierce the inner plastic flue.
5. Seal the joint on the outer air duct with the tape provided.
6. Fit internal and external wall seals (see installing flue)

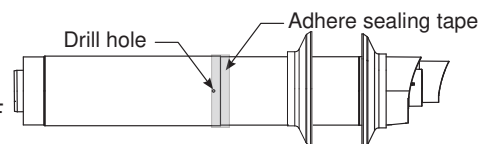

CUTTING HORIZONTAL FLUE TERMINAL (600MM LONG) B PACK

1. Measure the required cut flue length ($A+44\text{mm}$). If inside the dimensions shown in Figure 2 "1 Piece 600mm" proceed.
2. Measure from the outer terminal lip to end of outer flue. Mark the required cut length ($A+44$) around the circumference of the outer flue and cut following the mark to ensure its cut square.
3. Dress the cut end to make sure all burr are removed and the cut edge is in its original shape.
4. Mark the inner tube 10mm longer than the outer tube around its circumference and cut following the mark to ensure its cut square.
5. Remove all burrs and place a light chamfer on the outer edge to aid assembly.

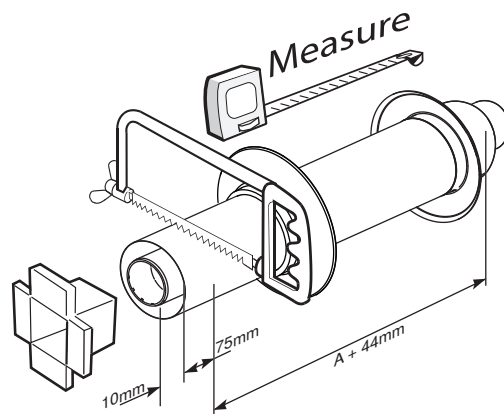

INSTALLATION

17 INSTALLING THE FLUE

FITTING FLUE THROUGH THE WALL

1. Measure wall thickness and add 14mm.
2. Measure from the outer terminal lip towards outer flue, place a small location mark at the dimension acquired at point 1.
3. Add a further 14mm to the dimension, obtain at item 1 and place an additional small location mark.
4. Fit external black wall seal ensuring the outer lip is in contact with the lip you have been measuring from (see fig 1)
5. Fit the internal wall seal approximately 65mm before the outer of the 2 location marks.
6. For an internal fit place flue terminal in the centre of the 5" drilled hole in the wall. Apply pressure and lightly move the flue left to right or up and down. This will cause the outer flange to fold in and allow the flue to pass through the wall.
7. Push through a further 65mm or until the inner flange is press against the inner wall. This will allow the outer flange to return to its original shape.
8. Pull back the flue until the first of the 2 location marks re level with the internal face of the wall.

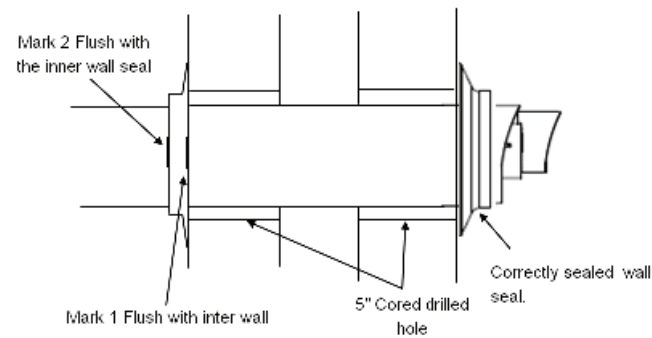
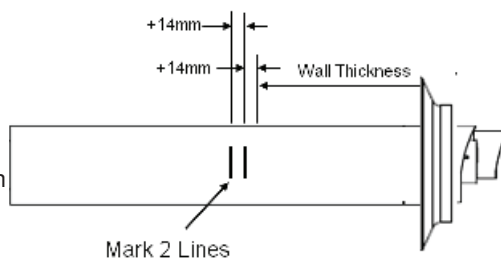

Note. If the 2 location marks are not visible then the flue is not pulled back far enough to obtain the correct seal. If the 1st location mark has passed the face of the wall the flue has been pulled to far back and the outer wall seal will have been dislodged from its mounting and will need to be refitted.

9. When 1st mark is in line with the wall, whilst holding the flue firmly, push the white wall sealing flange to the wall until the 2nd of the two marks is just visible. If the last location mark is clearly passed the white inner wall seal then the outer wall seal will have been dislodged from its mounting and will need to be re-fitted.
10. Ensure the seam and the outlet terminal are at the top and fitted as shown.

Note. If less than 50% of the length of the flue is internal the flue should be fitted from outside.

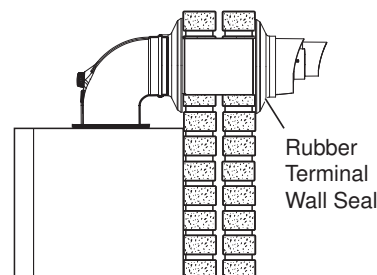
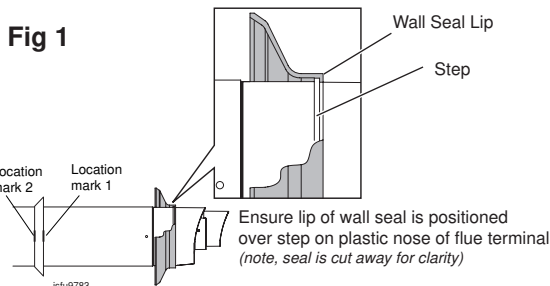

FITTING THE TURRET

1. Ensure the rubber seal is fitted correctly on the appliance manifold and that all flue seals are undamaged.
2. Hold the flue firmly and push the turret on until it has travelled 30mm on to the flue pipe and is fully engaged. Make sure the flue has not rotated or moved forward during fitting and the flue seam is upper most.
3. Push the turret into the manifold ensuring the upper plastic lip is flush with the top of the manifold.
4. Fully engage the clamp location section into the manifold location holes. Rotate down on to turret flange.
5. Secure clamp to appliance using securing screw.
6. Ensure all sample points are accessible and all sample plugs and caps are fitted.

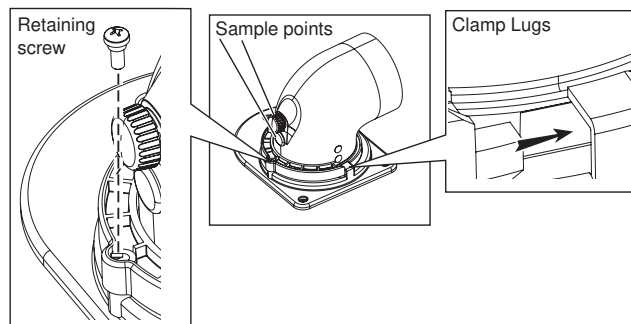
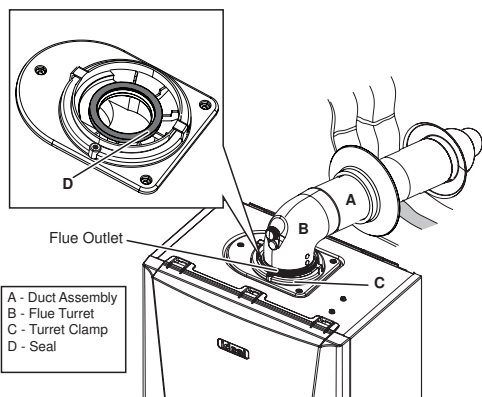

18 CONDENSATE DRAIN

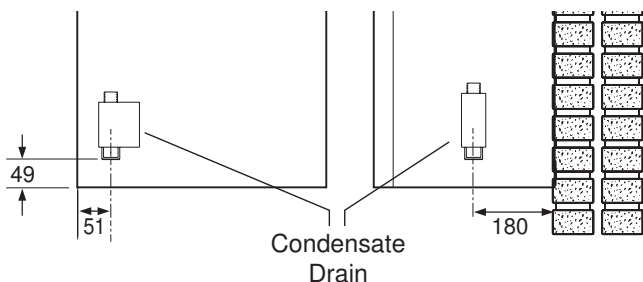

This appliance is fitted with a siphonic 75mm condensate trap system that requires filling before operating the appliance for the 1st time or after maintenance.

All condensate pipework should conform to the following:

- a. Where a new or replacement boiler is being installed, access to an internal 'gravity discharge' termination should be one of the main factors considered in determining boiler location.
- b. Plastic with push fit or solvent connections.
- c. Internal plastic pipe work a minimum of 19mm ID (typically 22mm OD)
- d. External plastic pipe must be a minimum of 30mm ID (typically 32 OD) before it passes through the sleeved wall.
- e. All horizontal pipe runs, must fall a minimum of 45mm per metre away from the Boiler.
- f. External & unheated pipe work should be kept to a minimum and insulated with Class "O" waterproof pipe insulation.
- g. All installations must be carried out in accordance to the relevant connection methods as shown in the "Condensate installation diagrams" & BS6798:2009
- h. Pipe work must be installed so that it does not allow spillage into the dwelling in the event of a blockage (through freezing)
- i. All internal burrs should be removed from the pipe work and any fittings.

In order to minimise the risk of freezing during prolonged very cold spells, one of the following methods of terminating condensate drainage pipe should be adopted.

Internal Drain Connections

Wherever possible, the condensate drainage pipe should be routed to drain by gravity to a suitable internal foul water discharge point such as an internal soil and vent stack or kitchen or bathroom waste pipe etc. See Figs 1 and 2.

Condensate Pump

Where gravity discharge to an internal termination is not physically possible or where very long internal pipe runs would be required to reach a suitable discharge point, a condensate pump of a specification recommended by the boiler or pump manufacturer should be used terminating into a suitable internal foul water discharge point such as an internal soil and vent stack or internal kitchen or bathroom waste pipe etc. (fig 3).

External Drain Connections

The use of an externally run condensate drainage pipe should only be considered after exhausting all internal termination options as described previously. An external system must terminate at a suitable foul water discharge point or purpose designed soak away. If an external system is chosen then the following measures must be adopted:

The external pipe run should be kept to a minimum using the most direct and "most vertical" route possible to the discharge point, with no horizontal sections in which condensate might collect.

- For connections to an external soil/vent stack see Fig 4. Insulation measures as described should be used.
- When a rainwater downpipe is used, an air break must be installed between the condensate drainage pipe and the downpipe to avoid reverse flow of rainwater into the boiler should the downpipe become flooded or frozen, see Fig 5.
- Where the condensate drain pipe terminates over an open foul drain or gully, the pipe should terminate below the grating level, but above water level, to minimise "wind chill" at the open end. The use of a drain cover (as used to prevent blockage by leaves) may offer further prevention from wind chill. See Fig 6.
- Where the condensate drain pipe terminates in a purpose designed soak away (see BS 6798) any above ground condensate drain pipe sections should be run and insulated as described above. See Fig 7

Unheated Internal Areas

Internal condensate drain pipes run in unheated areas, e.g. lofts basements and garages, should be treated as external pipe.

Ensure the customer is aware of the effects created by a frozen condensate and is shown where this information can be found in the user manual.

Figure 1 - Connection of Condensate Drainage Pipe to Internal Soil & Vent Stack

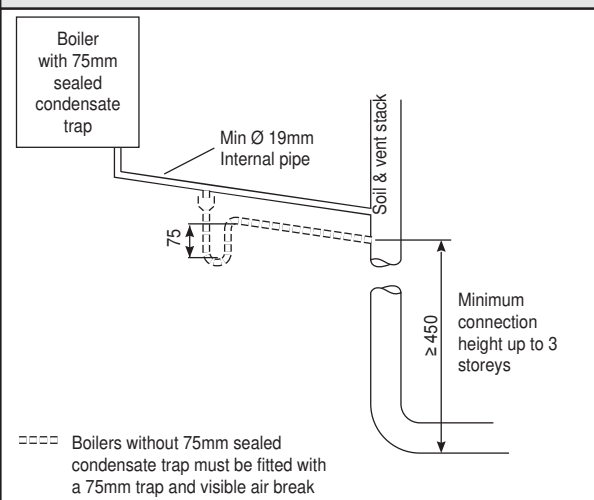
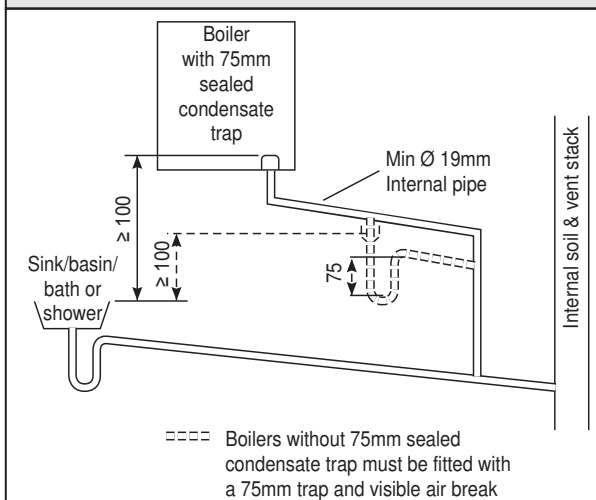

Figure 2 - Connection of a Condensate Drainage Pipe Downstream of a Sink, Basin, Bath or Shower Water Trap to Internal Soil Vent Stack



continued

19 CONDENSATE DRAIN - CONT'D.....

Figure 3 - Connection of a Condensate Pump Typical Method (see manufacturers detailed instructions)

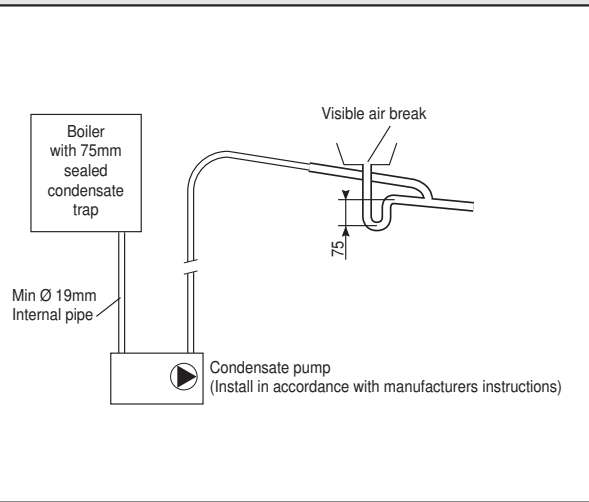

Figure 4 - Connection of condensate Drainage Pipe to External Soil & Vent Stack

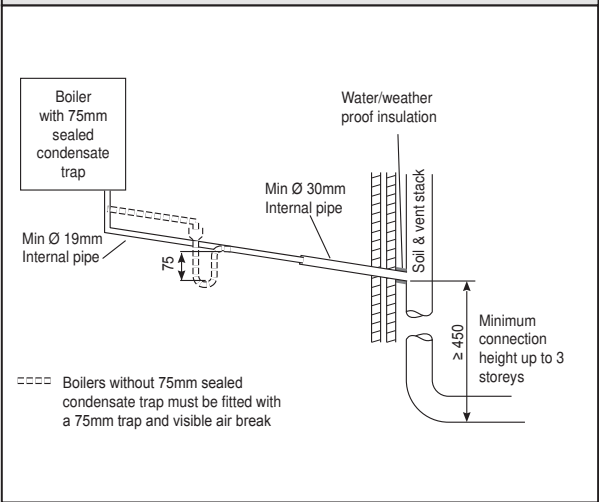

Figure 5 - Connection of a Condensate Drainage Pipe to an External Rainwater Downpipe (only combined foul/rainwater drain)

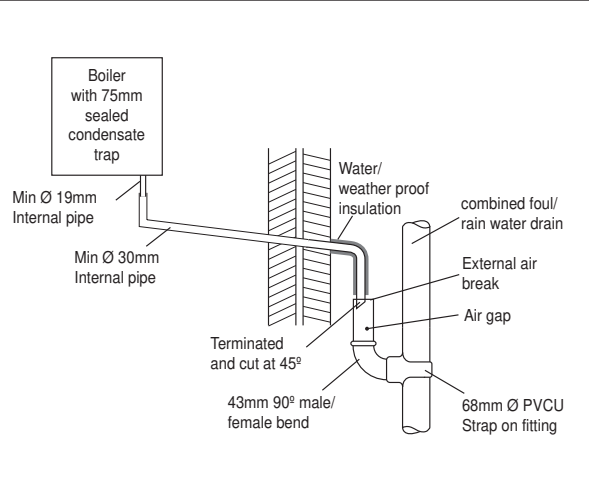

Figure 6 - Connection of Condensate Drainage Pipe Upstream of a Sink, Basin, Bath or Shower Waste Trap to External Drain, Gully or Rainwater Hopper

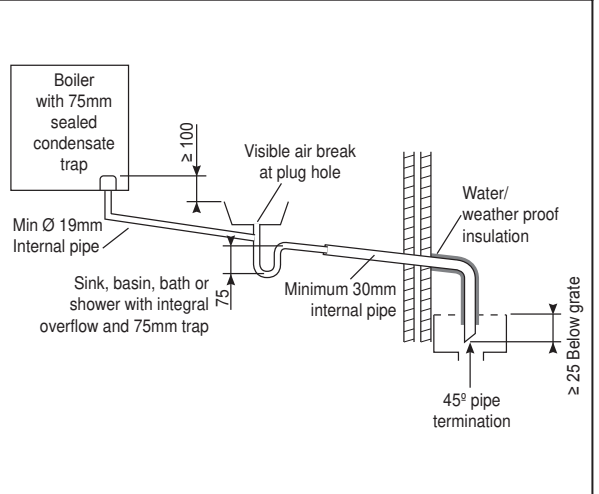
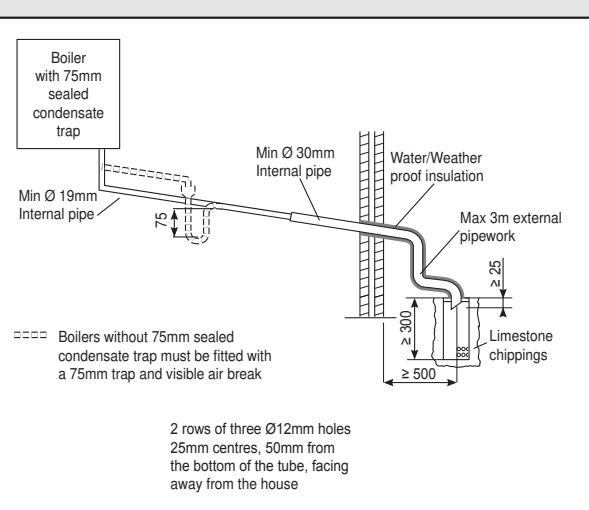

Figure 7 - Connection of a Condensate Drainage Pipe to an External Purpose Made Soak Away.



INSTALLATION

20 FITTING THE OPTIONAL ROOF FLUE KIT (Flat or Pitched)

Note.

A flat or pitched roof flashing plate (not supplied) is required before proceeding with the installation of this kit.

This kit is suitable for both flat and pitched roof terminations, using a concentric flue to run vertically from the top of the boiler and terminating above roof level.

Connection to the top of the boiler is made using a separately supplied vertical connector.

WEATHER PROOFING

Where the flue passes through the roof line an adequate seal must be made. This is achieved by using either:

- Flat roof weather collar
- or
- Universal weather collar.

ACCESSORIES

Flue Duct Extension Kits are available for flue lengths extending beyond 1m. These packs contain 1m extension ducts and may be cut to the desired length.

If the offset vertical option is used an elbow Kit is required. For a full accessories list refer to page 7 , Optional Extras and Frame 21, Flue Arrangement.

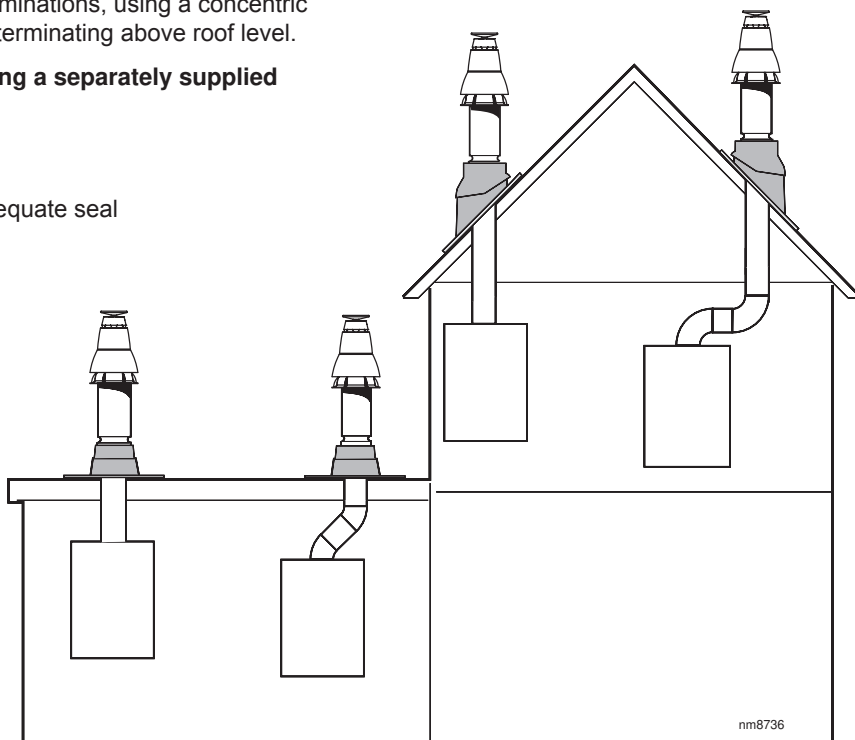

nm8736

21 ROOF FLUE KIT CONTENTS / OPTIONS

Flue Terminal
UIN 203132

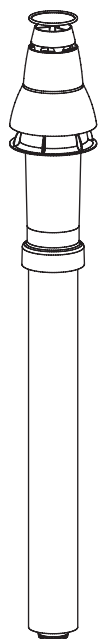

Flue Seal Collar - Flat Roof
UIN 152259

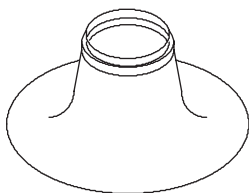

Vertical connector
UIN 208175



90° elbow
UIN 203130



45° elbow
UIN 203131

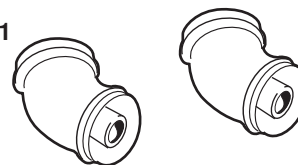

Flue Seal Collar - Universal
UIN 152258

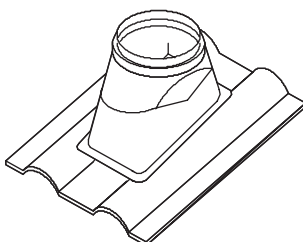

Roof Flue Extension Duct
UIN 203129

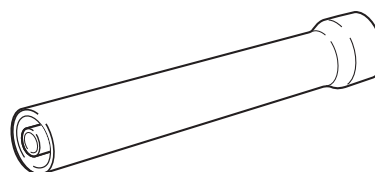

Flue duct support



Flue duct support



3G9626a

INSTALLATION

22 FLUE TERMINAL POSITION

The terminal should be positioned so that products of combustion can safely disperse at all times.

Plumbing may occur at the termination so, where possible, terminal positions where this could cause a nuisance should be avoided.

Minimum dimensions are shown below

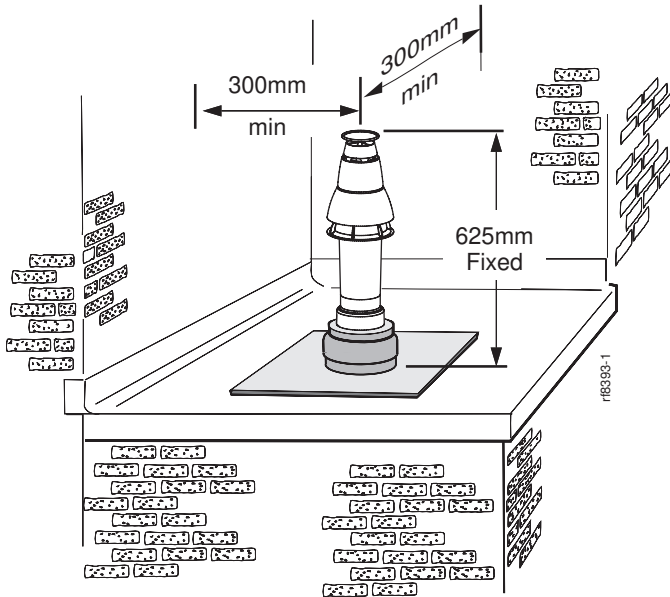

Flat roof - with structure

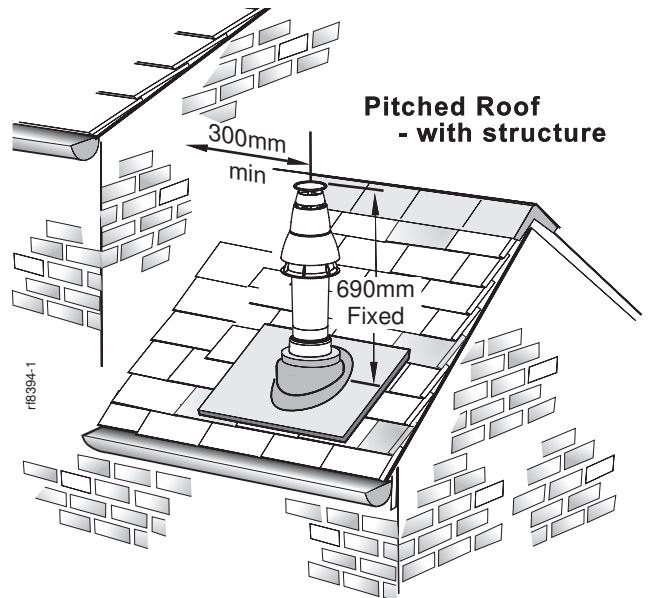
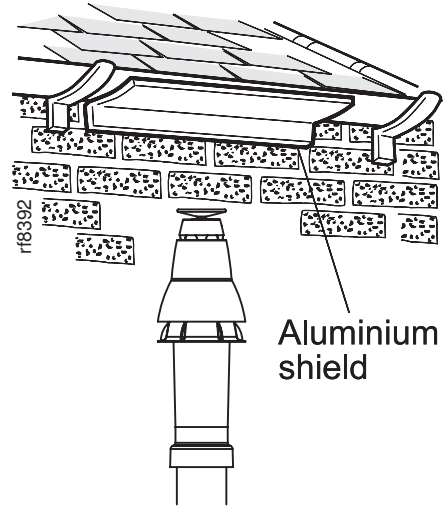

Pitched Roof - with structure

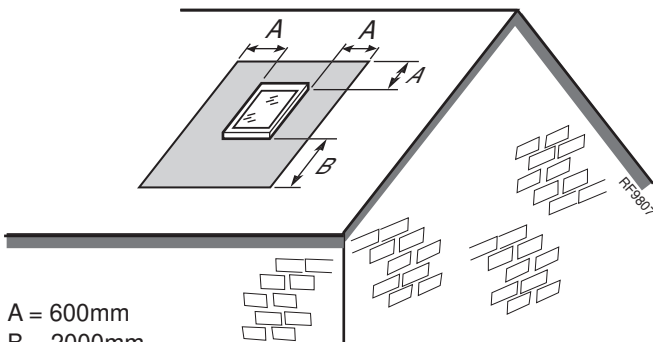

A = 600mm
B = 2000mm

The flue terminal shall not penetrate the shaded area of the roof

Terminal Position	Minimum Dimension
Directly below an opening, air brick, windows, etc.	300 mm
Below plastic / painted gutters	300 mm
Painted surface	300 mm
Below eaves or balcony	500 mm
Below velux windows	2000mm
Above or side of velux windows	600mm

Note.

The equivalent flue length resistance of the elbow kits are:

90° elbow kit = 1m

45° elbow kit = 0.6m

INSTALLATION

23 ASSEMBLING THE ROOF FLUE KIT

Determine the correct height that the flue should terminate above the roof. If after calculating or measuring the overall flue height from the top of the boiler, it is necessary to cut both pipes of assembly A, then ensure they are cut equally leaving the inner flue tube longer than the outer air tube as supplied.

Ensure the cut pipe ends are free from any burrs.

1. Position the roof flashing plate (supplied separately) over the hole cut in the roof and insert flue terminal from the roof end.

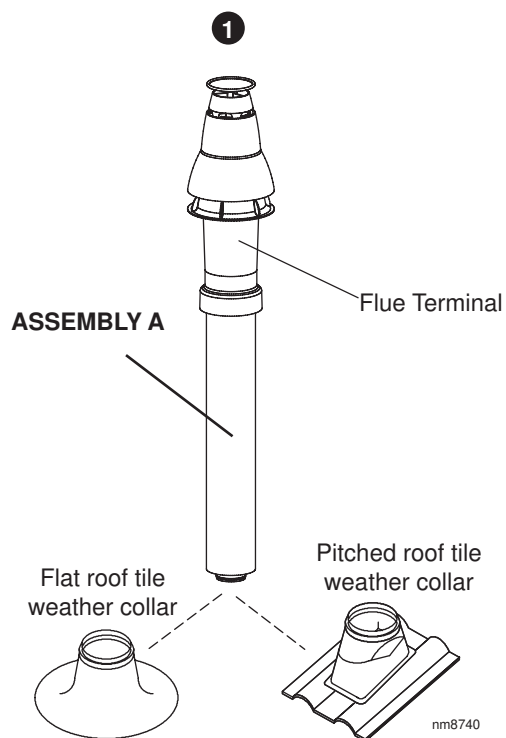
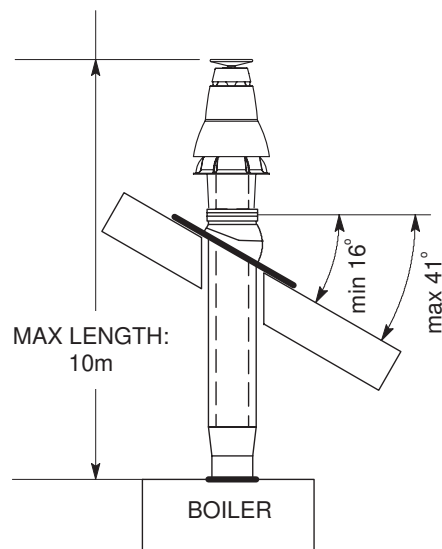

2. Fit the vertical connector (supplied separately) in accordance with the instructions provided with the vertical connector kit.
3. Secure the vertical connector by applying downward pressure on the connector.
4. Position the clamp on the top face of the flue manifold and push it horizontally backwards. Locate both clamp lugs into the flue manifold and secure to the flue manifold with the M5 retaining screw (as shown in Frame 17).
5. "Push" fit extension duct (if required (supplied separately)) into vertical connector.

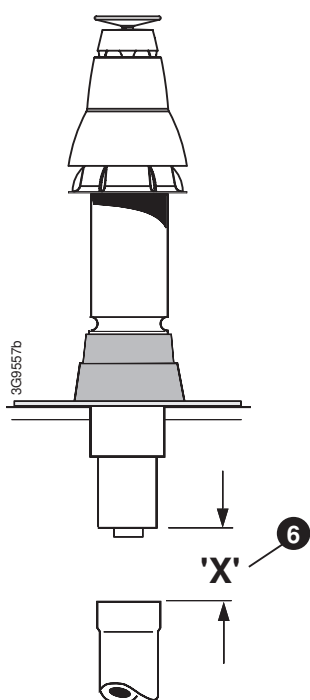
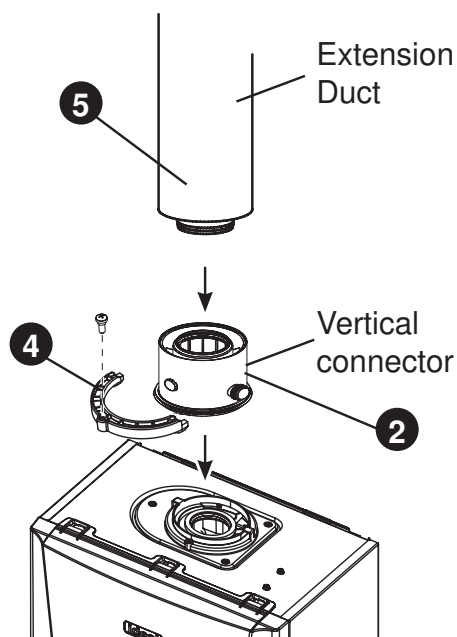

6. If the last extension duct requires cutting, measure 'X', the distance (outer ducts), between the duct and the terminal and add 100 mm to this dimension. This gives the length of the last extension duct.

Note. Check the position of the inner flue duct relative to the outer duct on the assembled extension duct(s) and ensure the terminal flue duct is cut longer than the air duct to ensure engagement in the final flue duct seal.

7. Finally ensure the roof flashing plate is correctly sealed to the roof.

INSTALLATION

24 CONNECTIONS & FILLING

NOTES.

Ensure all boss blanking plugs are removed before connecting hardware. Each valve must be fitted to the correct boss as shown in the picture.

Ensure each union is fitted with fibre seals provided.

Do not subject any of the isolating valves to heat as the seals may be damaged.

Note. The domestic hot water flow rate is automatically regulated to a maximum:		
26 = 10.7	l/m	(2.2 gpm)
32 = 13.1	l/m	(2.8 gpm)
40 = 16.4	l/m	(3.2 gpm)

WATER CONNECTIONS CH

1. Connect the CH flow service valve and copper tail provided in the hardware pack to the threaded boss connection provided at the lower rear of the boiler.
2. Connect the CH rtn. valve (black handle) and copper tail.
3. If connecting the boiler to heating loads in excess of 17.6kW (60,000 Btu/h), connecting flow and return heating systems pipework must be sized in 28mm diameter at the point of pipe connection to the boiler tails. use 22mm x 28mm pipe adaptors as appropriate.

WATER CONNECTIONS DHW

1. Fit the DHW inlet service valve (blue handle) and copper tail to the threaded boss connection ensuring the seal provided is correctly located.
2. Fit the DHW outlet pipe tail to DHW outlet connection, ensuring the seal provided is correctly located.
3. Fit the filling loop provided between the DHW inlet valve and the CH return valve

FILLING

IMPORTANT - when filling:

When filling, there may be a slight water leak from the air vent therefore electrical connections should be protected.

1. Ensure Filling Loop is connected
2. Ensure dust cap on auto air vent is slackened off .
3. Check all isolation handles on all water connections are in the open position.
4. Open handle ❶ on the filling loop, then slowly open handle ❷ until pressure gauge reads between 1 to 1.5 bar.
5. Once pressure gauge dial reads between 1 - 1.5 bar turn the filling loop isolation valves back to the closed position.
6. Disconnect filling loop at the LH side, ensuring top hat washer is retained and screw on blanking cap.
7. Connect extended blanking cap and top hat washer to filling loop pipe.

Note. Fully open all DHW taps and ensure water is flowing freely. Once satisfied close all taps.

GAS CONNECTION

IMPORTANT. The gas service cock is sealed with a non-metallic blue fibre washer, which must not be overheated when making capillary connections. Refer to Frame 1 for details of the position of the gas connection.

For additional gas supply info refer to "Gas Supply" on page 8.

PRESSURE RELIEF VALVE DRAIN

The pressure relief valve connection, located at the bottom right-hand side of the boiler, comprises a 15mm diameter stub pipe.

The Installer to provide a compression joint on the end of the stub pipe. This assists with pipe removal when servicing.

The discharge pipe should be positioned so that the discharge of water or steam cannot create a hazard to the occupants of the premises or damage the electrical components and wiring.

A purpose made pressure relief valve drain pipe is provided with the boiler to allow safe discharge through a wall to the outside of the building. This is particularly relevant to 'high rise' installations but can be used for all installations.

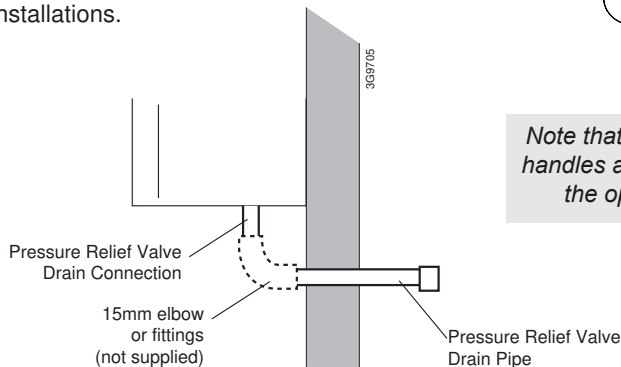

Note that all isolation handles are shown in the open position.

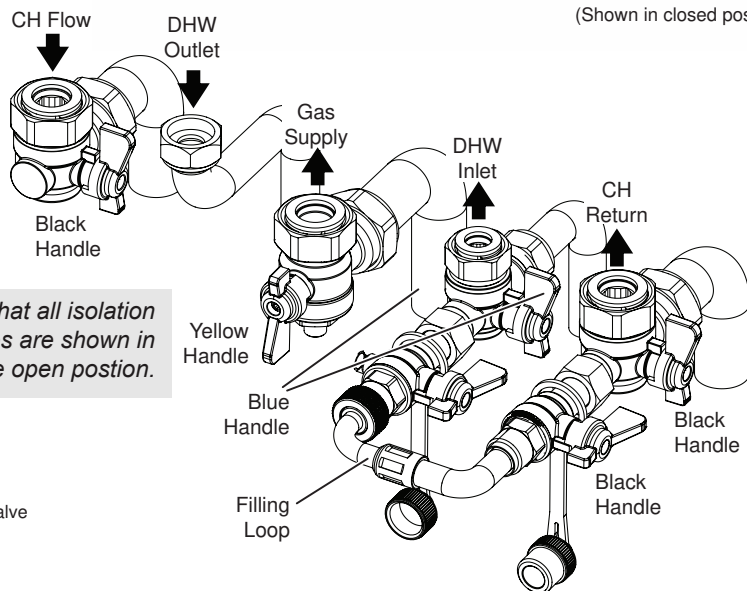

Handle ❶
(Shown in closed position)

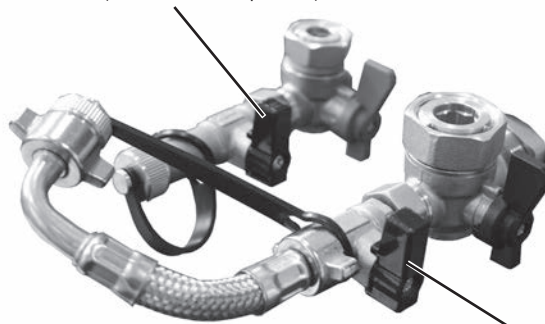

Handle ❷
(Shown in closed position)

25 ELECTRICAL CONNECTIONS

WARNING. This appliance **MUST** be earthed.

A mains supply of 230Vac ~ 50 Hz is required.

The fuse rating should be 3A. All external controls and wiring must be suitable for mains voltage.

Wiring external to the boiler **MUST** be in accordance with the current I.E.E. (BS.7671) Wiring Regulations and any local regulations.

Wiring should be 3 core PVC insulated cable, not less than 0.75mm² (24 x 0.2mm), and to BS 6500 Table 16. For IE reference should be made to the current ETCI rules for electrical installations.

Connection must be made in a way that allows complete isolation of the electrical supply such as a double pole switch having a 3mm (1/8") contact separation in both poles. The means of isolation must be accessible to the user after installation.

26 MAINS WIRING

The Vogue Combi boiler comes pre-fitted with 1.8m of mains cable. This must be connected to a permanent live supply and **NOT** switched by thermostats/programmers. For installers wishing to change this cable proceed as follows.

Replacement wiring should comply with the notes in Frame 28 & 29.

1. Isolate the mains supply to the boiler.
2. Remove the front panel (refer to Frame 9).
3. Swing the control box down into the service position (refer to Frame 46).

4. Remove the Live, Neutral and Earth wires from the terminal block.
5. Loosen the cable clamp and withdraw the mains cable.
6. Route the replacement cable back through the cable clamp and grommet and re-tighten to provide cord anchorage.
7. Connect the Live, Neutral and Earth wires to the terminal strip. When making the mains electrical connections to the boiler it is important that the wires are prepared in such a way that the earth conductor is longer than the current carrying conductors, such that if the cord anchorage should slip, the current carrying conductors become taut before the earthing

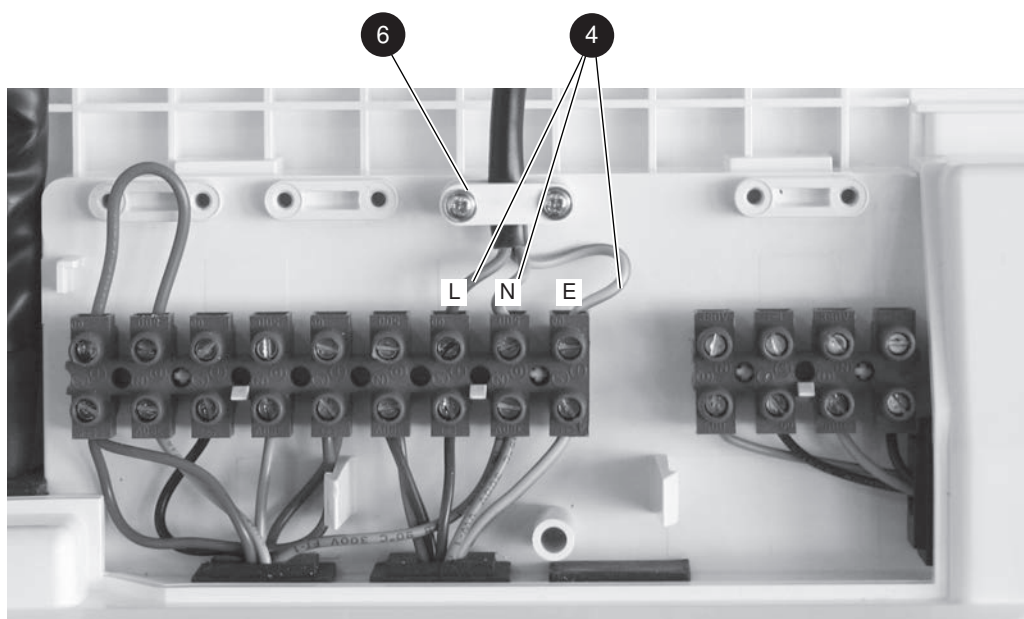

continued

INSTALLATION

27 OPTIONAL SYSTEM CONTROLS KITS

Ideal offer 5 kits as follows:-

(see individual kits for installation instructions)

Combi Mechanical Timer (24 hr): 24 hour mechanical CH timer fits into the control box of the boiler. This can be fitted in conjunction with a Room Thermostat.

Combi Electronic Timer (7 day): 7 day electronic CH timer fits into the control box of the boiler. This can be fitted in conjunction with a room thermostat. Features English language installation help messages.

Combi RF Electro-Mechanical Programmable Room Thermostat Kit (24 hr): combined 24 hour mechanical timer and room thermostat with wireless communication to the receiver unit, which fits into the control box of the boiler.

Combi RF Electro-Mechanical Timer and RF Room Thermostat Kit (24 hr): RF Room Thermostat with wireless communication to the RF 24 hour electro-mechanical CH timer, which fits into the control box of the boiler.

Weather Compensation Kit: allows outside temperature sensing.

28 INTERNAL WIRING

The Vogue Combi boiler comes pre-fitted with a link wire between the Room Thermostat/Timer connections on the terminal strip. This creates a permanent call for heat and must be removed when adding a Room Thermostat/Timer.

To add wired external Room Thermostats, Timers or Programmers proceed as follows:-

1. Isolate the mains supply to the boiler.
2. Remove the front panel (refer to Frame 9).
3. Swing the control box down into the servicing position (refer to Frame 46).
4. Route incoming cables through the grommets in the bottom panel (note: grommets are 'blind' and will require puncturing) and secure using clamps and screws provided in the hardware pack.
5. Remove terminal block cover.
6. Connect wires to terminal block.
7. Re-assemble in reverse order.

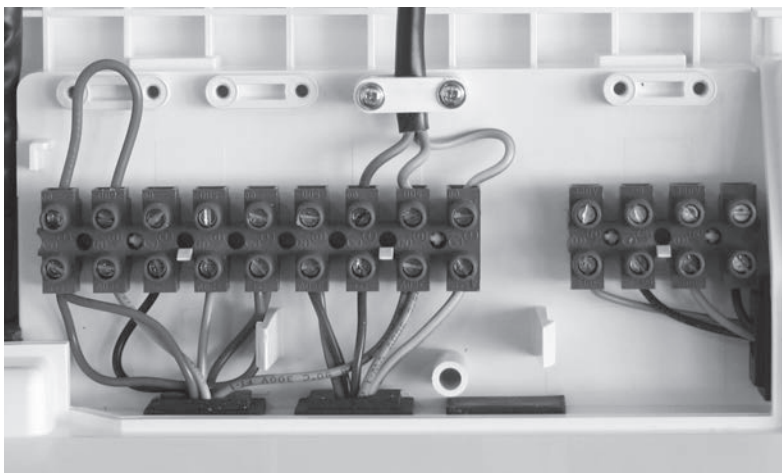

29 INTERNAL WIRING

(A) Internal Timer with Room Stat or Programmable Room Stat

1. Remove the link wire between the Room Stat/Timer terminals
2. Connect the Room Stat or Programmable Room Stat across the terminals as shown in the Diagram.
3. If the Room Stat has a neutral connection then connect this to the fused spur neutral.

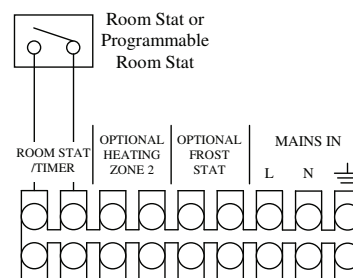

continued.

30 SYSTEM CONTROL WIRING - CONT'D

(B) External Timer and Room Stat

1. Remove the link wire between the Room Stat/Timer terminals
2. Connect the Room Stat and Timer across the terminals as shown in the Diagram.
3. If the Room Stat has a neutral connection then connect this to the fused spur neutral.

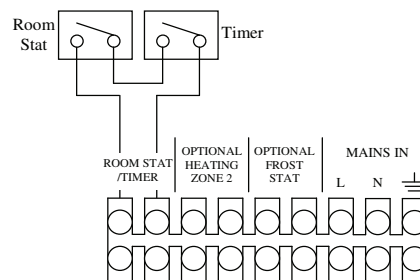

(C) Use of General Live for System Controls

1. Remove the link wire between the Room Stat/Timer terminals
2. The live feed to the Room Stat must be isolated by the same isolator that supplies the boiler.

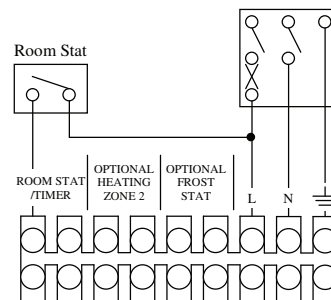

(D) Frost Thermostat

If parts of the system are vulnerable to freezing or the system controls are likely to be left off during cold weather then a frost stat should be fitted in conjunction with a pipe thermostat. Position the frost thermostat in the area that is vulnerable to freezing and then connect it as shown in the diagram. If the boiler is installed in a garage it may be necessary to fit a pipe thermostat, preferably on the return pipe work.

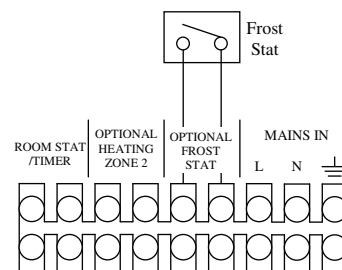

(E) Weather Compensation

1. Connect the Outside Sensor across the terminals as shown in the Diagram.

DO NOT CONNECT 230V TO THESE TERMINALS OR THE BOILER ELECTRONICS WILL BE DAMAGED

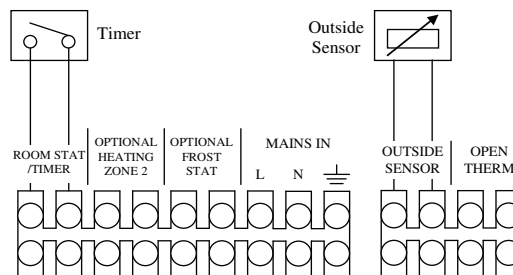

(F) OPENTHERM PROGRAMMABLE ROOM STAT

1. Remove the link wire between the Room Stat/Timer terminals
2. Connect the OpenTherm Programmable Room Stat across the terminals as shown in the Diagram.
3. Unclip the 3 way connector from the back of the internal timer plastics and connect to the 3 way connector adjacent to the plastics.

DO NOT CONNECT 230V TO THESE TERMINALS OR THE BOILER ELECTRONICS WILL BE DAMAGED

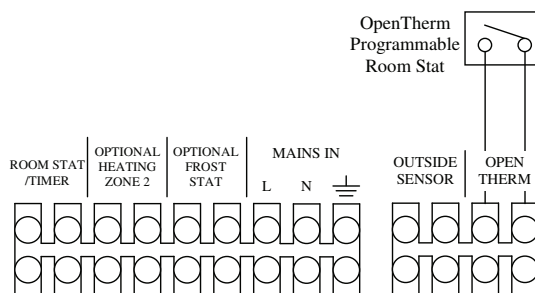

(G) Heating Zone 2

It is possible to set 2 different flow temperature targets for 2 different heating zones. To do this Programmable Room Thermostats should be connected as shown in the Diagram. The Flow Temperature target for zone 1 is set using the CH temperature Knob, while the Flow Temperature target for Zone 2 is set using the boiler menu (see Frame 41). Note that if there is a demand from both zones at the same time then the higher target temperature will be used.

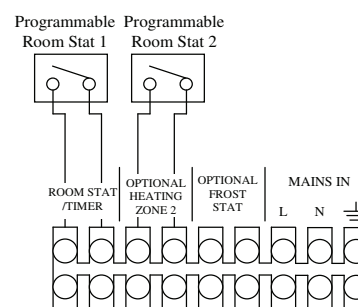

INSTALLATION

31 WIRING DIAGRAM

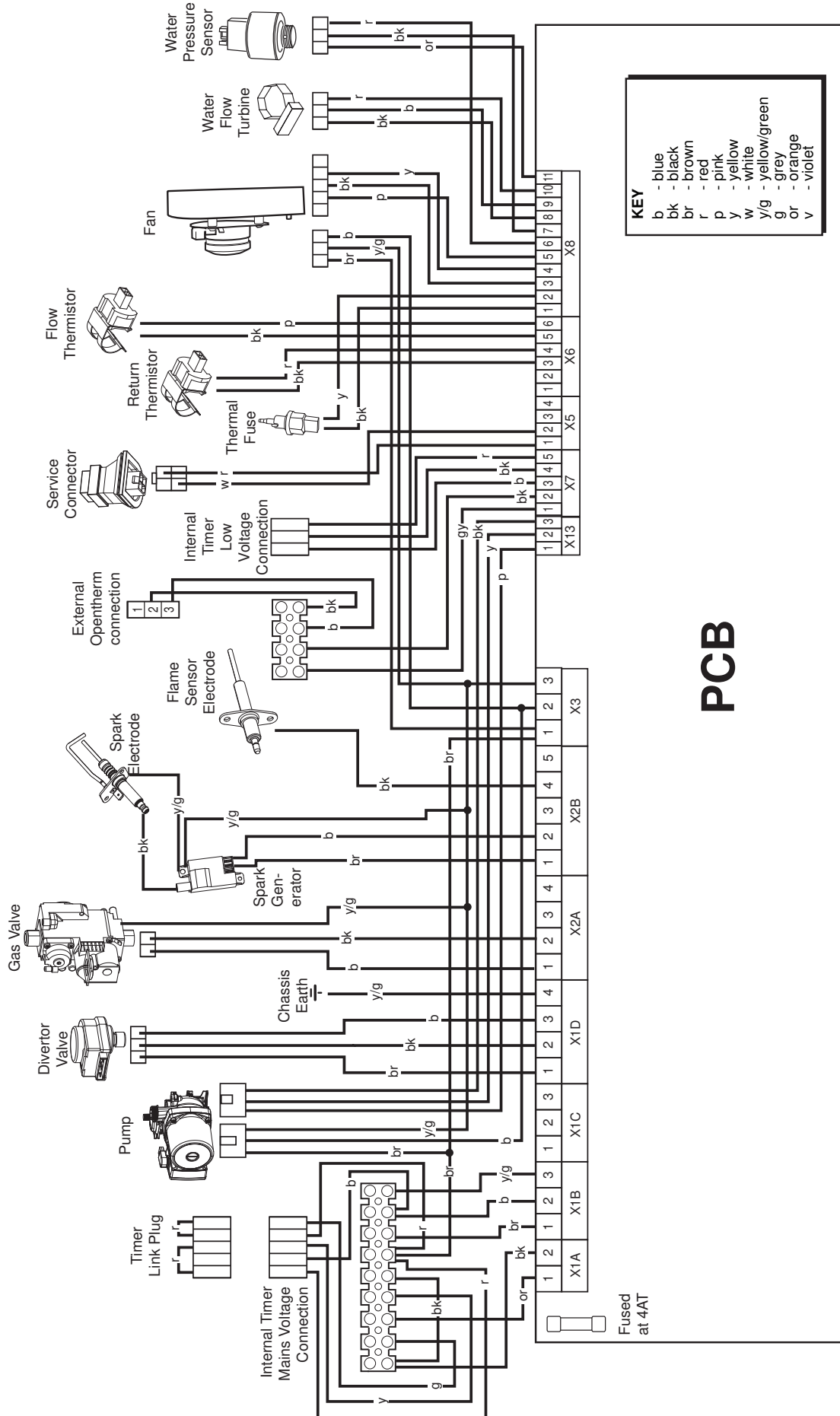

32 COMMISSIONING AND TESTING

A. Electrical Installation

1. Checks to ensure electrical safety should be carried out by a competent person.
2. ALWAYS carry out the preliminary electrical system checks, i.e. earth continuity, polarity, resistance to earth and short circuit, using a suitable test meter.
3. After wiring the boiler, all grommets in the bottom panel MUST be in place to ensure that boiler case sealing is maintained.

B. Gas Installation

1. The whole of the gas installation, including the meter, should be inspected and tested for tightness and purged in accordance with the recommendations of BS. 6891. In IE refer to IS.813:2002.
2. Purge air from the gas installation by the approved methods only.

WARNING. Whilst effecting the required gas tightness test and purging air from the gas installation, open all windows and doors, extinguish naked lights and **DO NOT SMOKE.**

GENERAL

Please Note: The combustion for this appliance has been checked, adjusted and preset at the factory for operation on the gas type defined on the appliance data plate. No measurement of the combustion is necessary. **DO NOT** adjust the air/gas ratio valve.

Having checked:

- That the boiler has been installed in accordance with these instructions.
- The integrity of the flue system and the flue seals, as described in the Flue Installation section.

Proceed to put the boiler into operation as follows:

CHECK THE OPERATIONAL (WORKING) GAS INLET PRESSURE

Set up the boiler to operate at maximum rate by referring to Frame 39, Service Mode Maximum Rate. this mode will operate the boiler at maximum heat output but in central heating mode. to ensure the boiler is operating at maximum this must be carried out when the system is cool.

With the boiler operating in the maximum rate condition check that the operational (working) gas pressure at the inlet gas pressure test point complies with the requirements - refer to "Gas Supply" on page 8.

Ensure that this inlet pressure can be obtained with all other gas appliances in the property working.

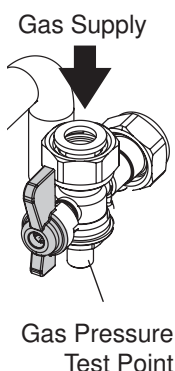

ATTENTION !
IT IS A CONDITION OF THE MANUFACTURERS WARRANTY THAT THE BENCHMARK COMMISSIONING CHECKLIST IS FULLY COMPLETED AND LEFT WITH THE APPLIANCE

INSTALLATION

33 INITIAL LIGHTING

Legend

- A. Boiler Status
- B. Exit Button
- C. Down Button
- D. Up Button
- E. Enter Button
- F. Reset Button
- G. CH Temperature Control
- H. DHW Temperature Control and Off Switch
- J. Burner On indication
- K. Pressure Gauge
- L. Boiler in Full Condensing Mode
- M. CH Flow Isolating Valve
- N. Gas Inlet Pressure Test Point
- P. Gas Service Cock
- Q. DHW Inlet Valve
- R. CH Return Isolating Valve
- S. DHW Outlet

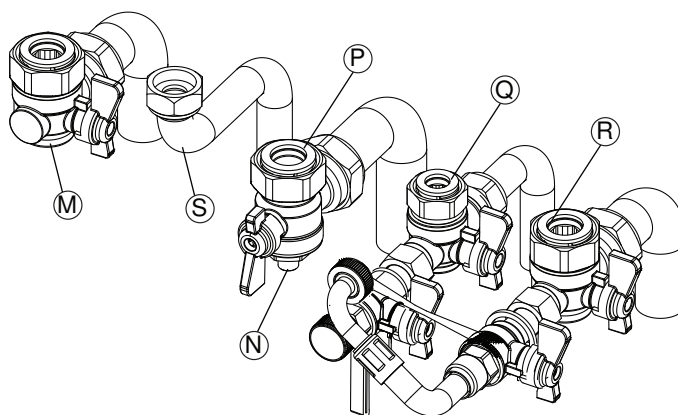
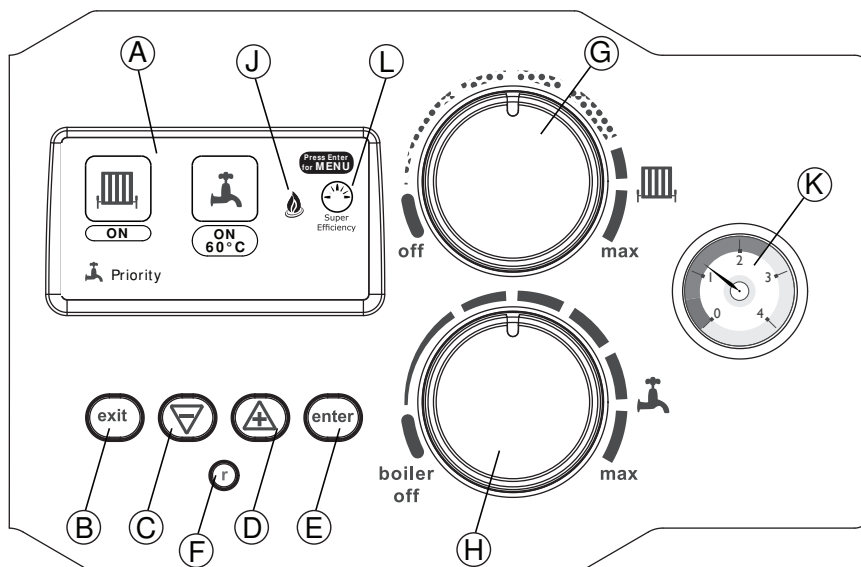

PREPARATION FOR IGNITION

1. Check that the electrical supply is OFF.
2. Check that the system has been filled and that the boiler is not air locked.
3. Ensure that the automatic air vent cap is open. Refer to Frame 70.
4. To assist with venting the air from the system, refer to Frame 37 Vent System. This function operates the boiler to ensure efficient venting of the boiler and system.
5. Refit the boiler front panel. Refer to Frame 45.
6. Check that the drain cock is closed and that the CH (M & R) and DHW (Q) isolating valves are OPEN.
7. Check that the DHW Temperature Control Knob (H) is turned fully anti-clockwise into the off position.
8. Check that the gas service cock (P) is OPEN.
9. Slacken the screw in the inlet pressure test point (N) and connect a gas pressure gauge via a flexible tube.

INITIAL IGNITION

1. Switch the electricity supply ON and check all internal and external controls are calling for heat.
2. Set the CH Temperature Control (G) to max and set the DHW Temperature Control (H) to max. The boiler will now go through its ignition sequence until the burner is established.
3. If the boiler has not lit, after 5 ignition attempts, the following screen will be displayed.

Ignition Lockout

Check other Gas Appliances work
If not, re-instate gas supply
Reset boiler by pressing r
If fault persists contact installer

4. Reset the boiler and the ignition sequence will be repeated. If reset occurs 5 times within 15 minutes then the following screen will be displayed.

Too Many Resets

Contact Installer

If power is removed this will be reset.

34 CHECK CH & DHW OPERATION

CENTRAL HEATING

When the burner is established the following screen will be displayed.

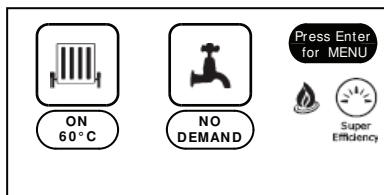

The temperature shown will be the actual Flow Temperature.

Set the timer or Programmable Room Stat to be off. The burner will go off and the fan and pump continue to run for 2 minutes. The following screen will be displayed.

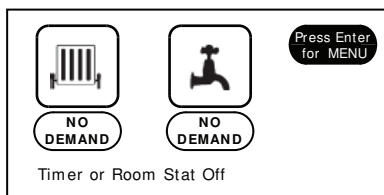

Check the correct operation of all the system controls by operating each control separately and check that the main burner responds.

DOMESTIC HOT WATER

Fully open a DHW tap. The boiler will continue to run and the following screen will be displayed.

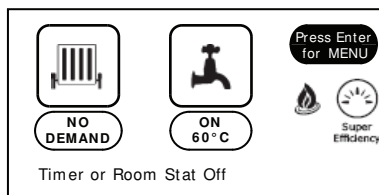

The temperature shown will be the actual DHW temperature.

Close all taps except the largest draw off (bath) and check that the boiler is firing in DHW. This is factory set to give a DHW temperature rise of approximately 35°C at the flow rate stated on page 6 under "operation".

At full DHW output check the gas rate at the gas meter with no other appliances in use. Refer to page 9 for gas rates. Ensure that, with the boiler operating, the dynamic gas pressure is able to obtain maximum output. Refer to Table 1.

Note. to achieve maximum output in DHW operation all taps may need to be opened.

Fully open all DHW taps in turn and ensure that water flows freely.

Reduce the DHW draw off rate to about 3 l/min (0.7gpm) and check that the boiler modulates to deliver DHW at approximately 64°C (with the DHW temperature control knob set to maximum).

Close the DHW tap and check that the main burner extinguishes. The pump will overrun for 60 seconds while the fan overruns for 2 minutes. The following screen will be displayed.

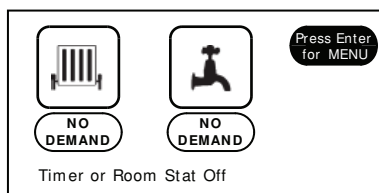

IMPORTANT

The gas input to the burner is regulated by the gas valve according to the air flow produced by the fan. It is NOT user-adjustable. Any interference to sealed settings on the gas valve will adversely affect operation and render warranty void. For additional information refer to "Gas Supply" on page 8.

Note: on systems in excess of 2 bar inlet pressure, a water pressure governor may be required to prevent water noise.

INSTALLATION

35 DISPLAY FUNCTIONS IN NORMAL OPERATION

Boiler Switched Off:
DHW Knob in Off Position

Turn dial for Heating or Hot Water

DHW Demand Off:
CH Knob in Off Position

Turn dial for Heating

DHW Demand On:
CH Knob in Off Position

Turn dial for Heating

DHW Demand Off,
CH Demand Off

Timer or Room Stat Off

DHW Demand On,
CH Demand Off

Timer or Room Stat Off

DHW Demand On,
CH Demand On

Priority

DHW Demand Off,
CH Demand On

Pre-heat Demand On

Turn dial for Heating

Boiler Frost Protection:
occurs if Flow
Temperature less than
5°C

Boiler Frost Protection
Switch Off Temperature: 19°C

System Frost Protection:
occurs if
Outside Sensor connected
& Outside Temp' < 5°C &
System Frost Protection
selected in Menu

System Frost Protection
Go to MENU to disable

Service Due:
shown after 12 months
operation, see Frame 33
to reset

Turn dial for Heating
Service Due
Phone
01482 498660

36 CHANGING SETTINGS

To change the DHW Temperature Set Point

Rotate the DHW Temperature Control Knob, the screen on the right will be shown

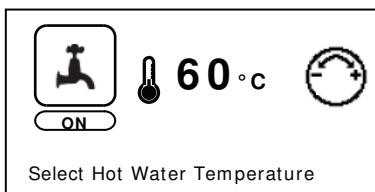

To change the Flow Temperature Set Point:

Rotate the CH Temperature Control Knob, the screen on the right will be shown

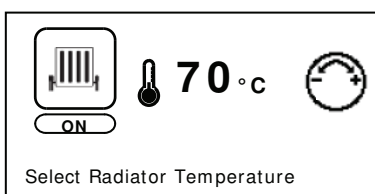

To switch CH function ON:

Rotate the CH Temperature Control Knob clockwise, the screen on the right will be shown

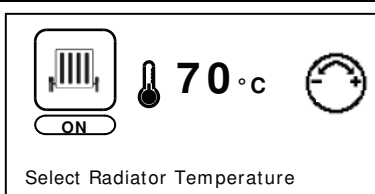

To switch the CH function OFF:

Rotate the CH Temperature Control Knob fully anti-clockwise, the screen on the right will be shown

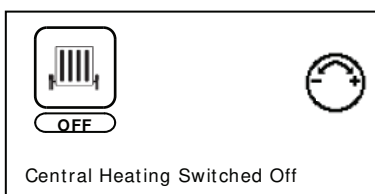

To disable DHW and CH:

Rotate the DHW Temperature Knob fully anti-clockwise, the screen on the right will be shown (frost protection still active)

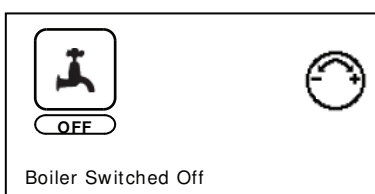

To switch the boiler On:

Rotate the DHW Temperature Knob clockwise, the screen on the right will be shown

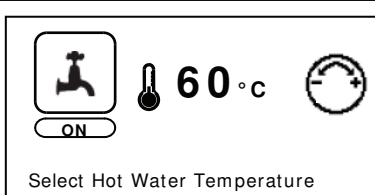

To change the Room Temperature Set Point

(only if Outside Sensor connected): rotate the CH Temperature Knob, the screen on the right will be shown

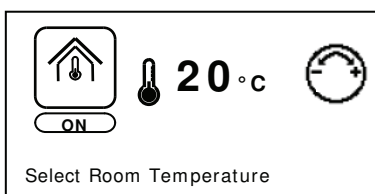

37 MENU OPERATION

VENT SYSTEM

The Vent System feature aids removal of air from the heat exchanger. The pump will be switched on for 50s and then off for 10s while the diverter valve is moved between DHW and CH every 30s. The feature lasts for 5 minutes.

Press ENTER and the following screen will be displayed

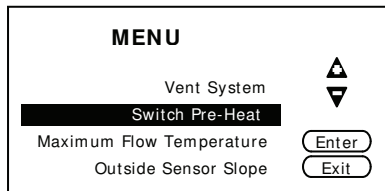

Press “+” and the following screen will be displayed.

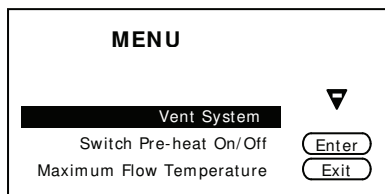

Press ENTER and the following screen will be displayed.

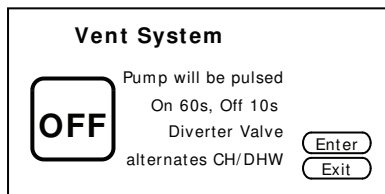

Press ENTER and the following screen will be displayed.

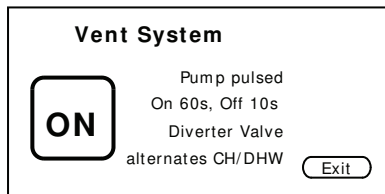

The feature will end automatically after 5 minutes, to end manually press EXIT.

PRE-HEAT

If pre-heat is switched on then the boiler will periodically fire the burner thereby reducing the time taken to provide hot water. If pre-heat is switched off the response time will be reduced although gas consumption will also be reduced.

Press ENTER and the following screen will be displayed

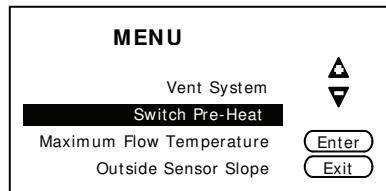

Press ENTER and a screen similar to the following will be displayed.

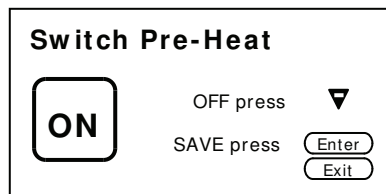

To switch Pre-heat off press “-“

To switch Pre-heat on press “+“

To return to normal operation press EXIT twice.

MAXIMUM FLOW TEMPERATURE

It is possible to limit the maximum flow temperature that can be set from the CH Flow Temperature knob using this feature. Note that this could prevent adequate room temperature being achieved in winter.

Press ENTER and the following screen will be displayed.

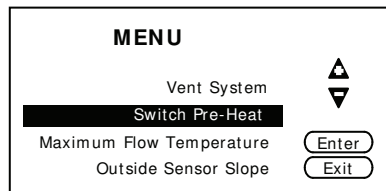

Press “-“ until the following screen is displayed.

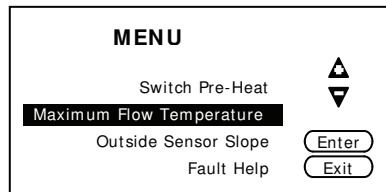

Press ENTER and a screen similar to following will be displayed.

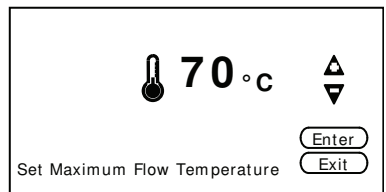

Press “+“ and “-“ until the desired temperature is displayed and then ENTER followed by EXIT to return to normal operation.

38 MENU OPERATION

OUTSIDE SENSOR SLOPE

This feature is only accessible if an Outside Sensor has been fitted to the boiler. Boiler performance can be adjusted relative to the insulation level of the building. To change the slope press ENTER and the following screen will be displayed

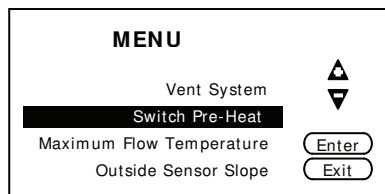

Press “-” until the following screen is displayed.

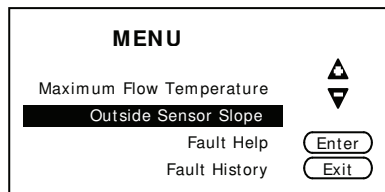

Press ENTER and the following screen will be displayed.

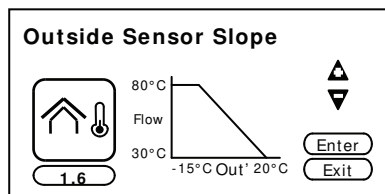

Press “+” and “-” until the desired setting is displayed.
Press ENTER followed by EXIT to return to normal operation.

FAULT HELP

This feature provides a list of potential corrective actions at an installer level for all faults detectable by the boiler electronics. Press ENTER and the following screen will be displayed

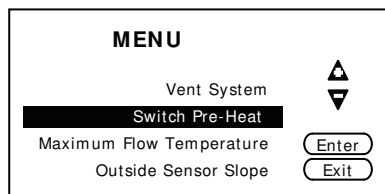

Press “-” until the following screen is displayed.

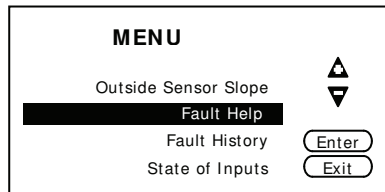

Press ENTER and the following screen will be displayed.

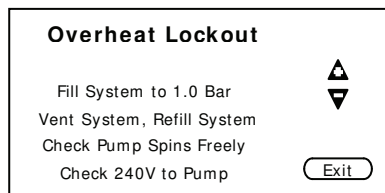

Press “+” and “-” to scroll through the information.
Press EXIT twice to return to normal operation.

FAULT HISTORY

To view the Fault History of the boiler press ENTER and the following screen will be displayed

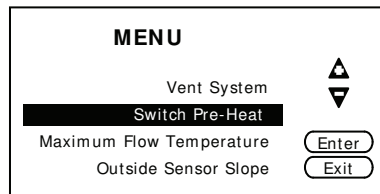

Press “-” until the following screen is displayed.

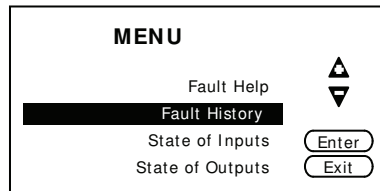

Press ENTER and a screen similar to the following will be displayed.



Press “+” and “-” to view the full list.
Press EXIT twice to return to normal operation.

STATE OF INPUTS

To view the current Water Pressure, Switched Live Status, DHW Flow Rate, DHW Temperature, Flow Temperature, Return Temperature, Flame Status, Outside Temperature, DHW Switched Live Status and OpenTherm Status press ENTER and the following screen will be displayed.

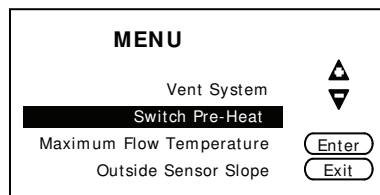

Press “-” until the following screen is displayed.

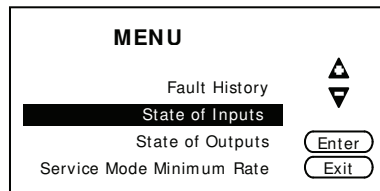

Press ENTER and a screen similar to following will be displayed.

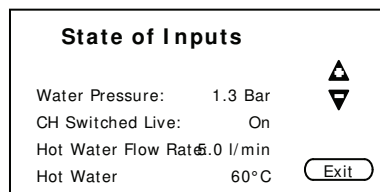

Press “+” and “-” to view the full list.
Press EXIT twice to return to normal operation.

39 MENU OPERATION

STATE OF OUTPUTS

To view the current status of the Pump, Diverter Valve, Fan, Spark Generator and Gas Valve press ENTER and the following screen will be displayed.

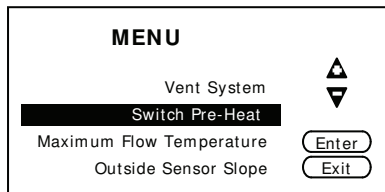

Press "-" until the following screen is displayed.

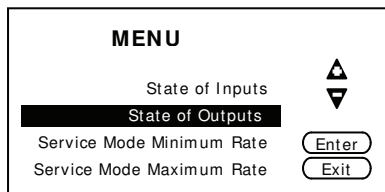

Press ENTER and a screen similar to the following will be displayed.

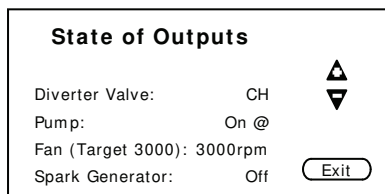

Press "+" and "-" to view the full list.

Press EXIT twice to return to normal operation.

SERVICE MODE MINIMUM RATE

This feature will run the burner at minimum rate. Note that a CH demand has to already be present for the feature to be active. To activate the feature press ENTER and the following screen will be displayed.

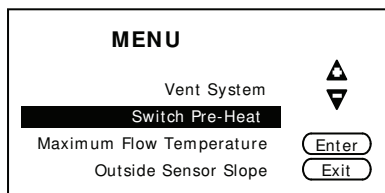

Press "-" until the following screen is displayed.

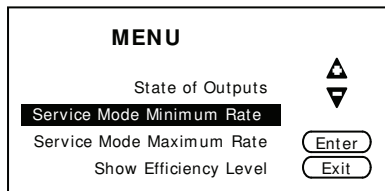

Press ENTER and the following screen will be displayed.

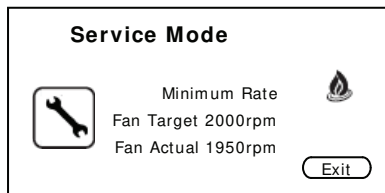

Press EXIT twice to return to normal operation.

SERVICE MODE MAXIMUM RATE

This feature will run the burner at maximum rate. Note that a CH demand has to already be present for the feature to be active. Gas rate will reduce as flow temperature approached 80°C. To activate the feature press ENTER and the following screen will be displayed.

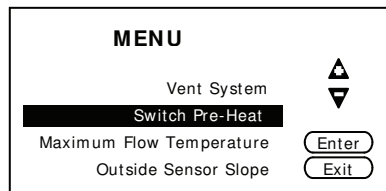

Press "-" until the following screen is displayed.

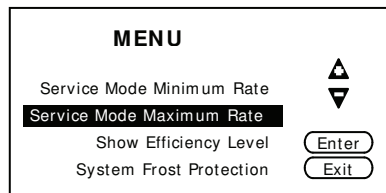

Press ENTER and the following screen will be displayed.

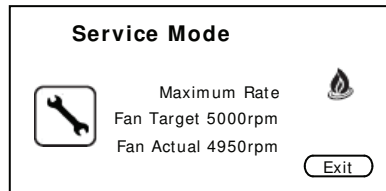

Press EXIT twice to return to normal operation.

EFFICIENCY LEVEL

To view the efficiency level of the boiler press ENTER and the following screen will be displayed.

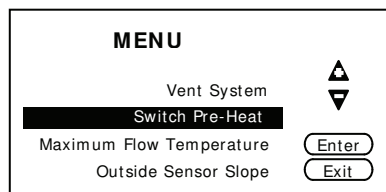

Press "-" until the following screen is displayed.

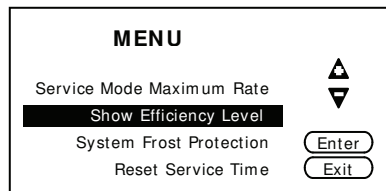

Press ENTER and a screen similar to following will be displayed.

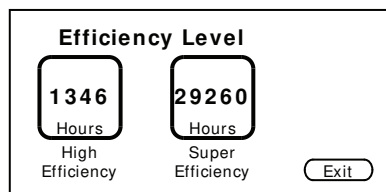

Press EXIT twice to return to normal operation.

40 MENU OPERATION

SYSTEM FROST PROTECTION

This feature can only be accessed if an outside sensor has been connected. The pump will run continuously if the outside temperature is less than 5°C.

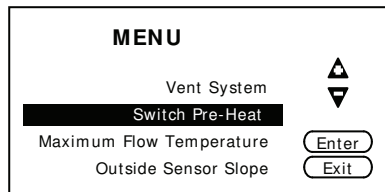

Press “-” until the following screen is displayed.

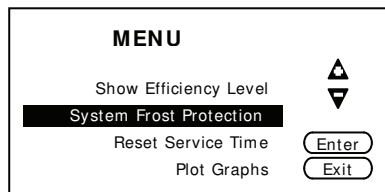

Press ENTER and a screen similar to the following will be displayed.

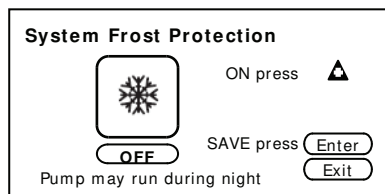

Press “+” to activate or “-” to de-activate.
Press EXIT twice to return to normal operation.

RESET SERVICE TIME

If the boiler has not been serviced within the last 12 months then a message will be displayed indicating this. To reset this timing proceed as follows.

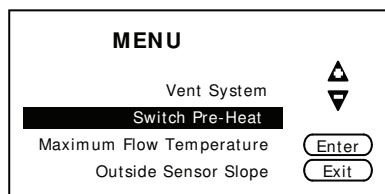

Press “-” until the following screen is displayed.

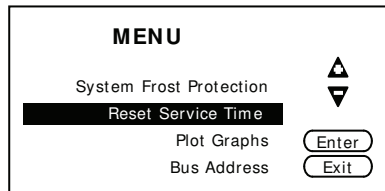

Press ENTER and the following screen will be displayed.



Press ENTER to reset.
Press EXIT to return to normal operation.

PLOT GRAPHS

To plot graphs of Water Pressure, Switched Live, DHW Flow Rate, DHW Temperature, Flow/Return Temperature, Flame Status, Outside Temperature or DHW Switched Live press ENTER and the following screen will be displayed.

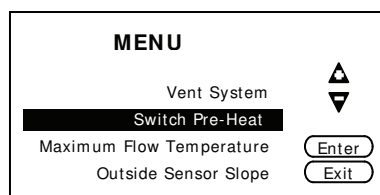

Press “-” until the following screen is displayed.

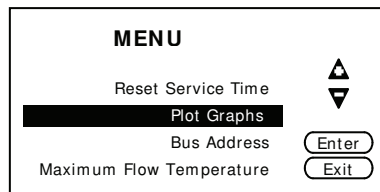

Press ENTER and the following screen will be displayed.

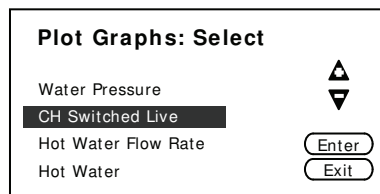

Press “+” & “-” to highlight the desired input and then ENTER to select. Press EXIT 3 times to return to normal operation.

BUS ADDRESS

This feature is only required if the boiler is connected to an Ideal Cascade Manager (available 2014). Each boiler in the cascade should be configured to a different bus address. To change the bus address press ENTER.

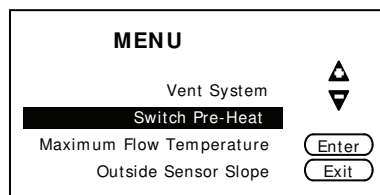

Press “-” until the following screen is displayed.

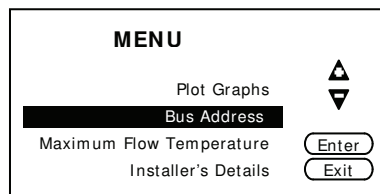

Press ENTER and a screen similar to following will be displayed.

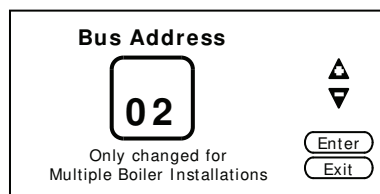

Press “+” or “-” to change the address.
Press ENTER and then EXIT to return to normal operation.

41 MENU OPERATION

INSTALLER'S DETAILS

The service required message which is displayed after 12 months can be customised to show the installer's telephone number. To record your telephone number press ENTER and the following screen will be displayed.

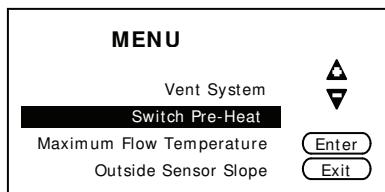

Press "-" until the following screen is displayed.

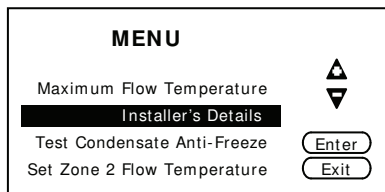

Press ENTER and a screen similar to the following will be displayed.



Press "+" and "-" to change the number and ENTER to accept. Press EXIT twice to return to normal operation.

TEST CONDENSATE ANTI-FREEZE

If Ideal's optional condensate anti-freeze kit has been fitted to the boiler then to test operation press ENTER and the following screen will be displayed.

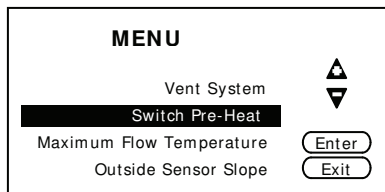

Press "-" until the following screen is displayed.

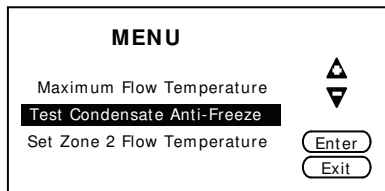

Press ENTER and the following screen will be displayed.

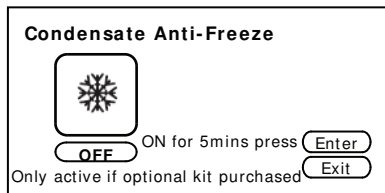

Press ENTER to activate. Press EXIT twice to return to normal operation.

SET ZONE 2 FLOW TEMPERATURE

If a second switched live is connected to the boiler for a second zone (see Frame 30) then the flow temperature target for this zone can be set independently. Press ENTER and the following screen will be displayed.

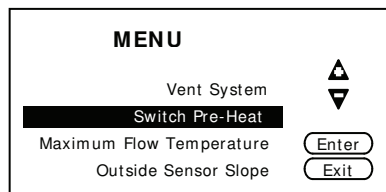

Press "-" until the following screen is displayed.

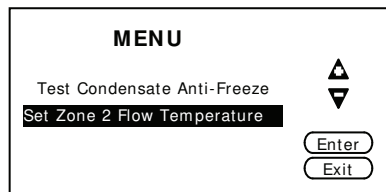

Press ENTER and the following screen will be displayed.

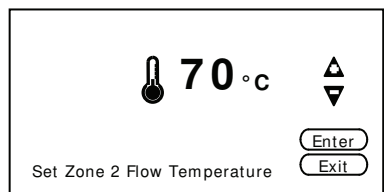

Press "+" & "-" to change the temperature to the require setting and then ENTER. Press EXIT to return to normal operation.

PUMP MODULATION

The boiler is factory set for pump operation to give maximum reliability. If the CH system has been fully balanced then pump modulation can be increased to reduce electrical energy consumption, to do so press ENTER and the following screen is displayed.

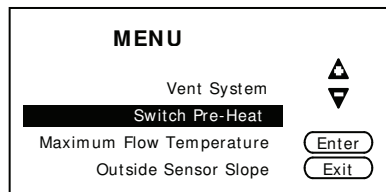

Press "-" until the following screen is displayed.

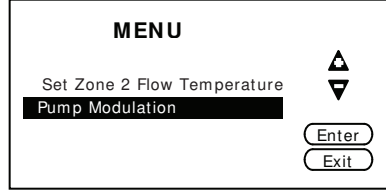

Press ENTER and the following screen will be displayed.

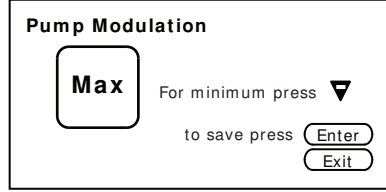

Press "-" to change the setting and then ENTER. Press Exit to return to normal operation.

42 GENERAL CHECKS

WATER CIRCULATION SYSTEM

1. With the system COLD, check that the initial pressure is correct to the system design requirements.

For pre-pressurised systems, this should be 1.0 bar.

2. With the system HOT, examine all water connections for soundness. The system pressure will increase with temperature rise but should not exceed 2.5 bar.
3. With the system still hot, turn off the gas, water and electricity supplies to the boiler and drain down to complete the flushing process.

Note: A flushing solution should be used during the flushing procedure. Flushing solutions: Fernox F3 or DS40, Sentinel X300 (new systems) or X400 (existing systems).

4. Refill and vent the system, add inhibitor (see Frame 24), clear all air locks and again check for water soundness.
5. Reset the system initial pressure to the design requirement.
6. Balance the system. Refer to Frame 4.
7. Check the condensate drain for leaks and check that it is discharging correctly.

8. Finally, set the controls to the User's requirements.

Notes.

1. *If the pump has not operated in the last 24 hours it will run briefly to prevent seizure*
2. *If the diverter valve has not operated in the last 24 hours it will be operated briefly to prevent seizure. These two operations will not occur at the same time.*

WATER TEMPERATURES

Temperatures can be selected using the CH and DHW thermostats.

Knob Setting	CH Flow Temp °C (°F)	DHW Outlet Temp °C (°F)
Max	80 (176)	65 (149)
Min	30 (86)	40 (104)

43 HANDING OVER

After completing the installation and commissioning of the system the installer should hand over to the householder by the following actions:

1. Make the householder aware that the user instructions are located in the pocket in the drop down door and explain his/her responsibilities under the relevant national regulations.
2. Explain and demonstrate the lighting and shutting down procedures.
3. The operation of the boiler and the use and adjustment of all system controls should be fully explained to the householder, to ensure the greatest possible fuel economy consistent with the household requirements of both heating and hot water consumption.

Advise the User of the precautions necessary to prevent damage to the system and to the building, in the event of the system remaining inoperative during frosty conditions.

4. Explain the function and the use of the boiler heating and domestic hot water controls.

Explain that due to system variations and seasonal temperature fluctuations DHW flow rates/temperature rise will vary, requiring adjustment at the draw off tap. It is therefore necessary to draw the users attention to the section in the Users Instructions titled "Control of Water Temperature" and the following statement:

"Additionally, the temperature can be controlled by the user via the draw-off tap: the lower the rate the higher the temperature, and vice versa".

5. Explain the function of the boiler fault mode.
Emphasise that if a fault is indicated, the boiler should be turned off and a Gas Safe Registered Engineer consulted. In IE contact a Registered Gas Installer (RGII).
6. Explain and demonstrate the function of time and temperature controls, radiator valves etc., for the economic use of the system.
7. If a timer is fitted draw attention to the timer Users Instructions and hand them to the householder.

8. Loss of system water pressure

Explain that the dial at the front RHS of the boiler indicates the central heating system pressure and that if the normal COLD pressure of the system is seen to decrease over a period of time then a water leak is indicated. Explain the re-pressurising procedure and if unable to re-pressurise or if the pressure continues to drop a registered local heating installer should be consulted.

9. Explain boiler reset procedure (refer to Frame 32).

10. After installation and commissioning please complete



the Commissioning Checklist before handover to the customer. For IE, its is necessary to complete a "Declaration of Conformity" to indicate compliance to I.S. 813:2002.

IMPORTANT

11. A comprehensive service should be carried out ANNUALLY.

Stress the importance of regular servicing by a Gas Safe Registered Engineer. In IE servicing work must be carried out by a Registered Gas Installer (RGII).

12. Inform the householder of the guarantee/registration found within the envelope pack and the requirement to register it to receive the full benefit of the warranty.

44 SERVICING SCHEDULE

For the very latest copy of literature for specification & maintenance practices, visit our website www.idealboilers.com, where you will be able to download the relevant information. N.B. Technical Bulletins are also available on www.idealboilers.com.

WARNING. Always turn OFF the gas supply at the gas service cock, and switch OFF and disconnect the electricity supply to the appliance before servicing.

Combustion testing must be carried out by a competent person using a combustion analyser conforming to BS7927.

To ensure the continued safe and efficient operation of the appliance it is recommended that it is checked at regular intervals and serviced as necessary. The frequency of servicing will depend upon the installation condition and usage but should be carried out at least annually.

It is the law that any service work must be carried out by a Gas Safe Registered Engineer. In IE service work must be carried out by a Registered Gas Installer (RGII).

INSPECTION

1. Light the boiler and carry out a pre-service check, noting any operational faults.
2. Check the flue terminal (and terminal guard if fitted) is undamaged and clear of any obstruction.
3. Check all water and gas joints for signs of leakage. Remake any suspect joints ensuring a gas tightness check is carried out if applicable and the water system is correctly refilled, vented and re-pressurised.

CLEANING PROCEDURE

Note. In order to carry out either servicing or replacement of components the boiler front panel must be removed. Refer to Frame 45.

1. Clean the main burner. Refer to Frame 49.
2. Clean the heat exchanger & condensate trap/siphon. Refer to Frames 50 & 51.
3. Check the main injector for blockage or damage. Refer to Frame 48.
4. Check that the flue terminal is unobstructed and that the flue system is sealed correctly.

ALSO IF THE DHW FLOW RATE IS IN QUESTION :-

5. Check the DHW filter for blockage. Refer to Frame 76.

The cleaning procedures are covered more fully in Frames 45-51 and MUST be carried out in sequence.

IMPORTANT.

6. After completing the servicing or exchange of components always test for gas tightness.
7. When work is complete the front panel MUST be correctly refitted, ensuring that a good seal is made.

Do NOT OPERATE the boiler if the front panel is not fitted.

8. If, for any reason, the condensate trap/siphon has been removed ensure the trap is refilled with water before reassembling.
9. Check the gas consumption.
10. Check combustion by connecting the flue gas analyser to the flue gas sampling point as shown in the diagram and measure CO & CO₂.

If the CO/CO₂ ratio is greater than 0.004 AND the integrity of the complete flue system and combustion circuit seals have been verified and the inlet gas pressure (and gas rate) have been verified, then contact Ideal.

11. Complete the service section in the Benchmark Commissioning Checklist.

GENERAL

Please Note: During routine servicing, and after any maintenance or change of part of the combustion circuit, the following must be checked:

- The integrity of the flue system and the flue seals,
- The integrity of the boiler combustion circuit and the relevant seals
- The operational (working) gas inlet pressure at maximum rate.
- The gas rate
- The combustion performance.

COMPETENCE TO CARRY OUT THE CHECK OF COMBUSTION PERFORMANCE

Please Note: BS 6798:2009 Specification for installation and maintenance of gas-fired boilers of rated input not exceeding 70kW net advises that:

- The person carrying out a combustion measurement should have been assessed as competent in the use of a flue gas analyser and the interpretation of the results.
- The flue gas analyser used should be one meeting the requirements of BS7927 or BS-EN50379-3 and be calibrated in accordance with the analyser manufacturers requirements, and
- Competence can be demonstrated by satisfactory completion of the CPA1 ACS assessment, which covers the use of electronic portable combustion gas analysers in accordance with BS7967, Parts 1 to 4.

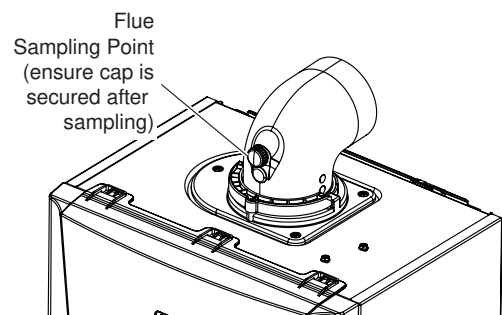

45 BOILER FRONT PANEL REMOVAL / REPLACEMENT

REMOVAL

1. Loosen the 2 screws retaining the front panel at the bottom.
2. Release catches at rear of door by pulling downwards.
3. Pull the underside front panel forward then lift upwards to remove.

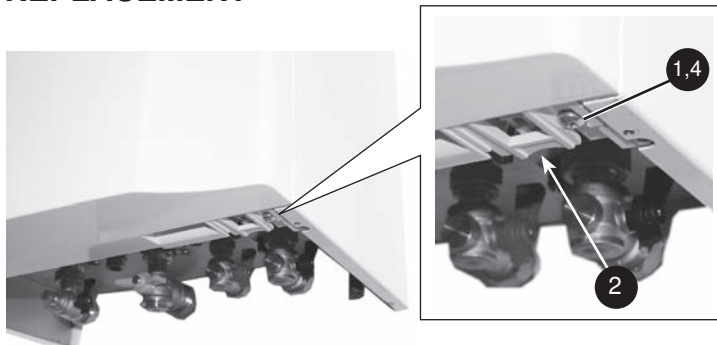

REPLACEMENT

3. Engage the top of the front panel on the locating lugs and push the panel back into position engaging the securing screws
4. Re-tighten the securing screws.

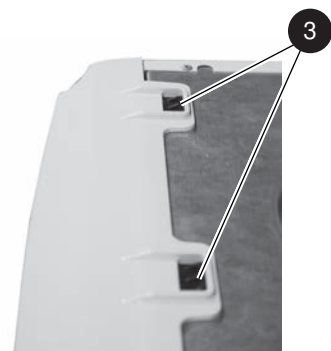

46 LOWERING THE CONTROLS PANEL

1. Once the front panel has been removed the controls panel can be hinged down to access the wiring and electronics or the internal components of the boiler.
2. To lower the panel further (position 2) squeeze the 2 clips inward and hinge the panel into a lower position.
3. To gain access to the mains wiring connection squeeze the 2 lugs together and remove the cover.

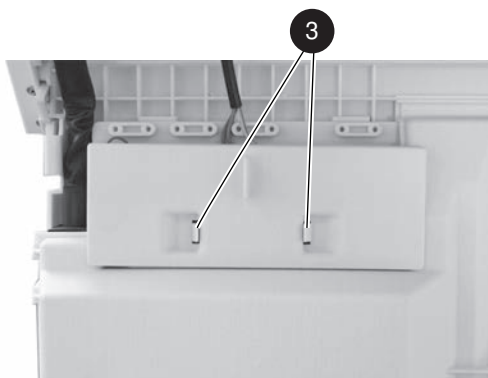
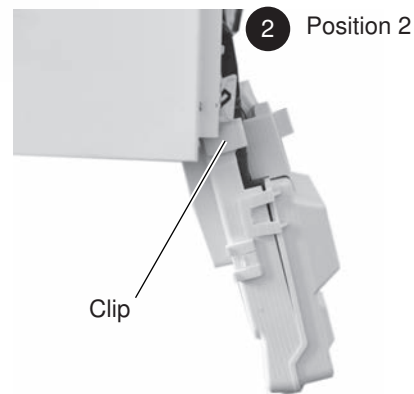
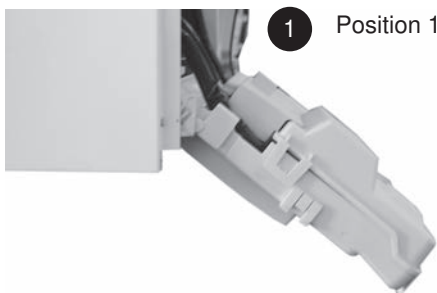

47 FAN AND VENTURI ASSEMBLY REMOVAL AND CLEANING

1. Refer to Frame 45 & 46.
 2. Remove the ignition, detection and earth leads.
 3. Remove the 2 clips securing the gas inlet pipe and remove the pipe.
 4. Remove the fan leads.
 5. Remove the 4 securing nuts retaining the burner/ fan assembly.
 6. Remove the assembly from the heat exchanger.
 7. To remove the venturi release the 2 securing screws to gain access for cleaning.
 8. When replacing check the sealing gasket is undamaged or replace as necessary, and secure with the 2 screws.
- *Note a noise damper is fitted to the venturi inlet on c40 models
9. To remove the fan, first remove the venturi as above and release the 3 screws securing the fan to the burner. (Note a mounting spacer is fitted to the fan outlet on c40 model only)
 10. Remove the fan from the burner assembly. When replacing check the sealing gasket is undamaged or replace as necessary, and secure with the 3 screws.

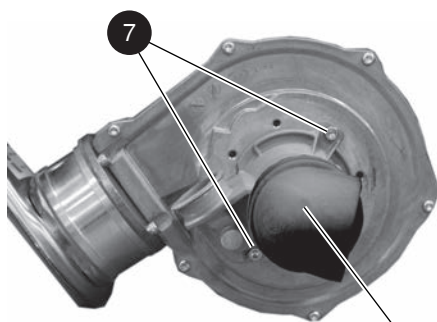
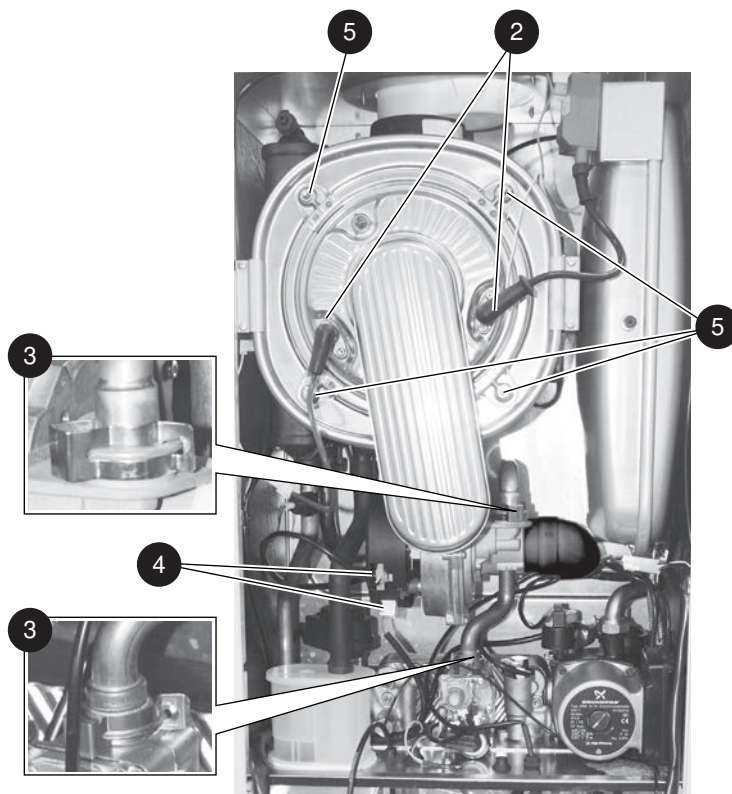

Noise Damper
Fitted only to c40
& c32 models

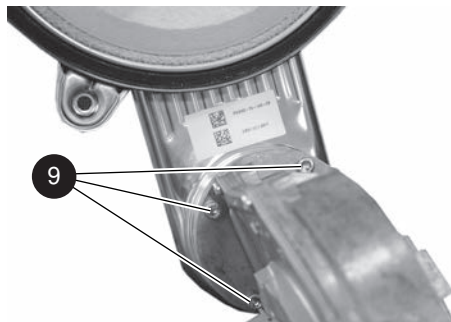

Mounting Spacer
Fitted only to c40

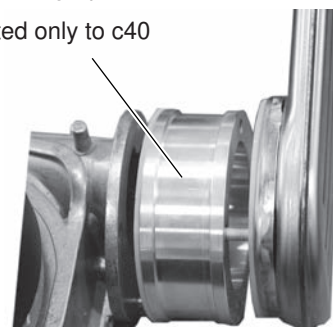

48 REMOVAL OF INJECTOR

1. Refer to Frames 45 & 46.
2. Refer to Frame 53.
3. Remove the 2 clips securing the gas inlet pipe and remove the pipe (as point 3 above).
4. Carefully ease the injector out of the gas valve.
5. Examine or clean as necessary
6. Re-fit in reverse order ensuring the sealing o ring is in good condition or replace if necessary.
7. Refit the gas pipe ensuring the seals are in good condition and correctly located & secure with clips.

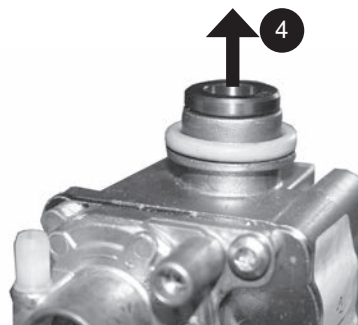

49 BURNER REMOVAL AND CLEANING

1. Remove Fan and Venturi Assembly, Refer to Frame 46.
2. Remove the ignition, detection and earth leads.
3. Remove the 2 clips securing the gas inlet pipe and remove the pipe.
4. Remove the fan leads.
5. Remove the 4 securing nuts from the heat exchanger.
6. Remove the assembly from the heat exchanger.
7. Brush off any deposits with a SOFT brush
- 8a. Inspect the burner door sealing gaskets and insulation for signs of damage. Replace as necessary.

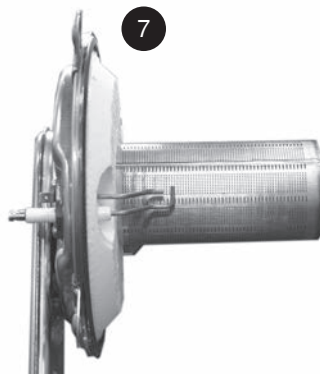

Replacement of burner door sealing gasket

- 8b. Remove the silicon seal from around the burner door location groove.
9. Re-new the seal and replace in reverse order.

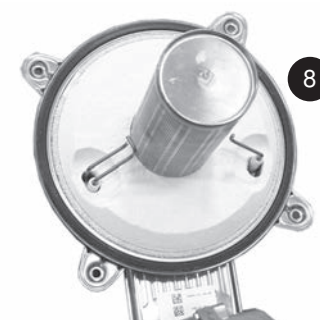

50 CLEANING THE CONDENSATE TRAP / SIPHON

1. Remove the rubber condensate pipe from the top of the trap.
2. Rotate the trap clockwise to disengage the trap and lift clear of the outlet connection.
3. Flush out any debris under running water
4. Refit in reverse order making sure the trap is engaged with the outlet connection.
5. Fill the trap with water before operating the boiler.



51 CLEANING THE HEAT EXCHANGER

1. Remove Fan and Venturi Assembly, Refer to Frame 47.
2. Once the front of the heat exchanger is open, the heat exchanger may be cleaned with a hand brush and vacuum cleaner to remove any debris.

2

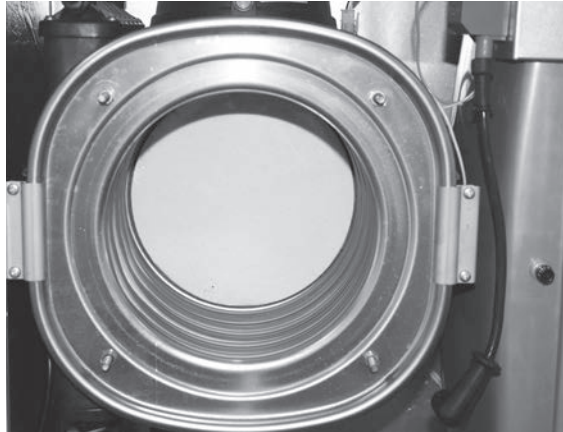

52 RE-ASSEMBLY

1. Reassemble the boiler in the following order:
2. Ensure the condensate trap is engaged in the base of the boiler and connected to the outlet with the pipe from the heat exchanger connected.
3. Refit the fan to the burner assembly. Refer to Frame 47.
4. Refit the venturi to the fan and burner assembly. Refer to Frame 57.
5. Refit the burner/fan/venturi assembly into the heat exchanger and secure. Refer to Frame 51.
6. Refit the gas pipe and secure with the 2 clips. Refer to Frame 47.
7. Reconnect the ignition/detection/earth/fan leads
8. Swing the control panel back into its working position. Refer to Frame 46.
9. Refit the front panel ensuring that a good seal is made. Refer to Frame 45.
10. Turn on the gas supply at the gas service cock. Refer to Frame 33.
11. Reconnect the electrical supply.
12. Check the operation of the boiler.

53 REPLACEMENT OF COMPONENTS

When replacing ANY component

1. Isolate the electrical supply
2. Isolate the water connections
3. Turn off the gas supply
4. Remove the front panel
5. Swing the control panel down into the service position

After replacing ANY component check operation of the boiler, including gas tightness, gas rate and combustion test.

IMPORTANT. when work is complete, the front panel must be correctly refitted - ensuring that a good seal is made.

THE BOILER MUST NOT BE OPERATED WITHOUT THE FRONT PANEL FITTED.

54 FAN REPLACEMENT

1. Refer to Frames 45 & 46.
2. Refer to Frame 53.
3. Remove the ignition, detection and earth leads.
4. Remove the 2 clips securing the gas inlet pipe and remove the pipe.
5. Remove the fan leads.
6. Remove the 4 securing nuts retaining the burner/fan assembly.
7. Remove the assembly from the heat exchanger.
8. To remove the venturi release the 2 securing screws.
9. To remove the fan release the 3 screws securing the fan to the burner.
10. Replace the fan and refit the venturi checking the sealing gasket is undamaged or replace as necessary, and secure with the 2 screws

**Note a noise damper is fitted to the venturi inlet on c40 and c32 models*

**Note a mounting spacer is fitted to the fan outlet on c40.*

11. Check the operation of the boiler. Refer to Frames 33-36.

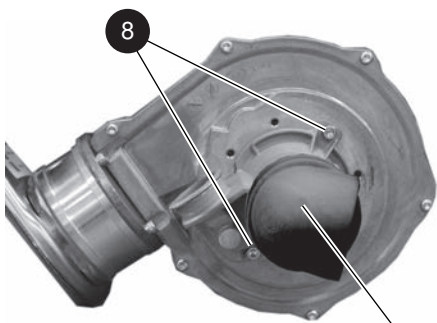
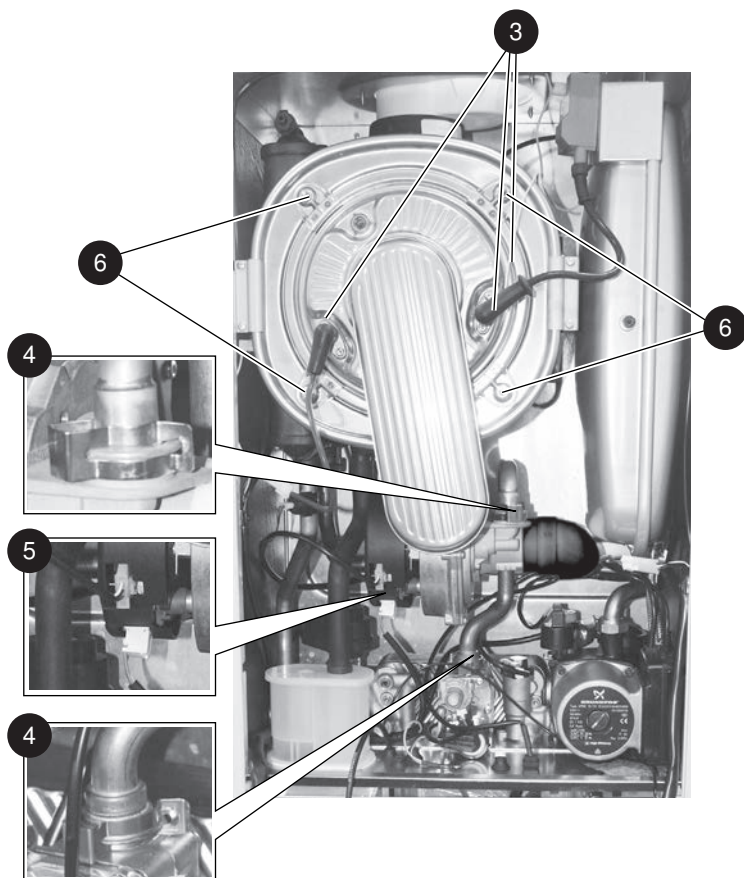

Noise Damper
Fitted only to c40
& c32 models

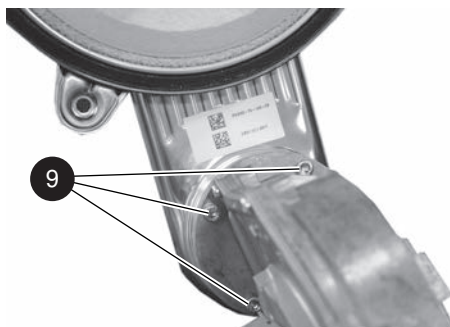

Mounting Spacer
Fitted only to c40

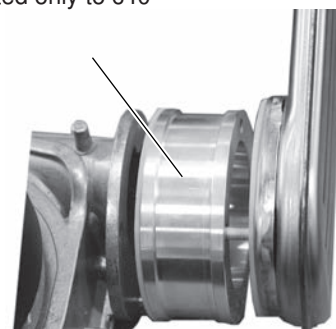

55 BURNER INJECTOR REPLACEMENT

1. Refer to Frames 45 & 46.
2. Refer to Frame 53.
3. Remove the 2 clips securing the gas inlet pipe and remove the pipe.
4. Carefully ease the injector out of the gas valve.
5. Replace injector + 'O' ring.
6. Re-fit in reverse order ensuring the sealing o ring is in good condition or replace if necessary.
7. Refit the gas pipe ensuring the seals are in good condition and correctly located.
8. Secure with the clips.
9. Check the operation of the boiler. Refer to Frames 33-36.

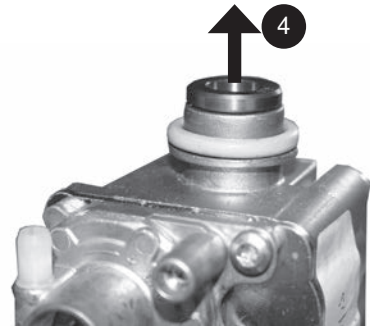

56 BURNER/DOOR ASSEMBLY REPLACEMENT

1. Refer to Frames 45 & 46.
2. Refer to Frame 53.
3. Remove the ignition, detection and earth leads.
4. Remove the 2 clips securing the gas inlet pipe and remove the pipe.
5. Remove the fan leads.
6. Remove the 4 securing nuts retaining the burner/door/fan assembly.
7. Remove the assembly from the heat exchanger
8. To remove the venturi release the 2 securing screws.
9. To remove the fan release the 3 screws securing the fan to the burner/door assembly.
10. Remove the ignition and detection probes.
11. Refit the fan, venturi, ignition probe and detection probe to the new burner/door assembly.
12. Refit in reverse order
13. Check the operation of the boiler. Refer to Frames 33-36.



57 RETURN THERMISTOR RENEWAL

1. Refer to Frames 45 & 46.
2. Refer to Frame 53.
3. Unclip the return thermistor.
4. Disconnect the electrical lead from the thermistor
5. Reconnect the electrical lead to the new thermistor and reassemble in reverse order, ensuring that the thermistor is securely fitted to the pipe on the thermistor locator tabs as shown.
6. Check the operation of the boiler. Refer to Frames 33-36.

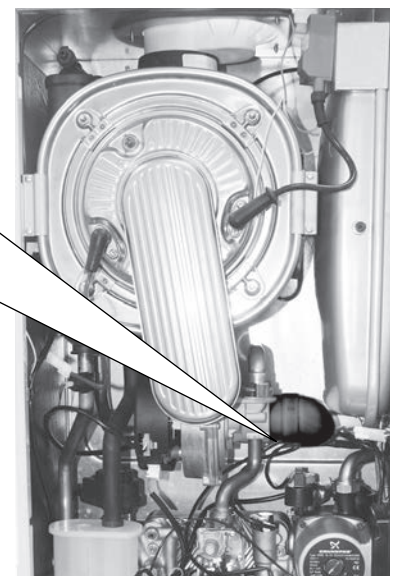
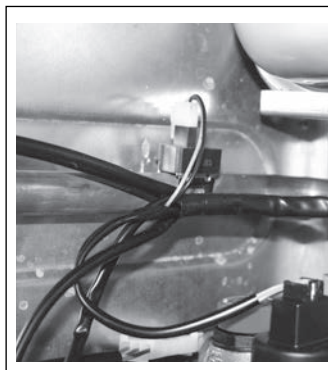

58 IGNITION ELECTRODE REPLACEMENT

1. Refer to Frames 45 & 46.
2. Refer to Frame 53.
3. Disconnect the ignition lead and the earth connection
4. Release the 2 securing screws and carefully withdraw the probe.
5. Check the gap on the replacement ignition electrode is 4.5 ± 0.5 mm.
6. Ensure the sealing gasket is fitted and in good condition
7. Carefully feed the electrode into the burner/door assembly and secure with the 2 screws ensuring correct orientation.
8. Reconnect the lead and earth.
9. Check the operation of the boiler. Refer to Frames 33-36.

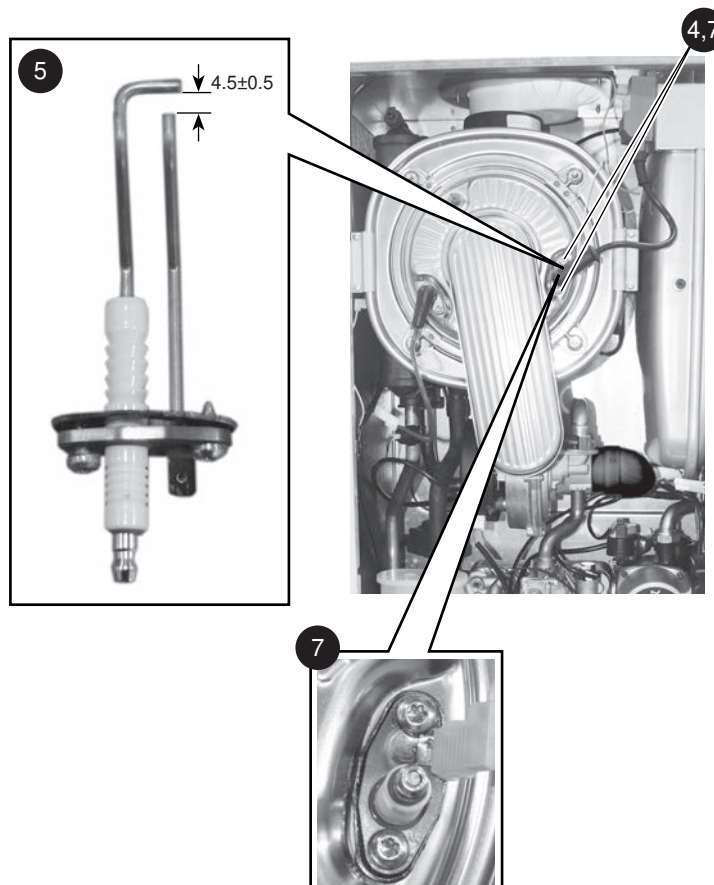

63 FLAME DETECTION ELECTRODE REPLACEMENT

1. Refer to Frames 45 & 46.
2. Refer to Frame 53.
3. Disconnect the detection lead.
4. Release the 2 securing screws and withdraw the probe.
5. Ensure the sealing gasket is fitted to the replacement electrode and in good condition
6. Carefully feed the electrode into the burner/door assembly and secure with the 2 screws ensuring correct orientation.
7. Reconnect the lead
8. Check the operation of the boiler. Refer to Frames 33-36.

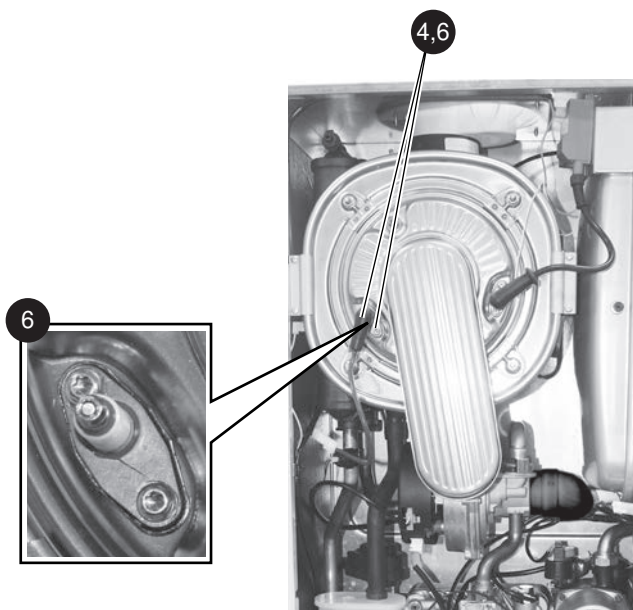

60 SPARK GENERATOR REPLACEMENT

1. Refer to Frames 45 & 46.
2. Refer to Frame 53.
3. Remove the 2 securing screws at the top of the casing, ensuring the expansion vessel is safely supported, and withdraw the spark generator assy.
4. Disconnect the leads from the generator.
5. Remove 2 securing screws.
6. To replace connect all wiring and then fix the generator in position using the 2 securing screws, ensuring the earth lead is firmly fixed under the lower securing screw, and the expansion vessel is correctly located.
7. Secure the spark generator assy using 2 screws in the top of the case.
8. Check the operation of the boiler. Refer to Frames 33-36.

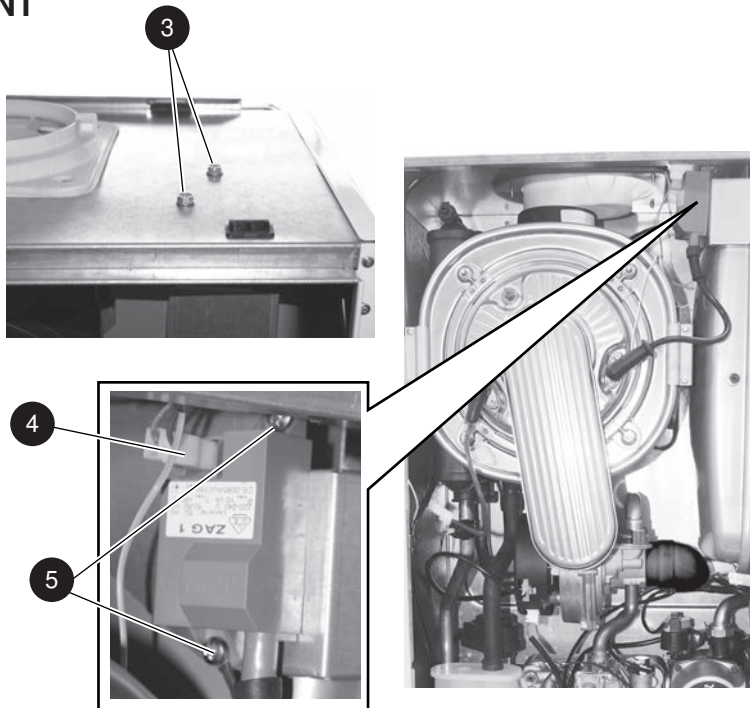

61 GAS CONTROL VALVE REPLACEMENT

1. Refer to Frames 45 & 46.
2. Refer to Frame 53.
3. Remove the gas inlet pipe. Refer to Frame 54.
4. Unplug the electrical connection.
5. Disconnect the earth lead at the rear of the gas valve.
6. Disconnect the gas service valve
7. Remove the 2 securing screws in the underside of the boiler casing and remove the valve.
8. Remove brass injector from gas valve outlet and re-fit into replacement valve.
9. Replace in reverse order ensuring all seals are in good condition and the assembly is gas sound.
10. Check the operation of the boiler. Refer to Frames 33-36.

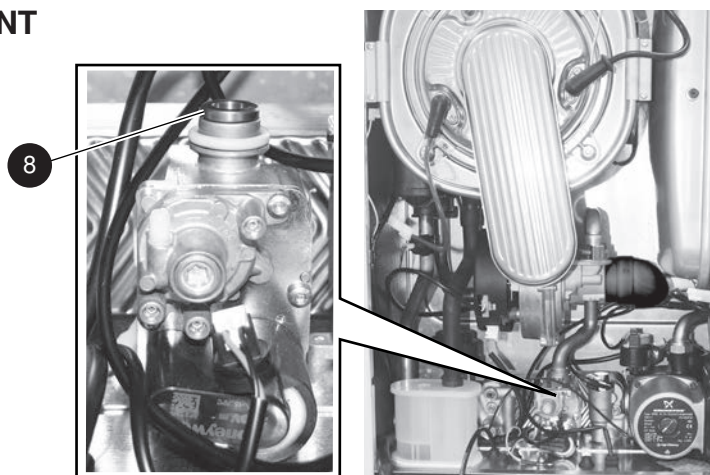

62 DIVERTER VALVE ACTUATOR REPLACEMENT

1. Refer to Frames 45 & 46.
2. Refer to Frame 53.
3. Remove the condense trap. Refer to Frame 50.
4. Disconnect the electrical cable connection
5. Withdraw the securing clip
6. Lift the valve actuator clear of the valve body.
7. Replace in reverse order.
8. Check the operation of the boiler. Refer to Frames 33-36.

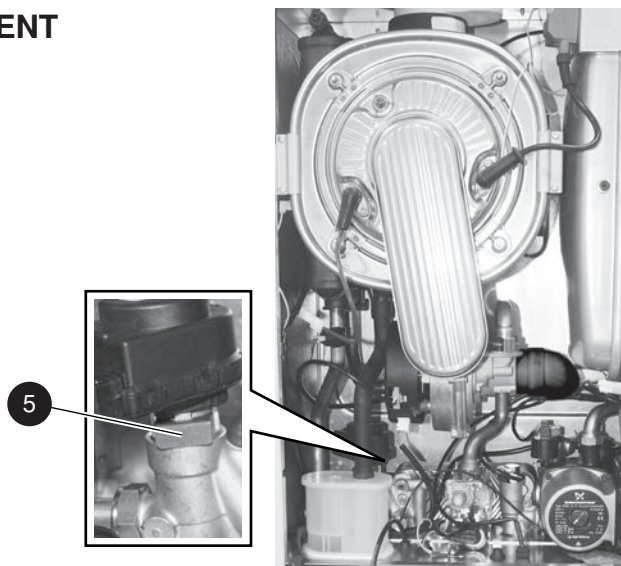

63 CONDENSATE TRAP REPLACEMENT

1. Refer to Frames 45 & 46.
2. Refer to Frame 53.
3. Remove the rubber condensate pipe from the top of the trap.
4. Rotate the trap clockwise to disengage the trap and lift clear of the outlet connection.
5. Refit in reverse order making sure the trap is engaged with the outlet connection
6. Refill the condensate trap.
7. Check the operation of the boiler. Refer to Frames 33-36.

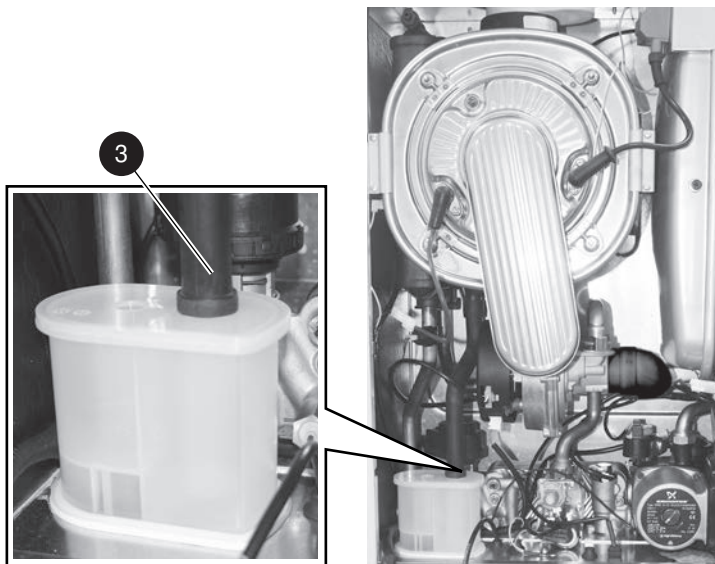

64 MAIN PCB REPLACEMENT

1. Refer to Frames 45 & 46.
2. Refer to Frame 53.
3. Remove the electrical cover at the clips.
4. Carefully disconnect all electrical connectors
5. Remove pcb from mounting posts.
6. Take the new Primary PCB and attach the appropriate Boiler Chip Card (BCC) to it (this should correspond to the output of the boiler: 26kW, 32kW or 40kW).
Note. Ensure the correct orientation of BCC by placing "TOP" side up as shown.
7. Replace in reverse order.
8. Check the operation of the boiler. Refer to Frames 33-36.

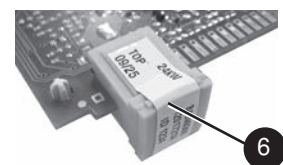
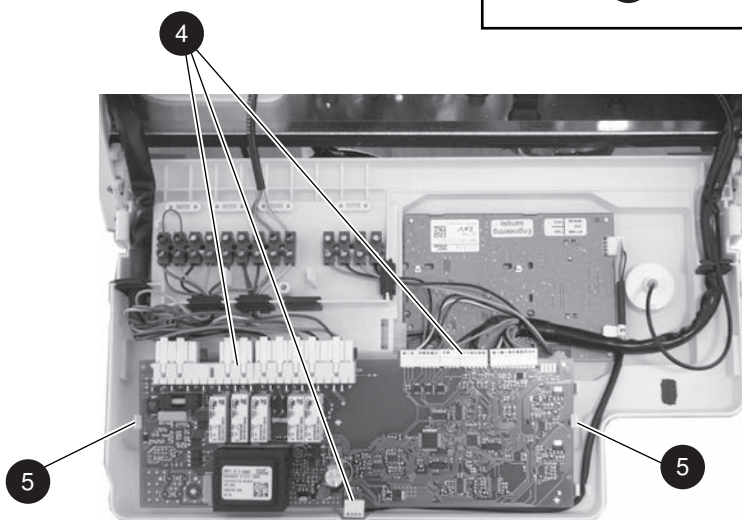
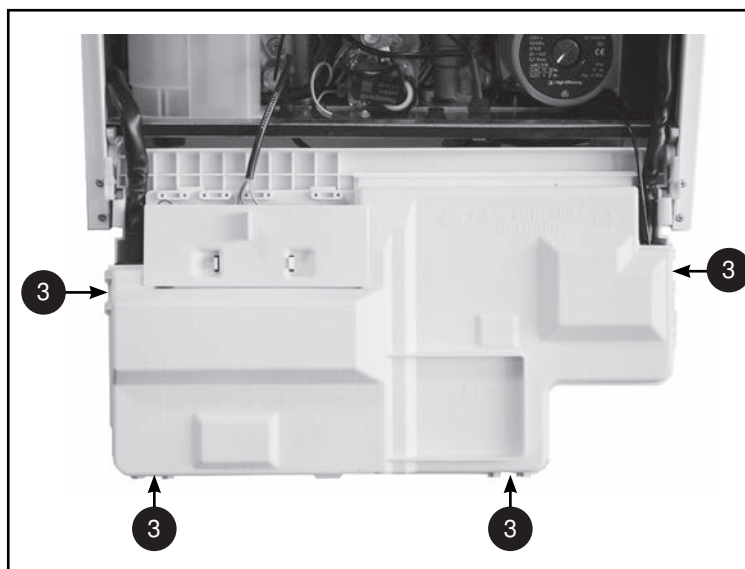

65 USER PCB REPLACEMENT

1. Refer to Frames 45 & 46.
2. Refer to Frame 53.
3. Set both the user temperature selector knobs to the 12 o'clock position.
4. Remove the electrical cover at the clips indicated. Refer to Frame 64.
5. Disconnect all electrical connectors carefully
6. Remove pcb from mounting posts.
7. Replace the pcb in reverse order.
8. Check the operation of the boiler. Refer to Frames 33-36.

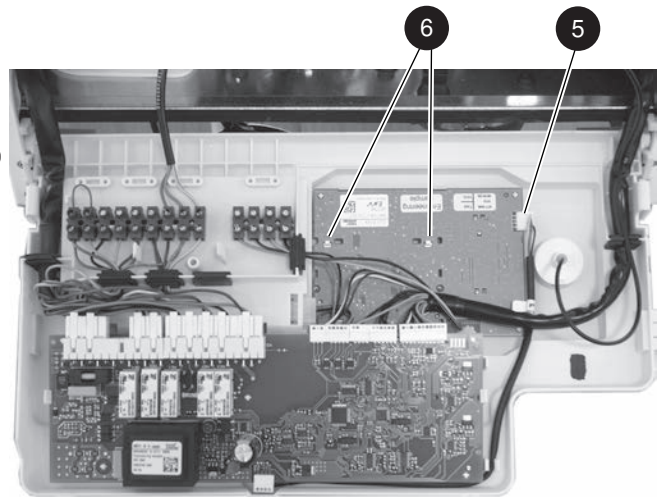

66 DHW FLOW TURBINE SENSOR REPLACEMENT

1. Refer to Frames 45 & 46.
2. Refer to Frame 53.
3. Lift off the flow turbine sensor plastic retaining clip.
4. Unplug the electrical connection and transfer to new turbine sensor.
5. Reassemble in reverse order.
6. Check operation of the boiler. Refer to Frames 33-36.

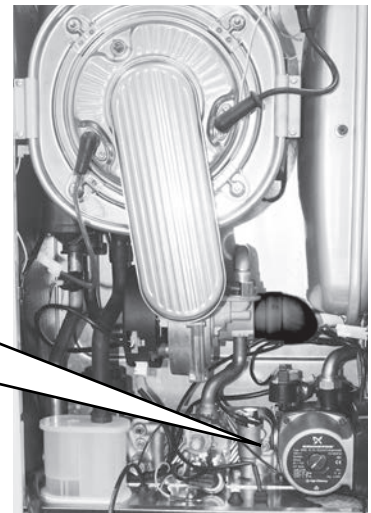
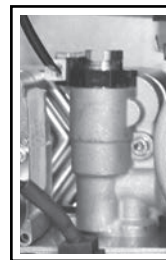

67 DRAINING THE BOILER

CENTRAL HEATING CIRCUIT

1. Close all the CH water isolating valves on the boiler inlet.
2. To drain the primary heat exchanger circuit: Open the drain point by unscrewing using a flat blade screw driver and attach a length of drain hose.
3. After replacing any component on the boiler, remove the hose, close the drain valve and open all system isolating valves (re-pressurise as appropriate by re-connecting the filling loop, refer to Frame 24) before proceeding to check operation of the boiler.
4. Disconnect filling loop. Refer to Frame 24.
5. Check operation of the boiler. Refer to Frames 33-36.

DOMESTIC HOT WATER CIRCUIT

1. Close the DHW water isolating valve on the DHW inlet.
2. To drain the domestic hot water circuit: As there is no direct drain for the domestic hot water circuit, depending on the location of the boiler, opening the lowest hot water tap may drain this circuit. However it must be noted that some residual water will be experienced during replacement of components.
3. After replacing any component on the boiler open the DHW inlet isolating valve and vent the DHW system by opening all hot taps and ensuring water flows from each tap.
4. Disconnect filling loop. Refer to Frame 24.
5. Check operation of the boiler. Refer to Frames 33-36.

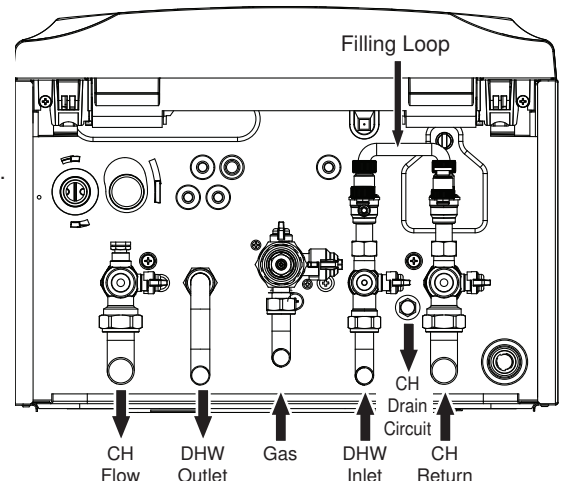

68 PRESSURE GAUGE RENEWAL

1. Refer to Frames 45 & 46.
2. Refer to Frame 53.
3. Close the isolating service valves and drain the (CH) boiler
4. Remove the clip retaining the pressure sensor
5. Remove the sensor.
6. Remove the electrical cover at the clips indicated. Refer to Frame 64.
7. Remove the clip retaining the pressure gauge and remove the gauge, drawing the capillary carefully out of the boiler.
8. Refit in reverse sequence. Refill the CH system. Refer to Frame 67.
9. Check the operation of the boiler. Refer to Frames 33-36.

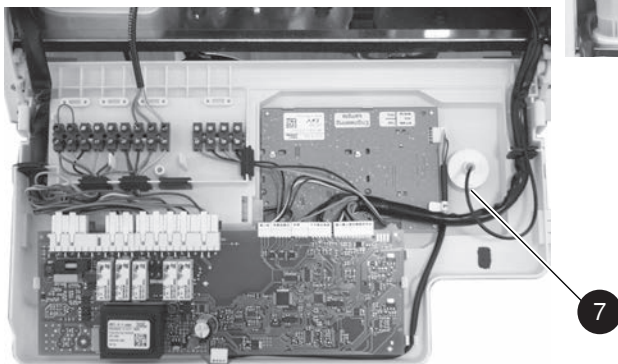
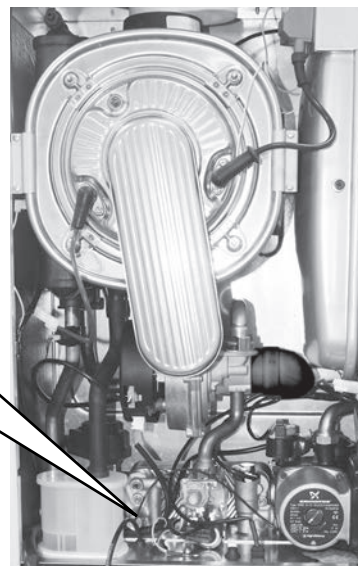
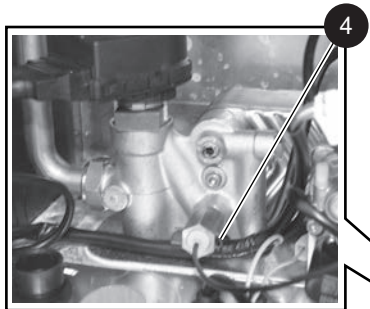

69 PRESSURE RELIEF VALVE RENEWAL

1. Refer to Frames 45 & 46.
2. Refer to Frame 53.
3. Close the isolating service valves and drain the (CH) boiler. Refer to Frame 67.
4. Remove the burner & Fan assembly. Refer to Frame 47.
5. Remove the CH Water Pressure Sensor. Refer to Frame 75
6. Undo the PRV outlet retaining nut. (retaining the washer)
7. Remove the securing clip at the rear of the valve body.
8. Withdraw the valve vertically.
9. Renew the valve and refit in reverse order.
10. Refill the CH system. Refer to Frame 67.
11. Check the operation of the boiler. Refer to Frames 33-36.

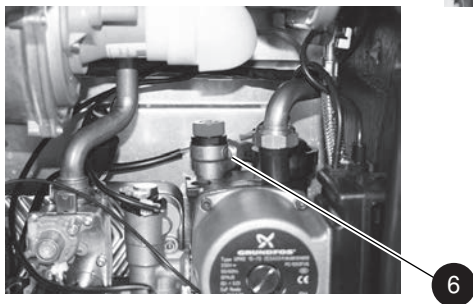
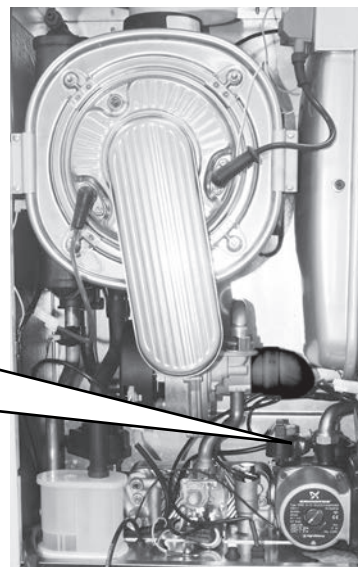
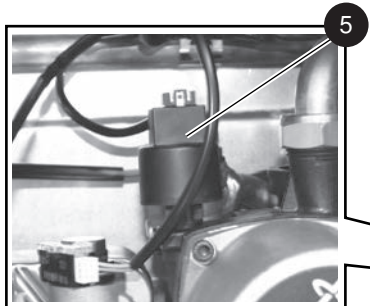

70 PUMP AUTO AIR VENT REPLACEMENT

1. Refer to Frames 45 & 46.
2. Refer to Frame 53.
3. Close the isolating service valves and drain the (CH) boiler. Refer to Frame 67.
4. Remove the burner & Fan assembly. Refer to Frame 47.
5. Remove return pipe connected at top of pump and heat exchanger.
6. The auto air vent is retained in the pump body with a bayonet connection. The air vent and float assembly is removed by turning the head anti-clockwise (viewed from above) and pulling upwards.
7. Reassemble in reverse order.
8. Ensure the air vent head o ring seal is in place when refitting and the seal is in place at the pump outlet connection.
9. Refill the CH system. Refer to Frame 67.
10. Loosen the cap of the air vent.
11. Check the operation of the boiler. Refer to Frames 33-36.

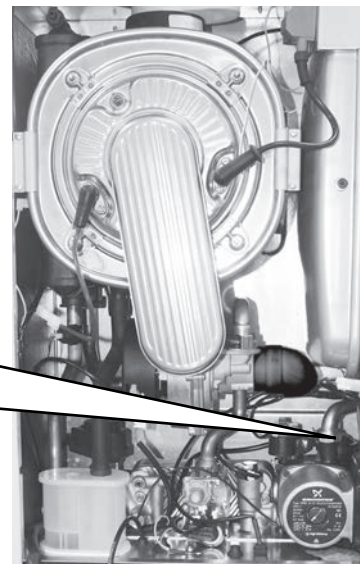
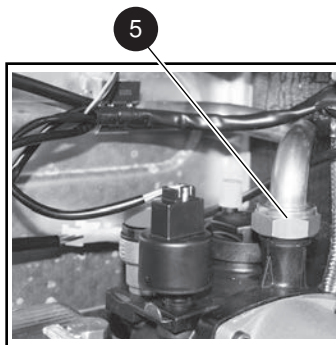

71 DHW FLOW TURBINE SENSOR REPLACEMENT

1. Refer to Frames 45 & 46.
2. Refer to Frame 53.
3. Lift off the flow turbine sensor plastic retaining clip.
4. Unplug the electrical connection and transfer to new turbine sensor.
5. Reassemble in reverse order.
6. Check operation of the boiler. Refer to Frames 33-36.

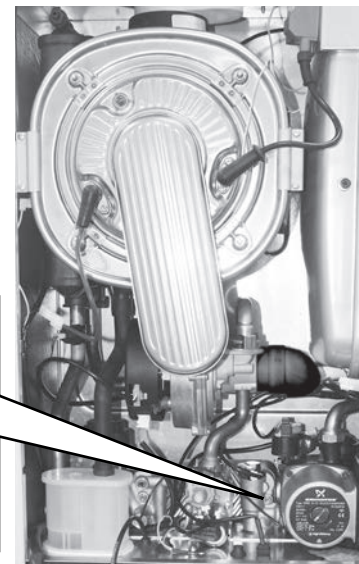
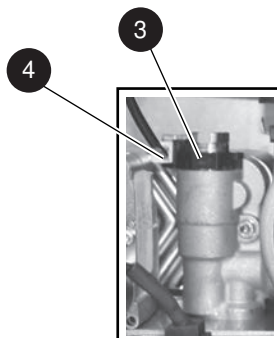

72 DIVERTER VALVE INTERNAL CARTRIDGE REPLACEMENT

1. Refer to Frames 45 & 46.
2. Refer to Frame 53.
3. Close the isolating service valves and drain the (CH) boiler. Refer to Frame 67.
4. Remove the Condense trap. Refer to Frame 50.
5. Disconnect the diverter valve head cable
6. Remove the diverter head retaining clip and withdraw the diverter head.
7. Using a spanner, unscrew the valve assembly from the body and lift out.
8. Reassemble in reverse order.
9. Refill the CH system. Refer to Frame 67.
10. Check the operation of the boiler. Refer to Frames 33-36.

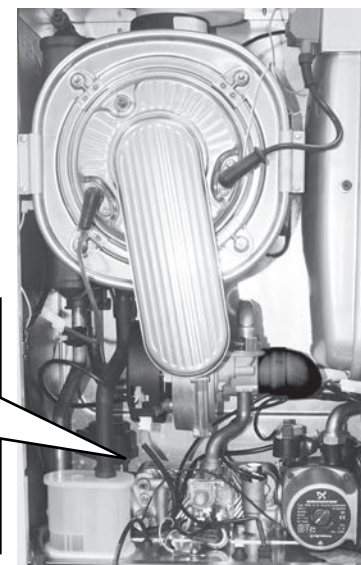
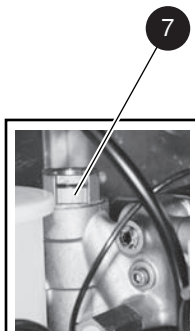

SERVICING

73 DHW PLATE HEAT EXCHANGER REPLACEMENT

1. Refer to Frames 45 & 46.
2. Refer to Frame 53.
3. Close the isolating service valves and drain the heating and DHW systems. Refer to Frame 67.
4. Remove the burner & Fan assembly. Refer to Frame 47.
5. Remove the 2 Allen screws securing the plate heat exchanger to the brass housings.
6. Ease the plate heat exchanger back to disengage and lift out.
7. Fit the new heat exchanger using the new o rings supplied.
8. Refit in reverse order.
9. Open the isolating service valves, refill the CH and DHW systems and vent as necessary. Refer to Frame 67.
10. Check the operation of the boiler. Refer to Frames 33-36.

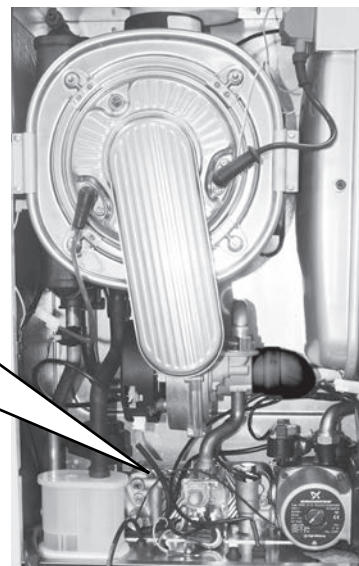
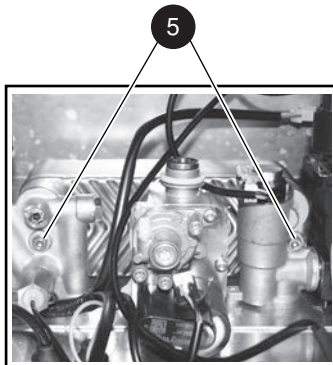

74 PUMP HEAD REPLACEMENT

1. Refer to Frames 45 & 46.
2. Refer to Frame 53.
3. Close the isolating service valves and drain the (CH) boiler. Refer to Frame 67.
4. Disconnect both electrical leads to the pump
5. Remove the 4 Allen screws securing the pump head and remove.
6. Refit in reverse order.
7. Open the isolating valves and refill the CH system. Refer to Frame 67.
8. Check the operation of the boiler. Refer to Frames 33-36.

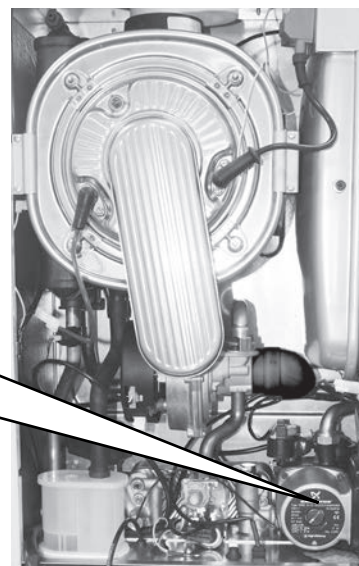
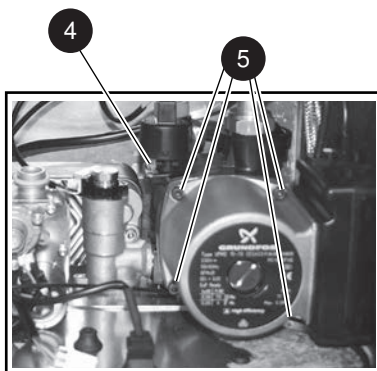

75 CH WATER PRESSURE SENSOR REPLACEMENT

1. Refer to Frames 45 & 46.
2. Refer to Frame 53.
3. Close the isolating service valves and drain the (CH) boiler. Refer to Frame 67.
4. Remove the retaining clip to the rear of the housing.
5. Lift out the sensor and disconnect the electrical connection.
6. Refit in reverse order.
7. Open the isolating valves and refill the CH system. Refer to Frame 67.
8. Check the operation of the boiler. Refer to Frames 33-36.

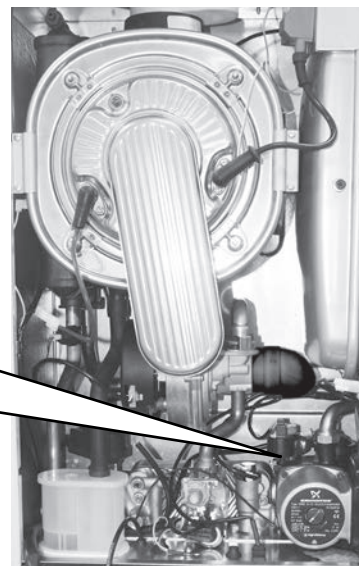
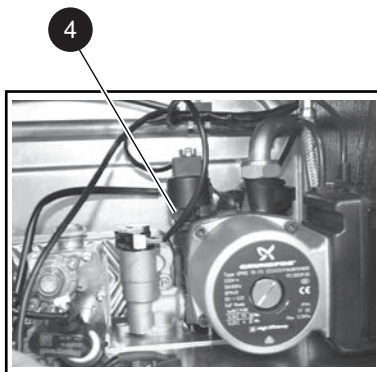

76 DHW FILTER AND FLOW REGULATOR CLEANING/REPLACEMENT

1. Refer to Frames 45 & 46.
2. Refer to Frame 53.
3. Isolate the DHW supply to the boiler.
4. Drain the DHW system. Refer to Frame 67.
5. Remove the DHW Flow Turbine Sensor. See Frame 71.
6. Using a spanner remove the DHW flow turbine cartridge.
7. Unscrew the flow regulator housing.
8. Remove the filter.
9. Clean or replace as necessary.
10. Refit in reverse order.
11. Open the isolating valves and refill DHW system. Refer to Frame 67.
12. Check the operation of the boiler. Refer to Frames 33-36.

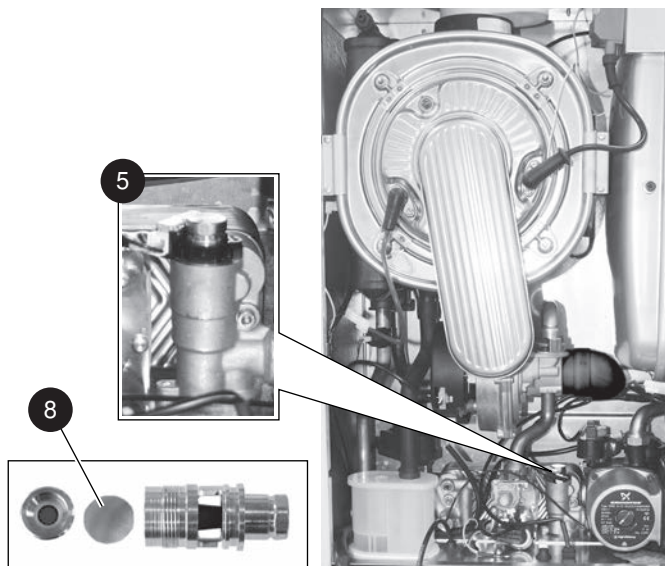

77 FLOW THERMISTOR REPLACEMENT

1. Refer to Frames 45 & 46.
2. Refer to Frame 53.
3. Unclip the flow thermistor.
4. Disconnect the electrical lead from the thermistor.
5. Reconnect the electrical lead to the new thermistor and reassemble in reverse order, ensuring that the thermistor is securely fitted to the pipe on the thermistor locator tabs as shown.
6. Check the operation of the boiler. Refer to Frames 33-36.

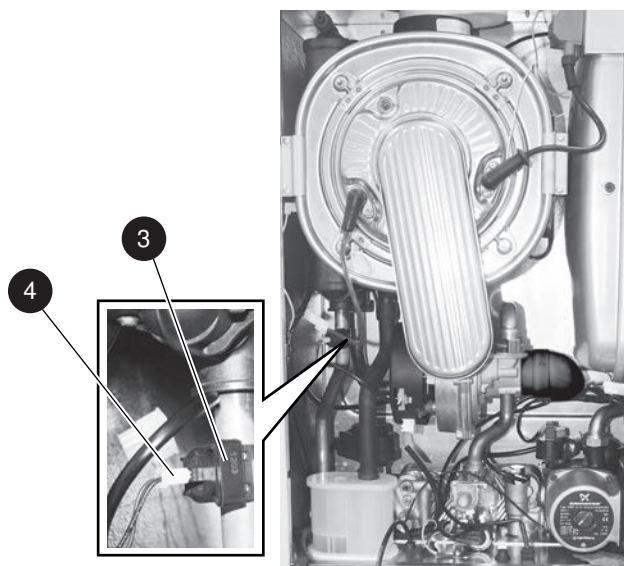

78 HEAT EXCHANGER REPLACEMENT

1. Refer to Frames 45 & 46.
2. Refer to Frame 53.
3. Close the isolating service valves and drain the (CH) boiler. Refer to Frame 67.
4. Remove the Burner & Fan assembly. Refer to Frame 47.
5. Remove the securing clips to disconnect the flow and return pipes below the heat exchanger.
6. Disconnect the condensate pipe from the sump
7. Disconnect the DRYFIRE ONE TIME sensor lead.
8. Remove the horseshoe bracket and lift up the flue turret.
9. Remove the securing screws and disconnect the flue outlet
10. Remove the 4 screws securing the heat exchanger fixing brackets.
11. Remove the heat exchanger forwards, lifting to clear the flow and return pipes
12. Refit in reverse order. Ensure all wires and harnesses are in their correct position in order to prevent damage to them.
13. Open the isolating valves and refill the CH system. Refer to Frame 67.
14. Check the operation of the boiler. Refer to Frames 33-36.

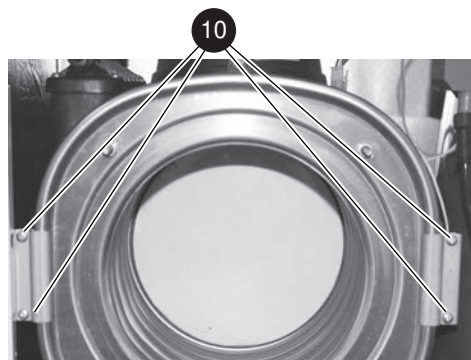
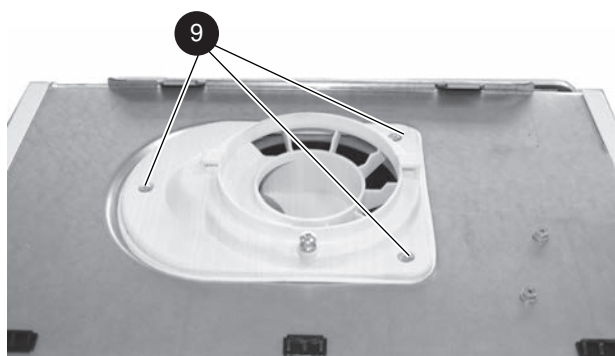
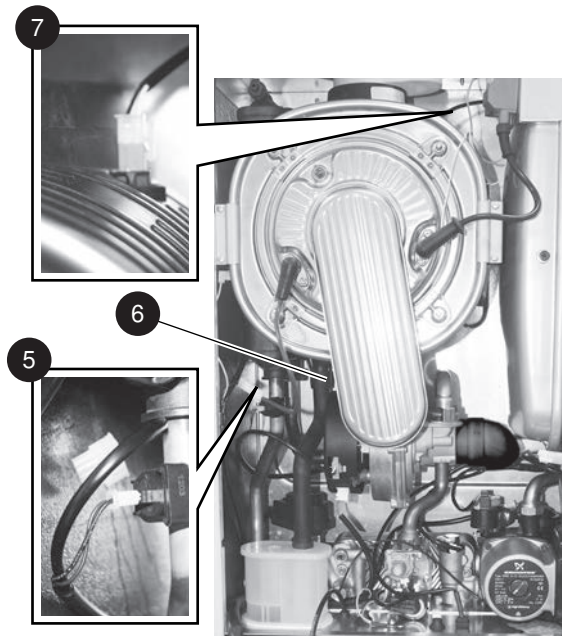

79 EXPANSION VESSEL RECHARGING AND REPLACEMENT

Recharging:

1. Refer to Frames 45 & 46.
2. Refer to Frame 53.
3. Remove the charge point cover.
4. Recharge the tank pressure to 0.75bar
5. Refit in reverse order
6. Check the operation of the boiler. Refer to Frames 33-36.

Replacement:

7. Refer to Frame 45 & 46.
8. Refer to Frame 53.
9. Close the isolating service valves and drain the (CH) boiler
10. Remove the clip securing the flexible connecting hose and disconnect.
11. Remove the two securing screws from the top of the casing at the same time holding the ignitor bracket to prevent movement.
12. Hold the expansion vessel and move the ignition assembly bracket carefully to one side.
13. Pull the bottom of the expansion vessel forward, when free pull vessel downwards and remove.
14. Refit in reverse order.
15. Open the isolating valves and refill the CH system.
16. Check the operation of the boiler. Refer to Frames 33-36.

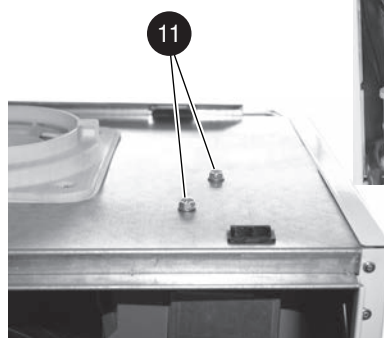
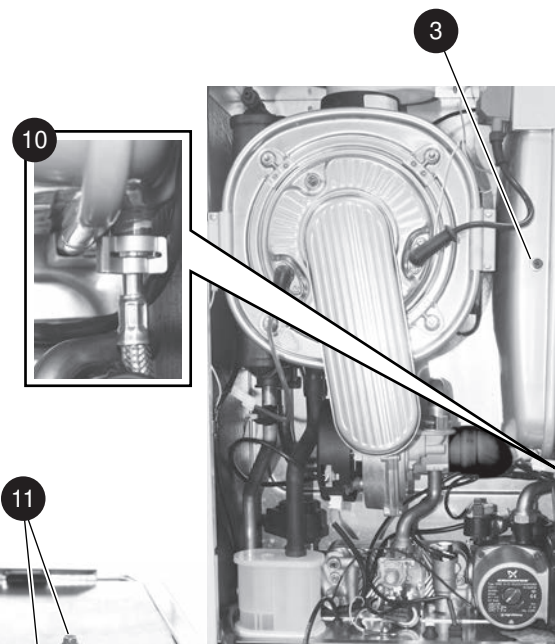

80 BOILER SEALING PANEL REPLACEMENT

1. Refer to Frames 45 & 46.
2. Refer to Frame 53.
3. Remove the old seal from the casing.
4. Fit the new seal ensuring correct location over the fixing pins and the material is fully located within the casing.
5. Reassemble in reverse order.
6. Check the operation of the boiler. Refer to Frames 33-36.

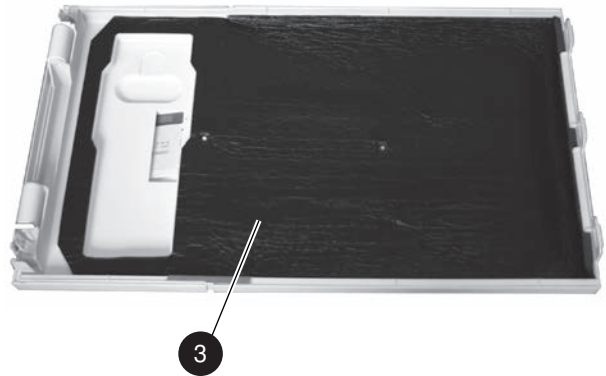

FAULT FINDING

81 FAULT FINDING CHART MAIN MENU

FAULT FINDING CHART MAIN MENU

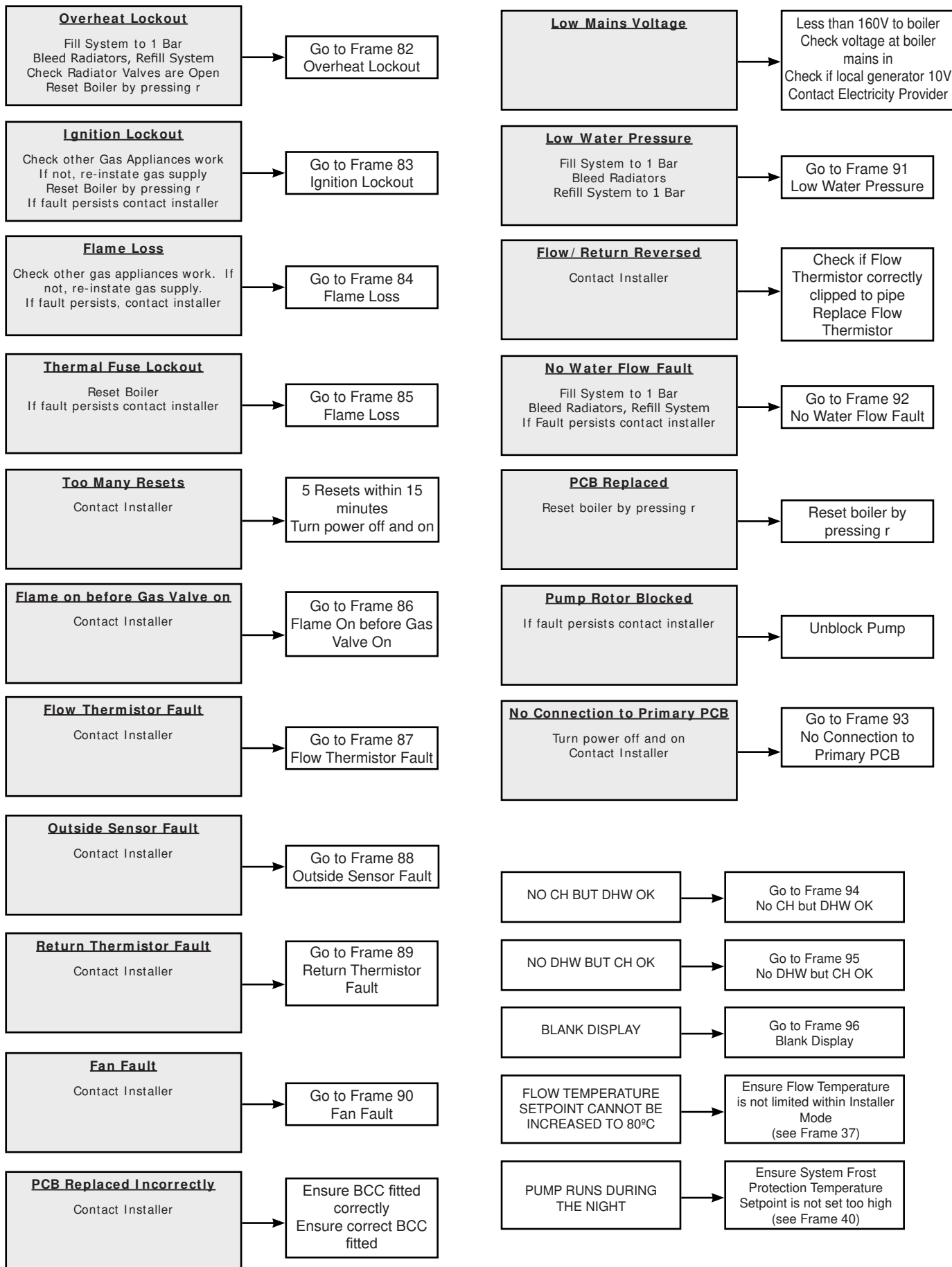

FAULT FINDING

82 OVERHEAT LOCKOUT

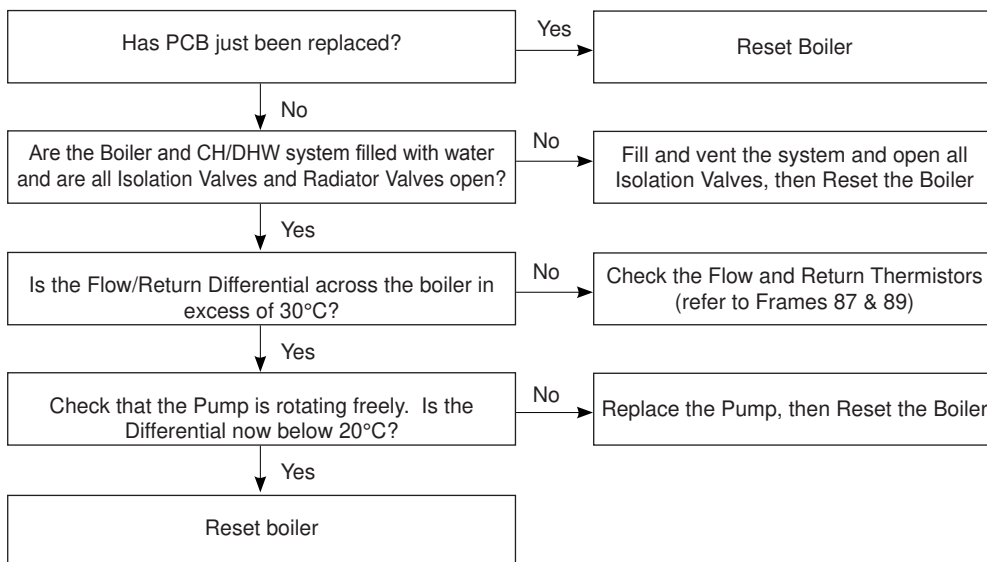

83 IGNITION LOCKOUT

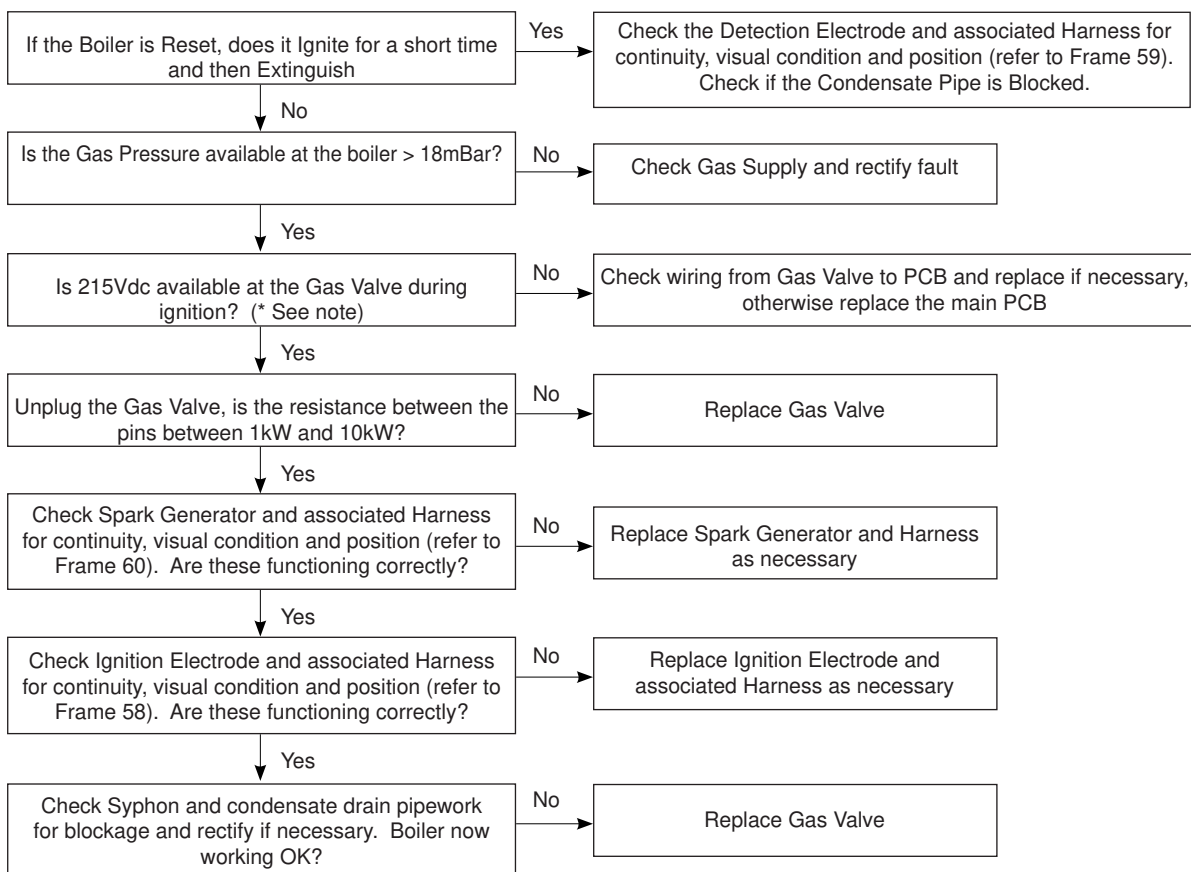

FAULT FINDING

84 FLAME LOSS

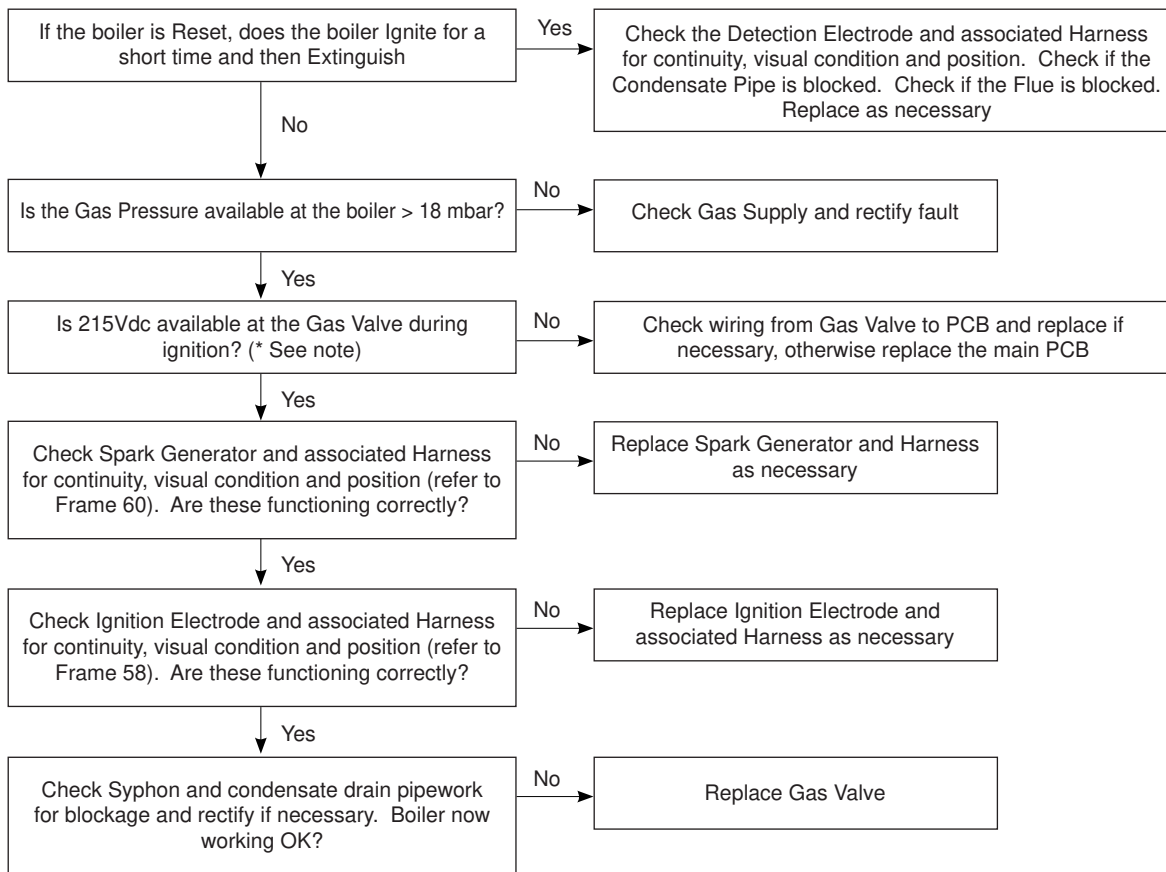

* Note: due to the wave form of the rectified voltage, the reading will vary depending on the type of meter used to measure the value. In general terms a reading of greater than 150V indicates that the correct voltage is supplied to the gas valve

85 THERMAL FUSE LOCKOUT

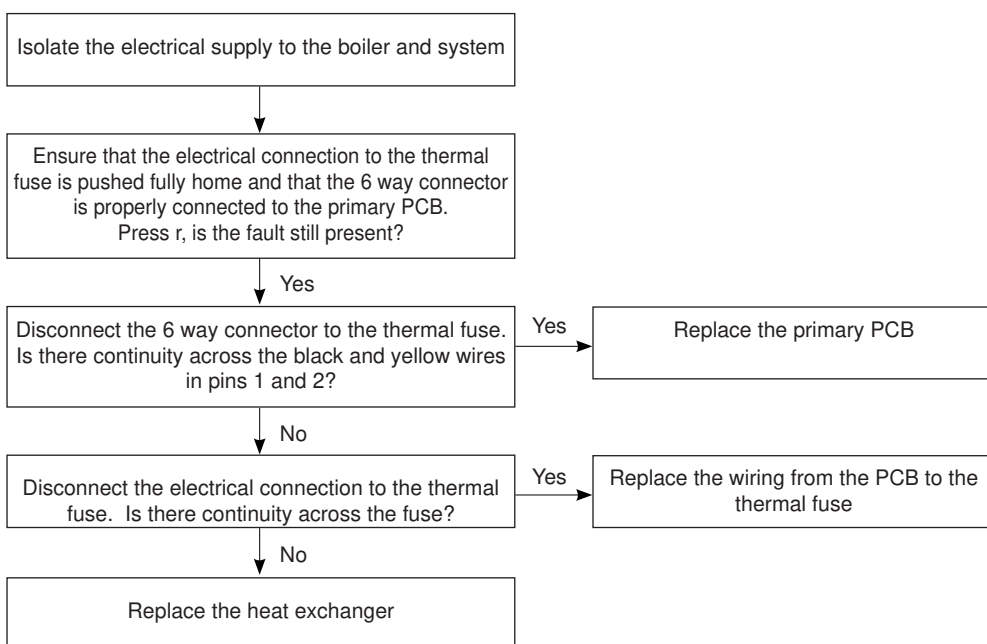

FAULT FINDING

86 FLAME ON BEFORE GAS VALVE ON

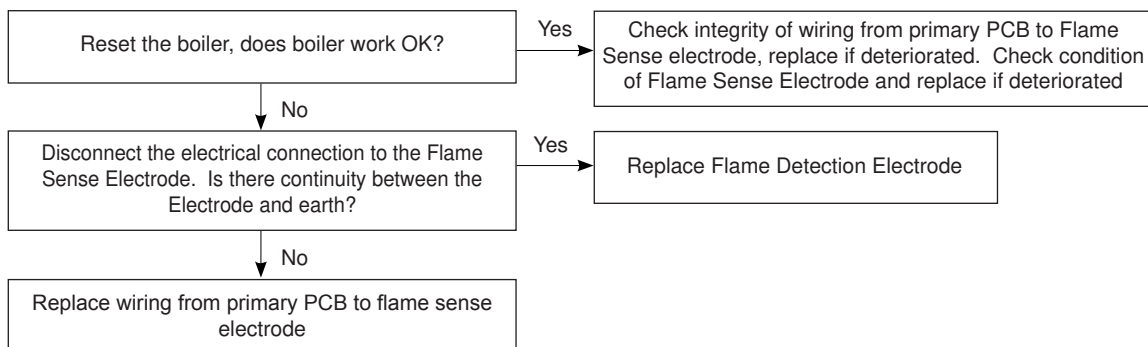

87 FLOW THERMISTOR FAULT

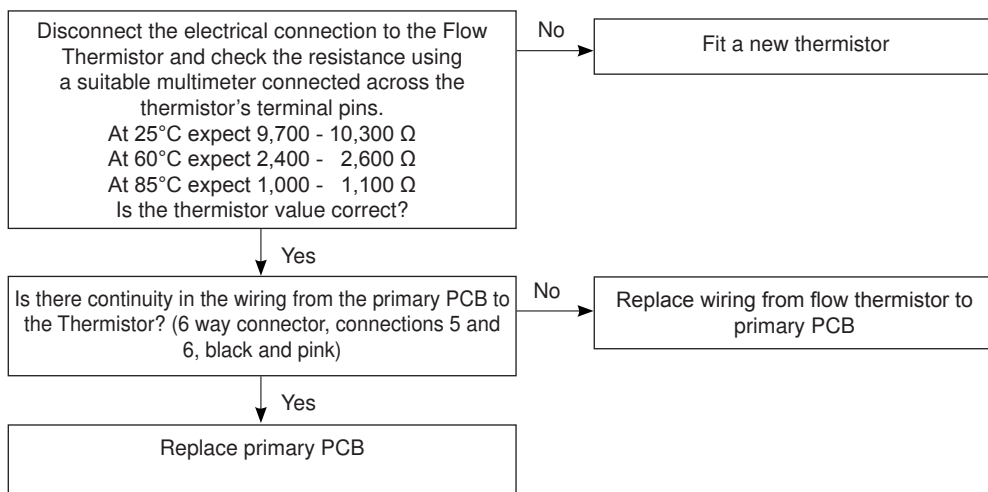

88 OUTSIDE SENSOR FAULT

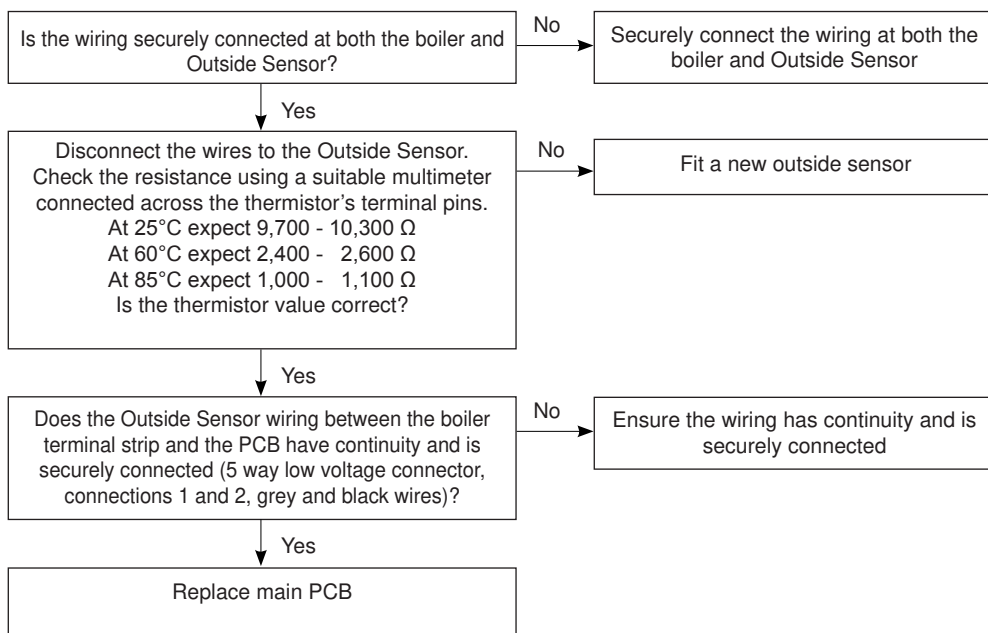

FAULT FINDING

89 RETURN THERMISTOR FAULT

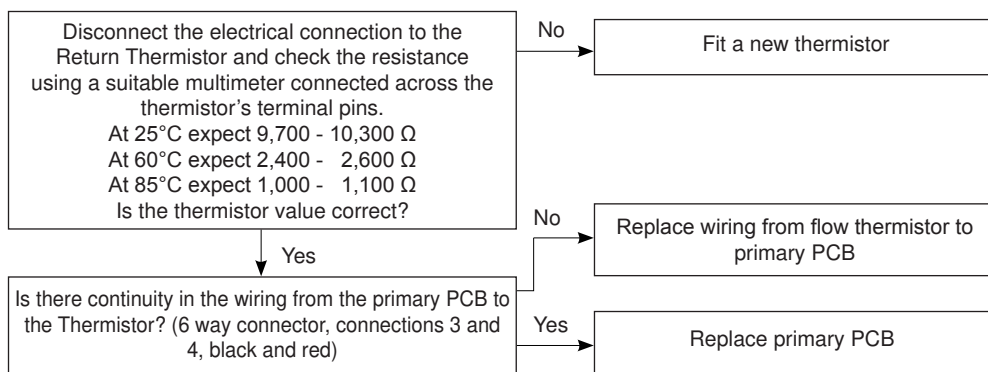

90 FAN FAULT

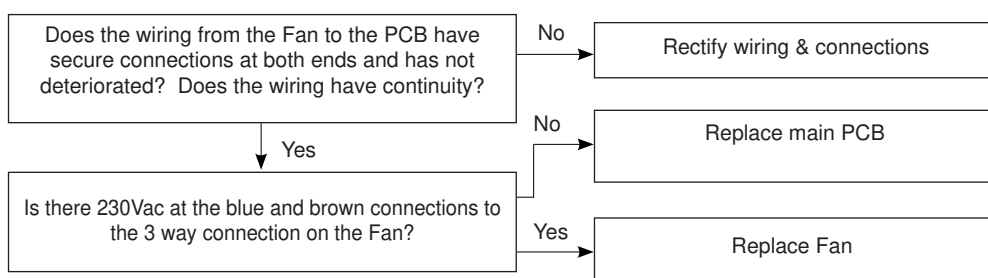

91 LOW WATER PRESSURE

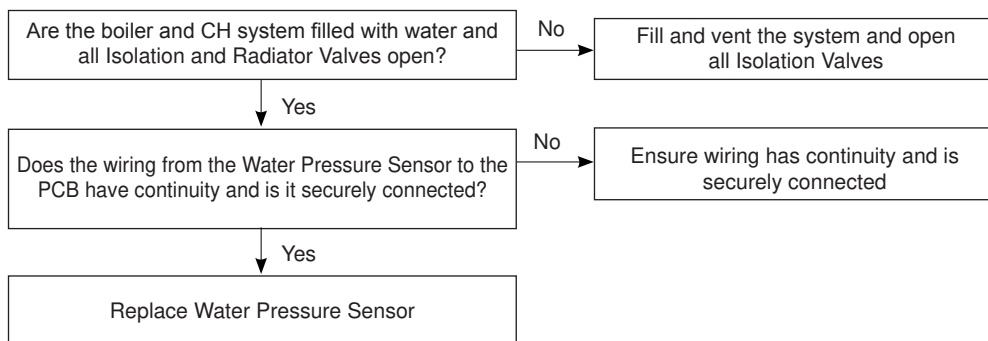

92 NO WATER FLOW

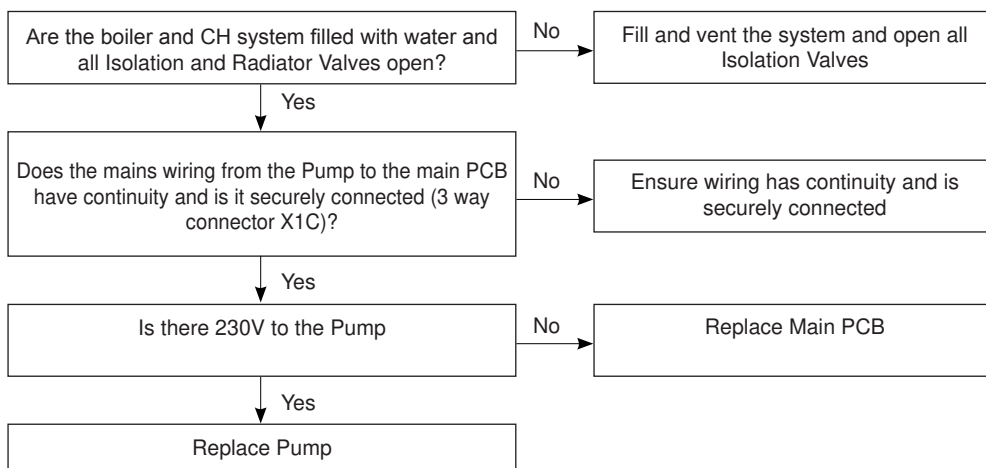

SPARE PARTS

93 NO CONNECTION TO PRIMARY PCB

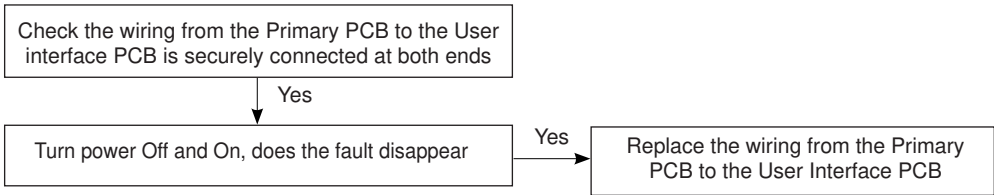

94 NO CH BUT DHW OK

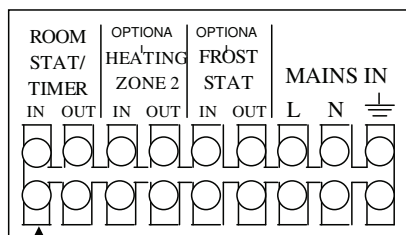
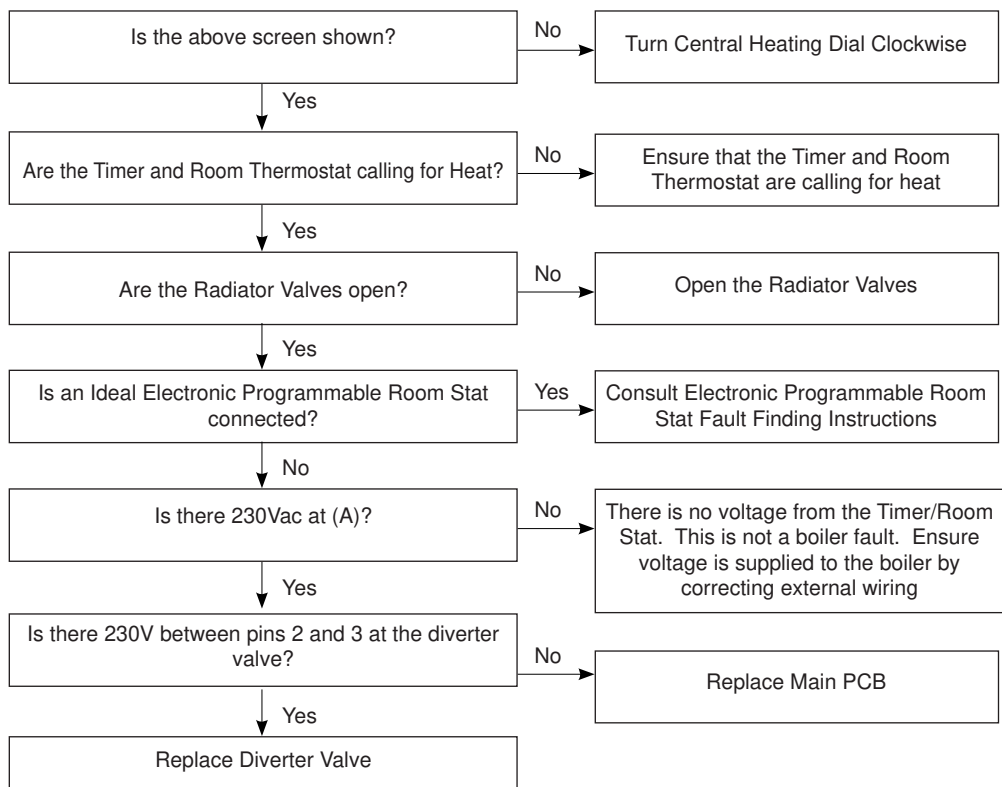
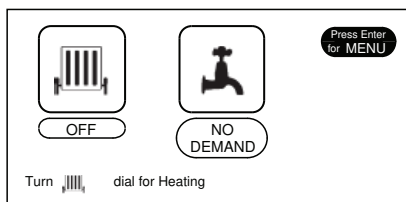

A

FAULT FINDING

95 NO DHW BUT CH OK

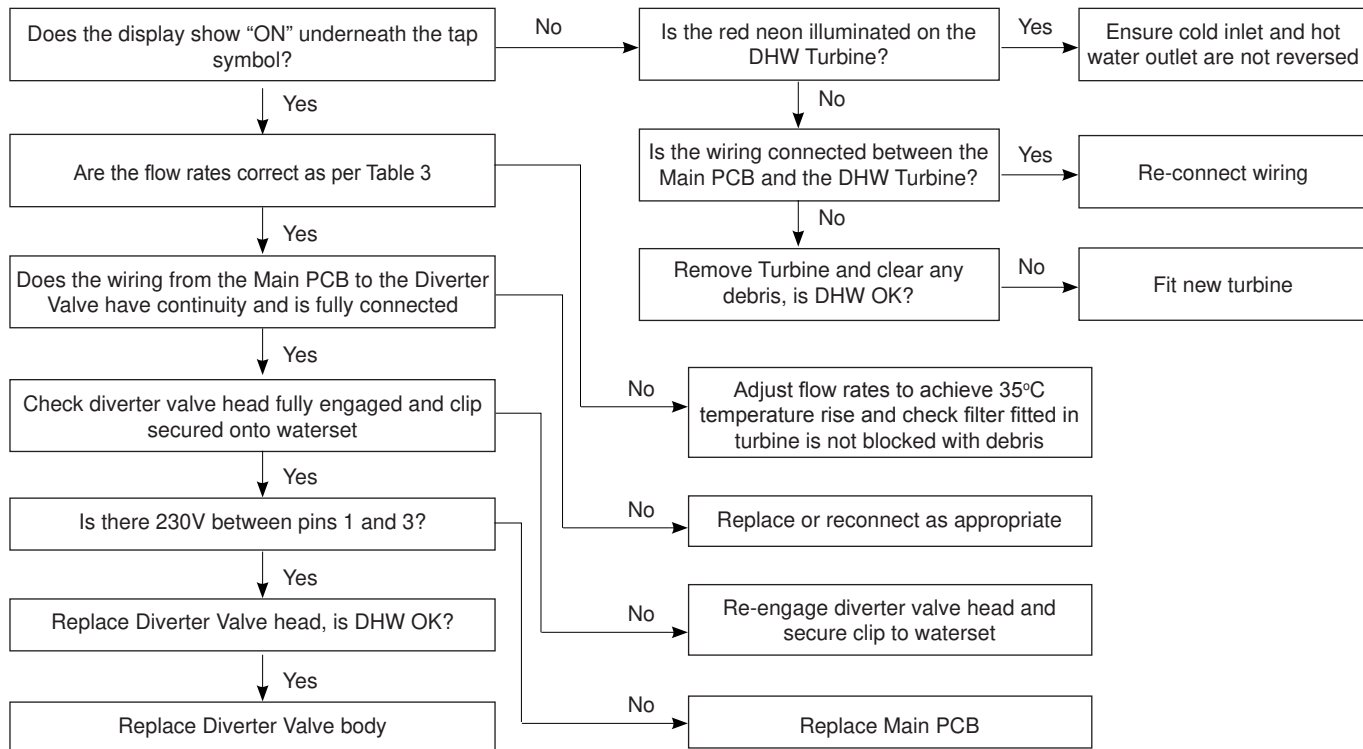

96 BLANK DISPLAY

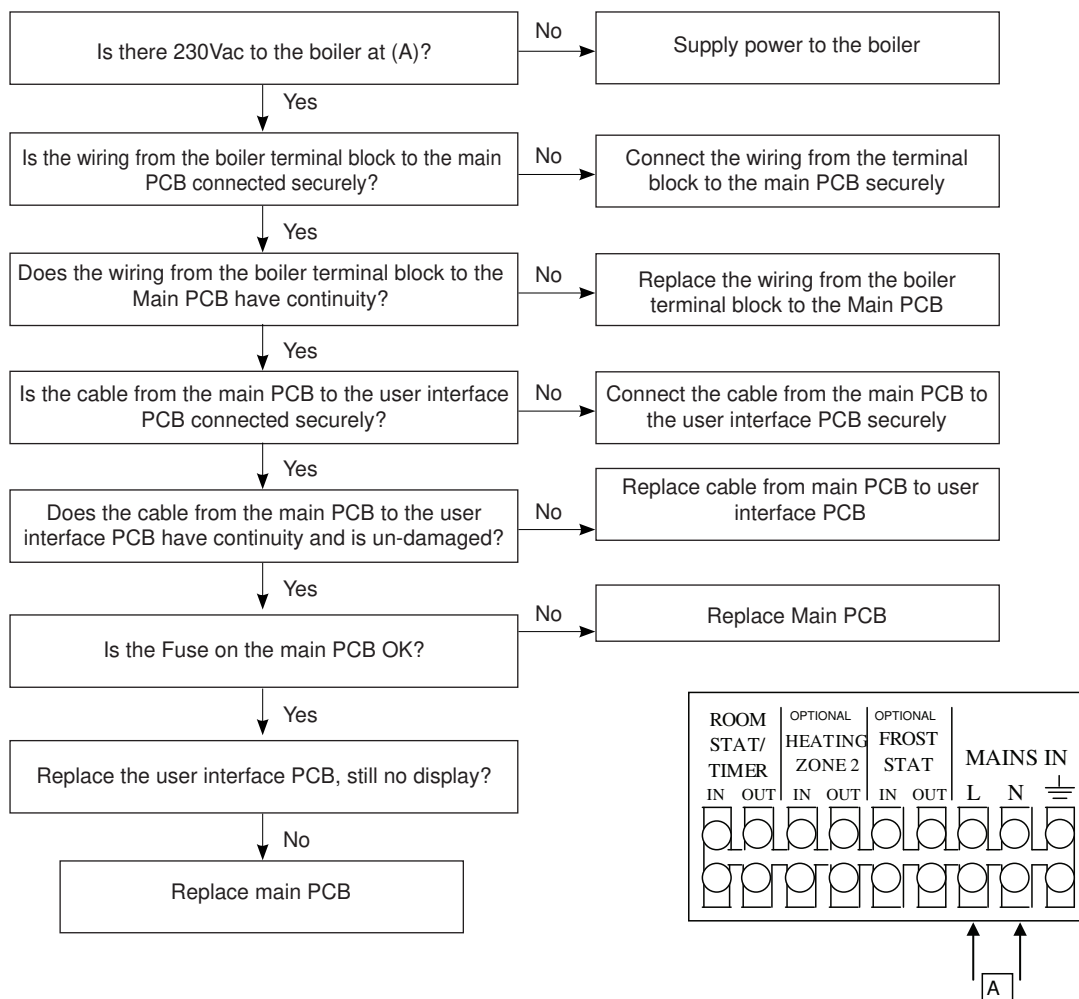

SPARE PARTS

When replacing any part on this appliance use only spare parts that you can be assured conform to the safety and performance specification that we require. Do not use reconditioned or copy parts that have not been clearly authorised by Ideal. Failure to do so could affect safety or performance of this appliance.

Comprehensive spares parts information and details of approved Ideal Parts Distributors are available on www.idealparts.com

Our Parts team are also available to help with your Ideal Spare Parts enquiries on 01482 498665.

When calling, and to ensure we can provide you with the most accurate parts information, please ensure you have the following to hand;

- Boiler Model
- Appliance GC Number
- Boiler Serial Number

Code Of Practice

For the installation, commissioning and servicing of domestic heating and hot water products

Benchmark places responsibilities on both manufacturers and installers.* The purpose is to ensure that customers** are provided with the correct equipment for their needs, that it is installed, commissioned and serviced in accordance with the manufacturer's instructions by competent persons and that it meets the requirements of the appropriate Building Regulations. Installers are required to carry out work in accordance with the following:

Standards of Work

- Be competent and qualified to undertake the work required.
- Install, commission, service and use products in accordance with the manufacturer's instructions provided.
- Ensure that where there is responsibility for design work, the installation is correctly sized and fit for purpose.
- Meet the requirements of the appropriate Building Regulations. Where this involves notifiable work be a member of a Competent Persons Scheme or confirm that the customer has notified Local Authority Building Control (LABC), prior to work commencing.
- Complete all relevant sections of the Benchmark Checklist/Service Record when carrying out commissioning or servicing of a product or system.
- Ensure that the product or system is left in a safe condition and, whenever possible, in good working order.
- Highlight to the customer any remedial or improvement work identified during the course of commissioning or servicing work.
- Refer to the manufacturer's helpline where assistance is needed.
- Report product faults and concerns to the manufacturer in a timely manner.

Customer Service

- Show the customer any identity card that is relevant to the work being carried out prior to commencement or on request.
- Give a full and clear explanation/demonstration of the product or system and its operation to the customer.
- Hand over the manufacturer's instructions, including the Benchmark Checklist, to the customer on completion of an installation.
- Obtain the customer's signature, on the Benchmark Checklist, to confirm satisfactory demonstration and receipt of manufacturer's instructions.
- Advise the customer that regular product servicing is needed, in line with manufacturers' recommendations, to ensure that safety and efficiency is maintained.
- Respond promptly to calls from a customer following completion of work, providing advice and assistance by phone and, if necessary, visiting the customer.
- Rectify any installation problems at no cost to the customer during the installer's guarantee period.



*The use of the word "installer" is not limited to installation itself and covers those carrying out installation, commissioning and/or servicing of heating and hot water products, or the use of supporting products (such as water treatment or test equipment).

**Customer includes householders, landlords and tenants.

NOTES

For additional fault finding advice please visit our website

www.idealboilers.com

Technical Training

The Ideal Technical Training Centre offers a series of first class training courses for domestic, commercial and industrial heating installers, engineers and system specifiers. For details of courses please ring:..... 01482 498 432



The code of practice for the installation, commissioning & servicing of central heating systems



Manufactured under an ISO 9001 registered quality management system

FM 59915

Ideal, P.O. Box 103, National Ave, Kingston upon Hull, HU5 4JN.
Telephone: 01482 492 251 Fax: 01482 448 858. Registration No. London 322 137.

Ideal Stelrad Group pursues a policy of continuing improvement in the design and performance of its products. The right is therefore reserved to vary specification without notice.



Ideal Stelrad Group

Ideal Technical Helpline: 01482 498 663

www.idealboilers.com